

← ⊕ → F

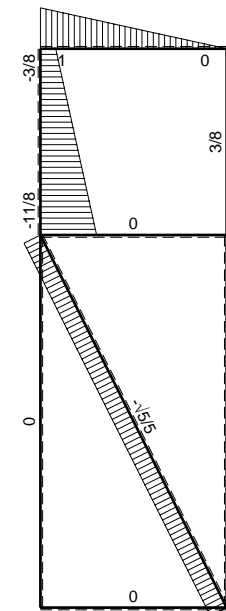

↑ ⊕ ↓ F

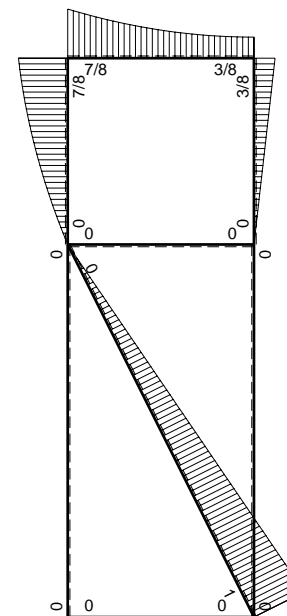

⊕ ⊕ F_b

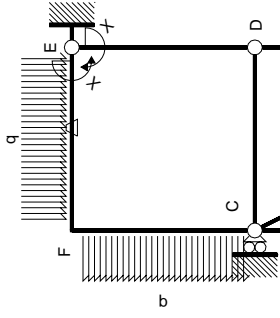

Schema di calcolo iperstatico

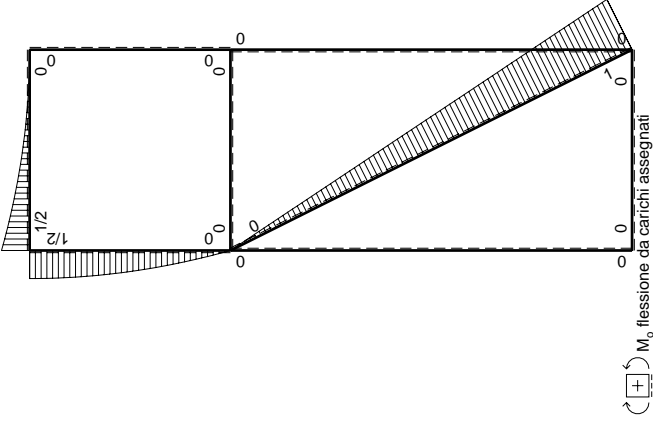

M₀ flessione da carichi assegnati

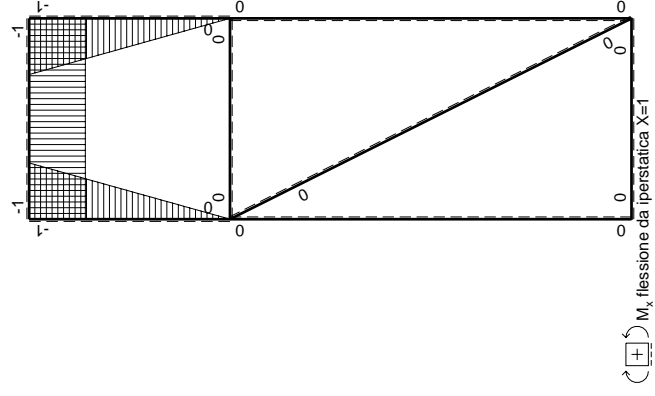

M_x flessione da iperstatica X=1

Quadro contributi PLV per iperstatica X=W ^{EF}		← M _x (x)				M ₀ (x)				θ				M _θ		M _x		∫ M _x (M ₀ /EJ+θ)dx		∫ X M _x M ₀ /EJ dx	
AB	B	0	0	0	0	0	0	0	0	0	0	0	0	0	0	0	0	0	0	0	0
BA	A	0	0	0	0	0	0	0	0	0	0	0	0	0	0	0	0	0	0	0	0
BC	C	0	0	0	0	0	0	0	0	0	0	0	0	0	0	0	0	0	0	0	0
AC	A	0	0	0	0	0	0	0	0	0	0	0	0	0	0	0	0	0	0	0	0
CA	C	0	0	0	0	0	0	0	0	0	0	0	0	0	0	0	0	0	0	0	0
DB	B	0	0	0	0	0	0	0	0	0	0	0	0	0	0	0	0	0	0	0	0
BD	D	0	0	0	0	0	0	0	0	0	0	0	0	0	0	0	0	0	0	0	0
DE	E	-x/b	0	0	0	0	0	0	0	0	0	0	0	0	0	0	0	0	0	0	0
ED	D	1-x/b	0	0	0	0	0	0	0	0	0	0	0	0	0	0	0	0	0	0	0
CD	D	0	0	0	0	0	0	0	0	0	0	0	0	0	0	0	0	0	0	0	0
DC	C	0	0	0	0	0	0	0	0	0	0	0	0	0	0	0	0	0	0	0	0
EF	F	-1	1/2qx ²	-Fb/EJ	-1/2Fx ² /b	Fb/EJ	1	Fb/EJ	1	Fb/EJ	1	Fb/EJ	1	Fb/EJ	1	Fb/EJ	1	Fb/EJ	1	Fb/EJ	1
FE	E	1	-1/2Fb+Fx-1/2qx ²	Fb/EJ	-1/2Fx ² /b	-1/2Fb+Fx-1/2Fx ² /b	1	-1/2Fx ² /b	1	-1/2Fx ² /b	1	-1/2Fx ² /b	1	-1/2Fx ² /b	1	-1/2Fx ² /b	1	-1/2Fx ² /b	1	-1/2Fx ² /b	1
FC	C	-1+x/b	1/2Fb-1/2qx ²	0	-1/2Fb+1/2Fx+1/2Fx ² /b-1/2qx ³ /b	0	0	0	0	0	0	0	0	0	0	0	0	0	0	0	0
CF	F	x/b	-Fx+1/2qx ²	0	-Fx ² /b+1/2qx ³ /b	0	0	0	0	0	0	0	0	0	0	0	0	0	0	0	0
totali																					

Sviluppi di calcolo iperstatica

$$L_{DE}^{xx} = \int_0^b (x^2/b^2) 1/EJ dx = [1/3 x^3/b^2]_0^b 1/EJ$$

$$= (1/3 b) 1/EJ = 1/3 b/EJ$$

$$L_{ED}^{xx} = \int_0^b (1 - 2x/b + x^2/b^2) 1/EJ dx = [x - x^2/b + 1/3 x^3/b^2]_0^b 1/EJ$$

$$= (b - b + 1/3 b) 1/EJ = 1/3 b/EJ$$

$$L_{EF}^{xx} = \int_0^b (1) 1/EJ dx = [x]_0^b 1/EJ$$

$$= (b) 1/EJ = b/EJ$$

$$L_{FE}^{xx} = \int_0^b (1) 1/EJ dx = [x]_0^b 1/EJ$$

$$= (b) 1/EJ = b/EJ$$

$$L_{FC}^{xx} = \int_0^b (1 - 2x/b + x^2/b^2) 1/EJ dx = [x - x^2/b + 1/3 x^3/b^2]_0^b 1/EJ$$

$$= (b - b + 1/3 b) 1/EJ = 1/3 b/EJ$$

$$L_{CF}^{xx} = \int_0^b (x^2/b^2) 1/EJ dx = [1/3 x^3/b^2]_0^b 1/EJ$$

$$= (1/3 b) 1/EJ = 1/3 b/EJ$$

$$L_{EF}^{xo} = \int_0^b (-1/2 x^2/b^2) Fb 1/EJ dx + \int_0^b (1) \theta dx = [-1/6 x^3/b^2]_0^b Fb 1/EJ + [x]_0^b \theta$$

$$= (-1/6 b) Fb 1/EJ + (b) \theta = 5/6 Fb^2/EJ$$

$$L_{FE}^{xo} = \int_0^b (-1/2 + x/b - 1/2 x^2/b^2) Fb 1/EJ dx + \int_0^b (-1) \theta dx$$

$$= [-1/2 x + 1/2 x^2/b - 1/6 x^3/b^2]_0^b Fb 1/EJ + [-x]_0^b \theta$$

$$= (-1/2 b + 1/2 b - 1/6 b) Fb 1/EJ + (-b) \theta = 5/6 Fb^2/EJ$$

$$L_{FC}^{xo} = \int_0^b (-1/2 + 1/2 x/b + 1/2 x^2/b^2 - 1/2 x^3/b^3) Fb 1/EJ dx$$

$$= [-1/2 x + 1/4 x^2/b + 1/6 x^3/b^2 - 1/8 x^4/b^3]_0^b Fb 1/EJ$$

$$= (-1/2 b + 1/4 b + 1/6 b - 1/8 b) Fb 1/EJ = -5/24 Fb^2/EJ$$

$$L_{CF}^{xo} = \int_0^b (-x^2/b^2 + 1/2 x^3/b^3) Fb 1/EJ dx = [-1/3 x^3/b^2 + 1/8 x^4/b^3]_0^b Fb 1/EJ$$

$$= (-1/3 b + 1/8 b) Fb 1/EJ = -5/24 Fb^2/EJ$$

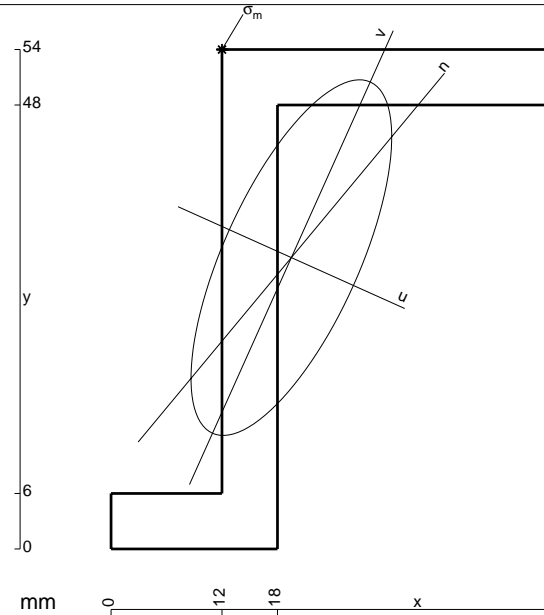

- A = 576. mm²
- J_x = 212976. mm⁴
- J_y = 67824. mm⁴
- J_{xy} = 81648. mm⁴
- J_u = 249641. mm⁴
- J_v = 31159. mm⁴
- α = arctg(2J_{xy}/(J_y-J_x))/2 = -.4221
- c = cos α = .9122
- s = sin α = -.4097
- x_g = 19.5 mm
- y_g = 31.5 mm
- N = -1637. N
- T_y = -818.4 N
- M_x = 750300. Nmm
- x_m = 12. mm
- y_m = 54. mm
- u_m = -16.06 mm
- v_m = 17.45 mm
- σ_m = N/A - Mcv/J_u - Msu/J_v = -209.1 N/mm²

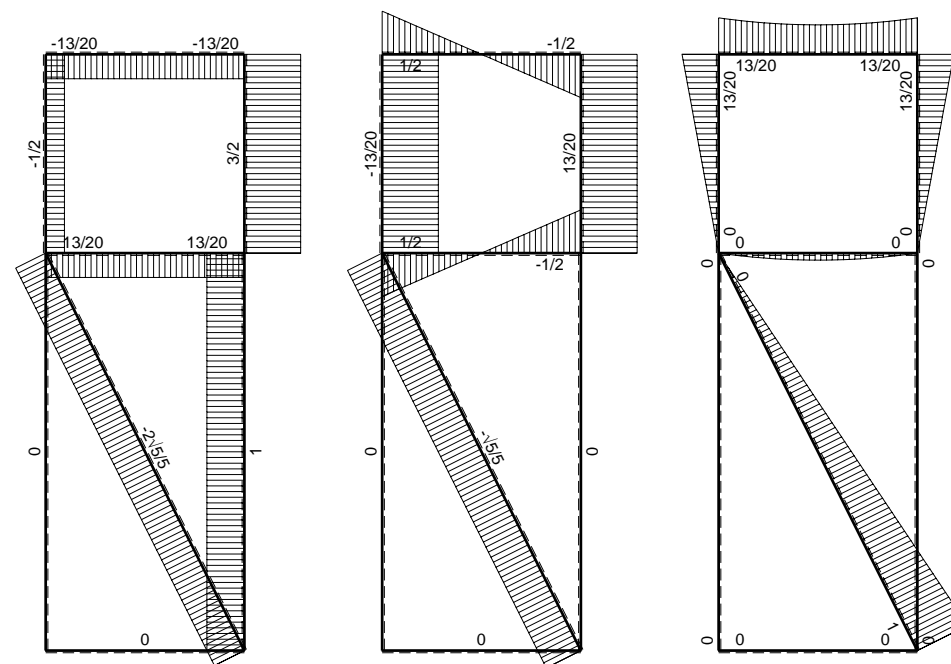
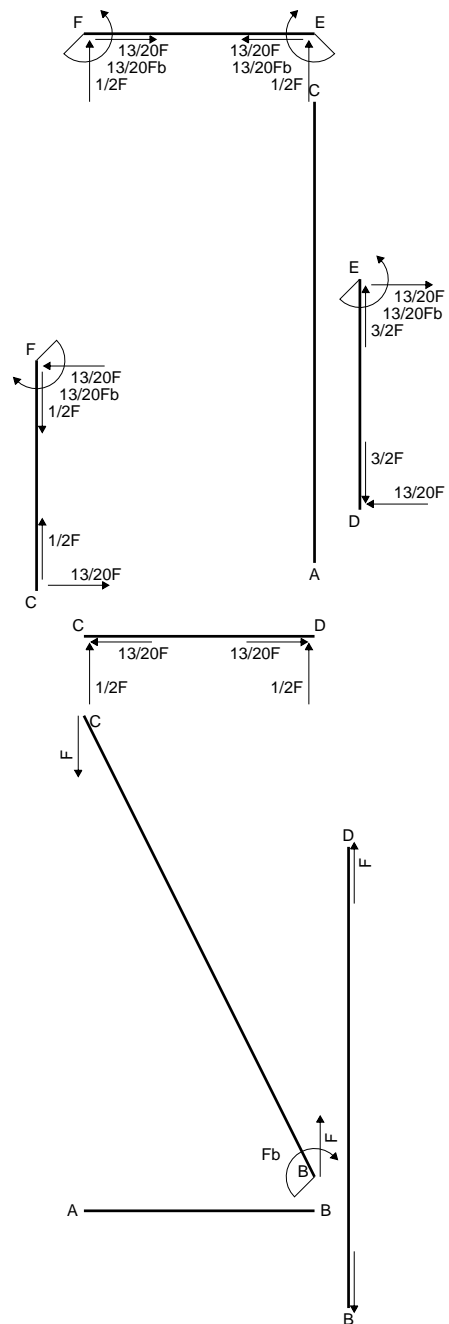

← ⊕ → F

↑ ⊕ ↓ F

⊕ ⊖ F_b

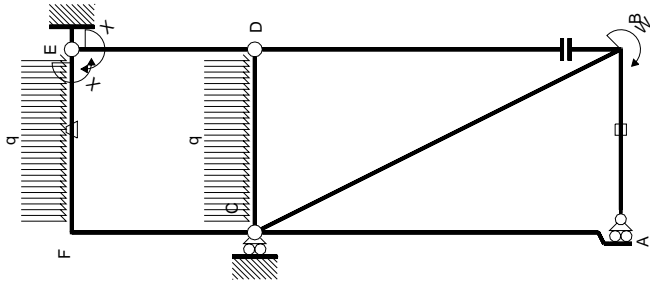

Schema di calcolo iperstatico

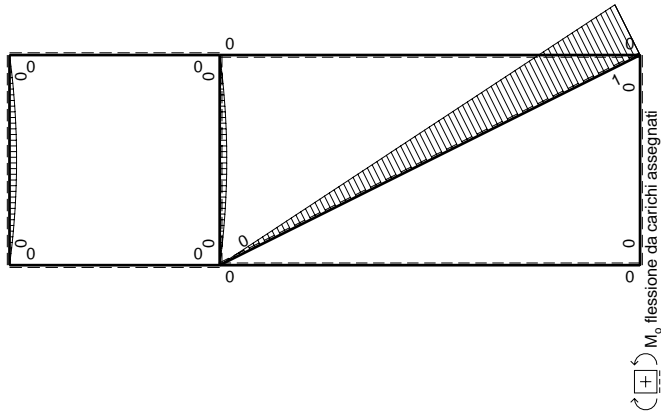

M₀ flessione da carichi assegnati

←	M ^x (x)	M ⁰ (x)	θ	M ^x M ₀	M ^x θ	M ^x M _x	∫M ^x (M ₀ /EJ+θ)dx	∫M ^x M _x /EJdx	Sviluppi di calcolo iperstatica															
							M ^x M _x	M ^x M ₀	M ^x θ	M ⁰ M ₀	M ⁰ θ	M ₀ M _x	M ₀ θ	M _x M _x	M _x M ₀	M _x θ	M ₀ M ₀	M ₀ θ	M _x θ					
AB b	0	0	0	0	0	0	0	0	0	0	0	0	0	0	0	0	0	0	0	0	0	0	0	
BA b	0	0	0	0	0	0	0	0	0	0	0	0	0	0	0	0	0	0	0	0	0	0	0	0
BC √5b	0	Fb-√5/5Fx	0	0	0	0	0	0	0	0	0	0	0	0	0	0	0	0	0	0	0	0	0	0
CA 2b	0	0	0	0	0	0	0	0	0	0	0	0	0	0	0	0	0	0	0	0	0	0	0	0
AC 2b	0	0	0	0	0	0	0	0	0	0	0	0	0	0	0	0	0	0	0	0	0	0	0	0
DB 2b	0	0	0	0	0	0	0	0	0	0	0	0	0	0	0	0	0	0	0	0	0	0	0	0
BD 2b	0	0	0	0	0	0	0	0	0	0	0	0	0	0	0	0	0	0	0	0	0	0	0	0
DE b	-x/b	0	0	0	0	0	0	0	0	0	0	0	0	0	0	0	0	0	0	0	0	0	0	0
ED b	1-x/b	0	0	0	0	0	0	0	0	0	0	0	0	0	0	0	0	0	0	0	0	0	0	0
CD b	0	1/2Fx-1/2qx ²	0	0	0	0	0	0	0	0	0	0	0	0	0	0	0	0	0	0	0	0	0	0
DC b	0	-1/2Fx+1/2qx ²	0	0	0	0	0	0	0	0	0	0	0	0	0	0	0	0	0	0	0	0	0	0
FE b	-1	-1/2Fx+1/2qx ²	-Fb/EJ	1/2Fx-1/2Fx ² /b	Fb/EJ	1	(1/12+1)Fb ² /EJ	Xb/EJ	0	0	0	0	0	0	0	0	0	0	0	0	0	0	0	0
FB b	1	1/2Fx-1/2qx ²	Fb/EJ	1/2Fx-1/2Fx ² /b	Fb/EJ	1	(1/12+1)Fb ² /EJ	Xb/EJ	0	0	0	0	0	0	0	0	0	0	0	0	0	0	0	0
FC b	-1+x/b	0	0	0	0	0	0	0	0	0	0	0	0	0	0	0	0	0	0	0	0	0	0	0
CF b	x/b	0	0	0	0	0	0	0	0	0	0	0	0	0	0	0	0	0	0	0	0	0	0	0
totali								0	0	0	0	0	0	0	0	0	0	0	0	0	0	0	0	0
								13/12Fb ² /EJ	5/3Xb/EJ	iperstatica X=W _{EF}														
								-13/20Fb																

Sviluppi di calcolo iperstatica

$$L_{DE}^{xx} = \int_0^b (x^2/b^2) 1/EJ dx = [1/3 x^3/b^2]_0^b 1/EJ$$

$$= (1/3 b) 1/EJ = 1/3 b/EJ$$

$$L_{ED}^{xx} = \int_0^b (1 - 2x/b + x^2/b^2) 1/EJ dx = [x - x^2/b + 1/3 x^3/b^2]_0^b 1/EJ$$

$$= (b - b + 1/3 b) 1/EJ = 1/3 b/EJ$$

$$L_{EF}^{xx} = \int_0^b (1) 1/EJ dx = [x]_0^b 1/EJ$$

$$= (b) 1/EJ = b/EJ$$

$$L_{FE}^{xx} = \int_0^b (1) 1/EJ dx = [x]_0^b 1/EJ$$

$$= (b) 1/EJ = b/EJ$$

$$L_{FC}^{xx} = \int_0^b (1 - 2x/b + x^2/b^2) 1/EJ dx = [x - x^2/b + 1/3 x^3/b^2]_0^b 1/EJ$$

$$= (b - b + 1/3 b) 1/EJ = 1/3 b/EJ$$

$$L_{CF}^{xx} = \int_0^b (x^2/b^2) 1/EJ dx = [1/3 x^3/b^2]_0^b 1/EJ$$

$$= (1/3 b) 1/EJ = 1/3 b/EJ$$

$$L_{EF}^{x\theta} = \int_0^b (1/2 x/b - 1/2 x^2/b^2) Fb 1/EJ dx + \int_0^b (1) \theta dx = [1/4 x^2/b - 1/6 x^3/b^2]_0^b Fb 1/EJ + [x]_0^b \theta$$

$$= (1/4 b - 1/6 b) Fb 1/EJ + (b) \theta = 13/12 Fb^2/EJ$$

$$L_{FE}^{x\theta} = \int_0^b (1/2 x/b - 1/2 x^2/b^2) Fb 1/EJ dx + \int_0^b (-1) \theta dx = [1/4 x^2/b - 1/6 x^3/b^2]_0^b Fb 1/EJ + [-x]_0^b \theta$$

$$= (1/4 b - 1/6 b) Fb 1/EJ + (-b) \theta = 13/12 Fb^2/EJ$$

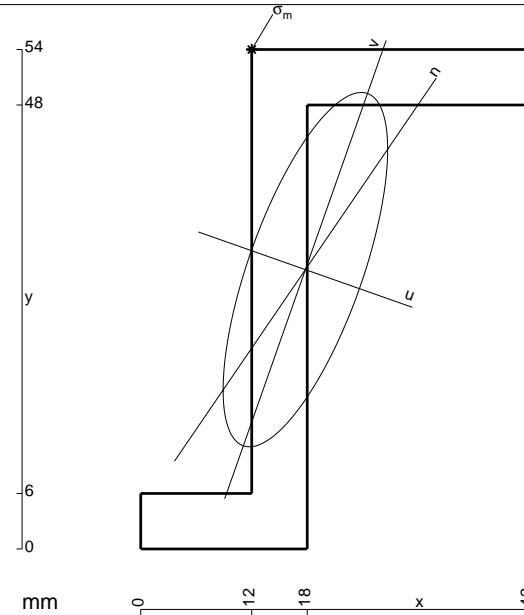

- A = 540. mm²
- J_x = 198266. mm⁴
- J_y = 42746. mm⁴
- J_{xy} = 62554. mm⁴
- J_u = 220304. mm⁴
- J_v = 20709. mm⁴
- α = arctg(2J_{xy}/(J_y-J_x))/2 = -.3387
- c = cos α = .9432
- s = sin α = -.3323
- x_g = 17.8 mm
- y_g = 30.2 mm
- N = -1422. N
- T_y = -711.1 N
- M_x = 715500. Nmm
- x_m = 12. mm
- y_m = 54. mm
- u_m = -13.38 mm
- v_m = 20.52 mm
- σ_m = N/A - Mc_v/J_u - Ms_u/J_v = -219.1 N/mm²

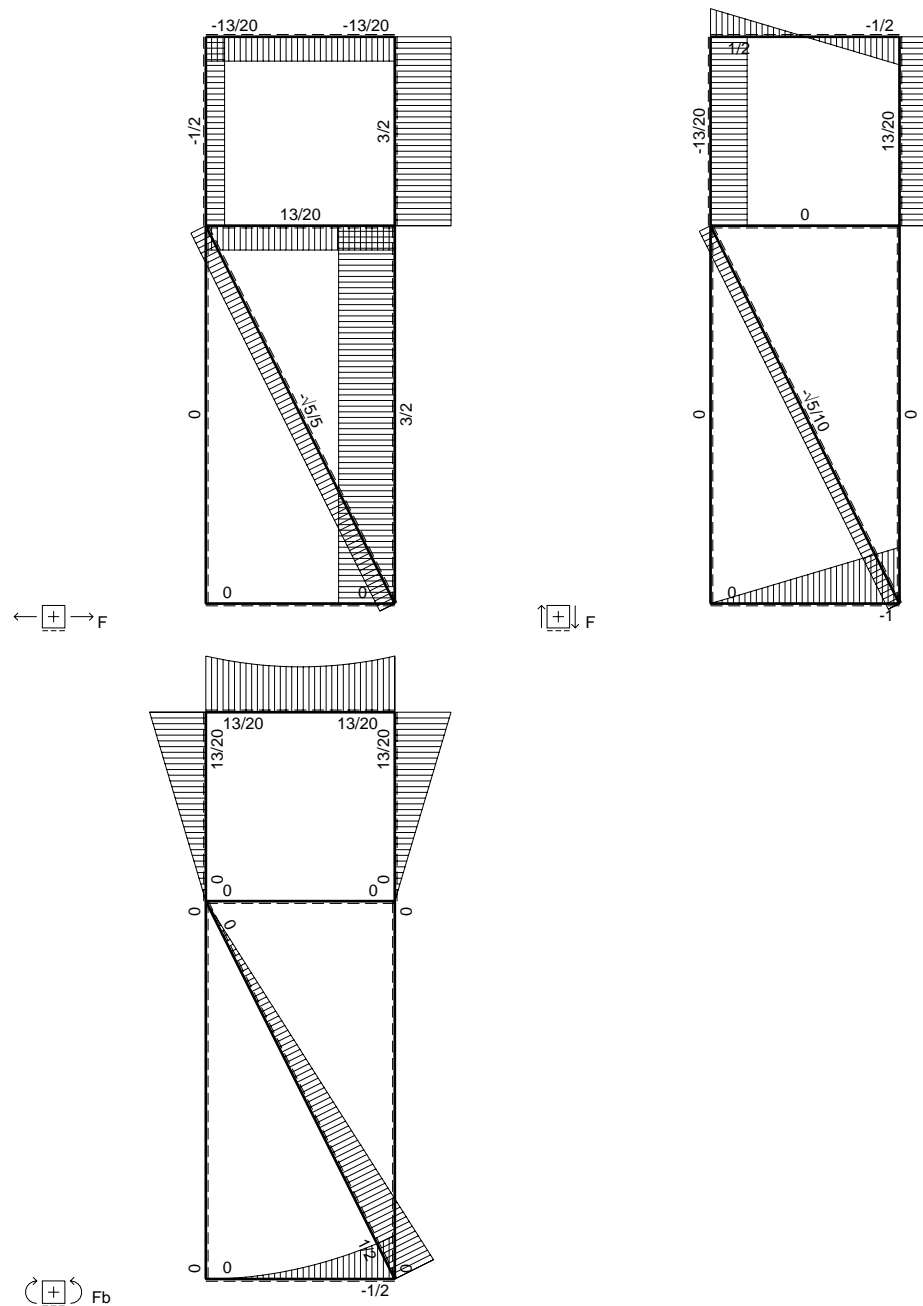
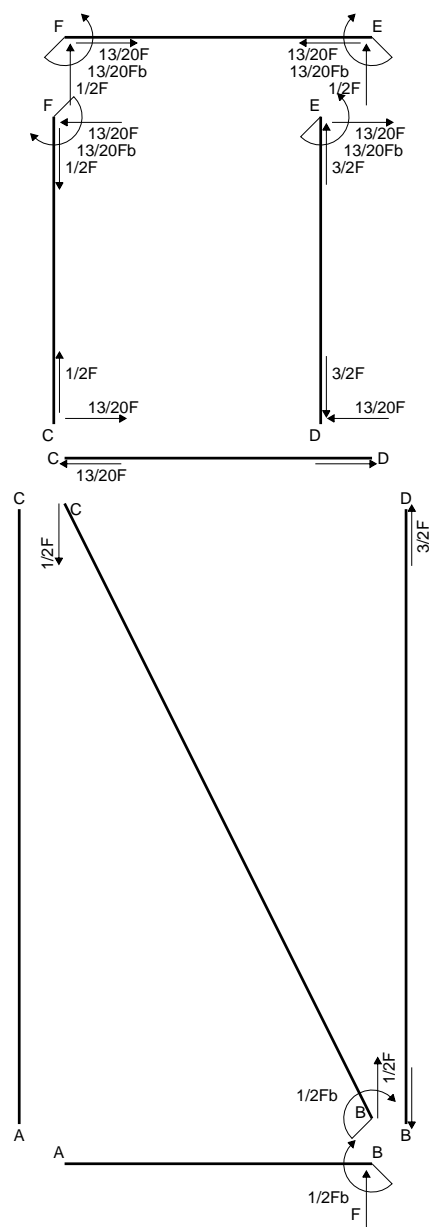

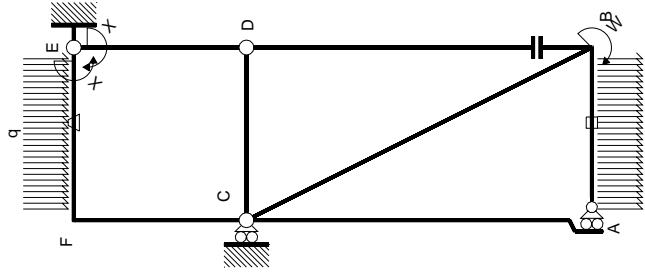

Schema di calcolo iperstatico

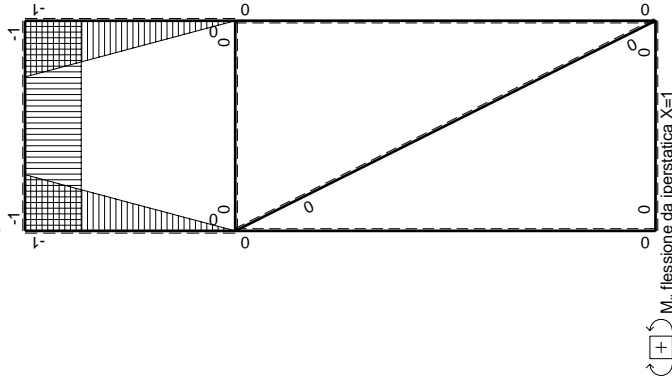

M_x , flessione da iperstatica X=1

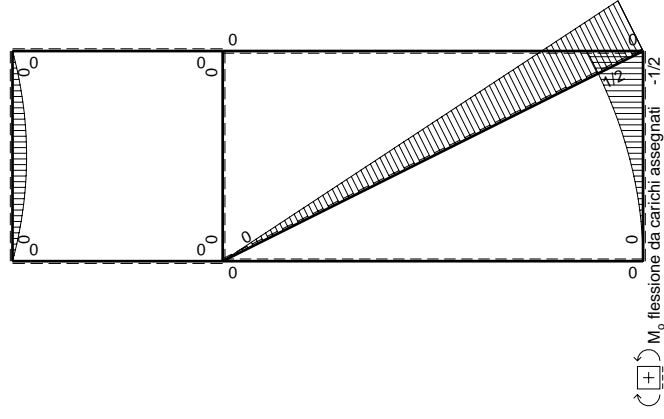

M_0 , flessione da carichi assegnati -1/2

Quadro contributi PLV per iperstatica X=W_{EF}

←	$M_x(x)$	$M_0(x)$	θ	$M_x M_0$	$M_x \theta$	$M_x M_x$	$\int M_x(M_0/EJ+\theta)dx$	$\int M_x M_x/EJ dx$
AB b	0	-1/2qx ²	0	0	0	0	0+0	0
BA b	0	1/2Fb-Fx+1/2qx ²	0	0	0	0	0	0
BC √5b	0	1/2Fb-√5/10Fx	0	0	0	0	0	0
AC 2b	0	0	0	0	0	0	0+0	0
CA 2b	0	0	0	0	0	0	0	0
DB 2b	0	0	0	0	0	0	0+0	0
BD 2b	0	0	0	0	0	0	0	0
DE b	-x/b	0	0	0	0	0	0+0	1/3Xb/EJ
ED b	1-x/b	0	0	0	0	0	0	1/3Xb/EJ
CD b	0	0	0	0	0	0	0	0
DC b	0	0	0	0	0	0	0+0	0
EF b	-1	-1/2Fx+1/2qx ²	-Fb/EJ	1/2Fx-1/2Fx ² /b	Fb/EJ	1	(1/12+1)Fb ² /EJ	Xb/EJ
FE b	1	1/2Fx-1/2qx ²	Fb/EJ	1/2Fx-1/2Fx ² /b	Fb/EJ	1	(1/12+1)Fb ² /EJ	Xb/EJ
FC b	-1+x/b	0	0	0	0	0	0	1/3Xb/EJ
CF b	x/b	0	0	0	0	0	0	1/3Xb/EJ
totali							13/12Fb ² /EJ	5/3Xb/EJ
							-13/20Fb	

Sviluppi di calcolo iperstatica

$$L_{DE}^{xx} = \int_0^b (x^2/b^2) 1/EJ dx = [1/3 x^3/b^2]_0^b 1/EJ$$

$$= (1/3 b) 1/EJ = 1/3 b/EJ$$

$$L_{ED}^{xx} = \int_0^b (1 - 2x/b + x^2/b^2) 1/EJ dx = [x - x^2/b + 1/3 x^3/b^2]_0^b 1/EJ$$

$$= (b - b + 1/3 b) 1/EJ = 1/3 b/EJ$$

$$L_{EF}^{xx} = \int_0^b (1) 1/EJ dx = [x]_0^b 1/EJ$$

$$= (b) 1/EJ = b/EJ$$

$$L_{FE}^{xx} = \int_0^b (1) 1/EJ dx = [x]_0^b 1/EJ$$

$$= (b) 1/EJ = b/EJ$$

$$L_{FC}^{xx} = \int_0^b (1 - 2x/b + x^2/b^2) 1/EJ dx = [x - x^2/b + 1/3 x^3/b^2]_0^b 1/EJ$$

$$= (b - b + 1/3 b) 1/EJ = 1/3 b/EJ$$

$$L_{CF}^{xx} = \int_0^b (x^2/b^2) 1/EJ dx = [1/3 x^3/b^2]_0^b 1/EJ$$

$$= (1/3 b) 1/EJ = 1/3 b/EJ$$

$$L_{EF}^{xo} = \int_0^b (1/2 x/b - 1/2 x^2/b^2) Fb 1/EJ dx + \int_0^b (1) \theta dx = [1/4 x^2/b - 1/6 x^3/b^2]_0^b Fb 1/EJ + [x]_0^b \theta$$

$$= (1/4 b - 1/6 b) Fb 1/EJ + (b) \theta = 13/12 Fb^2/EJ$$

$$L_{FE}^{xo} = \int_0^b (1/2 x/b - 1/2 x^2/b^2) Fb 1/EJ dx + \int_0^b (-1) \theta dx = [1/4 x^2/b - 1/6 x^3/b^2]_0^b Fb 1/EJ + [-x]_0^b \theta$$

$$= (1/4 b - 1/6 b) Fb 1/EJ + (-b) \theta = 13/12 Fb^2/EJ$$

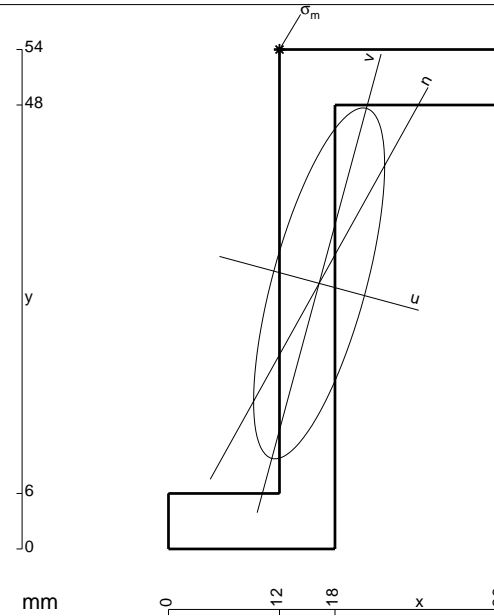

- A = 504. mm²
- J_x = 181471. mm⁴
- J_y = 25303. mm⁴
- J_{xy} = 45545. mm⁴
- J_u = 193783. mm⁴
- J_v = 12991. mm⁴
- α = arctg(2J_{xy}/(J_y-J_x))/2 = -.2640
- c = cos α = .9653
- s = sin α = -.2610
- x_g = 16.29 mm
- y_g = 28.71 mm
- N = -1398. N
- T_y = -1075. N
- M_x = 684775. Nmm
- x_m = 12. mm
- y_m = 54. mm
- u_m = -10.74 mm
- v_m = 23.29 mm
- σ_m = N/A - Mcv/J_u - Msu/J_v = -229.9 N/mm²

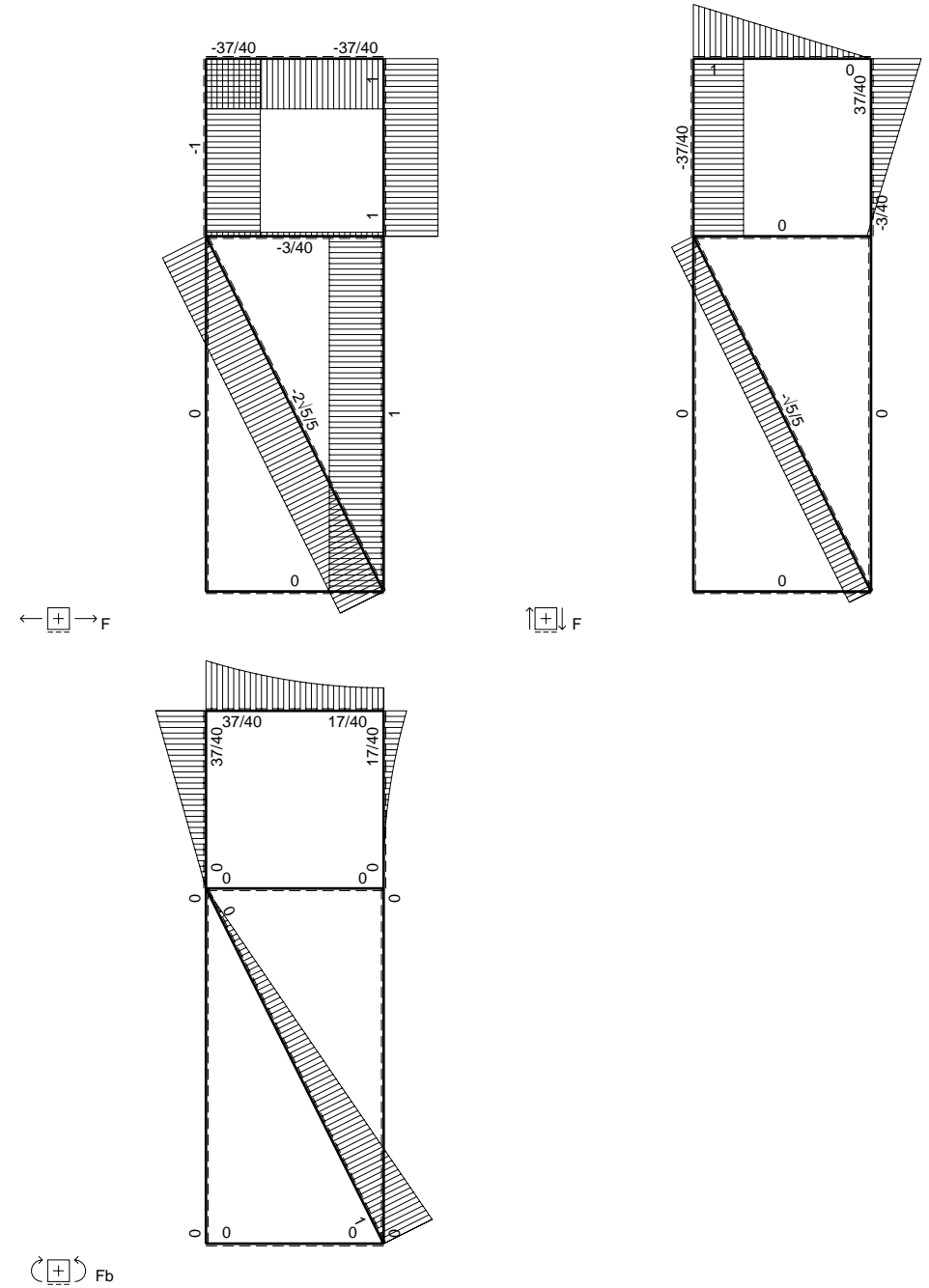
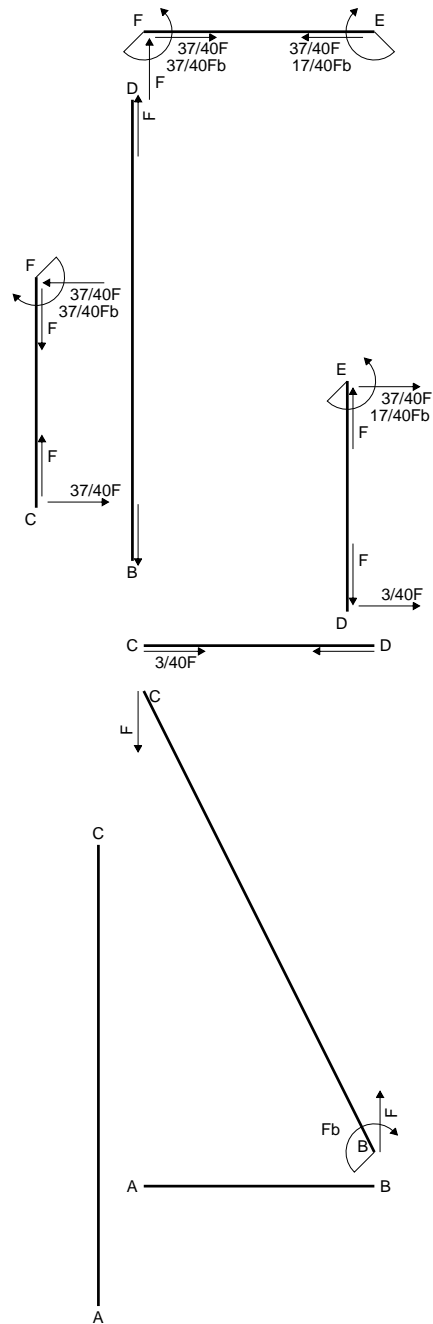

$$L_{DE}^{xx} = \int_0^b (x^2/b^2) 1/EJ dx = [1/3 x^3/b^2]_0^b 1/EJ$$

$$= (1/3 b) 1/EJ = 1/3 b/EJ$$

$$L_{ED}^{xx} = \int_0^b (1 - 2x/b + x^2/b^2) 1/EJ dx = [x - x^2/b + 1/3 x^3/b^2]_0^b 1/EJ$$

$$= (b - b + 1/3 b) 1/EJ = 1/3 b/EJ$$

$$L_{EF}^{xx} = \int_0^b (1) 1/EJ dx = [x]_0^b 1/EJ$$

$$= (b) 1/EJ = b/EJ$$

$$L_{FE}^{xx} = \int_0^b (1) 1/EJ dx = [x]_0^b 1/EJ$$

$$= (b) 1/EJ = b/EJ$$

$$L_{FC}^{xx} = \int_0^b (1 - 2x/b + x^2/b^2) 1/EJ dx = [x - x^2/b + 1/3 x^3/b^2]_0^b 1/EJ$$

$$= (b - b + 1/3 b) 1/EJ = 1/3 b/EJ$$

$$L_{CF}^{xx} = \int_0^b (x^2/b^2) 1/EJ dx = [1/3 x^3/b^2]_0^b 1/EJ$$

$$= (1/3 b) 1/EJ = 1/3 b/EJ$$

$$L_{DE}^{xo} = \int_0^b (1/2 x^2/b^2 - 1/2 x^3/b^3) Fb 1/EJ dx = [1/6 x^3/b^2 - 1/8 x^4/b^3]_0^b Fb 1/EJ$$

$$= (1/6 b - 1/8 b) Fb 1/EJ = 1/24 Fb^2/EJ$$

$$L_{ED}^{xo} = \int_0^b (1/2 x/b - x^2/b^2 + 1/2 x^3/b^3) Fb 1/EJ dx = [1/4 x^2/b - 1/3 x^3/b^2 + 1/8 x^4/b^3]_0^b Fb 1/EJ$$

$$= (1/4 b - 1/3 b + 1/8 b) Fb 1/EJ = 1/24 Fb^2/EJ$$

$$L_{EF}^{xo} = \int_0^b (-1/2 x^2/b^2) Fb 1/EJ dx + \int_0^b (1) \theta dx = [-1/6 x^3/b^2]_0^b Fb 1/EJ + [x]_0^b \theta$$

$$= (-1/6 b) Fb 1/EJ + (b) \theta = 5/6 Fb^2/EJ$$

$$L_{FE}^{xo} = \int_0^b (-1/2 + x/b - 1/2 x^2/b^2) Fb 1/EJ dx + \int_0^b (-1) \theta dx$$

$$= [-1/2 x + 1/2 x^2/b - 1/6 x^3/b^2]_0^b Fb 1/EJ + [-x]_0^b \theta$$

$$= (-1/2 b + 1/2 b - 1/6 b) Fb 1/EJ + (-b) \theta = 5/6 Fb^2/EJ$$

$$L_{FC}^{xo} = \int_0^b (-1/2 + x/b - 1/2 x^2/b^2) Fb 1/EJ dx = [-1/2 x + 1/2 x^2/b - 1/6 x^3/b^2]_0^b Fb 1/EJ$$

$$= (-1/2 b + 1/2 b - 1/6 b) Fb 1/EJ = -1/6 Fb^2/EJ$$

$$L_{CF}^{xo} = \int_0^b (-1/2 x^2/b^2) Fb 1/EJ dx = [-1/6 x^3/b^2]_0^b Fb 1/EJ$$

$$= (-1/6 b) Fb 1/EJ = -1/6 Fb^2/EJ$$

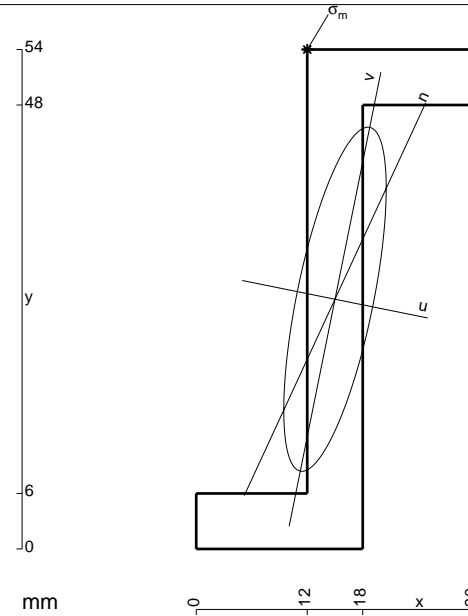

- A = 468. mm²
- J_x = 162108. mm⁴
- J_y = 14364. mm⁴
- J_{xy} = 31104. mm⁴
- J_u = 168389. mm⁴
- J_v = 8083. mm⁴
- α = arctg(2J_{xy}/(J_y-J_x))/2 = -.1993
- c = cos α = .9802
- s = sin α = -.1979
- x_g = 15. mm
- y_g = 27. mm
- N = -1127. N
- T_y = -563.5 N
- M_x = 667800. Nmm
- x_m = 12. mm
- y_m = 54. mm
- u_m = -8.285 mm
- v_m = 25.87 mm
- σ_m = N/A - Mc_v/J_u - Ms_u/J_v = -238.5 N/mm²

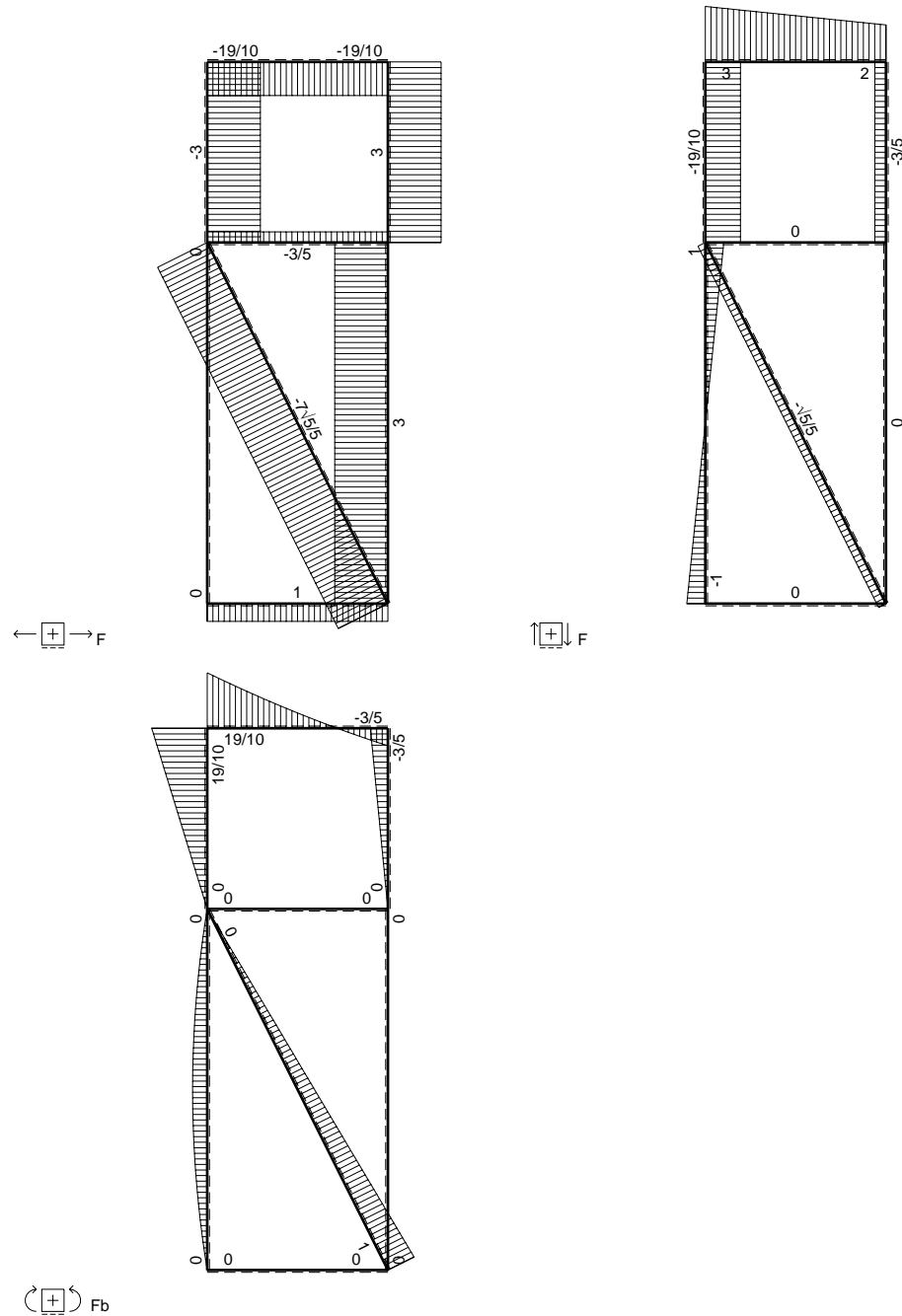
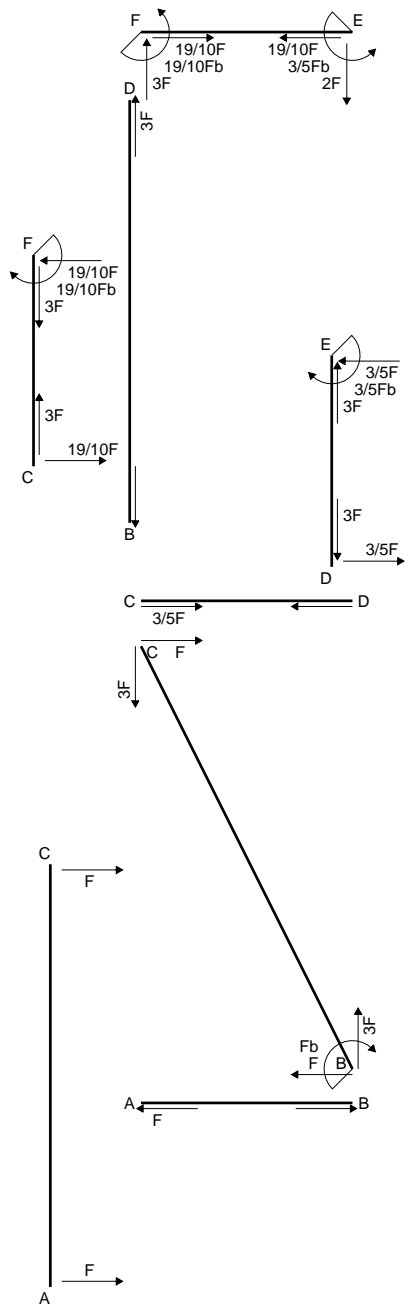

Legend for internal force diagrams: $\left[\begin{matrix} + \\ + \end{matrix} \right] F$ and $\left[\begin{matrix} + \\ + \end{matrix} \right] F_b$

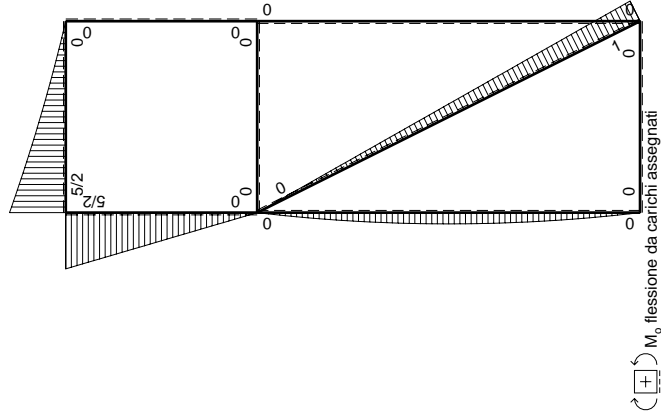
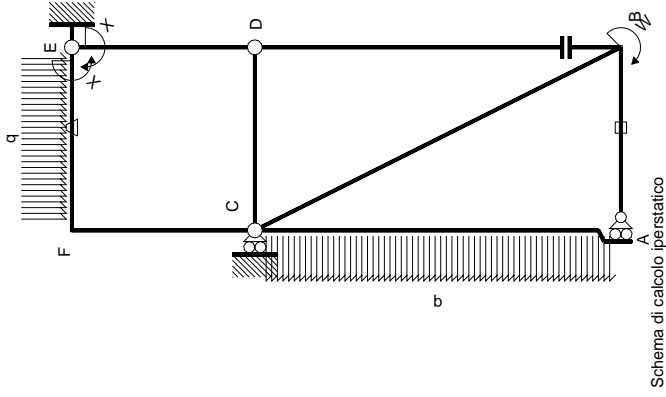

M_x , flessione da iperstatica $X=1$

\leftarrow	$M^x(x)$	$M_0(x)$	θ	Quadro contributi PLV per iperstatica $X=W_{EP}$		$M_x M_0$	$M_x \theta$	$M_x M_x$	$\int M_x(M_0/EJ+\theta)dx$	$\int M_x M_x/EJdx$	Sviluppi di calcolo iperstatica																										
				AB B	BA B						BC $\sqrt{5}b$	AC 2b	CA 2b	DB 2b	BD 2b	DE b	ED b	CD b	DC b	FE b	FC b	CF b	totali	iperstatica $X=W_{EP}$													
AB B	0	0	0	0	0	0	0	0	0	0	0	0	0	0	0	0	0	0	0	0	0	0	0	0	0	0	0	0									
BA B	0	0	0	0	0	0	0	0	0	0	0	0	0	0	0	0	0	0	0	0	0	0	0	0	0	0	0	0	0								
BC $\sqrt{5}b$	0	0	0	0	0	0	0	0	0	0	0	0	0	0	0	0	0	0	0	0	0	0	0	0	0	0	0	0	0	0							
AC 2b	0	0	0	0	0	0	0	0	0	0	0	0	0	0	0	0	0	0	0	0	0	0	0	0	0	0	0	0	0	0	0						
CA 2b	0	0	0	0	0	0	0	0	0	0	0	0	0	0	0	0	0	0	0	0	0	0	0	0	0	0	0	0	0	0	0	0					
DB 2b	0	0	0	0	0	0	0	0	0	0	0	0	0	0	0	0	0	0	0	0	0	0	0	0	0	0	0	0	0	0	0	0					
BD 2b	0	0	0	0	0	0	0	0	0	0	0	0	0	0	0	0	0	0	0	0	0	0	0	0	0	0	0	0	0	0	0	0	0				
DE b	0	0	0	0	0	0	0	0	0	0	0	0	0	0	0	0	0	0	0	0	0	0	0	0	0	0	0	0	0	0	0	0	0				
ED b	0	0	0	0	0	0	0	0	0	0	0	0	0	0	0	0	0	0	0	0	0	0	0	0	0	0	0	0	0	0	0	0	0				
CD b	0	0	0	0	0	0	0	0	0	0	0	0	0	0	0	0	0	0	0	0	0	0	0	0	0	0	0	0	0	0	0	0	0	0			
DC b	0	0	0	0	0	0	0	0	0	0	0	0	0	0	0	0	0	0	0	0	0	0	0	0	0	0	0	0	0	0	0	0	0	0			
FE b	-1	-Fb/EJ	$2Fx+1/2qx^2$	$-Fx+1/2qx^2$	$-Fb-5/5Fx$	0	0	0	0	0	0	0	0	0	0	0	0	0	0	0	0	0	0	0	0	0	0	0	0	0	0	0	0	0			
FC b	-1+x/b	$-5/2Fb+3Fx-1/2qx^2$	$5/2Fb-5/2Fx$	$-5/2Fb+5Fx-5/2Fx^2/b$	0	0	0	0	0	0	0	0	0	0	0	0	0	0	0	0	0	0	0	0	0	0	0	0	0	0	0	0	0	0	0		
CF b	x/b	$-5/2Fx$	0	0	0	0	0	0	0	0	0	0	0	0	0	0	0	0	0	0	0	0	0	0	0	0	0	0	0	0	0	0	0	0	0		
totali																																					

Sviluppi di calcolo iperstatica

$$L_{DE}^{xx} = \int_0^b (x^2/b^2) 1/EJ dx = [1/3 x^3/b^2]_0^b 1/EJ$$

$$= (1/3 b) 1/EJ = 1/3 b/EJ$$

$$L_{ED}^{xx} = \int_0^b (1 - 2x/b + x^2/b^2) 1/EJ dx = [x - x^2/b + 1/3 x^3/b^2]_0^b 1/EJ$$

$$= (b - b + 1/3 b) 1/EJ = 1/3 b/EJ$$

$$L_{EF}^{xx} = \int_0^b (1) 1/EJ dx = [x]_0^b 1/EJ$$

$$= (b) 1/EJ = b/EJ$$

$$L_{FE}^{xx} = \int_0^b (1) 1/EJ dx = [x]_0^b 1/EJ$$

$$= (b) 1/EJ = b/EJ$$

$$L_{FC}^{xx} = \int_0^b (1 - 2x/b + x^2/b^2) 1/EJ dx = [x - x^2/b + 1/3 x^3/b^2]_0^b 1/EJ$$

$$= (b - b + 1/3 b) 1/EJ = 1/3 b/EJ$$

$$L_{CF}^{xx} = \int_0^b (x^2/b^2) 1/EJ dx = [1/3 x^3/b^2]_0^b 1/EJ$$

$$= (1/3 b) 1/EJ = 1/3 b/EJ$$

$$L_{EF}^{xo} = \int_0^b (-2x/b - 1/2 x^2/b^2) Fb 1/EJ dx + \int_0^b (1) \theta dx = [-x^2/b - 1/6 x^3/b^2]_0^b Fb 1/EJ + [x]_0^b \theta$$

$$= (-b - 1/6 b) Fb 1/EJ + (b) \theta = -1/6 Fb^2/EJ$$

$$L_{FE}^{xo} = \int_0^b (-5/2 + 3x/b - 1/2 x^2/b^2) Fb 1/EJ dx + \int_0^b (-1) \theta dx$$

$$= [-5/2 x + 3/2 x^2/b - 1/6 x^3/b^2]_0^b Fb 1/EJ + [-x]_0^b \theta$$

$$= (-5/2 b + 3/2 b - 1/6 b) Fb 1/EJ + (-b) \theta = -1/6 Fb^2/EJ$$

$$L_{FC}^{xo} = \int_0^b (-5/2 + 5x/b - 5/2 x^2/b^2) Fb 1/EJ dx = [-5/2 x + 5/2 x^2/b - 5/6 x^3/b^2]_0^b Fb 1/EJ$$

$$= (-5/2 b + 5/2 b - 5/6 b) Fb 1/EJ = -5/6 Fb^2/EJ$$

$$L_{CF}^{xo} = \int_0^b (-5/2 x^2/b^2) Fb 1/EJ dx = [-5/6 x^3/b^2]_0^b Fb 1/EJ$$

$$= (-5/6 b) Fb 1/EJ = -5/6 Fb^2/EJ$$

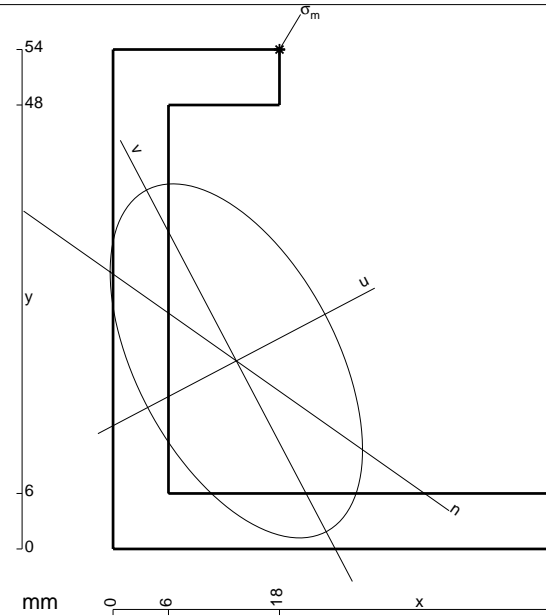

- A = 648. mm²
- J_x = 237528. mm⁴
- J_y = 120672. mm⁴
- J_{xy} = -84960. mm⁴
- J_u = 282212. mm⁴
- J_v = 75988. mm⁴
- α = artg(2J_{xy}/(J_y-J_x))/2 = .4842
- c = cos α = .8851
- s = sin α = .4655
- x_g = 13.33 mm
- y_g = 20.33 mm
- N = -2610. N
- T_y = -1653. N
- M_x = 942210. Nmm
- x_m = 18. mm
- y_m = 54. mm
- u_m = 19.8 mm
- v_m = 27.62 mm
- σ_m = N/A - Mcv/J_u - Msu/J_v = -199.9 N/mm²

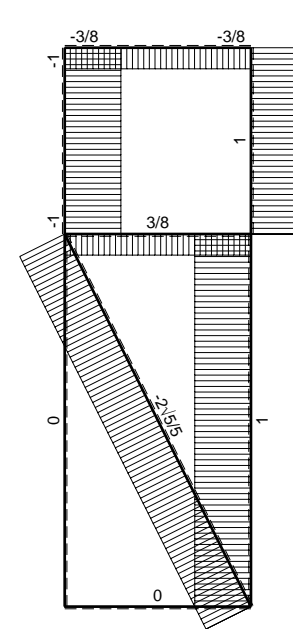
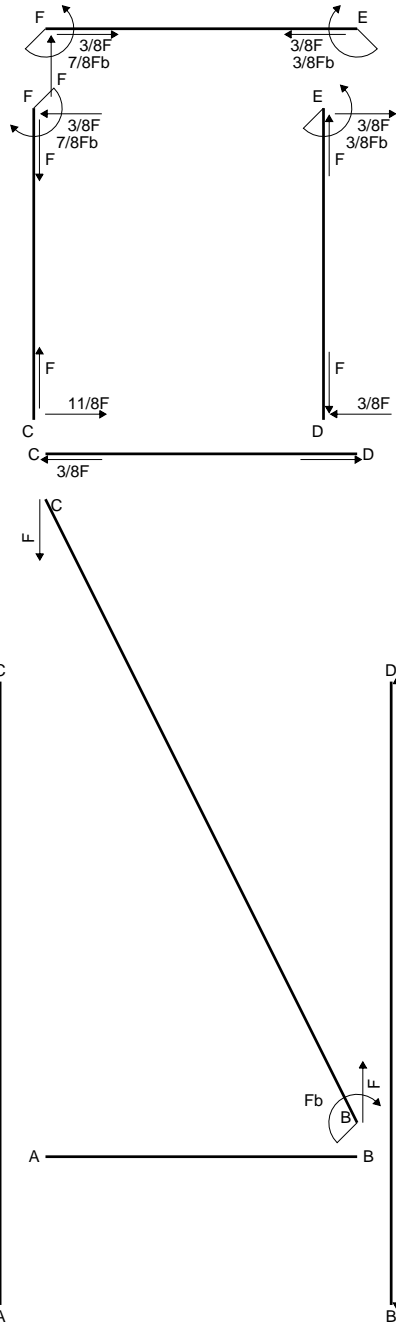

← ⊕ → F

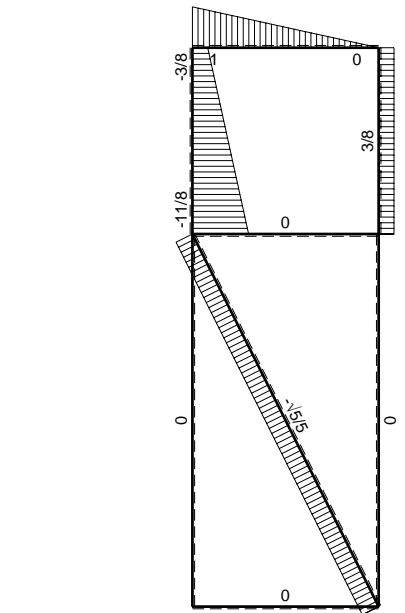

↑ ⊕ ↓ F

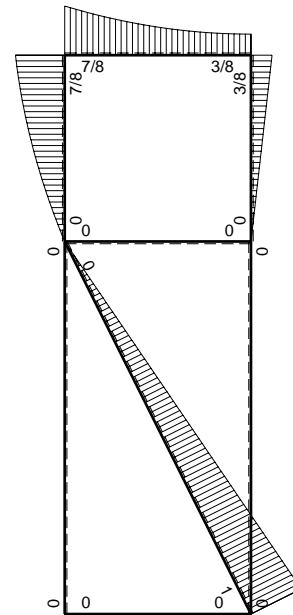

⊕ F_b

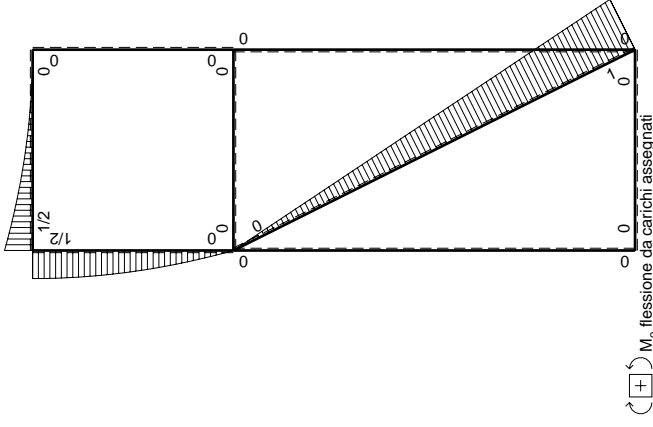
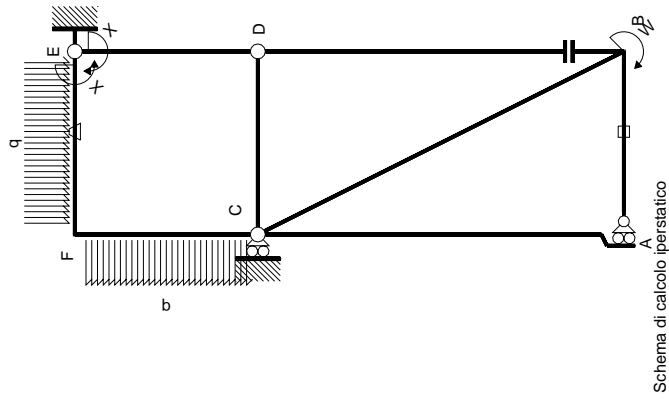

Quadro contributi PLV per iperstatica $X=W_{EF}$		$M^x(x)$		$M^0(x)$	θ	M^x_0	M^x_θ	$M^x X$	$\int M^x(M^0/EJ+\theta)dx$	$\int X M^x M^0/EJ dx$
←	$M^x(x)$	0	0	0	0	0	0	0	0	0
AB	0	0	0	0	0	0	0	0	0	0
BA	0	0	0	0	0	0	0	0	0	0
BC	$-Fb-\sqrt{5}/5Fx$	0	0	0	0	0	0	0	0	0
AC	0	0	0	0	0	0	0	0	0	0
CA	0	0	0	0	0	0	0	0	0	0
DB	0	0	0	0	0	0	0	0	0	0
BD	0	0	0	0	0	0	0	0	0	0
DE	$-x/b$	0	0	0	0	0	0	0	0	0
ED	$1-x/b$	0	0	0	0	0	0	0	0	0
CD	0	0	0	0	0	0	0	0	0	0
DC	0	0	0	0	0	0	0	0	0	0
EF	-1	$1/2qx^2$	$-Fb/EJ$	$-1/2Fx^2/b$	Fb/EJ	1	1	$(-1/6+1)Fb^2/EJ$	Xb/EJ	$1/3Xb/EJ$
FE	1	$-1/2Fb+Fx-1/2qx^2$	Fb/EJ	$-1/2Fb+Fx-1/2Fx^2/b$	Fb/EJ	1	1	$(-5/24+0)Fb^2/EJ$	Xb/EJ	$1/3Xb/EJ$
FC	$-1+x/b$	$1/2Fb-1/2qx^2$	0	$-1/2Fb+1/2Fx+1/2Fx^2/b-1/2qx^3/b$	0	0	0	$-5/8Fb^2/EJ$	$5/3Xb/EJ$	$1/3Xb/EJ$
CF	x/b	$-Fx+1/2qx^2$	0	$-Fx^2/b+1/2qx^3/b$	0	0	0	$-3/8Fb$	$5/3Xb/EJ$	$1/3Xb/EJ$
totali										
		iperstatica $X=W_{EF}$								

Sviluppi di calcolo iperstatica

$$L_{DE}^{xx} = \int_0^b (x^2/b^2) 1/EJ dx = [1/3 x^3/b^2]_0^b 1/EJ$$

$$= (1/3 b) 1/EJ = 1/3 b/EJ$$

$$L_{ED}^{xx} = \int_0^b (1 - 2x/b + x^2/b^2) 1/EJ dx = [x - x^2/b + 1/3 x^3/b^2]_0^b 1/EJ$$

$$= (b - b + 1/3 b) 1/EJ = 1/3 b/EJ$$

$$L_{EF}^{xx} = \int_0^b (1) 1/EJ dx = [x]_0^b 1/EJ$$

$$= (b) 1/EJ = b/EJ$$

$$L_{FE}^{xx} = \int_0^b (1) 1/EJ dx = [x]_0^b 1/EJ$$

$$= (b) 1/EJ = b/EJ$$

$$L_{FC}^{xx} = \int_0^b (1 - 2x/b + x^2/b^2) 1/EJ dx = [x - x^2/b + 1/3 x^3/b^2]_0^b 1/EJ$$

$$= (b - b + 1/3 b) 1/EJ = 1/3 b/EJ$$

$$L_{CF}^{xx} = \int_0^b (x^2/b^2) 1/EJ dx = [1/3 x^3/b^2]_0^b 1/EJ$$

$$= (1/3 b) 1/EJ = 1/3 b/EJ$$

$$L_{EF}^{xo} = \int_0^b (-1/2 x^2/b^2) Fb 1/EJ dx + \int_0^b (1) \theta dx = [-1/6 x^3/b^2]_0^b Fb 1/EJ + [x]_0^b \theta$$

$$= (-1/6 b) Fb 1/EJ + (b) \theta = 5/6 Fb^2/EJ$$

$$L_{FE}^{xo} = \int_0^b (-1/2 + x/b - 1/2 x^2/b^2) Fb 1/EJ dx + \int_0^b (-1) \theta dx$$

$$= [-1/2 x + 1/2 x^2/b - 1/6 x^3/b^2]_0^b Fb 1/EJ + [-x]_0^b \theta$$

$$= (-1/2 b + 1/2 b - 1/6 b) Fb 1/EJ + (-b) \theta = 5/6 Fb^2/EJ$$

$$L_{FC}^{xo} = \int_0^b (-1/2 + 1/2 x/b + 1/2 x^2/b^2 - 1/2 x^3/b^3) Fb 1/EJ dx$$

$$= [-1/2 x + 1/4 x^2/b + 1/6 x^3/b^2 - 1/8 x^4/b^3]_0^b Fb 1/EJ$$

$$= (-1/2 b + 1/4 b + 1/6 b - 1/8 b) Fb 1/EJ = -5/24 Fb^2/EJ$$

$$L_{CF}^{xo} = \int_0^b (-x^2/b^2 + 1/2 x^3/b^3) Fb 1/EJ dx = [-1/3 x^3/b^2 + 1/8 x^4/b^3]_0^b Fb 1/EJ$$

$$= (-1/3 b + 1/8 b) Fb 1/EJ = -5/24 Fb^2/EJ$$

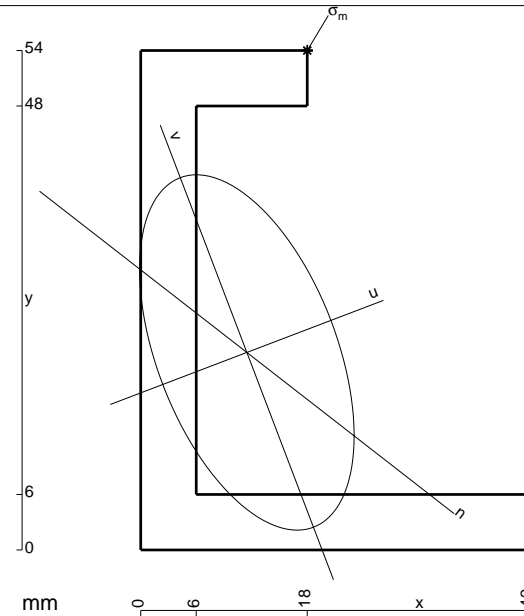

- A = 612. mm²
- J_x = 225968. mm⁴
- J_y = 82341. mm⁴
- J_{xy} = -64038. mm⁴
- J_u = 250373. mm⁴
- J_v = 57936. mm⁴
- α = arctg(2J_{xy}/(J_y-J_x))/2 = .3641
- c = cos α = .9344
- s = sin α = .3561
- x_g = 11.47 mm
- y_g = 21.35 mm
- N = -1440. N
- T_y = -720. N
- M_x = 966000. Nmm
- x_m = 18. mm
- y_m = 54. mm
- u_m = 17.73 mm
- v_m = 28.18 mm
- σ_m = N/A - Mcv/J_u - Msu/J_v = -209.2 N/mm²

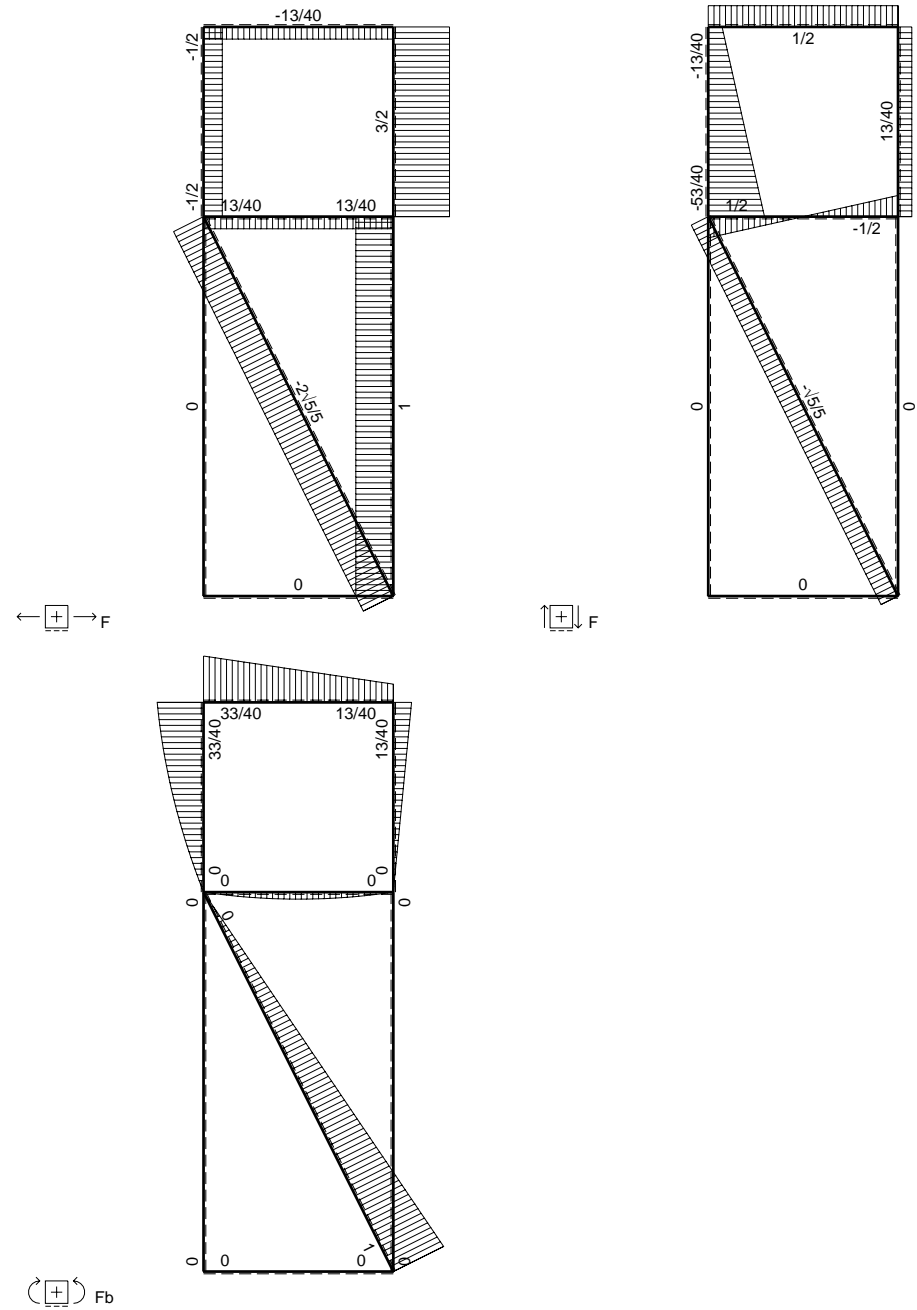
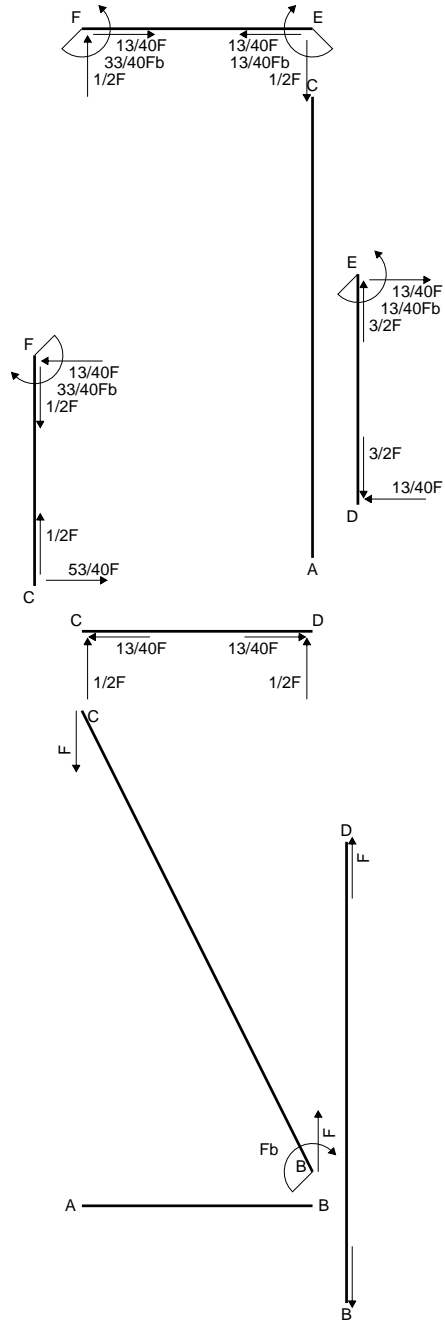

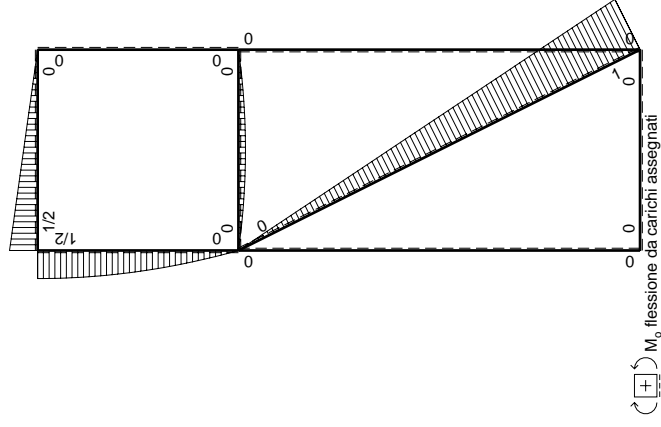
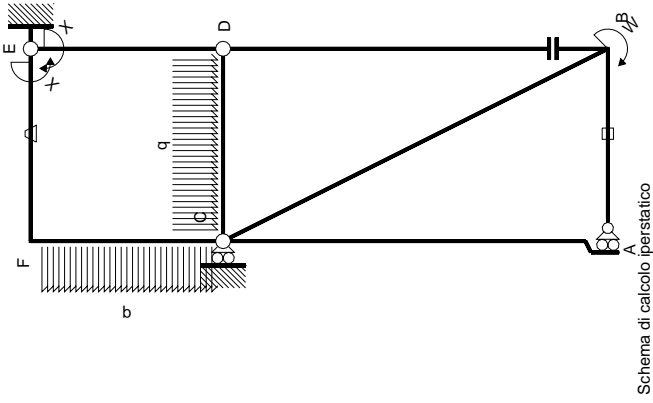

M_x flessione da iperstatica X=1

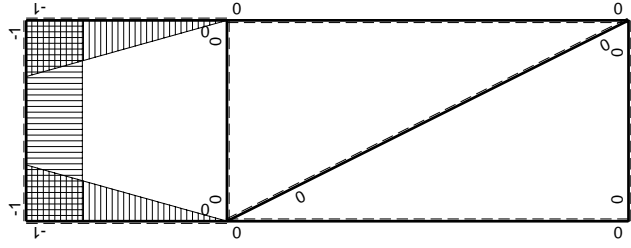

Quadro contributi PLV per iperstatica X=W^{EF}

←	M _x (x)	M ₀ (x)	θ	M _x θ	M _x M ₀	∫M _x (M ₀ /EJ+θ)dx	∫M _x M ₀ /EJdx
AB b	0	0	0	0	0	0	0
BA b	0	0	0	0	0	0	0
BC √5b	0	Fb-√5/5Fx	0	0	0	0	0
CA 2b	0	0	0	0	0	0	0
DB 2b	0	0	0	0	0	0	0
BD 2b	0	0	0	0	0	0	0
DE b	-x/b	0	0	0	x ² /b ²	0	1/3Xb/EJ
ED b	1-x/b	0	0	0	1-2x/b+x ² /b ²	0	1/3Xb/EJ
CD b	0	1/2Fx-1/2qx ²	0	0	0	0	0
DC b	0	-1/2Fx+1/2qx ²	0	0	0	0	0
EF b	-1	1/2Fx	-Fb/EJ	-1/2Fx	Fb/EJ	1	Xb/EJ
FE b	1	-1/2Fb+1/2Fx	Fb/EJ	-1/2Fb+1/2Fx	Fb/EJ	1	(-1/4+1)Fb ² /EJ
FC b	-1+x/b	1/2Fb-1/2qx ²	0	-1/2Fb+1/2Fx+1/2Fx ² /b-1/2qx ³ /b	0	1-2x/b+x ² /b ²	(-5/24+0)Fb ² /EJ
CF b	x/b	-Fx+1/2qx ²	0	-Fx ² /b+1/2qx ³ /b	0	x ² /b ²	1/3Xb/EJ
totali							13/24Fb ² /EJ
							5/3Xb/EJ
							-13/40Fb

Sviluppi di calcolo iperstatica

$$L_{DE}^{xx} = \int_0^b (x^2/b^2) 1/EJ dx = [1/3 x^3/b^2]_0^b 1/EJ$$

$$= (1/3 b) 1/EJ = 1/3 b/EJ$$

$$L_{ED}^{xx} = \int_0^b (1 - 2x/b + x^2/b^2) 1/EJ dx = [x - x^2/b + 1/3 x^3/b^2]_0^b 1/EJ$$

$$= (b - b + 1/3 b) 1/EJ = 1/3 b/EJ$$

$$L_{EF}^{xx} = \int_0^b (1) 1/EJ dx = [x]_0^b 1/EJ$$

$$= (b) 1/EJ = b/EJ$$

$$L_{FE}^{xx} = \int_0^b (1) 1/EJ dx = [x]_0^b 1/EJ$$

$$= (b) 1/EJ = b/EJ$$

$$L_{FC}^{xx} = \int_0^b (1 - 2x/b + x^2/b^2) 1/EJ dx = [x - x^2/b + 1/3 x^3/b^2]_0^b 1/EJ$$

$$= (b - b + 1/3 b) 1/EJ = 1/3 b/EJ$$

$$L_{CF}^{xx} = \int_0^b (x^2/b^2) 1/EJ dx = [1/3 x^3/b^2]_0^b 1/EJ$$

$$= (1/3 b) 1/EJ = 1/3 b/EJ$$

$$L_{EF}^{xo} = \int_0^b (-1/2 x/b) Fb 1/EJ dx + \int_0^b (1) \theta dx = [-1/4 x^2/b]_0^b Fb 1/EJ + [x]_0^b \theta$$

$$= (-1/4 b) Fb 1/EJ + (b) \theta = 3/4 Fb^2/EJ$$

$$L_{FE}^{xo} = \int_0^b (-1/2 + 1/2 x/b) Fb 1/EJ dx + \int_0^b (-1) \theta dx = [-1/2 x + 1/4 x^2/b]_0^b Fb 1/EJ + [-x]_0^b \theta$$

$$= (-1/2 b + 1/4 b) Fb 1/EJ + (-b) \theta = 3/4 Fb^2/EJ$$

$$L_{FC}^{xo} = \int_0^b (-1/2 + 1/2 x/b + 1/2 x^2/b^2 - 1/2 x^3/b^3) Fb 1/EJ dx$$

$$= [-1/2 x + 1/4 x^2/b + 1/6 x^3/b^2 - 1/8 x^4/b^3]_0^b Fb 1/EJ$$

$$= (-1/2 b + 1/4 b + 1/6 b - 1/8 b) Fb 1/EJ = -5/24 Fb^2/EJ$$

$$L_{CF}^{xo} = \int_0^b (-x^2/b^2 + 1/2 x^3/b^3) Fb 1/EJ dx = [-1/3 x^3/b^2 + 1/8 x^4/b^3]_0^b Fb 1/EJ$$

$$= (-1/3 b + 1/8 b) Fb 1/EJ = -5/24 Fb^2/EJ$$

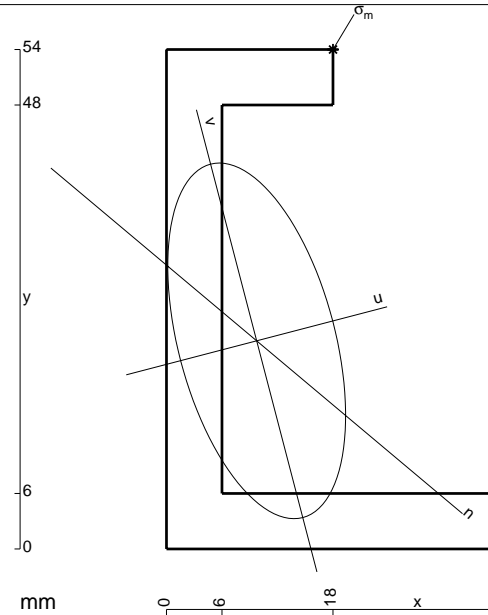

- A = 576. mm²
- J_x = 212976. mm⁴
- J_y = 53244. mm⁴
- J_{xy} = -44712. mm⁴
- J_u = 224640. mm⁴
- J_v = 41580. mm⁴
- α = arctg(2J_{xy}/(J_y-J_x))/2 = .2552
- c = cos α = .9676
- s = sin α = .2524
- x_g = 9.75 mm
- y_g = 22.5 mm
- N = -1386. N
- T_y = -693.2 N
- M_x = 992000. Nmm
- x_m = 18. mm
- y_m = 54. mm
- u_m = 15.93 mm
- v_m = 28.4 mm
- σ_m = N/A - Mcv/J_u - Msu/J_v = -219.7 N/mm²

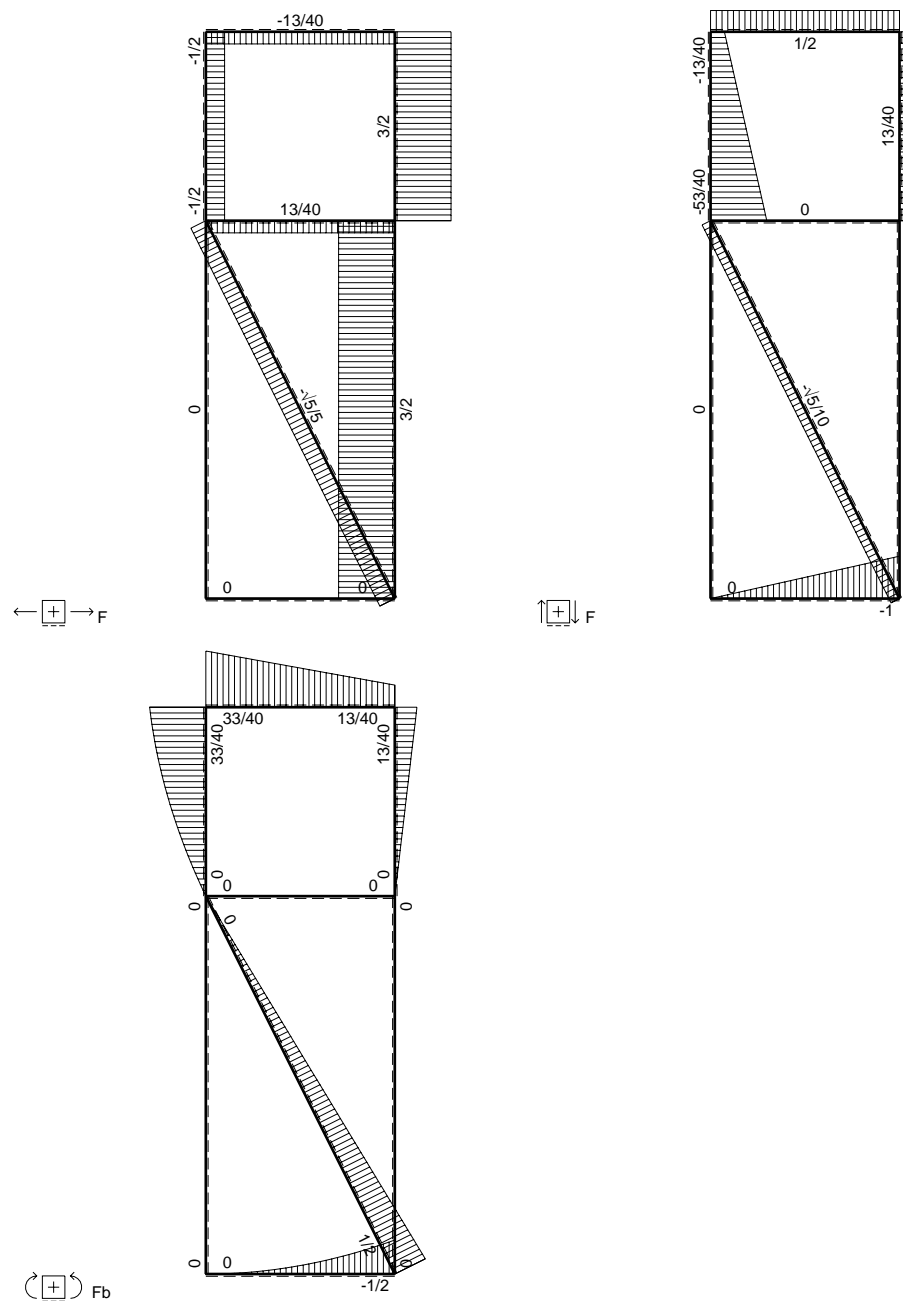
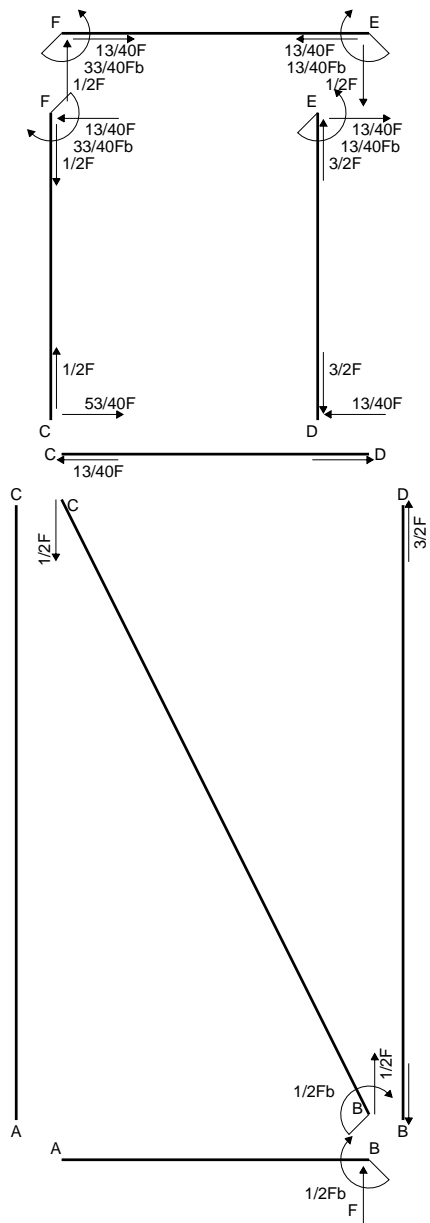

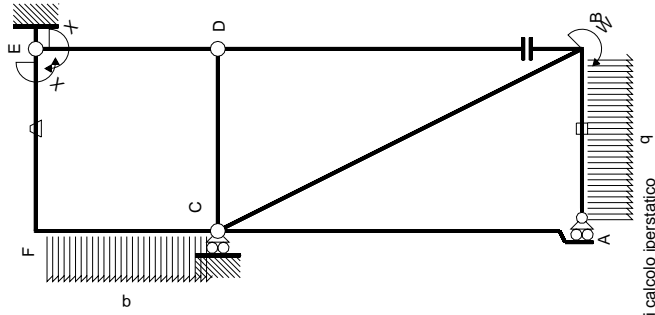

M_0 flessione da carichi assegnati

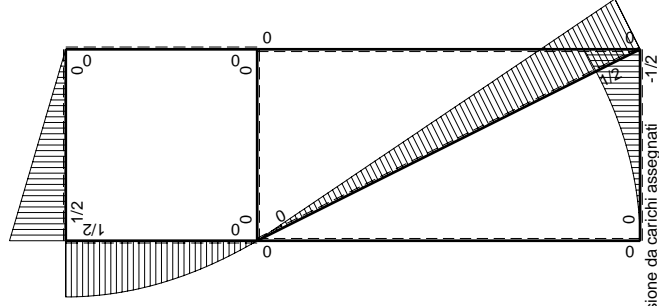

M_x flessione da iperstatica $X=1$

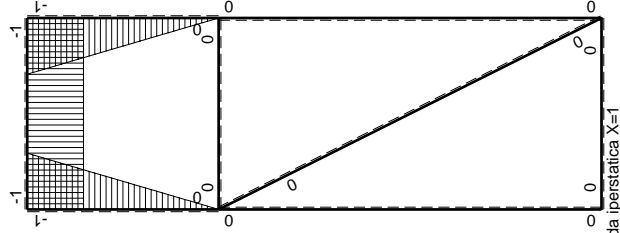

Sviluppi di calcolo iperstatica

Quadro contributi PLV per iperstatica $X=W_{EF}$

\rightarrow	$M^x(x)$	$M^0(x)$	θ	$M^x M_0$	$M^x \theta$	$M^x M_x$	$\int M^x (M_0/EJ + \theta) dx$	$\int M^x M_x / E dx$
AB b	0	$-1/2qx^2$	0	0	0	0	0	0
BA b	0	$1/2Fb - Fx + 1/2qx^2$	0	0	0	0	0	0
BC $\sqrt{5}b$	0	$1/2Fb - \sqrt{5}/10Fx$	0	0	0	0	0	0
AC 2b	0	0	0	0	0	0	0	0
CA 2b	0	0	0	0	0	0	0	0
DB 2b	0	0	0	0	0	0	0	0
BD 2b	0	0	0	0	0	0	0	0
DE b	-x/b	0	0	0	0	x^2/b^2	0	0
ED b	1-x/b	0	0	0	0	$1-2x/b+x^2/b^2$	0	0
CD b	0	0	0	0	0	0	0	0
DC b	0	0	0	0	0	0	0	0
EF b	-1	$1/2Fx$	-Fb/EJ	-1/2Fx	Fb/EJ	1	$(-1/4+1)Fb^2/EJ$	Xb/EJ
FE b	1	$-1/2Fb+1/2Fx$	Fb/EJ	$-1/2Fb+1/2Fx$	Fb/EJ	1	$(-1/4+1)Fb^2/EJ$	Xb/EJ
FC b	-1+x/b	$1/2Fb-1/2qx^2$	0	$-1/2Fb+1/2Fx+1/2Fx^2/b-1/2qx^3/b$	0	$1-2x/b+x^2/b^2$	$(-5/24+0)Fb^2/EJ$	$1/3Xb/EJ$
CF b	x/b	$-Fx+1/2qx^2$	0	$-Fx^2/b+1/2qx^3/b$	0	x^2/b^2	$13/24Fb^2/EJ$	$5/3Xb/EJ$
totali								
iperstatica $X=W_{EF}$								

$$L_{DE}^{xx} = \int_0^b (x^2/b^2) 1/EJ dx = [1/3 x^3/b^2]_0^b 1/EJ$$

$$= (1/3 b) 1/EJ = 1/3 b/EJ$$

$$L_{ED}^{xx} = \int_0^b (1 - 2x/b + x^2/b^2) 1/EJ dx = [x - x^2/b + 1/3 x^3/b^2]_0^b 1/EJ$$

$$= (b - b + 1/3 b) 1/EJ = 1/3 b/EJ$$

$$L_{EF}^{xx} = \int_0^b (1) 1/EJ dx = [x]_0^b 1/EJ$$

$$= (b) 1/EJ = b/EJ$$

$$L_{FE}^{xx} = \int_0^b (1) 1/EJ dx = [x]_0^b 1/EJ$$

$$= (b) 1/EJ = b/EJ$$

$$L_{FC}^{xx} = \int_0^b (1 - 2x/b + x^2/b^2) 1/EJ dx = [x - x^2/b + 1/3 x^3/b^2]_0^b 1/EJ$$

$$= (b - b + 1/3 b) 1/EJ = 1/3 b/EJ$$

$$L_{CF}^{xx} = \int_0^b (x^2/b^2) 1/EJ dx = [1/3 x^3/b^2]_0^b 1/EJ$$

$$= (1/3 b) 1/EJ = 1/3 b/EJ$$

$$L_{EF}^{xo} = \int_0^b (-1/2 x/b) Fb 1/EJ dx + \int_0^b (1) \theta dx = [-1/4 x^2/b]_0^b Fb 1/EJ + [x]_0^b \theta$$

$$= (-1/4 b) Fb 1/EJ + (b) \theta = 3/4 Fb^2/EJ$$

$$L_{FE}^{xo} = \int_0^b (-1/2 + 1/2 x/b) Fb 1/EJ dx + \int_0^b (-1) \theta dx = [-1/2 x + 1/4 x^2/b]_0^b Fb 1/EJ + [-x]_0^b \theta$$

$$= (-1/2 b + 1/4 b) Fb 1/EJ + (-b) \theta = 3/4 Fb^2/EJ$$

$$L_{FC}^{xo} = \int_0^b (-1/2 + 1/2 x/b + 1/2 x^2/b^2 - 1/2 x^3/b^3) Fb 1/EJ dx$$

$$= [-1/2 x + 1/4 x^2/b + 1/6 x^3/b^2 - 1/8 x^4/b^3]_0^b Fb 1/EJ$$

$$= (-1/2 b + 1/4 b + 1/6 b - 1/8 b) Fb 1/EJ = -5/24 Fb^2/EJ$$

$$L_{CF}^{xo} = \int_0^b (-x^2/b^2 + 1/2 x^3/b^3) Fb 1/EJ dx = [-1/3 x^3/b^2 + 1/8 x^4/b^3]_0^b Fb 1/EJ$$

$$= (-1/3 b + 1/8 b) Fb 1/EJ = -5/24 Fb^2/EJ$$

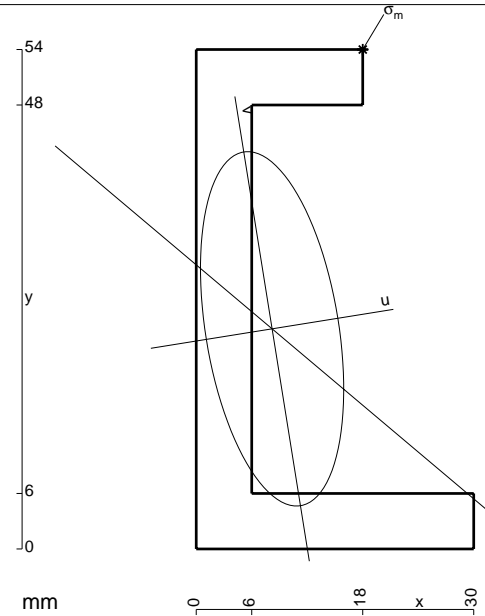

$A = 540. \text{ mm}^2$
 $J_x = 198266. \text{ mm}^4$
 $J_y = 32378. \text{ mm}^4$
 $J_{xy} = -27302. \text{ mm}^4$
 $J_u = 202644. \text{ mm}^4$
 $J_v = 28000. \text{ mm}^4$
 $\alpha = \text{artg}(2J_{xy}/(J_y - J_x))/2 = .1590$
 $c = \cos \alpha = .9874$
 $s = \sin \alpha = .1583$
 $x_g = 8.2 \text{ mm}$
 $y_g = 23.8 \text{ mm}$
 $N = -925. \text{ N}$
 $T_y = -601.3 \text{ N}$
 $M_x = 1037850. \text{ Nmm}$
 $x_m = 18. \text{ mm}$
 $y_m = 54. \text{ mm}$
 $u_m = 14.46 \text{ mm}$
 $v_m = 28.27 \text{ mm}$
 $\sigma_m = N/A - Mcv/J_u - Msu/J_v = -229.5 \text{ N/mm}^2$

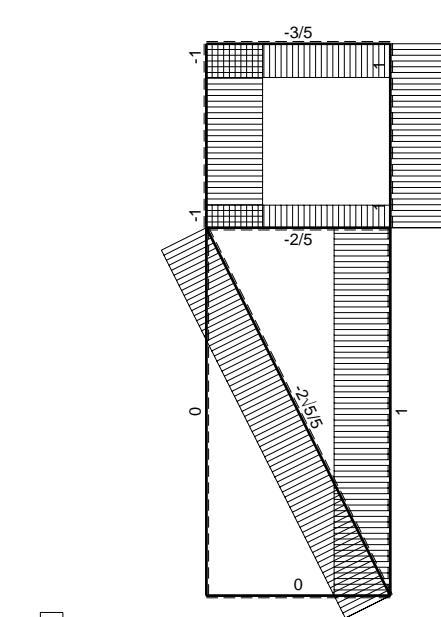
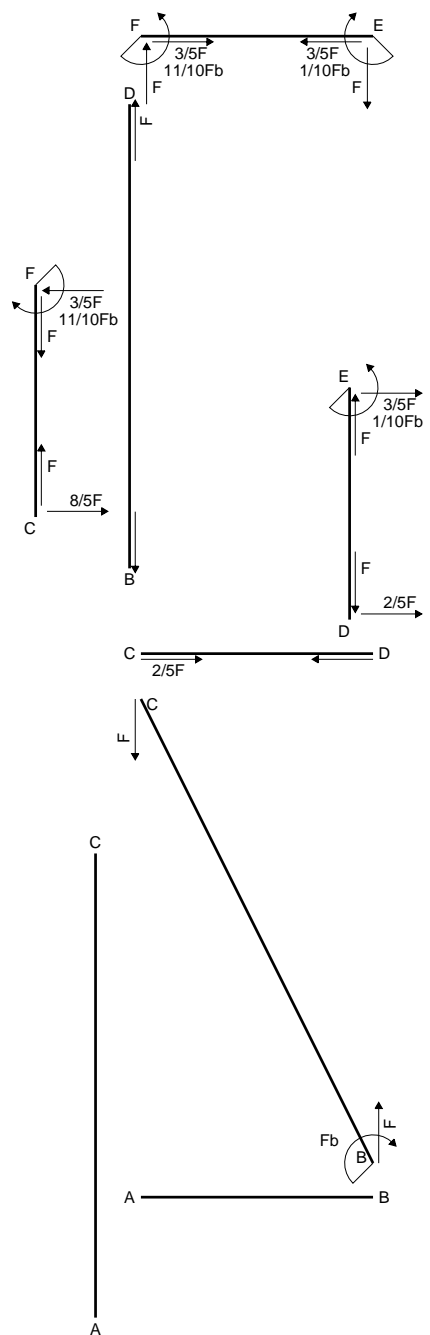

← ⊕ → F

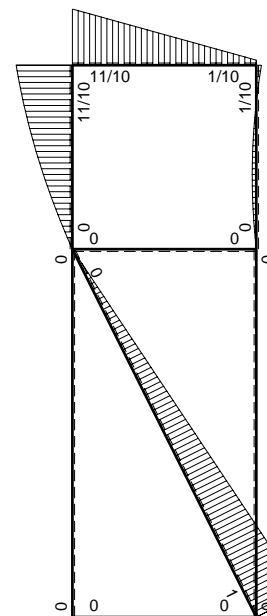

⊕ ↺ F_b

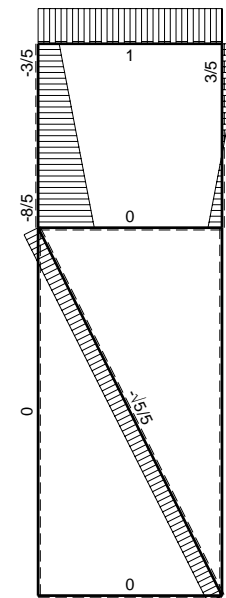

↑ ⊕ ↓ F

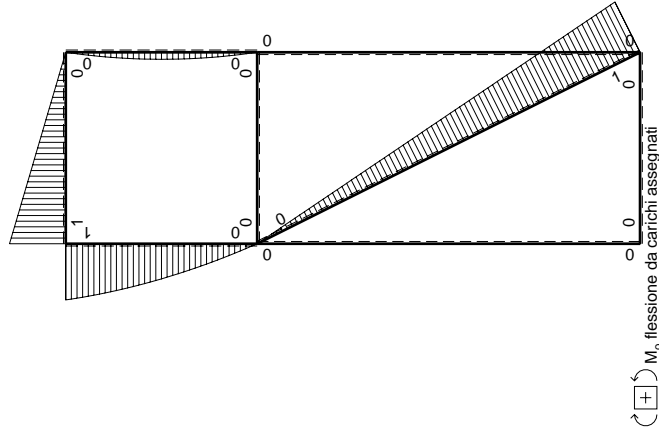
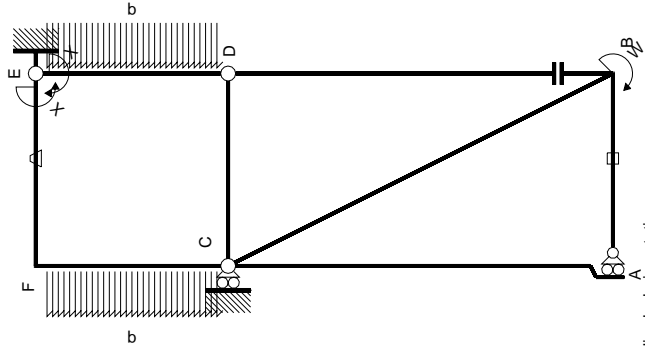

←	iperstatica $X=W_{EF}$						totali		iperstatica $X=W_{EF}$
	$M^x(x)$	$M^0(x)$	θ	$M^x M_0$	$M^x \theta$	$M^x M_x$	$\int M^x(M_0/EJ+\theta)dx$	$\int M^x M_x/EJdx$	
AB b	0	0	0	0	0	0	0	0	
BA b	0	0	0	0	0	0	0	0	
BC $\sqrt{5}b$	0	$Fb-\sqrt{5}/5Fx$	0	0	0	0	0	0	
CA 2b	0	0	0	0	0	0	0	0	
AC 2b	0	0	0	0	0	0	0	0	
DB 2b	0	0	0	0	0	0	0	0	
BD 2b	0	0	0	0	0	0	0	0	
DE b	$-x/b$	$-1/2Fx+1/2qx^2$	0	$1/2Fx^2/b-1/2qx^3/b$	0	x^2/b^2	$(1/24+0)Fb^2/EJ$	$1/3Xb/EJ$	
ED b	$1-x/b$	$1/2Fx-1/2qx^2$	0	$1/2Fx-Fx^2/b+1/2qx^3/b$	0	$1-2x/b+x^2/b^2$	$(1/24+0)Fb^2/EJ$	$1/3Xb/EJ$	
CD b	0	0	0	0	0	0	0	0	
DC b	0	0	0	0	0	0	0	0	
EF b	-1	Fx	$-Fb/EJ$	-Fx	Fb/EJ	1	$(-1/2+1)Fb^2/EJ$	Xb/EJ	
FE b	1	$-Fb+Fx$	Fb/EJ	$-Fb+Fx$	Fb/EJ	1	$(-1/2+1)Fb^2/EJ$	Xb/EJ	
FC b	$-1+x/b$	$Fb-1/2Fx-1/2qx^2$	0	$-Fb+3/2Fx-1/2qx^3/b$	0	$1-2x/b+x^2/b^2$	$(-3/8+0)Fb^2/EJ$	$1/3Xb/EJ$	
CF b	x/b	$-3/2Fx+1/2qx^2$	0	$-3/2Fx^2/b+1/2qx^3/b$	0	x^2/b^2	$(-3/8+0)Fb^2/EJ$	$1/3Xb/EJ$	
totali									
							$1/6Fb^2/EJ$	$5/3Xb/EJ$	
								$-1/10Fb$	

Sviluppi di calcolo iperstatica

$$L_{DE}^{xx} = \int_0^b (x^2/b^2) 1/EJ dx = [1/3 x^3/b^2]_0^b 1/EJ$$

$$= (1/3 b) 1/EJ = 1/3 b/EJ$$

$$L_{ED}^{xx} = \int_0^b (1 - 2x/b + x^2/b^2) 1/EJ dx = [x - x^2/b + 1/3 x^3/b^2]_0^b 1/EJ$$

$$= (b - b + 1/3 b) 1/EJ = 1/3 b/EJ$$

$$L_{EF}^{xx} = \int_0^b (1) 1/EJ dx = [x]_0^b 1/EJ$$

$$= (b) 1/EJ = b/EJ$$

$$L_{FE}^{xx} = \int_0^b (1) 1/EJ dx = [x]_0^b 1/EJ$$

$$= (b) 1/EJ = b/EJ$$

$$L_{FC}^{xx} = \int_0^b (1 - 2x/b + x^2/b^2) 1/EJ dx = [x - x^2/b + 1/3 x^3/b^2]_0^b 1/EJ$$

$$= (b - b + 1/3 b) 1/EJ = 1/3 b/EJ$$

$$L_{CF}^{xx} = \int_0^b (x^2/b^2) 1/EJ dx = [1/3 x^3/b^2]_0^b 1/EJ$$

$$= (1/3 b) 1/EJ = 1/3 b/EJ$$

$$L_{DE}^{xo} = \int_0^b (1/2 x^2/b^2 - 1/2 x^3/b^3) Fb 1/EJ dx = [1/6 x^3/b^2 - 1/8 x^4/b^3]_0^b Fb 1/EJ$$

$$= (1/6 b - 1/8 b) Fb 1/EJ = 1/24 Fb^2/EJ$$

$$L_{ED}^{xo} = \int_0^b (1/2 x/b - x^2/b^2 + 1/2 x^3/b^3) Fb 1/EJ dx = [1/4 x^2/b - 1/3 x^3/b^2 + 1/8 x^4/b^3]_0^b Fb 1/EJ$$

$$= (1/4 b - 1/3 b + 1/8 b) Fb 1/EJ = 1/24 Fb^2/EJ$$

$$L_{EF}^{xo} = \int_0^b (-x/b) Fb 1/EJ dx + \int_0^b (1) \theta dx = [-1/2 x^2/b]_0^b Fb 1/EJ + [x]_0^b \theta$$

$$= (-1/2 b) Fb 1/EJ + (b) \theta = 1/2 Fb^2/EJ$$

$$L_{FE}^{xo} = \int_0^b (-1 + x/b) Fb 1/EJ dx + \int_0^b (-1) \theta dx = [-x + 1/2 x^2/b]_0^b Fb 1/EJ + [-x]_0^b \theta$$

$$= (-b + 1/2 b) Fb 1/EJ + (-b) \theta = 1/2 Fb^2/EJ$$

$$L_{FC}^{xo} = \int_0^b (-1 + 3/2 x/b - 1/2 x^3/b^3) Fb 1/EJ dx = [-x + 3/4 x^2/b - 1/8 x^4/b^3]_0^b Fb 1/EJ$$

$$= (-b + 3/4 b - 1/8 b) Fb 1/EJ = -3/8 Fb^2/EJ$$

$$L_{CF}^{xo} = \int_0^b (-3/2 x^2/b^2 + 1/2 x^3/b^3) Fb 1/EJ dx = [-1/2 x^3/b^2 + 1/8 x^4/b^3]_0^b Fb 1/EJ$$

$$= (-1/2 b + 1/8 b) Fb 1/EJ = -3/8 Fb^2/EJ$$

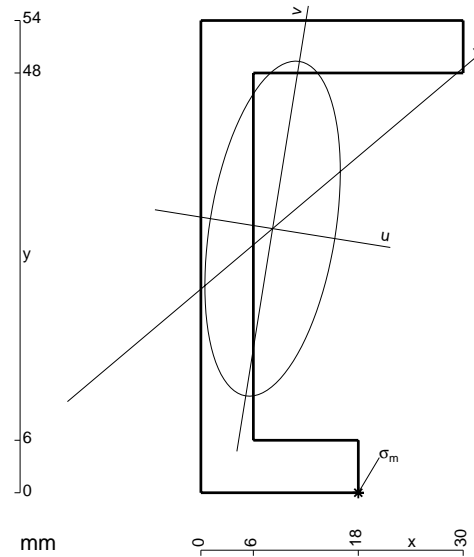

- A = 540. mm²
- J_x = 198266. mm⁴
- J_y = 32378. mm⁴
- J_{xy} = 27302. mm⁴
- J_u = 202644. mm⁴
- J_v = 28000. mm⁴
- α = arctg(2J_{xy}/(J_y-J_x))/2 = -.1590
- c = cosα = .9874
- s = sinα = -.1583
- x_g = 8.2 mm
- y_g = 30.2 mm
- N = -828. N
- T_y = 1380. N
- M_x = 1092960. Nmm
- x_m = 18. mm
- u_m = 14.46 mm
- v_m = -28.27 mm
- σ_m = N/A - Mcv/J_u - Msu/J_v = 238.4 N/mm²

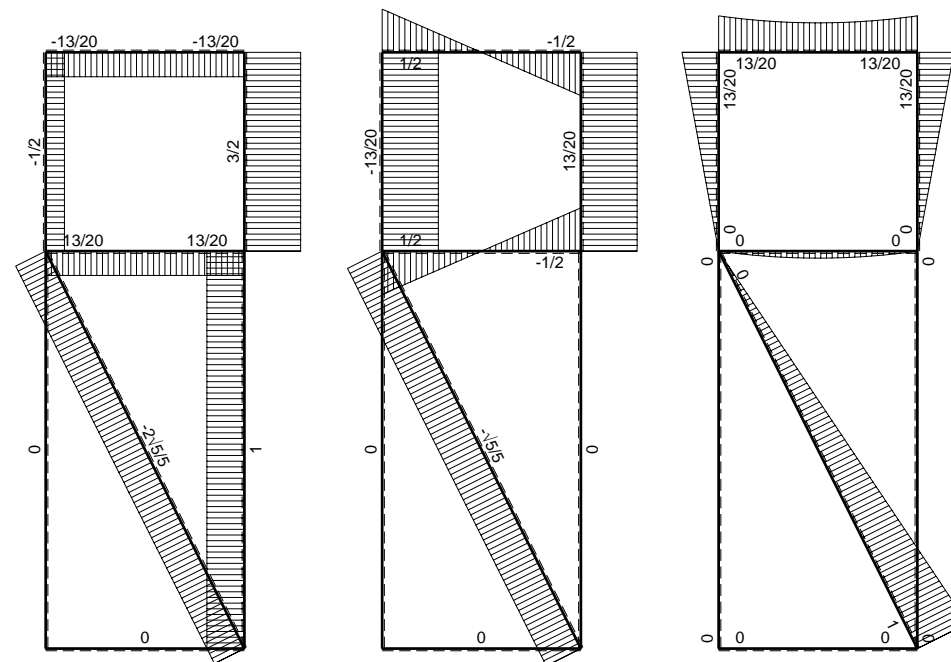
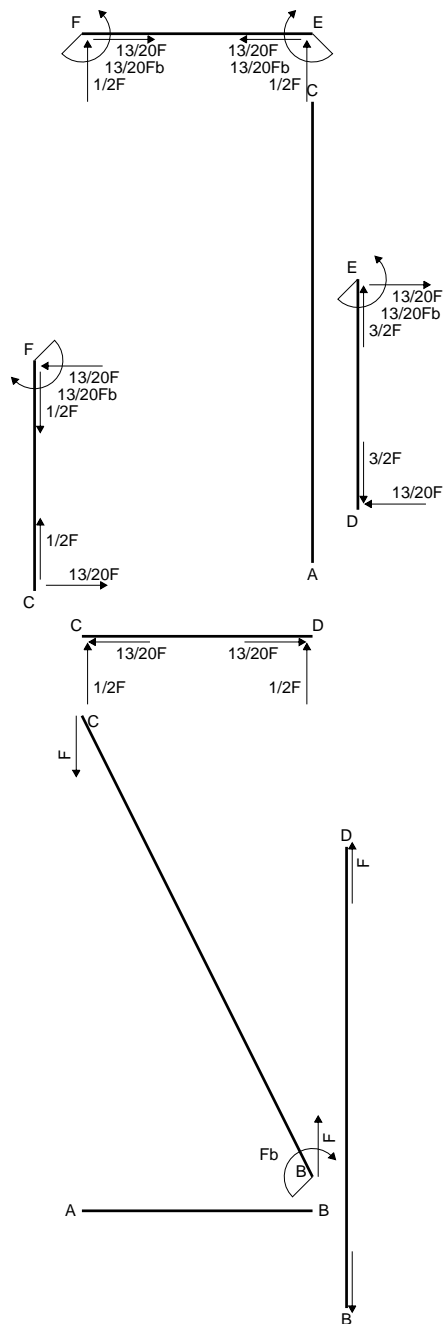

← ⊕ → F

↑ ⊕ ↓ F

⊕ ⊖ F_b

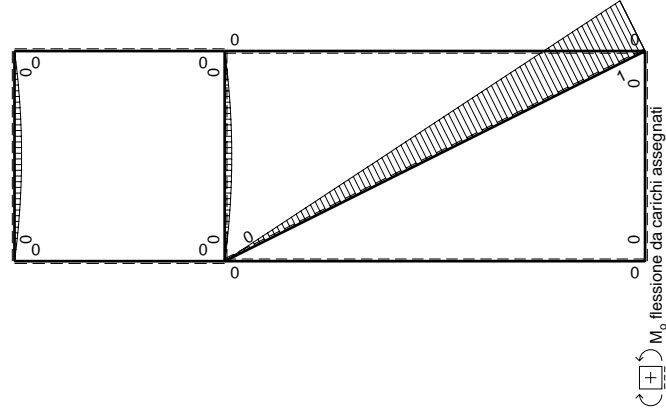
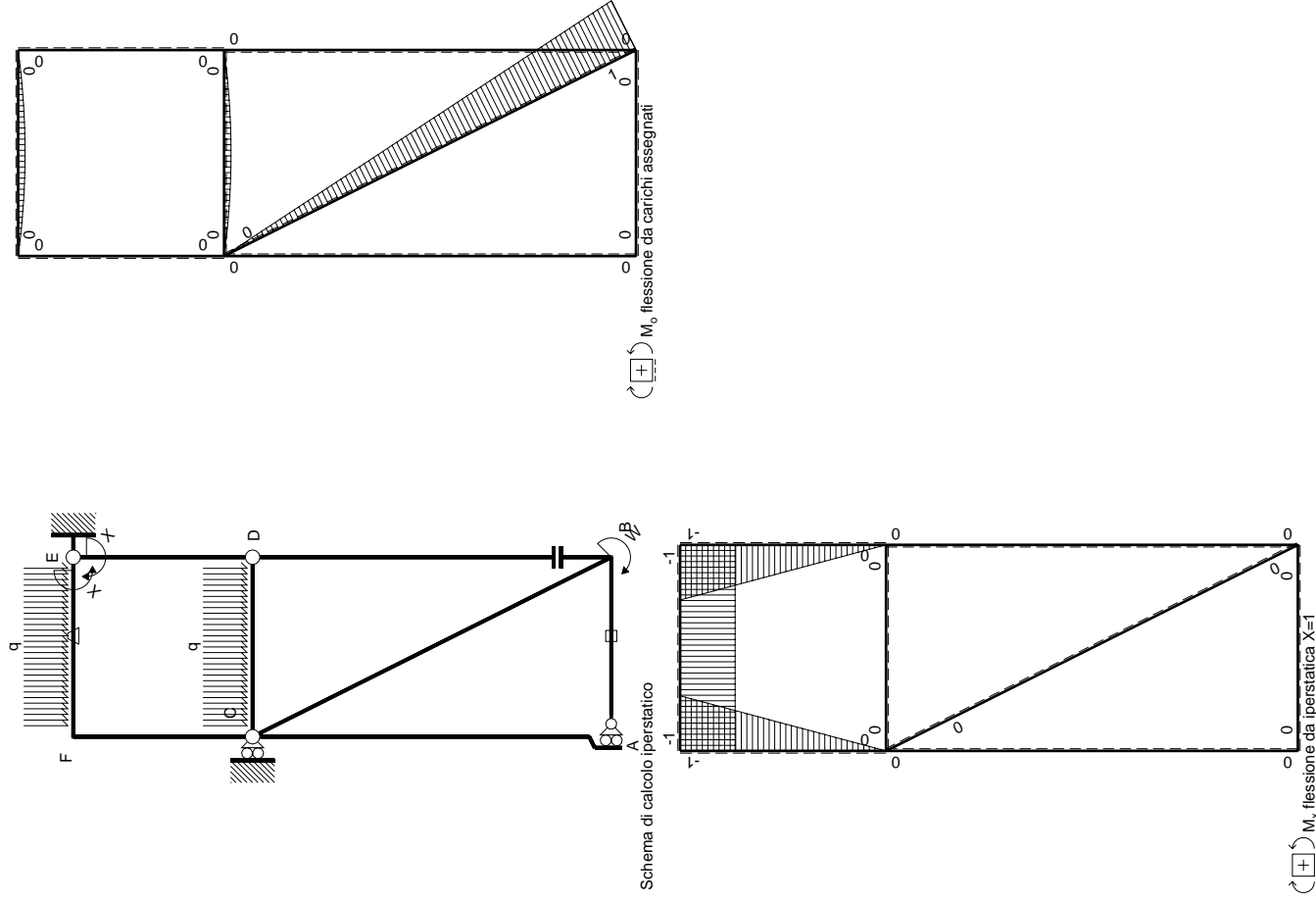

Quadro contributi PLV per iperstatica X=W_{EF}

←	$M^x(x)$	$M^0(x)$	θ	$M^x M^0$	$M^x \theta$	$M^x M_x$	$\int M^x (M^0/EJ + \theta) dx$	$\int M^x M_x / Edx$
AB b	0	0	0	0	0	0	0+0	0
BA b	0	0	0	0	0	0	0	0
BC $\sqrt{5}b$	0	$Fb - \sqrt{5}/5Fx$	0	0	0	0	0	0
AC 2b	0	0	0	0	0	0	0+0	0
DB 2b	0	0	0	0	0	0	0+0	0
BD 2b	0	0	0	0	0	0	0+0	0
DE b	-x/b	0	0	0	0	0	0+0	1/3Xb/EJ
ED b	1-x/b	0	0	0	0	0	0+0	1/3Xb/EJ
CD b	0	$1/2Fx - 1/2qx^2$	0	0	0	0	0+0	0
DC b	0	$-1/2Fx + 1/2qx^2$	0	0	0	0	0+0	0
EF b	-1	$-1/2Fx + 1/2qx^2$	$-Fb/EJ$	$1/2Fx - 1/2Fx^2/b$	Fb/EJ	1	$(1/12 + 1)Fb^2/EJ$	Xb/EJ
FE b	1	$1/2Fx - 1/2qx^2$	Fb/EJ	$1/2Fx - 1/2Fx^2/b$	Fb/EJ	1	$(1/12 + 1)Fb^2/EJ$	Xb/EJ
FC b	-1+x/b	0	0	0	0	0	0+0	1/3Xb/EJ
CF b	x/b	0	0	0	0	0	0+0	1/3Xb/EJ
totali							$13/12 Fb^2/EJ$	$5/3 Xb/EJ$
iperstatica X=W _{EF}							$-13/20 Fb$	

Svilupi di calcolo iperstatica

$$L_{DE}^{xx} = \int_0^b (x^2/b^2) 1/EJ dx = [1/3 x^3/b^2]_0^b 1/EJ$$

$$= (1/3 b) 1/EJ = 1/3 b/EJ$$

$$L_{ED}^{xx} = \int_0^b (1 - 2x/b + x^2/b^2) 1/EJ dx = [x - x^2/b + 1/3 x^3/b^2]_0^b 1/EJ$$

$$= (b - b + 1/3 b) 1/EJ = 1/3 b/EJ$$

$$L_{EF}^{xx} = \int_0^b (1) 1/EJ dx = [x]_0^b 1/EJ$$

$$= (b) 1/EJ = b/EJ$$

$$L_{FE}^{xx} = \int_0^b (1) 1/EJ dx = [x]_0^b 1/EJ$$

$$= (b) 1/EJ = b/EJ$$

$$L_{FC}^{xx} = \int_0^b (1 - 2x/b + x^2/b^2) 1/EJ dx = [x - x^2/b + 1/3 x^3/b^2]_0^b 1/EJ$$

$$= (b - b + 1/3 b) 1/EJ = 1/3 b/EJ$$

$$L_{CF}^{xx} = \int_0^b (x^2/b^2) 1/EJ dx = [1/3 x^3/b^2]_0^b 1/EJ$$

$$= (1/3 b) 1/EJ = 1/3 b/EJ$$

$$L_{EF}^{xo} = \int_0^b (1/2 x/b - 1/2 x^2/b^2) Fb 1/EJ dx + \int_0^b (1) \theta dx = [1/4 x^2/b - 1/6 x^3/b^2]_0^b Fb 1/EJ + [x]_0^b \theta$$

$$= (1/4 b - 1/6 b) Fb 1/EJ + (b) \theta = 13/12 Fb^2/EJ$$

$$L_{FE}^{xo} = \int_0^b (1/2 x/b - 1/2 x^2/b^2) Fb 1/EJ dx + \int_0^b (-1) \theta dx = [1/4 x^2/b - 1/6 x^3/b^2]_0^b Fb 1/EJ + [-x]_0^b \theta$$

$$= (1/4 b - 1/6 b) Fb 1/EJ + (-b) \theta = 13/12 Fb^2/EJ$$

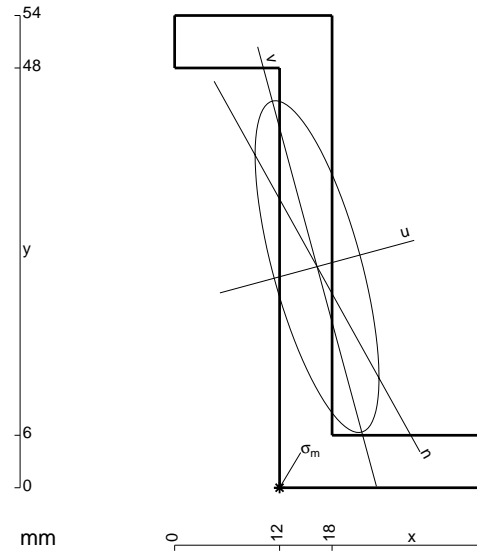

$A = 504. \text{ mm}^2$
 $J_x = 181471. \text{ mm}^4$
 $J_y = 25303. \text{ mm}^4$
 $J_{xy} = -45545. \text{ mm}^4$
 $J_u = 193783. \text{ mm}^4$
 $J_v = 12991. \text{ mm}^4$
 $\alpha = \text{artg}(2J_{xy}/(J_y - J_x))/2 = .2640$
 $c = \cos \alpha = .9653$
 $s = \sin \alpha = .2610$
 $x_g = 16.29 \text{ mm}$
 $y_g = 25.29 \text{ mm}$
 $N = -1431. \text{ N}$
 $T_y = -715.5 \text{ N}$
 $M_x = 608000. \text{ Nmm}$
 $x_m = 12. \text{ mm}$
 $u_m = -10.74 \text{ mm}$
 $v_m = -23.29 \text{ mm}$
 $\sigma_m = N/A - Mcv/J_u - Msu/J_v = 198.8 \text{ N/mm}^2$

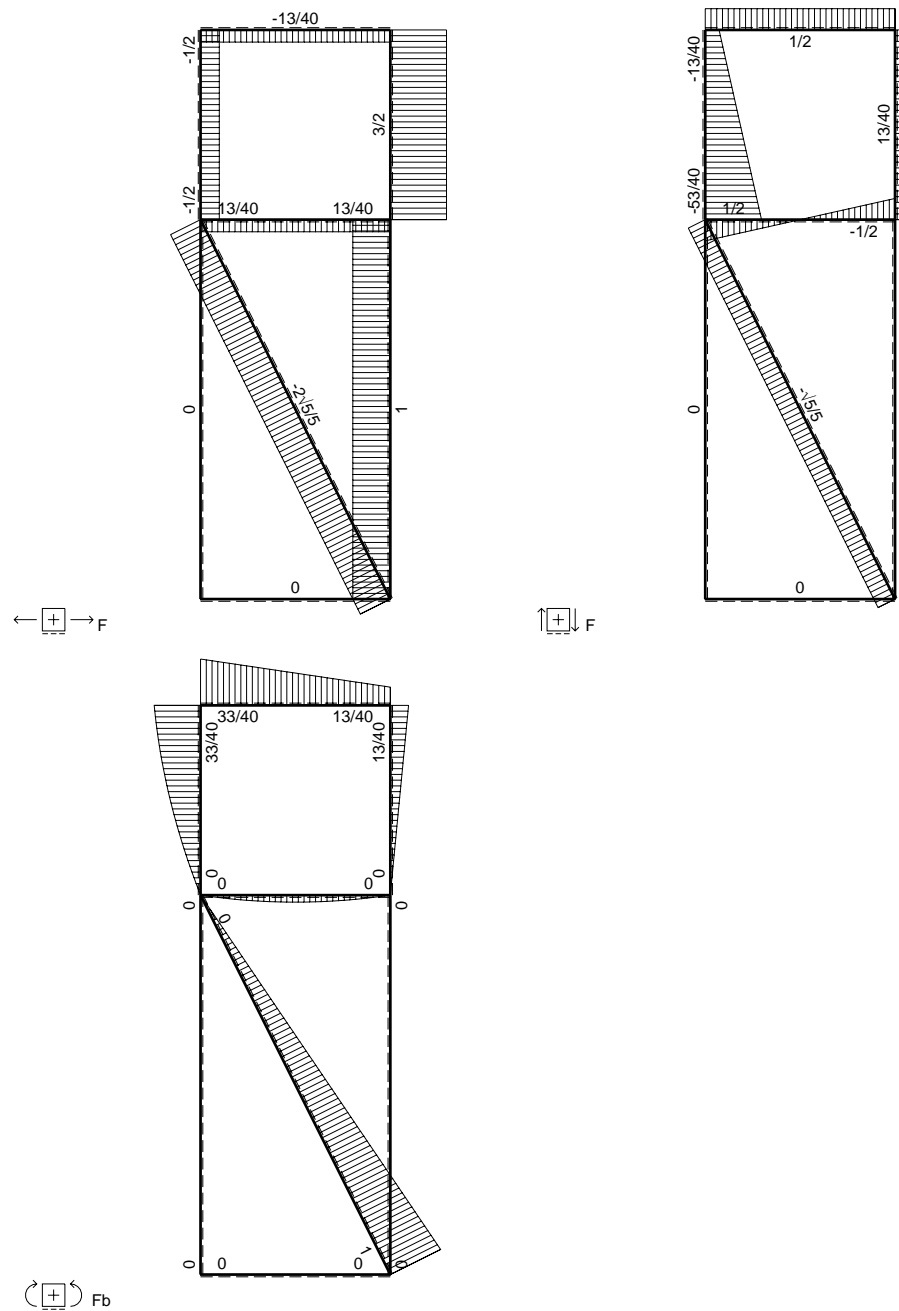
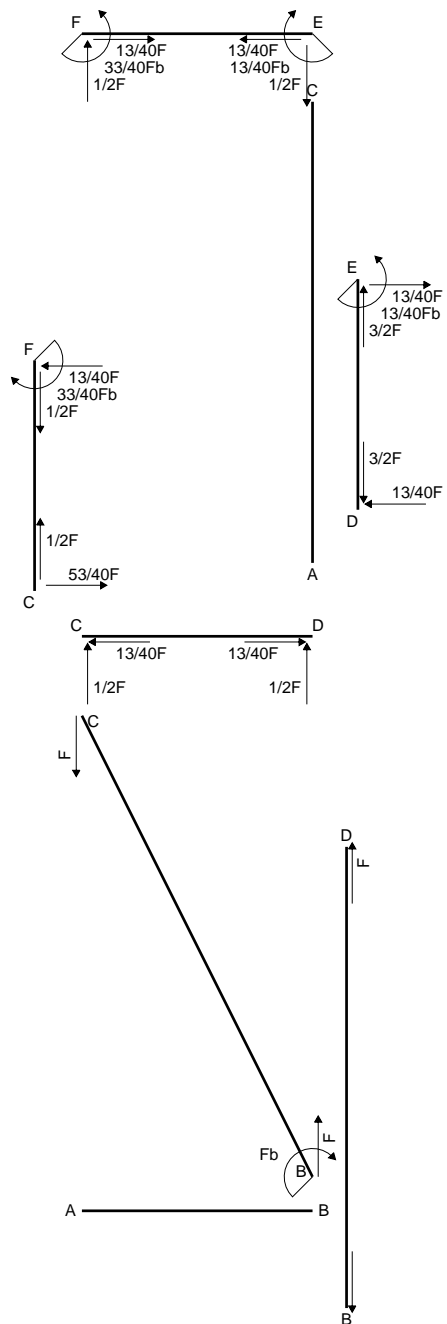

$$L_{DE}^{xx} = \int_0^b (x^2/b^2) 1/EJ dx = [1/3 x^3/b^2]_0^b 1/EJ$$

$$= (1/3 b) 1/EJ = 1/3 b/EJ$$

$$L_{ED}^{xx} = \int_0^b (1 - 2x/b + x^2/b^2) 1/EJ dx = [x - x^2/b + 1/3 x^3/b^2]_0^b 1/EJ$$

$$= (b - b + 1/3 b) 1/EJ = 1/3 b/EJ$$

$$L_{EF}^{xx} = \int_0^b (1) 1/EJ dx = [x]_0^b 1/EJ$$

$$= (b) 1/EJ = b/EJ$$

$$L_{FE}^{xx} = \int_0^b (1) 1/EJ dx = [x]_0^b 1/EJ$$

$$= (b) 1/EJ = b/EJ$$

$$L_{FC}^{xx} = \int_0^b (1 - 2x/b + x^2/b^2) 1/EJ dx = [x - x^2/b + 1/3 x^3/b^2]_0^b 1/EJ$$

$$= (b - b + 1/3 b) 1/EJ = 1/3 b/EJ$$

$$L_{CF}^{xx} = \int_0^b (x^2/b^2) 1/EJ dx = [1/3 x^3/b^2]_0^b 1/EJ$$

$$= (1/3 b) 1/EJ = 1/3 b/EJ$$

$$L_{EF}^{xo} = \int_0^b (-1/2 x/b) Fb 1/EJ dx + \int_0^b (1) \theta dx = [-1/4 x^2/b]_0^b Fb 1/EJ + [x]_0^b \theta$$

$$= (-1/4 b) Fb 1/EJ + (b) \theta = 3/4 Fb^2/EJ$$

$$L_{FE}^{xo} = \int_0^b (-1/2 + 1/2 x/b) Fb 1/EJ dx + \int_0^b (-1) \theta dx = [-1/2 x + 1/4 x^2/b]_0^b Fb 1/EJ + [-x]_0^b \theta$$

$$= (-1/2 b + 1/4 b) Fb 1/EJ + (-b) \theta = 3/4 Fb^2/EJ$$

$$L_{FC}^{xo} = \int_0^b (-1/2 + 1/2 x/b + 1/2 x^2/b^2 - 1/2 x^3/b^3) Fb 1/EJ dx$$

$$= [-1/2 x + 1/4 x^2/b + 1/6 x^3/b^2 - 1/8 x^4/b^3]_0^b Fb 1/EJ$$

$$= (-1/2 b + 1/4 b + 1/6 b - 1/8 b) Fb 1/EJ = -5/24 Fb^2/EJ$$

$$L_{CF}^{xo} = \int_0^b (-x^2/b^2 + 1/2 x^3/b^3) Fb 1/EJ dx = [-1/3 x^3/b^2 + 1/8 x^4/b^3]_0^b Fb 1/EJ$$

$$= (-1/3 b + 1/8 b) Fb 1/EJ = -5/24 Fb^2/EJ$$

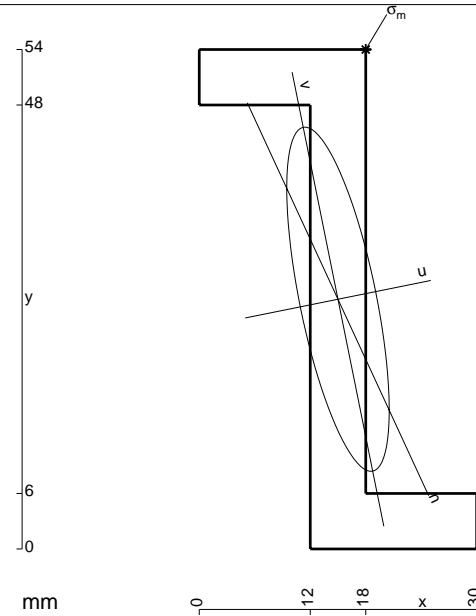

- A = 468. mm²
- J_x = 162108. mm⁴
- J_y = 14364. mm⁴
- J_{xy} = -31104. mm⁴
- J_u = 168389. mm⁴
- J_v = 8083. mm⁴
- α = arctg(2J_{xy}/(J_y-J_x))/2 = .1993
- c = cos α = .9802
- s = sin α = .1979
- x_g = 15. mm
- y_g = 27. mm
- N = -1279. N
- T_y = -639.5 N
- M_x = 586300. Nmm
- x_m = 18. mm
- y_m = 54. mm
- u_m = 8.285 mm
- v_m = 25.87 mm
- σ_m = N/A - Mcv/J_u - Msu/J_v = -210. N/mm²

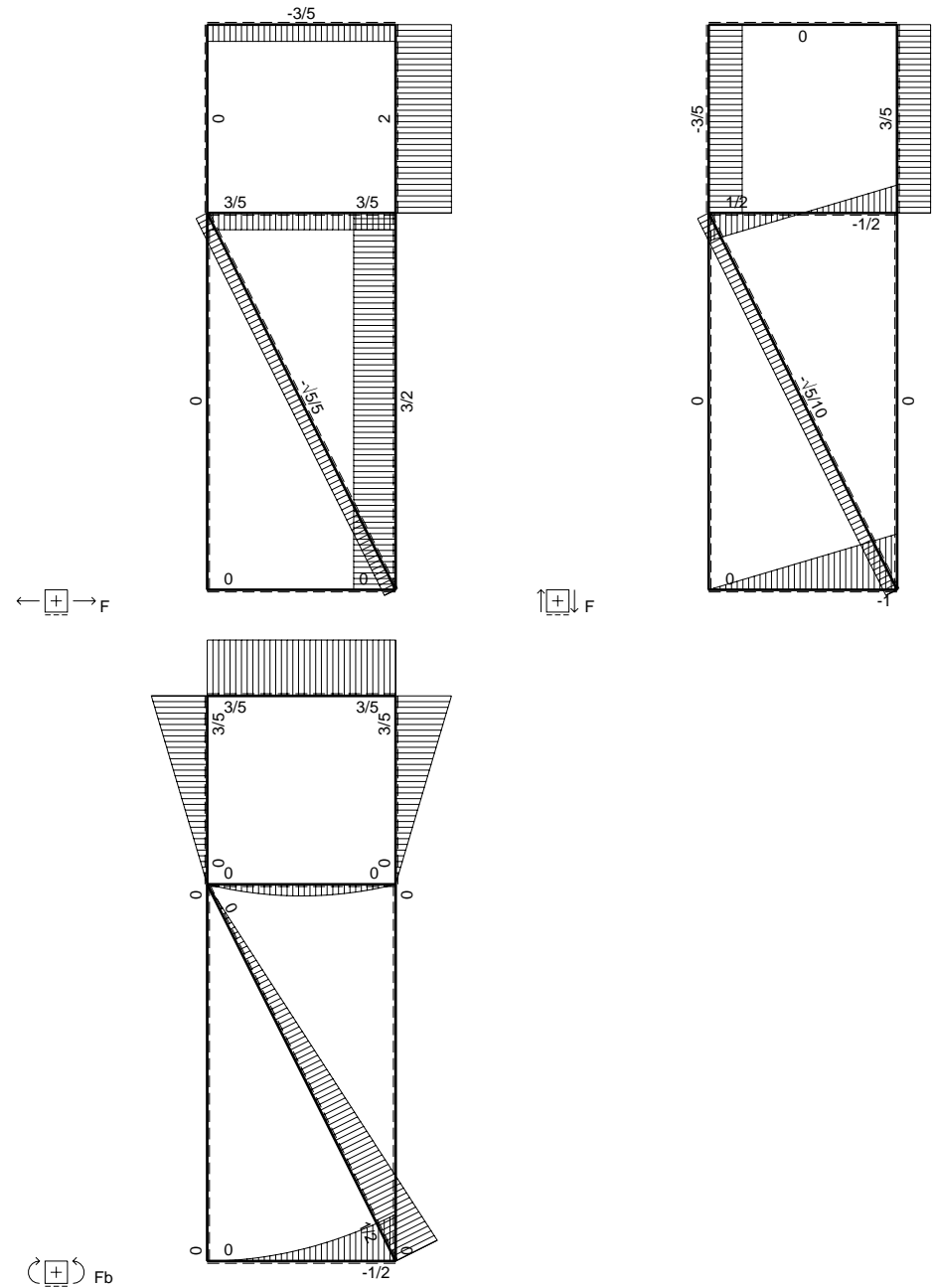
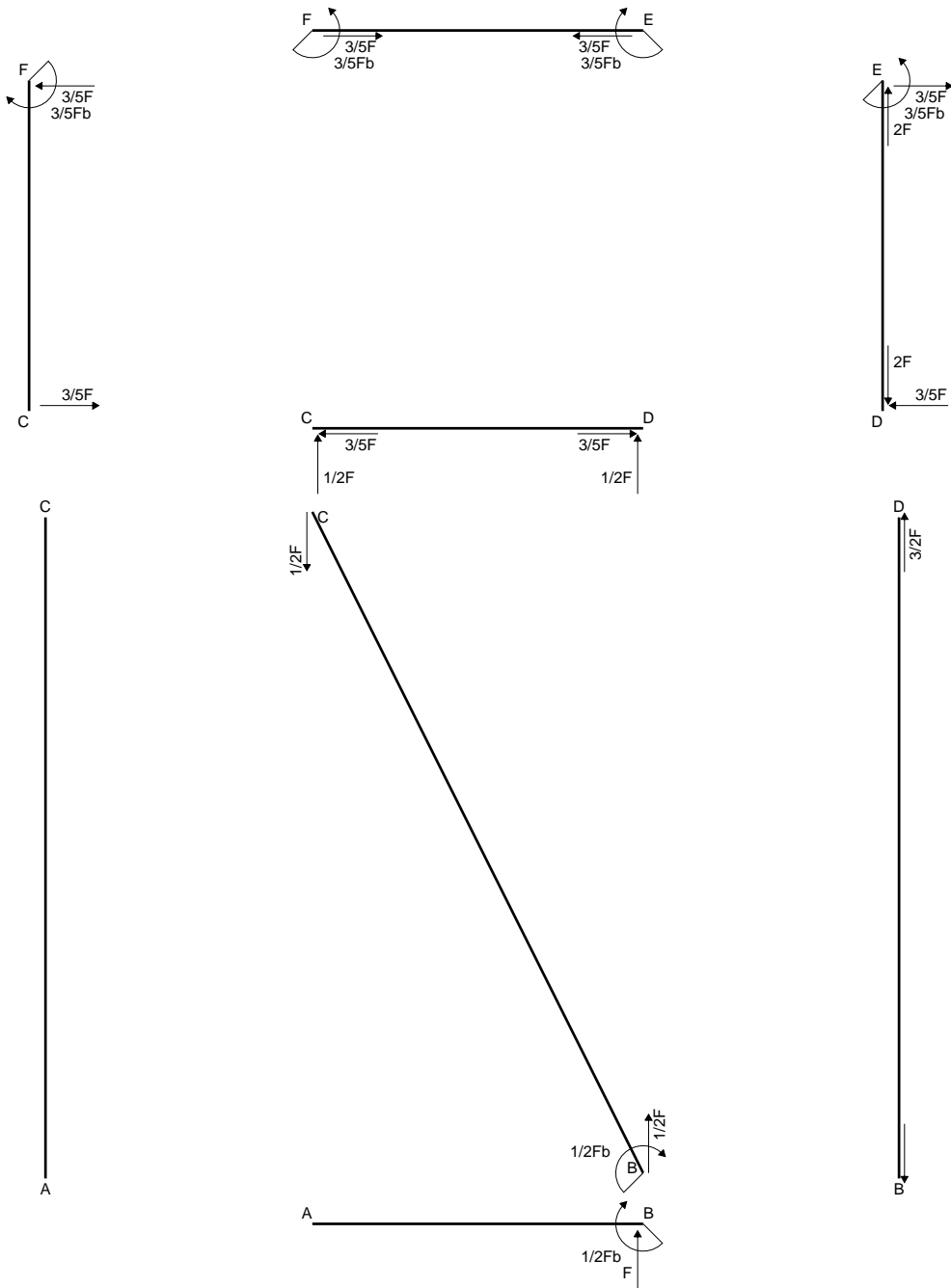

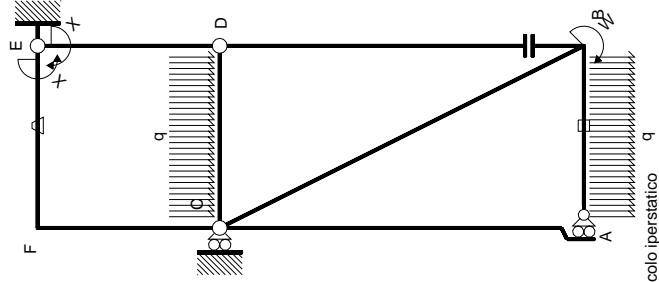

Schema di calcolo iperstatico

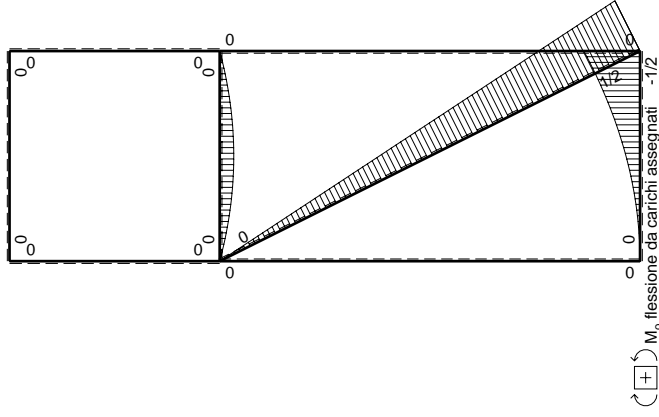

M_0 flessione da carichi assegnati -1/2

Quadro contributi PLV per iperstatica $X=W_{EF}$

\rightarrow	$M_x(x)$	$M_0(x)$	θ	$M_x M_0$	$M_x \theta$	$M_x M_x$	$\int M_x(M_0/EJ+\theta)dx$	$\int X M_x M_x/EJ dx$
AB b	0	$-1/2qx^2$	0	0	0	0	0+0	0
BA b	0	$1/2Fb-Fx+1/2qx^2$	0	0	0	0	0+0	0
BC $\sqrt{5}b$	0	$1/2Fb-\sqrt{5}/10Fx$	0	0	0	0	0	0
AC 2b	0	0	0	0	0	0	0+0	0
CA 2b	0	0	0	0	0	0	0+0	0
DB 2b	0	0	0	0	0	0	0+0	0
BD 2b	0	0	0	0	0	0	0+0	0
DE b	$-x/b$	0	0	0	0	x^2/b^2	0+0	$1/3Xb/EJ$
ED b	$1-x/b$	0	0	0	0	$1-2x/b+x^2/b^2$	0+0	0
CD b	0	$1/2Fx-1/2qx^2$	0	0	0	0	0+0	0
DC b	0	$-1/2Fx+1/2qx^2$	0	0	0	0	0+0	0
EF b	-1	0	$-Fb/EJ$	0	Fb/EJ	1	$(0+1)Fb^2/EJ$	Xb/EJ
FE b	1	0	Fb/EJ	0	Fb/EJ	1		
FC b	$-1+x/b$	0	0	0	0	$1-2x/b+x^2/b^2$	0+0	$1/3Xb/EJ$
CF b	x/b	0	0	0	0	x^2/b^2	Fb^2/EJ	$5/3Xb/EJ$
	totali							
	iperstatica $X=W_{EF}$							
							$-3/5Fb$	

Sviluppi di calcolo iperstatica

M_x flessione da iperstatica $X=1$

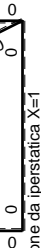

$$L_{DE}^{xx} = \int_0^b (x^2/b^2) 1/EJ dx = [1/3 x^3/b^2]_0^b 1/EJ$$

$$= (1/3 b) 1/EJ = 1/3 b/EJ$$

$$L_{ED}^{xx} = \int_0^b (1 - 2x/b + x^2/b^2) 1/EJ dx = [x - x^2/b + 1/3 x^3/b^2]_0^b 1/EJ$$

$$= (b - b + 1/3 b) 1/EJ = 1/3 b/EJ$$

$$L_{EF}^{xx} = \int_0^b (1) 1/EJ dx = [x]_0^b 1/EJ$$

$$= (b) 1/EJ = b/EJ$$

$$L_{FE}^{xx} = \int_0^b (1) 1/EJ dx = [x]_0^b 1/EJ$$

$$= (b) 1/EJ = b/EJ$$

$$L_{FC}^{xx} = \int_0^b (1 - 2x/b + x^2/b^2) 1/EJ dx = [x - x^2/b + 1/3 x^3/b^2]_0^b 1/EJ$$

$$= (b - b + 1/3 b) 1/EJ = 1/3 b/EJ$$

$$L_{CF}^{xx} = \int_0^b (x^2/b^2) 1/EJ dx = [1/3 x^3/b^2]_0^b 1/EJ$$

$$= (1/3 b) 1/EJ = 1/3 b/EJ$$

$$L_{EF}^{xo} = \int_0^b (1) \theta dx = [x]_0^b \theta$$

$$= (b) \theta = Fb^2/EJ$$

$$L_{FE}^{xo} = \int_0^b (-1) \theta dx = [-x]_0^b \theta$$

$$= (-b) \theta = Fb^2/EJ$$

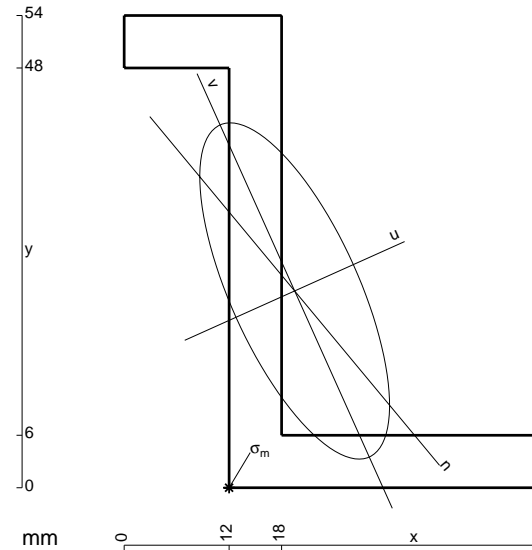

$$A = 576. \text{ mm}^2$$

$$J_x = 212976. \text{ mm}^4$$

$$J_y = 67824. \text{ mm}^4$$

$$J_{xy} = -81648. \text{ mm}^4$$

$$J_u = 249641. \text{ mm}^4$$

$$J_v = 31159. \text{ mm}^4$$

$$\alpha = \text{artg}(2J_{xy}/(J_y - J_x))/2 = .4221$$

$$c = \cos \alpha = .9122$$

$$s = \sin \alpha = .4097$$

$$x_g = 19.5 \text{ mm}$$

$$y_g = 22.5 \text{ mm}$$

$$N = 5660. \text{ N}$$

$$T_y = 1698. \text{ N}$$

$$M_x = 764100. \text{ Nmm}$$

$$x_m = 12. \text{ mm}$$

$$u_m = -16.06 \text{ mm}$$

$$v_m = -17.45 \text{ mm}$$

$$\sigma_m = N/A - Mcv/J_u - Msu/J_v = 219.9 \text{ N/mm}^2$$

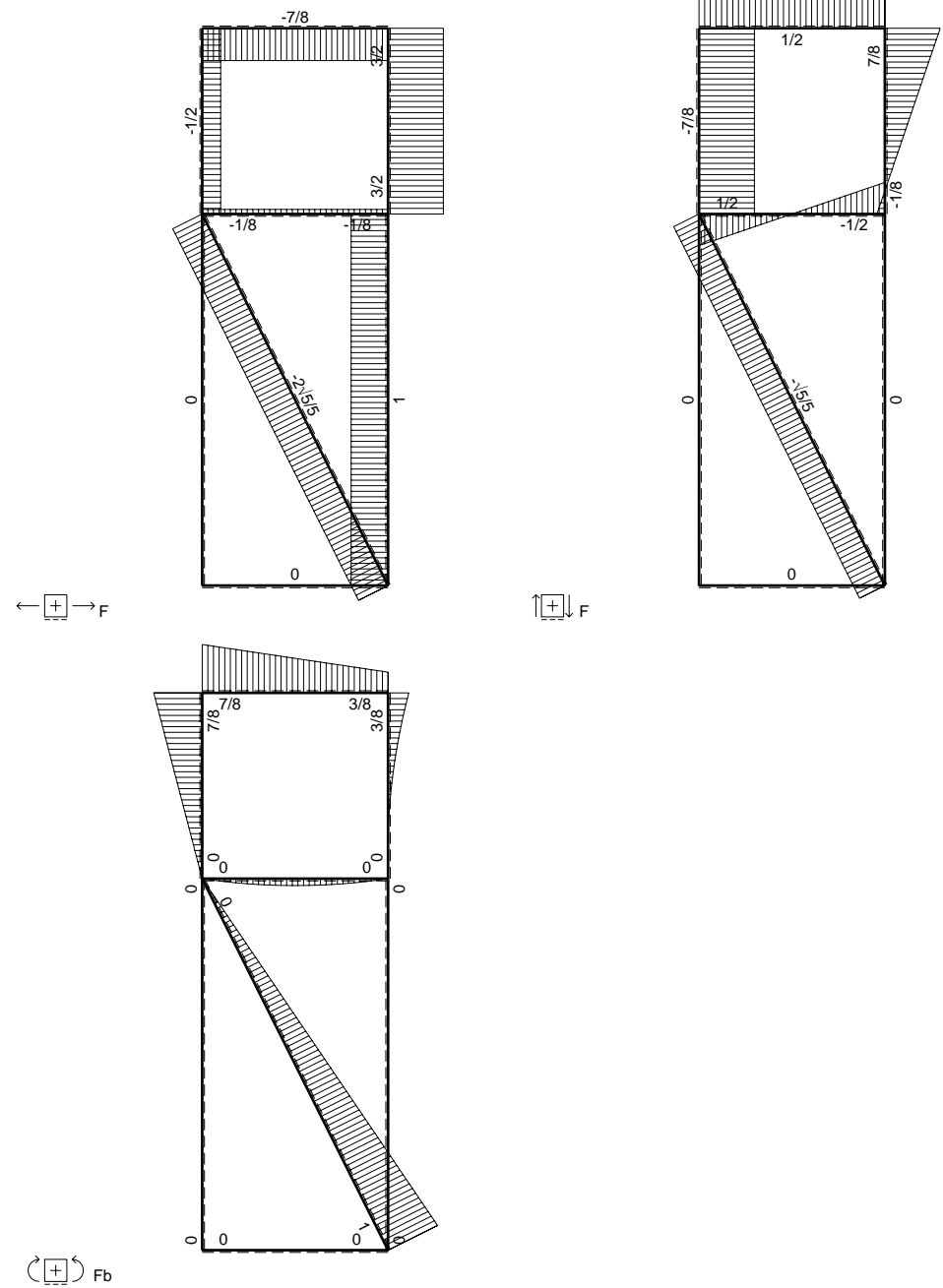
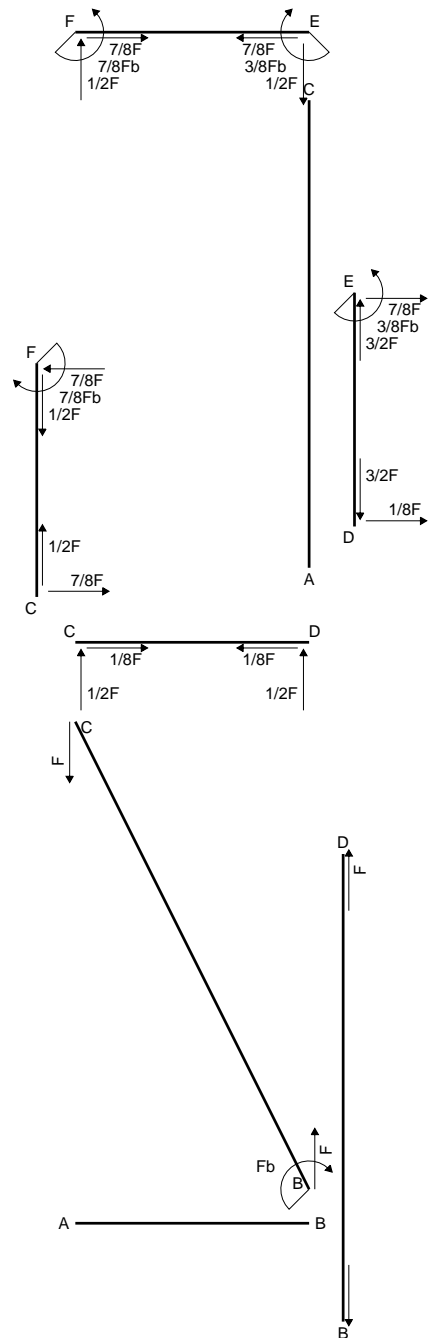

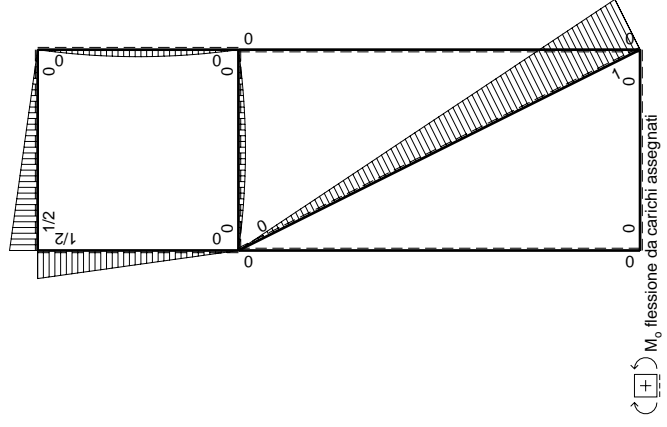
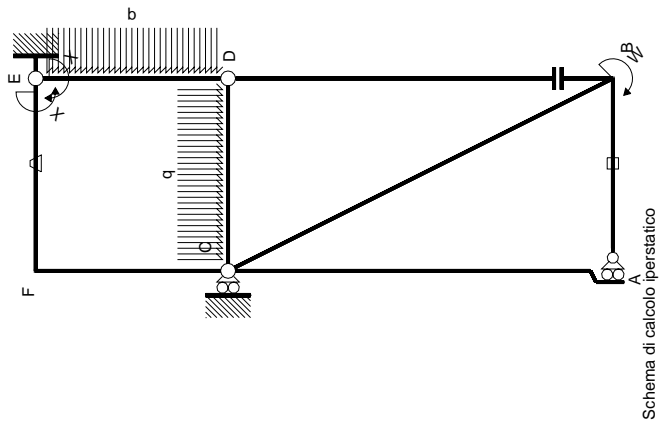

Quadro contributi PLV per iperstatica $X=W_{EF}$

\leftarrow	$M^x(x)$	$M^0(x)$	θ	$M^x M_0$	$M^x \theta$	$M^x M_x$	$\int M^x (M_0/EJ + \theta) dx$	$\int M^x M_x / EJ dx$
AB b	0	0	0	0	0	0	0+0	0
BA b	0	0	0	0	0	0	0	0
BC $\sqrt{5}b$	0	$Fb\sqrt{5}/5Fx$	0	0	0	0	0+0	0
CA 2b	0	0	0	0	0	0	0+0	0
DB 2b	0	0	0	0	0	0	0+0	0
BD 2b	0	0	0	0	0	0	0+0	0
DE b	$-x/b$	$-1/2Fx + 1/2qx^2$	0	$1/2Fx^2/b - 1/2qx^3/b$	0	0	x^2/b^2	$1/3Xb/EJ$
ED b	$1-x/b$	$1/2Fx - 1/2qx^2$	0	$1/2Fx - Fx^2/b + 1/2qx^3/b$	0	0	$1-2x/b+x^2/b^2$	$1/3Xb/EJ$
CD b	0	$1/2Fx - 1/2qx^2$	0	0	0	0	0	0
DC b	0	$-1/2Fx + 1/2qx^2$	0	0	0	0	0+0	0
EF b	-1	$1/2Fx$	$-Fb/EJ$	$-1/2Fx$	Fb/EJ	1	$(-1/4+1)Fb^2/EJ$	Xb/EJ
FE b	1	$-1/2Fb + 1/2Fx$	Fb/EJ	$-1/2Fb + 1/2Fx$	Fb/EJ	1	$(-1/4+1)Fb^2/EJ$	Xb/EJ
FC b	$-1+x/b$	$1/2Fb - 1/2Fx$	0	$-1/2Fb + Fx - 1/2Fx^2/b$	0	0	$1-2x/b+x^2/b^2$	$1/3Xb/EJ$
CF b	x/b	$-1/2Fx$	0	$-1/2Fx^2/b$	0	0	x^2/b^2	$1/3Xb/EJ$
totali								$5/8Fb^2/EJ$
								$-3/8Fb$

Sviluppi di calcolo iperstatica

$$L_{DE}^{xx} = \int_0^b (x^2/b^2) 1/EJ dx = [1/3 x^3/b^2]_0^b 1/EJ$$

$$= (1/3 b) 1/EJ = 1/3 b/EJ$$

$$L_{ED}^{xx} = \int_0^b (1 - 2x/b + x^2/b^2) 1/EJ dx = [x - x^2/b + 1/3 x^3/b^2]_0^b 1/EJ$$

$$= (b - b + 1/3 b) 1/EJ = 1/3 b/EJ$$

$$L_{EF}^{xx} = \int_0^b (1) 1/EJ dx = [x]_0^b 1/EJ$$

$$= (b) 1/EJ = b/EJ$$

$$L_{FE}^{xx} = \int_0^b (1) 1/EJ dx = [x]_0^b 1/EJ$$

$$= (b) 1/EJ = b/EJ$$

$$L_{FC}^{xx} = \int_0^b (1 - 2x/b + x^2/b^2) 1/EJ dx = [x - x^2/b + 1/3 x^3/b^2]_0^b 1/EJ$$

$$= (b - b + 1/3 b) 1/EJ = 1/3 b/EJ$$

$$L_{CF}^{xx} = \int_0^b (x^2/b^2) 1/EJ dx = [1/3 x^3/b^2]_0^b 1/EJ$$

$$= (1/3 b) 1/EJ = 1/3 b/EJ$$

$$L_{DE}^{xo} = \int_0^b (1/2 x^2/b^2 - 1/2 x^3/b^3) Fb 1/EJ dx = [1/6 x^3/b^2 - 1/8 x^4/b^3]_0^b Fb 1/EJ$$

$$= (1/6 b - 1/8 b) Fb 1/EJ = 1/24 Fb^2/EJ$$

$$L_{ED}^{xo} = \int_0^b (1/2 x/b - x^2/b^2 + 1/2 x^3/b^3) Fb 1/EJ dx = [1/4 x^2/b - 1/3 x^3/b^2 + 1/8 x^4/b^3]_0^b Fb 1/EJ$$

$$= (1/4 b - 1/3 b + 1/8 b) Fb 1/EJ = 1/24 Fb^2/EJ$$

$$L_{EF}^{xo} = \int_0^b (-1/2 x/b) Fb 1/EJ dx + \int_0^b (1) \theta dx = [-1/4 x^2/b]_0^b Fb 1/EJ + [x]_0^b \theta$$

$$= (-1/4 b) Fb 1/EJ + (b) \theta = 3/4 Fb^2/EJ$$

$$L_{FE}^{xo} = \int_0^b (-1/2 + 1/2 x/b) Fb 1/EJ dx + \int_0^b (-1) \theta dx = [-1/2 x + 1/4 x^2/b]_0^b Fb 1/EJ + [-x]_0^b \theta$$

$$= (-1/2 b + 1/4 b) Fb 1/EJ + (-b) \theta = 3/4 Fb^2/EJ$$

$$L_{FC}^{xo} = \int_0^b (-1/2 + x/b - 1/2 x^2/b^2) Fb 1/EJ dx = [-1/2 x + 1/2 x^2/b - 1/6 x^3/b^2]_0^b Fb 1/EJ$$

$$= (-1/2 b + 1/2 b - 1/6 b) Fb 1/EJ = -1/6 Fb^2/EJ$$

$$L_{CF}^{xo} = \int_0^b (-1/2 x^2/b^2) Fb 1/EJ dx = [-1/6 x^3/b^2]_0^b Fb 1/EJ$$

$$= (-1/6 b) Fb 1/EJ = -1/6 Fb^2/EJ$$

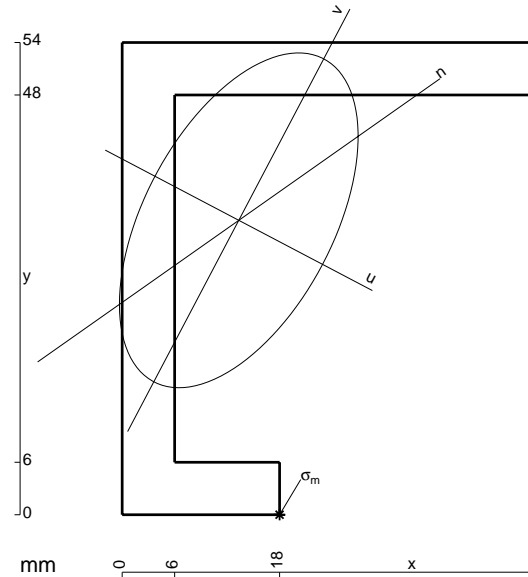

- A = 648. mm²
- J_x = 237528. mm⁴
- J_y = 120672. mm⁴
- J_{xy} = 84960. mm⁴
- J_u = 282212. mm⁴
- J_v = 75988. mm⁴
- α = arctg(2J_{xy}/(J_y-J_x))/2 = -.4842
- c = cos α = .8851
- s = sin α = -.4655
- x_g = 13.33 mm
- y_g = 33.67 mm
- N = -2039. N
- T_y = -1020. N
- M_x = 1117200. Nmm
- x_m = 18. mm
- u_m = 19.8 mm
- v_m = -27.62 mm
- σ_m = N/A - Mcv/J_u - Msu/J_v = 229.2 N/mm²

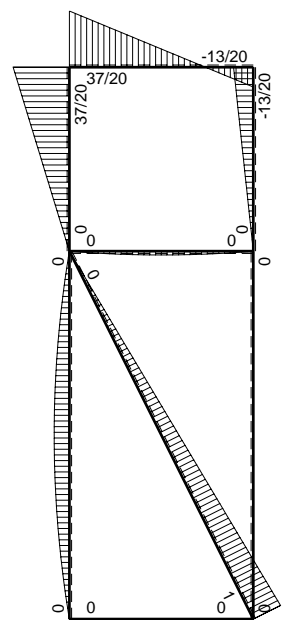
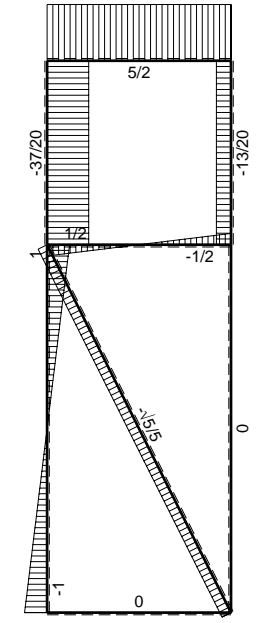
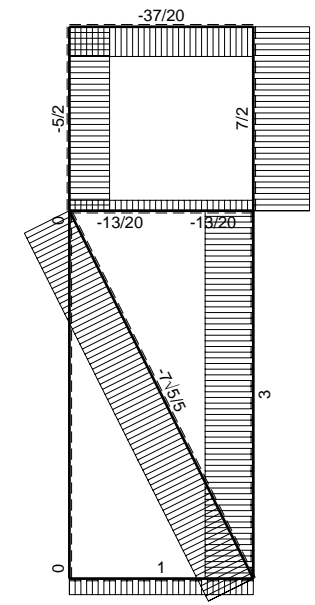
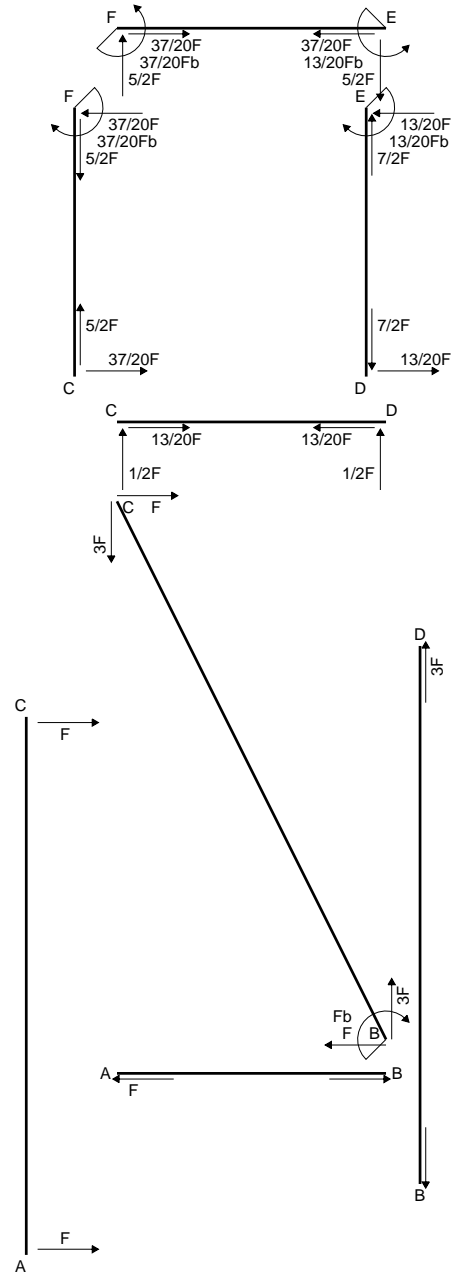

$$L_{DE}^{xx} = \int_0^b (x^2/b^2) 1/EJ dx = [1/3 x^3/b^2]_0^b 1/EJ$$

$$= (1/3 b) 1/EJ = 1/3 b/EJ$$

$$L_{ED}^{xx} = \int_0^b (1 - 2x/b + x^2/b^2) 1/EJ dx = [x - x^2/b + 1/3 x^3/b^2]_0^b 1/EJ$$

$$= (b - b + 1/3 b) 1/EJ = 1/3 b/EJ$$

$$L_{EF}^{xx} = \int_0^b (1) 1/EJ dx = [x]_0^b 1/EJ$$

$$= (b) 1/EJ = b/EJ$$

$$L_{FE}^{xx} = \int_0^b (1) 1/EJ dx = [x]_0^b 1/EJ$$

$$= (b) 1/EJ = b/EJ$$

$$L_{FC}^{xx} = \int_0^b (1 - 2x/b + x^2/b^2) 1/EJ dx = [x - x^2/b + 1/3 x^3/b^2]_0^b 1/EJ$$

$$= (b - b + 1/3 b) 1/EJ = 1/3 b/EJ$$

$$L_{CF}^{xx} = \int_0^b (x^2/b^2) 1/EJ dx = [1/3 x^3/b^2]_0^b 1/EJ$$

$$= (1/3 b) 1/EJ = 1/3 b/EJ$$

$$L_{EF}^{x\theta} = \int_0^b (-5/2 x/b) Fb 1/EJ dx + \int_0^b (1) \theta dx = [-5/4 x^2/b]_0^b Fb 1/EJ + [x]_0^b \theta$$

$$= (-5/4 b) Fb 1/EJ + (b) \theta = -1/4 Fb^2/EJ$$

$$L_{FE}^{x\theta} = \int_0^b (-5/2 + 5/2 x/b) Fb 1/EJ dx + \int_0^b (-1) \theta dx = [-5/2 x + 5/4 x^2/b]_0^b Fb 1/EJ + [-x]_0^b \theta$$

$$= (-5/2 b + 5/4 b) Fb 1/EJ + (-b) \theta = -1/4 Fb^2/EJ$$

$$L_{FC}^{x\theta} = \int_0^b (-5/2 + 5x/b - 5/2 x^2/b^2) Fb 1/EJ dx = [-5/2 x + 5/2 x^2/b - 5/6 x^3/b^2]_0^b Fb 1/EJ$$

$$= (-5/2 b + 5/2 b - 5/6 b) Fb 1/EJ = -5/6 Fb^2/EJ$$

$$L_{CF}^{x\theta} = \int_0^b (-5/2 x^2/b^2) Fb 1/EJ dx = [-5/6 x^3/b^2]_0^b Fb 1/EJ$$

$$= (-5/6 b) Fb 1/EJ = -5/6 Fb^2/EJ$$

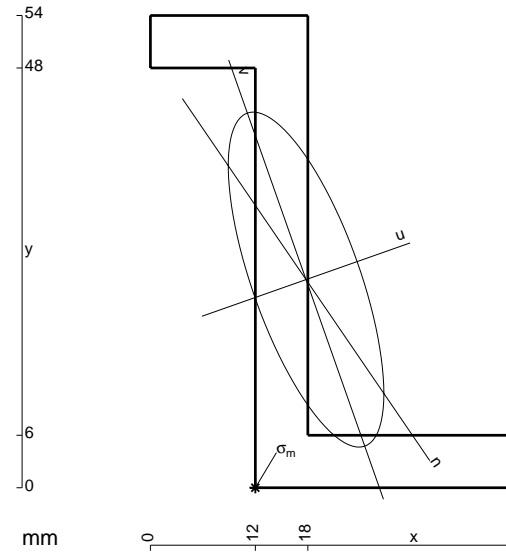

$$A = 540. \text{ mm}^2$$

$$J_x = 198266. \text{ mm}^4$$

$$J_y = 42746. \text{ mm}^4$$

$$J_{xy} = -62554. \text{ mm}^4$$

$$J_u = 220304. \text{ mm}^4$$

$$J_v = 20709. \text{ mm}^4$$

$$\alpha = \text{artg}(2J_{xy}/(J_y - J_x))/2 = .3387$$

$$c = \cos \alpha = .9432$$

$$s = \sin \alpha = .3323$$

$$x_g = 17.8 \text{ mm}$$

$$y_g = 23.8 \text{ mm}$$

$$N = -1499. \text{ N}$$

$$T_y = 2025. \text{ N}$$

$$M_x = 794205. \text{ Nmm}$$

$$x_m = 12. \text{ mm}$$

$$u_m = -13.38 \text{ mm}$$

$$v_m = -20.52 \text{ mm}$$

$$\sigma_m = N/A - Mcv/J_u - Msu/J_v = 237.5 \text{ N/mm}^2$$

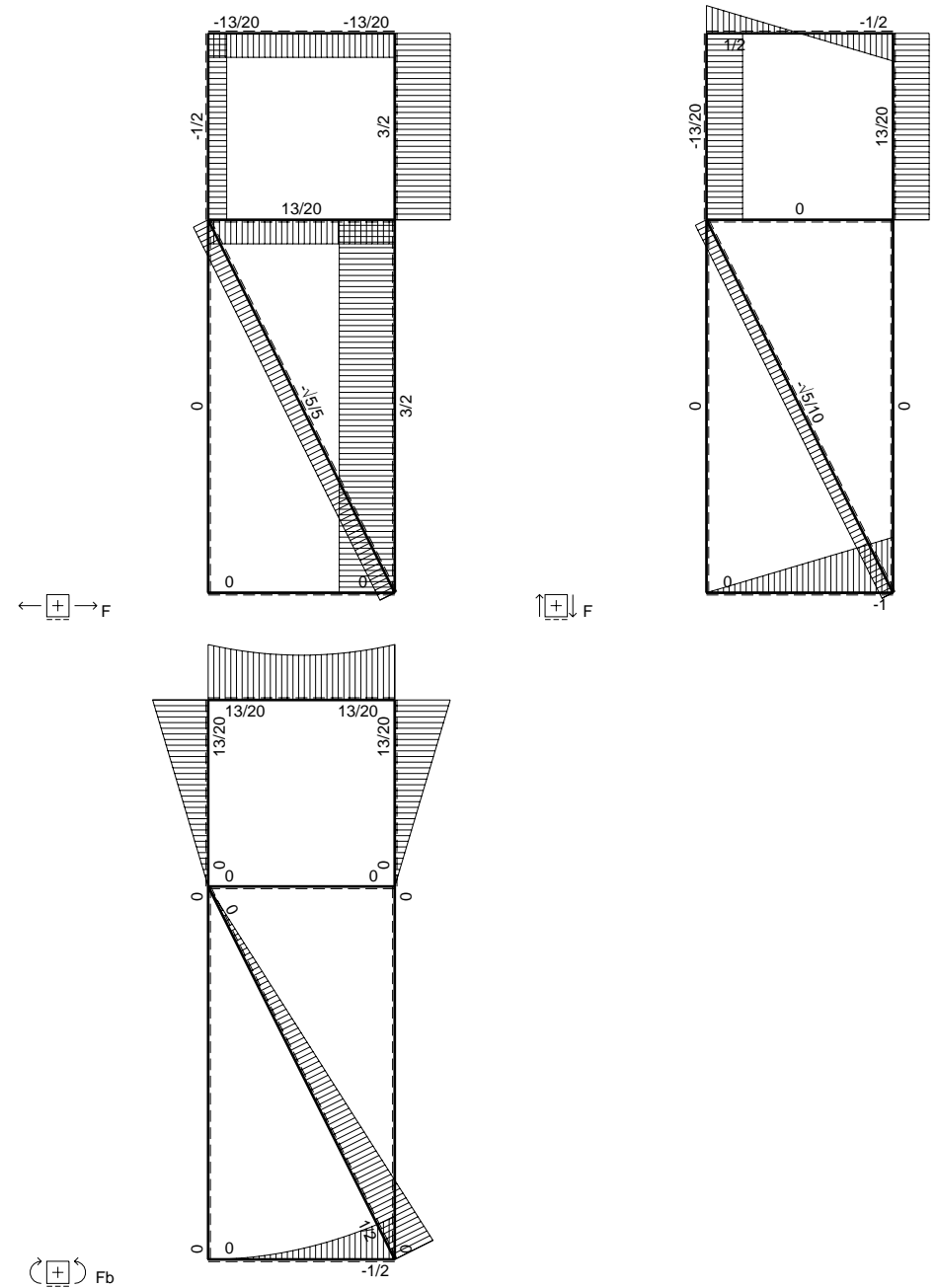
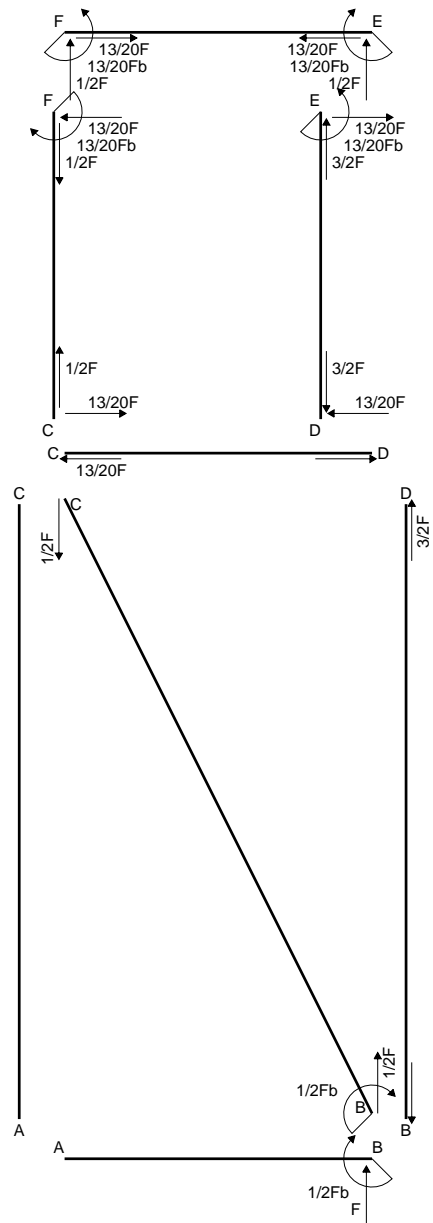

$$L_{DE}^{xx} = \int_0^b (x^2/b^2) 1/EJ dx = [1/3 x^3/b^2]_0^b 1/EJ$$

$$= (1/3 b) 1/EJ = 1/3 b/EJ$$

$$L_{ED}^{xx} = \int_0^b (1 - 2x/b + x^2/b^2) 1/EJ dx = [x - x^2/b + 1/3 x^3/b^2]_0^b 1/EJ$$

$$= (b - b + 1/3 b) 1/EJ = 1/3 b/EJ$$

$$L_{EF}^{xx} = \int_0^b (1) 1/EJ dx = [x]_0^b 1/EJ$$

$$= (b) 1/EJ = b/EJ$$

$$L_{FE}^{xx} = \int_0^b (1) 1/EJ dx = [x]_0^b 1/EJ$$

$$= (b) 1/EJ = b/EJ$$

$$L_{FC}^{xx} = \int_0^b (1 - 2x/b + x^2/b^2) 1/EJ dx = [x - x^2/b + 1/3 x^3/b^2]_0^b 1/EJ$$

$$= (b - b + 1/3 b) 1/EJ = 1/3 b/EJ$$

$$L_{CF}^{xx} = \int_0^b (x^2/b^2) 1/EJ dx = [1/3 x^3/b^2]_0^b 1/EJ$$

$$= (1/3 b) 1/EJ = 1/3 b/EJ$$

$$L_{EF}^{xo} = \int_0^b (1/2 x/b - 1/2 x^2/b^2) Fb 1/EJ dx + \int_0^b (1) \theta dx = [1/4 x^2/b - 1/6 x^3/b^2]_0^b Fb 1/EJ + [x]_0^b \theta$$

$$= (1/4 b - 1/6 b) Fb 1/EJ + (b) \theta = 13/12 Fb^2/EJ$$

$$L_{FE}^{xo} = \int_0^b (1/2 x/b - 1/2 x^2/b^2) Fb 1/EJ dx + \int_0^b (-1) \theta dx = [1/4 x^2/b - 1/6 x^3/b^2]_0^b Fb 1/EJ + [-x]_0^b \theta$$

$$= (1/4 b - 1/6 b) Fb 1/EJ + (-b) \theta = 13/12 Fb^2/EJ$$

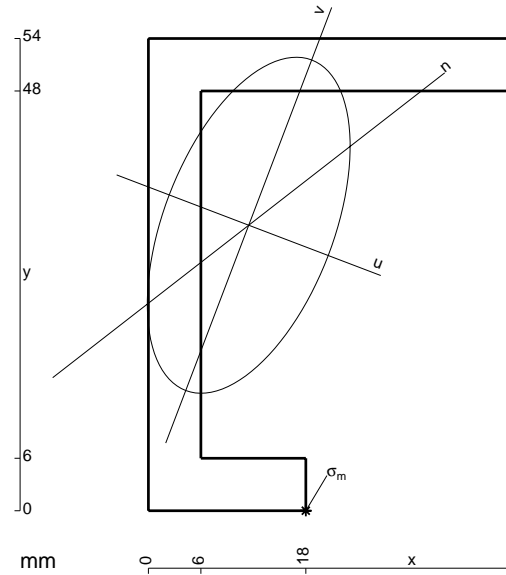

$$A = 612. \text{ mm}^2$$

$$J_x = 225968. \text{ mm}^4$$

$$J_y = 82341. \text{ mm}^4$$

$$J_{xy} = 64038. \text{ mm}^4$$

$$J_u = 250373. \text{ mm}^4$$

$$J_v = 57936. \text{ mm}^4$$

$$\alpha = \text{artg}(2J_{xy}/(J_y - J_x))/2 = -.3641$$

$$c = \cos \alpha = .9344$$

$$s = \sin \alpha = -.3561$$

$$x_g = 11.47 \text{ mm}$$

$$y_g = 32.65 \text{ mm}$$

$$N = 3660. \text{ N}$$

$$T_y = 1586. \text{ N}$$

$$M_x = 904020. \text{ Nmm}$$

$$x_m = 18. \text{ mm}$$

$$u_m = 17.73 \text{ mm}$$

$$v_m = -28.18 \text{ mm}$$

$$\sigma_m = N/A - Mcv/J_u - Msu/J_v = 199.6 \text{ N/mm}^2$$

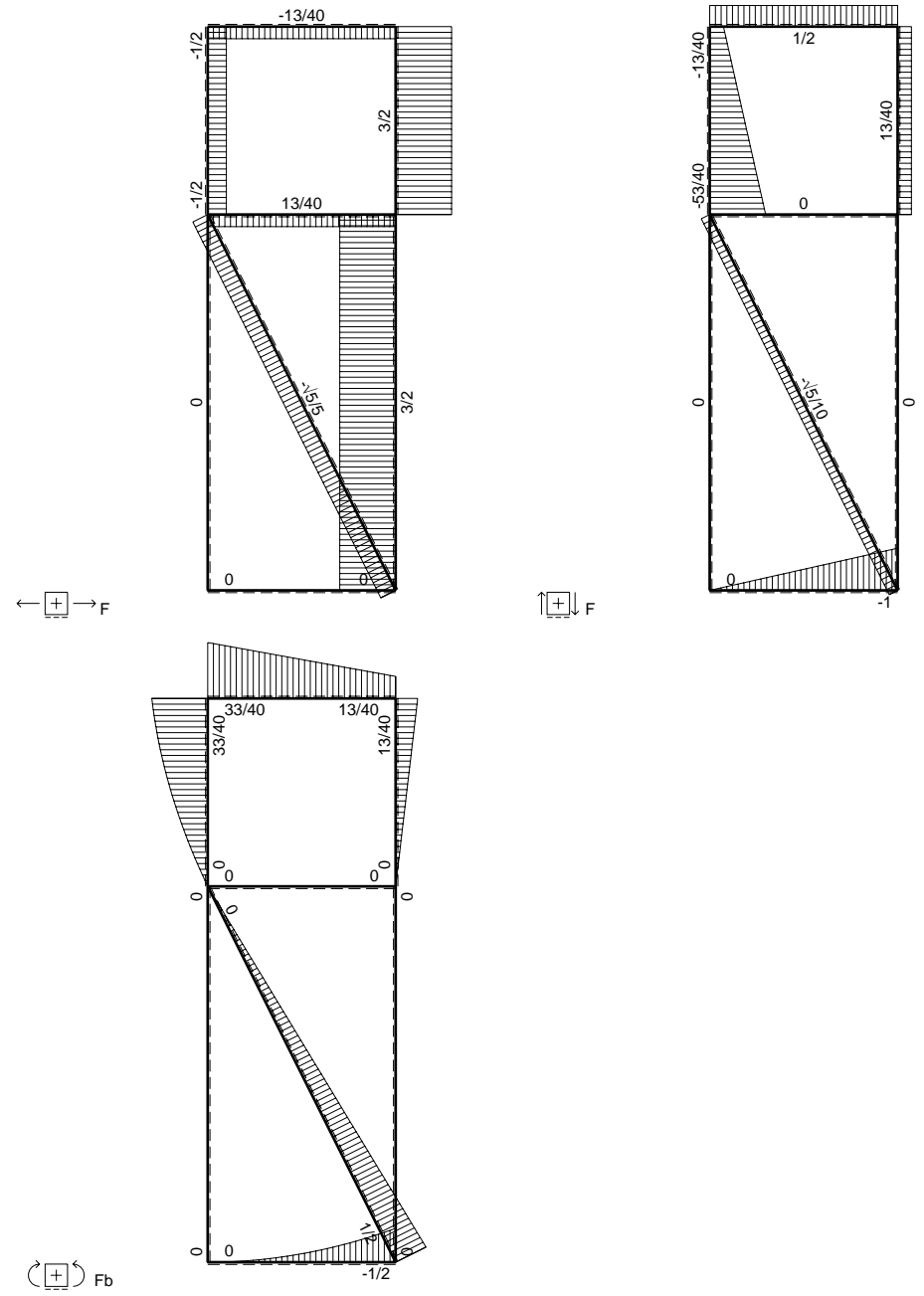
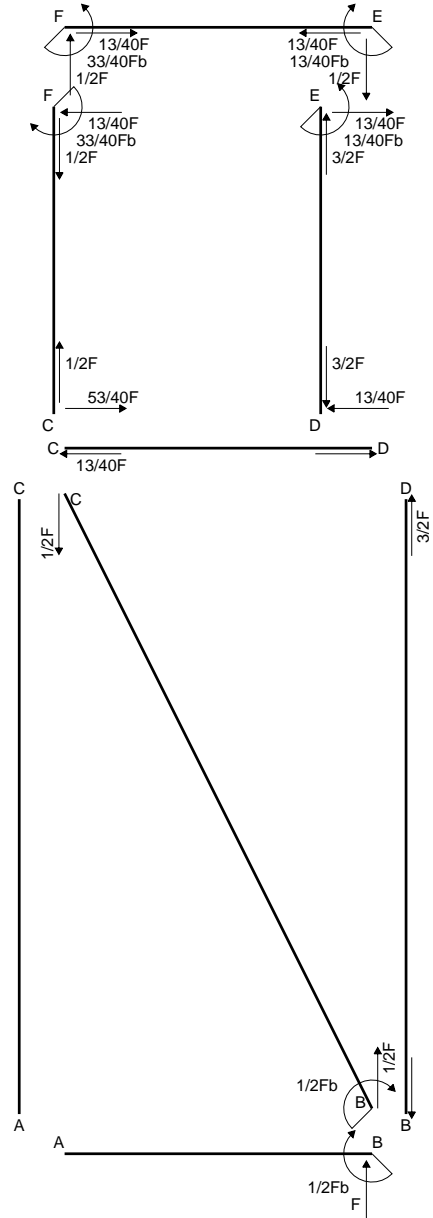

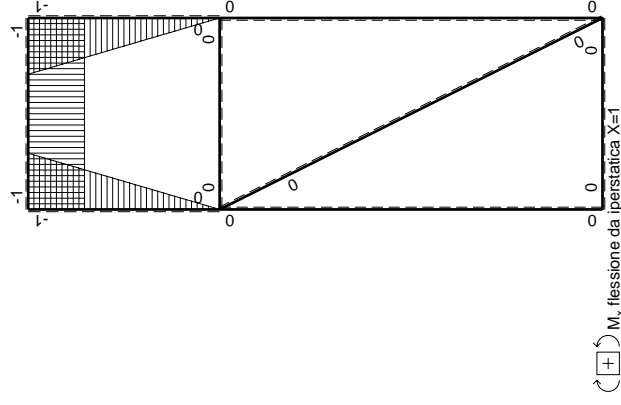
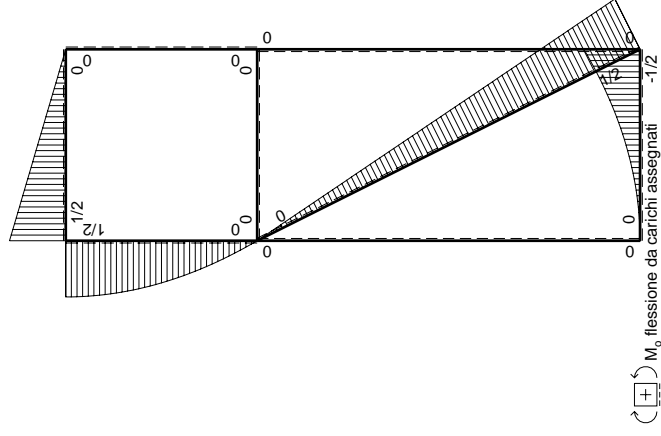
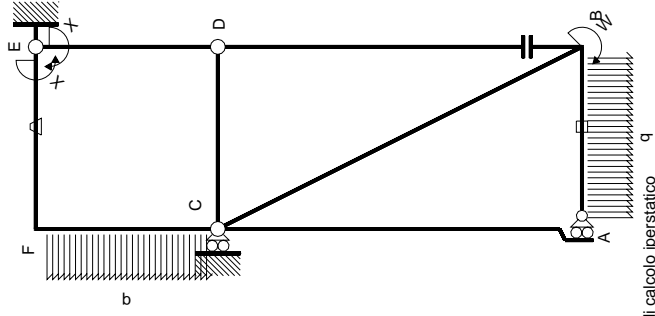

Quadro contributi PLV per iperstatica $X=W_{EF}$

\rightarrow	$M^x(x)$	$M^0(x)$	θ	$M^x M_0$	$M^x \theta$	$M^x M_x$	$\int M^x (M_0/EJ + \theta) dx$	$\int M^x M_x / E dx$
AB b	0	$-1/2qx^2$	0	0	0	0	0	0
BA b	0	$1/2Fb - Fx + 1/2qx^2$	0	0	0	0	0	0
BC $\sqrt{5}b$	0	$1/2Fb - \sqrt{5}/10Fx$	0	0	0	0	0	0
AC 2b	0	0	0	0	0	0	0	0
CA 2b	0	0	0	0	0	0	0	0
DB 2b	0	0	0	0	0	0	0	0
BD 2b	0	0	0	0	0	0	0	0
DE b	-x/b	0	0	0	0	0	0	0
ED b	1-x/b	0	0	0	0	0	0	0
CD b	0	0	0	0	0	0	0	0
DC b	0	0	0	0	0	0	0	0
EF b	-1	$1/2Fx$	-Fb/EJ	-1/2Fx	Fb/EJ	1	$(-1/4+1)Fb^2/EJ$	Xb/EJ
FE b	1	$-1/2Fb+1/2Fx$	Fb/EJ	-1/2Fb+1/2Fx	Fb/EJ	1	$(-1/4+1)Fb^2/EJ$	Xb/EJ
FC b	-1+x/b	$1/2Fb-1/2qx^2$	0	$-1/2Fb+1/2Fx+1/2Fx^2/b-1/2qx^3/b$	0	0	$(-5/24+0)Fb^2/EJ$	$1/3Xb/EJ$
CF b	x/b	$-Fx+1/2qx^2$	0	$-Fx^2/b+1/2qx^3/b$	0	0	$13/24Fb^2/EJ$	$5/3Xb/EJ$
totali								
		iperstatica $X=W_{EF}$						

Sviluppi di calcolo iperstatica

$$L_{DE}^{xx} = \int_0^b (x^2/b^2) 1/EJ dx = [1/3 x^3/b^2]_0^b 1/EJ$$

$$= (1/3 b) 1/EJ = 1/3 b/EJ$$

$$L_{ED}^{xx} = \int_0^b (1 - 2x/b + x^2/b^2) 1/EJ dx = [x - x^2/b + 1/3 x^3/b^2]_0^b 1/EJ$$

$$= (b - b + 1/3 b) 1/EJ = 1/3 b/EJ$$

$$L_{EF}^{xx} = \int_0^b (1) 1/EJ dx = [x]_0^b 1/EJ$$

$$= (b) 1/EJ = b/EJ$$

$$L_{FE}^{xx} = \int_0^b (1) 1/EJ dx = [x]_0^b 1/EJ$$

$$= (b) 1/EJ = b/EJ$$

$$L_{FC}^{xx} = \int_0^b (1 - 2x/b + x^2/b^2) 1/EJ dx = [x - x^2/b + 1/3 x^3/b^2]_0^b 1/EJ$$

$$= (b - b + 1/3 b) 1/EJ = 1/3 b/EJ$$

$$L_{CF}^{xx} = \int_0^b (x^2/b^2) 1/EJ dx = [1/3 x^3/b^2]_0^b 1/EJ$$

$$= (1/3 b) 1/EJ = 1/3 b/EJ$$

$$L_{EF}^{xo} = \int_0^b (-1/2 x/b) Fb 1/EJ dx + \int_0^b (1) \theta dx = [-1/4 x^2/b]_0^b Fb 1/EJ + [x]_0^b \theta$$

$$= (-1/4 b) Fb 1/EJ + (b) \theta = 3/4 Fb^2/EJ$$

$$L_{FE}^{xo} = \int_0^b (-1/2 + 1/2 x/b) Fb 1/EJ dx + \int_0^b (-1) \theta dx = [-1/2 x + 1/4 x^2/b]_0^b Fb 1/EJ + [-x]_0^b \theta$$

$$= (-1/2 b + 1/4 b) Fb 1/EJ + (-b) \theta = 3/4 Fb^2/EJ$$

$$L_{FC}^{xo} = \int_0^b (-1/2 + 1/2 x/b + 1/2 x^2/b^2 - 1/2 x^3/b^3) Fb 1/EJ dx$$

$$= [-1/2 x + 1/4 x^2/b + 1/6 x^3/b^2 - 1/8 x^4/b^3]_0^b Fb 1/EJ$$

$$= (-1/2 b + 1/4 b + 1/6 b - 1/8 b) Fb 1/EJ = -5/24 Fb^2/EJ$$

$$L_{CF}^{xo} = \int_0^b (-x^2/b^2 + 1/2 x^3/b^3) Fb 1/EJ dx = [-1/3 x^3/b^2 + 1/8 x^4/b^3]_0^b Fb 1/EJ$$

$$= (-1/3 b + 1/8 b) Fb 1/EJ = -5/24 Fb^2/EJ$$

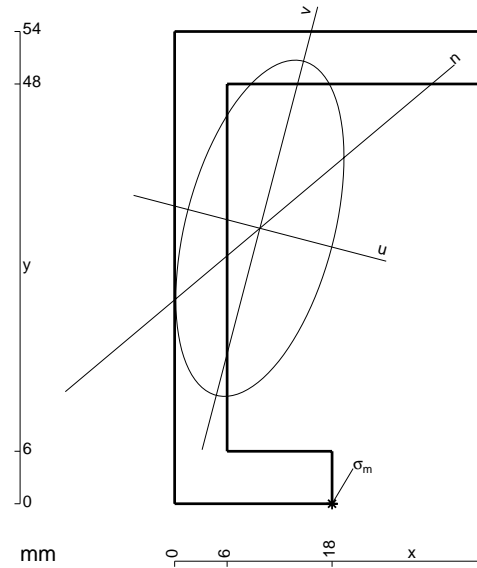

- A = 576. mm²
- J_x = 212976. mm⁴
- J_y = 53244. mm⁴
- J_{xy} = 44712. mm⁴
- J_u = 224640. mm⁴
- J_v = 41580. mm⁴
- α = artg(2J_{xy}/(J_y-J_x))/2 = -.2552
- c = cosα = .9676
- s = sinα = -.2524
- x_g = 9.75 mm
- y_g = 31.5 mm
- N = -630.5 N
- T_y = 970. N
- M_x = 960300. Nmm
- x_m = 18. mm
- u_m = 15.93 mm
- v_m = -28.4 mm
- σ_m = N/A-Mcv/J_u-Msu/J_v = 209.3 N/mm²

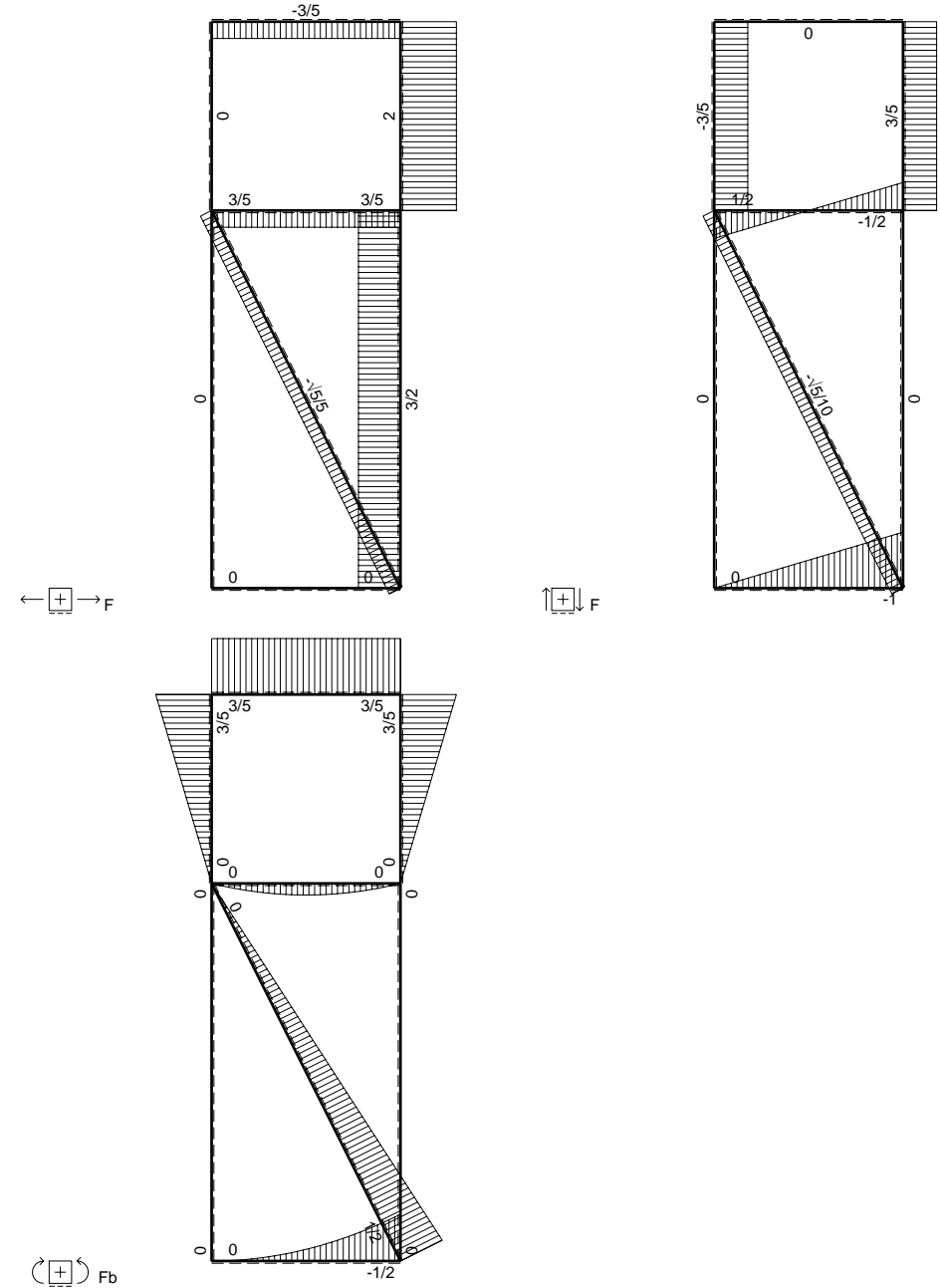
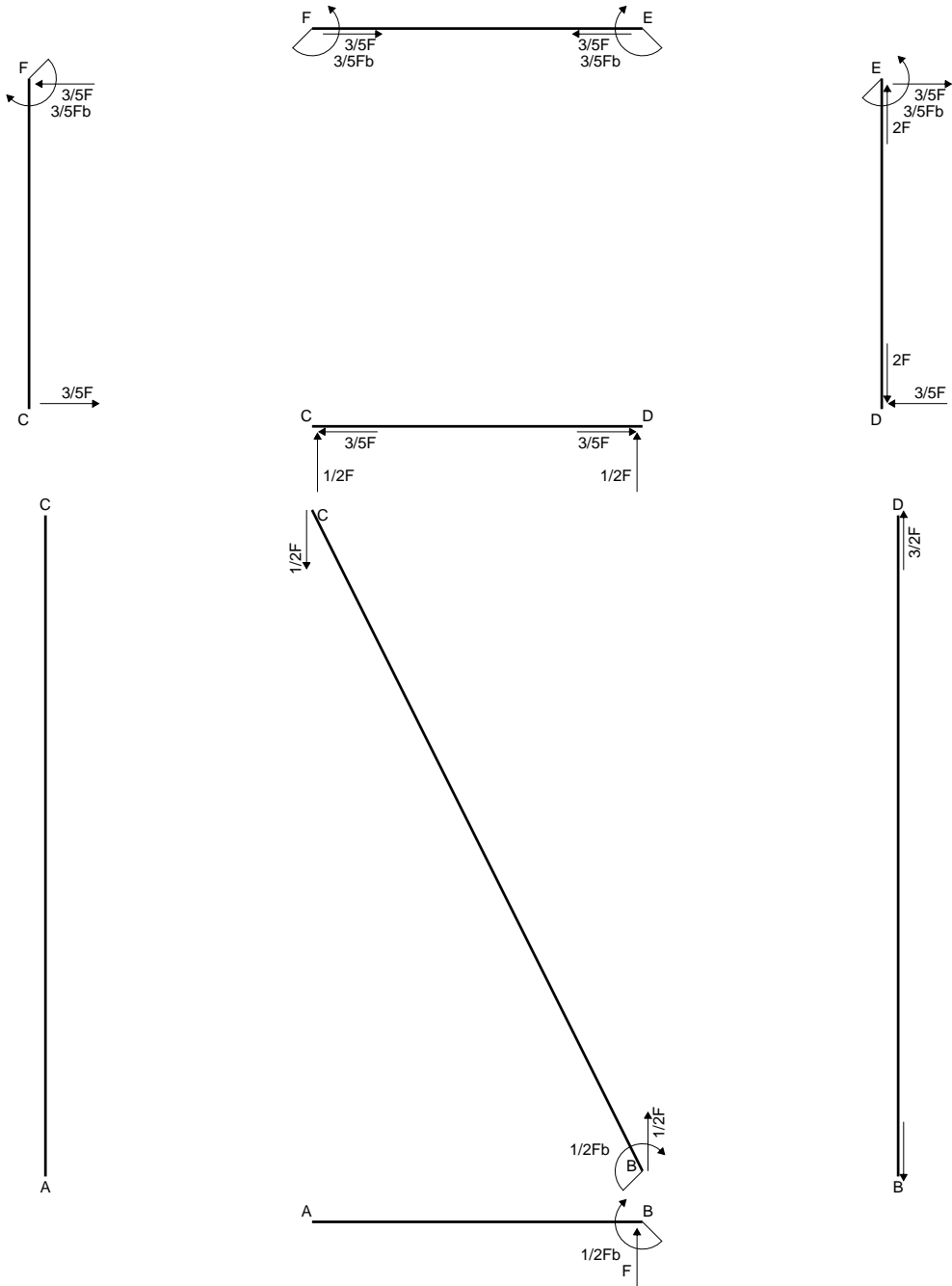

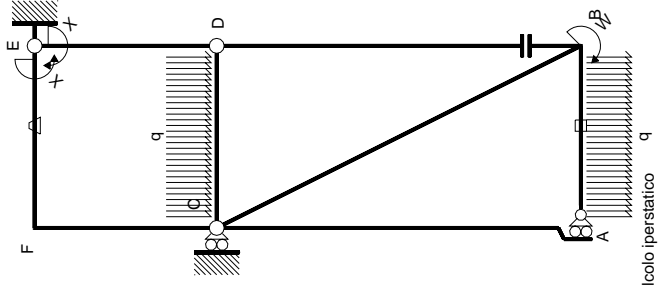

Schema di calcolo iperstatico

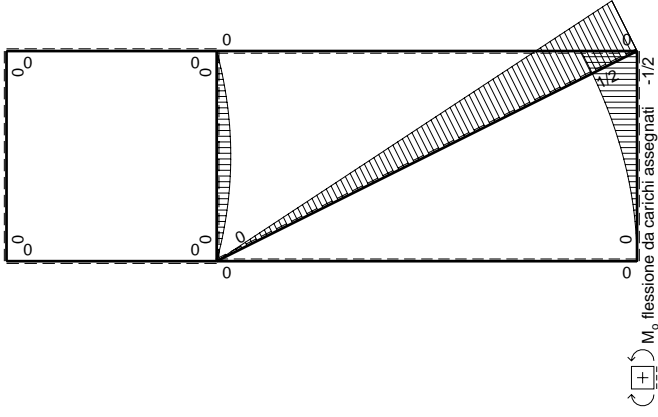

M_0 flessione da carichi assegnati -1/2

Quadro contributi PLV per iperstatica $X=W_{EF}$

\rightarrow	$M_x(x)$	$M_0(x)$	θ	$M_x M_0$	$M_x \theta$	$M_x M_x$	$\int M_x(M_0/EJ+\theta)dx$	$\int X M_x M_x/EJ dx$
AB b	0	$-1/2qx^2$	0	0	0	0	0+0	0
BA b	0	$1/2Fb-Fx+1/2qx^2$	0	0	0	0	0+0	0
BC $\sqrt{5}b$	0	$1/2Fb-\sqrt{5}/10Fx$	0	0	0	0	0	0
AC 2b	0	0	0	0	0	0	0+0	0
CA 2b	0	0	0	0	0	0	0+0	0
DB 2b	0	0	0	0	0	0	0+0	0
BD 2b	0	0	0	0	0	0	0+0	0
DE b	$-x/b$	0	0	0	0	x^2/b^2	0+0	$1/3Xb/EJ$
ED b	$1-x/b$	0	0	0	0	$1-2x/b+x^2/b^2$	0+0	0
CD b	0	$1/2Fx-1/2qx^2$	0	0	0	0	0+0	0
DC b	0	$-1/2Fx+1/2qx^2$	0	0	0	0	0+0	0
EF b	-1	0	$-Fb/EJ$	0	Fb/EJ	1	$(0+1)Fb^2/EJ$	Xb/EJ
FE b	1	0	Fb/EJ	0	Fb/EJ	1		
FC b	$-1+x/b$	0	0	0	0	$1-2x/b+x^2/b^2$	0+0	$1/3Xb/EJ$
CF b	x/b	0	0	0	0	x^2/b^2	Fb^2/EJ	$5/3Xb/EJ$
totali								
iperstatica $X=W_{EF}$								
$-3/5Fb$								

Sviluppi di calcolo iperstatica

M_x flessione da iperstatica $X=1$

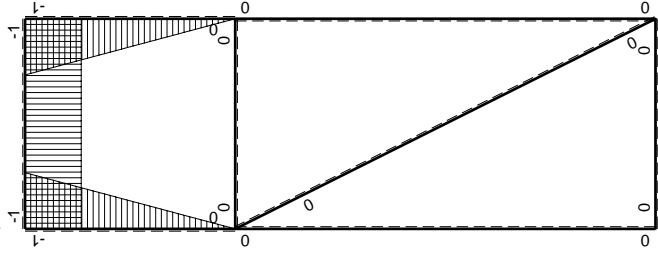

$$L_{DE}^{xx} = \int_0^b (x^2/b^2) 1/EJ dx = [1/3 x^3/b^2]_0^b 1/EJ$$

$$= (1/3 b) 1/EJ = 1/3 b/EJ$$

$$L_{ED}^{xx} = \int_0^b (1 - 2x/b + x^2/b^2) 1/EJ dx = [x - x^2/b + 1/3 x^3/b^2]_0^b 1/EJ$$

$$= (b - b + 1/3 b) 1/EJ = 1/3 b/EJ$$

$$L_{EF}^{xx} = \int_0^b (1) 1/EJ dx = [x]_0^b 1/EJ$$

$$= (b) 1/EJ = b/EJ$$

$$L_{FE}^{xx} = \int_0^b (1) 1/EJ dx = [x]_0^b 1/EJ$$

$$= (b) 1/EJ = b/EJ$$

$$L_{FC}^{xx} = \int_0^b (1 - 2x/b + x^2/b^2) 1/EJ dx = [x - x^2/b + 1/3 x^3/b^2]_0^b 1/EJ$$

$$= (b - b + 1/3 b) 1/EJ = 1/3 b/EJ$$

$$L_{CF}^{xx} = \int_0^b (x^2/b^2) 1/EJ dx = [1/3 x^3/b^2]_0^b 1/EJ$$

$$= (1/3 b) 1/EJ = 1/3 b/EJ$$

$$L_{EF}^{xo} = \int_0^b (1) \theta dx = [x]_0^b \theta$$

$$= (b) \theta = Fb^2/EJ$$

$$L_{FE}^{xo} = \int_0^b (-1) \theta dx = [-x]_0^b \theta$$

$$= (-b) \theta = Fb^2/EJ$$

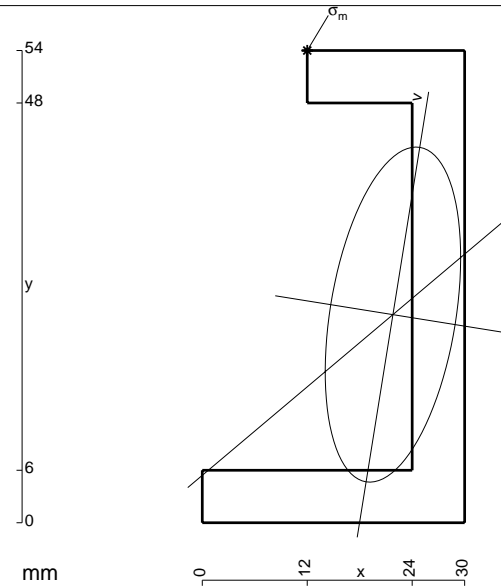

- A = 540. mm²
- J_x = 198266. mm⁴
- J_y = 32378. mm⁴
- J_{xy} = 27302. mm⁴
- J_u = 202644. mm⁴
- J_v = 28000. mm⁴
- α = arctg(2J_{xy}/(J_y-J_x))/2 = -.1590
- c = cosα = .9874
- s = sinα = -.1583
- x_g = 21.8 mm
- y_g = 23.8 mm
- N = -1542. N
- M_x = 986880. Nmm
- x_m = 12. mm
- y_m = 54. mm
- u_m = -14.46 mm
- v_m = 28.27 mm
- σ_m = N/A-Mcv/J_u-Msu/J_v = -219.5 N/mm²

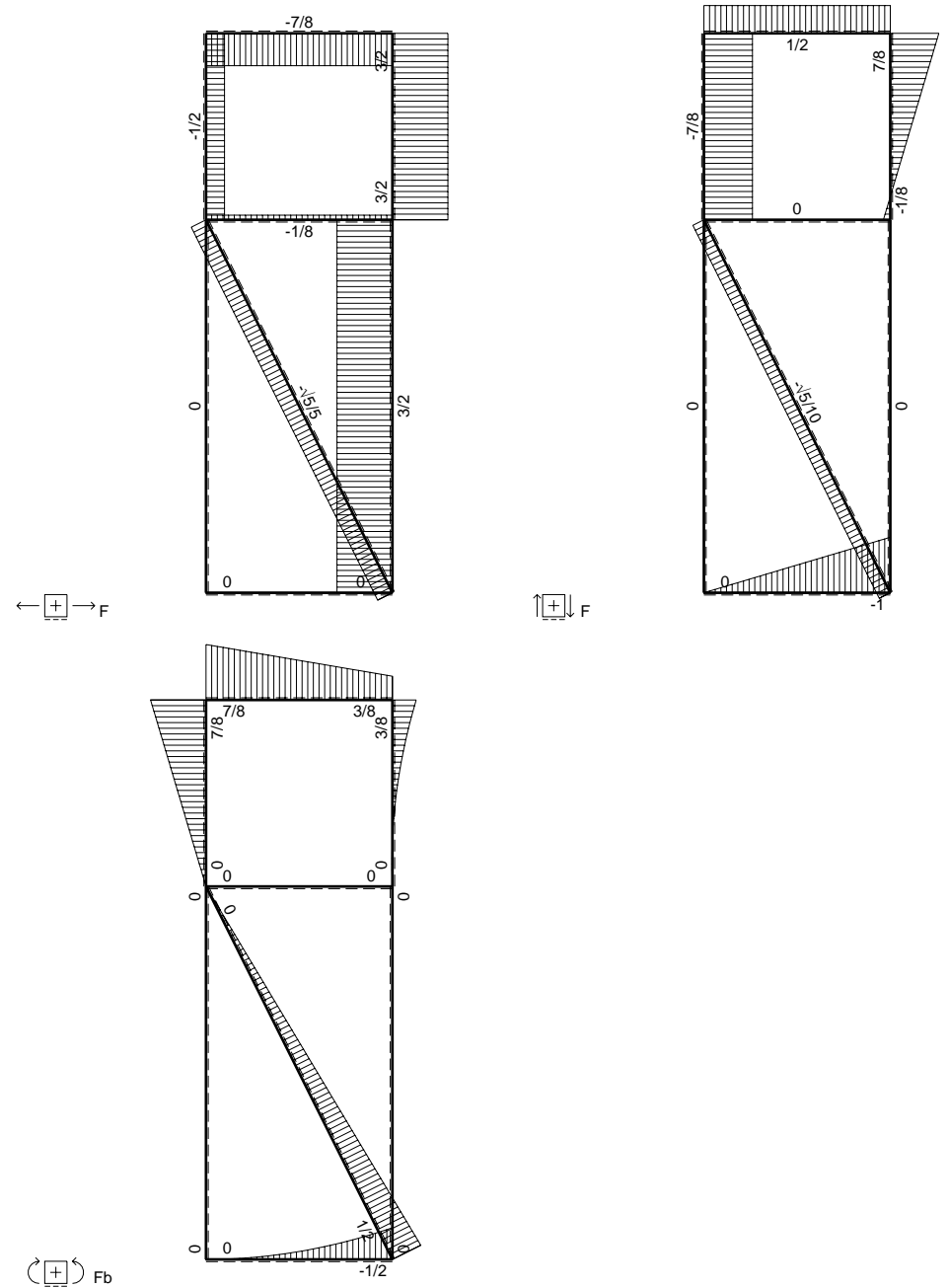
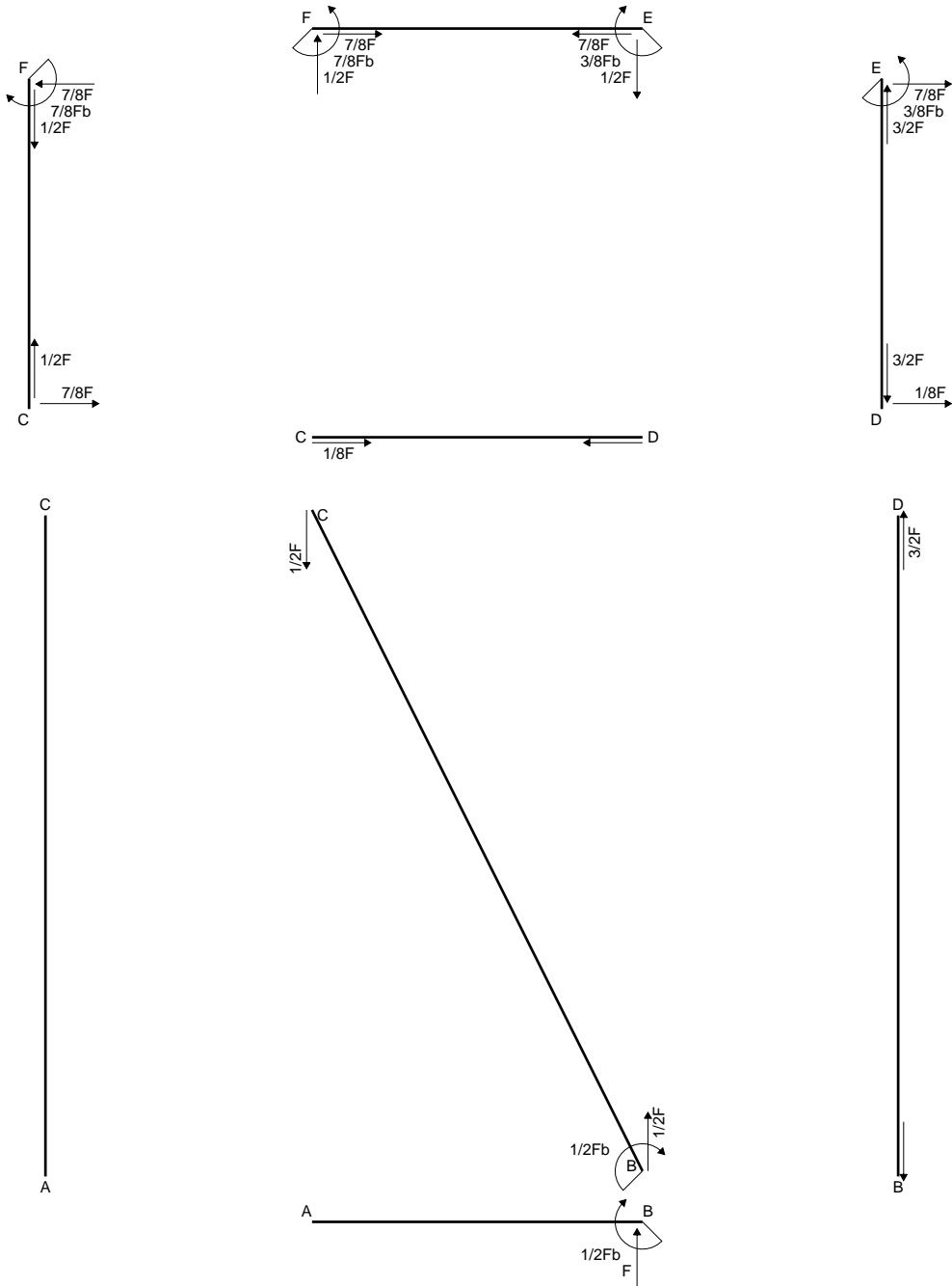

$\leftarrow \boxed{+} \rightarrow F$

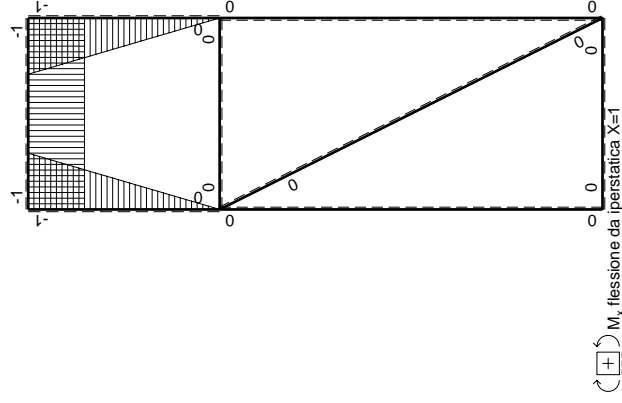
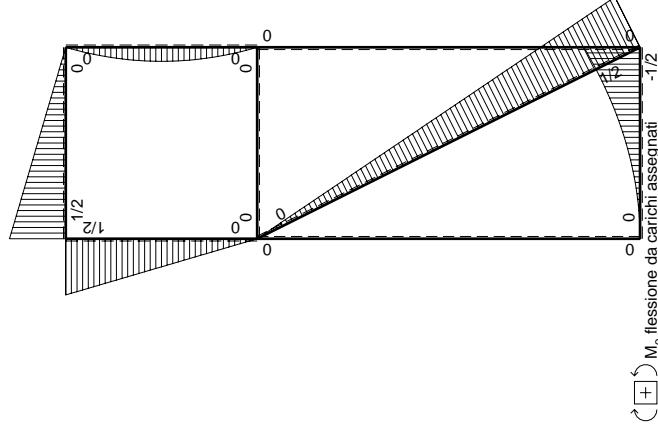
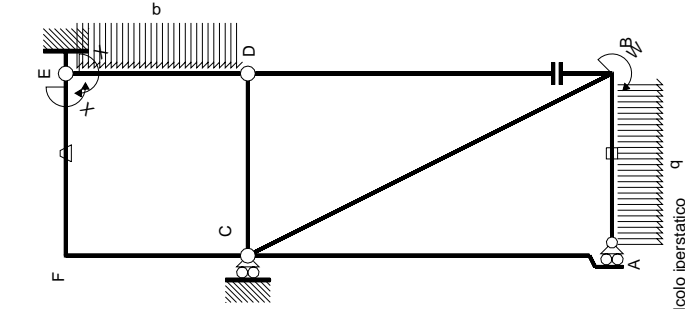

Quadro contributi PLV per iperstatica X=W^{EP}

←	$M_x(x)$	$M_0(x)$	θ	$M_x M_0$	$M_x \theta$	$M_x M_x$	$\int M_x(M_0/EJ+\theta)dx$	$\int M_x M_x / Edx$	AB B	BA B	BC √5b	CA 2b	DB 2b	BD 2b	DE B	ED B	CD B	DC B	EF B	FE B	FC B	CF B	totali	iperstatica X=W ^{EP}													
	0	-1/2qx ²	0	0	0	0	0	0	0	0	1/2Fb-Fx+1/2qx ²	0	0	0	0	-1/2Fx+1/2qx ²	0	0	0	1/2Fx	-Fb/EJ	-1/2Fx	-1+x/b	1/2Fb-1/2Fx	0	0	-1/2Fx	0	0	-1/2Fx ² /b	-1/2Fb+Fx-1/2Fx ² /b	0	0	1-2x/b+x ² /b ²	(-1/6+0)Fb ² /EJ	1/3xb/EJ	5/8Fb ² /EJ

Svilupi di calcolo iperstatica

$$L_{DE}^{xx} = \int_0^b (x^2/b^2) 1/EJ dx = [1/3 x^3/b^2]_0^b 1/EJ$$

$$= (1/3 b) 1/EJ = 1/3 b/EJ$$

$$L_{ED}^{xx} = \int_0^b (1 - 2x/b + x^2/b^2) 1/EJ dx = [x - x^2/b + 1/3 x^3/b^2]_0^b 1/EJ$$

$$= (b - b + 1/3 b) 1/EJ = 1/3 b/EJ$$

$$L_{EF}^{xx} = \int_0^b (1) 1/EJ dx = [x]_0^b 1/EJ$$

$$= (b) 1/EJ = b/EJ$$

$$L_{FE}^{xx} = \int_0^b (1) 1/EJ dx = [x]_0^b 1/EJ$$

$$= (b) 1/EJ = b/EJ$$

$$L_{FC}^{xx} = \int_0^b (1 - 2x/b + x^2/b^2) 1/EJ dx = [x - x^2/b + 1/3 x^3/b^2]_0^b 1/EJ$$

$$= (b - b + 1/3 b) 1/EJ = 1/3 b/EJ$$

$$L_{CF}^{xx} = \int_0^b (x^2/b^2) 1/EJ dx = [1/3 x^3/b^2]_0^b 1/EJ$$

$$= (1/3 b) 1/EJ = 1/3 b/EJ$$

$$L_{DE}^{xo} = \int_0^b (1/2 x^2/b^2 - 1/2 x^3/b^3) Fb 1/EJ dx = [1/6 x^3/b^2 - 1/8 x^4/b^3]_0^b Fb 1/EJ$$

$$= (1/6 b - 1/8 b) Fb 1/EJ = 1/24 Fb^2/EJ$$

$$L_{ED}^{xo} = \int_0^b (1/2 x/b - x^2/b^2 + 1/2 x^3/b^3) Fb 1/EJ dx = [1/4 x^2/b - 1/3 x^3/b^2 + 1/8 x^4/b^3]_0^b Fb 1/EJ$$

$$= (1/4 b - 1/3 b + 1/8 b) Fb 1/EJ = 1/24 Fb^2/EJ$$

$$L_{EF}^{xo} = \int_0^b (-1/2 x/b) Fb 1/EJ dx + \int_0^b (1) \theta dx = [-1/4 x^2/b]_0^b Fb 1/EJ + [x]_0^b \theta$$

$$= (-1/4 b) Fb 1/EJ + (b) \theta = 3/4 Fb^2/EJ$$

$$L_{FE}^{xo} = \int_0^b (-1/2 + 1/2 x/b) Fb 1/EJ dx + \int_0^b (-1) \theta dx = [-1/2 x + 1/4 x^2/b]_0^b Fb 1/EJ + [-x]_0^b \theta$$

$$= (-1/2 b + 1/4 b) Fb 1/EJ + (-b) \theta = 3/4 Fb^2/EJ$$

$$L_{FC}^{xo} = \int_0^b (-1/2 + x/b - 1/2 x^2/b^2) Fb 1/EJ dx = [-1/2 x + 1/2 x^2/b - 1/6 x^3/b^2]_0^b Fb 1/EJ$$

$$= (-1/2 b + 1/2 b - 1/6 b) Fb 1/EJ = -1/6 Fb^2/EJ$$

$$L_{CF}^{xo} = \int_0^b (-1/2 x^2/b^2) Fb 1/EJ dx = [-1/6 x^3/b^2]_0^b Fb 1/EJ$$

$$= (-1/6 b) Fb 1/EJ = -1/6 Fb^2/EJ$$

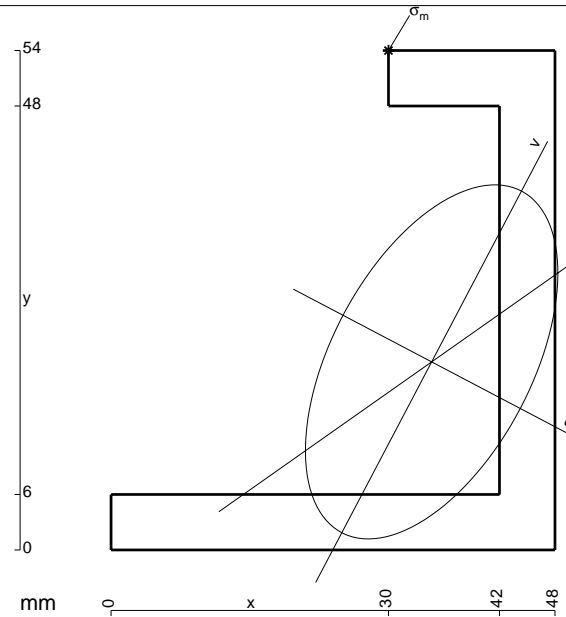

- A = 648. mm²
- J_x = 237528. mm⁴
- J_y = 120672. mm⁴
- J_{xy} = 84960. mm⁴
- J_u = 282212. mm⁴
- J_v = 75988. mm⁴
- α = arctg(2J_{xy}/(J_y-J_x))/2 = -.4842
- c = cos α = .8851
- s = sin α = -.4655
- x_g = 34.67 mm
- y_g = 20.33 mm
- N = -1601. N
- T_y = 915. N
- M_x = 1088850. Nmm
- x_m = 30. mm
- y_m = 54. mm
- u_m = -19.8 mm
- v_m = 27.62 mm
- σ_m = N/A - Mc_v/J_u - Ms_u/J_v = -228.9 N/mm²

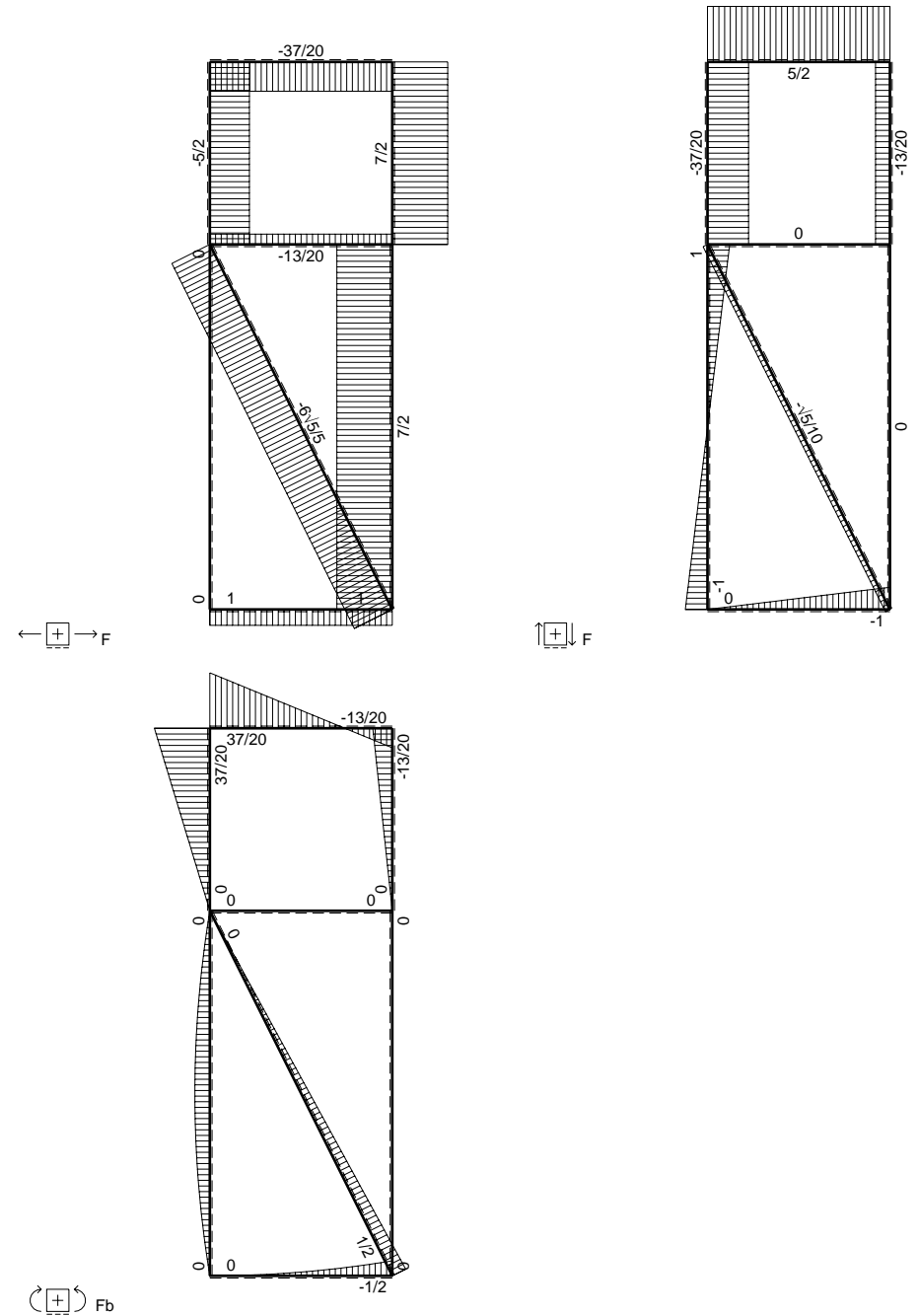
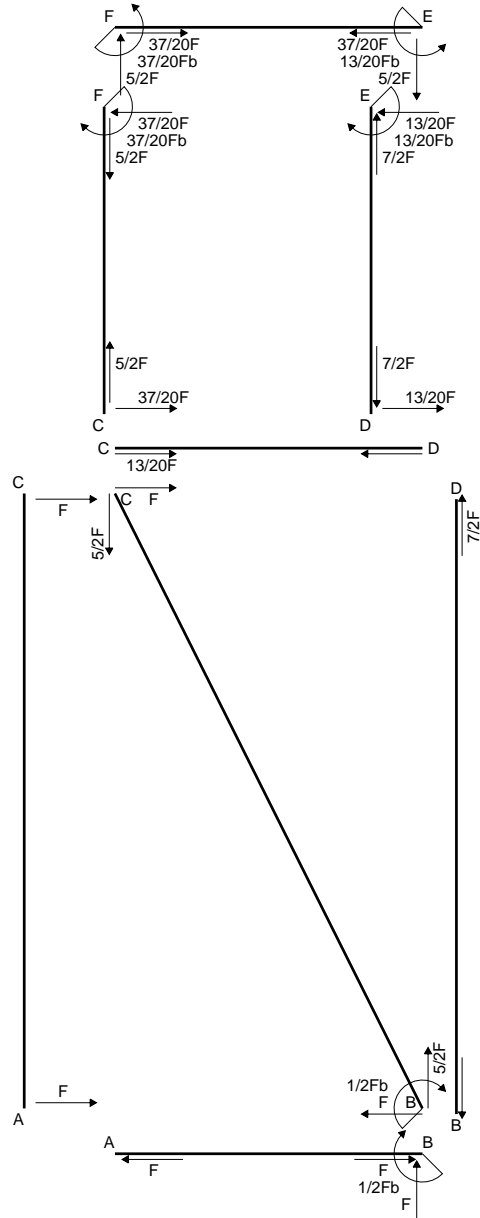

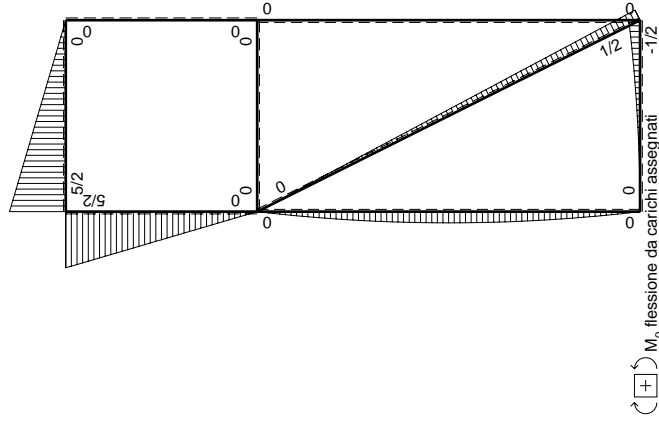
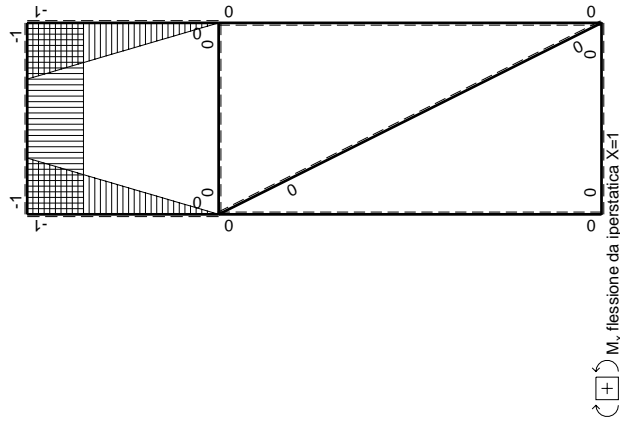
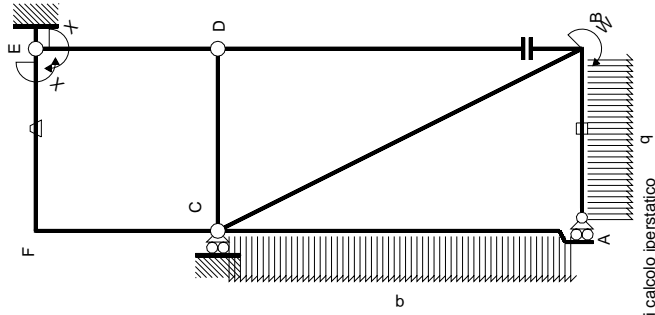

Quadro contributi PLV per iperstatica $X=W_{EP}$

\rightarrow	$M(x)$	$M_0(x)$	θ	$M_x M_0$	$M_x \theta$	$M_x M_x$	$\int M_x(M_0/EJ+\theta)dx$	$\int M_x M_x/EJ dx$
AB b	0	$-1/2qx^2$	0	0	0	0	0	0
BA b	0	$1/2Fb-Fx+1/2qx^2$	0	0	0	0	0	0
BC $\sqrt{5}b$	0	$1/2Fb-\sqrt{5}/10Fx$	0	0	0	0	0	0
AC 2b	0	$-Fx+1/2qx^2$	0	0	0	0	0	0
CA 2b	0	$Fx-1/2qx^2$	0	0	0	0	0	0
DB 2b	0	0	0	0	0	0	0	0
BD 2b	0	0	0	0	0	0	0	0
DE b	$-x/b$	0	0	0	0	x^2/b^2	0	0
ED b	$1-x/b$	0	0	0	0	$1-2x/b+x^2/b^2$	0	$1/3xb/EJ$
CD b	0	0	0	0	0	0	0	0
DC b	0	0	0	0	0	0	0	0
EF b	-1	$5/2Fx$	$-Fb/EJ$	$-5/2Fx$	Fb/EJ	1	$(-5/4+1)Fb^2/EJ$	xb/EJ
FE b	1	$-5/2Fb+5/2Fx$	Fb/EJ	$-5/2Fb+5/2Fx$	Fb/EJ	1	$(-5/4+1)Fb^2/EJ$	xb/EJ
FC b	$-1+x/b$	$5/2Fb-5/2Fx$	0	$-5/2Fb+5Fx-5/2Fx^2/b$	0	$1-2x/b+x^2/b^2$	$(-5/6+0)Fb^2/EJ$	$1/3xb/EJ$
CF b	x/b	$-5/2Fx$	0	$-5/2Fx^2/b$	0	x^2/b^2	$(-5/6+0)Fb^2/EJ$	$1/3xb/EJ$
totali							$-13/12Fb^2/EJ$	$5/3xb/EJ$
								$13/20Fb$

Sviluppi di calcolo iperstatica

$$L_{DE}^{xx} = \int_0^b (x^2/b^2) 1/EJ dx = [1/3 x^3/b^2]_0^b 1/EJ$$

$$= (1/3 b) 1/EJ = 1/3 b/EJ$$

$$L_{ED}^{xx} = \int_0^b (1 - 2x/b + x^2/b^2) 1/EJ dx = [x - x^2/b + 1/3 x^3/b^2]_0^b 1/EJ$$

$$= (b - b + 1/3 b) 1/EJ = 1/3 b/EJ$$

$$L_{EF}^{xx} = \int_0^b (1) 1/EJ dx = [x]_0^b 1/EJ$$

$$= (b) 1/EJ = b/EJ$$

$$L_{FE}^{xx} = \int_0^b (1) 1/EJ dx = [x]_0^b 1/EJ$$

$$= (b) 1/EJ = b/EJ$$

$$L_{FC}^{xx} = \int_0^b (1 - 2x/b + x^2/b^2) 1/EJ dx = [x - x^2/b + 1/3 x^3/b^2]_0^b 1/EJ$$

$$= (b - b + 1/3 b) 1/EJ = 1/3 b/EJ$$

$$L_{CF}^{xx} = \int_0^b (x^2/b^2) 1/EJ dx = [1/3 x^3/b^2]_0^b 1/EJ$$

$$= (1/3 b) 1/EJ = 1/3 b/EJ$$

$$L_{EF}^{xo} = \int_0^b (-5/2 x/b) Fb 1/EJ dx + \int_0^b (1) \theta dx = [-5/4 x^2/b]_0^b Fb 1/EJ + [x]_0^b \theta$$

$$= (-5/4 b) Fb 1/EJ + (b) \theta = -1/4 Fb^2/EJ$$

$$L_{FE}^{xo} = \int_0^b (-5/2 + 5/2 x/b) Fb 1/EJ dx + \int_0^b (-1) \theta dx = [-5/2 x + 5/4 x^2/b]_0^b Fb 1/EJ + [-x]_0^b \theta$$

$$= (-5/2 b + 5/4 b) Fb 1/EJ + (-b) \theta = -1/4 Fb^2/EJ$$

$$L_{FC}^{xo} = \int_0^b (-5/2 + 5x/b - 5/2 x^2/b^2) Fb 1/EJ dx = [-5/2 x + 5/2 x^2/b - 5/6 x^3/b^2]_0^b Fb 1/EJ$$

$$= (-5/2 b + 5/2 b - 5/6 b) Fb 1/EJ = -5/6 Fb^2/EJ$$

$$L_{CF}^{xo} = \int_0^b (-5/2 x^2/b^2) Fb 1/EJ dx = [-5/6 x^3/b^2]_0^b Fb 1/EJ$$

$$= (-5/6 b) Fb 1/EJ = -5/6 Fb^2/EJ$$

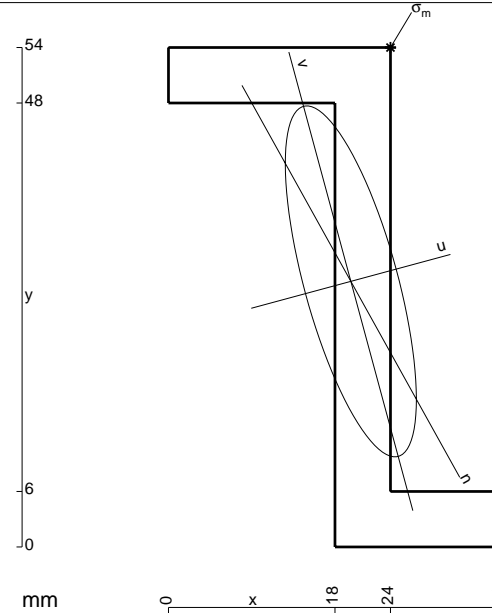

- A = 504. mm²
- J_x = 181471. mm⁴
- J_y = 25303. mm⁴
- J_{xy} = -45545. mm⁴
- J_u = 193783. mm⁴
- J_v = 12991. mm⁴
- α = arctg(2J_{xy}/(J_y-J_x))/2 = .2640
- c = cos α = .9653
- s = sin α = .2610
- x_g = 19.71 mm
- y_g = 28.71 mm
- N = -1325. N
- T_y = -980.5 N
- M_x = 705960. Nmm
- x_m = 24. mm
- y_m = 54. mm
- u_m = 10.74 mm
- v_m = 23.29 mm
- σ_m = N/A - Mcv/J_u - Msu/J_v = -236.8 N/mm²

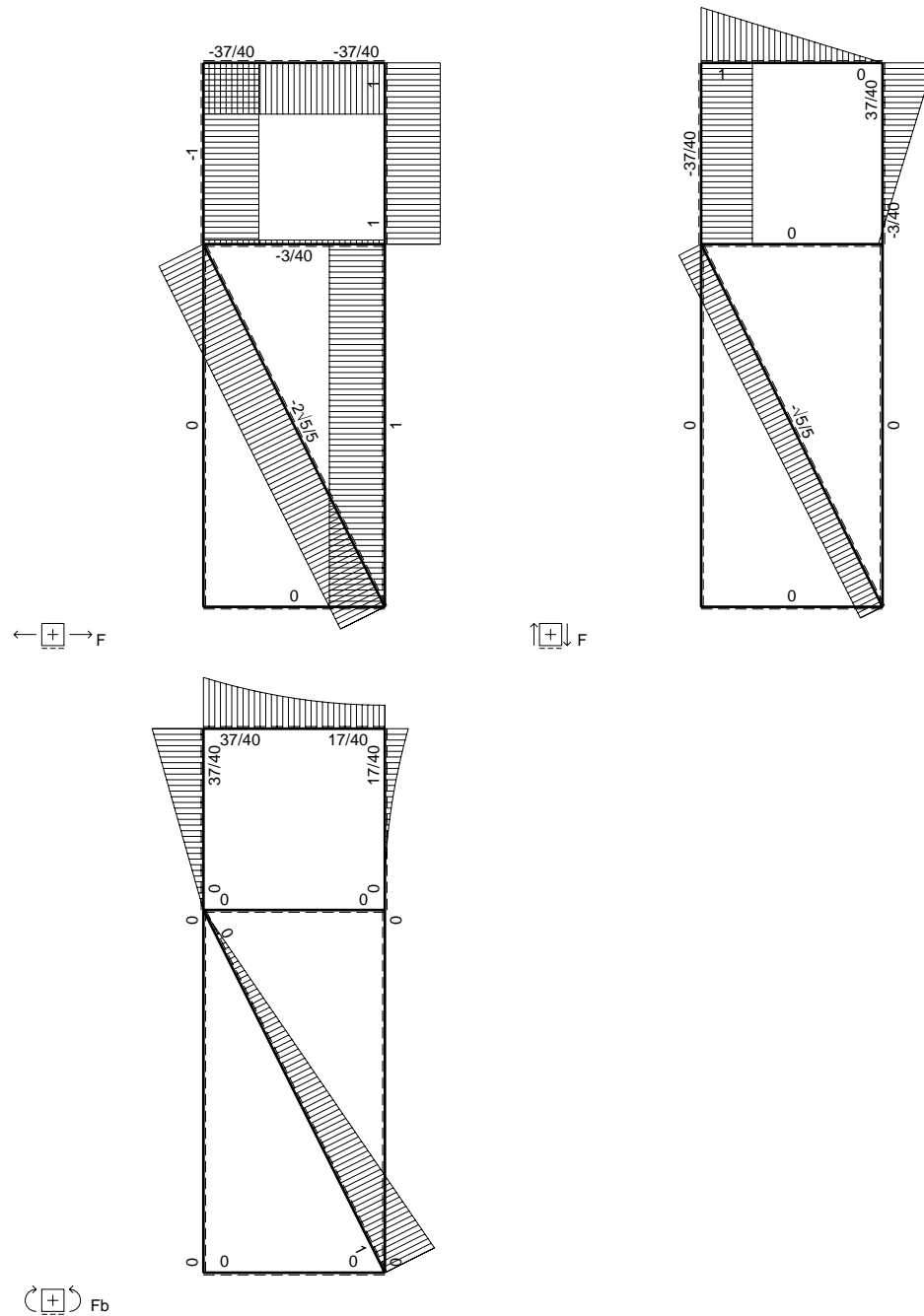
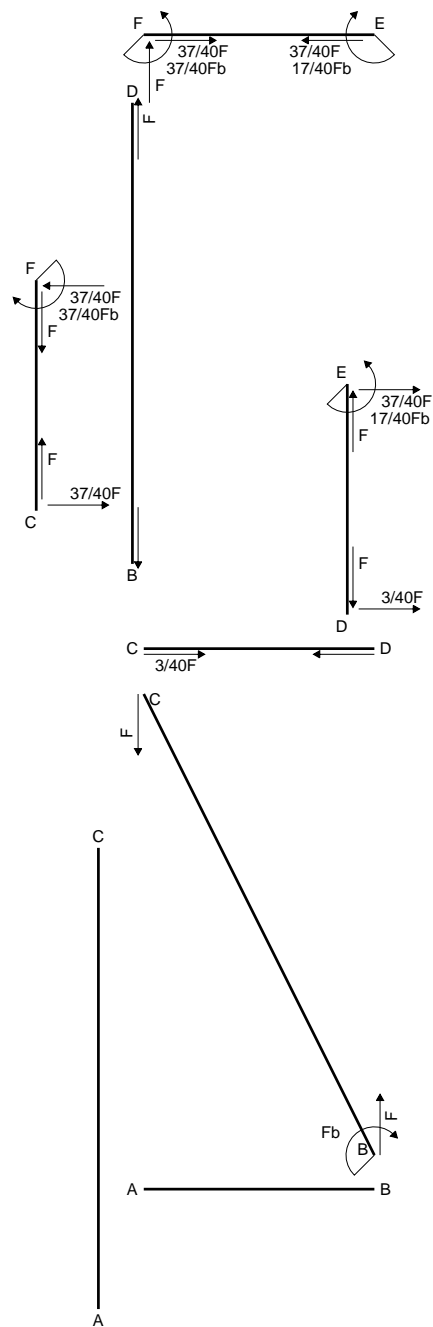

$$L_{DE}^{xx} = \int_0^b (x^2/b^2) 1/EJ dx = [1/3 x^3/b^2]_0^b 1/EJ$$

$$= (1/3 b) 1/EJ = 1/3 b/EJ$$

$$L_{ED}^{xx} = \int_0^b (1 - 2x/b + x^2/b^2) 1/EJ dx = [x - x^2/b + 1/3 x^3/b^2]_0^b 1/EJ$$

$$= (b - b + 1/3 b) 1/EJ = 1/3 b/EJ$$

$$L_{EF}^{xx} = \int_0^b (1) 1/EJ dx = [x]_0^b 1/EJ$$

$$= (b) 1/EJ = b/EJ$$

$$L_{FE}^{xx} = \int_0^b (1) 1/EJ dx = [x]_0^b 1/EJ$$

$$= (b) 1/EJ = b/EJ$$

$$L_{FC}^{xx} = \int_0^b (1 - 2x/b + x^2/b^2) 1/EJ dx = [x - x^2/b + 1/3 x^3/b^2]_0^b 1/EJ$$

$$= (b - b + 1/3 b) 1/EJ = 1/3 b/EJ$$

$$L_{CF}^{xx} = \int_0^b (x^2/b^2) 1/EJ dx = [1/3 x^3/b^2]_0^b 1/EJ$$

$$= (1/3 b) 1/EJ = 1/3 b/EJ$$

$$L_{DE}^{xo} = \int_0^b (1/2 x^2/b^2 - 1/2 x^3/b^3) Fb 1/EJ dx = [1/6 x^3/b^2 - 1/8 x^4/b^3]_0^b Fb 1/EJ$$

$$= (1/6 b - 1/8 b) Fb 1/EJ = 1/24 Fb^2/EJ$$

$$L_{ED}^{xo} = \int_0^b (1/2 x/b - x^2/b^2 + 1/2 x^3/b^3) Fb 1/EJ dx = [1/4 x^2/b - 1/3 x^3/b^2 + 1/8 x^4/b^3]_0^b Fb 1/EJ$$

$$= (1/4 b - 1/3 b + 1/8 b) Fb 1/EJ = 1/24 Fb^2/EJ$$

$$L_{EF}^{xo} = \int_0^b (-1/2 x^2/b^2) Fb 1/EJ dx + \int_0^b (1) \theta dx = [-1/6 x^3/b^2]_0^b Fb 1/EJ + [x]_0^b \theta$$

$$= (-1/6 b) Fb 1/EJ + (b) \theta = 5/6 Fb^2/EJ$$

$$L_{FE}^{xo} = \int_0^b (-1/2 + x/b - 1/2 x^2/b^2) Fb 1/EJ dx + \int_0^b (-1) \theta dx$$

$$= [-1/2 x + 1/2 x^2/b - 1/6 x^3/b^2]_0^b Fb 1/EJ + [-x]_0^b \theta$$

$$= (-1/2 b + 1/2 b - 1/6 b) Fb 1/EJ + (-b) \theta = 5/6 Fb^2/EJ$$

$$L_{FC}^{xo} = \int_0^b (-1/2 + x/b - 1/2 x^2/b^2) Fb 1/EJ dx = [-1/2 x + 1/2 x^2/b - 1/6 x^3/b^2]_0^b Fb 1/EJ$$

$$= (-1/2 b + 1/2 b - 1/6 b) Fb 1/EJ = -1/6 Fb^2/EJ$$

$$L_{CF}^{xo} = \int_0^b (-1/2 x^2/b^2) Fb 1/EJ dx = [-1/6 x^3/b^2]_0^b Fb 1/EJ$$

$$= (-1/6 b) Fb 1/EJ = -1/6 Fb^2/EJ$$

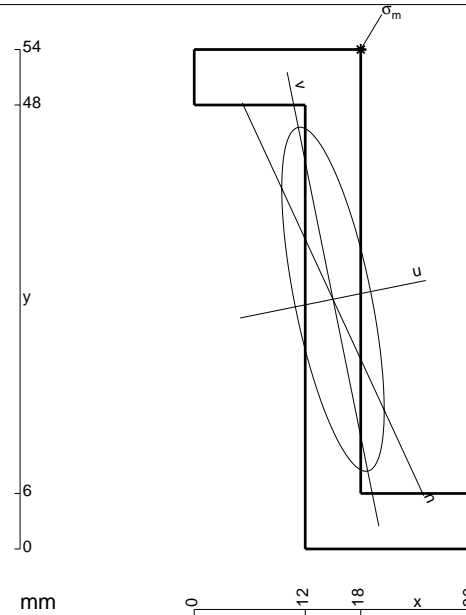

- A = 468. mm²
- J_x = 162108. mm⁴
- J_y = 14364. mm⁴
- J_{xy} = -31104. mm⁴
- J_u = 168389. mm⁴
- J_v = 8083. mm⁴
- α = arctg(2J_{xy}/(J_y-J_x))/2 = .1993
- c = cos α = .9802
- s = sin α = .1979
- x_g = 15. mm
- y_g = 27. mm
- N = -1306. N
- T_y = -652.9 N
- M_x = 554800. Nmm
- x_m = 18. mm
- y_m = 54. mm
- u_m = 8.285 mm
- v_m = 25.87 mm
- σ_m = N/A - Mc_v/J_u - Ms_u/J_v = -198.9 N/mm²

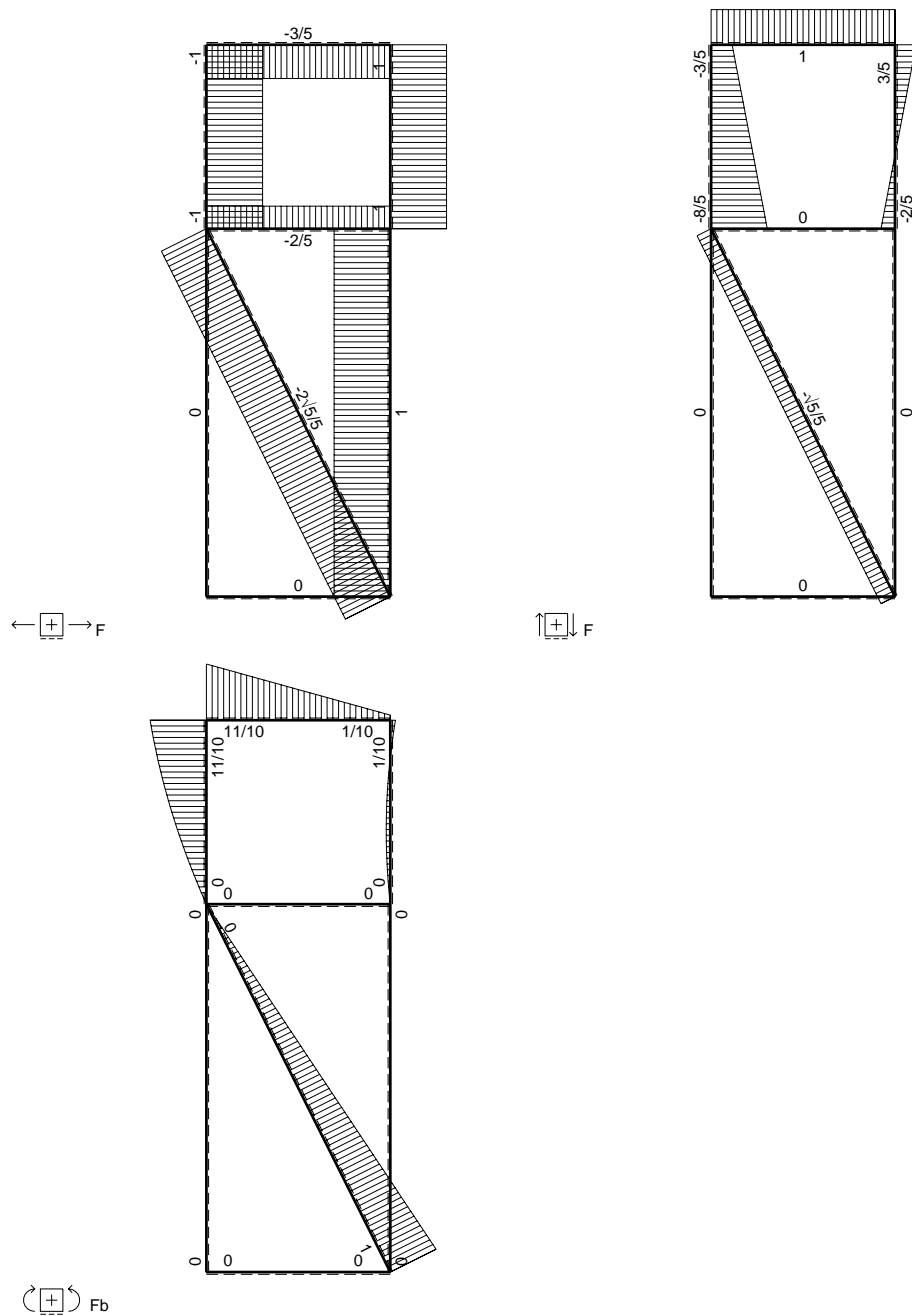
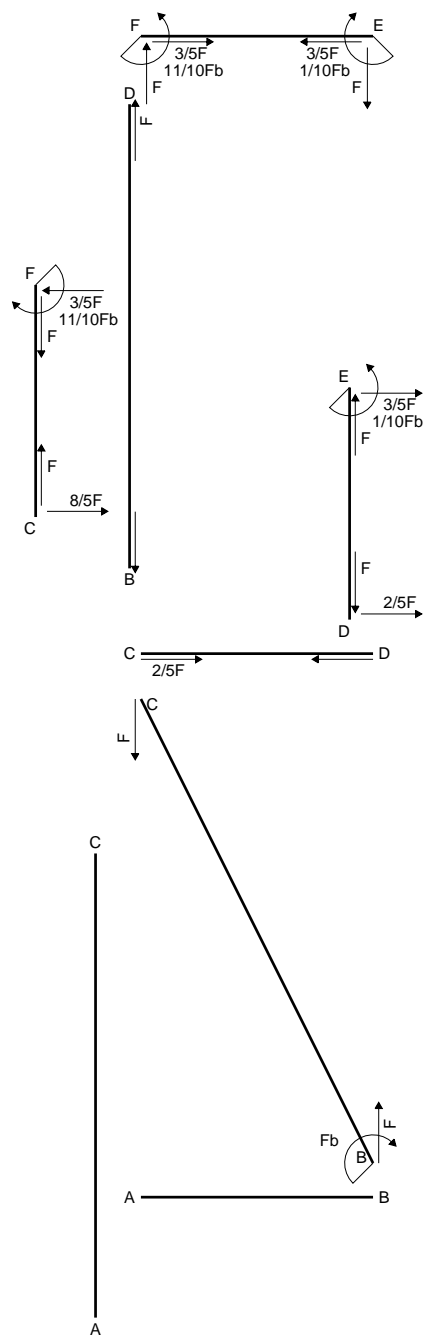

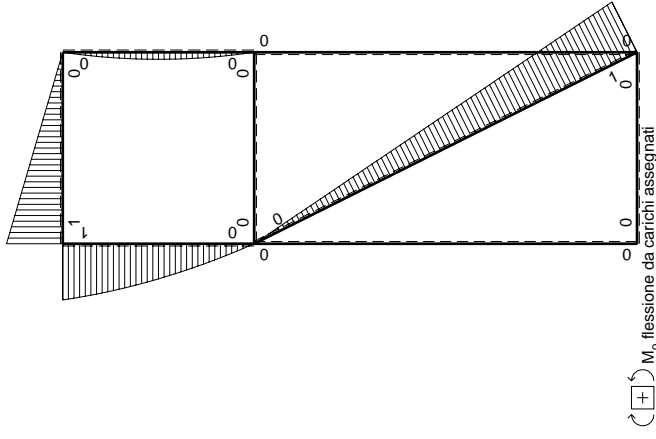
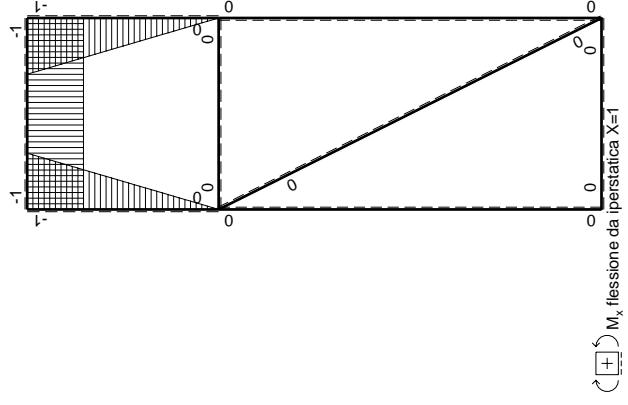
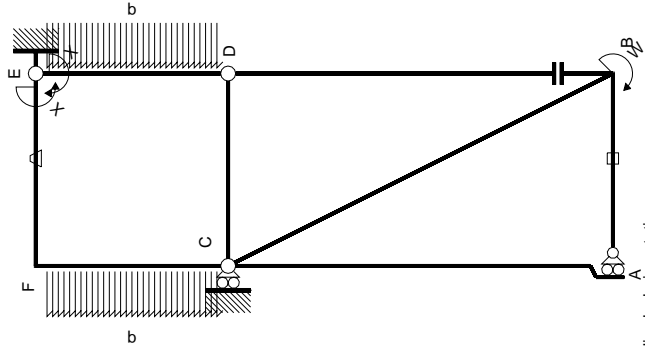

Quadro contributi PLV per iperstatica $X=W_{EF}$

\rightarrow	$M(x)$	$M_0(x)$	θ	$M_x M_0$	$M_x \theta$	$M_x M_x$	$\int M_x(M_0/EJ+\theta)dx$	$\int M_x M_x/EJ dx$
AB b	0	0	0	0	0	0	0+0	0
BA b	0	0	0	0	0	0	0	0
BC $\sqrt{5}b$	0	$Fb-\sqrt{5}/5Fx$	0	0	0	0	0	0
CA 2b	0	0	0	0	0	0	0+0	0
DB 2b	0	0	0	0	0	0	0+0	0
BD 2b	0	0	0	0	0	0	0	0
DE b	$-x/b$	$-1/2Fx+1/2qx^2$	0	$1/2Fx^2/b-1/2qx^3/b$	0	0	x^2/b^2	0
ED b	$1-x/b$	$1/2Fx-1/2qx^2$	0	$1/2Fx-Fx^2/b+1/2qx^3/b$	0	0	$1-2x/b+x^2/b^2$	$1/3xb/EJ$
CD b	0	0	0	0	0	0	0+0	0
FE b	-1	Fx	$-Fb/EJ$	-Fx	Fb/EJ	1	$(-1/2+1)Fb^2/EJ$	xb/EJ
FC b	$-1+x/b$	$-Fb-1/2Fx-1/2qx^2$	0	$-Fb+3/2Fx-1/2qx^3/b$	0	0	$1-2x/b+x^2/b^2$	$1/3xb/EJ$
CF b	x/b	$-3/2Fx+1/2qx^2$	0	$-3/2Fx^2/b+1/2qx^3/b$	0	0	x^2/b^2	$1/6Fb^2/EJ$
totali								$5/3xb/EJ$
iperstatica $X=W_{EF}$								$-1/10Fb$

Sviluppi di calcolo iperstatica

$$L_{DE}^{xx} = \int_0^b (x^2/b^2) 1/EJ dx = [1/3 x^3/b^2]_0^b 1/EJ$$

$$= (1/3 b) 1/EJ = 1/3 b/EJ$$

$$L_{ED}^{xx} = \int_0^b (1 - 2x/b + x^2/b^2) 1/EJ dx = [x - x^2/b + 1/3 x^3/b^2]_0^b 1/EJ$$

$$= (b - b + 1/3 b) 1/EJ = 1/3 b/EJ$$

$$L_{EF}^{xx} = \int_0^b (1) 1/EJ dx = [x]_0^b 1/EJ$$

$$= (b) 1/EJ = b/EJ$$

$$L_{FE}^{xx} = \int_0^b (1) 1/EJ dx = [x]_0^b 1/EJ$$

$$= (b) 1/EJ = b/EJ$$

$$L_{FC}^{xx} = \int_0^b (1 - 2x/b + x^2/b^2) 1/EJ dx = [x - x^2/b + 1/3 x^3/b^2]_0^b 1/EJ$$

$$= (b - b + 1/3 b) 1/EJ = 1/3 b/EJ$$

$$L_{CF}^{xx} = \int_0^b (x^2/b^2) 1/EJ dx = [1/3 x^3/b^2]_0^b 1/EJ$$

$$= (1/3 b) 1/EJ = 1/3 b/EJ$$

$$L_{DE}^{xo} = \int_0^b (1/2 x^2/b^2 - 1/2 x^3/b^3) Fb 1/EJ dx = [1/6 x^3/b^2 - 1/8 x^4/b^3]_0^b Fb 1/EJ$$

$$= (1/6 b - 1/8 b) Fb 1/EJ = 1/24 Fb^2/EJ$$

$$L_{ED}^{xo} = \int_0^b (1/2 x/b - x^2/b^2 + 1/2 x^3/b^3) Fb 1/EJ dx = [1/4 x^2/b - 1/3 x^3/b^2 + 1/8 x^4/b^3]_0^b Fb 1/EJ$$

$$= (1/4 b - 1/3 b + 1/8 b) Fb 1/EJ = 1/24 Fb^2/EJ$$

$$L_{EF}^{xo} = \int_0^b (-x/b) Fb 1/EJ dx + \int_0^b (1) \theta dx = [-1/2 x^2/b]_0^b Fb 1/EJ + [x]_0^b \theta$$

$$= (-1/2 b) Fb 1/EJ + (b) \theta = 1/2 Fb^2/EJ$$

$$L_{FE}^{xo} = \int_0^b (-1 + x/b) Fb 1/EJ dx + \int_0^b (-1) \theta dx = [-x + 1/2 x^2/b]_0^b Fb 1/EJ + [-x]_0^b \theta$$

$$= (-b + 1/2 b) Fb 1/EJ + (-b) \theta = 1/2 Fb^2/EJ$$

$$L_{FC}^{xo} = \int_0^b (-1 + 3/2 x/b - 1/2 x^3/b^3) Fb 1/EJ dx = [-x + 3/4 x^2/b - 1/8 x^4/b^3]_0^b Fb 1/EJ$$

$$= (-b + 3/4 b - 1/8 b) Fb 1/EJ = -3/8 Fb^2/EJ$$

$$L_{CF}^{xo} = \int_0^b (-3/2 x^2/b^2 + 1/2 x^3/b^3) Fb 1/EJ dx = [-1/2 x^3/b^2 + 1/8 x^4/b^3]_0^b Fb 1/EJ$$

$$= (-1/2 b + 1/8 b) Fb 1/EJ = -3/8 Fb^2/EJ$$

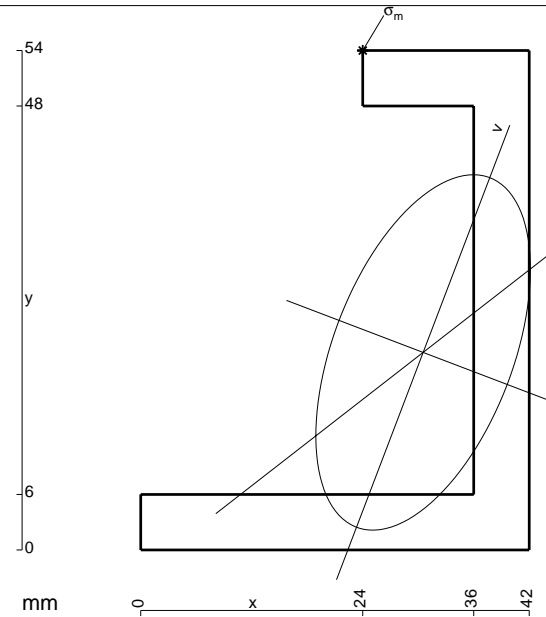

- A = 612. mm²
- J_x = 225968. mm⁴
- J_y = 82341. mm⁴
- J_{xy} = 64038. mm⁴
- J_{x'} = 250373. mm⁴
- J_{y'} = 57936. mm⁴
- α = arctg(2J_{xy}/(J_y-J_x))/2 = -.3641
- c = cos α = .9344
- s = sin α = -.3561
- x_g = 30.53 mm
- y_g = 21.35 mm
- N = -2130. N
- T_y = -1278. N
- M_x = 960630. Nmm
- x_m = 24. mm
- y_m = 54. mm
- u_m = -17.73 mm
- v_m = 28.18 mm
- σ_m = N/A - Mc_v/J_y - Ms_u/J_x = -209.2 N/mm²

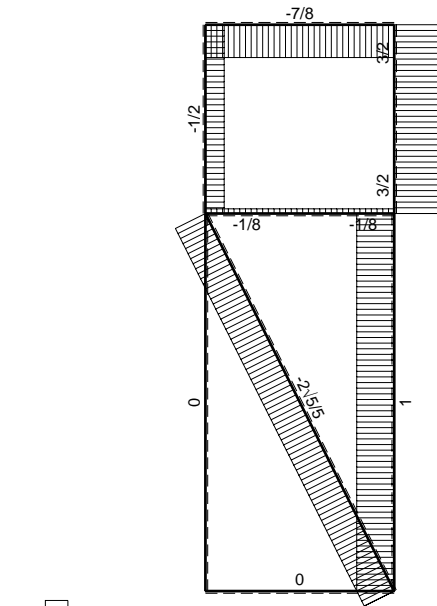
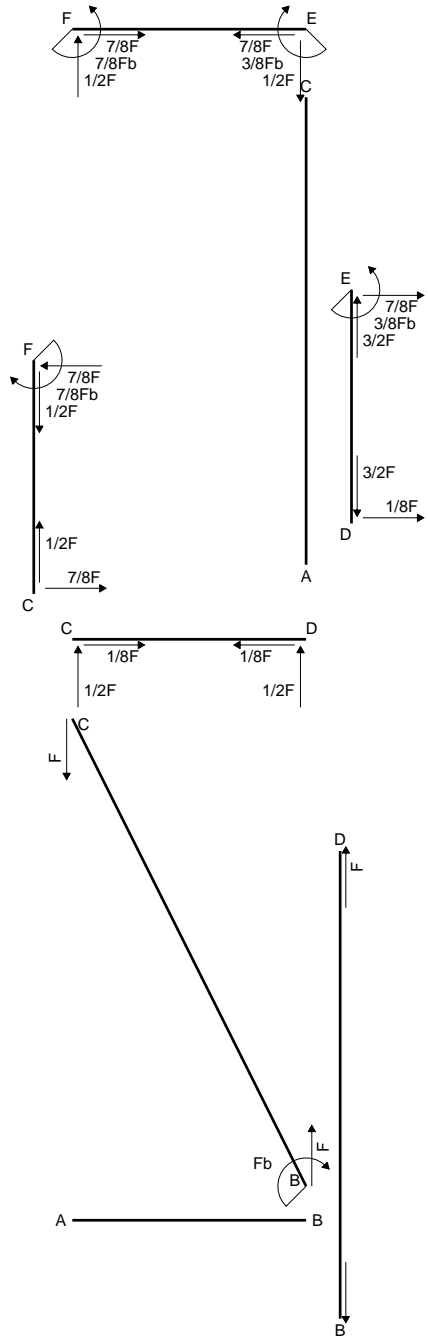

← ⊕ → F

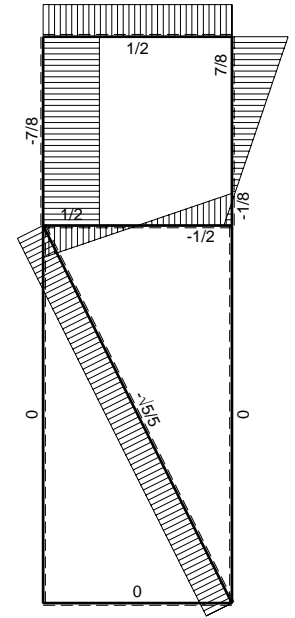

↑ ⊕ ↓ F

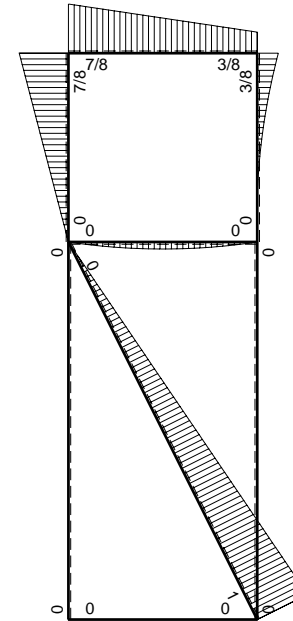

⊙ ⊕ ⊙ F_b

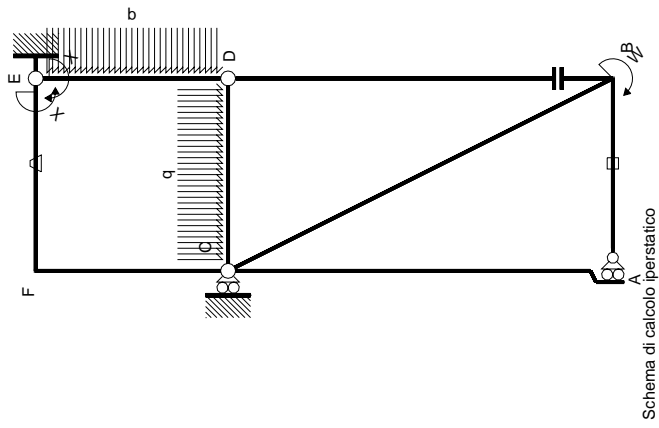

M_0 flessione da carichi assegnati

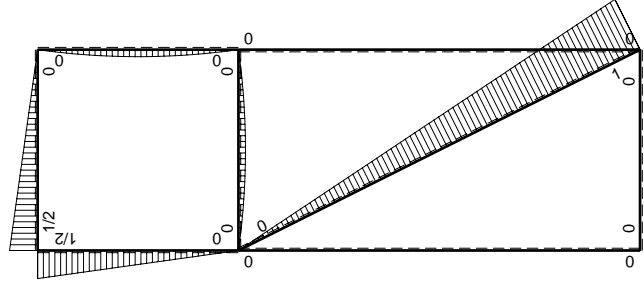

M_x flessione da iperstatica $X=1$

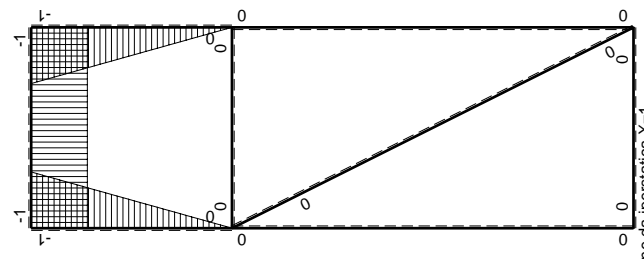

Quadro contributi PLV per iperstatica $X=W_{EF}$		$M^x(x)$	$M^0(x)$	θ	$M^x M_0$	$M^x \theta$	$M^x M_x$	$\int M^x (M_0/EJ + \theta) dx$	$\int M^x M_x / E J dx$
AB b	0	0	0	0	0	0	0	0	0
BA b	0	0	0	0	0	0	0	0	0
BC $\sqrt{5}b$	0	$Fb\sqrt{5}/5Fx$	0	0	0	0	0	0	0
AC 2b	0	0	0	0	0	0	0	0	0
CA 2b	0	0	0	0	0	0	0	0	0
DB 2b	0	0	0	0	0	0	0	0	0
BD 2b	0	0	0	0	0	0	0	0	0
DE b	$-x/b$	$-1/2Fx + 1/2qx^2$	0	$1/2Fx^2/b - 1/2qx^3/b$	0	0	x^2/b^2	$(1/24+0)Fb^2/EJ$	$1/3Xb/EJ$
ED b	$1-x/b$	$1/2Fx - 1/2qx^2$	0	$1/2Fx - Fx^2/b + 1/2qx^3/b$	0	0	$1-2x/b+x^2/b^2$	$(1/24+0)Fb^2/EJ$	$1/3Xb/EJ$
CD b	0	$1/2Fx - 1/2qx^2$	0	0	0	0	0	0	0
DC b	0	$-1/2Fx + 1/2qx^2$	0	0	0	0	0	0	0
EF b	-1	$1/2Fx$	$-Fb/EJ$	$-1/2Fx$	Fb/EJ	Fb/EJ	1	$(-1/4+1)Fb^2/EJ$	Xb/EJ
FE b	1	$-1/2Fb + 1/2Fx$	Fb/EJ	$-1/2Fb + 1/2Fx$	Fb/EJ	Fb/EJ	1	$(-1/4+1)Fb^2/EJ$	Xb/EJ
FC b	$-1+x/b$	$1/2Fb - 1/2Fx$	0	$-1/2Fb + Fx - 1/2Fx^2/b$	0	0	$1-2x/b+x^2/b^2$	$(-1/6+0)Fb^2/EJ$	$1/3Xb/EJ$
CF b	x/b	$-1/2Fx$	0	$-1/2Fx^2/b$	0	0	x^2/b^2	$(-1/6+0)Fb^2/EJ$	$1/3Xb/EJ$
totali								$5/8Fb^2/EJ$	$5/3Xb/EJ$
								$-3/8Fb$	

Sviluppi di calcolo iperstatica

$$L_{DE}^{xx} = \int_0^b (x^2/b^2) 1/EJ dx = [1/3 x^3/b^2]_0^b 1/EJ$$

$$= (1/3 b) 1/EJ = 1/3 b/EJ$$

$$L_{ED}^{xx} = \int_0^b (1 - 2x/b + x^2/b^2) 1/EJ dx = [x - x^2/b + 1/3 x^3/b^2]_0^b 1/EJ$$

$$= (b - b + 1/3 b) 1/EJ = 1/3 b/EJ$$

$$L_{EF}^{xx} = \int_0^b (1) 1/EJ dx = [x]_0^b 1/EJ$$

$$= (b) 1/EJ = b/EJ$$

$$L_{FE}^{xx} = \int_0^b (1) 1/EJ dx = [x]_0^b 1/EJ$$

$$= (b) 1/EJ = b/EJ$$

$$L_{FC}^{xx} = \int_0^b (1 - 2x/b + x^2/b^2) 1/EJ dx = [x - x^2/b + 1/3 x^3/b^2]_0^b 1/EJ$$

$$= (b - b + 1/3 b) 1/EJ = 1/3 b/EJ$$

$$L_{CF}^{xx} = \int_0^b (x^2/b^2) 1/EJ dx = [1/3 x^3/b^2]_0^b 1/EJ$$

$$= (1/3 b) 1/EJ = 1/3 b/EJ$$

$$L_{DE}^{xo} = \int_0^b (1/2 x^2/b^2 - 1/2 x^3/b^3) Fb 1/EJ dx = [1/6 x^3/b^2 - 1/8 x^4/b^3]_0^b Fb 1/EJ$$

$$= (1/6 b - 1/8 b) Fb 1/EJ = 1/24 Fb^2/EJ$$

$$L_{ED}^{xo} = \int_0^b (1/2 x/b - x^2/b^2 + 1/2 x^3/b^3) Fb 1/EJ dx = [1/4 x^2/b - 1/3 x^3/b^2 + 1/8 x^4/b^3]_0^b Fb 1/EJ$$

$$= (1/4 b - 1/3 b + 1/8 b) Fb 1/EJ = 1/24 Fb^2/EJ$$

$$L_{EF}^{xo} = \int_0^b (-1/2 x/b) Fb 1/EJ dx + \int_0^b (1) \theta dx = [-1/4 x^2/b]_0^b Fb 1/EJ + [x]_0^b \theta$$

$$= (-1/4 b) Fb 1/EJ + (b) \theta = 3/4 Fb^2/EJ$$

$$L_{FE}^{xo} = \int_0^b (-1/2 + 1/2 x/b) Fb 1/EJ dx + \int_0^b (-1) \theta dx = [-1/2 x + 1/4 x^2/b]_0^b Fb 1/EJ + [-x]_0^b \theta$$

$$= (-1/2 b + 1/4 b) Fb 1/EJ + (-b) \theta = 3/4 Fb^2/EJ$$

$$L_{FC}^{xo} = \int_0^b (-1/2 + x/b - 1/2 x^2/b^2) Fb 1/EJ dx = [-1/2 x + 1/2 x^2/b - 1/6 x^3/b^2]_0^b Fb 1/EJ$$

$$= (-1/2 b + 1/2 b - 1/6 b) Fb 1/EJ = -1/6 Fb^2/EJ$$

$$L_{CF}^{xo} = \int_0^b (-1/2 x^2/b^2) Fb 1/EJ dx = [-1/6 x^3/b^2]_0^b Fb 1/EJ$$

$$= (-1/6 b) Fb 1/EJ = -1/6 Fb^2/EJ$$

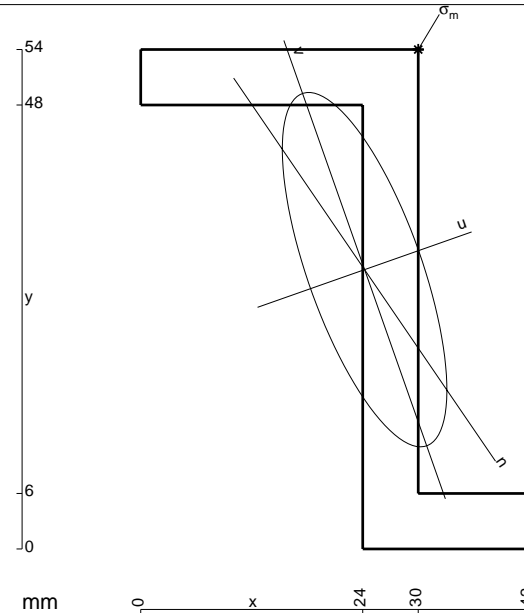

- A = 540. mm²
- J_x = 198266. mm⁴
- J_y = 42746. mm⁴
- J_{xy} = -62554. mm⁴
- J_u = 220304. mm⁴
- J_v = 20709. mm⁴
- α = arctg(2J_{xy}/(J_y-J_x))/2 = .3387
- c = cos α = .9432
- s = sin α = .3323
- x_g = 24.2 mm
- y_g = 30.2 mm
- N = -1422. N
- T_y = -711.1 N
- M_x = 715500. Nmm
- x_m = 30. mm
- y_m = 54. mm
- u_m = 13.38 mm
- v_m = 20.52 mm
- σ_m = N/A - Mcv/J_v - Msu/J_u = -219.1 N/mm²

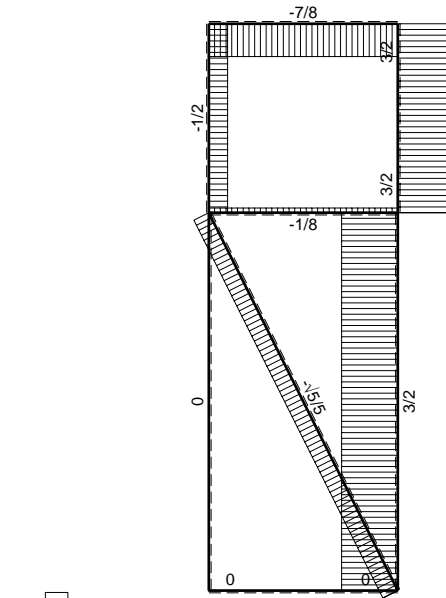
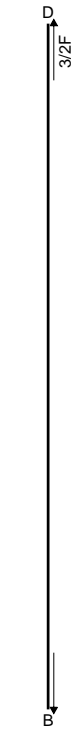
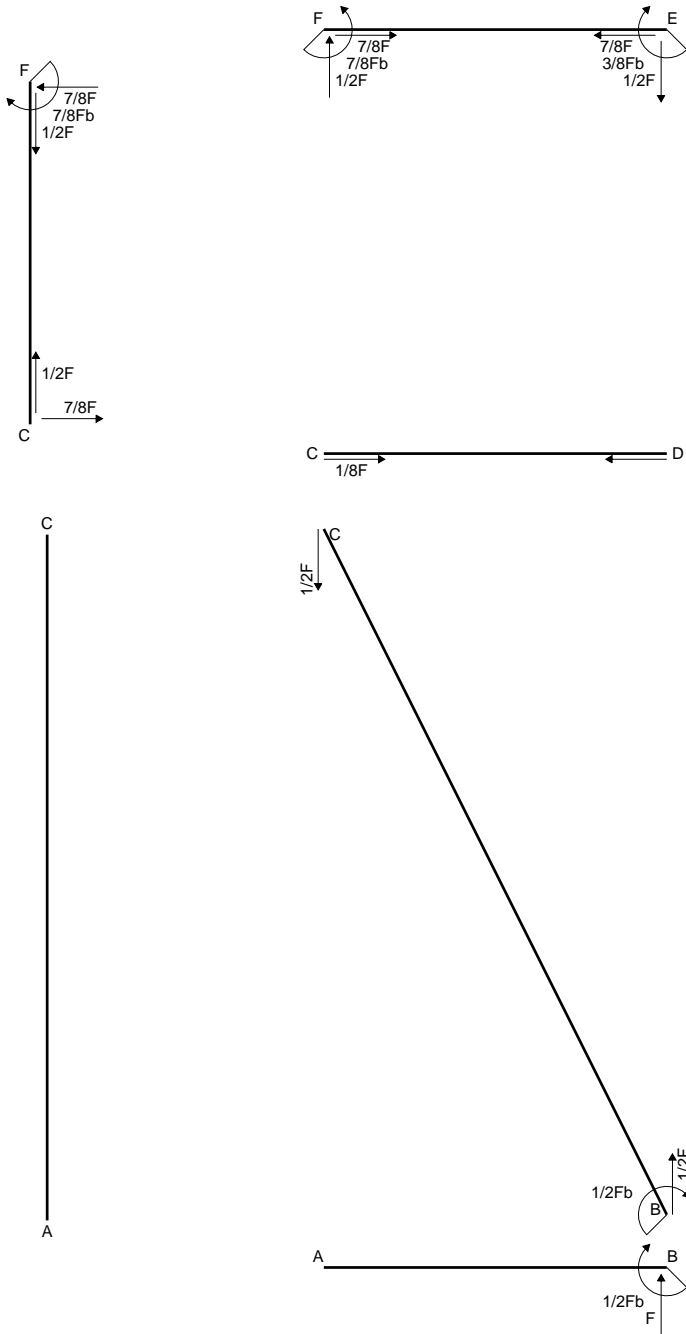

← ⊕ → F

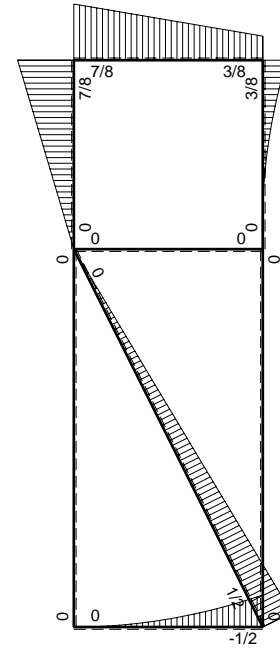

⊕ ⊖ F_b

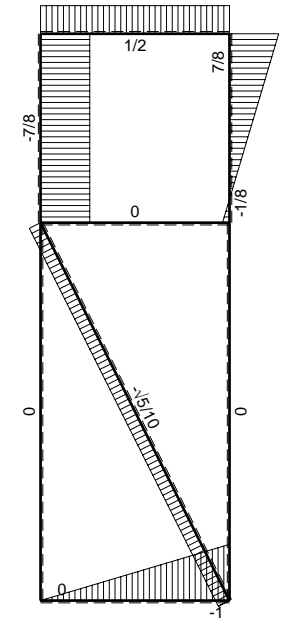

↑ ⊕ ↓ F

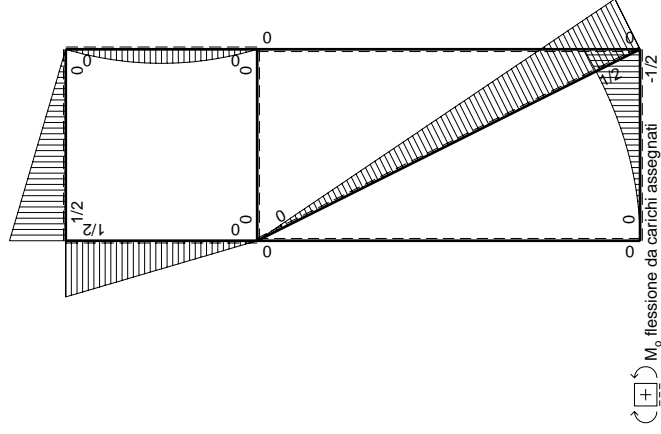
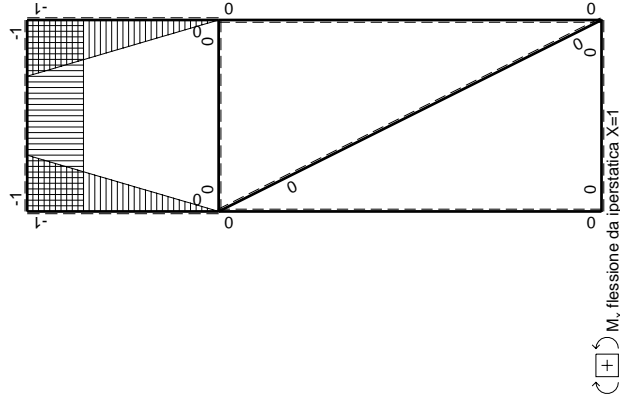
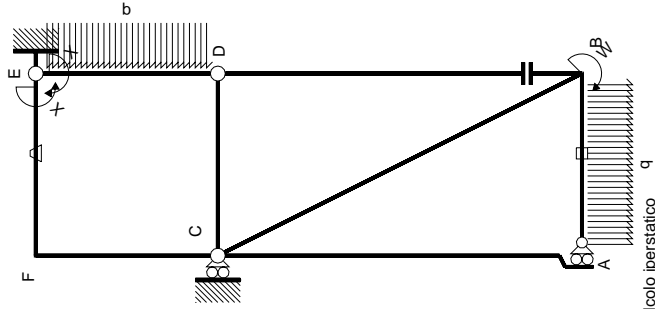

Quadro contributi PLV per iperstatica $X=W_{EF}$

\rightarrow	$M^k(x)$	$M^0(x)$	θ	$M^x M_0$	$M^x \theta$	$M^x M_x$	$\int M^x (M_0/EJ + \theta) dx$	$\int M^x M_x / E J dx$
AB B	0	$-1/2qx^2$	0	0	0	0	0	0
BA B	0	$1/2Fb - Fx + 1/2qx^2$	0	0	0	0	0	0
BC $\sqrt{5}b$	0	$1/2Fb - \sqrt{5}/10Fx$	0	0	0	0	0	0
AC 2b	0	0	0	0	0	0	0	0
CA 2b	0	0	0	0	0	0	0	0
DB 2b	0	0	0	0	0	0	0	0
BD 2b	0	0	0	0	0	0	0	0
DE B	$-x/b$	$-1/2Fx + 1/2qx^2$	0	$1/2F^2x^2/b - 1/2qx^3/b$	0	x^2/b^2	$(1/2+4+0)Fb^2/EJ$	$1/3xb/EJ$
ED B	$1-x/b$	$1/2Fx - 1/2qx^2$	0	$1/2Fx - Fx^2/b + 1/2qx^3/b$	0	$1-2x/b + x^2/b^2$	$(1/2+4+0)Fb^2/EJ$	$1/3xb/EJ$
CD B	0	0	0	0	0	0	0	0
DC B	0	0	0	0	0	0	0	0
EF B	-1	$1/2Fx$	$-Fb/EJ$	$-1/2Fx$	Fb/EJ	1	$(-1/4+1)Fb^2/EJ$	xb/EJ
FE B	1	$-1/2Fb + 1/2Fx$	Fb/EJ	$-1/2Fb + 1/2Fx$	Fb/EJ	1	$(-1/4+1)Fb^2/EJ$	xb/EJ
FC B	$-1+x/b$	$1/2Fb - 1/2Fx$	0	$-1/2Fb + Fx - 1/2Fx^2/b$	0	$1-2x/b + x^2/b^2$	$(-1/6+0)Fb^2/EJ$	$1/3xb/EJ$
CF B	x/b	$-1/2Fx$	0	$-1/2Fx^2/b$	0	x^2/b^2	$(-1/6+0)Fb^2/EJ$	$1/3xb/EJ$
totali							$5/8Fb^2/EJ$	$5/3xb/EJ$
								$-3/8Fb$

Sviluppi di calcolo iperstatica

$$L_{DE}^{xx} = \int_0^b (x^2/b^2) 1/EJ dx = [1/3 x^3/b^2]_0^b 1/EJ$$

$$= (1/3 b) 1/EJ = 1/3 b/EJ$$

$$L_{ED}^{xx} = \int_0^b (1 - 2x/b + x^2/b^2) 1/EJ dx = [x - x^2/b + 1/3 x^3/b^2]_0^b 1/EJ$$

$$= (b - b + 1/3 b) 1/EJ = 1/3 b/EJ$$

$$L_{EF}^{xx} = \int_0^b (1) 1/EJ dx = [x]_0^b 1/EJ$$

$$= (b) 1/EJ = b/EJ$$

$$L_{FE}^{xx} = \int_0^b (1) 1/EJ dx = [x]_0^b 1/EJ$$

$$= (b) 1/EJ = b/EJ$$

$$L_{FC}^{xx} = \int_0^b (1 - 2x/b + x^2/b^2) 1/EJ dx = [x - x^2/b + 1/3 x^3/b^2]_0^b 1/EJ$$

$$= (b - b + 1/3 b) 1/EJ = 1/3 b/EJ$$

$$L_{CF}^{xx} = \int_0^b (x^2/b^2) 1/EJ dx = [1/3 x^3/b^2]_0^b 1/EJ$$

$$= (1/3 b) 1/EJ = 1/3 b/EJ$$

$$L_{DE}^{xo} = \int_0^b (1/2 x^2/b^2 - 1/2 x^3/b^3) Fb 1/EJ dx = [1/6 x^3/b^2 - 1/8 x^4/b^3]_0^b Fb 1/EJ$$

$$= (1/6 b - 1/8 b) Fb 1/EJ = 1/24 Fb^2/EJ$$

$$L_{ED}^{xo} = \int_0^b (1/2 x/b - x^2/b^2 + 1/2 x^3/b^3) Fb 1/EJ dx = [1/4 x^2/b - 1/3 x^3/b^2 + 1/8 x^4/b^3]_0^b Fb 1/EJ$$

$$= (1/4 b - 1/3 b + 1/8 b) Fb 1/EJ = 1/24 Fb^2/EJ$$

$$L_{EF}^{xo} = \int_0^b (-1/2 x/b) Fb 1/EJ dx + \int_0^b (1) \theta dx = [-1/4 x^2/b]_0^b Fb 1/EJ + [x]_0^b \theta$$

$$= (-1/4 b) Fb 1/EJ + (b) \theta = 3/4 Fb^2/EJ$$

$$L_{FE}^{xo} = \int_0^b (-1/2 + 1/2 x/b) Fb 1/EJ dx + \int_0^b (-1) \theta dx = [-1/2 x + 1/4 x^2/b]_0^b Fb 1/EJ + [-x]_0^b \theta$$

$$= (-1/2 b + 1/4 b) Fb 1/EJ + (-b) \theta = 3/4 Fb^2/EJ$$

$$L_{FC}^{xo} = \int_0^b (-1/2 + x/b - 1/2 x^2/b^2) Fb 1/EJ dx = [-1/2 x + 1/2 x^2/b - 1/6 x^3/b^2]_0^b Fb 1/EJ$$

$$= (-1/2 b + 1/2 b - 1/6 b) Fb 1/EJ = -1/6 Fb^2/EJ$$

$$L_{CF}^{xo} = \int_0^b (-1/2 x^2/b^2) Fb 1/EJ dx = [-1/6 x^3/b^2]_0^b Fb 1/EJ$$

$$= (-1/6 b) Fb 1/EJ = -1/6 Fb^2/EJ$$

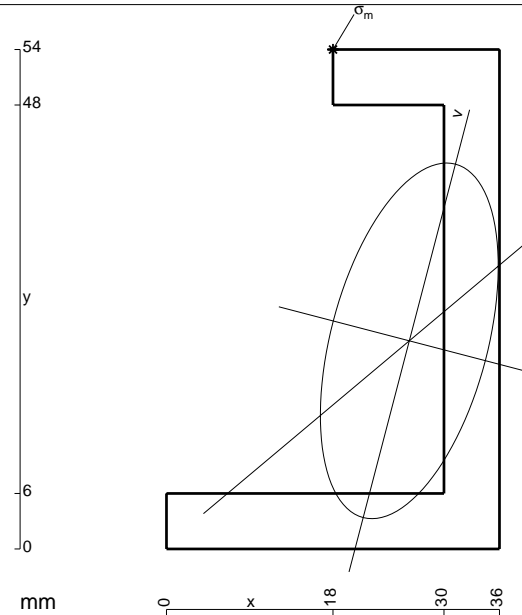

- A = 576. mm²
- J_x = 212976. mm⁴
- J_y = 53244. mm⁴
- J_{xy} = 44712. mm⁴
- J_u = 224640. mm⁴
- J_v = 41580. mm⁴
- α = arctg(2J_{xy}/(J_y-J_x))/2 = -.2552
- c = cos α = .9676
- s = sin α = -.2524
- x_g = 26.25 mm
- y_g = 22.5 mm
- N = -2100. N
- T_y = 1200. N
- M_x = 1029000. Nmm
- x_m = 18. mm
- y_m = 54. mm
- u_m = -15.93 mm
- v_m = 28.4 mm
- σ_m = N/A - Mcv/J_u - Msu/J_v = -229.1 N/mm²

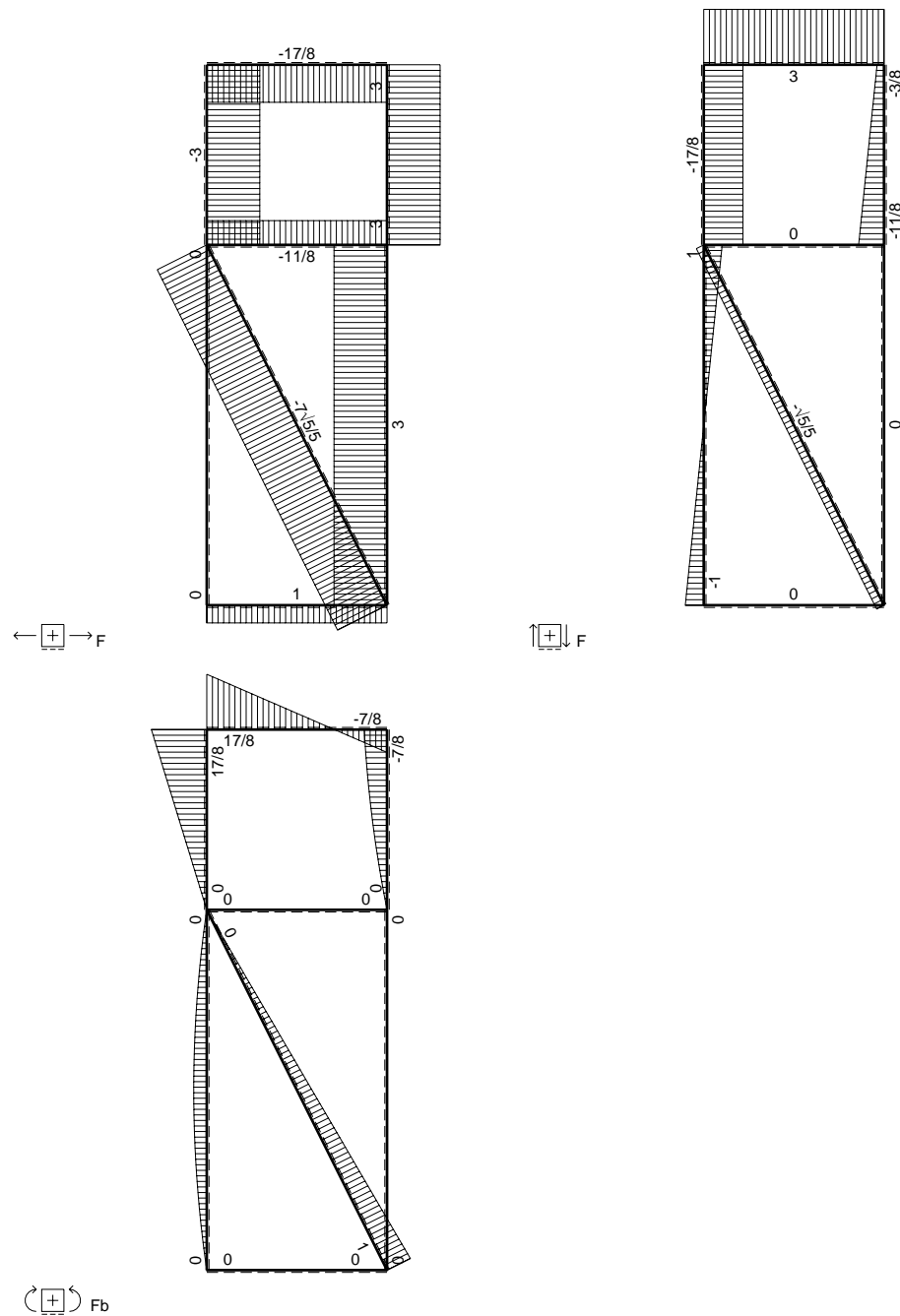
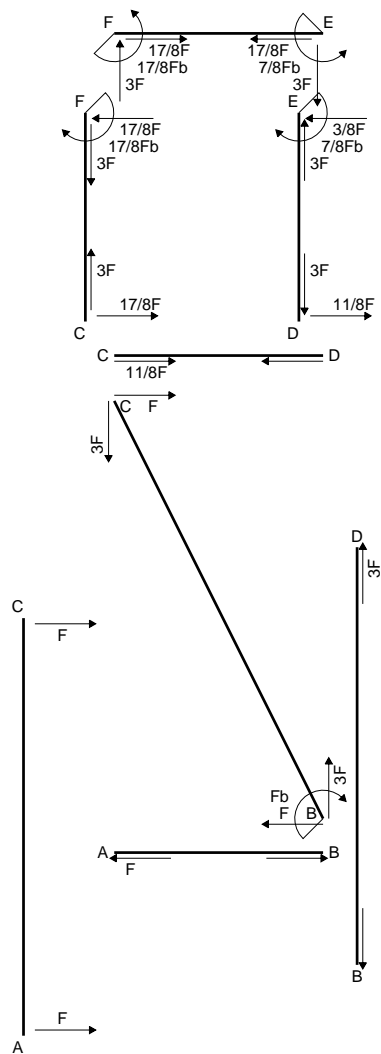

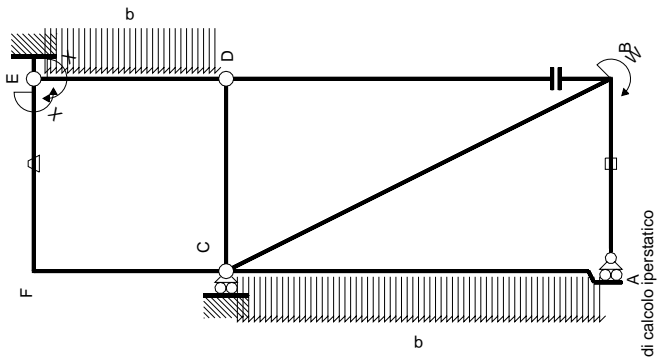

M_0 flessione da carichi assegnati

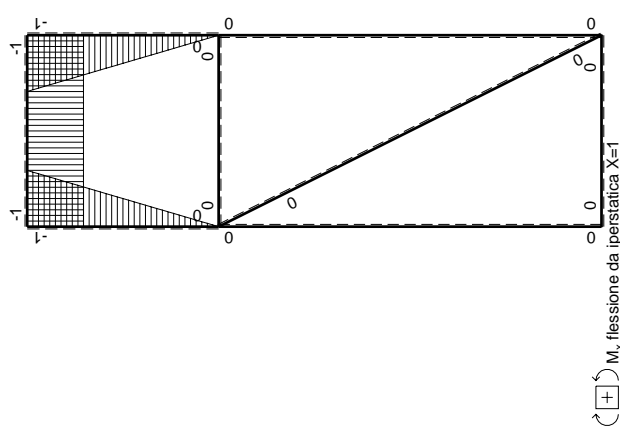

Quadro contributi PLV per iperstatica $X=W_{EF}$		$M^x(x)$	$M^0(x)$	θ	$M^x M^0$	$M^x \theta$	$M^x M^x$	$\int M^x(M^0/EJ+\theta)dx$	$\int M^x M^x/EJ dx$	
AB b	0	0	0	0	0	0	0	0	0	
BA b	0	0	0	0	0	0	0	0	0	
BC $\sqrt{5}b$	0	$Fb-\sqrt{5}/5Fx$	0	0	0	0	0	0	0	
AC 2b	0	$-Fx+1/2qx^2$	0	0	0	0	0	0	0	
CA 2b	0	$Fx-1/2qx^2$	0	0	0	0	0	0	0	
DB 2b	0	0	0	0	0	0	0	0	0	
BD 2b	0	0	0	0	0	0	0	0	0	
DE b	$-x/b$	$-1/2Fx+1/2qx^2$	0	$1/2Fx^2/b-1/2qx^3/b$	0	0	x^2/b^2	$(1/24+0)Fb^2/EJ$	$1/3Xb/EJ$	
ED b	$1-x/b$	$1/2Fx-1/2qx^2$	0	$1/2Fx-Fx^2/b+1/2qx^3/b$	0	0	$1-2x/b+x^2/b^2$	$(1/24+0)Fb^2/EJ$	$1/3Xb/EJ$	
CD b	0	0	0	0	0	0	0	0	0	
DC b	0	0	0	0	0	0	0	0	0	
EF b	-1	$3Fx$	$-Fb/EJ$	$-3Fx$	Fb/EJ	Fb/EJ	1	$(-3/2+1)Fb^2/EJ$	Xb/EJ	
FE b	1	$-3Fb+3Fx$	Fb/EJ	$-3Fb+3Fx$	Fb/EJ	Fb/EJ	1	$(-3/2+1)Fb^2/EJ$	Xb/EJ	
FC b	$-1+x/b$	$3Fb-3Fx$	0	$-3Fb+6Fx-3Fx^2/b$	0	0	$1-2x/b+x^2/b^2$	$(-1+0)Fb^2/EJ$	$1/3Xb/EJ$	
CF b	x/b	$-3Fx$	0	$-3Fx^2/b$	0	0	x^2/b^2	$(-1+0)Fb^2/EJ$	$1/3Xb/EJ$	
totali								$-35/24Fb^2/EJ$	$5/3Xb/EJ$	
		iperstatica $X=W_{EF}$								
		$7/8Fb$								

Sviluppi di calcolo iperstatica

$$L_{DE}^{xx} = \int_0^b (x^2/b^2) 1/EJ dx = [1/3 x^3/b^2]_0^b 1/EJ$$

$$= (1/3 b) 1/EJ = 1/3 b/EJ$$

$$L_{ED}^{xx} = \int_0^b (1 - 2x/b + x^2/b^2) 1/EJ dx = [x - x^2/b + 1/3 x^3/b^2]_0^b 1/EJ$$

$$= (b - b + 1/3 b) 1/EJ = 1/3 b/EJ$$

$$L_{EF}^{xx} = \int_0^b (1) 1/EJ dx = [x]_0^b 1/EJ$$

$$= (b) 1/EJ = b/EJ$$

$$L_{FE}^{xx} = \int_0^b (1) 1/EJ dx = [x]_0^b 1/EJ$$

$$= (b) 1/EJ = b/EJ$$

$$L_{FC}^{xx} = \int_0^b (1 - 2x/b + x^2/b^2) 1/EJ dx = [x - x^2/b + 1/3 x^3/b^2]_0^b 1/EJ$$

$$= (b - b + 1/3 b) 1/EJ = 1/3 b/EJ$$

$$L_{CF}^{xx} = \int_0^b (x^2/b^2) 1/EJ dx = [1/3 x^3/b^2]_0^b 1/EJ$$

$$= (1/3 b) 1/EJ = 1/3 b/EJ$$

$$L_{DE}^{xo} = \int_0^b (1/2 x^2/b^2 - 1/2 x^3/b^3) Fb 1/EJ dx = [1/6 x^3/b^2 - 1/8 x^4/b^3]_0^b Fb 1/EJ$$

$$= (1/6 b - 1/8 b) Fb 1/EJ = 1/24 Fb^2/EJ$$

$$L_{ED}^{xo} = \int_0^b (1/2 x/b - x^2/b^2 + 1/2 x^3/b^3) Fb 1/EJ dx = [1/4 x^2/b - 1/3 x^3/b^2 + 1/8 x^4/b^3]_0^b Fb 1/EJ$$

$$= (1/4 b - 1/3 b + 1/8 b) Fb 1/EJ = 1/24 Fb^2/EJ$$

$$L_{EF}^{xo} = \int_0^b (-3x/b) Fb 1/EJ dx + \int_0^b (1) \theta dx = [-3/2 x^2/b]_0^b Fb 1/EJ + [x]_0^b \theta$$

$$= (-3/2 b) Fb 1/EJ + (b) \theta = -1/2 Fb^2/EJ$$

$$L_{FE}^{xo} = \int_0^b (-3 + 3x/b) Fb 1/EJ dx + \int_0^b (-1) \theta dx = [-3x + 3/2 x^2/b]_0^b Fb 1/EJ + [-x]_0^b \theta$$

$$= (-3b + 3/2 b) Fb 1/EJ + (-b) \theta = -1/2 Fb^2/EJ$$

$$L_{FC}^{xo} = \int_0^b (-3 + 6x/b - 3x^2/b^2) Fb 1/EJ dx = [-3x + 3x^2/b - x^3/b^2]_0^b Fb 1/EJ$$

$$= (-3b + 3b - b) Fb 1/EJ = - Fb^2/EJ$$

$$L_{CF}^{xo} = \int_0^b (-3x^2/b^2) Fb 1/EJ dx = [-x^3/b^2]_0^b Fb 1/EJ$$

$$= (-b) Fb 1/EJ = - Fb^2/EJ$$

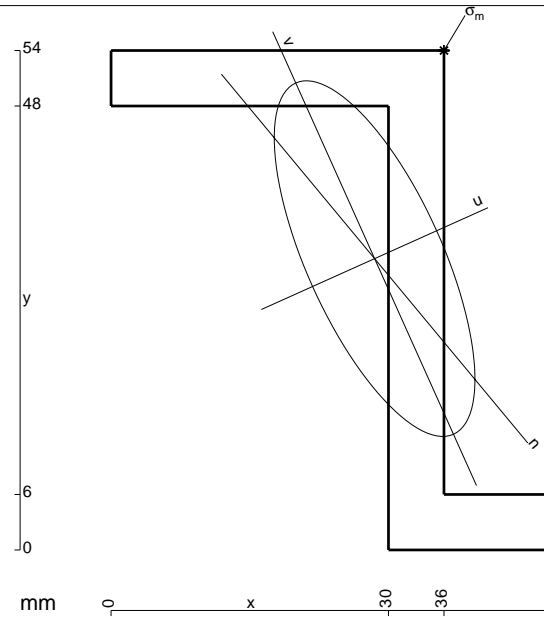

- A = 576. mm²
- J_x = 212976. mm⁴
- J_y = 67824. mm⁴
- J_{xy} = -81648. mm⁴
- J_u = 249641. mm⁴
- J_v = 31159. mm⁴
- α = arctg(2J_{xy}/(J_y-J_x))/2 = .4221
- c = cos α = .9122
- s = sin α = .4097
- x_g = 28.5 mm
- y_g = 31.5 mm
- N = -2280. N
- T_y = -1615. N
- M_x = 855950. Nmm
- x_m = 36. mm
- y_m = 54. mm
- u_m = 16.06 mm
- v_m = 17.45 mm
- σ_m = N/A - Mcv/J_v - Msu/J_u = -239.3 N/mm²

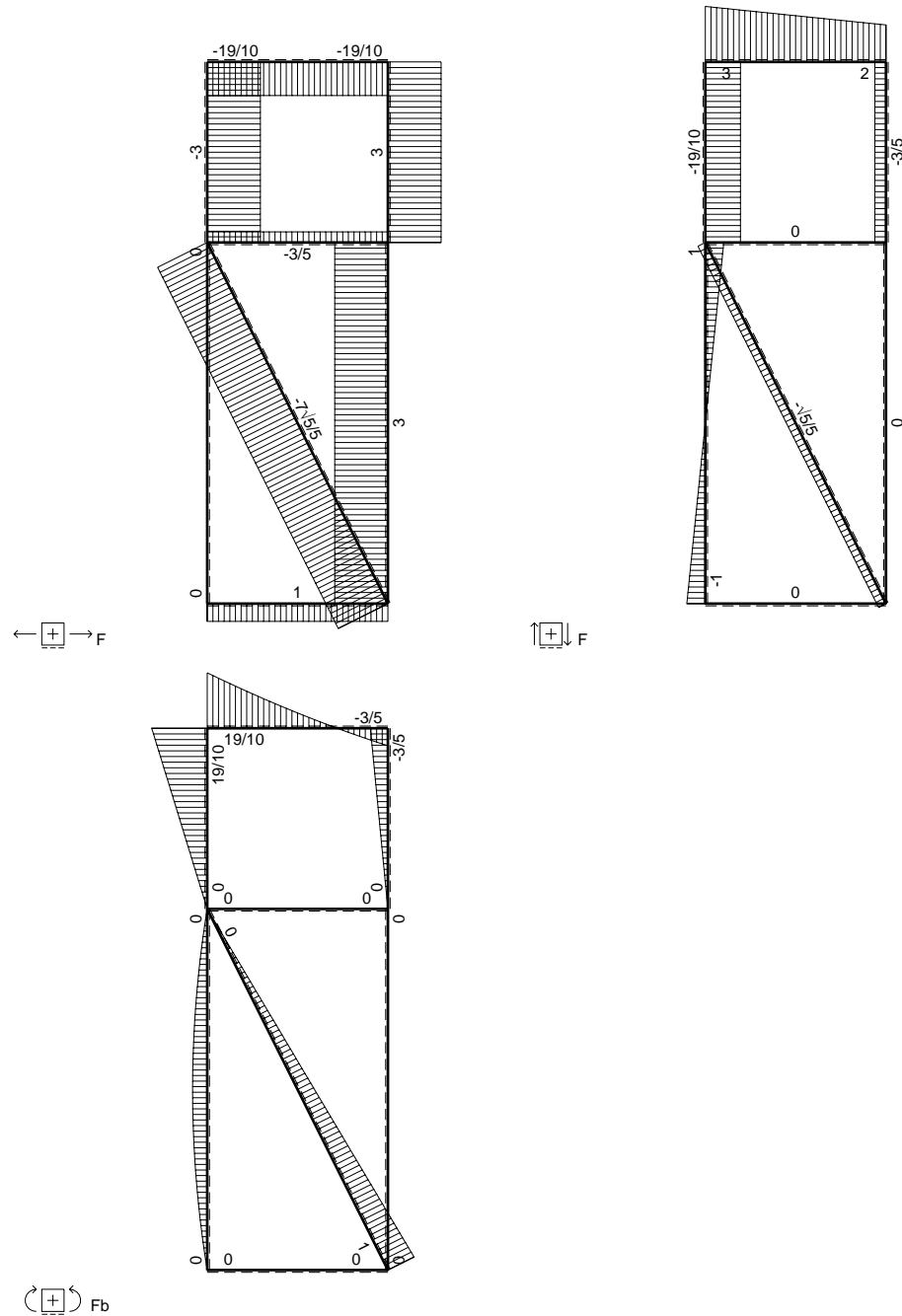
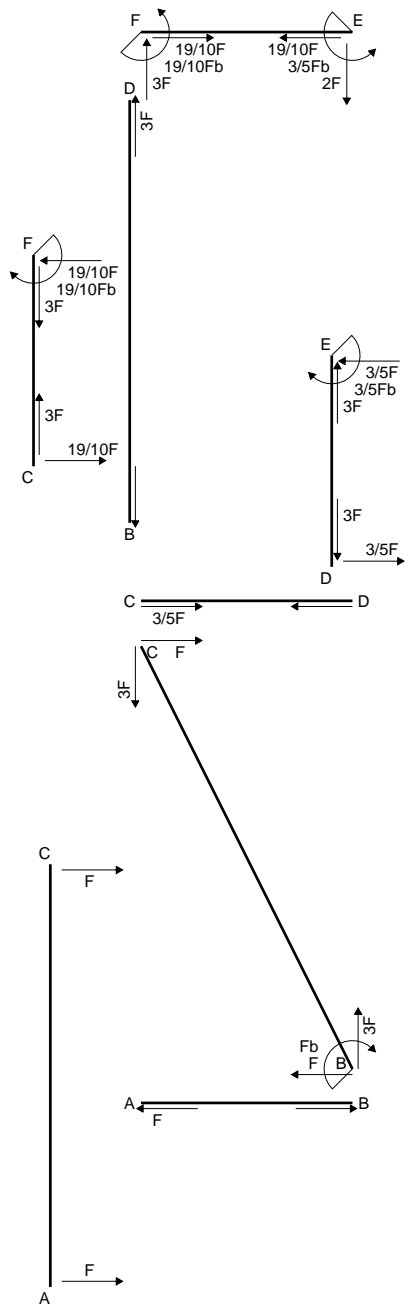

$\left[\begin{matrix} + \\ + \end{matrix} \right] F_b$

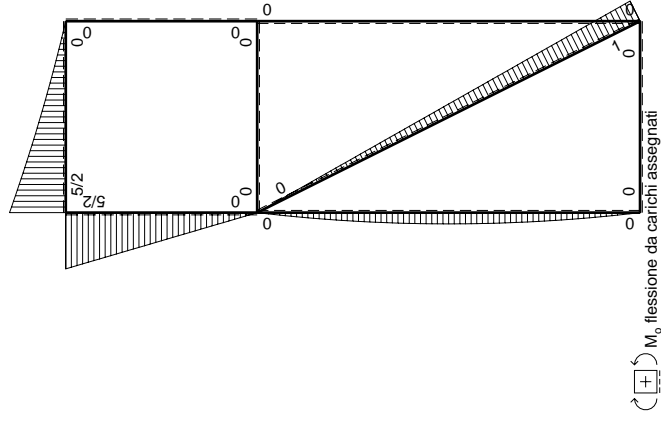
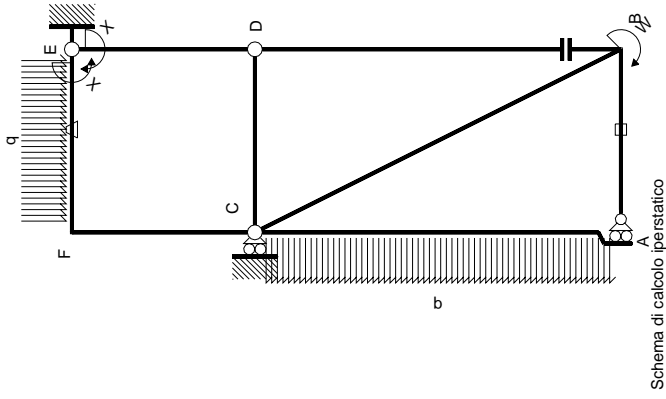

Quadro contribuiti PLV per iperstatica $X=W_{EF}$

\leftarrow	$M^x(x)$	$M^0(x)$	θ	$M^x M_0$	$M^x \theta$	$M^x M_x$	$\int M^x(M_0/EJ+\theta)dx$	$\int M^x M_x/EJdx$
AB b	0	0	0	0	0	0	0	0
BA b	0	0	0	0	0	0	0	0
BC $\sqrt{5}b$	0	$Fb-\sqrt{5}/5Fx$	0	0	0	0	0	0
AC 2b	0	$-Fx+1/2qx^2$	0	0	0	0	0	0
CA 2b	0	$Fx-1/2qx^2$	0	0	0	0	0	0
DB 2b	0	0	0	0	0	0	0	0
BD 2b	0	0	0	0	0	0	0	0
DE b	$-x/b$	0	0	0	0	0	0	0
ED b	$1-x/b$	0	0	0	0	0	0	0
CD b	0	0	0	0	0	0	0	0
DC b	0	0	0	0	0	0	0	0
EF b	-1	$2Fx+1/2qx^2$	$-Fb/EJ$	$-2Fx-1/2Fx^2/b$	Fb/EJ	1	1	Xb/EJ
FE b	1	$-5/2Fb+3Fx-1/2qx^2$	Fb/EJ	$-5/2Fb+3Fx-1/2Fx^2/b$	Fb/EJ	1	1	Xb/EJ
FC b	$-1+x/b$	$5/2Fb-5/2Fx$	0	$-5/2Fb+5Fx-5/2Fx^2/b$	0	$1-2x/b+x^2/b^2$	0	$1/3Xb/EJ$
CF b	x/b	$-5/2Fx$	0	$-5/2Fx^2/b$	0	x^2/b^2	0	$1/3Xb/EJ$
totali								$5/3Xb/EJ$
								$-Fb^2/EJ$
								$3/5Fb$

Sviluppi di calcolo iperstatica

$$L_{DE}^{xx} = \int_0^b (x^2/b^2) 1/EJ dx = [1/3 x^3/b^2]_0^b 1/EJ$$

$$= (1/3 b) 1/EJ = 1/3 b/EJ$$

$$L_{ED}^{xx} = \int_0^b (1 - 2x/b + x^2/b^2) 1/EJ dx = [x - x^2/b + 1/3 x^3/b^2]_0^b 1/EJ$$

$$= (b - b + 1/3 b) 1/EJ = 1/3 b/EJ$$

$$L_{EF}^{xx} = \int_0^b (1) 1/EJ dx = [x]_0^b 1/EJ$$

$$= (b) 1/EJ = b/EJ$$

$$L_{FE}^{xx} = \int_0^b (1) 1/EJ dx = [x]_0^b 1/EJ$$

$$= (b) 1/EJ = b/EJ$$

$$L_{FC}^{xx} = \int_0^b (1 - 2x/b + x^2/b^2) 1/EJ dx = [x - x^2/b + 1/3 x^3/b^2]_0^b 1/EJ$$

$$= (b - b + 1/3 b) 1/EJ = 1/3 b/EJ$$

$$L_{CF}^{xx} = \int_0^b (x^2/b^2) 1/EJ dx = [1/3 x^3/b^2]_0^b 1/EJ$$

$$= (1/3 b) 1/EJ = 1/3 b/EJ$$

$$L_{EF}^{xo} = \int_0^b (-2x/b - 1/2 x^2/b^2) Fb 1/EJ dx + \int_0^b (1) \theta dx = [-x^2/b - 1/6 x^3/b^2]_0^b Fb 1/EJ + [x]_0^b \theta$$

$$= (-b - 1/6 b) Fb 1/EJ + (b) \theta = -1/6 Fb^2/EJ$$

$$L_{FE}^{xo} = \int_0^b (-5/2 + 3x/b - 1/2 x^2/b^2) Fb 1/EJ dx + \int_0^b (-1) \theta dx$$

$$= [-5/2 x + 3/2 x^2/b - 1/6 x^3/b^2]_0^b Fb 1/EJ + [-x]_0^b \theta$$

$$= (-5/2 b + 3/2 b - 1/6 b) Fb 1/EJ + (-b) \theta = -1/6 Fb^2/EJ$$

$$L_{FC}^{xo} = \int_0^b (-5/2 + 5x/b - 5/2 x^2/b^2) Fb 1/EJ dx = [-5/2 x + 5/2 x^2/b - 5/6 x^3/b^2]_0^b Fb 1/EJ$$

$$= (-5/2 b + 5/2 b - 5/6 b) Fb 1/EJ = -5/6 Fb^2/EJ$$

$$L_{CF}^{xo} = \int_0^b (-5/2 x^2/b^2) Fb 1/EJ dx = [-5/6 x^3/b^2]_0^b Fb 1/EJ$$

$$= (-5/6 b) Fb 1/EJ = -5/6 Fb^2/EJ$$

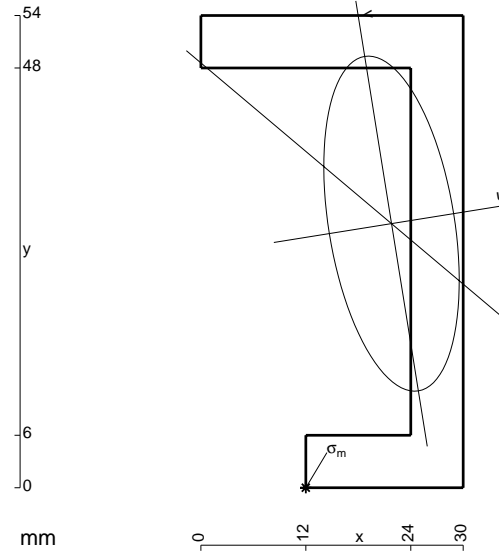

$$A = 540. \text{ mm}^2$$

$$J_x = 198266. \text{ mm}^4$$

$$J_y = 32378. \text{ mm}^4$$

$$J_{xy} = -27302. \text{ mm}^4$$

$$J_u = 202644. \text{ mm}^4$$

$$J_v = 28000. \text{ mm}^4$$

$$\alpha = \text{artg}(2J_{xy}/(J_y - J_x))/2 = .1590$$

$$c = \cos \alpha = .9874$$

$$s = \sin \alpha = .1583$$

$$x_g = 21.8 \text{ mm}$$

$$y_g = 30.2 \text{ mm}$$

$$N = -1615. \text{ N}$$

$$T_y = 2550. \text{ N}$$

$$M_x = 920550. \text{ Nmm}$$

$$x_m = 12. \text{ mm}$$

$$u_m = -14.46 \text{ mm}$$

$$v_m = -28.27 \text{ mm}$$

$$\sigma_m = N/A - Mcv/J_u - Msu/J_v = 199.1 \text{ N/mm}^2$$

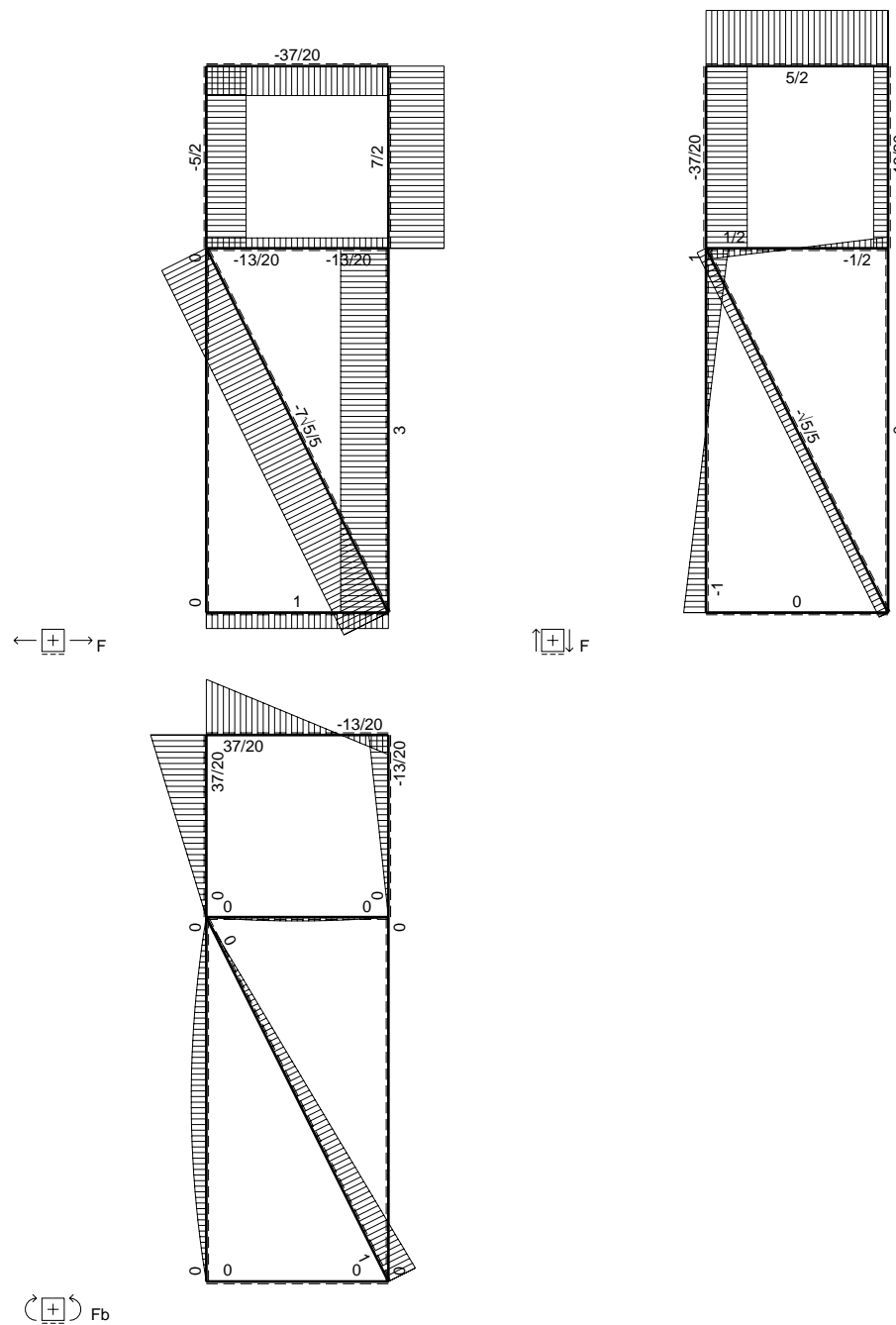
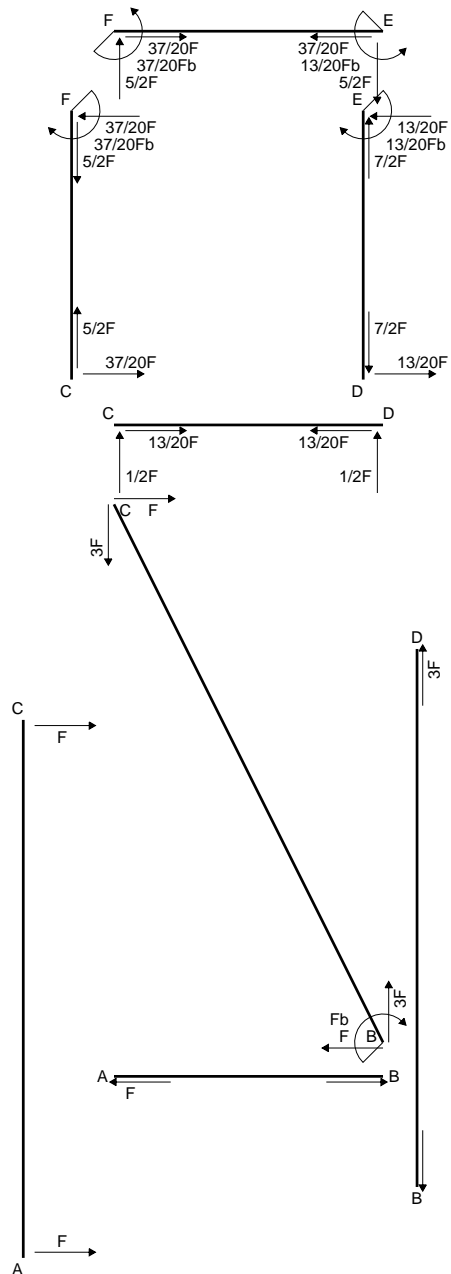

⊕ Fb

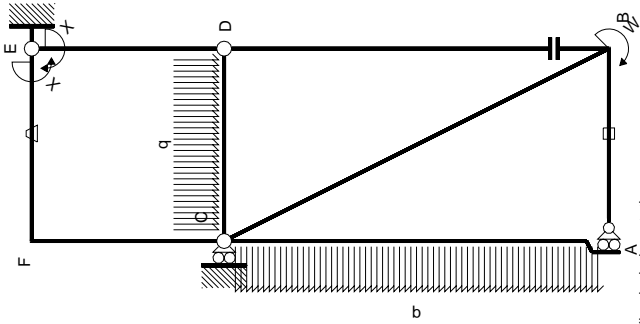

Schema di calcolo iperstatico

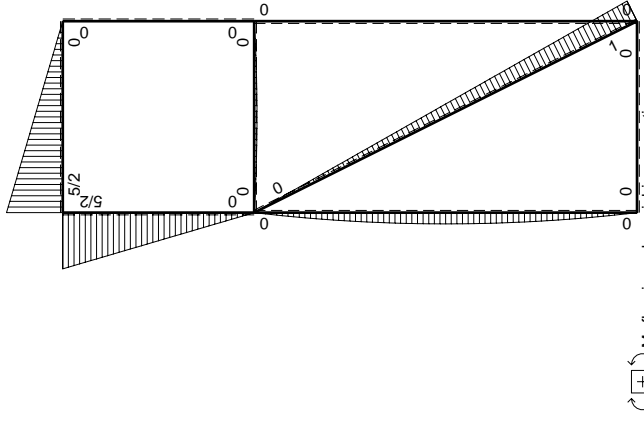

M_0 flessione da carichi assegnati

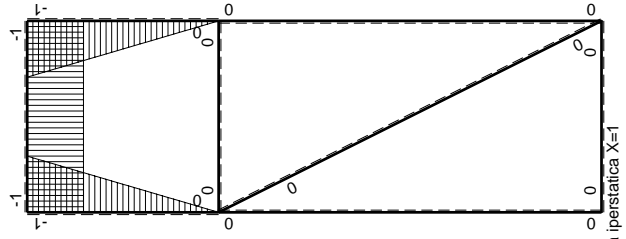

M_x flessione da iperstatica X=1

Quadro contributi PLV per iperstatica X=W_{EP}

←	M ^x (x)	M ^o (x)	θ	M ^x M ₀	M ^x θ	M ^x M _x	∫M ^x (M ₀ /EI+θ)dx	∫M ^x M _x /EIdx
AB b	0	0	0	0	0	0	0+0	0
BA b	0	0	0	0	0	0	0	0
BC √5b	0	Fb-√5/5Fx	0	0	0	0	0	0
AC 2b	0	-Fx+1/2qx ²	0	0	0	0	0+0	0
CA 2b	0	Fx-1/2qx ²	0	0	0	0	0+0	0
DB 2b	0	0	0	0	0	0	0+0	0
BD 2b	0	0	0	0	0	0	0+0	0
DE b	-x/b	0	0	0	0	0	0+0	1/3Xb/EJ
ED b	1-x/b	0	0	0	0	0	0+0	1/3Xb/EJ
CD b	0	1/2Fx-1/2qx ²	0	0	0	0	0	0
DC b	0	-1/2Fx+1/2qx ²	0	0	0	0	0+0	0
EF b	-1	5/2Fx	-Fb/EJ	-5/2Fx	Fb/EJ	1	(-5/4+1)Fb ² /EJ	Xb/EJ
FE b	1	-5/2Fb+5/2Fx	Fb/EJ	-5/2Fb+5/2Fx	Fb/EJ	1	(-5/4+1)Fb ² /EJ	Xb/EJ
FC b	-1+x/b	5/2Fb-5/2Fx	0	-5/2Fb+5Fx-5/2Fx ² /b	0	1-2x/b+x ² /b ²	(-5/6+0)Fb ² /EJ	1/3Xb/EJ
CF b	x/b	-5/2Fx	0	-5/2Fx ² /b	0	x ² /b ²	(-5/6+0)Fb ² /EJ	5/3Xb/EJ
totali							-13/12Fb ² /EJ	5/3Xb/EJ
							13/20Fb	

iperstatica X=W_{EP}

Sviluppi di calcolo iperstatica

$$L_{DE}^{xx} = \int_0^b (x^2/b^2) 1/EJ dx = [1/3 x^3/b^2]_0^b 1/EJ$$

$$= (1/3 b) 1/EJ = 1/3 b/EJ$$

$$L_{ED}^{xx} = \int_0^b (1 - 2x/b + x^2/b^2) 1/EJ dx = [x - x^2/b + 1/3 x^3/b^2]_0^b 1/EJ$$

$$= (b - b + 1/3 b) 1/EJ = 1/3 b/EJ$$

$$L_{EF}^{xx} = \int_0^b (1) 1/EJ dx = [x]_0^b 1/EJ$$

$$= (b) 1/EJ = b/EJ$$

$$L_{FE}^{xx} = \int_0^b (1) 1/EJ dx = [x]_0^b 1/EJ$$

$$= (b) 1/EJ = b/EJ$$

$$L_{FC}^{xx} = \int_0^b (1 - 2x/b + x^2/b^2) 1/EJ dx = [x - x^2/b + 1/3 x^3/b^2]_0^b 1/EJ$$

$$= (b - b + 1/3 b) 1/EJ = 1/3 b/EJ$$

$$L_{CF}^{xx} = \int_0^b (x^2/b^2) 1/EJ dx = [1/3 x^3/b^2]_0^b 1/EJ$$

$$= (1/3 b) 1/EJ = 1/3 b/EJ$$

$$L_{EF}^{xo} = \int_0^b (-5/2 x/b) Fb 1/EJ dx + \int_0^b (1) \theta dx = [-5/4 x^2/b]_0^b Fb 1/EJ + [x]_0^b \theta$$

$$= (-5/4 b) Fb 1/EJ + (b) \theta = -1/4 Fb^2/EJ$$

$$L_{FE}^{xo} = \int_0^b (-5/2 + 5/2 x/b) Fb 1/EJ dx + \int_0^b (-1) \theta dx = [-5/2 x + 5/4 x^2/b]_0^b Fb 1/EJ + [-x]_0^b \theta$$

$$= (-5/2 b + 5/4 b) Fb 1/EJ + (-b) \theta = -1/4 Fb^2/EJ$$

$$L_{FC}^{xo} = \int_0^b (-5/2 + 5x/b - 5/2 x^2/b^2) Fb 1/EJ dx = [-5/2 x + 5/2 x^2/b - 5/6 x^3/b^2]_0^b Fb 1/EJ$$

$$= (-5/2 b + 5/2 b - 5/6 b) Fb 1/EJ = -5/6 Fb^2/EJ$$

$$L_{CF}^{xo} = \int_0^b (-5/2 x^2/b^2) Fb 1/EJ dx = [-5/6 x^3/b^2]_0^b Fb 1/EJ$$

$$= (-5/6 b) Fb 1/EJ = -5/6 Fb^2/EJ$$

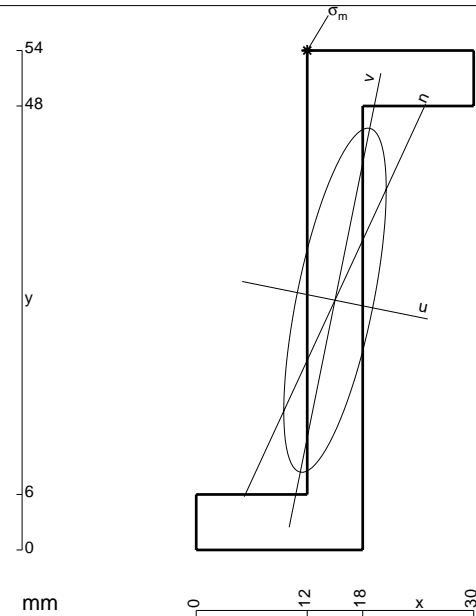

- A = 468. mm²
- J_x = 162108. mm⁴
- J_y = 14364. mm⁴
- J_{xy} = 31104. mm⁴
- J_u = 168389. mm⁴
- J_v = 8083. mm⁴
- α = arctg(2J_{xy}/(J_y-J_x))/2 = -.1993
- c = cos α = .9802
- s = sin α = -.1979
- x_g = 15. mm
- y_g = 27. mm
- N = -1300. N
- T_y = -962. N
- M_x = 577200. Nmm
- x_m = 12. mm
- y_m = 54. mm
- u_m = -8.285 mm
- v_m = 25.87 mm
- σ_m = N/A - Mcv/J_u - Msu/J_v = -206.8 N/mm²

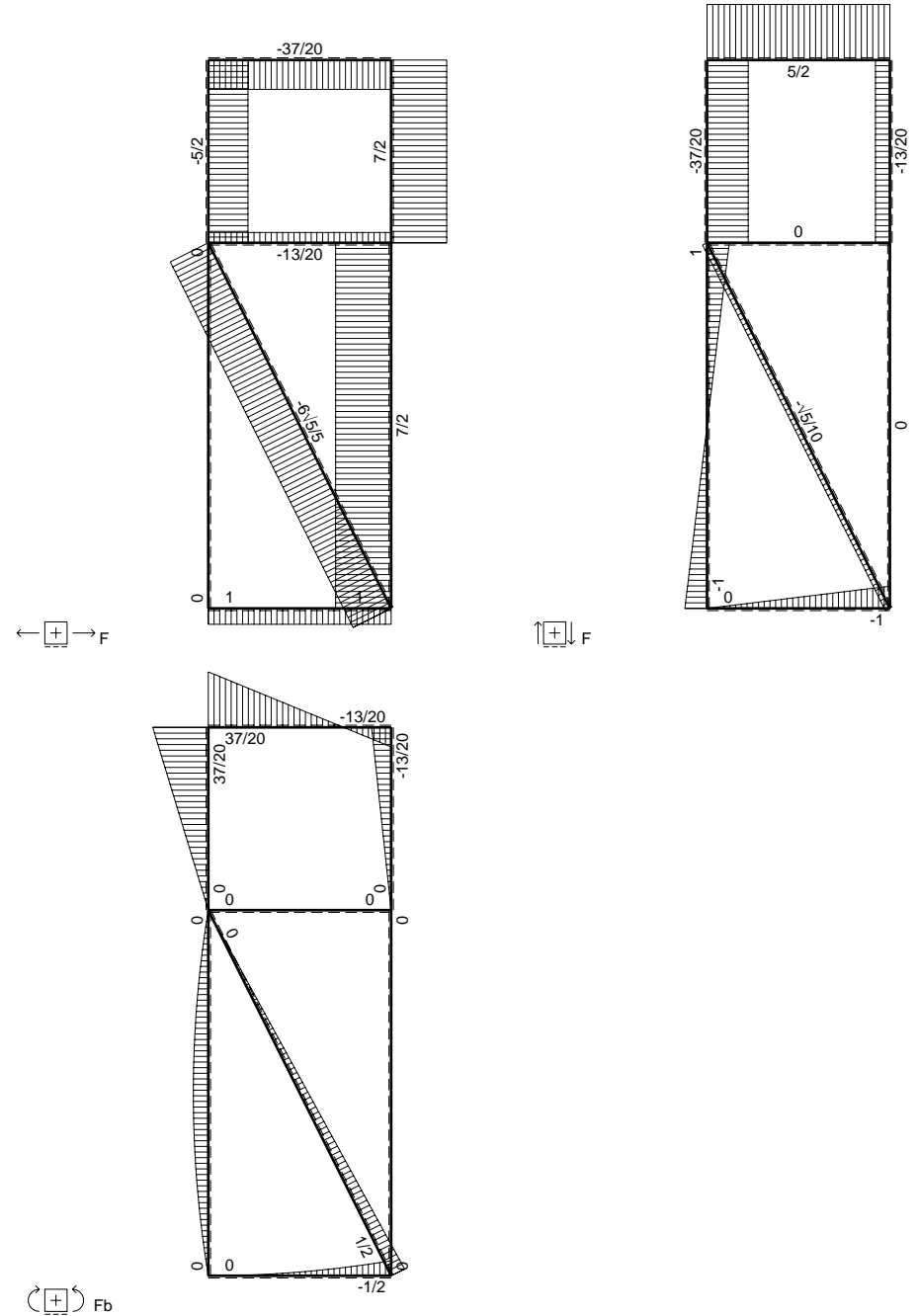
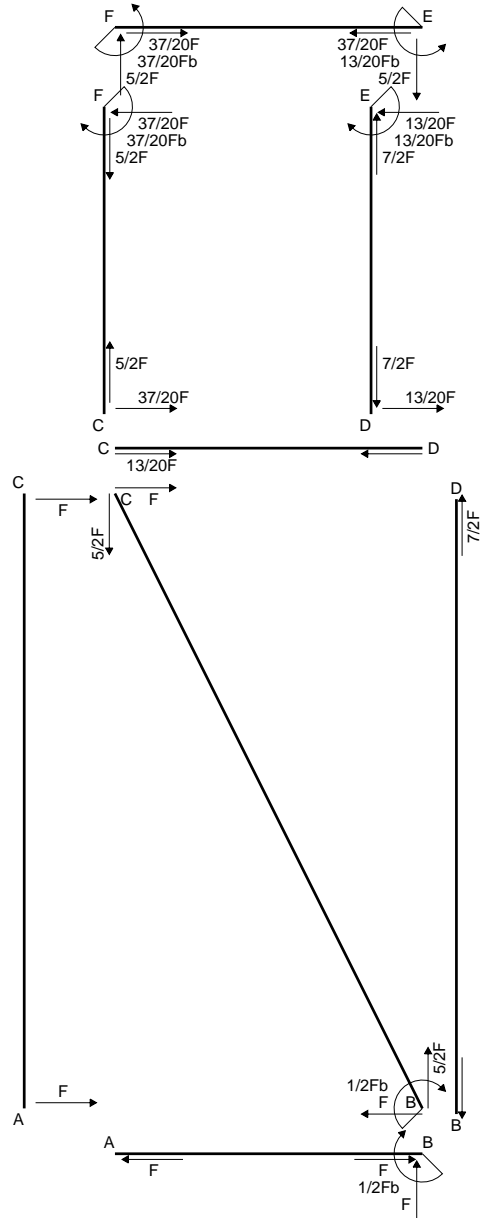

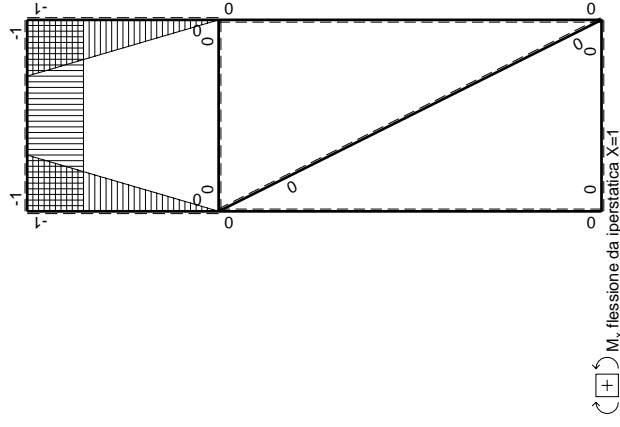
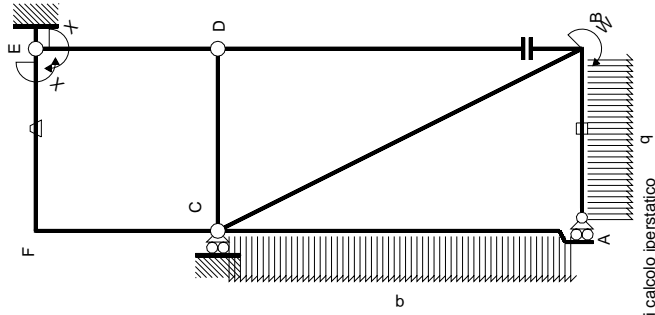

Quadro contributi PLV per iperstatica $X=W_{EP}$

\rightarrow	$M(x)$	$M_0(x)$	M_x	M_θ	M_x	$\int M_x(M_0/EJ+\theta)dx$	$\int M_x M_x/EJdx$
AB b	0	$-1/2qx^2$	0	0	0	0	0
BA b	0	$1/2Fb-Fx+1/2qx^2$	0	0	0	0	0
BC $\sqrt{5}b$	0	$1/2Fb-\sqrt{5}/10Fx$	0	0	0	0	0
AC 2b	0	$-Fx+1/2qx^2$	0	0	0	0	0
CA 2b	0	$Fx-1/2qx^2$	0	0	0	0	0
DB 2b	0	0	0	0	0	0	0
BD 2b	0	0	0	0	0	0	0
DE b	$-x/b$	0	0	0	x^2/b^2	0	0
ED b	$1-x/b$	0	0	0	$1-2x/b+x^2/b^2$	0	0
CD b	0	0	0	0	0	0	0
DC b	0	0	0	0	0	0	0
EF b	-1	$5/2Fx$	$-Fb/EJ$	$-5/2Fx$	Fb/EJ	1	$(-5/4+1)Fb^2/EJ$
FE b	1	$-5/2Fb+5/2Fx$	Fb/EJ	$-5/2Fb+5/2Fx$	Fb/EJ	1	$(-5/4+1)Fb^2/EJ$
FC b	$-1+x/b$	$5/2Fb-5/2Fx$	0	$-5/2Fb+5Fx-5/2Fx^2/b$	0	$1-2x/b+x^2/b^2$	$(-5/6+0)Fb^2/EJ$
CF b	x/b	$-5/2Fx$	0	$-5/2Fx^2/b$	0	x^2/b^2	$1/3Xb/EJ$
totali							$5/3Xb/EJ$
iperstatica $X=W_{EP}$							$13/20Fb$

Sviluppi di calcolo iperstatica

$$L_{DE}^{xx} = \int_0^b (x^2/b^2) 1/EJ dx = [1/3 x^3/b^2]_0^b 1/EJ$$

$$= (1/3 b) 1/EJ = 1/3 b/EJ$$

$$L_{ED}^{xx} = \int_0^b (1 - 2x/b + x^2/b^2) 1/EJ dx = [x - x^2/b + 1/3 x^3/b^2]_0^b 1/EJ$$

$$= (b - b + 1/3 b) 1/EJ = 1/3 b/EJ$$

$$L_{EF}^{xx} = \int_0^b (1) 1/EJ dx = [x]_0^b 1/EJ$$

$$= (b) 1/EJ = b/EJ$$

$$L_{FE}^{xx} = \int_0^b (1) 1/EJ dx = [x]_0^b 1/EJ$$

$$= (b) 1/EJ = b/EJ$$

$$L_{FC}^{xx} = \int_0^b (1 - 2x/b + x^2/b^2) 1/EJ dx = [x - x^2/b + 1/3 x^3/b^2]_0^b 1/EJ$$

$$= (b - b + 1/3 b) 1/EJ = 1/3 b/EJ$$

$$L_{CF}^{xx} = \int_0^b (x^2/b^2) 1/EJ dx = [1/3 x^3/b^2]_0^b 1/EJ$$

$$= (1/3 b) 1/EJ = 1/3 b/EJ$$

$$L_{EF}^{xo} = \int_0^b (-5/2 x/b) Fb 1/EJ dx + \int_0^b (1) \theta dx = [-5/4 x^2/b]_0^b Fb 1/EJ + [x]_0^b \theta$$

$$= (-5/4 b) Fb 1/EJ + (b) \theta = -1/4 Fb^2/EJ$$

$$L_{FE}^{xo} = \int_0^b (-5/2 + 5/2 x/b) Fb 1/EJ dx + \int_0^b (-1) \theta dx = [-5/2 x + 5/4 x^2/b]_0^b Fb 1/EJ + [-x]_0^b \theta$$

$$= (-5/2 b + 5/4 b) Fb 1/EJ + (-b) \theta = -1/4 Fb^2/EJ$$

$$L_{FC}^{xo} = \int_0^b (-5/2 + 5x/b - 5/2 x^2/b^2) Fb 1/EJ dx = [-5/2 x + 5/2 x^2/b - 5/6 x^3/b^2]_0^b Fb 1/EJ$$

$$= (-5/2 b + 5/2 b - 5/6 b) Fb 1/EJ = -5/6 Fb^2/EJ$$

$$L_{CF}^{xo} = \int_0^b (-5/2 x^2/b^2) Fb 1/EJ dx = [-5/6 x^3/b^2]_0^b Fb 1/EJ$$

$$= (-5/6 b) Fb 1/EJ = -5/6 Fb^2/EJ$$

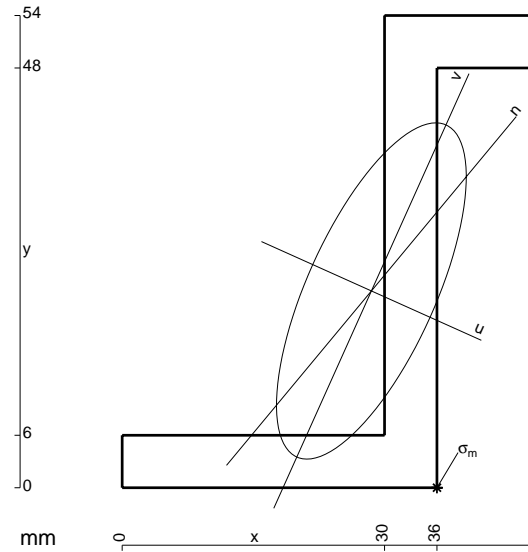

- A = 576. mm²
- J_x = 212976. mm⁴
- J_y = 67824. mm⁴
- J_{xy} = 81648. mm⁴
- J_u = 249641. mm⁴
- J_v = 31159. mm⁴
- α = artg(2J_{xy}/(J_y-J_x))/2 = -.4221
- c = cos α = .9122
- s = sin α = -.4097
- x_g = 28.5 mm
- y_g = 22.5 mm
- N = -1258. N
- T_y = 1700. N
- M_x = 805120. Nmm
- x_m = 36. mm
- u_m = 16.06 mm
- v_m = -17.45 mm
- σ_m = N/A - Mcv/J_u - Msu/J_v = 219.2 N/mm²

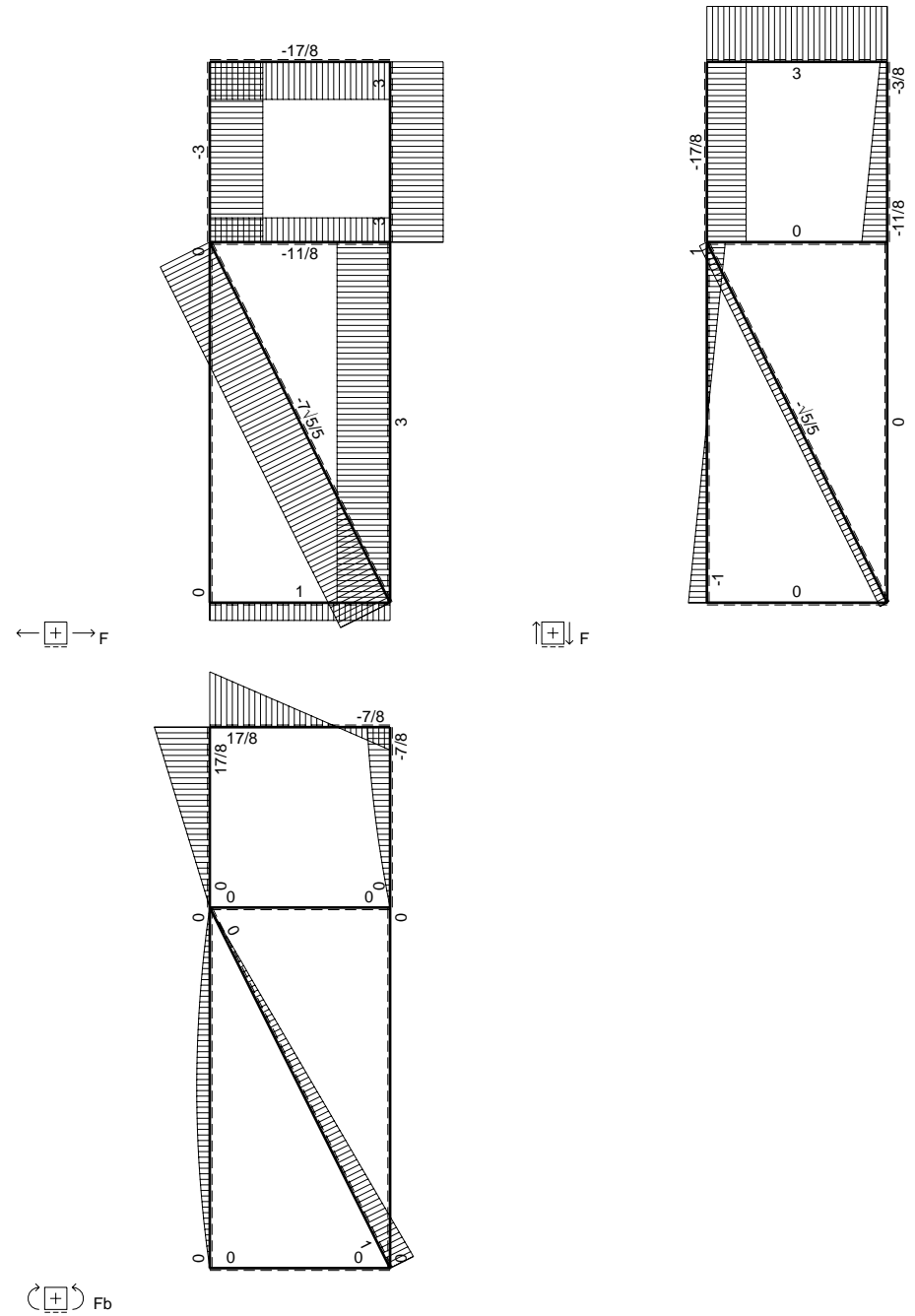
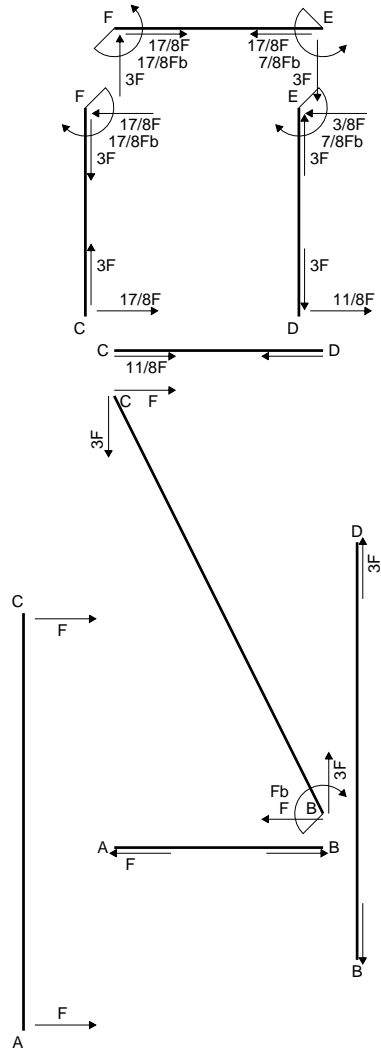

$$L_{DE}^{xx} = \int_0^b (x^2/b^2) 1/EJ dx = [1/3 x^3/b^2]_0^b 1/EJ$$

$$= (1/3 b) 1/EJ = 1/3 b/EJ$$

$$L_{ED}^{xx} = \int_0^b (1 - 2x/b + x^2/b^2) 1/EJ dx = [x - x^2/b + 1/3 x^3/b^2]_0^b 1/EJ$$

$$= (b - b + 1/3 b) 1/EJ = 1/3 b/EJ$$

$$L_{EF}^{xx} = \int_0^b (1) 1/EJ dx = [x]_0^b 1/EJ$$

$$= (b) 1/EJ = b/EJ$$

$$L_{FE}^{xx} = \int_0^b (1) 1/EJ dx = [x]_0^b 1/EJ$$

$$= (b) 1/EJ = b/EJ$$

$$L_{FC}^{xx} = \int_0^b (1 - 2x/b + x^2/b^2) 1/EJ dx = [x - x^2/b + 1/3 x^3/b^2]_0^b 1/EJ$$

$$= (b - b + 1/3 b) 1/EJ = 1/3 b/EJ$$

$$L_{CF}^{xx} = \int_0^b (x^2/b^2) 1/EJ dx = [1/3 x^3/b^2]_0^b 1/EJ$$

$$= (1/3 b) 1/EJ = 1/3 b/EJ$$

$$L_{DE}^{xo} = \int_0^b (1/2 x^2/b^2 - 1/2 x^3/b^3) Fb 1/EJ dx = [1/6 x^3/b^2 - 1/8 x^4/b^3]_0^b Fb 1/EJ$$

$$= (1/6 b - 1/8 b) Fb 1/EJ = 1/24 Fb^2/EJ$$

$$L_{ED}^{xo} = \int_0^b (1/2 x/b - x^2/b^2 + 1/2 x^3/b^3) Fb 1/EJ dx = [1/4 x^2/b - 1/3 x^3/b^2 + 1/8 x^4/b^3]_0^b Fb 1/EJ$$

$$= (1/4 b - 1/3 b + 1/8 b) Fb 1/EJ = 1/24 Fb^2/EJ$$

$$L_{EF}^{xo} = \int_0^b (-3x/b) Fb 1/EJ dx + \int_0^b (1) \theta dx = [-3/2 x^2/b]_0^b Fb 1/EJ + [x]_0^b \theta$$

$$= (-3/2 b) Fb 1/EJ + (b) \theta = -1/2 Fb^2/EJ$$

$$L_{FE}^{xo} = \int_0^b (-3 + 3x/b) Fb 1/EJ dx + \int_0^b (-1) \theta dx = [-3x + 3/2 x^2/b]_0^b Fb 1/EJ + [-x]_0^b \theta$$

$$= (-3b + 3/2 b) Fb 1/EJ + (-b) \theta = -1/2 Fb^2/EJ$$

$$L_{FC}^{xo} = \int_0^b (-3 + 6x/b - 3x^2/b^2) Fb 1/EJ dx = [-3x + 3x^2/b - x^3/b^2]_0^b Fb 1/EJ$$

$$= (-3b + 3b - b) Fb 1/EJ = - Fb^2/EJ$$

$$L_{CF}^{xo} = \int_0^b (-3x^2/b^2) Fb 1/EJ dx = [-x^3/b^2]_0^b Fb 1/EJ$$

$$= (-b) Fb 1/EJ = - Fb^2/EJ$$

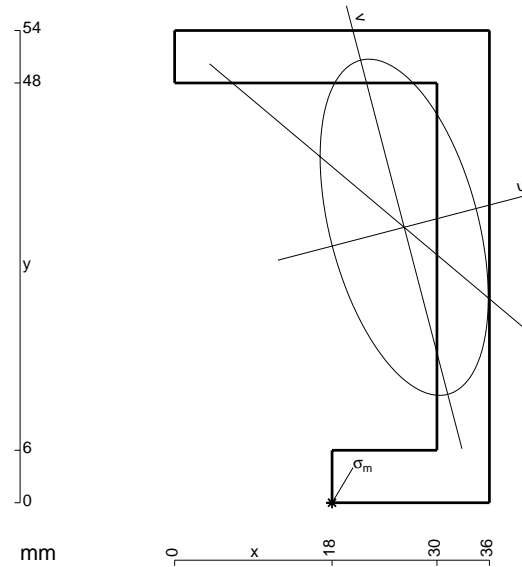

- A = 576. mm²
- J_x = 212976. mm⁴
- J_y = 53244. mm⁴
- J_{xy} = -44712. mm⁴
- J_u = 224640. mm⁴
- J_v = 41580. mm⁴
- α = arctg(2J_{xy}/(J_y-J_x))/2 = .2552
- c = cos α = .9676
- s = sin α = .2524
- x_g = 26.25 mm
- y_g = 31.5 mm
- N = -1551. N
- T_y = 2190. N
- M_x = 1054850. Nmm
- x_m = 18. mm
- u_m = -15.93 mm
- v_m = -28.4 mm
- σ_m = N/A - Mc_v/J_u - Ms_u/J_v = 228.4 N/mm²

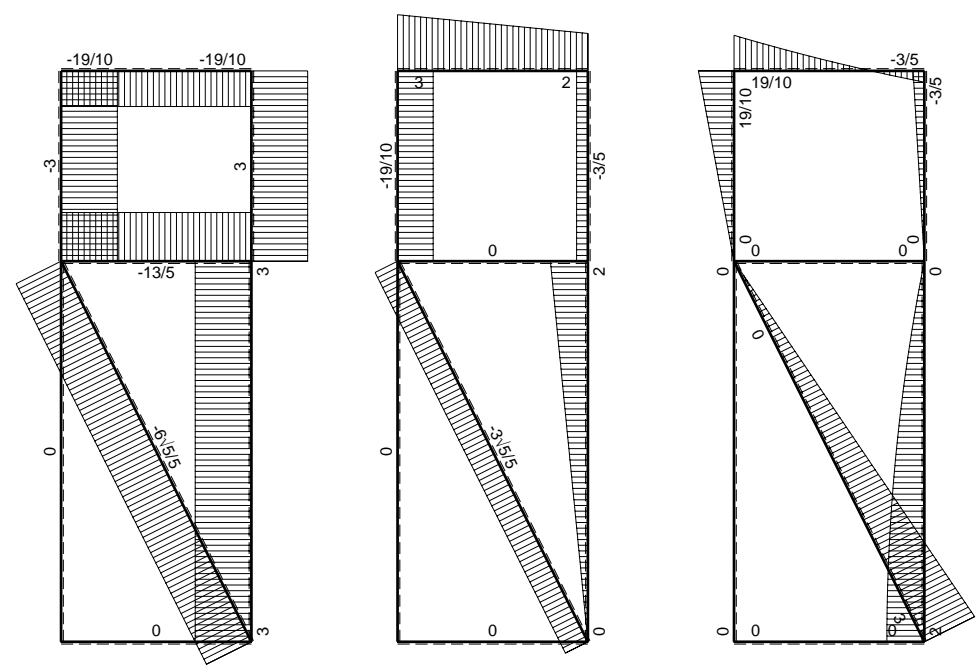
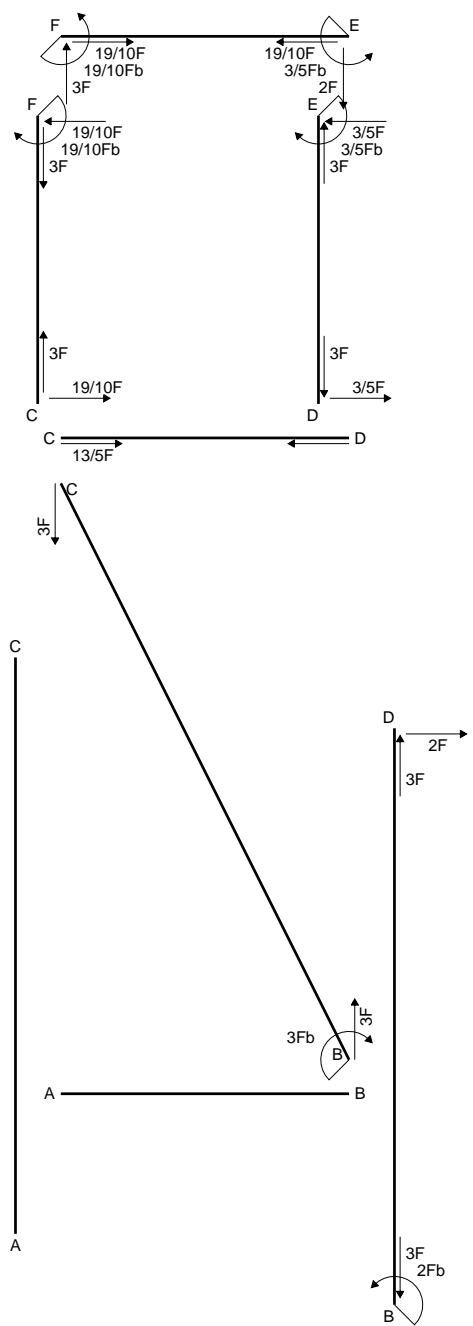

← ⊕ → F

↑ ⊕ ↓ F

⊕ ⊖ F_b

$$L_{DE}^{xx} = \int_0^b (x^2/b^2) 1/EJ dx = [1/3 x^3/b^2]_0^b 1/EJ$$

$$= (1/3 b) 1/EJ = 1/3 b/EJ$$

$$L_{ED}^{xx} = \int_0^b (1 - 2x/b + x^2/b^2) 1/EJ dx = [x - x^2/b + 1/3 x^3/b^2]_0^b 1/EJ$$

$$= (b - b + 1/3 b) 1/EJ = 1/3 b/EJ$$

$$L_{EF}^{xx} = \int_0^b (1) 1/EJ dx = [x]_0^b 1/EJ$$

$$= (b) 1/EJ = b/EJ$$

$$L_{FE}^{xx} = \int_0^b (1) 1/EJ dx = [x]_0^b 1/EJ$$

$$= (b) 1/EJ = b/EJ$$

$$L_{FC}^{xx} = \int_0^b (1 - 2x/b + x^2/b^2) 1/EJ dx = [x - x^2/b + 1/3 x^3/b^2]_0^b 1/EJ$$

$$= (b - b + 1/3 b) 1/EJ = 1/3 b/EJ$$

$$L_{CF}^{xx} = \int_0^b (x^2/b^2) 1/EJ dx = [1/3 x^3/b^2]_0^b 1/EJ$$

$$= (1/3 b) 1/EJ = 1/3 b/EJ$$

$$L_{EF}^{xo} = \int_0^b (-2x/b - 1/2 x^2/b^2) Fb 1/EJ dx + \int_0^b (1) \theta dx = [-x^2/b - 1/6 x^3/b^2]_0^b Fb 1/EJ + [x]_0^b \theta$$

$$= (-b - 1/6 b) Fb 1/EJ + (b) \theta = -1/6 Fb^2/EJ$$

$$L_{FE}^{xo} = \int_0^b (-5/2 + 3x/b - 1/2 x^2/b^2) Fb 1/EJ dx + \int_0^b (-1) \theta dx$$

$$= [-5/2 x + 3/2 x^2/b - 1/6 x^3/b^2]_0^b Fb 1/EJ + [-x]_0^b \theta$$

$$= (-5/2 b + 3/2 b - 1/6 b) Fb 1/EJ + (-b) \theta = -1/6 Fb^2/EJ$$

$$L_{FC}^{xo} = \int_0^b (-5/2 + 5x/b - 5/2 x^2/b^2) Fb 1/EJ dx = [-5/2 x + 5/2 x^2/b - 5/6 x^3/b^2]_0^b Fb 1/EJ$$

$$= (-5/2 b + 5/2 b - 5/6 b) Fb 1/EJ = -5/6 Fb^2/EJ$$

$$L_{CF}^{xo} = \int_0^b (-5/2 x^2/b^2) Fb 1/EJ dx = [-5/6 x^3/b^2]_0^b Fb 1/EJ$$

$$= (-5/6 b) Fb 1/EJ = -5/6 Fb^2/EJ$$

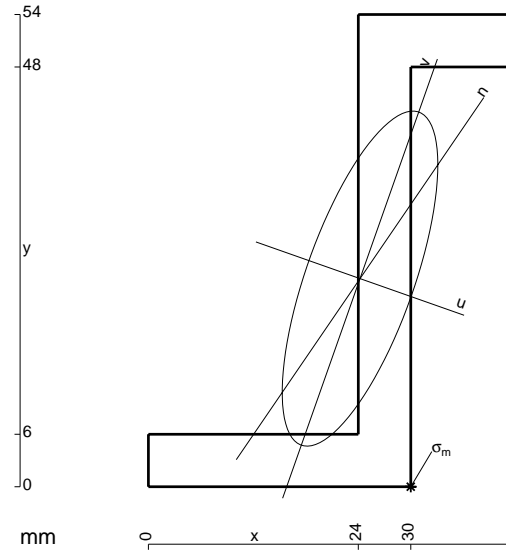

$$A = 540. \text{ mm}^2$$

$$J_x = 198266. \text{ mm}^4$$

$$J_y = 42746. \text{ mm}^4$$

$$J_{xy} = 62554. \text{ mm}^4$$

$$J_u = 220304. \text{ mm}^4$$

$$J_v = 20709. \text{ mm}^4$$

$$\alpha = \text{artg}(2J_{xy}/(J_y - J_x))/2 = -.3387$$

$$c = \cos \alpha = .9432$$

$$s = \sin \alpha = -.3323$$

$$x_g = 24.2 \text{ mm}$$

$$y_g = 23.8 \text{ mm}$$

$$N = -992.8 \text{ N}$$

$$T_y = -496.4 \text{ N}$$

$$M_x = 799200. \text{ Nmm}$$

$$x_m = 30. \text{ mm}$$

$$u_m = 13.38 \text{ mm}$$

$$v_m = -20.52 \text{ mm}$$

$$\sigma_m = N/A - Mcv/J_u - Msu/J_v = 239.9 \text{ N/mm}^2$$

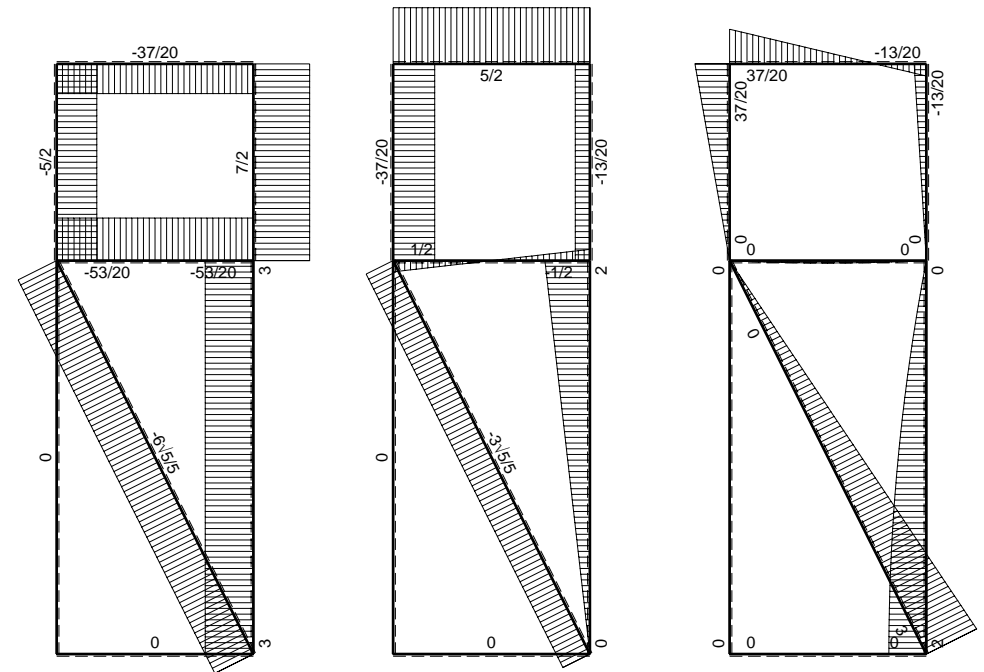
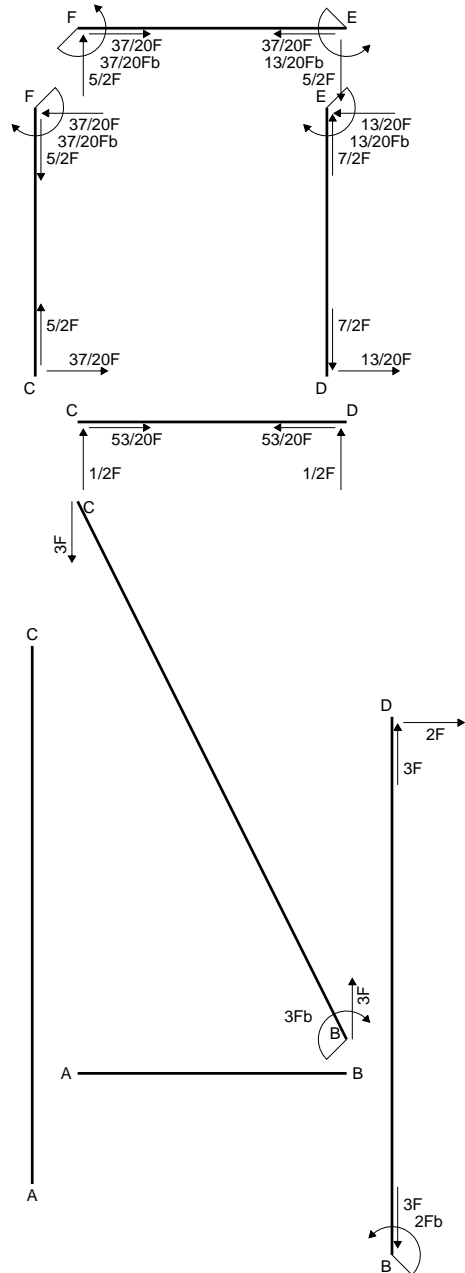

← ⊕ → F

↑ ⊕ ↓ F

⊕ ⊖ F_b

$$L_{DE}^{xx} = \int_0^b (x^2/b^2) 1/EJ dx = [1/3 x^3/b^2]_0^b 1/EJ$$

$$= (1/3 b) 1/EJ = 1/3 b/EJ$$

$$L_{ED}^{xx} = \int_0^b (1 - 2x/b + x^2/b^2) 1/EJ dx = [x - x^2/b + 1/3 x^3/b^2]_0^b 1/EJ$$

$$= (b - b + 1/3 b) 1/EJ = 1/3 b/EJ$$

$$L_{EF}^{xx} = \int_0^b (1) 1/EJ dx = [x]_0^b 1/EJ$$

$$= (b) 1/EJ = b/EJ$$

$$L_{FE}^{xx} = \int_0^b (1) 1/EJ dx = [x]_0^b 1/EJ$$

$$= (b) 1/EJ = b/EJ$$

$$L_{FC}^{xx} = \int_0^b (1 - 2x/b + x^2/b^2) 1/EJ dx = [x - x^2/b + 1/3 x^3/b^2]_0^b 1/EJ$$

$$= (b - b + 1/3 b) 1/EJ = 1/3 b/EJ$$

$$L_{CF}^{xx} = \int_0^b (x^2/b^2) 1/EJ dx = [1/3 x^3/b^2]_0^b 1/EJ$$

$$= (1/3 b) 1/EJ = 1/3 b/EJ$$

$$L_{EF}^{xo} = \int_0^b (-5/2 x/b) Fb 1/EJ dx + \int_0^b (1) \theta dx = [-5/4 x^2/b]_0^b Fb 1/EJ + [x]_0^b \theta$$

$$= (-5/4 b) Fb 1/EJ + (b) \theta = -1/4 Fb^2/EJ$$

$$L_{FE}^{xo} = \int_0^b (-5/2 + 5/2 x/b) Fb 1/EJ dx + \int_0^b (-1) \theta dx = [-5/2 x + 5/4 x^2/b]_0^b Fb 1/EJ + [-x]_0^b \theta$$

$$= (-5/2 b + 5/4 b) Fb 1/EJ + (-b) \theta = -1/4 Fb^2/EJ$$

$$L_{FC}^{xo} = \int_0^b (-5/2 + 5x/b - 5/2 x^2/b^2) Fb 1/EJ dx = [-5/2 x + 5/2 x^2/b - 5/6 x^3/b^2]_0^b Fb 1/EJ$$

$$= (-5/2 b + 5/2 b - 5/6 b) Fb 1/EJ = -5/6 Fb^2/EJ$$

$$L_{CF}^{xo} = \int_0^b (-5/2 x^2/b^2) Fb 1/EJ dx = [-5/6 x^3/b^2]_0^b Fb 1/EJ$$

$$= (-5/6 b) Fb 1/EJ = -5/6 Fb^2/EJ$$

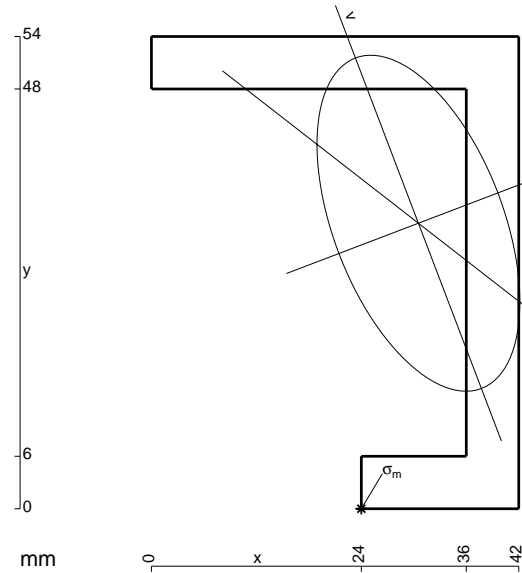

- A = 612. mm²
- J_x = 225968. mm⁴
- J_y = 82341. mm⁴
- J_{xy} = -64038. mm⁴
- J_u = 250373. mm⁴
- J_v = 57936. mm⁴
- α = artg(2J_{xy}/(J_y-J_x))/2 = .3641
- c = cosα = .9344
- s = sinα = .3561
- x_g = 30.53 mm
- y_g = 32.65 mm
- N = -2227. N
- T_y = -1114. N
- M_x = 946200. Nmm
- x_m = 24. mm
- u_m = -17.73 mm
- v_m = -28.18 mm
- σ_m = N/A - Mc_v/J_u - Ms_u/J_v = 199. N/mm²

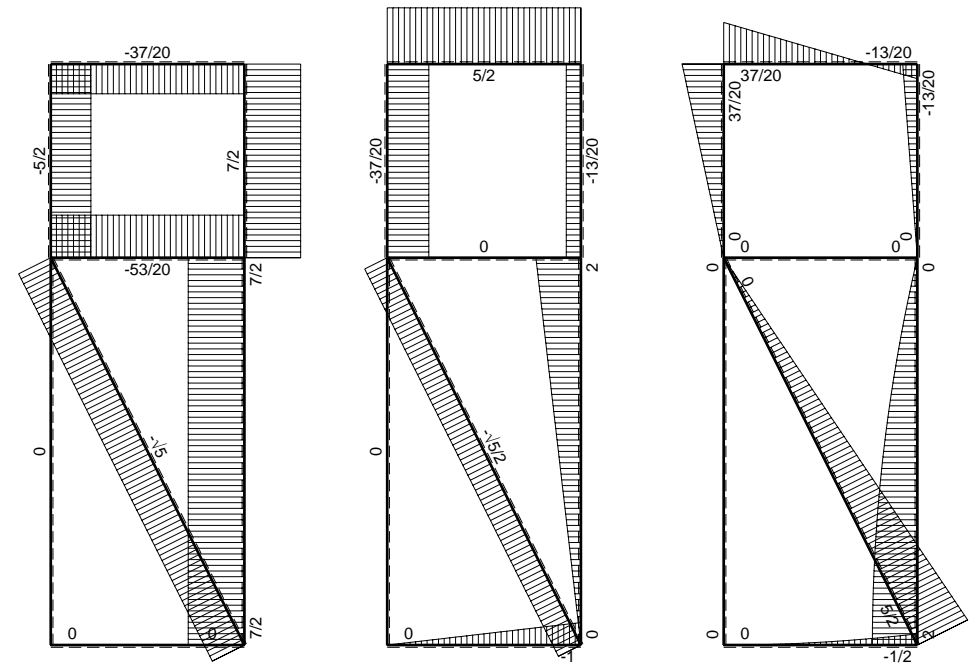
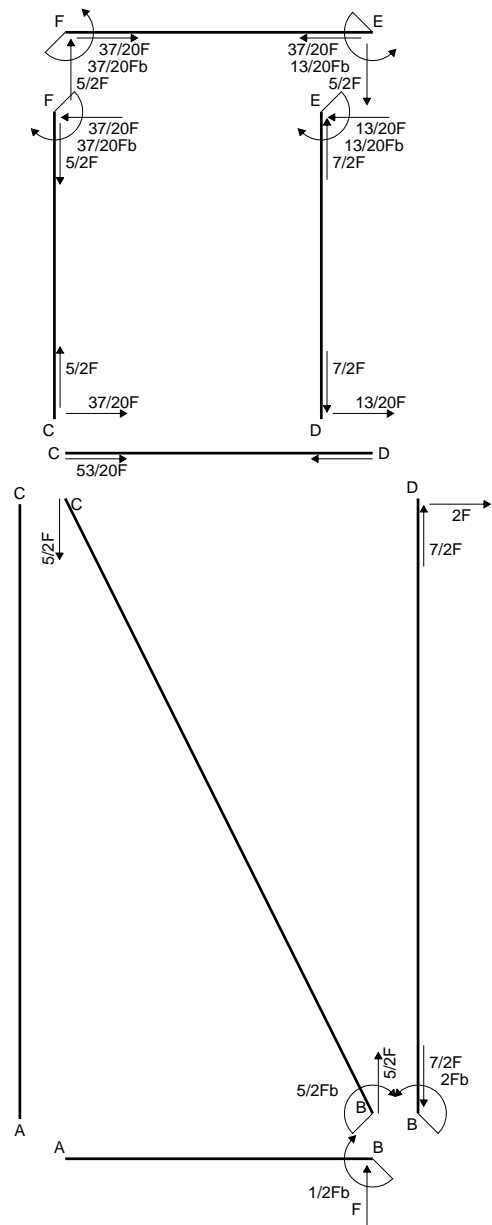

← ⊕ → F

↑ ⊕ ↓ F

⊕ ⊖ F_b

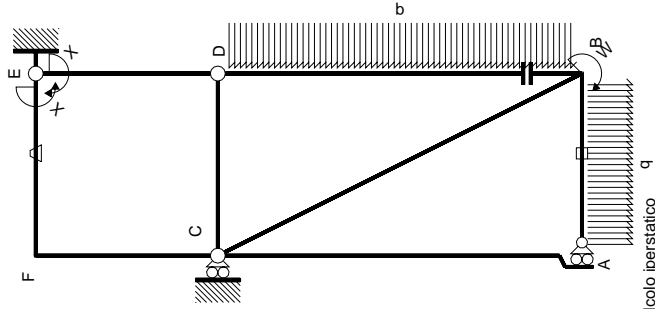

Schema di calcolo iperstatico

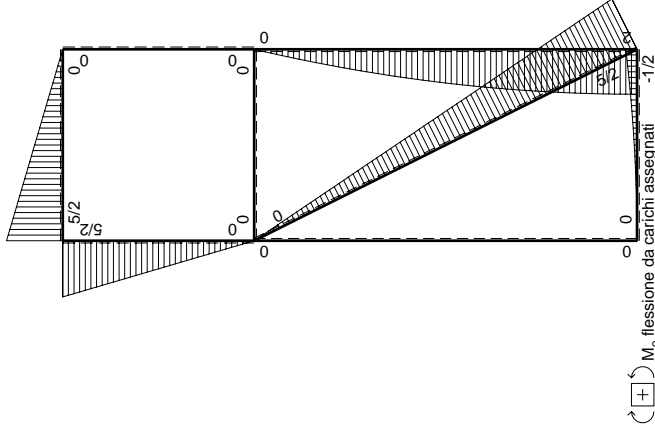

M_0 flessione da carichi assegnati

M_x flessione da iperstatica $X=1$

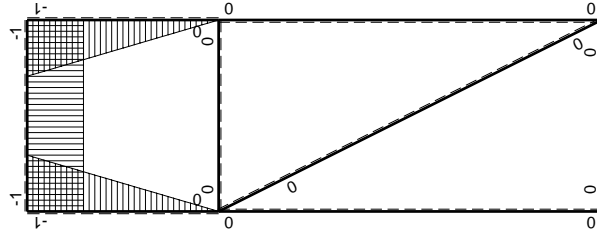

→	$M(x)$		$M_0(x)$		$M_x \theta$	$M_x M_x$	$\int M_x(M_0/EJ+\theta)dx$	$\int M_x M_x/EJ dx$	AB	BA	BC	CA	AC	CB	CD	DC	FE	EF	FC	CF	totali	iperstatica $X=W_{EP}$		
	$M(x)$	θ	$M_0(x)$	$M_x \theta$																				
AB	0	$-1/2qx^2$	0	0	0	0	0	0	0	0	0	0	0	0	0	0	0	0	0	0	0	0	0	
BA	0	$1/2Fb-Fx+1/2qx^2$	0	0	0	0	0	0	0	0	0	0	0	0	0	0	0	0	0	0	0	0	0	0
BC	0	$5/2Fb-\sqrt{5/2}Fx$	0	0	0	0	0	0	0	0	0	0	0	0	0	0	0	0	0	0	0	0	0	0
CA	0	0	0	0	0	0	0	0	0	0	0	0	0	0	0	0	0	0	0	0	0	0	0	0
AC	0	0	0	0	0	0	0	0	0	0	0	0	0	0	0	0	0	0	0	0	0	0	0	0
CB	0	0	0	0	0	0	0	0	0	0	0	0	0	0	0	0	0	0	0	0	0	0	0	0
DB	0	$2Fx-1/2qx^2$	0	0	0	0	0	0	0	0	0	0	0	0	0	0	0	0	0	0	0	0	0	0
BD	0	$-2Fb+1/2qx^2$	0	0	0	0	0	0	0	0	0	0	0	0	0	0	0	0	0	0	0	0	0	0
DE	0	$-x/b$	0	0	0	0	0	0	0	0	0	0	0	0	0	0	0	0	0	0	0	0	0	0
ED	0	$1-x/b$	0	0	0	0	0	0	0	0	0	0	0	0	0	0	0	0	0	0	0	0	0	0
CD	0	0	0	0	0	0	0	0	0	0	0	0	0	0	0	0	0	0	0	0	0	0	0	0
DC	0	0	0	0	0	0	0	0	0	0	0	0	0	0	0	0	0	0	0	0	0	0	0	0
FE	-1	$5/2Fx$	-Fb/EJ	$-5/2Fx$	Fb/EJ	1	$(-5/4+1)Fb^2/EJ$	Xb/EJ	0	0	0	0	0	0	0	0	0	0	0	0	0	0	0	0
EF	1	$-5/2Fb+5/2Fx$	Fb/EJ	$-5/2Fb+5/2Fx$	Fb/EJ	1	$(-5/4+1)Fb^2/EJ$	Xb/EJ	0	0	0	0	0	0	0	0	0	0	0	0	0	0	0	0
FC	-1+x/b	$5/2Fb-5/2Fx$	0	$-5/2Fb+5Fx-5/2Fx^2/b$	0	$1-2x/b+x^2/b^2$	$(-5/6+0)Fb^2/EJ$	$1/3Xb/EJ$	0	0	0	0	0	0	0	0	0	0	0	0	0	0	0	0
CF	x/b	$-5/2Fx$	0	$-5/2Fx^2/b$	0	x^2/b^2	$(-5/6+0)Fb^2/EJ$	$1/3Xb/EJ$	0	0	0	0	0	0	0	0	0	0	0	0	0	0	0	0
totali																								

Sviluppi di calcolo iperstatica

$$L_{DE}^{xx} = \int_0^b (x^2/b^2) 1/EJ dx = [1/3 x^3/b^2]_0^b 1/EJ$$

$$= (1/3 b) 1/EJ = 1/3 b/EJ$$

$$L_{ED}^{xx} = \int_0^b (1 - 2x/b + x^2/b^2) 1/EJ dx = [x - x^2/b + 1/3 x^3/b^2]_0^b 1/EJ$$

$$= (b - b + 1/3 b) 1/EJ = 1/3 b/EJ$$

$$L_{EF}^{xx} = \int_0^b (1) 1/EJ dx = [x]_0^b 1/EJ$$

$$= (b) 1/EJ = b/EJ$$

$$L_{FE}^{xx} = \int_0^b (1) 1/EJ dx = [x]_0^b 1/EJ$$

$$= (b) 1/EJ = b/EJ$$

$$L_{FC}^{xx} = \int_0^b (1 - 2x/b + x^2/b^2) 1/EJ dx = [x - x^2/b + 1/3 x^3/b^2]_0^b 1/EJ$$

$$= (b - b + 1/3 b) 1/EJ = 1/3 b/EJ$$

$$L_{CF}^{xx} = \int_0^b (x^2/b^2) 1/EJ dx = [1/3 x^3/b^2]_0^b 1/EJ$$

$$= (1/3 b) 1/EJ = 1/3 b/EJ$$

$$L_{EF}^{xo} = \int_0^b (-5/2 x/b) Fb 1/EJ dx + \int_0^b (1) \theta dx = [-5/4 x^2/b]_0^b Fb 1/EJ + [x]_0^b \theta$$

$$= (-5/4 b) Fb 1/EJ + (b) \theta = -1/4 Fb^2/EJ$$

$$L_{FE}^{xo} = \int_0^b (-5/2 + 5/2 x/b) Fb 1/EJ dx + \int_0^b (-1) \theta dx = [-5/2 x + 5/4 x^2/b]_0^b Fb 1/EJ + [-x]_0^b \theta$$

$$= (-5/2 b + 5/4 b) Fb 1/EJ + (-b) \theta = -1/4 Fb^2/EJ$$

$$L_{FC}^{xo} = \int_0^b (-5/2 + 5x/b - 5/2 x^2/b^2) Fb 1/EJ dx = [-5/2 x + 5/2 x^2/b - 5/6 x^3/b^2]_0^b Fb 1/EJ$$

$$= (-5/2 b + 5/2 b - 5/6 b) Fb 1/EJ = -5/6 Fb^2/EJ$$

$$L_{CF}^{xo} = \int_0^b (-5/2 x^2/b^2) Fb 1/EJ dx = [-5/6 x^3/b^2]_0^b Fb 1/EJ$$

$$= (-5/6 b) Fb 1/EJ = -5/6 Fb^2/EJ$$

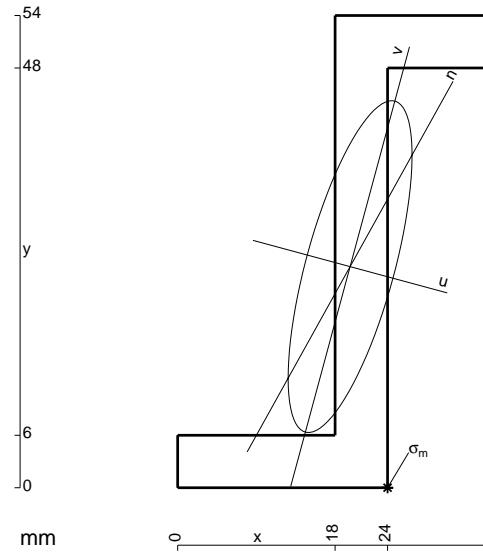

$A = 504. \text{ mm}^2$
 $J_x = 181471. \text{ mm}^4$
 $J_y = 25303. \text{ mm}^4$
 $J_{xy} = 45545. \text{ mm}^4$
 $J_u = 193783. \text{ mm}^4$
 $J_v = 12991. \text{ mm}^4$
 $\alpha = \text{artg}(2J_{xy}/(J_y - J_x))/2 = -.2640$
 $c = \cos \alpha = .9653$
 $s = \sin \alpha = -.2610$
 $x_g = 19.71 \text{ mm}$
 $y_g = 25.29 \text{ mm}$
 $N = -1386. \text{ N}$
 $T_y = -693.2 \text{ N}$
 $M_x = 635500. \text{ Nmm}$
 $x_m = 24. \text{ mm}$
 $u_m = 10.74 \text{ mm}$
 $v_m = -23.29 \text{ mm}$
 $\sigma_m = N/A - Mcv/J_u - Msu/J_v = 208. \text{ N/mm}^2$

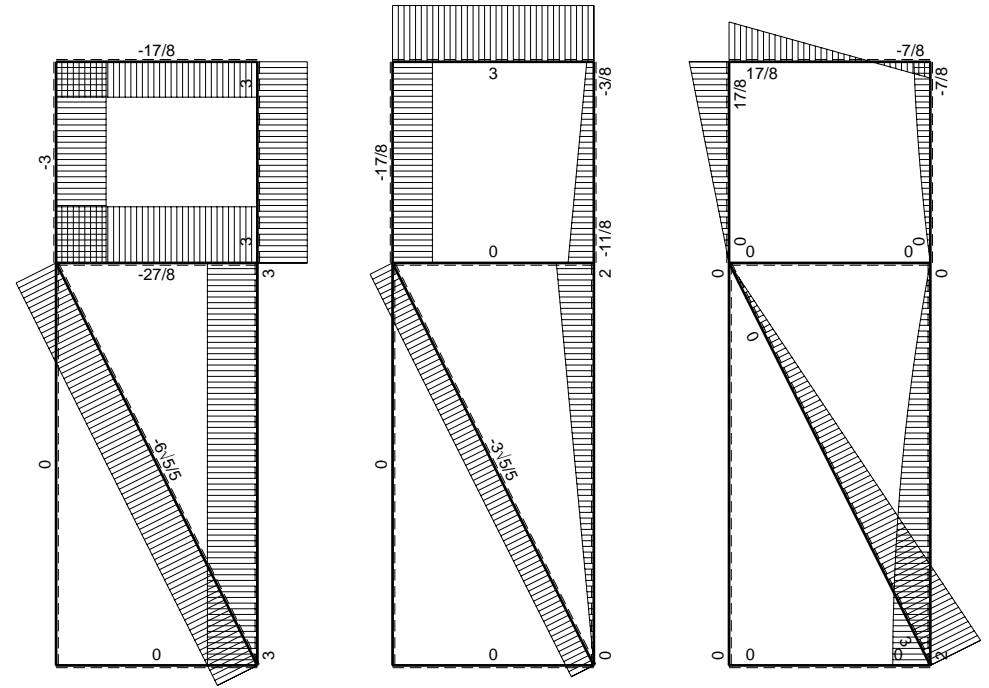
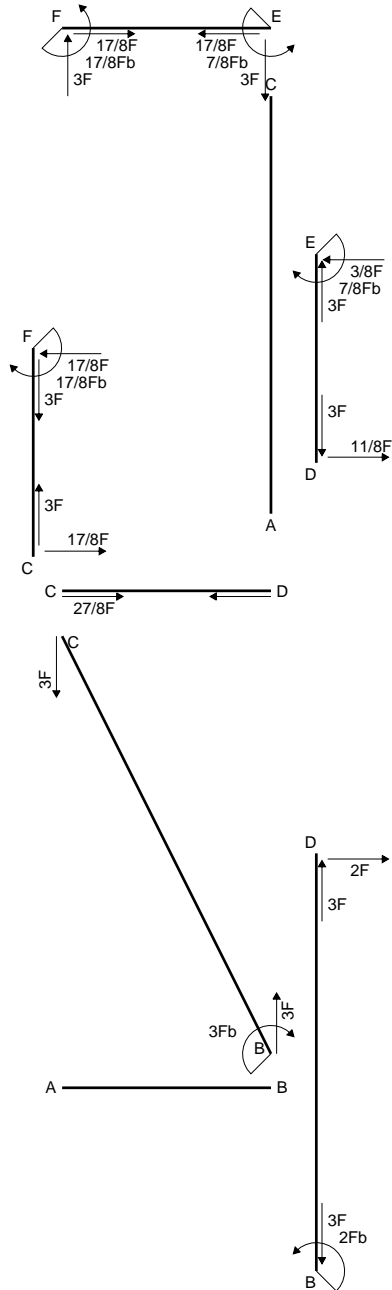

← ⊕ → F

↑ ⊕ ↓ F

⊕ F_b

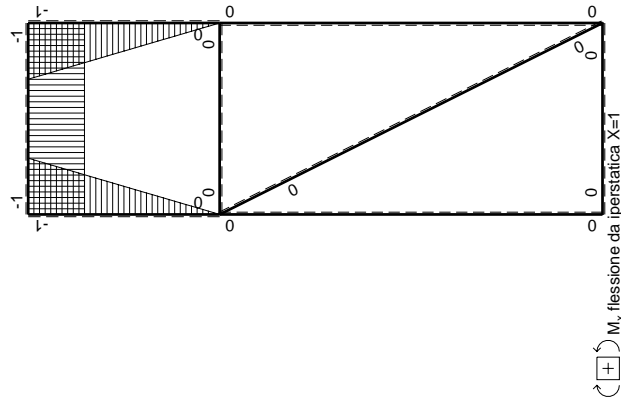
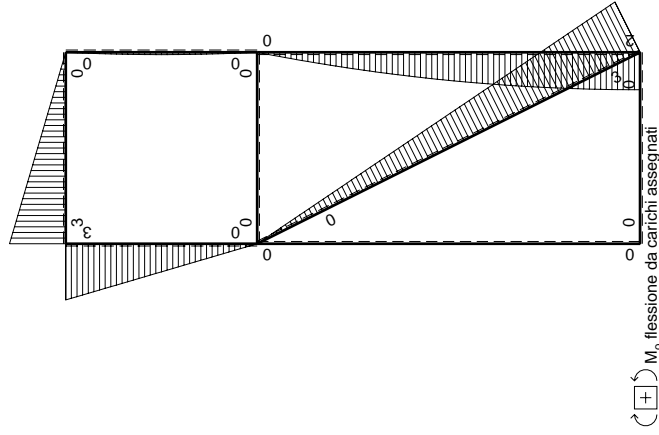
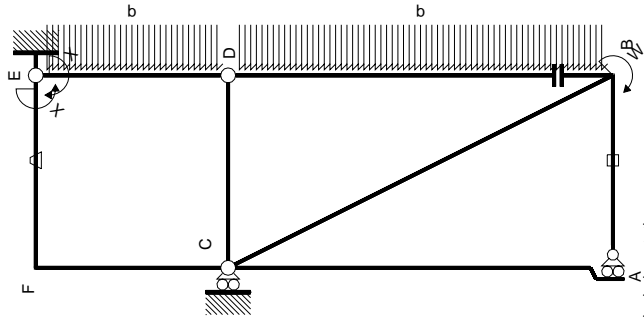

Quadro contributi PLV per iperstatica $X=W_{EF}$

\leftarrow	$M^x(x)$	$M^0(x)$	θ	$M^x M_0$	$M^x \theta$	$M^x M_x$	$\int M^x(M_0/EJ+\theta)dx$	$\int M^x M_x/EJdx$
AB b	0	0	0	0	0	0	0+0	0
BA b	0	0	0	0	0	0	0	0
BC $\sqrt{5}b$	0	$3Fb-3\sqrt{5}/5Fx$	0	0	0	0	0+0	0
AC 2b	0	0	0	0	0	0	0+0	0
CA 2b	0	0	0	0	0	0	0+0	0
DB 2b	0	$2Fx-1/2qx^2$	0	0	0	0	0+0	0
BD 2b	0	$-2Fb+1/2qx^2$	0	0	0	0	0+0	0
DE b	$-x/b$	$-1/2Fx+1/2qx^2$	0	$1/2Fx^2/b-1/2qx^3/b$	0	x^2/b^2	$(1/24+0)Fb^2/EJ$	$1/3Xb/EJ$
ED b	$1-x/b$	$1/2Fx-1/2qx^2$	0	$1/2Fx-Fx^2/b+1/2qx^3/b$	0	$1-2x/b+x^2/b^2$	$(1/24+0)Fb^2/EJ$	$1/3Xb/EJ$
CD b	0	0	0	0	0	0	0+0	0
DC b	0	0	0	0	0	0	0+0	0
EF b	-1	$3Fx$	$-Fb/EJ$	$-3Fx$	Fb/EJ	1	$(-3/2+1)Fb^2/EJ$	Xb/EJ
FE b	1	$-3Fb+3Fx$	Fb/EJ	$-3Fb+3Fx$	Fb/EJ	1	$(-3/2+1)Fb^2/EJ$	Xb/EJ
FC b	$-1+x/b$	$3Fb-3Fx$	0	$-3Fb+6Fx-3Fx^2/b$	0	$1-2x/b+x^2/b^2$	$(-1+0)Fb^2/EJ$	$1/3Xb/EJ$
CF b	x/b	$-3Fx$	0	$-3Fx^2/b$	0	x^2/b^2	$-35/24Fb^2/EJ$	$5/3Xb/EJ$
totali								
							$7/8Fb$	

Sviluppi di calcolo iperstatica

$$L_{DE}^{xx} = \int_0^b (x^2/b^2) 1/EJ dx = [1/3 x^3/b^2]_0^b 1/EJ$$

$$= (1/3 b) 1/EJ = 1/3 b/EJ$$

$$L_{ED}^{xx} = \int_0^b (1 - 2x/b + x^2/b^2) 1/EJ dx = [x - x^2/b + 1/3 x^3/b^2]_0^b 1/EJ$$

$$= (b - b + 1/3 b) 1/EJ = 1/3 b/EJ$$

$$L_{EF}^{xx} = \int_0^b (1) 1/EJ dx = [x]_0^b 1/EJ$$

$$= (b) 1/EJ = b/EJ$$

$$L_{FE}^{xx} = \int_0^b (1) 1/EJ dx = [x]_0^b 1/EJ$$

$$= (b) 1/EJ = b/EJ$$

$$L_{FC}^{xx} = \int_0^b (1 - 2x/b + x^2/b^2) 1/EJ dx = [x - x^2/b + 1/3 x^3/b^2]_0^b 1/EJ$$

$$= (b - b + 1/3 b) 1/EJ = 1/3 b/EJ$$

$$L_{CF}^{xx} = \int_0^b (x^2/b^2) 1/EJ dx = [1/3 x^3/b^2]_0^b 1/EJ$$

$$= (1/3 b) 1/EJ = 1/3 b/EJ$$

$$L_{DE}^{xo} = \int_0^b (1/2 x^2/b^2 - 1/2 x^3/b^3) Fb 1/EJ dx = [1/6 x^3/b^2 - 1/8 x^4/b^3]_0^b Fb 1/EJ$$

$$= (1/6 b - 1/8 b) Fb 1/EJ = 1/24 Fb^2/EJ$$

$$L_{ED}^{xo} = \int_0^b (1/2 x/b - x^2/b^2 + 1/2 x^3/b^3) Fb 1/EJ dx = [1/4 x^2/b - 1/3 x^3/b^2 + 1/8 x^4/b^3]_0^b Fb 1/EJ$$

$$= (1/4 b - 1/3 b + 1/8 b) Fb 1/EJ = 1/24 Fb^2/EJ$$

$$L_{EF}^{xo} = \int_0^b (-3x/b) Fb 1/EJ dx + \int_0^b (1) \theta dx = [-3/2 x^2/b]_0^b Fb 1/EJ + [x]_0^b \theta$$

$$= (-3/2 b) Fb 1/EJ + (b) \theta = -1/2 Fb^2/EJ$$

$$L_{FE}^{xo} = \int_0^b (-3 + 3x/b) Fb 1/EJ dx + \int_0^b (-1) \theta dx = [-3x + 3/2 x^2/b]_0^b Fb 1/EJ + [-x]_0^b \theta$$

$$= (-3b + 3/2 b) Fb 1/EJ + (-b) \theta = -1/2 Fb^2/EJ$$

$$L_{FC}^{xo} = \int_0^b (-3 + 6x/b - 3x^2/b^2) Fb 1/EJ dx = [-3x + 3x^2/b - x^3/b^2]_0^b Fb 1/EJ$$

$$= (-3b + 3b - b) Fb 1/EJ = -Fb^2/EJ$$

$$L_{CF}^{xo} = \int_0^b (-3x^2/b^2) Fb 1/EJ dx = [-x^3/b^2]_0^b Fb 1/EJ$$

$$= (-b) Fb 1/EJ = -Fb^2/EJ$$

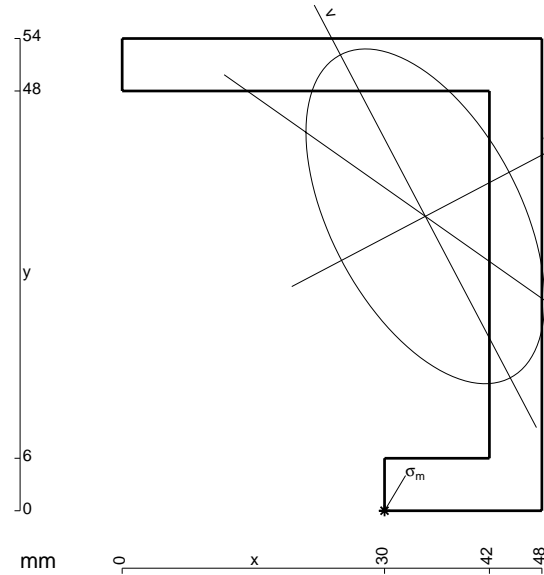

- A = 648. mm²
- J_x = 237528. mm⁴
- J_y = 120672. mm⁴
- J_{xy} = -84960. mm⁴
- J_u = 282212. mm⁴
- J_v = 75988. mm⁴
- α = arctg(2J_{xy}/(J_y-J_x))/2 = .4842
- c = cos α = .8851
- s = sin α = .4655
- x_g = 34.67 mm
- y_g = 33.67 mm
- N = -2120. N
- T_y = -1060. N
- M_x = 1066500. Nmm
- x_m = 30. mm
- u_m = -19.8 mm
- v_m = -27.62 mm
- σ_m = N/A - Mc_v/J_u - Ms_u/J_v = 218.5 N/mm²

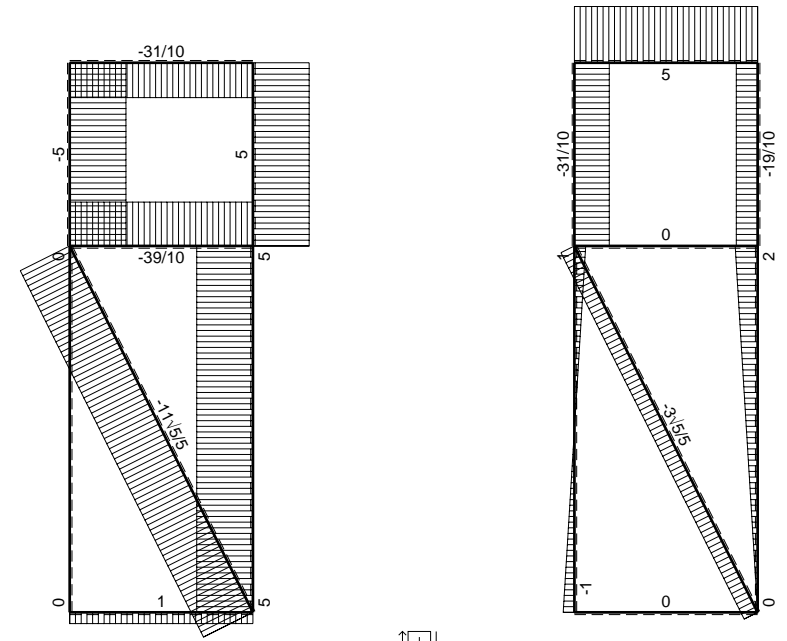
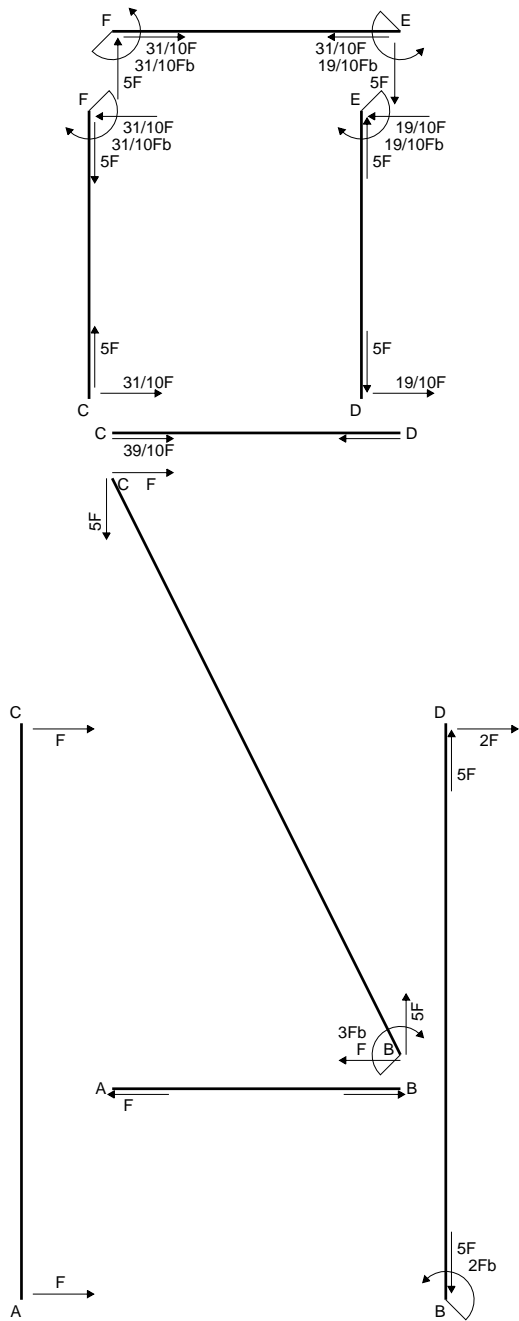

← ⊕ → F

↑ ⊕ ↓ F

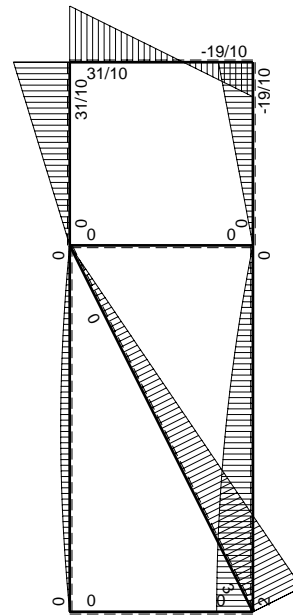

⊕ ⊖ F_b

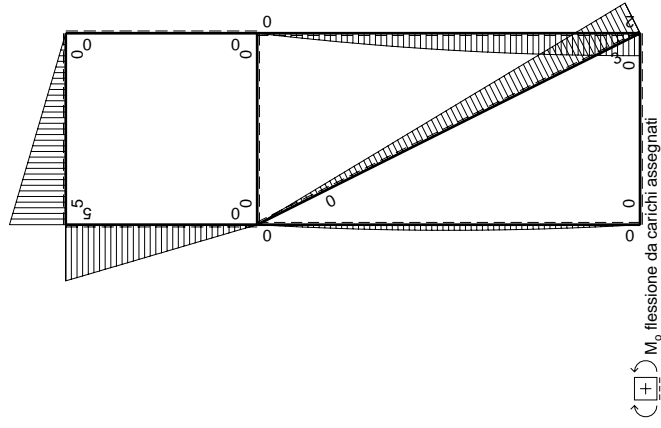
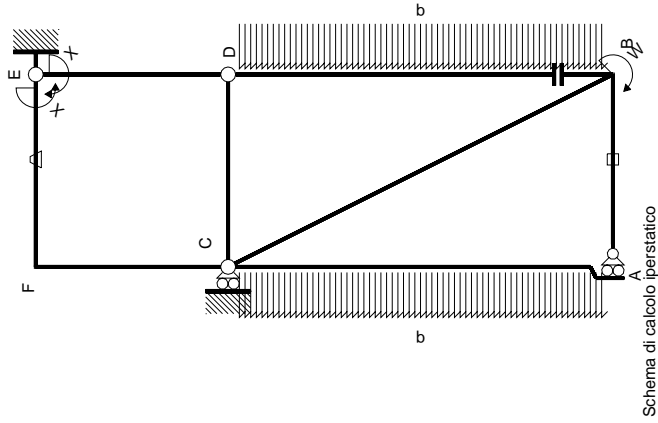

Quadro contributi PLV per iperstatica $X=W_{Ef}$

\rightarrow	$M^x(x)$	$M^0(x)$	θ	$M^x M_0$	$M^x \theta$	$M^x M_x$	$\int M^x (M_0/EJ + \theta) dx$	$\int M^x M_x / E J dx$	
AB b	0	0	0	0	0	0	0	0	
BA b	0	0	0	0	0	0	0	0	
BC $\sqrt{5}b$	0	$3Fb-3\sqrt{5}/5Fx$	0	0	0	0	0	0	
AC 2b	0	$-Fx+1/2qx^2$	0	0	0	0	0	0	
CA 2b	0	$Fx-1/2qx^2$	0	0	0	0	0	0	
DB 2b	0	$2Fx-1/2qx^2$	0	0	0	0	0	0	
BD 2b	0	$-2Fb+1/2qx^2$	0	0	0	0	0	0	
DE b	$-x/b$	0	0	0	0	0	x^2/b^2	0	
ED b	$1-x/b$	0	0	0	0	0	$1-2x/b+x^2/b^2$	$1/3Xb/EJ$	
CD b	0	0	0	0	0	0	0	0	
DC b	0	0	0	0	0	0	0	0	
EF b	-1	$5Fx$	$-Fb/EJ$	$-5Fx$	Fb/EJ	Fb/EJ	1	$(-5/2+1)Fb^2/EJ$	Xb/EJ
FE b	1	$-5Fb+5Fx$	Fb/EJ	$-5Fb+5Fx$	Fb/EJ	Fb/EJ	1	$(-5/3+0)Fb^2/EJ$	$1/3Xb/EJ$
FC b	$-1+x/b$	$5Fb-5Fx$	0	$-5Fb+10Fx-5Fx^2/b$	0	0	$1-2x/b+x^2/b^2$	$-19/6Fb^2/EJ$	$5/3Xb/EJ$
CF b	x/b	$-5Fx$	0	$-5Fx^2/b$	0	0	x^2/b^2	$19/10Fb$	
totali									

Sviluppi di calcolo iperstatica



$$L_{DE}^{xx} = \int_0^b (x^2/b^2) 1/EJ dx = [1/3 x^3/b^2]_0^b 1/EJ$$

$$= (1/3 b) 1/EJ = 1/3 b/EJ$$

$$L_{ED}^{xx} = \int_0^b (1 - 2x/b + x^2/b^2) 1/EJ dx = [x - x^2/b + 1/3 x^3/b^2]_0^b 1/EJ$$

$$= (b - b + 1/3 b) 1/EJ = 1/3 b/EJ$$

$$L_{EF}^{xx} = \int_0^b (1) 1/EJ dx = [x]_0^b 1/EJ$$

$$= (b) 1/EJ = b/EJ$$

$$L_{FE}^{xx} = \int_0^b (1) 1/EJ dx = [x]_0^b 1/EJ$$

$$= (b) 1/EJ = b/EJ$$

$$L_{FC}^{xx} = \int_0^b (1 - 2x/b + x^2/b^2) 1/EJ dx = [x - x^2/b + 1/3 x^3/b^2]_0^b 1/EJ$$

$$= (b - b + 1/3 b) 1/EJ = 1/3 b/EJ$$

$$L_{CF}^{xx} = \int_0^b (x^2/b^2) 1/EJ dx = [1/3 x^3/b^2]_0^b 1/EJ$$

$$= (1/3 b) 1/EJ = 1/3 b/EJ$$

$$L_{EF}^{xo} = \int_0^b (-5x/b) Fb 1/EJ dx + \int_0^b (1) \theta dx = [-5/2 x^2/b]_0^b Fb 1/EJ + [x]_0^b \theta$$

$$= (-5/2 b) Fb 1/EJ + (b) \theta = -3/2 Fb^2/EJ$$

$$L_{FE}^{xo} = \int_0^b (-5 + 5x/b) Fb 1/EJ dx + \int_0^b (-1) \theta dx = [-5x + 5/2 x^2/b]_0^b Fb 1/EJ + [-x]_0^b \theta$$

$$= (-5b + 5/2 b) Fb 1/EJ + (-b) \theta = -3/2 Fb^2/EJ$$

$$L_{FC}^{xo} = \int_0^b (-5 + 10x/b - 5x^2/b^2) Fb 1/EJ dx = [-5x + 5x^2/b - 5/3 x^3/b^2]_0^b Fb 1/EJ$$

$$= (-5b + 5b - 5/3 b) Fb 1/EJ = -5/3 Fb^2/EJ$$

$$L_{CF}^{xo} = \int_0^b (-5x^2/b^2) Fb 1/EJ dx = [-5/3 x^3/b^2]_0^b Fb 1/EJ$$

$$= (-5/3 b) Fb 1/EJ = -5/3 Fb^2/EJ$$

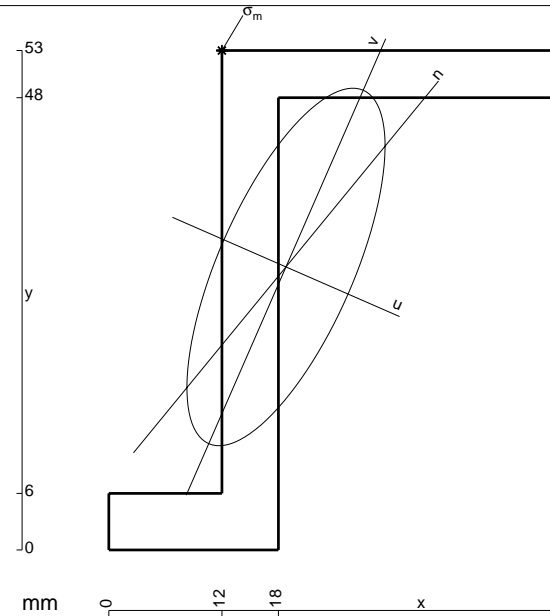

$$A = 540. \text{ mm}^2$$

$$J_x = 194387. \text{ mm}^4$$

$$J_y = 59702. \text{ mm}^4$$

$$J_{xy} = 72778. \text{ mm}^4$$

$$J_u = 226199. \text{ mm}^4$$

$$J_v = 27891. \text{ mm}^4$$

$$\alpha = \text{artg}(2J_{xy}/(J_y - J_x))/2 = -.4121$$

$$c = \cos \alpha = .9163$$

$$s = \sin \alpha = -.4005$$

$$x_g = 18.8 \text{ mm}$$

$$y_g = 30.03 \text{ mm}$$

$$N = -2550. \text{ N}$$

$$T_y = -1581. \text{ N}$$

$$M_x = 758880. \text{ Nmm}$$

$$x_m = 12. \text{ mm}$$

$$y_m = 53. \text{ mm}$$

$$u_m = -15.43 \text{ mm}$$

$$v_m = 18.32 \text{ mm}$$

$$\sigma_m = N/A - Mcv/J_u - Msu/J_v = -229.2 \text{ N/mm}^2$$

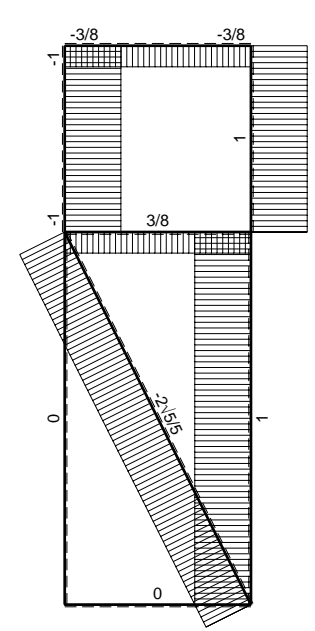
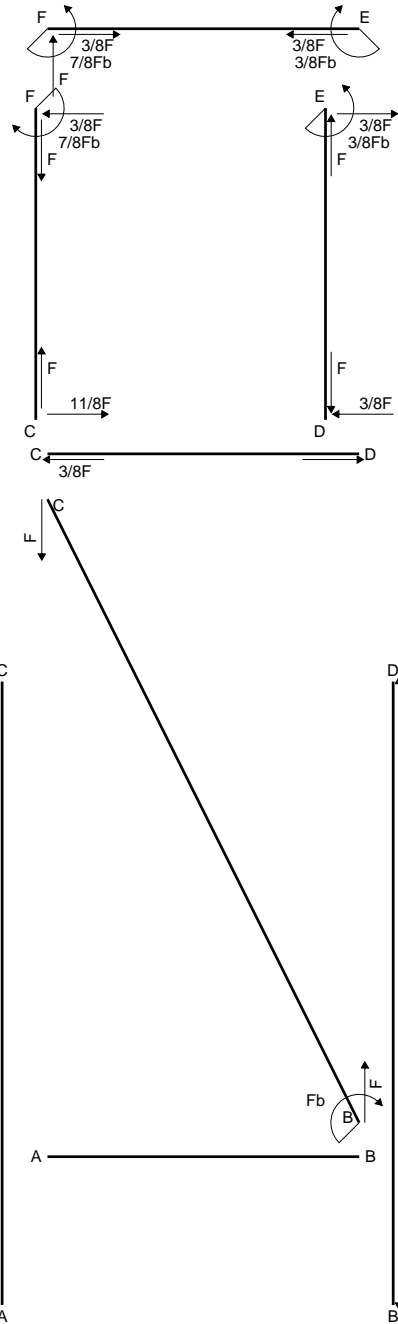

← ⊕ → F

↑ ⊕ ↓ F

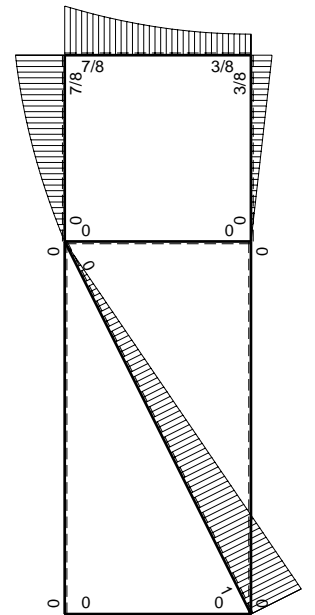

⊕ ⊖ F_b

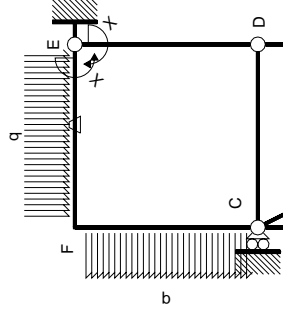

Schema di calcolo iperstatico

M₀ flessione da carichi assegnati

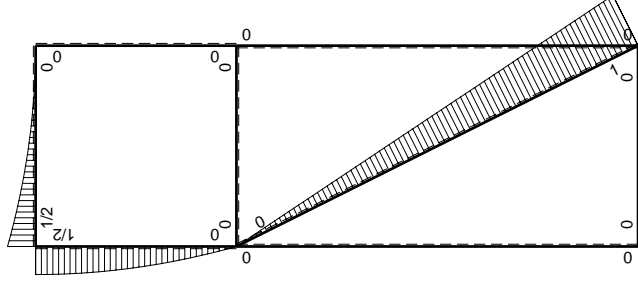

Quadro contributi PLV per iperstatica X=W ^{EP}		M ₀ (x)	θ	M ₀	M _θ	M _{M_X}	∫M _X (M ₀ /EJ+θ)dx	M _{M_X} /EJdx
		←	M ₀ (x)	θ	M ₀	M _θ	M _{M_X}	∫M _X (M ₀ /EJ+θ)dx
AB	B	0	0	0	0	0	0+0	0
BA	A	0	0	0	0	0	0	0
BC	C	0	Fb-√5/5Fx	0	0	0	0	0
CB	B	0	0	0	0	0	0	0
CA	A	0	0	0	0	0	0+0	0
AC	C	0	0	0	0	0	0	0
CA	A	0	0	0	0	0	0	0
DB	B	0	0	0	0	0	0+0	0
BD	D	0	0	0	0	0	0	0
DE	E	-x/b	0	0	0	x ² /b ²	0+0	1/3Xb/EJ
ED	D	1-x/b	0	0	0	1-2x/b+x ² /b ²	0+0	1/3Xb/EJ
CD	D	0	0	0	0	0	0	0
DC	C	0	0	0	0	0	0+0	0
EF	F	-1	1/2qx ²	-Fb/EJ	-1/2Fx ² /b	1	1	Xb/EJ
FE	E	1	-1/2Fb+Fx-1/2qx ²	Fb/EJ	-1/2Fx ² /b	1	(-1/6+1)Fb ² /EJ	Xb/EJ
FC	C	-1+x/b	1/2Fb-1/2qx ²	-Fb/EJ	-1/2Fb+1/2Fx+1/2Fx ² /b-1/2qx ³ /b	0	1-2x/b+x ² /b ²	1/3Xb/EJ
CF	F	x/b	-Fx+1/2qx ²	0	-Fx ² /b+1/2qx ³ /b	0	x ² /b ²	1/3Xb/EJ
totali								
								5/8Fb ² /EJ
								5/3Xb/EJ
								-3/8Fb

Quadro contributi PLV per iperstatica X=W^{EP}

Sviluppi di calcolo iperstatica

$$L_{DE}^{xx} = \int_0^b (x^2/b^2) 1/EJ dx = [1/3 x^3/b^2]_0^b 1/EJ$$

$$= (1/3 b) 1/EJ = 1/3 b/EJ$$

$$L_{ED}^{xx} = \int_0^b (1 - 2x/b + x^2/b^2) 1/EJ dx = [x - x^2/b + 1/3 x^3/b^2]_0^b 1/EJ$$

$$= (b - b + 1/3 b) 1/EJ = 1/3 b/EJ$$

$$L_{EF}^{xx} = \int_0^b (1) 1/EJ dx = [x]_0^b 1/EJ$$

$$= (b) 1/EJ = b/EJ$$

$$L_{FE}^{xx} = \int_0^b (1) 1/EJ dx = [x]_0^b 1/EJ$$

$$= (b) 1/EJ = b/EJ$$

$$L_{FC}^{xx} = \int_0^b (1 - 2x/b + x^2/b^2) 1/EJ dx = [x - x^2/b + 1/3 x^3/b^2]_0^b 1/EJ$$

$$= (b - b + 1/3 b) 1/EJ = 1/3 b/EJ$$

$$L_{CF}^{xx} = \int_0^b (x^2/b^2) 1/EJ dx = [1/3 x^3/b^2]_0^b 1/EJ$$

$$= (1/3 b) 1/EJ = 1/3 b/EJ$$

$$L_{EF}^{x0} = \int_0^b (-1/2 x^2/b^2) Fb 1/EJ dx + \int_0^b (1) \theta dx = [-1/6 x^3/b^2]_0^b Fb 1/EJ + [x]_0^b \theta$$

$$= (-1/6 b) Fb 1/EJ + (b) \theta = 5/6 Fb^2/EJ$$

$$L_{FE}^{x0} = \int_0^b (-1/2 + x/b - 1/2 x^2/b^2) Fb 1/EJ dx + \int_0^b (-1) \theta dx$$

$$= [-1/2 x + 1/2 x^2/b - 1/6 x^3/b^2]_0^b Fb 1/EJ + [-x]_0^b \theta$$

$$= (-1/2 b + 1/2 b - 1/6 b) Fb 1/EJ + (-b) \theta = 5/6 Fb^2/EJ$$

$$L_{FC}^{x0} = \int_0^b (-1/2 + 1/2 x/b + 1/2 x^2/b^2 - 1/2 x^3/b^3) Fb 1/EJ dx$$

$$= [-1/2 x + 1/4 x^2/b + 1/6 x^3/b^2 - 1/8 x^4/b^3]_0^b Fb 1/EJ$$

$$= (-1/2 b + 1/4 b + 1/6 b - 1/8 b) Fb 1/EJ = -5/24 Fb^2/EJ$$

$$L_{CF}^{x0} = \int_0^b (-x^2/b^2 + 1/2 x^3/b^3) Fb 1/EJ dx = [-1/3 x^3/b^2 + 1/8 x^4/b^3]_0^b Fb 1/EJ$$

$$= (-1/3 b + 1/8 b) Fb 1/EJ = -5/24 Fb^2/EJ$$

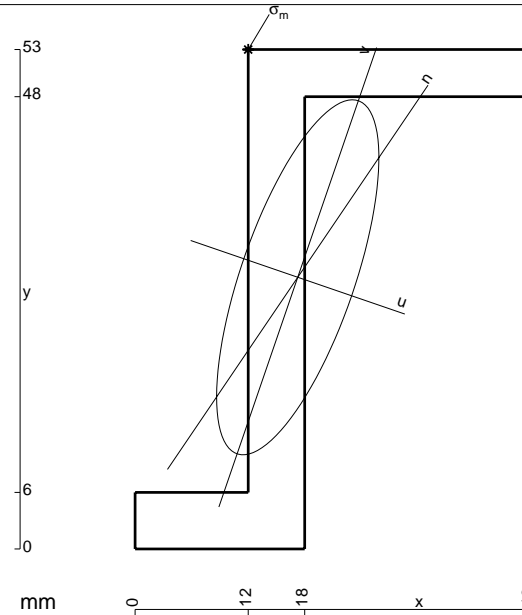

- A = 510. mm²
- J_x = 181019. mm⁴
- J_y = 37808. mm⁴
- J_{xy} = 55745. mm⁴
- J_u = 200159. mm⁴
- J_v = 18668. mm⁴
- α = arctg(2J_{xy}/(J_y-J_x))/2 = -.3307
- c = cos α = .9458
- s = sin α = -.3247
- x_g = 17.26 mm
- y_g = 28.83 mm
- N = -1288. N
- T_y = -644. N
- M_x = 734400. Nmm
- x_m = 12. mm
- y_m = 53. mm
- u_m = -12.82 mm
- v_m = 21.15 mm
- σ_m = N/A - Mcv/J_u - Msu/J_v = -239.8 N/mm²

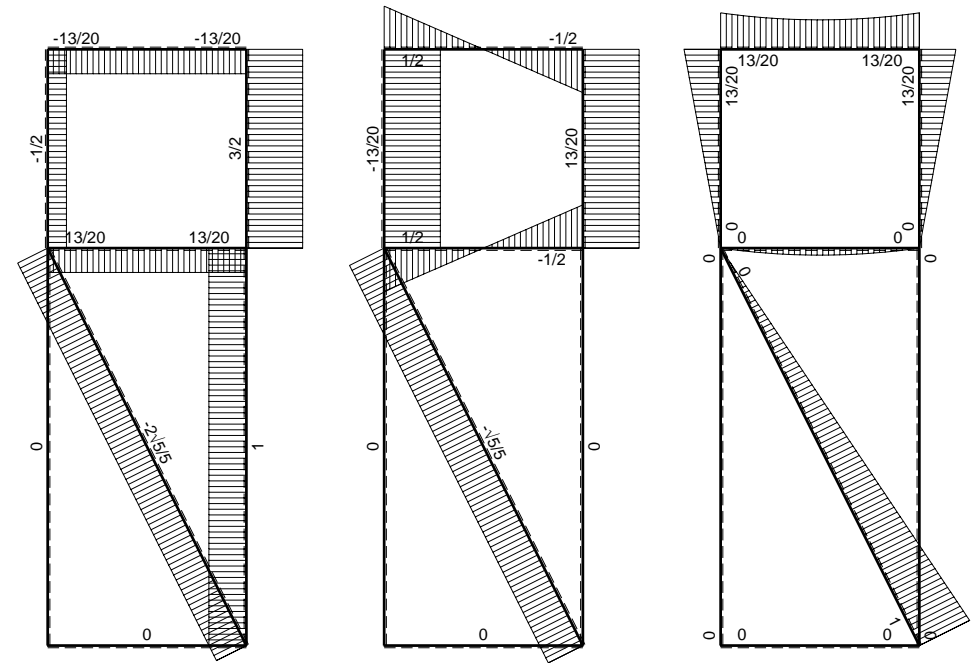
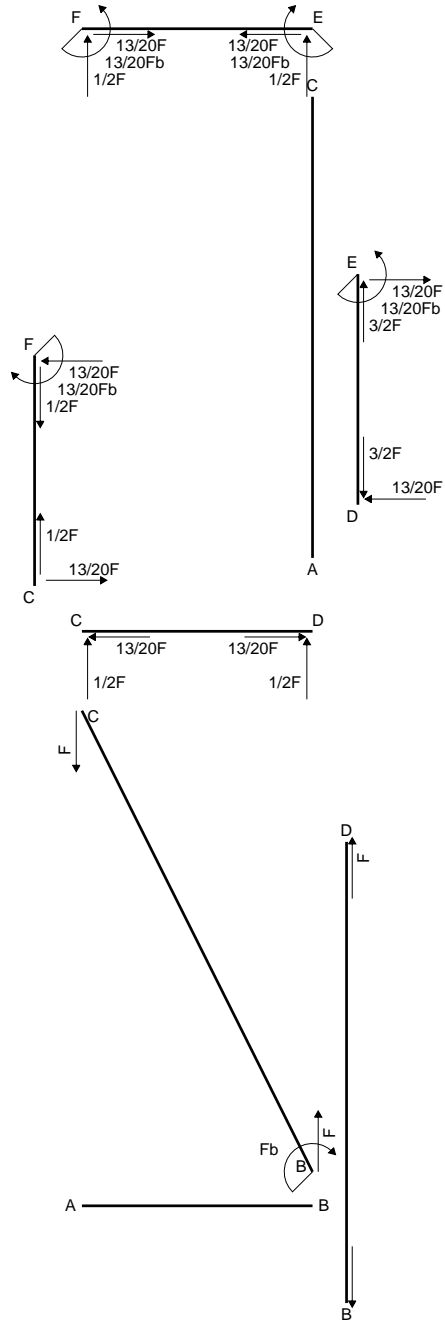

← ⊕ → F

↑ ⊕ ↓ F

⊕ ⊖ F_b

$$L_{DE}^{xx} = \int_0^b (x^2/b^2) 1/EJ dx = [1/3 x^3/b^2]_0^b 1/EJ$$

$$= (1/3 b) 1/EJ = 1/3 b/EJ$$

$$L_{ED}^{xx} = \int_0^b (1 - 2x/b + x^2/b^2) 1/EJ dx = [x - x^2/b + 1/3 x^3/b^2]_0^b 1/EJ$$

$$= (b - b + 1/3 b) 1/EJ = 1/3 b/EJ$$

$$L_{EF}^{xx} = \int_0^b (1) 1/EJ dx = [x]_0^b 1/EJ$$

$$= (b) 1/EJ = b/EJ$$

$$L_{FE}^{xx} = \int_0^b (1) 1/EJ dx = [x]_0^b 1/EJ$$

$$= (b) 1/EJ = b/EJ$$

$$L_{FC}^{xx} = \int_0^b (1 - 2x/b + x^2/b^2) 1/EJ dx = [x - x^2/b + 1/3 x^3/b^2]_0^b 1/EJ$$

$$= (b - b + 1/3 b) 1/EJ = 1/3 b/EJ$$

$$L_{CF}^{xx} = \int_0^b (x^2/b^2) 1/EJ dx = [1/3 x^3/b^2]_0^b 1/EJ$$

$$= (1/3 b) 1/EJ = 1/3 b/EJ$$

$$L_{EF}^{x\theta} = \int_0^b (1/2 x/b - 1/2 x^2/b^2) Fb 1/EJ dx + \int_0^b (1) \theta dx = [1/4 x^2/b - 1/6 x^3/b^2]_0^b Fb 1/EJ + [x]_0^b \theta$$

$$= (1/4 b - 1/6 b) Fb 1/EJ + (b) \theta = 13/12 Fb^2/EJ$$

$$L_{FE}^{x\theta} = \int_0^b (1/2 x/b - 1/2 x^2/b^2) Fb 1/EJ dx + \int_0^b (-1) \theta dx = [1/4 x^2/b - 1/6 x^3/b^2]_0^b Fb 1/EJ + [-x]_0^b \theta$$

$$= (1/4 b - 1/6 b) Fb 1/EJ + (-b) \theta = 13/12 Fb^2/EJ$$

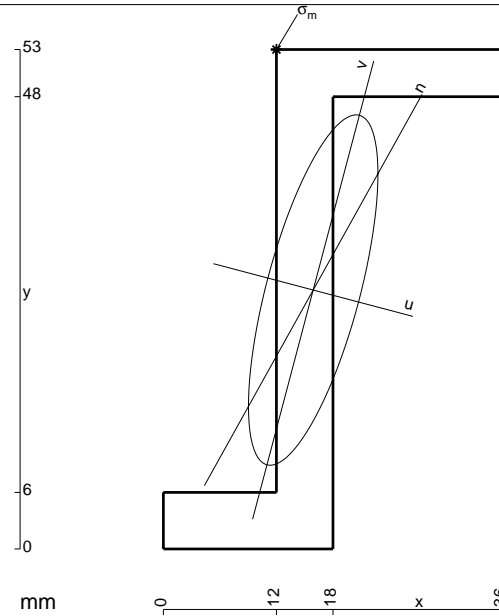

- A = 480. mm²
- J_x = 165988. mm⁴
- J_y = 22651. mm⁴
- J_{xy} = 40727. mm⁴
- J_u = 176751. mm⁴
- J_v = 11888. mm⁴
- α = arctg(2J_{xy}/(J_y-J_x))/2 = -.2584
- c = cos α = .9668
- s = sin α = -.2555
- x_g = 15.9 mm
- y_g = 27.48 mm
- N = -912.3 N
- T_y = -456.2 N
- M_x = 561000. Nmm
- x_m = 12. mm
- y_m = 53. mm
- u_m = -10.29 mm
- v_m = 23.68 mm
- σ_m = N/A - Mc_v/J_u - Ms_u/J_v = -198.7 N/mm²

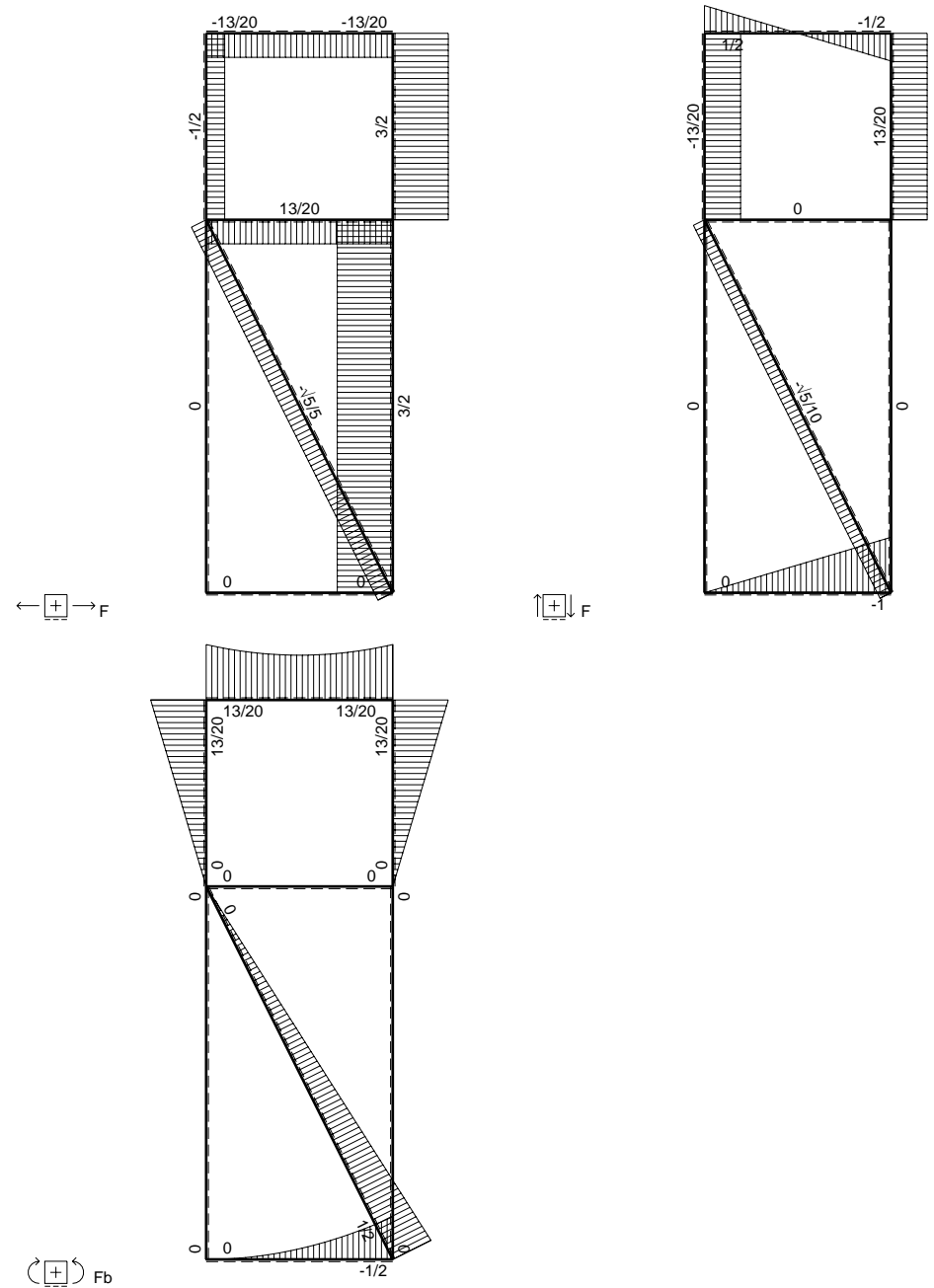
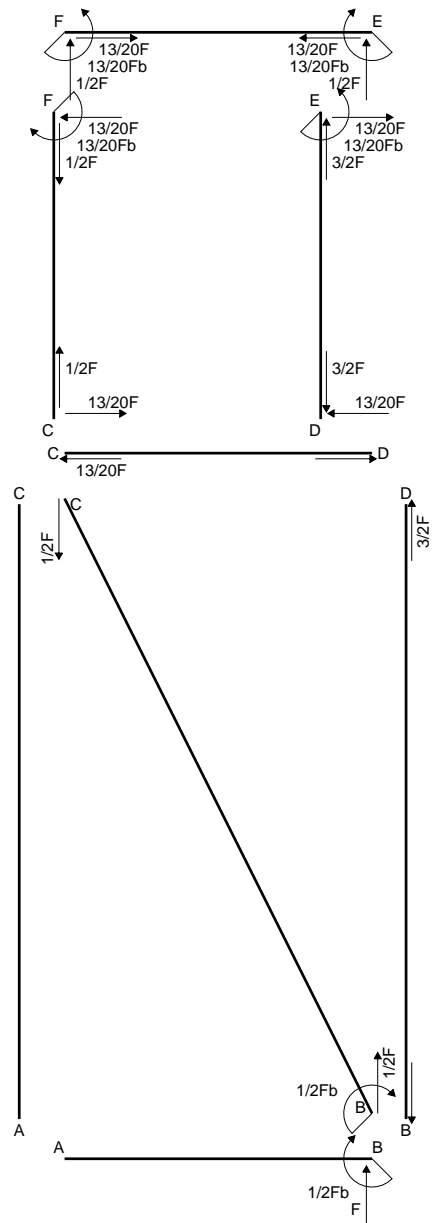

$$L_{DE}^{xx} = \int_0^b (x^2/b^2) 1/EJ dx = [1/3 x^3/b^2]_0^b 1/EJ$$

$$= (1/3 b) 1/EJ = 1/3 b/EJ$$

$$L_{ED}^{xx} = \int_0^b (1 - 2x/b + x^2/b^2) 1/EJ dx = [x - x^2/b + 1/3 x^3/b^2]_0^b 1/EJ$$

$$= (b - b + 1/3 b) 1/EJ = 1/3 b/EJ$$

$$L_{EF}^{xx} = \int_0^b (1) 1/EJ dx = [x]_0^b 1/EJ$$

$$= (b) 1/EJ = b/EJ$$

$$L_{FE}^{xx} = \int_0^b (1) 1/EJ dx = [x]_0^b 1/EJ$$

$$= (b) 1/EJ = b/EJ$$

$$L_{FC}^{xx} = \int_0^b (1 - 2x/b + x^2/b^2) 1/EJ dx = [x - x^2/b + 1/3 x^3/b^2]_0^b 1/EJ$$

$$= (b - b + 1/3 b) 1/EJ = 1/3 b/EJ$$

$$L_{CF}^{xx} = \int_0^b (x^2/b^2) 1/EJ dx = [1/3 x^3/b^2]_0^b 1/EJ$$

$$= (1/3 b) 1/EJ = 1/3 b/EJ$$

$$L_{EF}^{xo} = \int_0^b (1/2 x/b - 1/2 x^2/b^2) Fb 1/EJ dx + \int_0^b (1) \theta dx = [1/4 x^2/b - 1/6 x^3/b^2]_0^b Fb 1/EJ + [x]_0^b \theta$$

$$= (1/4 b - 1/6 b) Fb 1/EJ + (b) \theta = 13/12 Fb^2/EJ$$

$$L_{FE}^{xo} = \int_0^b (1/2 x/b - 1/2 x^2/b^2) Fb 1/EJ dx + \int_0^b (-1) \theta dx = [1/4 x^2/b - 1/6 x^3/b^2]_0^b Fb 1/EJ + [-x]_0^b \theta$$

$$= (1/4 b - 1/6 b) Fb 1/EJ + (-b) \theta = 13/12 Fb^2/EJ$$

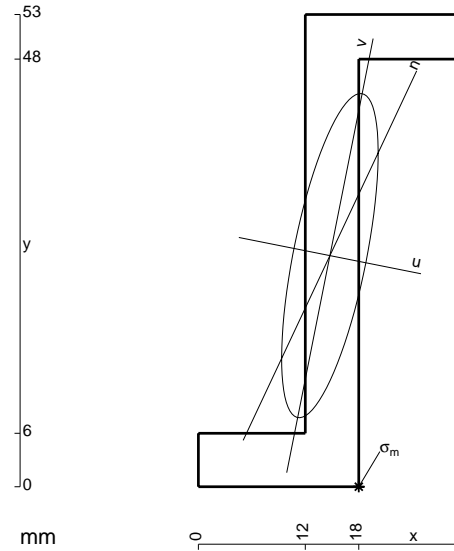

$$A = 450. \text{ mm}^2$$

$$J_x = 148960. \text{ mm}^4$$

$$J_y = 13204. \text{ mm}^4$$

$$J_{xy} = 28128. \text{ mm}^4$$

$$J_u = 154557. \text{ mm}^4$$

$$J_v = 7607. \text{ mm}^4$$

$$\alpha = \text{artg}(2J_{xy}/(J_y - J_x))/2 = -.1964$$

$$c = \cos \alpha = .9808$$

$$s = \sin \alpha = -.1952$$

$$x_g = 14.76 \text{ mm}$$

$$y_g = 25.94 \text{ mm}$$

$$N = 2175. \text{ N}$$

$$T_y = 942.5 \text{ N}$$

$$M_x = 556075. \text{ Nmm}$$

$$x_m = 18. \text{ mm}$$

$$u_m = 8.24 \text{ mm}$$

$$v_m = -24.81 \text{ mm}$$

$$\sigma_m = N/A - Mcv/J_u - Msu/J_v = 209.9 \text{ N/mm}^2$$

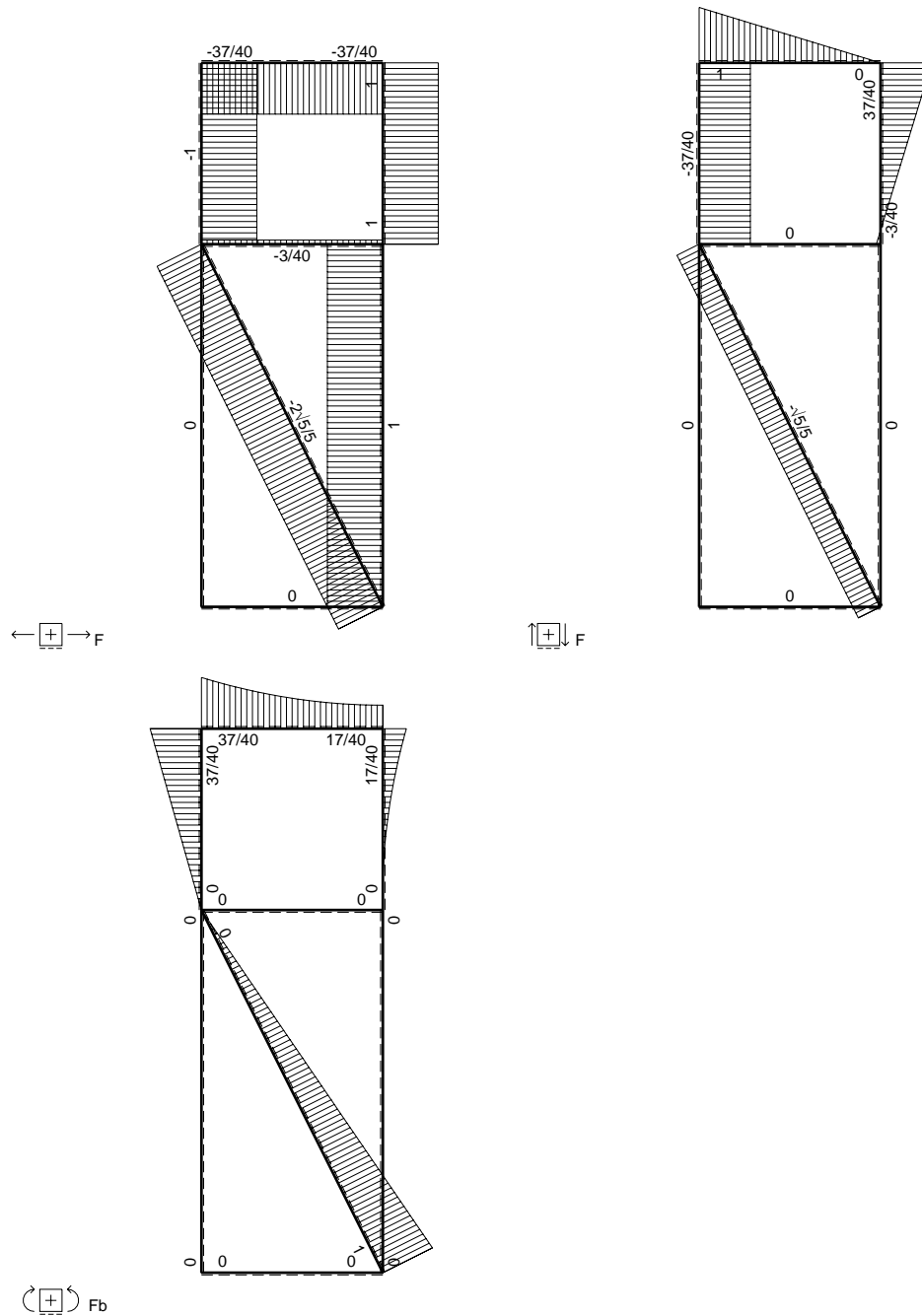
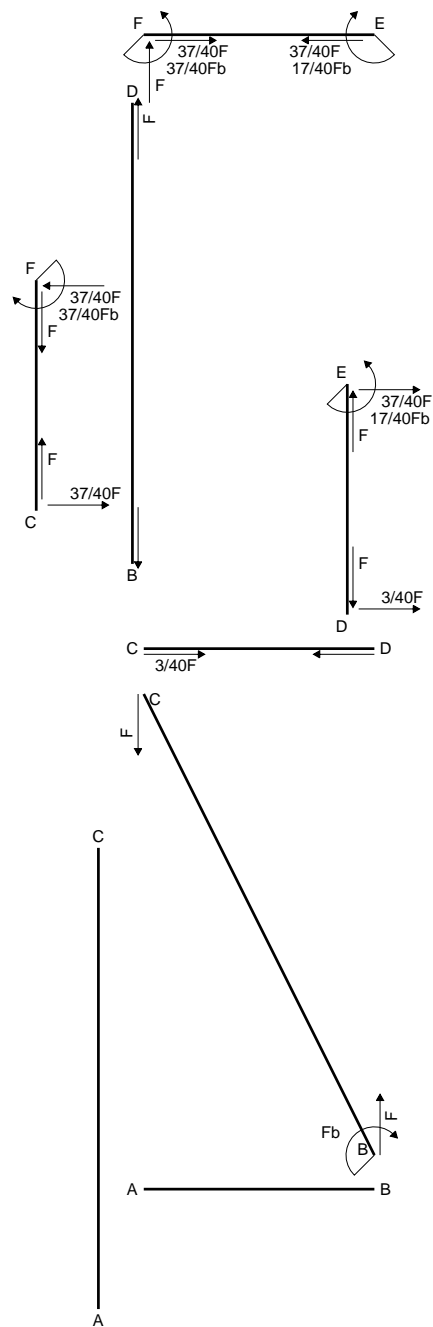

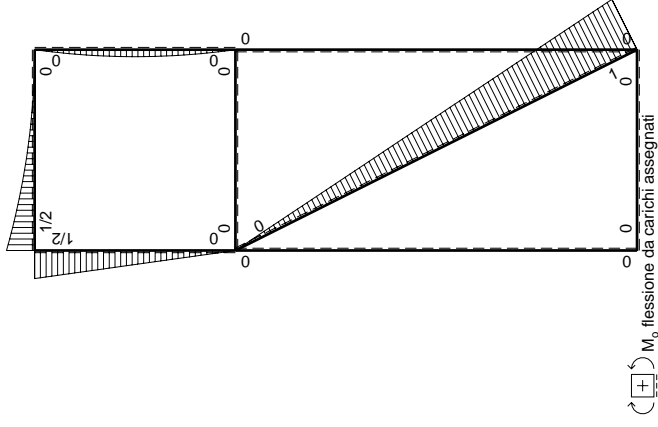
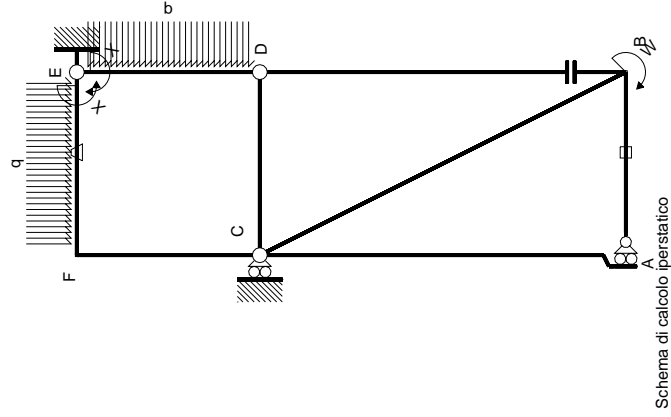

Quadro contributi PLV per iperstatica $X=W_{EF}$

\leftarrow	$M^x(x)$	$M^0(x)$	θ	$M^x M_0$	$M^x \theta$	$M^x M_x$	$\int M^x (M_0/EJ + \theta) dx$	$\int M^x M_x / E J dx$
AB b	0	0	0	0	0	0	0+0	0
BA b	0	0	0	0	0	0	0	0
BC $\sqrt{5}b$	0	$Fb\sqrt{5}/5Fx$	0	0	0	0	0+0	0
CA 2b	0	0	0	0	0	0	0+0	0
DB 2b	0	0	0	0	0	0	0+0	0
BD 2b	0	0	0	0	0	0	0+0	0
DE b	$-x/b$	$-1/2Fx + 1/2qx^2$	0	$1/2Fx^2/b - 1/2qx^3/b$	0	0	x^2/b^2	$1/3Xb/EJ$
ED b	$1-x/b$	$1/2Fx - 1/2qx^2$	0	$1/2Fx - Fx^2/b + 1/2qx^3/b$	0	0	$1-2x/b + x^2/b^2$	$1/3Xb/EJ$
CD b	0	0	0	0	0	0	0+0	0
DC b	0	0	0	0	0	0	0+0	0
EF b	-1	$1/2qx^2$	$-Fb/EJ$	$-1/2Fx^2/b$	Fb/EJ	1	$(-1/6+1)Fb^2/EJ$	Xb/EJ
FE b	1	$-1/2Fb + Fx - 1/2qx^2$	Fb/EJ	$-1/2Fb + Fx - 1/2Fx^2/b$	Fb/EJ	1	$(-1/6+0)Fb^2/EJ$	Xb/EJ
FC b	$-1+x/b$	$1/2Fb - 1/2Fx$	0	$-1/2Fb + Fx - 1/2Fx^2/b$	0	0	x^2/b^2	$1/3Xb/EJ$
CF b	x/b	$-1/2Fx$	0	$-1/2Fx^2/b$	0	0	x^2/b^2	$1/3Xb/EJ$
totali							$17/24Fb^2/EJ$	$5/3Xb/EJ$
							$-17/40Fb$	

Sviluppi di calcolo iperstatica

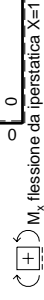

$$L_{DE}^{xx} = \int_0^b (x^2/b^2) 1/EJ dx = [1/3 x^3/b^2]_0^b 1/EJ$$

$$= (1/3 b) 1/EJ = 1/3 b/EJ$$

$$L_{ED}^{xx} = \int_0^b (1 - 2x/b + x^2/b^2) 1/EJ dx = [x - x^2/b + 1/3 x^3/b^2]_0^b 1/EJ$$

$$= (b - b + 1/3 b) 1/EJ = 1/3 b/EJ$$

$$L_{EF}^{xx} = \int_0^b (1) 1/EJ dx = [x]_0^b 1/EJ$$

$$= (b) 1/EJ = b/EJ$$

$$L_{FE}^{xx} = \int_0^b (1) 1/EJ dx = [x]_0^b 1/EJ$$

$$= (b) 1/EJ = b/EJ$$

$$L_{FC}^{xx} = \int_0^b (1 - 2x/b + x^2/b^2) 1/EJ dx = [x - x^2/b + 1/3 x^3/b^2]_0^b 1/EJ$$

$$= (b - b + 1/3 b) 1/EJ = 1/3 b/EJ$$

$$L_{CF}^{xx} = \int_0^b (x^2/b^2) 1/EJ dx = [1/3 x^3/b^2]_0^b 1/EJ$$

$$= (1/3 b) 1/EJ = 1/3 b/EJ$$

$$L_{DE}^{xo} = \int_0^b (1/2 x^2/b^2 - 1/2 x^3/b^3) Fb 1/EJ dx = [1/6 x^3/b^2 - 1/8 x^4/b^3]_0^b Fb 1/EJ$$

$$= (1/6 b - 1/8 b) Fb 1/EJ = 1/24 Fb^2/EJ$$

$$L_{ED}^{xo} = \int_0^b (1/2 x/b - x^2/b^2 + 1/2 x^3/b^3) Fb 1/EJ dx = [1/4 x^2/b - 1/3 x^3/b^2 + 1/8 x^4/b^3]_0^b Fb 1/EJ$$

$$= (1/4 b - 1/3 b + 1/8 b) Fb 1/EJ = 1/24 Fb^2/EJ$$

$$L_{EF}^{xo} = \int_0^b (-1/2 x^2/b^2) Fb 1/EJ dx + \int_0^b (1) \theta dx = [-1/6 x^3/b^2]_0^b Fb 1/EJ + [x]_0^b \theta$$

$$= (-1/6 b) Fb 1/EJ + (b) \theta = 5/6 Fb^2/EJ$$

$$L_{FE}^{xo} = \int_0^b (-1/2 + x/b - 1/2 x^2/b^2) Fb 1/EJ dx + \int_0^b (-1) \theta dx$$

$$= [-1/2 x + 1/2 x^2/b - 1/6 x^3/b^2]_0^b Fb 1/EJ + [-x]_0^b \theta$$

$$= (-1/2 b + 1/2 b - 1/6 b) Fb 1/EJ + (-b) \theta = 5/6 Fb^2/EJ$$

$$L_{FC}^{xo} = \int_0^b (-1/2 + x/b - 1/2 x^2/b^2) Fb 1/EJ dx = [-1/2 x + 1/2 x^2/b - 1/6 x^3/b^2]_0^b Fb 1/EJ$$

$$= (-1/2 b + 1/2 b - 1/6 b) Fb 1/EJ = -1/6 Fb^2/EJ$$

$$L_{CF}^{xo} = \int_0^b (-1/2 x^2/b^2) Fb 1/EJ dx = [-1/6 x^3/b^2]_0^b Fb 1/EJ$$

$$= (-1/6 b) Fb 1/EJ = -1/6 Fb^2/EJ$$

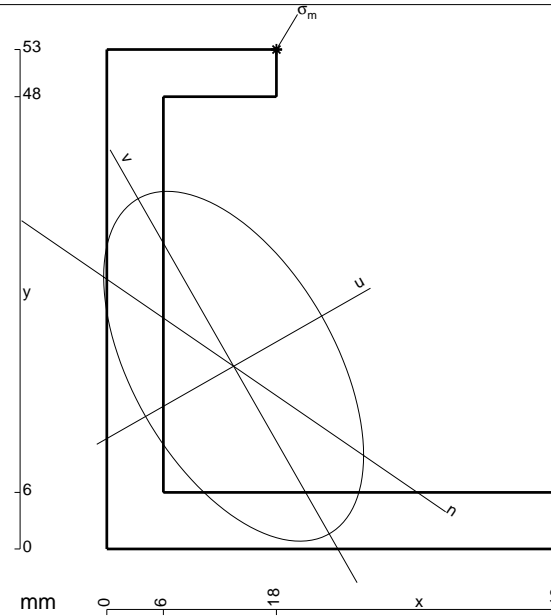

- A = 630. mm²
- J_x = 217160. mm⁴
- J_y = 119838. mm⁴
- J_{xy} = -82299. mm⁴
- J_u = 264108. mm⁴
- J_v = 72891. mm⁴
- α = arctg(2J_{xy}/(J_y-J_x))/2 = .5184
- c = cos α = .8686
- s = sin α = .4955
- x_g = 13.46 mm
- y_g = 19.39 mm
- N = -1368. N
- T_y = -684.2 N
- M_x = 948600. Nmm
- x_m = 18. mm
- y_m = 53. mm
- u_m = 20.6 mm
- v_m = 26.95 mm
- σ_m = N/A - Mc_v/J_u - Ms_u/J_v = -219.1 N/mm²

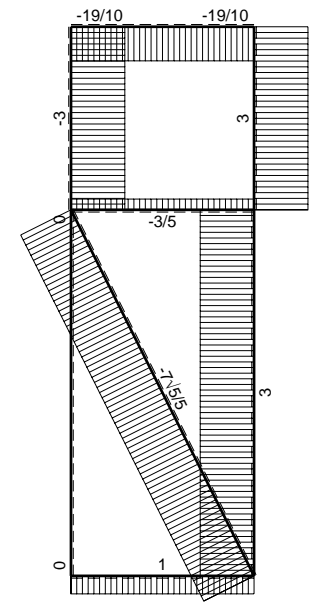
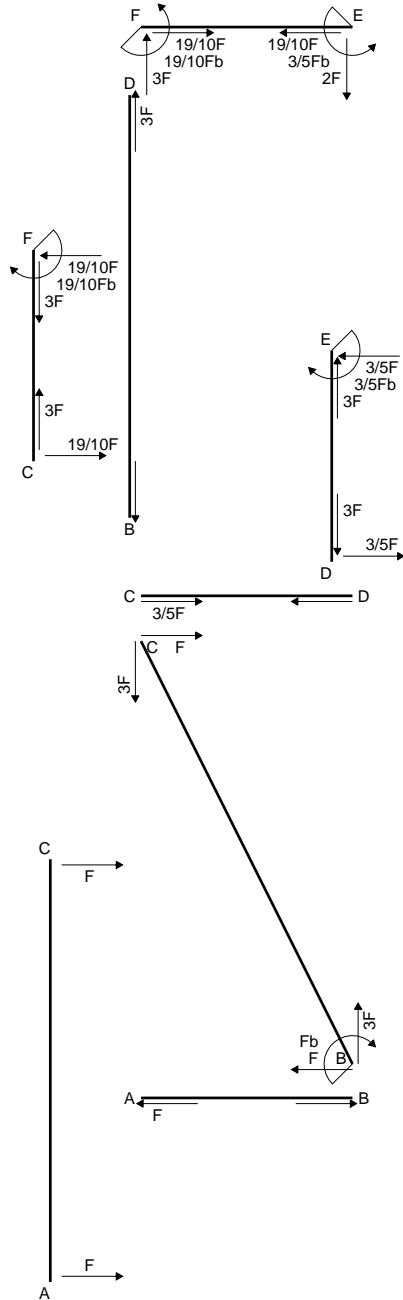

← ⊕ → F

↑ ⊕ ↓ F

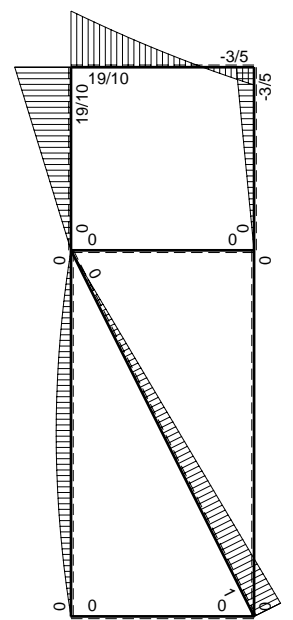

⊕ ⊖ F_b

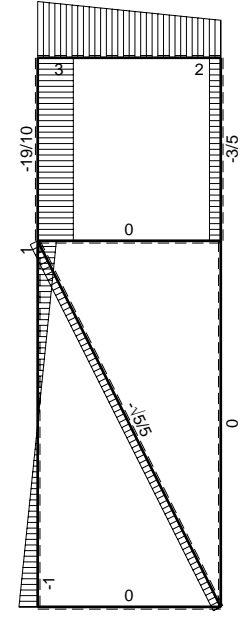

$$L_{DE}^{xx} = \int_0^b (x^2/b^2) 1/EJ dx = [1/3 x^3/b^2]_0^b 1/EJ$$

$$= (1/3 b) 1/EJ = 1/3 b/EJ$$

$$L_{ED}^{xx} = \int_0^b (1 - 2x/b + x^2/b^2) 1/EJ dx = [x - x^2/b + 1/3 x^3/b^2]_0^b 1/EJ$$

$$= (b - b + 1/3 b) 1/EJ = 1/3 b/EJ$$

$$L_{EF}^{xx} = \int_0^b (1) 1/EJ dx = [x]_0^b 1/EJ$$

$$= (b) 1/EJ = b/EJ$$

$$L_{FE}^{xx} = \int_0^b (1) 1/EJ dx = [x]_0^b 1/EJ$$

$$= (b) 1/EJ = b/EJ$$

$$L_{FC}^{xx} = \int_0^b (1 - 2x/b + x^2/b^2) 1/EJ dx = [x - x^2/b + 1/3 x^3/b^2]_0^b 1/EJ$$

$$= (b - b + 1/3 b) 1/EJ = 1/3 b/EJ$$

$$L_{CF}^{xx} = \int_0^b (x^2/b^2) 1/EJ dx = [1/3 x^3/b^2]_0^b 1/EJ$$

$$= (1/3 b) 1/EJ = 1/3 b/EJ$$

$$L_{EF}^{x\theta} = \int_0^b (-2x/b - 1/2 x^2/b^2) Fb 1/EJ dx + \int_0^b (1) \theta dx = [-x^2/b - 1/6 x^3/b^2]_0^b Fb 1/EJ + [x]_0^b \theta$$

$$= (-b - 1/6 b) Fb 1/EJ + (b) \theta = -1/6 Fb^2/EJ$$

$$L_{FE}^{x\theta} = \int_0^b (-5/2 + 3x/b - 1/2 x^2/b^2) Fb 1/EJ dx + \int_0^b (-1) \theta dx$$

$$= [-5/2 x + 3/2 x^2/b - 1/6 x^3/b^2]_0^b Fb 1/EJ + [-x]_0^b \theta$$

$$= (-5/2 b + 3/2 b - 1/6 b) Fb 1/EJ + (-b) \theta = -1/6 Fb^2/EJ$$

$$L_{FC}^{x\theta} = \int_0^b (-5/2 + 5x/b - 5/2 x^2/b^2) Fb 1/EJ dx = [-5/2 x + 5/2 x^2/b - 5/6 x^3/b^2]_0^b Fb 1/EJ$$

$$= (-5/2 b + 5/2 b - 5/6 b) Fb 1/EJ = -5/6 Fb^2/EJ$$

$$L_{CF}^{x\theta} = \int_0^b (-5/2 x^2/b^2) Fb 1/EJ dx = [-5/6 x^3/b^2]_0^b Fb 1/EJ$$

$$= (-5/6 b) Fb 1/EJ = -5/6 Fb^2/EJ$$

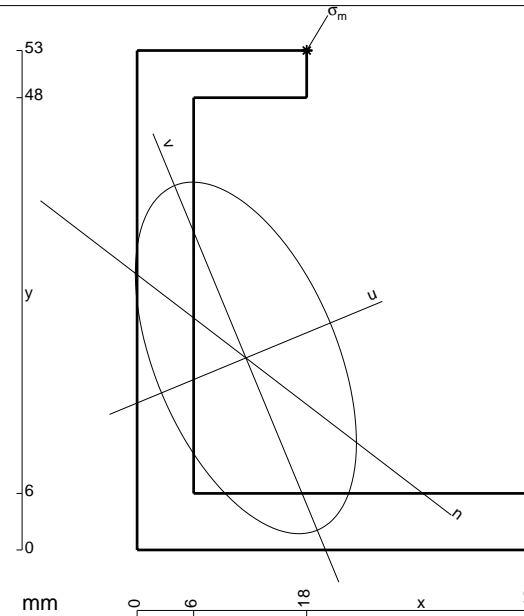

$A = 594. \text{ mm}^2$
 $J_x = 206801. \text{ mm}^4$
 $J_y = 81741. \text{ mm}^4$
 $J_{xy} = -62565. \text{ mm}^4$
 $J_u = 232726. \text{ mm}^4$
 $J_v = 55816. \text{ mm}^4$
 $\alpha = \text{artg}(2J_{xy}/(J_y - J_x))/2 = .3928$
 $c = \cos \alpha = .9238$
 $s = \sin \alpha = .3828$
 $x_g = 11.55 \text{ mm}$
 $y_g = 20.38 \text{ mm}$
 $N = -2280. \text{ N}$
 $T_y = -1444. \text{ N}$
 $M_x = 953040. \text{ Nmm}$
 $x_m = 18. \text{ mm}$
 $y_m = 53. \text{ mm}$
 $u_m = 18.45 \text{ mm}$
 $v_m = 27.67 \text{ mm}$
 $\sigma_m = N/A - Mcv/J_u - Msu/J_v = -229.1 \text{ N/mm}^2$

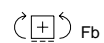
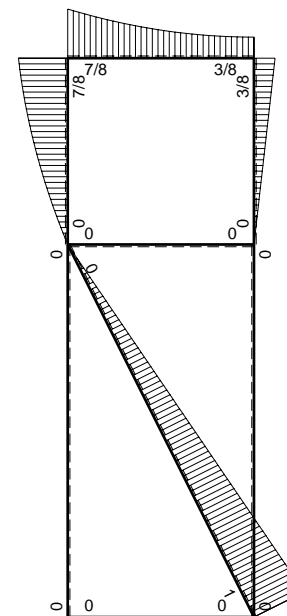
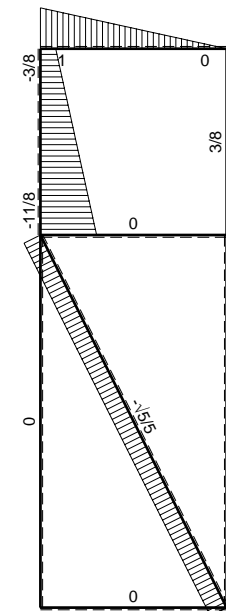
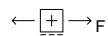
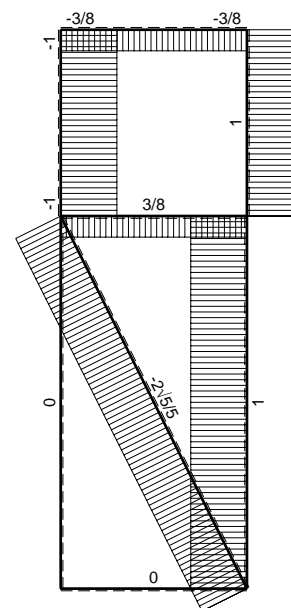
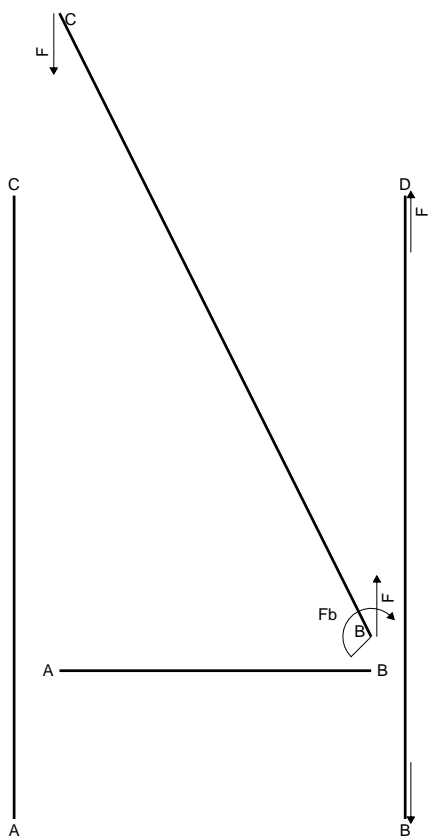
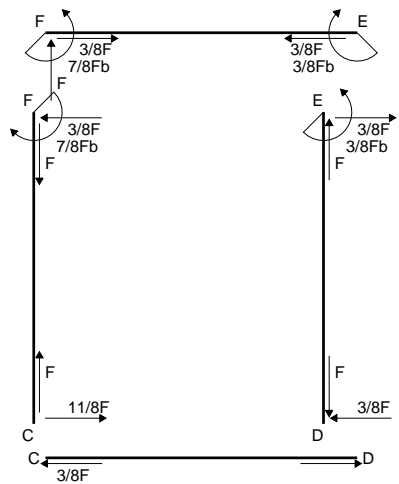

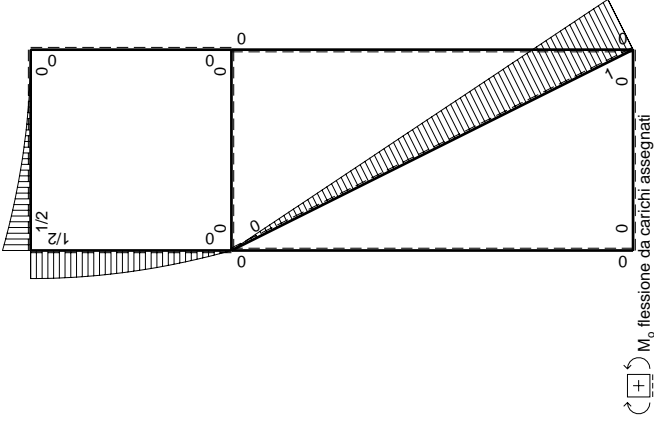
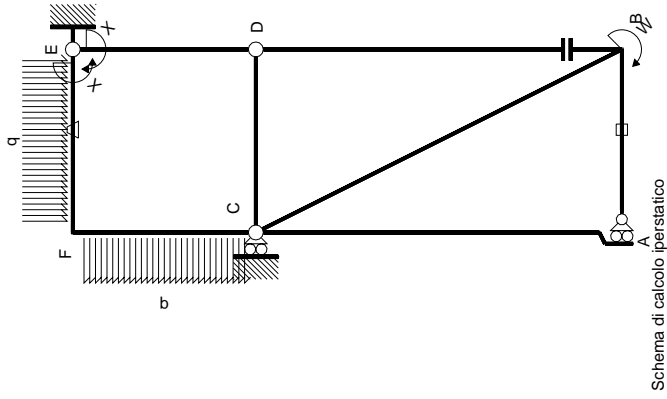

Quadro contributi PLV per iperstatica $X=W_{EF}$

\leftarrow	$M_x(x)$	$M_0(x)$	θ	M_x^0	M_x^{θ}	M_x^X	$\int M_x(M_0/EJ+\theta)dx$	$\int X M_x^0 M_x^{\theta} E dx$
AB B	0	0	0	0	0	0	0+0	0
BA B	0	0	0	0	0	0	0	0
BC $\sqrt{5}$ B	0	$Fb-\sqrt{5}/5Fx$	0	0	0	0	0+0	0
AC 2b	0	0	0	0	0	0	0+0	0
CA 2b	0	0	0	0	0	0	0+0	0
DB 2b	0	0	0	0	0	0	0+0	0
BD 2b	0	0	0	0	0	0	0+0	0
DE b	-x/b	0	0	0	0	x^2/b^2	0+0	0
ED b	1-x/b	0	0	0	0	$1-2x/b+x^2/b^2$	0+0	$1/3Xb/EJ$
CD b	0	0	0	0	0	0	0+0	0
DC b	0	0	0	0	0	0	0+0	0
EF b	-1	$1/2qx^2$	$-Fb/EJ$	$-1/2Fx^2/b$	Fb/EJ	1	$(-1/6+1)Fb^2/EJ$	Xb/EJ
FE b	1	$-1/2Fb+Fx-1/2qx^2$	Fb/EJ	$-1/2Fx^2/b$	Fb/EJ	1	$(-1/6+1)Fb^2/EJ$	Xb/EJ
FC b	$-1+x/b$	$1/2Fb-1/2qx^2$	0	$-1/2Fb+1/2Fx+1/2Fx^2/b-1/2qx^3/b$	0	$1-2x/b+x^2/b^2$	$(-5/24+0)Fb^2/EJ$	$1/3Xb/EJ$
CF b	x/b	$-Fx+1/2qx^2$	0	$-Fx^2/b+1/2qx^3/b$	0	x^2/b^2	$(-5/24+0)Fb^2/EJ$	$1/3Xb/EJ$
totali								$5/3Xb/EJ$
iperstatica $X=W_{EF}$								$-3/8Fb$

Sviluppi di calcolo iperstatica

$$L_{DE}^{xx} = \int_0^b (x^2/b^2) 1/EJ dx = [1/3 x^3/b^2]_0^b 1/EJ$$

$$= (1/3 b) 1/EJ = 1/3 b/EJ$$

$$L_{ED}^{xx} = \int_0^b (1 - 2x/b + x^2/b^2) 1/EJ dx = [x - x^2/b + 1/3 x^3/b^2]_0^b 1/EJ$$

$$= (b - b + 1/3 b) 1/EJ = 1/3 b/EJ$$

$$L_{EF}^{xx} = \int_0^b (1) 1/EJ dx = [x]_0^b 1/EJ$$

$$= (b) 1/EJ = b/EJ$$

$$L_{FE}^{xx} = \int_0^b (1) 1/EJ dx = [x]_0^b 1/EJ$$

$$= (b) 1/EJ = b/EJ$$

$$L_{FC}^{xx} = \int_0^b (1 - 2x/b + x^2/b^2) 1/EJ dx = [x - x^2/b + 1/3 x^3/b^2]_0^b 1/EJ$$

$$= (b - b + 1/3 b) 1/EJ = 1/3 b/EJ$$

$$L_{CF}^{xx} = \int_0^b (x^2/b^2) 1/EJ dx = [1/3 x^3/b^2]_0^b 1/EJ$$

$$= (1/3 b) 1/EJ = 1/3 b/EJ$$

$$L_{EF}^{xo} = \int_0^b (-1/2 x^2/b^2) Fb 1/EJ dx + \int_0^b (1) \theta dx = [-1/6 x^3/b^2]_0^b Fb 1/EJ + [x]_0^b \theta$$

$$= (-1/6 b) Fb 1/EJ + (b) \theta = 5/6 Fb^2/EJ$$

$$L_{FE}^{xo} = \int_0^b (-1/2 + x/b - 1/2 x^2/b^2) Fb 1/EJ dx + \int_0^b (-1) \theta dx$$

$$= [-1/2 x + 1/2 x^2/b - 1/6 x^3/b^2]_0^b Fb 1/EJ + [-x]_0^b \theta$$

$$= (-1/2 b + 1/2 b - 1/6 b) Fb 1/EJ + (-b) \theta = 5/6 Fb^2/EJ$$

$$L_{FC}^{xo} = \int_0^b (-1/2 + 1/2 x/b + 1/2 x^2/b^2 - 1/2 x^3/b^3) Fb 1/EJ dx$$

$$= [-1/2 x + 1/4 x^2/b + 1/6 x^3/b^2 - 1/8 x^4/b^3]_0^b Fb 1/EJ$$

$$= (-1/2 b + 1/4 b + 1/6 b - 1/8 b) Fb 1/EJ = -5/24 Fb^2/EJ$$

$$L_{CF}^{xo} = \int_0^b (-x^2/b^2 + 1/2 x^3/b^3) Fb 1/EJ dx = [-1/3 x^3/b^2 + 1/8 x^4/b^3]_0^b Fb 1/EJ$$

$$= (-1/3 b + 1/8 b) Fb 1/EJ = -5/24 Fb^2/EJ$$

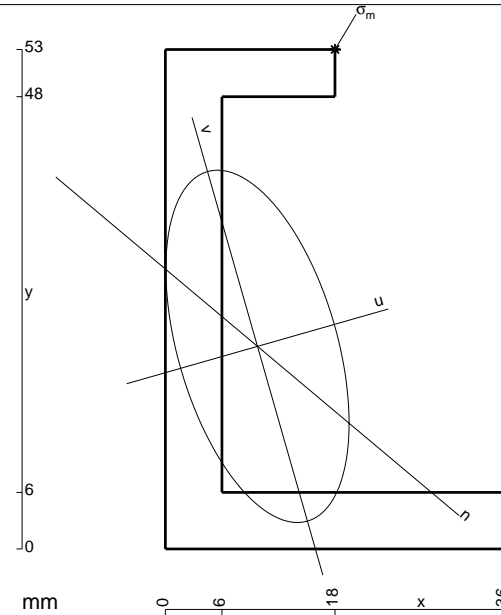

$A = 558. \text{ mm}^2$
 $J_x = 195119. \text{ mm}^4$
 $J_y = 52748. \text{ mm}^4$
 $J_{xy} = -44280. \text{ mm}^4$
 $J_u = 207767. \text{ mm}^4$
 $J_v = 40099. \text{ mm}^4$
 $\alpha = \text{artg}(2J_{xy}/(J_y - J_x))/2 = .2782$
 $c = \cos \alpha = .9615$
 $s = \sin \alpha = .2747$
 $x_g = 9.774 \text{ mm}$
 $y_g = 21.5 \text{ mm}$
 $N = -1243. \text{ N}$
 $T_y = -621.6 \text{ N}$
 $M_x = 973000. \text{ Nmm}$
 $x_m = 18. \text{ mm}$
 $y_m = 53. \text{ mm}$
 $u_m = 16.56 \text{ mm}$
 $v_m = 28.03 \text{ mm}$
 $\sigma_m = N/A - Mcv/J_u - Msu/J_v = -238.8 \text{ N/mm}^2$

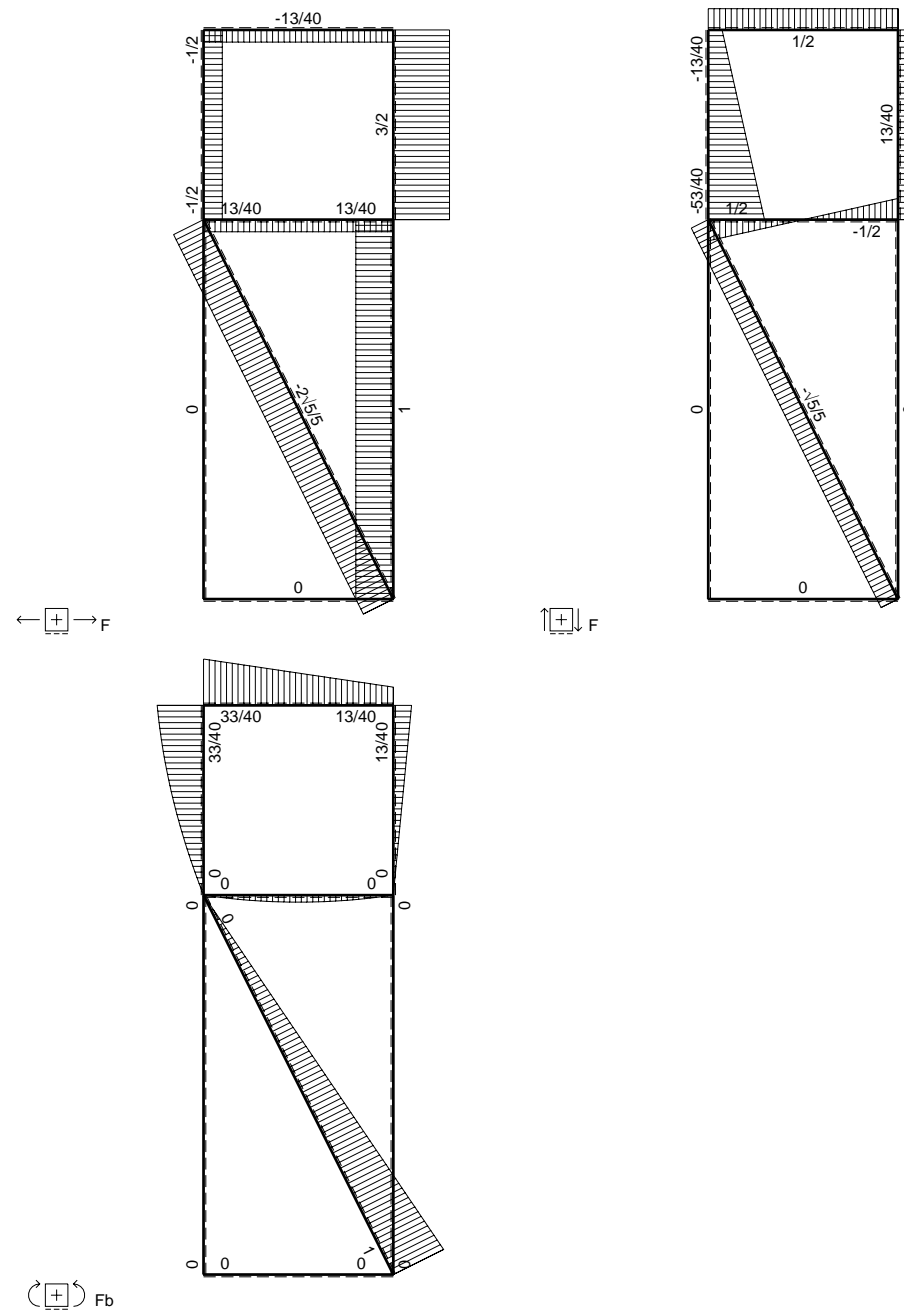
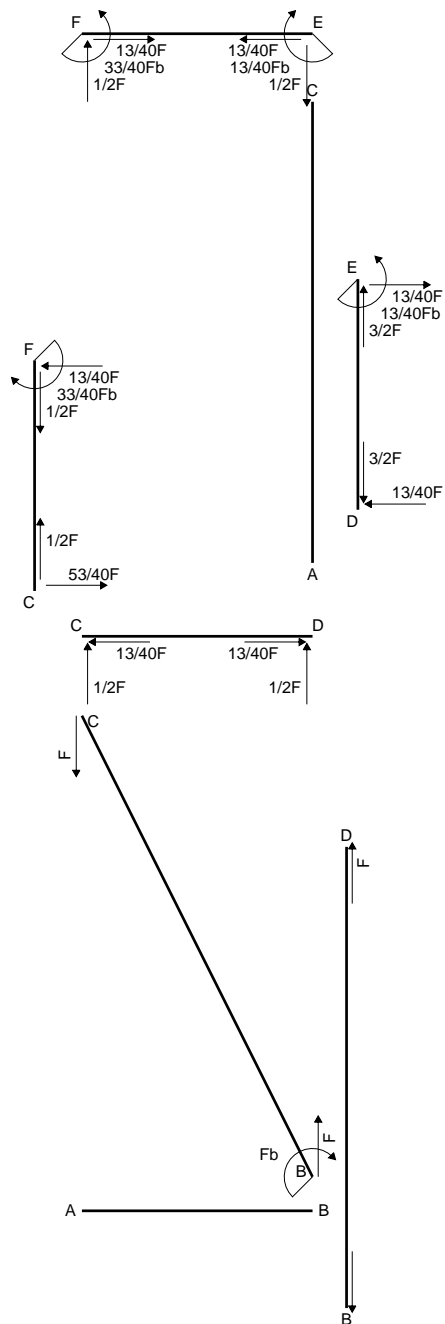

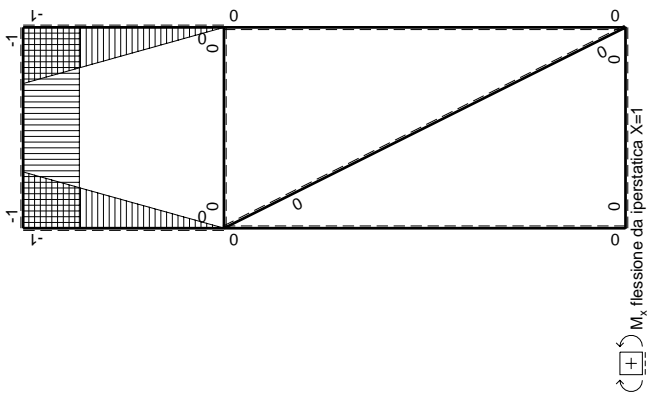
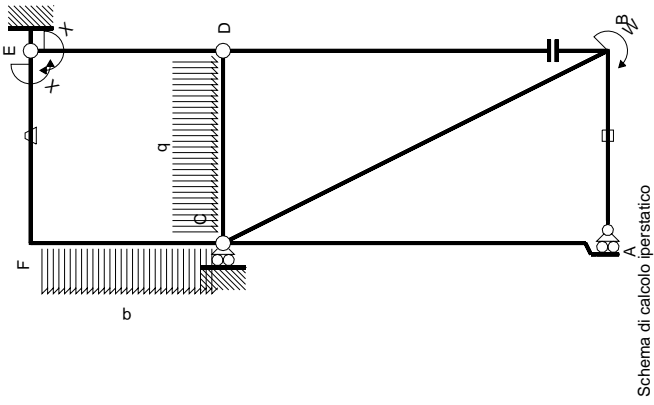

Quadro contributi PLV per iperstatica $X=W_{EP}$

\leftarrow	$M(x)$	$M_0(x)$	M_x	M_θ	M_x	$\int M_x(M_0/EJ+\theta)dx$	$\int M_x M_x/EJdx$
AB b	0	0	0	0	0	0	0
BA b	0	0	0	0	0	0	0
BC $\sqrt{5}b$	$Fb-\sqrt{5}Fx$	0	0	0	0	0	0
CA 2b	0	0	0	0	0	0	0
AC 2b	0	0	0	0	0	0	0
DB 2b	0	0	0	0	0	0	0
BD 2b	0	0	0	0	0	0	0
DE b	-x/b	0	0	0	x^2/b^2	0	0
ED b	1-x/b	0	0	0	$1-2x/b+x^2/b^2$	0	0
CD b	$1/2Fx-1/2qx^2$	0	0	0	0	0	0
DC b	$-1/2Fx+1/2qx^2$	0	0	0	0	0	0
EF b	-1	$-1/2Fx$	$-Fb/EJ$	$-1/2Fx$	Fb/EJ	1	Fb/EJ
FE b	1	$-1/2Fb+1/2Fx$	Fb/EJ	$-1/2Fb+1/2Fx$	Fb/EJ	1	Fb/EJ
FC b	$-1+x/b$	$1/2Fb-1/2qx^2$	$-Fb/EJ$	$-1/2Fb+1/2Fx$	$1-2x/b+x^2/b^2$	0	0
CF b	x/b	$-Fx+1/2qx^2$	0	$-Fx^2/b+1/2qx^3/b$	0	0	0
totali							
						$13/24Fb^2/EJ$	$5/3Xb/EJ$
						$-13/40Fb$	

Sviluppi di calcolo iperstatica

$$L_{DE}^{xx} = \int_0^b (x^2/b^2) 1/EJ dx = [1/3 x^3/b^2]_0^b 1/EJ$$

$$= (1/3 b) 1/EJ = 1/3 b/EJ$$

$$L_{ED}^{xx} = \int_0^b (1 - 2x/b + x^2/b^2) 1/EJ dx = [x - x^2/b + 1/3 x^3/b^2]_0^b 1/EJ$$

$$= (b - b + 1/3 b) 1/EJ = 1/3 b/EJ$$

$$L_{EF}^{xx} = \int_0^b (1) 1/EJ dx = [x]_0^b 1/EJ$$

$$= (b) 1/EJ = b/EJ$$

$$L_{FE}^{xx} = \int_0^b (1) 1/EJ dx = [x]_0^b 1/EJ$$

$$= (b) 1/EJ = b/EJ$$

$$L_{FC}^{xx} = \int_0^b (1 - 2x/b + x^2/b^2) 1/EJ dx = [x - x^2/b + 1/3 x^3/b^2]_0^b 1/EJ$$

$$= (b - b + 1/3 b) 1/EJ = 1/3 b/EJ$$

$$L_{CF}^{xx} = \int_0^b (x^2/b^2) 1/EJ dx = [1/3 x^3/b^2]_0^b 1/EJ$$

$$= (1/3 b) 1/EJ = 1/3 b/EJ$$

$$L_{EF}^{xo} = \int_0^b (-1/2 x/b) Fb 1/EJ dx + \int_0^b (1) \theta dx = [-1/4 x^2/b]_0^b Fb 1/EJ + [x]_0^b \theta$$

$$= (-1/4 b) Fb 1/EJ + (b) \theta = 3/4 Fb^2/EJ$$

$$L_{FE}^{xo} = \int_0^b (-1/2 + 1/2 x/b) Fb 1/EJ dx + \int_0^b (-1) \theta dx = [-1/2 x + 1/4 x^2/b]_0^b Fb 1/EJ + [-x]_0^b \theta$$

$$= (-1/2 b + 1/4 b) Fb 1/EJ + (-b) \theta = 3/4 Fb^2/EJ$$

$$L_{FC}^{xo} = \int_0^b (-1/2 + 1/2 x/b + 1/2 x^2/b^2 - 1/2 x^3/b^3) Fb 1/EJ dx$$

$$= [-1/2 x + 1/4 x^2/b + 1/6 x^3/b^2 - 1/8 x^4/b^3]_0^b Fb 1/EJ$$

$$= (-1/2 b + 1/4 b + 1/6 b - 1/8 b) Fb 1/EJ = -5/24 Fb^2/EJ$$

$$L_{CF}^{xo} = \int_0^b (-x^2/b^2 + 1/2 x^3/b^3) Fb 1/EJ dx = [-1/3 x^3/b^2 + 1/8 x^4/b^3]_0^b Fb 1/EJ$$

$$= (-1/3 b + 1/8 b) Fb 1/EJ = -5/24 Fb^2/EJ$$

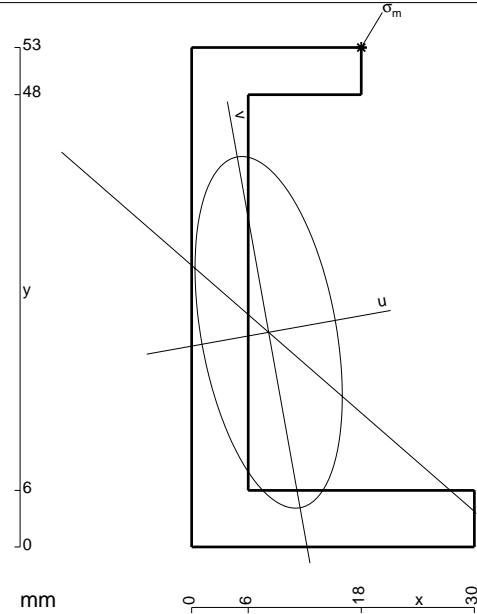

$A = 522. \text{ mm}^2$
 $J_x = 181840. \text{ mm}^4$
 $J_y = 31881. \text{ mm}^4$
 $J_{xy} = -27745. \text{ mm}^4$
 $J_u = 186808. \text{ mm}^4$
 $J_v = 26912. \text{ mm}^4$
 $\alpha = \text{artg}(2J_{xy}/(J_y - J_x))/2 = .1772$
 $c = \cos \alpha = .9843$
 $s = \sin \alpha = .1763$
 $x_g = 8.172 \text{ mm}$
 $y_g = 22.78 \text{ mm}$
 $N = -1923. \text{ N}$
 $T_y = -961.5 \text{ N}$
 $M_x = 795500. \text{ Nmm}$
 $x_m = 18. \text{ mm}$
 $y_m = 53. \text{ mm}$
 $u_m = 15. \text{ mm}$
 $v_m = 28.02 \text{ mm}$
 $\sigma_m = N/A - Mcv/J_u - Msu/J_v = -199.3 \text{ N/mm}^2$

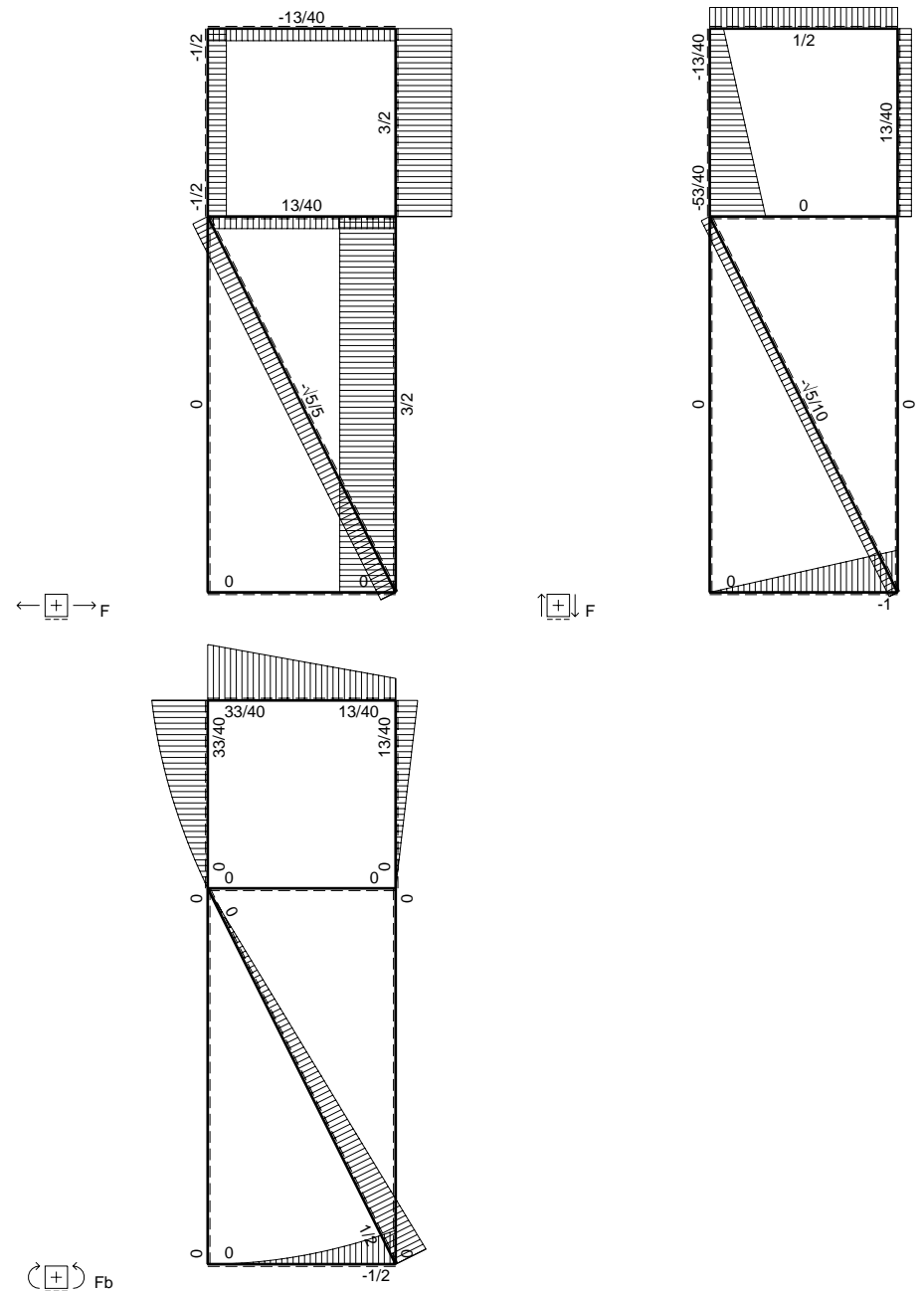
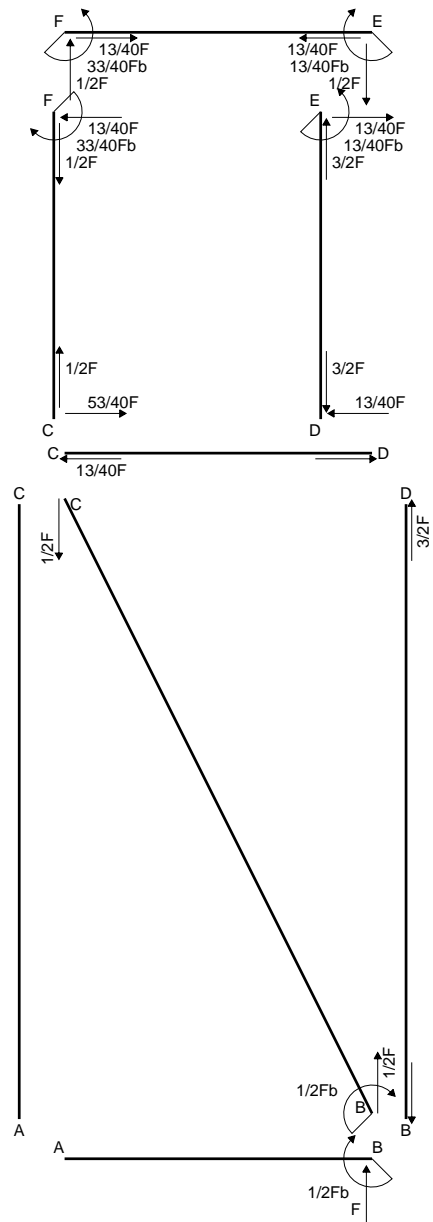

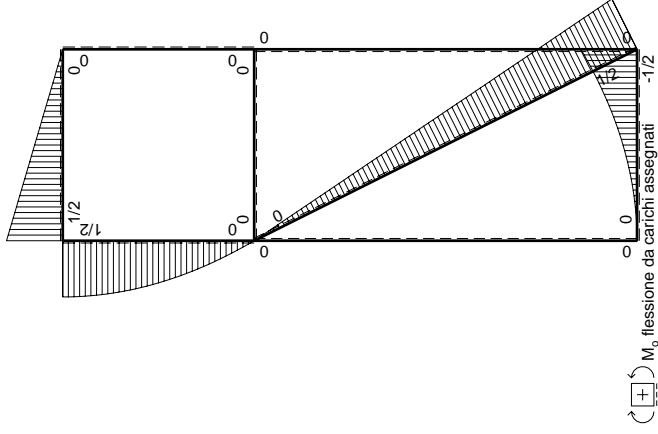
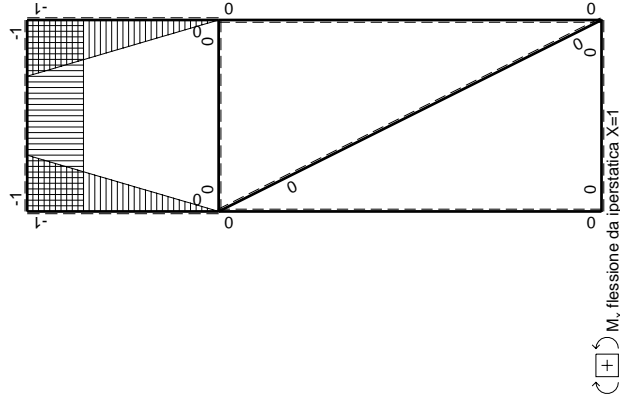
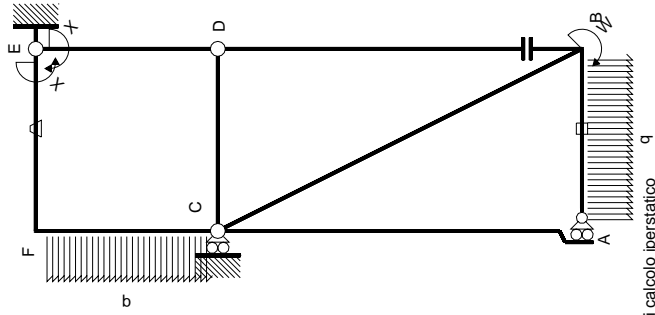

Quadro contributi PLV per iperstatica $X=W_{EF}$		$M_x(x)$		$M_0(x)$		$M_x \theta$	$M_x M_x$	$\int M_x(M_0/EJ+\theta)dx$	$\int M_x M_x/EJdx$
AB b	0	$-1/2qx^2$	0	0	0	0	0	0+0	0
BA b	0	$1/2Fb-Fx+1/2qx^2$	0	0	0	0	0	0	0
BC $\sqrt{5}b$	0	$1/2Fb-\sqrt{5}/10Fx$	0	0	0	0	0	0	0
AC 2b	0	0	0	0	0	0	0	0+0	0
CA 2b	0	0	0	0	0	0	0	0	0
DB 2b	0	0	0	0	0	0	0	0+0	0
BD 2b	0	0	0	0	0	0	0	0	0
DE b	-x/b	0	0	0	0	0	x^2/b^2	0+0	1/3Xb/EJ
ED b	1-x/b	0	0	0	0	0	$1-2x/b+x^2/b^2$	0+0	1/3Xb/EJ
CD b	0	0	0	0	0	0	0	0+0	0
DC b	0	0	0	0	0	0	0	0+0	0
EF b	-1	$1/2Fx$	-Fb/EJ	$-1/2Fx$	Fb/EJ	Fb/EJ	1	$(-1/4+1)Fb^2/EJ$	Xb/EJ
FE b	1	$-1/2Fb+1/2Fx$	Fb/EJ	$-1/2Fb+1/2Fx$	Fb/EJ	Fb/EJ	1	$(-1/4+1)Fb^2/EJ$	Xb/EJ
FC b	-1+x/b	$1/2Fb-1/2qx^2$	0	$-1/2Fb+1/2Fx+1/2Fx^2/b-1/2qx^3/b$	0	0	$1-2x/b+x^2/b^2$	$(-5/24+0)Fb^2/EJ$	1/3Xb/EJ
CF b	x/b	$-Fx+1/2qx^2$	0	$-Fx^2/b+1/2qx^3/b$	0	0	x^2/b^2	$13/24Fb^2/EJ$	5/3Xb/EJ
totali								$-13/40Fb$	

Sviluppi di calcolo iperstatica

$$L_{DE}^{xx} = \int_0^b (x^2/b^2) 1/EJ dx = [1/3 x^3/b^2]_0^b 1/EJ$$

$$= (1/3 b) 1/EJ = 1/3 b/EJ$$

$$L_{ED}^{xx} = \int_0^b (1 - 2x/b + x^2/b^2) 1/EJ dx = [x - x^2/b + 1/3 x^3/b^2]_0^b 1/EJ$$

$$= (b - b + 1/3 b) 1/EJ = 1/3 b/EJ$$

$$L_{EF}^{xx} = \int_0^b (1) 1/EJ dx = [x]_0^b 1/EJ$$

$$= (b) 1/EJ = b/EJ$$

$$L_{FE}^{xx} = \int_0^b (1) 1/EJ dx = [x]_0^b 1/EJ$$

$$= (b) 1/EJ = b/EJ$$

$$L_{FC}^{xx} = \int_0^b (1 - 2x/b + x^2/b^2) 1/EJ dx = [x - x^2/b + 1/3 x^3/b^2]_0^b 1/EJ$$

$$= (b - b + 1/3 b) 1/EJ = 1/3 b/EJ$$

$$L_{CF}^{xx} = \int_0^b (x^2/b^2) 1/EJ dx = [1/3 x^3/b^2]_0^b 1/EJ$$

$$= (1/3 b) 1/EJ = 1/3 b/EJ$$

$$L_{EF}^{xo} = \int_0^b (-1/2 x/b) Fb 1/EJ dx + \int_0^b (1) \theta dx = [-1/4 x^2/b]_0^b Fb 1/EJ + [x]_0^b \theta$$

$$= (-1/4 b) Fb 1/EJ + (b) \theta = 3/4 Fb^2/EJ$$

$$L_{FE}^{xo} = \int_0^b (-1/2 + 1/2 x/b) Fb 1/EJ dx + \int_0^b (-1) \theta dx = [-1/2 x + 1/4 x^2/b]_0^b Fb 1/EJ + [-x]_0^b \theta$$

$$= (-1/2 b + 1/4 b) Fb 1/EJ + (-b) \theta = 3/4 Fb^2/EJ$$

$$L_{FC}^{xo} = \int_0^b (-1/2 + 1/2 x/b + 1/2 x^2/b^2 - 1/2 x^3/b^3) Fb 1/EJ dx$$

$$= [-1/2 x + 1/4 x^2/b + 1/6 x^3/b^2 - 1/8 x^4/b^3]_0^b Fb 1/EJ$$

$$= (-1/2 b + 1/4 b + 1/6 b - 1/8 b) Fb 1/EJ = -5/24 Fb^2/EJ$$

$$L_{CF}^{xo} = \int_0^b (-x^2/b^2 + 1/2 x^3/b^3) Fb 1/EJ dx = [-1/3 x^3/b^2 + 1/8 x^4/b^3]_0^b Fb 1/EJ$$

$$= (-1/3 b + 1/8 b) Fb 1/EJ = -5/24 Fb^2/EJ$$

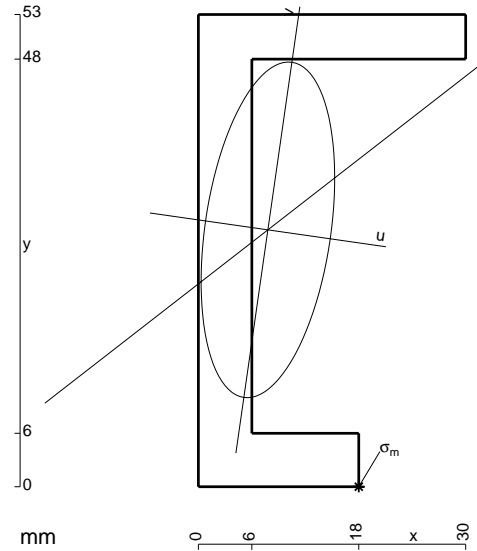

$$A = 510. \text{ mm}^2$$

$$J_x = 181019. \text{ mm}^4$$

$$J_y = 28660. \text{ mm}^4$$

$$J_{xy} = 22270. \text{ mm}^4$$

$$J_u = 184207. \text{ mm}^4$$

$$J_v = 25471. \text{ mm}^4$$

$$\alpha = \text{artg}(2J_{xy}/(J_y - J_x))/2 = -.1422$$

$$c = \cos \alpha = .9899$$

$$s = \sin \alpha = -.1417$$

$$x_g = 7.8 \text{ mm}$$

$$y_g = 28.83 \text{ mm}$$

$$N = -926.3 \text{ N}$$

$$T_y = 1425. \text{ N}$$

$$M_x = 940500. \text{ Nmm}$$

$$x_m = 18. \text{ mm}$$

$$u_m = 14.18 \text{ mm}$$

$$v_m = -27.09 \text{ mm}$$

$$\sigma_m = N/A - Mcv/J_u - Msu/J_v = 209.3 \text{ N/mm}^2$$

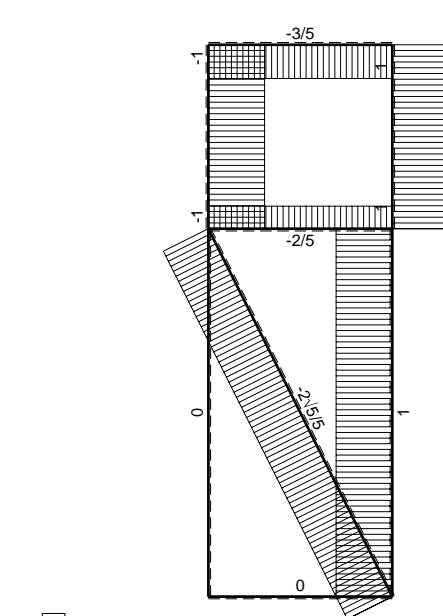
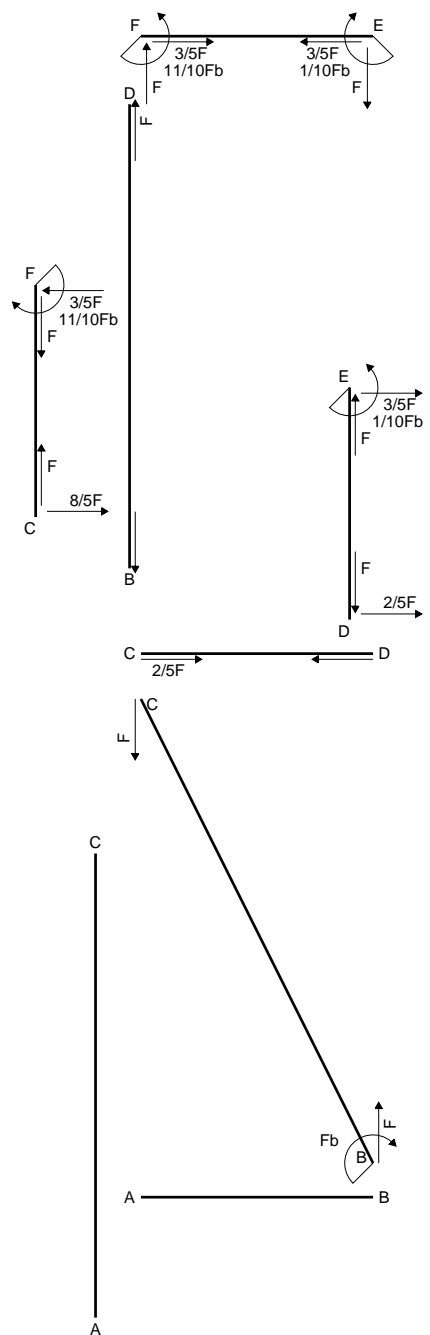

← ⊕ → F

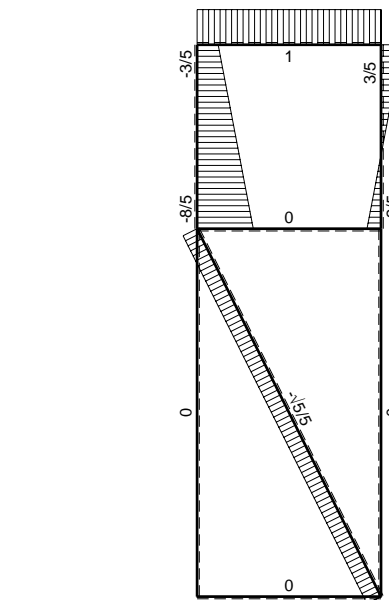

↑ ⊕ ↓ F

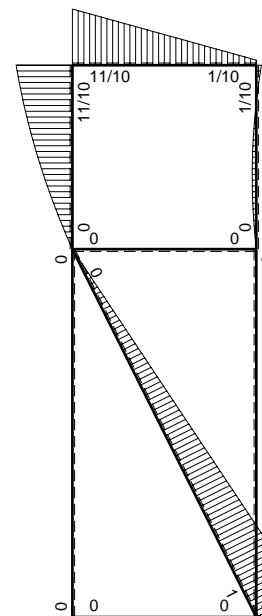

⊕ ⊖ F_b

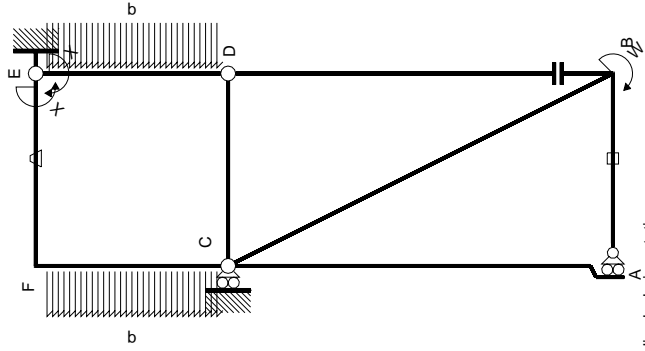

M_0 flessione da carichi assegnati

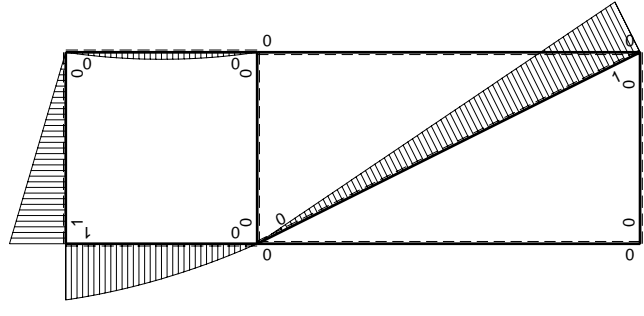

Quadro contributi PLV per iperstatica $X=W_{EF}$

\rightarrow	$M^x(x)$	$M^0(x)$	θ	$M^x M_0$	$M^x \theta$	$M^x M_x$	$\int M^x (M_0/EJ + \theta) dx$	$\int M^x M_x / E J dx$
AB b	0	0	0	0	0	0	0+0	0
BA b	0	0	0	0	0	0	0	0
BC $\sqrt{5}b$	0	$Fb - \sqrt{5}/5 Fx$	0	0	0	0	0	0
CA 2b	0	0	0	0	0	0	0+0	0
DB 2b	0	0	0	0	0	0	0+0	0
BD 2b	0	0	0	0	0	0	0+0	0
DE b	$-x/b$	$-1/2Fx + 1/2qx^2$	0	$1/2Fx^2/b - 1/2qx^3/b$	0	0	x^2/b^2	0
ED b	$1-x/b$	$1/2Fx - 1/2qx^2$	0	$1/2Fx - Fx^2/b + 1/2qx^3/b$	0	0	$1-2x/b+x^2/b^2$	$1/3xb/EJ$
CD b	0	0	0	0	0	0	0+0	0
DC b	0	0	0	0	0	0	0+0	0
EF b	-1	Fx	$-Fb/EJ$	-Fx	Fb/EJ	1	$(-1/2+1)Fb^2/EJ$	Xb/EJ
FE b	1	$-Fb+Fx$	Fb/EJ	$-Fb+Fx$	Fb/EJ	1	$(-1/2+1)Fb^2/EJ$	Xb/EJ
FC b	$-1+x/b$	$Fb - 1/2Fx - 1/2qx^2$	0	$-Fb + 3/2Fx - 1/2qx^3/b$	0	0	$1-2x/b+x^2/b^2$	$1/3xb/EJ$
CF b	x/b	$-3/2Fx + 1/2qx^2$	0	$-3/2Fx^2/b + 1/2qx^3/b$	0	0	x^2/b^2	$1/3xb/EJ$
totali								$5/3xb/EJ$
iperstatica $X=W_{EF}$								$-1/10Fb$

Sviluppi di calcolo iperstatica

M_x flessione da iperstatica $X=1$

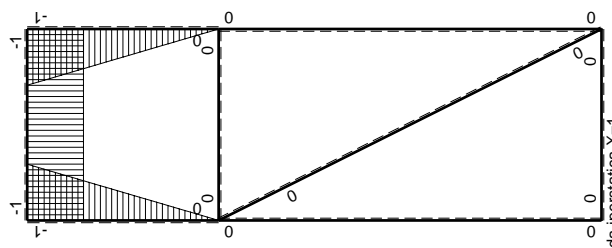

$$L_{DE}^{xx} = \int_0^b (x^2/b^2) 1/EJ dx = [1/3 x^3/b^2]_0^b 1/EJ$$

$$= (1/3 b) 1/EJ = 1/3 b/EJ$$

$$L_{ED}^{xx} = \int_0^b (1 - 2x/b + x^2/b^2) 1/EJ dx = [x - x^2/b + 1/3 x^3/b^2]_0^b 1/EJ$$

$$= (b - b + 1/3 b) 1/EJ = 1/3 b/EJ$$

$$L_{EF}^{xx} = \int_0^b (1) 1/EJ dx = [x]_0^b 1/EJ$$

$$= (b) 1/EJ = b/EJ$$

$$L_{FE}^{xx} = \int_0^b (1) 1/EJ dx = [x]_0^b 1/EJ$$

$$= (b) 1/EJ = b/EJ$$

$$L_{FC}^{xx} = \int_0^b (1 - 2x/b + x^2/b^2) 1/EJ dx = [x - x^2/b + 1/3 x^3/b^2]_0^b 1/EJ$$

$$= (b - b + 1/3 b) 1/EJ = 1/3 b/EJ$$

$$L_{CF}^{xx} = \int_0^b (x^2/b^2) 1/EJ dx = [1/3 x^3/b^2]_0^b 1/EJ$$

$$= (1/3 b) 1/EJ = 1/3 b/EJ$$

$$L_{DE}^{xo} = \int_0^b (1/2 x^2/b^2 - 1/2 x^3/b^3) Fb 1/EJ dx = [1/6 x^3/b^2 - 1/8 x^4/b^3]_0^b Fb 1/EJ$$

$$= (1/6 b - 1/8 b) Fb 1/EJ = 1/24 Fb^2/EJ$$

$$L_{ED}^{xo} = \int_0^b (1/2 x/b - x^2/b^2 + 1/2 x^3/b^3) Fb 1/EJ dx = [1/4 x^2/b - 1/3 x^3/b^2 + 1/8 x^4/b^3]_0^b Fb 1/EJ$$

$$= (1/4 b - 1/3 b + 1/8 b) Fb 1/EJ = 1/24 Fb^2/EJ$$

$$L_{EF}^{xo} = \int_0^b (-x/b) Fb 1/EJ dx + \int_0^b (1) \theta dx = [-1/2 x^2/b]_0^b Fb 1/EJ + [x]_0^b \theta$$

$$= (-1/2 b) Fb 1/EJ + (b) \theta = 1/2 Fb^2/EJ$$

$$L_{FE}^{xo} = \int_0^b (-1 + x/b) Fb 1/EJ dx + \int_0^b (-1) \theta dx = [-x + 1/2 x^2/b]_0^b Fb 1/EJ + [-x]_0^b \theta$$

$$= (-b + 1/2 b) Fb 1/EJ + (-b) \theta = 1/2 Fb^2/EJ$$

$$L_{FC}^{xo} = \int_0^b (-1 + 3/2 x/b - 1/2 x^3/b^3) Fb 1/EJ dx = [-x + 3/4 x^2/b - 1/8 x^4/b^3]_0^b Fb 1/EJ$$

$$= (-b + 3/4 b - 1/8 b) Fb 1/EJ = -3/8 Fb^2/EJ$$

$$L_{CF}^{xo} = \int_0^b (-3/2 x^2/b^2 + 1/2 x^3/b^3) Fb 1/EJ dx = [-1/2 x^3/b^2 + 1/8 x^4/b^3]_0^b Fb 1/EJ$$

$$= (-1/2 b + 1/8 b) Fb 1/EJ = -3/8 Fb^2/EJ$$

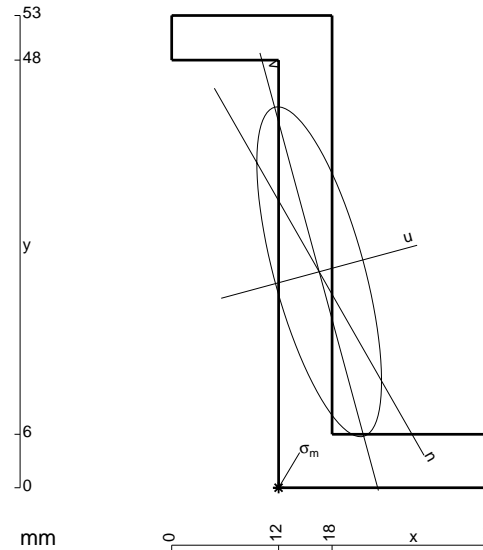

- A = 486. mm²
- J_x = 166610. mm⁴
- J_y = 23826. mm⁴
- J_{xy} = -41708. mm⁴
- J_u = 177900. mm⁴
- J_v = 12536. mm⁴
- α = arctg(2J_{xy}/(J_y-J_x))/2 = .2644
- c = cosα = .9653
- s = sinα = .2613
- x_g = 16.56 mm
- y_g = 24.24 mm
- N = -798. N
- T_y = 1330. N
- M_x = 643720. Nmm
- x_m = 12. mm
- u_m = -10.73 mm
- v_m = -22.21 mm
- σ_m = N/A - Mcv/J_u - Msu/J_v = 219.9 N/mm²

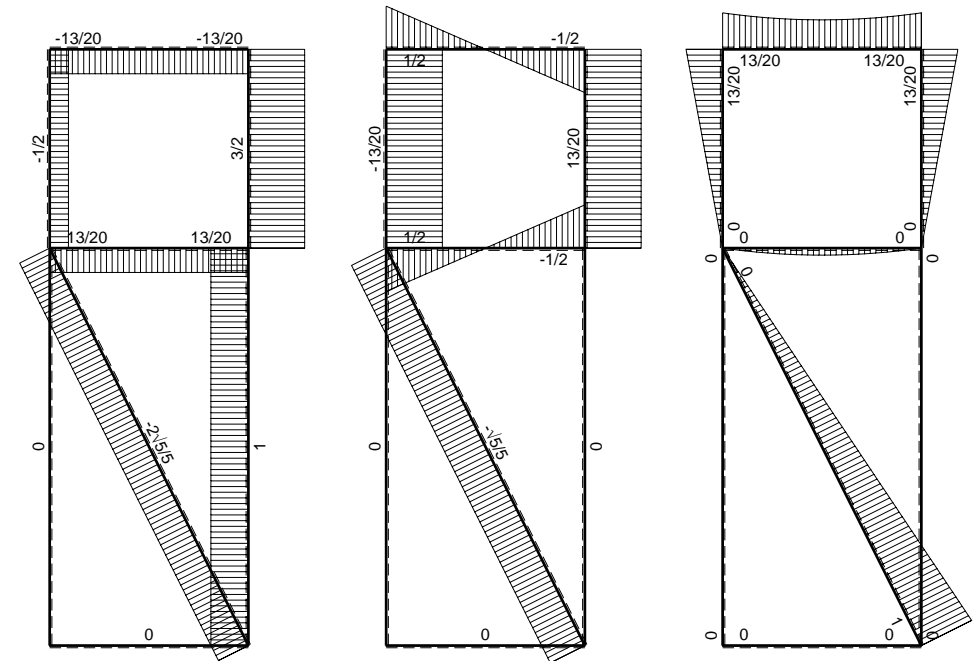
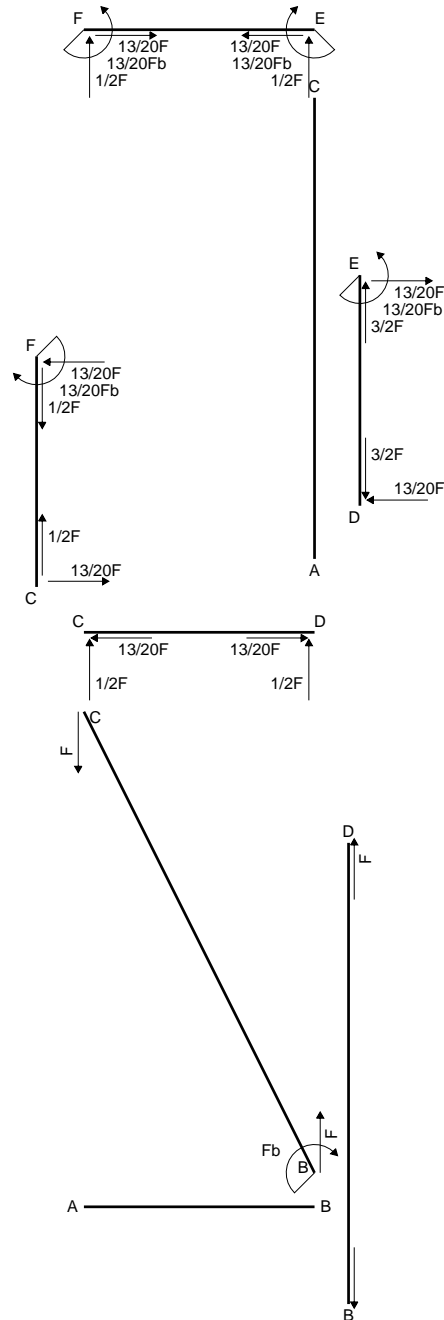

← ⊕ → F

↑ ⊕ ↓ F

⊕ ⊖ F_b

$$L_{DE}^{xx} = \int_0^b (x^2/b^2) 1/EJ dx = [1/3 x^3/b^2]_0^b 1/EJ$$

$$= (1/3 b) 1/EJ = 1/3 b/EJ$$

$$L_{ED}^{xx} = \int_0^b (1 - 2x/b + x^2/b^2) 1/EJ dx = [x - x^2/b + 1/3 x^3/b^2]_0^b 1/EJ$$

$$= (b - b + 1/3 b) 1/EJ = 1/3 b/EJ$$

$$L_{EF}^{xx} = \int_0^b (1) 1/EJ dx = [x]_0^b 1/EJ$$

$$= (b) 1/EJ = b/EJ$$

$$L_{FE}^{xx} = \int_0^b (1) 1/EJ dx = [x]_0^b 1/EJ$$

$$= (b) 1/EJ = b/EJ$$

$$L_{FC}^{xx} = \int_0^b (1 - 2x/b + x^2/b^2) 1/EJ dx = [x - x^2/b + 1/3 x^3/b^2]_0^b 1/EJ$$

$$= (b - b + 1/3 b) 1/EJ = 1/3 b/EJ$$

$$L_{CF}^{xx} = \int_0^b (x^2/b^2) 1/EJ dx = [1/3 x^3/b^2]_0^b 1/EJ$$

$$= (1/3 b) 1/EJ = 1/3 b/EJ$$

$$L_{EF}^{xo} = \int_0^b (1/2 x/b - 1/2 x^2/b^2) Fb 1/EJ dx + \int_0^b (1) \theta dx = [1/4 x^2/b - 1/6 x^3/b^2]_0^b Fb 1/EJ + [x]_0^b \theta$$

$$= (1/4 b - 1/6 b) Fb 1/EJ + (b) \theta = 13/12 Fb^2/EJ$$

$$L_{FE}^{xo} = \int_0^b (1/2 x/b - 1/2 x^2/b^2) Fb 1/EJ dx + \int_0^b (-1) \theta dx = [1/4 x^2/b - 1/6 x^3/b^2]_0^b Fb 1/EJ + [-x]_0^b \theta$$

$$= (1/4 b - 1/6 b) Fb 1/EJ + (-b) \theta = 13/12 Fb^2/EJ$$

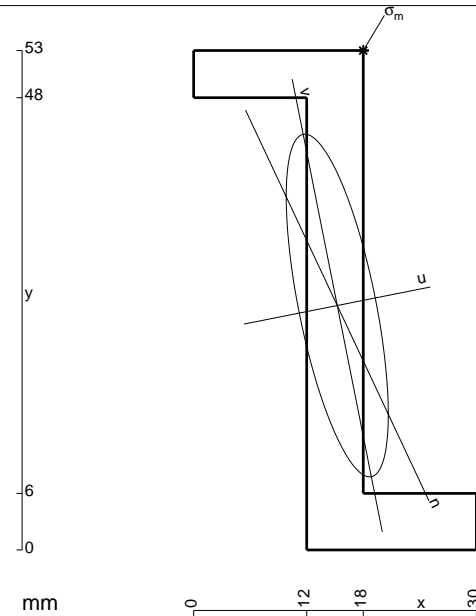

$$A = 450. \text{ mm}^2$$

$$J_x = 148960. \text{ mm}^4$$

$$J_y = 13204. \text{ mm}^4$$

$$J_{xy} = -28128. \text{ mm}^4$$

$$J_u = 154557. \text{ mm}^4$$

$$J_v = 7607. \text{ mm}^4$$

$$\alpha = \text{artg}(2J_{xy}/(J_y - J_x))/2 = .1964$$

$$c = \cos \alpha = .9808$$

$$s = \sin \alpha = .1952$$

$$x_g = 15.24 \text{ mm}$$

$$y_g = 25.94 \text{ mm}$$

$$N = -1145. \text{ N}$$

$$T_y = -572.4 \text{ N}$$

$$M_x = 614400. \text{ Nmm}$$

$$x_m = 18. \text{ mm}$$

$$y_m = 53. \text{ mm}$$

$$u_m = 7.988 \text{ mm}$$

$$v_m = 26. \text{ mm}$$

$$\sigma_m = N/A - Mcv/J_u - Msu/J_v = -229.8 \text{ N/mm}^2$$

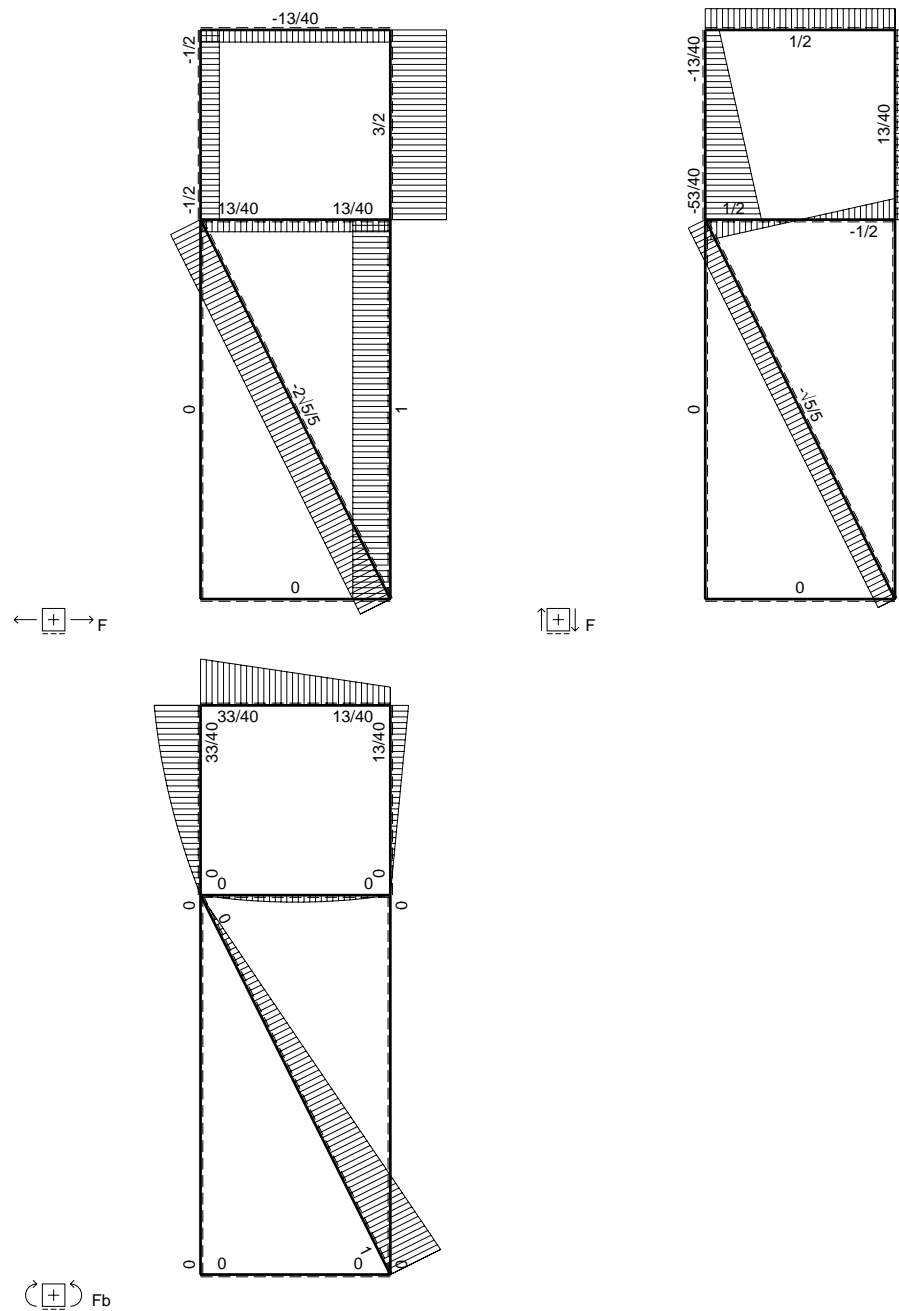
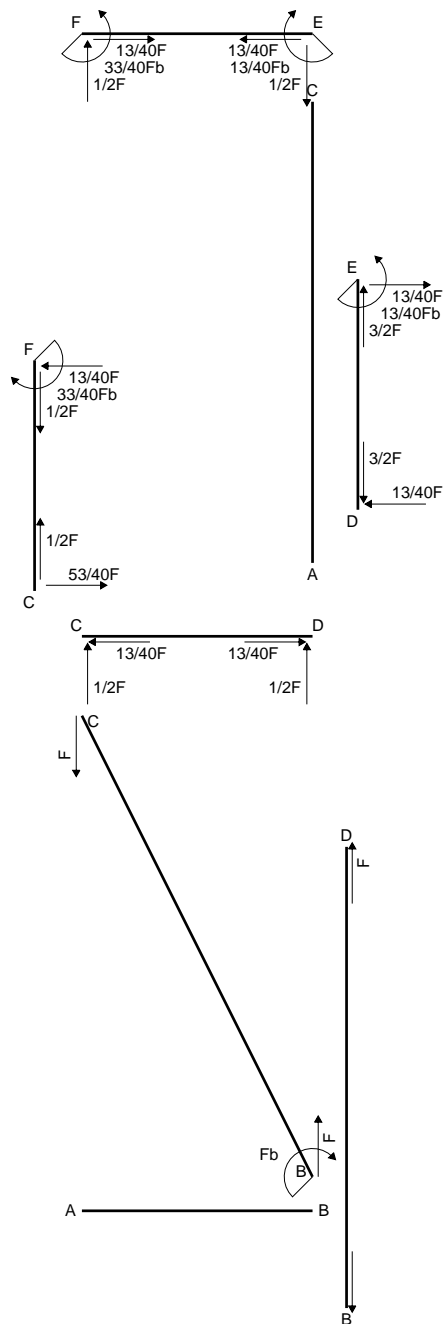

$$L_{DE}^{xx} = \int_0^b (x^2/b^2) 1/EJ dx = [1/3 x^3/b^2]_0^b 1/EJ$$

$$= (1/3 b) 1/EJ = 1/3 b/EJ$$

$$L_{ED}^{xx} = \int_0^b (1 - 2x/b + x^2/b^2) 1/EJ dx = [x - x^2/b + 1/3 x^3/b^2]_0^b 1/EJ$$

$$= (b - b + 1/3 b) 1/EJ = 1/3 b/EJ$$

$$L_{EF}^{xx} = \int_0^b (1) 1/EJ dx = [x]_0^b 1/EJ$$

$$= (b) 1/EJ = b/EJ$$

$$L_{FE}^{xx} = \int_0^b (1) 1/EJ dx = [x]_0^b 1/EJ$$

$$= (b) 1/EJ = b/EJ$$

$$L_{FC}^{xx} = \int_0^b (1 - 2x/b + x^2/b^2) 1/EJ dx = [x - x^2/b + 1/3 x^3/b^2]_0^b 1/EJ$$

$$= (b - b + 1/3 b) 1/EJ = 1/3 b/EJ$$

$$L_{CF}^{xx} = \int_0^b (x^2/b^2) 1/EJ dx = [1/3 x^3/b^2]_0^b 1/EJ$$

$$= (1/3 b) 1/EJ = 1/3 b/EJ$$

$$L_{EF}^{xo} = \int_0^b (-1/2 x/b) Fb 1/EJ dx + \int_0^b (1) \theta dx = [-1/4 x^2/b]_0^b Fb 1/EJ + [x]_0^b \theta$$

$$= (-1/4 b) Fb 1/EJ + (b) \theta = 3/4 Fb^2/EJ$$

$$L_{FE}^{xo} = \int_0^b (-1/2 + 1/2 x/b) Fb 1/EJ dx + \int_0^b (-1) \theta dx = [-1/2 x + 1/4 x^2/b]_0^b Fb 1/EJ + [-x]_0^b \theta$$

$$= (-1/2 b + 1/4 b) Fb 1/EJ + (-b) \theta = 3/4 Fb^2/EJ$$

$$L_{FC}^{xo} = \int_0^b (-1/2 + 1/2 x/b + 1/2 x^2/b^2 - 1/2 x^3/b^3) Fb 1/EJ dx$$

$$= [-1/2 x + 1/4 x^2/b + 1/6 x^3/b^2 - 1/8 x^4/b^3]_0^b Fb 1/EJ$$

$$= (-1/2 b + 1/4 b + 1/6 b - 1/8 b) Fb 1/EJ = -5/24 Fb^2/EJ$$

$$L_{CF}^{xo} = \int_0^b (-x^2/b^2 + 1/2 x^3/b^3) Fb 1/EJ dx = [-1/3 x^3/b^2 + 1/8 x^4/b^3]_0^b Fb 1/EJ$$

$$= (-1/3 b + 1/8 b) Fb 1/EJ = -5/24 Fb^2/EJ$$

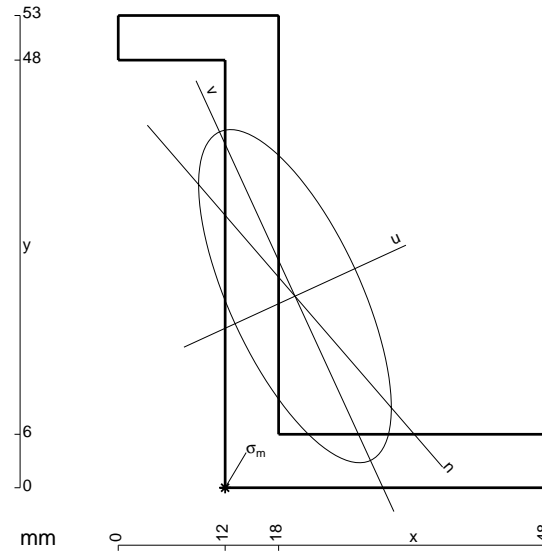

$A = 558. \text{ mm}^2$
 $J_x = 195119. \text{ mm}^4$
 $J_y = 65290. \text{ mm}^4$
 $J_{xy} = -75600. \text{ mm}^4$
 $J_u = 229850. \text{ mm}^4$
 $J_v = 30558. \text{ mm}^4$
 $\alpha = \text{artg}(2J_{xy}/(J_y - J_x))/2 = .4306$
 $c = \cos \alpha = .9087$
 $s = \sin \alpha = .4175$
 $x_g = 19.84 \text{ mm}$
 $y_g = 21.5 \text{ mm}$
 $N = -1494. \text{ N}$
 $T_y = -746.8 \text{ N}$
 $M_x = 851700. \text{ Nmm}$
 $x_m = 12. \text{ mm}$
 $u_m = -16.1 \text{ mm}$
 $v_m = -16.26 \text{ mm}$
 $\sigma_m = N/A - Mcv/J_u - Msu/J_v = 239.4 \text{ N/mm}^2$

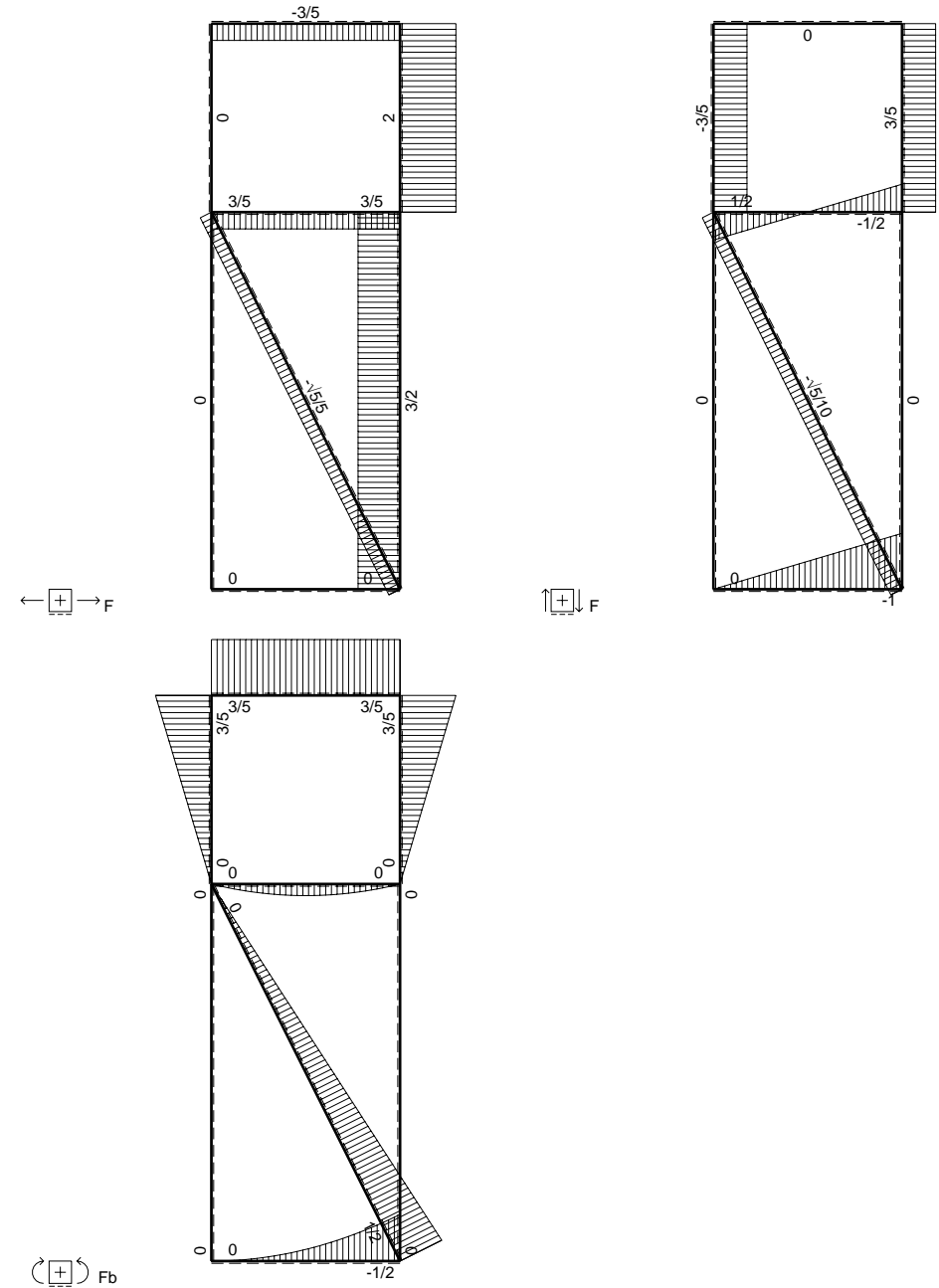
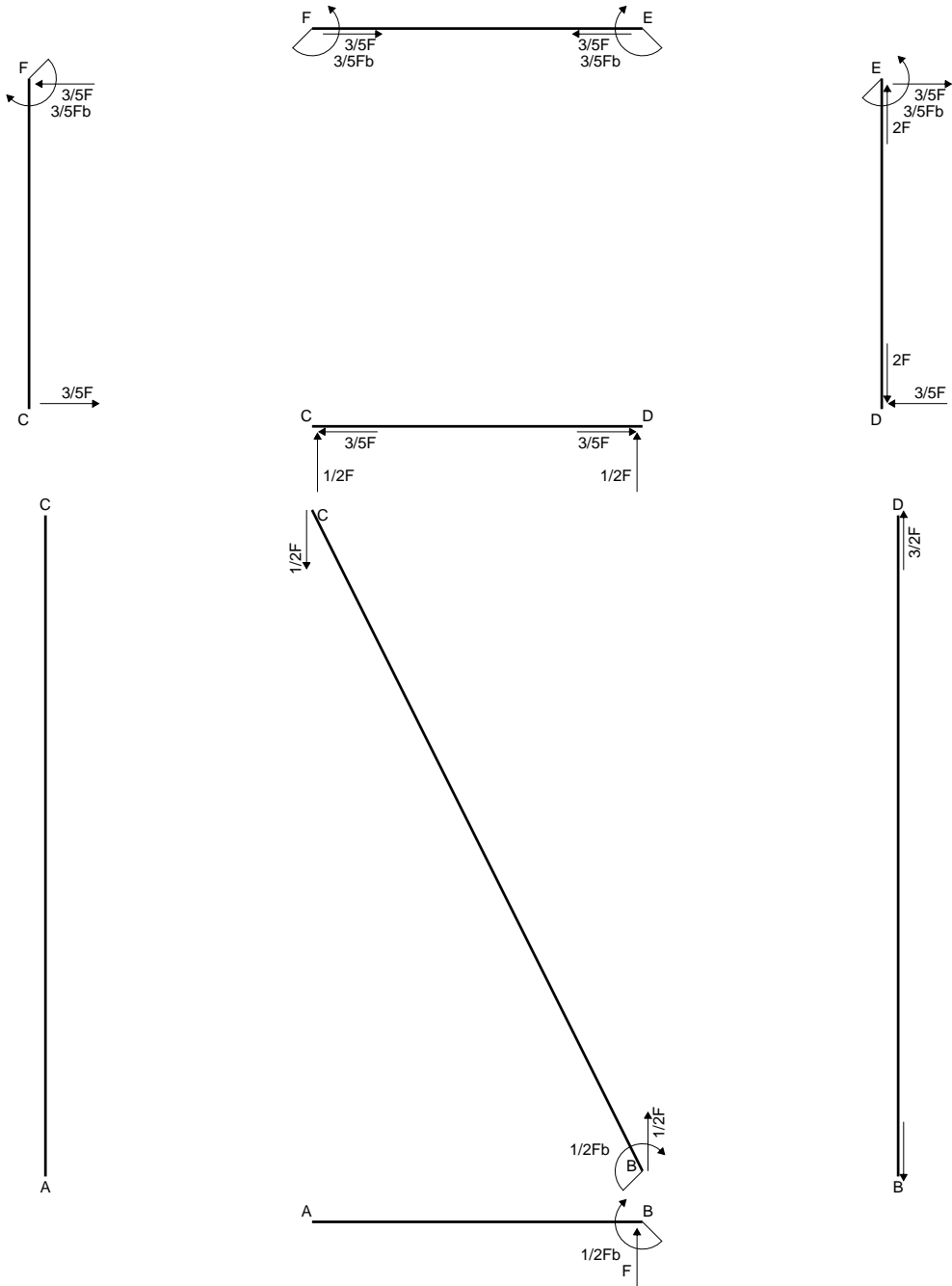

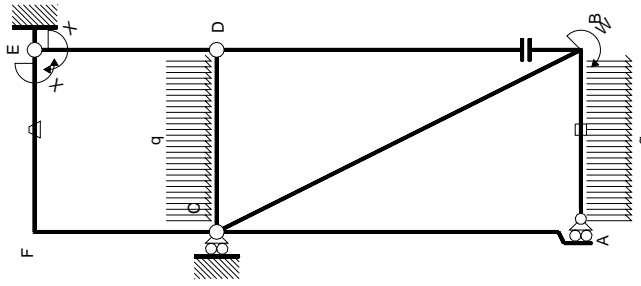

Schema di calcolo iperstatico

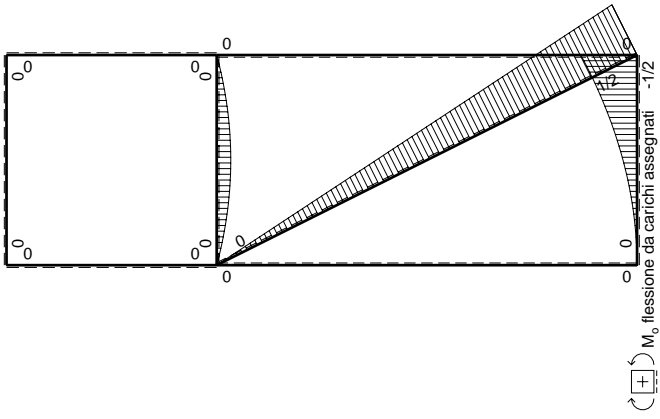

M_0 flessione da carichi assegnati

Quadro contributi PLV per iperstatica $X=W_{EF}$

\rightarrow	$M_x(x)$	$M_0(x)$	θ	$M_x M_0$	$M_x \theta$	$M_x M_x$	$\int M_x(M_0/EJ+\theta)dx$	$\int X M_x M_x/EJ dx$
AB b	0	$-1/2qx^2$	0	0	0	0	0+0	0
BA b	0	$1/2Fb-Fx+1/2qx^2$	0	0	0	0	0+0	0
BC $\sqrt{5}b$	0	$1/2Fb-\sqrt{5}/10Fx$	0	0	0	0	0	0
AC 2b	0	0	0	0	0	0	0+0	0
CA 2b	0	0	0	0	0	0	0+0	0
DB 2b	0	0	0	0	0	0	0+0	0
BD 2b	0	0	0	0	0	0	0+0	0
DE b	$-x/b$	0	0	0	0	x^2/b^2	0+0	$1/3Xb/EJ$
ED b	$1-x/b$	0	0	0	0	$1-2x/b+x^2/b^2$	0+0	0
CD b	0	$1/2Fx-1/2qx^2$	0	0	0	0	0+0	0
DC b	0	$-1/2Fx+1/2qx^2$	0	0	0	0	0+0	0
EF b	-1	0	$-Fb/EJ$	0	Fb/EJ	1	$(0+1)Fb^2/EJ$	Xb/EJ
FE b	1	0	Fb/EJ	0	Fb/EJ	1		
FC b	$-1+x/b$	0	0	0	0	$1-2x/b+x^2/b^2$	0+0	$1/3Xb/EJ$
CF b	x/b	0	0	0	0	x^2/b^2	Fb^2/EJ	$5/3Xb/EJ$
	totali							
	iperstatica $X=W_{EF}$							

Sviluppi di calcolo iperstatica

M_x flessione da iperstatica $X=1$



$$L_{DE}^{xx} = \int_0^b (x^2/b^2) 1/EJ dx = [1/3 x^3/b^2]_0^b 1/EJ$$

$$= (1/3 b) 1/EJ = 1/3 b/EJ$$

$$L_{ED}^{xx} = \int_0^b (1 - 2x/b + x^2/b^2) 1/EJ dx = [x - x^2/b + 1/3 x^3/b^2]_0^b 1/EJ$$

$$= (b - b + 1/3 b) 1/EJ = 1/3 b/EJ$$

$$L_{EF}^{xx} = \int_0^b (1) 1/EJ dx = [x]_0^b 1/EJ$$

$$= (b) 1/EJ = b/EJ$$

$$L_{FE}^{xx} = \int_0^b (1) 1/EJ dx = [x]_0^b 1/EJ$$

$$= (b) 1/EJ = b/EJ$$

$$L_{FC}^{xx} = \int_0^b (1 - 2x/b + x^2/b^2) 1/EJ dx = [x - x^2/b + 1/3 x^3/b^2]_0^b 1/EJ$$

$$= (b - b + 1/3 b) 1/EJ = 1/3 b/EJ$$

$$L_{CF}^{xx} = \int_0^b (x^2/b^2) 1/EJ dx = [1/3 x^3/b^2]_0^b 1/EJ$$

$$= (1/3 b) 1/EJ = 1/3 b/EJ$$

$$L_{EF}^{xo} = \int_0^b (1) \theta dx = [x]_0^b \theta$$

$$= (b) \theta = Fb^2/EJ$$

$$L_{FE}^{xo} = \int_0^b (-1) \theta dx = [-x]_0^b \theta$$

$$= (-b) \theta = Fb^2/EJ$$

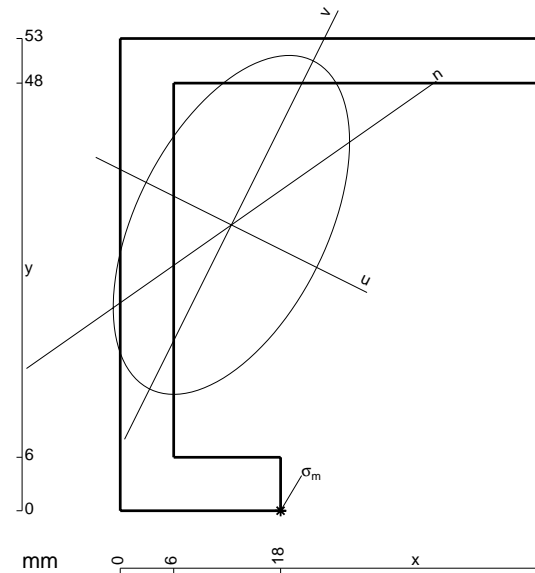

$A = 600. \text{ mm}^2$
 $J_x = 217132. \text{ mm}^4$
 $J_y = 105558. \text{ mm}^4$
 $J_{xy} = 73993. \text{ mm}^4$
 $J_u = 254012. \text{ mm}^4$
 $J_v = 68678. \text{ mm}^4$
 $\alpha = \text{artg}(2J_{xy}/(J_y - J_x))/2 = -.4624$
 $c = \cos \alpha = .8950$
 $s = \sin \alpha = -.4461$
 $x_g = 12.48 \text{ mm}$
 $y_g = 32.08 \text{ mm}$
 $N = 5320. \text{ N}$
 $T_y = 1596. \text{ N}$
 $M_x = 877800. \text{ Nmm}$
 $x_m = 18. \text{ mm}$
 $u_m = 19.25 \text{ mm}$
 $v_m = -26.25 \text{ mm}$
 $\sigma_m = N/A - Mcv/J_u - Msu/J_v = 199.8 \text{ N/mm}^2$

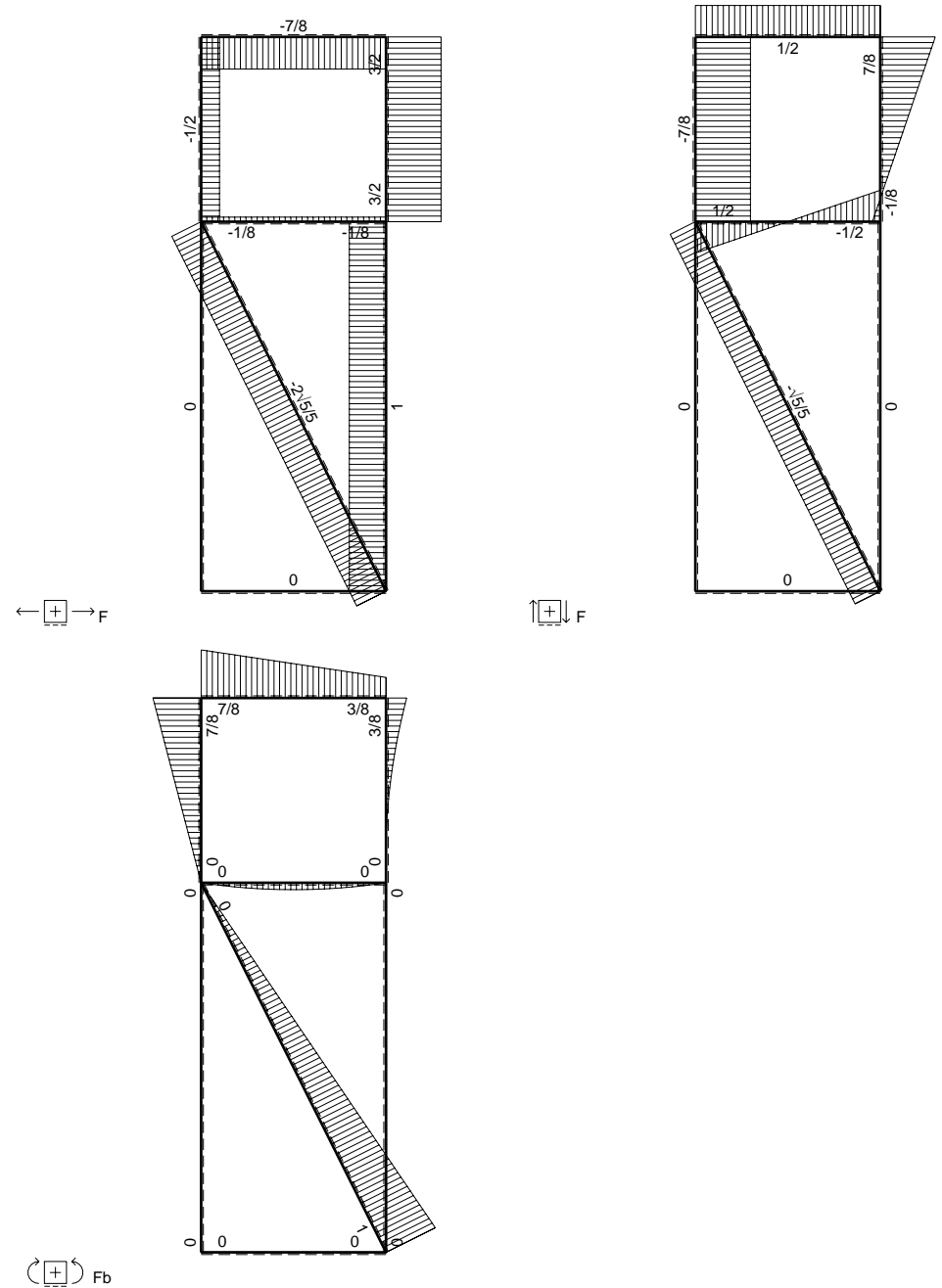
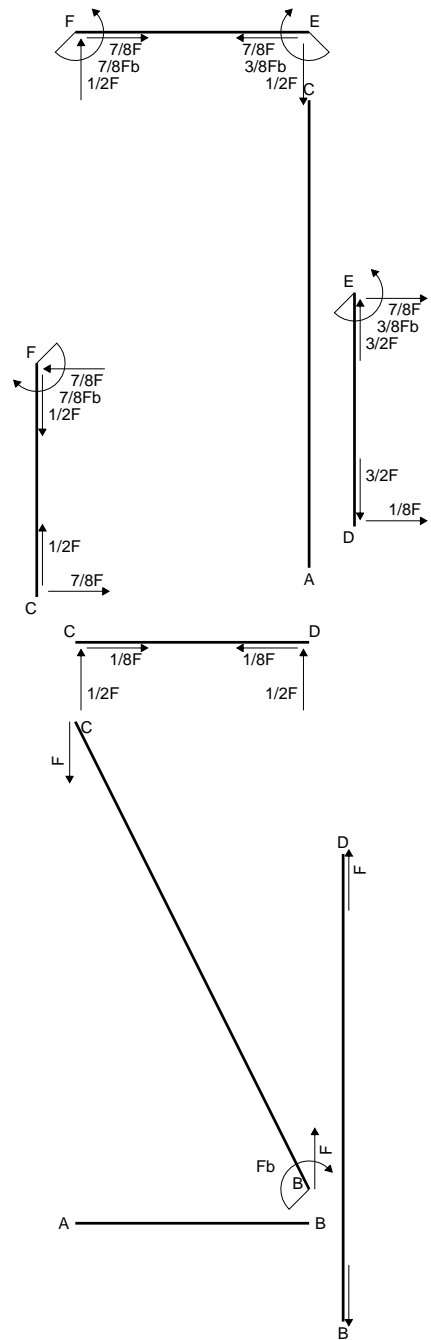

$$L_{DE}^{xx} = \int_0^b (x^2/b^2) 1/EJ dx = [1/3 x^3/b^2]_0^b 1/EJ$$

$$= (1/3 b) 1/EJ = 1/3 b/EJ$$

$$L_{ED}^{xx} = \int_0^b (1 - 2x/b + x^2/b^2) 1/EJ dx = [x - x^2/b + 1/3 x^3/b^2]_0^b 1/EJ$$

$$= (b - b + 1/3 b) 1/EJ = 1/3 b/EJ$$

$$L_{EF}^{xx} = \int_0^b (1) 1/EJ dx = [x]_0^b 1/EJ$$

$$= (b) 1/EJ = b/EJ$$

$$L_{FE}^{xx} = \int_0^b (1) 1/EJ dx = [x]_0^b 1/EJ$$

$$= (b) 1/EJ = b/EJ$$

$$L_{FC}^{xx} = \int_0^b (1 - 2x/b + x^2/b^2) 1/EJ dx = [x - x^2/b + 1/3 x^3/b^2]_0^b 1/EJ$$

$$= (b - b + 1/3 b) 1/EJ = 1/3 b/EJ$$

$$L_{CF}^{xx} = \int_0^b (x^2/b^2) 1/EJ dx = [1/3 x^3/b^2]_0^b 1/EJ$$

$$= (1/3 b) 1/EJ = 1/3 b/EJ$$

$$L_{DE}^{xo} = \int_0^b (1/2 x^2/b^2 - 1/2 x^3/b^3) Fb 1/EJ dx = [1/6 x^3/b^2 - 1/8 x^4/b^3]_0^b Fb 1/EJ$$

$$= (1/6 b - 1/8 b) Fb 1/EJ = 1/24 Fb^2/EJ$$

$$L_{ED}^{xo} = \int_0^b (1/2 x/b - x^2/b^2 + 1/2 x^3/b^3) Fb 1/EJ dx = [1/4 x^2/b - 1/3 x^3/b^2 + 1/8 x^4/b^3]_0^b Fb 1/EJ$$

$$= (1/4 b - 1/3 b + 1/8 b) Fb 1/EJ = 1/24 Fb^2/EJ$$

$$L_{EF}^{xo} = \int_0^b (-1/2 x/b) Fb 1/EJ dx + \int_0^b (1) \theta dx = [-1/4 x^2/b]_0^b Fb 1/EJ + [x]_0^b \theta$$

$$= (-1/4 b) Fb 1/EJ + (b) \theta = 3/4 Fb^2/EJ$$

$$L_{FE}^{xo} = \int_0^b (-1/2 + 1/2 x/b) Fb 1/EJ dx + \int_0^b (-1) \theta dx = [-1/2 x + 1/4 x^2/b]_0^b Fb 1/EJ + [-x]_0^b \theta$$

$$= (-1/2 b + 1/4 b) Fb 1/EJ + (-b) \theta = 3/4 Fb^2/EJ$$

$$L_{FC}^{xo} = \int_0^b (-1/2 + x/b - 1/2 x^2/b^2) Fb 1/EJ dx = [-1/2 x + 1/2 x^2/b - 1/6 x^3/b^2]_0^b Fb 1/EJ$$

$$= (-1/2 b + 1/2 b - 1/6 b) Fb 1/EJ = -1/6 Fb^2/EJ$$

$$L_{CF}^{xo} = \int_0^b (-1/2 x^2/b^2) Fb 1/EJ dx = [-1/6 x^3/b^2]_0^b Fb 1/EJ$$

$$= (-1/6 b) Fb 1/EJ = -1/6 Fb^2/EJ$$

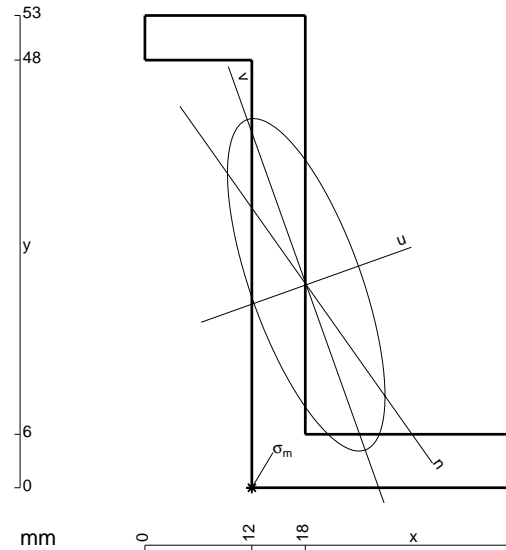

$A = 522. \text{ mm}^2$
 $J_x = 181840. \text{ mm}^4$
 $J_y = 40818. \text{ mm}^4$
 $J_{xy} = -57687. \text{ mm}^4$
 $J_u = 202431. \text{ mm}^4$
 $J_v = 20227. \text{ mm}^4$
 $\alpha = \text{artg}(2J_{xy}/(J_y - J_x))/2 = .3428$
 $c = \cos \alpha = .9418$
 $s = \sin \alpha = .3362$
 $x_g = 18.1 \text{ mm}$
 $y_g = 22.78 \text{ mm}$
 $N = -1020. \text{ N}$
 $T_y = -509.8 \text{ N}$
 $M_x = 672600. \text{ Nmm}$
 $x_m = 12. \text{ mm}$
 $u_m = -13.4 \text{ mm}$
 $v_m = -19.4 \text{ mm}$
 $\sigma_m = N/A - Mcv/J_u - Msu/J_v = 208.6 \text{ N/mm}^2$

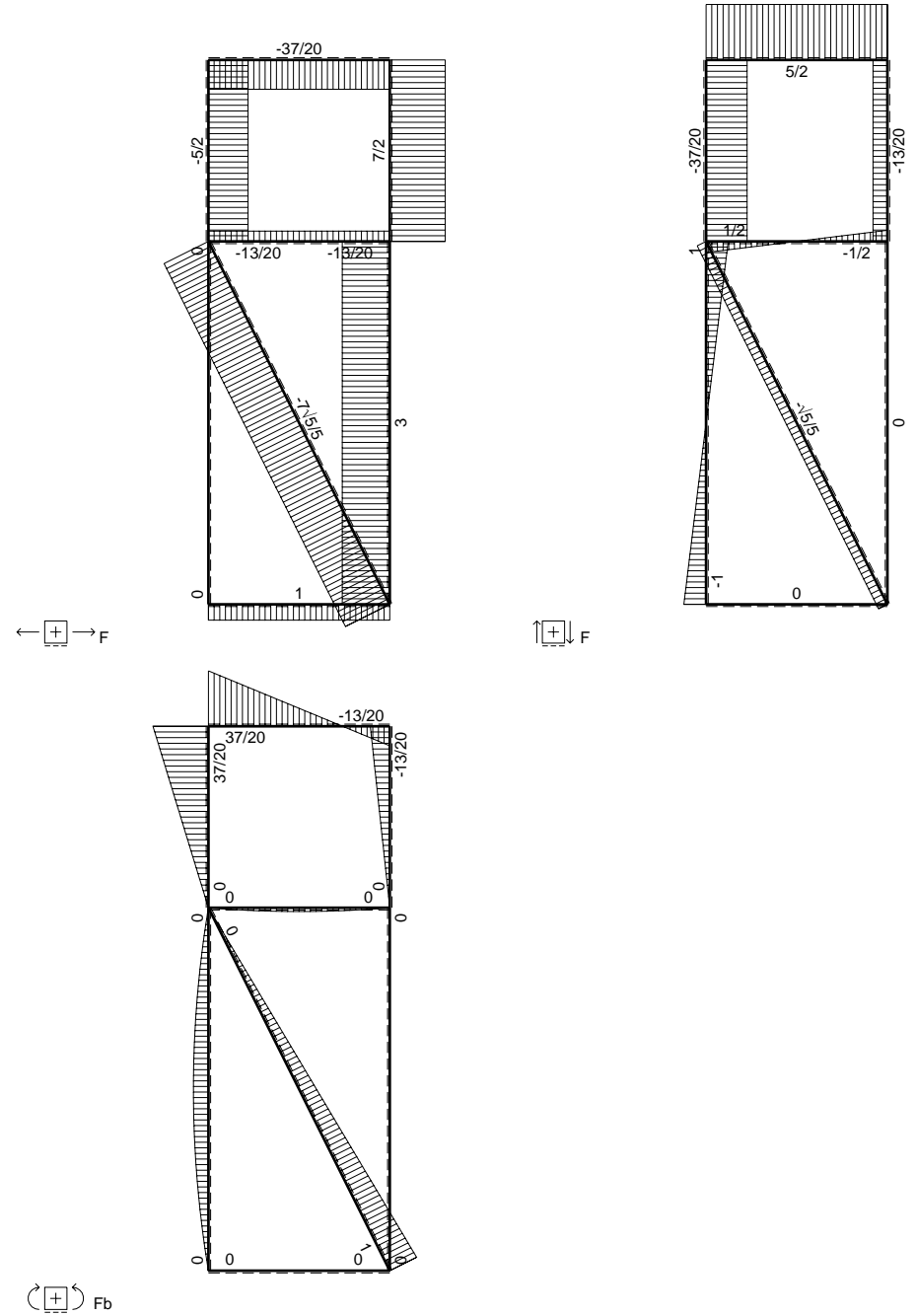
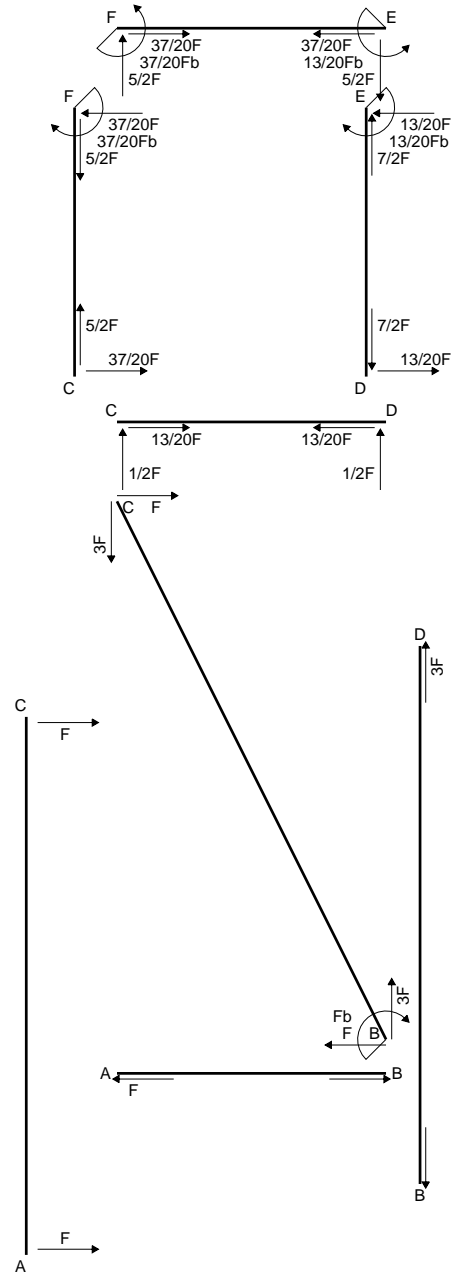

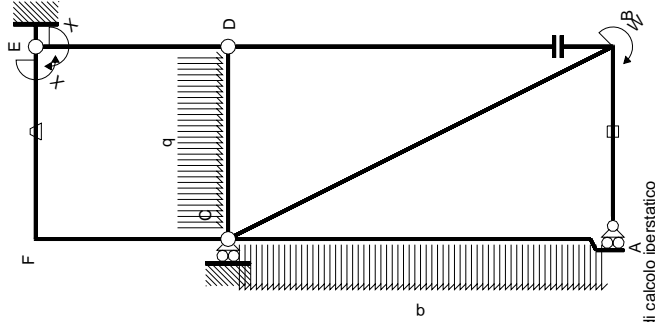

M_0 flessione da carichi assegnati

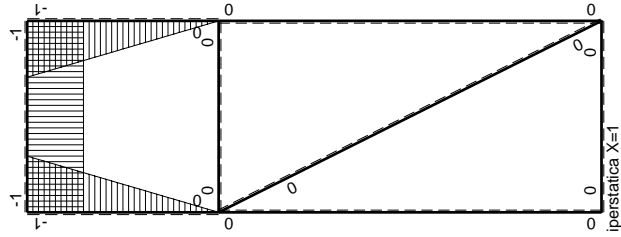

Quadro contribuiti PLV per iperstatica $X=W_{EP}$

	$M^x(x)$	$M^0(x)$	θ	$M^x M_0$	$M^x \theta$	$M^x M_x$	$\int M^x(M_0/EJ+\theta)dx$	$\int M^x M_x/EJdx$
AB b	0	0	0	0	0	0	0	0
BA b	0	0	0	0	0	0	0	0
BC $\sqrt{5}b$	0	$Fb-\sqrt{5/5}Fx$	0	0	0	0	0	0
AC 2b	0	$-Fx+1/2qx^2$	0	0	0	0	0	0
CA 2b	0	$Fx-1/2qx^2$	0	0	0	0	0	0
DB 2b	0	0	0	0	0	0	0	0
BD 2b	0	0	0	0	0	0	0	0
DE b	$-x/b$	0	0	0	0	0	x^2/b^2	$1/3Xb/EJ$
ED b	$1-x/b$	0	0	0	0	0	$1-2x/b+x^2/b^2$	$1/3Xb/EJ$
CD b	0	$1/2Fx-1/2qx^2$	0	0	0	0	0	0
DC b	0	$-1/2Fx+1/2qx^2$	0	0	0	0	0	0
EF b	-1	$5/2Fx$	$-Fb/EJ$	$-5/2Fx$	Fb/EJ	1	$(-5/4+1)Fb^2/EJ$	Xb/EJ
FE b	1	$-5/2Fb+5/2Fx$	Fb/EJ	$-5/2Fb+5/2Fx$	Fb/EJ	1	$(-5/4+1)Fb^2/EJ$	Xb/EJ
FC b	$-1+x/b$	$5/2Fb-5/2Fx$	0	$-5/2Fb+5Fx-5/2Fx^2/b$	0	0	$1-2x/b+x^2/b^2$	$(-5/6+0)Fb^2/EJ$
CF b	x/b	$-5/2Fx$	0	$-5/2Fx^2/b$	0	0	x^2/b^2	$1/3Xb/EJ$
totali								
iperstatica $X=W_{EP}$								$13/20Fb$

Sviluppi di calcolo iperstatica

$$L_{DE}^{xx} = \int_0^b (x^2/b^2) 1/EJ dx = [1/3 x^3/b^2]_0^b 1/EJ$$

$$= (1/3 b) 1/EJ = 1/3 b/EJ$$

$$L_{ED}^{xx} = \int_0^b (1 - 2x/b + x^2/b^2) 1/EJ dx = [x - x^2/b + 1/3 x^3/b^2]_0^b 1/EJ$$

$$= (b - b + 1/3 b) 1/EJ = 1/3 b/EJ$$

$$L_{EF}^{xx} = \int_0^b (1) 1/EJ dx = [x]_0^b 1/EJ$$

$$= (b) 1/EJ = b/EJ$$

$$L_{FE}^{xx} = \int_0^b (1) 1/EJ dx = [x]_0^b 1/EJ$$

$$= (b) 1/EJ = b/EJ$$

$$L_{FC}^{xx} = \int_0^b (1 - 2x/b + x^2/b^2) 1/EJ dx = [x - x^2/b + 1/3 x^3/b^2]_0^b 1/EJ$$

$$= (b - b + 1/3 b) 1/EJ = 1/3 b/EJ$$

$$L_{CF}^{xx} = \int_0^b (x^2/b^2) 1/EJ dx = [1/3 x^3/b^2]_0^b 1/EJ$$

$$= (1/3 b) 1/EJ = 1/3 b/EJ$$

$$L_{EF}^{xo} = \int_0^b (-5/2 x/b) Fb 1/EJ dx + \int_0^b (1) \theta dx = [-5/4 x^2/b]_0^b Fb 1/EJ + [x]_0^b \theta$$

$$= (-5/4 b) Fb 1/EJ + (b) \theta = -1/4 Fb^2/EJ$$

$$L_{FE}^{xo} = \int_0^b (-5/2 + 5/2 x/b) Fb 1/EJ dx + \int_0^b (-1) \theta dx = [-5/2 x + 5/4 x^2/b]_0^b Fb 1/EJ + [-x]_0^b \theta$$

$$= (-5/2 b + 5/4 b) Fb 1/EJ + (-b) \theta = -1/4 Fb^2/EJ$$

$$L_{FC}^{xo} = \int_0^b (-5/2 + 5x/b - 5/2 x^2/b^2) Fb 1/EJ dx = [-5/2 x + 5/2 x^2/b - 5/6 x^3/b^2]_0^b Fb 1/EJ$$

$$= (-5/2 b + 5/2 b - 5/6 b) Fb 1/EJ = -5/6 Fb^2/EJ$$

$$L_{CF}^{xo} = \int_0^b (-5/2 x^2/b^2) Fb 1/EJ dx = [-5/6 x^3/b^2]_0^b Fb 1/EJ$$

$$= (-5/6 b) Fb 1/EJ = -5/6 Fb^2/EJ$$

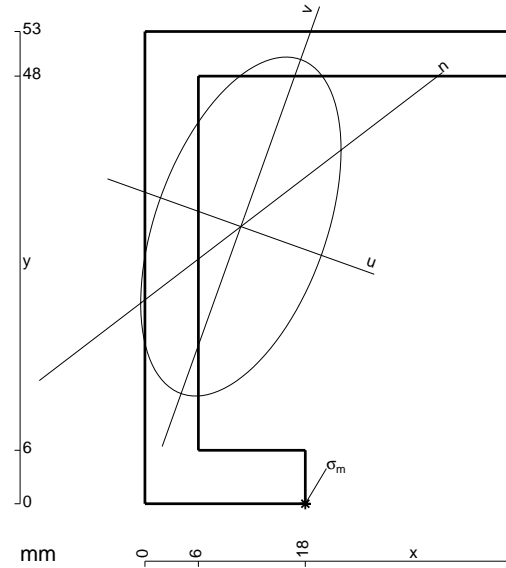

$$A = 570. \text{ mm}^2$$

$$J_x = 206355. \text{ mm}^4$$

$$J_y = 72071. \text{ mm}^4$$

$$J_{xy} = 55077. \text{ mm}^4$$

$$J_u = 226055. \text{ mm}^4$$

$$J_v = 52372. \text{ mm}^4$$

$$\alpha = \text{artg}(2J_{xy}/(J_y - J_x))/2 = -.3435$$

$$c = \cos \alpha = .9416$$

$$s = \sin \alpha = -.3368$$

$$x_g = 10.77 \text{ mm}$$

$$y_g = 31.11 \text{ mm}$$

$$N = -1610. \text{ N}$$

$$T_y = 2175. \text{ N}$$

$$M_x = 997890. \text{ Nmm}$$

$$x_m = 18. \text{ mm}$$

$$u_m = 17.29 \text{ mm}$$

$$v_m = -26.86 \text{ mm}$$

$$\sigma_m = N/A - Mcv/J_u - Msu/J_v = 219.7 \text{ N/mm}^2$$

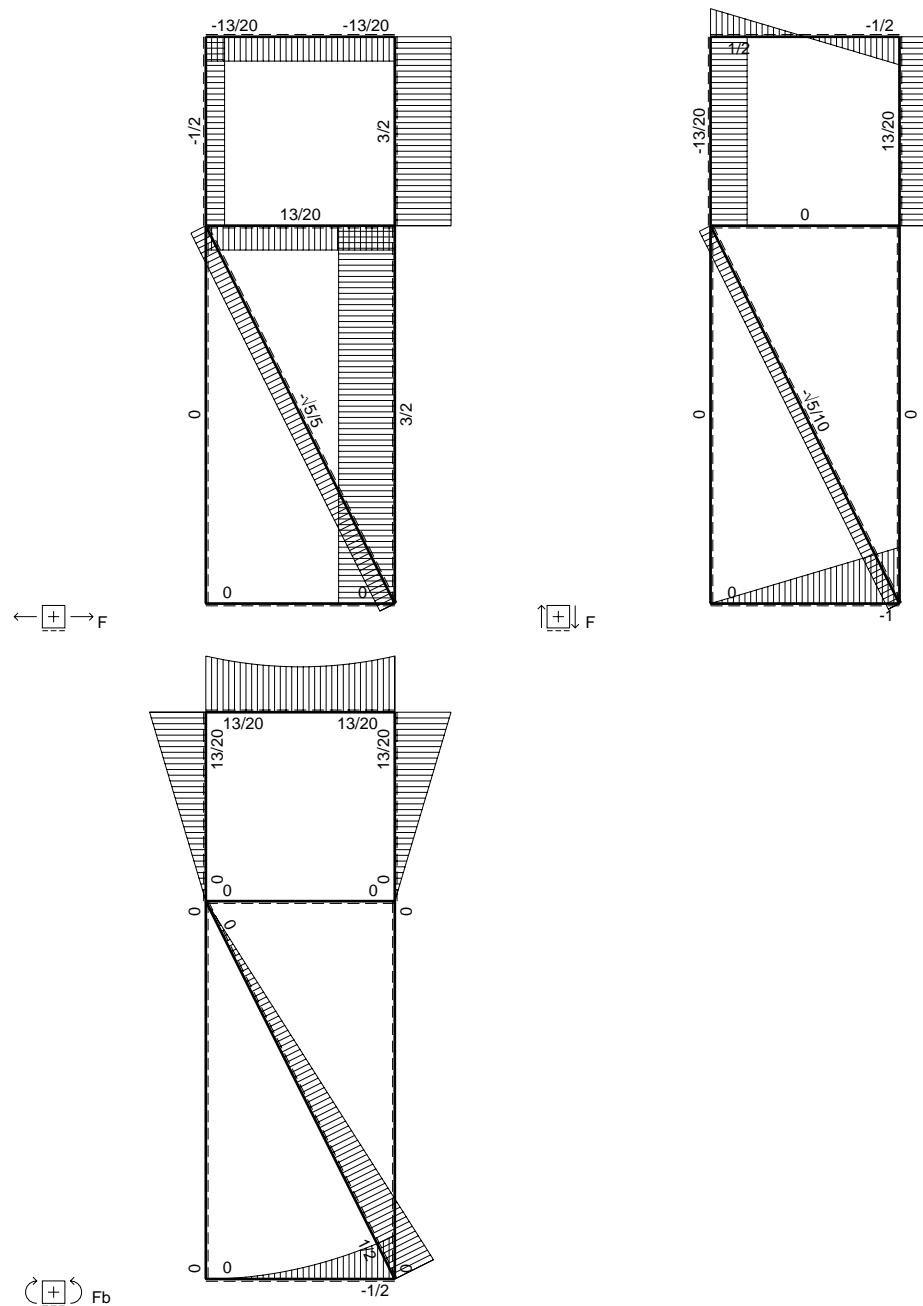
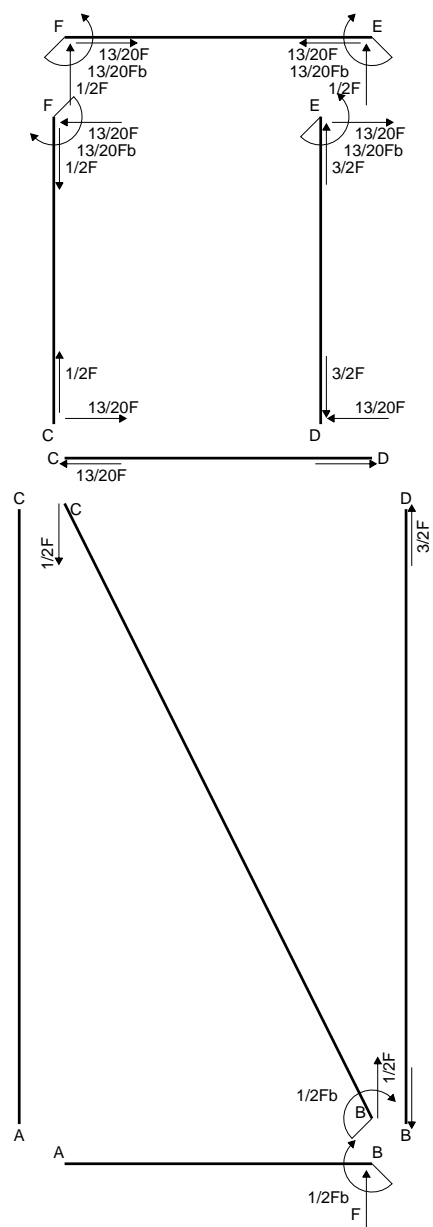

$$L_{DE}^{xx} = \int_0^b (x^2/b^2) 1/EJ dx = [1/3 x^3/b^2]_0^b 1/EJ$$

$$= (1/3 b) 1/EJ = 1/3 b/EJ$$

$$L_{ED}^{xx} = \int_0^b (1 - 2x/b + x^2/b^2) 1/EJ dx = [x - x^2/b + 1/3 x^3/b^2]_0^b 1/EJ$$

$$= (b - b + 1/3 b) 1/EJ = 1/3 b/EJ$$

$$L_{EF}^{xx} = \int_0^b (1) 1/EJ dx = [x]_0^b 1/EJ$$

$$= (b) 1/EJ = b/EJ$$

$$L_{FE}^{xx} = \int_0^b (1) 1/EJ dx = [x]_0^b 1/EJ$$

$$= (b) 1/EJ = b/EJ$$

$$L_{FC}^{xx} = \int_0^b (1 - 2x/b + x^2/b^2) 1/EJ dx = [x - x^2/b + 1/3 x^3/b^2]_0^b 1/EJ$$

$$= (b - b + 1/3 b) 1/EJ = 1/3 b/EJ$$

$$L_{CF}^{xx} = \int_0^b (x^2/b^2) 1/EJ dx = [1/3 x^3/b^2]_0^b 1/EJ$$

$$= (1/3 b) 1/EJ = 1/3 b/EJ$$

$$L_{EF}^{xo} = \int_0^b (1/2 x/b - 1/2 x^2/b^2) Fb 1/EJ dx + \int_0^b (1) \theta dx = [1/4 x^2/b - 1/6 x^3/b^2]_0^b Fb 1/EJ + [x]_0^b \theta$$

$$= (1/4 b - 1/6 b) Fb 1/EJ + (b) \theta = 13/12 Fb^2/EJ$$

$$L_{FE}^{xo} = \int_0^b (1/2 x/b - 1/2 x^2/b^2) Fb 1/EJ dx + \int_0^b (-1) \theta dx = [1/4 x^2/b - 1/6 x^3/b^2]_0^b Fb 1/EJ + [-x]_0^b \theta$$

$$= (1/4 b - 1/6 b) Fb 1/EJ + (-b) \theta = 13/12 Fb^2/EJ$$

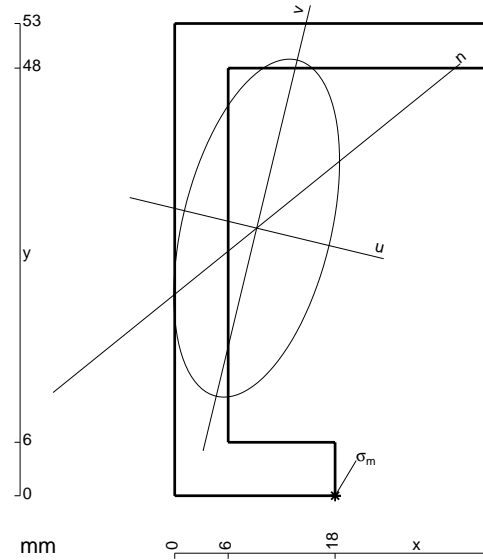

- A = 540. mm²
- J_x = 194387. mm⁴
- J_y = 46742. mm⁴
- J_{xy} = 37742. mm⁴
- J_u = 203476. mm⁴
- J_v = 37654. mm⁴
- α = arctg(2J_{xy}/(J_y-J_x))/2 = -.2363
- c = cos α = .9722
- s = sin α = -.2341
- x_g = 9.2 mm
- y_g = 30.03 mm
- N = 3450. N
- T_y = 1495. N
- M_x = 986700. Nmm
- x_m = 18. mm
- u_m = 15.59 mm
- v_m = -27.14 mm
- σ_m = N/A - Mcv/J_u - Msu/J_v = 230. N/mm²

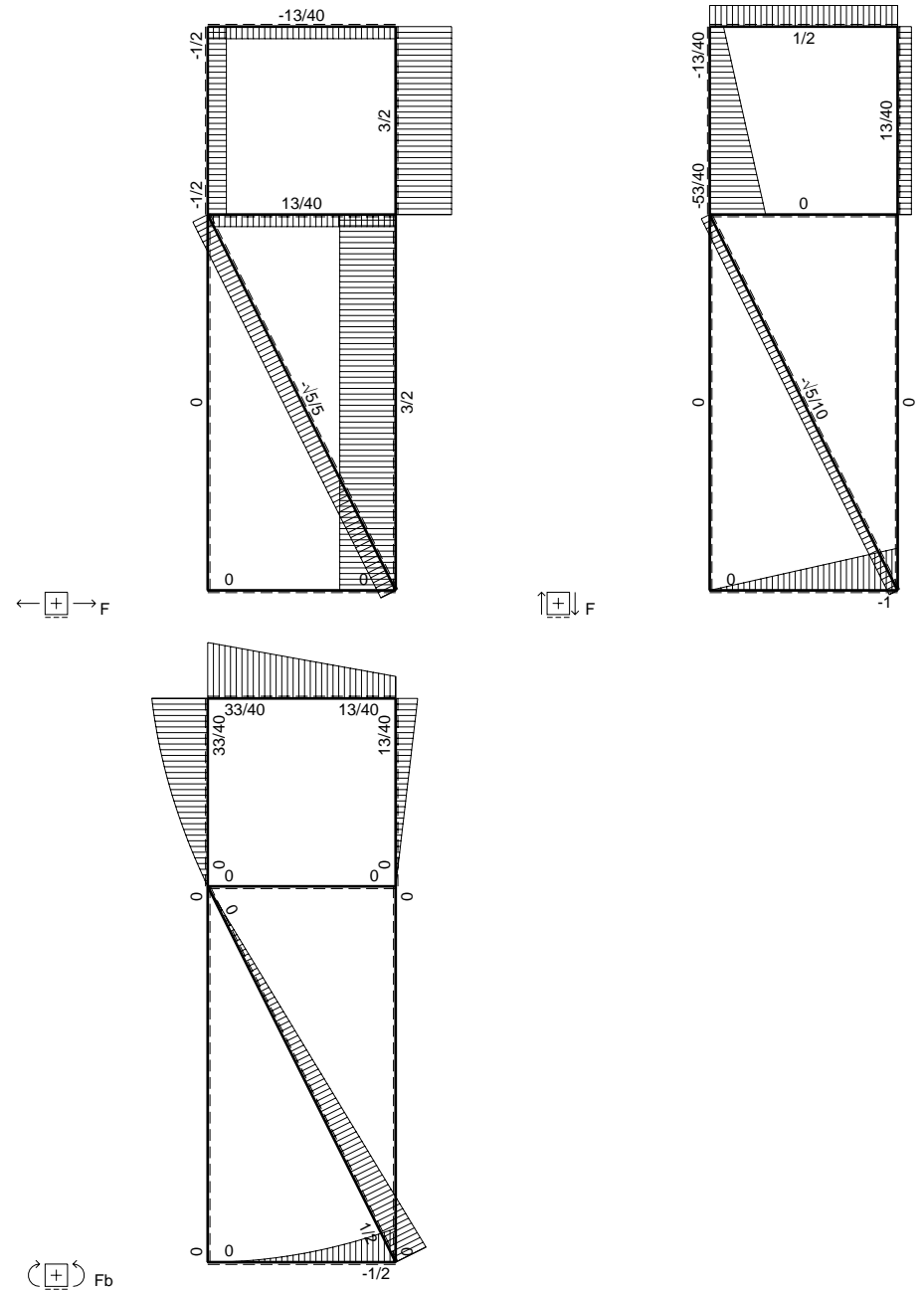
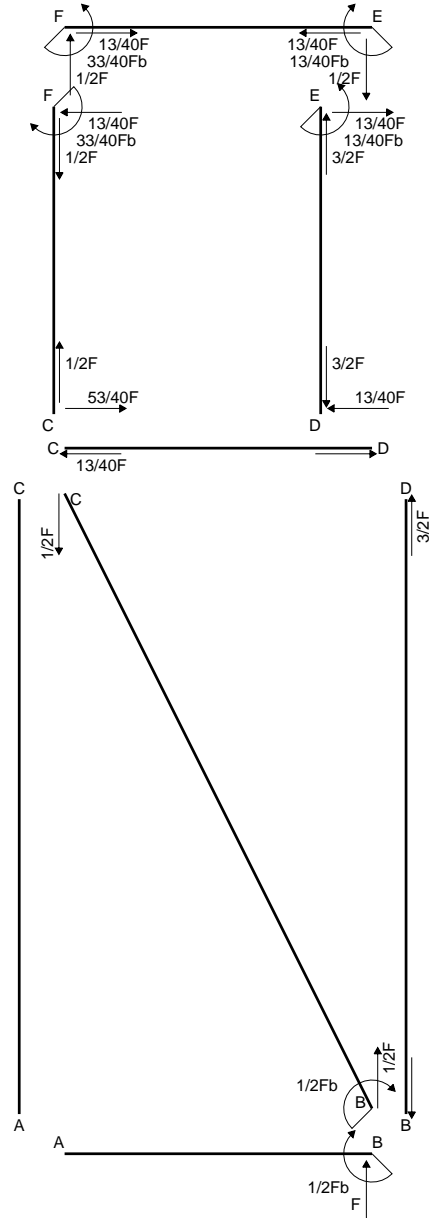

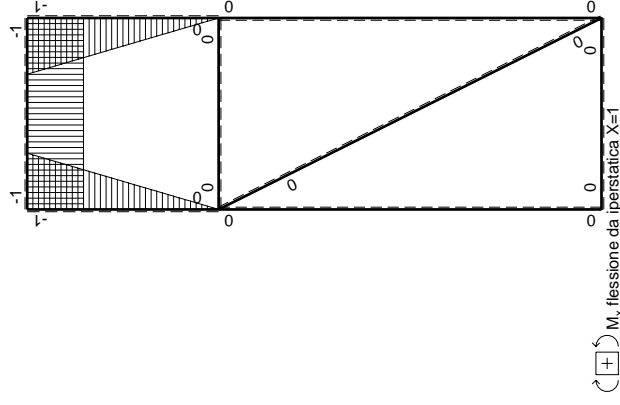
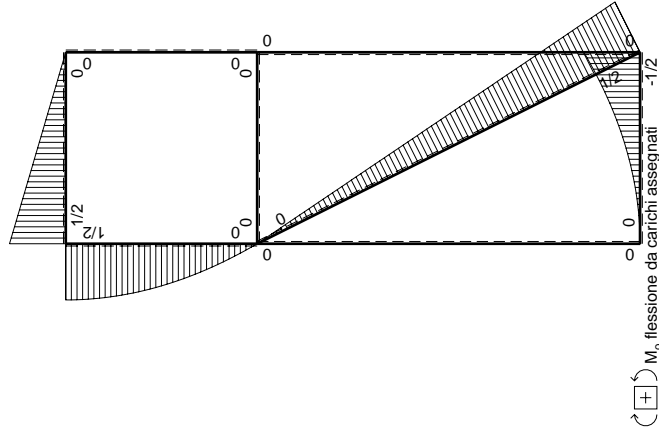
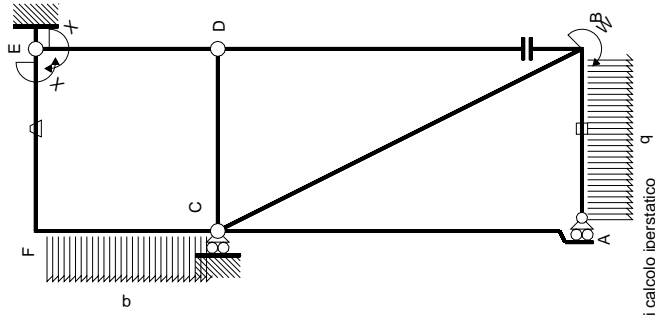

Quadro contributi PLV per iperstatica $X=W_{EF}$

\rightarrow	$M^x(x)$	$M^0(x)$	θ	$M^x M_0$	$M^x \theta$	$M^x M_x$	$\int M^x (M_0/EJ + \theta) dx$	$\int M^x M_x/EJ dx$
AB b	0	$-1/2qx^2$	0	0	0	0	0	0
BA b	0	$1/2Fb-Fx+1/2qx^2$	0	0	0	0	0	0
BC $\sqrt{5}b$	0	$1/2Fb-\sqrt{5}/10Fx$	0	0	0	0	0	0
AC 2b	0	0	0	0	0	0	0	0
CA 2b	0	0	0	0	0	0	0	0
DB 2b	0	0	0	0	0	0	0	0
BD 2b	0	0	0	0	0	0	0	0
DE b	-x/b	0	0	0	0	0	0	0
ED b	1-x/b	0	0	0	0	0	0	0
CD b	0	0	0	0	0	0	0	0
DC b	0	0	0	0	0	0	0	0
EF b	-1	$1/2Fx$	-Fb/EJ	-1/2Fx	Fb/EJ	1	$(-1/4+1)Fb^2/EJ$	Xb/EJ
FE b	1	$-1/2Fb+1/2Fx$	Fb/EJ	-1/2Fb+1/2Fx	Fb/EJ	1	$(-1/4+1)Fb^2/EJ$	Xb/EJ
FC b	-1+x/b	$1/2Fb-1/2qx^2$	0	$-1/2Fb+1/2Fx+1/2Fx^2/b-1/2qx^3/b$	0	0	$(-5/24+0)Fb^2/EJ$	$1/3Xb/EJ$
CF b	x/b	$-Fx+1/2qx^2$	0	$-Fx^2/b+1/2qx^3/b$	0	0	$13/24Fb^2/EJ$	$5/3Xb/EJ$
totali								
iperstatica $X=W_{EF}$								

Sviluppi di calcolo iperstatica

$$L_{DE}^{xx} = \int_0^b (x^2/b^2) 1/EJ dx = [1/3 x^3/b^2]_0^b 1/EJ$$

$$= (1/3 b) 1/EJ = 1/3 b/EJ$$

$$L_{ED}^{xx} = \int_0^b (1 - 2x/b + x^2/b^2) 1/EJ dx = [x - x^2/b + 1/3 x^3/b^2]_0^b 1/EJ$$

$$= (b - b + 1/3 b) 1/EJ = 1/3 b/EJ$$

$$L_{EF}^{xx} = \int_0^b (1) 1/EJ dx = [x]_0^b 1/EJ$$

$$= (b) 1/EJ = b/EJ$$

$$L_{FE}^{xx} = \int_0^b (1) 1/EJ dx = [x]_0^b 1/EJ$$

$$= (b) 1/EJ = b/EJ$$

$$L_{FC}^{xx} = \int_0^b (1 - 2x/b + x^2/b^2) 1/EJ dx = [x - x^2/b + 1/3 x^3/b^2]_0^b 1/EJ$$

$$= (b - b + 1/3 b) 1/EJ = 1/3 b/EJ$$

$$L_{CF}^{xx} = \int_0^b (x^2/b^2) 1/EJ dx = [1/3 x^3/b^2]_0^b 1/EJ$$

$$= (1/3 b) 1/EJ = 1/3 b/EJ$$

$$L_{EF}^{xo} = \int_0^b (-1/2 x/b) Fb 1/EJ dx + \int_0^b (1) \theta dx = [-1/4 x^2/b]_0^b Fb 1/EJ + [x]_0^b \theta$$

$$= (-1/4 b) Fb 1/EJ + (b) \theta = 3/4 Fb^2/EJ$$

$$L_{FE}^{xo} = \int_0^b (-1/2 + 1/2 x/b) Fb 1/EJ dx + \int_0^b (-1) \theta dx = [-1/2 x + 1/4 x^2/b]_0^b Fb 1/EJ + [-x]_0^b \theta$$

$$= (-1/2 b + 1/4 b) Fb 1/EJ + (-b) \theta = 3/4 Fb^2/EJ$$

$$L_{FC}^{xo} = \int_0^b (-1/2 + 1/2 x/b + 1/2 x^2/b^2 - 1/2 x^3/b^3) Fb 1/EJ dx$$

$$= [-1/2 x + 1/4 x^2/b + 1/6 x^3/b^2 - 1/8 x^4/b^3]_0^b Fb 1/EJ$$

$$= (-1/2 b + 1/4 b + 1/6 b - 1/8 b) Fb 1/EJ = -5/24 Fb^2/EJ$$

$$L_{CF}^{xo} = \int_0^b (-x^2/b^2 + 1/2 x^3/b^3) Fb 1/EJ dx = [-1/3 x^3/b^2 + 1/8 x^4/b^3]_0^b Fb 1/EJ$$

$$= (-1/3 b + 1/8 b) Fb 1/EJ = -5/24 Fb^2/EJ$$

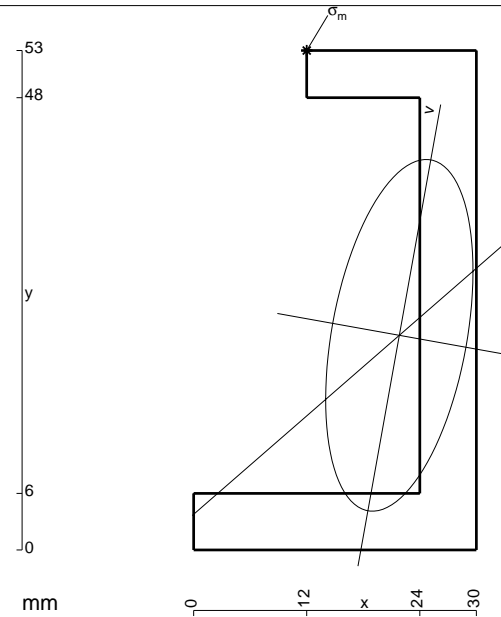

- A = 522. mm²
- J_x = 181840. mm⁴
- J_y = 31881. mm⁴
- J_{xy} = 27745. mm⁴
- J_u = 186808. mm⁴
- J_v = 26912. mm⁴
- α = arctg(2J_{xy}/(J_y-J_x))/2 = -.1772
- c = cos α = .9843
- s = sin α = -.1763
- x_g = 21.83 mm
- y_g = 22.78 mm
- N = -835. N
- T_y = -542.8 N
- M_x = 964425. Nmm
- x_m = 12. mm
- y_m = 53. mm
- u_m = -15. mm
- v_m = 28.02 mm
- σ_m = N/A - Mcv/J_u - Msu/J_v = -238.8 N/mm²

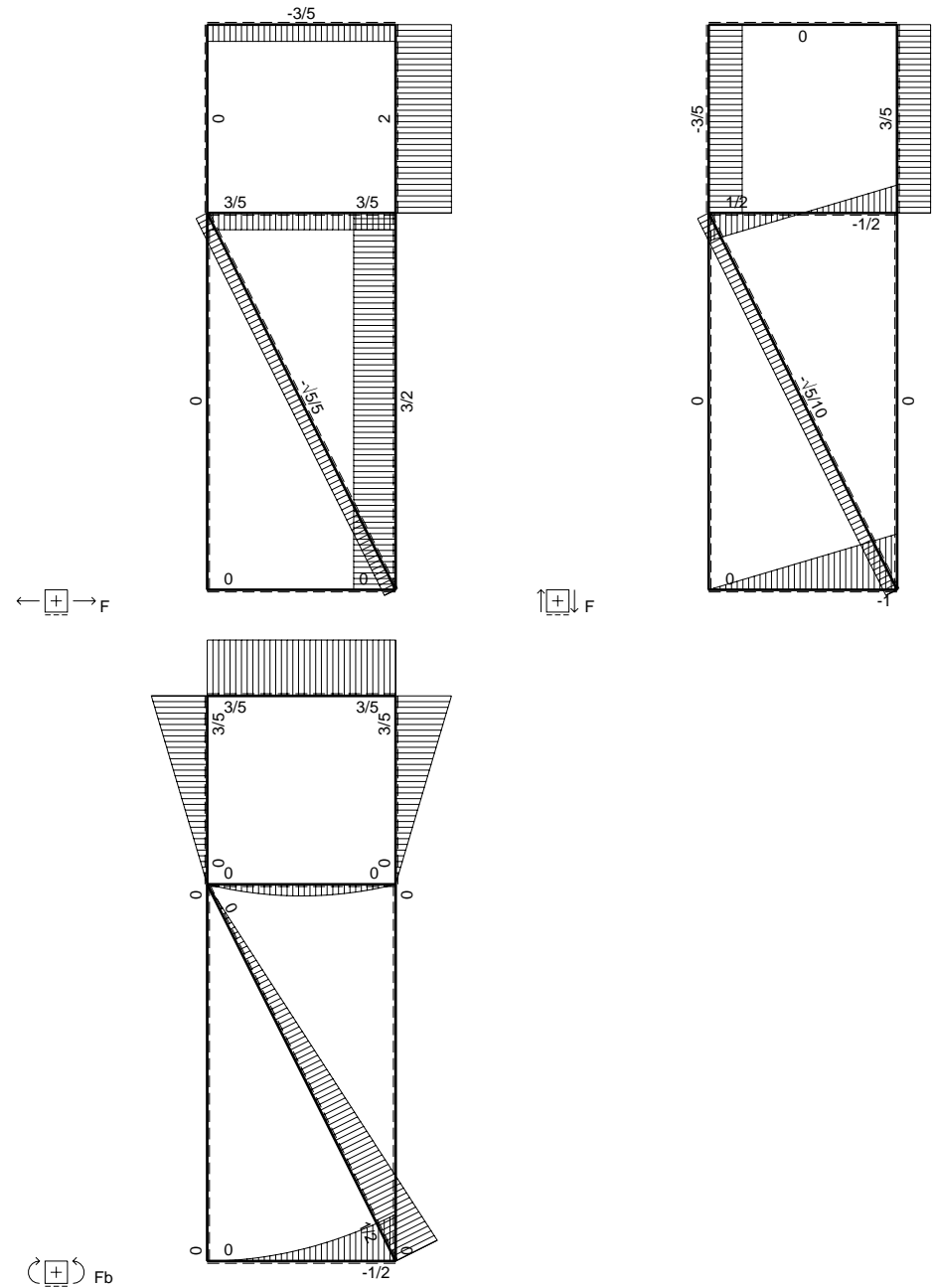
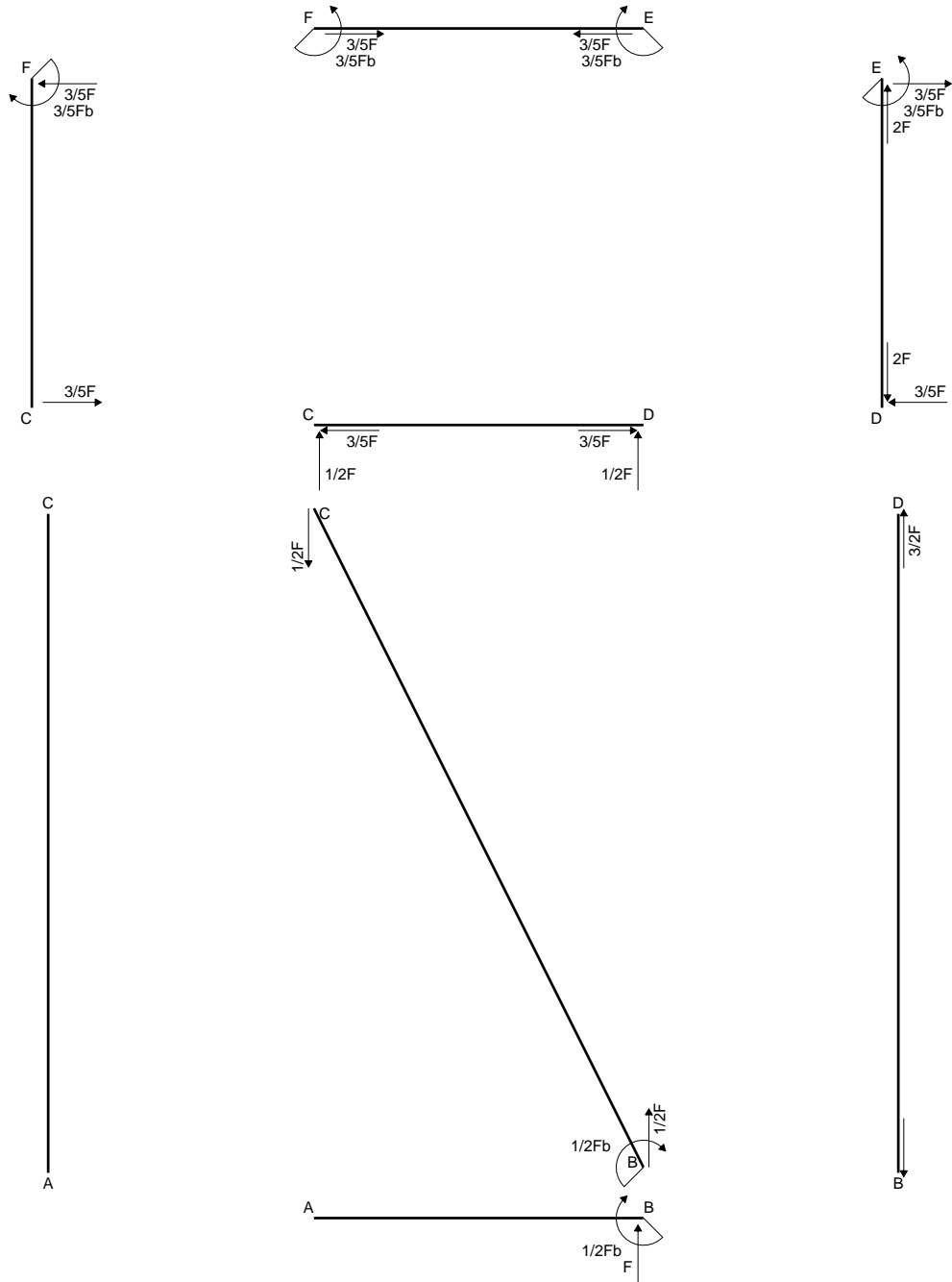

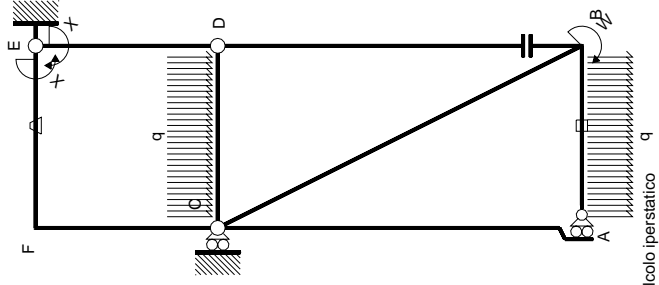

Schema di calcolo iperstatico

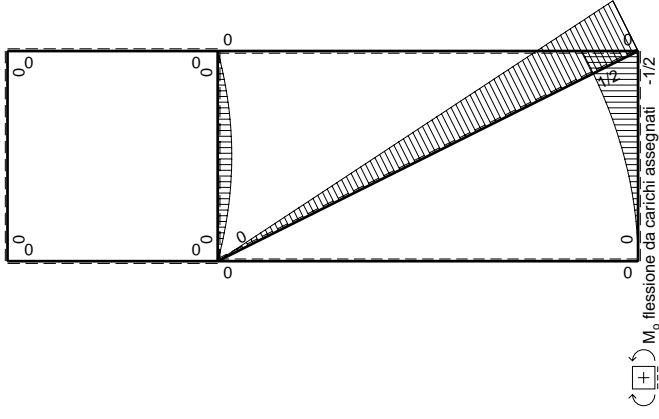

M_0 flessione da carichi assegnati -1/2

Quadro contributi PLV per iperstatica $X=W_{EF}$

\rightarrow	$M_x(x)$	$M_0(x)$	θ	$M_x M_0$	$M_x \theta$	$M_x M_x$	$\int M_x(M_0/EJ+\theta)dx$	$\int X M_x M_x/EJ dx$
AB b	0	$-1/2qx^2$	0	0	0	0	0+0	0
BA b	0	$1/2Fb-Fx+1/2qx^2$	0	0	0	0	0+0	0
BC $\sqrt{5}b$	0	$1/2Fb-\sqrt{5}/10Fx$	0	0	0	0	0	0
AC 2b	0	0	0	0	0	0	0+0	0
CA 2b	0	0	0	0	0	0	0+0	0
DB 2b	0	0	0	0	0	0	0+0	0
BD 2b	0	0	0	0	0	0	0+0	0
DE b	$-x/b$	0	0	0	0	x^2/b^2	0+0	$1/3Xb/EJ$
ED b	$1-x/b$	0	0	0	0	$1-2x/b+x^2/b^2$	0+0	0
CD b	0	$1/2Fx-1/2qx^2$	0	0	0	0	0+0	0
DC b	0	$-1/2Fx+1/2qx^2$	0	0	0	0	0+0	0
EF b	-1	0	$-Fb/EJ$	0	Fb/EJ	1	$(0+1)Fb^2/EJ$	Xb/EJ
FE b	1	0	Fb/EJ	0	Fb/EJ	1		
FC b	$-1+x/b$	0	0	0	0	$1-2x/b+x^2/b^2$	0+0	$1/3Xb/EJ$
CF b	x/b	0	0	0	0	x^2/b^2	Fb^2/EJ	$5/3Xb/EJ$
	totali							
	iperstatica $X=W_{EF}$							

Sviluppi di calcolo iperstatica

M_x flessione da iperstatica $X=1$

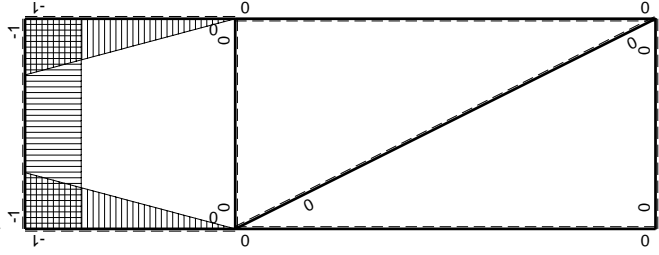

$$L_{DE}^{xx} = \int_0^b (x^2/b^2) 1/EJ dx = [1/3 x^3/b^2]_0^b 1/EJ$$

$$= (1/3 b) 1/EJ = 1/3 b/EJ$$

$$L_{ED}^{xx} = \int_0^b (1 - 2x/b + x^2/b^2) 1/EJ dx = [x - x^2/b + 1/3 x^3/b^2]_0^b 1/EJ$$

$$= (b - b + 1/3 b) 1/EJ = 1/3 b/EJ$$

$$L_{EF}^{xx} = \int_0^b (1) 1/EJ dx = [x]_0^b 1/EJ$$

$$= (b) 1/EJ = b/EJ$$

$$L_{FE}^{xx} = \int_0^b (1) 1/EJ dx = [x]_0^b 1/EJ$$

$$= (b) 1/EJ = b/EJ$$

$$L_{FC}^{xx} = \int_0^b (1 - 2x/b + x^2/b^2) 1/EJ dx = [x - x^2/b + 1/3 x^3/b^2]_0^b 1/EJ$$

$$= (b - b + 1/3 b) 1/EJ = 1/3 b/EJ$$

$$L_{CF}^{xx} = \int_0^b (x^2/b^2) 1/EJ dx = [1/3 x^3/b^2]_0^b 1/EJ$$

$$= (1/3 b) 1/EJ = 1/3 b/EJ$$

$$L_{EF}^{xo} = \int_0^b (1) \theta dx = [x]_0^b \theta$$

$$= (b) \theta = Fb^2/EJ$$

$$L_{FE}^{xo} = \int_0^b (-1) \theta dx = [-x]_0^b \theta$$

$$= (-b) \theta = Fb^2/EJ$$

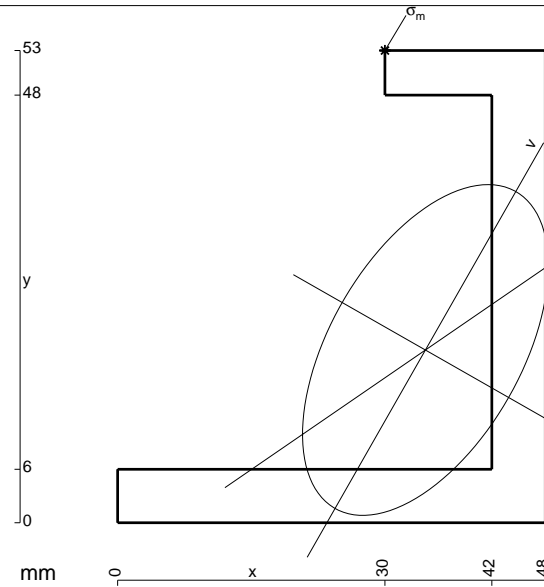

- A = 630. mm²
- J_x = 217160. mm⁴
- J_y = 119838. mm⁴
- J_{xy} = 82299. mm⁴
- J_u = 264108. mm⁴
- J_v = 72891. mm⁴
- α = artg(2J_{xy}/(J_y-J_x))/2 = -5184
- c = cosα = .8686
- s = sinα = -.4955
- x_g = 34.54 mm
- y_g = 19.39 mm
- N = -2316. N
- M_x = 856920. Nmm
- x_m = 30. mm
- y_m = 53. mm
- u_m = -20.6 mm
- v_m = 26.95 mm
- σ_m = N/A - Mcv/J_u - Msu/J_v = -199.6 N/mm²

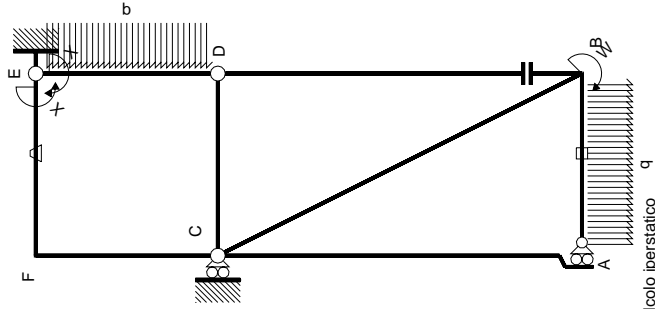

Schema di calcolo iperstatico

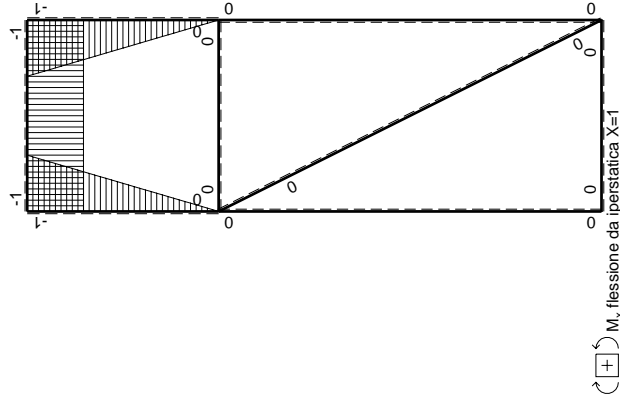

M_x flessione da iperstatica $X=1$

Quadro contributi PLV per iperstatica $X=W_{EF}$

\rightarrow	$M_x(x)$	$M_0(x)$	θ	$M_x M_0$	$M_x \theta$	$M_x M_x$	$\int M_x(M_0/EJ+\theta)dx$	$\int M_x M_x/EJ dx$
AB b	0	$-1/2qx^2$	0	0	0	0	0+0	0
BA b	0	$1/2Fb-Fx+1/2qx^2$	0	0	0	0	0	0
BC $\sqrt{5}b$	0	$1/2Fb-\sqrt{5}/10Fx$	0	0	0	0	0+0	0
CA 2b	0	0	0	0	0	0	0+0	0
DB 2b	0	0	0	0	0	0	0+0	0
BD 2b	0	0	0	0	0	0	0+0	0
DE b	$-x/b$	$-1/2Fx+1/2qx^2$	0	$1/2F^2x^2/b-1/2qx^3/b$	0	0	x^2/b^2	0
ED b	$1-x/b$	$1/2Fx-1/2qx^2$	0	$1/2Fx-Fx^2/b+1/2qx^3/b$	0	0	$1-2x/b+x^2/b^2$	$1/3xb/EJ$
CD b	0	0	0	0	0	0	0+0	0
DC b	0	0	0	0	0	0	0+0	0
EF b	-1	$1/2Fx$	$-Fb/EJ$	$-1/2Fx$	Fb/EJ	1	$(-1/4+1)Fb^2/EJ$	xb/EJ
FE b	1	$-1/2Fb+1/2Fx$	Fb/EJ	$-1/2Fb+1/2Fx$	Fb/EJ	1	$(-1/4+1)Fb^2/EJ$	xb/EJ
FC b	$-1+x/b$	$1/2Fb-1/2Fx$	0	$-1/2Fb+Fx-1/2Fx^2/b$	0	0	$1-2x/b+x^2/b^2$	$1/3xb/EJ$
CF b	x/b	$-1/2Fx$	0	$-1/2Fx^2/b$	0	0	x^2/b^2	$1/3xb/EJ$
totali								$5/8Fb^2/EJ$
								$-3/8Fb$

Sviluppi di calcolo iperstatica

$$L_{DE}^{xx} = \int_0^b (x^2/b^2) 1/EJ dx = [1/3 x^3/b^2]_0^b 1/EJ$$

$$= (1/3 b) 1/EJ = 1/3 b/EJ$$

$$L_{ED}^{xx} = \int_0^b (1 - 2x/b + x^2/b^2) 1/EJ dx = [x - x^2/b + 1/3 x^3/b^2]_0^b 1/EJ$$

$$= (b - b + 1/3 b) 1/EJ = 1/3 b/EJ$$

$$L_{EF}^{xx} = \int_0^b (1) 1/EJ dx = [x]_0^b 1/EJ$$

$$= (b) 1/EJ = b/EJ$$

$$L_{FE}^{xx} = \int_0^b (1) 1/EJ dx = [x]_0^b 1/EJ$$

$$= (b) 1/EJ = b/EJ$$

$$L_{FC}^{xx} = \int_0^b (1 - 2x/b + x^2/b^2) 1/EJ dx = [x - x^2/b + 1/3 x^3/b^2]_0^b 1/EJ$$

$$= (b - b + 1/3 b) 1/EJ = 1/3 b/EJ$$

$$L_{CF}^{xx} = \int_0^b (x^2/b^2) 1/EJ dx = [1/3 x^3/b^2]_0^b 1/EJ$$

$$= (1/3 b) 1/EJ = 1/3 b/EJ$$

$$L_{DE}^{xo} = \int_0^b (1/2 x^2/b^2 - 1/2 x^3/b^3) Fb 1/EJ dx = [1/6 x^3/b^2 - 1/8 x^4/b^3]_0^b Fb 1/EJ$$

$$= (1/6 b - 1/8 b) Fb 1/EJ = 1/24 Fb^2/EJ$$

$$L_{ED}^{xo} = \int_0^b (1/2 x/b - x^2/b^2 + 1/2 x^3/b^3) Fb 1/EJ dx = [1/4 x^2/b - 1/3 x^3/b^2 + 1/8 x^4/b^3]_0^b Fb 1/EJ$$

$$= (1/4 b - 1/3 b + 1/8 b) Fb 1/EJ = 1/24 Fb^2/EJ$$

$$L_{EF}^{xo} = \int_0^b (-1/2 x/b) Fb 1/EJ dx + \int_0^b (1) \theta dx = [-1/4 x^2/b]_0^b Fb 1/EJ + [x]_0^b \theta$$

$$= (-1/4 b) Fb 1/EJ + (b) \theta = 3/4 Fb^2/EJ$$

$$L_{FE}^{xo} = \int_0^b (-1/2 + 1/2 x/b) Fb 1/EJ dx + \int_0^b (-1) \theta dx = [-1/2 x + 1/4 x^2/b]_0^b Fb 1/EJ + [-x]_0^b \theta$$

$$= (-1/2 b + 1/4 b) Fb 1/EJ + (-b) \theta = 3/4 Fb^2/EJ$$

$$L_{FC}^{xo} = \int_0^b (-1/2 + x/b - 1/2 x^2/b^2) Fb 1/EJ dx = [-1/2 x + 1/2 x^2/b - 1/6 x^3/b^2]_0^b Fb 1/EJ$$

$$= (-1/2 b + 1/2 b - 1/6 b) Fb 1/EJ = -1/6 Fb^2/EJ$$

$$L_{CF}^{xo} = \int_0^b (-1/2 x^2/b^2) Fb 1/EJ dx = [-1/6 x^3/b^2]_0^b Fb 1/EJ$$

$$= (-1/6 b) Fb 1/EJ = -1/6 Fb^2/EJ$$

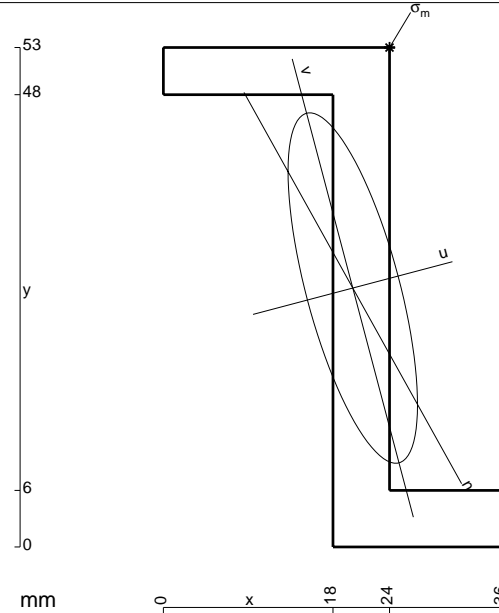

- A = 480. mm²
- J_x = 165988. mm⁴
- J_y = 22651. mm⁴
- J_{xy} = -40727. mm⁴
- J_u = 176751. mm⁴
- J_v = 11888. mm⁴
- α = arctg(2J_{xy}/(J_y-J_x))/2 = .2584
- c = cos α = .9668
- s = sin α = .2555
- x_g = 20.1 mm
- y_g = 27.48 mm
- N = -1470. N
- T_y = 840. N
- M_x = 588000. Nmm
- x_m = 24. mm
- y_m = 53. mm
- u_m = 10.29 mm
- v_m = 23.68 mm
- σ_m = N/A - Mc_v/J_u - Ms_u/J_v = -209.3 N/mm²

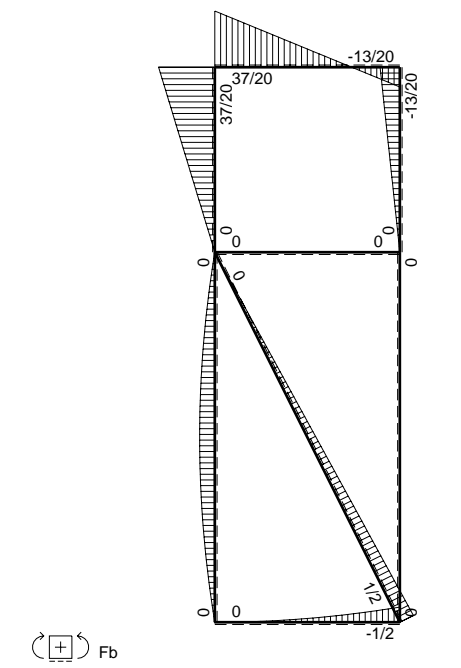
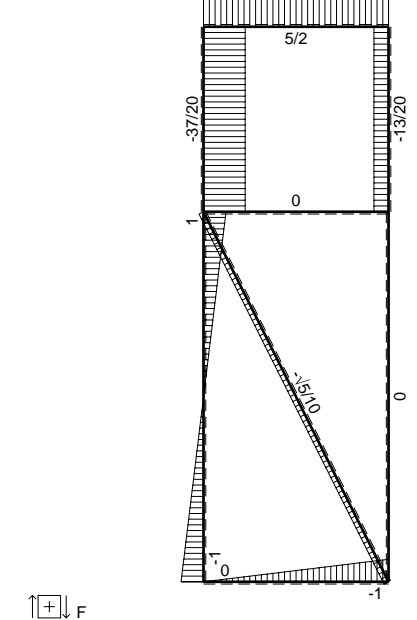
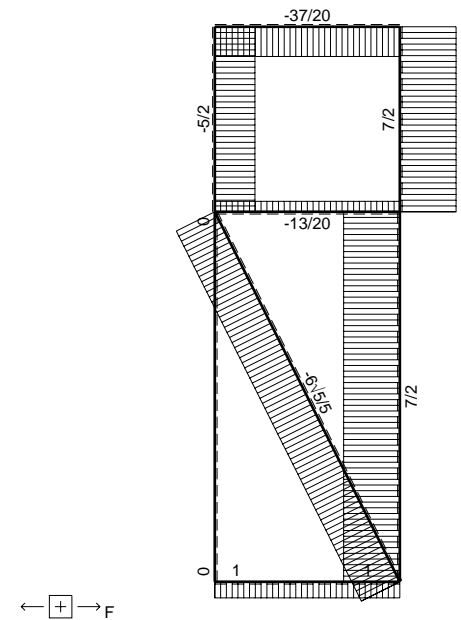
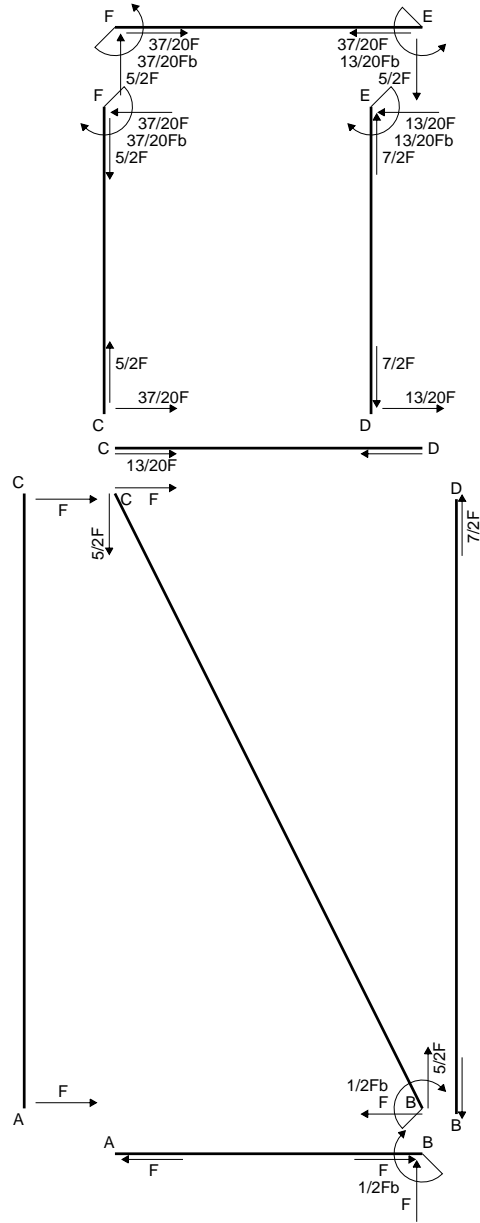

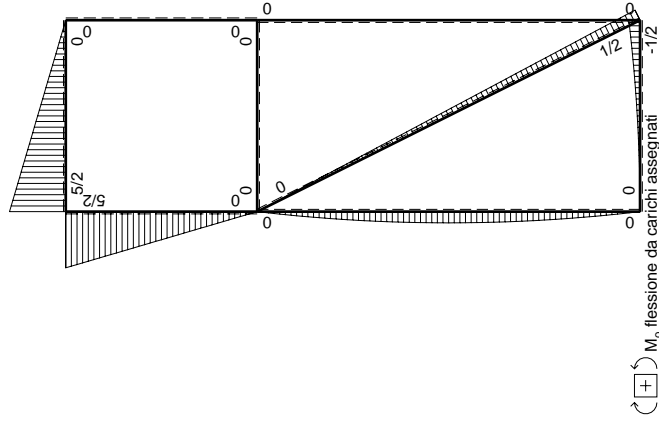
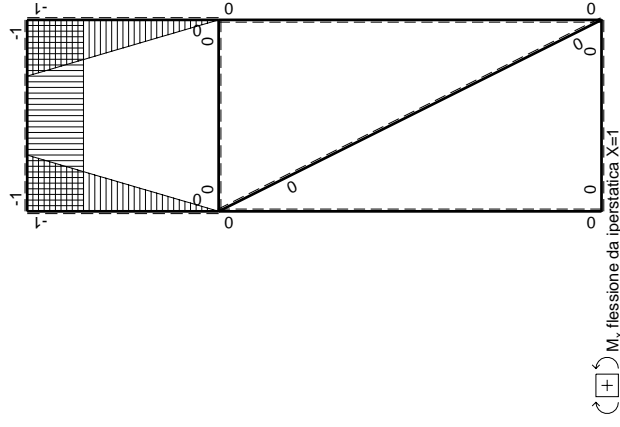
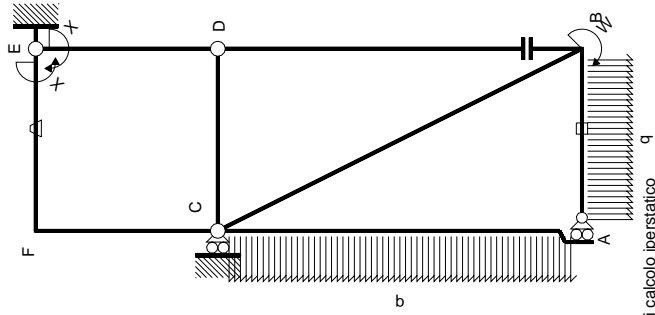

Quadro contributi PLV per iperstatica $X=W_{EP}$

\rightarrow	$M(x)$	$M_0(x)$	θ	$M M_0$	$M \theta$	$M M_x$	$\int M_x(M_0/EJ+\theta)dx$	$\int M_x M_x/EJdx$
AB b	0	$-1/2qx^2$	0	0	0	0	0	0
BA b	0	$1/2Fb-Fx+1/2qx^2$	0	0	0	0	0	0
BC $\sqrt{5}b$	0	$1/2Fb-\sqrt{5}/10Fx$	0	0	0	0	0	0
AC 2b	0	$-Fx+1/2qx^2$	0	0	0	0	0	0
CA 2b	0	$Fx-1/2qx^2$	0	0	0	0	0	0
DB 2b	0	0	0	0	0	0	0	0
BD 2b	0	0	0	0	0	0	0	0
DE b	$-x/b$	0	0	0	0	x^2/b^2	0	0
ED b	$1-x/b$	0	0	0	0	$1-2x/b+x^2/b^2$	0	0
CD b	0	0	0	0	0	0	0	0
DC b	0	0	0	0	0	0	0	0
EF b	-1	$5/2Fx$	$-Fb/EJ$	$-5/2Fx$	Fb/EJ	1	$(-5/4+1)Fb^2/EJ$	Xb/EJ
FE b	1	$-5/2Fb+5/2Fx$	Fb/EJ	$-5/2Fb+5/2Fx$	Fb/EJ	1	$(-5/4+1)Fb^2/EJ$	Xb/EJ
FC b	$-1+x/b$	$5/2Fb-5/2Fx$	0	$-5/2Fb+5Fx-5/2Fx^2/b$	0	$1-2x/b+x^2/b^2$	$(-5/6+0)Fb^2/EJ$	$1/3Xb/EJ$
CF b	x/b	$-5/2Fx$	0	$-5/2Fx^2/b$	0	x^2/b^2	$(-5/6+0)Fb^2/EJ$	$1/3Xb/EJ$
totali							$-13/12Fb^2/EJ$	$5/3Xb/EJ$
								$13/20Fb$

Sviluppi di calcolo iperstatica

$$L_{DE}^{xx} = \int_0^b (x^2/b^2) 1/EJ dx = [1/3 x^3/b^2]_0^b 1/EJ$$

$$= (1/3 b) 1/EJ = 1/3 b/EJ$$

$$L_{ED}^{xx} = \int_0^b (1 - 2x/b + x^2/b^2) 1/EJ dx = [x - x^2/b + 1/3 x^3/b^2]_0^b 1/EJ$$

$$= (b - b + 1/3 b) 1/EJ = 1/3 b/EJ$$

$$L_{EF}^{xx} = \int_0^b (1) 1/EJ dx = [x]_0^b 1/EJ$$

$$= (b) 1/EJ = b/EJ$$

$$L_{FE}^{xx} = \int_0^b (1) 1/EJ dx = [x]_0^b 1/EJ$$

$$= (b) 1/EJ = b/EJ$$

$$L_{FC}^{xx} = \int_0^b (1 - 2x/b + x^2/b^2) 1/EJ dx = [x - x^2/b + 1/3 x^3/b^2]_0^b 1/EJ$$

$$= (b - b + 1/3 b) 1/EJ = 1/3 b/EJ$$

$$L_{CF}^{xx} = \int_0^b (x^2/b^2) 1/EJ dx = [1/3 x^3/b^2]_0^b 1/EJ$$

$$= (1/3 b) 1/EJ = 1/3 b/EJ$$

$$L_{EF}^{xo} = \int_0^b (-5/2 x/b) Fb 1/EJ dx + \int_0^b (1) \theta dx = [-5/4 x^2/b]_0^b Fb 1/EJ + [x]_0^b \theta$$

$$= (-5/4 b) Fb 1/EJ + (b) \theta = -1/4 Fb^2/EJ$$

$$L_{FE}^{xo} = \int_0^b (-5/2 + 5/2 x/b) Fb 1/EJ dx + \int_0^b (-1) \theta dx = [-5/2 x + 5/4 x^2/b]_0^b Fb 1/EJ + [-x]_0^b \theta$$

$$= (-5/2 b + 5/4 b) Fb 1/EJ + (-b) \theta = -1/4 Fb^2/EJ$$

$$L_{FC}^{xo} = \int_0^b (-5/2 + 5x/b - 5/2 x^2/b^2) Fb 1/EJ dx = [-5/2 x + 5/2 x^2/b - 5/6 x^3/b^2]_0^b Fb 1/EJ$$

$$= (-5/2 b + 5/2 b - 5/6 b) Fb 1/EJ = -5/6 Fb^2/EJ$$

$$L_{CF}^{xo} = \int_0^b (-5/2 x^2/b^2) Fb 1/EJ dx = [-5/6 x^3/b^2]_0^b Fb 1/EJ$$

$$= (-5/6 b) Fb 1/EJ = -5/6 Fb^2/EJ$$

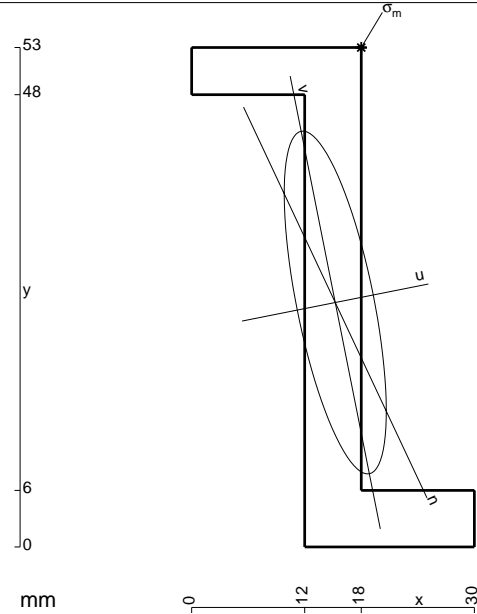

- A = 450. mm²
- J_x = 148960. mm⁴
- J_y = 13204. mm⁴
- J_{xy} = -28128. mm⁴
- J_u = 154557. mm⁴
- J_v = 7607. mm⁴
- α = arctg(2J_{xy}/(J_y-J_x))/2 = .1964
- c = cos α = .9808
- s = sin α = .1952
- x_g = 15.24 mm
- y_g = 25.94 mm
- N = -1775. N
- T_y = -1314. N
- M_x = 577940. Nmm
- x_m = 18. mm
- y_m = 53. mm
- u_m = 7.988 mm
- v_m = 26. mm
- σ_m = N/A - Mc_v/J_u - Ms_u/J_v = -217.7 N/mm²

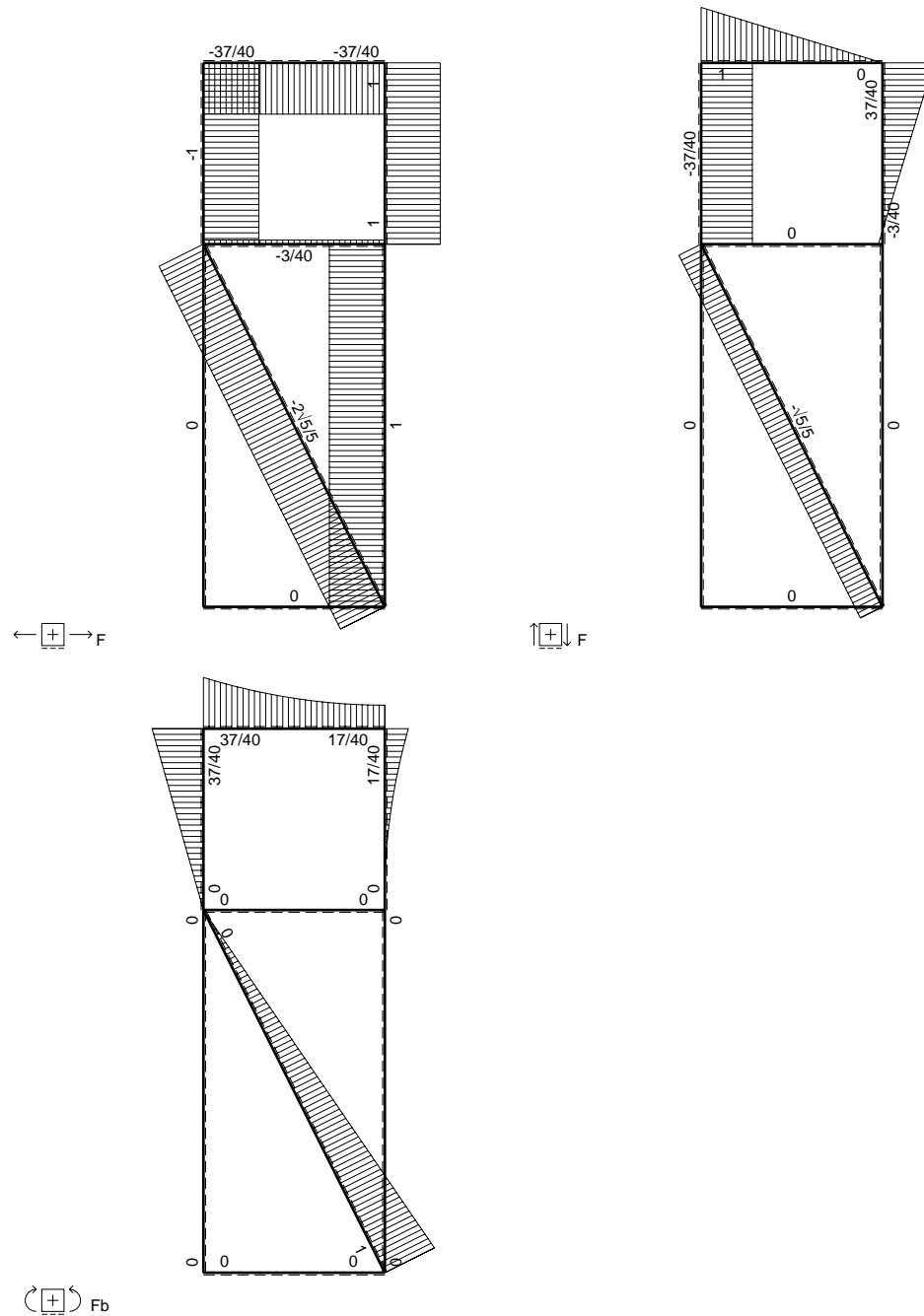
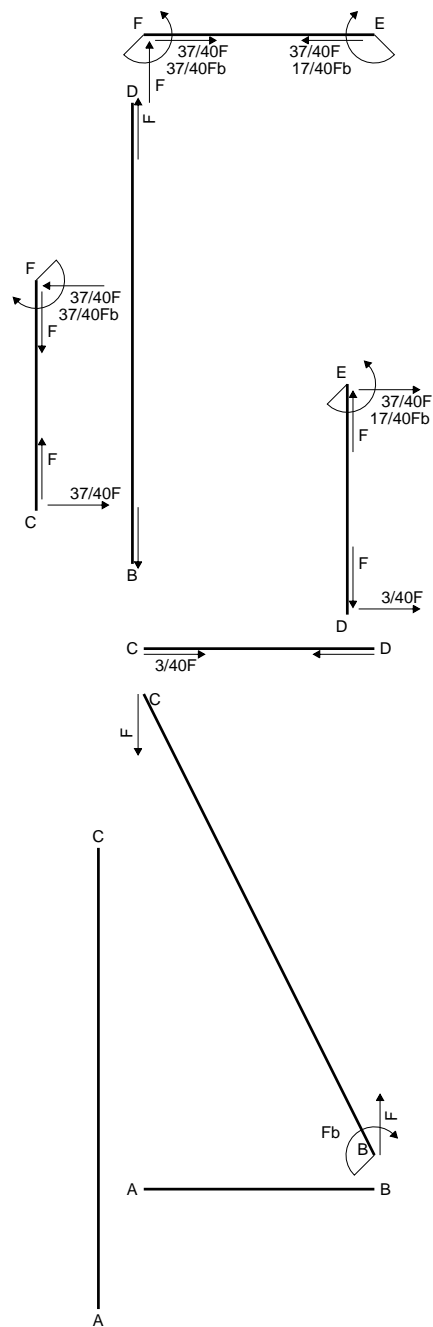

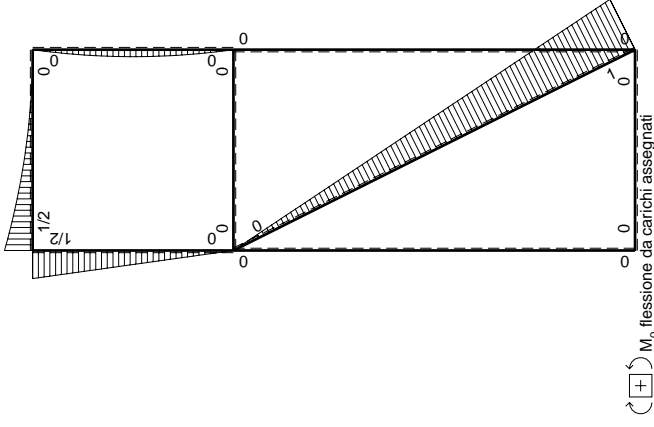
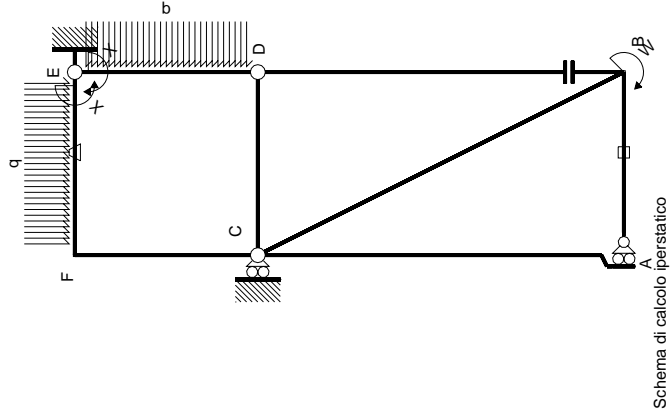

Quadro contributi PLV per iperstatica $X=W_{EF}$

\leftarrow	$M^x(x)$	$M^0(x)$	θ	$M^x M_0$	$M^x \theta$	$M^x M_x$	$\int M^x (M_0/EJ + \theta) dx$	$\int M^x M_x / E J dx$
AB b	0	0	0	0	0	0	0+0	0
BA b	0	0	0	0	0	0	0	0
BC $\sqrt{5}b$	0	$Fb\sqrt{5}/5Fx$	0	0	0	0	0+0	0
CA 2b	0	0	0	0	0	0	0+0	0
DB 2b	0	0	0	0	0	0	0+0	0
BD 2b	0	0	0	0	0	0	0+0	0
DE b	$-x/b$	$-1/2Fx + 1/2qx^2$	0	$1/2Fx^2/b - 1/2qx^3/b$	0	0	x^2/b^2	0
ED b	$1-x/b$	$1/2Fx - 1/2qx^2$	0	$1/2Fx - Fx^2/b + 1/2qx^3/b$	0	0	$1-2x/b+x^2/b^2$	$1/3Xb/EJ$
CD b	0	0	0	0	0	0	0+0	0
DC b	0	0	0	0	0	0	0+0	0
EF b	-1	$1/2qx^2$	$-Fb/EJ$	$-1/2Fx^2/b$	Fb/EJ	1	$(-1/6+1)Fb^2/EJ$	Xb/EJ
FE b	1	$-1/2Fb+Fx-1/2qx^2$	Fb/EJ	$-1/2Fb+Fx-1/2Fx^2/b$	Fb/EJ	1	$(-1/6+1)Fb^2/EJ$	Xb/EJ
FC b	$-1+x/b$	$1/2Fb-1/2Fx$	0	$-1/2Fb+Fx-1/2Fx^2/b$	0	0	$1-2x/b+x^2/b^2$	$1/3Xb/EJ$
CF b	x/b	$-1/2Fx$	0	$-1/2Fx^2/b$	0	0	x^2/b^2	$1/3Xb/EJ$
totali							$17/24Fb^2/EJ$	$5/3Xb/EJ$
							$-17/40Fb$	

Sviluppi di calcolo iperstatica

$$L_{DE}^{xx} = \int_0^b (x^2/b^2) 1/EJ dx = [1/3 x^3/b^2]_0^b 1/EJ$$

$$= (1/3 b) 1/EJ = 1/3 b/EJ$$

$$L_{ED}^{xx} = \int_0^b (1 - 2x/b + x^2/b^2) 1/EJ dx = [x - x^2/b + 1/3 x^3/b^2]_0^b 1/EJ$$

$$= (b - b + 1/3 b) 1/EJ = 1/3 b/EJ$$

$$L_{EF}^{xx} = \int_0^b (1) 1/EJ dx = [x]_0^b 1/EJ$$

$$= (b) 1/EJ = b/EJ$$

$$L_{FE}^{xx} = \int_0^b (1) 1/EJ dx = [x]_0^b 1/EJ$$

$$= (b) 1/EJ = b/EJ$$

$$L_{FC}^{xx} = \int_0^b (1 - 2x/b + x^2/b^2) 1/EJ dx = [x - x^2/b + 1/3 x^3/b^2]_0^b 1/EJ$$

$$= (b - b + 1/3 b) 1/EJ = 1/3 b/EJ$$

$$L_{CF}^{xx} = \int_0^b (x^2/b^2) 1/EJ dx = [1/3 x^3/b^2]_0^b 1/EJ$$

$$= (1/3 b) 1/EJ = 1/3 b/EJ$$

$$L_{DE}^{x_0} = \int_0^b (1/2 x^2/b^2 - 1/2 x^3/b^3) Fb 1/EJ dx = [1/6 x^3/b^2 - 1/8 x^4/b^3]_0^b Fb 1/EJ$$

$$= (1/6 b - 1/8 b) Fb 1/EJ = 1/24 Fb^2/EJ$$

$$L_{ED}^{x_0} = \int_0^b (1/2 x/b - x^2/b^2 + 1/2 x^3/b^3) Fb 1/EJ dx = [1/4 x^2/b - 1/3 x^3/b^2 + 1/8 x^4/b^3]_0^b Fb 1/EJ$$

$$= (1/4 b - 1/3 b + 1/8 b) Fb 1/EJ = 1/24 Fb^2/EJ$$

$$L_{EF}^{x_0} = \int_0^b (-1/2 x^2/b^2) Fb 1/EJ dx + \int_0^b (1) \theta dx = [-1/6 x^3/b^2]_0^b Fb 1/EJ + [x]_0^b \theta$$

$$= (-1/6 b) Fb 1/EJ + (b) \theta = 5/6 Fb^2/EJ$$

$$L_{FE}^{x_0} = \int_0^b (-1/2 + x/b - 1/2 x^2/b^2) Fb 1/EJ dx + \int_0^b (-1) \theta dx$$

$$= [-1/2 x + 1/2 x^2/b - 1/6 x^3/b^2]_0^b Fb 1/EJ + [-x]_0^b \theta$$

$$= (-1/2 b + 1/2 b - 1/6 b) Fb 1/EJ + (-b) \theta = 5/6 Fb^2/EJ$$

$$L_{FC}^{x_0} = \int_0^b (-1/2 + x/b - 1/2 x^2/b^2) Fb 1/EJ dx = [-1/2 x + 1/2 x^2/b - 1/6 x^3/b^2]_0^b Fb 1/EJ$$

$$= (-1/2 b + 1/2 b - 1/6 b) Fb 1/EJ = -1/6 Fb^2/EJ$$

$$L_{CF}^{x_0} = \int_0^b (-1/2 x^2/b^2) Fb 1/EJ dx = [-1/6 x^3/b^2]_0^b Fb 1/EJ$$

$$= (-1/6 b) Fb 1/EJ = -1/6 Fb^2/EJ$$

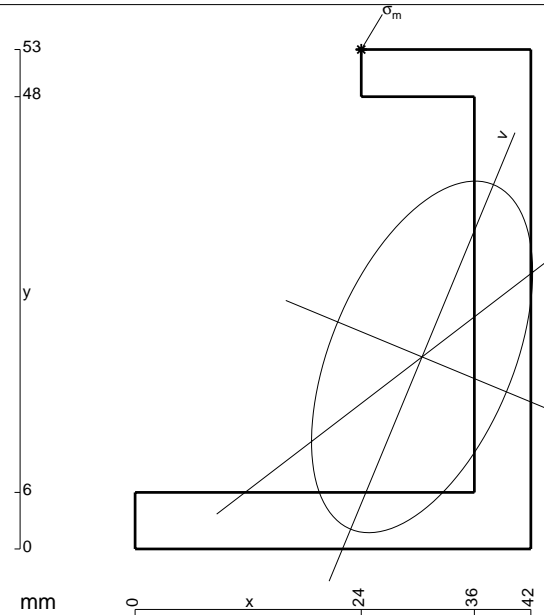

- A = 594. mm²
- J_x = 206801. mm⁴
- J_y = 81741. mm⁴
- J_{xy} = 62565. mm⁴
- J_u = 232726. mm⁴
- J_v = 55816. mm⁴
- α = arctg(2J_{xy}/(J_y-J_x))/2 = -.3928
- c = cos α = .9238
- s = sin α = -.3828
- x_g = 30.45 mm
- y_g = 20.38 mm
- N = -1789. N
- T_y = -894.4 N
- M_x = 960000. Nmm
- x_m = 24. mm
- y_m = 53. mm
- u_m = -18.45 mm
- v_m = 27.67 mm
- σ_m = N/A - Mc_v/J_u - Ms_u/J_v = -229.9 N/mm²

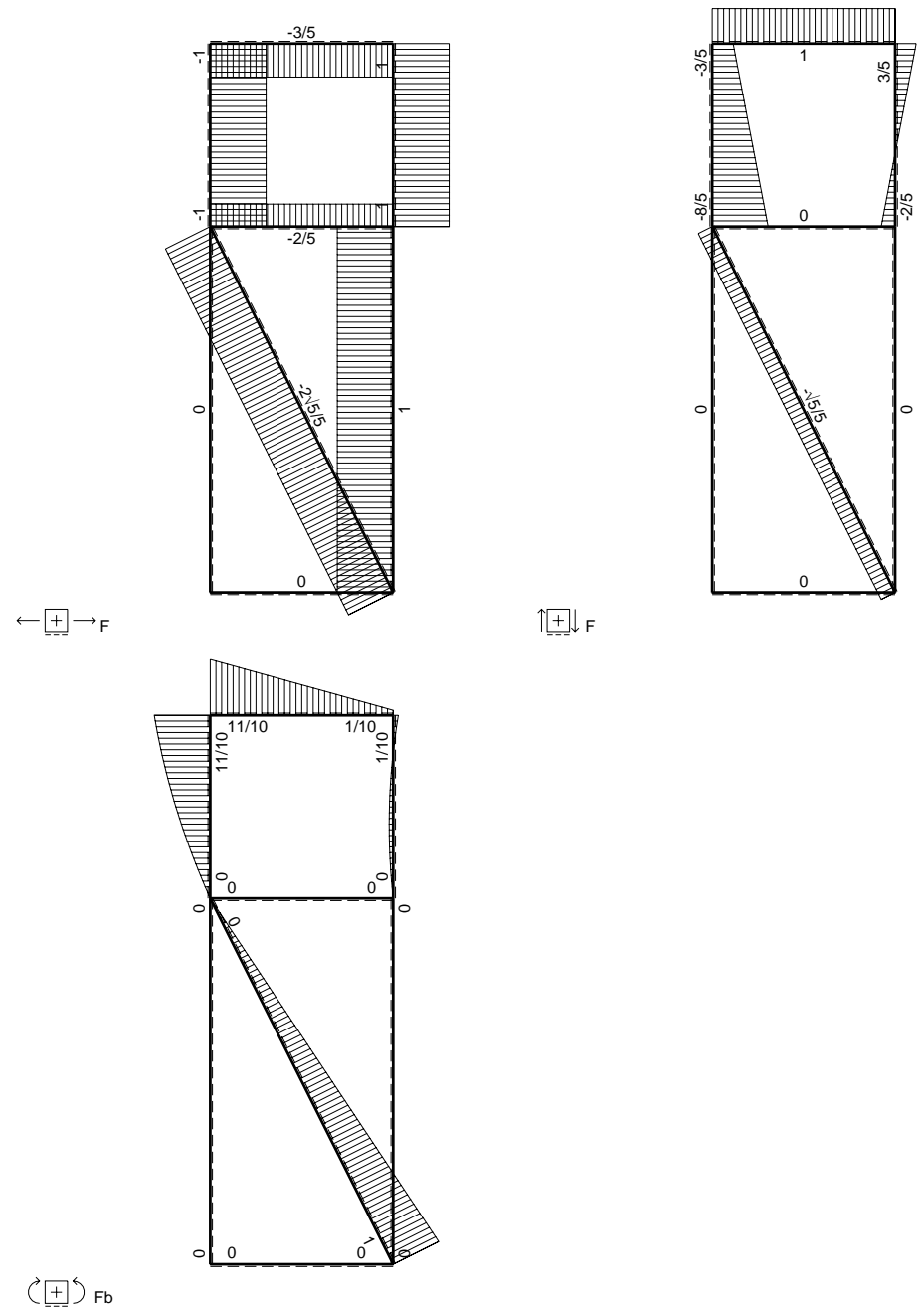
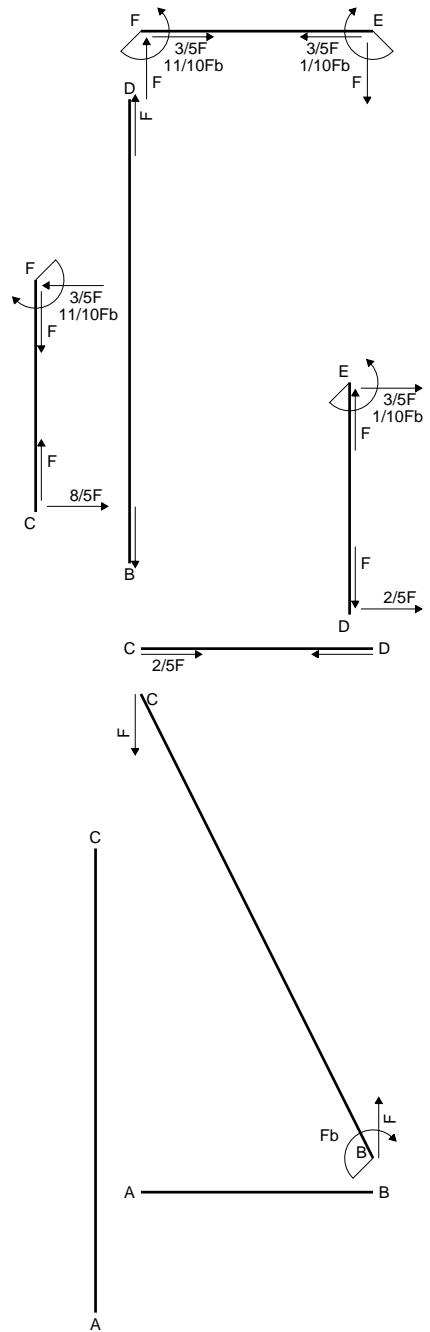

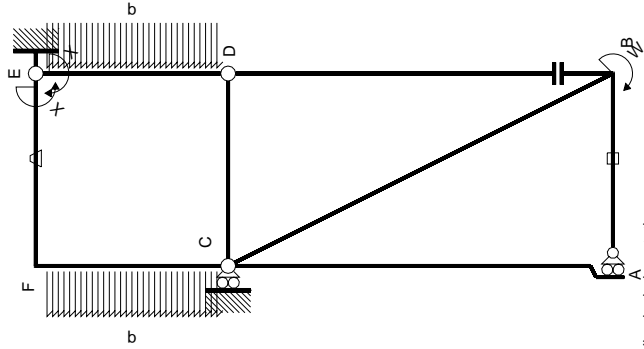

M_0 flessione da carichi assegnati

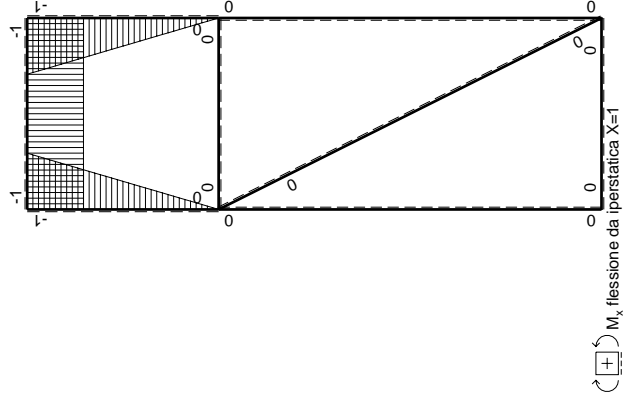

Quadro contributi PLV per iperstatica $X=W_{EF}$

\rightarrow	$M(x)$	$M_0(x)$	θ	$M_x M_0$	$M_x \theta$	$M_x M_x$	$\int M_x (M_0/EJ + \theta) dx$	$\int M_x M_x / EJ dx$
AB b	0	0	0	0	0	0	0+0	0
BA b	0	0	0	0	0	0	0	0
BC $\sqrt{5}b$	0	$Fb - \sqrt{5}/5Fx$	0	0	0	0	0+0	0
CA 2b	0	0	0	0	0	0	0+0	0
DB 2b	0	0	0	0	0	0	0+0	0
BD 2b	0	0	0	0	0	0	0+0	0
DE b	$-x/b$	$-1/2Fx + 1/2qx^2$	0	$1/2Fx^2/b - 1/2qx^3/b$	0	0	x^2/b^2	0
ED b	$1-x/b$	$1/2Fx - 1/2qx^2$	0	$1/2Fx - Fx^2/b + 1/2qx^3/b$	0	0	$1-2x/b+x^2/b^2$	$1/3xb/EJ$
CD b	0	0	0	0	0	0	0+0	0
FE b	-1	Fx	$-Fb/EJ$	-Fx	Fb/EJ	1	$(-1/2+1)Fb^2/EJ$	xb/EJ
FC b	$-1+x/b$	$-Fb - 1/2Fx - 1/2qx^2$	0	$-Fb + 3/2Fx - 1/2qx^3/b$	0	0	$1-2x/b+x^2/b^2$	$1/3xb/EJ$
CF b	x/b	$-3/2Fx + 1/2qx^2$	0	$-3/2Fx^2/b + 1/2qx^3/b$	0	0	x^2/b^2	$1/3xb/EJ$
totali								$5/3xb/EJ$
iperstatica $X=W_{EF}$								$-1/10Fb$

Sviluppi di calcolo iperstatica

$$L_{DE}^{xx} = \int_0^b (x^2/b^2) 1/EJ dx = [1/3 x^3/b^2]_0^b 1/EJ$$

$$= (1/3 b) 1/EJ = 1/3 b/EJ$$

$$L_{ED}^{xx} = \int_0^b (1 - 2x/b + x^2/b^2) 1/EJ dx = [x - x^2/b + 1/3 x^3/b^2]_0^b 1/EJ$$

$$= (b - b + 1/3 b) 1/EJ = 1/3 b/EJ$$

$$L_{EF}^{xx} = \int_0^b (1) 1/EJ dx = [x]_0^b 1/EJ$$

$$= (b) 1/EJ = b/EJ$$

$$L_{FE}^{xx} = \int_0^b (1) 1/EJ dx = [x]_0^b 1/EJ$$

$$= (b) 1/EJ = b/EJ$$

$$L_{FC}^{xx} = \int_0^b (1 - 2x/b + x^2/b^2) 1/EJ dx = [x - x^2/b + 1/3 x^3/b^2]_0^b 1/EJ$$

$$= (b - b + 1/3 b) 1/EJ = 1/3 b/EJ$$

$$L_{CF}^{xx} = \int_0^b (x^2/b^2) 1/EJ dx = [1/3 x^3/b^2]_0^b 1/EJ$$

$$= (1/3 b) 1/EJ = 1/3 b/EJ$$

$$L_{DE}^{xo} = \int_0^b (1/2 x^2/b^2 - 1/2 x^3/b^3) Fb 1/EJ dx = [1/6 x^3/b^2 - 1/8 x^4/b^3]_0^b Fb 1/EJ$$

$$= (1/6 b - 1/8 b) Fb 1/EJ = 1/24 Fb^2/EJ$$

$$L_{ED}^{xo} = \int_0^b (1/2 x/b - x^2/b^2 + 1/2 x^3/b^3) Fb 1/EJ dx = [1/4 x^2/b - 1/3 x^3/b^2 + 1/8 x^4/b^3]_0^b Fb 1/EJ$$

$$= (1/4 b - 1/3 b + 1/8 b) Fb 1/EJ = 1/24 Fb^2/EJ$$

$$L_{EF}^{xo} = \int_0^b (-x/b) Fb 1/EJ dx + \int_0^b (1) \theta dx = [-1/2 x^2/b]_0^b Fb 1/EJ + [x]_0^b \theta$$

$$= (-1/2 b) Fb 1/EJ + (b) \theta = 1/2 Fb^2/EJ$$

$$L_{FE}^{xo} = \int_0^b (-1 + x/b) Fb 1/EJ dx + \int_0^b (-1) \theta dx = [-x + 1/2 x^2/b]_0^b Fb 1/EJ + [-x]_0^b \theta$$

$$= (-b + 1/2 b) Fb 1/EJ + (-b) \theta = 1/2 Fb^2/EJ$$

$$L_{FC}^{xo} = \int_0^b (-1 + 3/2 x/b - 1/2 x^3/b^3) Fb 1/EJ dx = [-x + 3/4 x^2/b - 1/8 x^4/b^3]_0^b Fb 1/EJ$$

$$= (-b + 3/4 b - 1/8 b) Fb 1/EJ = -3/8 Fb^2/EJ$$

$$L_{CF}^{xo} = \int_0^b (-3/2 x^2/b^2 + 1/2 x^3/b^3) Fb 1/EJ dx = [-1/2 x^3/b^2 + 1/8 x^4/b^3]_0^b Fb 1/EJ$$

$$= (-1/2 b + 1/8 b) Fb 1/EJ = -3/8 Fb^2/EJ$$

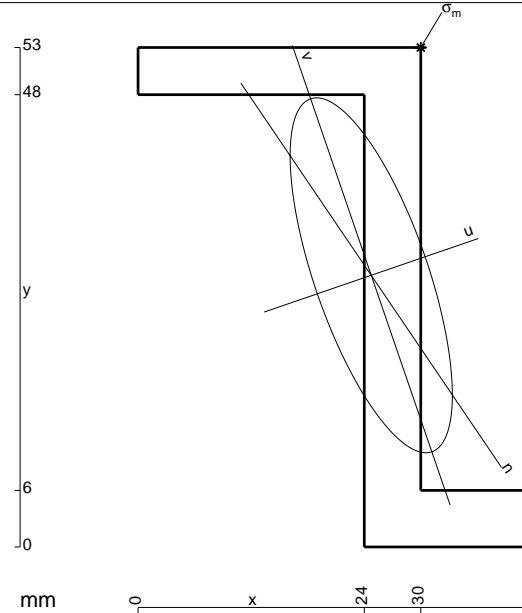

- A = 510. mm²
- J_x = 181019. mm⁴
- J_y = 37808. mm⁴
- J_{xy} = -55745. mm⁴
- J_u = 200159. mm⁴
- J_v = 18668. mm⁴
- α = arctg(2J_{xy}/(J_v-J_u))/2 = .3307
- c = cos α = .9458
- s = sin α = .3247
- x_g = 24.74 mm
- y_g = 28.83 mm
- N = -1310. N
- T_y = -786. N
- M_x = 734910. Nmm
- x_m = 30. mm
- y_m = 53. mm
- u_m = 12.82 mm
- v_m = 21.15 mm
- σ_m = N/A - Mc_v/J_u - Ms_u/J_v = -240. N/mm²

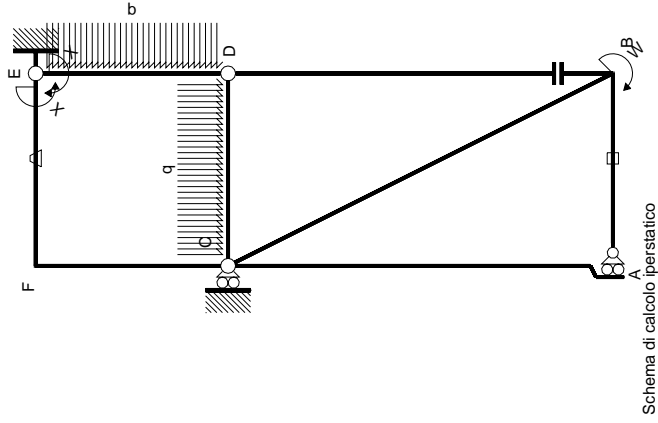

M_0 flessione da carichi assegnati

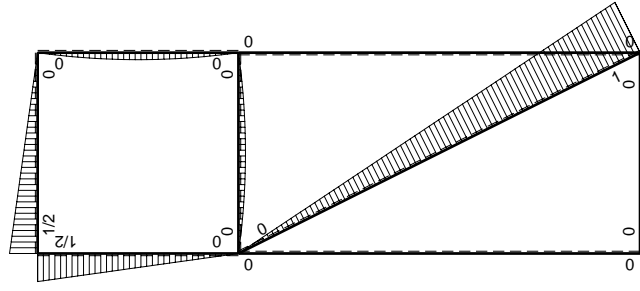

M_x flessione da iperstatica $X=1$

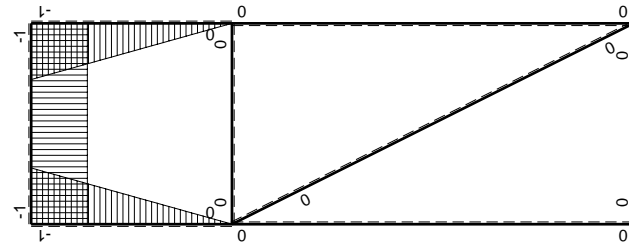

Quadro contributi PLV per iperstatica $X=W_{EF}$

\leftarrow	$M^x(x)$	$M^0(x)$	θ	$M^x M_0$	$M^x \theta$	$M^x M_x$	$\int M^x (M_0/EJ + \theta) dx$	$\int M^x M_x / EJ dx$
AB b	0	0	0	0	0	0	0+0	0
BA b	0	0	0	0	0	0	0	0
BC $\sqrt{5}b$	0	$Fb\sqrt{5}/5Fx$	0	0	0	0	0+0	0
CA 2b	0	0	0	0	0	0	0+0	0
DB 2b	0	0	0	0	0	0	0+0	0
BD 2b	0	0	0	0	0	0	0+0	0
DE b	$-x/b$	$-1/2Fx + 1/2qx^2$	0	$1/2Fx^2/b - 1/2qx^3/b$	0	0	x^2/b^2	$1/3Xb/EJ$
ED b	$1-x/b$	$1/2Fx - 1/2qx^2$	0	$1/2Fx - Fx^2/b + 1/2qx^3/b$	0	0	$1-2x/b+x^2/b^2$	$1/3Xb/EJ$
CD b	0	$1/2Fx - 1/2qx^2$	0	0	0	0	0	0
DC b	0	$-1/2Fx + 1/2qx^2$	0	0	0	0	0+0	0
EF b	-1	$1/2Fx$	$-Fb/EJ$	$-1/2Fx$	Fb/EJ	1	$(-1/4+1)Fb^2/EJ$	Xb/EJ
FE b	1	$-1/2Fb + 1/2Fx$	Fb/EJ	$-1/2Fb + 1/2Fx$	Fb/EJ	1	$(-1/4+1)Fb^2/EJ$	Xb/EJ
FC b	$-1+x/b$	$1/2Fb - 1/2Fx$	0	$-1/2Fb + Fx - 1/2Fx^2/b$	0	0	$1-2x/b+x^2/b^2$	$1/3Xb/EJ$
CF b	x/b	$-1/2Fx$	0	$-1/2Fx^2/b$	0	0	x^2/b^2	$1/3Xb/EJ$
totali								$5/8Fb^2/EJ$
								$-3/8Fb$

Sviluppi di calcolo iperstatica

$$L_{DE}^{xx} = \int_0^b (x^2/b^2) 1/EJ dx = [1/3 x^3/b^2]_0^b 1/EJ$$

$$= (1/3 b) 1/EJ = 1/3 b/EJ$$

$$L_{ED}^{xx} = \int_0^b (1 - 2x/b + x^2/b^2) 1/EJ dx = [x - x^2/b + 1/3 x^3/b^2]_0^b 1/EJ$$

$$= (b - b + 1/3 b) 1/EJ = 1/3 b/EJ$$

$$L_{EF}^{xx} = \int_0^b (1) 1/EJ dx = [x]_0^b 1/EJ$$

$$= (b) 1/EJ = b/EJ$$

$$L_{FE}^{xx} = \int_0^b (1) 1/EJ dx = [x]_0^b 1/EJ$$

$$= (b) 1/EJ = b/EJ$$

$$L_{FC}^{xx} = \int_0^b (1 - 2x/b + x^2/b^2) 1/EJ dx = [x - x^2/b + 1/3 x^3/b^2]_0^b 1/EJ$$

$$= (b - b + 1/3 b) 1/EJ = 1/3 b/EJ$$

$$L_{CF}^{xx} = \int_0^b (x^2/b^2) 1/EJ dx = [1/3 x^3/b^2]_0^b 1/EJ$$

$$= (1/3 b) 1/EJ = 1/3 b/EJ$$

$$L_{DE}^{xo} = \int_0^b (1/2 x^2/b^2 - 1/2 x^3/b^3) Fb 1/EJ dx = [1/6 x^3/b^2 - 1/8 x^4/b^3]_0^b Fb 1/EJ$$

$$= (1/6 b - 1/8 b) Fb 1/EJ = 1/24 Fb^2/EJ$$

$$L_{ED}^{xo} = \int_0^b (1/2 x/b - x^2/b^2 + 1/2 x^3/b^3) Fb 1/EJ dx = [1/4 x^2/b - 1/3 x^3/b^2 + 1/8 x^4/b^3]_0^b Fb 1/EJ$$

$$= (1/4 b - 1/3 b + 1/8 b) Fb 1/EJ = 1/24 Fb^2/EJ$$

$$L_{EF}^{xo} = \int_0^b (-1/2 x/b) Fb 1/EJ dx + \int_0^b (1) \theta dx = [-1/4 x^2/b]_0^b Fb 1/EJ + [x]_0^b \theta$$

$$= (-1/4 b) Fb 1/EJ + (b) \theta = 3/4 Fb^2/EJ$$

$$L_{FE}^{xo} = \int_0^b (-1/2 + 1/2 x/b) Fb 1/EJ dx + \int_0^b (-1) \theta dx = [-1/2 x + 1/4 x^2/b]_0^b Fb 1/EJ + [-x]_0^b \theta$$

$$= (-1/2 b + 1/4 b) Fb 1/EJ + (-b) \theta = 3/4 Fb^2/EJ$$

$$L_{FC}^{xo} = \int_0^b (-1/2 + x/b - 1/2 x^2/b^2) Fb 1/EJ dx = [-1/2 x + 1/2 x^2/b - 1/6 x^3/b^2]_0^b Fb 1/EJ$$

$$= (-1/2 b + 1/2 b - 1/6 b) Fb 1/EJ = -1/6 Fb^2/EJ$$

$$L_{CF}^{xo} = \int_0^b (-1/2 x^2/b^2) Fb 1/EJ dx = [-1/6 x^3/b^2]_0^b Fb 1/EJ$$

$$= (-1/6 b) Fb 1/EJ = -1/6 Fb^2/EJ$$

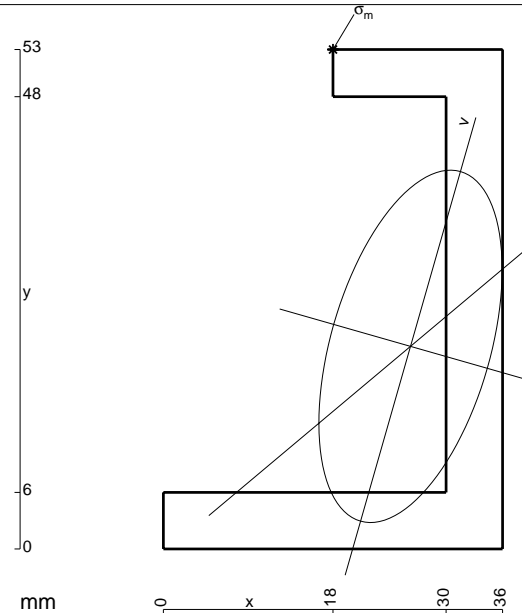

- A = 558. mm²
- J_x = 195119. mm⁴
- J_y = 52748. mm⁴
- J_{xy} = 44280. mm⁴
- J_u = 207767. mm⁴
- J_v = 40099. mm⁴
- α = arctg(2J_{xy}/(J_y-J_x))/2 = -.2782
- c = cos α = .9615
- s = sin α = -.2747
- x_g = 26.23 mm
- y_g = 21.5 mm
- N = -1315. N
- T_y = -657.4 N
- M_x = 808500. Nmm
- x_m = 18. mm
- y_m = 53. mm
- u_m = -16.56 mm
- v_m = 28.03 mm
- σ_m = N/A - Mc_v/J_u - Ms_u/J_v = -198.9 N/mm²

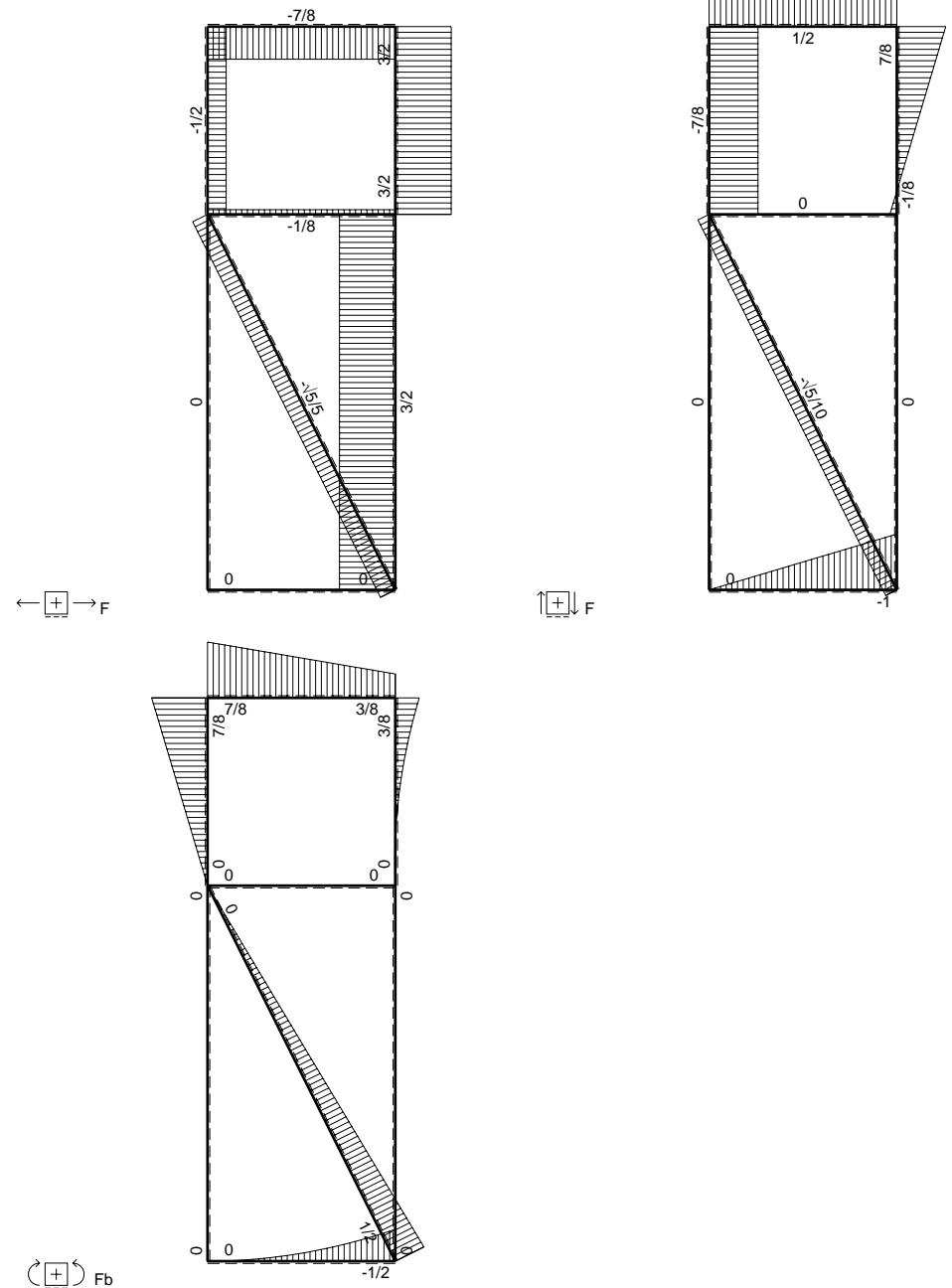
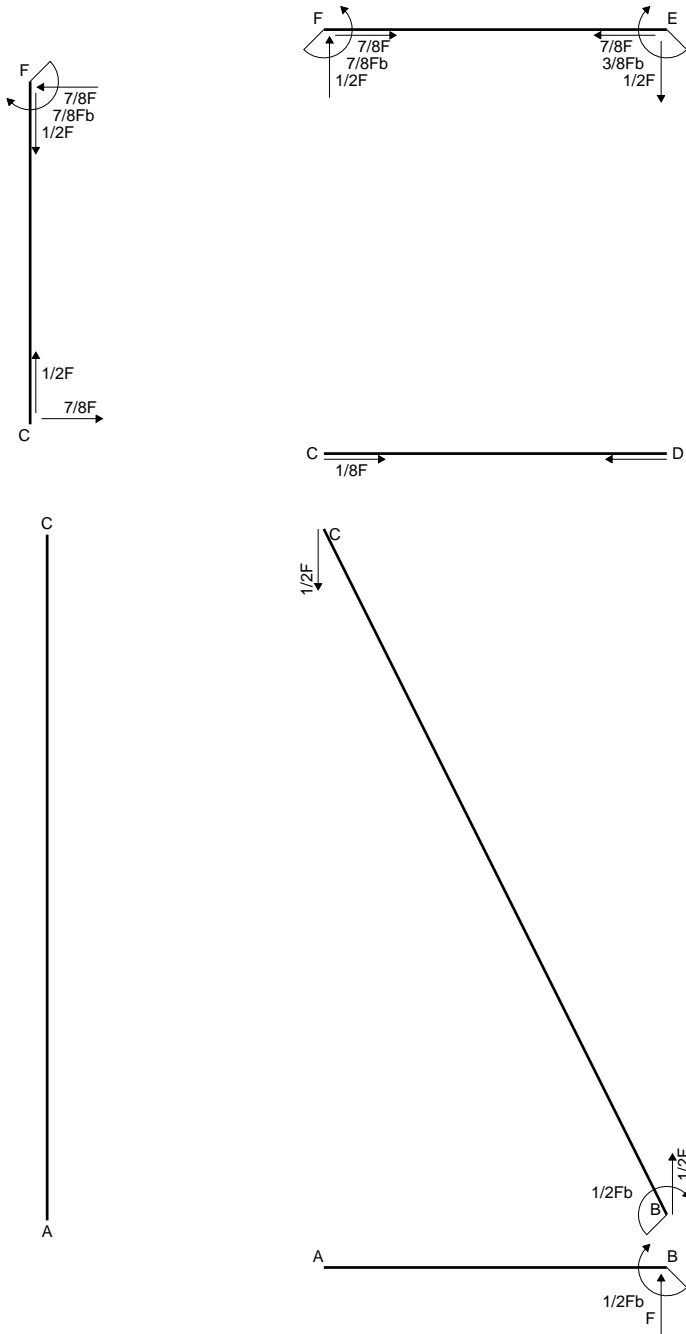

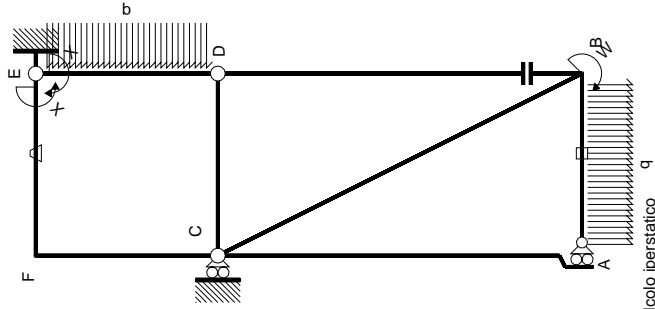

Schema di calcolo iperstatico

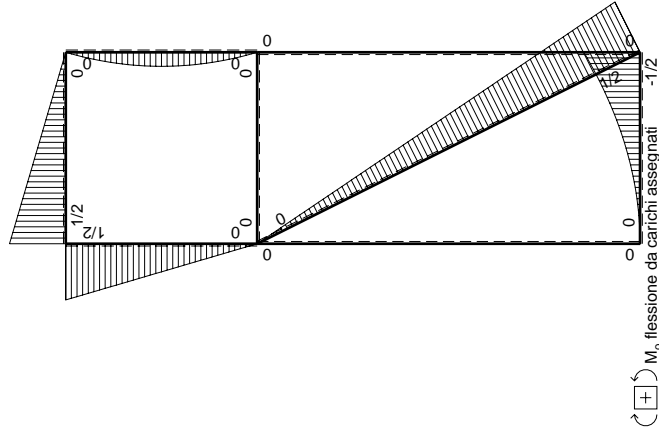

M_0 flessione da carichi assegnati

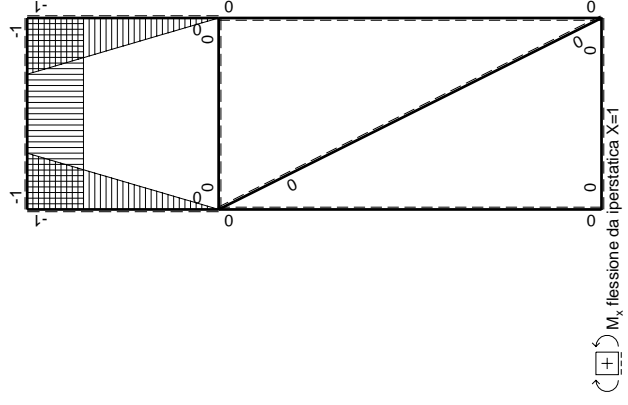

M_x flessione da iperstatica X=1

Quadro contribuiti PLV per iperstatica X=W^{EF}

←	M ₀ (x)	M ₀ (x)	θ	M ₀ M ₀	M ₀ θ	M ₀ M _x	∫M ₀ (M ₀ /EJ+θ)dx	∫M ₀ M _x /EJdx
AB B	0	-1/2qx ²	0	0	0	0	0+0	0
BA B	0	1/2Fb-Fx+1/2qx ²	0	0	0	0	0	0
BC √5b	0	1/2Fb-√5/10Fx	0	0	0	0	0+0	0
CA 2b	0	0	0	0	0	0	0+0	0
DB 2b	0	0	0	0	0	0	0+0	0
BD 2b	0	0	0	0	0	0	0+0	0
DE b	-x/b	-1/2Fx+1/2qx ²	0	1/2F ² x ² /b-1/2qx ³ /b	0	x ² /b ²	(1/2+0)F ² /EJ	1/3Xb/EJ
ED b	1-x/b	1/2Fx-1/2qx ²	0	1/2Fx-Fx ² /b+1/2qx ³ /b	0	1-2x/b+x ² /b ²	(1/2+0)F ² /EJ	1/3Xb/EJ
CD b	0	0	0	0	0	0	0+0	0
DC b	0	0	0	0	0	0	0+0	0
EF b	-1	1/2Fx	-Fb/EJ	-1/2Fx	Fb/EJ	1	(-1/4+1)F ² /EJ	Xb/EJ
FE b	1	-1/2Fb+1/2Fx	Fb/EJ	-1/2Fb+1/2Fx	Fb/EJ	1	(-1/4+1)F ² /EJ	Xb/EJ
FC b	-1+x/b	1/2Fb-1/2Fx	0	-1/2Fb+Fx-1/2Fx ² /b	0	1-2x/b+x ² /b ²	(-1/6+0)F ² /EJ	1/3Xb/EJ
CF b	x/b	-1/2Fx	0	-1/2Fx ² /b	0	x ² /b ²	(-1/6+0)F ² /EJ	1/3Xb/EJ
totali							5/8F ² /EJ	5/3Xb/EJ
								-3/8Fb

iperstatica X=W^{EF}

Sviluppi di calcolo iperstatica

$$L_{DE}^{xx} = \int_0^b (x^2/b^2) 1/EJ dx = [1/3 x^3/b^2]_0^b 1/EJ$$

$$= (1/3 b) 1/EJ = 1/3 b/EJ$$

$$L_{ED}^{xx} = \int_0^b (1 - 2x/b + x^2/b^2) 1/EJ dx = [x - x^2/b + 1/3 x^3/b^2]_0^b 1/EJ$$

$$= (b - b + 1/3 b) 1/EJ = 1/3 b/EJ$$

$$L_{EF}^{xx} = \int_0^b (1) 1/EJ dx = [x]_0^b 1/EJ$$

$$= (b) 1/EJ = b/EJ$$

$$L_{FE}^{xx} = \int_0^b (1) 1/EJ dx = [x]_0^b 1/EJ$$

$$= (b) 1/EJ = b/EJ$$

$$L_{FC}^{xx} = \int_0^b (1 - 2x/b + x^2/b^2) 1/EJ dx = [x - x^2/b + 1/3 x^3/b^2]_0^b 1/EJ$$

$$= (b - b + 1/3 b) 1/EJ = 1/3 b/EJ$$

$$L_{CF}^{xx} = \int_0^b (x^2/b^2) 1/EJ dx = [1/3 x^3/b^2]_0^b 1/EJ$$

$$= (1/3 b) 1/EJ = 1/3 b/EJ$$

$$L_{DE}^{xo} = \int_0^b (1/2 x^2/b^2 - 1/2 x^3/b^3) Fb 1/EJ dx = [1/6 x^3/b^2 - 1/8 x^4/b^3]_0^b Fb 1/EJ$$

$$= (1/6 b - 1/8 b) Fb 1/EJ = 1/24 Fb^2/EJ$$

$$L_{ED}^{xo} = \int_0^b (1/2 x/b - x^2/b^2 + 1/2 x^3/b^3) Fb 1/EJ dx = [1/4 x^2/b - 1/3 x^3/b^2 + 1/8 x^4/b^3]_0^b Fb 1/EJ$$

$$= (1/4 b - 1/3 b + 1/8 b) Fb 1/EJ = 1/24 Fb^2/EJ$$

$$L_{EF}^{xo} = \int_0^b (-1/2 x/b) Fb 1/EJ dx + \int_0^b (1) \theta dx = [-1/4 x^2/b]_0^b Fb 1/EJ + [x]_0^b \theta$$

$$= (-1/4 b) Fb 1/EJ + (b) \theta = 3/4 Fb^2/EJ$$

$$L_{FE}^{xo} = \int_0^b (-1/2 + 1/2 x/b) Fb 1/EJ dx + \int_0^b (-1) \theta dx = [-1/2 x + 1/4 x^2/b]_0^b Fb 1/EJ + [-x]_0^b \theta$$

$$= (-1/2 b + 1/4 b) Fb 1/EJ + (-b) \theta = 3/4 Fb^2/EJ$$

$$L_{FC}^{xo} = \int_0^b (-1/2 + x/b - 1/2 x^2/b^2) Fb 1/EJ dx = [-1/2 x + 1/2 x^2/b - 1/6 x^3/b^2]_0^b Fb 1/EJ$$

$$= (-1/2 b + 1/2 b - 1/6 b) Fb 1/EJ = -1/6 Fb^2/EJ$$

$$L_{CF}^{xo} = \int_0^b (-1/2 x^2/b^2) Fb 1/EJ dx = [-1/6 x^3/b^2]_0^b Fb 1/EJ$$

$$= (-1/6 b) Fb 1/EJ = -1/6 Fb^2/EJ$$

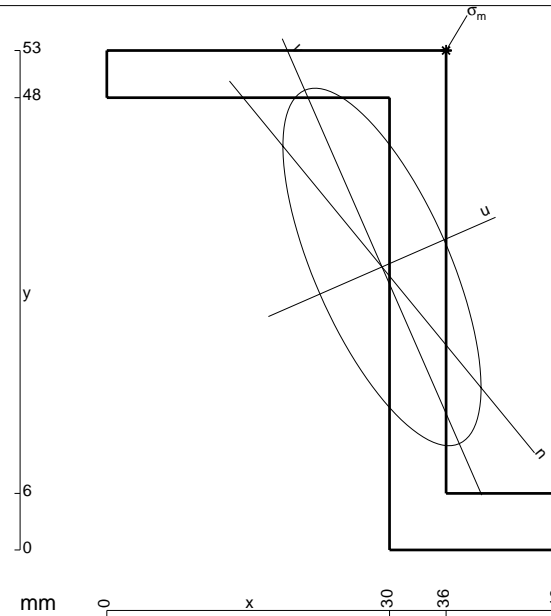

- A = 540. mm²
- J_x = 194387. mm⁴
- J_y = 59702. mm⁴
- J_{xy} = -72778. mm⁴
- J_u = 226199. mm⁴
- J_v = 27891. mm⁴
- α = arctg(2J_{xy}/(J_y-J_x))/2 = .4121
- c = cos α = .9163
- s = sin α = .4005
- x_g = 29.2 mm
- y_g = 30.03 mm
- N = -1190. N
- T_y = 680. N
- M_x = 702100. Nmm
- x_m = 36. mm
- y_m = 53. mm
- u_m = 15.43 mm
- v_m = 18.32 mm
- σ_m = N/A - Mcv/J_u - Msu/J_v = -209.9 N/mm²

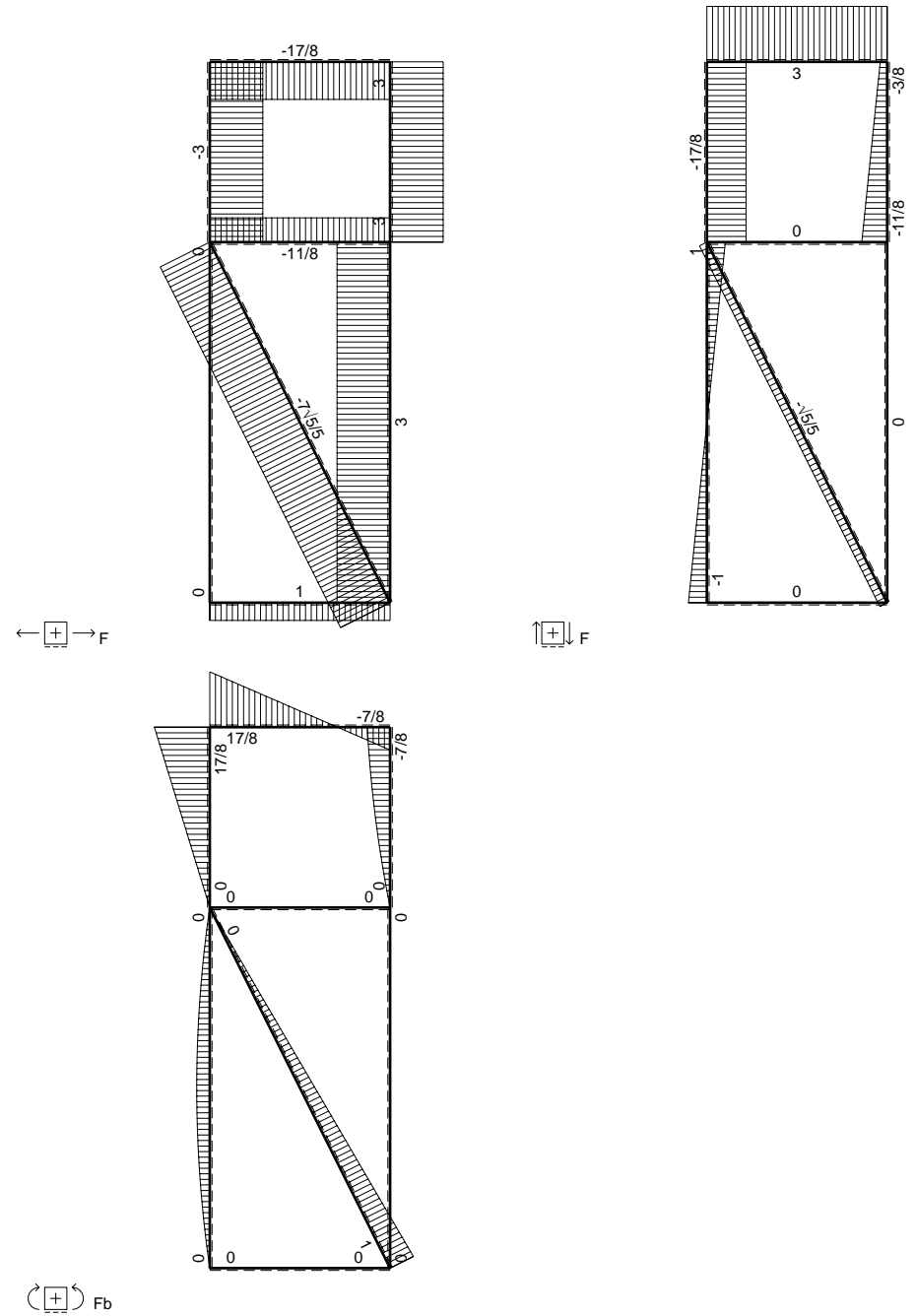
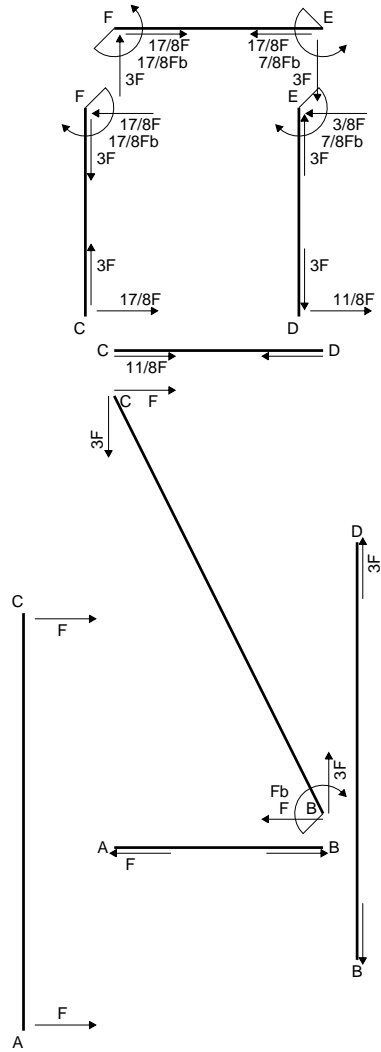

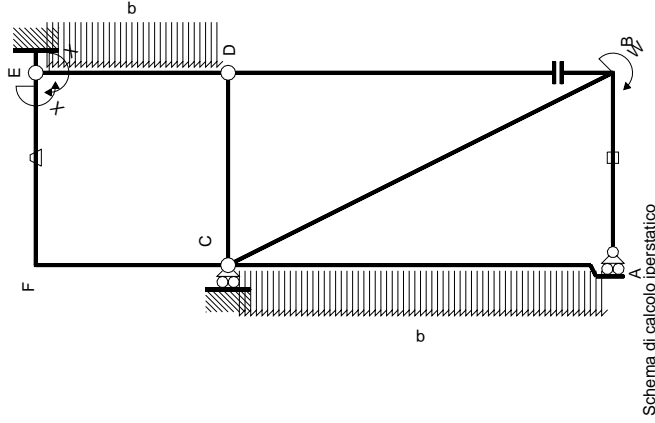

M_0 flessione da carichi assegnati

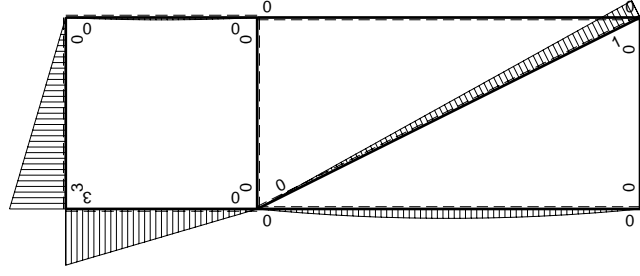

Quadro contributi PLV per iperstatica $X=W_{EF}$

\leftarrow	$M^x(x)$	$M^0(x)$	θ	$M^x M_0$	$M^x \theta$	$M^x M_x$	$\int M^x(M_0/EJ+\theta)dx$	$\int M^x M_x/EJdx$
AB b	0	0	0	0	0	0	0+0	0
BA b	0	0	0	0	0	0	0	0
BC $\sqrt{5}b$	0	$Fb-\sqrt{5}/5Fx$	0	0	0	0	0	0
AC 2b	0	$-Fx+1/2qx^2$	0	0	0	0	0+0	0
CA 2b	0	$Fx-1/2qx^2$	0	0	0	0	0	0
DB 2b	0	0	0	0	0	0	0+0	0
BD 2b	0	0	0	0	0	0	0	0
DE b	$-x/b$	$-1/2Fx+1/2qx^2$	0	$1/2Fx^2/b-1/2qx^3/b$	0	0	x^2/b^2	$1/3Xb/EJ$
ED b	$1-x/b$	$1/2Fx-1/2qx^2$	0	$1/2Fx-Fx^2/b+1/2qx^3/b$	0	0	$1-2x/b+x^2/b^2$	$1/3Xb/EJ$
CD b	0	0	0	0	0	0	0+0	0
DC b	0	0	0	0	0	0	0	0
EF b	-1	$3Fx$	$-Fb/EJ$	$-3Fx$	Fb/EJ	1	$(-3/2+1)Fb^2/EJ$	Xb/EJ
FE b	1	$-3Fb+3Fx$	Fb/EJ	$-3Fb+3Fx$	Fb/EJ	1	$(-3/2+1)Fb^2/EJ$	Xb/EJ
FC b	$-1+x/b$	$3Fb-3Fx$	0	$-3Fb+6Fx-3Fx^2/b$	0	0	$1-2x/b+x^2/b^2$	$(-1+0)Fb^2/EJ$
CF b	x/b	$-3Fx$	0	$-3Fx^2/b$	0	0	x^2/b^2	$1/3Xb/EJ$
totali								$5/3Xb/EJ$
								$7/8Fb$

Sviluppi di calcolo iperstatica

M_x flessione da iperstatica $X=1$

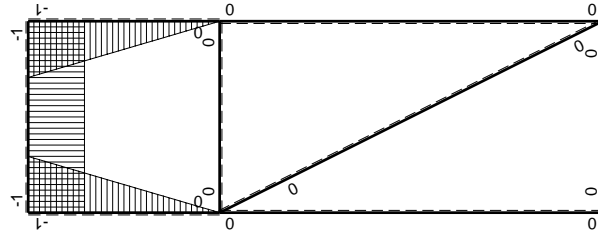

$$L_{DE}^{xx} = \int_0^b (x^2/b^2) 1/EJ dx = [1/3 x^3/b^2]_0^b 1/EJ$$

$$= (1/3 b) 1/EJ = 1/3 b/EJ$$

$$L_{ED}^{xx} = \int_0^b (1 - 2x/b + x^2/b^2) 1/EJ dx = [x - x^2/b + 1/3 x^3/b^2]_0^b 1/EJ$$

$$= (b - b + 1/3 b) 1/EJ = 1/3 b/EJ$$

$$L_{EF}^{xx} = \int_0^b (1) 1/EJ dx = [x]_0^b 1/EJ$$

$$= (b) 1/EJ = b/EJ$$

$$L_{FE}^{xx} = \int_0^b (1) 1/EJ dx = [x]_0^b 1/EJ$$

$$= (b) 1/EJ = b/EJ$$

$$L_{FC}^{xx} = \int_0^b (1 - 2x/b + x^2/b^2) 1/EJ dx = [x - x^2/b + 1/3 x^3/b^2]_0^b 1/EJ$$

$$= (b - b + 1/3 b) 1/EJ = 1/3 b/EJ$$

$$L_{CF}^{xx} = \int_0^b (x^2/b^2) 1/EJ dx = [1/3 x^3/b^2]_0^b 1/EJ$$

$$= (1/3 b) 1/EJ = 1/3 b/EJ$$

$$L_{DE}^{xo} = \int_0^b (1/2 x^2/b^2 - 1/2 x^3/b^3) Fb 1/EJ dx = [1/6 x^3/b^2 - 1/8 x^4/b^3]_0^b Fb 1/EJ$$

$$= (1/6 b - 1/8 b) Fb 1/EJ = 1/24 Fb^2/EJ$$

$$L_{ED}^{xo} = \int_0^b (1/2 x/b - x^2/b^2 + 1/2 x^3/b^3) Fb 1/EJ dx = [1/4 x^2/b - 1/3 x^3/b^2 + 1/8 x^4/b^3]_0^b Fb 1/EJ$$

$$= (1/4 b - 1/3 b + 1/8 b) Fb 1/EJ = 1/24 Fb^2/EJ$$

$$L_{EF}^{xo} = \int_0^b (-3x/b) Fb 1/EJ dx + \int_0^b (1) \theta dx = [-3/2 x^2/b]_0^b Fb 1/EJ + [x]_0^b \theta$$

$$= (-3/2 b) Fb 1/EJ + (b) \theta = -1/2 Fb^2/EJ$$

$$L_{FE}^{xo} = \int_0^b (-3 + 3x/b) Fb 1/EJ dx + \int_0^b (-1) \theta dx = [-3x + 3/2 x^2/b]_0^b Fb 1/EJ + [-x]_0^b \theta$$

$$= (-3b + 3/2 b) Fb 1/EJ + (-b) \theta = -1/2 Fb^2/EJ$$

$$L_{FC}^{xo} = \int_0^b (-3 + 6x/b - 3x^2/b^2) Fb 1/EJ dx = [-3x + 3x^2/b - x^3/b^2]_0^b Fb 1/EJ$$

$$= (-3b + 3b - b) Fb 1/EJ = - Fb^2/EJ$$

$$L_{CF}^{xo} = \int_0^b (-3x^2/b^2) Fb 1/EJ dx = [-x^3/b^2]_0^b Fb 1/EJ$$

$$= (-b) Fb 1/EJ = - Fb^2/EJ$$

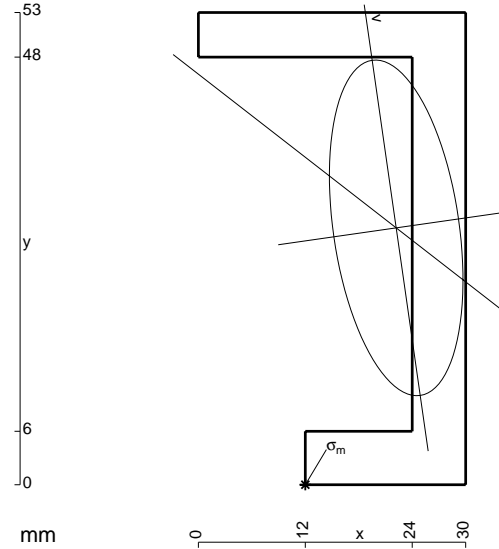

- A = 510. mm²
- J_x = 181019. mm⁴
- J_y = 28660. mm⁴
- J_{xy} = -22270. mm⁴
- J_u = 184207. mm⁴
- J_v = 25471. mm⁴
- α = arctg(2J_{xy}/(J_y-J_x))/2 = .1422
- c = cos α = .9899
- s = sin α = .1417
- x_g = 22.2 mm
- y_g = 28.83 mm
- N = -1594. N
- T_g = 2250. N
- M_x = 988125. Nmm
- x_m = 12. mm
- u_m = -14.18 mm
- v_m = -27.09 mm
- σ_m = N/A - Mcv/J_v - Msu/J_u = 218.7 N/mm²

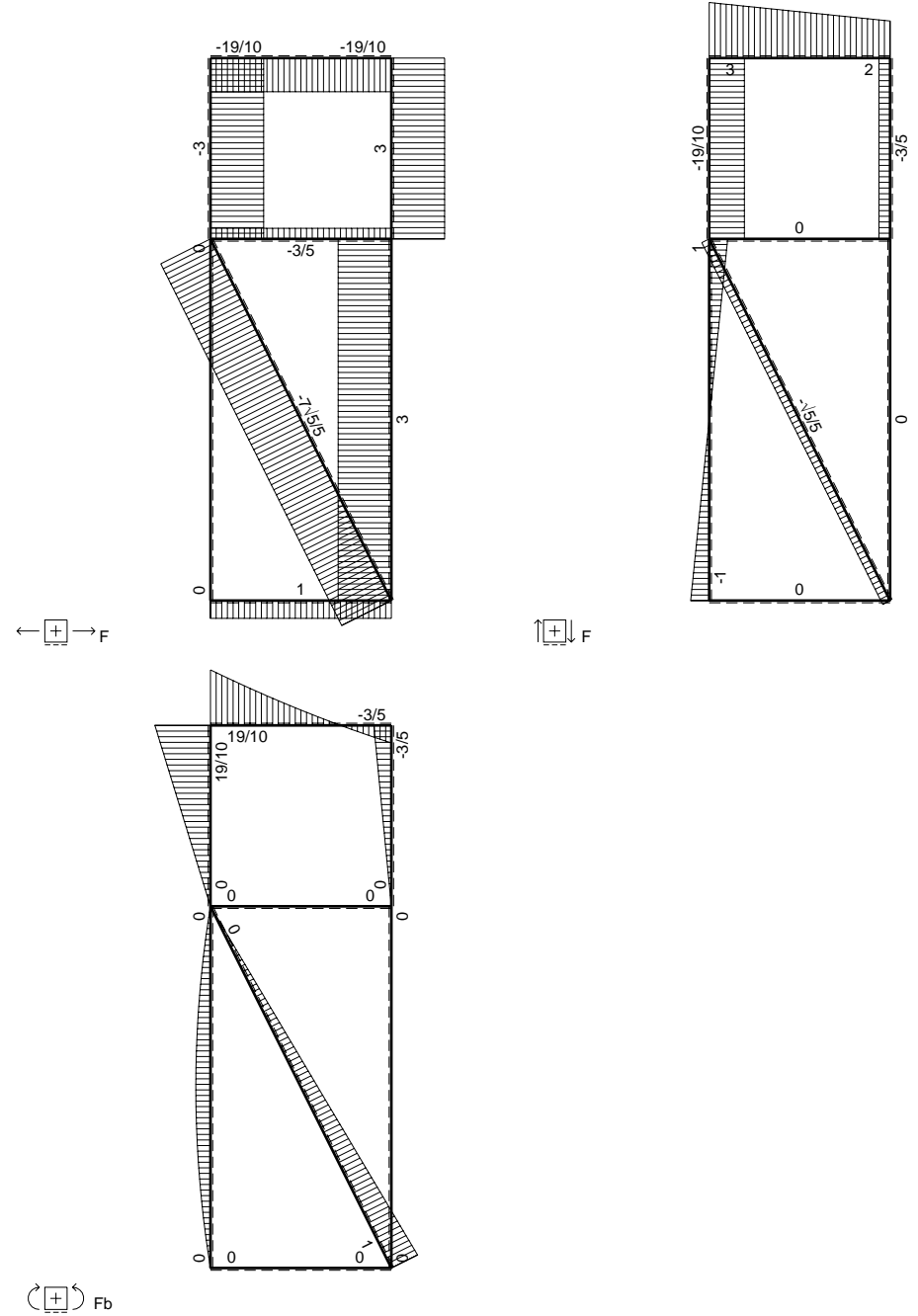
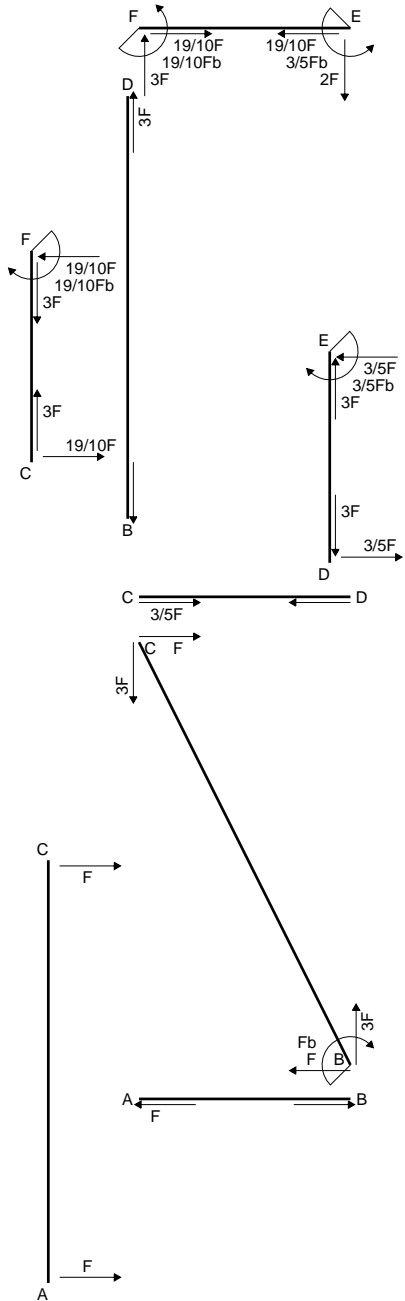

$$L_{DE}^{xx} = \int_0^b (x^2/b^2) 1/EJ dx = [1/3 x^3/b^2]_0^b 1/EJ$$

$$= (1/3 b) 1/EJ = 1/3 b/EJ$$

$$L_{ED}^{xx} = \int_0^b (1 - 2x/b + x^2/b^2) 1/EJ dx = [x - x^2/b + 1/3 x^3/b^2]_0^b 1/EJ$$

$$= (b - b + 1/3 b) 1/EJ = 1/3 b/EJ$$

$$L_{EF}^{xx} = \int_0^b (1) 1/EJ dx = [x]_0^b 1/EJ$$

$$= (b) 1/EJ = b/EJ$$

$$L_{FE}^{xx} = \int_0^b (1) 1/EJ dx = [x]_0^b 1/EJ$$

$$= (b) 1/EJ = b/EJ$$

$$L_{FC}^{xx} = \int_0^b (1 - 2x/b + x^2/b^2) 1/EJ dx = [x - x^2/b + 1/3 x^3/b^2]_0^b 1/EJ$$

$$= (b - b + 1/3 b) 1/EJ = 1/3 b/EJ$$

$$L_{CF}^{xx} = \int_0^b (x^2/b^2) 1/EJ dx = [1/3 x^3/b^2]_0^b 1/EJ$$

$$= (1/3 b) 1/EJ = 1/3 b/EJ$$

$$L_{EF}^{x\theta} = \int_0^b (-2x/b - 1/2 x^2/b^2) Fb 1/EJ dx + \int_0^b (1) \theta dx = [-x^2/b - 1/6 x^3/b^2]_0^b Fb 1/EJ + [x]_0^b \theta$$

$$= (-b - 1/6 b) Fb 1/EJ + (b) \theta = -1/6 Fb^2/EJ$$

$$L_{FE}^{x\theta} = \int_0^b (-5/2 + 3x/b - 1/2 x^2/b^2) Fb 1/EJ dx + \int_0^b (-1) \theta dx$$

$$= [-5/2 x + 3/2 x^2/b - 1/6 x^3/b^2]_0^b Fb 1/EJ + [-x]_0^b \theta$$

$$= (-5/2 b + 3/2 b - 1/6 b) Fb 1/EJ + (-b) \theta = -1/6 Fb^2/EJ$$

$$L_{FC}^{x\theta} = \int_0^b (-5/2 + 5x/b - 5/2 x^2/b^2) Fb 1/EJ dx = [-5/2 x + 5/2 x^2/b - 5/6 x^3/b^2]_0^b Fb 1/EJ$$

$$= (-5/2 b + 5/2 b - 5/6 b) Fb 1/EJ = -5/6 Fb^2/EJ$$

$$L_{CF}^{x\theta} = \int_0^b (-5/2 x^2/b^2) Fb 1/EJ dx = [-5/6 x^3/b^2]_0^b Fb 1/EJ$$

$$= (-5/6 b) Fb 1/EJ = -5/6 Fb^2/EJ$$

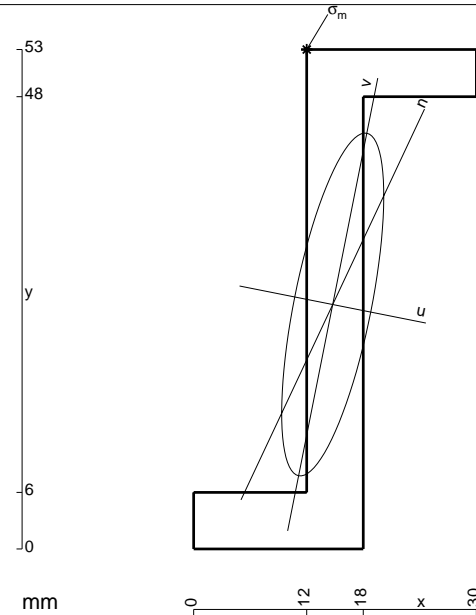

$$A = 450. \text{ mm}^2$$

$$J_x = 148960. \text{ mm}^4$$

$$J_y = 13204. \text{ mm}^4$$

$$J_{xy} = 28128. \text{ mm}^4$$

$$J_u = 154557. \text{ mm}^4$$

$$J_v = 7607. \text{ mm}^4$$

$$\alpha = \text{artg}(2J_{xy}/(J_y - J_x))/2 = -.1964$$

$$c = \cos \alpha = .9808$$

$$s = \sin \alpha = -.1952$$

$$x_g = 14.76 \text{ mm}$$

$$y_g = 25.94 \text{ mm}$$

$$N = -1440. \text{ N}$$

$$T_y = -912. \text{ N}$$

$$M_x = 601920. \text{ Nmm}$$

$$x_m = 12. \text{ mm}$$

$$y_m = 53. \text{ mm}$$

$$u_m = -7.988 \text{ mm}$$

$$v_m = 26. \text{ mm}$$

$$\sigma_m = N/A - Mcv/J_u - Msu/J_v = -225.9 \text{ N/mm}^2$$

$$L_{DE}^{xx} = \int_0^b (x^2/b^2) 1/EJ dx = [1/3 x^3/b^2]_0^b 1/EJ$$

$$= (1/3 b) 1/EJ = 1/3 b/EJ$$

$$L_{ED}^{xx} = \int_0^b (1 - 2x/b + x^2/b^2) 1/EJ dx = [x - x^2/b + 1/3 x^3/b^2]_0^b 1/EJ$$

$$= (b - b + 1/3 b) 1/EJ = 1/3 b/EJ$$

$$L_{EF}^{xx} = \int_0^b (1) 1/EJ dx = [x]_0^b 1/EJ$$

$$= (b) 1/EJ = b/EJ$$

$$L_{FE}^{xx} = \int_0^b (1) 1/EJ dx = [x]_0^b 1/EJ$$

$$= (b) 1/EJ = b/EJ$$

$$L_{FC}^{xx} = \int_0^b (1 - 2x/b + x^2/b^2) 1/EJ dx = [x - x^2/b + 1/3 x^3/b^2]_0^b 1/EJ$$

$$= (b - b + 1/3 b) 1/EJ = 1/3 b/EJ$$

$$L_{CF}^{xx} = \int_0^b (x^2/b^2) 1/EJ dx = [1/3 x^3/b^2]_0^b 1/EJ$$

$$= (1/3 b) 1/EJ = 1/3 b/EJ$$

$$L_{EF}^{xo} = \int_0^b (-5/2 x/b) Fb 1/EJ dx + \int_0^b (1) \theta dx = [-5/4 x^2/b]_0^b Fb 1/EJ + [x]_0^b \theta$$

$$= (-5/4 b) Fb 1/EJ + (b) \theta = -1/4 Fb^2/EJ$$

$$L_{FE}^{xo} = \int_0^b (-5/2 + 5/2 x/b) Fb 1/EJ dx + \int_0^b (-1) \theta dx = [-5/2 x + 5/4 x^2/b]_0^b Fb 1/EJ + [-x]_0^b \theta$$

$$= (-5/2 b + 5/4 b) Fb 1/EJ + (-b) \theta = -1/4 Fb^2/EJ$$

$$L_{FC}^{xo} = \int_0^b (-5/2 + 5x/b - 5/2 x^2/b^2) Fb 1/EJ dx = [-5/2 x + 5/2 x^2/b - 5/6 x^3/b^2]_0^b Fb 1/EJ$$

$$= (-5/2 b + 5/2 b - 5/6 b) Fb 1/EJ = -5/6 Fb^2/EJ$$

$$L_{CF}^{xo} = \int_0^b (-5/2 x^2/b^2) Fb 1/EJ dx = [-5/6 x^3/b^2]_0^b Fb 1/EJ$$

$$= (-5/6 b) Fb 1/EJ = -5/6 Fb^2/EJ$$

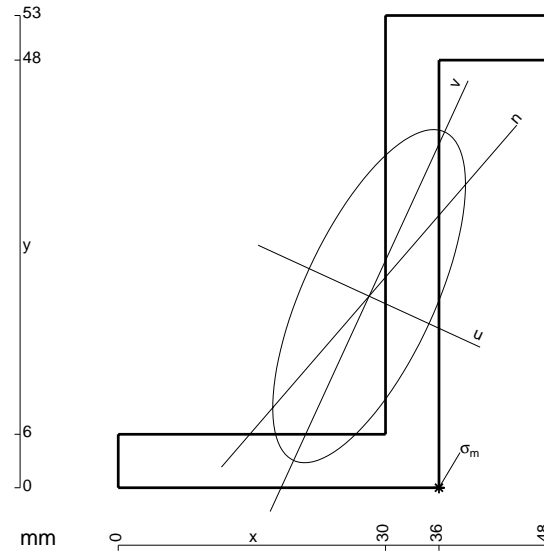

- A = 558. mm²
- J_x = 195119. mm⁴
- J_y = 65290. mm⁴
- J_{xy} = 75600. mm⁴
- J_u = 229850. mm⁴
- J_v = 30558. mm⁴
- α = artg(2J_{xy}/(J_y-J_x))/2 = -.4306
- c = cosα = .9087
- s = sinα = -.4175
- x_g = 28.16 mm
- y_g = 21.5 mm
- N = -1203. N
- T_y = 1625. N
- M_x = 841750. Nmm
- x_m = 36. mm
- u_m = 16.1 mm
- v_m = -16.26 mm
- σ_m = N/A - Mcv/J_u - Msu/J_v = 237.1 N/mm²

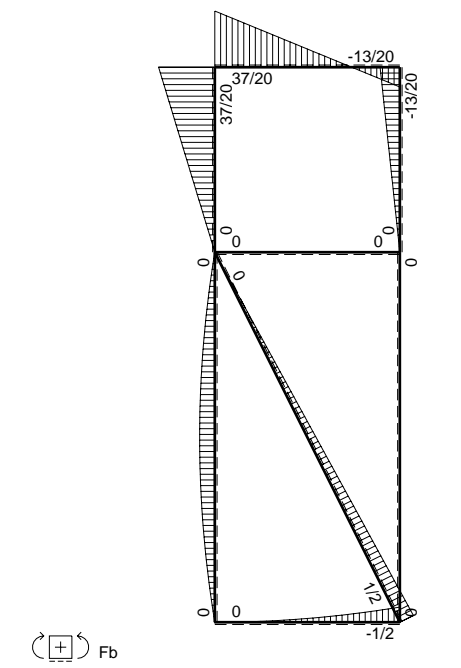
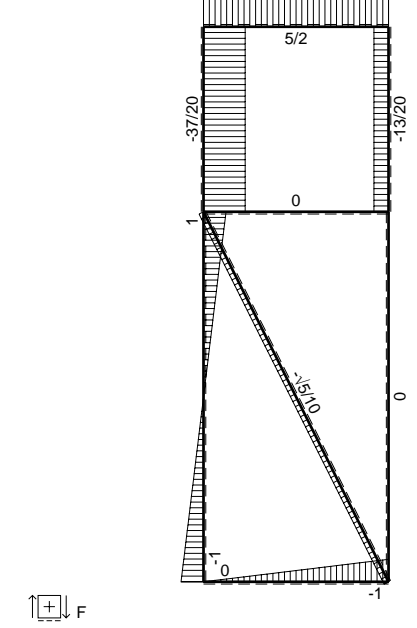
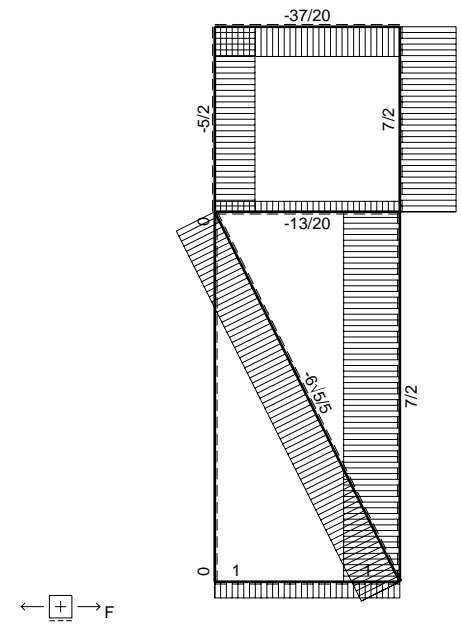
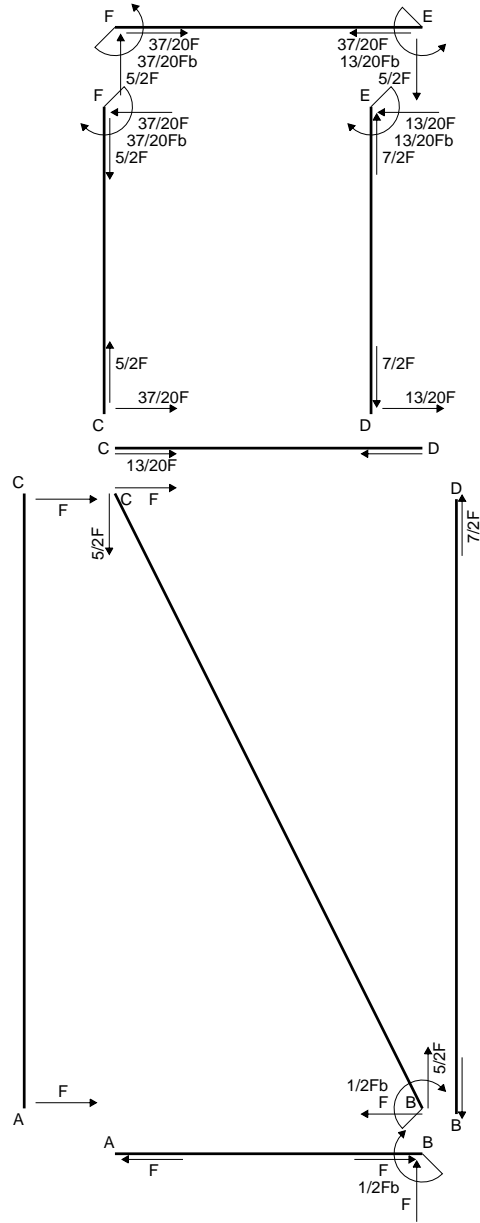

$$L_{DE}^{xx} = \int_0^b (x^2/b^2) 1/EJ dx = [1/3 x^3/b^2]_0^b 1/EJ$$

$$= (1/3 b) 1/EJ = 1/3 b/EJ$$

$$L_{ED}^{xx} = \int_0^b (1 - 2x/b + x^2/b^2) 1/EJ dx = [x - x^2/b + 1/3 x^3/b^2]_0^b 1/EJ$$

$$= (b - b + 1/3 b) 1/EJ = 1/3 b/EJ$$

$$L_{EF}^{xx} = \int_0^b (1) 1/EJ dx = [x]_0^b 1/EJ$$

$$= (b) 1/EJ = b/EJ$$

$$L_{FE}^{xx} = \int_0^b (1) 1/EJ dx = [x]_0^b 1/EJ$$

$$= (b) 1/EJ = b/EJ$$

$$L_{FC}^{xx} = \int_0^b (1 - 2x/b + x^2/b^2) 1/EJ dx = [x - x^2/b + 1/3 x^3/b^2]_0^b 1/EJ$$

$$= (b - b + 1/3 b) 1/EJ = 1/3 b/EJ$$

$$L_{CF}^{xx} = \int_0^b (x^2/b^2) 1/EJ dx = [1/3 x^3/b^2]_0^b 1/EJ$$

$$= (1/3 b) 1/EJ = 1/3 b/EJ$$

$$L_{EF}^{xo} = \int_0^b (-5/2 x/b) Fb 1/EJ dx + \int_0^b (1) \theta dx = [-5/4 x^2/b]_0^b Fb 1/EJ + [x]_0^b \theta$$

$$= (-5/4 b) Fb 1/EJ + (b) \theta = -1/4 Fb^2/EJ$$

$$L_{FE}^{xo} = \int_0^b (-5/2 + 5/2 x/b) Fb 1/EJ dx + \int_0^b (-1) \theta dx = [-5/2 x + 5/4 x^2/b]_0^b Fb 1/EJ + [-x]_0^b \theta$$

$$= (-5/2 b + 5/4 b) Fb 1/EJ + (-b) \theta = -1/4 Fb^2/EJ$$

$$L_{FC}^{xo} = \int_0^b (-5/2 + 5x/b - 5/2 x^2/b^2) Fb 1/EJ dx = [-5/2 x + 5/2 x^2/b - 5/6 x^3/b^2]_0^b Fb 1/EJ$$

$$= (-5/2 b + 5/2 b - 5/6 b) Fb 1/EJ = -5/6 Fb^2/EJ$$

$$L_{CF}^{xo} = \int_0^b (-5/2 x^2/b^2) Fb 1/EJ dx = [-5/6 x^3/b^2]_0^b Fb 1/EJ$$

$$= (-5/6 b) Fb 1/EJ = -5/6 Fb^2/EJ$$

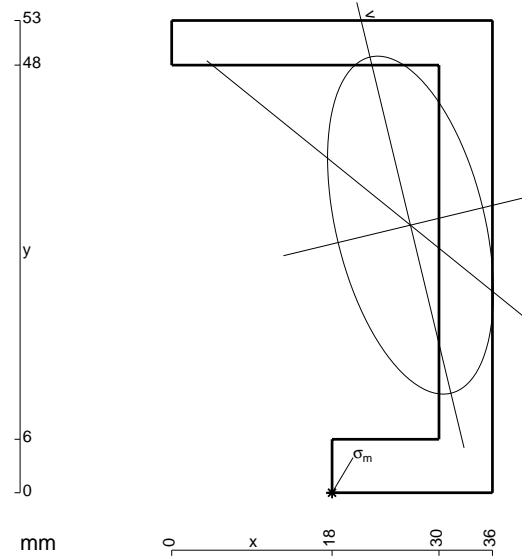

- A = 540. mm²
- J_x = 194387. mm⁴
- J_y = 46742. mm⁴
- J_{xy} = -37742. mm⁴
- J_u = 203476. mm⁴
- J_v = 37654. mm⁴
- α = artg(2J_{xy}/(J_y-J_x))/2 = .2363
- c = cos α = .9722
- s = sin α = .2341
- x_g = 26.8 mm
- y_g = 30.03 mm
- N = -2424. N
- T_y = 3275. N
- M_x = 896695. Nmm
- x_m = 18. mm
- u_m = -15.59 mm
- v_m = -27.14 mm
- σ_m = N/A - Mcv/J_u - Msu/J_v = 198.7 N/mm²

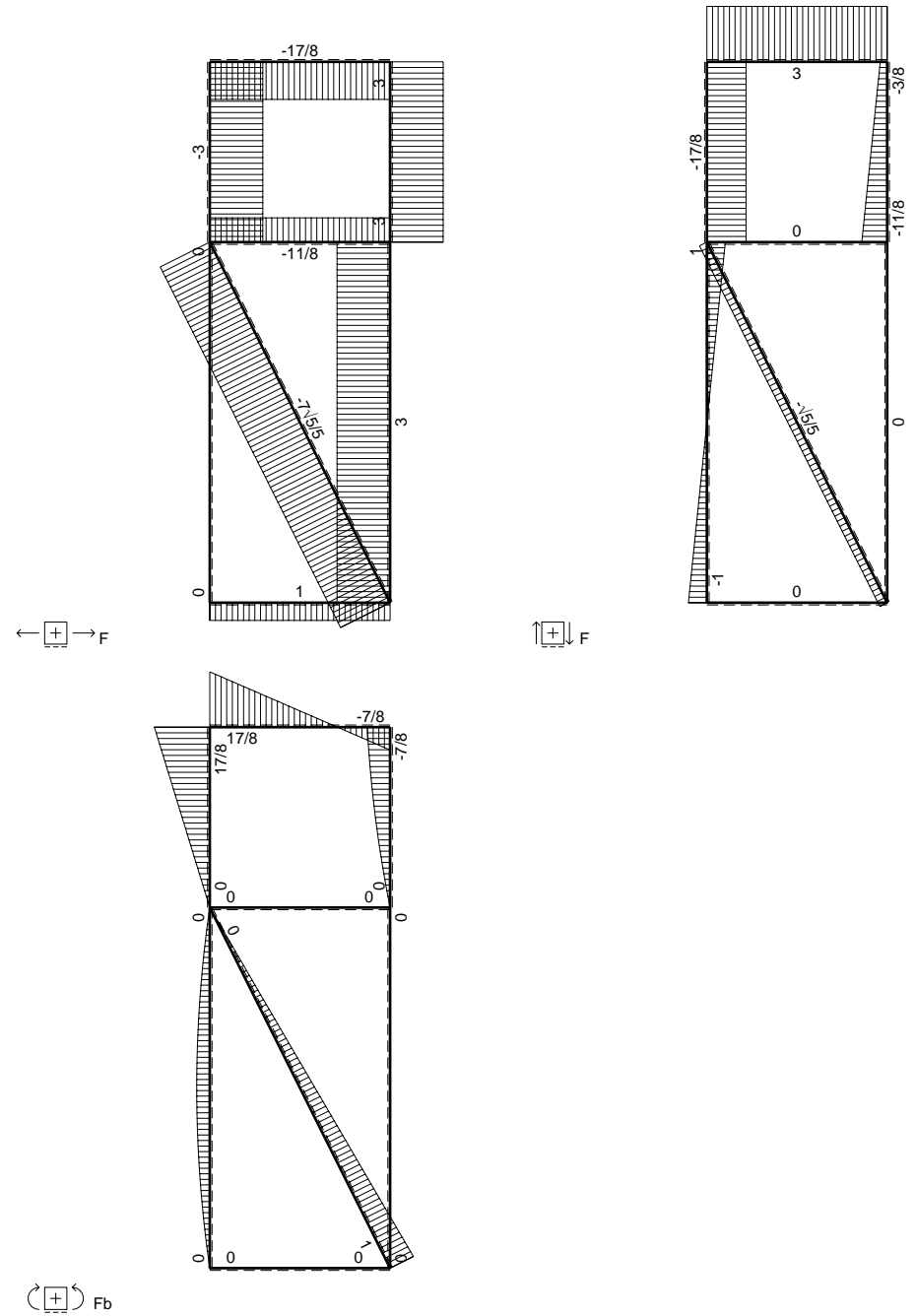
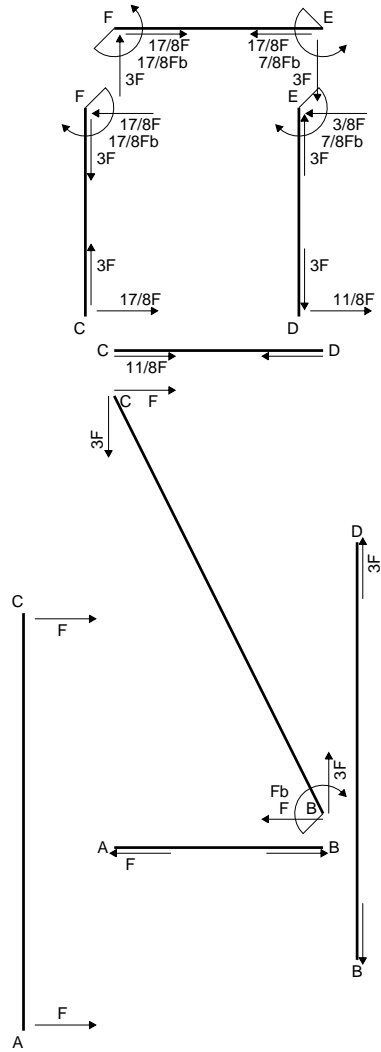

$$L_{DE}^{xx} = \int_0^b (x^2/b^2) 1/EJ dx = [1/3 x^3/b^2]_0^b 1/EJ$$

$$= (1/3 b) 1/EJ = 1/3 b/EJ$$

$$L_{ED}^{xx} = \int_0^b (1 - 2x/b + x^2/b^2) 1/EJ dx = [x - x^2/b + 1/3 x^3/b^2]_0^b 1/EJ$$

$$= (b - b + 1/3 b) 1/EJ = 1/3 b/EJ$$

$$L_{EF}^{xx} = \int_0^b (1) 1/EJ dx = [x]_0^b 1/EJ$$

$$= (b) 1/EJ = b/EJ$$

$$L_{FE}^{xx} = \int_0^b (1) 1/EJ dx = [x]_0^b 1/EJ$$

$$= (b) 1/EJ = b/EJ$$

$$L_{FC}^{xx} = \int_0^b (1 - 2x/b + x^2/b^2) 1/EJ dx = [x - x^2/b + 1/3 x^3/b^2]_0^b 1/EJ$$

$$= (b - b + 1/3 b) 1/EJ = 1/3 b/EJ$$

$$L_{CF}^{xx} = \int_0^b (x^2/b^2) 1/EJ dx = [1/3 x^3/b^2]_0^b 1/EJ$$

$$= (1/3 b) 1/EJ = 1/3 b/EJ$$

$$L_{DE}^{xo} = \int_0^b (1/2 x^2/b^2 - 1/2 x^3/b^3) Fb 1/EJ dx = [1/6 x^3/b^2 - 1/8 x^4/b^3]_0^b Fb 1/EJ$$

$$= (1/6 b - 1/8 b) Fb 1/EJ = 1/24 Fb^2/EJ$$

$$L_{ED}^{xo} = \int_0^b (1/2 x/b - x^2/b^2 + 1/2 x^3/b^3) Fb 1/EJ dx = [1/4 x^2/b - 1/3 x^3/b^2 + 1/8 x^4/b^3]_0^b Fb 1/EJ$$

$$= (1/4 b - 1/3 b + 1/8 b) Fb 1/EJ = 1/24 Fb^2/EJ$$

$$L_{EF}^{xo} = \int_0^b (-3x/b) Fb 1/EJ dx + \int_0^b (1) \theta dx = [-3/2 x^2/b]_0^b Fb 1/EJ + [x]_0^b \theta$$

$$= (-3/2 b) Fb 1/EJ + (b) \theta = -1/2 Fb^2/EJ$$

$$L_{FE}^{xo} = \int_0^b (-3 + 3x/b) Fb 1/EJ dx + \int_0^b (-1) \theta dx = [-3x + 3/2 x^2/b]_0^b Fb 1/EJ + [-x]_0^b \theta$$

$$= (-3b + 3/2 b) Fb 1/EJ + (-b) \theta = -1/2 Fb^2/EJ$$

$$L_{FC}^{xo} = \int_0^b (-3 + 6x/b - 3x^2/b^2) Fb 1/EJ dx = [-3x + 3x^2/b - x^3/b^2]_0^b Fb 1/EJ$$

$$= (-3b + 3b - b) Fb 1/EJ = - Fb^2/EJ$$

$$L_{CF}^{xo} = \int_0^b (-3x^2/b^2) Fb 1/EJ dx = [-x^3/b^2]_0^b Fb 1/EJ$$

$$= (-b) Fb 1/EJ = - Fb^2/EJ$$

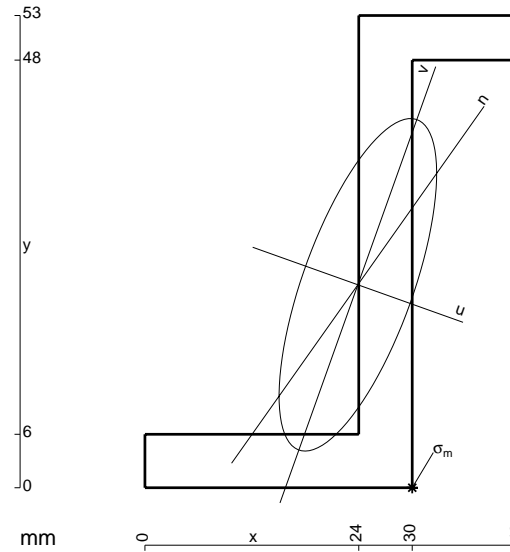

- A = 522. mm²
- J_x = 181840. mm⁴
- J_y = 40818. mm⁴
- J_{xy} = 57687. mm⁴
- J_u = 202431. mm⁴
- J_v = 20227. mm⁴
- α = arctg(2J_{xy}/(J_y-J_x))/2 = -.3428
- c = cos α = .9418
- s = sin α = -.3362
- x_g = 23.9 mm
- y_g = 22.78 mm
- N = -1700. N
- T_y = 2400. N
- M_x = 680000. Nmm
- x_m = 30. mm
- u_m = 13.4 mm
- v_m = -19.4 mm
- σ_m = N/A - Mcv/J_u - Msu/J_v = 209.6 N/mm²

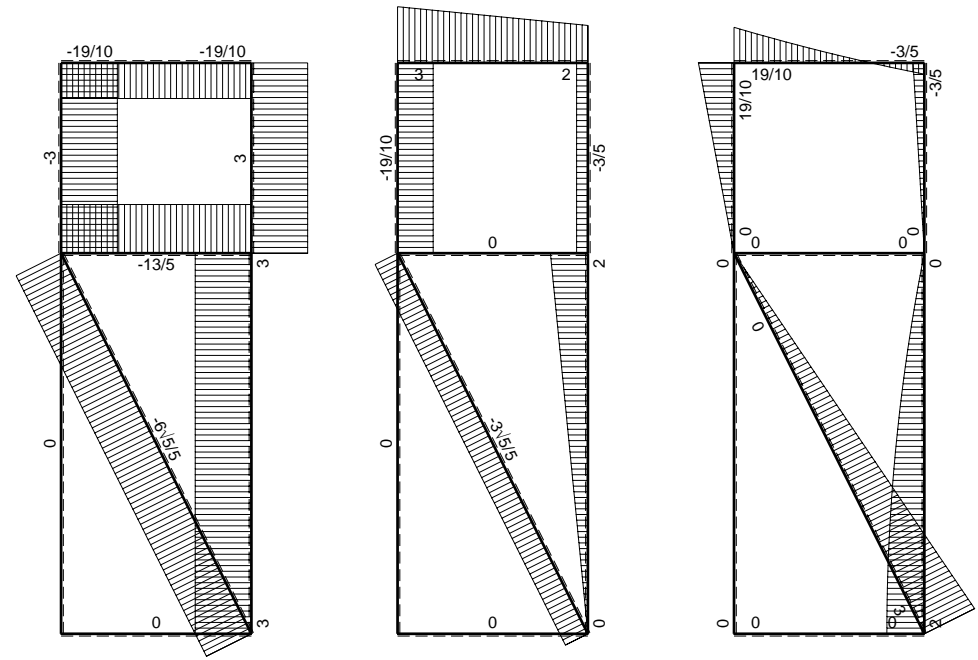
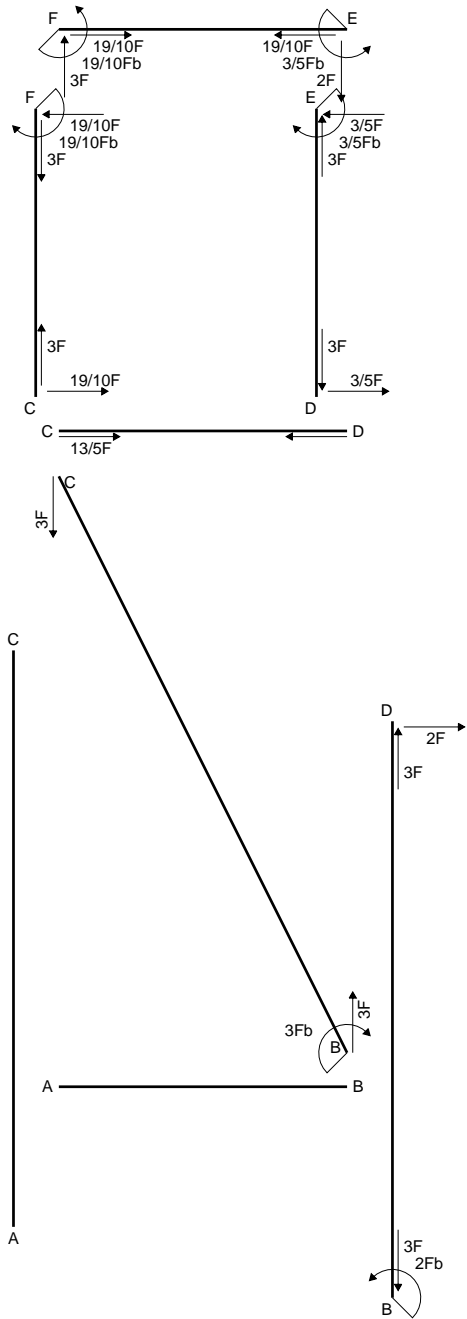

← ⊕ → F

↑ ⊕ ↓ F

⊕ ⊖ F_b

$$L_{DE}^{xx} = \int_0^b (x^2/b^2) 1/EJ dx = [1/3 x^3/b^2]_0^b 1/EJ$$

$$= (1/3 b) 1/EJ = 1/3 b/EJ$$

$$L_{ED}^{xx} = \int_0^b (1 - 2x/b + x^2/b^2) 1/EJ dx = [x - x^2/b + 1/3 x^3/b^2]_0^b 1/EJ$$

$$= (b - b + 1/3 b) 1/EJ = 1/3 b/EJ$$

$$L_{EF}^{xx} = \int_0^b (1) 1/EJ dx = [x]_0^b 1/EJ$$

$$= (b) 1/EJ = b/EJ$$

$$L_{FE}^{xx} = \int_0^b (1) 1/EJ dx = [x]_0^b 1/EJ$$

$$= (b) 1/EJ = b/EJ$$

$$L_{FC}^{xx} = \int_0^b (1 - 2x/b + x^2/b^2) 1/EJ dx = [x - x^2/b + 1/3 x^3/b^2]_0^b 1/EJ$$

$$= (b - b + 1/3 b) 1/EJ = 1/3 b/EJ$$

$$L_{CF}^{xx} = \int_0^b (x^2/b^2) 1/EJ dx = [1/3 x^3/b^2]_0^b 1/EJ$$

$$= (1/3 b) 1/EJ = 1/3 b/EJ$$

$$L_{EF}^{xo} = \int_0^b (-2x/b - 1/2 x^2/b^2) Fb 1/EJ dx + \int_0^b (1) \theta dx = [-x^2/b - 1/6 x^3/b^2]_0^b Fb 1/EJ + [x]_0^b \theta$$

$$= (-b - 1/6 b) Fb 1/EJ + (b) \theta = -1/6 Fb^2/EJ$$

$$L_{FE}^{xo} = \int_0^b (-5/2 + 3x/b - 1/2 x^2/b^2) Fb 1/EJ dx + \int_0^b (-1) \theta dx$$

$$= [-5/2 x + 3/2 x^2/b - 1/6 x^3/b^2]_0^b Fb 1/EJ + [-x]_0^b \theta$$

$$= (-5/2 b + 3/2 b - 1/6 b) Fb 1/EJ + (-b) \theta = -1/6 Fb^2/EJ$$

$$L_{FC}^{xo} = \int_0^b (-5/2 + 5x/b - 5/2 x^2/b^2) Fb 1/EJ dx = [-5/2 x + 5/2 x^2/b - 5/6 x^3/b^2]_0^b Fb 1/EJ$$

$$= (-5/2 b + 5/2 b - 5/6 b) Fb 1/EJ = -5/6 Fb^2/EJ$$

$$L_{CF}^{xo} = \int_0^b (-5/2 x^2/b^2) Fb 1/EJ dx = [-5/6 x^3/b^2]_0^b Fb 1/EJ$$

$$= (-5/6 b) Fb 1/EJ = -5/6 Fb^2/EJ$$

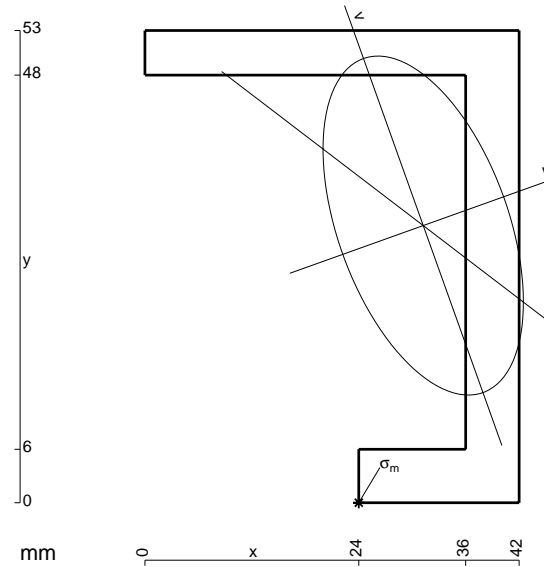

- A = 570. mm²
- J_x = 206355. mm⁴
- J_y = 72071. mm⁴
- J_{xy} = -55077. mm⁴
- J_u = 226055. mm⁴
- J_v = 52372. mm⁴
- α = arctg(2J_{xy}/(J_y-J_x))/2 = .3435
- c = cos α = .9416
- s = sin α = .3368
- x_g = 31.23 mm
- y_g = 31.11 mm
- N = -2012. N
- T_y = -1006. N
- M_x = 990000. Nmm
- x_m = 24. mm
- u_m = -17.29 mm
- v_m = -26.86 mm
- σ_m = N/A - Mcv/J_u - Msu/J_v = 217.3 N/mm²

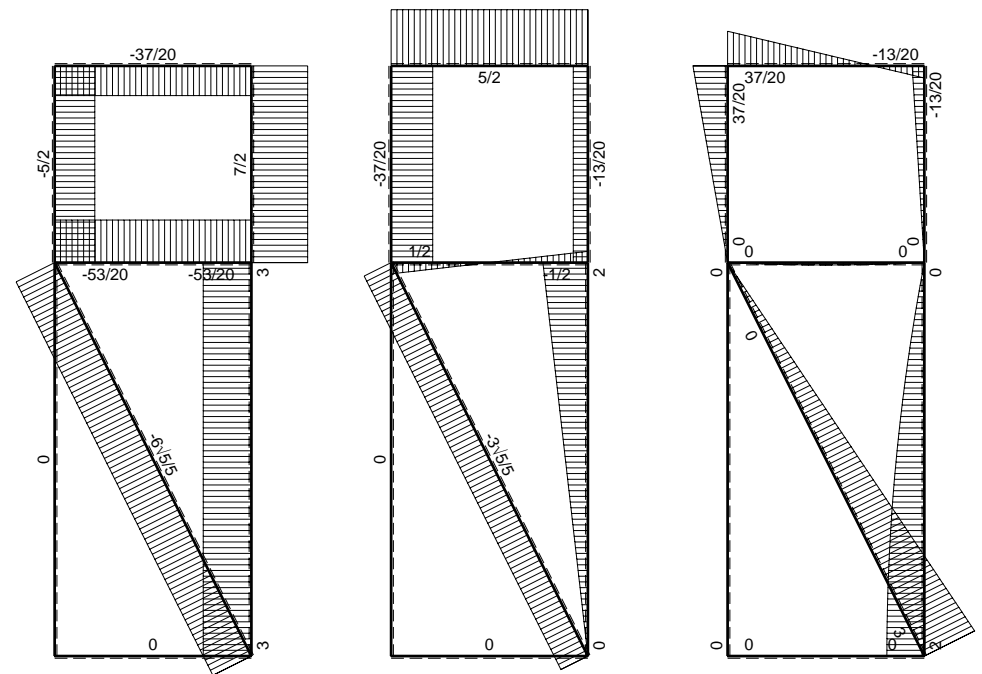
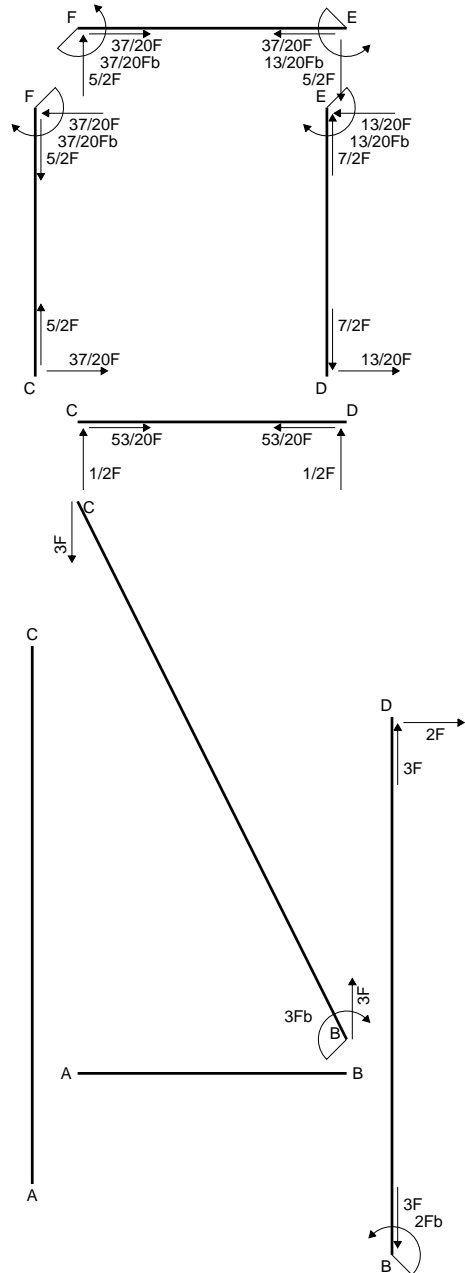

← ⊕ → F

⊕ ⊖ F

⊕ ⊖ F_b

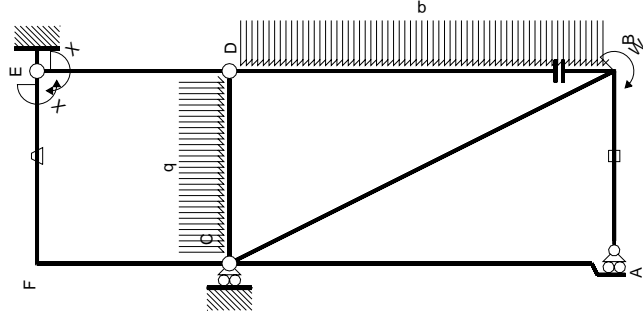

Schema di calcolo iperstatico

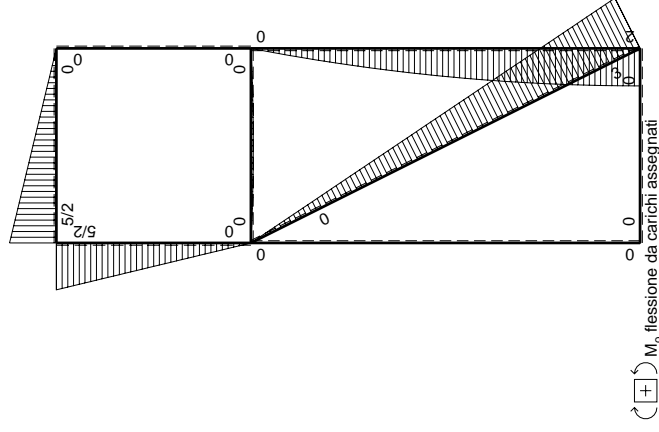

M_0 flessione da carichi assegnati

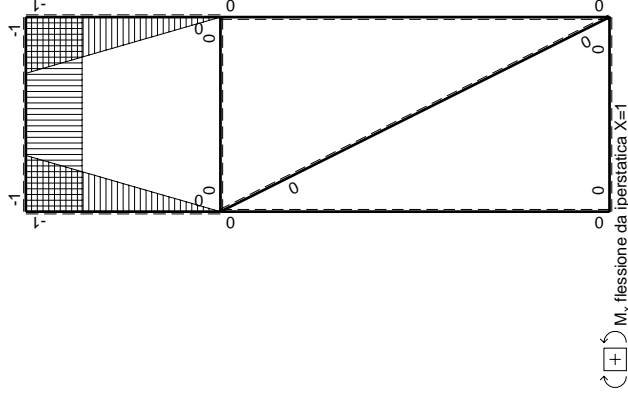

M_x flessione da iperstatica $X=1$

Quadro contributi PLV per iperstatica $X=W_{EP}$

\leftarrow	$M^x(x)$	$M^0(x)$	θ	$M^x M^0$	$M^x \theta$	$M^x M^x$	$\int M^x(M^0/EJ+\theta)dx$	$\int M^x M^x/EJ dx$
AB b	0	0	0	0	0	0	0+0	0
BA b	0	0	0	0	0	0	0	0
BC $\sqrt{5}b$	0	$3Fb-3\sqrt{5}/5Fx$	0	0	0	0	0+0	0
AC 2b	0	0	0	0	0	0	0+0	0
CA 2b	0	0	0	0	0	0	0+0	0
DB 2b	0	$2Fx-1/2qx^2$	0	0	0	0	0+0	0
BD 2b	0	$-2Fb+1/2qx^2$	0	0	0	0	0+0	0
DE b	-x/b	0	0	0	0	x^2/b^2	0+0	$1/3xb/EJ$
ED b	1-x/b	0	0	0	0	$1-2x/b+x^2/b^2$	0+0	$1/3xb/EJ$
CD b	0	$1/2Fx-1/2qx^2$	0	0	0	0	0	0
DC b	0	$-1/2Fx+1/2qx^2$	0	0	0	0	0+0	0
EF b	-1	$5/2Fx$	-Fb/EJ	-5/2Fx	Fb/EJ	1	$(-5/4+1)Fb^2/EJ$	Xb/EJ
FE b	1	$-5/2Fb+5/2Fx$	Fb/EJ	-5/2Fb+5/2Fx	Fb/EJ	1	$(-5/4+1)Fb^2/EJ$	Xb/EJ
FC b	-1+x/b	$5/2Fb-5/2Fx$	0	$-5/2Fb+5Fx-5/2Fx^2/b$	0	$1-2x/b+x^2/b^2$	$(-5/6+0)Fb^2/EJ$	$1/3xb/EJ$
CF b	x/b	-5/2Fx	0	-5/2Fx ² /b	0	x^2/b^2	-13/12Fb ² /EJ	$5/3xb/EJ$
totali								
		iperstatica $X=W_{EP}$						
		13/20Fb						

Sviluppi di calcolo iperstatica

$$L_{DE}^{xx} = \int_0^b (x^2/b^2) 1/EJ dx = [1/3 x^3/b^2]_0^b 1/EJ$$

$$= (1/3 b) 1/EJ = 1/3 b/EJ$$

$$L_{ED}^{xx} = \int_0^b (1 - 2x/b + x^2/b^2) 1/EJ dx = [x - x^2/b + 1/3 x^3/b^2]_0^b 1/EJ$$

$$= (b - b + 1/3 b) 1/EJ = 1/3 b/EJ$$

$$L_{EF}^{xx} = \int_0^b (1) 1/EJ dx = [x]_0^b 1/EJ$$

$$= (b) 1/EJ = b/EJ$$

$$L_{FE}^{xx} = \int_0^b (1) 1/EJ dx = [x]_0^b 1/EJ$$

$$= (b) 1/EJ = b/EJ$$

$$L_{FC}^{xx} = \int_0^b (1 - 2x/b + x^2/b^2) 1/EJ dx = [x - x^2/b + 1/3 x^3/b^2]_0^b 1/EJ$$

$$= (b - b + 1/3 b) 1/EJ = 1/3 b/EJ$$

$$L_{CF}^{xx} = \int_0^b (x^2/b^2) 1/EJ dx = [1/3 x^3/b^2]_0^b 1/EJ$$

$$= (1/3 b) 1/EJ = 1/3 b/EJ$$

$$L_{EF}^{xo} = \int_0^b (-5/2 x/b) Fb 1/EJ dx + \int_0^b (1) \theta dx = [-5/4 x^2/b]_0^b Fb 1/EJ + [x]_0^b \theta$$

$$= (-5/4 b) Fb 1/EJ + (b) \theta = -1/4 Fb^2/EJ$$

$$L_{FE}^{xo} = \int_0^b (-5/2 + 5/2 x/b) Fb 1/EJ dx + \int_0^b (-1) \theta dx = [-5/2 x + 5/4 x^2/b]_0^b Fb 1/EJ + [-x]_0^b \theta$$

$$= (-5/2 b + 5/4 b) Fb 1/EJ + (-b) \theta = -1/4 Fb^2/EJ$$

$$L_{FC}^{xo} = \int_0^b (-5/2 + 5x/b - 5/2 x^2/b^2) Fb 1/EJ dx = [-5/2 x + 5/2 x^2/b - 5/6 x^3/b^2]_0^b Fb 1/EJ$$

$$= (-5/2 b + 5/2 b - 5/6 b) Fb 1/EJ = -5/6 Fb^2/EJ$$

$$L_{CF}^{xo} = \int_0^b (-5/2 x^2/b^2) Fb 1/EJ dx = [-5/6 x^3/b^2]_0^b Fb 1/EJ$$

$$= (-5/6 b) Fb 1/EJ = -5/6 Fb^2/EJ$$

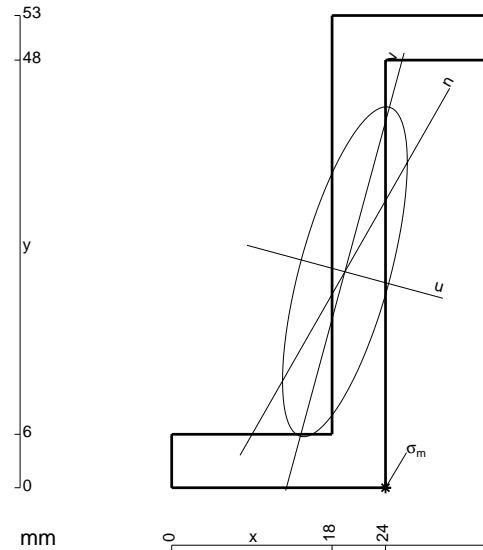

- A = 486. mm²
- J_x = 166610. mm⁴
- J_y = 23826. mm⁴
- J_{xy} = 41708. mm⁴
- J_u = 177900. mm⁴
- J_v = 12536. mm⁴
- α = arctg(2J_{xy}/(J_y-J_x))/2 = -.2644
- c = cos α = .9653
- s = sin α = -.2613
- x_g = 19.44 mm
- y_g = 24.24 mm
- N = -1234. N
- T_y = -617.2 N
- M_x = 662400. Nmm
- x_m = 24. mm
- u_m = 10.73 mm
- v_m = -22.21 mm
- σ_m = N/A - Mcv/J_v - Msu/J_u = 225.4 N/mm²

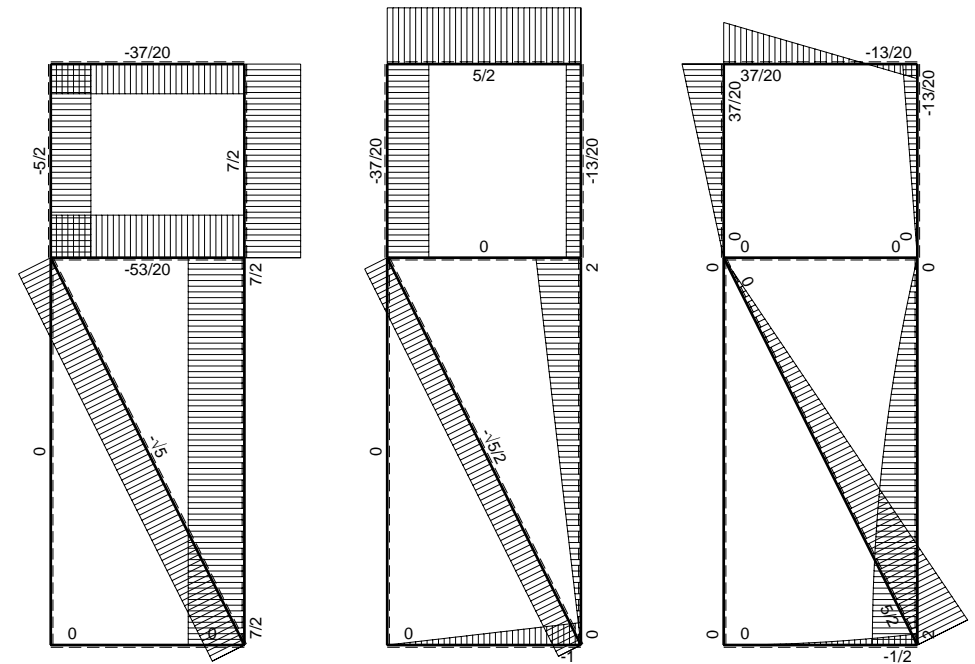
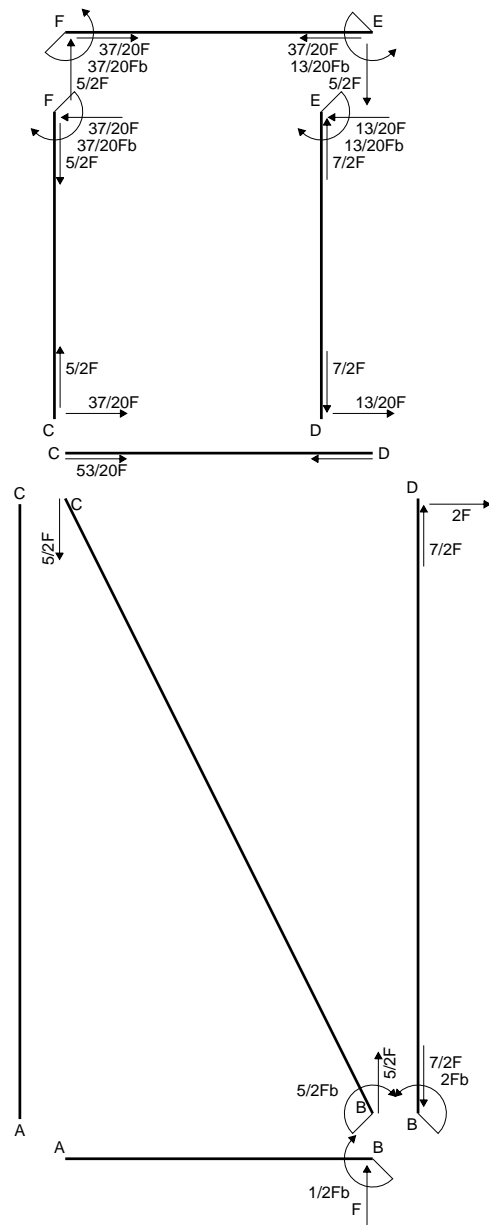

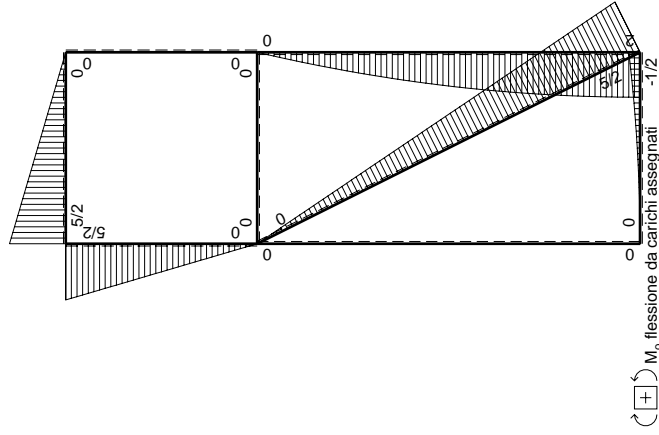
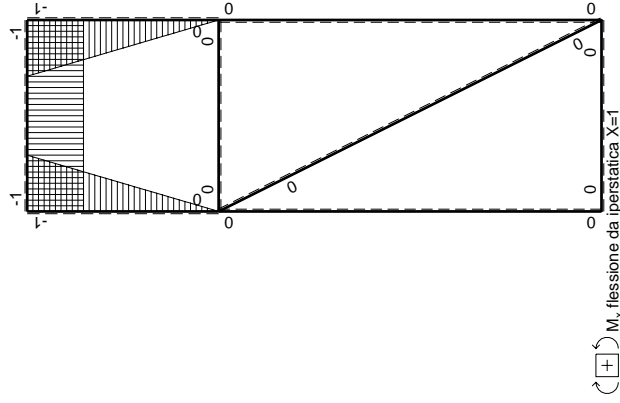
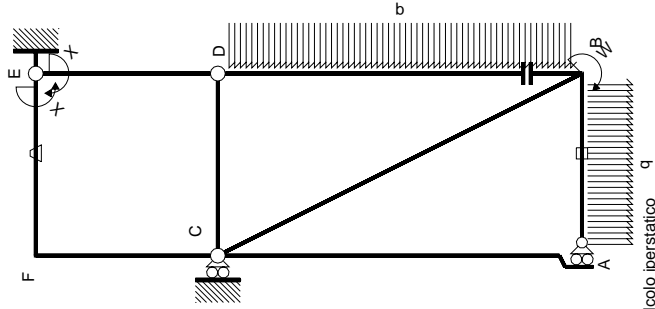

Quadro contributi PLV per iperstatica $X=W_{EP}$

\rightarrow	$M(x)$	$M_0(x)$	θ	$M_x M_0$	$M_x \theta$	$M_x M_x$	$\int M_x(M_0/EJ+\theta)dx$	$\int M_x M_x/EJ dx$
AB b	0	$-1/2qx^2$	0	0	0	0	0	0
BA b	0	$1/2Fb-Fx+1/2qx^2$	0	0	0	0	0	0
BC $\sqrt{5}b$	0	$5/2Fb-\sqrt{5}2Fx$	0	0	0	0	0	0
CA 2b	0	0	0	0	0	0	0	0
AC 2b	0	0	0	0	0	0	0	0
DB 2b	0	$2Fx-1/2qx^2$	0	0	0	0	0	0
BD 2b	0	$-2Fb+1/2qx^2$	0	0	0	0	0	0
DE b	$-x/b$	0	0	0	0	x^2/b^2	0	0
ED b	$1-x/b$	0	0	0	0	$1-2x/b+x^2/b^2$	0	$1/3xb/EJ$
CD b	0	0	0	0	0	0	0	0
DC b	0	0	0	0	0	0	0	0
EF b	-1	$5/2Fx$	$-Fb/EJ$	$-5/2Fx$	Fb/EJ	1	$(-5/4+1)Fb^2/EJ$	xb/EJ
FE b	1	$-5/2Fb+5/2Fx$	Fb/EJ	$-5/2Fb+5/2Fx$	Fb/EJ	1	$(-5/4+1)Fb^2/EJ$	xb/EJ
FC b	$-1+x/b$	$5/2Fb-5/2Fx$	0	$-5/2Fb+5Fx-5/2Fx^2/b$	0	$1-2x/b+x^2/b^2$	$(-5/6+0)Fb^2/EJ$	$1/3xb/EJ$
CF b	x/b	$-5/2Fx$	0	$-5/2Fx^2/b$	0	x^2/b^2	$-13/12Fb^2/EJ$	$5/3xb/EJ$
totali								
iperstatica $X=W_{EP}$								

Sviluppi di calcolo iperstatica

$$L_{DE}^{xx} = \int_0^b (x^2/b^2) 1/EJ dx = [1/3 x^3/b^2]_0^b 1/EJ$$

$$= (1/3 b) 1/EJ = 1/3 b/EJ$$

$$L_{ED}^{xx} = \int_0^b (1 - 2x/b + x^2/b^2) 1/EJ dx = [x - x^2/b + 1/3 x^3/b^2]_0^b 1/EJ$$

$$= (b - b + 1/3 b) 1/EJ = 1/3 b/EJ$$

$$L_{EF}^{xx} = \int_0^b (1) 1/EJ dx = [x]_0^b 1/EJ$$

$$= (b) 1/EJ = b/EJ$$

$$L_{FE}^{xx} = \int_0^b (1) 1/EJ dx = [x]_0^b 1/EJ$$

$$= (b) 1/EJ = b/EJ$$

$$L_{FC}^{xx} = \int_0^b (1 - 2x/b + x^2/b^2) 1/EJ dx = [x - x^2/b + 1/3 x^3/b^2]_0^b 1/EJ$$

$$= (b - b + 1/3 b) 1/EJ = 1/3 b/EJ$$

$$L_{CF}^{xx} = \int_0^b (x^2/b^2) 1/EJ dx = [1/3 x^3/b^2]_0^b 1/EJ$$

$$= (1/3 b) 1/EJ = 1/3 b/EJ$$

$$L_{EF}^{xo} = \int_0^b (-5/2 x/b) Fb 1/EJ dx + \int_0^b (1) \theta dx = [-5/4 x^2/b]_0^b Fb 1/EJ + [x]_0^b \theta$$

$$= (-5/4 b) Fb 1/EJ + (b) \theta = -1/4 Fb^2/EJ$$

$$L_{FE}^{xo} = \int_0^b (-5/2 + 5/2 x/b) Fb 1/EJ dx + \int_0^b (-1) \theta dx = [-5/2 x + 5/4 x^2/b]_0^b Fb 1/EJ + [-x]_0^b \theta$$

$$= (-5/2 b + 5/4 b) Fb 1/EJ + (-b) \theta = -1/4 Fb^2/EJ$$

$$L_{FC}^{xo} = \int_0^b (-5/2 + 5x/b - 5/2 x^2/b^2) Fb 1/EJ dx = [-5/2 x + 5/2 x^2/b - 5/6 x^3/b^2]_0^b Fb 1/EJ$$

$$= (-5/2 b + 5/2 b - 5/6 b) Fb 1/EJ = -5/6 Fb^2/EJ$$

$$L_{CF}^{xo} = \int_0^b (-5/2 x^2/b^2) Fb 1/EJ dx = [-5/6 x^3/b^2]_0^b Fb 1/EJ$$

$$= (-5/6 b) Fb 1/EJ = -5/6 Fb^2/EJ$$

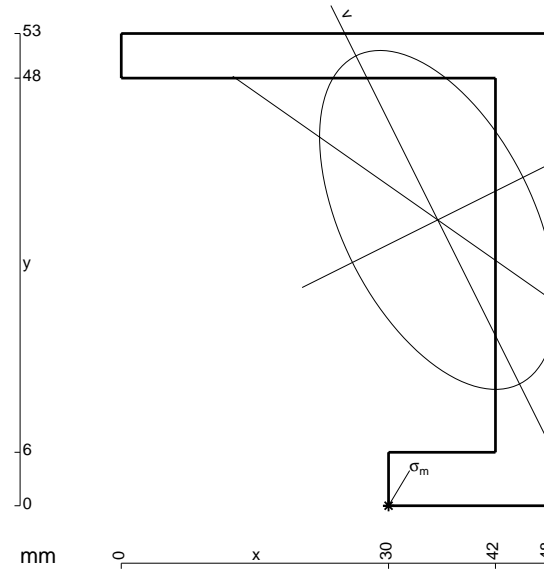

- A = 600. mm²
- J_x = 217132. mm⁴
- J_y = 105558. mm⁴
- J_{xy} = -73993. mm⁴
- J_u = 254012. mm⁴
- J_v = 68678. mm⁴
- α = artg(2J_{xy}/(J_y-J_x))/2 = .4624
- c = cosα = .8950
- s = sinα = .4461
- x_g = 35.52 mm
- y_g = 32.08 mm
- N = -1945. N
- T_y = -972.7 N
- M_x = 1109250. Nmm
- x_m = 30. mm
- u_m = -19.25 mm
- v_m = -26.25 mm
- σ_m = N/A-Mcv/J_u-Msv/J_v = 238. N/mm²

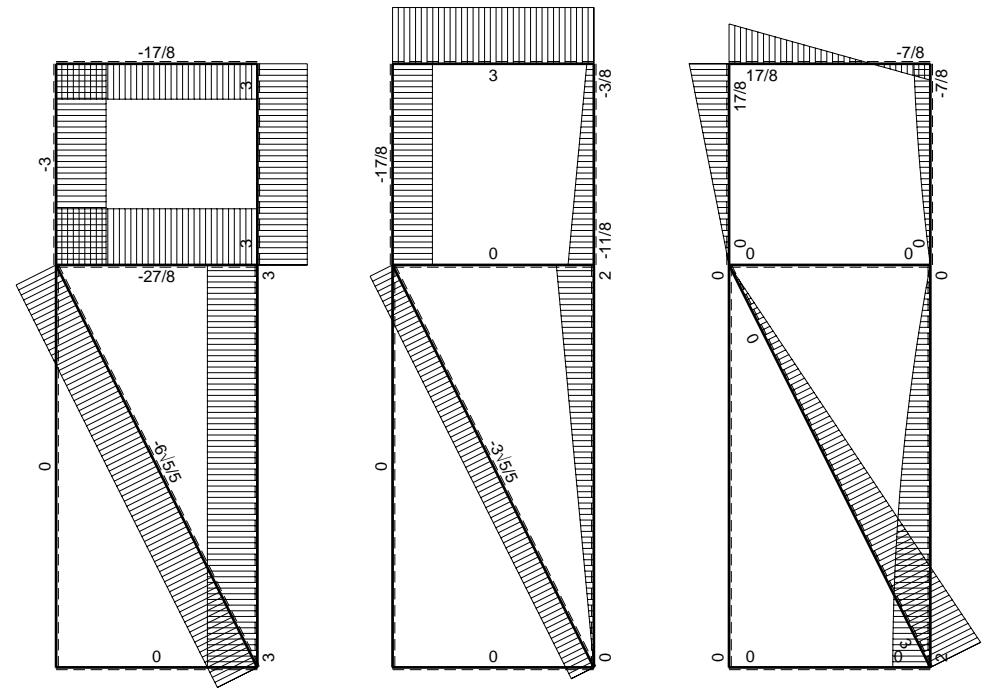
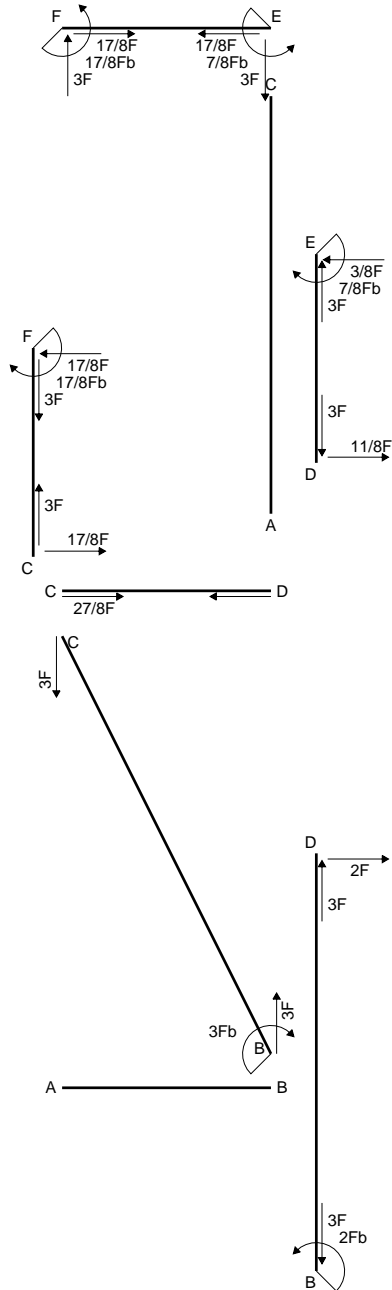

← ⊕ → F

↑ ⊕ ↓ F

⊕ ⊖ F_b

$$L_{DE}^{xx} = \int_0^b (x^2/b^2) 1/EJ dx = [1/3 x^3/b^2]_0^b 1/EJ$$

$$= (1/3 b) 1/EJ = 1/3 b/EJ$$

$$L_{ED}^{xx} = \int_0^b (1 - 2x/b + x^2/b^2) 1/EJ dx = [x - x^2/b + 1/3 x^3/b^2]_0^b 1/EJ$$

$$= (b - b + 1/3 b) 1/EJ = 1/3 b/EJ$$

$$L_{EF}^{xx} = \int_0^b (1) 1/EJ dx = [x]_0^b 1/EJ$$

$$= (b) 1/EJ = b/EJ$$

$$L_{FE}^{xx} = \int_0^b (1) 1/EJ dx = [x]_0^b 1/EJ$$

$$= (b) 1/EJ = b/EJ$$

$$L_{FC}^{xx} = \int_0^b (1 - 2x/b + x^2/b^2) 1/EJ dx = [x - x^2/b + 1/3 x^3/b^2]_0^b 1/EJ$$

$$= (b - b + 1/3 b) 1/EJ = 1/3 b/EJ$$

$$L_{CF}^{xx} = \int_0^b (x^2/b^2) 1/EJ dx = [1/3 x^3/b^2]_0^b 1/EJ$$

$$= (1/3 b) 1/EJ = 1/3 b/EJ$$

$$L_{DE}^{xo} = \int_0^b (1/2 x^2/b^2 - 1/2 x^3/b^3) Fb 1/EJ dx = [1/6 x^3/b^2 - 1/8 x^4/b^3]_0^b Fb 1/EJ$$

$$= (1/6 b - 1/8 b) Fb 1/EJ = 1/24 Fb^2/EJ$$

$$L_{ED}^{xo} = \int_0^b (1/2 x/b - x^2/b^2 + 1/2 x^3/b^3) Fb 1/EJ dx = [1/4 x^2/b - 1/3 x^3/b^2 + 1/8 x^4/b^3]_0^b Fb 1/EJ$$

$$= (1/4 b - 1/3 b + 1/8 b) Fb 1/EJ = 1/24 Fb^2/EJ$$

$$L_{EF}^{xo} = \int_0^b (-3x/b) Fb 1/EJ dx + \int_0^b (1) \theta dx = [-3/2 x^2/b]_0^b Fb 1/EJ + [x]_0^b \theta$$

$$= (-3/2 b) Fb 1/EJ + (b) \theta = -1/2 Fb^2/EJ$$

$$L_{FE}^{xo} = \int_0^b (-3 + 3x/b) Fb 1/EJ dx + \int_0^b (-1) \theta dx = [-3x + 3/2 x^2/b]_0^b Fb 1/EJ + [-x]_0^b \theta$$

$$= (-3b + 3/2 b) Fb 1/EJ + (-b) \theta = -1/2 Fb^2/EJ$$

$$L_{FC}^{xo} = \int_0^b (-3 + 6x/b - 3x^2/b^2) Fb 1/EJ dx = [-3x + 3x^2/b - x^3/b^2]_0^b Fb 1/EJ$$

$$= (-3b + 3b - b) Fb 1/EJ = - Fb^2/EJ$$

$$L_{CF}^{xo} = \int_0^b (-3x^2/b^2) Fb 1/EJ dx = [-x^3/b^2]_0^b Fb 1/EJ$$

$$= (-b) Fb 1/EJ = - Fb^2/EJ$$

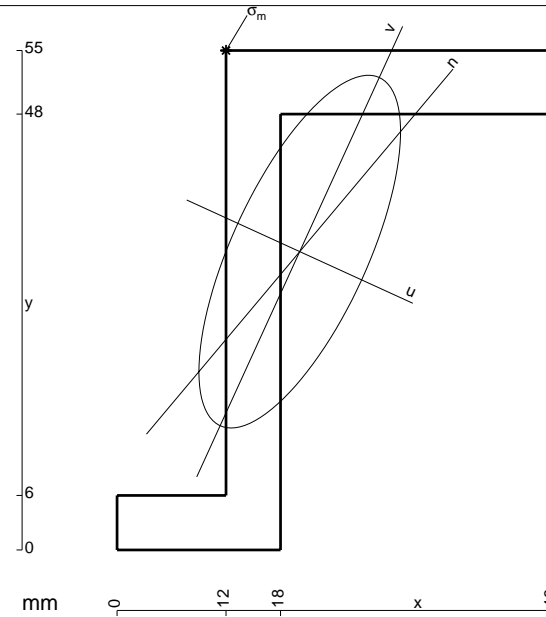

- A = 612. mm²
- J_x = 230903. mm⁴
- J_y = 75448. mm⁴
- J_{xy} = 89831. mm⁴
- J_u = 271965. mm⁴
- J_v = 34385. mm⁴
- α = arctg(2J_{xy}/(J_y-J_x))/2 = -.4288
- c = cosα = .9095
- s = sinα = -.4157
- x_g = 20.12 mm
- y_g = 32.85 mm
- N = -1181. N
- T_y = -590.3 N
- M_x = 765600. Nmm
- x_m = 12. mm
- y_m = 55. mm
- u_m = -16.59 mm
- v_m = 16.77 mm
- σ_m = N/A - Mcv/J_u - Msu/J_v = -198.4 N/mm²

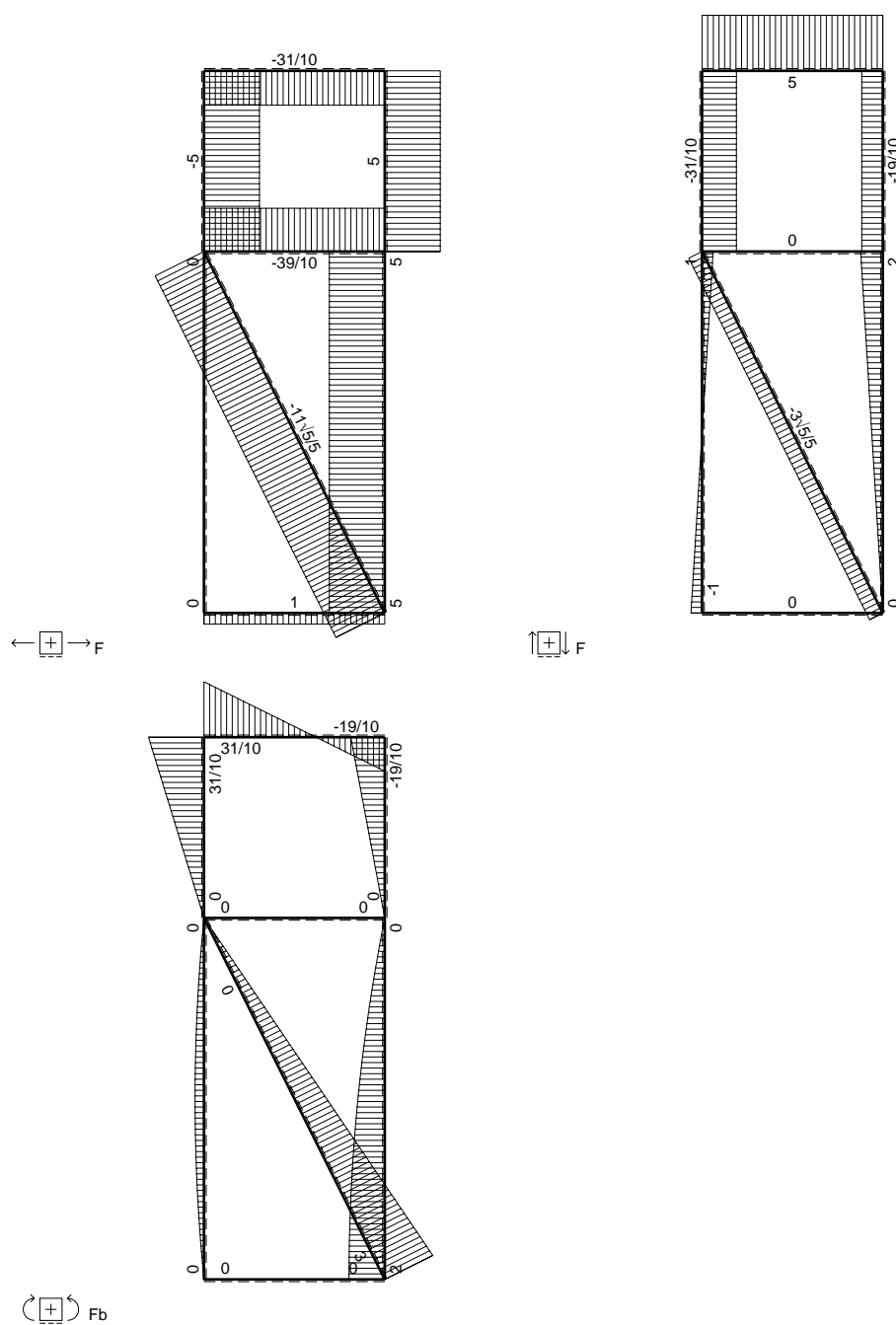
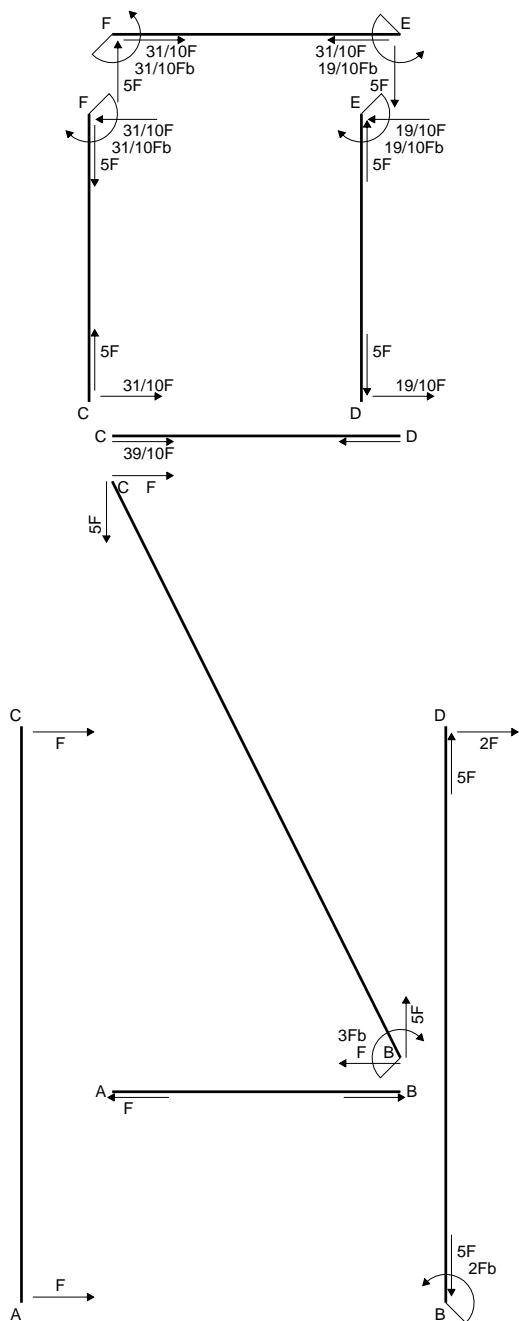

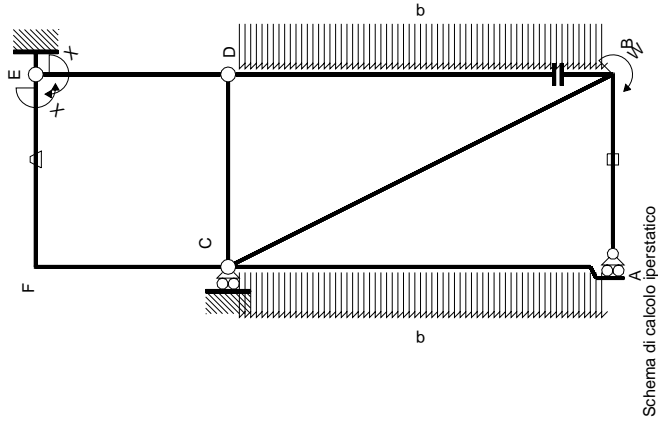

M_0 flessione da carichi assegnati

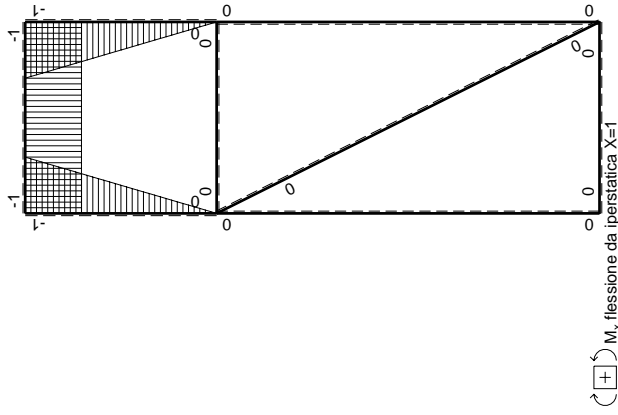

Quadro contributi PLV per iperstatica $X=W_{Ef}$

\rightarrow	$M^x(x)$	$M^0(x)$	θ	$M^x M_0$	$M^x \theta$	$M^x M_x$	$\int M^x (M_0/EJ + \theta) dx$	$\int M^x M_x / EJ dx$
AB b	0	0	0	0	0	0	0	0
BA b	0	0	0	0	0	0	0	0
BC $\sqrt{5}b$	0	$3Fb-3\sqrt{5}/5Fx$	0	0	0	0	0	0
CA 2b	0	$-Fx+1/2qx^2$	0	0	0	0	0	0
DB 2b	0	$2Fx-1/2qx^2$	0	0	0	0	0	0
BD 2b	0	$-2Fb+1/2qx^2$	0	0	0	0	0	0
DE b	$-x/b$	0	0	0	0	x^2/b^2	0	$1/3Xb/EJ$
ED b	$1-x/b$	0	0	0	0	$1-2x/b+x^2/b^2$	0	$1/3Xb/EJ$
CD b	0	0	0	0	0	0	0	0
DC b	0	0	0	0	0	0	0	0
EF b	-1	$5Fx$	$-Fb/EJ$	$-5Fx$	Fb/EJ	1	$(-5/2+1)Fb^2/EJ$	Xb/EJ
FE b	1	$-5Fb+5Fx$	Fb/EJ	$-5Fb+5Fx$	Fb/EJ	1	$(-5/2+1)Fb^2/EJ$	Xb/EJ
FC b	$-1+x/b$	$5Fb-5Fx$	0	$-5Fb+10Fx-5Fx^2/b$	0	$1-2x/b+x^2/b^2$	$(-5/3+0)Fb^2/EJ$	$1/3Xb/EJ$
CF b	x/b	$-5Fx$	0	$-5Fx^2/b$	0	x^2/b^2	$-19/6Fb^2/EJ$	$5/3Xb/EJ$
totali								
								$19/10Fb$

Sviluppi di calcolo iperstatica

$$L_{DE}^{xx} = \int_0^b (x^2/b^2) 1/EJ dx = [1/3 x^3/b^2]_0^b 1/EJ$$

$$= (1/3 b) 1/EJ = 1/3 b/EJ$$

$$L_{ED}^{xx} = \int_0^b (1 - 2x/b + x^2/b^2) 1/EJ dx = [x - x^2/b + 1/3 x^3/b^2]_0^b 1/EJ$$

$$= (b - b + 1/3 b) 1/EJ = 1/3 b/EJ$$

$$L_{EF}^{xx} = \int_0^b (1) 1/EJ dx = [x]_0^b 1/EJ$$

$$= (b) 1/EJ = b/EJ$$

$$L_{FE}^{xx} = \int_0^b (1) 1/EJ dx = [x]_0^b 1/EJ$$

$$= (b) 1/EJ = b/EJ$$

$$L_{FC}^{xx} = \int_0^b (1 - 2x/b + x^2/b^2) 1/EJ dx = [x - x^2/b + 1/3 x^3/b^2]_0^b 1/EJ$$

$$= (b - b + 1/3 b) 1/EJ = 1/3 b/EJ$$

$$L_{CF}^{xx} = \int_0^b (x^2/b^2) 1/EJ dx = [1/3 x^3/b^2]_0^b 1/EJ$$

$$= (1/3 b) 1/EJ = 1/3 b/EJ$$

$$L_{EF}^{xo} = \int_0^b (-5x/b) Fb 1/EJ dx + \int_0^b (1) \theta dx = [-5/2 x^2/b]_0^b Fb 1/EJ + [x]_0^b \theta$$

$$= (-5/2 b) Fb 1/EJ + (b) \theta = -3/2 Fb^2/EJ$$

$$L_{FE}^{xo} = \int_0^b (-5 + 5x/b) Fb 1/EJ dx + \int_0^b (-1) \theta dx = [-5x + 5/2 x^2/b]_0^b Fb 1/EJ + [-x]_0^b \theta$$

$$= (-5b + 5/2 b) Fb 1/EJ + (-b) \theta = -3/2 Fb^2/EJ$$

$$L_{FC}^{xo} = \int_0^b (-5 + 10x/b - 5x^2/b^2) Fb 1/EJ dx = [-5x + 5x^2/b - 5/3 x^3/b^2]_0^b Fb 1/EJ$$

$$= (-5b + 5b - 5/3 b) Fb 1/EJ = -5/3 Fb^2/EJ$$

$$L_{CF}^{xo} = \int_0^b (-5x^2/b^2) Fb 1/EJ dx = [-5/3 x^3/b^2]_0^b Fb 1/EJ$$

$$= (-5/3 b) Fb 1/EJ = -5/3 Fb^2/EJ$$

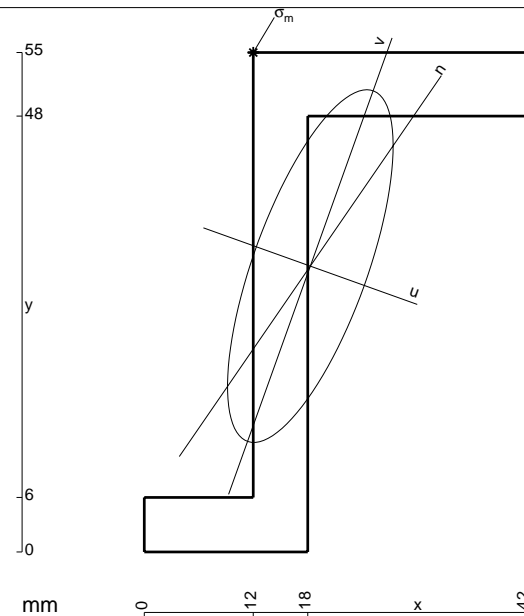

$$A = 570. \text{ mm}^2$$

$$J_x = 215051. \text{ mm}^4$$

$$J_y = 47402. \text{ mm}^4$$

$$J_{xy} = 68907. \text{ mm}^4$$

$$J_u = 239738. \text{ mm}^4$$

$$J_v = 22715. \text{ mm}^4$$

$$\alpha = \text{artg}(2J_{xy}/(J_y - J_x))/2 = -.3440$$

$$c = \cos \alpha = .9414$$

$$s = \sin \alpha = -.3373$$

$$x_g = 18.28 \text{ mm}$$

$$y_g = 31.48 \text{ mm}$$

$$N = -1850. \text{ N}$$

$$T_y = -1147. \text{ N}$$

$$M_x = 711140. \text{ Nmm}$$

$$x_m = 12. \text{ mm}$$

$$y_m = 55. \text{ mm}$$

$$u_m = -13.85 \text{ mm}$$

$$v_m = 20.02 \text{ mm}$$

$$\sigma_m = N/A - Mcv/J_u - Msu/J_v = -205.4 \text{ N/mm}^2$$

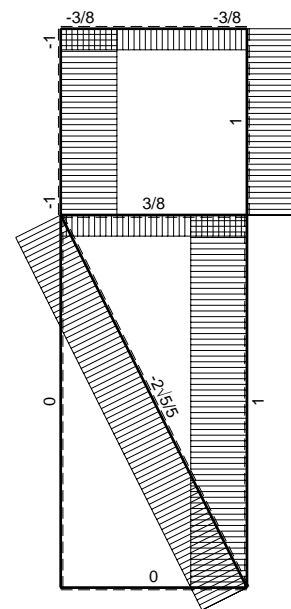
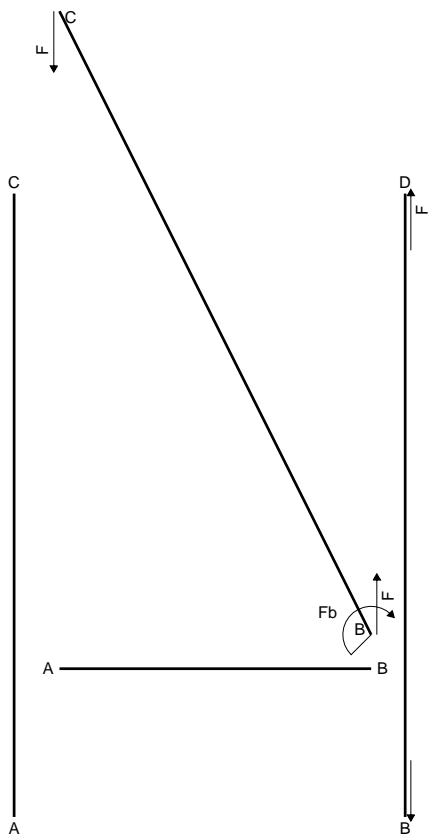
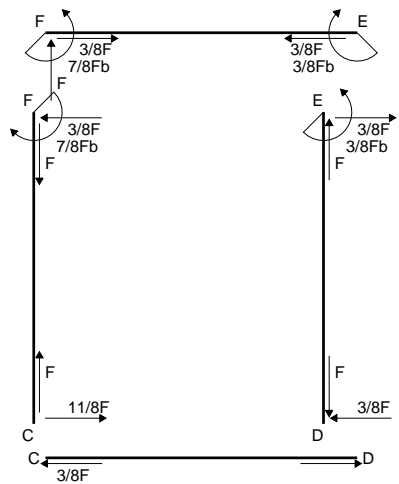

← ⊕ → F

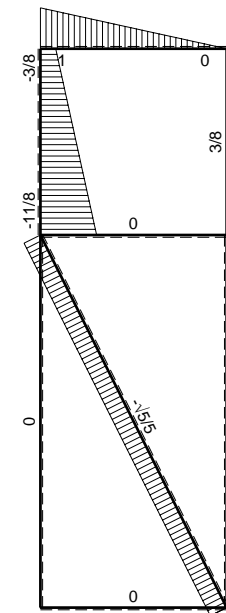

↑ ⊕ ↓ F

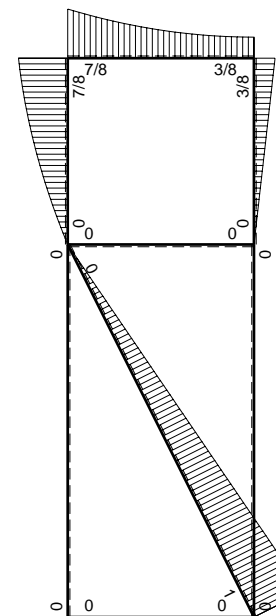

⊕ ⊖ Fb

$$L_{DE}^{xx} = \int_0^b (x^2/b^2) 1/EJ dx = [1/3 x^3/b^2]_0^b 1/EJ$$

$$= (1/3 b) 1/EJ = 1/3 b/EJ$$

$$L_{ED}^{xx} = \int_0^b (1 - 2x/b + x^2/b^2) 1/EJ dx = [x - x^2/b + 1/3 x^3/b^2]_0^b 1/EJ$$

$$= (b - b + 1/3 b) 1/EJ = 1/3 b/EJ$$

$$L_{EF}^{xx} = \int_0^b (1) 1/EJ dx = [x]_0^b 1/EJ$$

$$= (b) 1/EJ = b/EJ$$

$$L_{FE}^{xx} = \int_0^b (1) 1/EJ dx = [x]_0^b 1/EJ$$

$$= (b) 1/EJ = b/EJ$$

$$L_{FC}^{xx} = \int_0^b (1 - 2x/b + x^2/b^2) 1/EJ dx = [x - x^2/b + 1/3 x^3/b^2]_0^b 1/EJ$$

$$= (b - b + 1/3 b) 1/EJ = 1/3 b/EJ$$

$$L_{CF}^{xx} = \int_0^b (x^2/b^2) 1/EJ dx = [1/3 x^3/b^2]_0^b 1/EJ$$

$$= (1/3 b) 1/EJ = 1/3 b/EJ$$

$$L_{EF}^{xo} = \int_0^b (-1/2 x^2/b^2) Fb 1/EJ dx + \int_0^b (1) \theta dx = [-1/6 x^3/b^2]_0^b Fb 1/EJ + [x]_0^b \theta$$

$$= (-1/6 b) Fb 1/EJ + (b) \theta = 5/6 Fb^2/EJ$$

$$L_{FE}^{xo} = \int_0^b (-1/2 + x/b - 1/2 x^2/b^2) Fb 1/EJ dx + \int_0^b (-1) \theta dx$$

$$= [-1/2 x + 1/2 x^2/b - 1/6 x^3/b^2]_0^b Fb 1/EJ + [-x]_0^b \theta$$

$$= (-1/2 b + 1/2 b - 1/6 b) Fb 1/EJ + (-b) \theta = 5/6 Fb^2/EJ$$

$$L_{FC}^{xo} = \int_0^b (-1/2 + 1/2 x/b + 1/2 x^2/b^2 - 1/2 x^3/b^3) Fb 1/EJ dx$$

$$= [-1/2 x + 1/4 x^2/b + 1/6 x^3/b^2 - 1/8 x^4/b^3]_0^b Fb 1/EJ$$

$$= (-1/2 b + 1/4 b + 1/6 b - 1/8 b) Fb 1/EJ = -5/24 Fb^2/EJ$$

$$L_{CF}^{xo} = \int_0^b (-x^2/b^2 + 1/2 x^3/b^3) Fb 1/EJ dx = [-1/3 x^3/b^2 + 1/8 x^4/b^3]_0^b Fb 1/EJ$$

$$= (-1/3 b + 1/8 b) Fb 1/EJ = -5/24 Fb^2/EJ$$

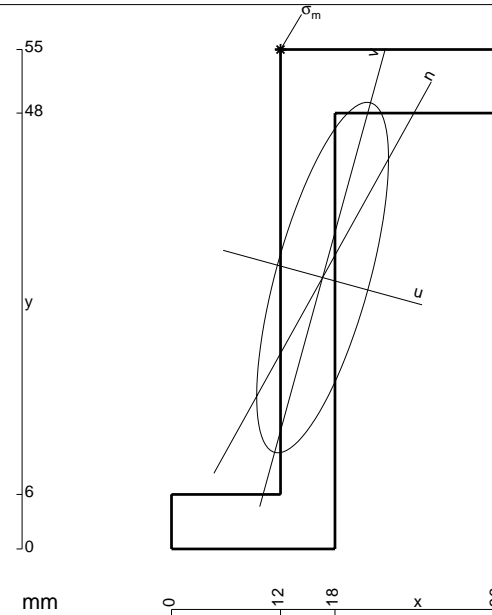

- A = 528. mm²
- J_x = 196705. mm⁴
- J_y = 27818. mm⁴
- J_{xy} = 50102. mm⁴
- J_u = 210450. mm⁴
- J_v = 14073. mm⁴
- α = artg(2J_{xy}/(J_y-J_x))/2 = -.2677
- c = cos α = .9644
- s = sin α = -.2646
- x_g = 16.64 mm
- y_g = 29.89 mm
- N = -939.1 N
- T_y = -469.6 N
- M_x = 693000. Nmm
- x_m = 12. mm
- y_m = 55. mm
- u_m = -11.12 mm
- v_m = 22.99 mm
- σ_m = N/A - Mc_v/J_u - Ms_u/J_v = -219.6 N/mm²

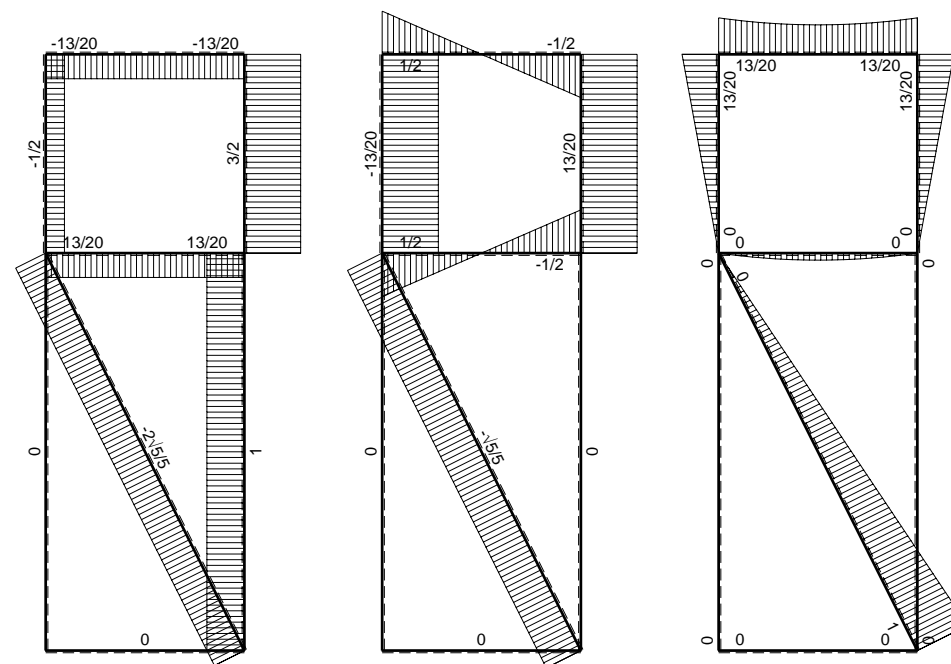
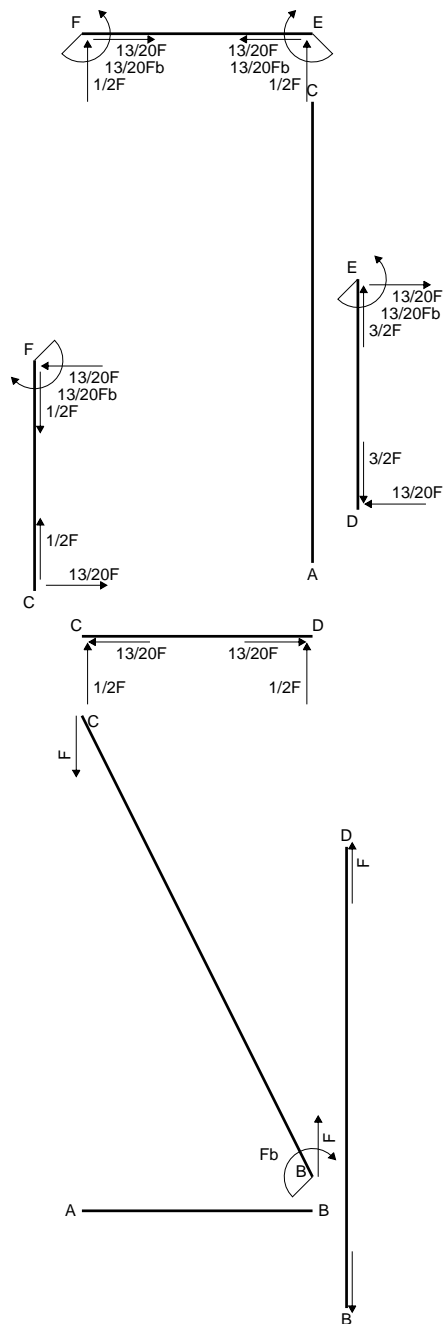

← ⊕ → F

↑ ⊕ ↓ F

⊕ ⊖ F_b

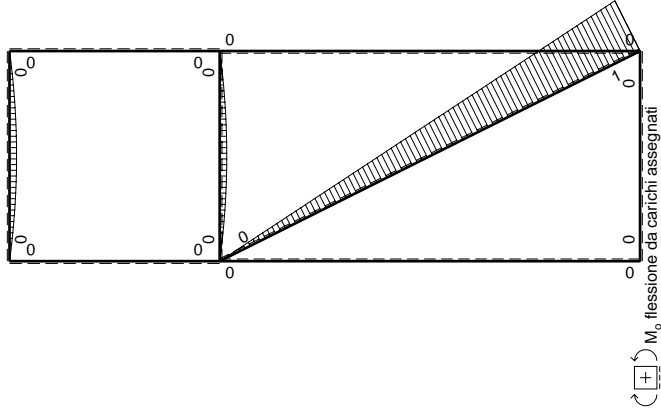
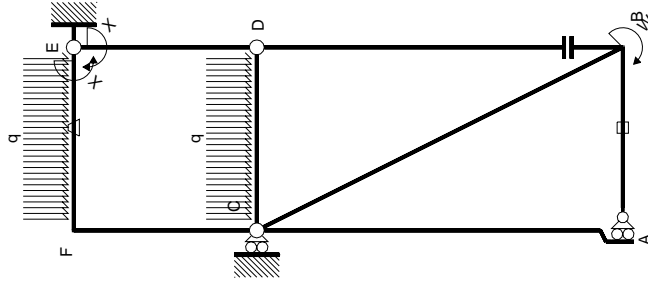

Sviluppi di calcolo iperstatica

Quadro contributi PLV per iperstatica $X=W_{EF}$

\leftarrow	$M^x(x)$	$M^0(x)$	θ	$M^x M_0$	$M^x \theta$	$M^x M_x$	$\int M^x (M_0/EJ + \theta) dx$	$\int M^x M_x / EJ dx$
AB b	0	0	0	0	0	0	0	0
BA b	0	0	0	0	0	0	0	0
BC $\sqrt{5}b$	0	$Fb - \sqrt{5}/5Fx$	0	0	0	0	0	0
AC 2b	0	0	0	0	0	0	0	0
CA 2b	0	0	0	0	0	0	0	0
DB 2b	0	0	0	0	0	0	0	0
BD 2b	0	0	0	0	0	0	0	0
DE b	-x/b	0	0	0	0	0	0	0
ED b	1-x/b	0	0	0	0	0	0	0
CD b	0	$1/2Fx - 1/2qx^2$	0	0	0	0	0	0
DC b	0	$-1/2Fx + 1/2qx^2$	0	0	0	0	0	0
EF b	-1	$-1/2Fx + 1/2qx^2$	$-Fb/EJ$	$1/2Fx - 1/2Fx^2/b$	Fb/EJ	1	$(1/12 + 1)Fb^2/EJ$	Xb/EJ
FE b	1	$1/2Fx - 1/2qx^2$	Fb/EJ	$1/2Fx - 1/2Fx^2/b$	Fb/EJ	1	$(1/12 + 1)Fb^2/EJ$	Xb/EJ
FC b	-1+x/b	0	0	0	0	0	0	0
CF b	x/b	0	0	0	0	0	0	0
totali							$13/12 Fb^2/EJ$	$5/3 Xb/EJ$
								$-13/20 Fb$

$$L_{DE}^{xx} = \int_0^b (x^2/b^2) 1/EJ dx = [1/3 x^3/b^2]_0^b 1/EJ$$

$$= (1/3 b) 1/EJ = 1/3 b/EJ$$

$$L_{ED}^{xx} = \int_0^b (1 - 2x/b + x^2/b^2) 1/EJ dx = [x - x^2/b + 1/3 x^3/b^2]_0^b 1/EJ$$

$$= (b - b + 1/3 b) 1/EJ = 1/3 b/EJ$$

$$L_{EF}^{xx} = \int_0^b (1) 1/EJ dx = [x]_0^b 1/EJ$$

$$= (b) 1/EJ = b/EJ$$

$$L_{FE}^{xx} = \int_0^b (1) 1/EJ dx = [x]_0^b 1/EJ$$

$$= (b) 1/EJ = b/EJ$$

$$L_{FC}^{xx} = \int_0^b (1 - 2x/b + x^2/b^2) 1/EJ dx = [x - x^2/b + 1/3 x^3/b^2]_0^b 1/EJ$$

$$= (b - b + 1/3 b) 1/EJ = 1/3 b/EJ$$

$$L_{CF}^{xx} = \int_0^b (x^2/b^2) 1/EJ dx = [1/3 x^3/b^2]_0^b 1/EJ$$

$$= (1/3 b) 1/EJ = 1/3 b/EJ$$

$$L_{EF}^{x\theta} = \int_0^b (1/2 x/b - 1/2 x^2/b^2) Fb 1/EJ dx + \int_0^b (1) \theta dx = [1/4 x^2/b - 1/6 x^3/b^2]_0^b Fb 1/EJ + [x]_0^b \theta$$

$$= (1/4 b - 1/6 b) Fb 1/EJ + (b) \theta = 13/12 Fb^2/EJ$$

$$L_{FE}^{x\theta} = \int_0^b (1/2 x/b - 1/2 x^2/b^2) Fb 1/EJ dx + \int_0^b (-1) \theta dx = [1/4 x^2/b - 1/6 x^3/b^2]_0^b Fb 1/EJ + [-x]_0^b \theta$$

$$= (1/4 b - 1/6 b) Fb 1/EJ + (-b) \theta = 13/12 Fb^2/EJ$$

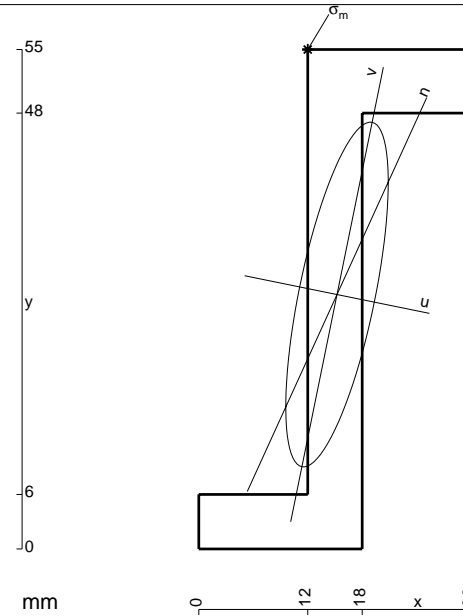

- A = 486. mm²
- J_x = 175218. mm⁴
- J_y = 15474. mm⁴
- J_{xy} = 33964. mm⁴
- J_u = 182139. mm⁴
- J_v = 8553. mm⁴
- α = artg(2J_{xy}/(J_y-J_x))/2 = -.2010
- c = cos α = .9799
- s = sin α = -.1997
- x_g = 15.22 mm
- y_g = 28.02 mm
- N = -858.7 N
- T_y = -429.3 N
- M_x = 672000. Nmm
- x_m = 12. mm
- y_m = 55. mm
- u_m = -8.545 mm
- v_m = 25.79 mm
- σ_m = N/A - Mcv/J_u - Msu/J_v = -229.1 N/mm²

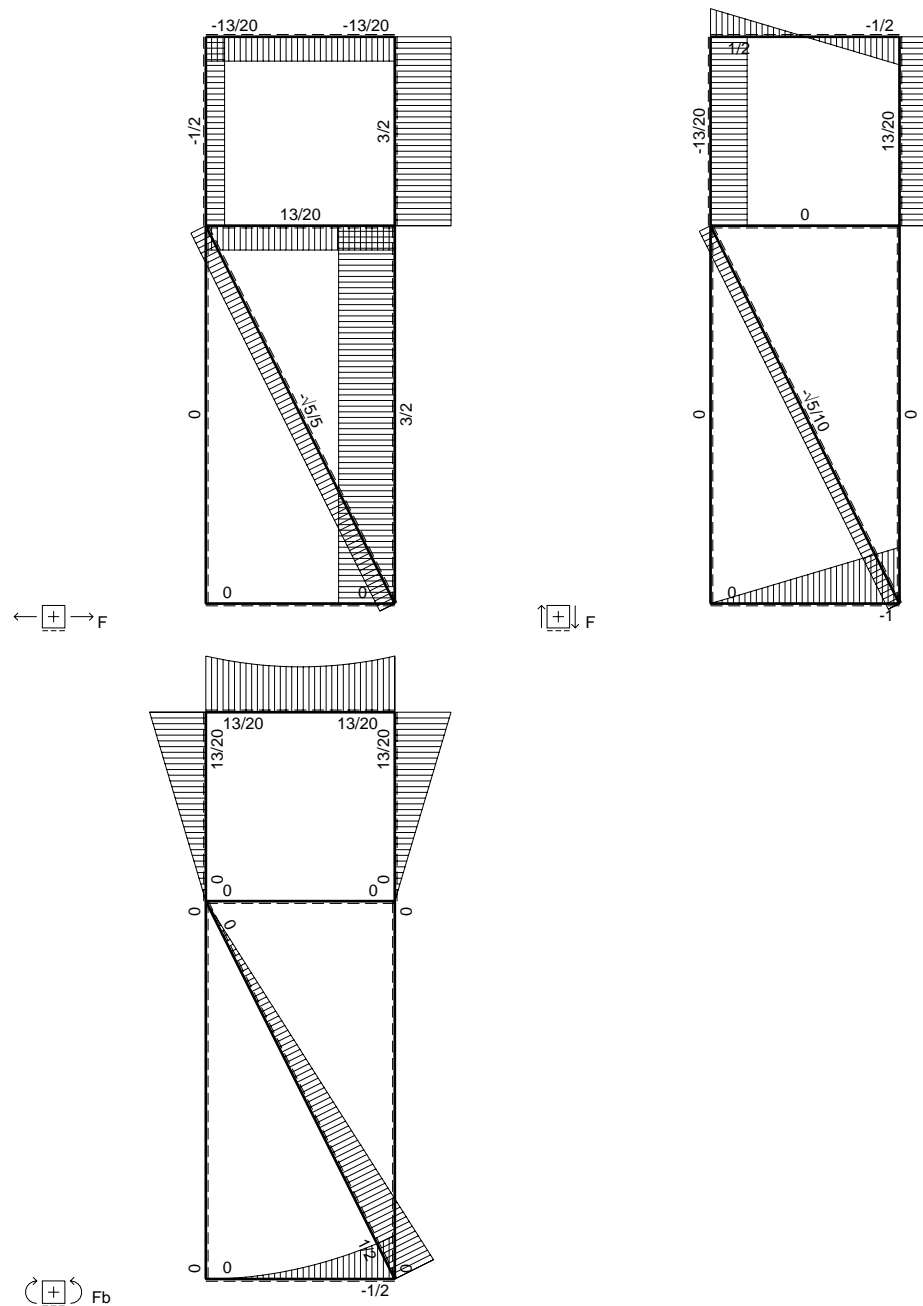
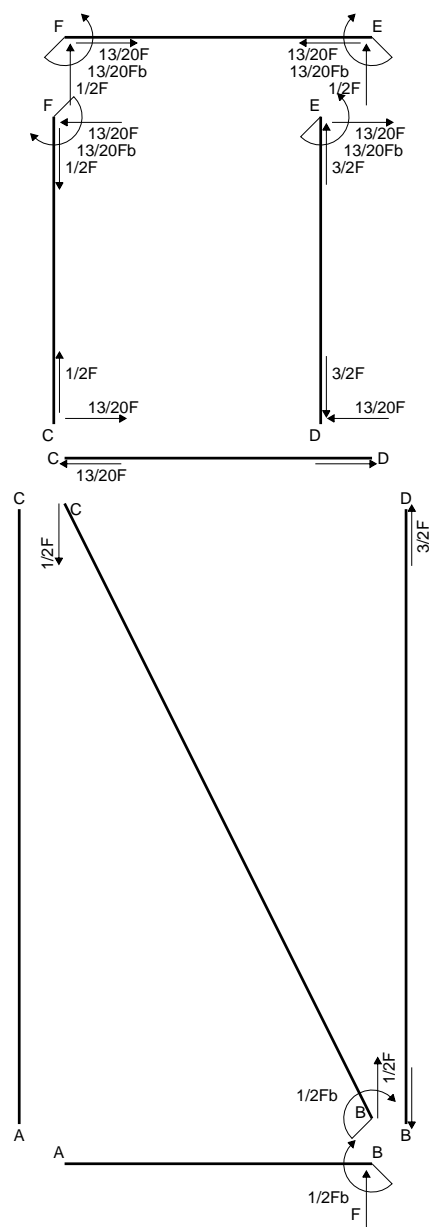

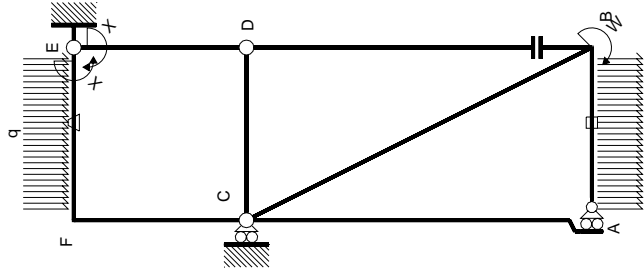

Schema di calcolo iperstatico

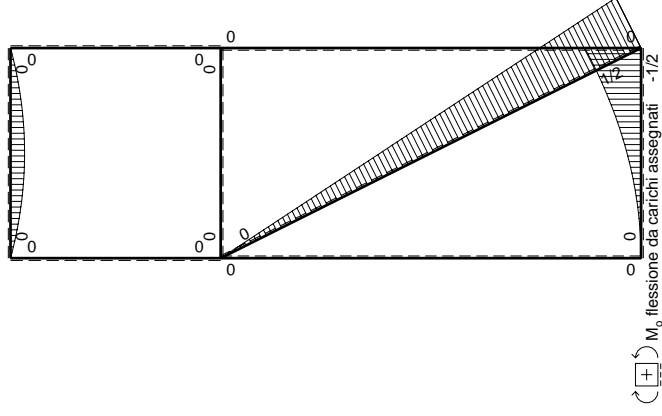

Quadro contributi PLV per iperstatica $X=W_{Ep}$

\rightarrow	$M_x(x)$	$M_0(x)$	θ	$M_x M_0$	$M_x \theta$	$M_x M_x$	$\int M_x(M_0/EJ+\theta)dx$	$\int M_x M_x/EJ dx$
AB b	0	$-1/2qx^2$	0	0	0	0	0	0
BA b	0	$1/2Fb-Fx+1/2qx^2$	0	0	0	0	0	0
BC $\sqrt{5}b$	0	$1/2Fb-\sqrt{5}/10Fx$	0	0	0	0	0	0
AC 2b	0	0	0	0	0	0	0	0
CA 2b	0	0	0	0	0	0	0	0
DB 2b	0	0	0	0	0	0	0	0
BD 2b	0	0	0	0	0	0	0	0
DE b	$-x/b$	0	0	0	0	0	x^2/b^2	$1/3xb/EJ$
ED b	$1-x/b$	0	0	0	0	0	$1-2x/b+x^2/b^2$	$1/3xb/EJ$
CD b	0	0	0	0	0	0	0	0
DC b	0	0	0	0	0	0	0	0
EF b	-1	$-1/2Fx+1/2qx^2$	$-Fb/EJ$	$1/2Fx-1/2Fx^2/b$	Fb/EJ	1	$(1/12+1)Fb^2/EJ$	Xb/EJ
FE b	1	$1/2Fx-1/2qx^2$	Fb/EJ	$1/2Fx-1/2Fx^2/b$	Fb/EJ	1	$(1/12+1)Fb^2/EJ$	Xb/EJ
FC b	$-1+x/b$	0	0	0	0	0	$1-2x/b+x^2/b^2$	$1/3xb/EJ$
CF b	x/b	0	0	0	0	0	x^2/b^2	$1/3xb/EJ$
totali							$13/12Fb^2/EJ$	$5/3xb/EJ$
								$-13/20Fb$

Sviluppi di calcolo iperstatica

M_x flessione da iperstatica $X=1$

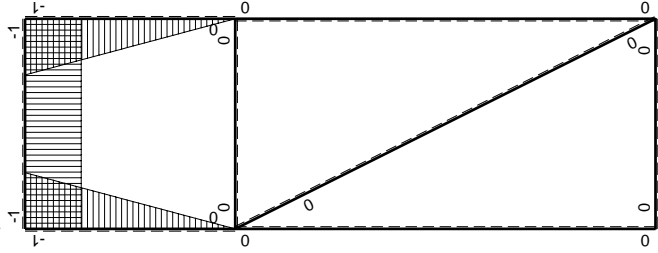

$$L_{DE}^{xx} = \int_0^b (x^2/b^2) 1/EJ dx = [1/3 x^3/b^2]_0^b 1/EJ$$

$$= (1/3 b) 1/EJ = 1/3 b/EJ$$

$$L_{ED}^{xx} = \int_0^b (1 - 2x/b + x^2/b^2) 1/EJ dx = [x - x^2/b + 1/3 x^3/b^2]_0^b 1/EJ$$

$$= (b - b + 1/3 b) 1/EJ = 1/3 b/EJ$$

$$L_{EF}^{xx} = \int_0^b (1) 1/EJ dx = [x]_0^b 1/EJ$$

$$= (b) 1/EJ = b/EJ$$

$$L_{FE}^{xx} = \int_0^b (1) 1/EJ dx = [x]_0^b 1/EJ$$

$$= (b) 1/EJ = b/EJ$$

$$L_{FC}^{xx} = \int_0^b (1 - 2x/b + x^2/b^2) 1/EJ dx = [x - x^2/b + 1/3 x^3/b^2]_0^b 1/EJ$$

$$= (b - b + 1/3 b) 1/EJ = 1/3 b/EJ$$

$$L_{CF}^{xx} = \int_0^b (x^2/b^2) 1/EJ dx = [1/3 x^3/b^2]_0^b 1/EJ$$

$$= (1/3 b) 1/EJ = 1/3 b/EJ$$

$$L_{EF}^{xo} = \int_0^b (1/2 x/b - 1/2 x^2/b^2) Fb 1/EJ dx + \int_0^b (1) \theta dx = [1/4 x^2/b - 1/6 x^3/b^2]_0^b Fb 1/EJ + [x]_0^b \theta$$

$$= (1/4 b - 1/6 b) Fb 1/EJ + (b) \theta = 13/12 Fb^2/EJ$$

$$L_{FE}^{xo} = \int_0^b (1/2 x/b - 1/2 x^2/b^2) Fb 1/EJ dx + \int_0^b (-1) \theta dx = [1/4 x^2/b - 1/6 x^3/b^2]_0^b Fb 1/EJ + [-x]_0^b \theta$$

$$= (1/4 b - 1/6 b) Fb 1/EJ + (-b) \theta = 13/12 Fb^2/EJ$$

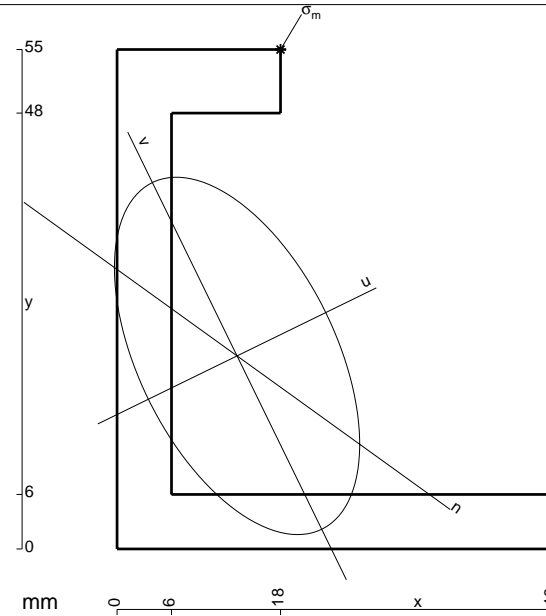

- A = 666. mm²
- J_x = 257974. mm⁴
- J_y = 121487. mm⁴
- J_{xy} = -87553. mm⁴
- J_u = 300738. mm⁴
- J_v = 78723. mm⁴
- α = arctg(2J_{xy}/(J_y-J_x))/2 = .4544
- c = cos α = .8985
- s = sin α = .4389
- x_g = 13.22 mm
- y_g = 21.26 mm
- N = -1677. N
- T_y = -1290. N
- M_x = 1240980. Nmm
- x_m = 18. mm
- y_m = 55. mm
- u_m = 19.11 mm
- v_m = 28.22 mm
- σ_m = N/A - Mc_v/J_u - Ms_u/J_v = -239.4 N/mm²

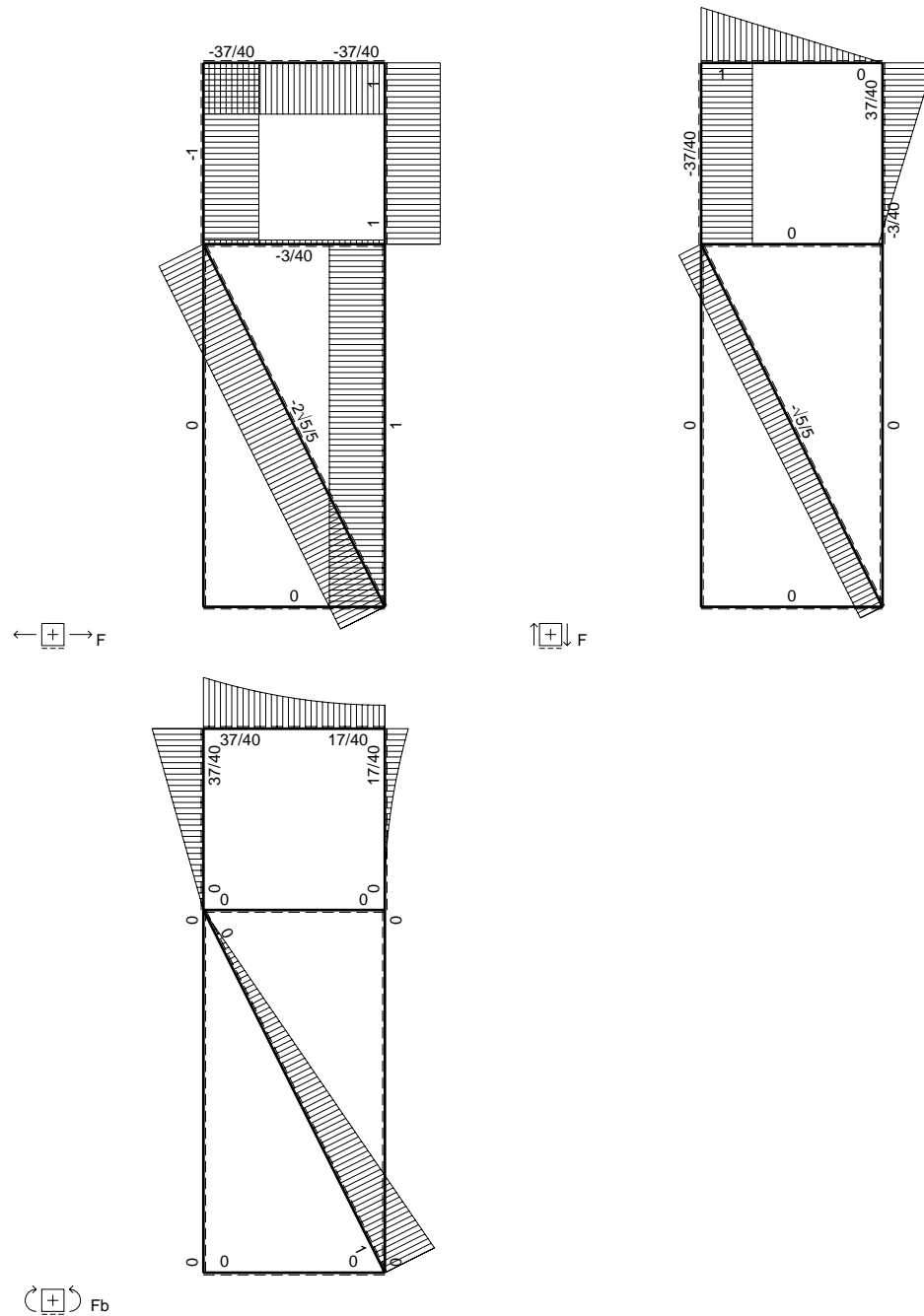
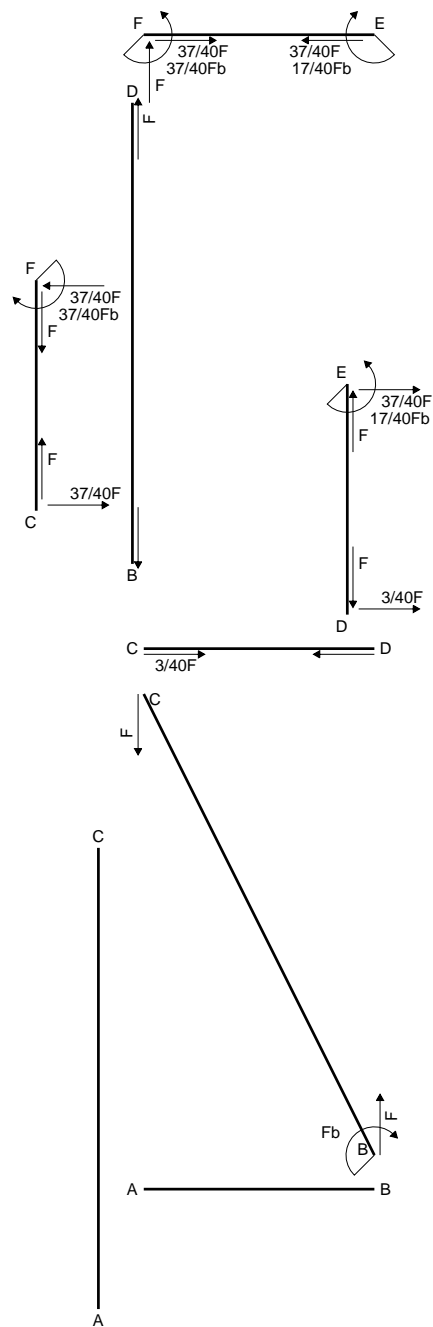

$$L_{DE}^{xx} = \int_0^b (x^2/b^2) 1/EJ dx = [1/3 x^3/b^2]_0^b 1/EJ$$

$$= (1/3 b) 1/EJ = 1/3 b/EJ$$

$$L_{ED}^{xx} = \int_0^b (1 - 2x/b + x^2/b^2) 1/EJ dx = [x - x^2/b + 1/3 x^3/b^2]_0^b 1/EJ$$

$$= (b - b + 1/3 b) 1/EJ = 1/3 b/EJ$$

$$L_{EF}^{xx} = \int_0^b (1) 1/EJ dx = [x]_0^b 1/EJ$$

$$= (b) 1/EJ = b/EJ$$

$$L_{FE}^{xx} = \int_0^b (1) 1/EJ dx = [x]_0^b 1/EJ$$

$$= (b) 1/EJ = b/EJ$$

$$L_{FC}^{xx} = \int_0^b (1 - 2x/b + x^2/b^2) 1/EJ dx = [x - x^2/b + 1/3 x^3/b^2]_0^b 1/EJ$$

$$= (b - b + 1/3 b) 1/EJ = 1/3 b/EJ$$

$$L_{CF}^{xx} = \int_0^b (x^2/b^2) 1/EJ dx = [1/3 x^3/b^2]_0^b 1/EJ$$

$$= (1/3 b) 1/EJ = 1/3 b/EJ$$

$$L_{DE}^{xo} = \int_0^b (1/2 x^2/b^2 - 1/2 x^3/b^3) Fb 1/EJ dx = [1/6 x^3/b^2 - 1/8 x^4/b^3]_0^b Fb 1/EJ$$

$$= (1/6 b - 1/8 b) Fb 1/EJ = 1/24 Fb^2/EJ$$

$$L_{ED}^{xo} = \int_0^b (1/2 x/b - x^2/b^2 + 1/2 x^3/b^3) Fb 1/EJ dx = [1/4 x^2/b - 1/3 x^3/b^2 + 1/8 x^4/b^3]_0^b Fb 1/EJ$$

$$= (1/4 b - 1/3 b + 1/8 b) Fb 1/EJ = 1/24 Fb^2/EJ$$

$$L_{EF}^{xo} = \int_0^b (-1/2 x^2/b^2) Fb 1/EJ dx + \int_0^b (1) \theta dx = [-1/6 x^3/b^2]_0^b Fb 1/EJ + [x]_0^b \theta$$

$$= (-1/6 b) Fb 1/EJ + (b) \theta = 5/6 Fb^2/EJ$$

$$L_{FE}^{xo} = \int_0^b (-1/2 + x/b - 1/2 x^2/b^2) Fb 1/EJ dx + \int_0^b (-1) \theta dx$$

$$= [-1/2 x + 1/2 x^2/b - 1/6 x^3/b^2]_0^b Fb 1/EJ + [-x]_0^b \theta$$

$$= (-1/2 b + 1/2 b - 1/6 b) Fb 1/EJ + (-b) \theta = 5/6 Fb^2/EJ$$

$$L_{FC}^{xo} = \int_0^b (-1/2 + x/b - 1/2 x^2/b^2) Fb 1/EJ dx = [-1/2 x + 1/2 x^2/b - 1/6 x^3/b^2]_0^b Fb 1/EJ$$

$$= (-1/2 b + 1/2 b - 1/6 b) Fb 1/EJ = -1/6 Fb^2/EJ$$

$$L_{CF}^{xo} = \int_0^b (-1/2 x^2/b^2) Fb 1/EJ dx = [-1/6 x^3/b^2]_0^b Fb 1/EJ$$

$$= (-1/6 b) Fb 1/EJ = -1/6 Fb^2/EJ$$

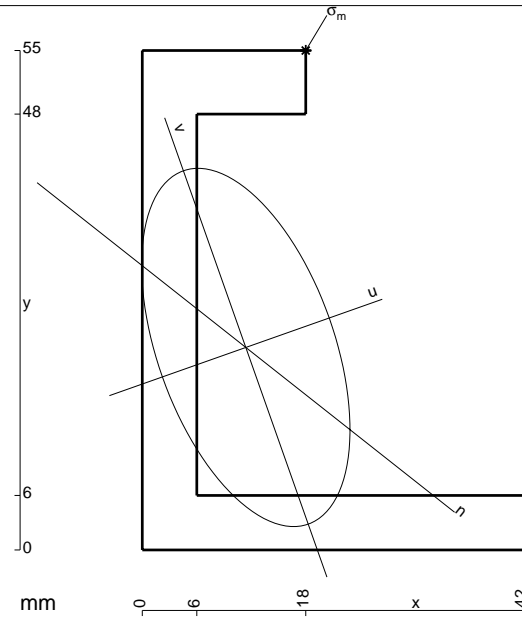

$$A = 630. \text{ mm}^2$$

$$J_x = 245181. \text{ mm}^4$$

$$J_y = 82933. \text{ mm}^4$$

$$J_{xy} = -65470. \text{ mm}^4$$

$$J_u = 268304. \text{ mm}^4$$

$$J_v = 59811. \text{ mm}^4$$

$$\alpha = \text{artg}(2J_{xy}/(J_y - J_x))/2 = .3395$$

$$c = \cos \alpha = .9429$$

$$s = \sin \alpha = .3330$$

$$x_g = 11.4 \text{ mm}$$

$$y_g = 22.3 \text{ mm}$$

$$N = -2290. \text{ N}$$

$$T_y = -1145. \text{ N}$$

$$M_x = 998400. \text{ Nmm}$$

$$x_m = 18. \text{ mm}$$

$$y_m = 55. \text{ mm}$$

$$u_m = 17.11 \text{ mm}$$

$$v_m = 28.64 \text{ mm}$$

$$\sigma_m = N/A - Mcv/J_u - Msu/J_v = -199.2 \text{ N/mm}^2$$

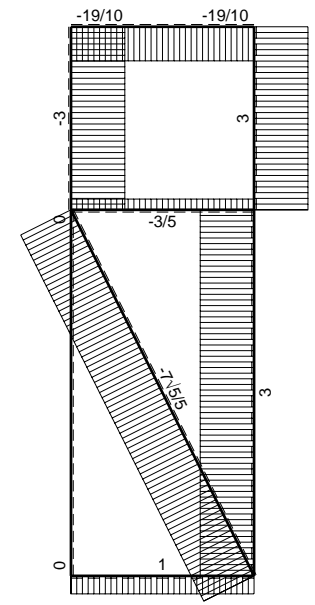
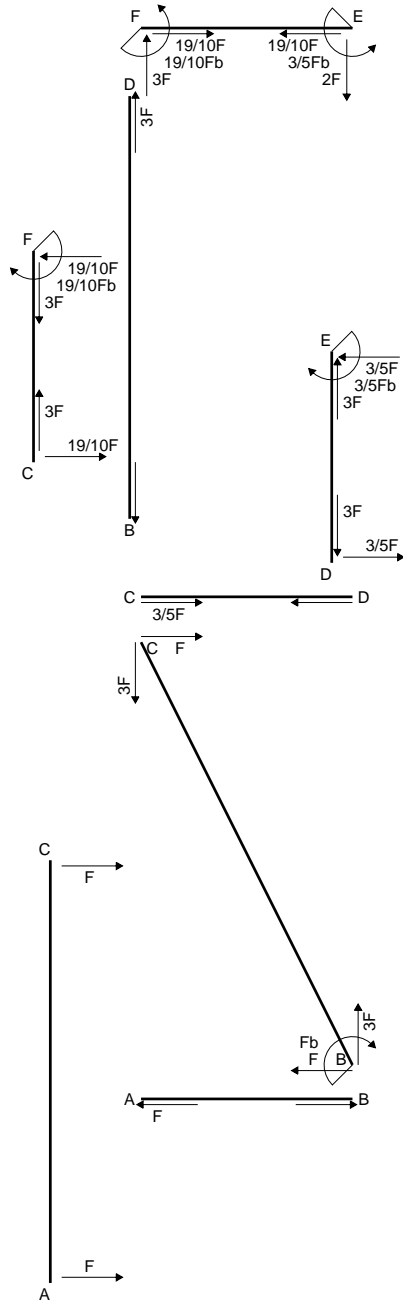

← ⊕ → F

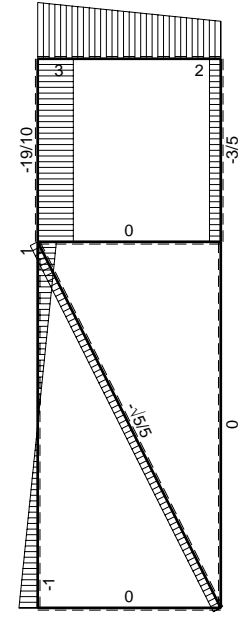

↑ ⊕ ↓ F

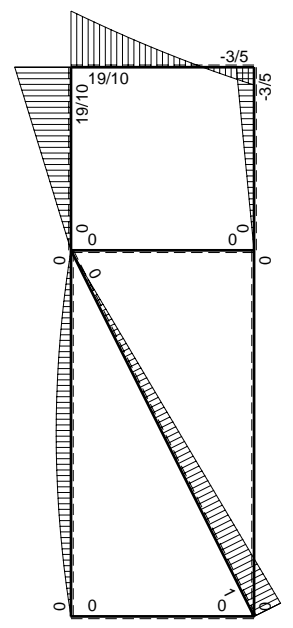

⊕ ⊖ F_b

$$L_{DE}^{xx} = \int_0^b (x^2/b^2) 1/EJ dx = [1/3 x^3/b^2]_0^b 1/EJ$$

$$= (1/3 b) 1/EJ = 1/3 b/EJ$$

$$L_{ED}^{xx} = \int_0^b (1 - 2x/b + x^2/b^2) 1/EJ dx = [x - x^2/b + 1/3 x^3/b^2]_0^b 1/EJ$$

$$= (b - b + 1/3 b) 1/EJ = 1/3 b/EJ$$

$$L_{EF}^{xx} = \int_0^b (1) 1/EJ dx = [x]_0^b 1/EJ$$

$$= (b) 1/EJ = b/EJ$$

$$L_{FE}^{xx} = \int_0^b (1) 1/EJ dx = [x]_0^b 1/EJ$$

$$= (b) 1/EJ = b/EJ$$

$$L_{FC}^{xx} = \int_0^b (1 - 2x/b + x^2/b^2) 1/EJ dx = [x - x^2/b + 1/3 x^3/b^2]_0^b 1/EJ$$

$$= (b - b + 1/3 b) 1/EJ = 1/3 b/EJ$$

$$L_{CF}^{xx} = \int_0^b (x^2/b^2) 1/EJ dx = [1/3 x^3/b^2]_0^b 1/EJ$$

$$= (1/3 b) 1/EJ = 1/3 b/EJ$$

$$L_{EF}^{xo} = \int_0^b (-2x/b - 1/2 x^2/b^2) Fb 1/EJ dx + \int_0^b (1) \theta dx = [-x^2/b - 1/6 x^3/b^2]_0^b Fb 1/EJ + [x]_0^b \theta$$

$$= (-b - 1/6 b) Fb 1/EJ + (b) \theta = -1/6 Fb^2/EJ$$

$$L_{FE}^{xo} = \int_0^b (-5/2 + 3x/b - 1/2 x^2/b^2) Fb 1/EJ dx + \int_0^b (-1) \theta dx$$

$$= [-5/2 x + 3/2 x^2/b - 1/6 x^3/b^2]_0^b Fb 1/EJ + [-x]_0^b \theta$$

$$= (-5/2 b + 3/2 b - 1/6 b) Fb 1/EJ + (-b) \theta = -1/6 Fb^2/EJ$$

$$L_{FC}^{xo} = \int_0^b (-5/2 + 5x/b - 5/2 x^2/b^2) Fb 1/EJ dx = [-5/2 x + 5/2 x^2/b - 5/6 x^3/b^2]_0^b Fb 1/EJ$$

$$= (-5/2 b + 5/2 b - 5/6 b) Fb 1/EJ = -5/6 Fb^2/EJ$$

$$L_{CF}^{xo} = \int_0^b (-5/2 x^2/b^2) Fb 1/EJ dx = [-5/6 x^3/b^2]_0^b Fb 1/EJ$$

$$= (-5/6 b) Fb 1/EJ = -5/6 Fb^2/EJ$$

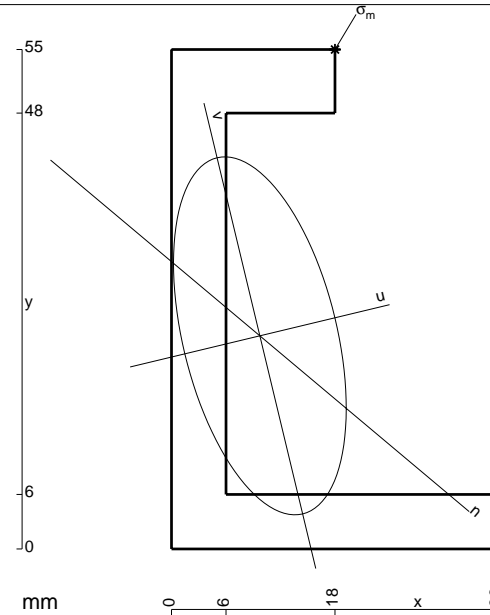

- A = 594. mm²
- J_x = 230851. mm⁴
- J_y = 53740. mm⁴
- J_{xy} = -45131. mm⁴
- J_u = 241688. mm⁴
- J_v = 42903. mm⁴
- α = arctg(2J_{xy}/(J_y-J_x))/2 = .2357
- c = cos α = .9724
- s = sin α = .2335
- x_g = 9.727 mm
- y_g = 23.47 mm
- N = -3810. N
- T_y = -2413. N
- M_x = 1013460. Nmm
- x_m = 18. mm
- y_m = 55. mm
- u_m = 15.41 mm
- v_m = 28.73 mm
- σ_m = N/A - Mc_v/J_u - Ms_u/J_v = -208.5 N/mm²

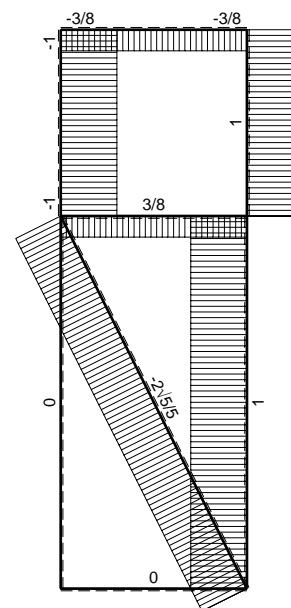
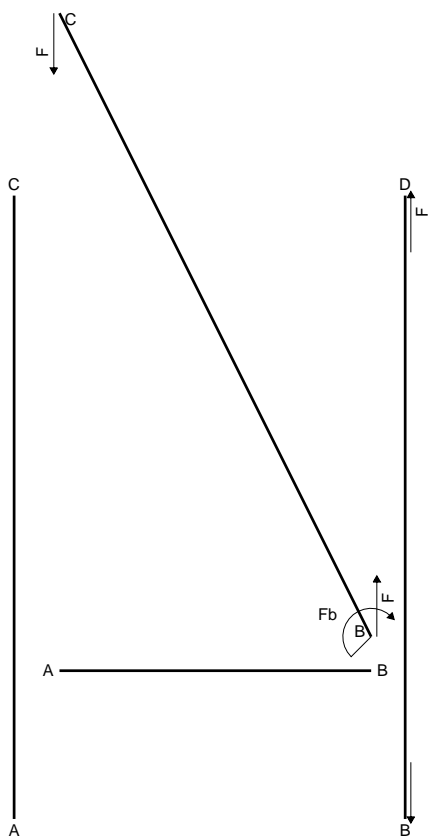
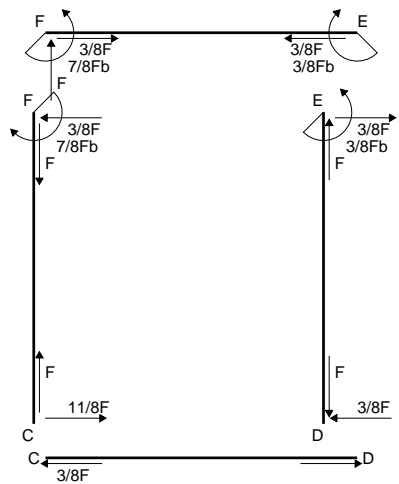

← ⊕ → F

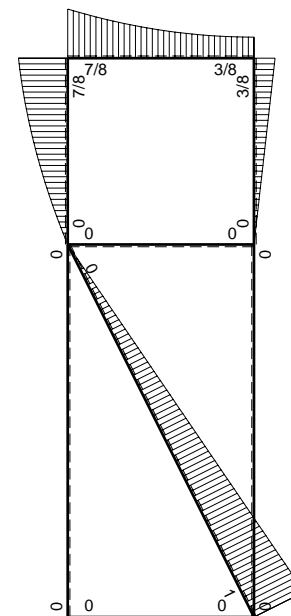

⊕ ⊖ Fb

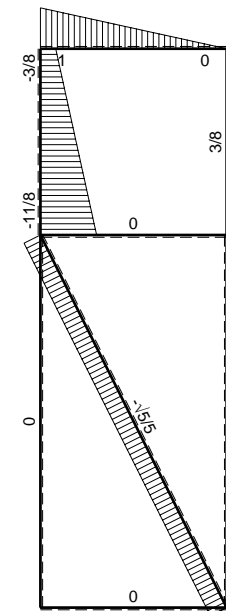

↑ ⊕ ↓ F

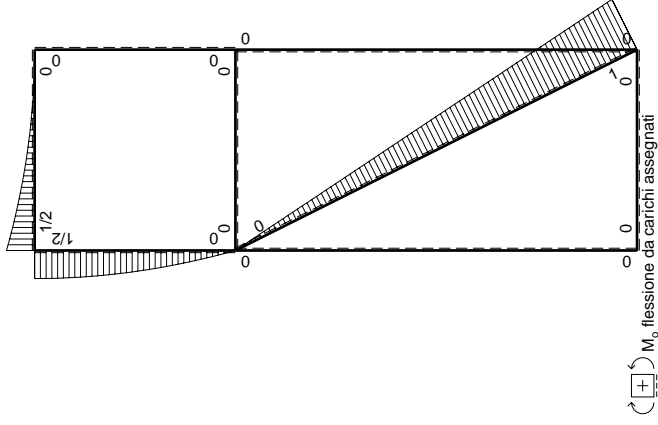
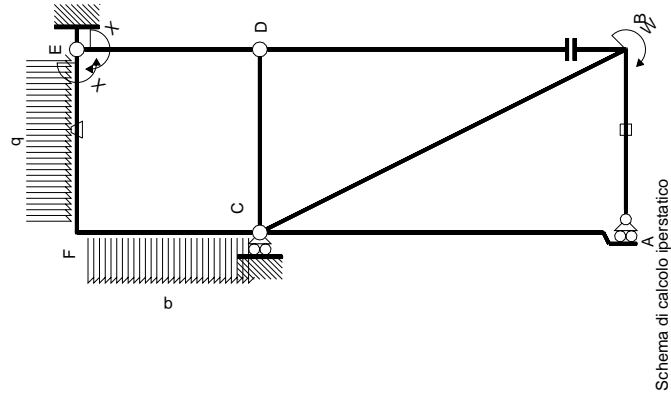

Quadro contributi PLV per iperstatica $X=W_{EF}$

\leftarrow	$M^x(x)$	$M_0(x)$	θ	$M^x M_0$	$M^x \theta$	$M^x M_x$	$\int M^x(M_0/EJ+\theta)dx$	$\int M^x M_x/EJdx$	AB	BA	BC	AC	CA	DB	BD	DE	ED	CD	DC	FE	FB	FC	CF	totali	iperstatica $X=W_{EF}$
0	0	0	0	0	0	0	0	0	0	0	0	0	0	0	0	0	0	0	0	1	-1	-1	-1	totali	-3/8Fb
0	0	0	0	0	0	0	0	0	0	0	0	0	0	0	0	0	0	0	0	1	-1	-1	-1	totali	5/8Fb ² /EJ
0	0	0	0	0	0	0	0	0	0	0	0	0	0	0	0	0	0	0	0	Fb/EJ	-Fb/EJ	-Fb/EJ	-Fb/EJ	totali	5/3Xb/EJ
0	0	0	0	0	0	0	0	0	0	0	0	0	0	0	0	0	0	0	0	Fb/EJ	-1/2Fb ² /b	-1/2Fb ² /b	-1/2Fb ² /b	totali	1/3Xb/EJ
0	0	0	0	0	0	0	0	0	0	0	0	0	0	0	0	0	0	0	0	Fb/EJ	-1/2Fb+Fx-1/2qx ²	-1/2Fb+Fx-1/2qx ²	-1/2Fb+Fx-1/2qx ²	totali	1/3Xb/EJ
0	0	0	0	0	0	0	0	0	0	0	0	0	0	0	0	0	0	0	0	Fb/EJ	-1/2Fb+1/2Fx+1/2qx ² /b-1/2qx ³ /b	-1/2Fb+1/2Fx+1/2qx ² /b-1/2qx ³ /b	-1/2Fb+1/2Fx+1/2qx ² /b-1/2qx ³ /b	totali	1/3Xb/EJ
0	0	0	0	0	0	0	0	0	0	0	0	0	0	0	0	0	0	0	0	0	0	0	0	totali	5/8Fb ² /EJ
0	0	0	0	0	0	0	0	0	0	0	0	0	0	0	0	0	0	0	0	0	0	0	0	totali	5/3Xb/EJ
$\int M^x(M_0/EJ+\theta)dx$	0	0	0	0	0	0	0	0	0	0	0	0	0	0	0	0	0	0	0	0	0	0	0	totali	-3/8Fb

Sviluppi di calcolo iperstatica

$$L_{DE}^{xx} = \int_0^b (x^2/b^2) 1/EJ dx = [1/3 x^3/b^2]_0^b 1/EJ$$

$$= (1/3 b) 1/EJ = 1/3 b/EJ$$

$$L_{ED}^{xx} = \int_0^b (1 - 2x/b + x^2/b^2) 1/EJ dx = [x - x^2/b + 1/3 x^3/b^2]_0^b 1/EJ$$

$$= (b - b + 1/3 b) 1/EJ = 1/3 b/EJ$$

$$L_{EF}^{xx} = \int_0^b (1) 1/EJ dx = [x]_0^b 1/EJ$$

$$= (b) 1/EJ = b/EJ$$

$$L_{FE}^{xx} = \int_0^b (1) 1/EJ dx = [x]_0^b 1/EJ$$

$$= (b) 1/EJ = b/EJ$$

$$L_{FC}^{xx} = \int_0^b (1 - 2x/b + x^2/b^2) 1/EJ dx = [x - x^2/b + 1/3 x^3/b^2]_0^b 1/EJ$$

$$= (b - b + 1/3 b) 1/EJ = 1/3 b/EJ$$

$$L_{CF}^{xx} = \int_0^b (x^2/b^2) 1/EJ dx = [1/3 x^3/b^2]_0^b 1/EJ$$

$$= (1/3 b) 1/EJ = 1/3 b/EJ$$

$$L_{EF}^{xo} = \int_0^b (-1/2 x^2/b^2) Fb 1/EJ dx + \int_0^b (1) \theta dx = [-1/6 x^3/b^2]_0^b Fb 1/EJ + [x]_0^b \theta$$

$$= (-1/6 b) Fb 1/EJ + (b) \theta = 5/6 Fb^2/EJ$$

$$L_{FE}^{xo} = \int_0^b (-1/2 + x/b - 1/2 x^2/b^2) Fb 1/EJ dx + \int_0^b (-1) \theta dx$$

$$= [-1/2 x + 1/2 x^2/b - 1/6 x^3/b^2]_0^b Fb 1/EJ + [-x]_0^b \theta$$

$$= (-1/2 b + 1/2 b - 1/6 b) Fb 1/EJ + (-b) \theta = 5/6 Fb^2/EJ$$

$$L_{FC}^{xo} = \int_0^b (-1/2 + 1/2 x/b + 1/2 x^2/b^2 - 1/2 x^3/b^3) Fb 1/EJ dx$$

$$= [-1/2 x + 1/4 x^2/b + 1/6 x^3/b^2 - 1/8 x^4/b^3]_0^b Fb 1/EJ$$

$$= (-1/2 b + 1/4 b + 1/6 b - 1/8 b) Fb 1/EJ = -5/24 Fb^2/EJ$$

$$L_{CF}^{xo} = \int_0^b (-x^2/b^2 + 1/2 x^3/b^3) Fb 1/EJ dx = [-1/3 x^3/b^2 + 1/8 x^4/b^3]_0^b Fb 1/EJ$$

$$= (-1/3 b + 1/8 b) Fb 1/EJ = -5/24 Fb^2/EJ$$

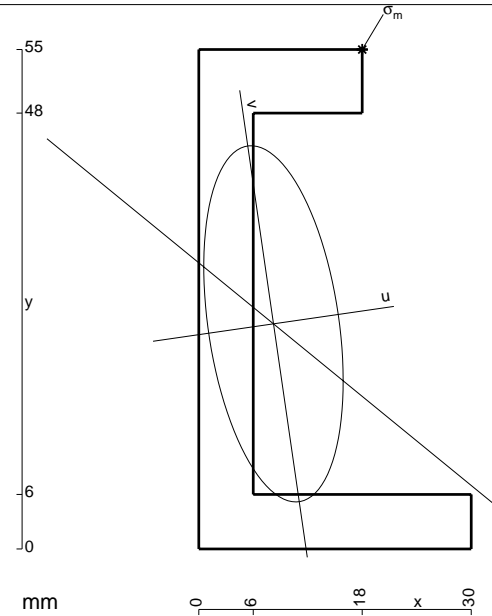

$$A = 558. \text{ mm}^2$$

$$J_x = 214685. \text{ mm}^4$$

$$J_y = 32876. \text{ mm}^4$$

$$J_{xy} = -26875. \text{ mm}^4$$

$$J_u = 218575. \text{ mm}^4$$

$$J_v = 28986. \text{ mm}^4$$

$$\alpha = \text{artg}(2J_{xy}/(J_y - J_x))/2 = .1437$$

$$c = \cos \alpha = .9897$$

$$s = \sin \alpha = .1432$$

$$x_g = 8.226 \text{ mm}$$

$$y_g = 24.79 \text{ mm}$$

$$N = -2120. \text{ N}$$

$$T_y = -1060. \text{ N}$$

$$M_x = 1090200. \text{ Nmm}$$

$$x_m = 18. \text{ mm}$$

$$y_m = 55. \text{ mm}$$

$$u_m = 14. \text{ mm}$$

$$v_m = 28.5 \text{ mm}$$

$$\sigma_m = N/A - Mcv/J_u - Msu/J_v = -219.9 \text{ N/mm}^2$$

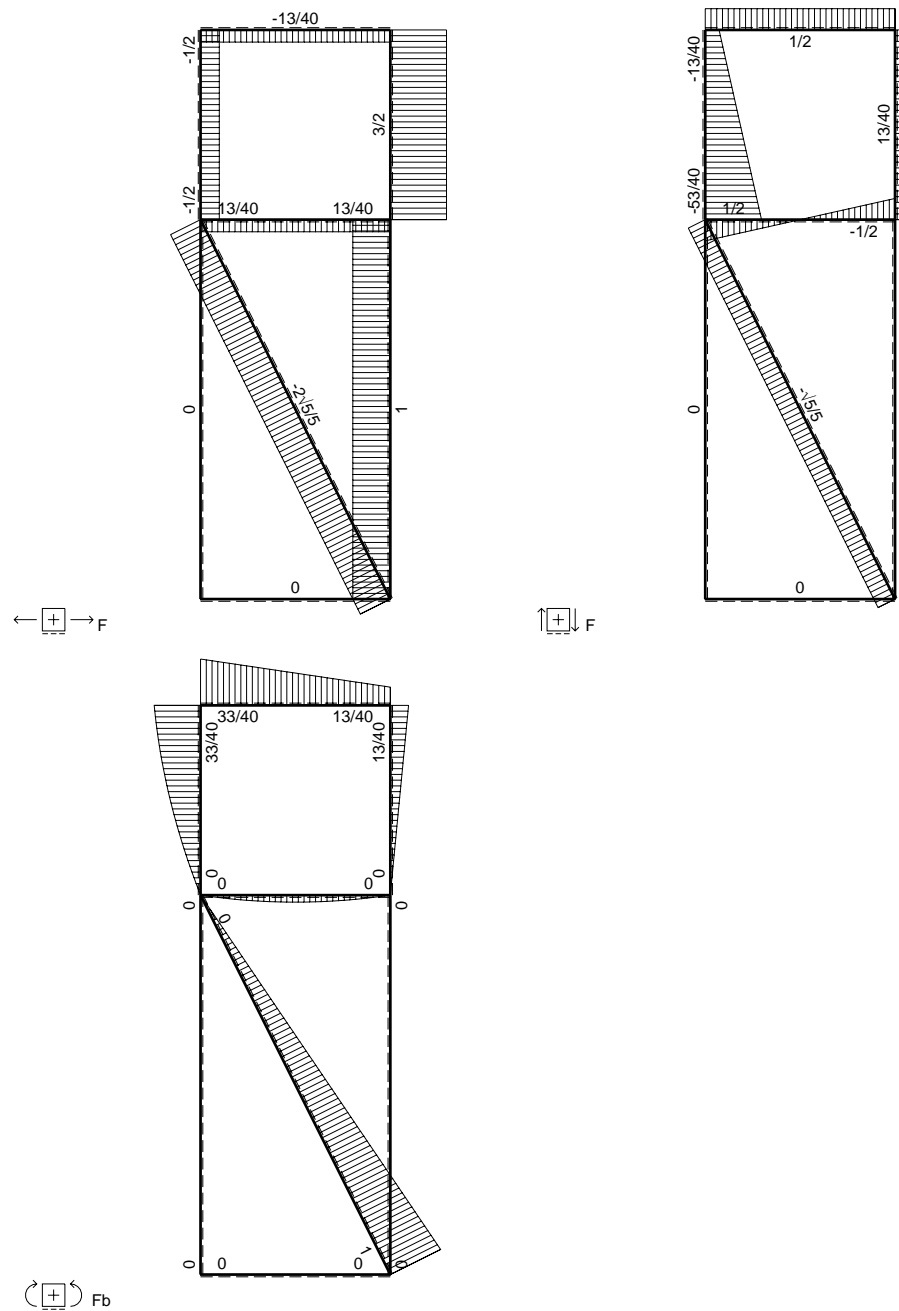
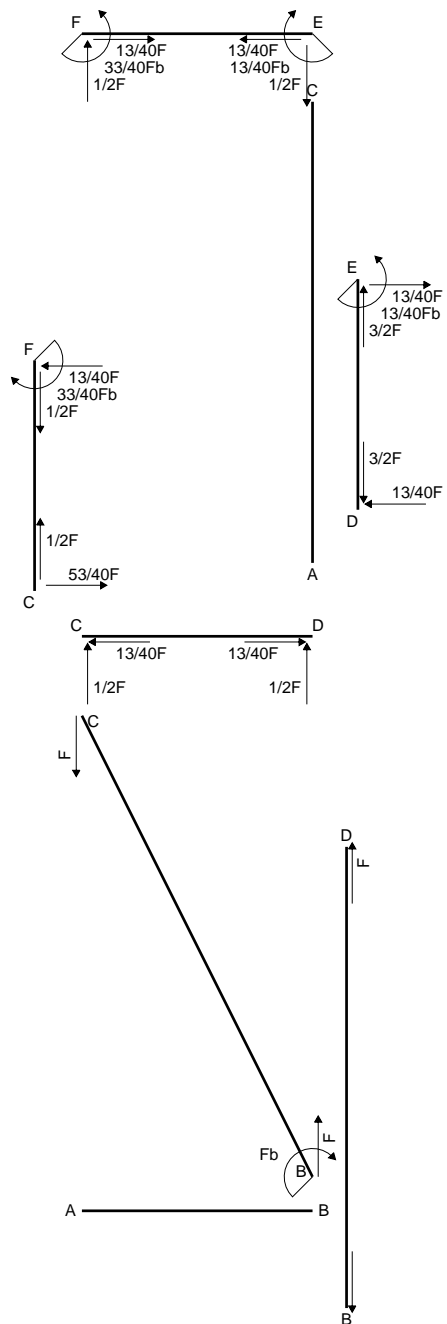

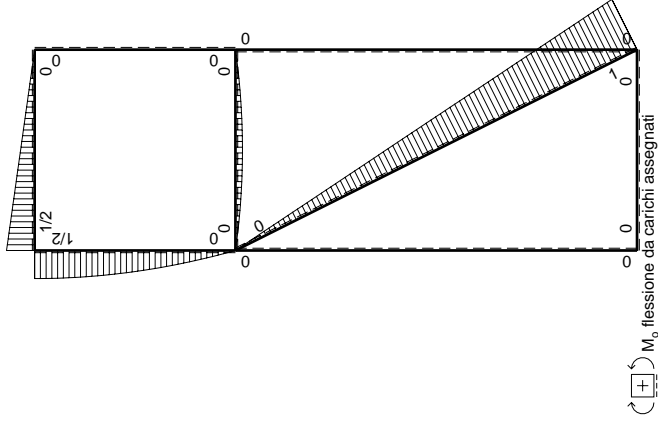
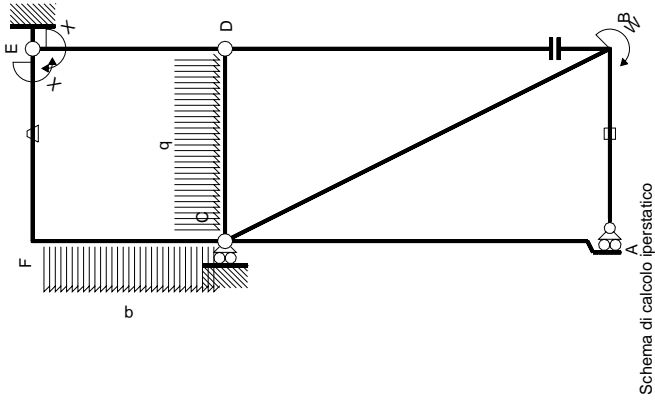

Quadro contributi PLV per iperstatica $X=W_{EP}$

←	$M(x)$	$M_0(x)$	θ	$M_x M_0$	$M_x \theta$	$M_x M_x$	$\int M_x(M_0/EJ+\theta)dx$	$\int M_x M_x/EJdx$
AB	0	0	0	0	0	0	0+0	0
BA	0	0	0	0	0	0	0	0
BC $\sqrt{5}b$	0	$Fb-\sqrt{5}Fx$	0	0	0	0	0	0
CA	0	0	0	0	0	0	0+0	0
AC	0	0	0	0	0	0	0	0
CB	0	0	0	0	0	0	0	0
DB	0	0	0	0	0	0	0+0	0
BD	0	0	0	0	0	0	0	0
DE	-x/b	0	0	0	0	0	0+0	1/3Xb/EJ
ED	1-x/b	0	0	0	0	0	0	1/3Xb/EJ
CD	0	$1/2Fx-1/2qx^2$	0	0	0	0	0	0
DC	0	$-1/2Fx+1/2qx^2$	0	0	0	0	0+0	0
EF	-1	1/2Fx	-Fb/EJ	-1/2Fx	Fb/EJ	1	1	Xb/EJ
FE	1	-1/2Fx	Fb/EJ	-1/2Fx	Fb/EJ	1	1	Xb/EJ
FC	-1+x/b	$1/2Fb-1/2qx^2$	0	$-1/2Fb+1/2Fx+1/2qx^3/b$	0	$1-2x/b+x^2/b^2$	x^2/b^2	1/3Xb/EJ
CF	x/b	$-Fx+1/2qx^2$	0	$-Fx^2/b+1/2qx^3/b$	0	x^2/b^2	x^2/b^2	1/3Xb/EJ
totali								5/3Xb/EJ
								13/24Fb ² /EJ
								-13/40Fb

Sviluppi di calcolo iperstatica

$$L_{DE}^{xx} = \int_0^b (x^2/b^2) 1/EJ dx = [1/3 x^3/b^2]_0^b 1/EJ$$

$$= (1/3 b) 1/EJ = 1/3 b/EJ$$

$$L_{ED}^{xx} = \int_0^b (1 - 2x/b + x^2/b^2) 1/EJ dx = [x - x^2/b + 1/3 x^3/b^2]_0^b 1/EJ$$

$$= (b - b + 1/3 b) 1/EJ = 1/3 b/EJ$$

$$L_{EF}^{xx} = \int_0^b (1) 1/EJ dx = [x]_0^b 1/EJ$$

$$= (b) 1/EJ = b/EJ$$

$$L_{FE}^{xx} = \int_0^b (1) 1/EJ dx = [x]_0^b 1/EJ$$

$$= (b) 1/EJ = b/EJ$$

$$L_{FC}^{xx} = \int_0^b (1 - 2x/b + x^2/b^2) 1/EJ dx = [x - x^2/b + 1/3 x^3/b^2]_0^b 1/EJ$$

$$= (b - b + 1/3 b) 1/EJ = 1/3 b/EJ$$

$$L_{CF}^{xx} = \int_0^b (x^2/b^2) 1/EJ dx = [1/3 x^3/b^2]_0^b 1/EJ$$

$$= (1/3 b) 1/EJ = 1/3 b/EJ$$

$$L_{EF}^{xo} = \int_0^b (-1/2 x/b) Fb 1/EJ dx + \int_0^b (1) \theta dx = [-1/4 x^2/b]_0^b Fb 1/EJ + [x]_0^b \theta$$

$$= (-1/4 b) Fb 1/EJ + (b) \theta = 3/4 Fb^2/EJ$$

$$L_{FE}^{xo} = \int_0^b (-1/2 + 1/2 x/b) Fb 1/EJ dx + \int_0^b (-1) \theta dx = [-1/2 x + 1/4 x^2/b]_0^b Fb 1/EJ + [-x]_0^b \theta$$

$$= (-1/2 b + 1/4 b) Fb 1/EJ + (-b) \theta = 3/4 Fb^2/EJ$$

$$L_{FC}^{xo} = \int_0^b (-1/2 + 1/2 x/b + 1/2 x^2/b^2 - 1/2 x^3/b^3) Fb 1/EJ dx$$

$$= [-1/2 x + 1/4 x^2/b + 1/6 x^3/b^2 - 1/8 x^4/b^3]_0^b Fb 1/EJ$$

$$= (-1/2 b + 1/4 b + 1/6 b - 1/8 b) Fb 1/EJ = -5/24 Fb^2/EJ$$

$$L_{CF}^{xo} = \int_0^b (-x^2/b^2 + 1/2 x^3/b^3) Fb 1/EJ dx = [-1/3 x^3/b^2 + 1/8 x^4/b^3]_0^b Fb 1/EJ$$

$$= (-1/3 b + 1/8 b) Fb 1/EJ = -5/24 Fb^2/EJ$$

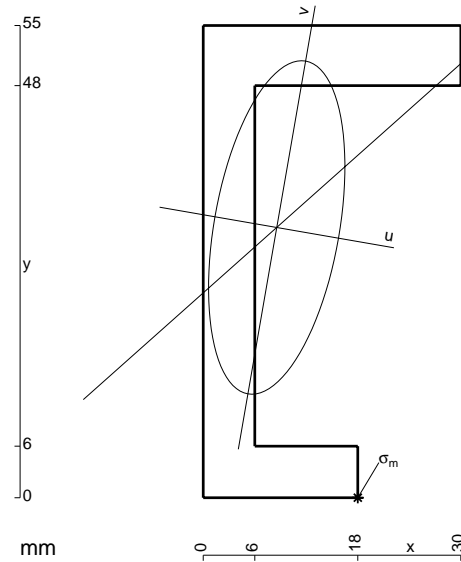

- A = 570. mm²
- J_x = 215051. mm⁴
- J_y = 35943. mm⁴
- J_{xy} = 31999. mm⁴
- J_u = 220596. mm⁴
- J_v = 30398. mm⁴
- α = arctg(2J_{xy}/(J_y-J_x))/2 = -.1716
- c = cos α = .9853
- s = sin α = -.1707
- x_g = 8.558 mm
- y_g = 31.48 mm
- N = -1950. N
- T_y = -974.9 N
- M_x = 1090000. Nmm
- x_m = 18. mm
- u_m = 14.68 mm
- v_m = -29.4 mm
- σ_m = N/A - Mcv/J_u - Msu/J_v = 229.6 N/mm²

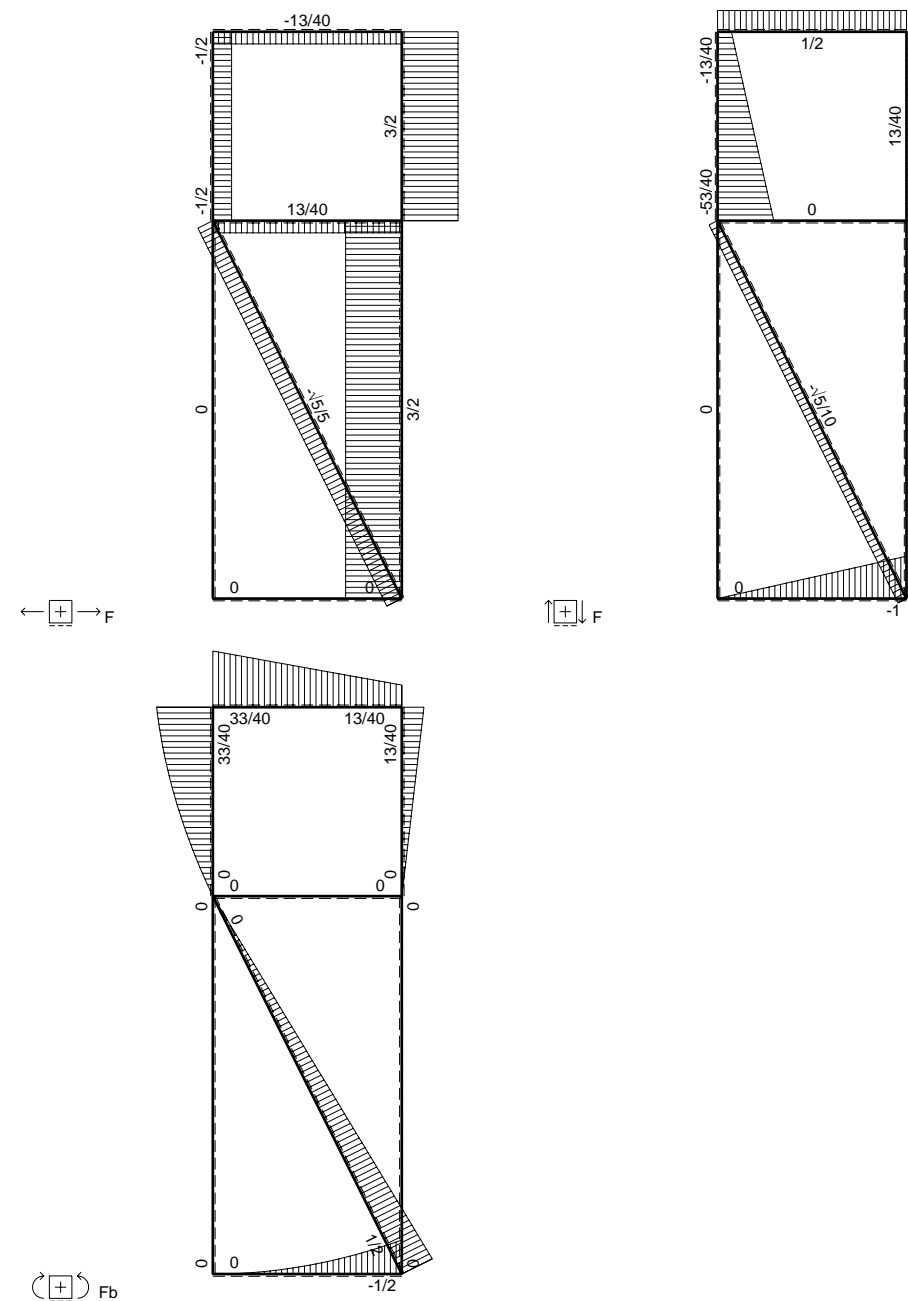
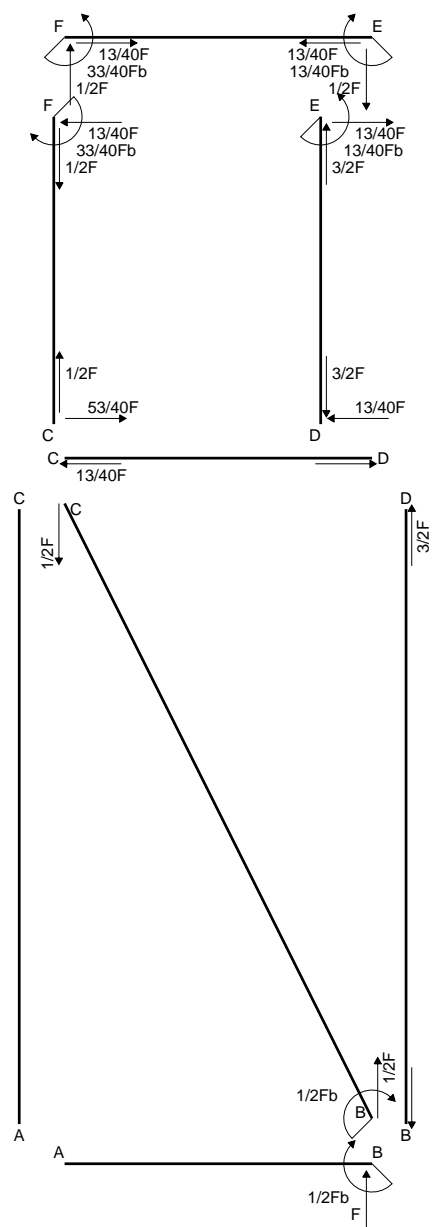

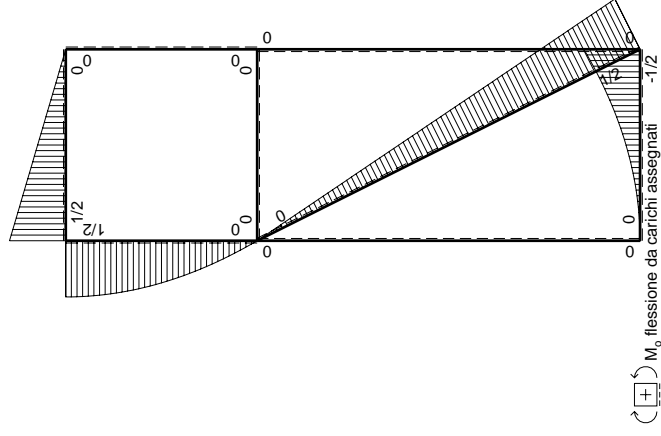
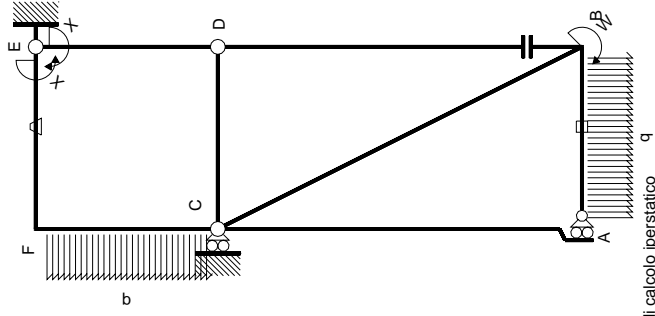

M_x flessione da iperstatica $X=1$

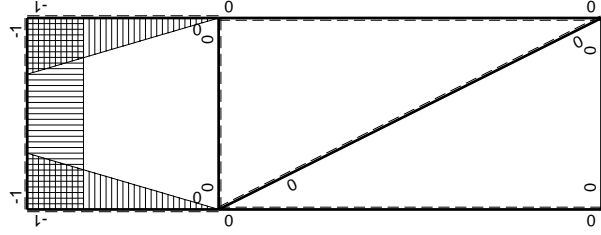

Quadro contributi PLV per iperstatica $X=W_{EF}$

\rightarrow	$M^x(x)$	$M^0(x)$	θ	$M^x M_0$	$M^x \theta$	$M^x M_x$	$\int M^x (M_0/EJ + \theta) dx$	$\int M^x M_x / E dx$
AB b	0	$-1/2qx^2$	0	0	0	0	0	0
BA b	0	$1/2Fb - Fx + 1/2qx^2$	0	0	0	0	0	0
BC $\sqrt{5}b$	0	$1/2Fb - \sqrt{5}/10Fx$	0	0	0	0	0	0
AC 2b	0	0	0	0	0	0	0	0
CA 2b	0	0	0	0	0	0	0	0
DB 2b	0	0	0	0	0	0	0	0
BD 2b	0	0	0	0	0	0	0	0
DE b	$-x/b$	0	0	0	0	x^2/b^2	0	0
ED b	$1-x/b$	0	0	0	0	$1-2x/b+x^2/b^2$	0	$1/3Xb/EJ$
CD b	0	0	0	0	0	0	0	0
DC b	0	0	0	0	0	0	0	0
EF b	-1	$1/2Fx$	$-Fb/EJ$	$-1/2Fx$	Fb/EJ	1	1	Xb/EJ
FE b	1	$-1/2Fb + 1/2Fx$	Fb/EJ	$-1/2Fb + 1/2Fx$	Fb/EJ	1	$(-1/4+1)Fb^2/EJ$	$1/3Xb/EJ$
FC b	$-1+x/b$	$1/2Fb - 1/2qx^2$	0	$-1/2Fb + 1/2Fx + 1/2Fx^2/b - 1/2qx^3/b$	0	$1-2x/b+x^2/b^2$	$(-5/24+0)Fb^2/EJ$	$1/3Xb/EJ$
CF b	x/b	$-Fx + 1/2qx^2$	0	$-Fx^2/b + 1/2qx^3/b$	0	x^2/b^2	$13/24Fb^2/EJ$	$5/3Xb/EJ$
totali								
iperstatica $X=W_{EF}$								

Sviluppi di calcolo iperstatica

$$L_{DE}^{xx} = \int_0^b (x^2/b^2) 1/EJ dx = [1/3 x^3/b^2]_0^b 1/EJ$$

$$= (1/3 b) 1/EJ = 1/3 b/EJ$$

$$L_{ED}^{xx} = \int_0^b (1 - 2x/b + x^2/b^2) 1/EJ dx = [x - x^2/b + 1/3 x^3/b^2]_0^b 1/EJ$$

$$= (b - b + 1/3 b) 1/EJ = 1/3 b/EJ$$

$$L_{EF}^{xx} = \int_0^b (1) 1/EJ dx = [x]_0^b 1/EJ$$

$$= (b) 1/EJ = b/EJ$$

$$L_{FE}^{xx} = \int_0^b (1) 1/EJ dx = [x]_0^b 1/EJ$$

$$= (b) 1/EJ = b/EJ$$

$$L_{FC}^{xx} = \int_0^b (1 - 2x/b + x^2/b^2) 1/EJ dx = [x - x^2/b + 1/3 x^3/b^2]_0^b 1/EJ$$

$$= (b - b + 1/3 b) 1/EJ = 1/3 b/EJ$$

$$L_{CF}^{xx} = \int_0^b (x^2/b^2) 1/EJ dx = [1/3 x^3/b^2]_0^b 1/EJ$$

$$= (1/3 b) 1/EJ = 1/3 b/EJ$$

$$L_{EF}^{xo} = \int_0^b (-1/2 x/b) Fb 1/EJ dx + \int_0^b (1) \theta dx = [-1/4 x^2/b]_0^b Fb 1/EJ + [x]_0^b \theta$$

$$= (-1/4 b) Fb 1/EJ + (b) \theta = 3/4 Fb^2/EJ$$

$$L_{FE}^{xo} = \int_0^b (-1/2 + 1/2 x/b) Fb 1/EJ dx + \int_0^b (-1) \theta dx = [-1/2 x + 1/4 x^2/b]_0^b Fb 1/EJ + [-x]_0^b \theta$$

$$= (-1/2 b + 1/4 b) Fb 1/EJ + (-b) \theta = 3/4 Fb^2/EJ$$

$$L_{FC}^{xo} = \int_0^b (-1/2 + 1/2 x/b + 1/2 x^2/b^2 - 1/2 x^3/b^3) Fb 1/EJ dx$$

$$= [-1/2 x + 1/4 x^2/b + 1/6 x^3/b^2 - 1/8 x^4/b^3]_0^b Fb 1/EJ$$

$$= (-1/2 b + 1/4 b + 1/6 b - 1/8 b) Fb 1/EJ = -5/24 Fb^2/EJ$$

$$L_{CF}^{xo} = \int_0^b (-x^2/b^2 + 1/2 x^3/b^3) Fb 1/EJ dx = [-1/3 x^3/b^2 + 1/8 x^4/b^3]_0^b Fb 1/EJ$$

$$= (-1/3 b + 1/8 b) Fb 1/EJ = -5/24 Fb^2/EJ$$

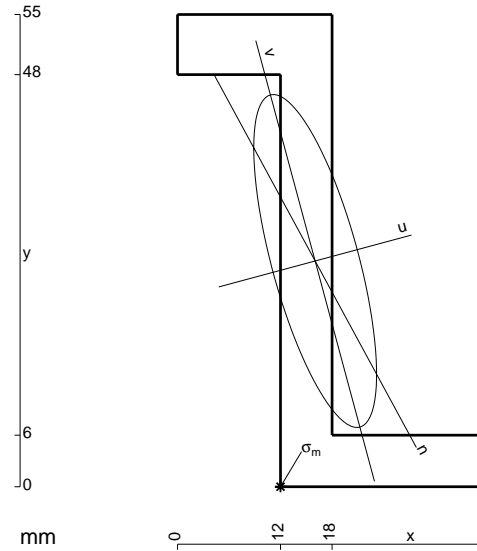

$$A = 522. \text{ mm}^2$$

$$J_x = 196305. \text{ mm}^4$$

$$J_y = 26711. \text{ mm}^4$$

$$J_{xy} = -49244. \text{ mm}^4$$

$$J_u = 209567. \text{ mm}^4$$

$$J_v = 13450. \text{ mm}^4$$

$$\alpha = \text{artg}(2J_{xy}/(J_y - J_x))/2 = .2631$$

$$c = \cos \alpha = .9656$$

$$s = \sin \alpha = .2600$$

$$x_g = 16.03 \text{ mm}$$

$$y_g = 26.29 \text{ mm}$$

$$N = -549.3 \text{ N}$$

$$T_y = 845. \text{ N}$$

$$M_x = 752895. \text{ Nmm}$$

$$x_m = 12. \text{ mm}$$

$$u_m = -10.73 \text{ mm}$$

$$v_m = -24.34 \text{ mm}$$

$$\sigma_m = N/A - Mcv/J_u - Msu/J_v = 239.6 \text{ N/mm}^2$$

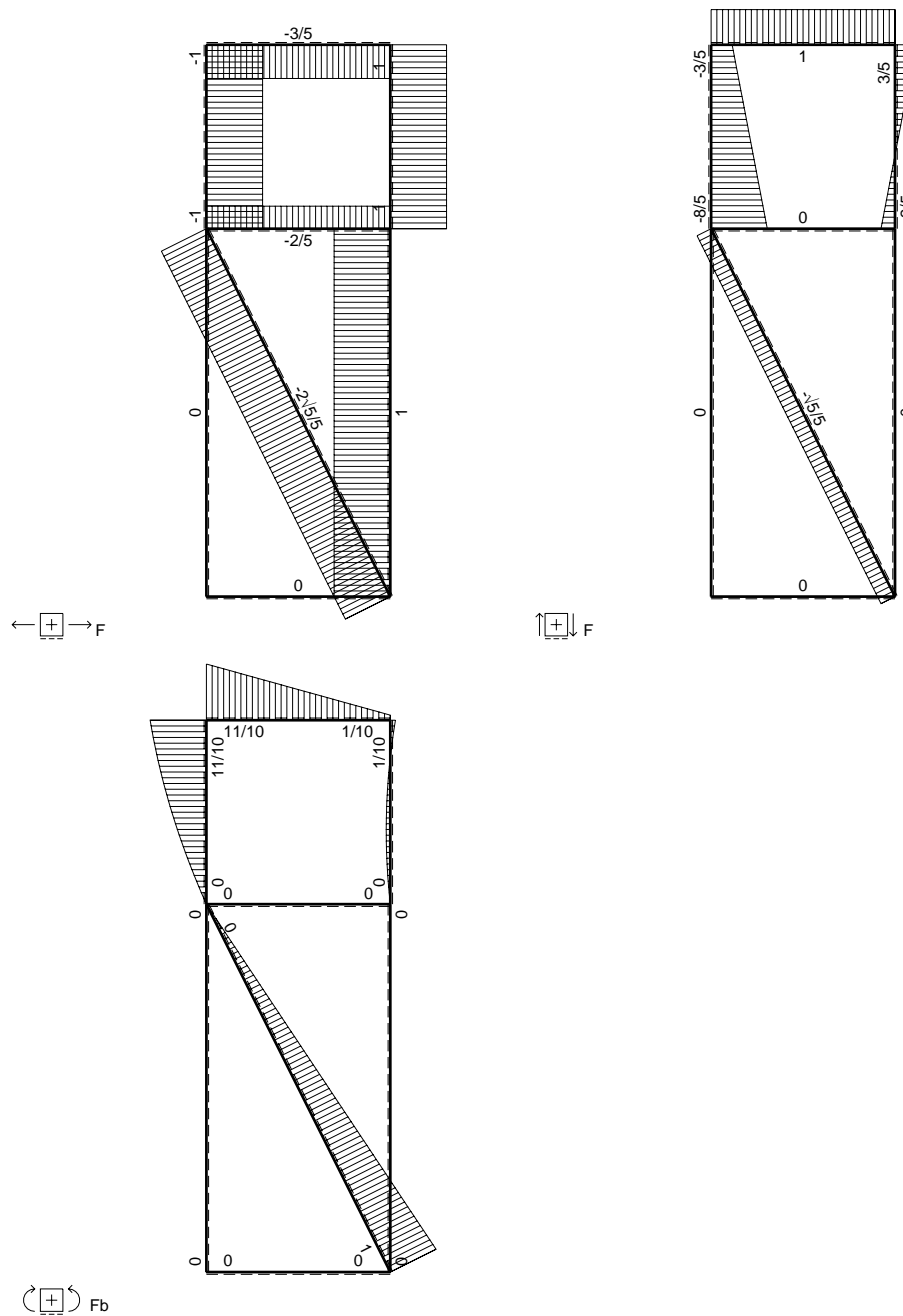
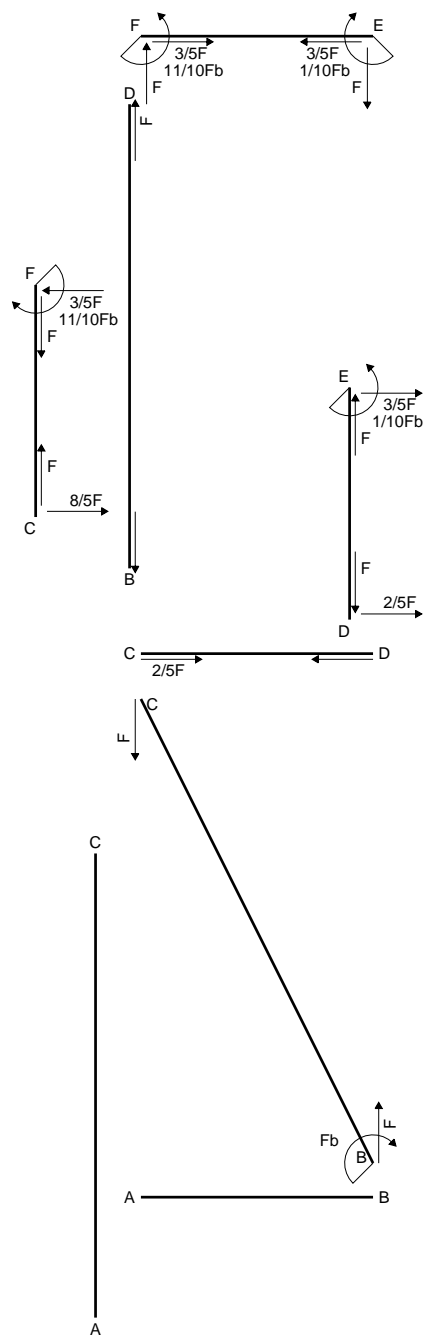

\oplus Fb

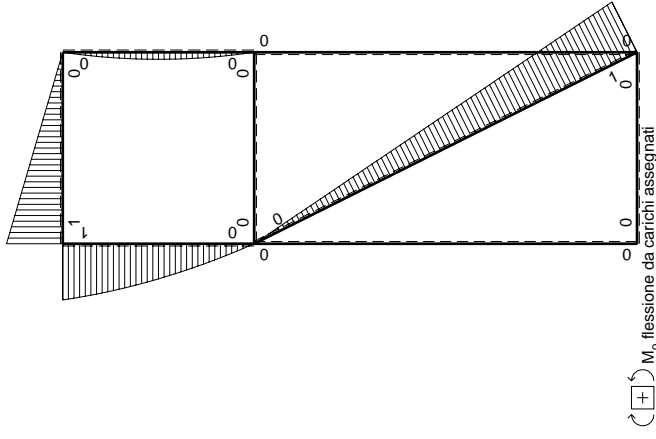
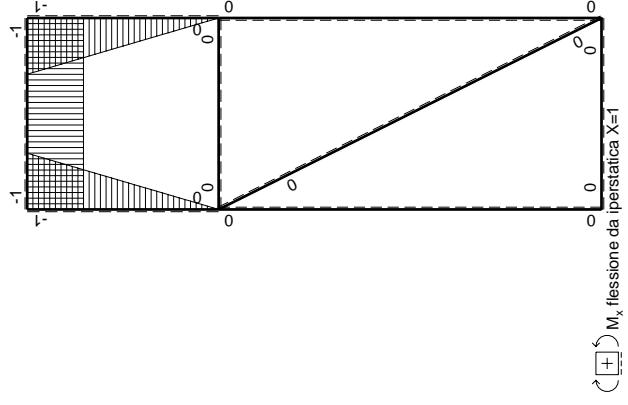
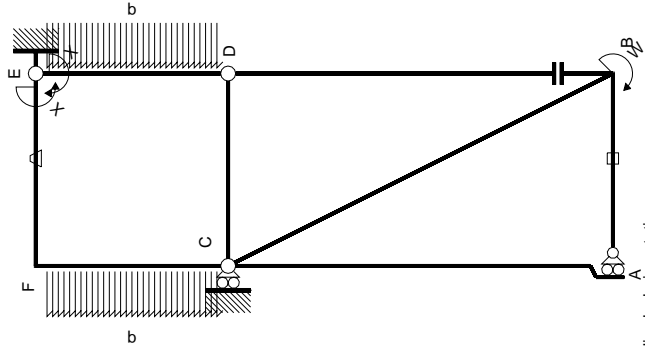

←	$M(x)$		$M_0(x)$		M_θ		M_x		$\int M_x(M_0/EJ+\theta)dx$		$\int M_x M_0/EJ dx$		
	AB	BC	CA	DB	BD	DE	ED	CD	DC	FE	FC	CF	
AB	0	0	0	0	0	0	0	0	0+0	0	0	0	
BA	0	0	0	0	0	0	0	0	0	0	0	0	
BC	0	$Fb-\sqrt{5}/5Fx$	0	0	0	0	0	0	0+0	0	0	0	
CA	0	0	0	0	0	0	0	0	0+0	0	0	0	
DB	0	0	0	0	0	0	0	0	0+0	0	0	0	
BD	0	0	0	0	0	0	0	0	0+0	0	0	0	
DE	$-x/b$	$-1/2Fx+1/2qx^2$	0	$1/2Fx^2/b-1/2qx^3/b$	0	$1/2Fx^2/b+1/2qx^3/b$	0	x^2/b^2	$(1/24+0)Fb^2/EJ$	$1/3xb/EJ$	0	0	
ED	$1-x/b$	$1/2Fx-1/2qx^2$	0	$1/2Fx-Fx^2/b+1/2qx^3/b$	0	$1-2x/b+x^2/b^2$	0	x^2/b^2	$(1/24+0)Fb^2/EJ$	$1/3xb/EJ$	0	0	
CD	0	0	0	0	0	0	0	0	0+0	0	0	0	
DC	0	0	0	0	0	0	0	0	0+0	0	0	0	
FE	-1	Fx	$-Fb/EJ$	$-Fx$	Fb/EJ	1	$(-1/2+1)Fb^2/EJ$	x^2/b^2	$(-3/8+0)Fb^2/EJ$	$1/3xb/EJ$	0	0	
FC	$-1+x/b$	$-Fb+Fx$	Fb/EJ	$-Fb+Fx$	Fb/EJ	1	x^2/b^2	$(-3/8+0)Fb^2/EJ$	$1/3xb/EJ$	0	0	0	
CF	x/b	$-3/2Fx+1/2qx^2$	0	$-Fb+3/2Fx-1/2qx^3/b$	0	$1-2x/b+x^2/b^2$	0	x^2/b^2	$(-3/8+0)Fb^2/EJ$	$1/3xb/EJ$	0	0	
totali													

Quadro contributi PLV per iperstatica $X=W_{EF}$

Sviluppi di calcolo iperstatica

$$L_{DE}^{xx} = \int_0^b (x^2/b^2) 1/EJ dx = [1/3 x^3/b^2]_0^b 1/EJ$$

$$= (1/3 b) 1/EJ = 1/3 b/EJ$$

$$L_{ED}^{xx} = \int_0^b (1 - 2x/b + x^2/b^2) 1/EJ dx = [x - x^2/b + 1/3 x^3/b^2]_0^b 1/EJ$$

$$= (b - b + 1/3 b) 1/EJ = 1/3 b/EJ$$

$$L_{EF}^{xx} = \int_0^b (1) 1/EJ dx = [x]_0^b 1/EJ$$

$$= (b) 1/EJ = b/EJ$$

$$L_{FE}^{xx} = \int_0^b (1) 1/EJ dx = [x]_0^b 1/EJ$$

$$= (b) 1/EJ = b/EJ$$

$$L_{FC}^{xx} = \int_0^b (1 - 2x/b + x^2/b^2) 1/EJ dx = [x - x^2/b + 1/3 x^3/b^2]_0^b 1/EJ$$

$$= (b - b + 1/3 b) 1/EJ = 1/3 b/EJ$$

$$L_{CF}^{xx} = \int_0^b (x^2/b^2) 1/EJ dx = [1/3 x^3/b^2]_0^b 1/EJ$$

$$= (1/3 b) 1/EJ = 1/3 b/EJ$$

$$L_{DE}^{xo} = \int_0^b (1/2 x^2/b^2 - 1/2 x^3/b^3) Fb 1/EJ dx = [1/6 x^3/b^2 - 1/8 x^4/b^3]_0^b Fb 1/EJ$$

$$= (1/6 b - 1/8 b) Fb 1/EJ = 1/24 Fb^2/EJ$$

$$L_{ED}^{xo} = \int_0^b (1/2 x/b - x^2/b^2 + 1/2 x^3/b^3) Fb 1/EJ dx = [1/4 x^2/b - 1/3 x^3/b^2 + 1/8 x^4/b^3]_0^b Fb 1/EJ$$

$$= (1/4 b - 1/3 b + 1/8 b) Fb 1/EJ = 1/24 Fb^2/EJ$$

$$L_{EF}^{xo} = \int_0^b (-x/b) Fb 1/EJ dx + \int_0^b (1) \theta dx = [-1/2 x^2/b]_0^b Fb 1/EJ + [x]_0^b \theta$$

$$= (-1/2 b) Fb 1/EJ + (b) \theta = 1/2 Fb^2/EJ$$

$$L_{FE}^{xo} = \int_0^b (-1 + x/b) Fb 1/EJ dx + \int_0^b (-1) \theta dx = [-x + 1/2 x^2/b]_0^b Fb 1/EJ + [-x]_0^b \theta$$

$$= (-b + 1/2 b) Fb 1/EJ + (-b) \theta = 1/2 Fb^2/EJ$$

$$L_{FC}^{xo} = \int_0^b (-1 + 3/2 x/b - 1/2 x^3/b^3) Fb 1/EJ dx = [-x + 3/4 x^2/b - 1/8 x^4/b^3]_0^b Fb 1/EJ$$

$$= (-b + 3/4 b - 1/8 b) Fb 1/EJ = -3/8 Fb^2/EJ$$

$$L_{CF}^{xo} = \int_0^b (-3/2 x^2/b^2 + 1/2 x^3/b^3) Fb 1/EJ dx = [-1/2 x^3/b^2 + 1/8 x^4/b^3]_0^b Fb 1/EJ$$

$$= (-1/2 b + 1/8 b) Fb 1/EJ = -3/8 Fb^2/EJ$$

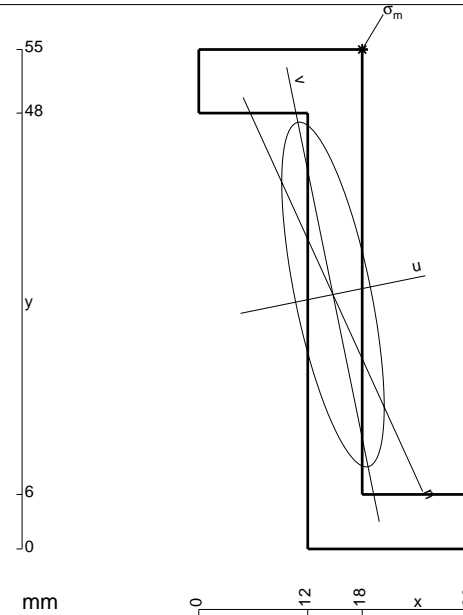

- A = 486. mm²
- J_x = 175218. mm⁴
- J_y = 15474. mm⁴
- J_{xy} = -33964. mm⁴
- J_u = 182139. mm⁴
- J_v = 8553. mm⁴
- α = arctg(2J_{xy}/(J_y-J_x))/2 = .2010
- c = cos α = .9799
- s = sin α = .1997
- x_g = 14.78 mm
- y_g = 28.02 mm
- N = -910. N
- T_y = -546. N
- M_x = 580580. Nmm
- x_m = 18. mm
- y_m = 55. mm
- u_m = 8.545 mm
- v_m = 25.79 mm
- σ_m = N/A - Mc_v/J_u - Ms_u/J_v = -198.3 N/mm²

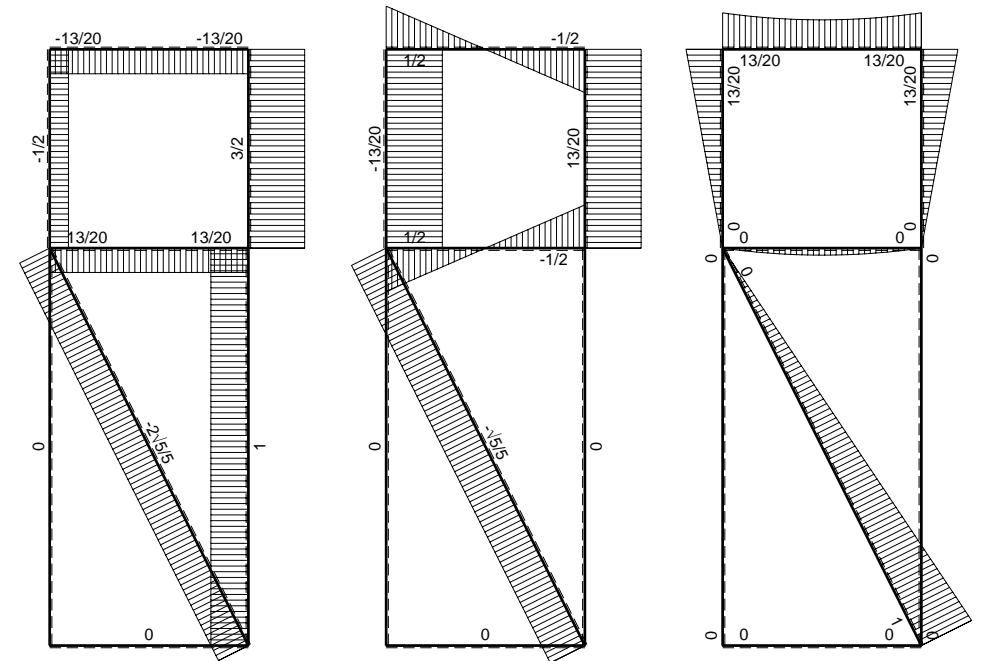
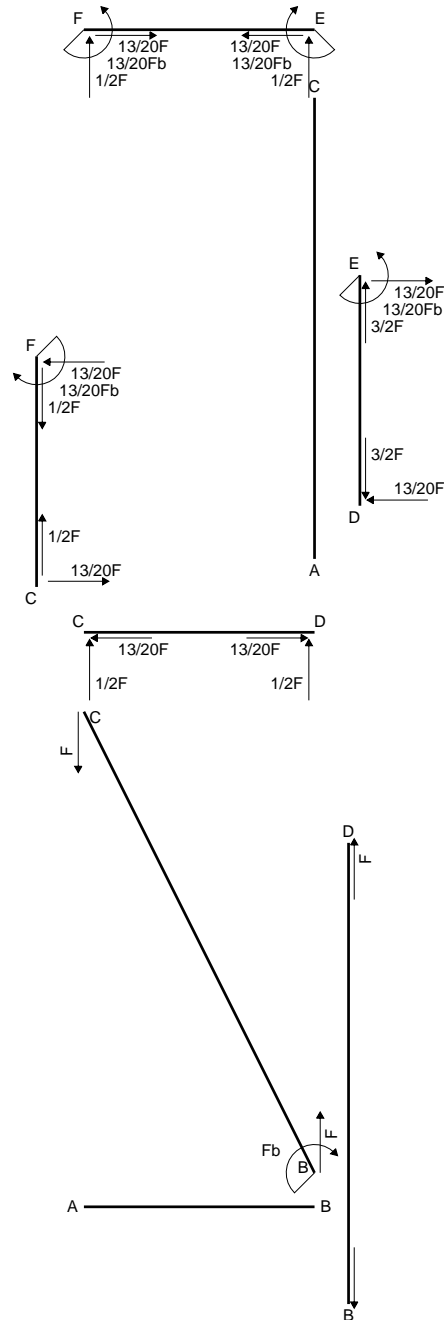

$\leftarrow \boxed{+} \rightarrow F$

$\boxed{+} \uparrow \downarrow F$

$\boxed{+} \curvearrowright F_b$

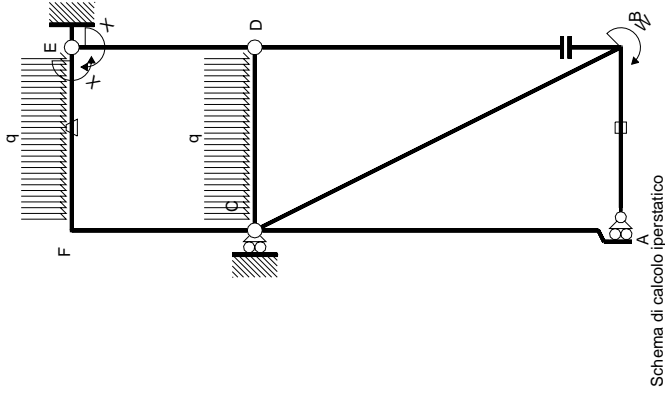

Schema di calcolo iperstatico

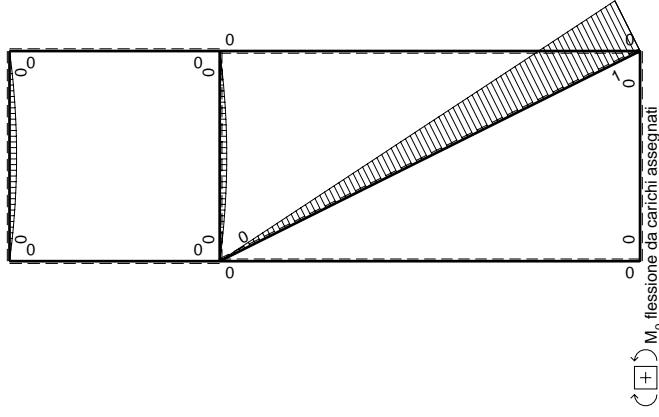

Quadro contributi PLV per iperstatica $X=W_{EF}$

\rightarrow	$M^x(x)$	$M^0(x)$	θ	$M^x M_0$	$M^x \theta$	$M^x M_x$	$\int M^x(M_0/EJ+\theta)dx$	$\int M^x M_x/EJdx$
AB b	0	0	0	0	0	0	0	0
BA b	0	0	0	0	0	0	0	0
BC $\sqrt{5}b$	0	$Fb-\sqrt{5}/5Fx$	0	0	0	0	0	0
CA 2b	0	0	0	0	0	0	0	0
AC 2b	0	0	0	0	0	0	0	0
DB 2b	0	0	0	0	0	0	0	0
BD 2b	0	0	0	0	0	0	0	0
DE b	-x/b	0	0	0	0	0	0	$1/3Xb/EJ$
ED b	1-x/b	0	0	0	0	0	0	$1/3Xb/EJ$
CD b	0	$1/2Fx-1/2qx^2$	0	0	0	0	0	0
DC b	0	$-1/2Fx+1/2qx^2$	0	0	0	0	0	0
EF b	-1	$-1/2Fx+1/2qx^2$	$-Fb/EJ$	$1/2Fx-1/2Fx^2/b$	Fb/EJ	1	$(1/12+1)Fb^2/EJ$	Xb/EJ
FE b	1	$1/2Fx-1/2qx^2$	Fb/EJ	$1/2Fx-1/2Fx^2/b$	Fb/EJ	1	$(1/12+1)Fb^2/EJ$	Xb/EJ
FC b	-1+x/b	0	0	0	0	0	0	$1/3Xb/EJ$
CF b	x/b	0	0	0	0	0	0	$1/3Xb/EJ$
totali								
iperstatica $X=W_{EF}$								

Sviluppi di calcolo iperstatica

$$L_{DE}^{xx} = \int_0^b (x^2/b^2) 1/EJ dx = [1/3 x^3/b^2]_0^b 1/EJ$$

$$= (1/3 b) 1/EJ = 1/3 b/EJ$$

$$L_{ED}^{xx} = \int_0^b (1 - 2x/b + x^2/b^2) 1/EJ dx = [x - x^2/b + 1/3 x^3/b^2]_0^b 1/EJ$$

$$= (b - b + 1/3 b) 1/EJ = 1/3 b/EJ$$

$$L_{EF}^{xx} = \int_0^b (1) 1/EJ dx = [x]_0^b 1/EJ$$

$$= (b) 1/EJ = b/EJ$$

$$L_{FE}^{xx} = \int_0^b (1) 1/EJ dx = [x]_0^b 1/EJ$$

$$= (b) 1/EJ = b/EJ$$

$$L_{FC}^{xx} = \int_0^b (1 - 2x/b + x^2/b^2) 1/EJ dx = [x - x^2/b + 1/3 x^3/b^2]_0^b 1/EJ$$

$$= (b - b + 1/3 b) 1/EJ = 1/3 b/EJ$$

$$L_{CF}^{xx} = \int_0^b (x^2/b^2) 1/EJ dx = [1/3 x^3/b^2]_0^b 1/EJ$$

$$= (1/3 b) 1/EJ = 1/3 b/EJ$$

$$L_{EF}^{xo} = \int_0^b (1/2 x/b - 1/2 x^2/b^2) Fb 1/EJ dx + \int_0^b (1) \theta dx = [1/4 x^2/b - 1/6 x^3/b^2]_0^b Fb 1/EJ + [x]_0^b \theta$$

$$= (1/4 b - 1/6 b) Fb 1/EJ + (b) \theta = 13/12 Fb^2/EJ$$

$$L_{FE}^{xo} = \int_0^b (1/2 x/b - 1/2 x^2/b^2) Fb 1/EJ dx + \int_0^b (-1) \theta dx = [1/4 x^2/b - 1/6 x^3/b^2]_0^b Fb 1/EJ + [-x]_0^b \theta$$

$$= (1/4 b - 1/6 b) Fb 1/EJ + (-b) \theta = 13/12 Fb^2/EJ$$

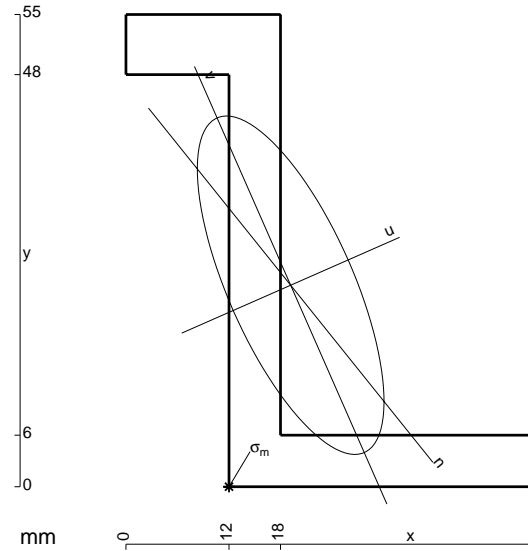

$$A = 594. \text{ mm}^2$$

$$J_x = 230851. \text{ mm}^4$$

$$J_y = 70234. \text{ mm}^4$$

$$J_{xy} = -87513. \text{ mm}^4$$

$$J_u = 269319. \text{ mm}^4$$

$$J_v = 31766. \text{ mm}^4$$

$$\alpha = \text{artg}(2J_{xy}/(J_y - J_x))/2 = .4141$$

$$c = \cos \alpha = .9155$$

$$s = \sin \alpha = .4024$$

$$x_g = 19.18 \text{ mm}$$

$$y_g = 23.47 \text{ mm}$$

$$N = -1145. \text{ N}$$

$$T_y = -572.4 \text{ N}$$

$$M_x = 793600. \text{ Nmm}$$

$$x_m = 12. \text{ mm}$$

$$u_m = -16.02 \text{ mm}$$

$$v_m = -18.6 \text{ mm}$$

$$\sigma_m = N/A - Mcv/J_u - Msu/J_v = 209.3 \text{ N/mm}^2$$

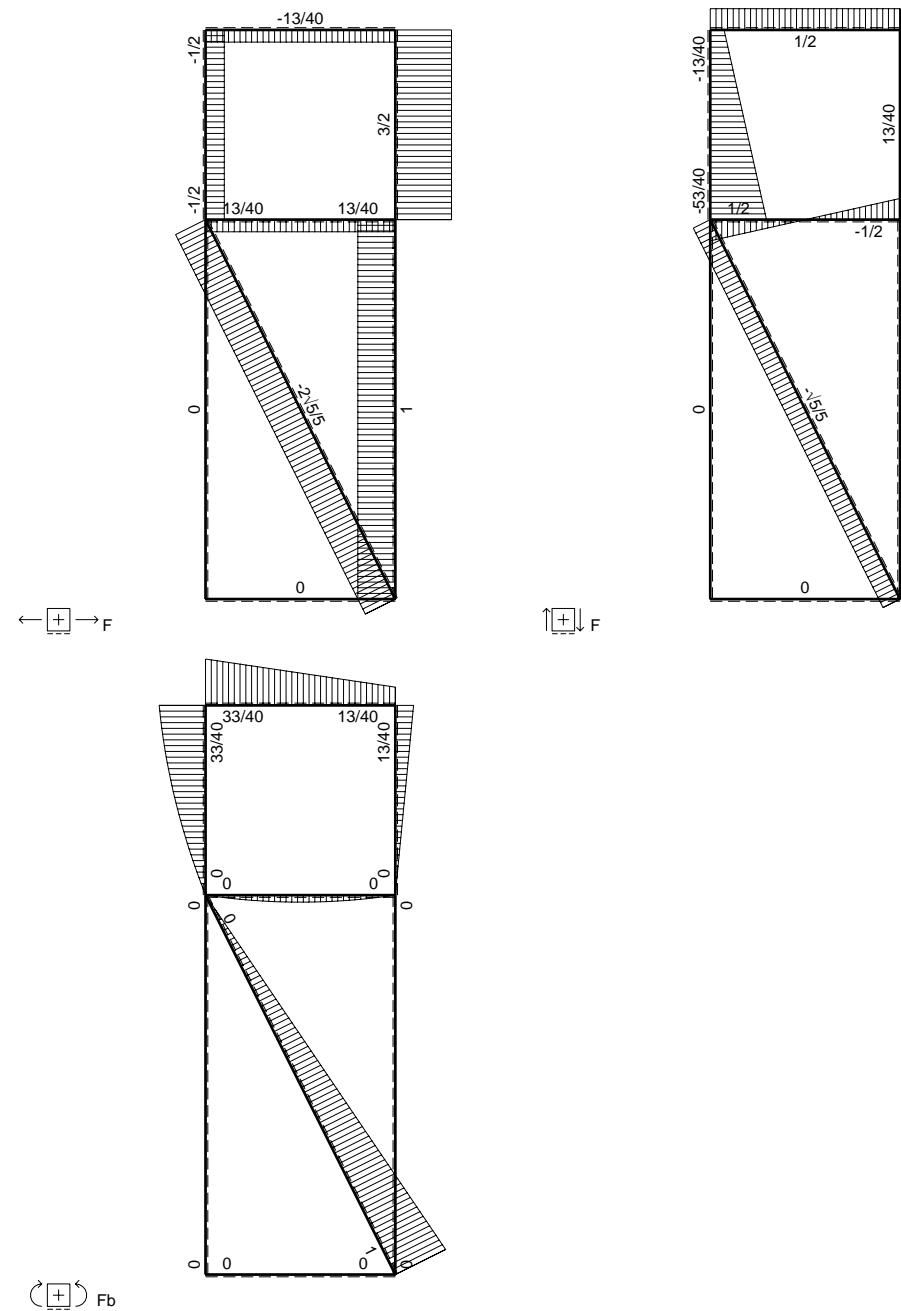
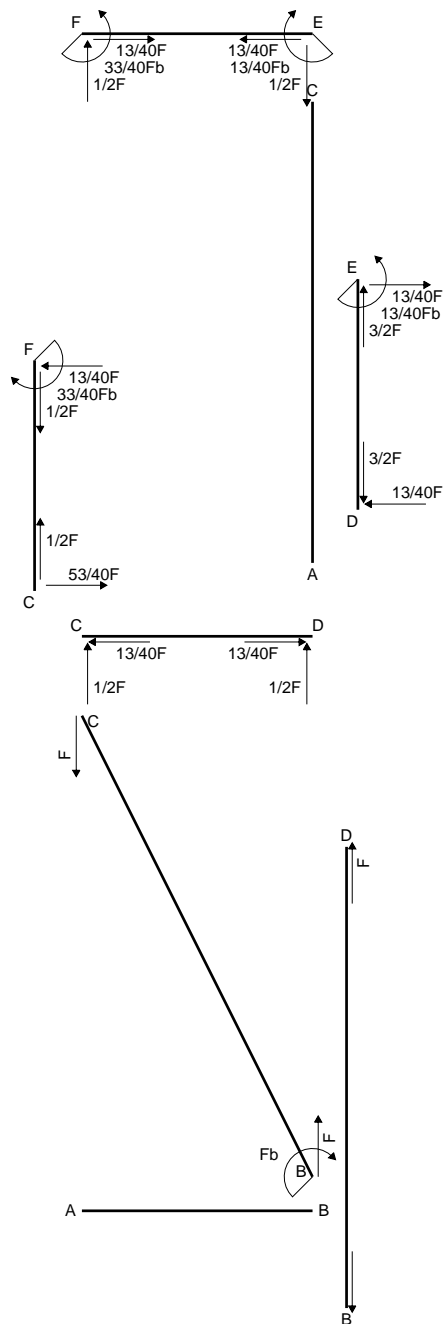

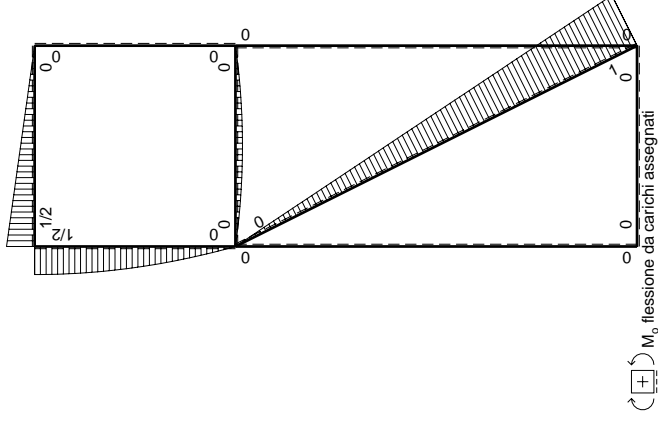
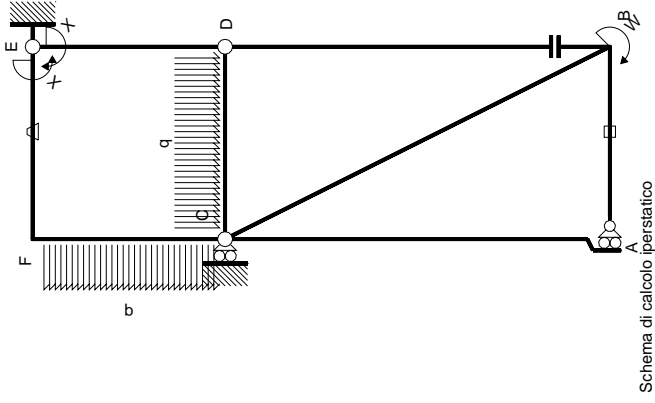

Quadro contributi PLV per iperstatica $X=W_{EP}$

\leftarrow	$M(x)$	$M_0(x)$	θ	$M_x M_0$	$M_x \theta$	$M_x M_x$	$\int M_x(M_0/EJ+\theta)dx$	$\int M_x M_x/EJdx$
AB b	0	0	0	0	0	0	0+0	0
BA b	0	0	0	0	0	0	0	0
BC $\sqrt{5}b$	$Fb-\sqrt{5}Fx$	0	0	0	0	0	0	0
CA 2b	0	0	0	0	0	0	0+0	0
DB 2b	0	0	0	0	0	0	0+0	0
BD 2b	0	0	0	0	0	0	0+0	0
DE b	-x/b	0	0	0	0	0	0+0	1/3Xb/EJ
ED b	1-x/b	0	0	0	0	0	0+0	1/3Xb/EJ
CD b	$1/2Fx-1/2qx^2$	0	0	0	0	0	0	0
DC b	$-1/2Fx+1/2qx^2$	0	0	0	0	0	0+0	0
EF b	-1	1/2Fx	-Fb/EJ	-1/2Fx	Fb/EJ	1	$(-1/4+1)Fb^2/EJ$	Xb/EJ
FE b	1	-1/2Fx	Fb/EJ	-1/2Fx	Fb/EJ	1	$(-1/4+1)Fb^2/EJ$	Xb/EJ
FC b	-1+x/b	$1/2Fb-1/2qx^2$	0	$-1/2Fb+1/2Fx+1/2qx^2/b-1/2qx^3/b$	0	0	$1-2x/b+x^2/b^2$	$1/3Xb/EJ$
CF b	x/b	$-Fx+1/2qx^2$	0	$-Fx^2/b+1/2qx^3/b$	0	0	x^2/b^2	$1/3Xb/EJ$
totali								
							$13/24Fb^2/EJ$	$5/3Xb/EJ$
								$-13/40Fb$

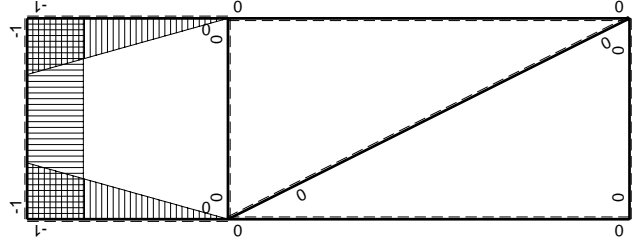

$$L_{DE}^{xx} = \int_0^b (x^2/b^2) 1/EJ dx = [1/3 x^3/b^2]_0^b 1/EJ$$

$$= (1/3 b) 1/EJ = 1/3 b/EJ$$

$$L_{ED}^{xx} = \int_0^b (1 - 2x/b + x^2/b^2) 1/EJ dx = [x - x^2/b + 1/3 x^3/b^2]_0^b 1/EJ$$

$$= (b - b + 1/3 b) 1/EJ = 1/3 b/EJ$$

$$L_{EF}^{xx} = \int_0^b (1) 1/EJ dx = [x]_0^b 1/EJ$$

$$= (b) 1/EJ = b/EJ$$

$$L_{FE}^{xx} = \int_0^b (1) 1/EJ dx = [x]_0^b 1/EJ$$

$$= (b) 1/EJ = b/EJ$$

$$L_{FC}^{xx} = \int_0^b (1 - 2x/b + x^2/b^2) 1/EJ dx = [x - x^2/b + 1/3 x^3/b^2]_0^b 1/EJ$$

$$= (b - b + 1/3 b) 1/EJ = 1/3 b/EJ$$

$$L_{CF}^{xx} = \int_0^b (x^2/b^2) 1/EJ dx = [1/3 x^3/b^2]_0^b 1/EJ$$

$$= (1/3 b) 1/EJ = 1/3 b/EJ$$

$$L_{EF}^{xo} = \int_0^b (-1/2 x/b) Fb 1/EJ dx + \int_0^b (1) \theta dx = [-1/4 x^2/b]_0^b Fb 1/EJ + [x]_0^b \theta$$

$$= (-1/4 b) Fb 1/EJ + (b) \theta = 3/4 Fb^2/EJ$$

$$L_{FE}^{xo} = \int_0^b (-1/2 + 1/2 x/b) Fb 1/EJ dx + \int_0^b (-1) \theta dx = [-1/2 x + 1/4 x^2/b]_0^b Fb 1/EJ + [-x]_0^b \theta$$

$$= (-1/2 b + 1/4 b) Fb 1/EJ + (-b) \theta = 3/4 Fb^2/EJ$$

$$L_{FC}^{xo} = \int_0^b (-1/2 + 1/2 x/b + 1/2 x^2/b^2 - 1/2 x^3/b^3) Fb 1/EJ dx$$

$$= [-1/2 x + 1/4 x^2/b + 1/6 x^3/b^2 - 1/8 x^4/b^3]_0^b Fb 1/EJ$$

$$= (-1/2 b + 1/4 b + 1/6 b - 1/8 b) Fb 1/EJ = -5/24 Fb^2/EJ$$

$$L_{CF}^{xo} = \int_0^b (-x^2/b^2 + 1/2 x^3/b^3) Fb 1/EJ dx = [-1/3 x^3/b^2 + 1/8 x^4/b^3]_0^b Fb 1/EJ$$

$$= (-1/3 b + 1/8 b) Fb 1/EJ = -5/24 Fb^2/EJ$$

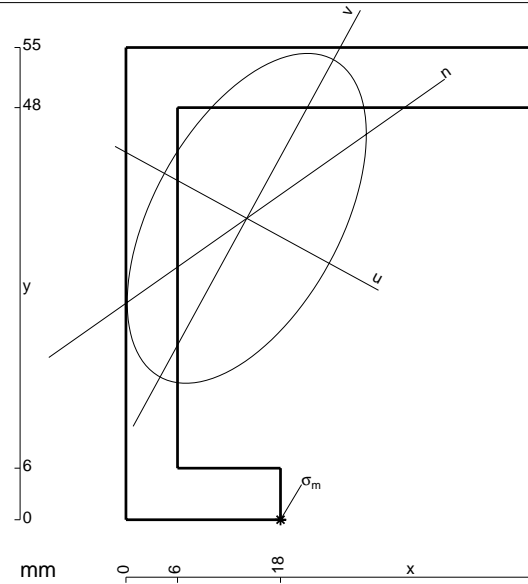

- A = 696. mm²
- J_x = 256929. mm⁴
- J_y = 134973. mm⁴
- J_{xy} = 94891. mm⁴
- J_u = 308745. mm⁴
- J_v = 83156. mm⁴
- α = arctg(2J_{xy}/(J_y-J_x))/2 = -.4998
- c = cos α = .8777
- s = sin α = -.4793
- x_g = 14.07 mm
- y_g = 35.1 mm
- N = -1512. N
- T_y = -755.8 N
- M_x = 1115400. Nmm
- x_m = 18. mm
- u_m = 20.27 mm
- v_m = -28.93 mm
- σ_m = N/A - Mcv/J_u - Msu/J_v = 219.9 N/mm²

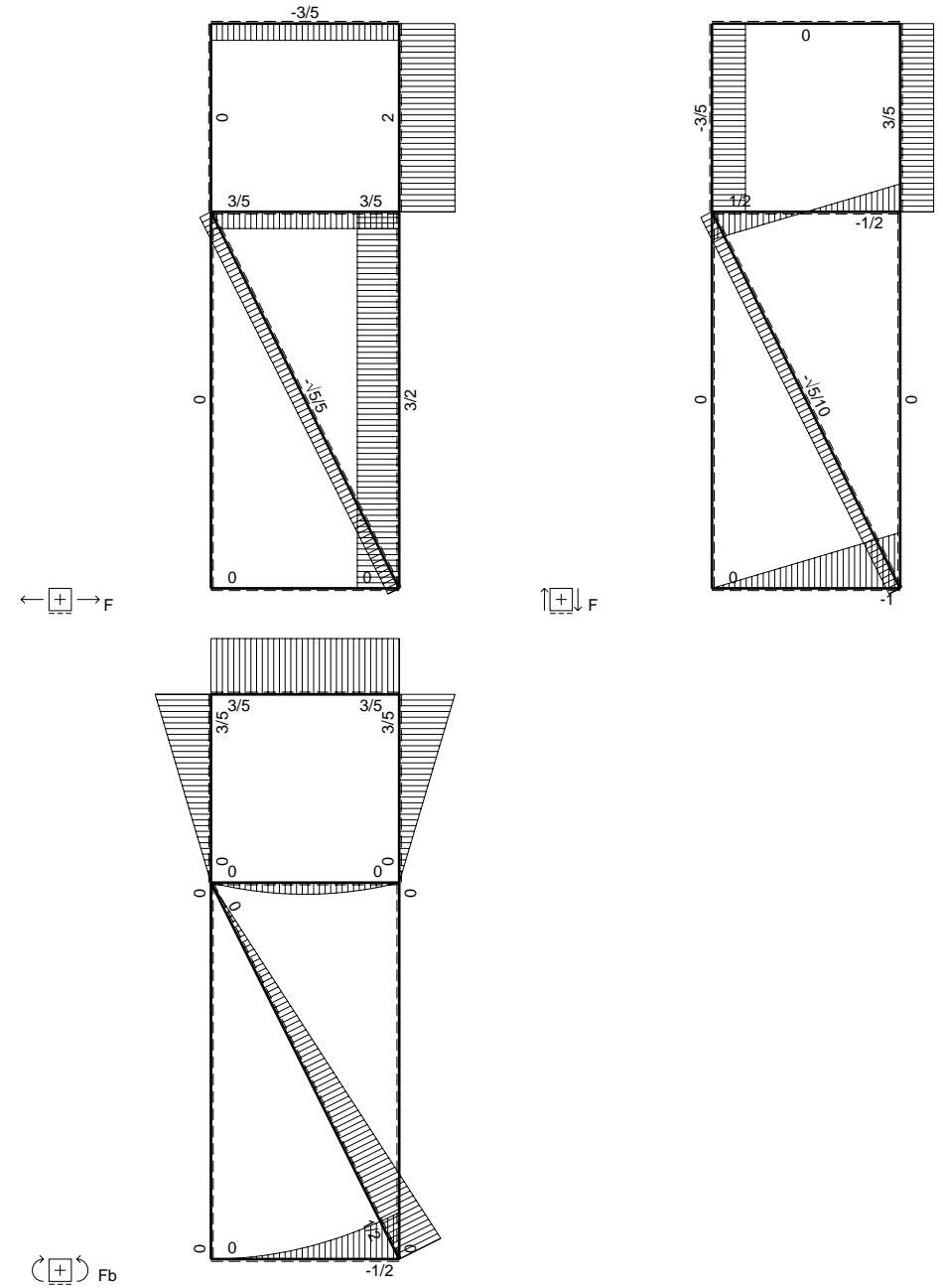
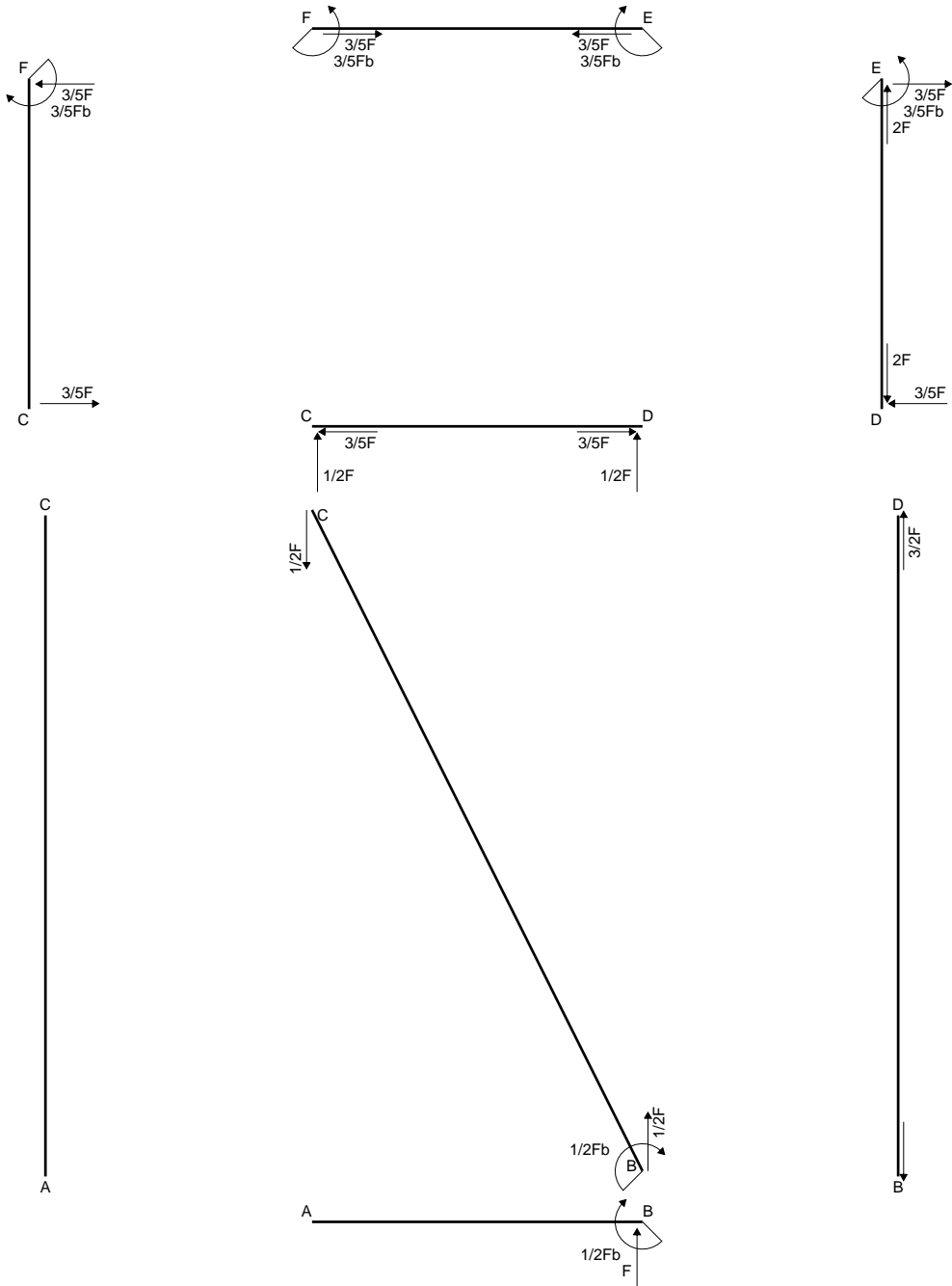

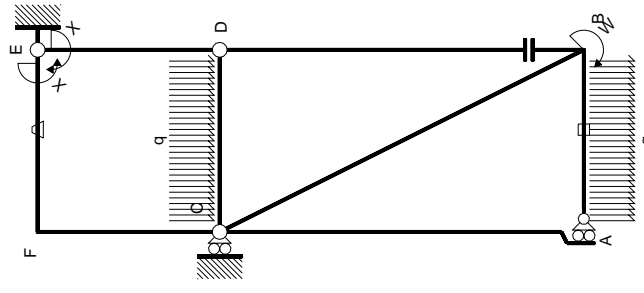

Schema di calcolo iperstatico

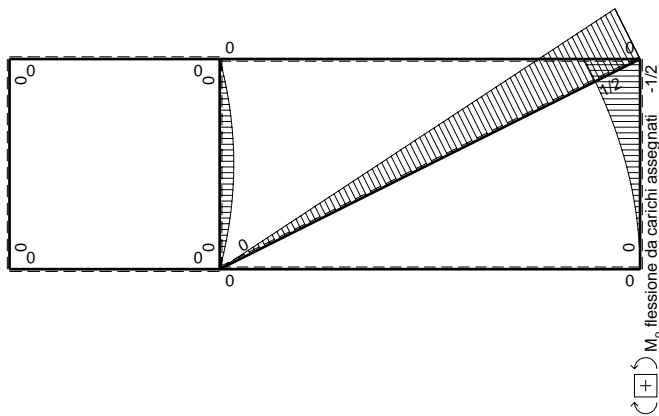

M_0 flessione da carichi assegnati -1/2

Quadro contributi PLV per iperstatica $X=W_{EF}$

\rightarrow	$M_x(x)$	$M_0(x)$	θ	$M_x M_0$	$M_x \theta$	$M_x M_x$	$\int M_x(M_0/EJ+\theta)dx$	$\int X M_x M_x / EJ dx$	
AB b	0	$-1/2qx^2$	0	0	0	0	0+0	0	
BA b	0	$1/2Fb-Fx+1/2qx^2$	0	0	0	0	0+0	0	
BC $\sqrt{5}b$	0	$1/2Fb-\sqrt{5}/10Fx$	0	0	0	0	0	0	
AC 2b	0	0	0	0	0	0	0+0	0	
CA 2b	0	0	0	0	0	0	0+0	0	
DB 2b	0	0	0	0	0	0	0+0	0	
BD 2b	0	0	0	0	0	0	0+0	0	
DE b	$-x/b$	0	0	0	0	x^2/b^2	0+0	$1/3Xb/EJ$	
ED b	$1-x/b$	0	0	0	0	$1-2x/b+x^2/b^2$	0+0	$1/3Xb/EJ$	
CD b	0	$1/2Fx-1/2qx^2$	0	0	0	0	0+0	0	
DC b	0	$-1/2Fx+1/2qx^2$	0	0	0	0	0+0	0	
EF b	-1	0	$-Fb/EJ$	0	Fb/EJ	1	$(0+1)Fb^2/EJ$	Xb/EJ	
FE b	1	0	Fb/EJ	0	Fb/EJ	1			
FC b	$-1+x/b$	0	0	0	0	$1-2x/b+x^2/b^2$	0+0	$1/3Xb/EJ$	
CF b	x/b	0	0	0	0	x^2/b^2	Fb^2/EJ	$5/3Xb/EJ$	
	totali								
	iperstatica $X=W_{EF}$								

Sviluppi di calcolo iperstatica

M_x flessione da iperstatica $X=1$

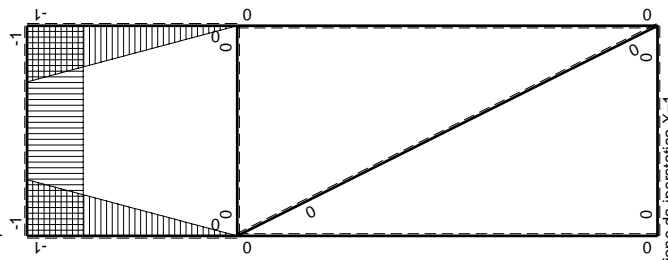

$$L_{DE}^{xx} = \int_0^b (x^2/b^2) 1/EJ dx = [1/3 x^3/b^2]_0^b 1/EJ$$

$$= (1/3 b) 1/EJ = 1/3 b/EJ$$

$$L_{ED}^{xx} = \int_0^b (1 - 2x/b + x^2/b^2) 1/EJ dx = [x - x^2/b + 1/3 x^3/b^2]_0^b 1/EJ$$

$$= (b - b + 1/3 b) 1/EJ = 1/3 b/EJ$$

$$L_{EF}^{xx} = \int_0^b (1) 1/EJ dx = [x]_0^b 1/EJ$$

$$= (b) 1/EJ = b/EJ$$

$$L_{FE}^{xx} = \int_0^b (1) 1/EJ dx = [x]_0^b 1/EJ$$

$$= (b) 1/EJ = b/EJ$$

$$L_{FC}^{xx} = \int_0^b (1 - 2x/b + x^2/b^2) 1/EJ dx = [x - x^2/b + 1/3 x^3/b^2]_0^b 1/EJ$$

$$= (b - b + 1/3 b) 1/EJ = 1/3 b/EJ$$

$$L_{CF}^{xx} = \int_0^b (x^2/b^2) 1/EJ dx = [1/3 x^3/b^2]_0^b 1/EJ$$

$$= (1/3 b) 1/EJ = 1/3 b/EJ$$

$$L_{EF}^{xo} = \int_0^b (1) \theta dx = [x]_0^b \theta$$

$$= (b) \theta = Fb^2/EJ$$

$$L_{FE}^{xo} = \int_0^b (-1) \theta dx = [-x]_0^b \theta$$

$$= (-b) \theta = -Fb^2/EJ$$

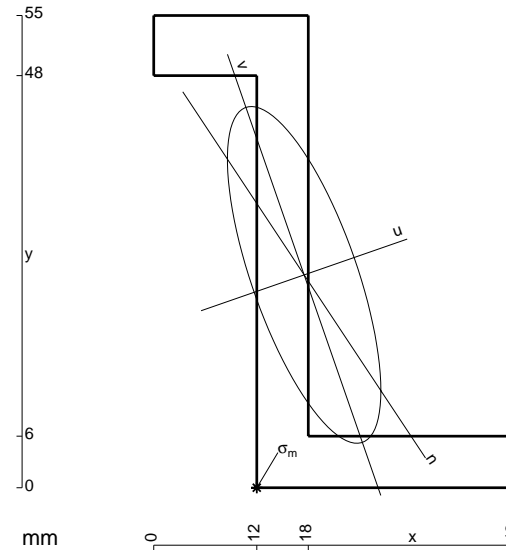

$$A = 558. \text{ mm}^2$$

$$J_x = 214685. \text{ mm}^4$$

$$J_y = 44581. \text{ mm}^4$$

$$J_{xy} = -67260. \text{ mm}^4$$

$$J_u = 238066. \text{ mm}^4$$

$$J_v = 21201. \text{ mm}^4$$

$$\alpha = \text{artg}(2J_{xy}/(J_y - J_x))/2 = .3346$$

$$c = \cos \alpha = .9446$$

$$s = \sin \alpha = .3283$$

$$x_g = 17.52 \text{ mm}$$

$$y_g = 24.79 \text{ mm}$$

$$N = 3620. \text{ N}$$

$$T_y = 1086. \text{ N}$$

$$M_x = 760200. \text{ Nmm}$$

$$x_m = 12. \text{ mm}$$

$$u_m = -13.35 \text{ mm}$$

$$v_m = -21.6 \text{ mm}$$

$$\sigma_m = N/A - Mcv/J_u - Msu/J_v = 228.8 \text{ N/mm}^2$$

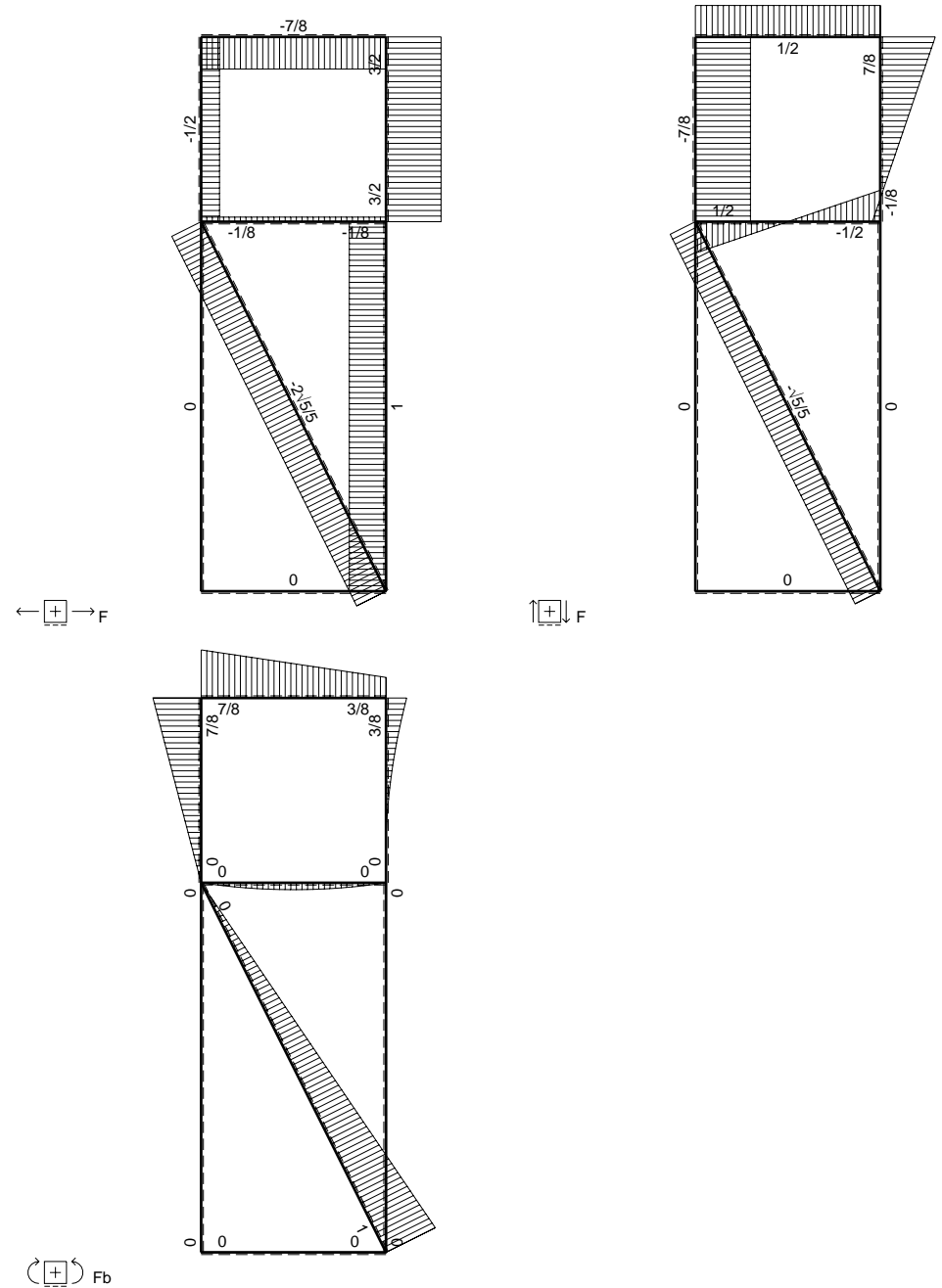
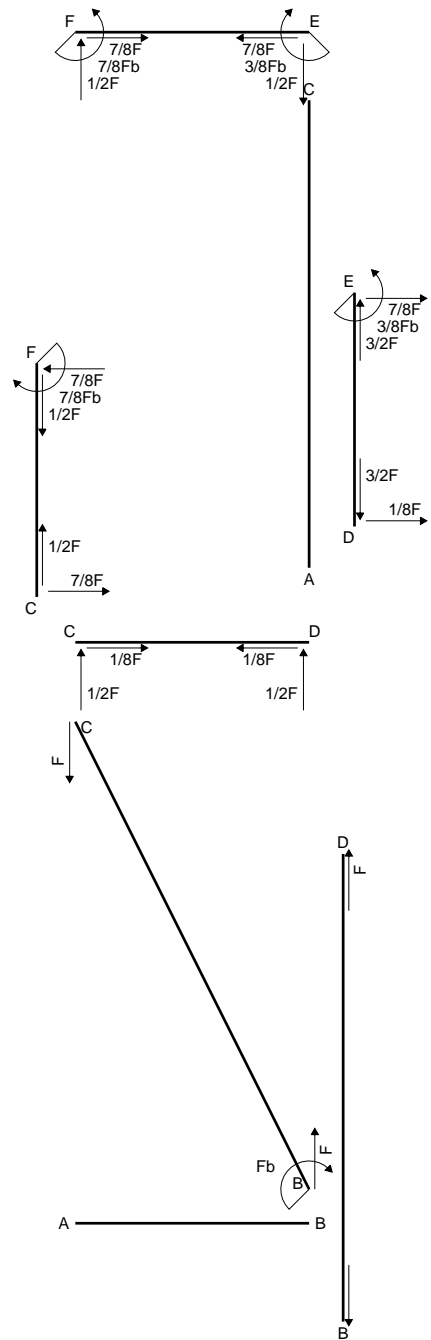

$$L_{DE}^{xx} = \int_0^b (x^2/b^2) 1/EJ dx = [1/3 x^3/b^2]_0^b 1/EJ$$

$$= (1/3 b) 1/EJ = 1/3 b/EJ$$

$$L_{ED}^{xx} = \int_0^b (1 - 2x/b + x^2/b^2) 1/EJ dx = [x - x^2/b + 1/3 x^3/b^2]_0^b 1/EJ$$

$$= (b - b + 1/3 b) 1/EJ = 1/3 b/EJ$$

$$L_{EF}^{xx} = \int_0^b (1) 1/EJ dx = [x]_0^b 1/EJ$$

$$= (b) 1/EJ = b/EJ$$

$$L_{FE}^{xx} = \int_0^b (1) 1/EJ dx = [x]_0^b 1/EJ$$

$$= (b) 1/EJ = b/EJ$$

$$L_{FC}^{xx} = \int_0^b (1 - 2x/b + x^2/b^2) 1/EJ dx = [x - x^2/b + 1/3 x^3/b^2]_0^b 1/EJ$$

$$= (b - b + 1/3 b) 1/EJ = 1/3 b/EJ$$

$$L_{CF}^{xx} = \int_0^b (x^2/b^2) 1/EJ dx = [1/3 x^3/b^2]_0^b 1/EJ$$

$$= (1/3 b) 1/EJ = 1/3 b/EJ$$

$$L_{DE}^{xo} = \int_0^b (1/2 x^2/b^2 - 1/2 x^3/b^3) Fb 1/EJ dx = [1/6 x^3/b^2 - 1/8 x^4/b^3]_0^b Fb 1/EJ$$

$$= (1/6 b - 1/8 b) Fb 1/EJ = 1/24 Fb^2/EJ$$

$$L_{ED}^{xo} = \int_0^b (1/2 x/b - x^2/b^2 + 1/2 x^3/b^3) Fb 1/EJ dx = [1/4 x^2/b - 1/3 x^3/b^2 + 1/8 x^4/b^3]_0^b Fb 1/EJ$$

$$= (1/4 b - 1/3 b + 1/8 b) Fb 1/EJ = 1/24 Fb^2/EJ$$

$$L_{EF}^{xo} = \int_0^b (-1/2 x/b) Fb 1/EJ dx + \int_0^b (1) \theta dx = [-1/4 x^2/b]_0^b Fb 1/EJ + [x]_0^b \theta$$

$$= (-1/4 b) Fb 1/EJ + (b) \theta = 3/4 Fb^2/EJ$$

$$L_{FE}^{xo} = \int_0^b (-1/2 + 1/2 x/b) Fb 1/EJ dx + \int_0^b (-1) \theta dx = [-1/2 x + 1/4 x^2/b]_0^b Fb 1/EJ + [-x]_0^b \theta$$

$$= (-1/2 b + 1/4 b) Fb 1/EJ + (-b) \theta = 3/4 Fb^2/EJ$$

$$L_{FC}^{xo} = \int_0^b (-1/2 + x/b - 1/2 x^2/b^2) Fb 1/EJ dx = [-1/2 x + 1/2 x^2/b - 1/6 x^3/b^2]_0^b Fb 1/EJ$$

$$= (-1/2 b + 1/2 b - 1/6 b) Fb 1/EJ = -1/6 Fb^2/EJ$$

$$L_{CF}^{xo} = \int_0^b (-1/2 x^2/b^2) Fb 1/EJ dx = [-1/6 x^3/b^2]_0^b Fb 1/EJ$$

$$= (-1/6 b) Fb 1/EJ = -1/6 Fb^2/EJ$$

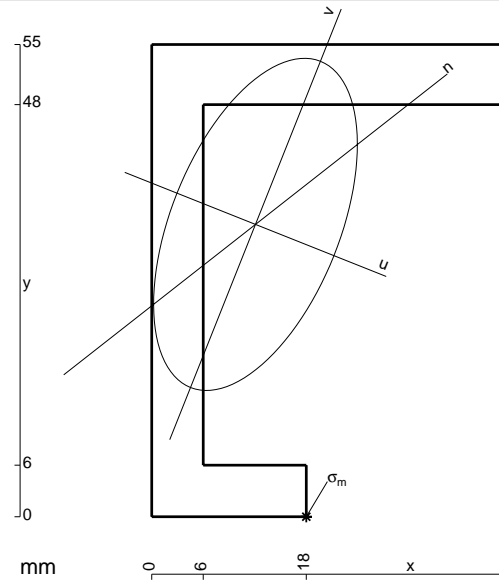

- A = 654. mm²
- J_x = 244740. mm⁴
- J_y = 92084. mm⁴
- J_{xy} = 72222. mm⁴
- J_u = 273493. mm⁴
- J_v = 63331. mm⁴
- α = arctg(2J_{xy}/(J_y-J_x))/2 = -.3789
- c = cos α = .9291
- s = sin α = -.3699
- x_g = 12.08 mm
- y_g = 34.05 mm
- N = -1422. N
- T_y = -711.1 N
- M_x = 1176600. Nmm
- x_m = 18. mm
- u_m = 18.09 mm
- v_m = -29.45 mm
- σ_m = N/A - Mcv/J_u - Msu/J_v = 239.9 N/mm²

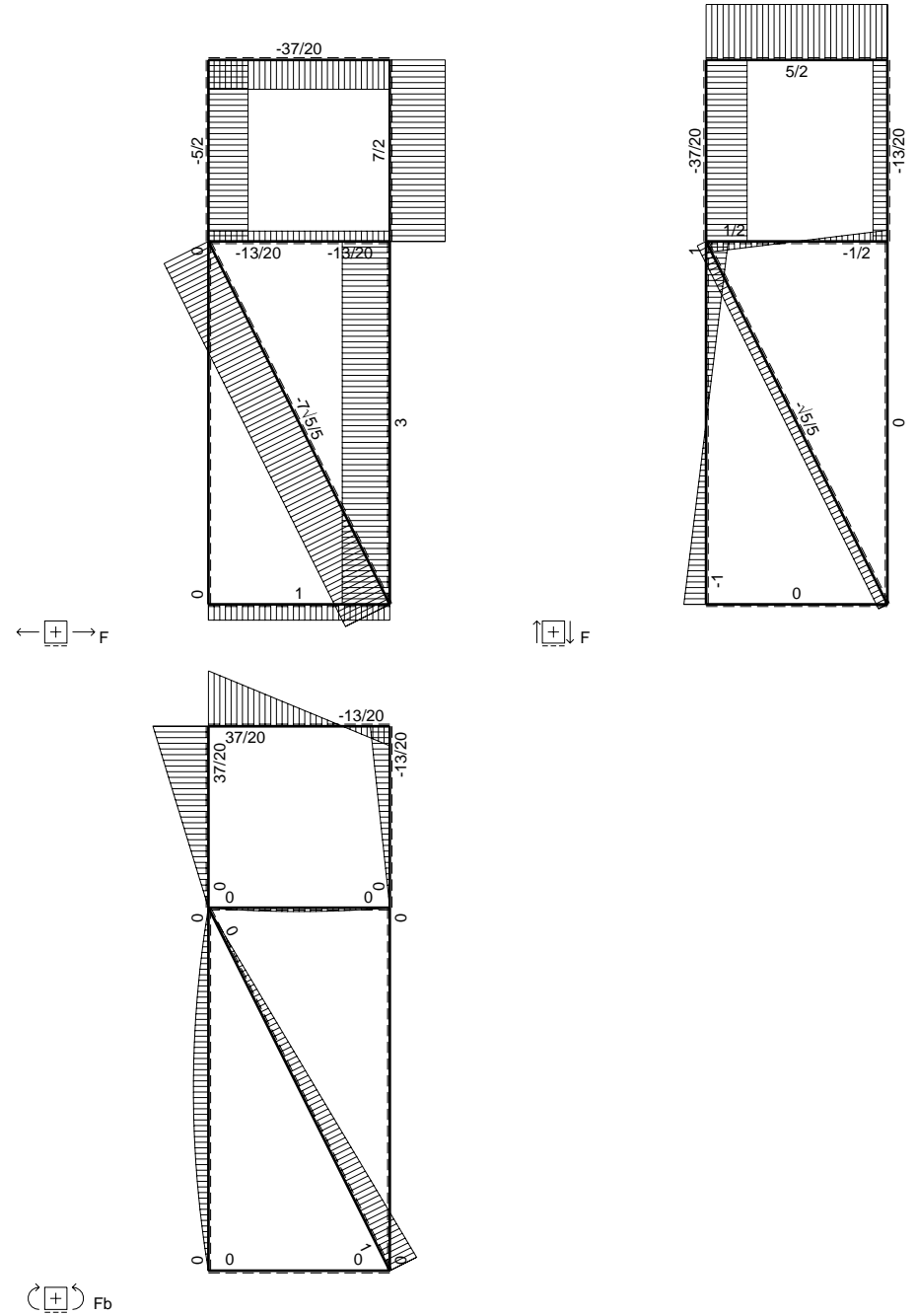
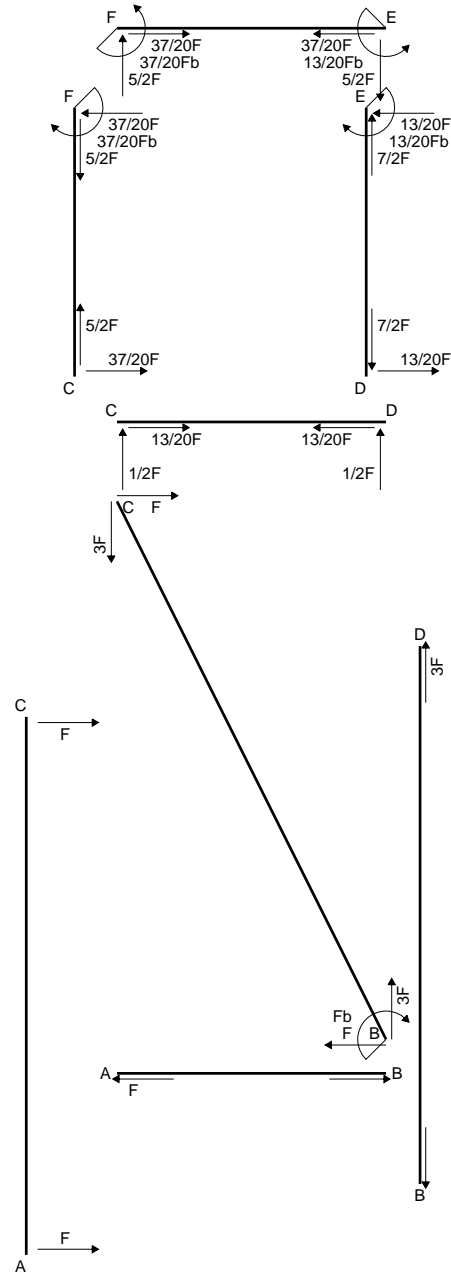

$$L_{DE}^{xx} = \int_0^b (x^2/b^2) 1/EJ dx = [1/3 x^3/b^2]_0^b 1/EJ$$

$$= (1/3 b) 1/EJ = 1/3 b/EJ$$

$$L_{ED}^{xx} = \int_0^b (1 - 2x/b + x^2/b^2) 1/EJ dx = [x - x^2/b + 1/3 x^3/b^2]_0^b 1/EJ$$

$$= (b - b + 1/3 b) 1/EJ = 1/3 b/EJ$$

$$L_{EF}^{xx} = \int_0^b (1) 1/EJ dx = [x]_0^b 1/EJ$$

$$= (b) 1/EJ = b/EJ$$

$$L_{FE}^{xx} = \int_0^b (1) 1/EJ dx = [x]_0^b 1/EJ$$

$$= (b) 1/EJ = b/EJ$$

$$L_{FC}^{xx} = \int_0^b (1 - 2x/b + x^2/b^2) 1/EJ dx = [x - x^2/b + 1/3 x^3/b^2]_0^b 1/EJ$$

$$= (b - b + 1/3 b) 1/EJ = 1/3 b/EJ$$

$$L_{CF}^{xx} = \int_0^b (x^2/b^2) 1/EJ dx = [1/3 x^3/b^2]_0^b 1/EJ$$

$$= (1/3 b) 1/EJ = 1/3 b/EJ$$

$$L_{EF}^{xo} = \int_0^b (-5/2 x/b) Fb 1/EJ dx + \int_0^b (1) \theta dx = [-5/4 x^2/b]_0^b Fb 1/EJ + [x]_0^b \theta$$

$$= (-5/4 b) Fb 1/EJ + (b) \theta = -1/4 Fb^2/EJ$$

$$L_{FE}^{xo} = \int_0^b (-5/2 + 5/2 x/b) Fb 1/EJ dx + \int_0^b (-1) \theta dx = [-5/2 x + 5/4 x^2/b]_0^b Fb 1/EJ + [-x]_0^b \theta$$

$$= (-5/2 b + 5/4 b) Fb 1/EJ + (-b) \theta = -1/4 Fb^2/EJ$$

$$L_{FC}^{xo} = \int_0^b (-5/2 + 5x/b - 5/2 x^2/b^2) Fb 1/EJ dx = [-5/2 x + 5/2 x^2/b - 5/6 x^3/b^2]_0^b Fb 1/EJ$$

$$= (-5/2 b + 5/2 b - 5/6 b) Fb 1/EJ = -5/6 Fb^2/EJ$$

$$L_{CF}^{xo} = \int_0^b (-5/2 x^2/b^2) Fb 1/EJ dx = [-5/6 x^3/b^2]_0^b Fb 1/EJ$$

$$= (-5/6 b) Fb 1/EJ = -5/6 Fb^2/EJ$$

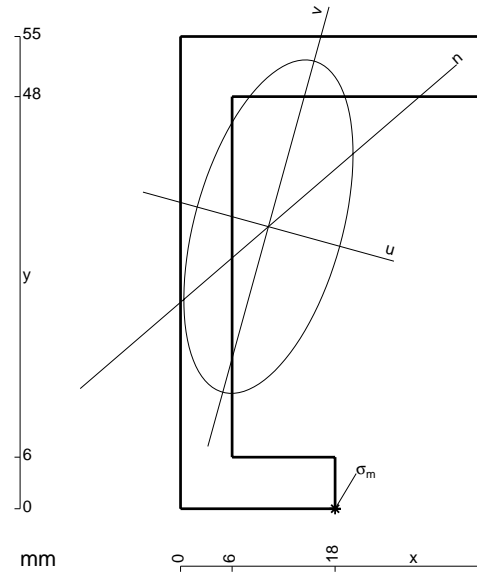

$A = 612. \text{ mm}^2$
 $J_x = 230903. \text{ mm}^4$
 $J_y = 59438. \text{ mm}^4$
 $J_{xy} = 51141. \text{ mm}^4$
 $J_u = 244998. \text{ mm}^4$
 $J_v = 45343. \text{ mm}^4$
 $\alpha = \text{artg}(2J_{xy}/(J_y - J_x))/2 = -.2689$
 $c = \cos \alpha = .9641$
 $s = \sin \alpha = -.2657$
 $x_g = 10.24 \text{ mm}$
 $y_g = 32.85 \text{ mm}$
 $N = -2461. \text{ N}$
 $T_y = 3325. \text{ N}$
 $M_x = 959595. \text{ Nmm}$
 $x_m = 18. \text{ mm}$
 $u_m = 16.21 \text{ mm}$
 $v_m = -29.61 \text{ mm}$
 $\sigma_m = N/A - Mcv/J_u - Msu/J_v = 199. \text{ N/mm}^2$

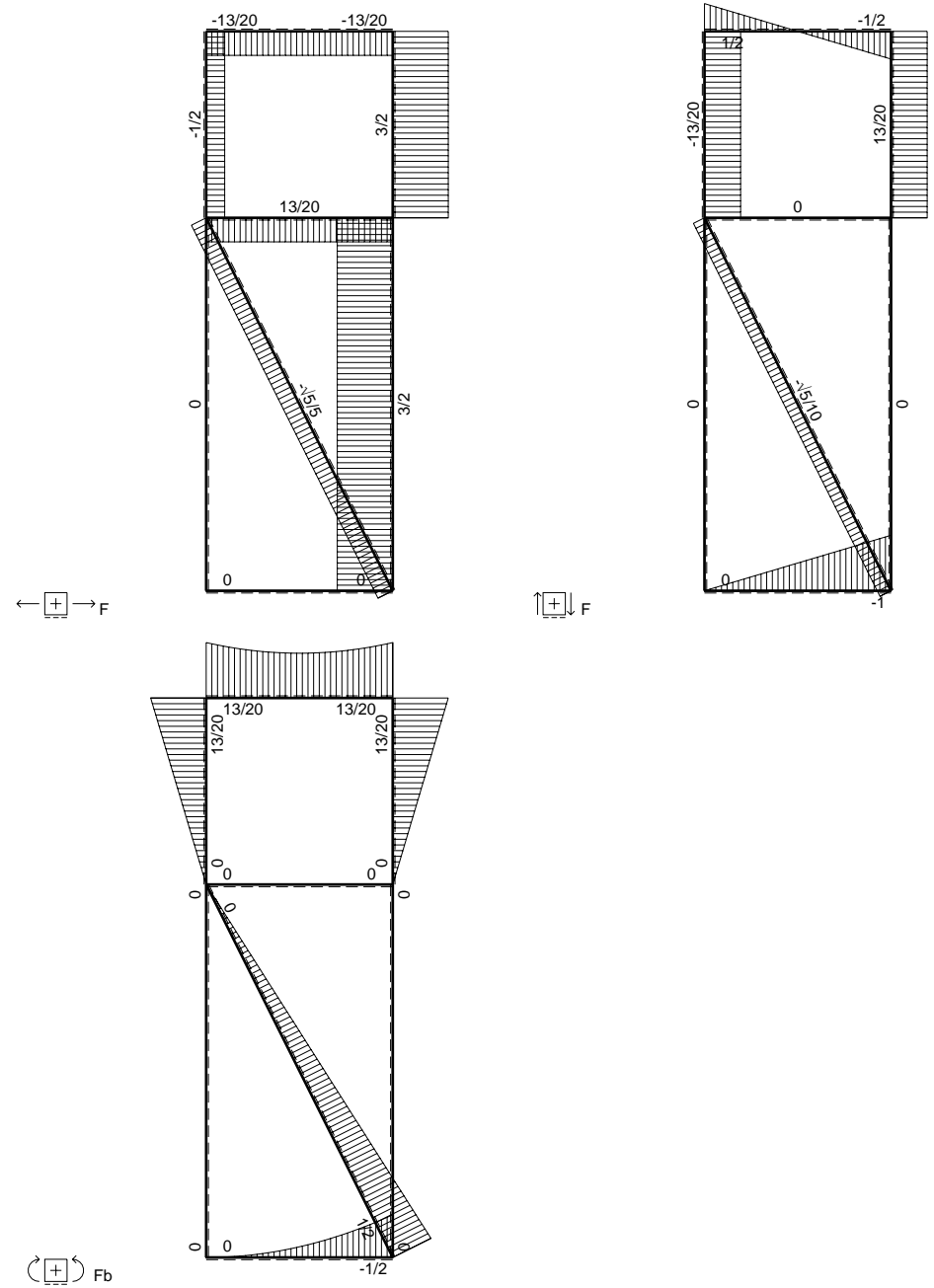
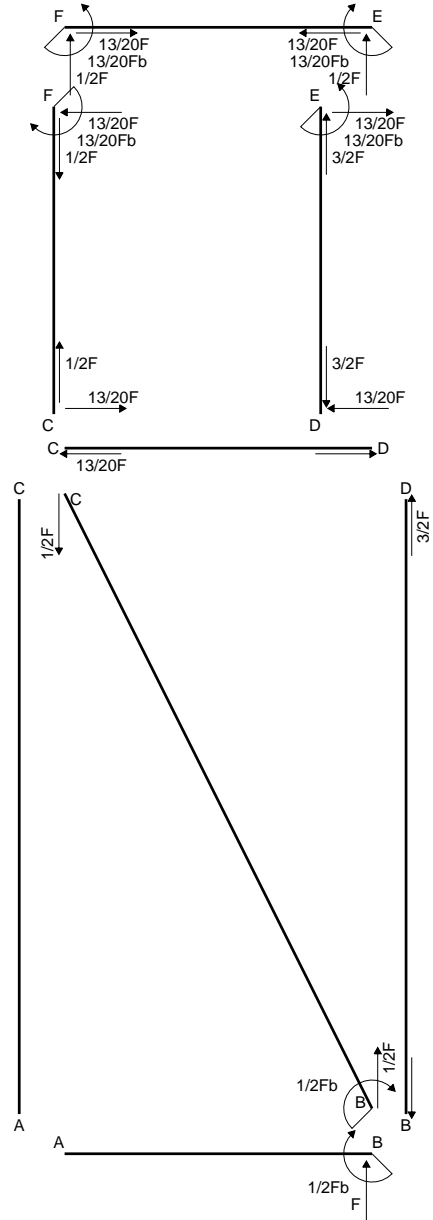

$$L_{DE}^{xx} = \int_0^b (x^2/b^2) 1/EJ dx = [1/3 x^3/b^2]_0^b 1/EJ$$

$$= (1/3 b) 1/EJ = 1/3 b/EJ$$

$$L_{ED}^{xx} = \int_0^b (1 - 2x/b + x^2/b^2) 1/EJ dx = [x - x^2/b + 1/3 x^3/b^2]_0^b 1/EJ$$

$$= (b - b + 1/3 b) 1/EJ = 1/3 b/EJ$$

$$L_{EF}^{xx} = \int_0^b (1) 1/EJ dx = [x]_0^b 1/EJ$$

$$= (b) 1/EJ = b/EJ$$

$$L_{FE}^{xx} = \int_0^b (1) 1/EJ dx = [x]_0^b 1/EJ$$

$$= (b) 1/EJ = b/EJ$$

$$L_{FC}^{xx} = \int_0^b (1 - 2x/b + x^2/b^2) 1/EJ dx = [x - x^2/b + 1/3 x^3/b^2]_0^b 1/EJ$$

$$= (b - b + 1/3 b) 1/EJ = 1/3 b/EJ$$

$$L_{CF}^{xx} = \int_0^b (x^2/b^2) 1/EJ dx = [1/3 x^3/b^2]_0^b 1/EJ$$

$$= (1/3 b) 1/EJ = 1/3 b/EJ$$

$$L_{EF}^{xo} = \int_0^b (1/2 x/b - 1/2 x^2/b^2) Fb 1/EJ dx + \int_0^b (1) \theta dx = [1/4 x^2/b - 1/6 x^3/b^2]_0^b Fb 1/EJ + [x]_0^b \theta$$

$$= (1/4 b - 1/6 b) Fb 1/EJ + (b) \theta = 13/12 Fb^2/EJ$$

$$L_{FE}^{xo} = \int_0^b (1/2 x/b - 1/2 x^2/b^2) Fb 1/EJ dx + \int_0^b (-1) \theta dx = [1/4 x^2/b - 1/6 x^3/b^2]_0^b Fb 1/EJ + [-x]_0^b \theta$$

$$= (1/4 b - 1/6 b) Fb 1/EJ + (-b) \theta = 13/12 Fb^2/EJ$$

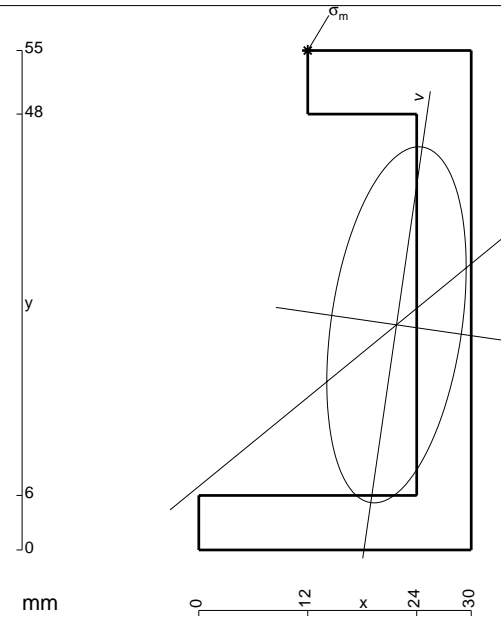

- A = 558. mm²
- J_x = 214685. mm⁴
- J_y = 32876. mm⁴
- J_{xy} = 26875. mm⁴
- J_u = 218575. mm⁴
- J_v = 28986. mm⁴
- α = artg(2J_{xy}/(J_y-J_x))/2 = -.1437
- c = cosα = .9897
- s = sinα = -.1432
- x_g = 21.77 mm
- y_g = 24.79 mm
- N = -2464. N
- T_y = -1895. N
- M_x = 1034670. Nmm
- x_m = 12. mm
- y_m = 55. mm
- u_m = -14. mm
- v_m = 28.5 mm
- σ_m = N/A - Mcv/J_v - Msu/J_u = -209.5 N/mm²

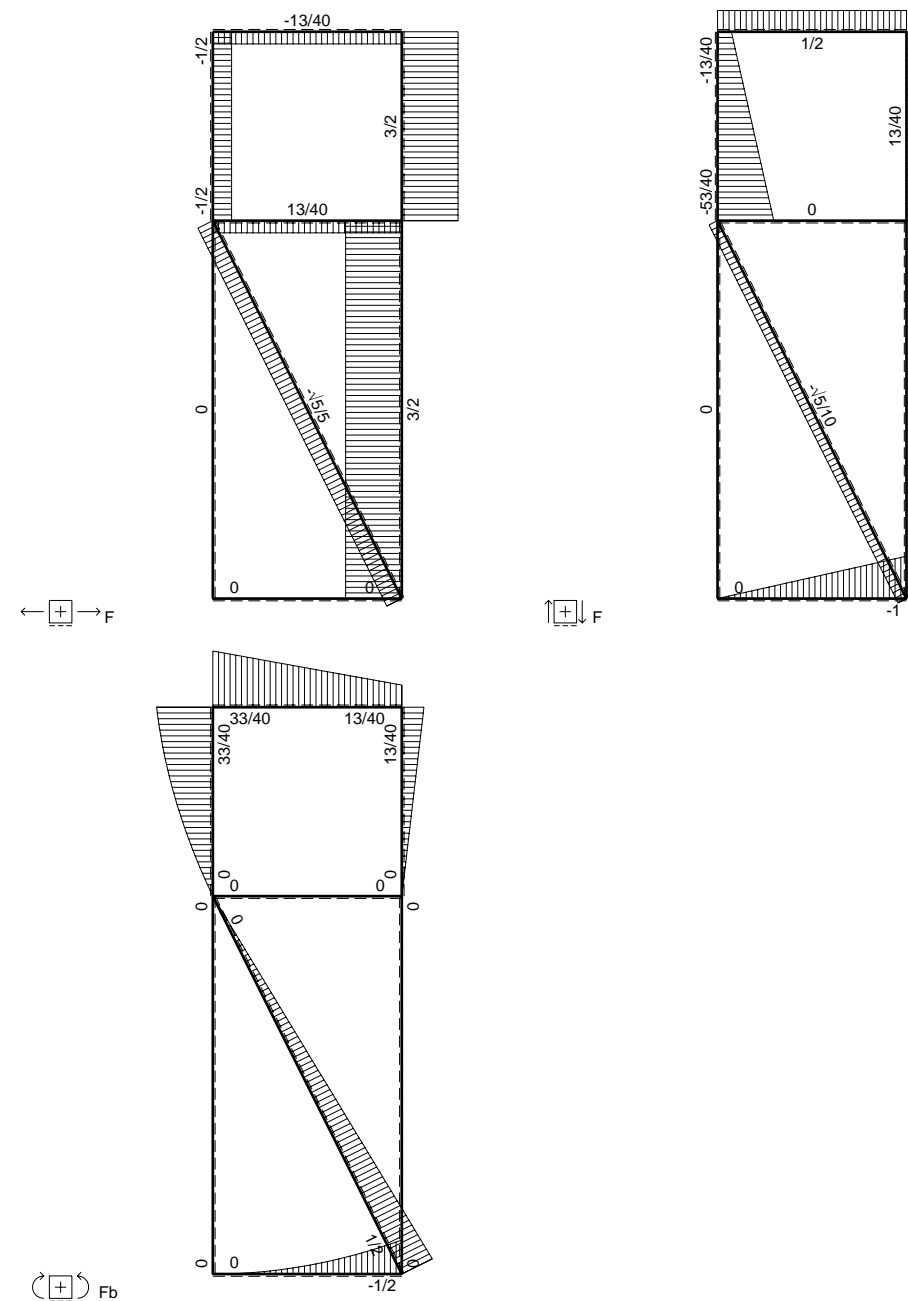
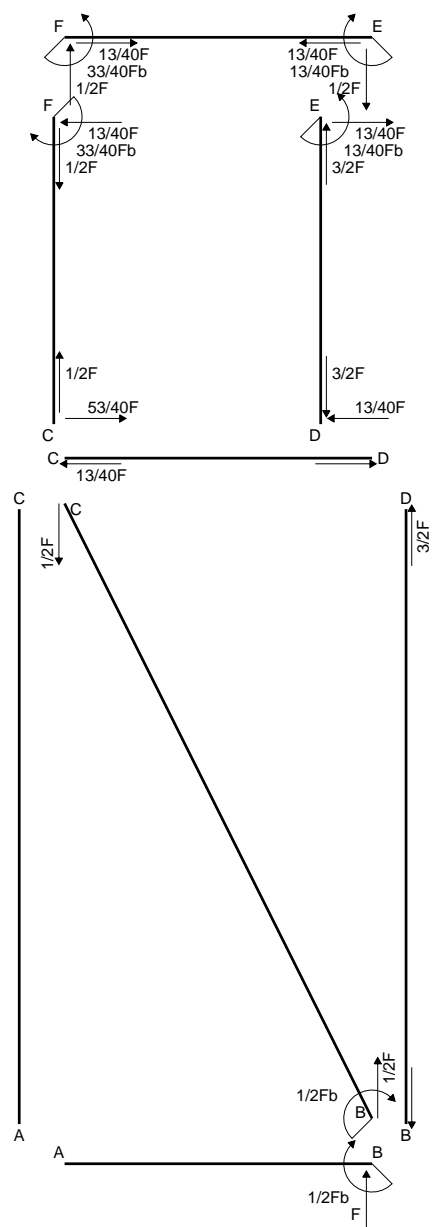

$$L_{DE}^{xx} = \int_0^b (x^2/b^2) 1/EJ dx = [1/3 x^3/b^2]_0^b 1/EJ$$

$$= (1/3 b) 1/EJ = 1/3 b/EJ$$

$$L_{ED}^{xx} = \int_0^b (1 - 2x/b + x^2/b^2) 1/EJ dx = [x - x^2/b + 1/3 x^3/b^2]_0^b 1/EJ$$

$$= (b - b + 1/3 b) 1/EJ = 1/3 b/EJ$$

$$L_{EF}^{xx} = \int_0^b (1) 1/EJ dx = [x]_0^b 1/EJ$$

$$= (b) 1/EJ = b/EJ$$

$$L_{FE}^{xx} = \int_0^b (1) 1/EJ dx = [x]_0^b 1/EJ$$

$$= (b) 1/EJ = b/EJ$$

$$L_{FC}^{xx} = \int_0^b (1 - 2x/b + x^2/b^2) 1/EJ dx = [x - x^2/b + 1/3 x^3/b^2]_0^b 1/EJ$$

$$= (b - b + 1/3 b) 1/EJ = 1/3 b/EJ$$

$$L_{CF}^{xx} = \int_0^b (x^2/b^2) 1/EJ dx = [1/3 x^3/b^2]_0^b 1/EJ$$

$$= (1/3 b) 1/EJ = 1/3 b/EJ$$

$$L_{EF}^{xo} = \int_0^b (-1/2 x/b) Fb 1/EJ dx + \int_0^b (1) \theta dx = [-1/4 x^2/b]_0^b Fb 1/EJ + [x]_0^b \theta$$

$$= (-1/4 b) Fb 1/EJ + (b) \theta = 3/4 Fb^2/EJ$$

$$L_{FE}^{xo} = \int_0^b (-1/2 + 1/2 x/b) Fb 1/EJ dx + \int_0^b (-1) \theta dx = [-1/2 x + 1/4 x^2/b]_0^b Fb 1/EJ + [-x]_0^b \theta$$

$$= (-1/2 b + 1/4 b) Fb 1/EJ + (-b) \theta = 3/4 Fb^2/EJ$$

$$L_{FC}^{xo} = \int_0^b (-1/2 + 1/2 x/b + 1/2 x^2/b^2 - 1/2 x^3/b^3) Fb 1/EJ dx$$

$$= [-1/2 x + 1/4 x^2/b + 1/6 x^3/b^2 - 1/8 x^4/b^3]_0^b Fb 1/EJ$$

$$= (-1/2 b + 1/4 b + 1/6 b - 1/8 b) Fb 1/EJ = -5/24 Fb^2/EJ$$

$$L_{CF}^{xo} = \int_0^b (-x^2/b^2 + 1/2 x^3/b^3) Fb 1/EJ dx = [-1/3 x^3/b^2 + 1/8 x^4/b^3]_0^b Fb 1/EJ$$

$$= (-1/3 b + 1/8 b) Fb 1/EJ = -5/24 Fb^2/EJ$$

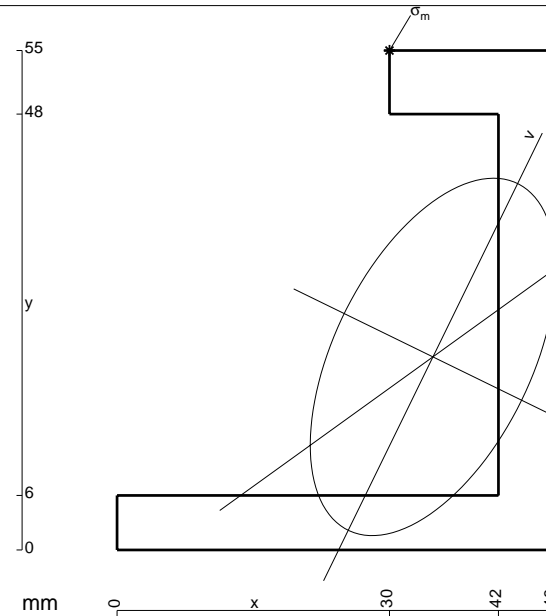

- A = 666. mm²
- J_x = 257974. mm⁴
- J_y = 121487. mm⁴
- J_{xy} = 87553. mm⁴
- J_u = 300738. mm⁴
- J_v = 78723. mm⁴
- α = arctg(2J_{xy}/(J_y-J_x))/2 = -.4544
- c = cos α = .8985
- s = sin α = -.4389
- x_g = 34.78 mm
- y_g = 21.26 mm
- N = -1500. N
- T_y = -975. N
- M_x = 1138500. Nmm
- x_m = 30. mm
- y_m = 55. mm
- u_m = -19.11 mm
- v_m = 28.22 mm
- σ_m = N/A - Mcv/J_u - Msu/J_v = -219.5 N/mm²

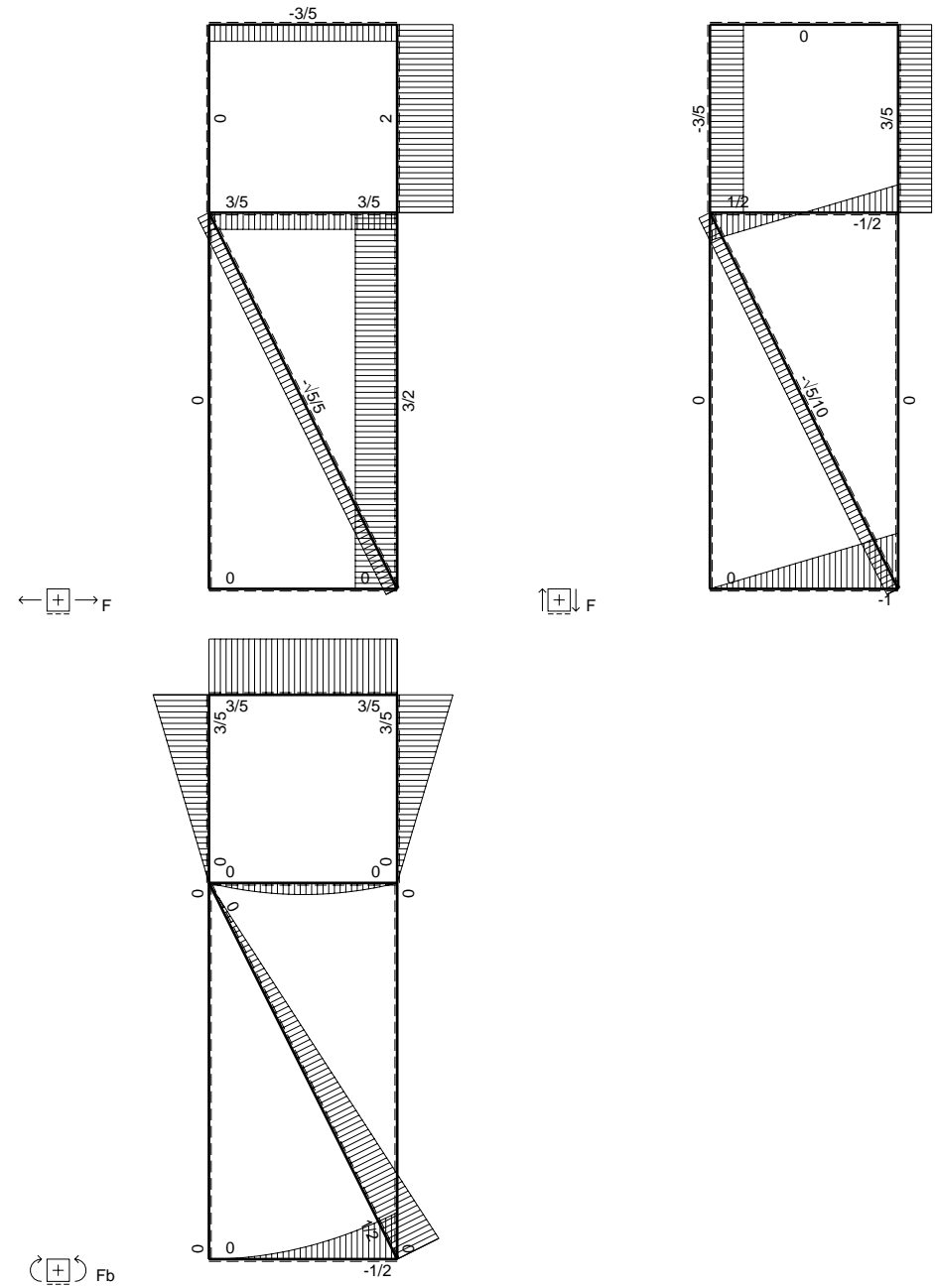
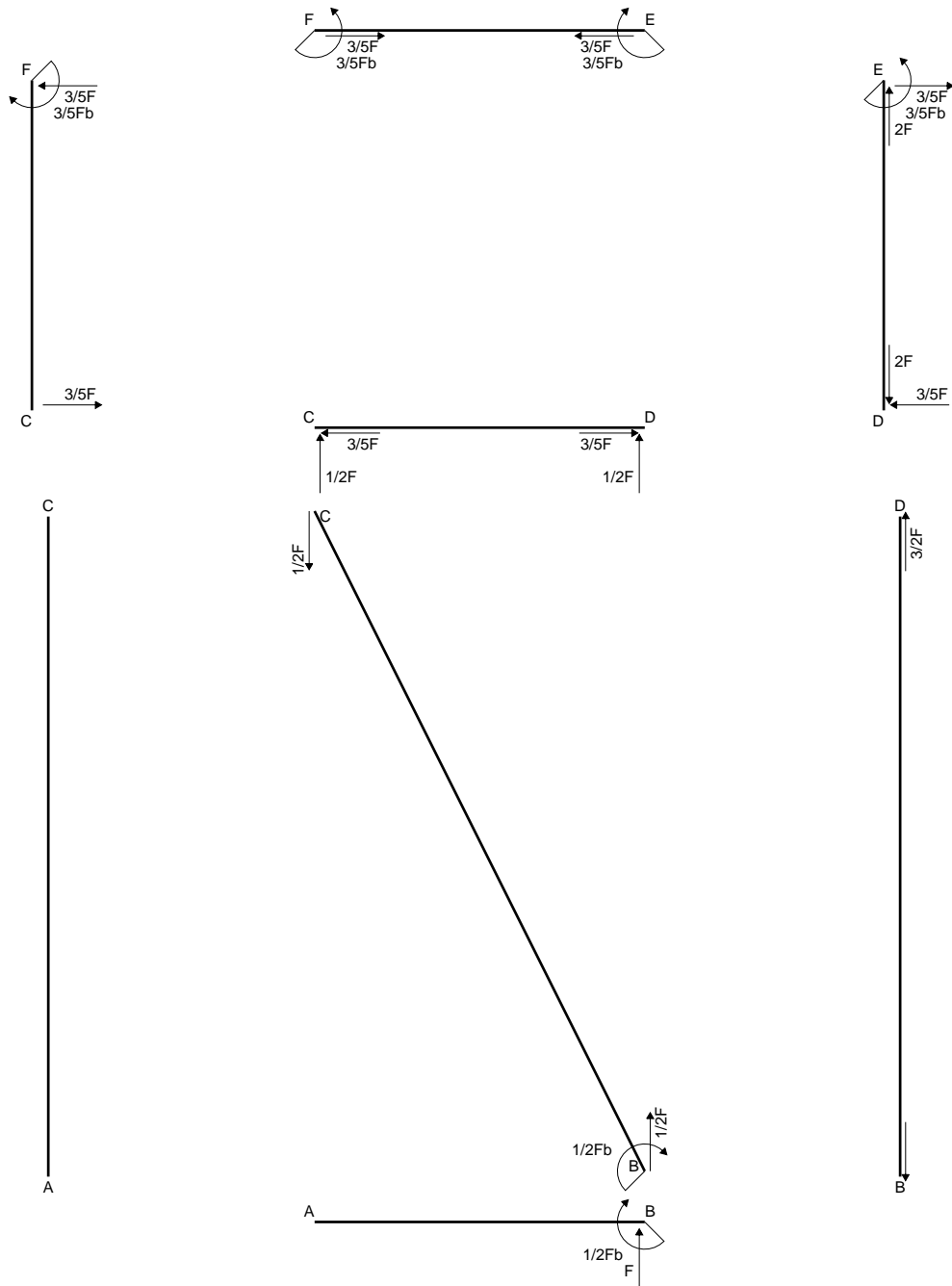

← ⊕ → F

↑ ⊕ ↓ F

⊕ ⊖ F_b

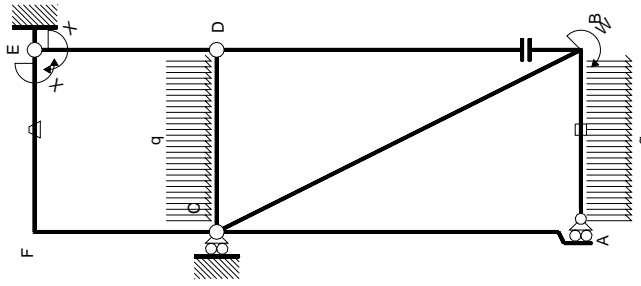

Schema di calcolo iperstatico

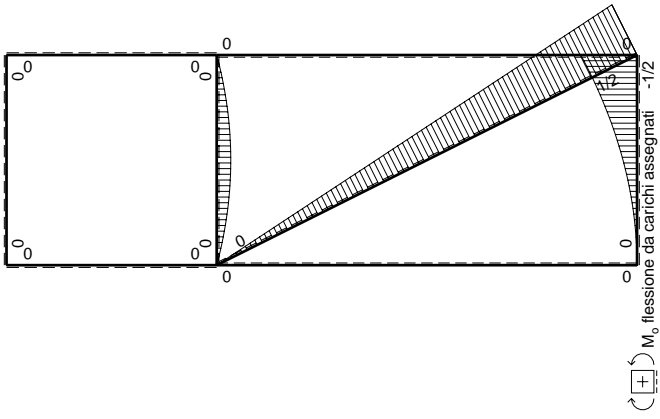

M_0 flessione da carichi assegnati -1/2

Quadro contributi PLV per iperstatica $X=W_{EF}$

\rightarrow	$M_x(x)$	$M_0(x)$	θ	$M_x M_0$	$M_x \theta$	$M_x M_x$	$\int M_x(M_0/EJ+\theta)dx$	$\int X M_x M_x / EJ dx$
AB b	0	$-1/2qx^2$	0	0	0	0	0+0	0
BA b	0	$1/2Fb-Fx+1/2qx^2$	0	0	0	0	0+0	0
BC $\sqrt{5}b$	0	$1/2Fb-\sqrt{5}/10Fx$	0	0	0	0	0	0
AC 2b	0	0	0	0	0	0	0+0	0
CA 2b	0	0	0	0	0	0	0+0	0
DB 2b	0	0	0	0	0	0	0+0	0
BD 2b	0	0	0	0	0	0	0+0	0
DE b	$-x/b$	0	0	0	0	x^2/b^2	0+0	$1/3Xb/EJ$
ED b	$1-x/b$	0	0	0	0	$1-2x/b+x^2/b^2$	0+0	$1/3Xb/EJ$
CD b	0	$1/2Fx-1/2qx^2$	0	0	0	0	0+0	0
DC b	0	$-1/2Fx+1/2qx^2$	0	0	0	0	0+0	0
EF b	-1	0	$-Fb/EJ$	0	Fb/EJ	1	$(0+1)Fb^2/EJ$	Xb/EJ
FE b	1	0	Fb/EJ	0	Fb/EJ	1	$(0+1)Fb^2/EJ$	Xb/EJ
FC b	$-1+x/b$	0	0	0	0	$1-2x/b+x^2/b^2$	0+0	$1/3Xb/EJ$
CF b	x/b	0	0	0	0	x^2/b^2	0+0	$1/3Xb/EJ$
	totali						Fb^2/EJ	$5/3Xb/EJ$
	iperstatica $X=W_{EF}$						$-3/5Fb$	

Sviluppi di calcolo iperstatica

M_x flessione da iperstatica $X=1$



$$L_{DE}^{xx} = \int_0^b (x^2/b^2) 1/EJ dx = [1/3 x^3/b^2]_0^b 1/EJ$$

$$= (1/3 b) 1/EJ = 1/3 b/EJ$$

$$L_{ED}^{xx} = \int_0^b (1 - 2x/b + x^2/b^2) 1/EJ dx = [x - x^2/b + 1/3 x^3/b^2]_0^b 1/EJ$$

$$= (b - b + 1/3 b) 1/EJ = 1/3 b/EJ$$

$$L_{EF}^{xx} = \int_0^b (1) 1/EJ dx = [x]_0^b 1/EJ$$

$$= (b) 1/EJ = b/EJ$$

$$L_{FE}^{xx} = \int_0^b (1) 1/EJ dx = [x]_0^b 1/EJ$$

$$= (b) 1/EJ = b/EJ$$

$$L_{FC}^{xx} = \int_0^b (1 - 2x/b + x^2/b^2) 1/EJ dx = [x - x^2/b + 1/3 x^3/b^2]_0^b 1/EJ$$

$$= (b - b + 1/3 b) 1/EJ = 1/3 b/EJ$$

$$L_{CF}^{xx} = \int_0^b (x^2/b^2) 1/EJ dx = [1/3 x^3/b^2]_0^b 1/EJ$$

$$= (1/3 b) 1/EJ = 1/3 b/EJ$$

$$L_{EF}^{xo} = \int_0^b (1) \theta dx = [x]_0^b \theta$$

$$= (b) \theta = Fb^2/EJ$$

$$L_{FE}^{xo} = \int_0^b (-1) \theta dx = [-x]_0^b \theta$$

$$= (-b) \theta = Fb^2/EJ$$

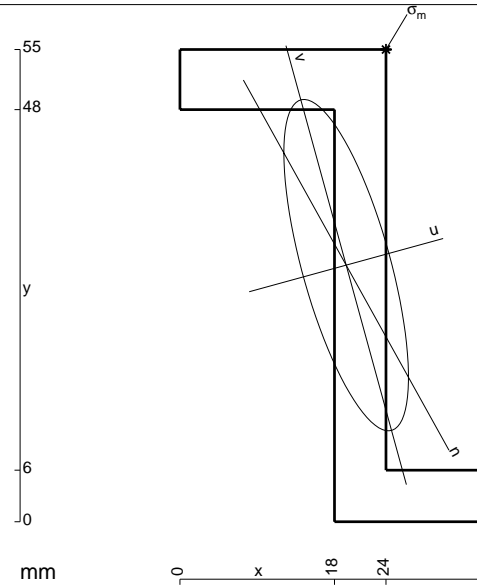

$A = 528. \text{ mm}^2$
 $J_x = 196705. \text{ mm}^4$
 $J_y = 27818. \text{ mm}^4$
 $J_{xy} = -50102. \text{ mm}^4$
 $J_u = 210450. \text{ mm}^4$
 $J_v = 14073. \text{ mm}^4$
 $\alpha = \text{artg}(2J_{xy}/(J_y - J_x))/2 = .2677$
 $c = \cos\alpha = .9644$
 $s = \sin\alpha = .2646$
 $x_g = 19.36 \text{ mm}$
 $y_g = 29.89 \text{ mm}$
 $N = -1446. \text{ N}$
 $M_x = 723000. \text{ Nmm}$
 $x_m = 24. \text{ mm}$
 $y_m = 55. \text{ mm}$
 $u_m = 11.12 \text{ mm}$
 $v_m = 22.99 \text{ mm}$
 $\sigma_m = N/A - Mcv/J_u - Msu/J_v = -230. \text{ N/mm}^2$

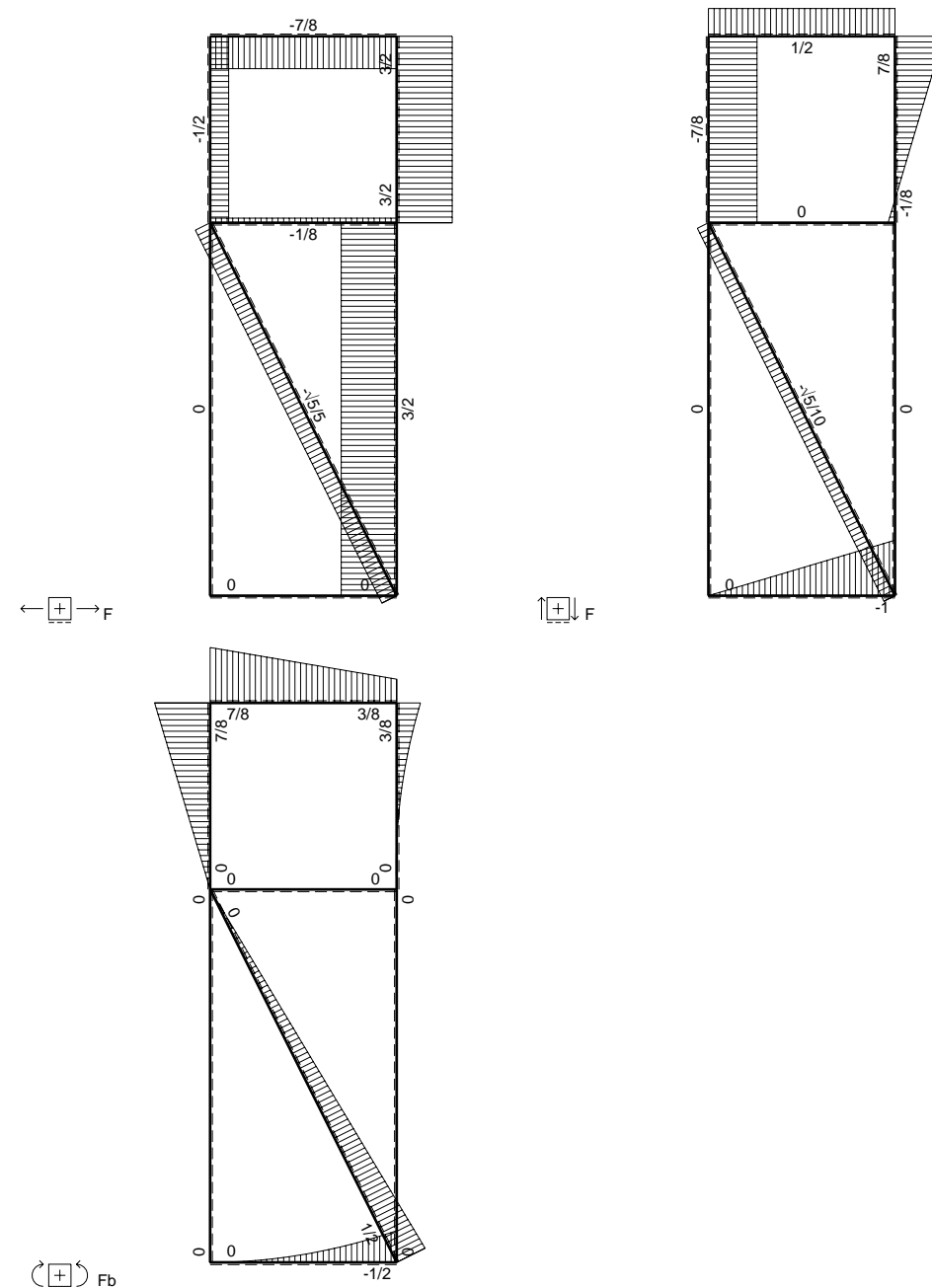
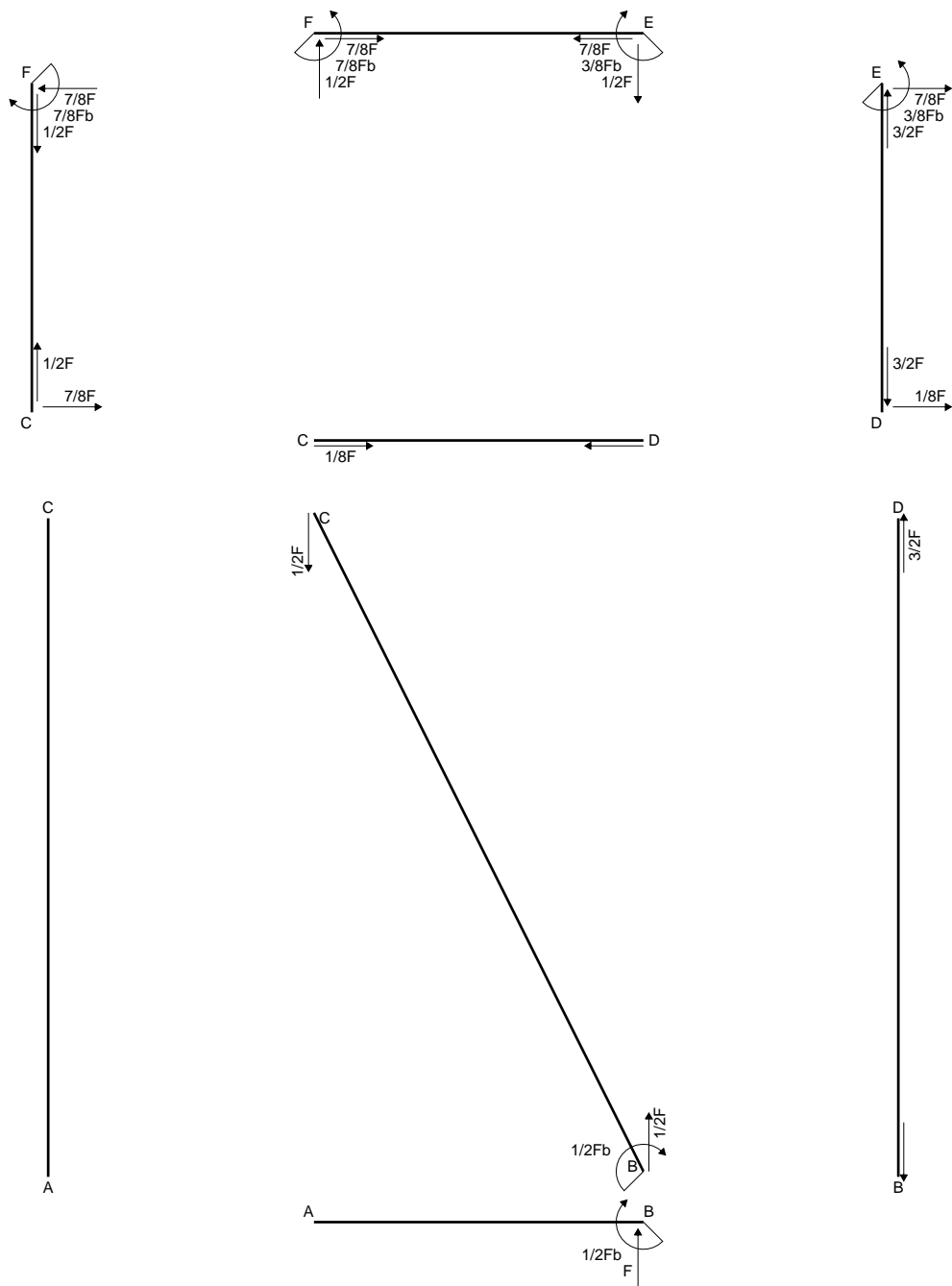

$$L_{DE}^{xx} = \int_0^b (x^2/b^2) 1/EJ dx = [1/3 x^3/b^2]_0^b 1/EJ$$

$$= (1/3 b) 1/EJ = 1/3 b/EJ$$

$$L_{ED}^{xx} = \int_0^b (1 - 2x/b + x^2/b^2) 1/EJ dx = [x - x^2/b + 1/3 x^3/b^2]_0^b 1/EJ$$

$$= (b - b + 1/3 b) 1/EJ = 1/3 b/EJ$$

$$L_{EF}^{xx} = \int_0^b (1) 1/EJ dx = [x]_0^b 1/EJ$$

$$= (b) 1/EJ = b/EJ$$

$$L_{FE}^{xx} = \int_0^b (1) 1/EJ dx = [x]_0^b 1/EJ$$

$$= (b) 1/EJ = b/EJ$$

$$L_{FC}^{xx} = \int_0^b (1 - 2x/b + x^2/b^2) 1/EJ dx = [x - x^2/b + 1/3 x^3/b^2]_0^b 1/EJ$$

$$= (b - b + 1/3 b) 1/EJ = 1/3 b/EJ$$

$$L_{CF}^{xx} = \int_0^b (x^2/b^2) 1/EJ dx = [1/3 x^3/b^2]_0^b 1/EJ$$

$$= (1/3 b) 1/EJ = 1/3 b/EJ$$

$$L_{DE}^{xo} = \int_0^b (1/2 x^2/b^2 - 1/2 x^3/b^3) Fb 1/EJ dx = [1/6 x^3/b^2 - 1/8 x^4/b^3]_0^b Fb 1/EJ$$

$$= (1/6 b - 1/8 b) Fb 1/EJ = 1/24 Fb^2/EJ$$

$$L_{ED}^{xo} = \int_0^b (1/2 x/b - x^2/b^2 + 1/2 x^3/b^3) Fb 1/EJ dx = [1/4 x^2/b - 1/3 x^3/b^2 + 1/8 x^4/b^3]_0^b Fb 1/EJ$$

$$= (1/4 b - 1/3 b + 1/8 b) Fb 1/EJ = 1/24 Fb^2/EJ$$

$$L_{EF}^{xo} = \int_0^b (-1/2 x/b) Fb 1/EJ dx + \int_0^b (1) \theta dx = [-1/4 x^2/b]_0^b Fb 1/EJ + [x]_0^b \theta$$

$$= (-1/4 b) Fb 1/EJ + (b) \theta = 3/4 Fb^2/EJ$$

$$L_{FE}^{xo} = \int_0^b (-1/2 + 1/2 x/b) Fb 1/EJ dx + \int_0^b (-1) \theta dx = [-1/2 x + 1/4 x^2/b]_0^b Fb 1/EJ + [-x]_0^b \theta$$

$$= (-1/2 b + 1/4 b) Fb 1/EJ + (-b) \theta = 3/4 Fb^2/EJ$$

$$L_{FC}^{xo} = \int_0^b (-1/2 + x/b - 1/2 x^2/b^2) Fb 1/EJ dx = [-1/2 x + 1/2 x^2/b - 1/6 x^3/b^2]_0^b Fb 1/EJ$$

$$= (-1/2 b + 1/2 b - 1/6 b) Fb 1/EJ = -1/6 Fb^2/EJ$$

$$L_{CF}^{xo} = \int_0^b (-1/2 x^2/b^2) Fb 1/EJ dx = [-1/6 x^3/b^2]_0^b Fb 1/EJ$$

$$= (-1/6 b) Fb 1/EJ = -1/6 Fb^2/EJ$$

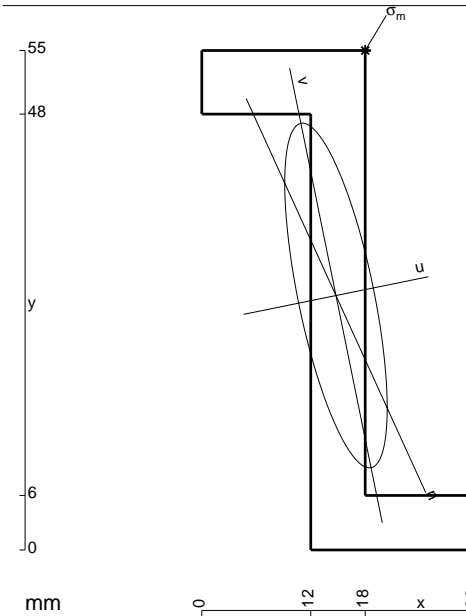

- A = 486. mm²
- J_x = 175218. mm⁴
- J_y = 15474. mm⁴
- J_{xy} = -33964. mm⁴
- J_u = 182139. mm⁴
- J_v = 8553. mm⁴
- α = arctg(2J_{xy}/(J_y-J_x))/2 = .2010
- c = cos α = .9799
- s = sin α = .1997
- x_g = 14.78 mm
- y_g = 28.02 mm
- N = -1295. N
- T_y = 740. N
- M_x = 699300. Nmm
- x_m = 18. mm
- y_m = 55. mm
- u_m = 8.545 mm
- v_m = 25.79 mm
- σ_m = N/A - Mcv/J_u - Msu/J_v = -239.2 N/mm²

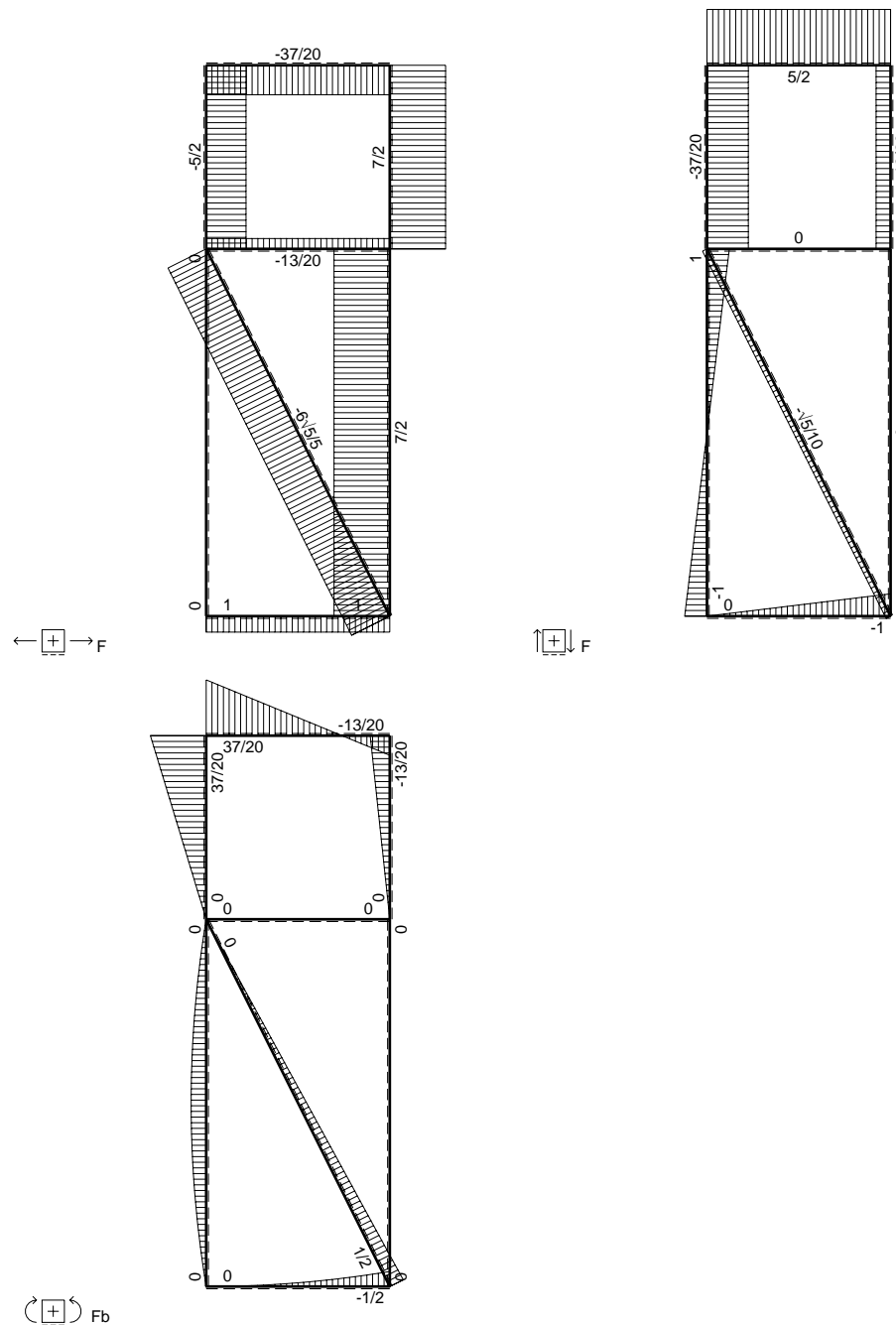
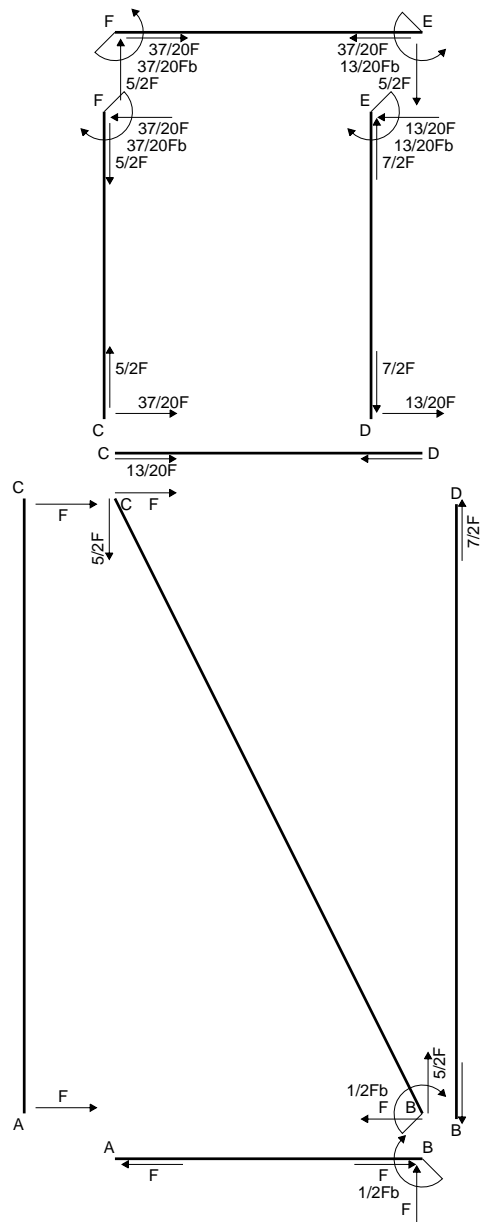

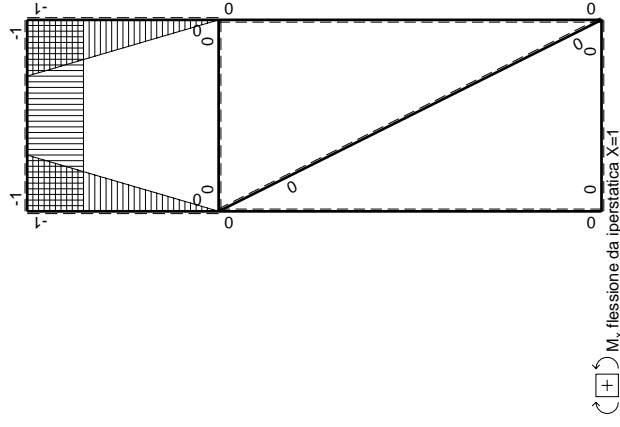
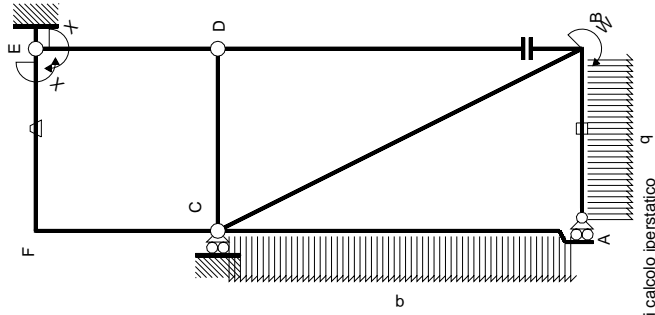

Quadro contributi PLV per iperstatica $X=W_{EP}$

\rightarrow	$M(x)$	$M_0(x)$	M_θ	M_x	$\int M_x(M_0/EJ+\theta)dx$	$\int M_x M_0/EJdx$
AB b	0	0	0	0	0	0
BA b	0	$1/2Fb-Fx+1/2qx^2$	0	0	0	0
BC $\sqrt{5}b$	0	$1/2Fb-\sqrt{5}/10Fx$	0	0	0	0
AC 2b	0	$-Fx+1/2qx^2$	0	0	0	0
CA 2b	0	$Fx-1/2qx^2$	0	0	0	0
DB 2b	0	0	0	0	0	0
BD 2b	0	0	0	0	0	0
DE b	-x/b	0	0	x^2/b^2	0	0
ED b	1-x/b	0	0	$1-2x/b+x^2/b^2$	0	0
CD b	0	0	0	0	0	0
DC b	0	0	0	0	0	0
EF b	-1	$5/2Fx$	Fb/EJ	1	$(-5/4+1)Fb^2/EJ$	Xb/EJ
FE b	1	$-5/2Fb+5/2Fx$	Fb/EJ	1	$(-5/4+1)Fb^2/EJ$	$1/3Xb/EJ$
FC b	-1+x/b	$5/2Fb-5/2Fx$	0	$1-2x/b+x^2/b^2$	$(-5/6+0)Fb^2/EJ$	$1/3Xb/EJ$
CF b	x/b	$-5/2Fx$	0	x^2/b^2	$-13/12Fb^2/EJ$	$5/3Xb/EJ$
totali						
iperstatica $X=W_{EP}$						

Sviluppi di calcolo iperstatica

$$L_{DE}^{xx} = \int_0^b (x^2/b^2) 1/EJ dx = [1/3 x^3/b^2]_0^b 1/EJ$$

$$= (1/3 b) 1/EJ = 1/3 b/EJ$$

$$L_{ED}^{xx} = \int_0^b (1 - 2x/b + x^2/b^2) 1/EJ dx = [x - x^2/b + 1/3 x^3/b^2]_0^b 1/EJ$$

$$= (b - b + 1/3 b) 1/EJ = 1/3 b/EJ$$

$$L_{EF}^{xx} = \int_0^b (1) 1/EJ dx = [x]_0^b 1/EJ$$

$$= (b) 1/EJ = b/EJ$$

$$L_{FE}^{xx} = \int_0^b (1) 1/EJ dx = [x]_0^b 1/EJ$$

$$= (b) 1/EJ = b/EJ$$

$$L_{FC}^{xx} = \int_0^b (-2x/b + x^2/b^2) 1/EJ dx = [-x^2/b + 1/3 x^3/b^2]_0^b 1/EJ$$

$$= (b - b + 1/3 b) 1/EJ = 1/3 b/EJ$$

$$L_{CF}^{xx} = \int_0^b (x^2/b^2) 1/EJ dx = [1/3 x^3/b^2]_0^b 1/EJ$$

$$= (1/3 b) 1/EJ = 1/3 b/EJ$$

$$L_{EF}^{xo} = \int_0^b (-5/2 x/b) Fb 1/EJ dx + \int_0^b (1) \theta dx = [-5/4 x^2/b]_0^b Fb 1/EJ + [x]_0^b \theta$$

$$= (-5/4 b) Fb 1/EJ + (b) \theta = -1/4 Fb^2/EJ$$

$$L_{FE}^{xo} = \int_0^b (-5/2 + 5/2 x/b) Fb 1/EJ dx + \int_0^b (-1) \theta dx = [-5/2 x + 5/4 x^2/b]_0^b Fb 1/EJ + [-x]_0^b \theta$$

$$= (-5/2 b + 5/4 b) Fb 1/EJ + (-b) \theta = -1/4 Fb^2/EJ$$

$$L_{FC}^{xo} = \int_0^b (-5/2 + 5x/b - 5/2 x^2/b^2) Fb 1/EJ dx = [-5/2 x + 5/2 x^2/b - 5/6 x^3/b^2]_0^b Fb 1/EJ$$

$$= (-5/2 b + 5/2 b - 5/6 b) Fb 1/EJ = -5/6 Fb^2/EJ$$

$$L_{CF}^{xo} = \int_0^b (-5/2 x^2/b^2) Fb 1/EJ dx = [-5/6 x^3/b^2]_0^b Fb 1/EJ$$

$$= (-5/6 b) Fb 1/EJ = -5/6 Fb^2/EJ$$

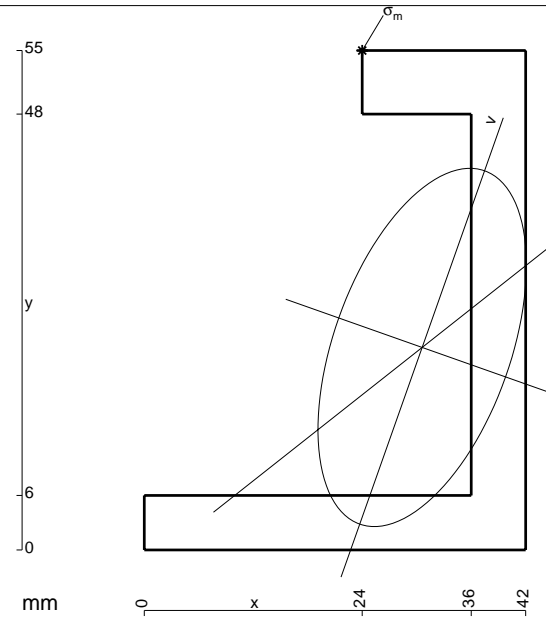

- A = 630. mm²
- J_x = 245181. mm⁴
- J_y = 82933. mm⁴
- J_{xy} = 65470. mm⁴
- J_u = 268304. mm⁴
- J_v = 59811. mm⁴
- α = arctg(2J_{xy}/(J_y-J_x))/2 = -.3395
- c = cos α = .9429
- s = sin α = -.3330
- x_g = 30.6 mm
- y_g = 22.3 mm
- N = -2325. N
- T_y = -1721. N
- M_x = 997890. Nmm
- x_m = 24. mm
- y_m = 55. mm
- u_m = -17.11 mm
- v_m = 28.64 mm
- σ_m = N/A-Mcv/J_u-Msu/J_v = -199.2 N/mm²

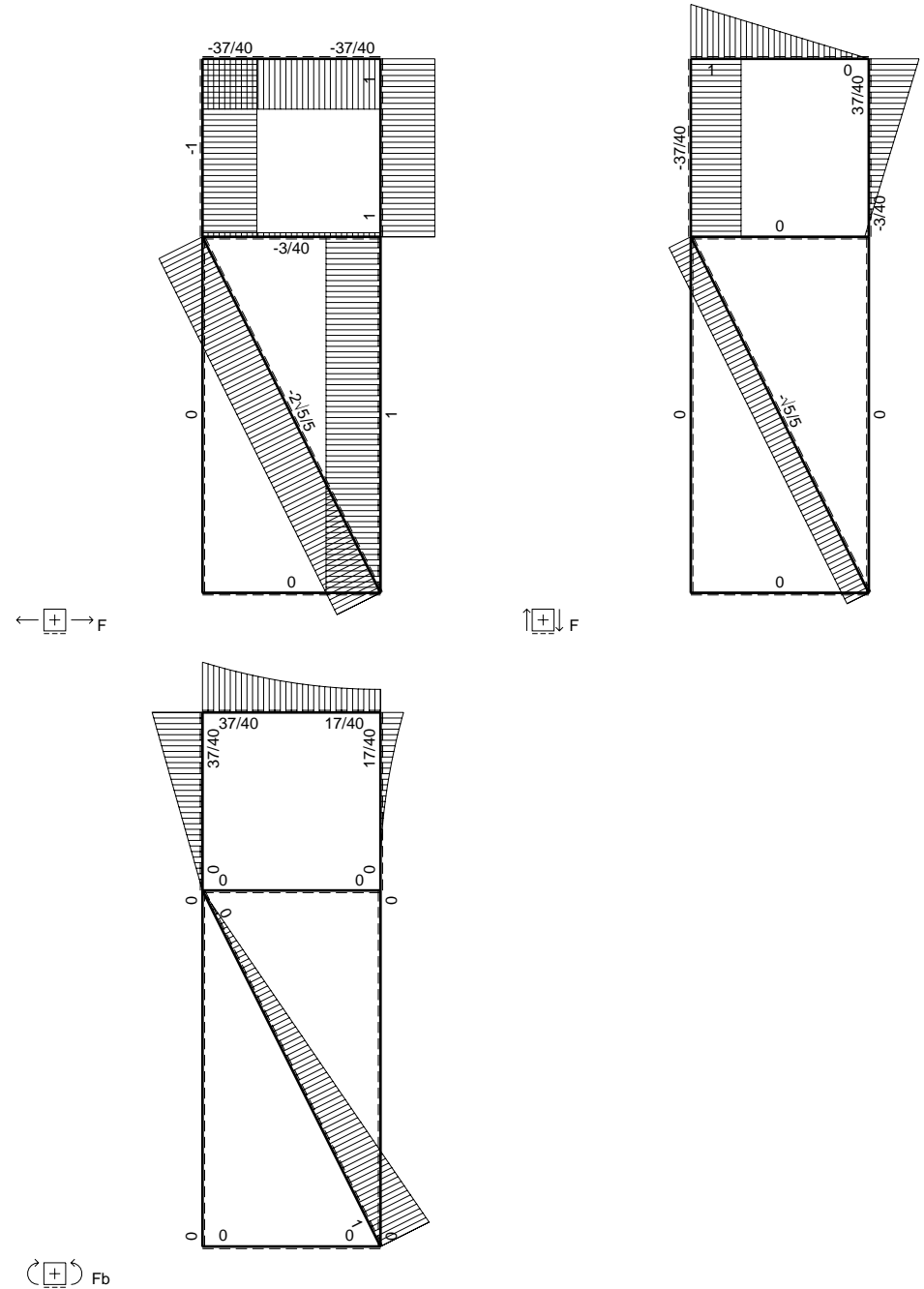
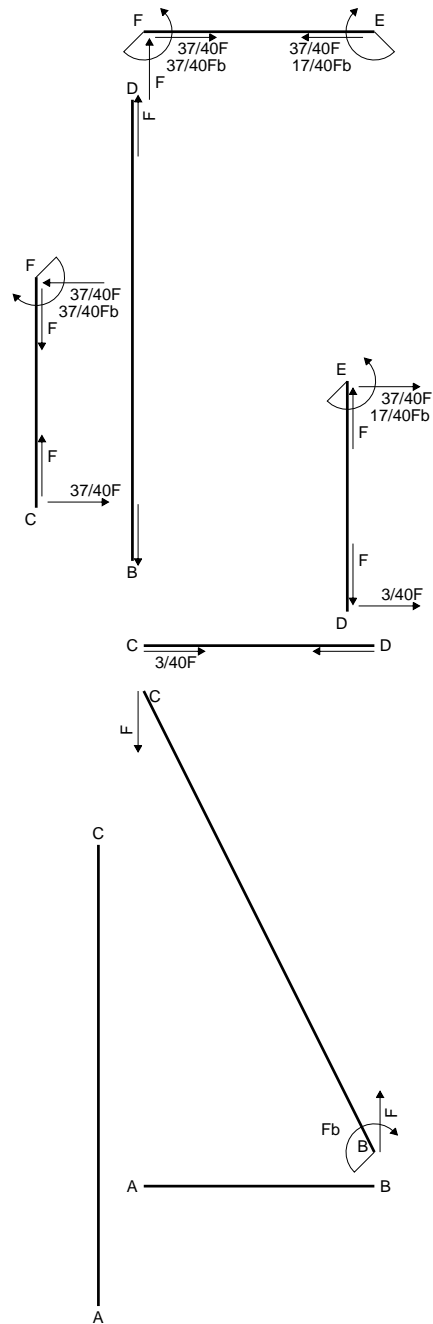

← ⊕ → F

⊕ ↻ F_b

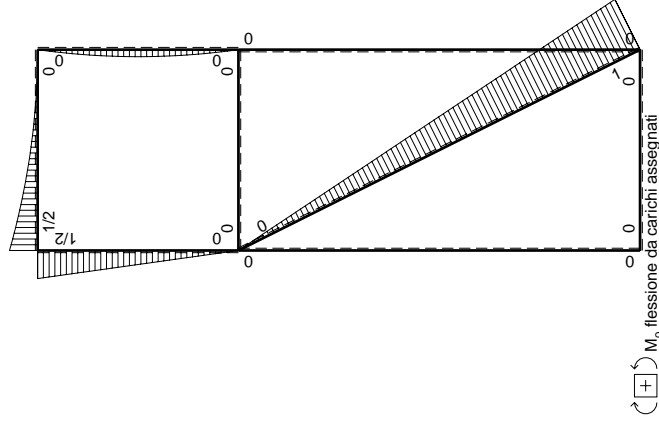
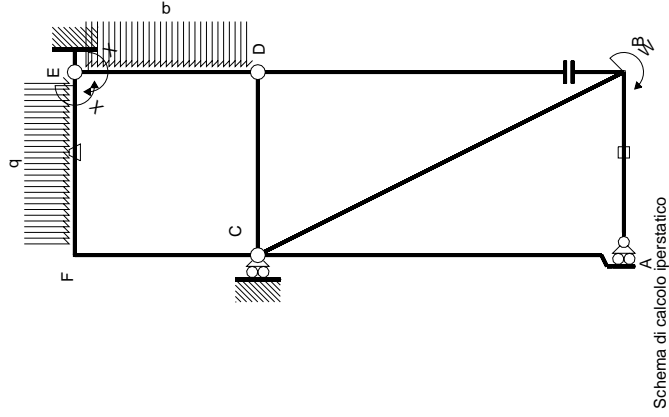

Quadro contributi PLV per iperstatica $X=W_{EF}$		$M^x(x)$	$M^0(x)$	θ	$M^x M_0$	$M^x \theta$	$M^x M_x$	$\int M^x (M_0/EJ + \theta) dx$	$\int M^x M_x / E J dx$
AB b	0	0	0	0	0	0	0	0	0
BA b	0	0	0	0	0	0	0	0	0
BC $\sqrt{5}b$	0	$Fb\sqrt{5}/5Fx$	0	0	0	0	0	0	0
AC 2b	0	0	0	0	0	0	0	0	0
CA 2b	0	0	0	0	0	0	0	0	0
DB 2b	0	0	0	0	0	0	0	0	0
BD 2b	0	0	0	0	0	0	0	0	0
DE b	-x/b	$-1/2Fx + 1/2qx^2$	0	0	$1/2Fx^2/b - 1/2qx^3/b$	0	0	x^2/b^2	0
ED b	1-x/b	$1/2Fx - 1/2qx^2$	0	0	$1/2Fx - Fx^2/b + 1/2qx^3/b$	0	0	$1-2x/b+x^2/b^2$	$(1/24+0)Fb^2/EJ$
CD b	0	0	0	0	0	0	0	0	0
DC b	0	0	0	0	0	0	0	0	0
EF b	-1	$1/2qx^2$	-Fb/EJ	-Fb/EJ	$-1/2Fx^2/b$	Fb/EJ	1	1	$(-1/6+1)Fb^2/EJ$
FE b	1	$-1/2Fb+Fx-1/2qx^2$	Fb/EJ	-Fb/EJ	$-1/2Fb+Fx-1/2Fx^2/b$	Fb/EJ	1	1	$(-1/6+0)Fb^2/EJ$
FC b	-1+x/b	$1/2Fb-1/2Fx$	0	0	$-1/2Fb+Fx-1/2Fx^2/b$	0	0	x^2/b^2	$1/3xb/EJ$
CF b	x/b	-1/2Fx	0	0	$-1/2Fx^2/b$	0	0	x^2/b^2	$1/3xb/EJ$
totali									$17/24Fb^2/EJ$
									$-17/40Fb$

Sviluppi di calcolo iperstatica

$$L_{DE}^{xx} = \int_0^b (x^2/b^2) 1/EJ dx = [1/3 x^3/b^2]_0^b 1/EJ$$

$$= (1/3 b) 1/EJ = 1/3 b/EJ$$

$$L_{ED}^{xx} = \int_0^b (1 - 2x/b + x^2/b^2) 1/EJ dx = [x - x^2/b + 1/3 x^3/b^2]_0^b 1/EJ$$

$$= (b - b + 1/3 b) 1/EJ = 1/3 b/EJ$$

$$L_{EF}^{xx} = \int_0^b (1) 1/EJ dx = [x]_0^b 1/EJ$$

$$= (b) 1/EJ = b/EJ$$

$$L_{FE}^{xx} = \int_0^b (1) 1/EJ dx = [x]_0^b 1/EJ$$

$$= (b) 1/EJ = b/EJ$$

$$L_{FC}^{xx} = \int_0^b (1 - 2x/b + x^2/b^2) 1/EJ dx = [x - x^2/b + 1/3 x^3/b^2]_0^b 1/EJ$$

$$= (b - b + 1/3 b) 1/EJ = 1/3 b/EJ$$

$$L_{CF}^{xx} = \int_0^b (x^2/b^2) 1/EJ dx = [1/3 x^3/b^2]_0^b 1/EJ$$

$$= (1/3 b) 1/EJ = 1/3 b/EJ$$

$$L_{DE}^{xo} = \int_0^b (1/2 x^2/b^2 - 1/2 x^3/b^3) Fb 1/EJ dx = [1/6 x^3/b^2 - 1/8 x^4/b^3]_0^b Fb 1/EJ$$

$$= (1/6 b - 1/8 b) Fb 1/EJ = 1/24 Fb^2/EJ$$

$$L_{ED}^{xo} = \int_0^b (1/2 x/b - x^2/b^2 + 1/2 x^3/b^3) Fb 1/EJ dx = [1/4 x^2/b - 1/3 x^3/b^2 + 1/8 x^4/b^3]_0^b Fb 1/EJ$$

$$= (1/4 b - 1/3 b + 1/8 b) Fb 1/EJ = 1/24 Fb^2/EJ$$

$$L_{EF}^{xo} = \int_0^b (-1/2 x^2/b^2) Fb 1/EJ dx + \int_0^b (1) \theta dx = [-1/6 x^3/b^2]_0^b Fb 1/EJ + [x]_0^b \theta$$

$$= (-1/6 b) Fb 1/EJ + (b) \theta = 5/6 Fb^2/EJ$$

$$L_{FE}^{xo} = \int_0^b (-1/2 + x/b - 1/2 x^2/b^2) Fb 1/EJ dx + \int_0^b (-1) \theta dx$$

$$= [-1/2 x + 1/2 x^2/b - 1/6 x^3/b^2]_0^b Fb 1/EJ + [-x]_0^b \theta$$

$$= (-1/2 b + 1/2 b - 1/6 b) Fb 1/EJ + (-b) \theta = 5/6 Fb^2/EJ$$

$$L_{FC}^{xo} = \int_0^b (-1/2 + x/b - 1/2 x^2/b^2) Fb 1/EJ dx = [-1/2 x + 1/2 x^2/b - 1/6 x^3/b^2]_0^b Fb 1/EJ$$

$$= (-1/2 b + 1/2 b - 1/6 b) Fb 1/EJ = -1/6 Fb^2/EJ$$

$$L_{CF}^{xo} = \int_0^b (-1/2 x^2/b^2) Fb 1/EJ dx = [-1/6 x^3/b^2]_0^b Fb 1/EJ$$

$$= (-1/6 b) Fb 1/EJ = -1/6 Fb^2/EJ$$

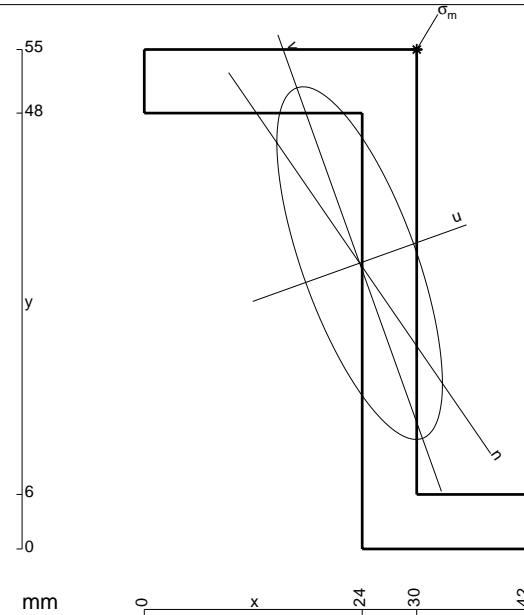

- A = 570. mm²
- J_x = 215051. mm⁴
- J_y = 47402. mm⁴
- J_{xy} = -68907. mm⁴
- J_u = 239738. mm⁴
- J_v = 22715. mm⁴
- α = arctg(2J_{xy}/(J_y-J_x))/2 = .3440
- c = cos α = .9414
- s = sin α = .3373
- x_g = 23.72 mm
- y_g = 31.48 mm
- N = -1055. N
- T_y = -527.7 N
- M_x = 731600. Nmm
- x_m = 30. mm
- y_m = 55. mm
- u_m = 13.85 mm
- v_m = 20.02 mm
- σ_m = N/A - Mc_v/J_u - Ms_u/J_v = -209.8 N/mm²

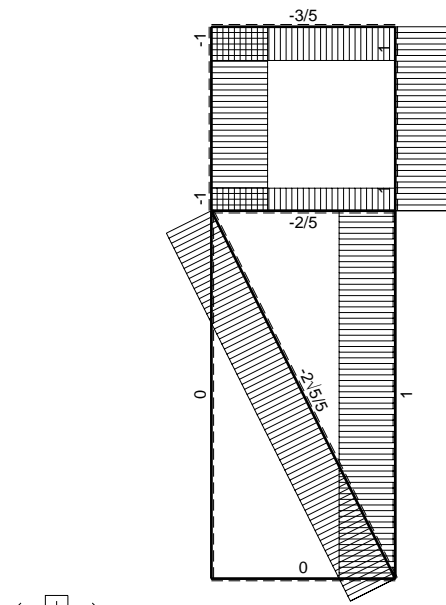
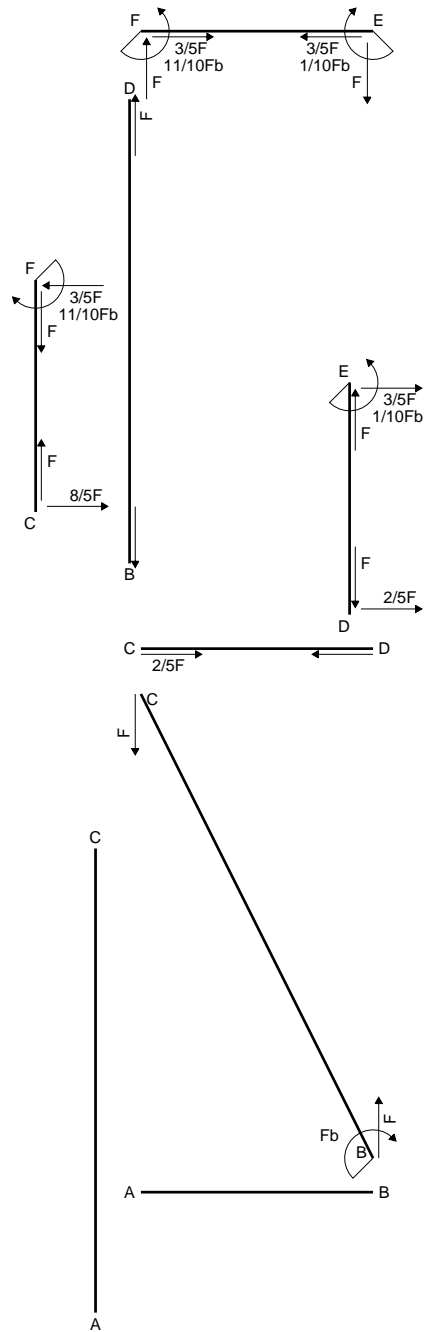

← ⊕ → F

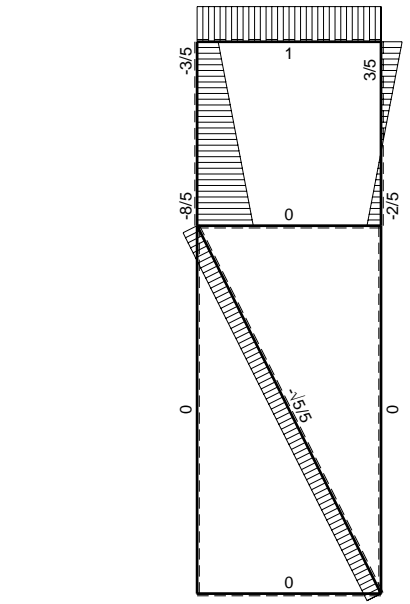

↑ ⊕ ↓ F

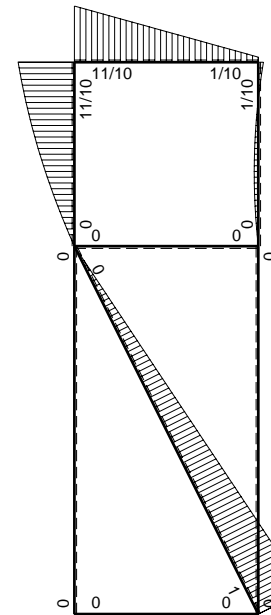

⊕ F_b

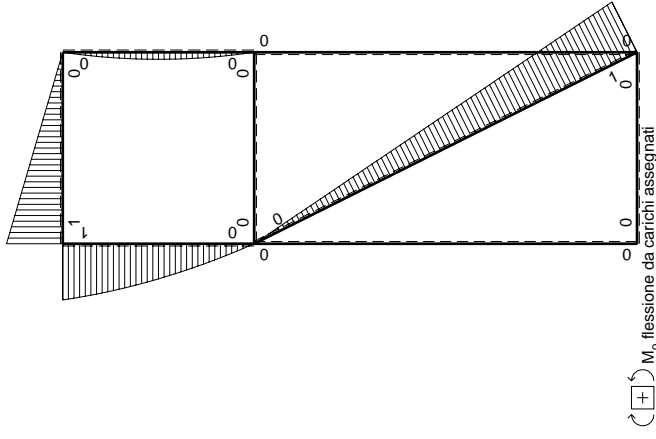
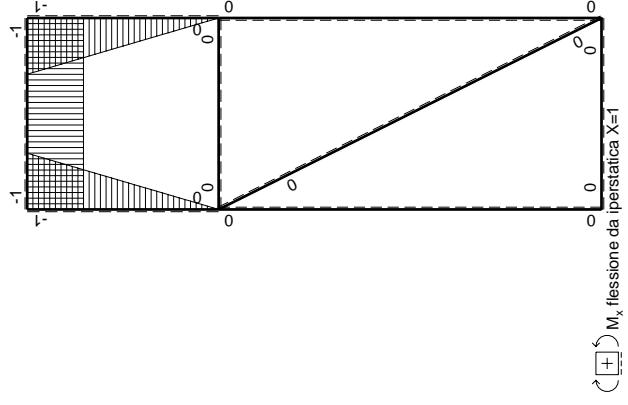
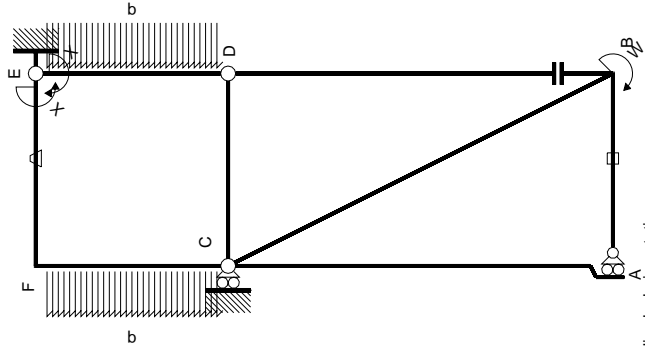

←	$M(x)$		$M_0(x)$		M_θ		M_x		$\int M_x(M_0/EJ+\theta)dx$		$\int M_x M_0/EJ dx$		
	AB	BC	CA	DB	BD	DE	ED	DC	CD	DB	BC	CA	
AB	0	0	0	0	0	0	0	0	0	0+0	0	0	
BA	0	0	0	0	0	0	0	0	0	0	0	0	
BC	0	$Fb-\sqrt{5}/5Fx$	0	0	0	0	0	0	0	0+0	0	0	
CA	0	0	0	0	0	0	0	0	0	0+0	0	0	
DB	0	0	0	0	0	0	0	0	0	0+0	0	0	
DE	$-x/b$	$-1/2Fx+1/2qx^2$	0	$1/2Fx^2/b-1/2qx^3/b$	0	$1/2Fx^2/b+1/2qx^3/b$	0	x^2/b^2	$(1/24+0)Fb^2/EJ$	0	$1/3xb/EJ$	0	
ED	$1-x/b$	$1/2Fx-1/2qx^2$	0	$1/2Fx-Fx^2/b+1/2qx^3/b$	0	$1-2x/b+x^2/b^2$	0	x^2/b^2	$(1/24+0)Fb^2/EJ$	0	$1/3xb/EJ$	0	
CD	0	0	0	0	0	0	0	0	0+0	0	0	0	
DC	0	0	0	0	0	0	0	0	0+0	0	0	0	
EF	-1	Fx	-Fb/EJ	-Fx	Fb/EJ	1	$(-1/2+1)Fb^2/EJ$	x^2/b^2	$(-3/8+0)Fb^2/EJ$	0	$1/3xb/EJ$	0	
FE	1	-Fb+Fx	Fb/EJ	-Fb+Fx	Fb/EJ	1	$(-1/2+1)Fb^2/EJ$	x^2/b^2	$(-3/8+0)Fb^2/EJ$	0	$1/3xb/EJ$	0	
FC	$-1+x/b$	$Fb-1/2Fx-1/2qx^2$	0	$-Fb+3/2Fx-1/2qx^3/b$	0	$1-2x/b+x^2/b^2$	0	x^2/b^2	$(-3/8+0)Fb^2/EJ$	0	$1/3xb/EJ$	0	
CF	x/b	$-3/2Fx+1/2qx^2$	0	$-3/2Fx^2/b+1/2qx^3/b$	0	x^2/b^2	0	x^2/b^2	$1/6Fb^2/EJ$	0	$5/3xb/EJ$	0	
totali													
iperstatica $X=W_{EF}$													

Sviluppi di calcolo iperstatica

$$L_{DE}^{xx} = \int_0^b (x^2/b^2) 1/EJ dx = [1/3 x^3/b^2]_0^b 1/EJ$$

$$= (1/3 b) 1/EJ = 1/3 b/EJ$$

$$L_{ED}^{xx} = \int_0^b (1 - 2x/b + x^2/b^2) 1/EJ dx = [x - x^2/b + 1/3 x^3/b^2]_0^b 1/EJ$$

$$= (b - b + 1/3 b) 1/EJ = 1/3 b/EJ$$

$$L_{EF}^{xx} = \int_0^b (1) 1/EJ dx = [x]_0^b 1/EJ$$

$$= (b) 1/EJ = b/EJ$$

$$L_{FE}^{xx} = \int_0^b (1) 1/EJ dx = [x]_0^b 1/EJ$$

$$= (b) 1/EJ = b/EJ$$

$$L_{FC}^{xx} = \int_0^b (1 - 2x/b + x^2/b^2) 1/EJ dx = [x - x^2/b + 1/3 x^3/b^2]_0^b 1/EJ$$

$$= (b - b + 1/3 b) 1/EJ = 1/3 b/EJ$$

$$L_{CF}^{xx} = \int_0^b (x^2/b^2) 1/EJ dx = [1/3 x^3/b^2]_0^b 1/EJ$$

$$= (1/3 b) 1/EJ = 1/3 b/EJ$$

$$L_{DE}^{xo} = \int_0^b (1/2 x^2/b^2 - 1/2 x^3/b^3) Fb 1/EJ dx = [1/6 x^3/b^2 - 1/8 x^4/b^3]_0^b Fb 1/EJ$$

$$= (1/6 b - 1/8 b) Fb 1/EJ = 1/24 Fb^2/EJ$$

$$L_{ED}^{xo} = \int_0^b (1/2 x/b - x^2/b^2 + 1/2 x^3/b^3) Fb 1/EJ dx = [1/4 x^2/b - 1/3 x^3/b^2 + 1/8 x^4/b^3]_0^b Fb 1/EJ$$

$$= (1/4 b - 1/3 b + 1/8 b) Fb 1/EJ = 1/24 Fb^2/EJ$$

$$L_{EF}^{xo} = \int_0^b (-x/b) Fb 1/EJ dx + \int_0^b (1) \theta dx = [-1/2 x^2/b]_0^b Fb 1/EJ + [x]_0^b \theta$$

$$= (-1/2 b) Fb 1/EJ + (b) \theta = 1/2 Fb^2/EJ$$

$$L_{FE}^{xo} = \int_0^b (-1 + x/b) Fb 1/EJ dx + \int_0^b (-1) \theta dx = [-x + 1/2 x^2/b]_0^b Fb 1/EJ + [-x]_0^b \theta$$

$$= (-b + 1/2 b) Fb 1/EJ + (-b) \theta = 1/2 Fb^2/EJ$$

$$L_{FC}^{xo} = \int_0^b (-1 + 3/2 x/b - 1/2 x^3/b^3) Fb 1/EJ dx = [-x + 3/4 x^2/b - 1/8 x^4/b^3]_0^b Fb 1/EJ$$

$$= (-b + 3/4 b - 1/8 b) Fb 1/EJ = -3/8 Fb^2/EJ$$

$$L_{CF}^{xo} = \int_0^b (-3/2 x^2/b^2 + 1/2 x^3/b^3) Fb 1/EJ dx = [-1/2 x^3/b^2 + 1/8 x^4/b^3]_0^b Fb 1/EJ$$

$$= (-1/2 b + 1/8 b) Fb 1/EJ = -3/8 Fb^2/EJ$$

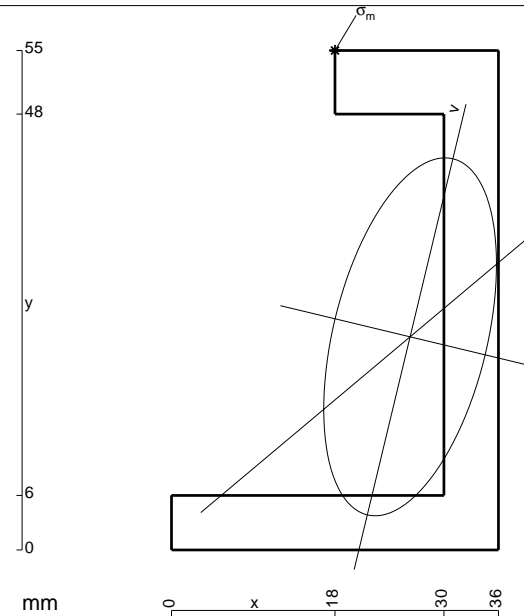

- A = 594. mm²
- J_x = 230851. mm⁴
- J_y = 53740. mm⁴
- J_{xy} = 45131. mm⁴
- J_u = 241688. mm⁴
- J_v = 42903. mm⁴
- α = arctg(2J_{xy}/(J_y-J_x))/2 = -.2357
- c = cos α = .9724
- s = sin α = -.2335
- x_g = 26.27 mm
- y_g = 23.47 mm
- N = -1500. N
- T_y = -900. N
- M_x = 1089000. Nmm
- x_m = 18. mm
- y_m = 55. mm
- u_m = -15.41 mm
- v_m = 28.73 mm
- σ_m = N/A - Mc_v/J_u - Ms_u/J_v = -219.7 N/mm²

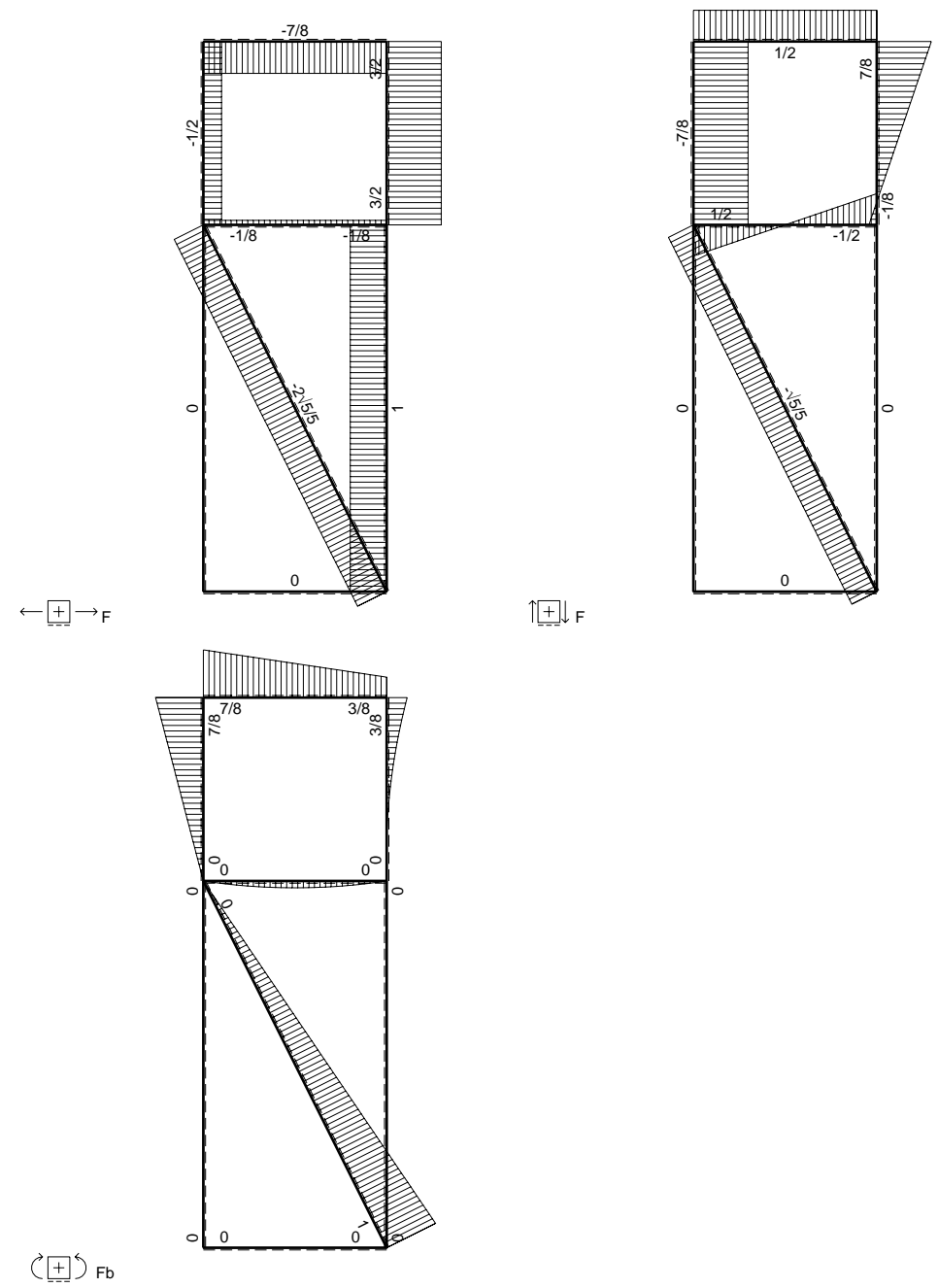
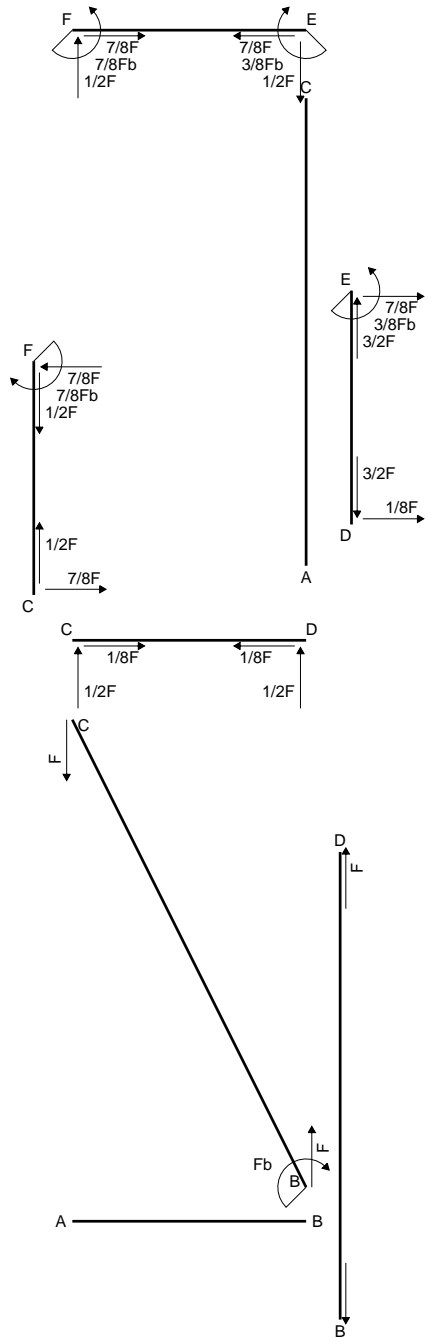

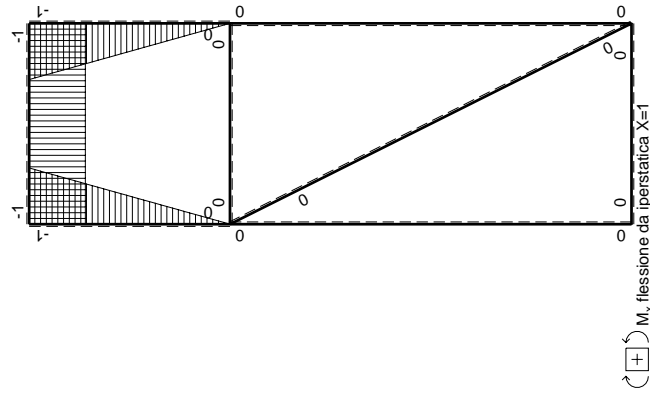
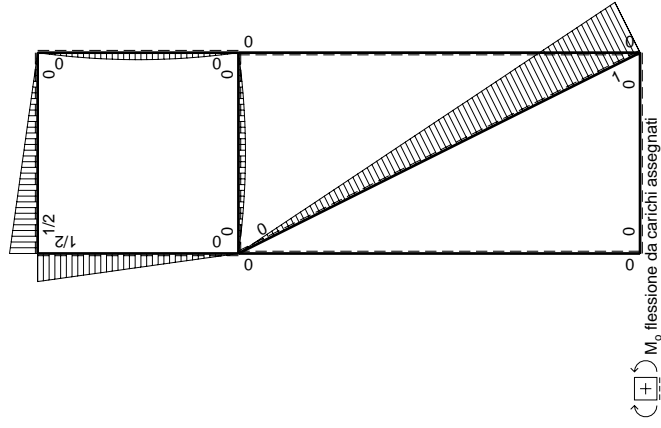
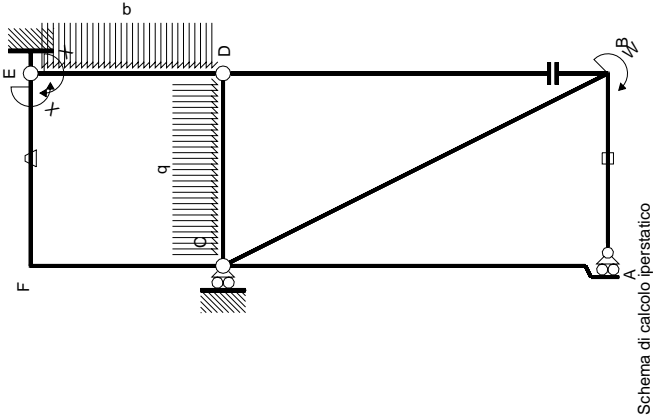

Quadro contributi PLV per iperstatica $X=W_{EF}$

\leftarrow	$M^x(x)$	$M^0(x)$	θ	$M^x M_0$	$M^x \theta$	$M^x M_x$	$\int M^x (M_0/EJ + \theta) dx$	$\int M^x M_x / EJ dx$
AB b	0	0	0	0	0	0	0+0	0
BA b	0	0	0	0	0	0	0	0
BC $\sqrt{5}b$	0	$Fb\sqrt{5}/5Fx$	0	0	0	0	0+0	0
CA 2b	0	0	0	0	0	0	0+0	0
DB 2b	0	0	0	0	0	0	0+0	0
BD 2b	0	0	0	0	0	0	0+0	0
DE b	$-x/b$	$-1/2Fx + 1/2qx^2$	0	$1/2Fx^2/b - 1/2qx^3/b$	0	0	x^2/b^2	$1/3Xb/EJ$
ED b	$1-x/b$	$1/2Fx - 1/2qx^2$	0	$1/2Fx - Fx^2/b + 1/2qx^3/b$	0	0	$1-2x/b+x^2/b^2$	$1/3Xb/EJ$
CD b	0	$1/2Fx - 1/2qx^2$	0	0	0	0	0	0
DC b	0	$-1/2Fx + 1/2qx^2$	0	0	0	0	0+0	0
EF b	-1	$1/2Fx$	$-Fb/EJ$	$-1/2Fx$	Fb/EJ	1	$(-1/4+1)Fb^2/EJ$	Xb/EJ
FE b	1	$-1/2Fb + 1/2Fx$	Fb/EJ	$-1/2Fb + 1/2Fx$	Fb/EJ	1	$(-1/4+1)Fb^2/EJ$	Xb/EJ
FC b	$-1+x/b$	$1/2Fb - 1/2Fx$	0	$-1/2Fb + Fx - 1/2Fx^2/b$	0	0	$1-2x/b+x^2/b^2$	$1/3Xb/EJ$
CF b	x/b	$-1/2Fx$	0	$-1/2Fx^2/b$	0	0	x^2/b^2	$1/3Xb/EJ$
totali								$5/8Fb^2/EJ$
								$-3/8Fb$

Sviluppi di calcolo iperstatica

$$L_{DE}^{xx} = \int_0^b (x^2/b^2) 1/EJ dx = [1/3 x^3/b^2]_0^b 1/EJ$$

$$= (1/3 b) 1/EJ = 1/3 b/EJ$$

$$L_{ED}^{xx} = \int_0^b (1 - 2x/b + x^2/b^2) 1/EJ dx = [x - x^2/b + 1/3 x^3/b^2]_0^b 1/EJ$$

$$= (b - b + 1/3 b) 1/EJ = 1/3 b/EJ$$

$$L_{EF}^{xx} = \int_0^b (1) 1/EJ dx = [x]_0^b 1/EJ$$

$$= (b) 1/EJ = b/EJ$$

$$L_{FE}^{xx} = \int_0^b (1) 1/EJ dx = [x]_0^b 1/EJ$$

$$= (b) 1/EJ = b/EJ$$

$$L_{FC}^{xx} = \int_0^b (1 - 2x/b + x^2/b^2) 1/EJ dx = [x - x^2/b + 1/3 x^3/b^2]_0^b 1/EJ$$

$$= (b - b + 1/3 b) 1/EJ = 1/3 b/EJ$$

$$L_{CF}^{xx} = \int_0^b (x^2/b^2) 1/EJ dx = [1/3 x^3/b^2]_0^b 1/EJ$$

$$= (1/3 b) 1/EJ = 1/3 b/EJ$$

$$L_{DE}^{x_0} = \int_0^b (1/2 x^2/b^2 - 1/2 x^3/b^3) Fb 1/EJ dx = [1/6 x^3/b^2 - 1/8 x^4/b^3]_0^b Fb 1/EJ$$

$$= (1/6 b - 1/8 b) Fb 1/EJ = 1/24 Fb^2/EJ$$

$$L_{ED}^{x_0} = \int_0^b (1/2 x/b - x^2/b^2 + 1/2 x^3/b^3) Fb 1/EJ dx = [1/4 x^2/b - 1/3 x^3/b^2 + 1/8 x^4/b^3]_0^b Fb 1/EJ$$

$$= (1/4 b - 1/3 b + 1/8 b) Fb 1/EJ = 1/24 Fb^2/EJ$$

$$L_{EF}^{x_0} = \int_0^b (-1/2 x/b) Fb 1/EJ dx + \int_0^b (1) \theta dx = [-1/4 x^2/b]_0^b Fb 1/EJ + [x]_0^b \theta$$

$$= (-1/4 b) Fb 1/EJ + (b) \theta = 3/4 Fb^2/EJ$$

$$L_{FE}^{x_0} = \int_0^b (-1/2 + 1/2 x/b) Fb 1/EJ dx + \int_0^b (-1) \theta dx = [-1/2 x + 1/4 x^2/b]_0^b Fb 1/EJ + [-x]_0^b \theta$$

$$= (-1/2 b + 1/4 b) Fb 1/EJ + (-b) \theta = 3/4 Fb^2/EJ$$

$$L_{FC}^{x_0} = \int_0^b (-1/2 + x/b - 1/2 x^2/b^2) Fb 1/EJ dx = [-1/2 x + 1/2 x^2/b - 1/6 x^3/b^2]_0^b Fb 1/EJ$$

$$= (-1/2 b + 1/2 b - 1/6 b) Fb 1/EJ = -1/6 Fb^2/EJ$$

$$L_{CF}^{x_0} = \int_0^b (-1/2 x^2/b^2) Fb 1/EJ dx = [-1/6 x^3/b^2]_0^b Fb 1/EJ$$

$$= (-1/6 b) Fb 1/EJ = -1/6 Fb^2/EJ$$

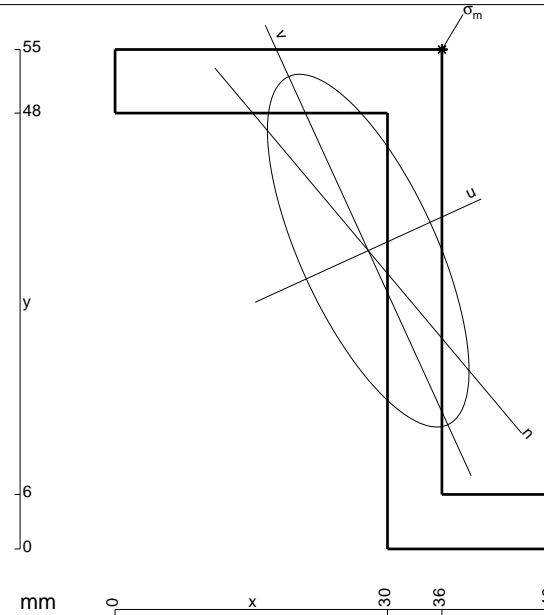

- A = 612. mm²
- J_x = 230903. mm⁴
- J_y = 75448. mm⁴
- J_{xy} = -89831. mm⁴
- J_u = 271965. mm⁴
- J_v = 34385. mm⁴
- α = arctg(2J_{xy}/(J_y-J_x))/2 = .4288
- c = cos α = .9095
- s = sin α = .4157
- x_g = 27.88 mm
- y_g = 32.85 mm
- N = -1127. N
- T_y = -563.5 N
- M_x = 882000. Nmm
- x_m = 36. mm
- y_m = 55. mm
- u_m = 16.59 mm
- v_m = 16.77 mm
- σ_m = N/A - Mc_v/J_u - Ms_u/J_v = -228.2 N/mm²

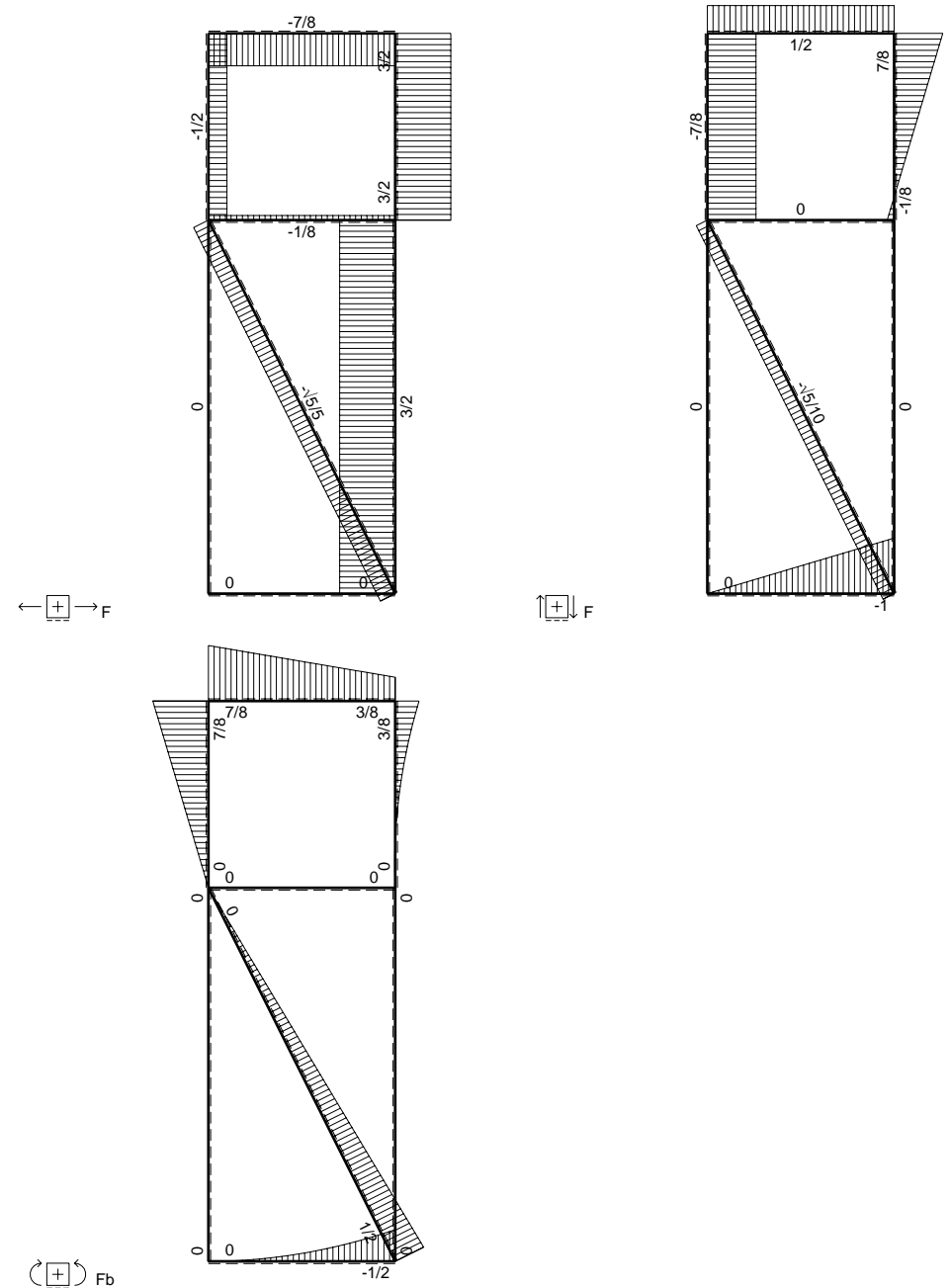
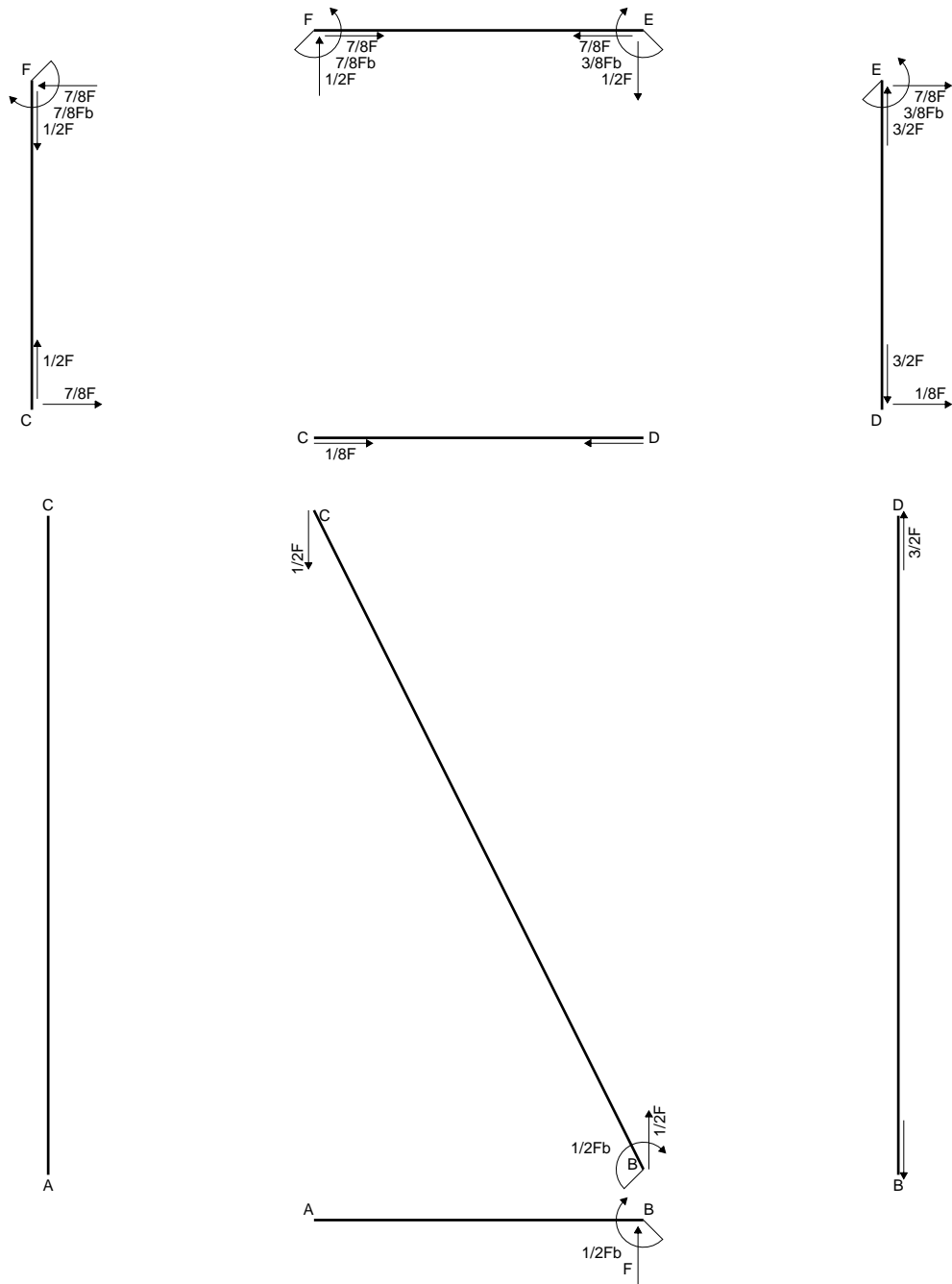

$$L_{DE}^{xx} = \int_0^b (x^2/b^2) 1/EJ dx = [1/3 x^3/b^2]_0^b 1/EJ$$

$$= (1/3 b) 1/EJ = 1/3 b/EJ$$

$$L_{ED}^{xx} = \int_0^b (1 - 2x/b + x^2/b^2) 1/EJ dx = [x - x^2/b + 1/3 x^3/b^2]_0^b 1/EJ$$

$$= (b - b + 1/3 b) 1/EJ = 1/3 b/EJ$$

$$L_{EF}^{xx} = \int_0^b (1) 1/EJ dx = [x]_0^b 1/EJ$$

$$= (b) 1/EJ = b/EJ$$

$$L_{FE}^{xx} = \int_0^b (1) 1/EJ dx = [x]_0^b 1/EJ$$

$$= (b) 1/EJ = b/EJ$$

$$L_{FC}^{xx} = \int_0^b (1 - 2x/b + x^2/b^2) 1/EJ dx = [x - x^2/b + 1/3 x^3/b^2]_0^b 1/EJ$$

$$= (b - b + 1/3 b) 1/EJ = 1/3 b/EJ$$

$$L_{CF}^{xx} = \int_0^b (x^2/b^2) 1/EJ dx = [1/3 x^3/b^2]_0^b 1/EJ$$

$$= (1/3 b) 1/EJ = 1/3 b/EJ$$

$$L_{DE}^{xo} = \int_0^b (1/2 x^2/b^2 - 1/2 x^3/b^3) Fb 1/EJ dx = [1/6 x^3/b^2 - 1/8 x^4/b^3]_0^b Fb 1/EJ$$

$$= (1/6 b - 1/8 b) Fb 1/EJ = 1/24 Fb^2/EJ$$

$$L_{ED}^{xo} = \int_0^b (1/2 x/b - x^2/b^2 + 1/2 x^3/b^3) Fb 1/EJ dx = [1/4 x^2/b - 1/3 x^3/b^2 + 1/8 x^4/b^3]_0^b Fb 1/EJ$$

$$= (1/4 b - 1/3 b + 1/8 b) Fb 1/EJ = 1/24 Fb^2/EJ$$

$$L_{EF}^{xo} = \int_0^b (-1/2 x/b) Fb 1/EJ dx + \int_0^b (1) \theta dx = [-1/4 x^2/b]_0^b Fb 1/EJ + [x]_0^b \theta$$

$$= (-1/4 b) Fb 1/EJ + (b) \theta = 3/4 Fb^2/EJ$$

$$L_{FE}^{xo} = \int_0^b (-1/2 + 1/2 x/b) Fb 1/EJ dx + \int_0^b (-1) \theta dx = [-1/2 x + 1/4 x^2/b]_0^b Fb 1/EJ + [-x]_0^b \theta$$

$$= (-1/2 b + 1/4 b) Fb 1/EJ + (-b) \theta = 3/4 Fb^2/EJ$$

$$L_{FC}^{xo} = \int_0^b (-1/2 + x/b - 1/2 x^2/b^2) Fb 1/EJ dx = [-1/2 x + 1/2 x^2/b - 1/6 x^3/b^2]_0^b Fb 1/EJ$$

$$= (-1/2 b + 1/2 b - 1/6 b) Fb 1/EJ = -1/6 Fb^2/EJ$$

$$L_{CF}^{xo} = \int_0^b (-1/2 x^2/b^2) Fb 1/EJ dx = [-1/6 x^3/b^2]_0^b Fb 1/EJ$$

$$= (-1/6 b) Fb 1/EJ = -1/6 Fb^2/EJ$$

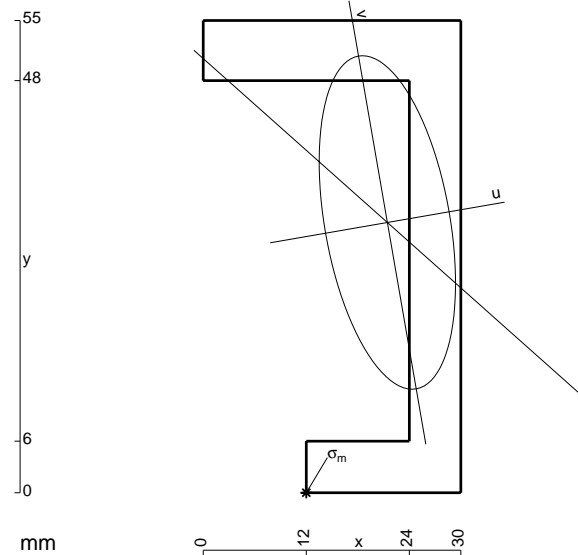

- A = 570. mm²
- J_x = 215051. mm⁴
- J_y = 35943. mm⁴
- J_{xy} = -31999. mm⁴
- J_u = 220596. mm⁴
- J_v = 30398. mm⁴
- α = arctg(2J_{xy}/(J_y-J_x))/2 = .1716
- c = cos α = .9853
- s = sin α = .1707
- x_g = 21.44 mm
- y_g = 31.48 mm
- N = -870. N
- T_y = -1523. N
- M_x = 1126650. Nmm
- x_m = 12. mm
- u_m = -14.68 mm
- v_m = -29.4 mm
- σ_m = N/A - Mcv/J_v - Msu/J_u = 239.3 N/mm²

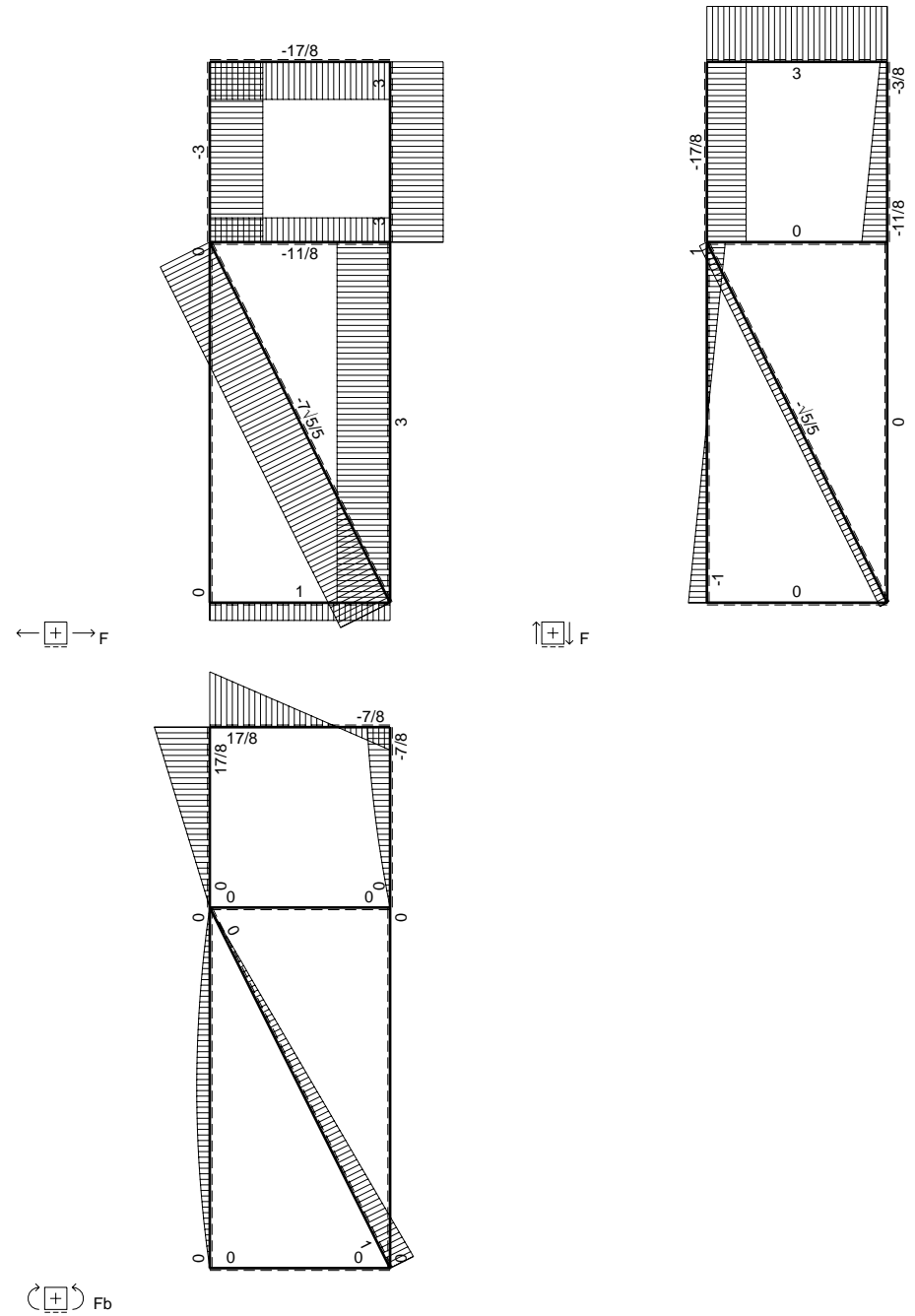
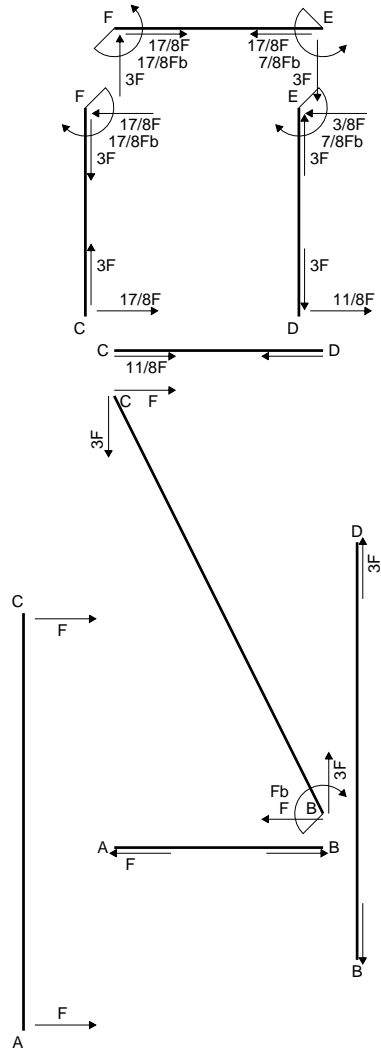

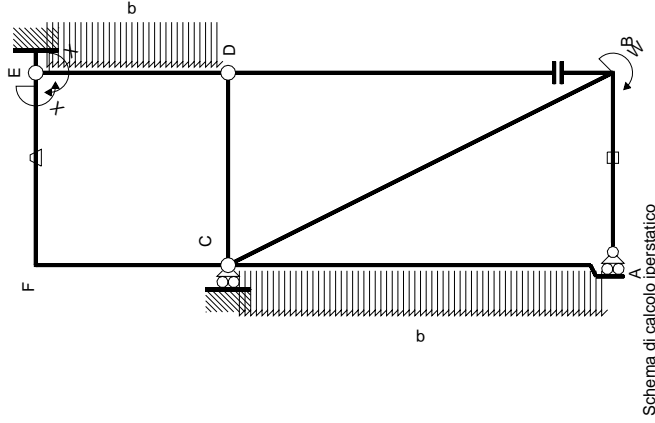

M_0 flessione da carichi assegnati

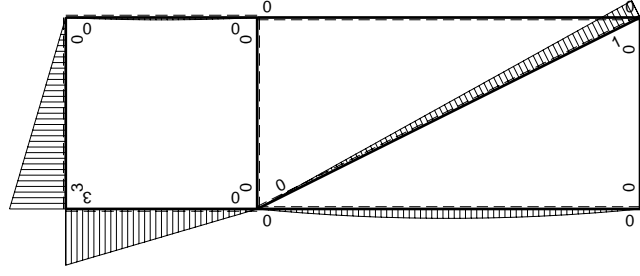

M_x flessione da iperstatica X=1

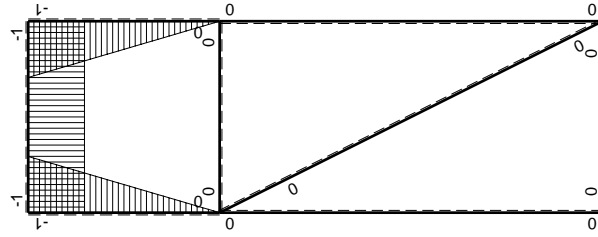

Quadro contributi PLV per iperstatica X=W_{EF}

←	M ⁰ (x)	θ	M ^x M ₀	M ^x θ	M ^x M _x	∫M ^x (M ₀ /EJ+θ)dx	∫M ^x M _x /EJdx
AB b	0	0	0	0	0	0+0	0
BA b	0	0	0	0	0	0	0
BC √5b	0	0	0	0	0	0	0
AC 2b	0	0	0	0	0	0+0	0
CA 2b	0	0	0	0	0	0+0	0
DB 2b	0	0	0	0	0	0+0	0
BD 2b	0	0	0	0	0	0+0	0
DE b	-x/b	0	1/2F ² x ² /b-1/2qx ³ /b	0	x ² /b ²	(1/24+0)F ² /EJ	1/3Xb/EJ
ED b	1-x/b	0	1/2Fx-Fx ² /b+1/2qx ³ /b	0	1-2x/b+x ² /b ²	(1/24+0)F ² /EJ	1/3Xb/EJ
CD b	0	0	0	0	0	0+0	0
DC b	0	0	0	0	0	0+0	0
EF b	-1	-Fb/EJ	-3Fx	-Fb/EJ	1	(-3/2+1)F ² /EJ	Xb/EJ
FE b	1	Fb/EJ	-3Fb+3Fx	Fb/EJ	1	(-3/2+1)F ² /EJ	Xb/EJ
FC b	-1+x/b	0	-3Fb+6Fx-3Fx ² /b	0	1-2x/b+x ² /b ²	(-1+0)F ² /EJ	1/3Xb/EJ
CF b	x/b	0	-3Fx	0	x ² /b ²	(-1+0)F ² /EJ	1/3Xb/EJ
totali						-35/24F ² /EJ	5/3Xb/EJ
						7/8Fb	

iperstatica X=W_{EF}

Sviluppi di calcolo iperstatica

$$L_{DE}^{xx} = \int_0^b (x^2/b^2) 1/EJ dx = [1/3 x^3/b^2]_0^b 1/EJ$$

$$= (1/3 b) 1/EJ = 1/3 b/EJ$$

$$L_{ED}^{xx} = \int_0^b (1 - 2x/b + x^2/b^2) 1/EJ dx = [x - x^2/b + 1/3 x^3/b^2]_0^b 1/EJ$$

$$= (b - b + 1/3 b) 1/EJ = 1/3 b/EJ$$

$$L_{EF}^{xx} = \int_0^b (1) 1/EJ dx = [x]_0^b 1/EJ$$

$$= (b) 1/EJ = b/EJ$$

$$L_{FE}^{xx} = \int_0^b (1) 1/EJ dx = [x]_0^b 1/EJ$$

$$= (b) 1/EJ = b/EJ$$

$$L_{FC}^{xx} = \int_0^b (1 - 2x/b + x^2/b^2) 1/EJ dx = [x - x^2/b + 1/3 x^3/b^2]_0^b 1/EJ$$

$$= (b - b + 1/3 b) 1/EJ = 1/3 b/EJ$$

$$L_{CF}^{xx} = \int_0^b (x^2/b^2) 1/EJ dx = [1/3 x^3/b^2]_0^b 1/EJ$$

$$= (1/3 b) 1/EJ = 1/3 b/EJ$$

$$L_{DE}^{xo} = \int_0^b (1/2 x^2/b^2 - 1/2 x^3/b^3) Fb 1/EJ dx = [1/6 x^3/b^2 - 1/8 x^4/b^3]_0^b Fb 1/EJ$$

$$= (1/6 b - 1/8 b) Fb 1/EJ = 1/24 Fb^2/EJ$$

$$L_{ED}^{xo} = \int_0^b (1/2 x/b - x^2/b^2 + 1/2 x^3/b^3) Fb 1/EJ dx = [1/4 x^2/b - 1/3 x^3/b^2 + 1/8 x^4/b^3]_0^b Fb 1/EJ$$

$$= (1/4 b - 1/3 b + 1/8 b) Fb 1/EJ = 1/24 Fb^2/EJ$$

$$L_{EF}^{xo} = \int_0^b (-3x/b) Fb 1/EJ dx + \int_0^b (1) \theta dx = [-3/2 x^2/b]_0^b Fb 1/EJ + [x]_0^b \theta$$

$$= (-3/2 b) Fb 1/EJ + (b) \theta = -1/2 Fb^2/EJ$$

$$L_{FE}^{xo} = \int_0^b (-3 + 3x/b) Fb 1/EJ dx + \int_0^b (-1) \theta dx = [-3x + 3/2 x^2/b]_0^b Fb 1/EJ + [-x]_0^b \theta$$

$$= (-3b + 3/2 b) Fb 1/EJ + (-b) \theta = -1/2 Fb^2/EJ$$

$$L_{FC}^{xo} = \int_0^b (-3 + 6x/b - 3x^2/b^2) Fb 1/EJ dx = [-3x + 3x^2/b - x^3/b^2]_0^b Fb 1/EJ$$

$$= (-3b + 3b - b) Fb 1/EJ = - Fb^2/EJ$$

$$L_{CF}^{xo} = \int_0^b (-3x^2/b^2) Fb 1/EJ dx = [-x^3/b^2]_0^b Fb 1/EJ$$

$$= (-b) Fb 1/EJ = - Fb^2/EJ$$

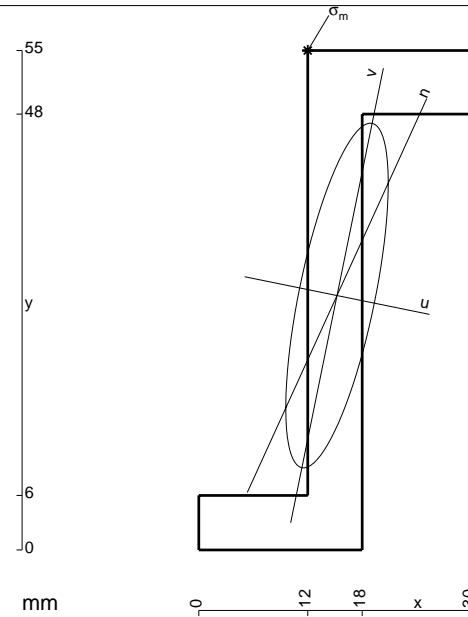

$$A = 486. \text{ mm}^2$$

$$J_x = 175218. \text{ mm}^4$$

$$J_y = 15474. \text{ mm}^4$$

$$J_{xy} = 33964. \text{ mm}^4$$

$$J_u = 182139. \text{ mm}^4$$

$$J_v = 8553. \text{ mm}^4$$

$$\alpha = \text{artg}(2J_{xy}/(J_y - J_x))/2 = -.2010$$

$$c = \cos \alpha = .9799$$

$$s = \sin \alpha = -.1997$$

$$x_g = 15.22 \text{ mm}$$

$$y_g = 28.02 \text{ mm}$$

$$N = -2070. \text{ N}$$

$$T_y = -1466. \text{ N}$$

$$M_x = 571838. \text{ Nmm}$$

$$x_m = 12. \text{ mm}$$

$$y_m = 55. \text{ mm}$$

$$u_m = -8.545 \text{ mm}$$

$$v_m = 25.79 \text{ mm}$$

$$\sigma_m = N/A - Mcv/J_u - Msu/J_v = -197.7 \text{ N/mm}^2$$

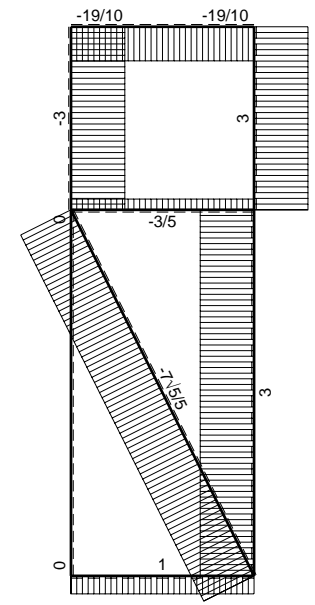
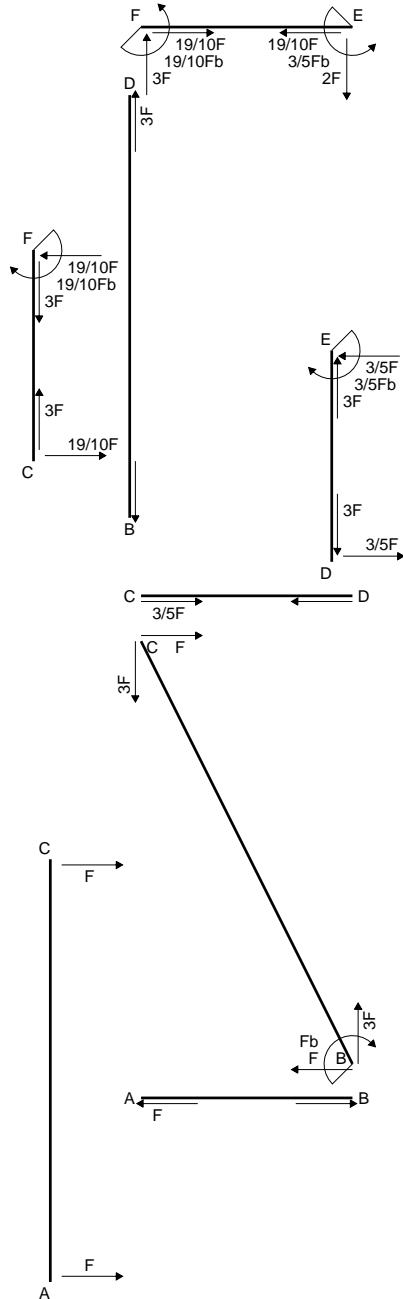

← ⊕ → F

↑ ⊕ ↓ F

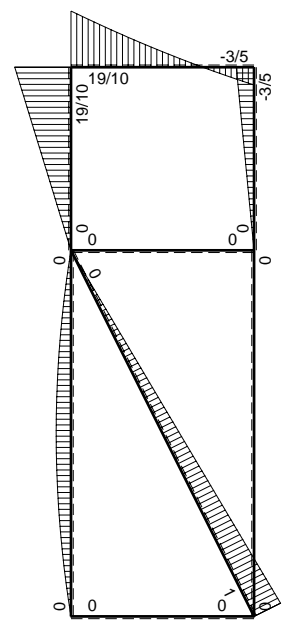

⊕ ⊖ Fb

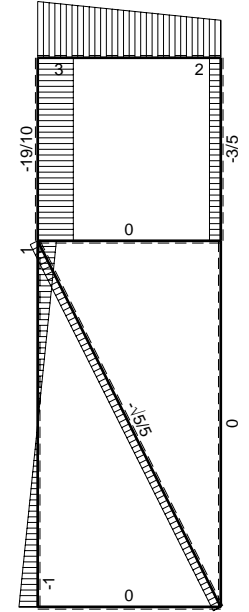

$$L_{DE}^{xx} = \int_0^b (x^2/b^2) 1/EJ dx = [1/3 x^3/b^2]_0^b 1/EJ$$

$$= (1/3 b) 1/EJ = 1/3 b/EJ$$

$$L_{ED}^{xx} = \int_0^b (1 - 2x/b + x^2/b^2) 1/EJ dx = [x - x^2/b + 1/3 x^3/b^2]_0^b 1/EJ$$

$$= (b - b + 1/3 b) 1/EJ = 1/3 b/EJ$$

$$L_{EF}^{xx} = \int_0^b (1) 1/EJ dx = [x]_0^b 1/EJ$$

$$= (b) 1/EJ = b/EJ$$

$$L_{FE}^{xx} = \int_0^b (1) 1/EJ dx = [x]_0^b 1/EJ$$

$$= (b) 1/EJ = b/EJ$$

$$L_{FC}^{xx} = \int_0^b (1 - 2x/b + x^2/b^2) 1/EJ dx = [x - x^2/b + 1/3 x^3/b^2]_0^b 1/EJ$$

$$= (b - b + 1/3 b) 1/EJ = 1/3 b/EJ$$

$$L_{CF}^{xx} = \int_0^b (x^2/b^2) 1/EJ dx = [1/3 x^3/b^2]_0^b 1/EJ$$

$$= (1/3 b) 1/EJ = 1/3 b/EJ$$

$$L_{EF}^{xo} = \int_0^b (-2x/b - 1/2 x^2/b^2) Fb 1/EJ dx + \int_0^b (1) \theta dx = [-x^2/b - 1/6 x^3/b^2]_0^b Fb 1/EJ + [x]_0^b \theta$$

$$= (-b - 1/6 b) Fb 1/EJ + (b) \theta = -1/6 Fb^2/EJ$$

$$L_{FE}^{xo} = \int_0^b (-5/2 + 3x/b - 1/2 x^2/b^2) Fb 1/EJ dx + \int_0^b (-1) \theta dx$$

$$= [-5/2 x + 3/2 x^2/b - 1/6 x^3/b^2]_0^b Fb 1/EJ + [-x]_0^b \theta$$

$$= (-5/2 b + 3/2 b - 1/6 b) Fb 1/EJ + (-b) \theta = -1/6 Fb^2/EJ$$

$$L_{FC}^{xo} = \int_0^b (-5/2 + 5x/b - 5/2 x^2/b^2) Fb 1/EJ dx = [-5/2 x + 5/2 x^2/b - 5/6 x^3/b^2]_0^b Fb 1/EJ$$

$$= (-5/2 b + 5/2 b - 5/6 b) Fb 1/EJ = -5/6 Fb^2/EJ$$

$$L_{CF}^{xo} = \int_0^b (-5/2 x^2/b^2) Fb 1/EJ dx = [-5/6 x^3/b^2]_0^b Fb 1/EJ$$

$$= (-5/6 b) Fb 1/EJ = -5/6 Fb^2/EJ$$

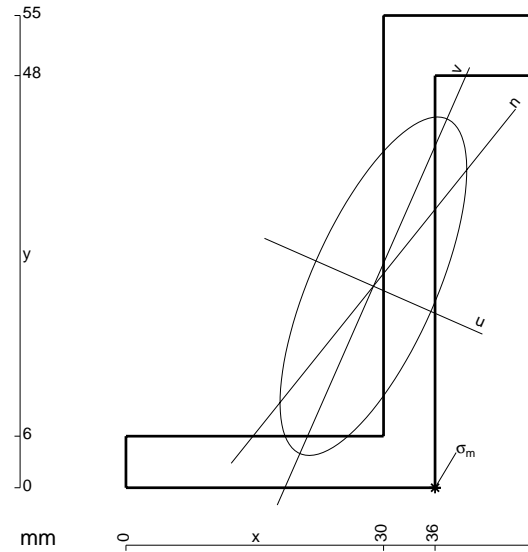

- A = 594. mm²
- J_x = 230851. mm⁴
- J_y = 70234. mm⁴
- J_{xy} = 87513. mm⁴
- J_u = 269319. mm⁴
- J_v = 31766. mm⁴
- α = arctg(2J_{xy}/(J_y-J_x))/2 = -.4142
- c = cos α = .9155
- s = sin α = -.4024
- x_g = 28.82 mm
- y_g = 23.47 mm
- N = -1900. N
- T_y = 3000. N
- M_x = 798000. Nmm
- x_m = 36. mm
- u_m = 16.02 mm
- v_m = -18.6 mm
- σ_m = N/A - Mcv/J_u - Msu/J_v = 209.2 N/mm²

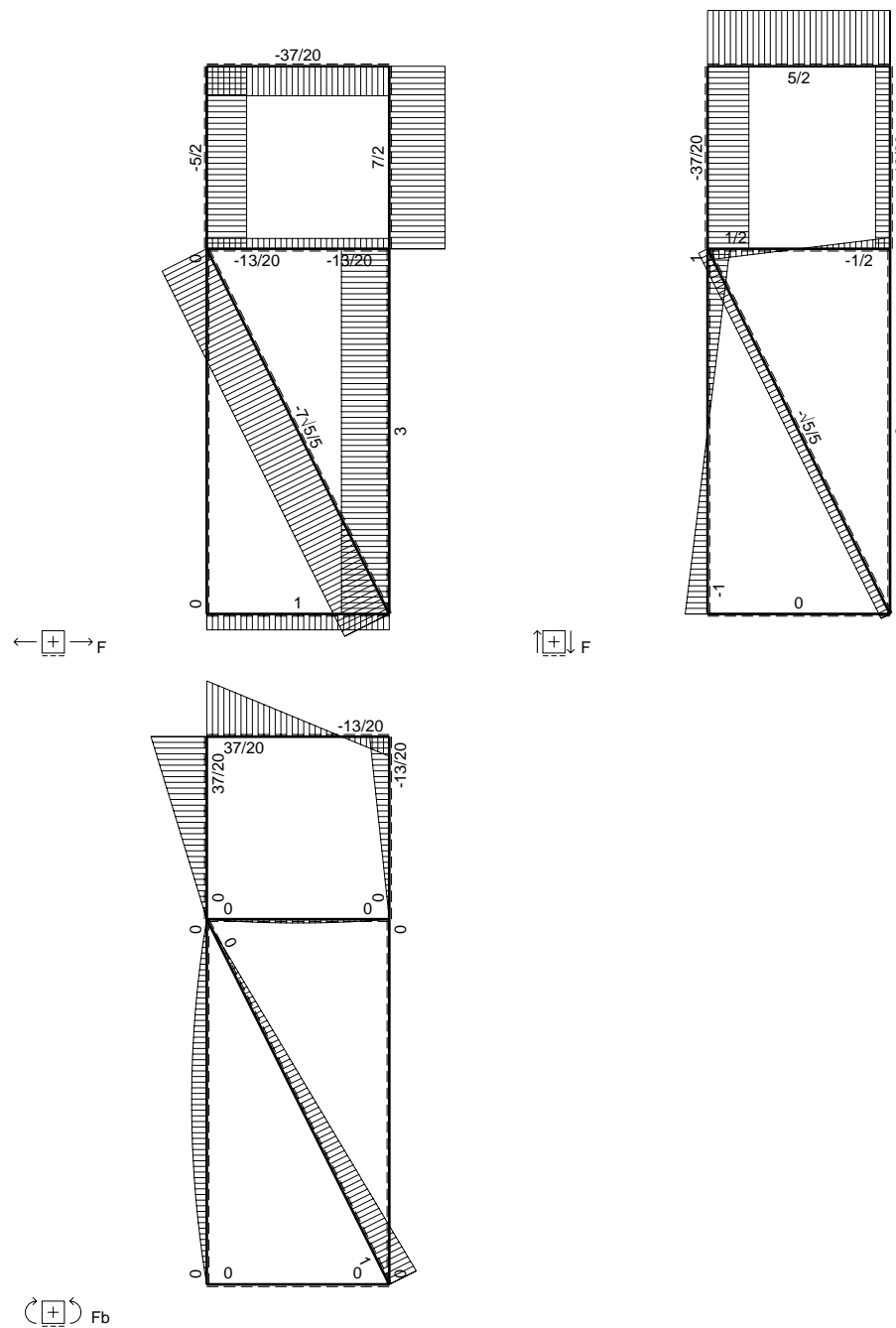
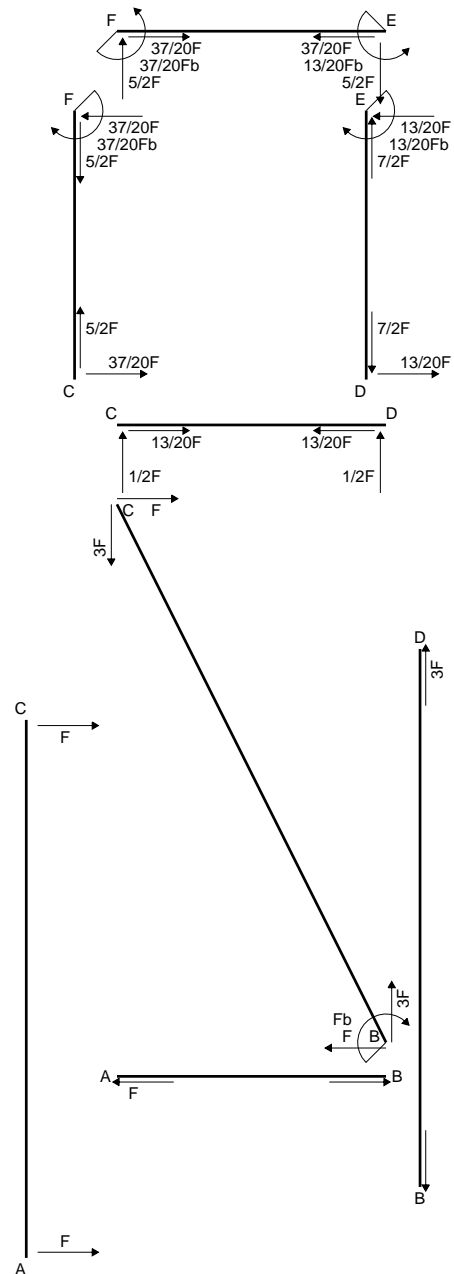

$$L_{DE}^{xx} = \int_0^b (x^2/b^2) 1/EJ dx = [1/3 x^3/b^2]_0^b 1/EJ$$

$$= (1/3 b) 1/EJ = 1/3 b/EJ$$

$$L_{ED}^{xx} = \int_0^b (1 - 2x/b + x^2/b^2) 1/EJ dx = [x - x^2/b + 1/3 x^3/b^2]_0^b 1/EJ$$

$$= (b - b + 1/3 b) 1/EJ = 1/3 b/EJ$$

$$L_{EF}^{xx} = \int_0^b (1) 1/EJ dx = [x]_0^b 1/EJ$$

$$= (b) 1/EJ = b/EJ$$

$$L_{FE}^{xx} = \int_0^b (1) 1/EJ dx = [x]_0^b 1/EJ$$

$$= (b) 1/EJ = b/EJ$$

$$L_{FC}^{xx} = \int_0^b (1 - 2x/b + x^2/b^2) 1/EJ dx = [x - x^2/b + 1/3 x^3/b^2]_0^b 1/EJ$$

$$= (b - b + 1/3 b) 1/EJ = 1/3 b/EJ$$

$$L_{CF}^{xx} = \int_0^b (x^2/b^2) 1/EJ dx = [1/3 x^3/b^2]_0^b 1/EJ$$

$$= (1/3 b) 1/EJ = 1/3 b/EJ$$

$$L_{EF}^{xo} = \int_0^b (-5/2 x/b) Fb 1/EJ dx + \int_0^b (1) \theta dx = [-5/4 x^2/b]_0^b Fb 1/EJ + [x]_0^b \theta$$

$$= (-5/4 b) Fb 1/EJ + (b) \theta = -1/4 Fb^2/EJ$$

$$L_{FE}^{xo} = \int_0^b (-5/2 + 5/2 x/b) Fb 1/EJ dx + \int_0^b (-1) \theta dx = [-5/2 x + 5/4 x^2/b]_0^b Fb 1/EJ + [-x]_0^b \theta$$

$$= (-5/2 b + 5/4 b) Fb 1/EJ + (-b) \theta = -1/4 Fb^2/EJ$$

$$L_{FC}^{xo} = \int_0^b (-5/2 + 5x/b - 5/2 x^2/b^2) Fb 1/EJ dx = [-5/2 x + 5/2 x^2/b - 5/6 x^3/b^2]_0^b Fb 1/EJ$$

$$= (-5/2 b + 5/2 b - 5/6 b) Fb 1/EJ = -5/6 Fb^2/EJ$$

$$L_{CF}^{xo} = \int_0^b (-5/2 x^2/b^2) Fb 1/EJ dx = [-5/6 x^3/b^2]_0^b Fb 1/EJ$$

$$= (-5/6 b) Fb 1/EJ = -5/6 Fb^2/EJ$$

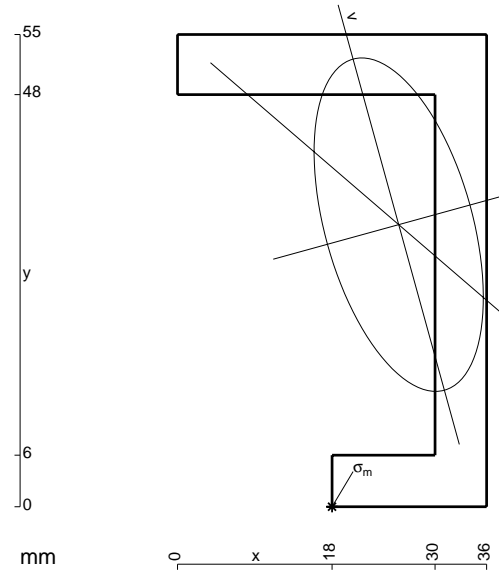

- A = 612. mm²
- J_x = 230903. mm⁴
- J_y = 59438. mm⁴
- J_{xy} = -51141. mm⁴
- J_u = 244998. mm⁴
- J_v = 45343. mm⁴
- α = artg(2J_{xy}/(J_y-J_x))/2 = .2689
- c = cosα = .9641
- s = sinα = .2657
- x_g = 25.76 mm
- y_g = 32.85 mm
- N = -2294. N
- T_y = 3100. N
- M_x = 1055240. Nmm
- x_m = 18. mm
- u_m = -16.21 mm
- v_m = -29.61 mm
- σ_m = N/A - Mcv/J_u - Msu/J_v = 219.5 N/mm²

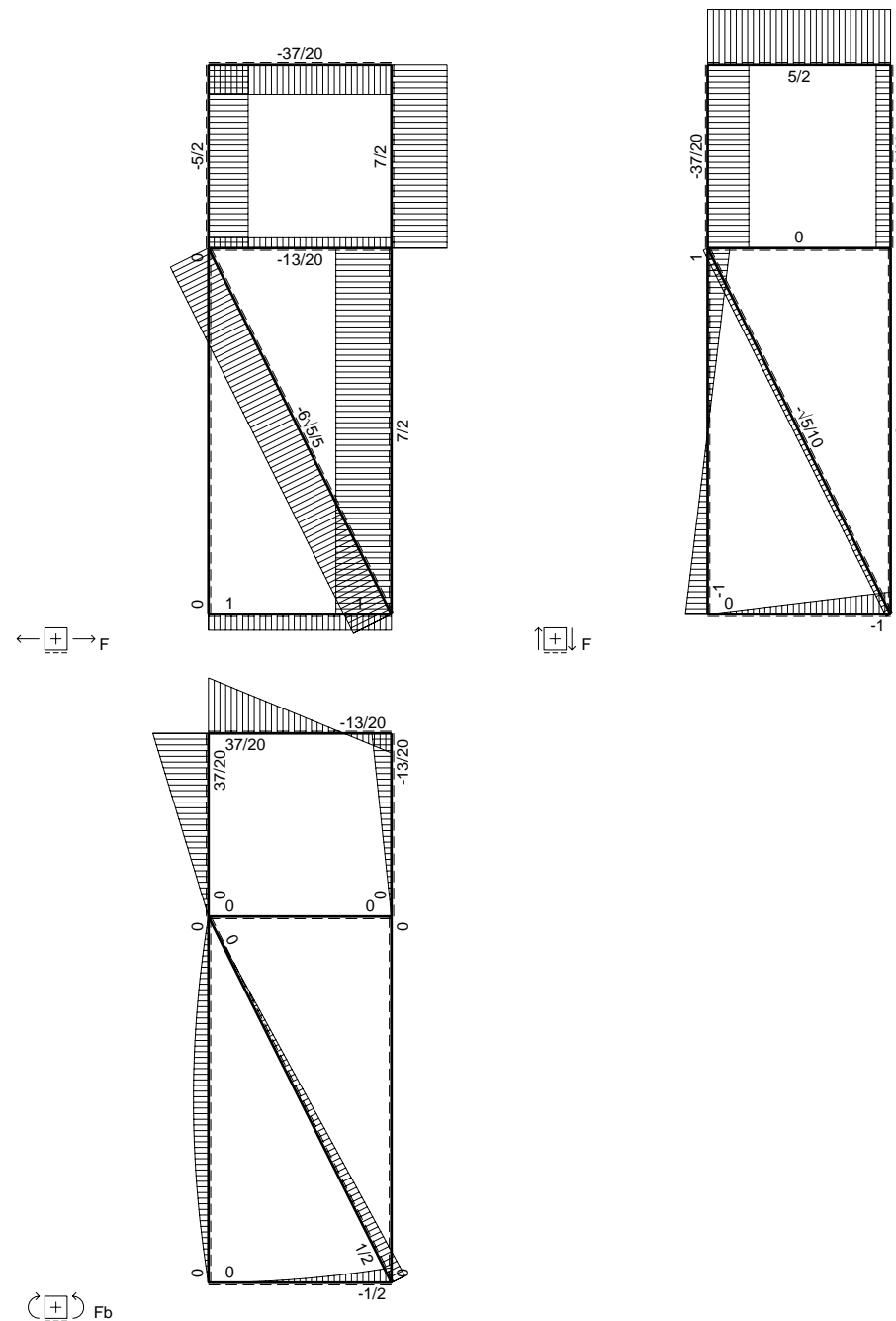
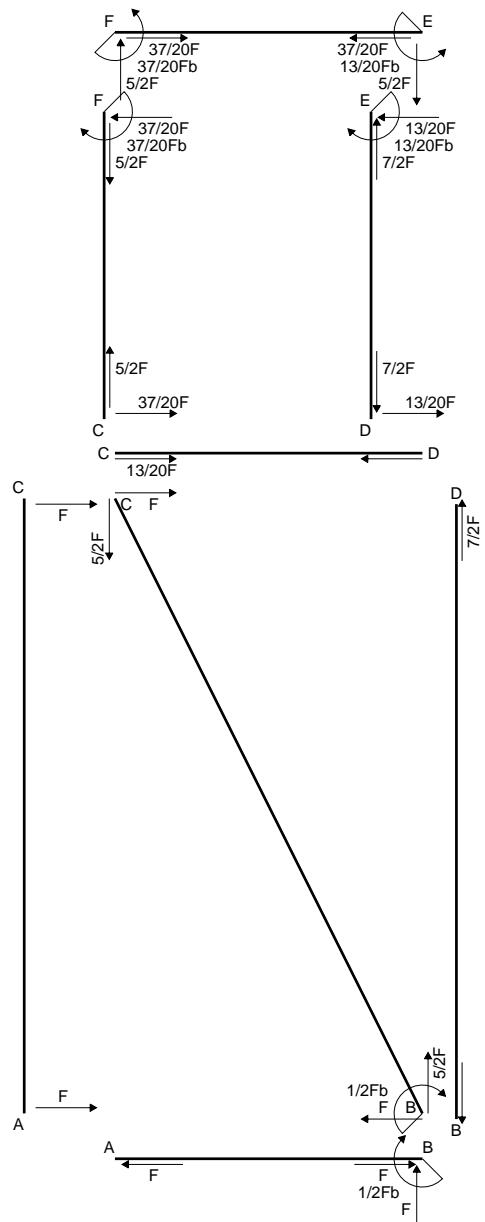

$$L_{DE}^{xx} = \int_0^b (x^2/b^2) 1/EJ dx = [1/3 x^3/b^2]_0^b 1/EJ$$

$$= (1/3 b) 1/EJ = 1/3 b/EJ$$

$$L_{ED}^{xx} = \int_0^b (1 - 2x/b + x^2/b^2) 1/EJ dx = [x - x^2/b + 1/3 x^3/b^2]_0^b 1/EJ$$

$$= (b - b + 1/3 b) 1/EJ = 1/3 b/EJ$$

$$L_{EF}^{xx} = \int_0^b (1) 1/EJ dx = [x]_0^b 1/EJ$$

$$= (b) 1/EJ = b/EJ$$

$$L_{FE}^{xx} = \int_0^b (1) 1/EJ dx = [x]_0^b 1/EJ$$

$$= (b) 1/EJ = b/EJ$$

$$L_{FC}^{xx} = \int_0^b (1 - 2x/b + x^2/b^2) 1/EJ dx = [x - x^2/b + 1/3 x^3/b^2]_0^b 1/EJ$$

$$= (b - b + 1/3 b) 1/EJ = 1/3 b/EJ$$

$$L_{CF}^{xx} = \int_0^b (x^2/b^2) 1/EJ dx = [1/3 x^3/b^2]_0^b 1/EJ$$

$$= (1/3 b) 1/EJ = 1/3 b/EJ$$

$$L_{EF}^{xo} = \int_0^b (-5/2 x/b) Fb 1/EJ dx + \int_0^b (1) \theta dx = [-5/4 x^2/b]_0^b Fb 1/EJ + [x]_0^b \theta$$

$$= (-5/4 b) Fb 1/EJ + (b) \theta = -1/4 Fb^2/EJ$$

$$L_{FE}^{xo} = \int_0^b (-5/2 + 5/2 x/b) Fb 1/EJ dx + \int_0^b (-1) \theta dx = [-5/2 x + 5/4 x^2/b]_0^b Fb 1/EJ + [-x]_0^b \theta$$

$$= (-5/2 b + 5/4 b) Fb 1/EJ + (-b) \theta = -1/4 Fb^2/EJ$$

$$L_{FC}^{xo} = \int_0^b (-5/2 + 5x/b - 5/2 x^2/b^2) Fb 1/EJ dx = [-5/2 x + 5/2 x^2/b - 5/6 x^3/b^2]_0^b Fb 1/EJ$$

$$= (-5/2 b + 5/2 b - 5/6 b) Fb 1/EJ = -5/6 Fb^2/EJ$$

$$L_{CF}^{xo} = \int_0^b (-5/2 x^2/b^2) Fb 1/EJ dx = [-5/6 x^3/b^2]_0^b Fb 1/EJ$$

$$= (-5/6 b) Fb 1/EJ = -5/6 Fb^2/EJ$$

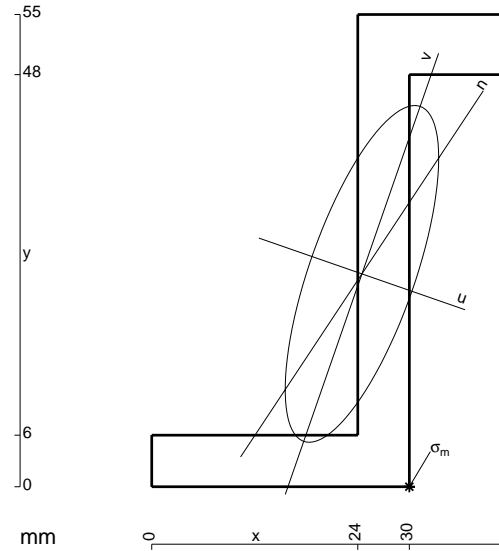

$$A = 558. \text{ mm}^2$$

$$J_x = 214685. \text{ mm}^4$$

$$J_y = 44581. \text{ mm}^4$$

$$J_{xy} = 67260. \text{ mm}^4$$

$$J_u = 238066. \text{ mm}^4$$

$$J_v = 21200. \text{ mm}^4$$

$$\alpha = \text{artg}(2J_{xy}/(J_y - J_x))/2 = -.3346$$

$$c = \cos \alpha = .9446$$

$$s = \sin \alpha = -.3283$$

$$x_g = 24.48 \text{ mm}$$

$$y_g = 24.79 \text{ mm}$$

$$N = -1591. \text{ N}$$

$$T_y = 2150. \text{ N}$$

$$M_x = 795500. \text{ Nmm}$$

$$x_m = 30. \text{ mm}$$

$$u_m = 13.35 \text{ mm}$$

$$v_m = -21.6 \text{ mm}$$

$$\sigma_m = N/A - Mcv/J_u - Msu/J_v = 229.8 \text{ N/mm}^2$$

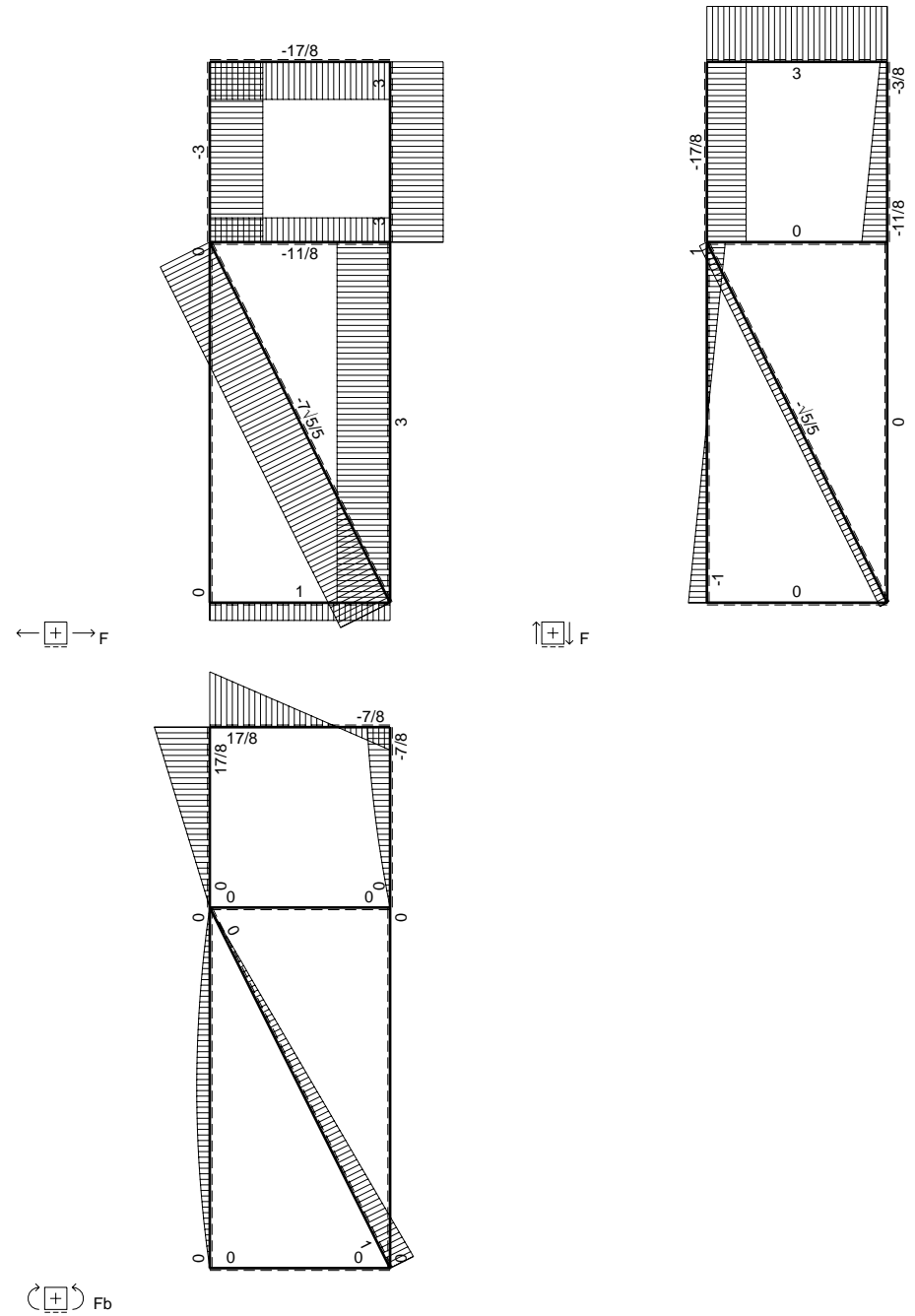
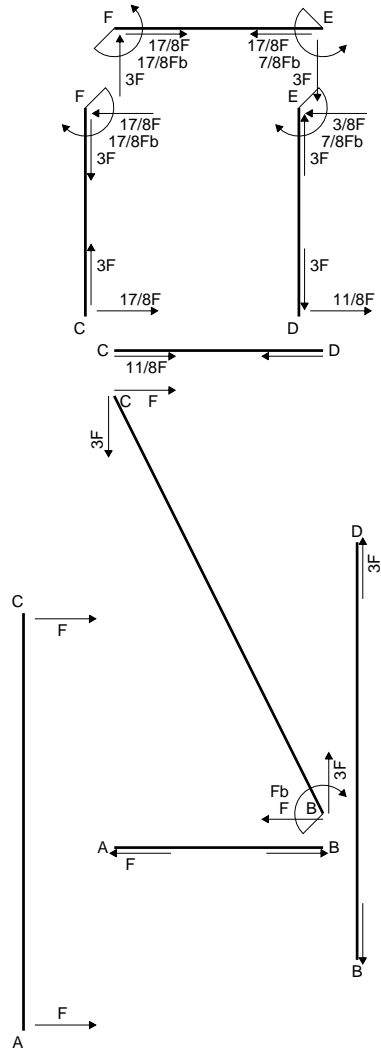

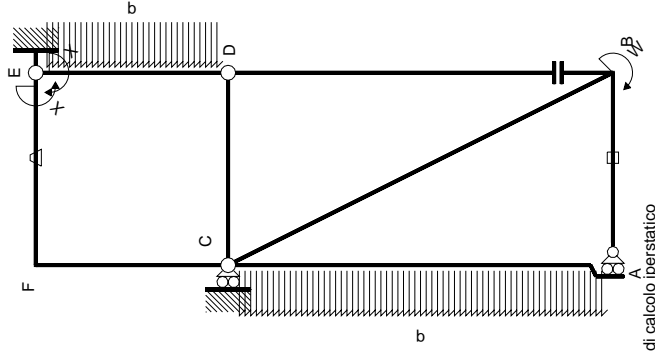

M_0 flessione da carichi assegnati

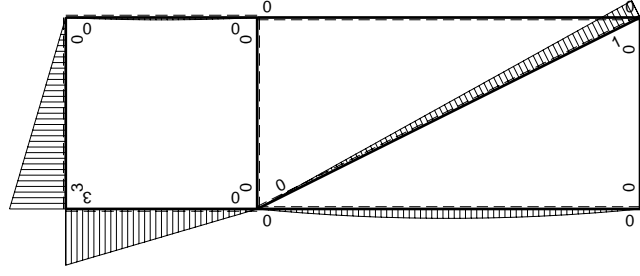

Quadro contributi PLV per iperstatica $X=W_{EF}$

\leftarrow	$M^x(x)$	$M^0(x)$	θ	$M^x M_0$	$M^x \theta$	$M^x M_x$	$\int M^x (M_0/EJ + \theta) dx$	$\int M^x M_x / EJ dx$
AB b	0	0	0	0	0	0	0+0	0
BA b	0	0	0	0	0	0	0	0
BC $\sqrt{5}b$	0	$Fb - \sqrt{5}/5Fx$	0	0	0	0	0	0
AC 2b	0	$-Fx + 1/2qx^2$	0	0	0	0	0+0	0
CA 2b	0	$Fx - 1/2qx^2$	0	0	0	0	0	0
DB 2b	0	0	0	0	0	0	0+0	0
BD 2b	0	0	0	0	0	0	0	0
DE b	$-x/b$	$-1/2Fx + 1/2qx^2$	0	$1/2Fx^2/b - 1/2qx^3/b$	0	0	x^2/b^2	$1/3xb/EJ$
ED b	$1-x/b$	$1/2Fx - 1/2qx^2$	0	$1/2Fx - Fx^2/b + 1/2qx^3/b$	0	0	$1-2x/b+x^2/b^2$	$1/3xb/EJ$
CD b	0	0	0	0	0	0	0+0	0
DC b	0	0	0	0	0	0	0	0
EF b	-1	$3Fx$	$-Fb/EJ$	$-3Fx$	Fb/EJ	1	$(-3/2+1)Fb^2/EJ$	Xb/EJ
FE b	1	$-3Fb+3Fx$	Fb/EJ	$-3Fb+3Fx$	Fb/EJ	1	$(-3/2+1)Fb^2/EJ$	Xb/EJ
FC b	$-1+x/b$	$3Fb-3Fx$	0	$-3Fb+6Fx-3Fx^2/b$	0	0	$1-2x/b+x^2/b^2$	$(-1+0)Fb^2/EJ$
CF b	x/b	$-3Fx$	0	$-3Fx^2/b$	0	0	x^2/b^2	$1/3xb/EJ$
totali								$5/3xb/EJ$
								$7/8Fb$

Sviluppi di calcolo iperstatica

M_x flessione da iperstatica $X=1$

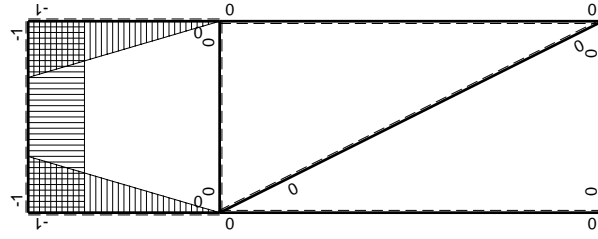

$$L_{DE}^{xx} = \int_0^b (x^2/b^2) 1/EJ dx = [1/3 x^3/b^2]_0^b 1/EJ$$

$$= (1/3 b) 1/EJ = 1/3 b/EJ$$

$$L_{ED}^{xx} = \int_0^b (1 - 2x/b + x^2/b^2) 1/EJ dx = [x - x^2/b + 1/3 x^3/b^2]_0^b 1/EJ$$

$$= (b - b + 1/3 b) 1/EJ = 1/3 b/EJ$$

$$L_{EF}^{xx} = \int_0^b (1) 1/EJ dx = [x]_0^b 1/EJ$$

$$= (b) 1/EJ = b/EJ$$

$$L_{FE}^{xx} = \int_0^b (1) 1/EJ dx = [x]_0^b 1/EJ$$

$$= (b) 1/EJ = b/EJ$$

$$L_{FC}^{xx} = \int_0^b (1 - 2x/b + x^2/b^2) 1/EJ dx = [x - x^2/b + 1/3 x^3/b^2]_0^b 1/EJ$$

$$= (b - b + 1/3 b) 1/EJ = 1/3 b/EJ$$

$$L_{CF}^{xx} = \int_0^b (x^2/b^2) 1/EJ dx = [1/3 x^3/b^2]_0^b 1/EJ$$

$$= (1/3 b) 1/EJ = 1/3 b/EJ$$

$$L_{DE}^{xo} = \int_0^b (1/2 x^2/b^2 - 1/2 x^3/b^3) Fb 1/EJ dx = [1/6 x^3/b^2 - 1/8 x^4/b^3]_0^b Fb 1/EJ$$

$$= (1/6 b - 1/8 b) Fb 1/EJ = 1/24 Fb^2/EJ$$

$$L_{ED}^{xo} = \int_0^b (1/2 x/b - x^2/b^2 + 1/2 x^3/b^3) Fb 1/EJ dx = [1/4 x^2/b - 1/3 x^3/b^2 + 1/8 x^4/b^3]_0^b Fb 1/EJ$$

$$= (1/4 b - 1/3 b + 1/8 b) Fb 1/EJ = 1/24 Fb^2/EJ$$

$$L_{EF}^{xo} = \int_0^b (-3x/b) Fb 1/EJ dx + \int_0^b (1) \theta dx = [-3/2 x^2/b]_0^b Fb 1/EJ + [x]_0^b \theta$$

$$= (-3/2 b) Fb 1/EJ + (b) \theta = -1/2 Fb^2/EJ$$

$$L_{FE}^{xo} = \int_0^b (-3 + 3x/b) Fb 1/EJ dx + \int_0^b (-1) \theta dx = [-3x + 3/2 x^2/b]_0^b Fb 1/EJ + [-x]_0^b \theta$$

$$= (-3b + 3/2 b) Fb 1/EJ + (-b) \theta = -1/2 Fb^2/EJ$$

$$L_{FC}^{xo} = \int_0^b (-3 + 6x/b - 3x^2/b^2) Fb 1/EJ dx = [-3x + 3x^2/b - x^3/b^2]_0^b Fb 1/EJ$$

$$= (-3b + 3b - b) Fb 1/EJ = -Fb^2/EJ$$

$$L_{CF}^{xo} = \int_0^b (-3x^2/b^2) Fb 1/EJ dx = [-x^3/b^2]_0^b Fb 1/EJ$$

$$= (-b) Fb 1/EJ = -Fb^2/EJ$$

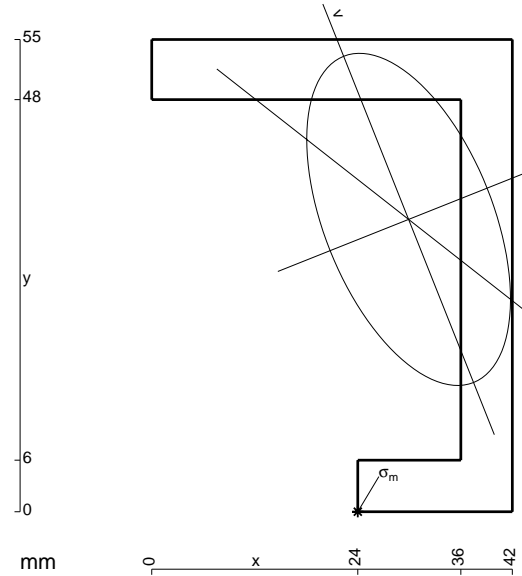

- A = 654. mm²
- J_x = 244740. mm⁴
- J_y = 92084. mm⁴
- J_{xy} = -72222. mm⁴
- J_u = 273493. mm⁴
- J_v = 63331. mm⁴
- α = arctg(2J_{xy}/(J_y-J_x))/2 = .3789
- c = cos α = .9291
- s = sin α = .3699
- x_g = 29.92 mm
- y_g = 34.05 mm
- N = -2189. N
- T_y = 3090. N
- M_x = 1181930. Nmm
- x_m = 24. mm
- u_m = -18.09 mm
- v_m = -29.45 mm
- σ_m = N/A - Mcv/J_u - Msu/J_v = 239.8 N/mm²

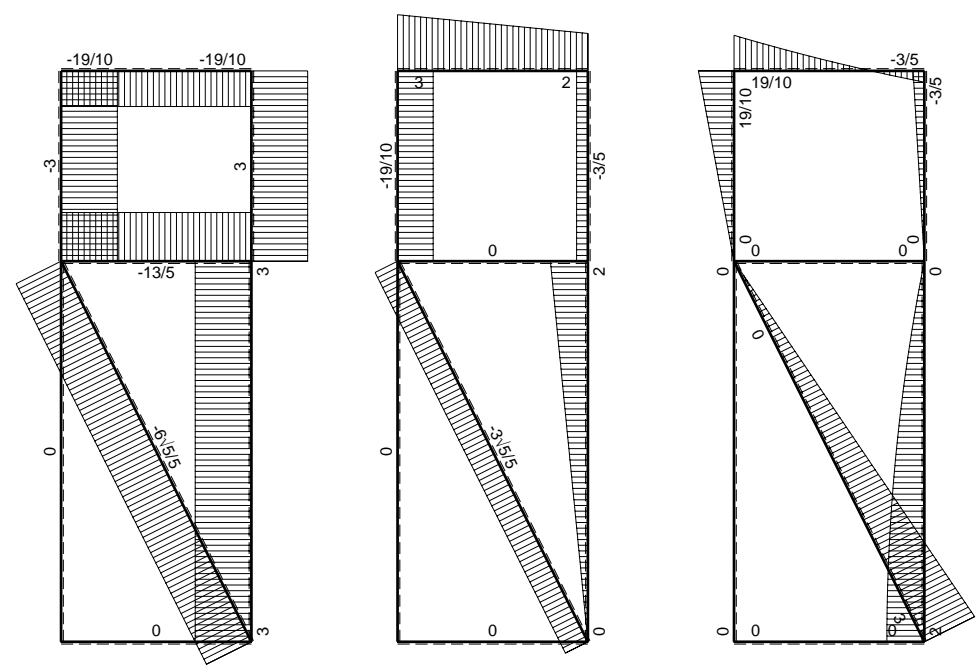
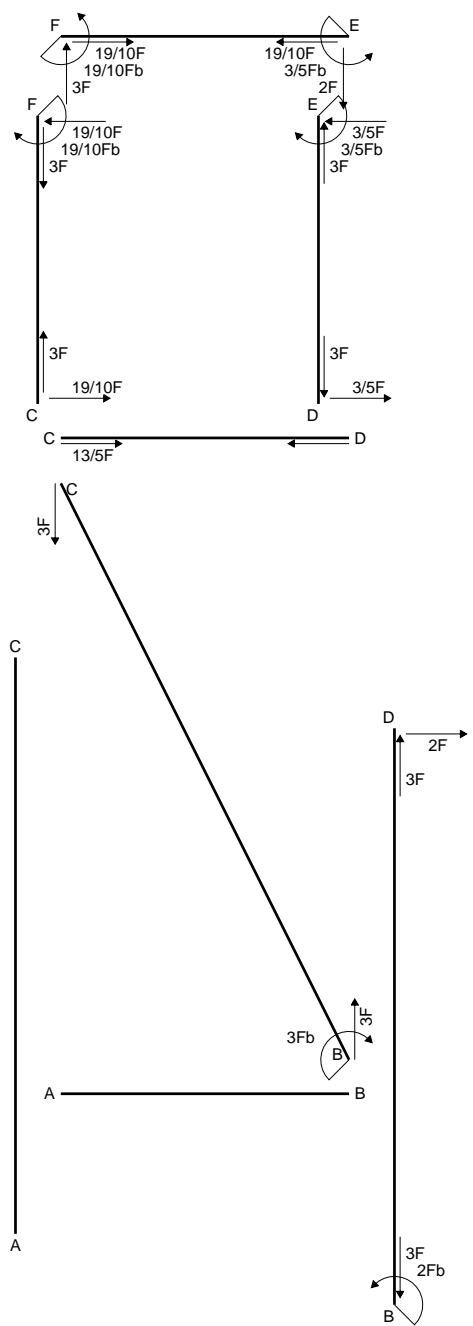

← ⊕ → F

↑ ⊕ ↓ F

⊕ ⊖ F_b

$$L_{DE}^{xx} = \int_0^b (x^2/b^2) 1/EJ dx = [1/3 x^3/b^2]_0^b 1/EJ$$

$$= (1/3 b) 1/EJ = 1/3 b/EJ$$

$$L_{ED}^{xx} = \int_0^b (1 - 2x/b + x^2/b^2) 1/EJ dx = [x - x^2/b + 1/3 x^3/b^2]_0^b 1/EJ$$

$$= (b - b + 1/3 b) 1/EJ = 1/3 b/EJ$$

$$L_{EF}^{xx} = \int_0^b (1) 1/EJ dx = [x]_0^b 1/EJ$$

$$= (b) 1/EJ = b/EJ$$

$$L_{FE}^{xx} = \int_0^b (1) 1/EJ dx = [x]_0^b 1/EJ$$

$$= (b) 1/EJ = b/EJ$$

$$L_{FC}^{xx} = \int_0^b (1 - 2x/b + x^2/b^2) 1/EJ dx = [x - x^2/b + 1/3 x^3/b^2]_0^b 1/EJ$$

$$= (b - b + 1/3 b) 1/EJ = 1/3 b/EJ$$

$$L_{CF}^{xx} = \int_0^b (x^2/b^2) 1/EJ dx = [1/3 x^3/b^2]_0^b 1/EJ$$

$$= (1/3 b) 1/EJ = 1/3 b/EJ$$

$$L_{EF}^{x\theta} = \int_0^b (-2x/b - 1/2 x^2/b^2) Fb 1/EJ dx + \int_0^b (1) \theta dx = [-x^2/b - 1/6 x^3/b^2]_0^b Fb 1/EJ + [x]_0^b \theta$$

$$= (-b - 1/6 b) Fb 1/EJ + (b) \theta = -1/6 Fb^2/EJ$$

$$L_{FE}^{x\theta} = \int_0^b (-5/2 + 3x/b - 1/2 x^2/b^2) Fb 1/EJ dx + \int_0^b (-1) \theta dx$$

$$= [-5/2 x + 3/2 x^2/b - 1/6 x^3/b^2]_0^b Fb 1/EJ + [-x]_0^b \theta$$

$$= (-5/2 b + 3/2 b - 1/6 b) Fb 1/EJ + (-b) \theta = -1/6 Fb^2/EJ$$

$$L_{FC}^{x\theta} = \int_0^b (-5/2 + 5x/b - 5/2 x^2/b^2) Fb 1/EJ dx = [-5/2 x + 5/2 x^2/b - 5/6 x^3/b^2]_0^b Fb 1/EJ$$

$$= (-5/2 b + 5/2 b - 5/6 b) Fb 1/EJ = -5/6 Fb^2/EJ$$

$$L_{CF}^{x\theta} = \int_0^b (-5/2 x^2/b^2) Fb 1/EJ dx = [-5/6 x^3/b^2]_0^b Fb 1/EJ$$

$$= (-5/6 b) Fb 1/EJ = -5/6 Fb^2/EJ$$

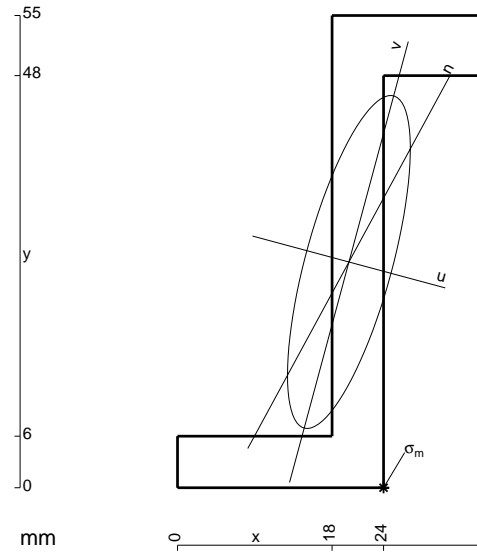

$$A = 522. \text{ mm}^2$$

$$J_x = 196305. \text{ mm}^4$$

$$J_y = 26711. \text{ mm}^4$$

$$J_{xy} = 49244. \text{ mm}^4$$

$$J_u = 209567. \text{ mm}^4$$

$$J_v = 13450. \text{ mm}^4$$

$$\alpha = \text{artg}(2J_{xy}/(J_y - J_x))/2 = -.2631$$

$$c = \cos \alpha = .9656$$

$$s = \sin \alpha = -.2600$$

$$x_g = 19.97 \text{ mm}$$

$$y_g = 26.29 \text{ mm}$$

$$N = -966. \text{ N}$$

$$T_y = -483. \text{ N}$$

$$M_x = 626400. \text{ Nmm}$$

$$x_m = 24. \text{ mm}$$

$$u_m = 10.73 \text{ mm}$$

$$v_m = -24.34 \text{ mm}$$

$$\sigma_m = N/A - Mcv/J_u - Msu/J_v = 198.4 \text{ N/mm}^2$$

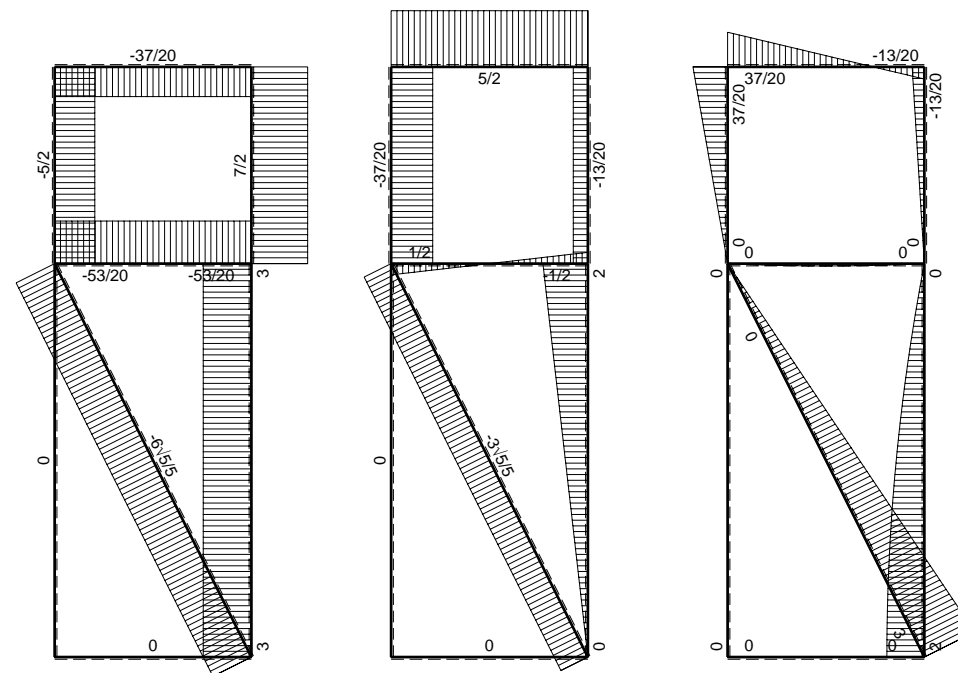
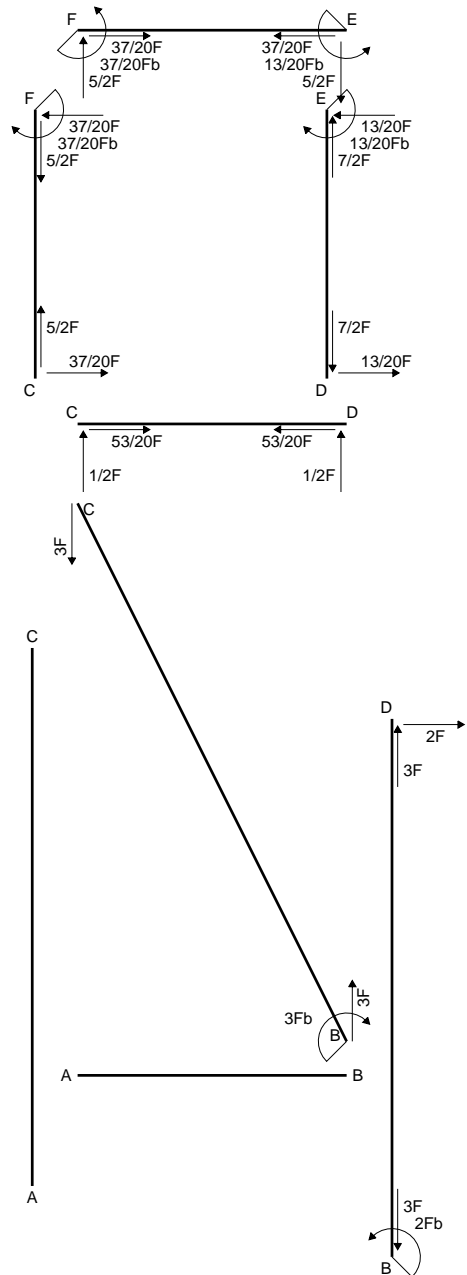

← ⊕ → F

⊕ ⊖ F

⊕ ⊖ F_b

$$L_{DE}^{xx} = \int_0^b (x^2/b^2) 1/EJ dx = [1/3 x^3/b^2]_0^b 1/EJ$$

$$= (1/3 b) 1/EJ = 1/3 b/EJ$$

$$L_{ED}^{xx} = \int_0^b (1 - 2x/b + x^2/b^2) 1/EJ dx = [x - x^2/b + 1/3 x^3/b^2]_0^b 1/EJ$$

$$= (b - b + 1/3 b) 1/EJ = 1/3 b/EJ$$

$$L_{EF}^{xx} = \int_0^b (1) 1/EJ dx = [x]_0^b 1/EJ$$

$$= (b) 1/EJ = b/EJ$$

$$L_{FE}^{xx} = \int_0^b (1) 1/EJ dx = [x]_0^b 1/EJ$$

$$= (b) 1/EJ = b/EJ$$

$$L_{FC}^{xx} = \int_0^b (1 - 2x/b + x^2/b^2) 1/EJ dx = [x - x^2/b + 1/3 x^3/b^2]_0^b 1/EJ$$

$$= (b - b + 1/3 b) 1/EJ = 1/3 b/EJ$$

$$L_{CF}^{xx} = \int_0^b (x^2/b^2) 1/EJ dx = [1/3 x^3/b^2]_0^b 1/EJ$$

$$= (1/3 b) 1/EJ = 1/3 b/EJ$$

$$L_{EF}^{xo} = \int_0^b (-5/2 x/b) Fb 1/EJ dx + \int_0^b (1) \theta dx = [-5/4 x^2/b]_0^b Fb 1/EJ + [x]_0^b \theta$$

$$= (-5/4 b) Fb 1/EJ + (b) \theta = -1/4 Fb^2/EJ$$

$$L_{FE}^{xo} = \int_0^b (-5/2 + 5/2 x/b) Fb 1/EJ dx + \int_0^b (-1) \theta dx = [-5/2 x + 5/4 x^2/b]_0^b Fb 1/EJ + [-x]_0^b \theta$$

$$= (-5/2 b + 5/4 b) Fb 1/EJ + (-b) \theta = -1/4 Fb^2/EJ$$

$$L_{FC}^{xo} = \int_0^b (-5/2 + 5x/b - 5/2 x^2/b^2) Fb 1/EJ dx = [-5/2 x + 5/2 x^2/b - 5/6 x^3/b^2]_0^b Fb 1/EJ$$

$$= (-5/2 b + 5/2 b - 5/6 b) Fb 1/EJ = -5/6 Fb^2/EJ$$

$$L_{CF}^{xo} = \int_0^b (-5/2 x^2/b^2) Fb 1/EJ dx = [-5/6 x^3/b^2]_0^b Fb 1/EJ$$

$$= (-5/6 b) Fb 1/EJ = -5/6 Fb^2/EJ$$

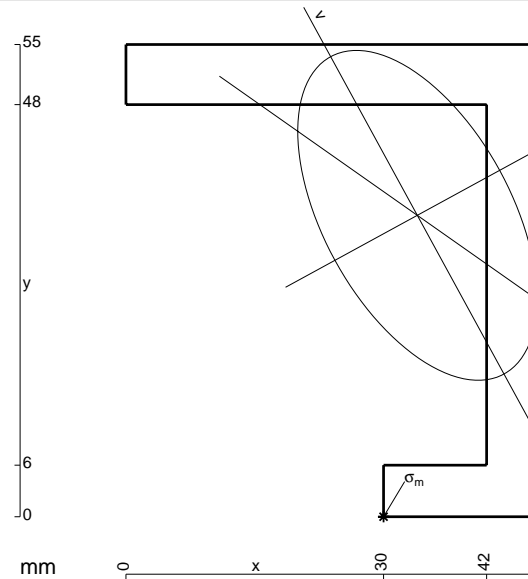

- A = 696. mm²
- J_x = 256929. mm⁴
- J_y = 134973. mm⁴
- J_{xy} = -94891. mm⁴
- J_u = 308745. mm⁴
- J_v = 83156. mm⁴
- α = artg(2J_{xy}/(J_y-J_x))/2 = .4998
- c = cosα = .8777
- s = sinα = .4793
- x_g = 33.93 mm
- y_g = 35.1 mm
- N = -1529. N
- T_y = -764.7 N
- M_x = 1060200. Nmm
- x_m = 30. mm
- u_m = -20.27 mm
- v_m = -28.93 mm
- σ_m = N/A - Mcv/J_u - Msu/J_v = 208.9 N/mm²

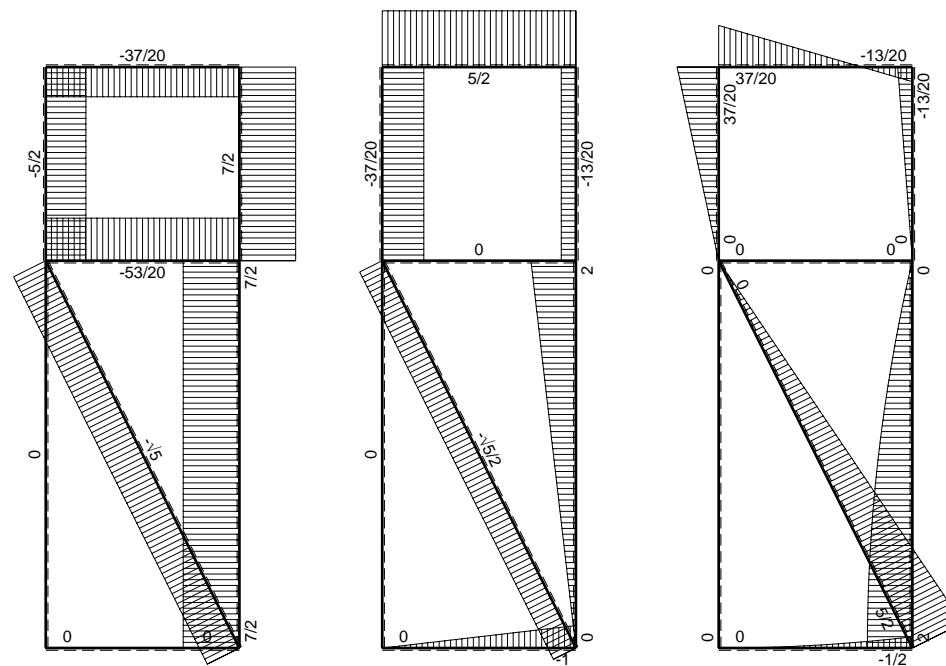
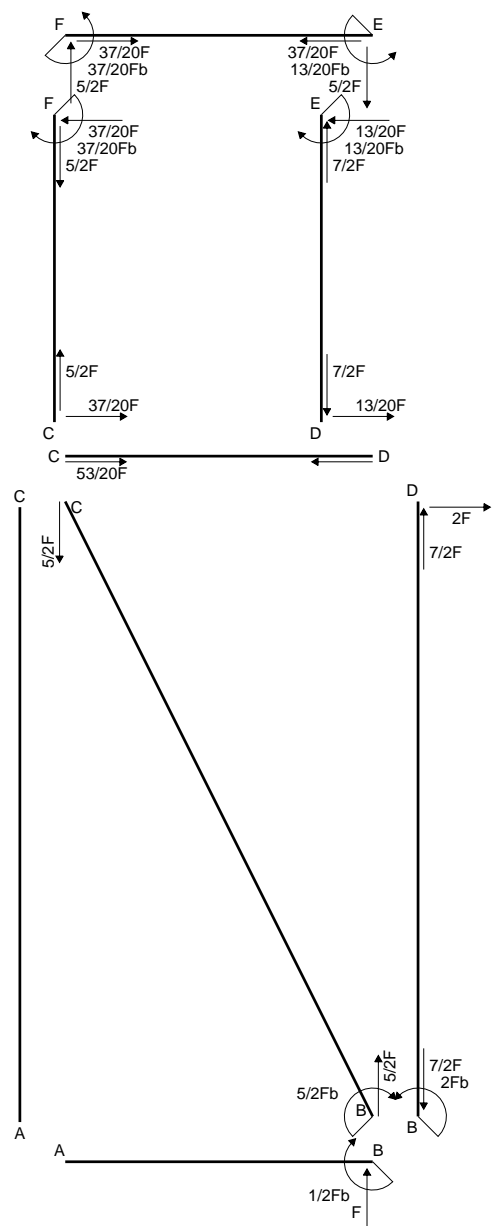

← ⊕ → F

↑ ⊕ ↓ F

⊕ ⊖ F_b

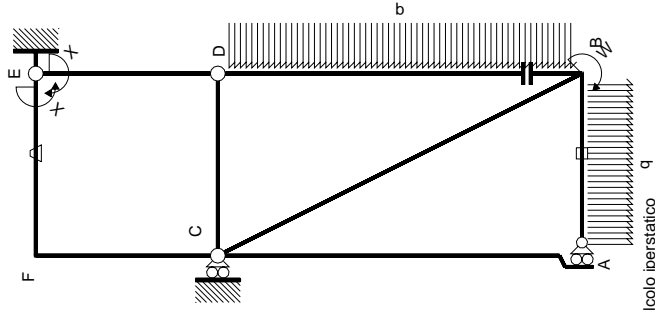

Schema di calcolo iperstatico

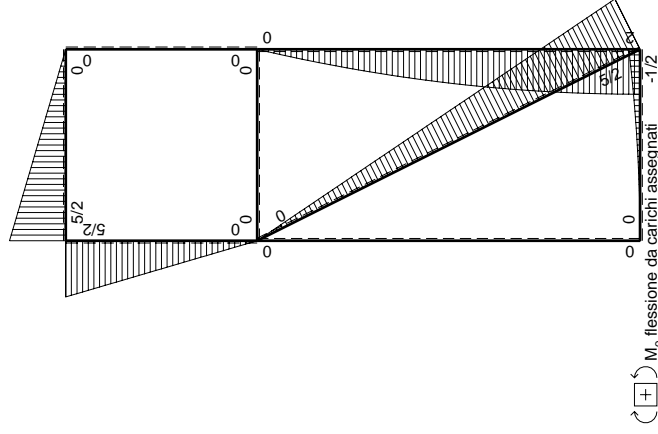

M_0 flessione da carichi assegnati

Quadro contributi PLV per iperstatica $X=W_{EP}$

\rightarrow	$M(x)$	$M_0(x)$	θ	$M_x M_0$	$M_x \theta$	$M_x M_x$	$\int M_x(M_0/EJ+\theta)dx$	$\int M_x M_x/EJ dx$
AB b	0	$-1/2qx^2$	0	0	0	0	0	0
BA b	0	$1/2Fb-Fx+1/2qx^2$	0	0	0	0	0	0
BC $\sqrt{5}b$	0	$5/2Fb-\sqrt{5}2Fx$	0	0	0	0	0	0
CA 2b	0	0	0	0	0	0	0	0
AC 2b	0	0	0	0	0	0	0	0
DB 2b	0	$2Fx-1/2qx^2$	0	0	0	0	0	0
BD 2b	0	$-2Fb+1/2qx^2$	0	0	0	0	0	0
DE b	$-x/b$	0	0	0	0	0	0	0
ED b	$1-x/b$	0	0	0	0	0	0	0
CD b	0	0	0	0	0	0	0	0
DC b	0	0	0	0	0	0	0	0
EF b	-1	$5/2Fx$	$-Fb/EJ$	$-5/2Fx$	Fb/EJ	1	$(-5/4+1)Fb^2/EJ$	Xb/EJ
FE b	1	$-5/2Fb+5/2Fx$	Fb/EJ	$-5/2Fb+5/2Fx$	Fb/EJ	1	$(-5/4+1)Fb^2/EJ$	Xb/EJ
FC b	$-1+x/b$	$5/2Fb-5/2Fx$	0	$-5/2Fb+5Fx-5/2Fx^2/b$	0	$1-2x/b+x^2/b^2$	$(-5/6+0)Fb^2/EJ$	$1/3Xb/EJ$
CF b	x/b	$-5/2Fx$	0	$-5/2Fx^2/b$	0	x^2/b^2	$-13/12Fb^2/EJ$	$5/3Xb/EJ$
totali								
iperstatica $X=W_{EP}$								

Sviluppi di calcolo iperstatica

M_x flessione da iperstatica $X=1$

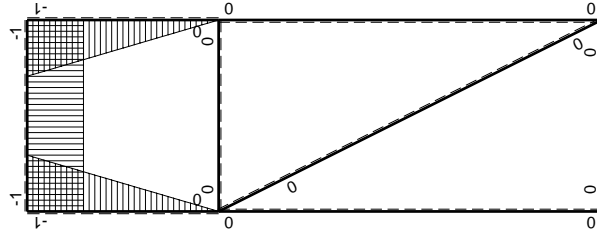

$$L_{DE}^{xx} = \int_0^b (x^2/b^2) 1/EJ dx = [1/3 x^3/b^2]_0^b 1/EJ$$

$$= (1/3 b) 1/EJ = 1/3 b/EJ$$

$$L_{ED}^{xx} = \int_0^b (1 - 2x/b + x^2/b^2) 1/EJ dx = [x - x^2/b + 1/3 x^3/b^2]_0^b 1/EJ$$

$$= (b - b + 1/3 b) 1/EJ = 1/3 b/EJ$$

$$L_{EF}^{xx} = \int_0^b (1) 1/EJ dx = [x]_0^b 1/EJ$$

$$= (b) 1/EJ = b/EJ$$

$$L_{FE}^{xx} = \int_0^b (1) 1/EJ dx = [x]_0^b 1/EJ$$

$$= (b) 1/EJ = b/EJ$$

$$L_{FC}^{xx} = \int_0^b (1 - 2x/b + x^2/b^2) 1/EJ dx = [x - x^2/b + 1/3 x^3/b^2]_0^b 1/EJ$$

$$= (b - b + 1/3 b) 1/EJ = 1/3 b/EJ$$

$$L_{CF}^{xx} = \int_0^b (x^2/b^2) 1/EJ dx = [1/3 x^3/b^2]_0^b 1/EJ$$

$$= (1/3 b) 1/EJ = 1/3 b/EJ$$

$$L_{EF}^{x\theta} = \int_0^b (-5/2 x/b) Fb 1/EJ dx + \int_0^b (1) \theta dx = [-5/4 x^2/b]_0^b Fb 1/EJ + [x]_0^b \theta$$

$$= (-5/4 b) Fb 1/EJ + (b) \theta = -1/4 Fb^2/EJ$$

$$L_{FE}^{x\theta} = \int_0^b (-5/2 + 5/2 x/b) Fb 1/EJ dx + \int_0^b (-1) \theta dx = [-5/2 x + 5/4 x^2/b]_0^b Fb 1/EJ + [-x]_0^b \theta$$

$$= (-5/2 b + 5/4 b) Fb 1/EJ + (-b) \theta = -1/4 Fb^2/EJ$$

$$L_{FC}^{x\theta} = \int_0^b (-5/2 + 5x/b - 5/2 x^2/b^2) Fb 1/EJ dx = [-5/2 x + 5/2 x^2/b - 5/6 x^3/b^2]_0^b Fb 1/EJ$$

$$= (-5/2 b + 5/2 b - 5/6 b) Fb 1/EJ = -5/6 Fb^2/EJ$$

$$L_{CF}^{x\theta} = \int_0^b (-5/2 x^2/b^2) Fb 1/EJ dx = [-5/6 x^3/b^2]_0^b Fb 1/EJ$$

$$= (-5/6 b) Fb 1/EJ = -5/6 Fb^2/EJ$$

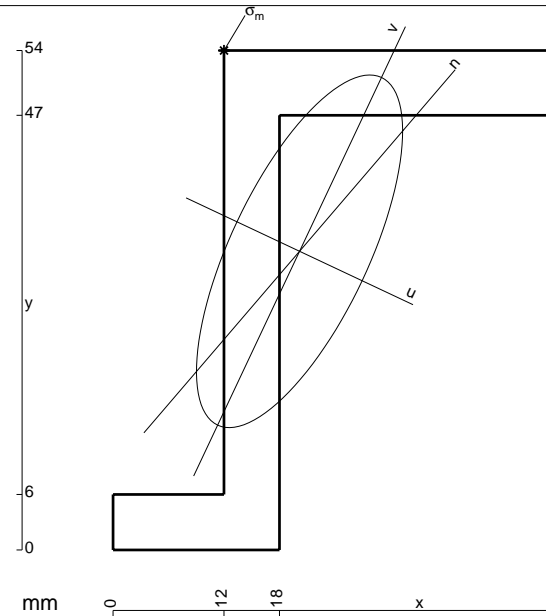

$A = 606. \text{ mm}^2$
 $J_x = 220278. \text{ mm}^4$
 $J_y = 75271. \text{ mm}^4$
 $J_{xy} = 87807. \text{ mm}^4$
 $J_u = 261647. \text{ mm}^4$
 $J_v = 33902. \text{ mm}^4$
 $\alpha = \text{artg}(2J_{xy}/(J_y - J_x))/2 = -.4403$
 $c = \cos\alpha = .9046$
 $s = \sin\alpha = -.4262$
 $x_g = 20.17 \text{ mm}$
 $y_g = 32.29 \text{ mm}$
 $N = -1140. \text{ N}$
 $T_y = -570.2 \text{ N}$
 $M_x = 816000. \text{ Nmm}$
 $x_m = 12. \text{ mm}$
 $y_m = 54. \text{ mm}$
 $u_m = -16.64 \text{ mm}$
 $v_m = 16.16 \text{ mm}$
 $\sigma_m = N/A - Mcv/J_u - Msu/J_v = -218.2 \text{ N/mm}^2$

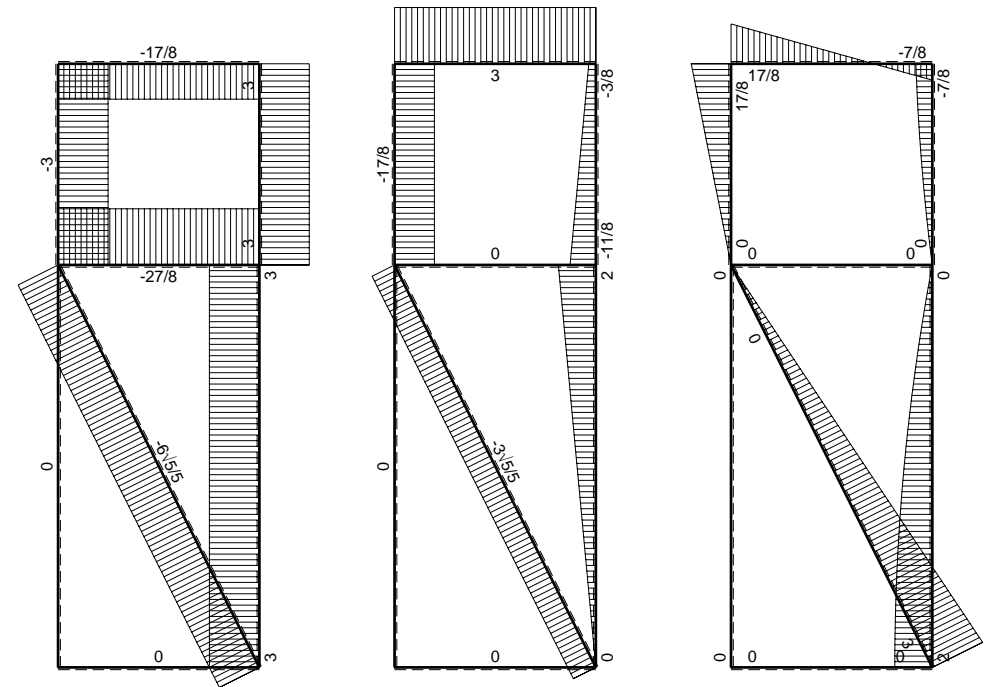
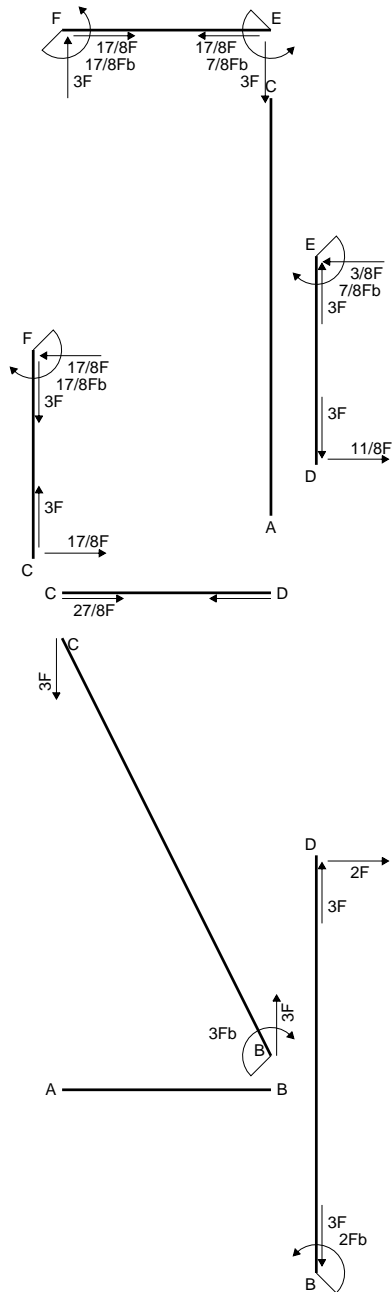

← ⊕ → F

↑ ⊕ ↓ F

⊕ ⊖ F_b

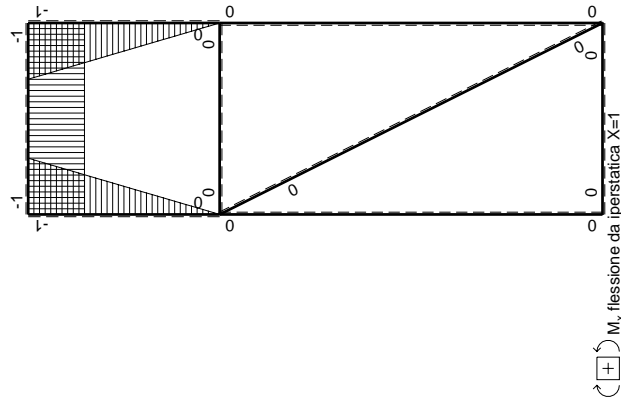
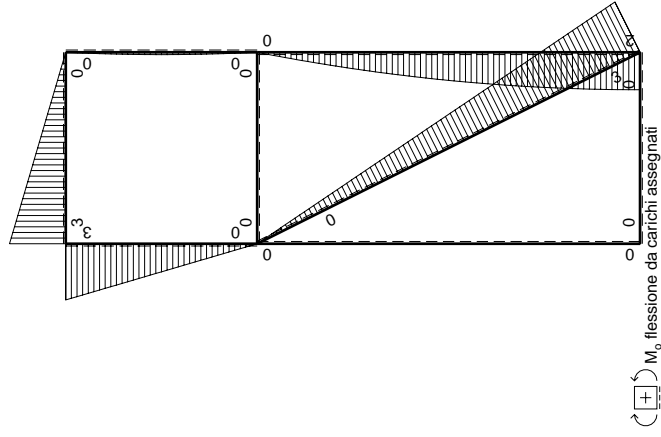
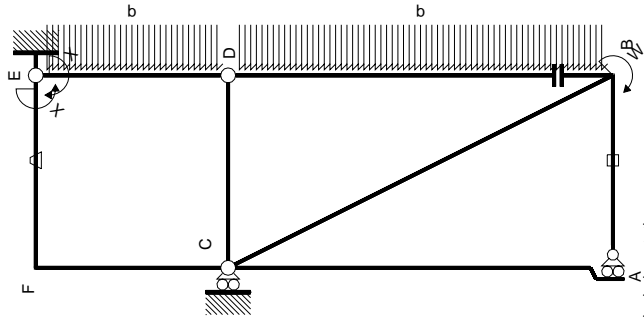

Quadro contributi PLV per iperstatica $X=W_{EF}$

\leftarrow	$M^x(x)$	$M^0(x)$	θ	$M^x M_0$	$M^x \theta$	$M^x M_x$	$\int M^x (M_0/EJ + \theta) dx$	$\int M^x M_x / EJ dx$
AB b	0	0	0	0	0	0	0+0	0
BA b	0	0	0	0	0	0	0	0
BC $\sqrt{5}b$	0	$3Fb-3\sqrt{5}/5Fx$	0	0	0	0	0+0	0
AC 2b	0	0	0	0	0	0	0+0	0
CA 2b	0	0	0	0	0	0	0+0	0
DB 2b	0	$2Fx-1/2qx^2$	0	0	0	0	0+0	0
BD 2b	0	$-2Fb+1/2qx^2$	0	0	0	0	0+0	0
DE b	$-x/b$	$-1/2Fx+1/2qx^2$	0	$1/2Fx^2/b-1/2qx^3/b$	0	x^2/b^2	$(1/2+0)Fb^2/EJ$	$1/3Xb/EJ$
ED b	$1-x/b$	$1/2Fx-1/2qx^2$	0	$1/2Fx-Fx^2/b+1/2qx^3/b$	0	$1-2x/b+x^2/b^2$	$(1/2+0)Fb^2/EJ$	$1/3Xb/EJ$
CD b	0	0	0	0	0	0	0+0	0
DC b	0	0	0	0	0	0	0+0	0
EF b	-1	$3Fx$	$-Fb/EJ$	$-3Fx$	Fb/EJ	1	$(-3/2+1)Fb^2/EJ$	Xb/EJ
FE b	1	$-3Fb+3Fx$	Fb/EJ	$-3Fb+3Fx$	Fb/EJ	1	$(-3/2+1)Fb^2/EJ$	Xb/EJ
FC b	$-1+x/b$	$3Fb-3Fx$	0	$-3Fb+6Fx-3Fx^2/b$	0	$1-2x/b+x^2/b^2$	$(-1+0)Fb^2/EJ$	$1/3Xb/EJ$
CF b	x/b	$-3Fx$	0	$-3Fx^2/b$	0	x^2/b^2	$-35/24Fb^2/EJ$	$5/3Xb/EJ$
totali								
iperstatica $X=W_{EF}$							$7/8Fb$	

Sviluppi di calcolo iperstatica

$$L_{DE}^{xx} = \int_0^b (x^2/b^2) 1/EJ dx = [1/3 x^3/b^2]_0^b 1/EJ$$

$$= (1/3 b) 1/EJ = 1/3 b/EJ$$

$$L_{ED}^{xx} = \int_0^b (1 - 2x/b + x^2/b^2) 1/EJ dx = [x - x^2/b + 1/3 x^3/b^2]_0^b 1/EJ$$

$$= (b - b + 1/3 b) 1/EJ = 1/3 b/EJ$$

$$L_{EF}^{xx} = \int_0^b (1) 1/EJ dx = [x]_0^b 1/EJ$$

$$= (b) 1/EJ = b/EJ$$

$$L_{FE}^{xx} = \int_0^b (1) 1/EJ dx = [x]_0^b 1/EJ$$

$$= (b) 1/EJ = b/EJ$$

$$L_{FC}^{xx} = \int_0^b (1 - 2x/b + x^2/b^2) 1/EJ dx = [x - x^2/b + 1/3 x^3/b^2]_0^b 1/EJ$$

$$= (b - b + 1/3 b) 1/EJ = 1/3 b/EJ$$

$$L_{CF}^{xx} = \int_0^b (x^2/b^2) 1/EJ dx = [1/3 x^3/b^2]_0^b 1/EJ$$

$$= (1/3 b) 1/EJ = 1/3 b/EJ$$

$$L_{DE}^{xo} = \int_0^b (1/2 x^2/b^2 - 1/2 x^3/b^3) Fb 1/EJ dx = [1/6 x^3/b^2 - 1/8 x^4/b^3]_0^b Fb 1/EJ$$

$$= (1/6 b - 1/8 b) Fb 1/EJ = 1/24 Fb^2/EJ$$

$$L_{ED}^{xo} = \int_0^b (1/2 x/b - x^2/b^2 + 1/2 x^3/b^3) Fb 1/EJ dx = [1/4 x^2/b - 1/3 x^3/b^2 + 1/8 x^4/b^3]_0^b Fb 1/EJ$$

$$= (1/4 b - 1/3 b + 1/8 b) Fb 1/EJ = 1/24 Fb^2/EJ$$

$$L_{EF}^{xo} = \int_0^b (-3x/b) Fb 1/EJ dx + \int_0^b (1) \theta dx = [-3/2 x^2/b]_0^b Fb 1/EJ + [x]_0^b \theta$$

$$= (-3/2 b) Fb 1/EJ + (b) \theta = -1/2 Fb^2/EJ$$

$$L_{FE}^{xo} = \int_0^b (-3 + 3x/b) Fb 1/EJ dx + \int_0^b (-1) \theta dx = [-3x + 3/2 x^2/b]_0^b Fb 1/EJ + [-x]_0^b \theta$$

$$= (-3b + 3/2 b) Fb 1/EJ + (-b) \theta = -1/2 Fb^2/EJ$$

$$L_{FC}^{xo} = \int_0^b (-3 + 6x/b - 3x^2/b^2) Fb 1/EJ dx = [-3x + 3x^2/b - x^3/b^2]_0^b Fb 1/EJ$$

$$= (-3b + 3b - b) Fb 1/EJ = - Fb^2/EJ$$

$$L_{CF}^{xo} = \int_0^b (-3x^2/b^2) Fb 1/EJ dx = [-x^3/b^2]_0^b Fb 1/EJ$$

$$= (-b) Fb 1/EJ = - Fb^2/EJ$$

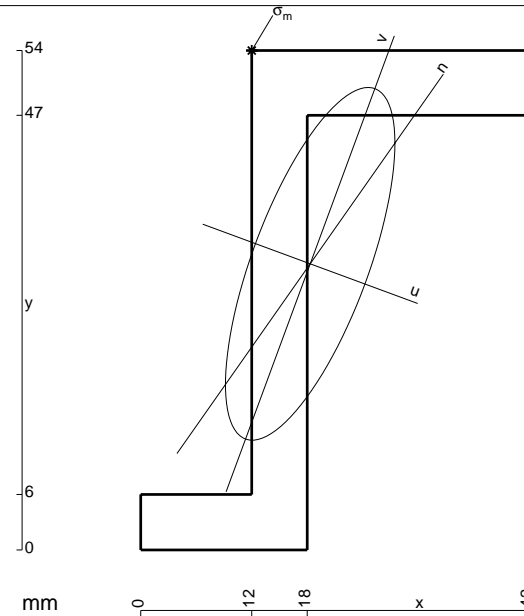

$$A = 564. \text{ mm}^2$$

$$J_x = 205146. \text{ mm}^4$$

$$J_y = 47319. \text{ mm}^4$$

$$J_{xy} = 67404. \text{ mm}^4$$

$$J_u = 230014. \text{ mm}^4$$

$$J_v = 22451. \text{ mm}^4$$

$$\alpha = \text{artg}(2J_{xy}/(J_y - J_x))/2 = -.3534$$

$$c = \cos \alpha = .9382$$

$$s = \sin \alpha = -.3461$$

$$x_g = 18.32 \text{ mm}$$

$$y_g = 30.94 \text{ mm}$$

$$N = -1020. \text{ N}$$

$$T_y = -509.8 \text{ N}$$

$$M_x = 775200. \text{ Nmm}$$

$$x_m = 12. \text{ mm}$$

$$y_m = 54. \text{ mm}$$

$$u_m = -13.91 \text{ mm}$$

$$v_m = 19.45 \text{ mm}$$

$$\sigma_m = N/A - Mcv/J_u - Msu/J_v = -229.6 \text{ N/mm}^2$$

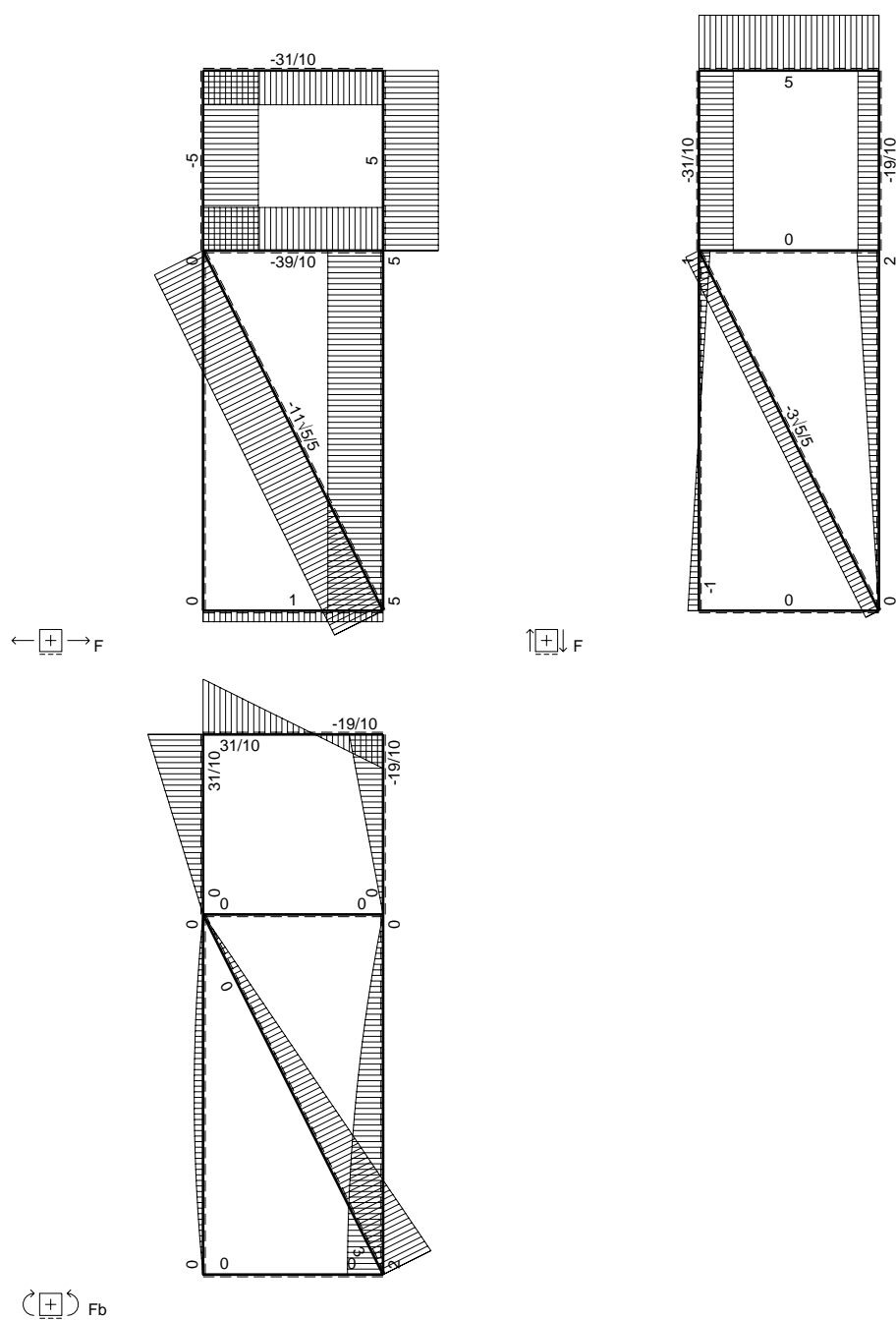
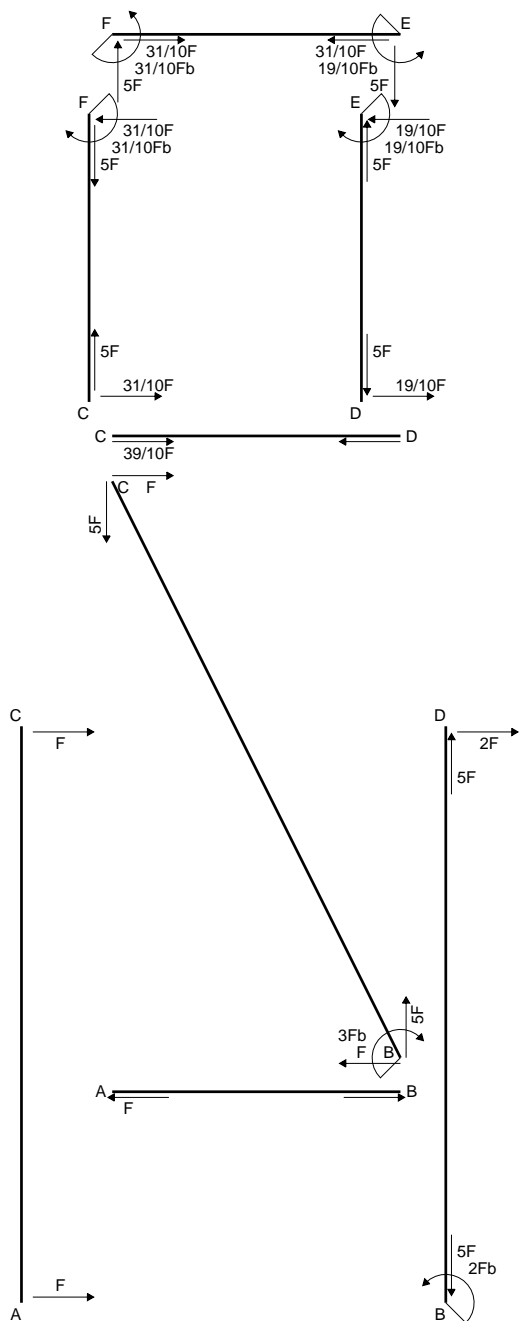

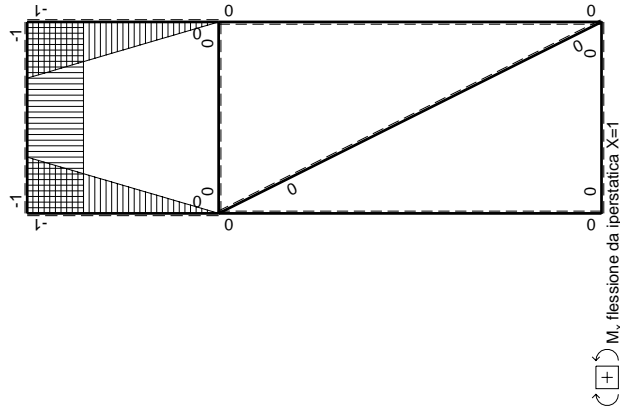
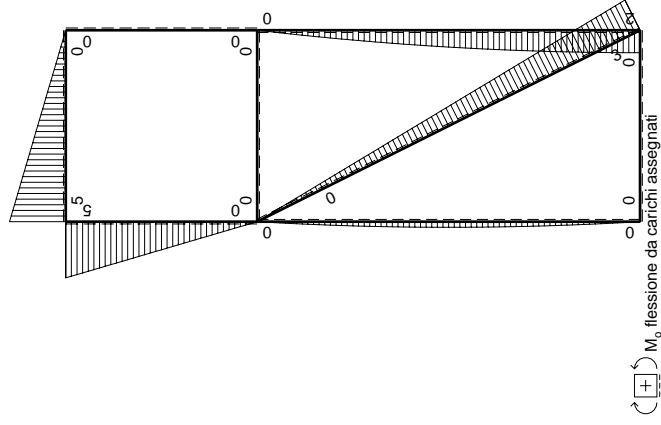
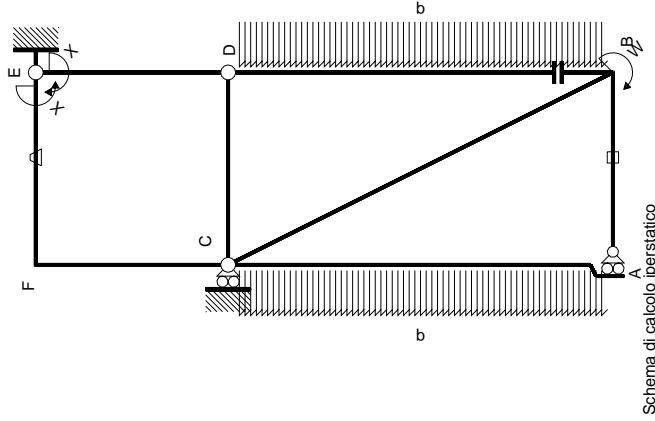

Quadro contributi PLV per iperstatica $X=W_{Ef}$

\rightarrow	$M^x(x)$	$M^0(x)$	θ	$M^x M_0$	$M^x \theta$	$M^x M_x$	$\int M^x (M_0/EJ + \theta) dx$	$\int M^x M_x / E J dx$
AB b	0	0	0	0	0	0	0	0
BA b	0	0	0	0	0	0	0	0
BC $\sqrt{5}b$	0	$3Fb-3\sqrt{5}/5Fx$	0	0	0	0	0	0
AC 2b	0	$-Fx+1/2qx^2$	0	0	0	0	0	0
CA 2b	0	$Fx-1/2qx^2$	0	0	0	0	0	0
DB 2b	0	$2Fx-1/2qx^2$	0	0	0	0	0	0
BD 2b	0	$-2Fb+1/2qx^2$	0	0	0	0	0	0
DE b	$-x/b$	0	0	0	0	x^2/b^2	0	$1/3Xb/EJ$
ED b	$1-x/b$	0	0	0	0	$1-2x/b+x^2/b^2$	0	$1/3Xb/EJ$
CD b	0	0	0	0	0	0	0	0
DC b	0	0	0	0	0	0	0	0
EF b	-1	$5Fx$	$-Fb/EJ$	$-5Fx$	Fb/EJ	1	$(-5/2+1)Fb^2/EJ$	Xb/EJ
FE b	1	$-5Fb+5Fx$	Fb/EJ	$-5Fb+5Fx$	Fb/EJ	1	$(-5/2+1)Fb^2/EJ$	Xb/EJ
FC b	$-1+x/b$	$5Fb-5Fx$	0	$-5Fb+10Fx-5Fx^2/b$	0	$1-2x/b+x^2/b^2$	$(-5/3+0)Fb^2/EJ$	$1/3Xb/EJ$
CF b	x/b	$-5Fx$	0	$-5Fx^2/b$	0	x^2/b^2	$-19/6Fb^2/EJ$	$5/3Xb/EJ$
totali								
								$19/10Fb$

Sviluppi di calcolo iperstatica

$$L_{DE}^{xx} = \int_0^b (x^2/b^2) 1/EJ dx = [1/3 x^3/b^2]_0^b 1/EJ$$

$$= (1/3 b) 1/EJ = 1/3 b/EJ$$

$$L_{ED}^{xx} = \int_0^b (1 - 2x/b + x^2/b^2) 1/EJ dx = [x - x^2/b + 1/3 x^3/b^2]_0^b 1/EJ$$

$$= (b - b + 1/3 b) 1/EJ = 1/3 b/EJ$$

$$L_{EF}^{xx} = \int_0^b (1) 1/EJ dx = [x]_0^b 1/EJ$$

$$= (b) 1/EJ = b/EJ$$

$$L_{FE}^{xx} = \int_0^b (1) 1/EJ dx = [x]_0^b 1/EJ$$

$$= (b) 1/EJ = b/EJ$$

$$L_{FC}^{xx} = \int_0^b (1 - 2x/b + x^2/b^2) 1/EJ dx = [x - x^2/b + 1/3 x^3/b^2]_0^b 1/EJ$$

$$= (b - b + 1/3 b) 1/EJ = 1/3 b/EJ$$

$$L_{CF}^{xx} = \int_0^b (x^2/b^2) 1/EJ dx = [1/3 x^3/b^2]_0^b 1/EJ$$

$$= (1/3 b) 1/EJ = 1/3 b/EJ$$

$$L_{EF}^{xo} = \int_0^b (-5x/b) Fb 1/EJ dx + \int_0^b (1) \theta dx = [-5/2 x^2/b]_0^b Fb 1/EJ + [x]_0^b \theta$$

$$= (-5/2 b) Fb 1/EJ + (b) \theta = -3/2 Fb^2/EJ$$

$$L_{FE}^{xo} = \int_0^b (-5 + 5x/b) Fb 1/EJ dx + \int_0^b (-1) \theta dx = [-5x + 5/2 x^2/b]_0^b Fb 1/EJ + [-x]_0^b \theta$$

$$= (-5b + 5/2 b) Fb 1/EJ + (-b) \theta = -3/2 Fb^2/EJ$$

$$L_{FC}^{xo} = \int_0^b (-5 + 10x/b - 5x^2/b^2) Fb 1/EJ dx = [-5x + 5x^2/b - 5/3 x^3/b^2]_0^b Fb 1/EJ$$

$$= (-5b + 5b - 5/3 b) Fb 1/EJ = -5/3 Fb^2/EJ$$

$$L_{CF}^{xo} = \int_0^b (-5x^2/b^2) Fb 1/EJ dx = [-5/3 x^3/b^2]_0^b Fb 1/EJ$$

$$= (-5/3 b) Fb 1/EJ = -5/3 Fb^2/EJ$$

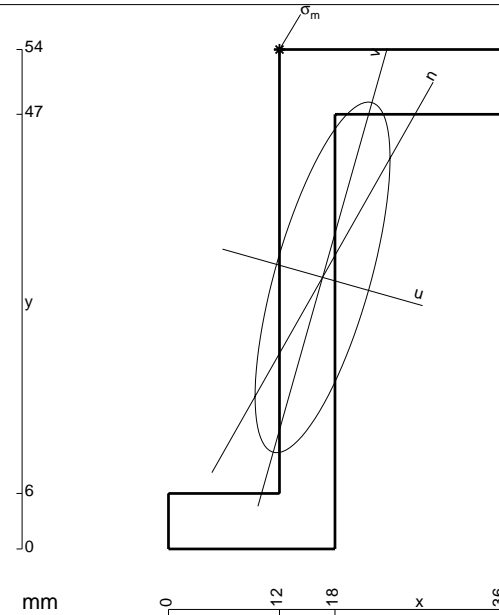

$$A = 522. \text{ mm}^2$$

$$J_x = 187606. \text{ mm}^4$$

$$J_y = 27784. \text{ mm}^4$$

$$J_{xy} = 49043. \text{ mm}^4$$

$$J_u = 201455. \text{ mm}^4$$

$$J_v = 13935. \text{ mm}^4$$

$$\alpha = \text{artg}(2J_{xy}/(J_y - J_x))/2 = -.2752$$

$$c = \cos \alpha = .9624$$

$$s = \sin \alpha = -.2718$$

$$x_g = 16.66 \text{ mm}$$

$$y_g = 29.36 \text{ mm}$$

$$N = -1600. \text{ N}$$

$$T_y = -992. \text{ N}$$

$$M_x = 714240. \text{ Nmm}$$

$$x_m = 12. \text{ mm}$$

$$y_m = 54. \text{ mm}$$

$$u_m = -11.18 \text{ mm}$$

$$v_m = 22.45 \text{ mm}$$

$$\sigma_m = N/A - Mcv/J_u - Msu/J_v = -235.3 \text{ N/mm}^2$$

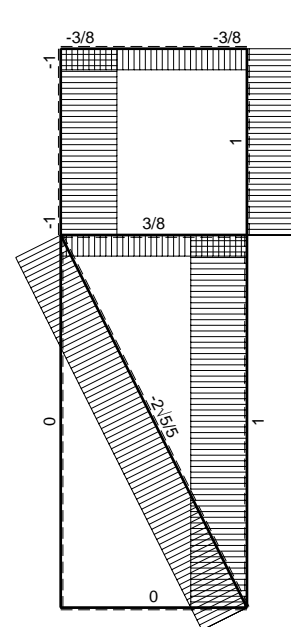
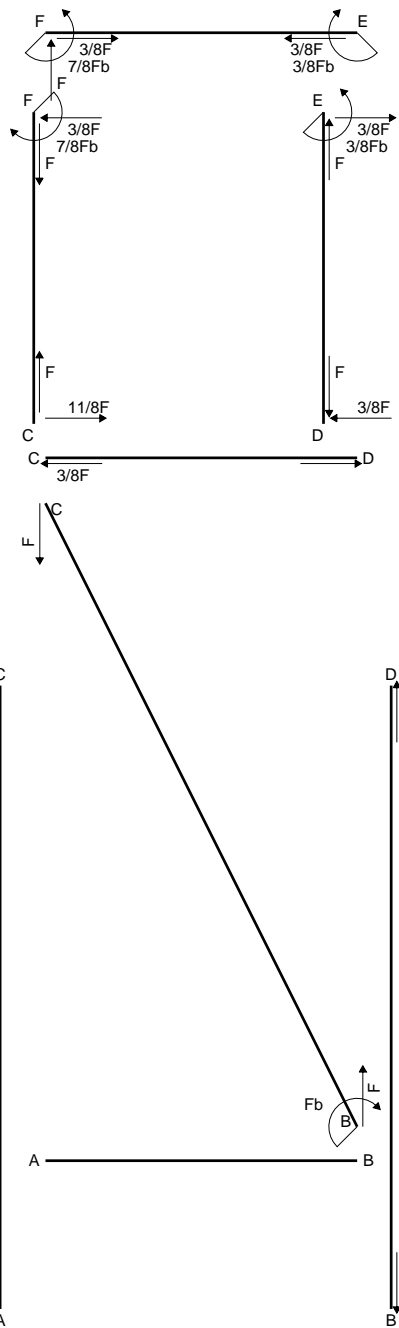

← ⊕ → F

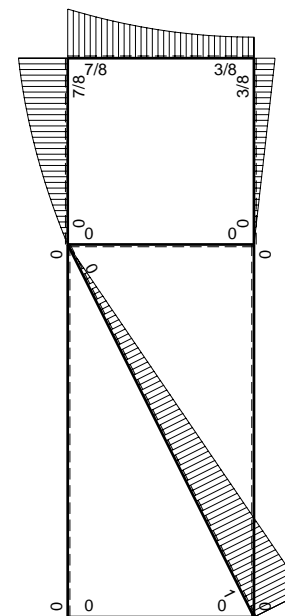

⊕ ⊖ F_b

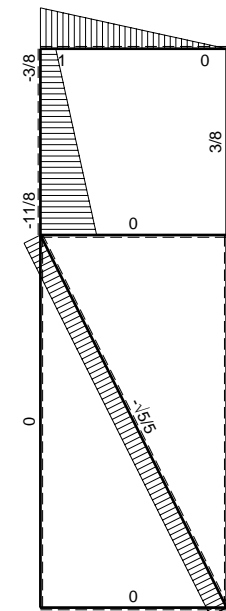

↑ ⊕ ↓ F

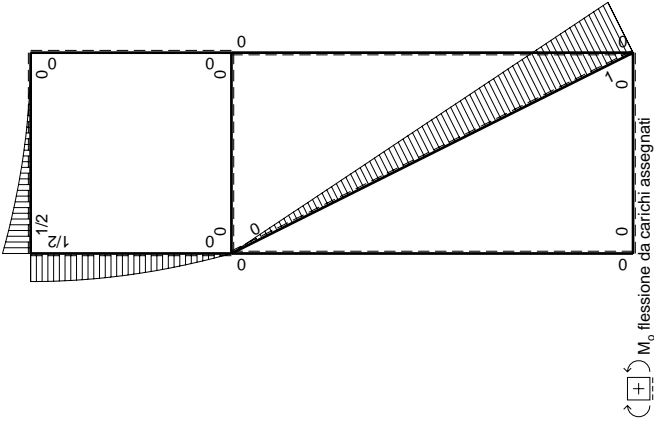
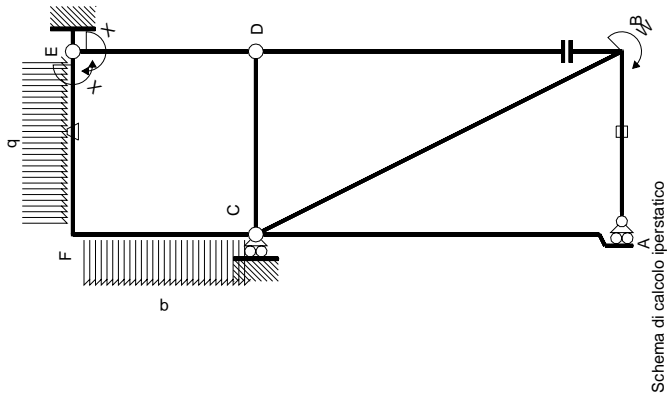

Quadro contributi PLV per iperstatica $X=W_{EF}$

\leftarrow	$M(x)$	$M_0(x)$	θ	M_x^0	M_x^{θ}	M_x^X	$\int M_x(M_0/EJ+\theta)dx$	$\int M_x M_x/EJdx$
AB	0	0	0	0	0	0	0+0	0
BA	0	0	0	0	0	0	0	0
BC	0	$Fb-\sqrt{5}/5Fx$	0	0	0	0	0+0	0
AC	0	0	0	0	0	0	0+0	0
CA	0	0	0	0	0	0	0+0	0
DB	0	0	0	0	0	0	0+0	0
BD	0	0	0	0	0	0	0+0	0
DE	-x/b	0	0	0	0	x^2/b^2	0+0	0
ED	1-x/b	0	0	0	0	$1-2x/b+x^2/b^2$	0+0	$1/3Xb/EJ$
CD	0	0	0	0	0	0	0+0	0
DC	0	0	0	0	0	0	0+0	0
EF	-1	$1/2qx^2$	$-Fb/EJ$	$-1/2Fx^2/b$	Fb/EJ	1	$(-1/6+1)Fb^2/EJ$	Xb/EJ
FE	1	$-1/2Fb+Fx-1/2qx^2$	Fb/EJ	$-1/2Fb+Fx-1/2Fx^2/b$	Fb/EJ	1	$(-1/6+1)Fb^2/EJ$	Xb/EJ
FC	$-1+x/b$	$1/2Fb-1/2qx^2$	0	$-1/2Fb+1/2Fx+1/2Fx^2/b-1/2qx^3/b$	0	$1-2x/b+x^2/b^2$	$(-5/24+0)Fb^2/EJ$	$1/3Xb/EJ$
CF	x/b	$-Fx+1/2qx^2$	0	$-Fx^2/b+1/2qx^3/b$	0	x^2/b^2	$(-5/24+0)Fb^2/EJ$	$1/3Xb/EJ$
totali							$5/8Fb^2/EJ$	$5/3Xb/EJ$
								$-3/8Fb$

Sviluppi di calcolo iperstatica

$$L_{DE}^{xx} = \int_0^b (x^2/b^2) 1/EJ dx = [1/3 x^3/b^2]_0^b 1/EJ$$

$$= (1/3 b) 1/EJ = 1/3 b/EJ$$

$$L_{ED}^{xx} = \int_0^b (1 - 2x/b + x^2/b^2) 1/EJ dx = [x - x^2/b + 1/3 x^3/b^2]_0^b 1/EJ$$

$$= (b - b + 1/3 b) 1/EJ = 1/3 b/EJ$$

$$L_{EF}^{xx} = \int_0^b (1) 1/EJ dx = [x]_0^b 1/EJ$$

$$= (b) 1/EJ = b/EJ$$

$$L_{FE}^{xx} = \int_0^b (1) 1/EJ dx = [x]_0^b 1/EJ$$

$$= (b) 1/EJ = b/EJ$$

$$L_{FC}^{xx} = \int_0^b (1 - 2x/b + x^2/b^2) 1/EJ dx = [x - x^2/b + 1/3 x^3/b^2]_0^b 1/EJ$$

$$= (b - b + 1/3 b) 1/EJ = 1/3 b/EJ$$

$$L_{CF}^{xx} = \int_0^b (x^2/b^2) 1/EJ dx = [1/3 x^3/b^2]_0^b 1/EJ$$

$$= (1/3 b) 1/EJ = 1/3 b/EJ$$

$$L_{EF}^{xo} = \int_0^b (-1/2 x^2/b^2) Fb 1/EJ dx + \int_0^b (1) \theta dx = [-1/6 x^3/b^2]_0^b Fb 1/EJ + [x]_0^b \theta$$

$$= (-1/6 b) Fb 1/EJ + (b) \theta = 5/6 Fb^2/EJ$$

$$L_{FE}^{xo} = \int_0^b (-1/2 + x/b - 1/2 x^2/b^2) Fb 1/EJ dx + \int_0^b (-1) \theta dx$$

$$= [-1/2 x + 1/2 x^2/b - 1/6 x^3/b^2]_0^b Fb 1/EJ + [-x]_0^b \theta$$

$$= (-1/2 b + 1/2 b - 1/6 b) Fb 1/EJ + (-b) \theta = 5/6 Fb^2/EJ$$

$$L_{FC}^{xo} = \int_0^b (-1/2 + 1/2 x/b + 1/2 x^2/b^2 - 1/2 x^3/b^3) Fb 1/EJ dx$$

$$= [-1/2 x + 1/4 x^2/b + 1/6 x^3/b^2 - 1/8 x^4/b^3]_0^b Fb 1/EJ$$

$$= (-1/2 b + 1/4 b + 1/6 b - 1/8 b) Fb 1/EJ = -5/24 Fb^2/EJ$$

$$L_{CF}^{xo} = \int_0^b (-x^2/b^2 + 1/2 x^3/b^3) Fb 1/EJ dx = [-1/3 x^3/b^2 + 1/8 x^4/b^3]_0^b Fb 1/EJ$$

$$= (-1/3 b + 1/8 b) Fb 1/EJ = -5/24 Fb^2/EJ$$

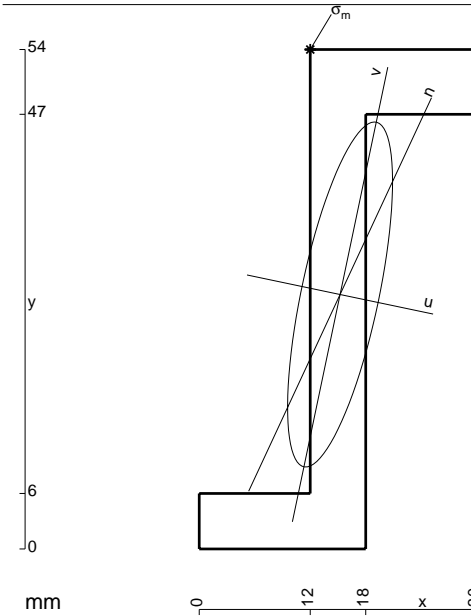

- A = 480. mm²
- J_x = 167026. mm⁴
- J_y = 15456. mm⁴
- J_{xy} = 33263. mm⁴
- J_u = 174004. mm⁴
- J_v = 8477. mm⁴
- α = arctg(2J_{xy}/(J_y-J_x))/2 = -.2068
- c = cos α = .9787
- s = sin α = -.2053
- x_g = 15.23 mm
- y_g = 27.51 mm
- N = -1324. N
- T_y = -661.9 N
- M_x = 562400. Nmm
- x_m = 12. mm
- y_m = 54. mm
- u_m = -8.595 mm
- v_m = 25.26 mm
- σ_m = N/A - Mcv/J_u - Msu/J_v = -199.7 N/mm²

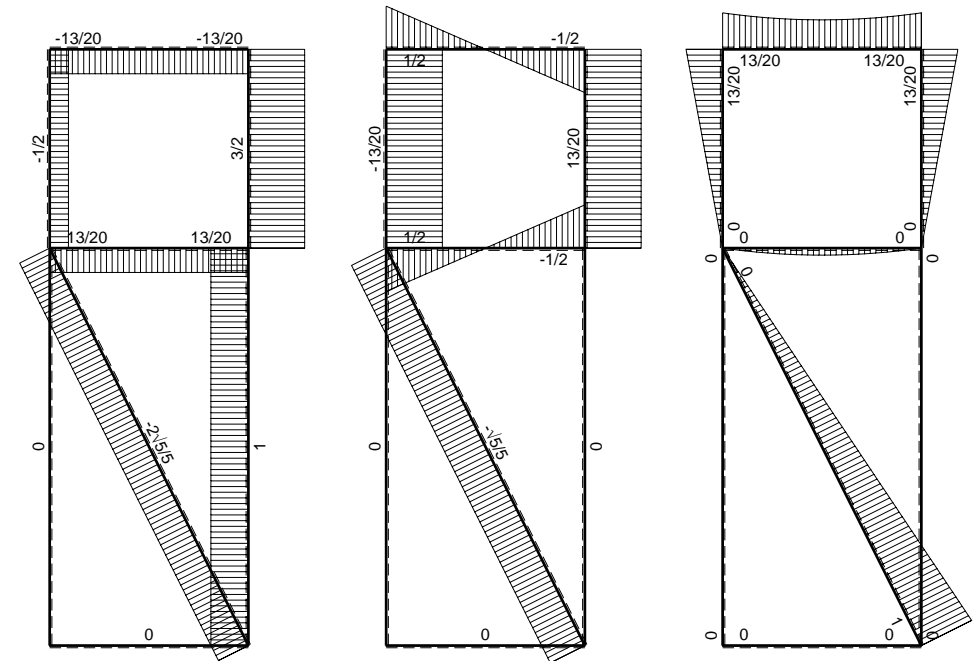
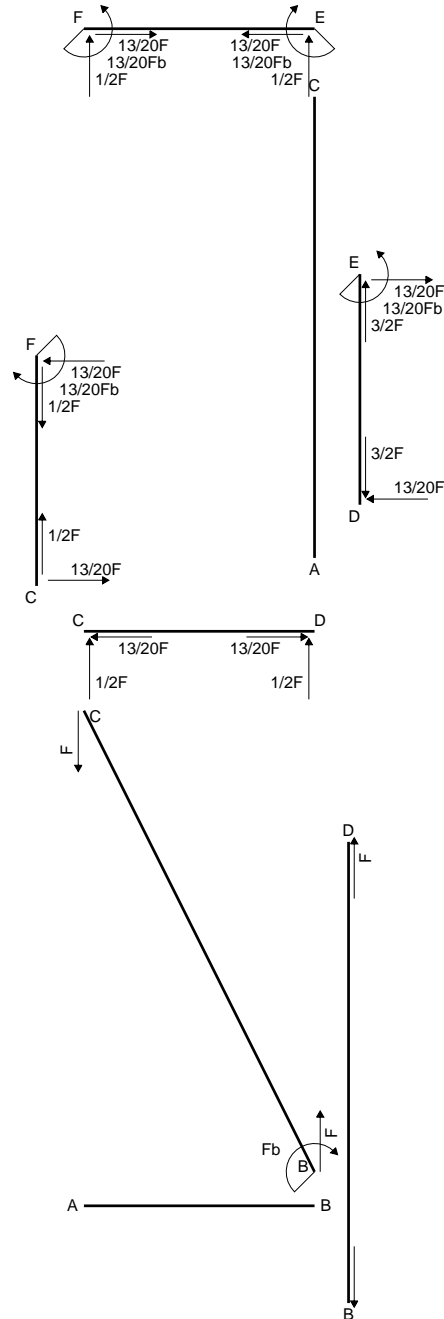

← ⊕ → F

↑ ⊕ ↓ F

⊕ ⊖ F_b

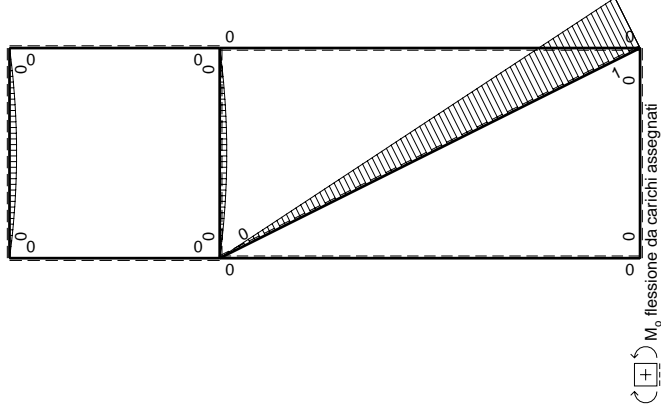
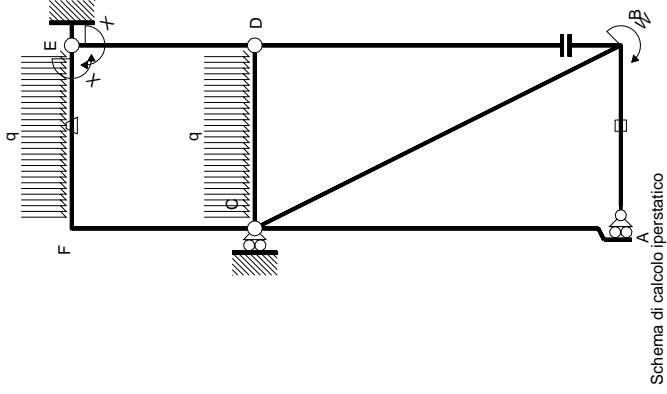

Quadro contributi PLV per iperstatica $X=W_{EF}$

\leftarrow	$M^x(x)$	$M^0(x)$	θ	M^x_0	M^x_θ	M^x_X	$\int M^x(M^0/EJ+\theta)dx$	$\int M^x M^x/EJdx$
AB b	0	0	0	0	0	0	0+0	0
BA b	0	0	0	0	0	0	0	0
BC $\sqrt{5}b$	0	$Fb-\sqrt{5}/5Fx$	0	0	0	0	0	0
AC 2b	0	0	0	0	0	0	0+0	0
BD 2b	0	0	0	0	0	0	0+0	0
DB 2b	0	0	0	0	0	0	0+0	0
DE b	-x/b	0	0	0	0	x^2/b^2	0+0	1/3Xb/EJ
ED b	1-x/b	0	0	0	0	$1-2x/b+x^2/b^2$	0+0	1/3Xb/EJ
CD b	0	$1/2Fx-1/2qx^2$	0	0	0	0	0+0	0
DC b	0	$-1/2Fx+1/2qx^2$	0	0	0	0	0+0	0
EF b	-1	$-1/2Fx+1/2qx^2$	$-Fb/EJ$	$1/2Fx-1/2Fx^2/b$	Fb/EJ	1	$(1/12+1)Fb^2/EJ$	Xb/EJ
FE b	1	$1/2Fx-1/2qx^2$	Fb/EJ	$1/2Fx-1/2Fx^2/b$	Fb/EJ	1	$(1/12+1)Fb^2/EJ$	Xb/EJ
FC b	-1+x/b	0	0	0	0	$1-2x/b+x^2/b^2$	0+0	1/3Xb/EJ
CF b	x/b	0	0	0	0	x^2/b^2	0+0	1/3Xb/EJ
totali							$13/12Fb^2/EJ$	$5/3Xb/EJ$
								$-13/20Fb$

Sviluppi di calcolo iperstatica

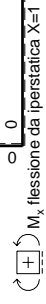

$$L_{DE}^{xx} = \int_0^b (x^2/b^2) 1/EJ dx = [1/3 x^3/b^2]_0^b 1/EJ$$

$$= (1/3 b) 1/EJ = 1/3 b/EJ$$

$$L_{ED}^{xx} = \int_0^b (1 - 2x/b + x^2/b^2) 1/EJ dx = [x - x^2/b + 1/3 x^3/b^2]_0^b 1/EJ$$

$$= (b - b + 1/3 b) 1/EJ = 1/3 b/EJ$$

$$L_{EF}^{xx} = \int_0^b (1) 1/EJ dx = [x]_0^b 1/EJ$$

$$= (b) 1/EJ = b/EJ$$

$$L_{FE}^{xx} = \int_0^b (1) 1/EJ dx = [x]_0^b 1/EJ$$

$$= (b) 1/EJ = b/EJ$$

$$L_{FC}^{xx} = \int_0^b (1 - 2x/b + x^2/b^2) 1/EJ dx = [x - x^2/b + 1/3 x^3/b^2]_0^b 1/EJ$$

$$= (b - b + 1/3 b) 1/EJ = 1/3 b/EJ$$

$$L_{CF}^{xx} = \int_0^b (x^2/b^2) 1/EJ dx = [1/3 x^3/b^2]_0^b 1/EJ$$

$$= (1/3 b) 1/EJ = 1/3 b/EJ$$

$$L_{EF}^{xo} = \int_0^b (1/2 x/b - 1/2 x^2/b^2) Fb 1/EJ dx + \int_0^b (1) \theta dx = [1/4 x^2/b - 1/6 x^3/b^2]_0^b Fb 1/EJ + [x]_0^b \theta$$

$$= (1/4 b - 1/6 b) Fb 1/EJ + (b) \theta = 13/12 Fb^2/EJ$$

$$L_{FE}^{xo} = \int_0^b (1/2 x/b - 1/2 x^2/b^2) Fb 1/EJ dx + \int_0^b (-1) \theta dx = [1/4 x^2/b - 1/6 x^3/b^2]_0^b Fb 1/EJ + [-x]_0^b \theta$$

$$= (1/4 b - 1/6 b) Fb 1/EJ + (-b) \theta = 13/12 Fb^2/EJ$$

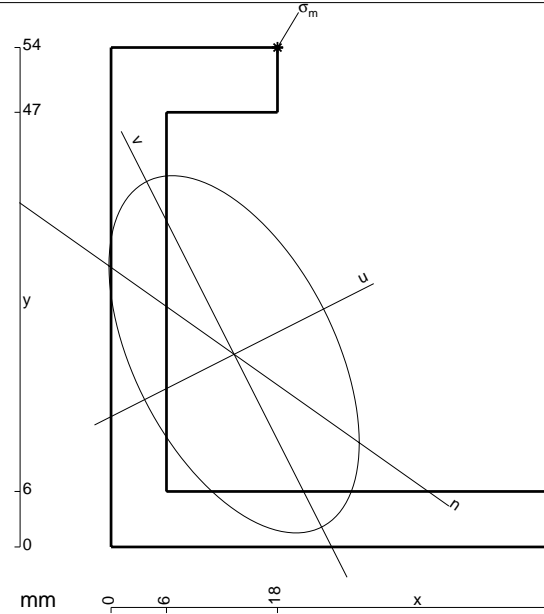

- A = 660. mm²
- J_x = 246224. mm⁴
- J_y = 120837. mm⁴
- J_{xy} = -85387. mm⁴
- J_u = 289462. mm⁴
- J_v = 77600. mm⁴
- α = arctg(2J_{xy}/(J_y-J_x))/2 = .4687
- c = cos α = .8921
- s = sin α = .4518
- x_g = 13.31 mm
- y_g = 20.83 mm
- N = -2290. N
- T_y = -1145. N
- M_x = 1049600. Nmm
- x_m = 18. mm
- y_m = 54. mm
- u_m = 19.17 mm
- v_m = 27.48 mm
- σ_m = N/A - Mcv/J_u - Msu/J_v = -209.5 N/mm²

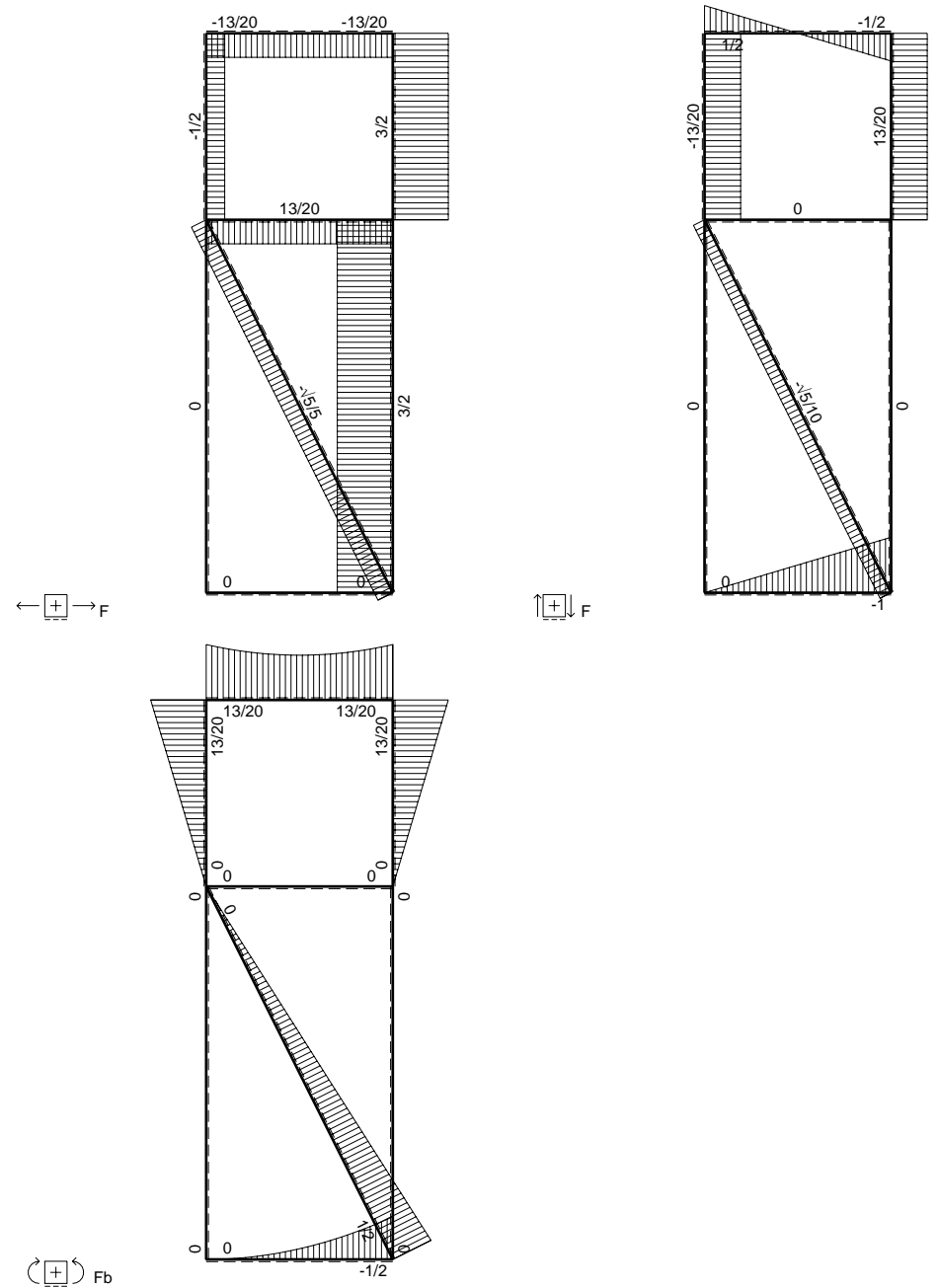
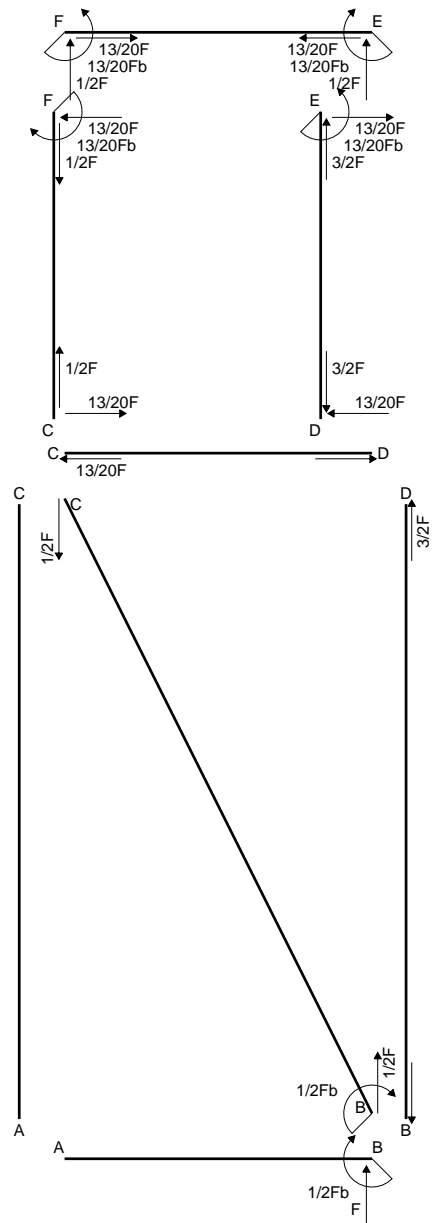

$$L_{DE}^{xx} = \int_0^b (x^2/b^2) 1/EJ dx = [1/3 x^3/b^2]_0^b 1/EJ$$

$$= (1/3 b) 1/EJ = 1/3 b/EJ$$

$$L_{ED}^{xx} = \int_0^b (1 - 2x/b + x^2/b^2) 1/EJ dx = [x - x^2/b + 1/3 x^3/b^2]_0^b 1/EJ$$

$$= (b - b + 1/3 b) 1/EJ = 1/3 b/EJ$$

$$L_{EF}^{xx} = \int_0^b (1) 1/EJ dx = [x]_0^b 1/EJ$$

$$= (b) 1/EJ = b/EJ$$

$$L_{FE}^{xx} = \int_0^b (1) 1/EJ dx = [x]_0^b 1/EJ$$

$$= (b) 1/EJ = b/EJ$$

$$L_{FC}^{xx} = \int_0^b (1 - 2x/b + x^2/b^2) 1/EJ dx = [x - x^2/b + 1/3 x^3/b^2]_0^b 1/EJ$$

$$= (b - b + 1/3 b) 1/EJ = 1/3 b/EJ$$

$$L_{CF}^{xx} = \int_0^b (x^2/b^2) 1/EJ dx = [1/3 x^3/b^2]_0^b 1/EJ$$

$$= (1/3 b) 1/EJ = 1/3 b/EJ$$

$$L_{EF}^{xo} = \int_0^b (1/2 x/b - 1/2 x^2/b^2) Fb 1/EJ dx + \int_0^b (1) \theta dx = [1/4 x^2/b - 1/6 x^3/b^2]_0^b Fb 1/EJ + [x]_0^b \theta$$

$$= (1/4 b - 1/6 b) Fb 1/EJ + (b) \theta = 13/12 Fb^2/EJ$$

$$L_{FE}^{xo} = \int_0^b (1/2 x/b - 1/2 x^2/b^2) Fb 1/EJ dx + \int_0^b (-1) \theta dx = [1/4 x^2/b - 1/6 x^3/b^2]_0^b Fb 1/EJ + [-x]_0^b \theta$$

$$= (1/4 b - 1/6 b) Fb 1/EJ + (-b) \theta = 13/12 Fb^2/EJ$$

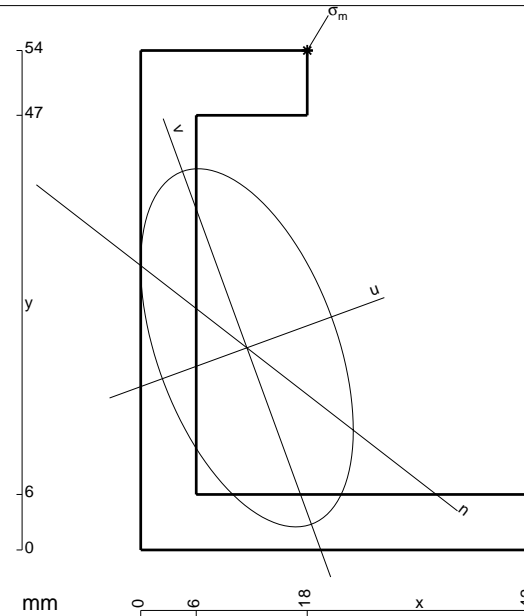

$$A = 624. \text{ mm}^2$$

$$J_x = 234015. \text{ mm}^4$$

$$J_y = 82488. \text{ mm}^4$$

$$J_{xy} = -63875. \text{ mm}^4$$

$$J_u = 257348. \text{ mm}^4$$

$$J_v = 59155. \text{ mm}^4$$

$$\alpha = \text{artg}(2J_{xy}/(J_y - J_x))/2 = .3502$$

$$c = \cos \alpha = .9393$$

$$s = \sin \alpha = .3431$$

$$x_g = 11.48 \text{ mm}$$

$$y_g = 21.86 \text{ mm}$$

$$N = -2379. \text{ N}$$

$$T_y = -1830. \text{ N}$$

$$M_x = 1070550. \text{ Nmm}$$

$$x_m = 18. \text{ mm}$$

$$y_m = 54. \text{ mm}$$

$$u_m = 17.15 \text{ mm}$$

$$v_m = 27.96 \text{ mm}$$

$$\sigma_m = N/A - Mcv/J_u - Msu/J_v = -219.6 \text{ N/mm}^2$$

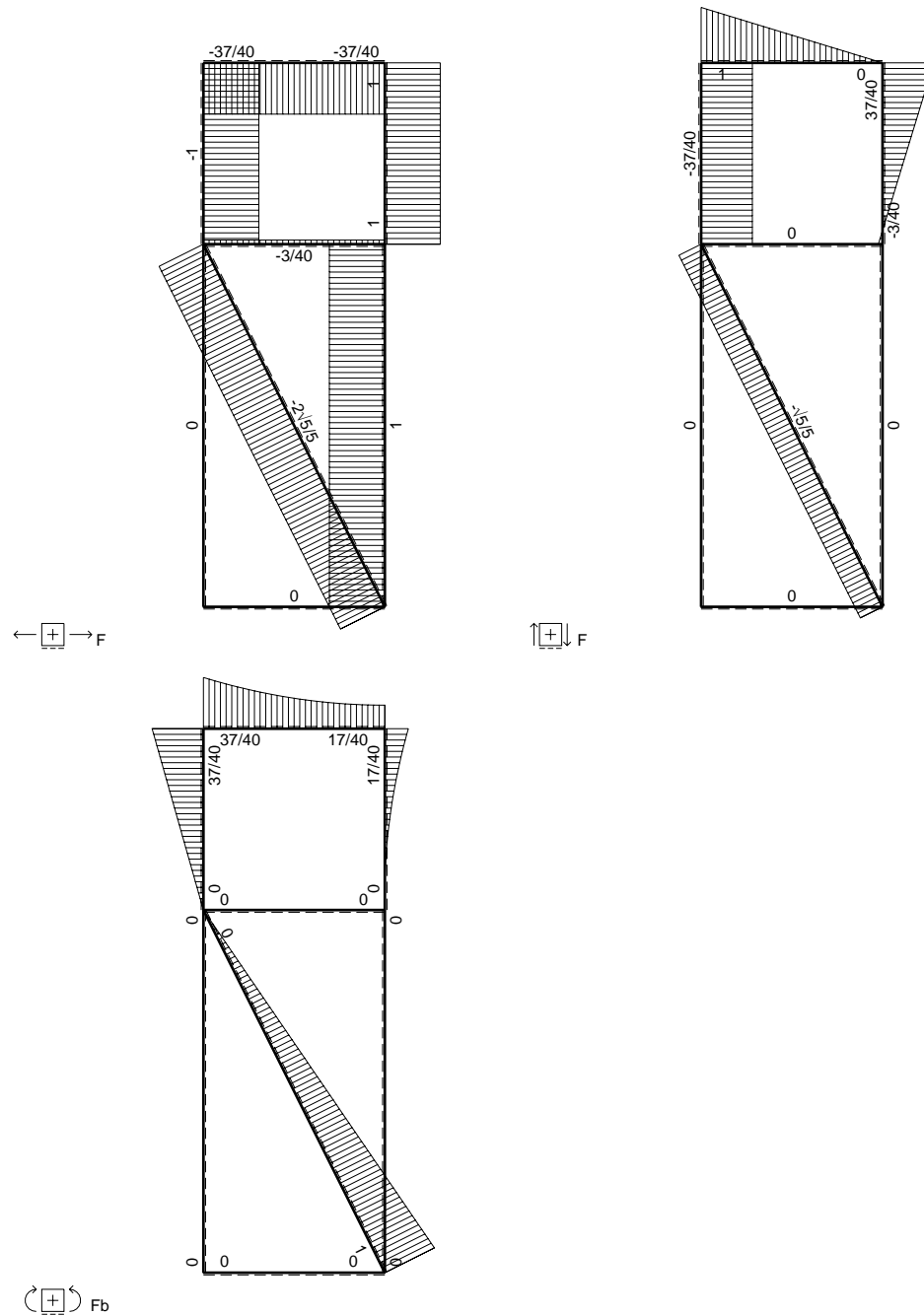
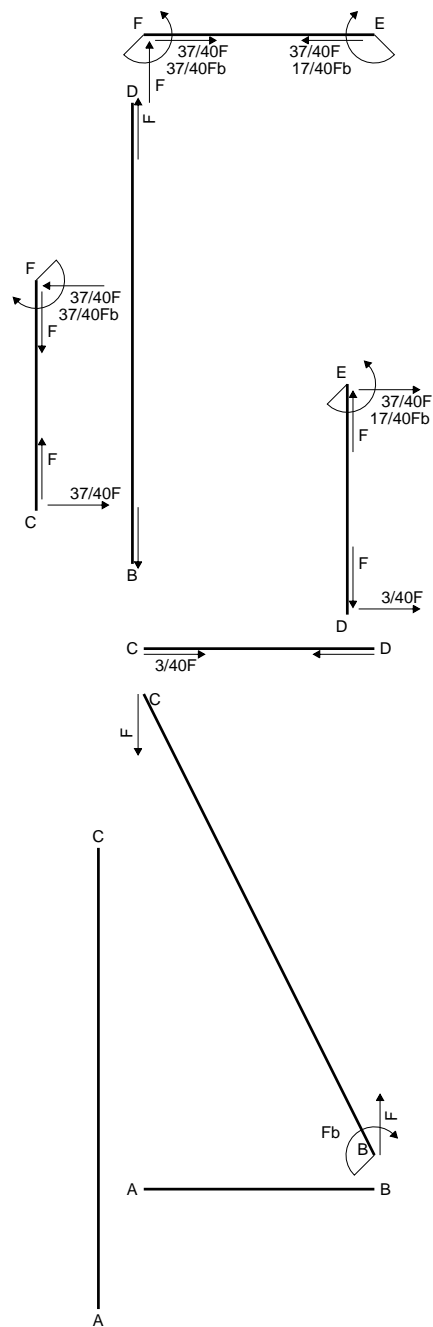

$$L_{DE}^{xx} = \int_0^b (x^2/b^2) 1/EJ dx = [1/3 x^3/b^2]_0^b 1/EJ$$

$$= (1/3 b) 1/EJ = 1/3 b/EJ$$

$$L_{ED}^{xx} = \int_0^b (1 - 2x/b + x^2/b^2) 1/EJ dx = [x - x^2/b + 1/3 x^3/b^2]_0^b 1/EJ$$

$$= (b - b + 1/3 b) 1/EJ = 1/3 b/EJ$$

$$L_{EF}^{xx} = \int_0^b (1) 1/EJ dx = [x]_0^b 1/EJ$$

$$= (b) 1/EJ = b/EJ$$

$$L_{FE}^{xx} = \int_0^b (1) 1/EJ dx = [x]_0^b 1/EJ$$

$$= (b) 1/EJ = b/EJ$$

$$L_{FC}^{xx} = \int_0^b (1 - 2x/b + x^2/b^2) 1/EJ dx = [x - x^2/b + 1/3 x^3/b^2]_0^b 1/EJ$$

$$= (b - b + 1/3 b) 1/EJ = 1/3 b/EJ$$

$$L_{CF}^{xx} = \int_0^b (x^2/b^2) 1/EJ dx = [1/3 x^3/b^2]_0^b 1/EJ$$

$$= (1/3 b) 1/EJ = 1/3 b/EJ$$

$$L_{DE}^{xo} = \int_0^b (1/2 x^2/b^2 - 1/2 x^3/b^3) Fb 1/EJ dx = [1/6 x^3/b^2 - 1/8 x^4/b^3]_0^b Fb 1/EJ$$

$$= (1/6 b - 1/8 b) Fb 1/EJ = 1/24 Fb^2/EJ$$

$$L_{ED}^{xo} = \int_0^b (1/2 x/b - x^2/b^2 + 1/2 x^3/b^3) Fb 1/EJ dx = [1/4 x^2/b - 1/3 x^3/b^2 + 1/8 x^4/b^3]_0^b Fb 1/EJ$$

$$= (1/4 b - 1/3 b + 1/8 b) Fb 1/EJ = 1/24 Fb^2/EJ$$

$$L_{EF}^{xo} = \int_0^b (-1/2 x^2/b^2) Fb 1/EJ dx + \int_0^b (1) \theta dx = [-1/6 x^3/b^2]_0^b Fb 1/EJ + [x]_0^b \theta$$

$$= (-1/6 b) Fb 1/EJ + (b) \theta = 5/6 Fb^2/EJ$$

$$L_{FE}^{xo} = \int_0^b (-1/2 + x/b - 1/2 x^2/b^2) Fb 1/EJ dx + \int_0^b (-1) \theta dx$$

$$= [-1/2 x + 1/2 x^2/b - 1/6 x^3/b^2]_0^b Fb 1/EJ + [-x]_0^b \theta$$

$$= (-1/2 b + 1/2 b - 1/6 b) Fb 1/EJ + (-b) \theta = 5/6 Fb^2/EJ$$

$$L_{FC}^{xo} = \int_0^b (-1/2 + x/b - 1/2 x^2/b^2) Fb 1/EJ dx = [-1/2 x + 1/2 x^2/b - 1/6 x^3/b^2]_0^b Fb 1/EJ$$

$$= (-1/2 b + 1/2 b - 1/6 b) Fb 1/EJ = -1/6 Fb^2/EJ$$

$$L_{CF}^{xo} = \int_0^b (-1/2 x^2/b^2) Fb 1/EJ dx = [-1/6 x^3/b^2]_0^b Fb 1/EJ$$

$$= (-1/6 b) Fb 1/EJ = -1/6 Fb^2/EJ$$

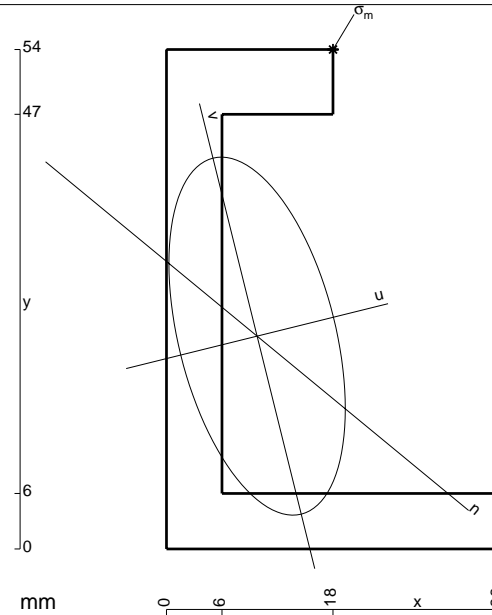

- A = 588. mm²
- J_x = 220324. mm⁴
- J_y = 53448. mm⁴
- J_{xy} = -44051. mm⁴
- J_u = 231238. mm⁴
- J_v = 42533. mm⁴
- α = arctg(2J_{xy}/(J_y-J_x))/2 = .2429
- c = cos α = .9707
- s = sin α = .2405
- x_g = 9.796 mm
- y_g = 23.01 mm
- N = -2012. N
- T_y = -1006. N
- M_x = 1102500. Nmm
- x_m = 18. mm
- y_m = 54. mm
- u_m = 15.42 mm
- v_m = 28.11 mm
- σ_m = N/A - Mc_v/J_u - Ms_u/J_v = -229.6 N/mm²

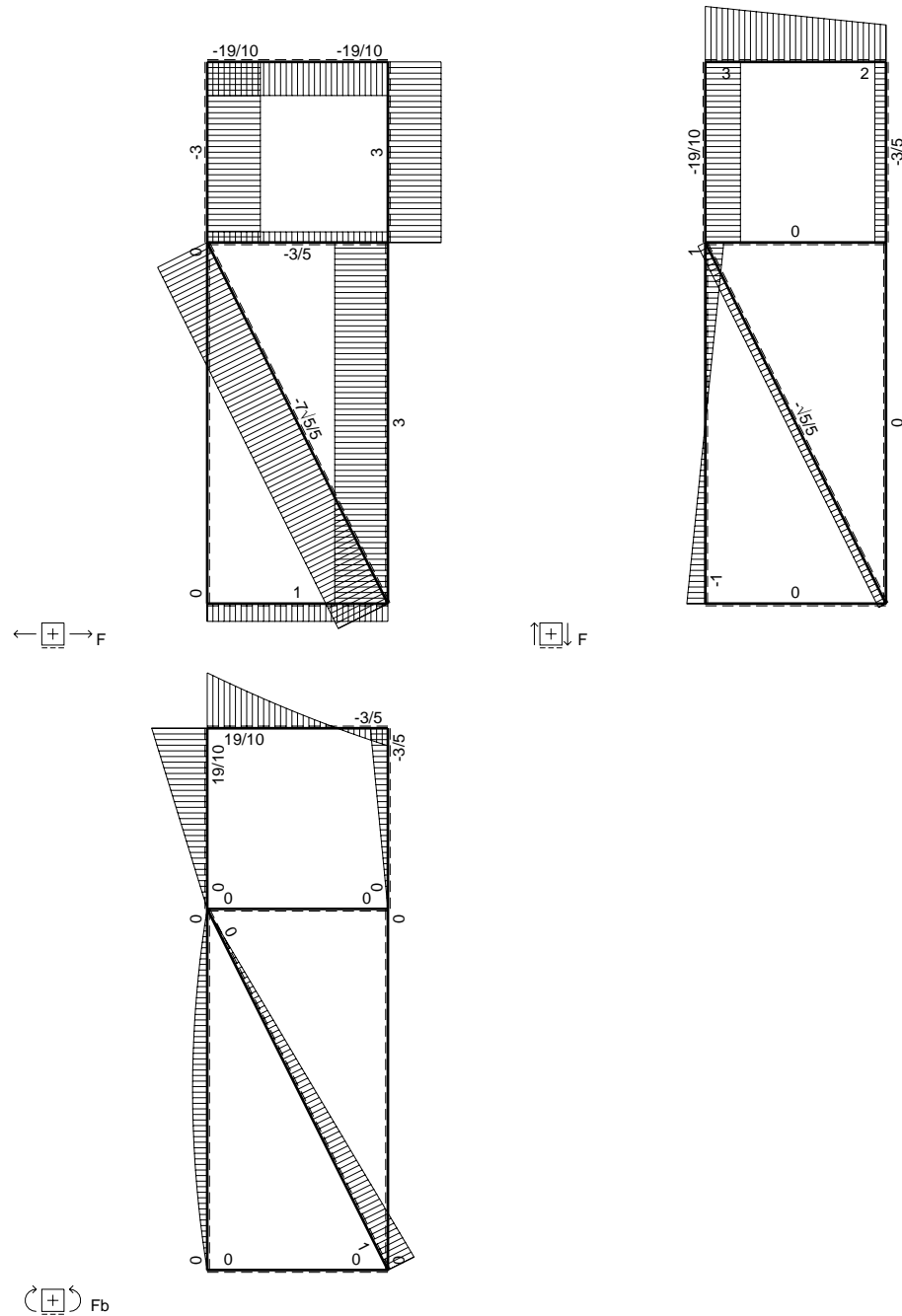
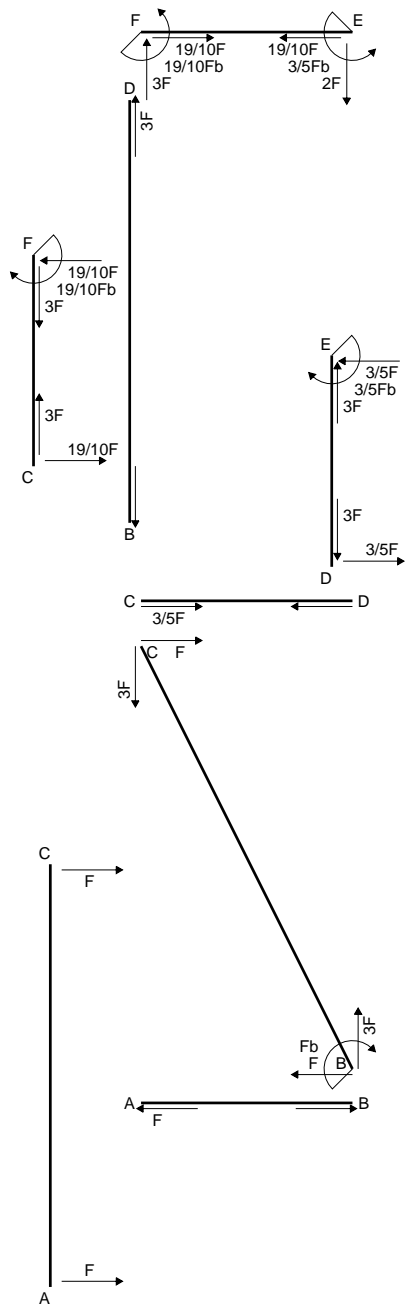

\oplus F_b

$$L_{DE}^{xx} = \int_0^b (x^2/b^2) 1/EJ dx = [1/3 x^3/b^2]_0^b 1/EJ$$

$$= (1/3 b) 1/EJ = 1/3 b/EJ$$

$$L_{ED}^{xx} = \int_0^b (1 - 2x/b + x^2/b^2) 1/EJ dx = [x - x^2/b + 1/3 x^3/b^2]_0^b 1/EJ$$

$$= (b - b + 1/3 b) 1/EJ = 1/3 b/EJ$$

$$L_{EF}^{xx} = \int_0^b (1) 1/EJ dx = [x]_0^b 1/EJ$$

$$= (b) 1/EJ = b/EJ$$

$$L_{FE}^{xx} = \int_0^b (1) 1/EJ dx = [x]_0^b 1/EJ$$

$$= (b) 1/EJ = b/EJ$$

$$L_{FC}^{xx} = \int_0^b (1 - 2x/b + x^2/b^2) 1/EJ dx = [x - x^2/b + 1/3 x^3/b^2]_0^b 1/EJ$$

$$= (b - b + 1/3 b) 1/EJ = 1/3 b/EJ$$

$$L_{CF}^{xx} = \int_0^b (x^2/b^2) 1/EJ dx = [1/3 x^3/b^2]_0^b 1/EJ$$

$$= (1/3 b) 1/EJ = 1/3 b/EJ$$

$$L_{EF}^{xo} = \int_0^b (-2x/b - 1/2 x^2/b^2) Fb 1/EJ dx + \int_0^b (1) \theta dx = [-x^2/b - 1/6 x^3/b^2]_0^b Fb 1/EJ + [x]_0^b \theta$$

$$= (-b - 1/6 b) Fb 1/EJ + (b) \theta = -1/6 Fb^2/EJ$$

$$L_{FE}^{xo} = \int_0^b (-5/2 + 3x/b - 1/2 x^2/b^2) Fb 1/EJ dx + \int_0^b (-1) \theta dx$$

$$= [-5/2 x + 3/2 x^2/b - 1/6 x^3/b^2]_0^b Fb 1/EJ + [-x]_0^b \theta$$

$$= (-5/2 b + 3/2 b - 1/6 b) Fb 1/EJ + (-b) \theta = -1/6 Fb^2/EJ$$

$$L_{FC}^{xo} = \int_0^b (-5/2 + 5x/b - 5/2 x^2/b^2) Fb 1/EJ dx = [-5/2 x + 5/2 x^2/b - 5/6 x^3/b^2]_0^b Fb 1/EJ$$

$$= (-5/2 b + 5/2 b - 5/6 b) Fb 1/EJ = -5/6 Fb^2/EJ$$

$$L_{CF}^{xo} = \int_0^b (-5/2 x^2/b^2) Fb 1/EJ dx = [-5/6 x^3/b^2]_0^b Fb 1/EJ$$

$$= (-5/6 b) Fb 1/EJ = -5/6 Fb^2/EJ$$

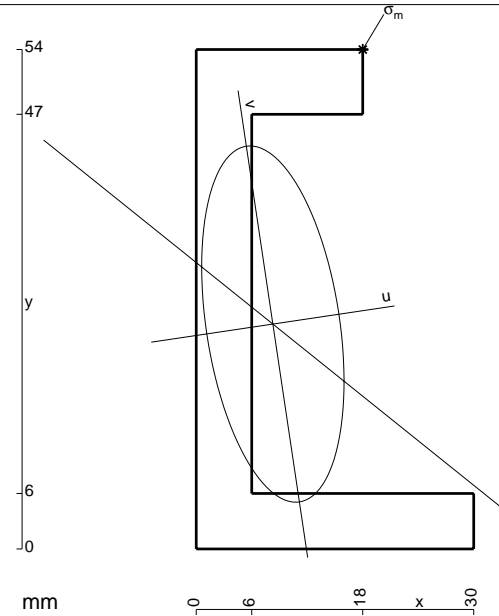

$$A = 552. \text{ mm}^2$$

$$J_x = 204861. \text{ mm}^4$$

$$J_y = 32692. \text{ mm}^4$$

$$J_{xy} = -26245. \text{ mm}^4$$

$$J_u = 208773. \text{ mm}^4$$

$$J_v = 28780. \text{ mm}^4$$

$$\alpha = \text{artg}(2J_{xy}/(J_y - J_x))/2 = .1480$$

$$c = \cos \alpha = .9891$$

$$s = \sin \alpha = .1474$$

$$x_g = 8.283 \text{ mm}$$

$$y_g = 24.32 \text{ mm}$$

$$N = -3390. \text{ N}$$

$$T_y = -2147. \text{ N}$$

$$M_x = 1137910. \text{ Nmm}$$

$$x_m = 18. \text{ mm}$$

$$y_m = 54. \text{ mm}$$

$$u_m = 13.99 \text{ mm}$$

$$v_m = 27.93 \text{ mm}$$

$$\sigma_m = N/A - Mcv/J_u - Msu/J_v = -238.2 \text{ N/mm}^2$$

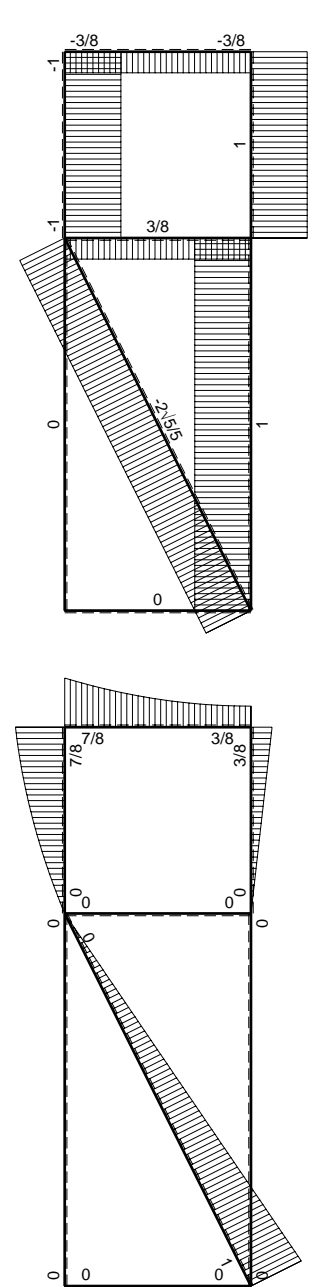
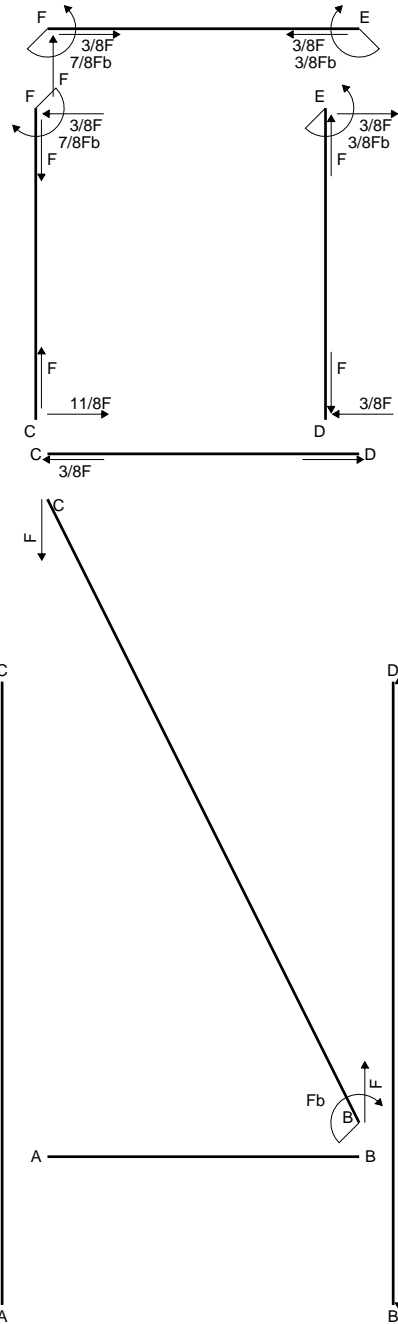

← ⊕ → F

↑ ⊕ ↓ F

⊕ ⊖ Fb

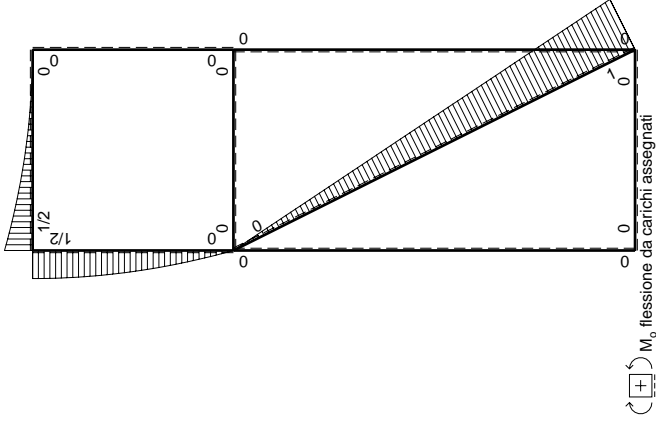
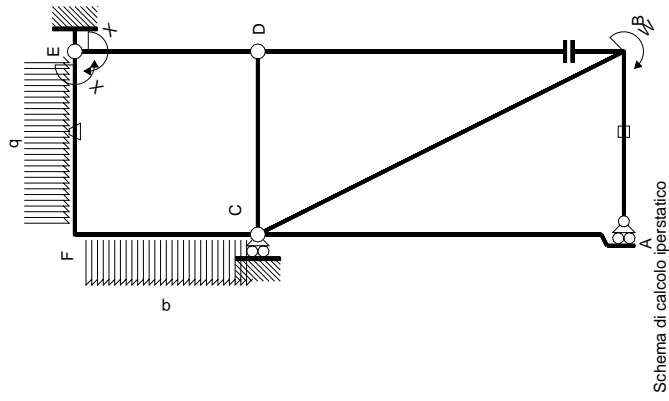

Quadro contributi PLV per iperstatica X=W^{EF}

←	M _x (x)	M ₀ (x)	θ	M _x θ	M _x M ₀	∫ M _x (M ₀ /EJ+θ)dx	∫ M _x M ₀ /EJdx
AB	0	0	0	0	0	0	0
BA	0	0	0	0	0	0	0
BC	0	Fb-√5/5Fx	0	0	0	0	0
AC	0	0	0	0	0	0	0
CA	0	0	0	0	0	0	0
DB	0	0	0	0	0	0	0
BD	0	0	0	0	0	0	0
DE	-x/b	0	0	0	0	x ² /b ²	1/3Xb/EJ
ED	1-x/b	0	0	0	0	1-2x/b+x ² /b ²	1/3Xb/EJ
CD	0	0	0	0	0	0	0
DC	0	0	0	0	0	0	0
EF	-1	1/2qx ²	-Fb/EJ	-1/2Fx ² /b	Fb/EJ	1	Xb/EJ
FE	1	-1/2Fb+Fx-1/2qx ²	Fb/EJ	-1/2Fx ² /b	Fb/EJ	1	Xb/EJ
FC	-1+x/b	1/2Fb-1/2qx ²	0	-1/2Fb+1/2Fx+1/2Fx ² /b-1/2qx ³ /b	0	1-2x/b+x ² /b ²	(-5/24+0)Fb ² /EJ
CF	x/b	-Fx+1/2qx ²	0	-Fx ² /b+1/2qx ³ /b	0	x ² /b ²	1/3Xb/EJ
totali							
							5/8Fb ² /EJ
							-3/8Fb

Sviluppi di calcolo iperstatica

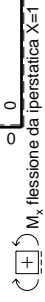

$$L_{DE}^{xx} = \int_0^b (x^2/b^2) 1/EJ dx = [1/3 x^3/b^2]_0^b 1/EJ$$

$$= (1/3 b) 1/EJ = 1/3 b/EJ$$

$$L_{ED}^{xx} = \int_0^b (1 - 2x/b + x^2/b^2) 1/EJ dx = [x - x^2/b + 1/3 x^3/b^2]_0^b 1/EJ$$

$$= (b - b + 1/3 b) 1/EJ = 1/3 b/EJ$$

$$L_{EF}^{xx} = \int_0^b (1) 1/EJ dx = [x]_0^b 1/EJ$$

$$= (b) 1/EJ = b/EJ$$

$$L_{FE}^{xx} = \int_0^b (1) 1/EJ dx = [x]_0^b 1/EJ$$

$$= (b) 1/EJ = b/EJ$$

$$L_{FC}^{xx} = \int_0^b (1 - 2x/b + x^2/b^2) 1/EJ dx = [x - x^2/b + 1/3 x^3/b^2]_0^b 1/EJ$$

$$= (b - b + 1/3 b) 1/EJ = 1/3 b/EJ$$

$$L_{CF}^{xx} = \int_0^b (x^2/b^2) 1/EJ dx = [1/3 x^3/b^2]_0^b 1/EJ$$

$$= (1/3 b) 1/EJ = 1/3 b/EJ$$

$$L_{EF}^{xo} = \int_0^b (-1/2 x^2/b^2) Fb 1/EJ dx + \int_0^b (1) \theta dx = [-1/6 x^3/b^2]_0^b Fb 1/EJ + [x]_0^b \theta$$

$$= (-1/6 b) Fb 1/EJ + (b) \theta = 5/6 Fb^2/EJ$$

$$L_{FE}^{xo} = \int_0^b (-1/2 + x/b - 1/2 x^2/b^2) Fb 1/EJ dx + \int_0^b (-1) \theta dx$$

$$= [-1/2 x + 1/2 x^2/b - 1/6 x^3/b^2]_0^b Fb 1/EJ + [-x]_0^b \theta$$

$$= (-1/2 b + 1/2 b - 1/6 b) Fb 1/EJ + (-b) \theta = 5/6 Fb^2/EJ$$

$$L_{FC}^{xo} = \int_0^b (-1/2 + 1/2 x/b + 1/2 x^2/b^2 - 1/2 x^3/b^3) Fb 1/EJ dx$$

$$= [-1/2 x + 1/4 x^2/b + 1/6 x^3/b^2 - 1/8 x^4/b^3]_0^b Fb 1/EJ$$

$$= (-1/2 b + 1/4 b + 1/6 b - 1/8 b) Fb 1/EJ = -5/24 Fb^2/EJ$$

$$L_{CF}^{xo} = \int_0^b (-x^2/b^2 + 1/2 x^3/b^3) Fb 1/EJ dx = [-1/3 x^3/b^2 + 1/8 x^4/b^3]_0^b Fb 1/EJ$$

$$= (-1/3 b + 1/8 b) Fb 1/EJ = -5/24 Fb^2/EJ$$

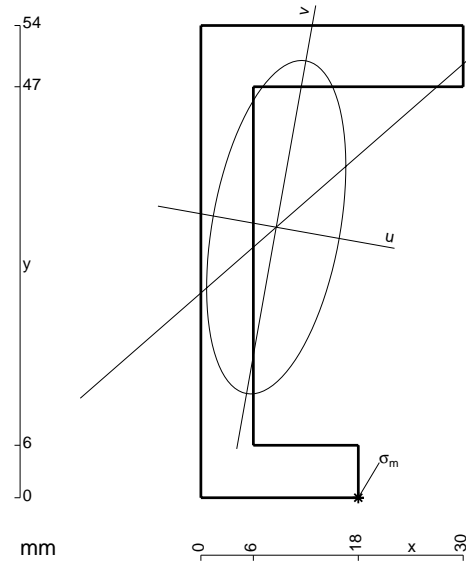

- A = 564. mm²
- J_x = 205146. mm⁴
- J_y = 35737. mm⁴
- J_{xy} = 31198. mm⁴
- J_u = 210708. mm⁴
- J_v = 30175. mm⁴
- α = arctg(2J_{xy}/(J_y-J_x))/2 = -.1764
- c = cos α = .9845
- s = sin α = -.1755
- x_g = 8.617 mm
- y_g = 30.94 mm
- N = -1440. N
- T_y = -720. N
- M_x = 917700. Nmm
- x_m = 18. mm
- u_m = 14.67 mm
- v_m = -28.81 mm
- σ_m = N/A - Mcv/J_u - Msu/J_v = 199.3 N/mm²

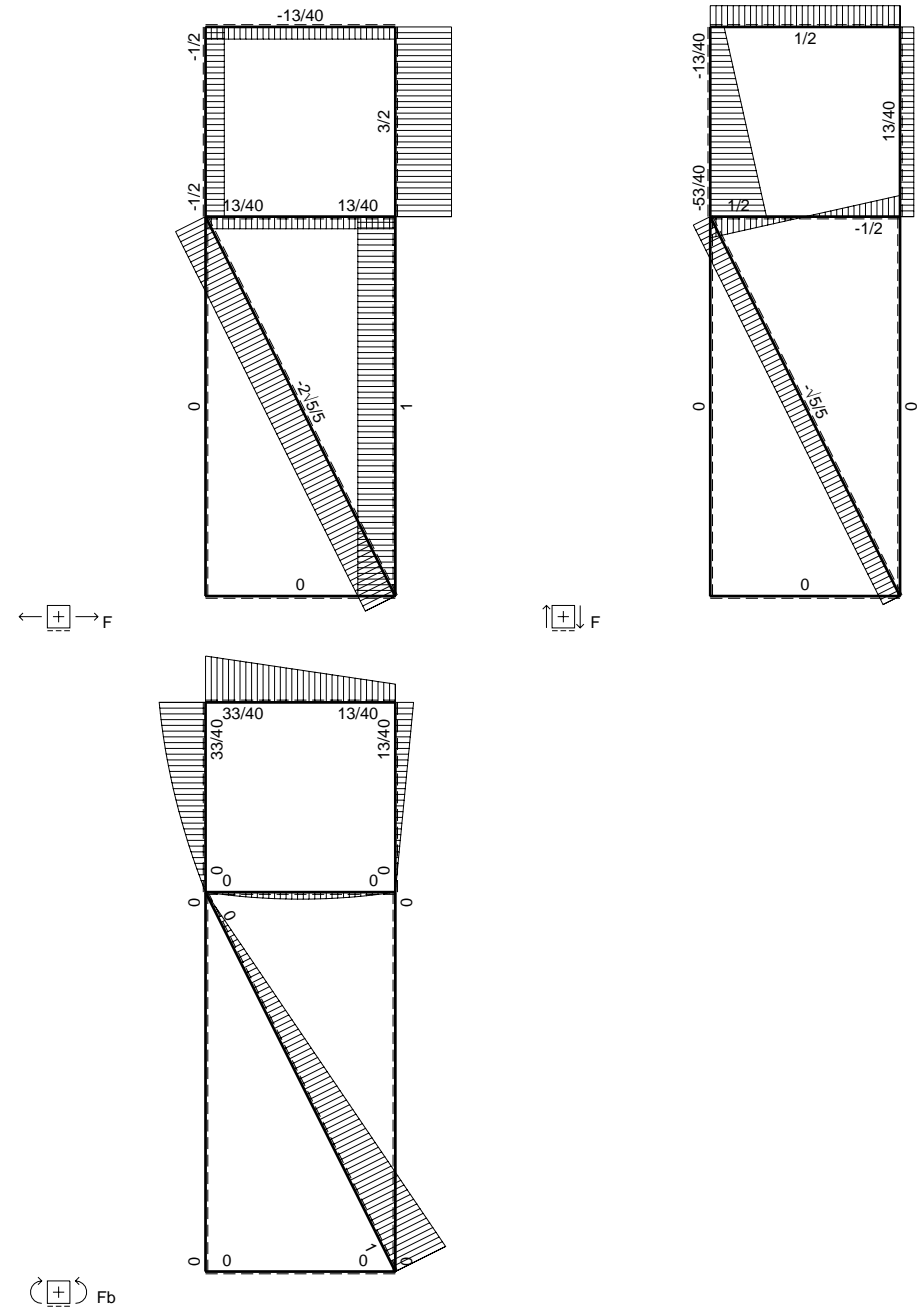
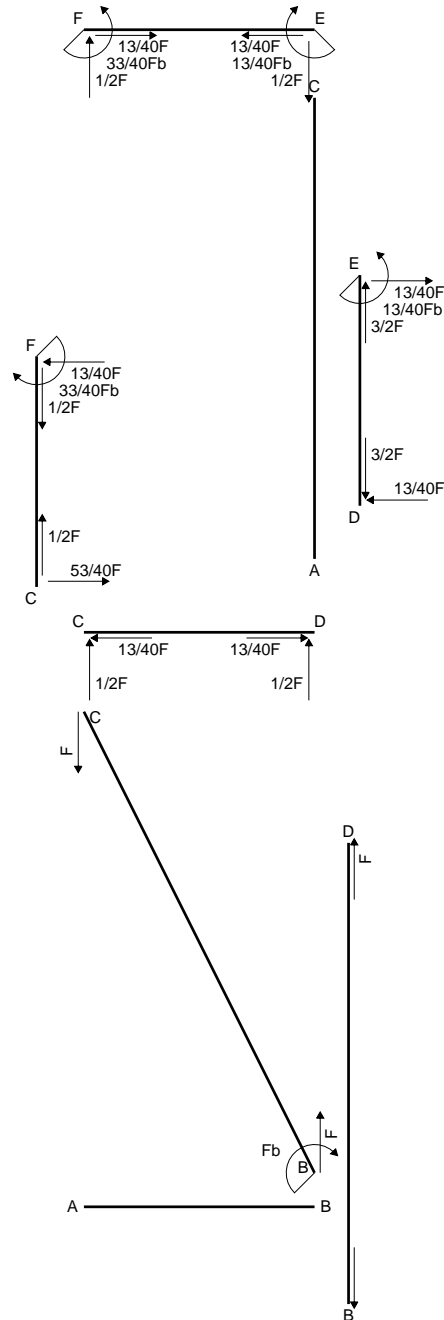

$$L_{DE}^{xx} = \int_0^b (x^2/b^2) 1/EJ dx = [1/3 x^3/b^2]_0^b 1/EJ$$

$$= (1/3 b) 1/EJ = 1/3 b/EJ$$

$$L_{ED}^{xx} = \int_0^b (1 - 2x/b + x^2/b^2) 1/EJ dx = [x - x^2/b + 1/3 x^3/b^2]_0^b 1/EJ$$

$$= (b - b + 1/3 b) 1/EJ = 1/3 b/EJ$$

$$L_{EF}^{xx} = \int_0^b (1) 1/EJ dx = [x]_0^b 1/EJ$$

$$= (b) 1/EJ = b/EJ$$

$$L_{FE}^{xx} = \int_0^b (1) 1/EJ dx = [x]_0^b 1/EJ$$

$$= (b) 1/EJ = b/EJ$$

$$L_{FC}^{xx} = \int_0^b (1 - 2x/b + x^2/b^2) 1/EJ dx = [x - x^2/b + 1/3 x^3/b^2]_0^b 1/EJ$$

$$= (b - b + 1/3 b) 1/EJ = 1/3 b/EJ$$

$$L_{CF}^{xx} = \int_0^b (x^2/b^2) 1/EJ dx = [1/3 x^3/b^2]_0^b 1/EJ$$

$$= (1/3 b) 1/EJ = 1/3 b/EJ$$

$$L_{EF}^{xo} = \int_0^b (-1/2 x/b) Fb 1/EJ dx + \int_0^b (1) \theta dx = [-1/4 x^2/b]_0^b Fb 1/EJ + [x]_0^b \theta$$

$$= (-1/4 b) Fb 1/EJ + (b) \theta = 3/4 Fb^2/EJ$$

$$L_{FE}^{xo} = \int_0^b (-1/2 + 1/2 x/b) Fb 1/EJ dx + \int_0^b (-1) \theta dx = [-1/2 x + 1/4 x^2/b]_0^b Fb 1/EJ + [-x]_0^b \theta$$

$$= (-1/2 b + 1/4 b) Fb 1/EJ + (-b) \theta = 3/4 Fb^2/EJ$$

$$L_{FC}^{xo} = \int_0^b (-1/2 + 1/2 x/b + 1/2 x^2/b^2 - 1/2 x^3/b^3) Fb 1/EJ dx$$

$$= [-1/2 x + 1/4 x^2/b + 1/6 x^3/b^2 - 1/8 x^4/b^3]_0^b Fb 1/EJ$$

$$= (-1/2 b + 1/4 b + 1/6 b - 1/8 b) Fb 1/EJ = -5/24 Fb^2/EJ$$

$$L_{CF}^{xo} = \int_0^b (-x^2/b^2 + 1/2 x^3/b^3) Fb 1/EJ dx = [-1/3 x^3/b^2 + 1/8 x^4/b^3]_0^b Fb 1/EJ$$

$$= (-1/3 b + 1/8 b) Fb 1/EJ = -5/24 Fb^2/EJ$$

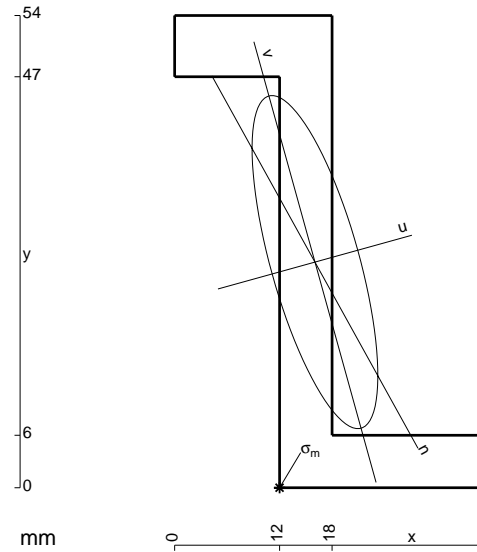

$A = 516. \text{ mm}^2$
 $J_x = 187256. \text{ mm}^4$
 $J_y = 26687. \text{ mm}^4$
 $J_{xy} = -48223. \text{ mm}^4$
 $J_u = 200625. \text{ mm}^4$
 $J_v = 13317. \text{ mm}^4$
 $\alpha = \text{artg}(2J_{xy}/(J_y - J_x))/2 = .2704$
 $c = \cos \alpha = .9637$
 $s = \sin \alpha = .2672$
 $x_g = 16.05 \text{ mm}$
 $y_g = 25.8 \text{ mm}$
 $N = -948.1 \text{ N}$
 $T_y = -474. \text{ N}$
 $M_x = 636000. \text{ Nmm}$
 $x_m = 12. \text{ mm}$
 $u_m = -10.79 \text{ mm}$
 $v_m = -23.78 \text{ mm}$
 $\sigma_m = N/A - Mcv/J_u - Msu/J_v = 208.5 \text{ N/mm}^2$

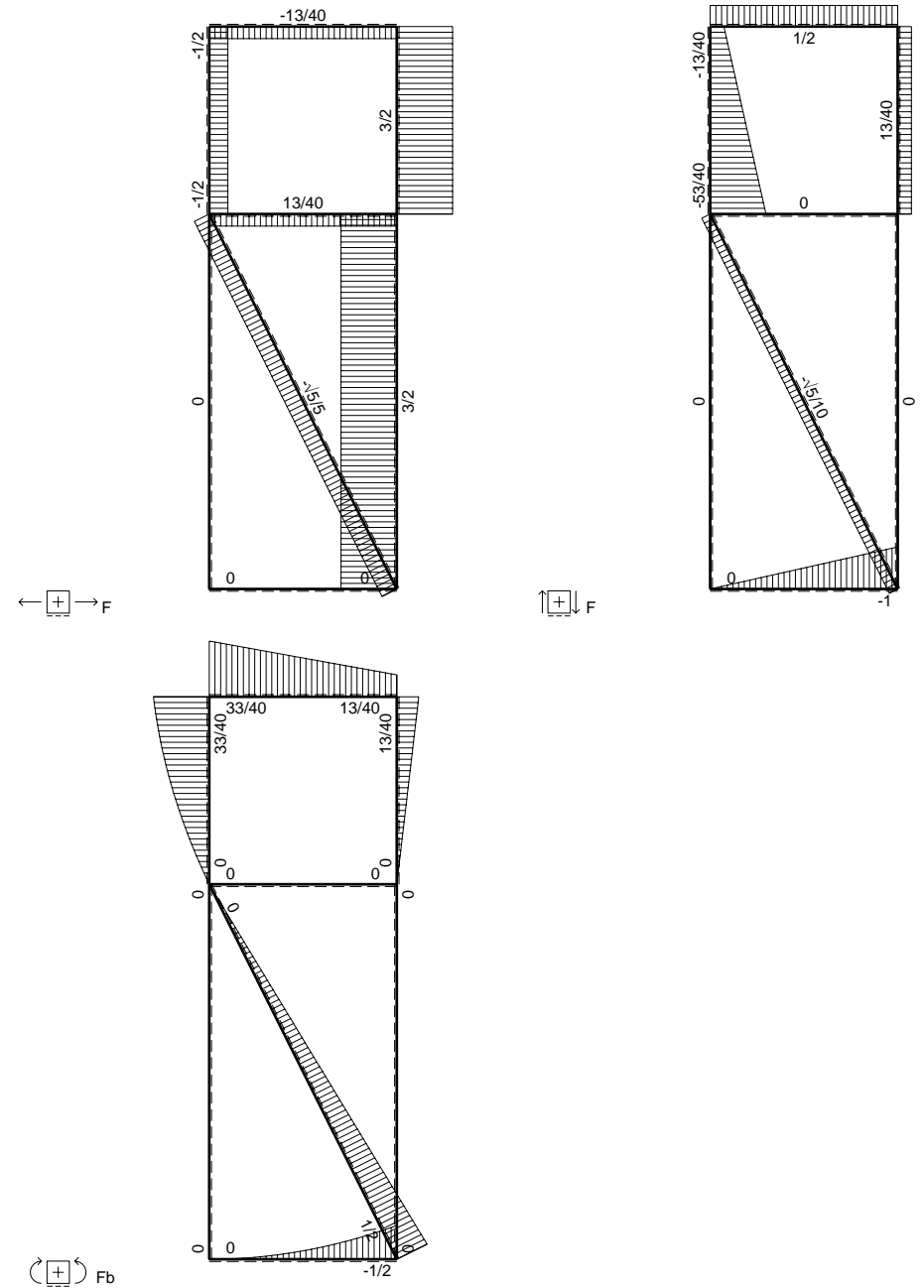
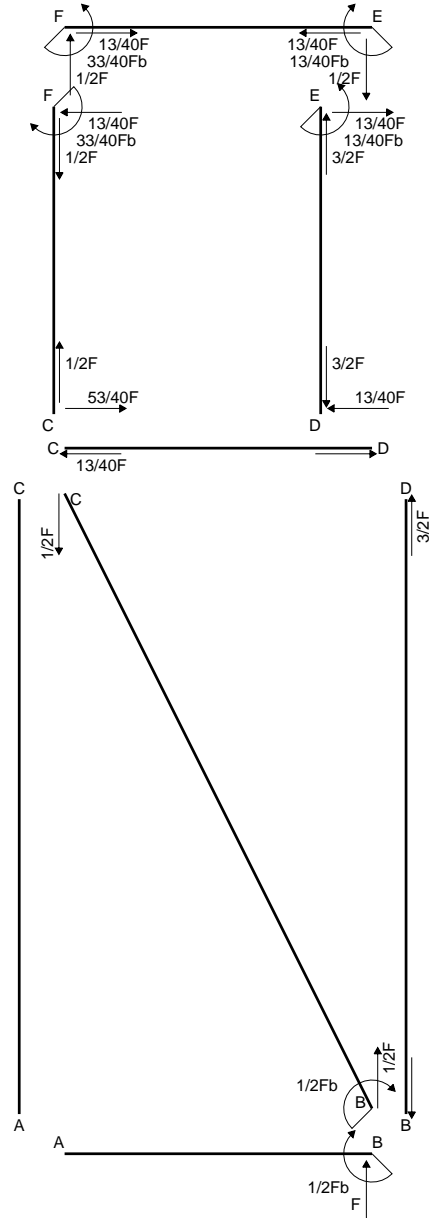

$$L_{DE}^{xx} = \int_0^b (x^2/b^2) 1/EJ dx = [1/3 x^3/b^2]_0^b 1/EJ$$

$$= (1/3 b) 1/EJ = 1/3 b/EJ$$

$$L_{ED}^{xx} = \int_0^b (1 - 2x/b + x^2/b^2) 1/EJ dx = [x - x^2/b + 1/3 x^3/b^2]_0^b 1/EJ$$

$$= (b - b + 1/3 b) 1/EJ = 1/3 b/EJ$$

$$L_{EF}^{xx} = \int_0^b (1) 1/EJ dx = [x]_0^b 1/EJ$$

$$= (b) 1/EJ = b/EJ$$

$$L_{FE}^{xx} = \int_0^b (1) 1/EJ dx = [x]_0^b 1/EJ$$

$$= (b) 1/EJ = b/EJ$$

$$L_{FC}^{xx} = \int_0^b (1 - 2x/b + x^2/b^2) 1/EJ dx = [x - x^2/b + 1/3 x^3/b^2]_0^b 1/EJ$$

$$= (b - b + 1/3 b) 1/EJ = 1/3 b/EJ$$

$$L_{CF}^{xx} = \int_0^b (x^2/b^2) 1/EJ dx = [1/3 x^3/b^2]_0^b 1/EJ$$

$$= (1/3 b) 1/EJ = 1/3 b/EJ$$

$$L_{EF}^{xo} = \int_0^b (-1/2 x/b) Fb 1/EJ dx + \int_0^b (1) \theta dx = [-1/4 x^2/b]_0^b Fb 1/EJ + [x]_0^b \theta$$

$$= (-1/4 b) Fb 1/EJ + (b) \theta = 3/4 Fb^2/EJ$$

$$L_{FE}^{xo} = \int_0^b (-1/2 + 1/2 x/b) Fb 1/EJ dx + \int_0^b (-1) \theta dx = [-1/2 x + 1/4 x^2/b]_0^b Fb 1/EJ + [-x]_0^b \theta$$

$$= (-1/2 b + 1/4 b) Fb 1/EJ + (-b) \theta = 3/4 Fb^2/EJ$$

$$L_{FC}^{xo} = \int_0^b (-1/2 + 1/2 x/b + 1/2 x^2/b^2 - 1/2 x^3/b^3) Fb 1/EJ dx$$

$$= [-1/2 x + 1/4 x^2/b + 1/6 x^3/b^2 - 1/8 x^4/b^3]_0^b Fb 1/EJ$$

$$= (-1/2 b + 1/4 b + 1/6 b - 1/8 b) Fb 1/EJ = -5/24 Fb^2/EJ$$

$$L_{CF}^{xo} = \int_0^b (-x^2/b^2 + 1/2 x^3/b^3) Fb 1/EJ dx = [-1/3 x^3/b^2 + 1/8 x^4/b^3]_0^b Fb 1/EJ$$

$$= (-1/3 b + 1/8 b) Fb 1/EJ = -5/24 Fb^2/EJ$$

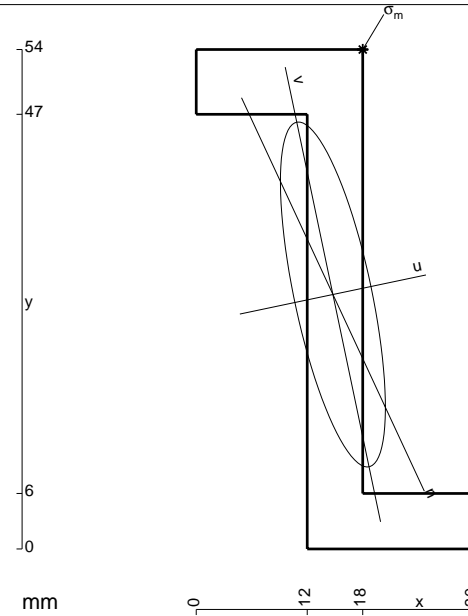

- A = 480. mm²
- J_x = 167026. mm⁴
- J_y = 15456. mm⁴
- J_{xy} = -33263. mm⁴
- J_u = 174004. mm⁴
- J_v = 8477. mm⁴
- α = arctg(2J_{xy}/(J_y-J_x))/2 = .2068
- c = cos α = .9787
- s = sin α = .2053
- x_g = 14.77 mm
- y_g = 27.51 mm
- N = -590. N
- T_y = -383.5 N
- M_x = 623040. Nmm
- x_m = 18. mm
- y_m = 54. mm
- u_m = 8.595 mm
- v_m = 25.26 mm
- σ_m = N/A - Mcv/J_u - Msu/J_v = -219.4 N/mm²

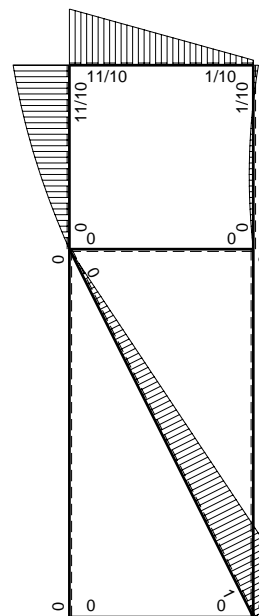
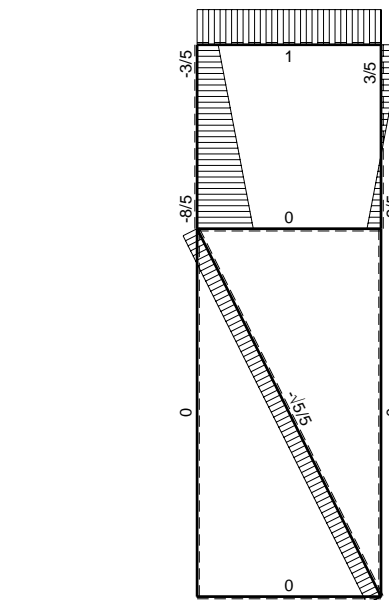
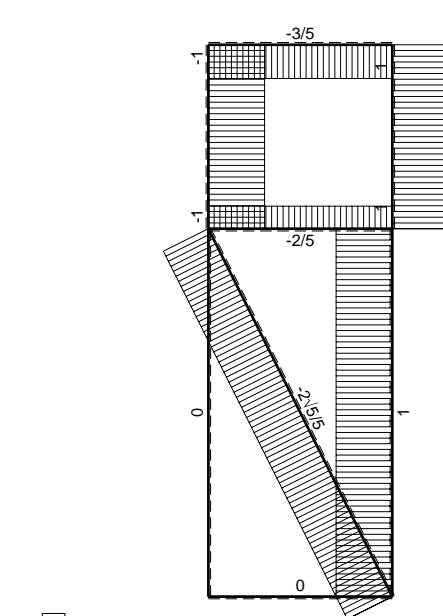
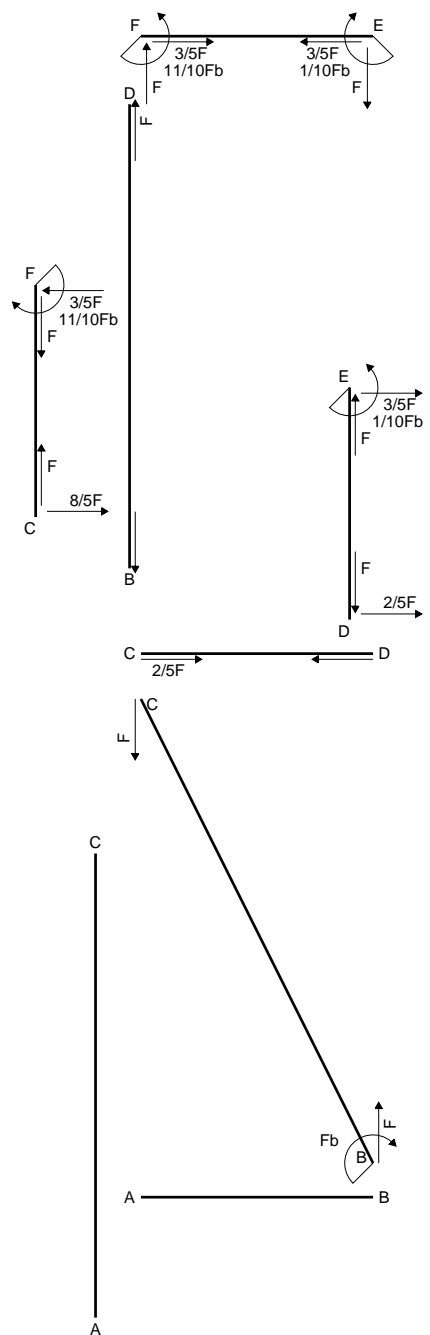

$$L_{DE}^{xx} = \int_0^b (x^2/b^2) 1/EJ dx = [1/3 x^3/b^2]_0^b 1/EJ$$

$$= (1/3 b) 1/EJ = 1/3 b/EJ$$

$$L_{ED}^{xx} = \int_0^b (1 - 2x/b + x^2/b^2) 1/EJ dx = [x - x^2/b + 1/3 x^3/b^2]_0^b 1/EJ$$

$$= (b - b + 1/3 b) 1/EJ = 1/3 b/EJ$$

$$L_{EF}^{xx} = \int_0^b (1) 1/EJ dx = [x]_0^b 1/EJ$$

$$= (b) 1/EJ = b/EJ$$

$$L_{FE}^{xx} = \int_0^b (1) 1/EJ dx = [x]_0^b 1/EJ$$

$$= (b) 1/EJ = b/EJ$$

$$L_{FC}^{xx} = \int_0^b (1 - 2x/b + x^2/b^2) 1/EJ dx = [x - x^2/b + 1/3 x^3/b^2]_0^b 1/EJ$$

$$= (b - b + 1/3 b) 1/EJ = 1/3 b/EJ$$

$$L_{CF}^{xx} = \int_0^b (x^2/b^2) 1/EJ dx = [1/3 x^3/b^2]_0^b 1/EJ$$

$$= (1/3 b) 1/EJ = 1/3 b/EJ$$

$$L_{DE}^{xo} = \int_0^b (1/2 x^2/b^2 - 1/2 x^3/b^3) Fb 1/EJ dx = [1/6 x^3/b^2 - 1/8 x^4/b^3]_0^b Fb 1/EJ$$

$$= (1/6 b - 1/8 b) Fb 1/EJ = 1/24 Fb^2/EJ$$

$$L_{ED}^{xo} = \int_0^b (1/2 x/b - x^2/b^2 + 1/2 x^3/b^3) Fb 1/EJ dx = [1/4 x^2/b - 1/3 x^3/b^2 + 1/8 x^4/b^3]_0^b Fb 1/EJ$$

$$= (1/4 b - 1/3 b + 1/8 b) Fb 1/EJ = 1/24 Fb^2/EJ$$

$$L_{EF}^{xo} = \int_0^b (-x/b) Fb 1/EJ dx + \int_0^b (1) \theta dx = [-1/2 x^2/b]_0^b Fb 1/EJ + [x]_0^b \theta$$

$$= (-1/2 b) Fb 1/EJ + (b) \theta = 1/2 Fb^2/EJ$$

$$L_{FE}^{xo} = \int_0^b (-1 + x/b) Fb 1/EJ dx + \int_0^b (-1) \theta dx = [-x + 1/2 x^2/b]_0^b Fb 1/EJ + [-x]_0^b \theta$$

$$= (-b + 1/2 b) Fb 1/EJ + (-b) \theta = 1/2 Fb^2/EJ$$

$$L_{FC}^{xo} = \int_0^b (-1 + 3/2 x/b - 1/2 x^3/b^3) Fb 1/EJ dx = [-x + 3/4 x^2/b - 1/8 x^4/b^3]_0^b Fb 1/EJ$$

$$= (-b + 3/4 b - 1/8 b) Fb 1/EJ = -3/8 Fb^2/EJ$$

$$L_{CF}^{xo} = \int_0^b (-3/2 x^2/b^2 + 1/2 x^3/b^3) Fb 1/EJ dx = [-1/2 x^3/b^2 + 1/8 x^4/b^3]_0^b Fb 1/EJ$$

$$= (-1/2 b + 1/8 b) Fb 1/EJ = -3/8 Fb^2/EJ$$

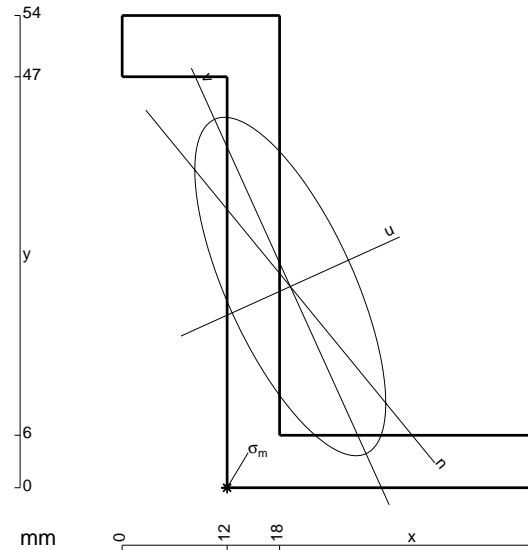

- A = 588. mm²
- J_x = 220324. mm⁴
- J_y = 70110. mm⁴
- J_{xy} = -85615. mm⁴
- J_u = 259108. mm⁴
- J_v = 31327. mm⁴
- α = arctg(2J_{xy}/(J_y-J_x))/2 = .4253
- c = cos α = .9109
- s = sin α = .4126
- x_g = 19.22 mm
- y_g = 23.01 mm
- N = -672. N
- T_y = 1120. N
- M_x = 837760. Nmm
- x_m = 12. mm
- u_m = -16.08 mm
- v_m = -17.98 mm
- σ_m = N/A - Mcv/J_u - Msu/J_v = 229.2 N/mm²

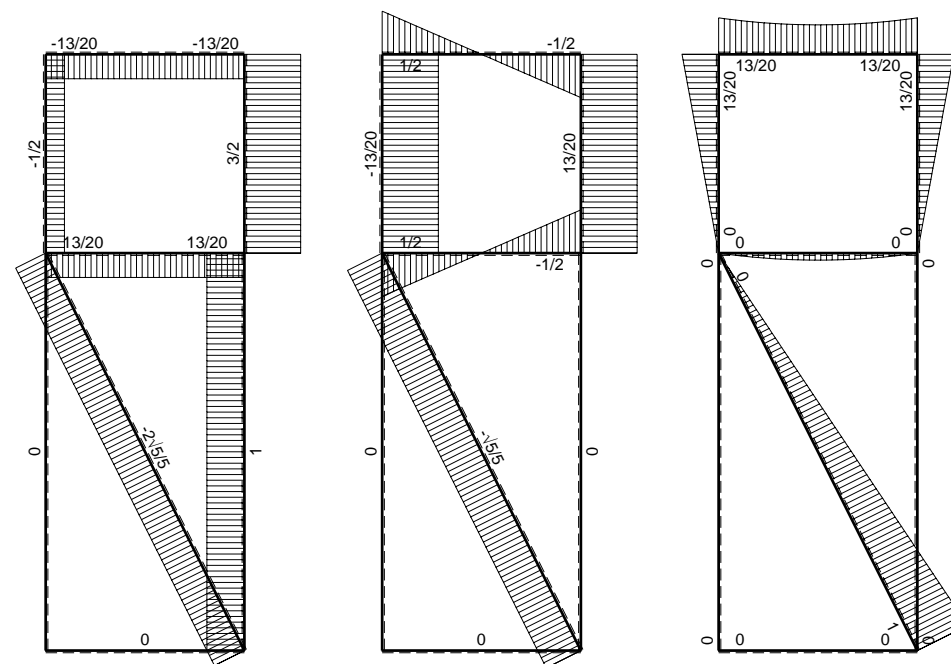
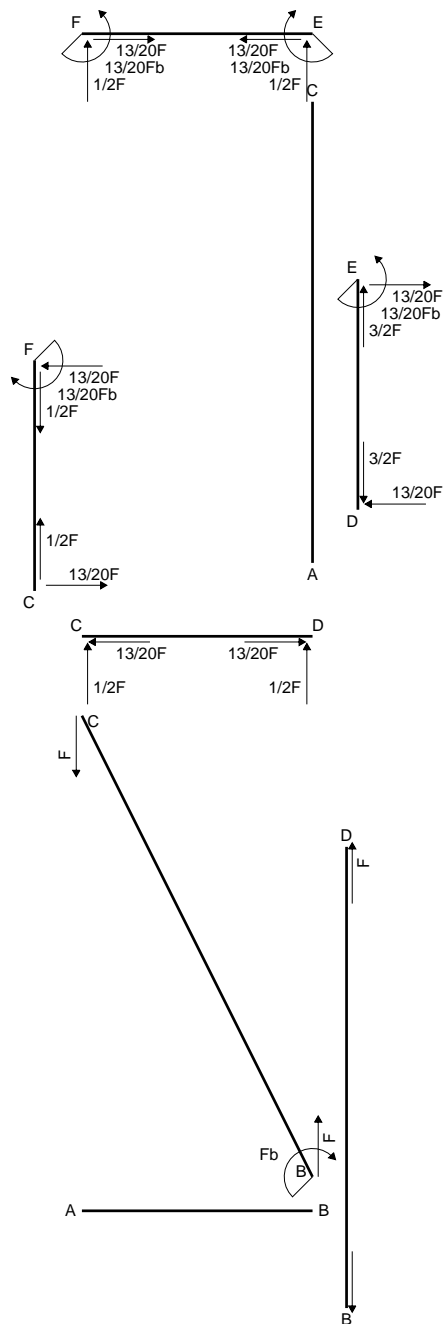

← ⊕ → F

↑ ⊕ ↓ F

⊕ ⊖ F_b

$$L_{DE}^{xx} = \int_0^b (x^2/b^2) 1/EJ dx = [1/3 x^3/b^2]_0^b 1/EJ$$

$$= (1/3 b) 1/EJ = 1/3 b/EJ$$

$$L_{ED}^{xx} = \int_0^b (1 - 2x/b + x^2/b^2) 1/EJ dx = [x - x^2/b + 1/3 x^3/b^2]_0^b 1/EJ$$

$$= (b - b + 1/3 b) 1/EJ = 1/3 b/EJ$$

$$L_{EF}^{xx} = \int_0^b (1) 1/EJ dx = [x]_0^b 1/EJ$$

$$= (b) 1/EJ = b/EJ$$

$$L_{FE}^{xx} = \int_0^b (1) 1/EJ dx = [x]_0^b 1/EJ$$

$$= (b) 1/EJ = b/EJ$$

$$L_{FC}^{xx} = \int_0^b (1 - 2x/b + x^2/b^2) 1/EJ dx = [x - x^2/b + 1/3 x^3/b^2]_0^b 1/EJ$$

$$= (b - b + 1/3 b) 1/EJ = 1/3 b/EJ$$

$$L_{CF}^{xx} = \int_0^b (x^2/b^2) 1/EJ dx = [1/3 x^3/b^2]_0^b 1/EJ$$

$$= (1/3 b) 1/EJ = 1/3 b/EJ$$

$$L_{EF}^{xo} = \int_0^b (1/2 x/b - 1/2 x^2/b^2) Fb 1/EJ dx + \int_0^b (1) \theta dx = [1/4 x^2/b - 1/6 x^3/b^2]_0^b Fb 1/EJ + [x]_0^b \theta$$

$$= (1/4 b - 1/6 b) Fb 1/EJ + (b) \theta = 13/12 Fb^2/EJ$$

$$L_{FE}^{xo} = \int_0^b (1/2 x/b - 1/2 x^2/b^2) Fb 1/EJ dx + \int_0^b (-1) \theta dx = [1/4 x^2/b - 1/6 x^3/b^2]_0^b Fb 1/EJ + [-x]_0^b \theta$$

$$= (1/4 b - 1/6 b) Fb 1/EJ + (-b) \theta = 13/12 Fb^2/EJ$$

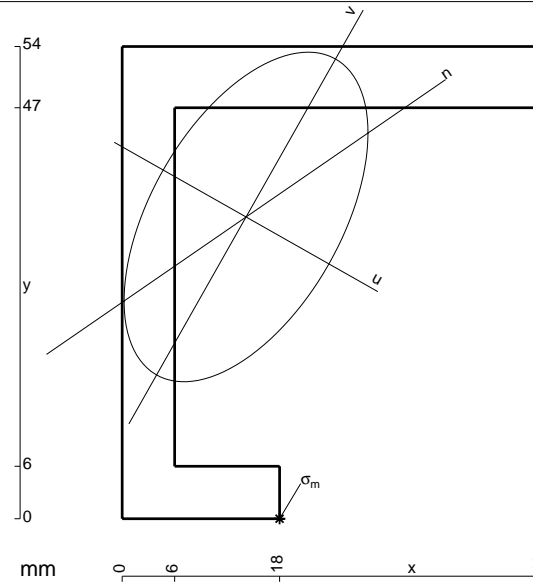

- A = 690. mm²
- J_x = 245079. mm⁴
- J_y = 134213. mm⁴
- J_{xy} = 92417. mm⁴
- J_u = 297413. mm⁴
- J_v = 81879. mm⁴
- α = arctg(2J_{xy}/(J_y-J_x))/2 = -.5153
- c = cosα = .8702
- s = sinα = -.4928
- x_g = 14.17 mm
- y_g = 34.51 mm
- N = -1467. N
- T_y = -733.4 N
- M_x = 1180800. Nmm
- x_m = 18. mm
- u_m = 20.34 mm
- v_m = -28.14 mm
- σ_m = N/A - Mcv/J_u - Msu/J_v = 239.6 N/mm²

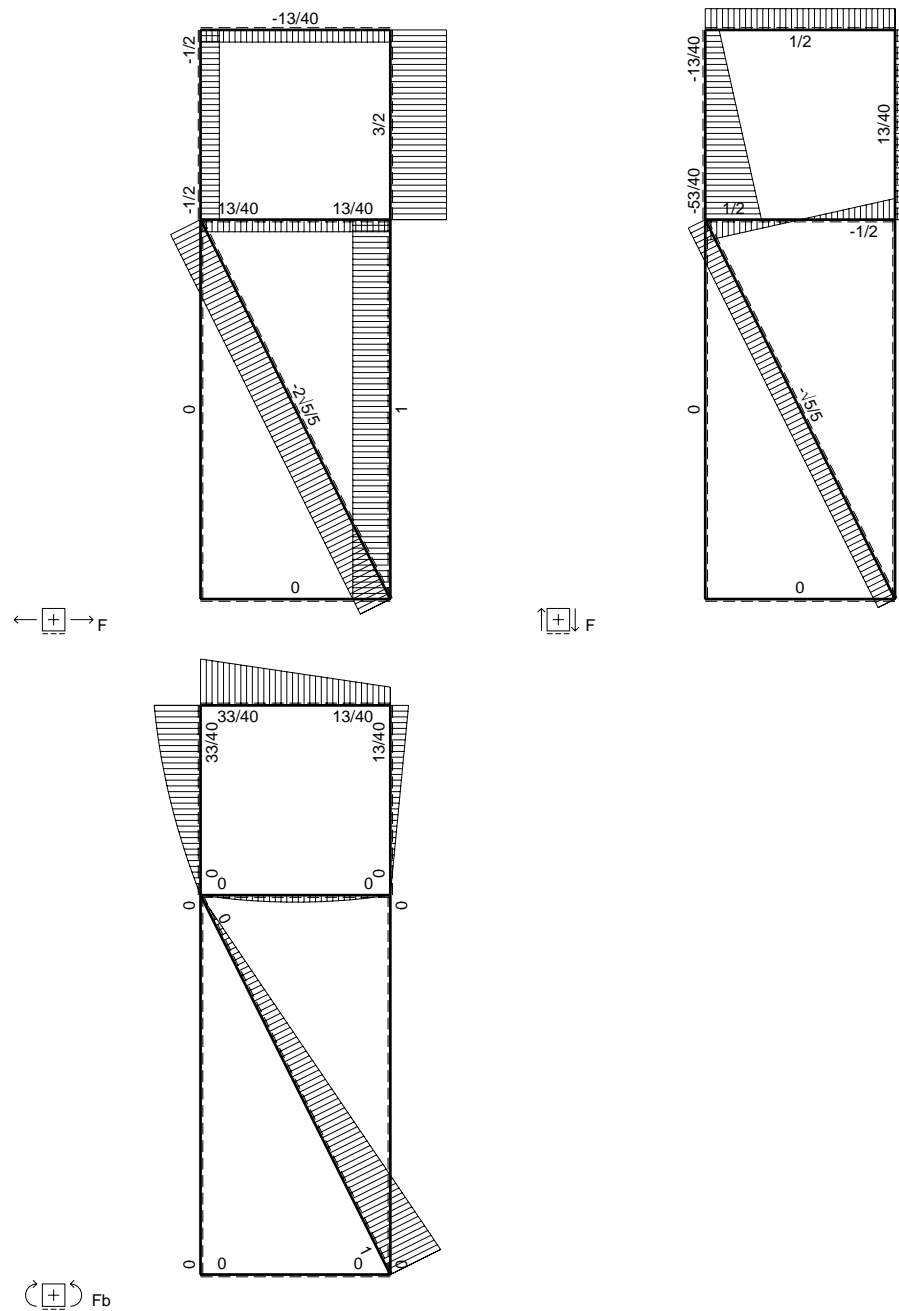
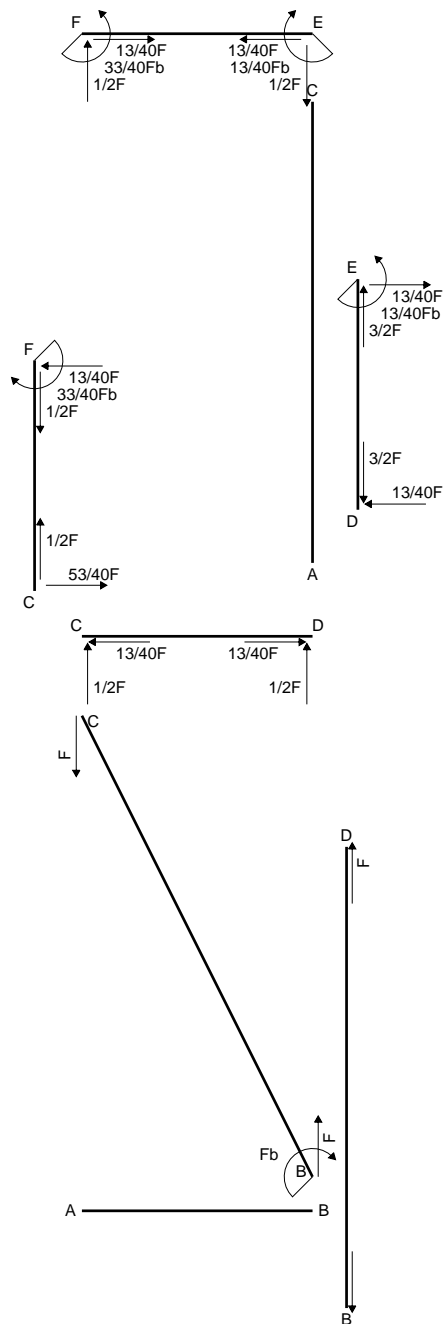

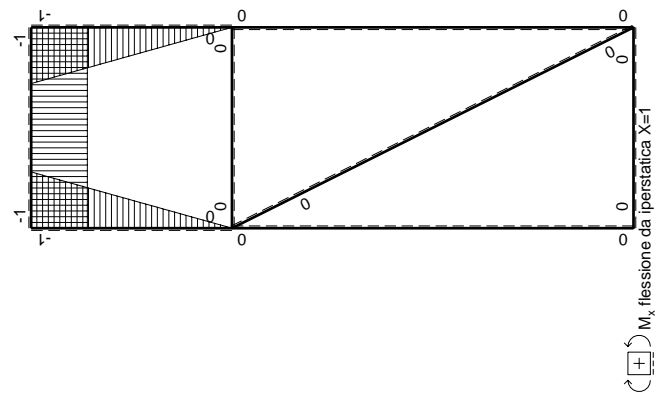
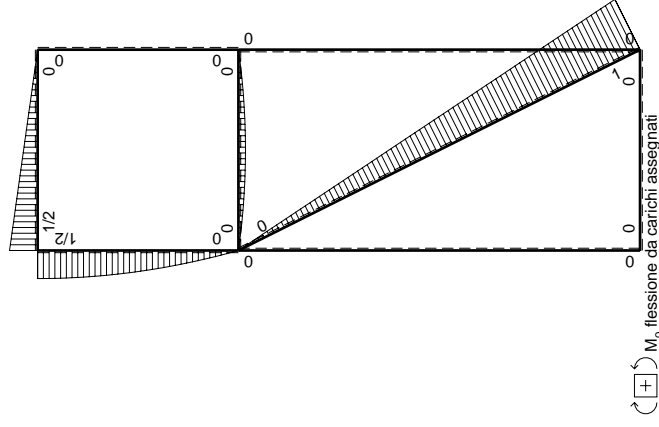
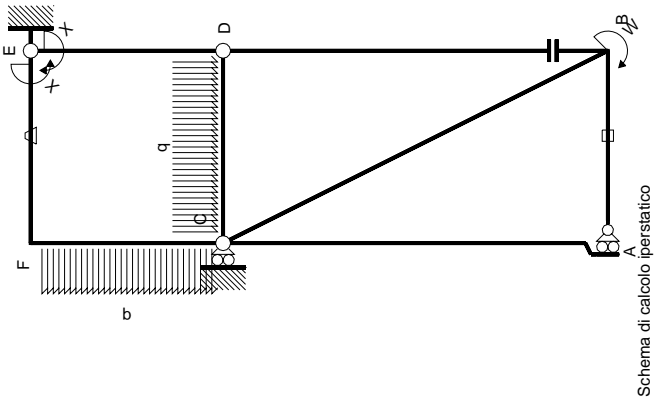

Quadro contributi PLV per iperstatica $X=W_{EP}$

\leftarrow	$M_x(x)$	$M_0(x)$	θ	$M_x M_0$	$M_x \theta$	$M_x M_x$	$\int M_x (M_0/EJ + \theta) dx$	$\int M_x M_x / EIdx$
AB b	0	0	0	0	0	0	0+0	0
BA b	0	0	0	0	0	0	0	0
BC $\sqrt{5}b$	$Fb - \sqrt{5}/5Fx$	0	0	0	0	0	0+0	0
CA 2b	0	0	0	0	0	0	0+0	0
DB 2b	0	0	0	0	0	0	0+0	0
ED b	$-x/b$	0	0	0	0	0	0+0	$1/3Xb/EJ$
CD b	$1/2Fx - 1/2qx^2$	0	0	0	0	0	0+0	0
DC b	$-1/2Fx + 1/2qx^2$	0	0	0	0	0	0+0	0
EF b	-1	$1/2Fx$	$-Fb/EJ$	$-1/2Fx$	Fb/EJ	Fb/EJ	1	Xb/EJ
FE b	1	$-1/2Fb + 1/2Fx$	Fb/EJ	$-1/2Fb + 1/2Fx$	Fb/EJ	Fb/EJ	1	$(-1/4+1)Fb^2/EJ$
FC b	$-1+x/b$	$1/2Fb - 1/2qx^2$	0	$-1/2Fb + 1/2Fx + 1/2Fx^2/b - 1/2qx^3/b$	0	0	x^2/b^2	$1/3Xb/EJ$
CF b	x/b	$-Fx + 1/2qx^2$	0	$-Fx^2/b + 1/2qx^3/b$	0	0	x^2/b^2	$1/3Xb/EJ$
totali								$5/3Xb/EJ$
								$-13/40Fb$

Sviluppi di calcolo iperstatica

$$L_{DE}^{xx} = \int_0^b (x^2/b^2) 1/EJ dx = [1/3 x^3/b^2]_0^b 1/EJ$$

$$= (1/3 b) 1/EJ = 1/3 b/EJ$$

$$L_{ED}^{xx} = \int_0^b (1 - 2x/b + x^2/b^2) 1/EJ dx = [x - x^2/b + 1/3 x^3/b^2]_0^b 1/EJ$$

$$= (b - b + 1/3 b) 1/EJ = 1/3 b/EJ$$

$$L_{EF}^{xx} = \int_0^b (1) 1/EJ dx = [x]_0^b 1/EJ$$

$$= (b) 1/EJ = b/EJ$$

$$L_{FE}^{xx} = \int_0^b (1) 1/EJ dx = [x]_0^b 1/EJ$$

$$= (b) 1/EJ = b/EJ$$

$$L_{FC}^{xx} = \int_0^b (1 - 2x/b + x^2/b^2) 1/EJ dx = [x - x^2/b + 1/3 x^3/b^2]_0^b 1/EJ$$

$$= (b - b + 1/3 b) 1/EJ = 1/3 b/EJ$$

$$L_{CF}^{xx} = \int_0^b (x^2/b^2) 1/EJ dx = [1/3 x^3/b^2]_0^b 1/EJ$$

$$= (1/3 b) 1/EJ = 1/3 b/EJ$$

$$L_{EF}^{xo} = \int_0^b (-1/2 x/b) Fb 1/EJ dx + \int_0^b (1) \theta dx = [-1/4 x^2/b]_0^b Fb 1/EJ + [x]_0^b \theta$$

$$= (-1/4 b) Fb 1/EJ + (b) \theta = 3/4 Fb^2/EJ$$

$$L_{FE}^{xo} = \int_0^b (-1/2 + 1/2 x/b) Fb 1/EJ dx + \int_0^b (-1) \theta dx = [-1/2 x + 1/4 x^2/b]_0^b Fb 1/EJ + [-x]_0^b \theta$$

$$= (-1/2 b + 1/4 b) Fb 1/EJ + (-b) \theta = 3/4 Fb^2/EJ$$

$$L_{FC}^{xo} = \int_0^b (-1/2 + 1/2 x/b + 1/2 x^2/b^2 - 1/2 x^3/b^3) Fb 1/EJ dx$$

$$= [-1/2 x + 1/4 x^2/b + 1/6 x^3/b^2 - 1/8 x^4/b^3]_0^b Fb 1/EJ$$

$$= (-1/2 b + 1/4 b + 1/6 b - 1/8 b) Fb 1/EJ = -5/24 Fb^2/EJ$$

$$L_{CF}^{xo} = \int_0^b (-x^2/b^2 + 1/2 x^3/b^3) Fb 1/EJ dx = [-1/3 x^3/b^2 + 1/8 x^4/b^3]_0^b Fb 1/EJ$$

$$= (-1/3 b + 1/8 b) Fb 1/EJ = -5/24 Fb^2/EJ$$

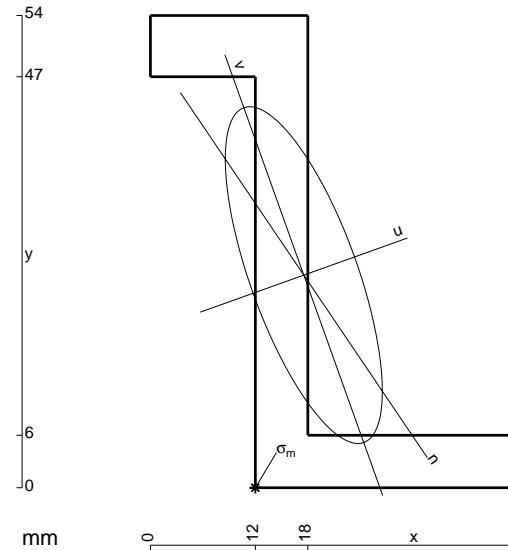

$A = 552. \text{ mm}^2$
 $J_x = 204861. \text{ mm}^4$
 $J_y = 44525. \text{ mm}^4$
 $J_{xy} = -65837. \text{ mm}^4$
 $J_u = 228430. \text{ mm}^4$
 $J_v = 20956. \text{ mm}^4$
 $\alpha = \text{artg}(2J_{xy}/(J_y - J_x))/2 = .3438$
 $c = \cos \alpha = .9415$
 $s = \sin \alpha = .3370$
 $x_g = 17.54 \text{ mm}$
 $y_g = 24.32 \text{ mm}$
 $N = -1574. \text{ N}$
 $T_y = -787.1 \text{ N}$
 $M_x = 668800. \text{ Nmm}$
 $x_m = 12. \text{ mm}$
 $u_m = -13.41 \text{ mm}$
 $v_m = -21.02 \text{ mm}$
 $\sigma_m = N/A - Mcv/J_u - Msu/J_v = 199.4 \text{ N/mm}^2$

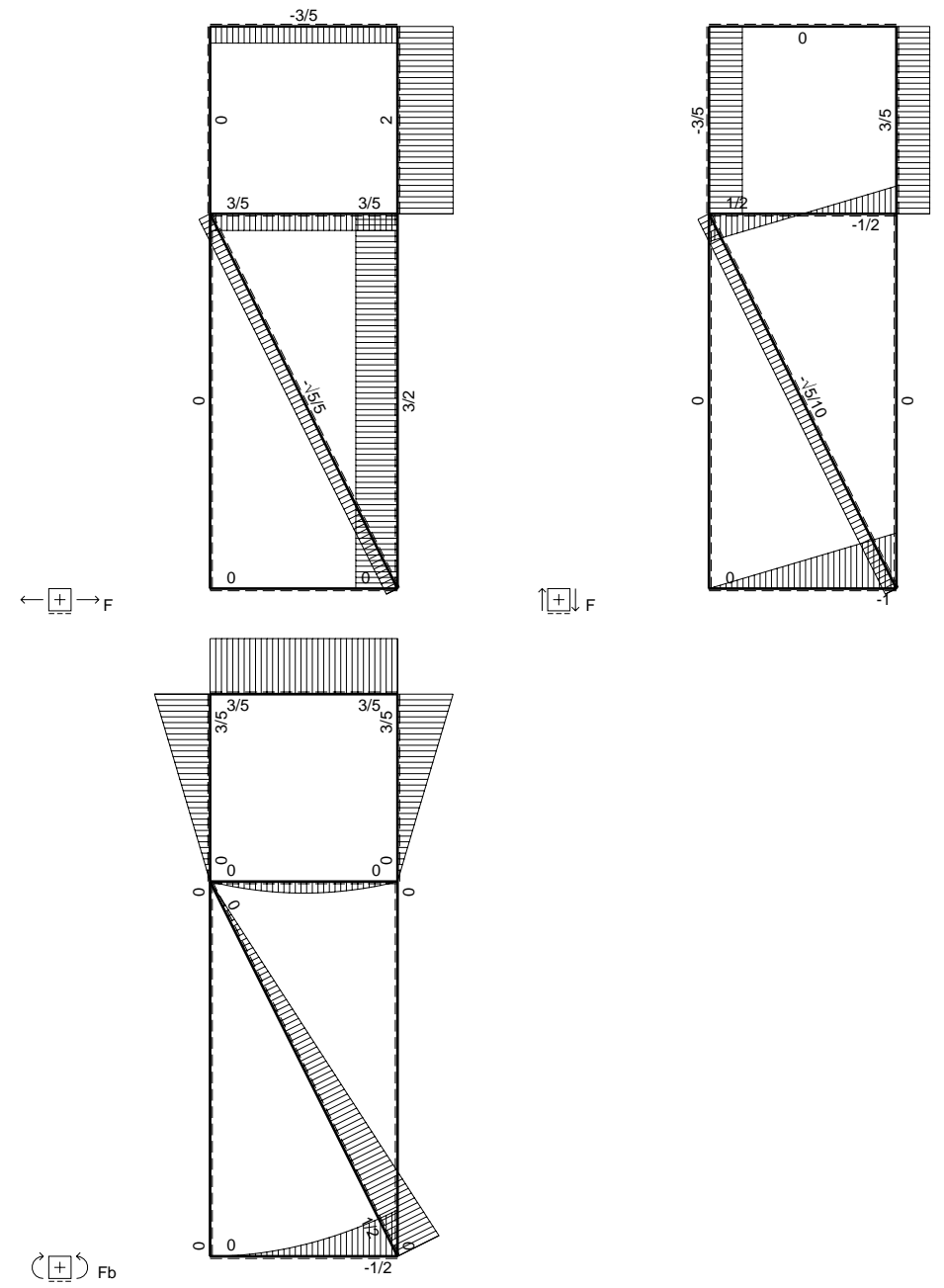
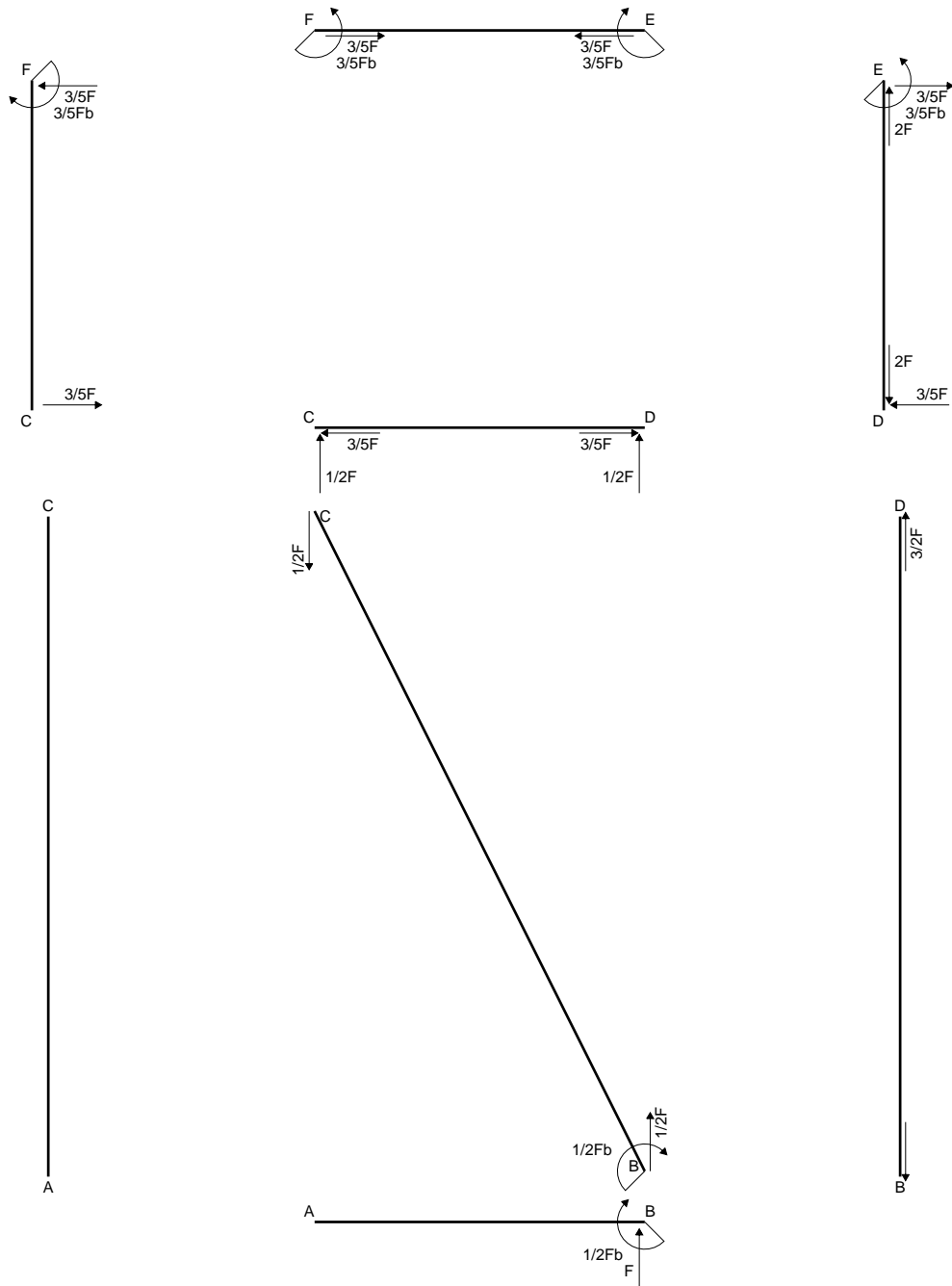

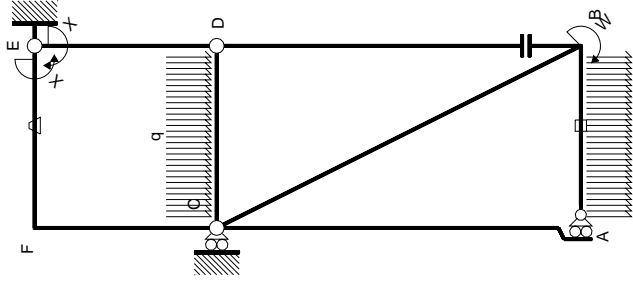

Schema di calcolo iperstatico

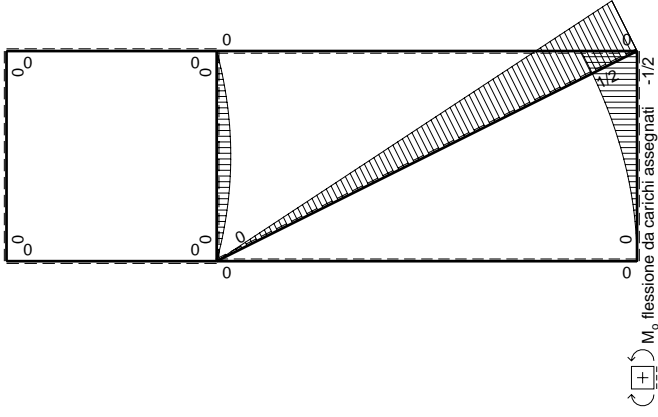

M_0 flessione da carichi assegnati -1/2

Quadro contributi PLV per iperstatica $X=W_{EF}$

\rightarrow	$M_x(x)$	$M_0(x)$	θ	$M_x M_0$	$M_x \theta$	$M_x M_x$	$\int M_x(M_0/EJ+\theta)dx$	$\int X M_x M_x / EJ dx$
AB b	0	$-1/2qx^2$	0	0	0	0	0+0	0
BA b	0	$1/2Fb-Fx+1/2qx^2$	0	0	0	0	0+0	0
BC $\sqrt{5}b$	0	$1/2Fb-\sqrt{5}/10Fx$	0	0	0	0	0	0
AC 2b	0	0	0	0	0	0	0+0	0
CA 2b	0	0	0	0	0	0	0+0	0
DB 2b	0	0	0	0	0	0	0+0	0
BD 2b	0	0	0	0	0	0	0+0	0
DE b	$-x/b$	0	0	0	0	x^2/b^2	0+0	$1/3Xb/EJ$
ED b	$1-x/b$	0	0	0	0	$1-2x/b+x^2/b^2$	0+0	0
CD b	0	$1/2Fx-1/2qx^2$	0	0	0	0	0+0	0
DC b	0	$-1/2Fx+1/2qx^2$	0	0	0	0	0+0	0
EF b	-1	0	$-Fb/EJ$	0	Fb/EJ	1	$(0+1)Fb^2/EJ$	Xb/EJ
FE b	1	0	Fb/EJ	0	Fb/EJ	1		
FC b	$-1+x/b$	0	0	0	0	$1-2x/b+x^2/b^2$	0+0	$1/3Xb/EJ$
CF b	x/b	0	0	0	0	x^2/b^2	Fb^2/EJ	$5/3Xb/EJ$
totali								
iperstatica $X=W_{EF}$								
$-3/5Fb$								

Sviluppi di calcolo iperstatica

M_x flessione da iperstatica $X=1$

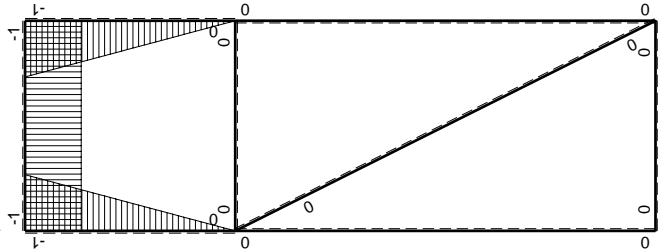

$$L_{DE}^{xx} = \int_0^b (x^2/b^2) 1/EJ dx = [1/3 x^3/b^2]_0^b 1/EJ$$

$$= (1/3 b) 1/EJ = 1/3 b/EJ$$

$$L_{ED}^{xx} = \int_0^b (1 - 2x/b + x^2/b^2) 1/EJ dx = [x - x^2/b + 1/3 x^3/b^2]_0^b 1/EJ$$

$$= (b - b + 1/3 b) 1/EJ = 1/3 b/EJ$$

$$L_{EF}^{xx} = \int_0^b (1) 1/EJ dx = [x]_0^b 1/EJ$$

$$= (b) 1/EJ = b/EJ$$

$$L_{FE}^{xx} = \int_0^b (1) 1/EJ dx = [x]_0^b 1/EJ$$

$$= (b) 1/EJ = b/EJ$$

$$L_{FC}^{xx} = \int_0^b (1 - 2x/b + x^2/b^2) 1/EJ dx = [x - x^2/b + 1/3 x^3/b^2]_0^b 1/EJ$$

$$= (b - b + 1/3 b) 1/EJ = 1/3 b/EJ$$

$$L_{CF}^{xx} = \int_0^b (x^2/b^2) 1/EJ dx = [1/3 x^3/b^2]_0^b 1/EJ$$

$$= (1/3 b) 1/EJ = 1/3 b/EJ$$

$$L_{EF}^{xo} = \int_0^b (1) \theta dx = [x]_0^b \theta$$

$$= (b) \theta = Fb^2/EJ$$

$$L_{FE}^{xo} = \int_0^b (-1) \theta dx = [-x]_0^b \theta$$

$$= (-b) \theta = Fb^2/EJ$$

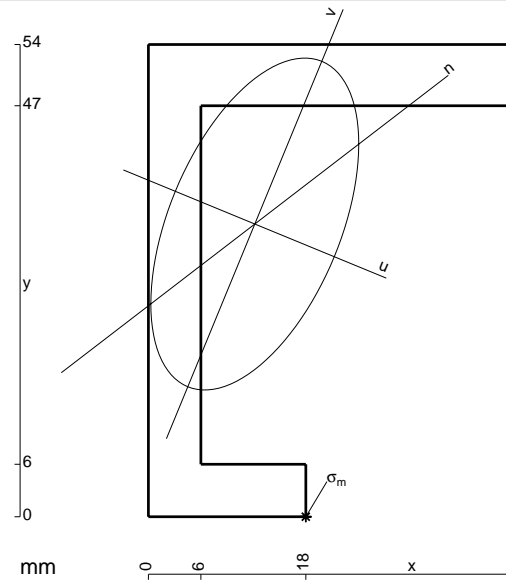

- A = 648. mm²
- J_x = 233472. mm⁴
- J_y = 91566. mm⁴
- J_{xy} = 70365. mm⁴
- J_u = 262446. mm⁴
- J_v = 62591. mm⁴
- α = arctg(2J_{xy}/(J_y-J_x))/2 = -.3906
- c = cos α = .9247
- s = sin α = -.3808
- x_g = 12.17 mm
- y_g = 33.47 mm
- N = 7600. N
- T_y = 2280. N
- M_x = 934800. Nmm
- x_m = 18. mm
- u_m = 18.14 mm
- v_m = -28.73 mm
- σ_m = N/A - Mcv/J_u - Msu/J_v = 209.5 N/mm²

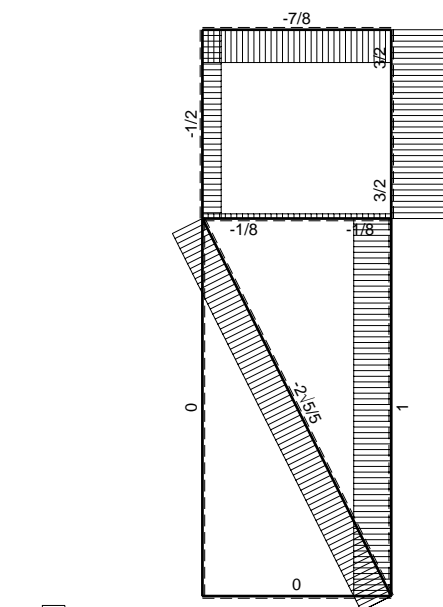
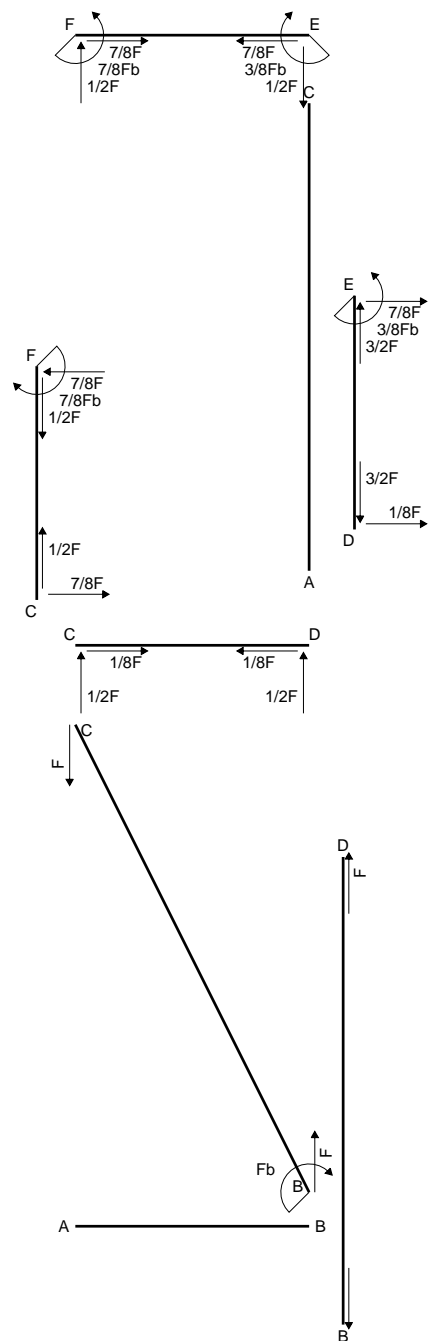

← ⊕ → F

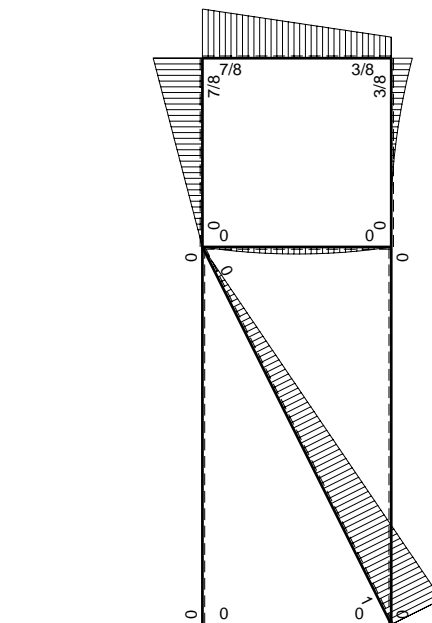

⊕ ⊖ Fb

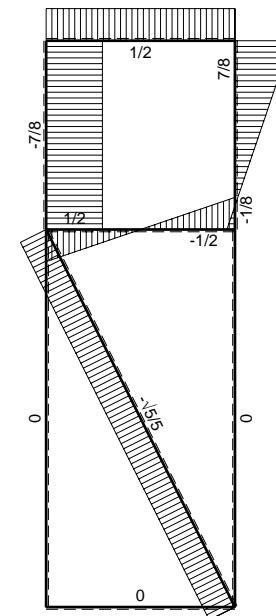

↑ ⊕ ↓ F

$$L_{DE}^{xx} = \int_0^b (x^2/b^2) 1/EJ dx = [1/3 x^3/b^2]_0^b 1/EJ$$

$$= (1/3 b) 1/EJ = 1/3 b/EJ$$

$$L_{ED}^{xx} = \int_0^b (1 - 2x/b + x^2/b^2) 1/EJ dx = [x - x^2/b + 1/3 x^3/b^2]_0^b 1/EJ$$

$$= (b - b + 1/3 b) 1/EJ = 1/3 b/EJ$$

$$L_{EF}^{xx} = \int_0^b (1) 1/EJ dx = [x]_0^b 1/EJ$$

$$= (b) 1/EJ = b/EJ$$

$$L_{FE}^{xx} = \int_0^b (1) 1/EJ dx = [x]_0^b 1/EJ$$

$$= (b) 1/EJ = b/EJ$$

$$L_{FC}^{xx} = \int_0^b (1 - 2x/b + x^2/b^2) 1/EJ dx = [x - x^2/b + 1/3 x^3/b^2]_0^b 1/EJ$$

$$= (b - b + 1/3 b) 1/EJ = 1/3 b/EJ$$

$$L_{CF}^{xx} = \int_0^b (x^2/b^2) 1/EJ dx = [1/3 x^3/b^2]_0^b 1/EJ$$

$$= (1/3 b) 1/EJ = 1/3 b/EJ$$

$$L_{DE}^{xo} = \int_0^b (1/2 x^2/b^2 - 1/2 x^3/b^3) Fb 1/EJ dx = [1/6 x^3/b^2 - 1/8 x^4/b^3]_0^b Fb 1/EJ$$

$$= (1/6 b - 1/8 b) Fb 1/EJ = 1/24 Fb^2/EJ$$

$$L_{ED}^{xo} = \int_0^b (1/2 x/b - x^2/b^2 + 1/2 x^3/b^3) Fb 1/EJ dx = [1/4 x^2/b - 1/3 x^3/b^2 + 1/8 x^4/b^3]_0^b Fb 1/EJ$$

$$= (1/4 b - 1/3 b + 1/8 b) Fb 1/EJ = 1/24 Fb^2/EJ$$

$$L_{EF}^{xo} = \int_0^b (-1/2 x/b) Fb 1/EJ dx + \int_0^b (1) \theta dx = [-1/4 x^2/b]_0^b Fb 1/EJ + [x]_0^b \theta$$

$$= (-1/4 b) Fb 1/EJ + (b) \theta = 3/4 Fb^2/EJ$$

$$L_{FE}^{xo} = \int_0^b (-1/2 + 1/2 x/b) Fb 1/EJ dx + \int_0^b (-1) \theta dx = [-1/2 x + 1/4 x^2/b]_0^b Fb 1/EJ + [-x]_0^b \theta$$

$$= (-1/2 b + 1/4 b) Fb 1/EJ + (-b) \theta = 3/4 Fb^2/EJ$$

$$L_{FC}^{xo} = \int_0^b (-1/2 + x/b - 1/2 x^2/b^2) Fb 1/EJ dx = [-1/2 x + 1/2 x^2/b - 1/6 x^3/b^2]_0^b Fb 1/EJ$$

$$= (-1/2 b + 1/2 b - 1/6 b) Fb 1/EJ = -1/6 Fb^2/EJ$$

$$L_{CF}^{xo} = \int_0^b (-1/2 x^2/b^2) Fb 1/EJ dx = [-1/6 x^3/b^2]_0^b Fb 1/EJ$$

$$= (-1/6 b) Fb 1/EJ = -1/6 Fb^2/EJ$$

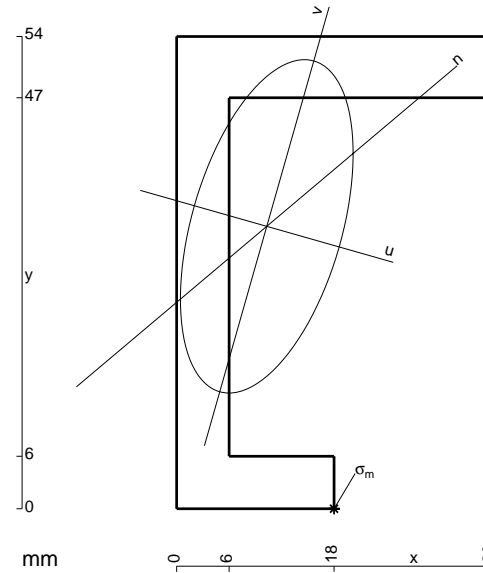

$$A = 606. \text{ mm}^2$$

$$J_x = 220278. \text{ mm}^4$$

$$J_y = 59103. \text{ mm}^4$$

$$J_{xy} = 49845. \text{ mm}^4$$

$$J_u = 234447. \text{ mm}^4$$

$$J_v = 44934. \text{ mm}^4$$

$$\alpha = \text{artg}(2J_{xy}/(J_y - J_x))/2 = -.2770$$

$$c = \cos \alpha = .9619$$

$$s = \sin \alpha = -.2734$$

$$x_g = 10.31 \text{ mm}$$

$$y_g = 32.29 \text{ mm}$$

$$N = -2039. \text{ N}$$

$$T_y = -1020. \text{ N}$$

$$M_x = 1026000. \text{ Nmm}$$

$$x_m = 18. \text{ mm}$$

$$u_m = 16.23 \text{ mm}$$

$$v_m = -28.96 \text{ mm}$$

$$\sigma_m = N/A - Mcv/J_u - Msu/J_v = 219.9 \text{ N/mm}^2$$

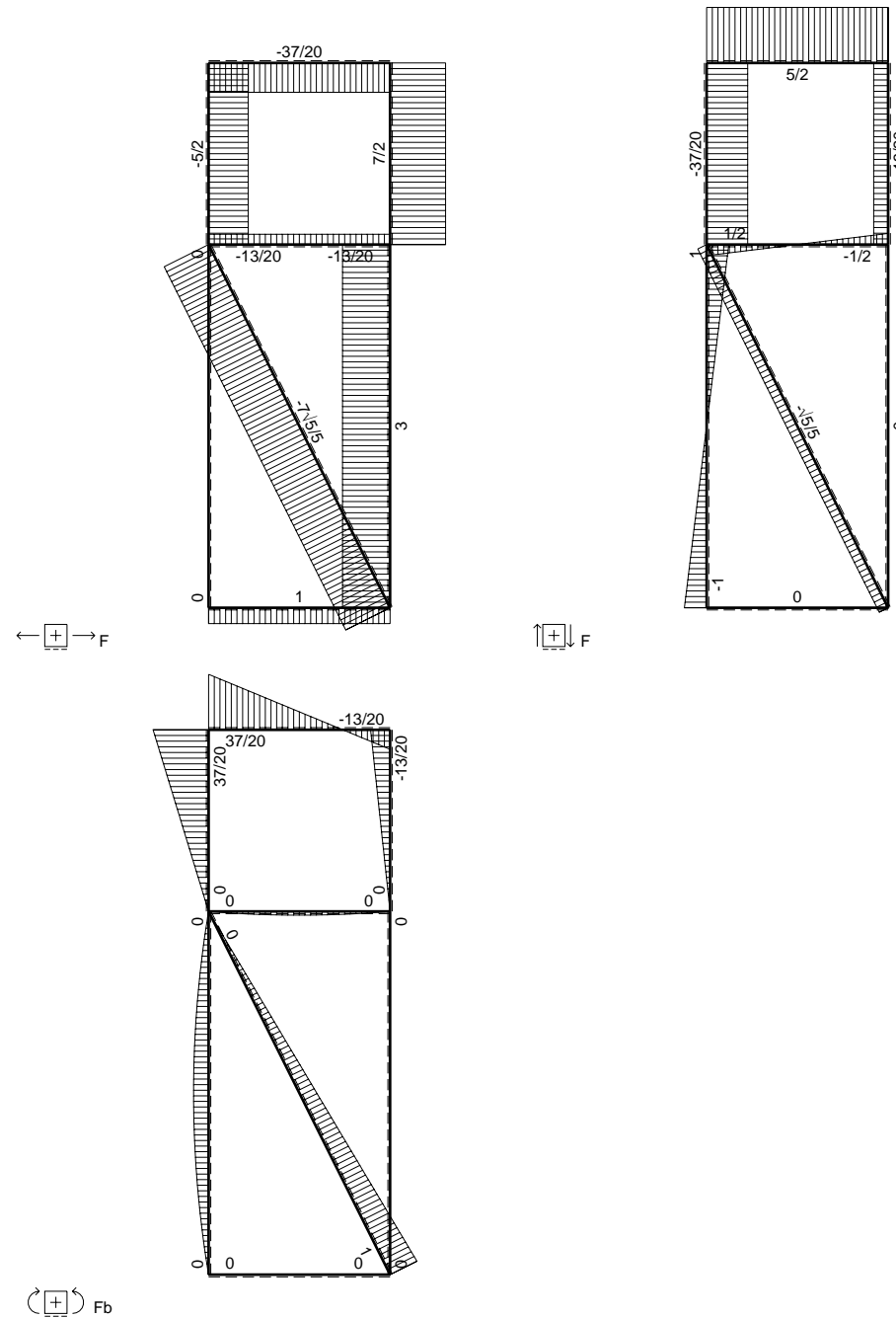
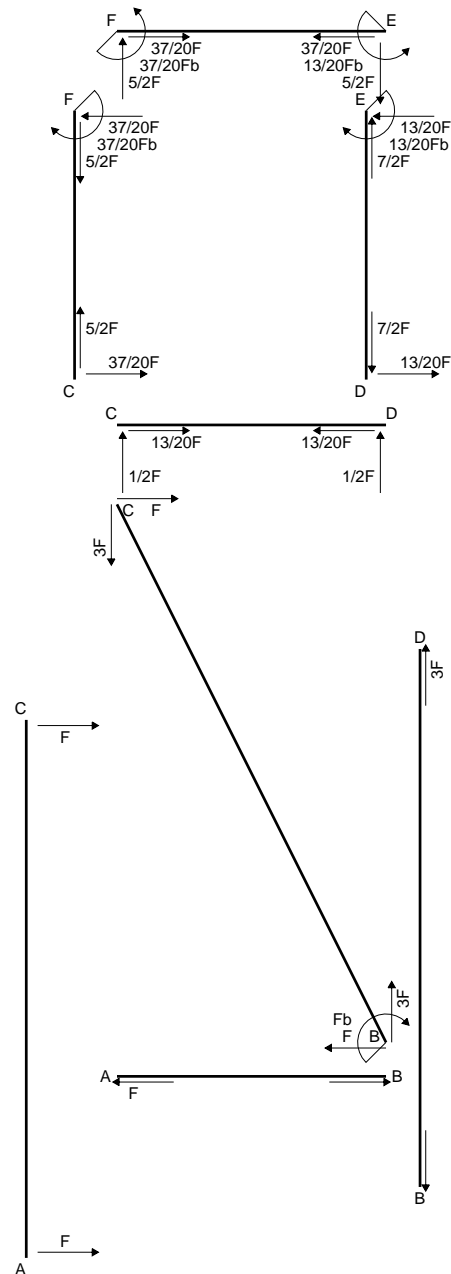

$$L_{DE}^{xx} = \int_0^b (x^2/b^2) 1/EJ dx = [1/3 x^3/b^2]_0^b 1/EJ$$

$$= (1/3 b) 1/EJ = 1/3 b/EJ$$

$$L_{ED}^{xx} = \int_0^b (1 - 2x/b + x^2/b^2) 1/EJ dx = [x - x^2/b + 1/3 x^3/b^2]_0^b 1/EJ$$

$$= (b - b + 1/3 b) 1/EJ = 1/3 b/EJ$$

$$L_{EF}^{xx} = \int_0^b (1) 1/EJ dx = [x]_0^b 1/EJ$$

$$= (b) 1/EJ = b/EJ$$

$$L_{FE}^{xx} = \int_0^b (1) 1/EJ dx = [x]_0^b 1/EJ$$

$$= (b) 1/EJ = b/EJ$$

$$L_{FC}^{xx} = \int_0^b (1 - 2x/b + x^2/b^2) 1/EJ dx = [x - x^2/b + 1/3 x^3/b^2]_0^b 1/EJ$$

$$= (b - b + 1/3 b) 1/EJ = 1/3 b/EJ$$

$$L_{CF}^{xx} = \int_0^b (x^2/b^2) 1/EJ dx = [1/3 x^3/b^2]_0^b 1/EJ$$

$$= (1/3 b) 1/EJ = 1/3 b/EJ$$

$$L_{EF}^{xo} = \int_0^b (-5/2 x/b) Fb 1/EJ dx + \int_0^b (1) \theta dx = [-5/4 x^2/b]_0^b Fb 1/EJ + [x]_0^b \theta$$

$$= (-5/4 b) Fb 1/EJ + (b) \theta = -1/4 Fb^2/EJ$$

$$L_{FE}^{xo} = \int_0^b (-5/2 + 5/2 x/b) Fb 1/EJ dx + \int_0^b (-1) \theta dx = [-5/2 x + 5/4 x^2/b]_0^b Fb 1/EJ + [-x]_0^b \theta$$

$$= (-5/2 b + 5/4 b) Fb 1/EJ + (-b) \theta = -1/4 Fb^2/EJ$$

$$L_{FC}^{xo} = \int_0^b (-5/2 + 5x/b - 5/2 x^2/b^2) Fb 1/EJ dx = [-5/2 x + 5/2 x^2/b - 5/6 x^3/b^2]_0^b Fb 1/EJ$$

$$= (-5/2 b + 5/2 b - 5/6 b) Fb 1/EJ = -5/6 Fb^2/EJ$$

$$L_{CF}^{xo} = \int_0^b (-5/2 x^2/b^2) Fb 1/EJ dx = [-5/6 x^3/b^2]_0^b Fb 1/EJ$$

$$= (-5/6 b) Fb 1/EJ = -5/6 Fb^2/EJ$$

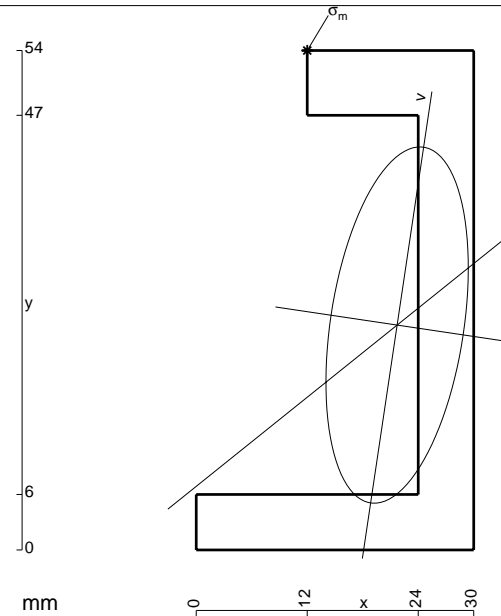

- A = 552. mm²
- J_x = 204861. mm⁴
- J_y = 32692. mm⁴
- J_{xy} = 26245. mm⁴
- J_u = 208773. mm⁴
- J_v = 28780. mm⁴
- α = arctg(2J_{xy}/(J_y-J_x))/2 = -.1480
- c = cos α = .9891
- s = sin α = -.1474
- x_g = 21.72 mm
- y_g = 24.32 mm
- N = -3025. N
- T_y = -2239. N
- M_x = 1096870. Nmm
- x_m = 12. mm
- y_m = 54. mm
- u_m = -13.99 mm
- v_m = 27.93 mm
- σ_m = N/A - Mcv/J_v - Msu/J_u = -229.2 N/mm²

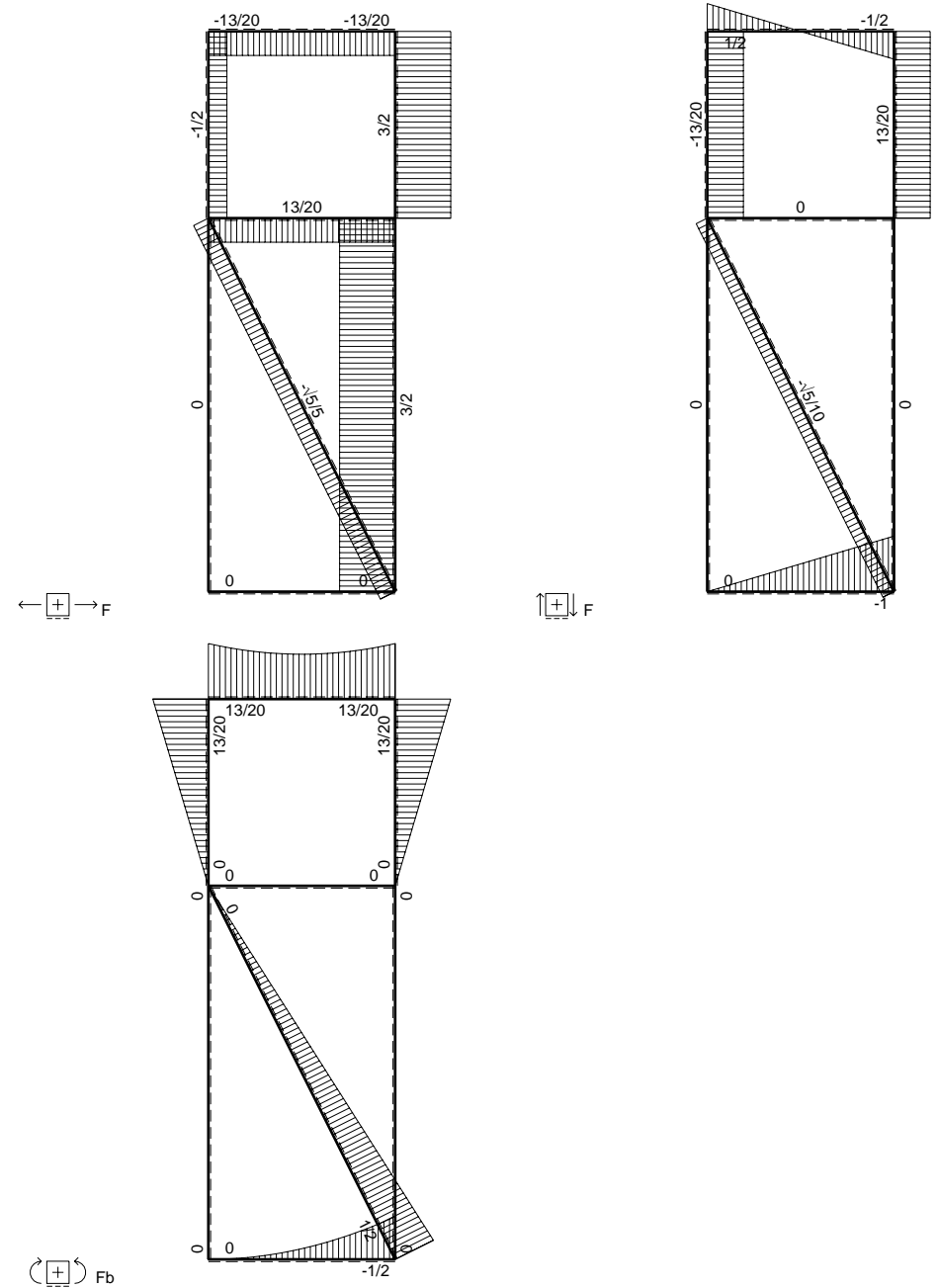
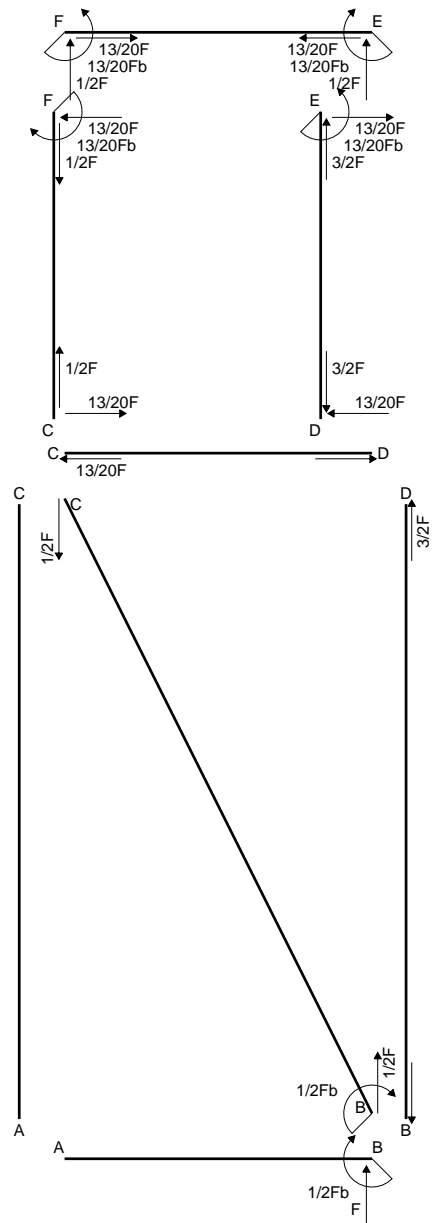

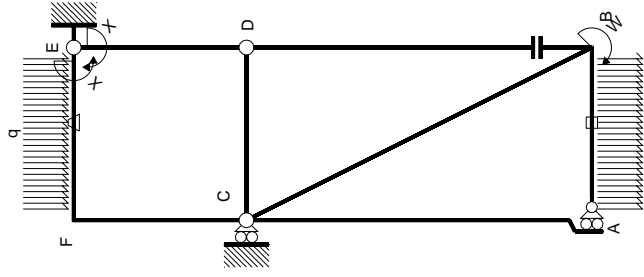

Schema di calcolo iperstatico

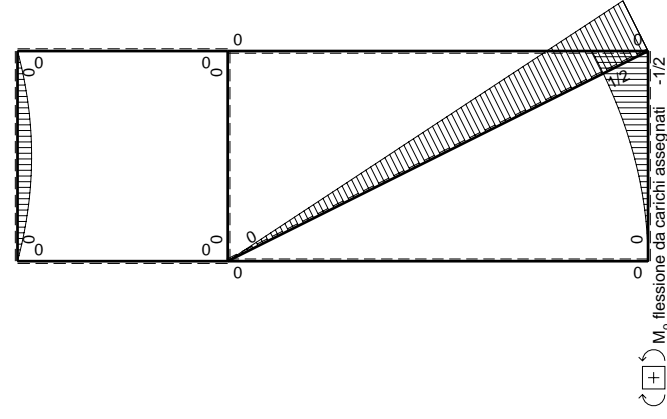

Quadro contributi PLV per iperstatica $X=W_{EP}$

\leftarrow	$M_x(x)$	$M_0(x)$	θ	$M_x M_0$	$M_x \theta$	$M_x M_x$	$\int M_x(M_0/EJ+\theta)dx$	$\int M_x M_x/EJ dx$
AB b	0	$-1/2qx^2$	0	0	0	0	0+0	0
BA b	0	$1/2Fb-Fx+1/2qx^2$	0	0	0	0	0	0
BC $\sqrt{5}b$	0	$1/2Fb-\sqrt{5}/10Fx$	0	0	0	0	0	0
AC 2b	0	0	0	0	0	0	0+0	0
CA 2b	0	0	0	0	0	0	0	0
DB 2b	0	0	0	0	0	0	0+0	0
BD 2b	0	0	0	0	0	0	0	0
DE b	-x/b	0	0	0	0	0	0+0	0
ED b	1-x/b	0	0	0	0	0	0	0
CD b	0	0	0	0	0	0	0	0
DC b	0	0	0	0	0	0	0+0	0
EF b	-1	$-1/2Fx+1/2qx^2$	$-Fb/EJ$	$1/2Fx-1/2Fx^2/b$	Fb/EJ	1	$(1/12+1)Fb^2/EJ$	Xb/EJ
FE b	1	$1/2Fx-1/2qx^2$	Fb/EJ	$1/2Fx-1/2Fx^2/b$	Fb/EJ	1	$(1/12+1)Fb^2/EJ$	Xb/EJ
FC b	-1+x/b	0	0	0	0	0	0	$1/3Xb/EJ$
CF b	x/b	0	0	0	0	0	0	$1/3Xb/EJ$
totali							$13/12Fb^2/EJ$	$5/3Xb/EJ$
								$-13/20Fb$

Sviluppi di calcolo iperstatica

M_x flessione da iperstatica $X=1$

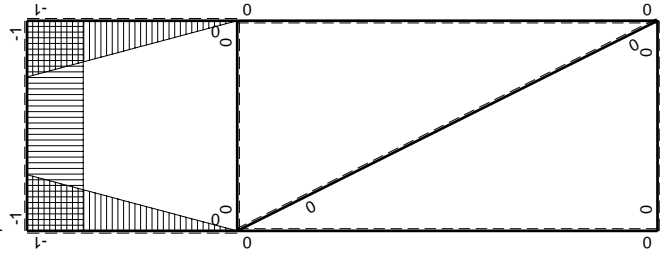

$$L_{DE}^{xx} = \int_0^b (x^2/b^2) 1/EJ dx = [1/3 x^3/b^2]_0^b 1/EJ$$

$$= (1/3 b) 1/EJ = 1/3 b/EJ$$

$$L_{ED}^{xx} = \int_0^b (1 - 2x/b + x^2/b^2) 1/EJ dx = [x - x^2/b + 1/3 x^3/b^2]_0^b 1/EJ$$

$$= (b - b + 1/3 b) 1/EJ = 1/3 b/EJ$$

$$L_{EF}^{xx} = \int_0^b (1) 1/EJ dx = [x]_0^b 1/EJ$$

$$= (b) 1/EJ = b/EJ$$

$$L_{FE}^{xx} = \int_0^b (1) 1/EJ dx = [x]_0^b 1/EJ$$

$$= (b) 1/EJ = b/EJ$$

$$L_{FC}^{xx} = \int_0^b (1 - 2x/b + x^2/b^2) 1/EJ dx = [x - x^2/b + 1/3 x^3/b^2]_0^b 1/EJ$$

$$= (b - b + 1/3 b) 1/EJ = 1/3 b/EJ$$

$$L_{CF}^{xx} = \int_0^b (x^2/b^2) 1/EJ dx = [1/3 x^3/b^2]_0^b 1/EJ$$

$$= (1/3 b) 1/EJ = 1/3 b/EJ$$

$$L_{EF}^{xo} = \int_0^b (1/2 x/b - 1/2 x^2/b^2) Fb 1/EJ dx + \int_0^b (1) \theta dx = [1/4 x^2/b - 1/6 x^3/b^2]_0^b Fb 1/EJ + [x]_0^b \theta$$

$$= (1/4 b - 1/6 b) Fb 1/EJ + (b) \theta = 13/12 Fb^2/EJ$$

$$L_{FE}^{xo} = \int_0^b (1/2 x/b - 1/2 x^2/b^2) Fb 1/EJ dx + \int_0^b (-1) \theta dx = [1/4 x^2/b - 1/6 x^3/b^2]_0^b Fb 1/EJ + [-x]_0^b \theta$$

$$= (1/4 b - 1/6 b) Fb 1/EJ + (-b) \theta = 13/12 Fb^2/EJ$$

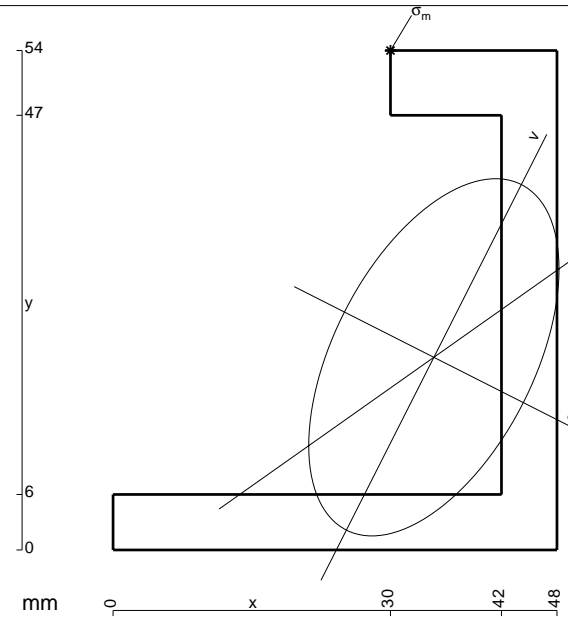

- A = 660. mm²
- J_x = 246224. mm⁴
- J_y = 120837. mm⁴
- J_{xy} = 85387. mm⁴
- J_u = 289462. mm⁴
- J_v = 77600. mm⁴
- α = arctg(2J_{xy}/(J_y-J_x))/2 = -.4687
- c = cos α = .8921
- s = sin α = -.4518
- x_g = 34.69 mm
- y_g = 20.83 mm
- N = -2269. N
- T_y = -1745. N
- M_x = 1202310. Nmm
- x_m = 30. mm
- y_m = 54. mm
- u_m = -19.17 mm
- v_m = 27.48 mm
- σ_m = N/A - Mcv/J_u - Msu/J_v = -239.4 N/mm²

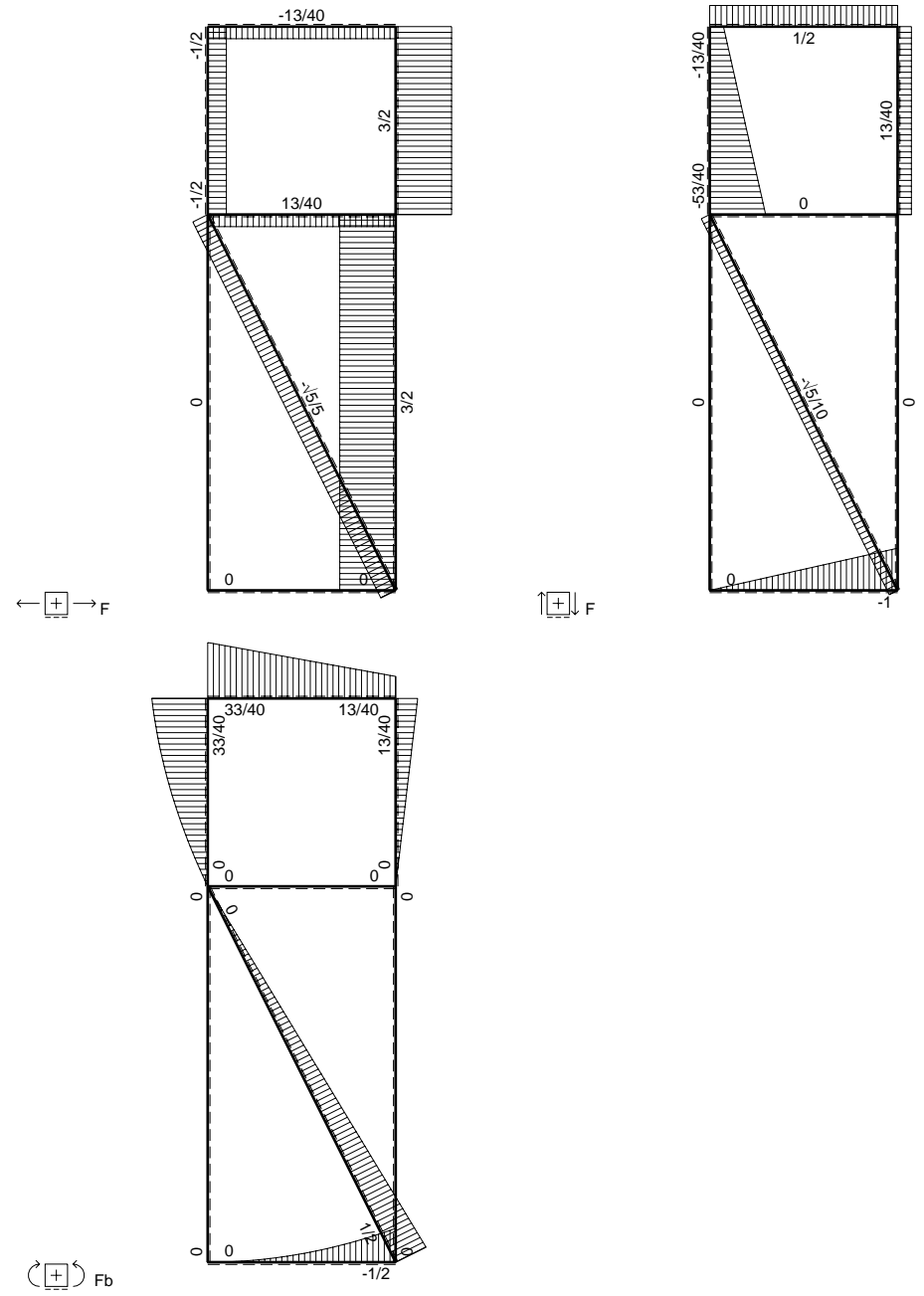
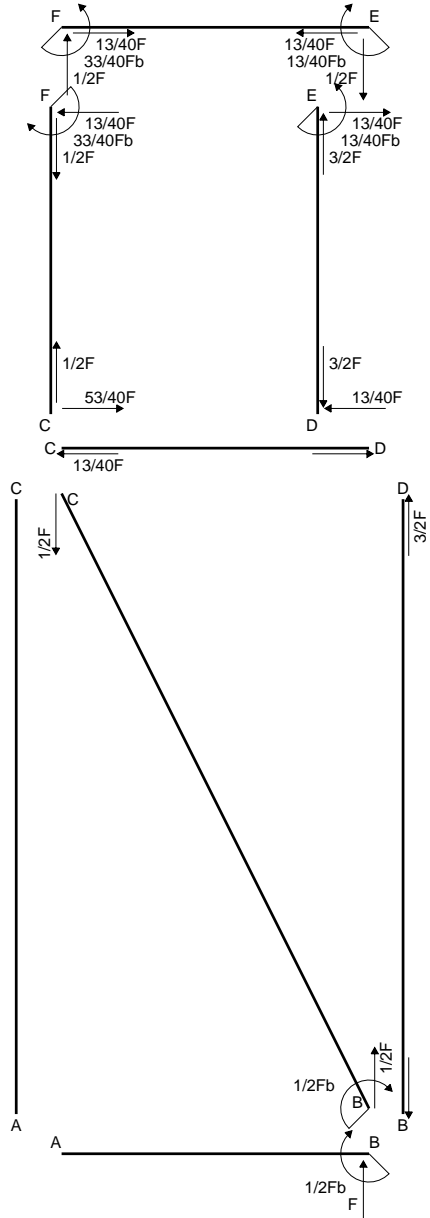

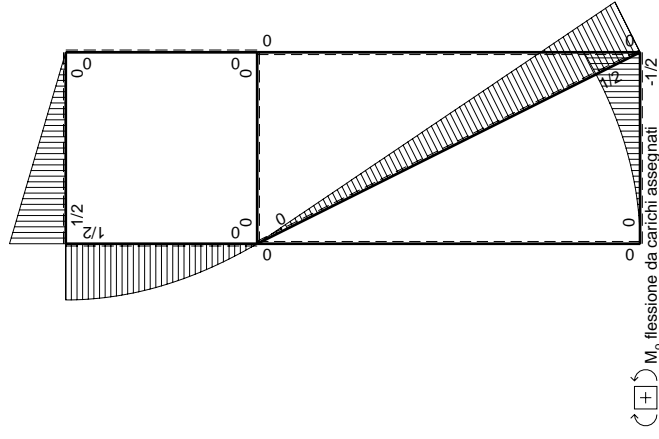
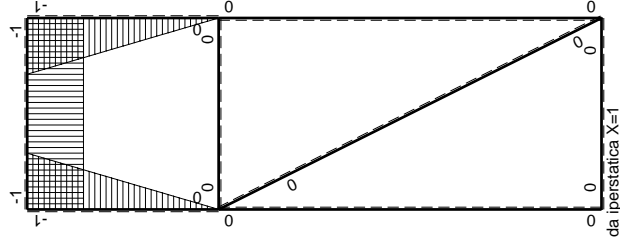
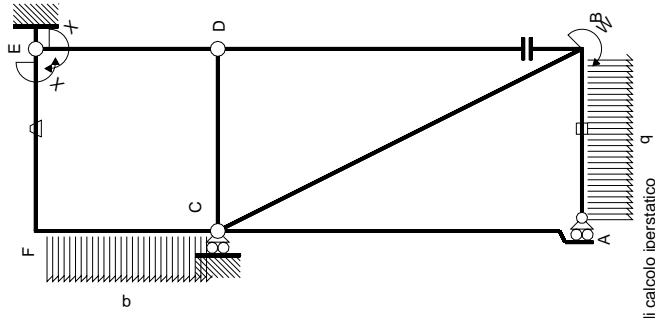

Quadro contributi PLV per iperstatica $X=W_{EF}$		$M_x(x)$		$M_0(x)$		$M_x\theta$	M_xM_x	$\int M_x(M_0/EJ+\theta)dx$	$\int M_xM_x/EJdx$
AB b	0	$-1/2qx^2$	0	0	0	0	0	0+0	0
BA b	0	$1/2Fb-Fx+1/2qx^2$	0	0	0	0	0	0	0
BC $\sqrt{5}b$	0	$1/2Fb-\sqrt{5}/10Fx$	0	0	0	0	0	0	0
AC 2b	0	0	0	0	0	0	0	0+0	0
CA 2b	0	0	0	0	0	0	0	0	0
DB 2b	0	0	0	0	0	0	0	0+0	0
BD 2b	0	0	0	0	0	0	0	0	0
DE b	-x/b	0	0	0	0	0	x^2/b^2	0+0	1/3Xb/EJ
ED b	1-x/b	0	0	0	0	0	$1-2x/b+x^2/b^2$	0+0	1/3Xb/EJ
CD b	0	0	0	0	0	0	0	0+0	0
DC b	0	0	0	0	0	0	0	0+0	0
EF b	-1	$1/2Fx$	-Fb/EJ	$-1/2Fx$	Fb/EJ	Fb/EJ	1	$(-1/4+1)Fb^2/EJ$	Xb/EJ
FE b	1	$-1/2Fb+1/2Fx$	Fb/EJ	$-1/2Fb+1/2Fx$	Fb/EJ	Fb/EJ	1	$(-1/4+1)Fb^2/EJ$	Xb/EJ
FC b	-1+x/b	$1/2Fb-1/2qx^2$	0	$-1/2Fb+1/2Fx+1/2Fx^2/b-1/2qx^3/b$	0	0	$1-2x/b+x^2/b^2$	$(-5/24+0)Fb^2/EJ$	1/3Xb/EJ
CF b	x/b	$-Fx+1/2qx^2$	0	$-Fx^2/b+1/2qx^3/b$	0	0	x^2/b^2	$13/24Fb^2/EJ$	5/3Xb/EJ
totali								$-13/40Fb$	

Sviluppi di calcolo iperstatica

$$L_{DE}^{xx} = \int_0^b (x^2/b^2) 1/EJ dx = [1/3 x^3/b^2]_0^b 1/EJ$$

$$= (1/3 b) 1/EJ = 1/3 b/EJ$$

$$L_{ED}^{xx} = \int_0^b (1 - 2x/b + x^2/b^2) 1/EJ dx = [x - x^2/b + 1/3 x^3/b^2]_0^b 1/EJ$$

$$= (b - b + 1/3 b) 1/EJ = 1/3 b/EJ$$

$$L_{EF}^{xx} = \int_0^b (1) 1/EJ dx = [x]_0^b 1/EJ$$

$$= (b) 1/EJ = b/EJ$$

$$L_{FE}^{xx} = \int_0^b (1) 1/EJ dx = [x]_0^b 1/EJ$$

$$= (b) 1/EJ = b/EJ$$

$$L_{FC}^{xx} = \int_0^b (1 - 2x/b + x^2/b^2) 1/EJ dx = [x - x^2/b + 1/3 x^3/b^2]_0^b 1/EJ$$

$$= (b - b + 1/3 b) 1/EJ = 1/3 b/EJ$$

$$L_{CF}^{xx} = \int_0^b (x^2/b^2) 1/EJ dx = [1/3 x^3/b^2]_0^b 1/EJ$$

$$= (1/3 b) 1/EJ = 1/3 b/EJ$$

$$L_{EF}^{xo} = \int_0^b (-1/2 x/b) Fb 1/EJ dx + \int_0^b (1) \theta dx = [-1/4 x^2/b]_0^b Fb 1/EJ + [x]_0^b \theta$$

$$= (-1/4 b) Fb 1/EJ + (b) \theta = 3/4 Fb^2/EJ$$

$$L_{FE}^{xo} = \int_0^b (-1/2 + 1/2 x/b) Fb 1/EJ dx + \int_0^b (-1) \theta dx = [-1/2 x + 1/4 x^2/b]_0^b Fb 1/EJ + [-x]_0^b \theta$$

$$= (-1/2 b + 1/4 b) Fb 1/EJ + (-b) \theta = 3/4 Fb^2/EJ$$

$$L_{FC}^{xo} = \int_0^b (-1/2 + 1/2 x/b + 1/2 x^2/b^2 - 1/2 x^3/b^3) Fb 1/EJ dx$$

$$= [-1/2 x + 1/4 x^2/b + 1/6 x^3/b^2 - 1/8 x^4/b^3]_0^b Fb 1/EJ$$

$$= (-1/2 b + 1/4 b + 1/6 b - 1/8 b) Fb 1/EJ = -5/24 Fb^2/EJ$$

$$L_{CF}^{xo} = \int_0^b (-x^2/b^2 + 1/2 x^3/b^3) Fb 1/EJ dx = [-1/3 x^3/b^2 + 1/8 x^4/b^3]_0^b Fb 1/EJ$$

$$= (-1/3 b + 1/8 b) Fb 1/EJ = -5/24 Fb^2/EJ$$

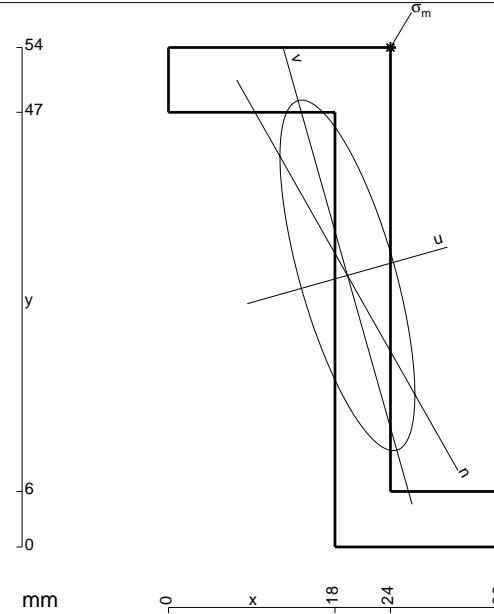

- A = 522. mm²
- J_x = 187606. mm⁴
- J_y = 27784. mm⁴
- J_{xy} = -49043. mm⁴
- J_u = 201455. mm⁴
- J_v = 13935. mm⁴
- α = arctg(2J_{xy}/(J_y-J_x))/2 = .2752
- c = cos α = .9624
- s = sin α = .2718
- x_g = 19.34 mm
- y_g = 29.36 mm
- N = -645. N
- T_y = -419.3 N
- M_x = 606623. Nmm
- x_m = 24. mm
- y_m = 54. mm
- u_m = 11.18 mm
- v_m = 22.45 mm
- σ_m = N/A - Mc_v/J_u - Ms_u/J_v = -198.5 N/mm²

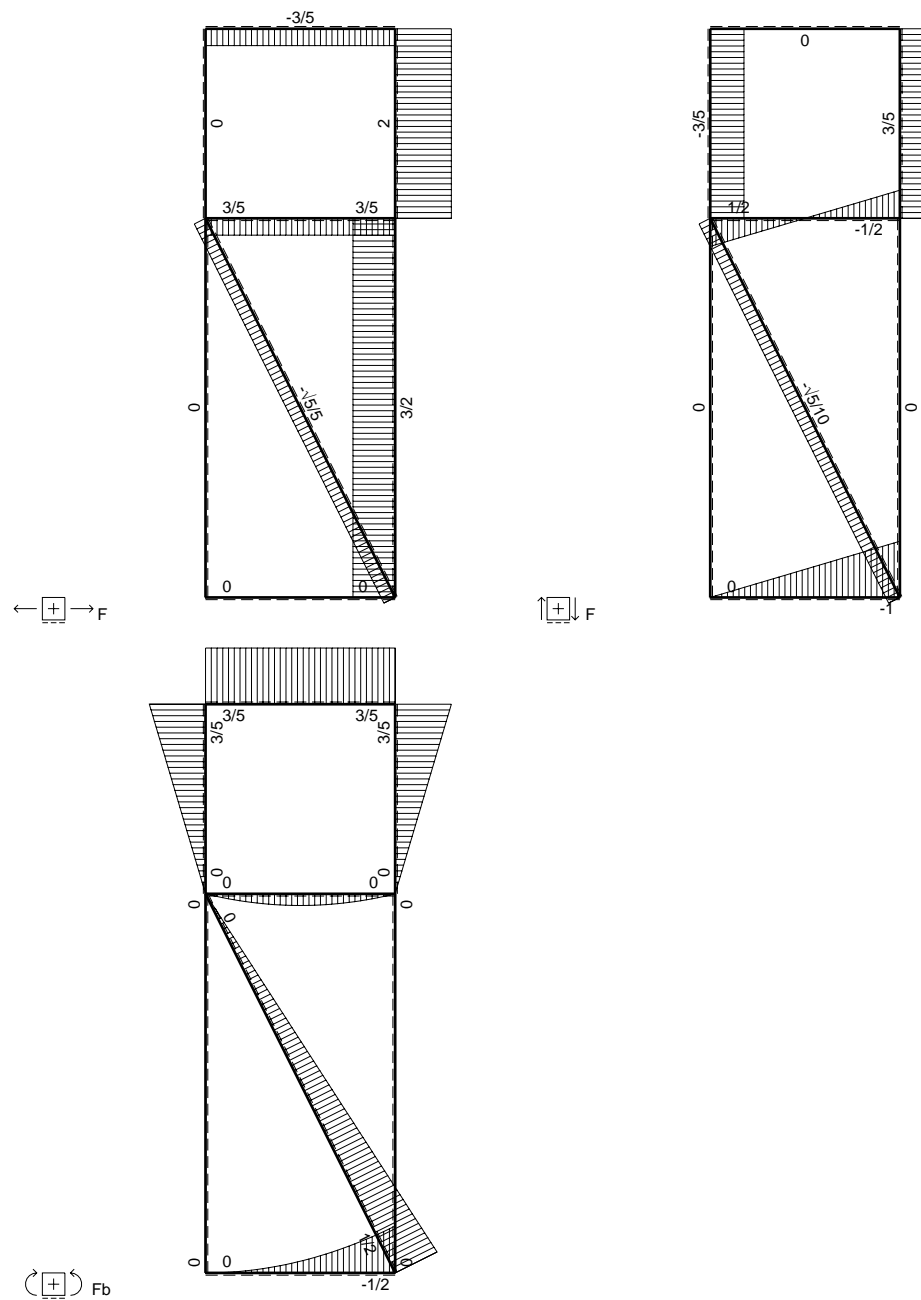
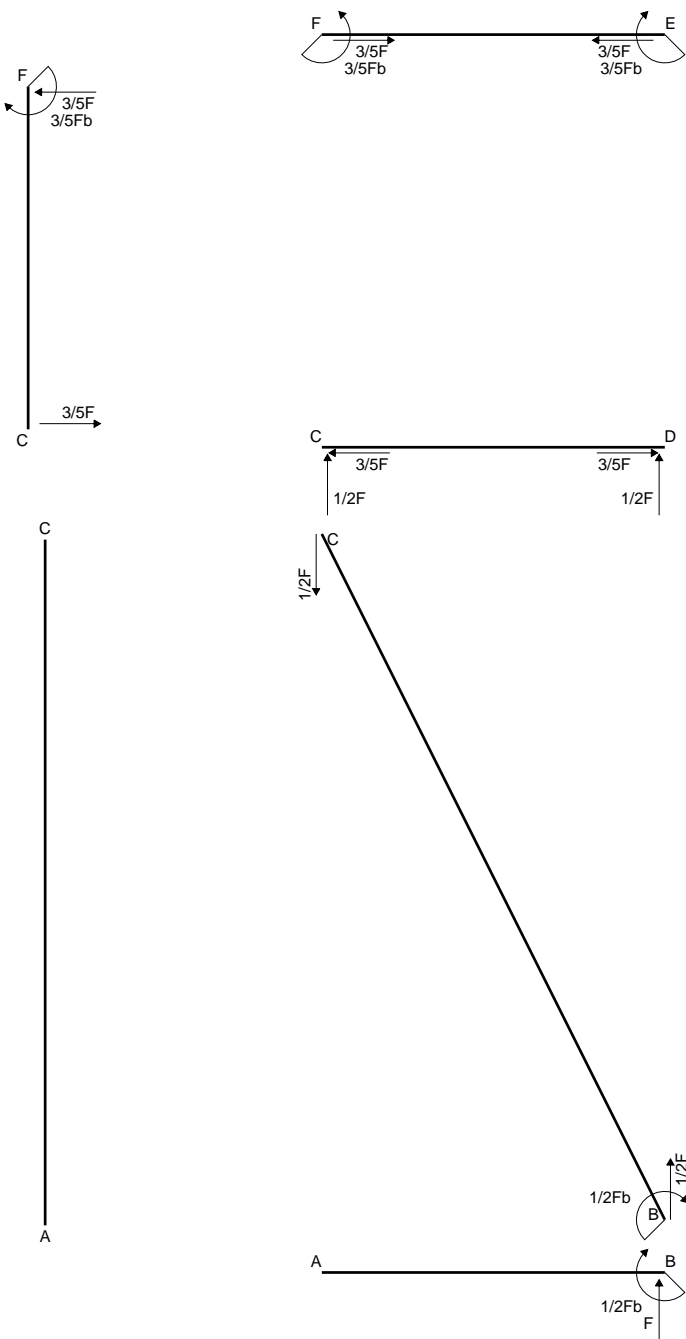

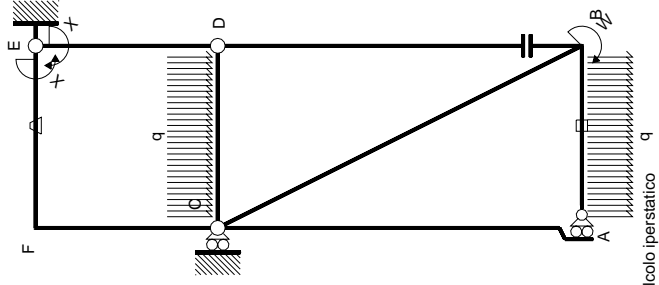

Schema di calcolo iperstatico

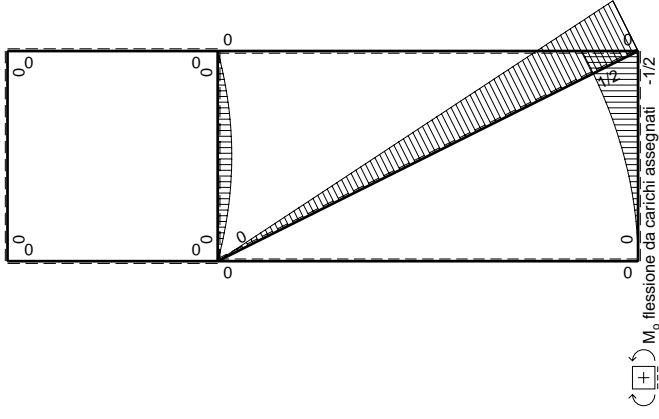

M_0 flessione da carichi assegnati -1/2

Quadro contributi PLV per iperstatica $X=W_{EF}$

\rightarrow	$M_x(x)$	$M_0(x)$	θ	$M_x M_0$	$M_x \theta$	$M_x M_x$	$\int M_x(M_0/EJ+\theta)dx$	$\int X M_x M_x / EJ dx$
AB b	0	$-1/2qx^2$	0	0	0	0	0+0	0
BA b	0	$1/2Fb-Fx+1/2qx^2$	0	0	0	0	0+0	0
BC $\sqrt{5}b$	0	$1/2Fb-\sqrt{5}/10Fx$	0	0	0	0	0	0
AC 2b	0	0	0	0	0	0	0+0	0
CA 2b	0	0	0	0	0	0	0+0	0
DB 2b	0	0	0	0	0	0	0+0	0
BD 2b	0	0	0	0	0	0	0+0	0
DE b	$-x/b$	0	0	0	0	x^2/b^2	0+0	$1/3Xb/EJ$
ED b	$1-x/b$	0	0	0	0	$1-2x/b+x^2/b^2$	0+0	$1/3Xb/EJ$
CD b	0	$1/2Fx-1/2qx^2$	0	0	0	0	0+0	0
DC b	0	$-1/2Fx+1/2qx^2$	0	0	0	0	0+0	0
EF b	-1	0	$-Fb/EJ$	0	Fb/EJ	1	$(0+1)Fb^2/EJ$	Xb/EJ
FE b	1	0	Fb/EJ	0	Fb/EJ	1	$(0+1)Fb^2/EJ$	Xb/EJ
FC b	$-1+x/b$	0	0	0	0	$1-2x/b+x^2/b^2$	0+0	$1/3Xb/EJ$
CF b	x/b	0	0	0	0	x^2/b^2	0+0	$1/3Xb/EJ$
	totali						Fb^2/EJ	$5/3Xb/EJ$
	iperstatica $X=W_{EF}$						$-3/5Fb$	

Sviluppi di calcolo iperstatica

M_x flessione da iperstatica $X=1$



$$L_{DE}^{xx} = \int_0^b (x^2/b^2) 1/EJ dx = [1/3 x^3/b^2]_0^b 1/EJ$$

$$= (1/3 b) 1/EJ = 1/3 b/EJ$$

$$L_{ED}^{xx} = \int_0^b (1 - 2x/b + x^2/b^2) 1/EJ dx = [x - x^2/b + 1/3 x^3/b^2]_0^b 1/EJ$$

$$= (b - b + 1/3 b) 1/EJ = 1/3 b/EJ$$

$$L_{EF}^{xx} = \int_0^b (1) 1/EJ dx = [x]_0^b 1/EJ$$

$$= (b) 1/EJ = b/EJ$$

$$L_{FE}^{xx} = \int_0^b (1) 1/EJ dx = [x]_0^b 1/EJ$$

$$= (b) 1/EJ = b/EJ$$

$$L_{FC}^{xx} = \int_0^b (1 - 2x/b + x^2/b^2) 1/EJ dx = [x - x^2/b + 1/3 x^3/b^2]_0^b 1/EJ$$

$$= (b - b + 1/3 b) 1/EJ = 1/3 b/EJ$$

$$L_{CF}^{xx} = \int_0^b (x^2/b^2) 1/EJ dx = [1/3 x^3/b^2]_0^b 1/EJ$$

$$= (1/3 b) 1/EJ = 1/3 b/EJ$$

$$L_{EF}^{xo} = \int_0^b (1) \theta dx = [x]_0^b \theta$$

$$= (b) \theta = Fb^2/EJ$$

$$L_{FE}^{xo} = \int_0^b (-1) \theta dx = [-x]_0^b \theta$$

$$= (-b) \theta = -Fb^2/EJ$$

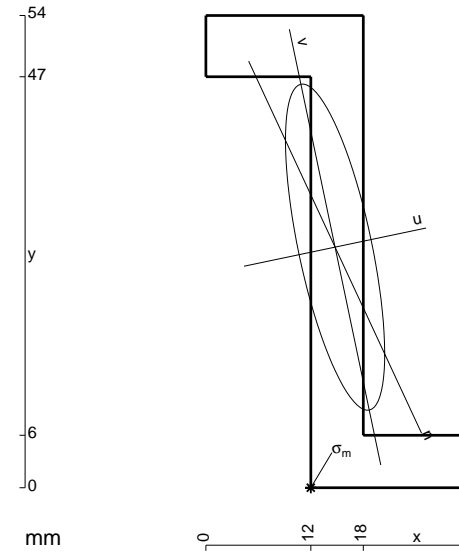

$$A = 480. \text{ mm}^2$$

$$J_x = 167026. \text{ mm}^4$$

$$J_y = 15456. \text{ mm}^4$$

$$J_{xy} = -33263. \text{ mm}^4$$

$$J_u = 174004. \text{ mm}^4$$

$$J_v = 8477. \text{ mm}^4$$

$$\alpha = \text{artg}(2J_{xy}/(J_y - J_x))/2 = .2068$$

$$c = \cos \alpha = .9787$$

$$s = \sin \alpha = .2053$$

$$x_g = 14.77 \text{ mm}$$

$$y_g = 27.51 \text{ mm}$$

$$N = 3200. \text{ N}$$

$$T_y = 960. \text{ N}$$

$$M_x = 576000. \text{ Nm}$$

$$x_m = 12. \text{ mm}$$

$$u_m = -8.365 \text{ mm}$$

$$v_m = -26.36 \text{ mm}$$

$$\sigma_m = N/A - Mcv/J_u - Msu/J_v = 208.8 \text{ N/mm}^2$$

$$L_{DE}^{xx} = \int_0^b (x^2/b^2) 1/EJ dx = [1/3 x^3/b^2]_0^b 1/EJ$$

$$= (1/3 b) 1/EJ = 1/3 b/EJ$$

$$L_{ED}^{xx} = \int_0^b (1 - 2x/b + x^2/b^2) 1/EJ dx = [x - x^2/b + 1/3 x^3/b^2]_0^b 1/EJ$$

$$= (b - b + 1/3 b) 1/EJ = 1/3 b/EJ$$

$$L_{EF}^{xx} = \int_0^b (1) 1/EJ dx = [x]_0^b 1/EJ$$

$$= (b) 1/EJ = b/EJ$$

$$L_{FE}^{xx} = \int_0^b (1) 1/EJ dx = [x]_0^b 1/EJ$$

$$= (b) 1/EJ = b/EJ$$

$$L_{FC}^{xx} = \int_0^b (1 - 2x/b + x^2/b^2) 1/EJ dx = [x - x^2/b + 1/3 x^3/b^2]_0^b 1/EJ$$

$$= (b - b + 1/3 b) 1/EJ = 1/3 b/EJ$$

$$L_{CF}^{xx} = \int_0^b (x^2/b^2) 1/EJ dx = [1/3 x^3/b^2]_0^b 1/EJ$$

$$= (1/3 b) 1/EJ = 1/3 b/EJ$$

$$L_{DE}^{xo} = \int_0^b (1/2 x^2/b^2 - 1/2 x^3/b^3) Fb 1/EJ dx = [1/6 x^3/b^2 - 1/8 x^4/b^3]_0^b Fb 1/EJ$$

$$= (1/6 b - 1/8 b) Fb 1/EJ = 1/24 Fb^2/EJ$$

$$L_{ED}^{xo} = \int_0^b (1/2 x/b - x^2/b^2 + 1/2 x^3/b^3) Fb 1/EJ dx = [1/4 x^2/b - 1/3 x^3/b^2 + 1/8 x^4/b^3]_0^b Fb 1/EJ$$

$$= (1/4 b - 1/3 b + 1/8 b) Fb 1/EJ = 1/24 Fb^2/EJ$$

$$L_{EF}^{xo} = \int_0^b (-1/2 x/b) Fb 1/EJ dx + \int_0^b (1) \theta dx = [-1/4 x^2/b]_0^b Fb 1/EJ + [x]_0^b \theta$$

$$= (-1/4 b) Fb 1/EJ + (b) \theta = 3/4 Fb^2/EJ$$

$$L_{FE}^{xo} = \int_0^b (-1/2 + 1/2 x/b) Fb 1/EJ dx + \int_0^b (-1) \theta dx = [-1/2 x + 1/4 x^2/b]_0^b Fb 1/EJ + [-x]_0^b \theta$$

$$= (-1/2 b + 1/4 b) Fb 1/EJ + (-b) \theta = 3/4 Fb^2/EJ$$

$$L_{FC}^{xo} = \int_0^b (-1/2 + x/b - 1/2 x^2/b^2) Fb 1/EJ dx = [-1/2 x + 1/2 x^2/b - 1/6 x^3/b^2]_0^b Fb 1/EJ$$

$$= (-1/2 b + 1/2 b - 1/6 b) Fb 1/EJ = -1/6 Fb^2/EJ$$

$$L_{CF}^{xo} = \int_0^b (-1/2 x^2/b^2) Fb 1/EJ dx = [-1/6 x^3/b^2]_0^b Fb 1/EJ$$

$$= (-1/6 b) Fb 1/EJ = -1/6 Fb^2/EJ$$

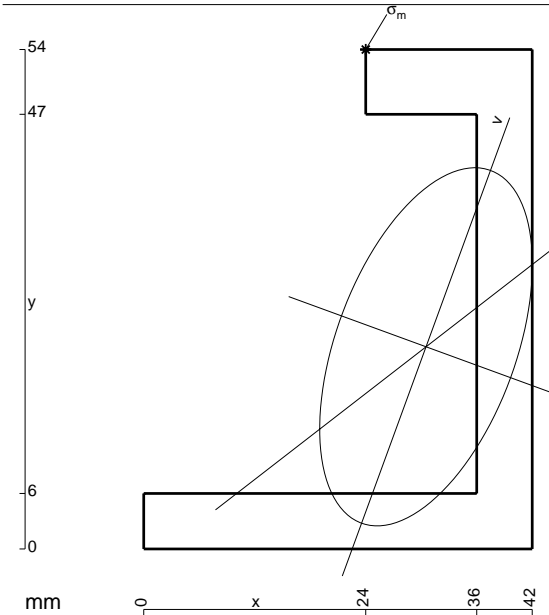

- A = 624. mm²
- J_x = 234015. mm⁴
- J_y = 82488. mm⁴
- J_{xy} = 63875. mm⁴
- J_u = 257348. mm⁴
- J_v = 59155. mm⁴
- α = arctg(2J_{xy}/(J_y-J_x))/2 = -.3502
- c = cos α = .9393
- s = sin α = -.3431
- x_g = 30.52 mm
- y_g = 21.86 mm
- N = -1680. N
- T_y = 960. N
- M_x = 1075200. Nmm
- x_m = 24. mm
- y_m = 54. mm
- u_m = -17.15 mm
- v_m = 27.96 mm
- σ_m = N/A - Mcv/J_u - Msu/J_v = -219.4 N/mm²

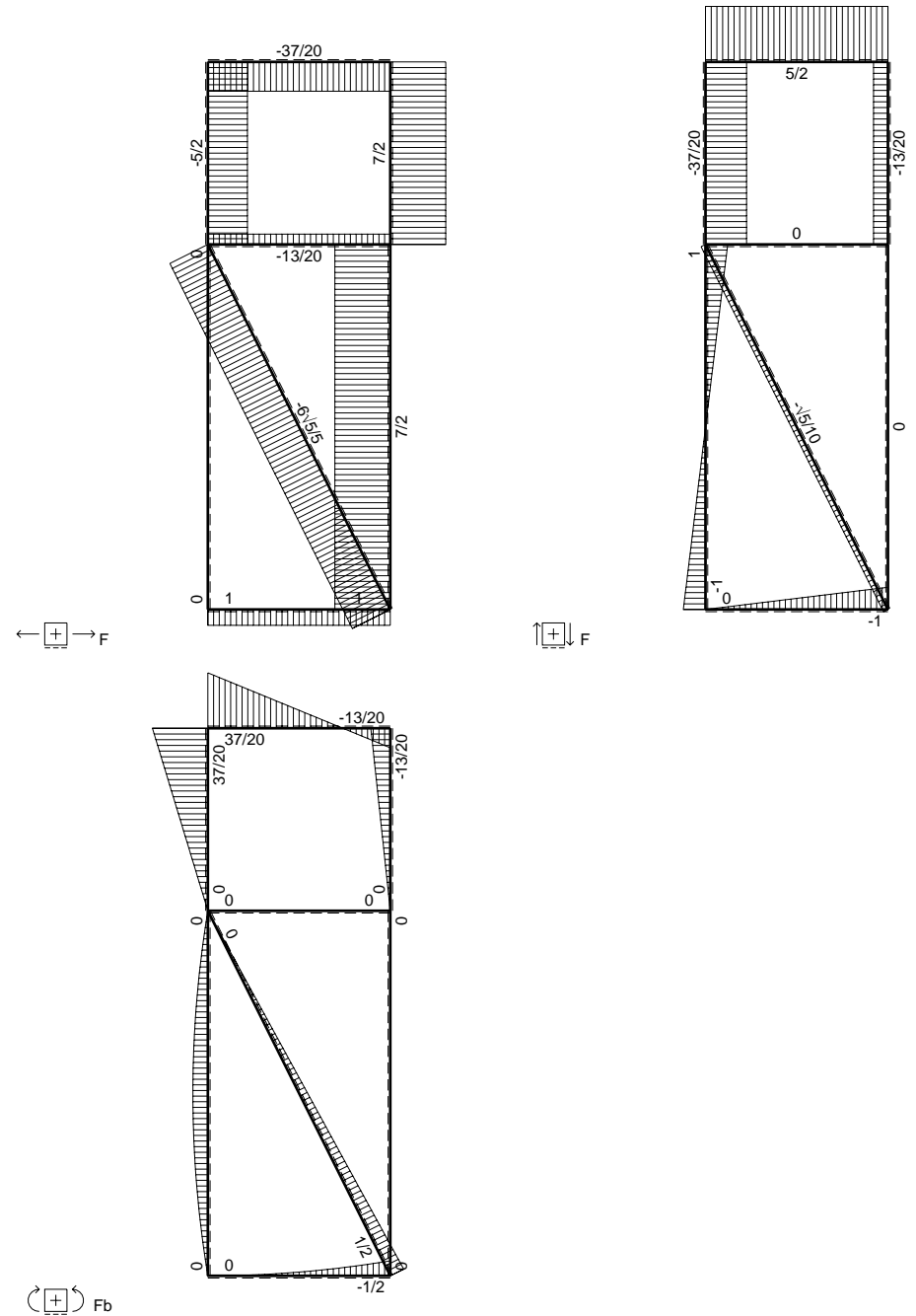
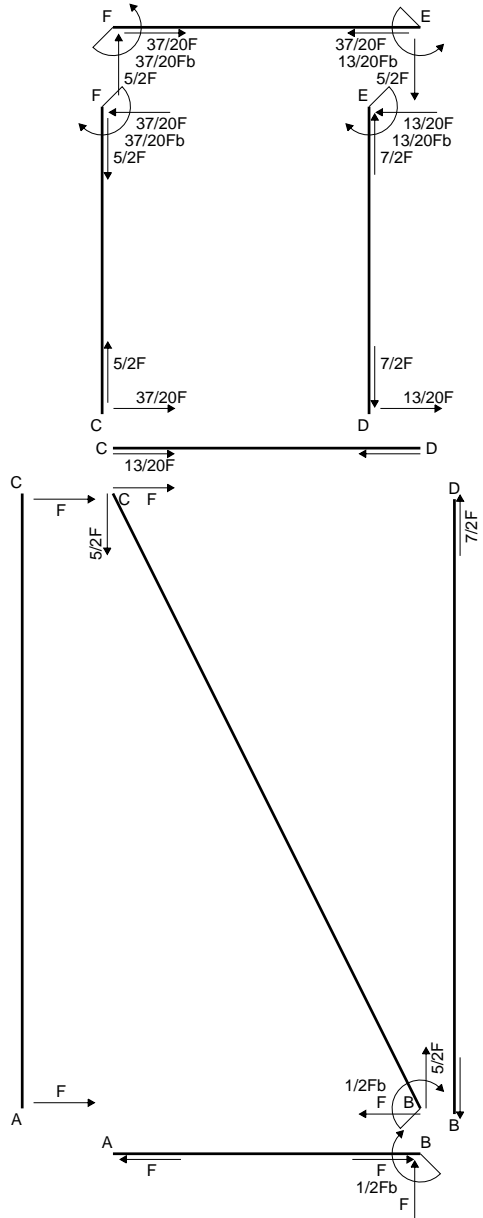

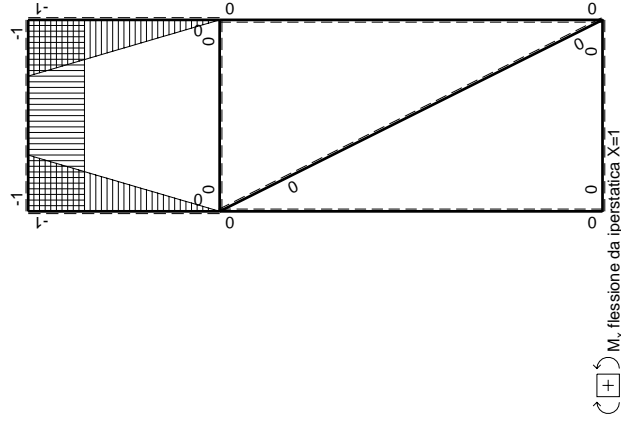
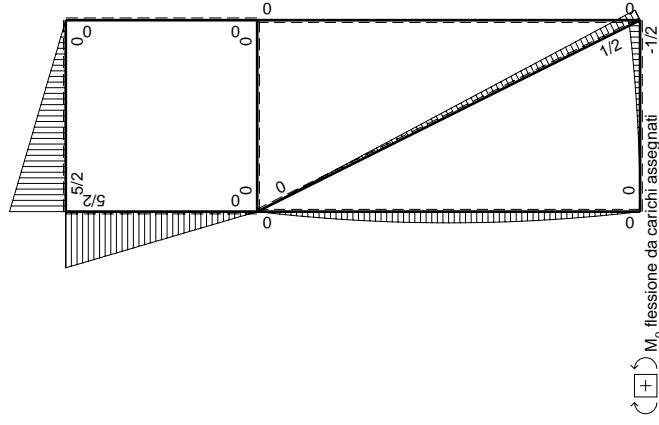
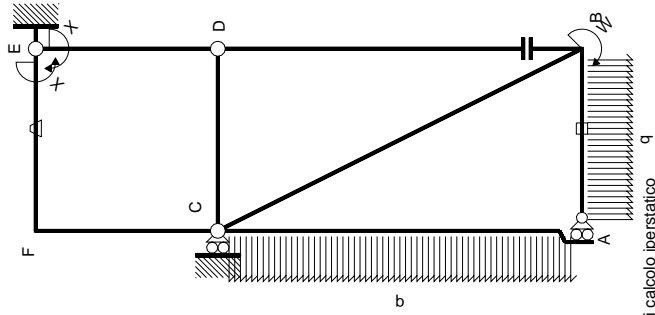

Quadro contributi PLV per iperstatica $X=W_{eff}$

\rightarrow	$M(x)$	$M_0(x)$	θ	M_M^0	M_θ	M_M^x	$\int M_x(M_0/EJ+\theta)dx$	$\int M_x M_x/EJ dx$
AB b	0	$-1/2qx^2$	0	0	0	0	0	0
BA b	0	$1/2Fb-Fx+1/2qx^2$	0	0	0	0	0	0
BC $\sqrt{5}b$	0	$1/2Fb-\sqrt{5}/10Fx$	0	0	0	0	0	0
AC 2b	0	$-Fx+1/2qx^2$	0	0	0	0	0	0
CA 2b	0	$Fx-1/2qx^2$	0	0	0	0	0	0
DB 2b	0	0	0	0	0	0	0	0
BD 2b	0	0	0	0	0	0	0	0
DE b	$-x/b$	0	0	0	0	x^2/b^2	0	0
ED b	$1-x/b$	0	0	0	0	$1-2x/b+x^2/b^2$	0	0
CD b	0	0	0	0	0	0	0	0
DC b	0	0	0	0	0	0	0	0
EF b	-1	$5/2Fx$	$-Fb/EJ$	$-5/2Fx$	Fb/EJ	1	$(-5/4+1)Fb^2/EJ$	Xb/EJ
FE b	1	$-5/2Fb+5/2Fx$	Fb/EJ	$-5/2Fb+5/2Fx$	Fb/EJ	1	$(-5/4+1)Fb^2/EJ$	Xb/EJ
FC b	$-1+x/b$	$5/2Fb-5/2Fx$	0	$-5/2Fb+5Fx-5/2Fx^2/b$	0	$1-2x/b+x^2/b^2$	$(-5/6+0)Fb^2/EJ$	$1/3Xb/EJ$
CF b	x/b	$-5/2Fx$	0	$-5/2Fx^2/b$	0	x^2/b^2	$(-5/6+0)Fb^2/EJ$	$1/3Xb/EJ$
totali							$-13/12Fb^2/EJ$	$5/3Xb/EJ$
								$13/20Fb$

Sviluppi di calcolo iperstatica

$$L_{DE}^{xx} = \int_0^b (x^2/b^2) 1/EJ dx = [1/3 x^3/b^2]_0^b 1/EJ$$

$$= (1/3 b) 1/EJ = 1/3 b/EJ$$

$$L_{ED}^{xx} = \int_0^b (1 - 2x/b + x^2/b^2) 1/EJ dx = [x - x^2/b + 1/3 x^3/b^2]_0^b 1/EJ$$

$$= (b - b + 1/3 b) 1/EJ = 1/3 b/EJ$$

$$L_{EF}^{xx} = \int_0^b (1) 1/EJ dx = [x]_0^b 1/EJ$$

$$= (b) 1/EJ = b/EJ$$

$$L_{FE}^{xx} = \int_0^b (1) 1/EJ dx = [x]_0^b 1/EJ$$

$$= (b) 1/EJ = b/EJ$$

$$L_{FC}^{xx} = \int_0^b (1 - 2x/b + x^2/b^2) 1/EJ dx = [x - x^2/b + 1/3 x^3/b^2]_0^b 1/EJ$$

$$= (b - b + 1/3 b) 1/EJ = 1/3 b/EJ$$

$$L_{CF}^{xx} = \int_0^b (x^2/b^2) 1/EJ dx = [1/3 x^3/b^2]_0^b 1/EJ$$

$$= (1/3 b) 1/EJ = 1/3 b/EJ$$

$$L_{EF}^{xo} = \int_0^b (-5/2 x/b) Fb 1/EJ dx + \int_0^b (1) \theta dx = [-5/4 x^2/b]_0^b Fb 1/EJ + [x]_0^b \theta$$

$$= (-5/4 b) Fb 1/EJ + (b) \theta = -1/4 Fb^2/EJ$$

$$L_{FE}^{xo} = \int_0^b (-5/2 + 5/2 x/b) Fb 1/EJ dx + \int_0^b (-1) \theta dx = [-5/2 x + 5/4 x^2/b]_0^b Fb 1/EJ + [-x]_0^b \theta$$

$$= (-5/2 b + 5/4 b) Fb 1/EJ + (-b) \theta = -1/4 Fb^2/EJ$$

$$L_{FC}^{xo} = \int_0^b (-5/2 + 5x/b - 5/2 x^2/b^2) Fb 1/EJ dx = [-5/2 x + 5/2 x^2/b - 5/6 x^3/b^2]_0^b Fb 1/EJ$$

$$= (-5/2 b + 5/2 b - 5/6 b) Fb 1/EJ = -5/6 Fb^2/EJ$$

$$L_{CF}^{xo} = \int_0^b (-5/2 x^2/b^2) Fb 1/EJ dx = [-5/6 x^3/b^2]_0^b Fb 1/EJ$$

$$= (-5/6 b) Fb 1/EJ = -5/6 Fb^2/EJ$$

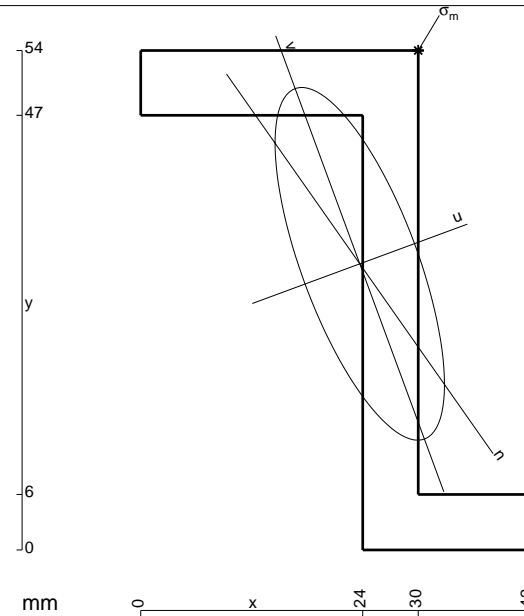

- A = 564. mm²
- J_x = 205146. mm⁴
- J_y = 47319. mm⁴
- J_{xy} = -67404. mm⁴
- J_u = 230014. mm⁴
- J_v = 22451. mm⁴
- α = arctg(2J_{xy}/(J_y-J_x))/2 = .3534
- c = cosα = .9382
- s = sinα = .3461
- x_g = 23.68 mm
- y_g = 30.94 mm
- N = -1525. N
- T_y = -1129. N
- M_x = 767380. Nmm
- x_m = 30. mm
- y_m = 54. mm
- u_m = 13.91 mm
- v_m = 19.45 mm
- σ_m = N/A - Mcv/J_u - Msu/J_v = -228.2 N/mm²

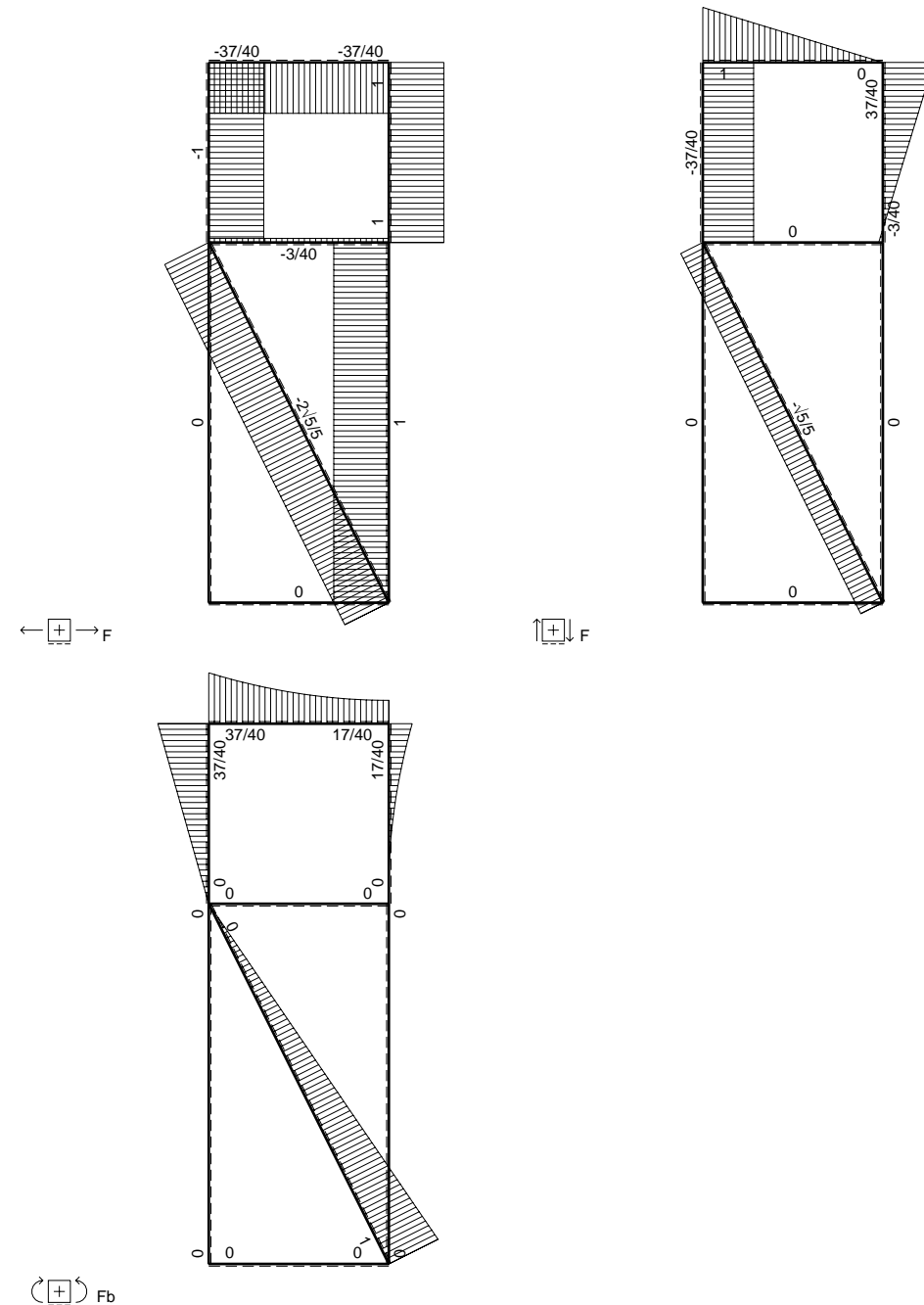
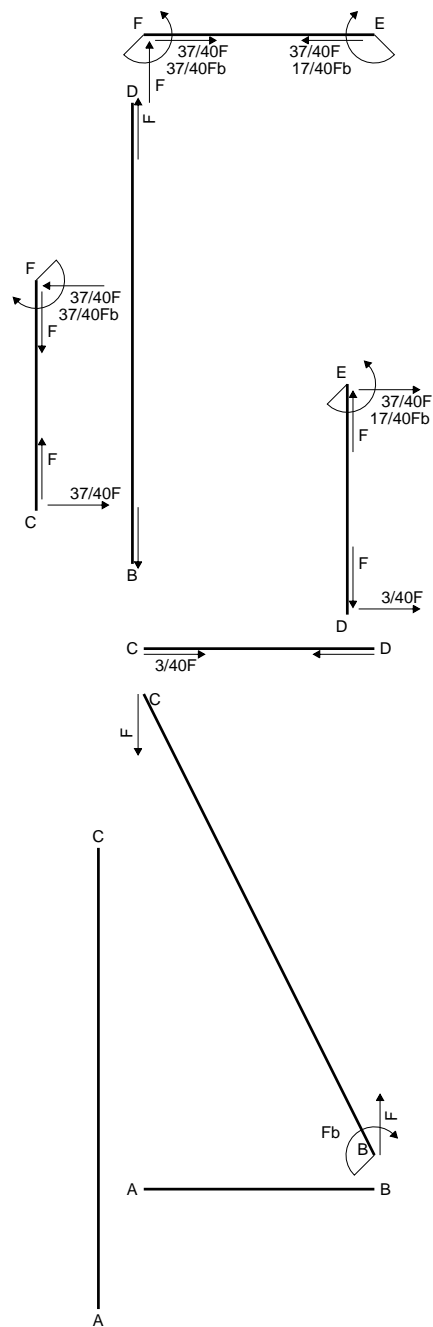

$$L_{DE}^{xx} = \int_0^b (x^2/b^2) 1/EJ dx = [1/3 x^3/b^2]_0^b 1/EJ$$

$$= (1/3 b) 1/EJ = 1/3 b/EJ$$

$$L_{ED}^{xx} = \int_0^b (1 - 2x/b + x^2/b^2) 1/EJ dx = [x - x^2/b + 1/3 x^3/b^2]_0^b 1/EJ$$

$$= (b - b + 1/3 b) 1/EJ = 1/3 b/EJ$$

$$L_{EF}^{xx} = \int_0^b (1) 1/EJ dx = [x]_0^b 1/EJ$$

$$= (b) 1/EJ = b/EJ$$

$$L_{FE}^{xx} = \int_0^b (1) 1/EJ dx = [x]_0^b 1/EJ$$

$$= (b) 1/EJ = b/EJ$$

$$L_{FC}^{xx} = \int_0^b (1 - 2x/b + x^2/b^2) 1/EJ dx = [x - x^2/b + 1/3 x^3/b^2]_0^b 1/EJ$$

$$= (b - b + 1/3 b) 1/EJ = 1/3 b/EJ$$

$$L_{CF}^{xx} = \int_0^b (x^2/b^2) 1/EJ dx = [1/3 x^3/b^2]_0^b 1/EJ$$

$$= (1/3 b) 1/EJ = 1/3 b/EJ$$

$$L_{DE}^{xo} = \int_0^b (1/2 x^2/b^2 - 1/2 x^3/b^3) Fb 1/EJ dx = [1/6 x^3/b^2 - 1/8 x^4/b^3]_0^b Fb 1/EJ$$

$$= (1/6 b - 1/8 b) Fb 1/EJ = 1/24 Fb^2/EJ$$

$$L_{ED}^{xo} = \int_0^b (1/2 x/b - x^2/b^2 + 1/2 x^3/b^3) Fb 1/EJ dx = [1/4 x^2/b - 1/3 x^3/b^2 + 1/8 x^4/b^3]_0^b Fb 1/EJ$$

$$= (1/4 b - 1/3 b + 1/8 b) Fb 1/EJ = 1/24 Fb^2/EJ$$

$$L_{EF}^{xo} = \int_0^b (-1/2 x^2/b^2) Fb 1/EJ dx + \int_0^b (1) \theta dx = [-1/6 x^3/b^2]_0^b Fb 1/EJ + [x]_0^b \theta$$

$$= (-1/6 b) Fb 1/EJ + (b) \theta = 5/6 Fb^2/EJ$$

$$L_{FE}^{xo} = \int_0^b (-1/2 + x/b - 1/2 x^2/b^2) Fb 1/EJ dx + \int_0^b (-1) \theta dx$$

$$= [-1/2 x + 1/2 x^2/b - 1/6 x^3/b^2]_0^b Fb 1/EJ + [-x]_0^b \theta$$

$$= (-1/2 b + 1/2 b - 1/6 b) Fb 1/EJ + (-b) \theta = 5/6 Fb^2/EJ$$

$$L_{FC}^{xo} = \int_0^b (-1/2 + x/b - 1/2 x^2/b^2) Fb 1/EJ dx = [-1/2 x + 1/2 x^2/b - 1/6 x^3/b^2]_0^b Fb 1/EJ$$

$$= (-1/2 b + 1/2 b - 1/6 b) Fb 1/EJ = -1/6 Fb^2/EJ$$

$$L_{CF}^{xo} = \int_0^b (-1/2 x^2/b^2) Fb 1/EJ dx = [-1/6 x^3/b^2]_0^b Fb 1/EJ$$

$$= (-1/6 b) Fb 1/EJ = -1/6 Fb^2/EJ$$

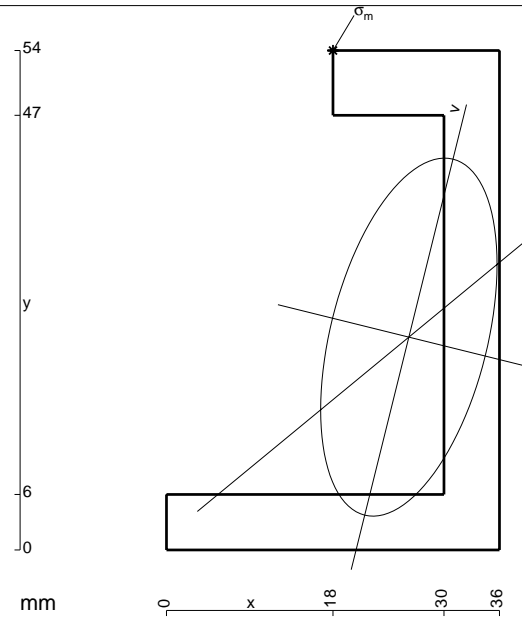

- A = 588. mm²
- J_x = 220324. mm⁴
- J_y = 53448. mm⁴
- J_{xy} = 44051. mm⁴
- J_u = 231238. mm⁴
- J_v = 42533. mm⁴
- α = arctg(2J_{xy}/(J_y-J_x))/2 = -.2429
- c = cos α = .9707
- s = sin α = -.2405
- x_g = 26.2 mm
- y_g = 23.01 mm
- N = -1431. N
- T_y = -715.5 N
- M_x = 1152000. Nmm
- x_m = 18. mm
- y_m = 54. mm
- u_m = -15.42 mm
- v_m = 28.11 mm
- σ_m = N/A - Mc_v/J_u - Ms_u/J_v = -238.8 N/mm²

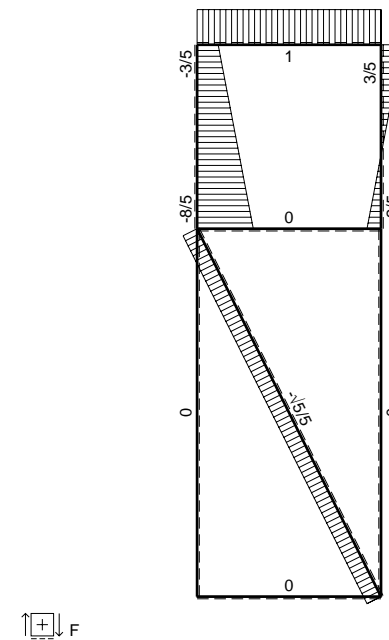
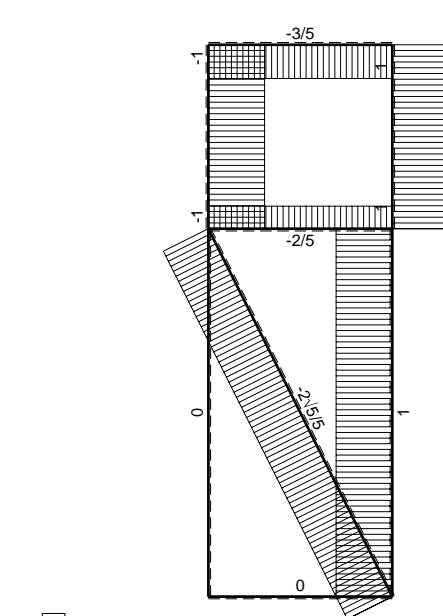
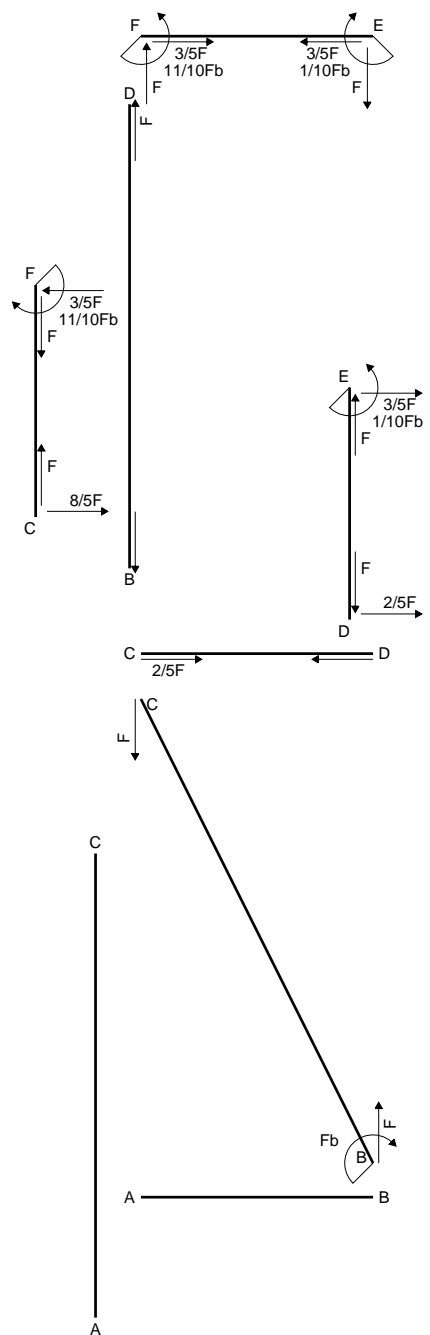

← ⊕ → F

↑ ⊕ ↓ F

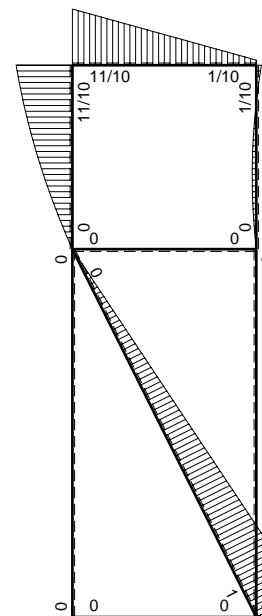

⊕ ↻ F_b

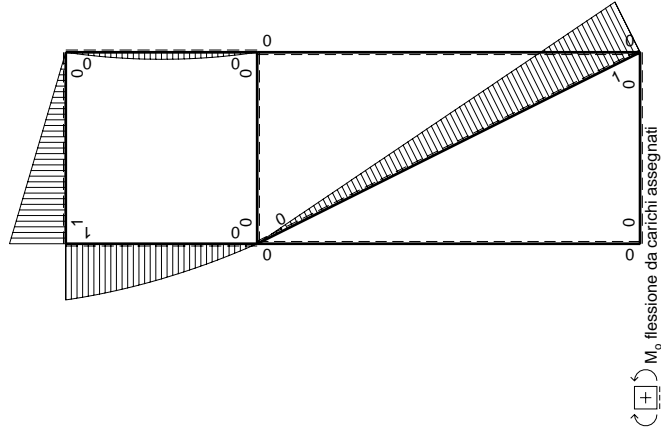
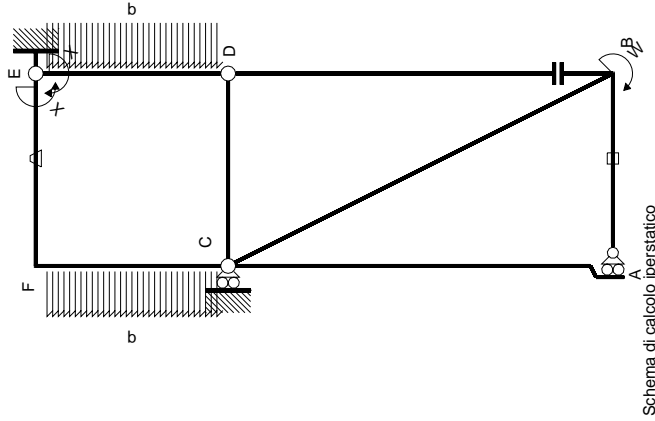

Quadro contributi PLV per iperstatica $X=W_{EF}$

\rightarrow	$M(x)$	$M_0(x)$	θ	$M_x M_0$	$M_x \theta$	$M_x M_x$	$\int M_x(M_0/EJ+\theta)dx$	$\int M_x M_x/EJ dx$
AB b	0	0	0	0	0	0	0+0	0
BA b	0	0	0	0	0	0	0	0
BC $\sqrt{5}b$	$Fb-\sqrt{5}Fx$	0	0	0	0	0	0	0
CA 2b	0	0	0	0	0	0	0+0	0
DB 2b	0	0	0	0	0	0	0+0	0
BD 2b	0	0	0	0	0	0	0+0	0
DE b	$-1/2Fx+1/2qx^2$	$1/2Fx^2/b-1/2qx^3/b$	0	$1/2Fx^2/b-1/2qx^3/b$	0	x^2/b^2	$(1/24+0)Fb^2/EJ$	$1/3Xb/EJ$
ED b	$1/2Fx-1/2qx^2$	$1/2Fx-Fx^2/b+1/2qx^3/b$	0	$1/2Fx-Fx^2/b+1/2qx^3/b$	0	$1-2x/b+x^2/b^2$	$(1/24+0)Fb^2/EJ$	$1/3Xb/EJ$
CD b	0	0	0	0	0	0	0+0	0
FE b	-1	Fx	$-Fb/EJ$	$-Fx$	Fb/EJ	1	$(-1/2+1)Fb^2/EJ$	Xb/EJ
FE b	1	$-Fb+Fx$	Fb/EJ	$-Fb+Fx$	Fb/EJ	1	$(-1/2+1)Fb^2/EJ$	Xb/EJ
FC b	$-1+x/b$	$Fb-1/2Fx-1/2qx^2$	0	$-Fb+3/2Fx-1/2qx^2/b$	0	$1-2x/b+x^2/b^2$	$(-3/8+0)Fb^2/EJ$	$1/3Xb/EJ$
CF b	x/b	$-3/2Fx+1/2qx^2$	0	$-3/2Fx^2/b+1/2qx^3/b$	0	x^2/b^2	$(-3/8+0)Fb^2/EJ$	$1/3Xb/EJ$
totali							$1/6Fb^2/EJ$	$5/3Xb/EJ$
iperstatica $X=W_{EF}$							$-1/10Fb$	

Sviluppi di calcolo iperstatica

$$L_{DE}^{xx} = \int_0^b (x^2/b^2) 1/EJ dx = [1/3 x^3/b^2]_0^b 1/EJ$$

$$= (1/3 b) 1/EJ = 1/3 b/EJ$$

$$L_{ED}^{xx} = \int_0^b (1 - 2x/b + x^2/b^2) 1/EJ dx = [x - x^2/b + 1/3 x^3/b^2]_0^b 1/EJ$$

$$= (b - b + 1/3 b) 1/EJ = 1/3 b/EJ$$

$$L_{EF}^{xx} = \int_0^b (1) 1/EJ dx = [x]_0^b 1/EJ$$

$$= (b) 1/EJ = b/EJ$$

$$L_{FE}^{xx} = \int_0^b (1) 1/EJ dx = [x]_0^b 1/EJ$$

$$= (b) 1/EJ = b/EJ$$

$$L_{FC}^{xx} = \int_0^b (1 - 2x/b + x^2/b^2) 1/EJ dx = [x - x^2/b + 1/3 x^3/b^2]_0^b 1/EJ$$

$$= (b - b + 1/3 b) 1/EJ = 1/3 b/EJ$$

$$L_{CF}^{xx} = \int_0^b (x^2/b^2) 1/EJ dx = [1/3 x^3/b^2]_0^b 1/EJ$$

$$= (1/3 b) 1/EJ = 1/3 b/EJ$$

$$L_{DE}^{xo} = \int_0^b (1/2 x^2/b^2 - 1/2 x^3/b^3) Fb 1/EJ dx = [1/6 x^3/b^2 - 1/8 x^4/b^3]_0^b Fb 1/EJ$$

$$= (1/6 b - 1/8 b) Fb 1/EJ = 1/24 Fb^2/EJ$$

$$L_{ED}^{xo} = \int_0^b (1/2 x/b - x^2/b^2 + 1/2 x^3/b^3) Fb 1/EJ dx = [1/4 x^2/b - 1/3 x^3/b^2 + 1/8 x^4/b^3]_0^b Fb 1/EJ$$

$$= (1/4 b - 1/3 b + 1/8 b) Fb 1/EJ = 1/24 Fb^2/EJ$$

$$L_{EF}^{xo} = \int_0^b (-x/b) Fb 1/EJ dx + \int_0^b (1) \theta dx = [-1/2 x^2/b]_0^b Fb 1/EJ + [x]_0^b \theta$$

$$= (-1/2 b) Fb 1/EJ + (b) \theta = 1/2 Fb^2/EJ$$

$$L_{FE}^{xo} = \int_0^b (-1 + x/b) Fb 1/EJ dx + \int_0^b (-1) \theta dx = [-x + 1/2 x^2/b]_0^b Fb 1/EJ + [-x]_0^b \theta$$

$$= (-b + 1/2 b) Fb 1/EJ + (-b) \theta = 1/2 Fb^2/EJ$$

$$L_{FC}^{xo} = \int_0^b (-1 + 3/2 x/b - 1/2 x^3/b^3) Fb 1/EJ dx = [-x + 3/4 x^2/b - 1/8 x^4/b^3]_0^b Fb 1/EJ$$

$$= (-b + 3/4 b - 1/8 b) Fb 1/EJ = -3/8 Fb^2/EJ$$

$$L_{CF}^{xo} = \int_0^b (-3/2 x^2/b^2 + 1/2 x^3/b^3) Fb 1/EJ dx = [-1/2 x^3/b^2 + 1/8 x^4/b^3]_0^b Fb 1/EJ$$

$$= (-1/2 b + 1/8 b) Fb 1/EJ = -3/8 Fb^2/EJ$$

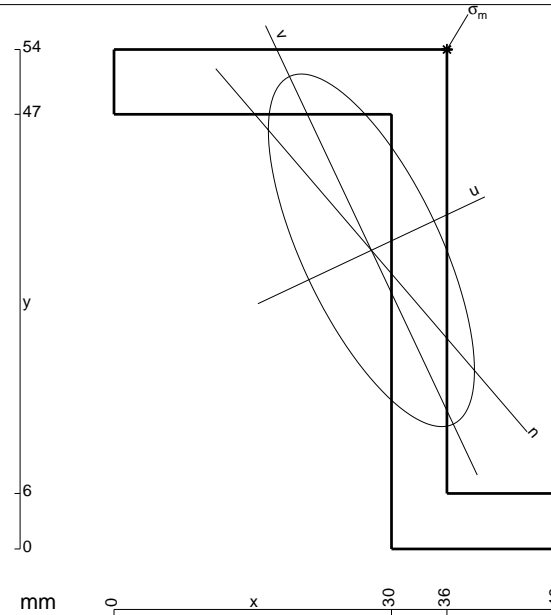

- A = 606. mm²
- J_x = 220278. mm⁴
- J_y = 75271. mm⁴
- J_{xy} = -87807. mm⁴
- J_u = 261647. mm⁴
- J_v = 33902. mm⁴
- α = arctg(2J_{xy}/(J_y-J_x))/2 = .4403
- c = cos α = .9046
- s = sin α = .4262
- x_g = 27.83 mm
- y_g = 32.29 mm
- N = -1770. N
- T_y = -1062. N
- M_x = 739860. Nmm
- x_m = 36. mm
- y_m = 54. mm
- u_m = 16.64 mm
- v_m = 16.16 mm
- σ_m = N/A - Mcv/J_u - Msu/J_v = -199. N/mm²

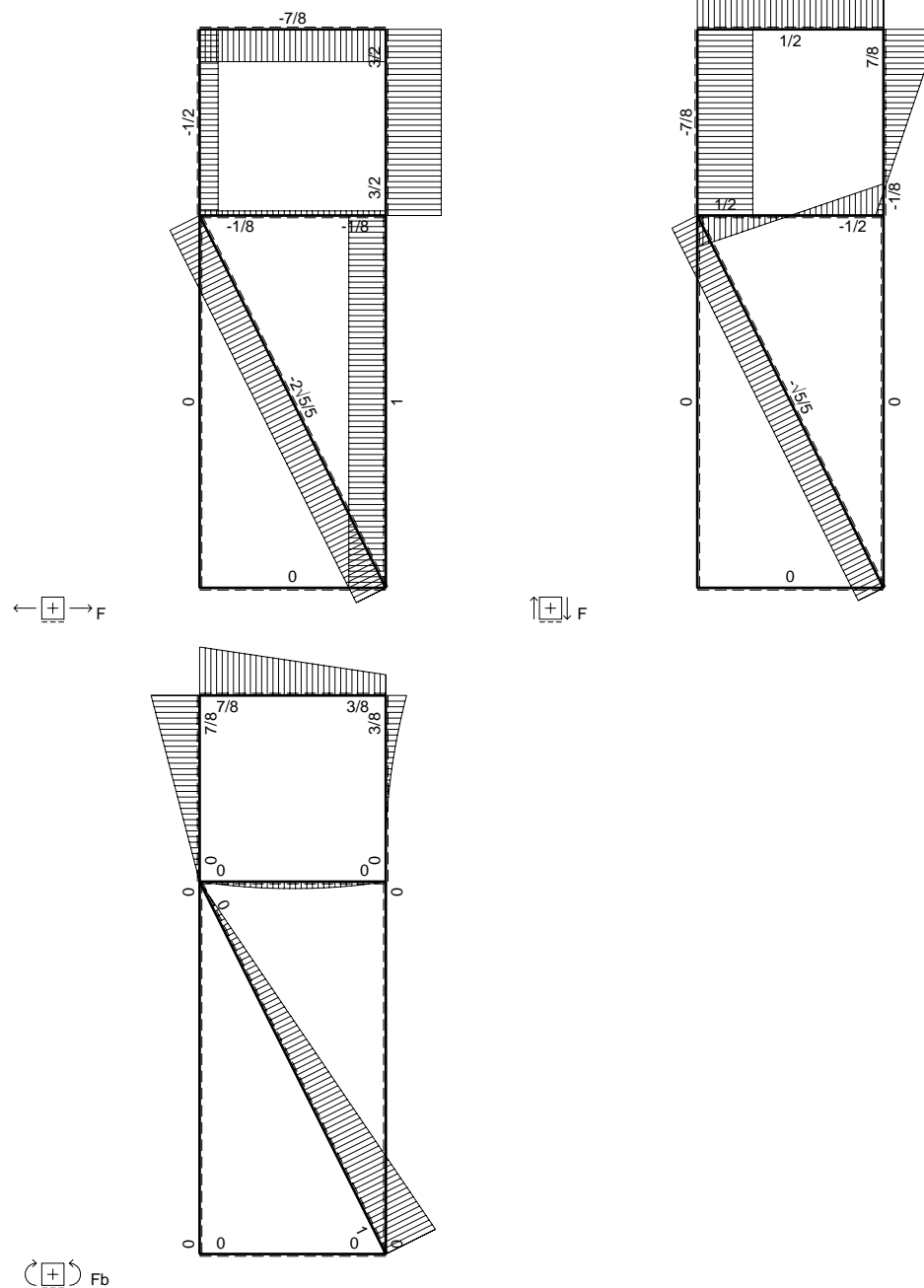
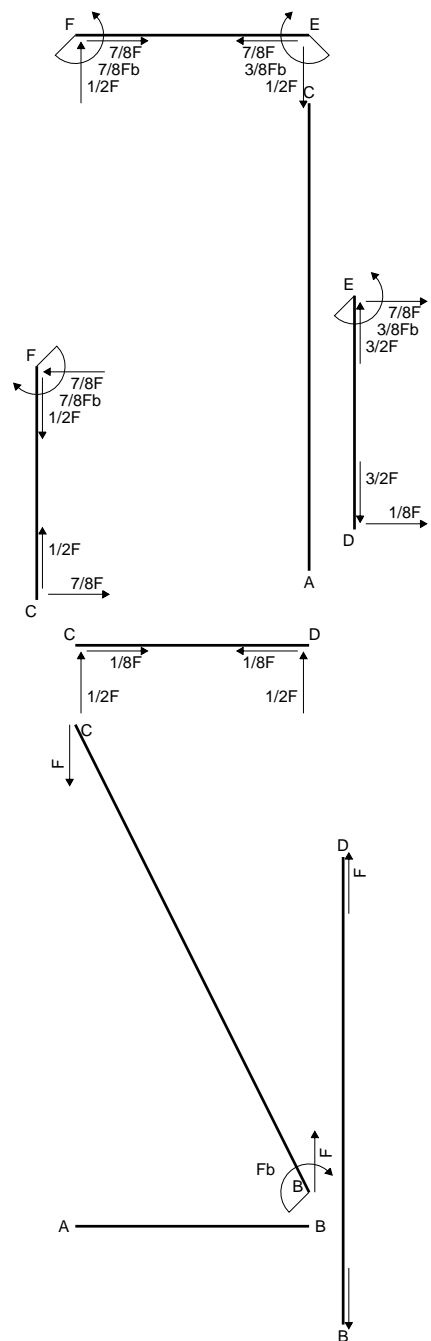

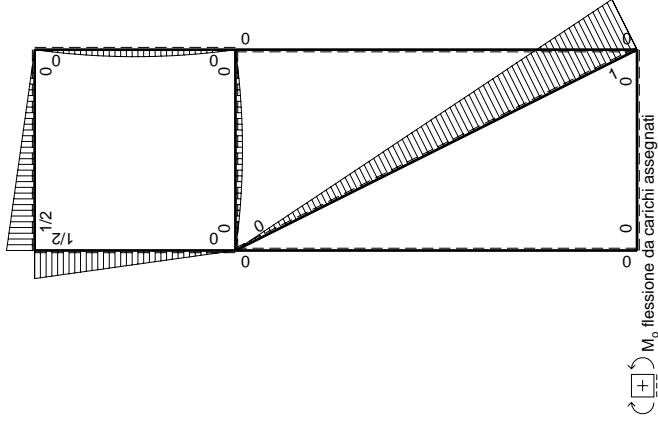
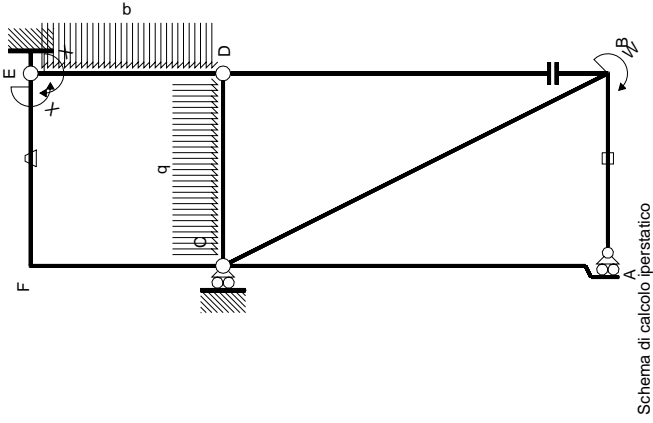

M_x flessione da iperstatica $X=1$

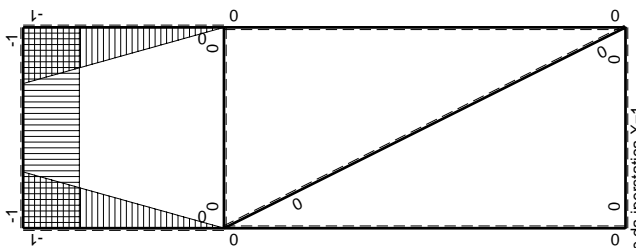

Quadro contributi PLV per iperstatica $X=W_{EF}$

\leftarrow	$M^x(x)$	$M^0(x)$	θ	$M^x M_0$	$M^x \theta$	$M^x M_x$	$\int M^x (M_0/EJ + \theta) dx$	$\int M^x M_x / E J dx$
AB b	0	0	0	0	0	0	0+0	0
BA b	0	0	0	0	0	0	0	0
BC $\sqrt{5}b$	0	$Fb\sqrt{5}/5Fx$	0	0	0	0	0+0	0
CA 2b	0	0	0	0	0	0	0+0	0
DB 2b	0	0	0	0	0	0	0+0	0
BD 2b	0	0	0	0	0	0	0+0	0
DE b	$-x/b$	$-1/2Fx + 1/2qx^2$	0	$1/2Fx^2/b - 1/2qx^3/b$	0	0	x^2/b^2	$1/3Xb/EJ$
ED b	$1-x/b$	$1/2Fx - 1/2qx^2$	0	$1/2Fx - Fx^2/b + 1/2qx^3/b$	0	0	$1-2x/b+x^2/b^2$	$1/3Xb/EJ$
CD b	0	$1/2Fx - 1/2qx^2$	0	0	0	0	0	0
DC b	0	$-1/2Fx + 1/2qx^2$	0	0	0	0	0+0	0
EF b	-1	$1/2Fx$	$-Fb/EJ$	$-1/2Fx$	Fb/EJ	1	$(-1/4+1)Fb^2/EJ$	Xb/EJ
FE b	1	$-1/2Fb + 1/2Fx$	Fb/EJ	$-1/2Fb + 1/2Fx$	Fb/EJ	1	$(-1/4+1)Fb^2/EJ$	Xb/EJ
FC b	$-1+x/b$	$1/2Fb - 1/2Fx$	0	$-1/2Fb + Fx - 1/2Fx^2/b$	0	0	$1-2x/b+x^2/b^2$	$1/3Xb/EJ$
CF b	x/b	$-1/2Fx$	0	$-1/2Fx^2/b$	0	0	x^2/b^2	$1/3Xb/EJ$
totali								$5/8Fb^2/EJ$
								$5/3Xb/EJ$
								$-3/8Fb$

Sviluppi di calcolo iperstatica

$$L_{DE}^{xx} = \int_0^b (x^2/b^2) 1/EJ dx = [1/3 x^3/b^2]_0^b 1/EJ$$

$$= (1/3 b) 1/EJ = 1/3 b/EJ$$

$$L_{ED}^{xx} = \int_0^b (1 - 2x/b + x^2/b^2) 1/EJ dx = [x - x^2/b + 1/3 x^3/b^2]_0^b 1/EJ$$

$$= (b - b + 1/3 b) 1/EJ = 1/3 b/EJ$$

$$L_{EF}^{xx} = \int_0^b (1) 1/EJ dx = [x]_0^b 1/EJ$$

$$= (b) 1/EJ = b/EJ$$

$$L_{FE}^{xx} = \int_0^b (1) 1/EJ dx = [x]_0^b 1/EJ$$

$$= (b) 1/EJ = b/EJ$$

$$L_{FC}^{xx} = \int_0^b (1 - 2x/b + x^2/b^2) 1/EJ dx = [x - x^2/b + 1/3 x^3/b^2]_0^b 1/EJ$$

$$= (b - b + 1/3 b) 1/EJ = 1/3 b/EJ$$

$$L_{CF}^{xx} = \int_0^b (x^2/b^2) 1/EJ dx = [1/3 x^3/b^2]_0^b 1/EJ$$

$$= (1/3 b) 1/EJ = 1/3 b/EJ$$

$$L_{DE}^{xo} = \int_0^b (1/2 x^2/b^2 - 1/2 x^3/b^3) Fb 1/EJ dx = [1/6 x^3/b^2 - 1/8 x^4/b^3]_0^b Fb 1/EJ$$

$$= (1/6 b - 1/8 b) Fb 1/EJ = 1/24 Fb^2/EJ$$

$$L_{ED}^{xo} = \int_0^b (1/2 x/b - x^2/b^2 + 1/2 x^3/b^3) Fb 1/EJ dx = [1/4 x^2/b - 1/3 x^3/b^2 + 1/8 x^4/b^3]_0^b Fb 1/EJ$$

$$= (1/4 b - 1/3 b + 1/8 b) Fb 1/EJ = 1/24 Fb^2/EJ$$

$$L_{EF}^{xo} = \int_0^b (-1/2 x/b) Fb 1/EJ dx + \int_0^b (1) \theta dx = [-1/4 x^2/b]_0^b Fb 1/EJ + [x]_0^b \theta$$

$$= (-1/4 b) Fb 1/EJ + (b) \theta = 3/4 Fb^2/EJ$$

$$L_{FE}^{xo} = \int_0^b (-1/2 + 1/2 x/b) Fb 1/EJ dx + \int_0^b (-1) \theta dx = [-1/2 x + 1/4 x^2/b]_0^b Fb 1/EJ + [-x]_0^b \theta$$

$$= (-1/2 b + 1/4 b) Fb 1/EJ + (-b) \theta = 3/4 Fb^2/EJ$$

$$L_{FC}^{xo} = \int_0^b (-1/2 + x/b - 1/2 x^2/b^2) Fb 1/EJ dx = [-1/2 x + 1/2 x^2/b - 1/6 x^3/b^2]_0^b Fb 1/EJ$$

$$= (-1/2 b + 1/2 b - 1/6 b) Fb 1/EJ = -1/6 Fb^2/EJ$$

$$L_{CF}^{xo} = \int_0^b (-1/2 x^2/b^2) Fb 1/EJ dx = [-1/6 x^3/b^2]_0^b Fb 1/EJ$$

$$= (-1/6 b) Fb 1/EJ = -1/6 Fb^2/EJ$$

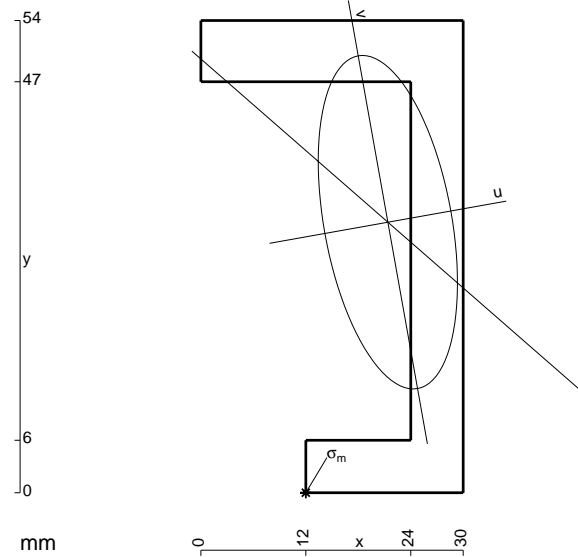

- A = 564. mm²
- J_x = 205146. mm⁴
- J_y = 35737. mm⁴
- J_{xy} = -31198. mm⁴
- J_u = 210708. mm⁴
- J_v = 30175. mm⁴
- α = arctg(2J_{xy}/(J_y-J_x))/2 = .1765
- c = cosα = .9845
- s = sinα = .1755
- x_g = 21.38 mm
- y_g = 30.94 mm
- N = -2120. N
- T_y = -1060. N
- M_x = 971700. Nmm
- x_m = 12. mm
- u_m = -14.67 mm
- v_m = -28.81 mm
- σ_m = N/A - Mcv/J_u - Msu/J_v = 209.9 N/mm²

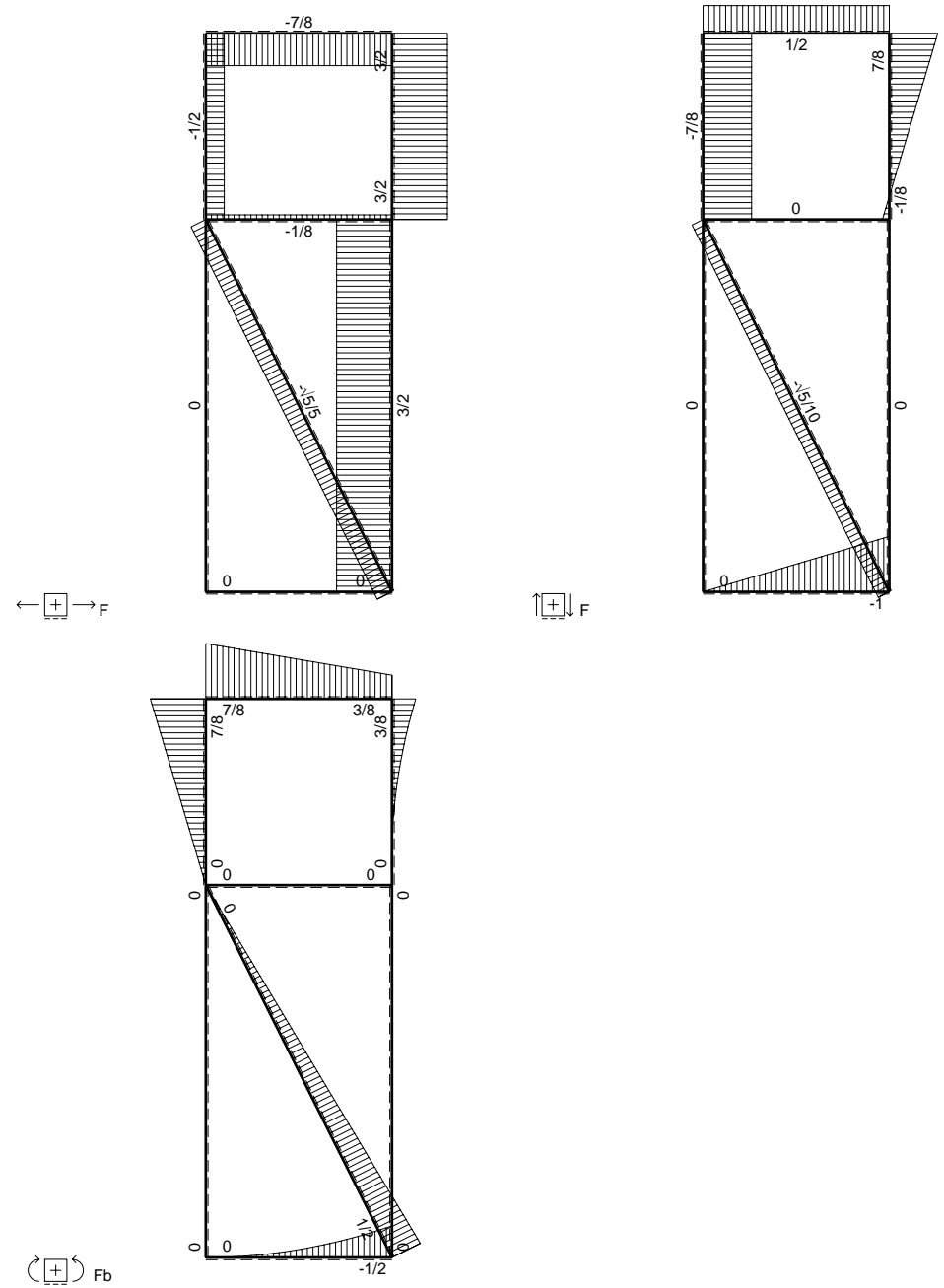
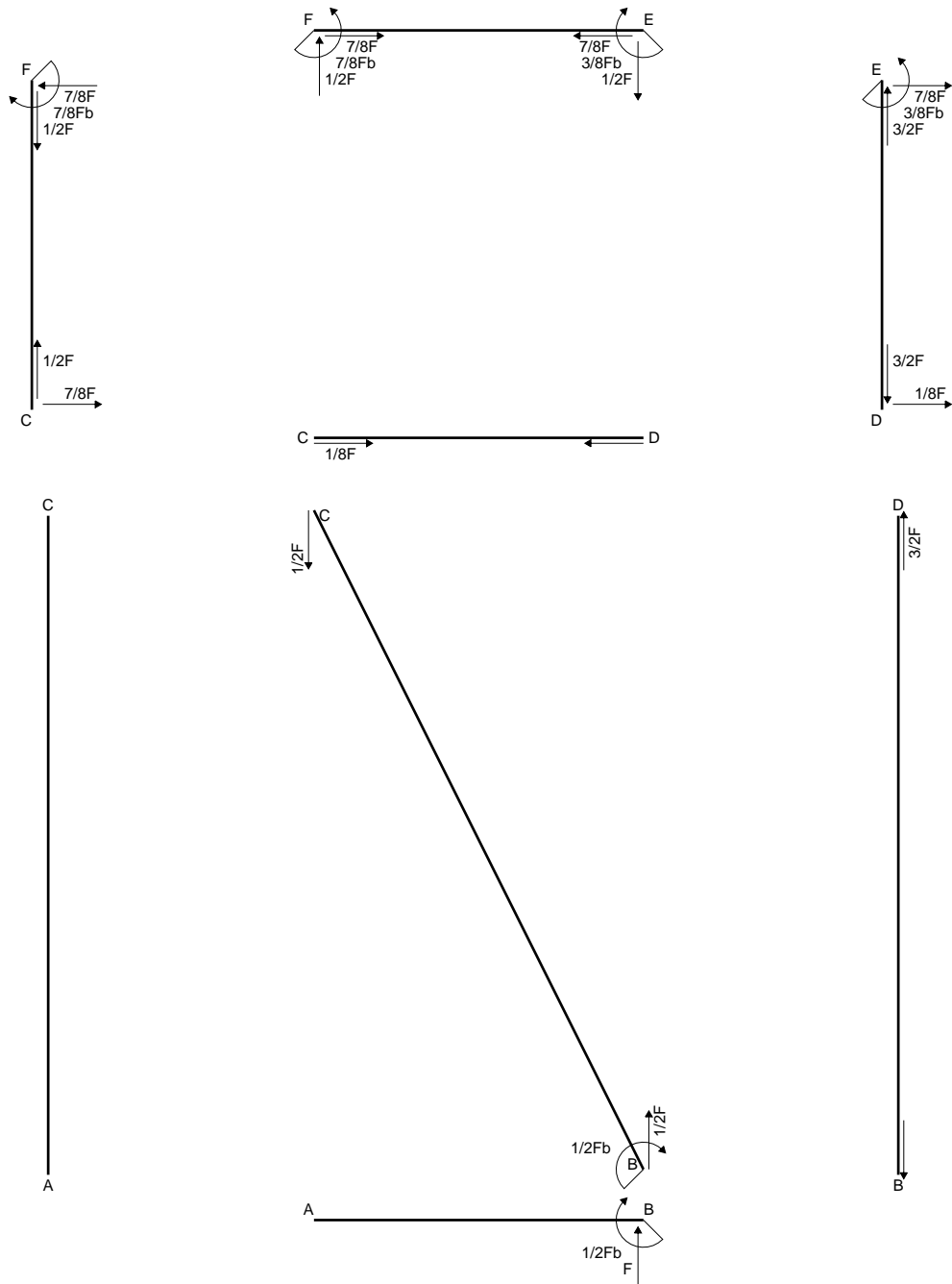

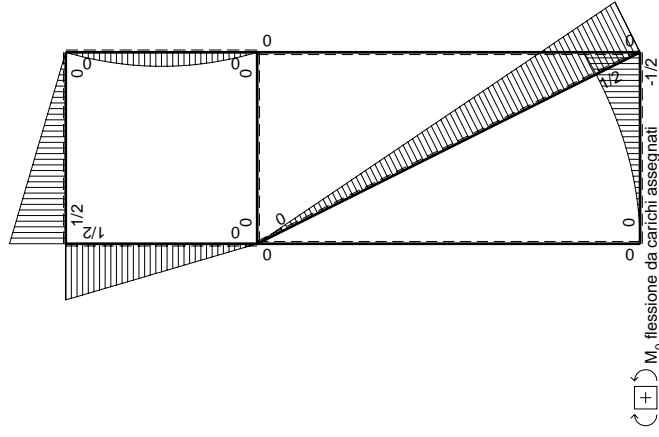
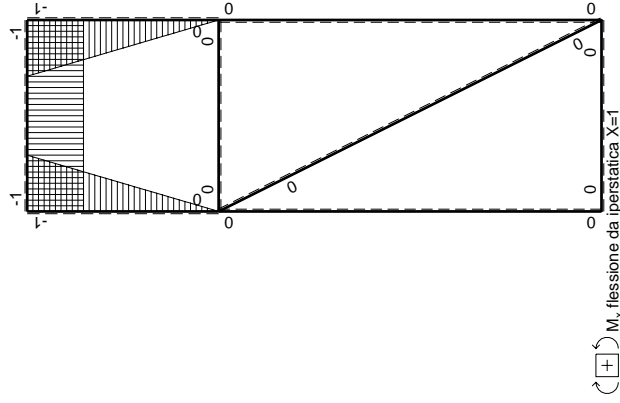
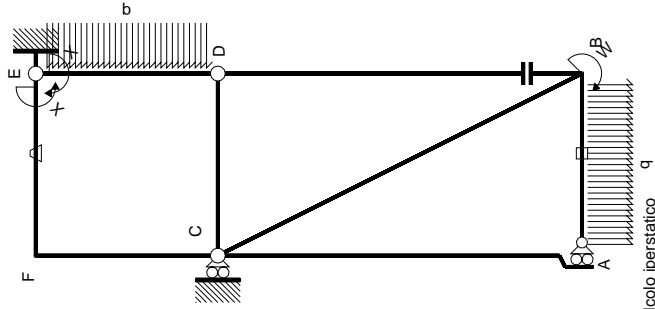

Quadro contributi PLV per iperstatica $X=W_{EF}$

\rightarrow	$M^k(x)$	$M^0(x)$	θ	$M^x M_0$	$M^x \theta$	$M^x M_x$	$\int M^x (M_0/EJ + \theta) dx$	$\int M^x M_x / EJ dx$
AB B	0	$-1/2qx^2$	0	0	0	0	0+0	0
BA B	0	$1/2Fb-Fx+1/2qx^2$	0	0	0	0	0	0
BC $\sqrt{5}b$	0	$1/2Fb-\sqrt{5}/10Fx$	0	0	0	0	0+0	0
CA 2b	0	0	0	0	0	0	0+0	0
DB 2b	0	0	0	0	0	0	0+0	0
BD 2b	0	0	0	0	0	0	0+0	0
DE B	$-x/b$	$-1/2Fx+1/2qx^2$	0	$1/2F^2x^2/b-1/2qx^3/b$	0	0	x^2/b^2	0
ED B	$1-x/b$	$1/2Fx-1/2qx^2$	0	$1/2Fx-Fx^2/b+1/2qx^3/b$	0	0	$1-2x/b+x^2/b^2$	$1/3xb/EJ$
CD B	0	0	0	0	0	0	0+0	0
DC B	0	0	0	0	0	0	0+0	0
EF B	-1	$1/2Fx$	$-Fb/EJ$	$-1/2Fx$	Fb/EJ	1	$(-1/4+1)Fb^2/EJ$	xb/EJ
FE B	1	$-1/2Fb+1/2Fx$	Fb/EJ	$-1/2Fb+1/2Fx$	Fb/EJ	1	$(-1/4+1)Fb^2/EJ$	xb/EJ
FC B	$-1+x/b$	$1/2Fb-1/2Fx$	0	$-1/2Fb+Fx-1/2Fx^2/b$	0	0	$1-2x/b+x^2/b^2$	$1/3xb/EJ$
CF B	x/b	$-1/2Fx$	0	$-1/2Fx^2/b$	0	0	x^2/b^2	$1/3xb/EJ$
totali								$5/8Fb^2/EJ$
								$-3/8Fb$

Sviluppi di calcolo iperstatica

$$L_{DE}^{xx} = \int_0^b (x^2/b^2) 1/EJ dx = [1/3 x^3/b^2]_0^b 1/EJ$$

$$= (1/3 b) 1/EJ = 1/3 b/EJ$$

$$L_{ED}^{xx} = \int_0^b (1 - 2x/b + x^2/b^2) 1/EJ dx = [x - x^2/b + 1/3 x^3/b^2]_0^b 1/EJ$$

$$= (b - b + 1/3 b) 1/EJ = 1/3 b/EJ$$

$$L_{EF}^{xx} = \int_0^b (1) 1/EJ dx = [x]_0^b 1/EJ$$

$$= (b) 1/EJ = b/EJ$$

$$L_{FE}^{xx} = \int_0^b (1) 1/EJ dx = [x]_0^b 1/EJ$$

$$= (b) 1/EJ = b/EJ$$

$$L_{FC}^{xx} = \int_0^b (1 - 2x/b + x^2/b^2) 1/EJ dx = [x - x^2/b + 1/3 x^3/b^2]_0^b 1/EJ$$

$$= (b - b + 1/3 b) 1/EJ = 1/3 b/EJ$$

$$L_{CF}^{xx} = \int_0^b (x^2/b^2) 1/EJ dx = [1/3 x^3/b^2]_0^b 1/EJ$$

$$= (1/3 b) 1/EJ = 1/3 b/EJ$$

$$L_{DE}^{xo} = \int_0^b (1/2 x^2/b^2 - 1/2 x^3/b^3) Fb 1/EJ dx = [1/6 x^3/b^2 - 1/8 x^4/b^3]_0^b Fb 1/EJ$$

$$= (1/6 b - 1/8 b) Fb 1/EJ = 1/24 Fb^2/EJ$$

$$L_{ED}^{xo} = \int_0^b (1/2 x/b - x^2/b^2 + 1/2 x^3/b^3) Fb 1/EJ dx = [1/4 x^2/b - 1/3 x^3/b^2 + 1/8 x^4/b^3]_0^b Fb 1/EJ$$

$$= (1/4 b - 1/3 b + 1/8 b) Fb 1/EJ = 1/24 Fb^2/EJ$$

$$L_{EF}^{xo} = \int_0^b (-1/2 x/b) Fb 1/EJ dx + \int_0^b (1) \theta dx = [-1/4 x^2/b]_0^b Fb 1/EJ + [x]_0^b \theta$$

$$= (-1/4 b) Fb 1/EJ + (b) \theta = 3/4 Fb^2/EJ$$

$$L_{FE}^{xo} = \int_0^b (-1/2 + 1/2 x/b) Fb 1/EJ dx + \int_0^b (-1) \theta dx = [-1/2 x + 1/4 x^2/b]_0^b Fb 1/EJ + [-x]_0^b \theta$$

$$= (-1/2 b + 1/4 b) Fb 1/EJ + (-b) \theta = 3/4 Fb^2/EJ$$

$$L_{FC}^{xo} = \int_0^b (-1/2 + x/b - 1/2 x^2/b^2) Fb 1/EJ dx = [-1/2 x + 1/2 x^2/b - 1/6 x^3/b^2]_0^b Fb 1/EJ$$

$$= (-1/2 b + 1/2 b - 1/6 b) Fb 1/EJ = -1/6 Fb^2/EJ$$

$$L_{CF}^{xo} = \int_0^b (-1/2 x^2/b^2) Fb 1/EJ dx = [-1/6 x^3/b^2]_0^b Fb 1/EJ$$

$$= (-1/6 b) Fb 1/EJ = -1/6 Fb^2/EJ$$

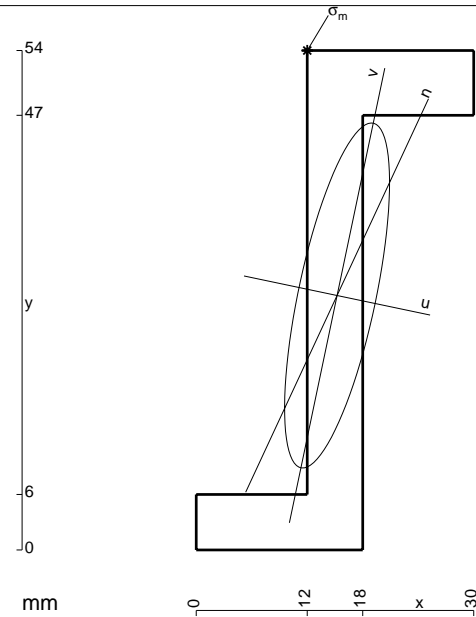

- A = 480. mm²
- J_x = 167026. mm⁴
- J_y = 15456. mm⁴
- J_{xy} = 33263. mm⁴
- J_u = 174004. mm⁴
- J_v = 8477. mm⁴
- α = arctg(2J_{xy}/(J_y-J_x))/2 = -2.068
- c = cos α = .9787
- s = sin α = -.2053
- x_g = 15.23 mm
- y_g = 27.51 mm
- N = -1374. N
- T_y = 785. N
- M_x = 618188. Nmm
- x_m = 12. mm
- y_m = 54. mm
- u_m = -8.595 mm
- v_m = 25.26 mm
- σ_m = N/A - Mcv/J_v - Msu/J_u = -219.4 N/mm²

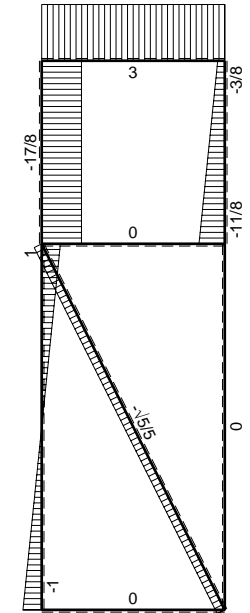
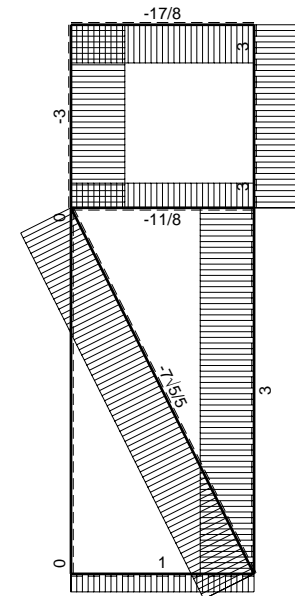
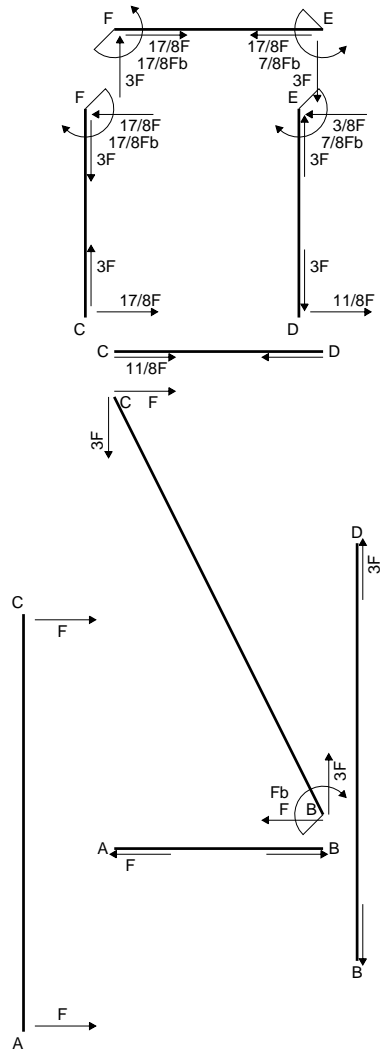

← ⊕ → F

↑ ⊕ ↓ F

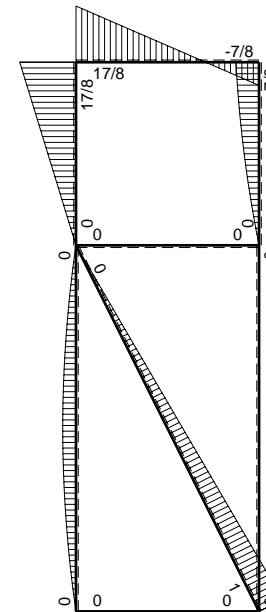

⊕ ⊖ F_b

$$L_{DE}^{xx} = \int_0^b (x^2/b^2) 1/EJ dx = [1/3 x^3/b^2]_0^b 1/EJ$$

$$= (1/3 b) 1/EJ = 1/3 b/EJ$$

$$L_{ED}^{xx} = \int_0^b (1 - 2x/b + x^2/b^2) 1/EJ dx = [x - x^2/b + 1/3 x^3/b^2]_0^b 1/EJ$$

$$= (b - b + 1/3 b) 1/EJ = 1/3 b/EJ$$

$$L_{EF}^{xx} = \int_0^b (1) 1/EJ dx = [x]_0^b 1/EJ$$

$$= (b) 1/EJ = b/EJ$$

$$L_{FE}^{xx} = \int_0^b (1) 1/EJ dx = [x]_0^b 1/EJ$$

$$= (b) 1/EJ = b/EJ$$

$$L_{FC}^{xx} = \int_0^b (1 - 2x/b + x^2/b^2) 1/EJ dx = [x - x^2/b + 1/3 x^3/b^2]_0^b 1/EJ$$

$$= (b - b + 1/3 b) 1/EJ = 1/3 b/EJ$$

$$L_{CF}^{xx} = \int_0^b (x^2/b^2) 1/EJ dx = [1/3 x^3/b^2]_0^b 1/EJ$$

$$= (1/3 b) 1/EJ = 1/3 b/EJ$$

$$L_{DE}^{xo} = \int_0^b (1/2 x^2/b^2 - 1/2 x^3/b^3) Fb 1/EJ dx = [1/6 x^3/b^2 - 1/8 x^4/b^3]_0^b Fb 1/EJ$$

$$= (1/6 b - 1/8 b) Fb 1/EJ = 1/24 Fb^2/EJ$$

$$L_{ED}^{xo} = \int_0^b (1/2 x/b - x^2/b^2 + 1/2 x^3/b^3) Fb 1/EJ dx = [1/4 x^2/b - 1/3 x^3/b^2 + 1/8 x^4/b^3]_0^b Fb 1/EJ$$

$$= (1/4 b - 1/3 b + 1/8 b) Fb 1/EJ = 1/24 Fb^2/EJ$$

$$L_{EF}^{xo} = \int_0^b (-3x/b) Fb 1/EJ dx + \int_0^b (1) \theta dx = [-3/2 x^2/b]_0^b Fb 1/EJ + [x]_0^b \theta$$

$$= (-3/2 b) Fb 1/EJ + (b) \theta = -1/2 Fb^2/EJ$$

$$L_{FE}^{xo} = \int_0^b (-3 + 3x/b) Fb 1/EJ dx + \int_0^b (-1) \theta dx = [-3x + 3/2 x^2/b]_0^b Fb 1/EJ + [-x]_0^b \theta$$

$$= (-3b + 3/2 b) Fb 1/EJ + (-b) \theta = -1/2 Fb^2/EJ$$

$$L_{FC}^{xo} = \int_0^b (-3 + 6x/b - 3x^2/b^2) Fb 1/EJ dx = [-3x + 3x^2/b - x^3/b^2]_0^b Fb 1/EJ$$

$$= (-3b + 3b - b) Fb 1/EJ = - Fb^2/EJ$$

$$L_{CF}^{xo} = \int_0^b (-3x^2/b^2) Fb 1/EJ dx = [-x^3/b^2]_0^b Fb 1/EJ$$

$$= (-b) Fb 1/EJ = - Fb^2/EJ$$

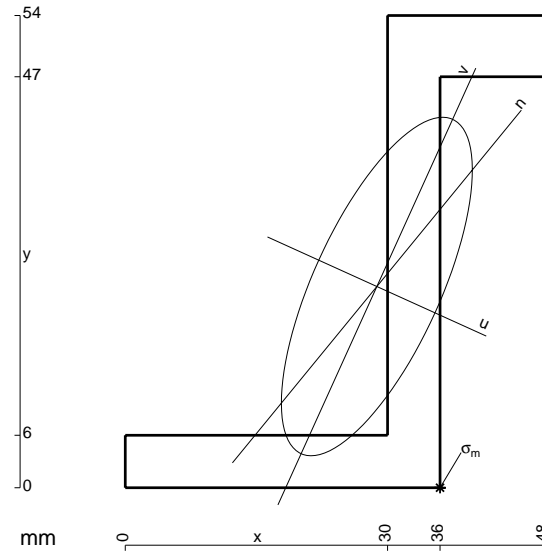

- A = 588. mm²
- J_x = 220324. mm⁴
- J_y = 70110. mm⁴
- J_{xy} = 85615. mm⁴
- J_u = 259108. mm⁴
- J_v = 31327. mm⁴
- α = artg(2J_{xy}/(J_y-J_x))/2 = -.4253
- c = cosα = .9109
- s = sinα = -.4126
- x_g = 28.78 mm
- y_g = 23.01 mm
- N = -1721. N
- T_y = 2430. N
- M_x = 843413. Nmm
- x_m = 36. mm
- u_m = 16.08 mm
- v_m = -17.98 mm
- σ_m = N/A-Mcv/J_u-Msv/J_v = 229. N/mm²

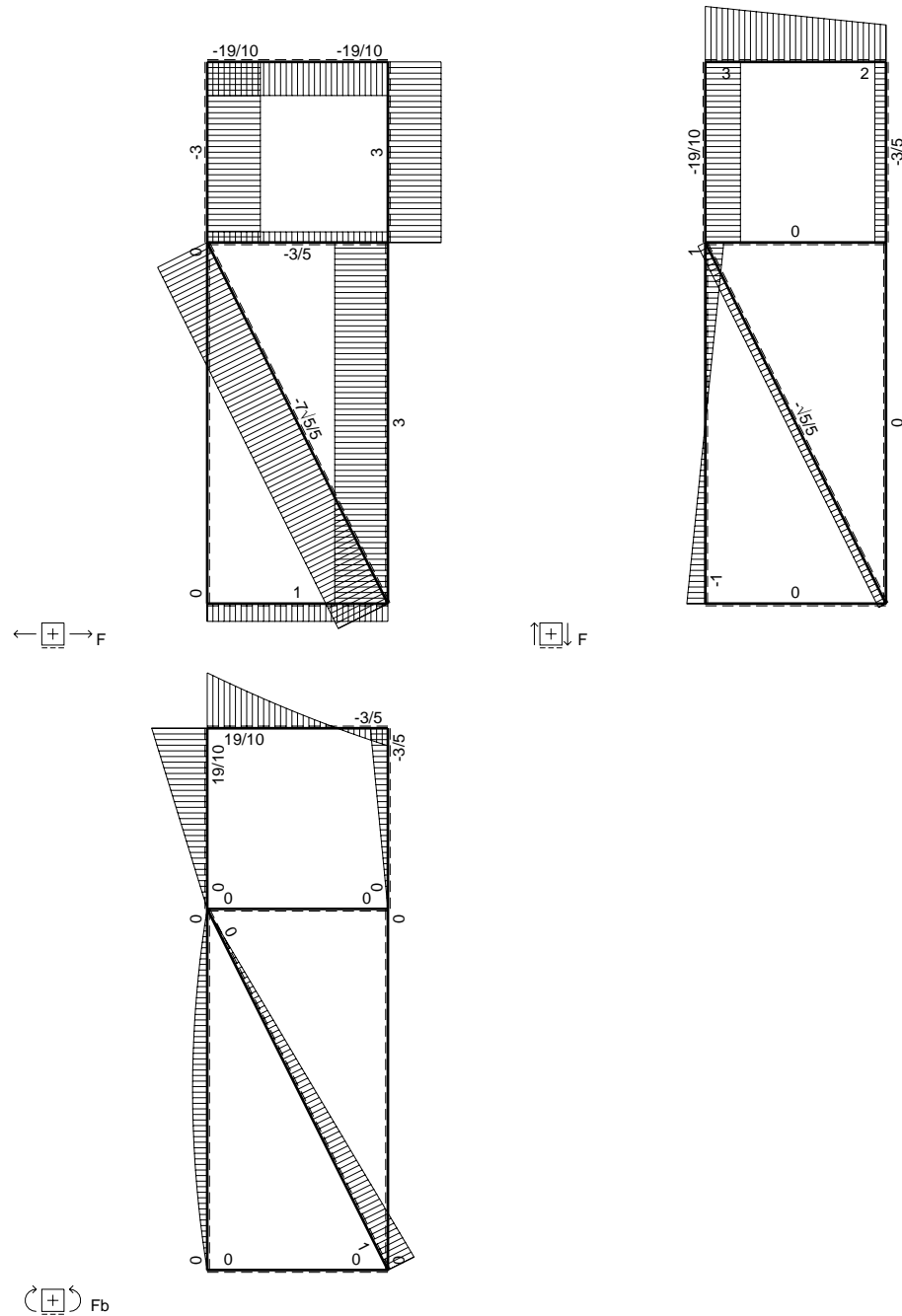
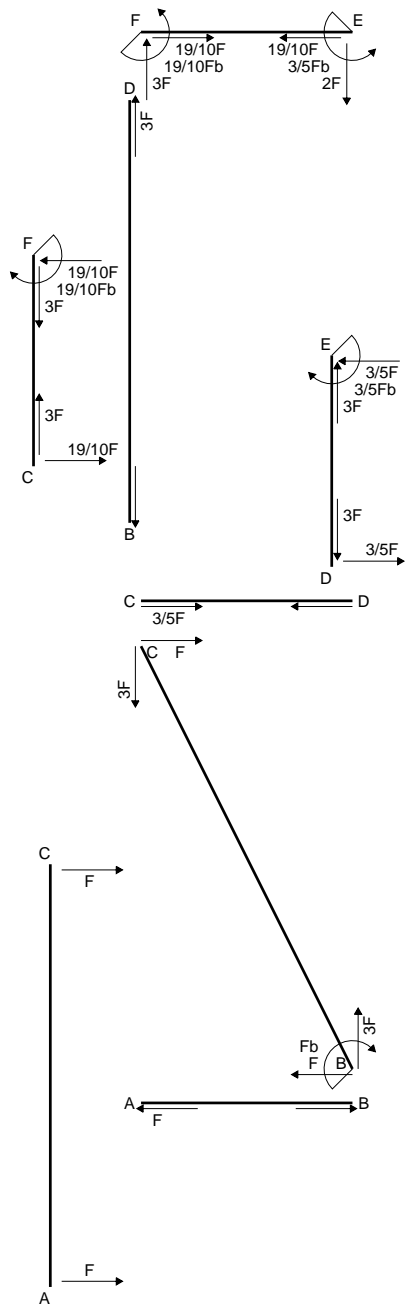

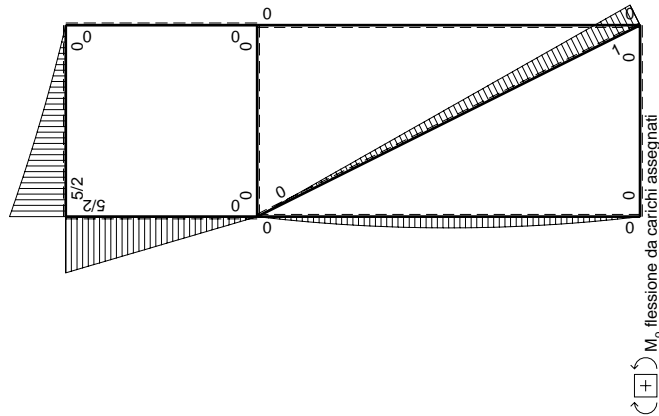
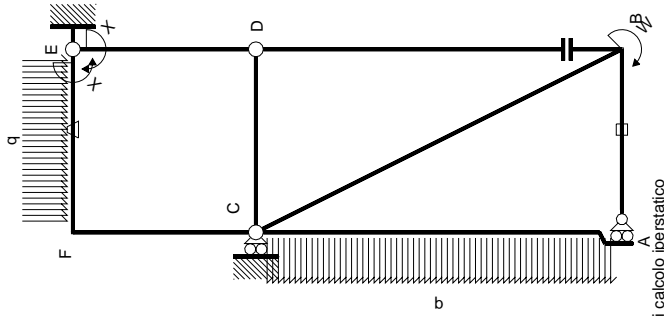

Quadro contribuiti PLV per iperstatica $X=W_{EF}$

\rightarrow	$M^x(x)$	$M^0(x)$	θ	$M^x M_0$	$M^x \theta$	$M^x M_x$	$\int M^x(M_0/EJ+\theta)dx$	$\int M^x M_x/EJdx$
AB b	0	0	0	0	0	0	0	0
BA b	0	0	0	0	0	0	0	0
BC $\sqrt{5}b$	0	$Fb-\sqrt{5}/5Fx$	0	0	0	0	0	0
AC 2b	0	$-Fx+1/2qx^2$	0	0	0	0	0	0
CA 2b	0	$Fx-1/2qx^2$	0	0	0	0	0	0
DB 2b	0	0	0	0	0	0	0	0
BD 2b	0	0	0	0	0	0	0	0
DE b	$-x/b$	0	0	0	0	0	0	0
ED b	$1-x/b$	0	0	0	0	0	0	0
CD b	0	0	0	0	0	0	0	0
DC b	0	0	0	0	0	0	0	0
EF b	-1	$2Fx+1/2qx^2$	$-Fb/EJ$	$-2Fx-1/2Fx^2/b$	Fb/EJ	1	1	Xb/EJ
FE b	1	$-5/2Fb+3Fx-1/2qx^2$	Fb/EJ	$-5/2Fb+3Fx-1/2Fx^2/b$	Fb/EJ	1	1	Xb/EJ
FC b	$-1+x/b$	$5/2Fb-5/2Fx$	0	$-5/2Fb+5Fx-5/2Fx^2/b$	0	0	0	$1/3Xb/EJ$
CF b	x/b	$-5/2Fx$	0	$-5/2Fx^2/b$	0	0	0	$1/3Xb/EJ$
totali								$5/3Xb/EJ$
								$-Fb^2/EJ$
								$3/5Fb$

Sviluppi di calcolo iperstatica

$$L_{DE}^{xx} = \int_0^b (x^2/b^2) 1/EJ dx = [1/3 x^3/b^2]_0^b 1/EJ$$

$$= (1/3 b) 1/EJ = 1/3 b/EJ$$

$$L_{ED}^{xx} = \int_0^b (1 - 2x/b + x^2/b^2) 1/EJ dx = [x - x^2/b + 1/3 x^3/b^2]_0^b 1/EJ$$

$$= (b - b + 1/3 b) 1/EJ = 1/3 b/EJ$$

$$L_{EF}^{xx} = \int_0^b (1) 1/EJ dx = [x]_0^b 1/EJ$$

$$= (b) 1/EJ = b/EJ$$

$$L_{FE}^{xx} = \int_0^b (1) 1/EJ dx = [x]_0^b 1/EJ$$

$$= (b) 1/EJ = b/EJ$$

$$L_{FC}^{xx} = \int_0^b (1 - 2x/b + x^2/b^2) 1/EJ dx = [x - x^2/b + 1/3 x^3/b^2]_0^b 1/EJ$$

$$= (b - b + 1/3 b) 1/EJ = 1/3 b/EJ$$

$$L_{CF}^{xx} = \int_0^b (x^2/b^2) 1/EJ dx = [1/3 x^3/b^2]_0^b 1/EJ$$

$$= (1/3 b) 1/EJ = 1/3 b/EJ$$

$$L_{EF}^{xo} = \int_0^b (-2x/b - 1/2 x^2/b^2) Fb 1/EJ dx + \int_0^b (1) \theta dx = [-x^2/b - 1/6 x^3/b^2]_0^b Fb 1/EJ + [x]_0^b \theta$$

$$= (-b - 1/6 b) Fb 1/EJ + (b) \theta = -1/6 Fb^2/EJ$$

$$L_{FE}^{xo} = \int_0^b (-5/2 + 3x/b - 1/2 x^2/b^2) Fb 1/EJ dx + \int_0^b (-1) \theta dx$$

$$= [-5/2 x + 3/2 x^2/b - 1/6 x^3/b^2]_0^b Fb 1/EJ + [-x]_0^b \theta$$

$$= (-5/2 b + 3/2 b - 1/6 b) Fb 1/EJ + (-b) \theta = -1/6 Fb^2/EJ$$

$$L_{FC}^{xo} = \int_0^b (-5/2 + 5x/b - 5/2 x^2/b^2) Fb 1/EJ dx = [-5/2 x + 5/2 x^2/b - 5/6 x^3/b^2]_0^b Fb 1/EJ$$

$$= (-5/2 b + 5/2 b - 5/6 b) Fb 1/EJ = -5/6 Fb^2/EJ$$

$$L_{CF}^{xo} = \int_0^b (-5/2 x^2/b^2) Fb 1/EJ dx = [-5/6 x^3/b^2]_0^b Fb 1/EJ$$

$$= (-5/6 b) Fb 1/EJ = -5/6 Fb^2/EJ$$

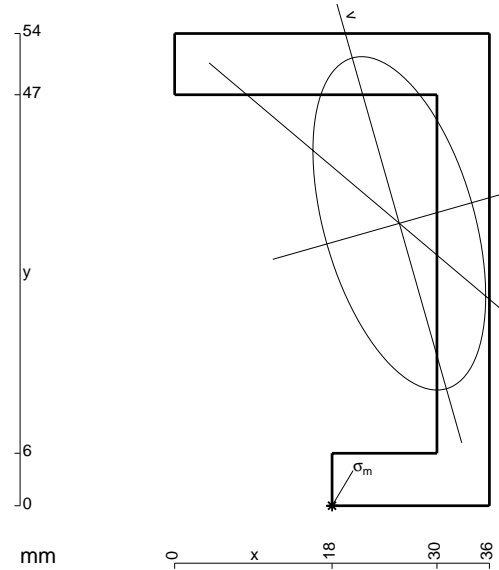

- A = 606. mm²
- J_x = 220278. mm⁴
- J_y = 59103. mm⁴
- J_{xy} = -49845. mm⁴
- J_u = 234447. mm⁴
- J_v = 44934. mm⁴
- α = arctg(2J_{xy}/(J_y-J_x))/2 = .2770
- c = cosα = .9619
- s = sinα = .2734
- x_g = 25.69 mm
- y_g = 32.29 mm
- N = -2109. N
- T_y = 3330. N
- M_x = 1117770. Nmm
- x_m = 18. mm
- u_m = -16.23 mm
- v_m = -28.96 mm
- σ_m = N/A - Mcv/J_v - Msu/J_u = 239.7 N/mm²

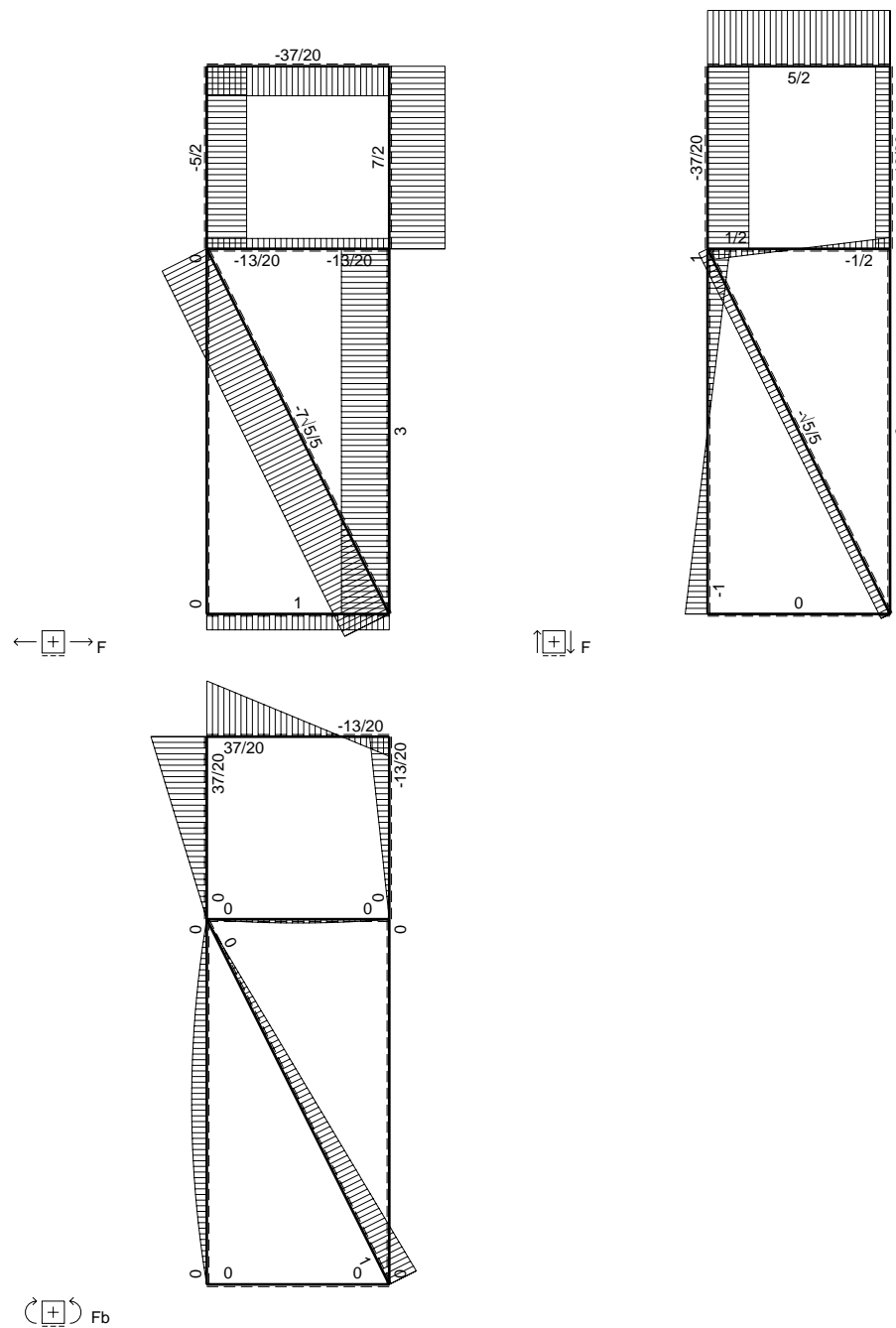
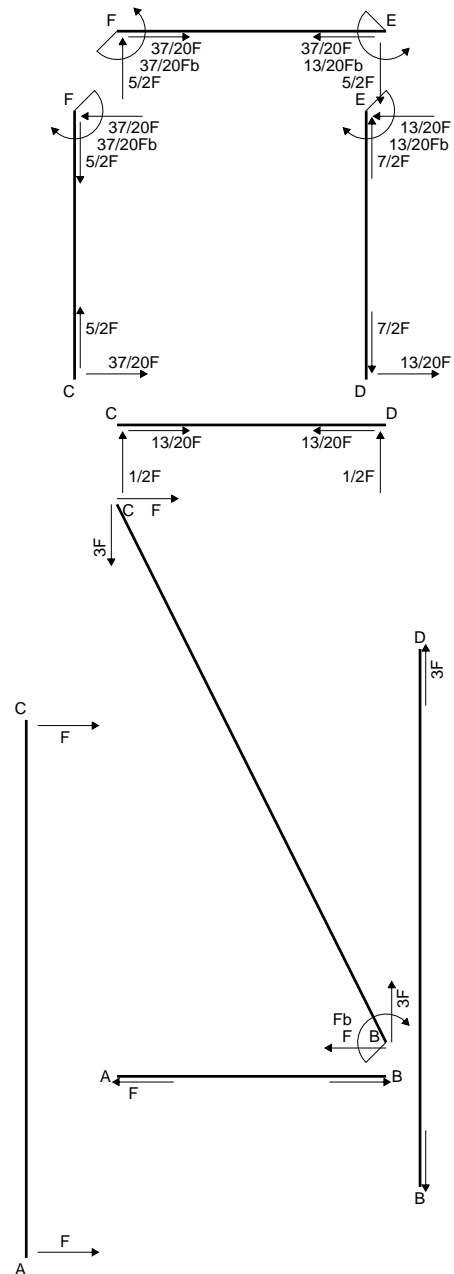

$$L_{DE}^{xx} = \int_0^b (x^2/b^2) 1/EJ dx = [1/3 x^3/b^2]_0^b 1/EJ$$

$$= (1/3 b) 1/EJ = 1/3 b/EJ$$

$$L_{ED}^{xx} = \int_0^b (1 - 2x/b + x^2/b^2) 1/EJ dx = [x - x^2/b + 1/3 x^3/b^2]_0^b 1/EJ$$

$$= (b - b + 1/3 b) 1/EJ = 1/3 b/EJ$$

$$L_{EF}^{xx} = \int_0^b (1) 1/EJ dx = [x]_0^b 1/EJ$$

$$= (b) 1/EJ = b/EJ$$

$$L_{FE}^{xx} = \int_0^b (1) 1/EJ dx = [x]_0^b 1/EJ$$

$$= (b) 1/EJ = b/EJ$$

$$L_{FC}^{xx} = \int_0^b (1 - 2x/b + x^2/b^2) 1/EJ dx = [x - x^2/b + 1/3 x^3/b^2]_0^b 1/EJ$$

$$= (b - b + 1/3 b) 1/EJ = 1/3 b/EJ$$

$$L_{CF}^{xx} = \int_0^b (x^2/b^2) 1/EJ dx = [1/3 x^3/b^2]_0^b 1/EJ$$

$$= (1/3 b) 1/EJ = 1/3 b/EJ$$

$$L_{EF}^{xo} = \int_0^b (-5/2 x/b) Fb 1/EJ dx + \int_0^b (1) \theta dx = [-5/4 x^2/b]_0^b Fb 1/EJ + [x]_0^b \theta$$

$$= (-5/4 b) Fb 1/EJ + (b) \theta = -1/4 Fb^2/EJ$$

$$L_{FE}^{xo} = \int_0^b (-5/2 + 5/2 x/b) Fb 1/EJ dx + \int_0^b (-1) \theta dx = [-5/2 x + 5/4 x^2/b]_0^b Fb 1/EJ + [-x]_0^b \theta$$

$$= (-5/2 b + 5/4 b) Fb 1/EJ + (-b) \theta = -1/4 Fb^2/EJ$$

$$L_{FC}^{xo} = \int_0^b (-5/2 + 5x/b - 5/2 x^2/b^2) Fb 1/EJ dx = [-5/2 x + 5/2 x^2/b - 5/6 x^3/b^2]_0^b Fb 1/EJ$$

$$= (-5/2 b + 5/2 b - 5/6 b) Fb 1/EJ = -5/6 Fb^2/EJ$$

$$L_{CF}^{xo} = \int_0^b (-5/2 x^2/b^2) Fb 1/EJ dx = [-5/6 x^3/b^2]_0^b Fb 1/EJ$$

$$= (-5/6 b) Fb 1/EJ = -5/6 Fb^2/EJ$$

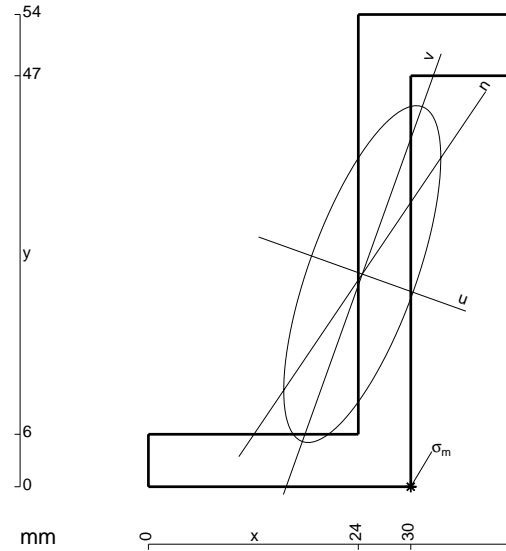

$$A = 552. \text{ mm}^2$$

$$J_x = 204861. \text{ mm}^4$$

$$J_y = 44525. \text{ mm}^4$$

$$J_{xy} = 65837. \text{ mm}^4$$

$$J_u = 228430. \text{ mm}^4$$

$$J_v = 20956. \text{ mm}^4$$

$$\alpha = \text{artg}(2J_{xy}/(J_y - J_x))/2 = -.3438$$

$$c = \cos \alpha = .9415$$

$$s = \sin \alpha = -.3370$$

$$x_g = 24.46 \text{ mm}$$

$$y_g = 24.32 \text{ mm}$$

$$N = -1166. \text{ N}$$

$$T_y = 1575. \text{ N}$$

$$M_x = 664335. \text{ Nmm}$$

$$x_m = 30. \text{ mm}$$

$$u_m = 13.41 \text{ mm}$$

$$v_m = -21.02 \text{ mm}$$

$$\sigma_m = N/A - Mcv/J_u - Msu/J_v = 198.8 \text{ N/mm}^2$$

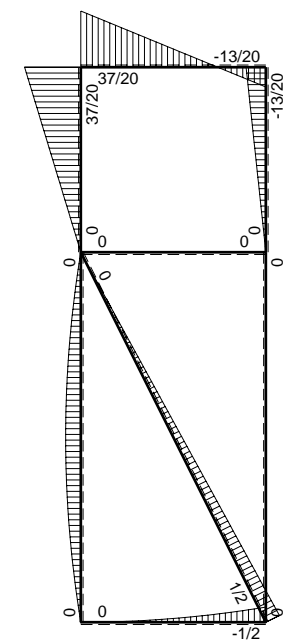
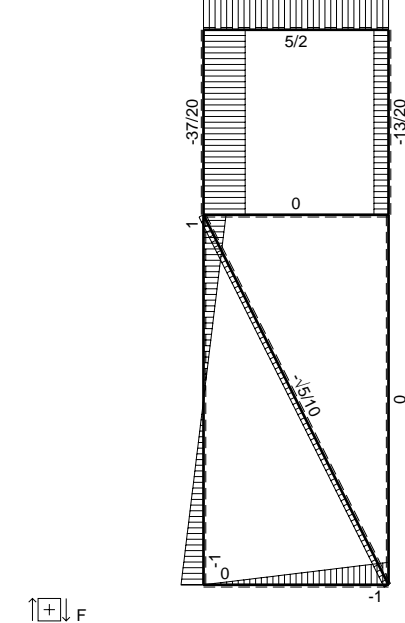
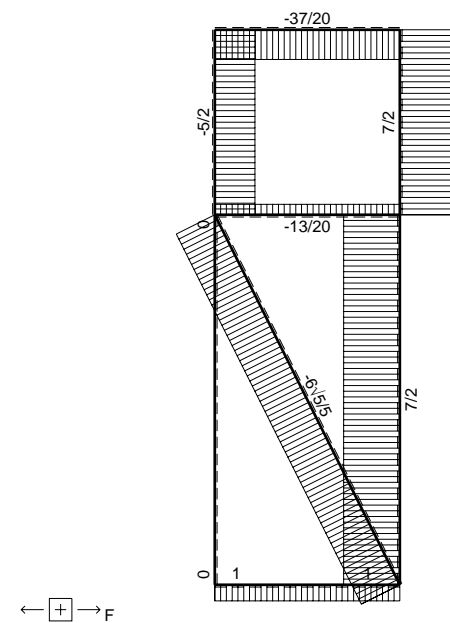
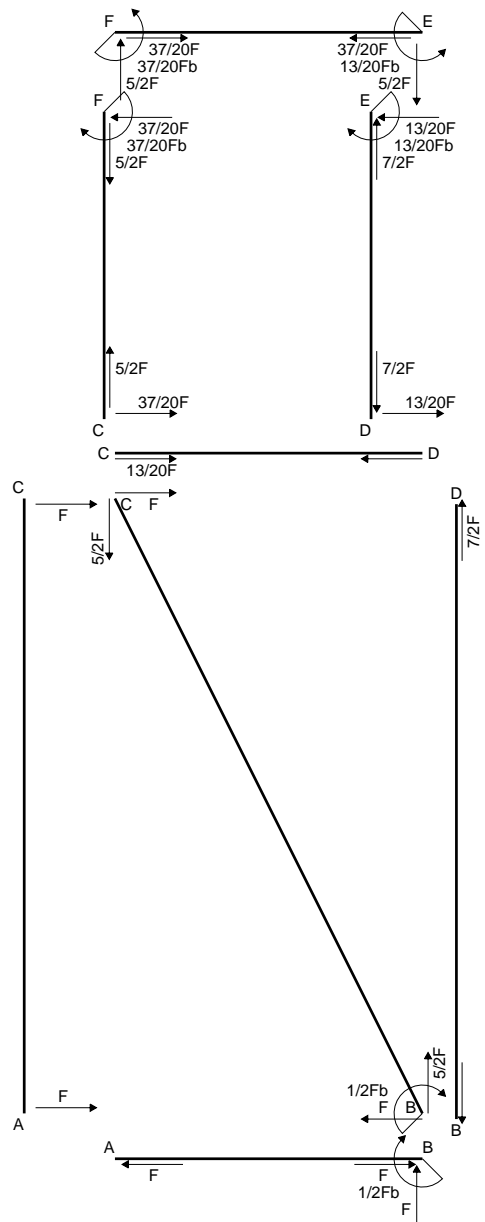

$$L_{DE}^{xx} = \int_0^b (x^2/b^2) 1/EJ dx = [1/3 x^3/b^2]_0^b 1/EJ$$

$$= (1/3 b) 1/EJ = 1/3 b/EJ$$

$$L_{ED}^{xx} = \int_0^b (1 - 2x/b + x^2/b^2) 1/EJ dx = [x - x^2/b + 1/3 x^3/b^2]_0^b 1/EJ$$

$$= (b - b + 1/3 b) 1/EJ = 1/3 b/EJ$$

$$L_{EF}^{xx} = \int_0^b (1) 1/EJ dx = [x]_0^b 1/EJ$$

$$= (b) 1/EJ = b/EJ$$

$$L_{FE}^{xx} = \int_0^b (1) 1/EJ dx = [x]_0^b 1/EJ$$

$$= (b) 1/EJ = b/EJ$$

$$L_{FC}^{xx} = \int_0^b (1 - 2x/b + x^2/b^2) 1/EJ dx = [x - x^2/b + 1/3 x^3/b^2]_0^b 1/EJ$$

$$= (b - b + 1/3 b) 1/EJ = 1/3 b/EJ$$

$$L_{CF}^{xx} = \int_0^b (x^2/b^2) 1/EJ dx = [1/3 x^3/b^2]_0^b 1/EJ$$

$$= (1/3 b) 1/EJ = 1/3 b/EJ$$

$$L_{EF}^{xo} = \int_0^b (-5/2 x/b) Fb 1/EJ dx + \int_0^b (1) \theta dx = [-5/4 x^2/b]_0^b Fb 1/EJ + [x]_0^b \theta$$

$$= (-5/4 b) Fb 1/EJ + (b) \theta = -1/4 Fb^2/EJ$$

$$L_{FE}^{xo} = \int_0^b (-5/2 + 5/2 x/b) Fb 1/EJ dx + \int_0^b (-1) \theta dx = [-5/2 x + 5/4 x^2/b]_0^b Fb 1/EJ + [-x]_0^b \theta$$

$$= (-5/2 b + 5/4 b) Fb 1/EJ + (-b) \theta = -1/4 Fb^2/EJ$$

$$L_{FC}^{xo} = \int_0^b (-5/2 + 5x/b - 5/2 x^2/b^2) Fb 1/EJ dx = [-5/2 x + 5/2 x^2/b - 5/6 x^3/b^2]_0^b Fb 1/EJ$$

$$= (-5/2 b + 5/2 b - 5/6 b) Fb 1/EJ = -5/6 Fb^2/EJ$$

$$L_{CF}^{xo} = \int_0^b (-5/2 x^2/b^2) Fb 1/EJ dx = [-5/6 x^3/b^2]_0^b Fb 1/EJ$$

$$= (-5/6 b) Fb 1/EJ = -5/6 Fb^2/EJ$$

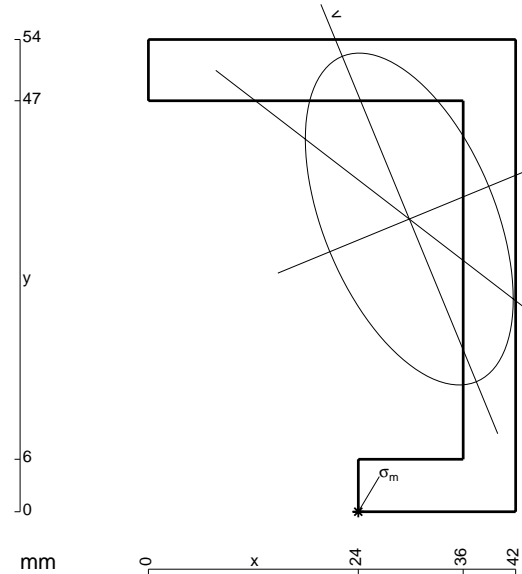

- A = 648. mm²
- J_x = 233472. mm⁴
- J_y = 91566. mm⁴
- J_{xy} = -70365. mm⁴
- J_u = 262446. mm⁴
- J_v = 62591. mm⁴
- α = artg(2J_{xy}/(J_y-J_x))/2 = .3906
- c = cosα = .9247
- s = sinα = .3808
- x_g = 29.83 mm
- y_g = 33.47 mm
- N = -1665. N
- T_y = 2250. N
- M_x = 999000. Nmm
- x_m = 24. mm
- u_m = -18.14 mm
- v_m = -28.73 mm
- σ_m = N/A - Mcv/J_u - Msu/J_v = 208.8 N/mm²

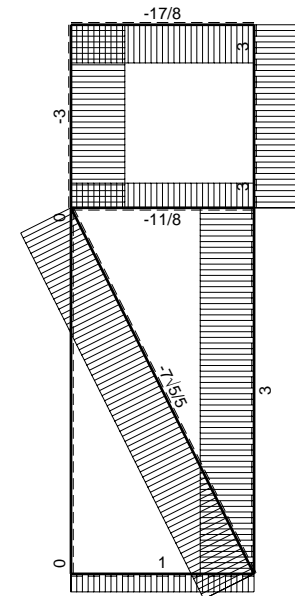
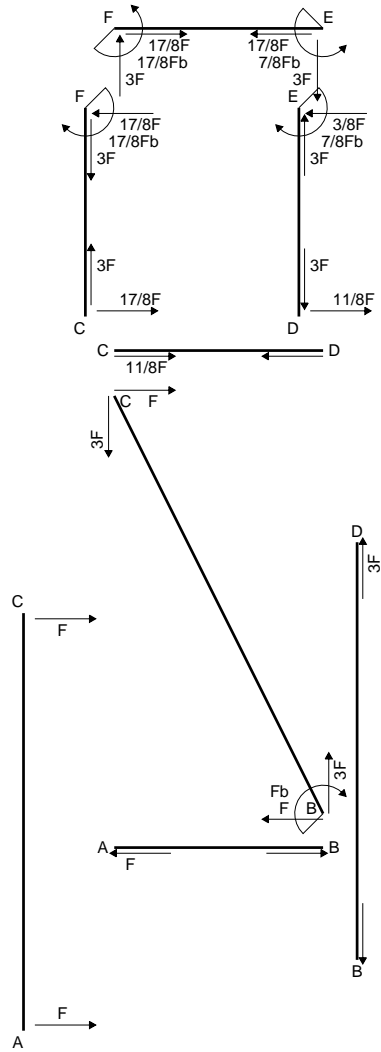

← ⊕ → F

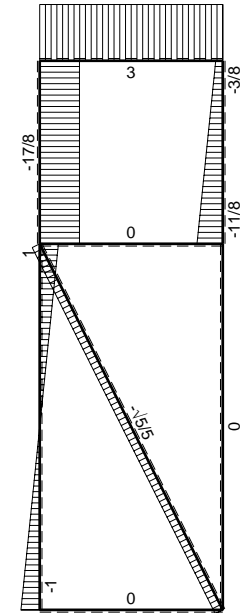

↑ ⊕ ↓ F

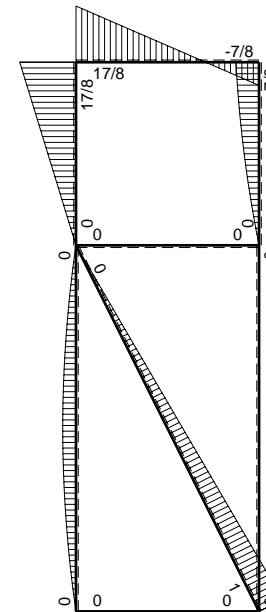

⊕ ⊖ F_b

$$L_{DE}^{xx} = \int_0^b (x^2/b^2) 1/EJ dx = [1/3 x^3/b^2]_0^b 1/EJ$$

$$= (1/3 b) 1/EJ = 1/3 b/EJ$$

$$L_{ED}^{xx} = \int_0^b (1 - 2x/b + x^2/b^2) 1/EJ dx = [x - x^2/b + 1/3 x^3/b^2]_0^b 1/EJ$$

$$= (b - b + 1/3 b) 1/EJ = 1/3 b/EJ$$

$$L_{EF}^{xx} = \int_0^b (1) 1/EJ dx = [x]_0^b 1/EJ$$

$$= (b) 1/EJ = b/EJ$$

$$L_{FE}^{xx} = \int_0^b (1) 1/EJ dx = [x]_0^b 1/EJ$$

$$= (b) 1/EJ = b/EJ$$

$$L_{FC}^{xx} = \int_0^b (1 - 2x/b + x^2/b^2) 1/EJ dx = [x - x^2/b + 1/3 x^3/b^2]_0^b 1/EJ$$

$$= (b - b + 1/3 b) 1/EJ = 1/3 b/EJ$$

$$L_{CF}^{xx} = \int_0^b (x^2/b^2) 1/EJ dx = [1/3 x^3/b^2]_0^b 1/EJ$$

$$= (1/3 b) 1/EJ = 1/3 b/EJ$$

$$L_{DE}^{xo} = \int_0^b (1/2 x^2/b^2 - 1/2 x^3/b^3) Fb 1/EJ dx = [1/6 x^3/b^2 - 1/8 x^4/b^3]_0^b Fb 1/EJ$$

$$= (1/6 b - 1/8 b) Fb 1/EJ = 1/24 Fb^2/EJ$$

$$L_{ED}^{xo} = \int_0^b (1/2 x/b - x^2/b^2 + 1/2 x^3/b^3) Fb 1/EJ dx = [1/4 x^2/b - 1/3 x^3/b^2 + 1/8 x^4/b^3]_0^b Fb 1/EJ$$

$$= (1/4 b - 1/3 b + 1/8 b) Fb 1/EJ = 1/24 Fb^2/EJ$$

$$L_{EF}^{xo} = \int_0^b (-3x/b) Fb 1/EJ dx + \int_0^b (1) \theta dx = [-3/2 x^2/b]_0^b Fb 1/EJ + [x]_0^b \theta$$

$$= (-3/2 b) Fb 1/EJ + (b) \theta = -1/2 Fb^2/EJ$$

$$L_{FE}^{xo} = \int_0^b (-3 + 3x/b) Fb 1/EJ dx + \int_0^b (-1) \theta dx = [-3x + 3/2 x^2/b]_0^b Fb 1/EJ + [-x]_0^b \theta$$

$$= (-3b + 3/2 b) Fb 1/EJ + (-b) \theta = -1/2 Fb^2/EJ$$

$$L_{FC}^{xo} = \int_0^b (-3 + 6x/b - 3x^2/b^2) Fb 1/EJ dx = [-3x + 3x^2/b - x^3/b^2]_0^b Fb 1/EJ$$

$$= (-3b + 3b - b) Fb 1/EJ = - Fb^2/EJ$$

$$L_{CF}^{xo} = \int_0^b (-3x^2/b^2) Fb 1/EJ dx = [-x^3/b^2]_0^b Fb 1/EJ$$

$$= (-b) Fb 1/EJ = - Fb^2/EJ$$

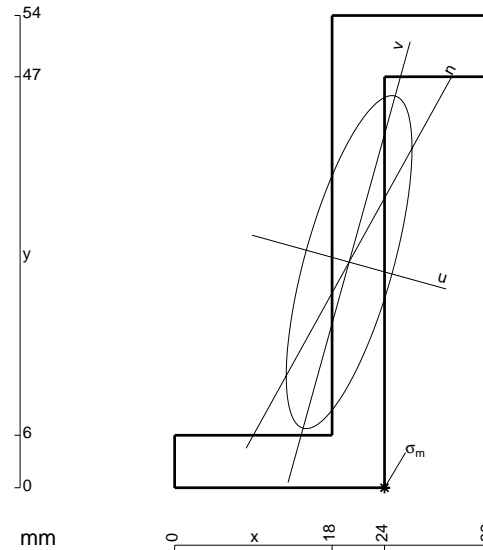

$$A = 516. \text{ mm}^2$$

$$J_x = 187256. \text{ mm}^4$$

$$J_y = 26687. \text{ mm}^4$$

$$J_{xy} = 48223. \text{ mm}^4$$

$$J_u = 200625. \text{ mm}^4$$

$$J_v = 13317. \text{ mm}^4$$

$$\alpha = \text{artg}(2J_{xy}/(J_y - J_x))/2 = -.2704$$

$$c = \cos \alpha = .9637$$

$$s = \sin \alpha = -.2672$$

$$x_g = 19.95 \text{ mm}$$

$$y_g = 25.8 \text{ mm}$$

$$N = -1041. \text{ N}$$

$$T_y = 1470. \text{ N}$$

$$M_x = 666400. \text{ Nmm}$$

$$x_m = 24. \text{ mm}$$

$$u_m = 10.79 \text{ mm}$$

$$v_m = -23.78 \text{ mm}$$

$$\sigma_m = N/A - Mcv/J_u - Msu/J_v = 218.4 \text{ N/mm}^2$$

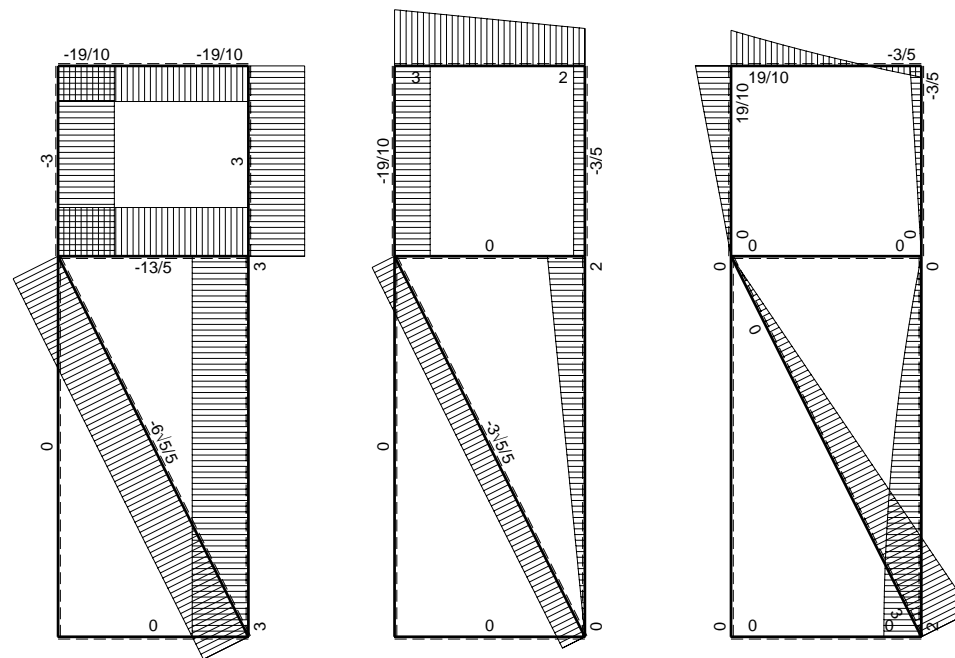
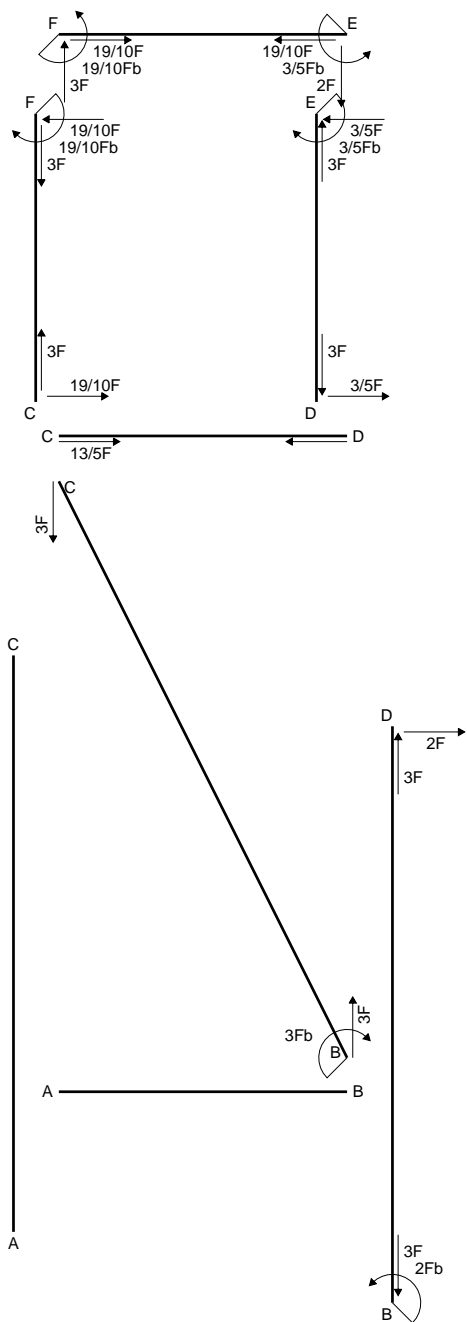

$$L_{DE}^{xx} = \int_0^b (x^2/b^2) 1/EJ dx = [1/3 x^3/b^2]_0^b 1/EJ$$

$$= (1/3 b) 1/EJ = 1/3 b/EJ$$

$$L_{ED}^{xx} = \int_0^b (1 - 2x/b + x^2/b^2) 1/EJ dx = [x - x^2/b + 1/3 x^3/b^2]_0^b 1/EJ$$

$$= (b - b + 1/3 b) 1/EJ = 1/3 b/EJ$$

$$L_{EF}^{xx} = \int_0^b (1) 1/EJ dx = [x]_0^b 1/EJ$$

$$= (b) 1/EJ = b/EJ$$

$$L_{FE}^{xx} = \int_0^b (1) 1/EJ dx = [x]_0^b 1/EJ$$

$$= (b) 1/EJ = b/EJ$$

$$L_{FC}^{xx} = \int_0^b (1 - 2x/b + x^2/b^2) 1/EJ dx = [x - x^2/b + 1/3 x^3/b^2]_0^b 1/EJ$$

$$= (b - b + 1/3 b) 1/EJ = 1/3 b/EJ$$

$$L_{CF}^{xx} = \int_0^b (x^2/b^2) 1/EJ dx = [1/3 x^3/b^2]_0^b 1/EJ$$

$$= (1/3 b) 1/EJ = 1/3 b/EJ$$

$$L_{EF}^{xo} = \int_0^b (-2x/b - 1/2 x^2/b^2) Fb 1/EJ dx + \int_0^b (1) \theta dx = [-x^2/b - 1/6 x^3/b^2]_0^b Fb 1/EJ + [x]_0^b \theta$$

$$= (-b - 1/6 b) Fb 1/EJ + (b) \theta = -1/6 Fb^2/EJ$$

$$L_{FE}^{xo} = \int_0^b (-5/2 + 3x/b - 1/2 x^2/b^2) Fb 1/EJ dx + \int_0^b (-1) \theta dx$$

$$= [-5/2 x + 3/2 x^2/b - 1/6 x^3/b^2]_0^b Fb 1/EJ + [-x]_0^b \theta$$

$$= (-5/2 b + 3/2 b - 1/6 b) Fb 1/EJ + (-b) \theta = -1/6 Fb^2/EJ$$

$$L_{FC}^{xo} = \int_0^b (-5/2 + 5x/b - 5/2 x^2/b^2) Fb 1/EJ dx = [-5/2 x + 5/2 x^2/b - 5/6 x^3/b^2]_0^b Fb 1/EJ$$

$$= (-5/2 b + 5/2 b - 5/6 b) Fb 1/EJ = -5/6 Fb^2/EJ$$

$$L_{CF}^{xo} = \int_0^b (-5/2 x^2/b^2) Fb 1/EJ dx = [-5/6 x^3/b^2]_0^b Fb 1/EJ$$

$$= (-5/6 b) Fb 1/EJ = -5/6 Fb^2/EJ$$

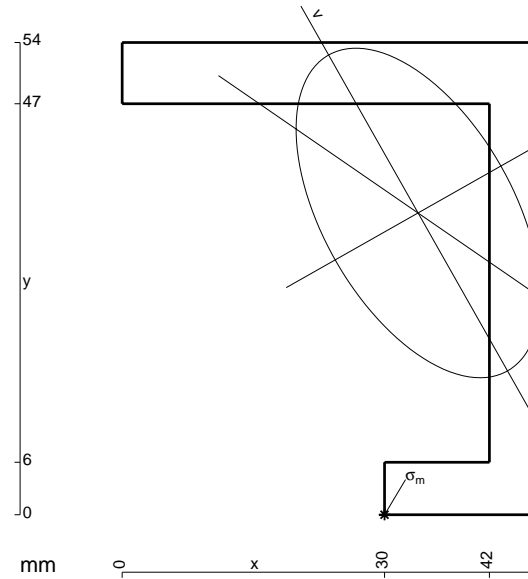

- A = 690. mm²
- J_x = 245079. mm⁴
- J_y = 134213. mm⁴
- J_{xy} = -92417. mm⁴
- J_u = 297413. mm⁴
- J_v = 81879. mm⁴
- α = arctg(2J_{xy}/(J_y-J_x))/2 = .5153
- c = cos α = .8702
- s = sin α = .4928
- x_g = 33.83 mm
- y_g = 34.51 mm
- N = -1476. N
- T_y = -737.9 N
- M_x = 1122000. Nmm
- x_m = 30. mm
- u_m = -20.34 mm
- v_m = -28.14 mm
- σ_m = N/A - Mcv/J_u - Msu/J_v = 227.6 N/mm²

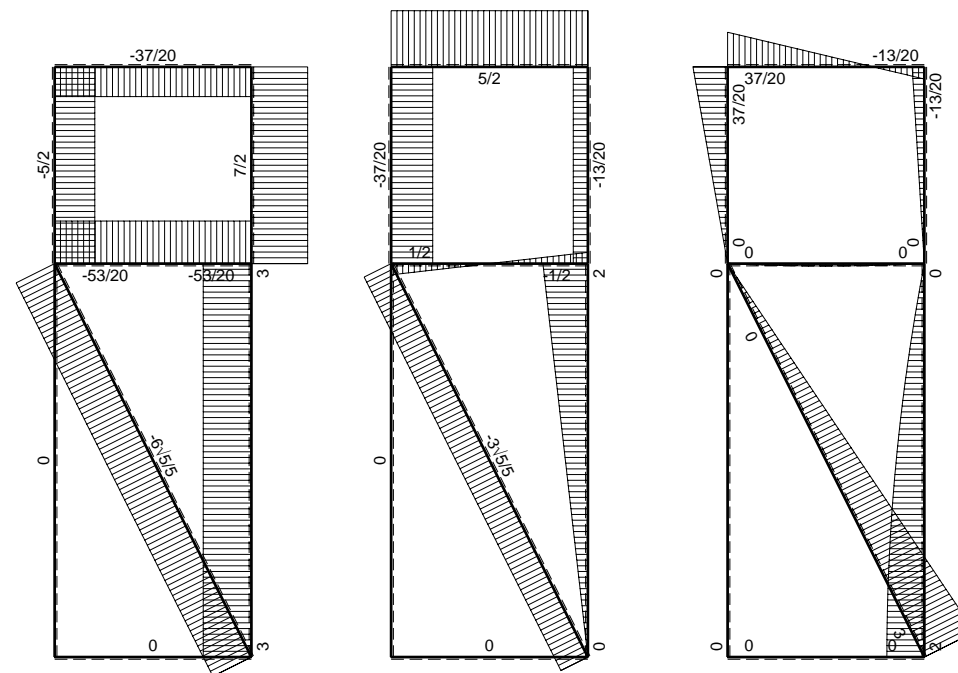
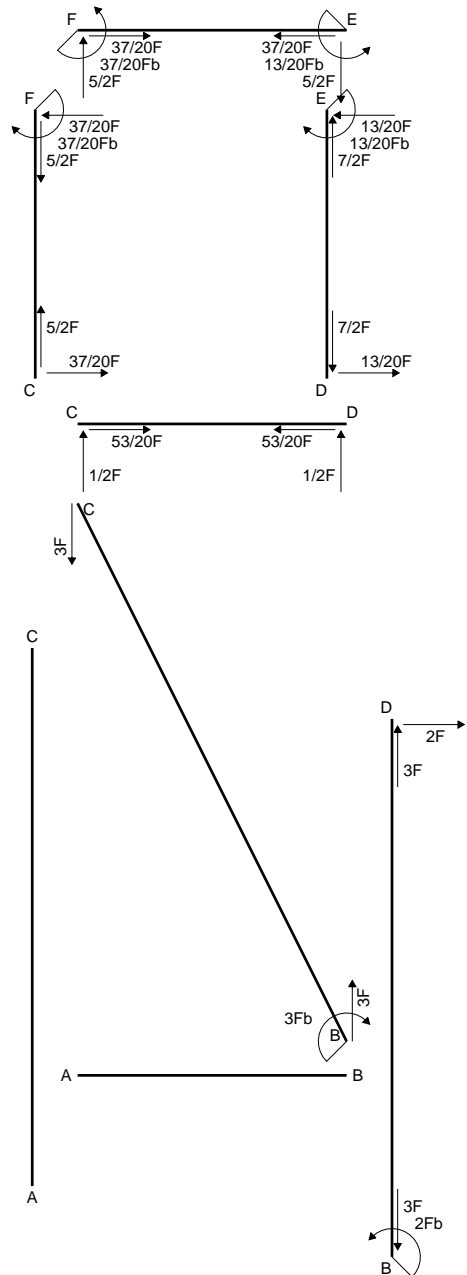

← ⊕ → F

↑ ⊕ ↓ F

⊕ ⊖ F_b

$$L_{DE}^{xx} = \int_0^b (x^2/b^2) 1/EJ dx = [1/3 x^3/b^2]_0^b 1/EJ$$

$$= (1/3 b) 1/EJ = 1/3 b/EJ$$

$$L_{ED}^{xx} = \int_0^b (1 - 2x/b + x^2/b^2) 1/EJ dx = [x - x^2/b + 1/3 x^3/b^2]_0^b 1/EJ$$

$$= (b - b + 1/3 b) 1/EJ = 1/3 b/EJ$$

$$L_{EF}^{xx} = \int_0^b (1) 1/EJ dx = [x]_0^b 1/EJ$$

$$= (b) 1/EJ = b/EJ$$

$$L_{FE}^{xx} = \int_0^b (1) 1/EJ dx = [x]_0^b 1/EJ$$

$$= (b) 1/EJ = b/EJ$$

$$L_{FC}^{xx} = \int_0^b (1 - 2x/b + x^2/b^2) 1/EJ dx = [x - x^2/b + 1/3 x^3/b^2]_0^b 1/EJ$$

$$= (b - b + 1/3 b) 1/EJ = 1/3 b/EJ$$

$$L_{CF}^{xx} = \int_0^b (x^2/b^2) 1/EJ dx = [1/3 x^3/b^2]_0^b 1/EJ$$

$$= (1/3 b) 1/EJ = 1/3 b/EJ$$

$$L_{EF}^{xo} = \int_0^b (-5/2 x/b) Fb 1/EJ dx + \int_0^b (1) \theta dx = [-5/4 x^2/b]_0^b Fb 1/EJ + [x]_0^b \theta$$

$$= (-5/4 b) Fb 1/EJ + (b) \theta = -1/4 Fb^2/EJ$$

$$L_{FE}^{xo} = \int_0^b (-5/2 + 5/2 x/b) Fb 1/EJ dx + \int_0^b (-1) \theta dx = [-5/2 x + 5/4 x^2/b]_0^b Fb 1/EJ + [-x]_0^b \theta$$

$$= (-5/2 b + 5/4 b) Fb 1/EJ + (-b) \theta = -1/4 Fb^2/EJ$$

$$L_{FC}^{xo} = \int_0^b (-5/2 + 5x/b - 5/2 x^2/b^2) Fb 1/EJ dx = [-5/2 x + 5/2 x^2/b - 5/6 x^3/b^2]_0^b Fb 1/EJ$$

$$= (-5/2 b + 5/2 b - 5/6 b) Fb 1/EJ = -5/6 Fb^2/EJ$$

$$L_{CF}^{xo} = \int_0^b (-5/2 x^2/b^2) Fb 1/EJ dx = [-5/6 x^3/b^2]_0^b Fb 1/EJ$$

$$= (-5/6 b) Fb 1/EJ = -5/6 Fb^2/EJ$$

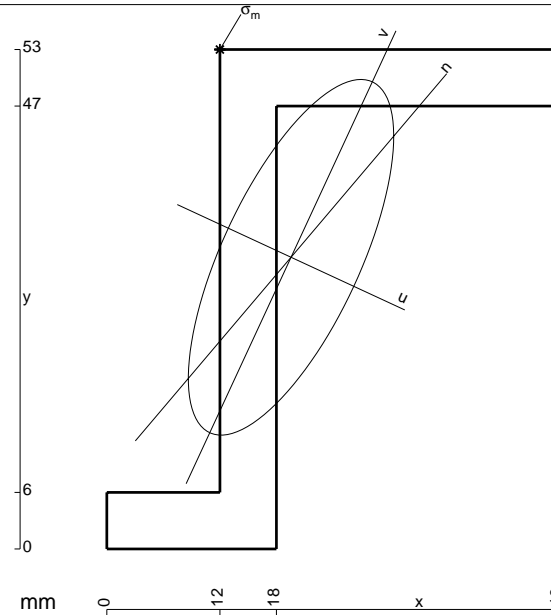

- A = 570. mm²
- J_x = 203061. mm⁴
- J_y = 67683. mm⁴
- J_{xy} = 79827. mm⁴
- J_u = 240034. mm⁴
- J_v = 30710. mm⁴
- α = arctg(2J_{xy}/(J_y-J_x))/2 = -.4337
- c = cos α = .9074
- s = sin α = -.4203
- x_g = 19.55 mm
- y_g = 30.95 mm
- N = -1046. N
- T_y = -523.2 N
- M_x = 819000. Nmm
- x_m = 12. mm
- y_m = 53. mm
- u_m = -16.11 mm
- v_m = 16.83 mm
- σ_m = N/A - Mcv/J_u - Msu/J_v = -234.6 N/mm²

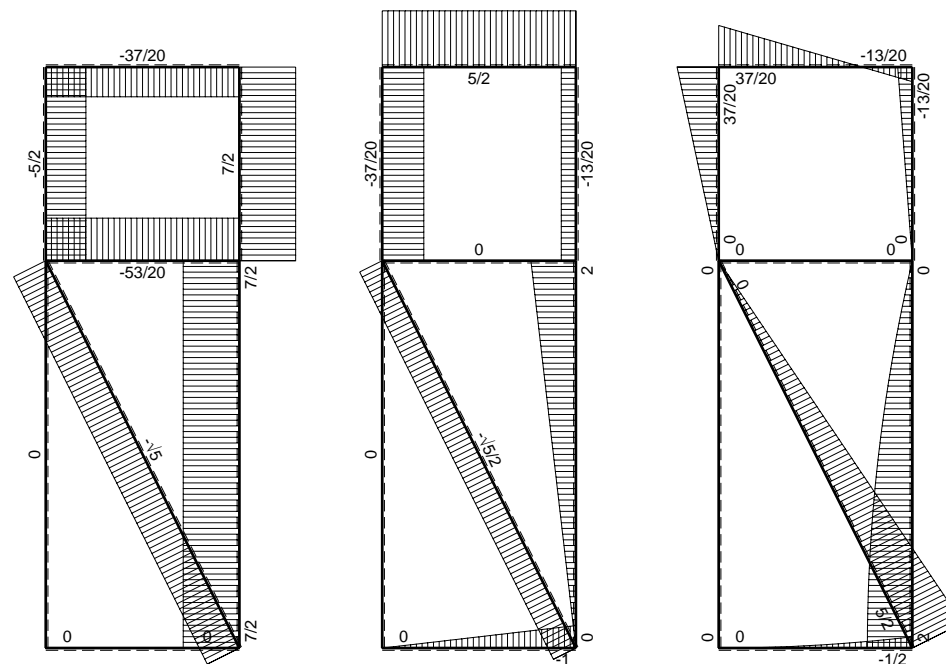
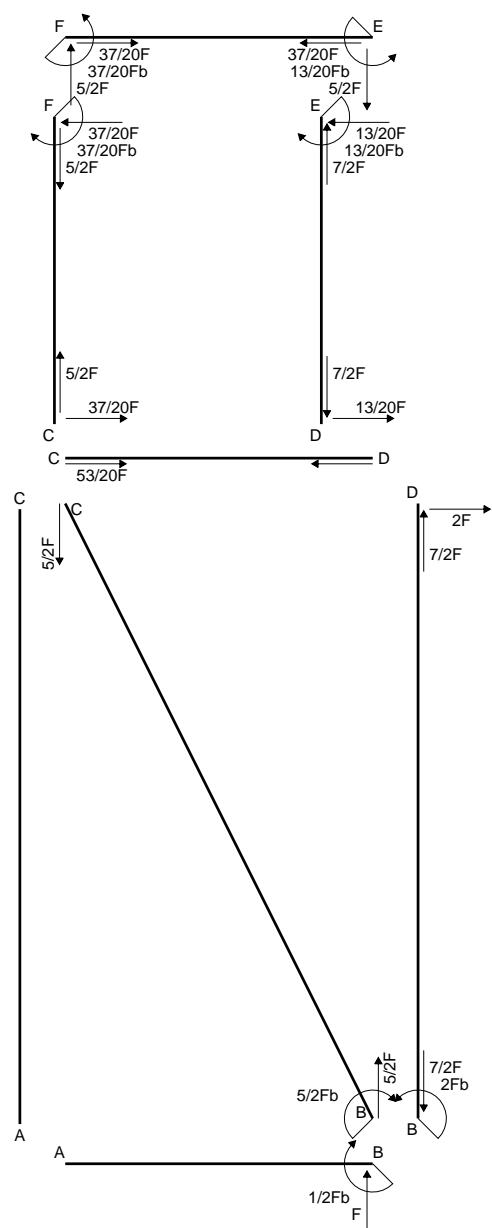

$$L_{DE}^{xx} = \int_0^b (x^2/b^2) 1/EJ dx = [1/3 x^3/b^2]_0^b 1/EJ$$

$$= (1/3 b) 1/EJ = 1/3 b/EJ$$

$$L_{ED}^{xx} = \int_0^b (1 - 2x/b + x^2/b^2) 1/EJ dx = [x - x^2/b + 1/3 x^3/b^2]_0^b 1/EJ$$

$$= (b - b + 1/3 b) 1/EJ = 1/3 b/EJ$$

$$L_{EF}^{xx} = \int_0^b (1) 1/EJ dx = [x]_0^b 1/EJ$$

$$= (b) 1/EJ = b/EJ$$

$$L_{FE}^{xx} = \int_0^b (1) 1/EJ dx = [x]_0^b 1/EJ$$

$$= (b) 1/EJ = b/EJ$$

$$L_{FC}^{xx} = \int_0^b (1 - 2x/b + x^2/b^2) 1/EJ dx = [x - x^2/b + 1/3 x^3/b^2]_0^b 1/EJ$$

$$= (b - b + 1/3 b) 1/EJ = 1/3 b/EJ$$

$$L_{CF}^{xx} = \int_0^b (x^2/b^2) 1/EJ dx = [1/3 x^3/b^2]_0^b 1/EJ$$

$$= (1/3 b) 1/EJ = 1/3 b/EJ$$

$$L_{EF}^{xo} = \int_0^b (-5/2 x/b) Fb 1/EJ dx + \int_0^b (1) \theta dx = [-5/4 x^2/b]_0^b Fb 1/EJ + [x]_0^b \theta$$

$$= (-5/4 b) Fb 1/EJ + (b) \theta = -1/4 Fb^2/EJ$$

$$L_{FE}^{xo} = \int_0^b (-5/2 + 5/2 x/b) Fb 1/EJ dx + \int_0^b (-1) \theta dx = [-5/2 x + 5/4 x^2/b]_0^b Fb 1/EJ + [-x]_0^b \theta$$

$$= (-5/2 b + 5/4 b) Fb 1/EJ + (-b) \theta = -1/4 Fb^2/EJ$$

$$L_{FC}^{xo} = \int_0^b (-5/2 + 5x/b - 5/2 x^2/b^2) Fb 1/EJ dx = [-5/2 x + 5/2 x^2/b - 5/6 x^3/b^2]_0^b Fb 1/EJ$$

$$= (-5/2 b + 5/2 b - 5/6 b) Fb 1/EJ = -5/6 Fb^2/EJ$$

$$L_{CF}^{xo} = \int_0^b (-5/2 x^2/b^2) Fb 1/EJ dx = [-5/6 x^3/b^2]_0^b Fb 1/EJ$$

$$= (-5/6 b) Fb 1/EJ = -5/6 Fb^2/EJ$$

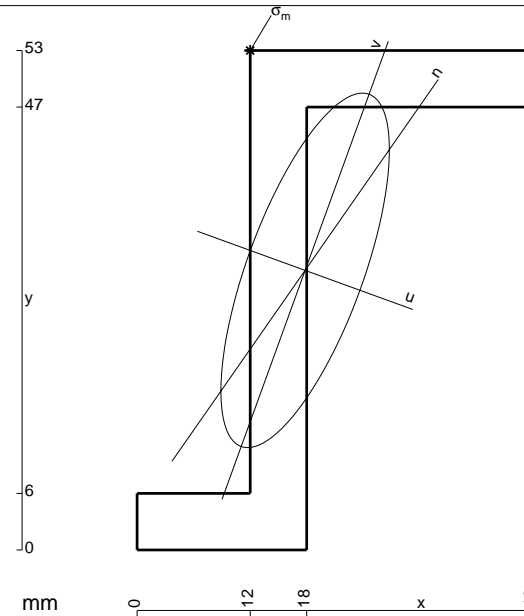

$$A = 534. \text{ mm}^2$$

$$J_x = 189011. \text{ mm}^4$$

$$J_y = 42681. \text{ mm}^4$$

$$J_{xy} = 61197. \text{ mm}^4$$

$$J_u = 211231. \text{ mm}^4$$

$$J_v = 20461. \text{ mm}^4$$

$$\alpha = \text{artg}(2J_{xy}/(J_y - J_x))/2 = -.3483$$

$$c = \cos \alpha = .9400$$

$$s = \sin \alpha = -.3413$$

$$x_g = 17.83 \text{ mm}$$

$$y_g = 29.67 \text{ mm}$$

$$N = -1521. \text{ N}$$

$$T_y = -760.3 \text{ N}$$

$$M_x = 629000. \text{ Nmm}$$

$$x_m = 12. \text{ mm}$$

$$y_m = 53. \text{ mm}$$

$$u_m = -13.44 \text{ mm}$$

$$v_m = 19.94 \text{ mm}$$

$$\sigma_m = N/A - Mcv/J_u - Msu/J_v = -199.7 \text{ N/mm}^2$$

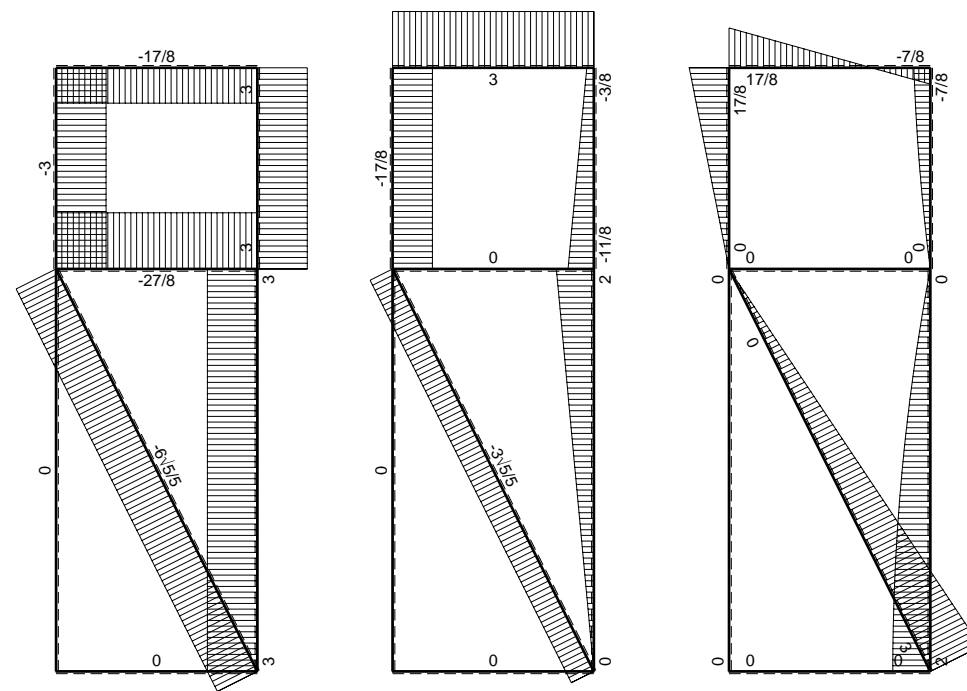
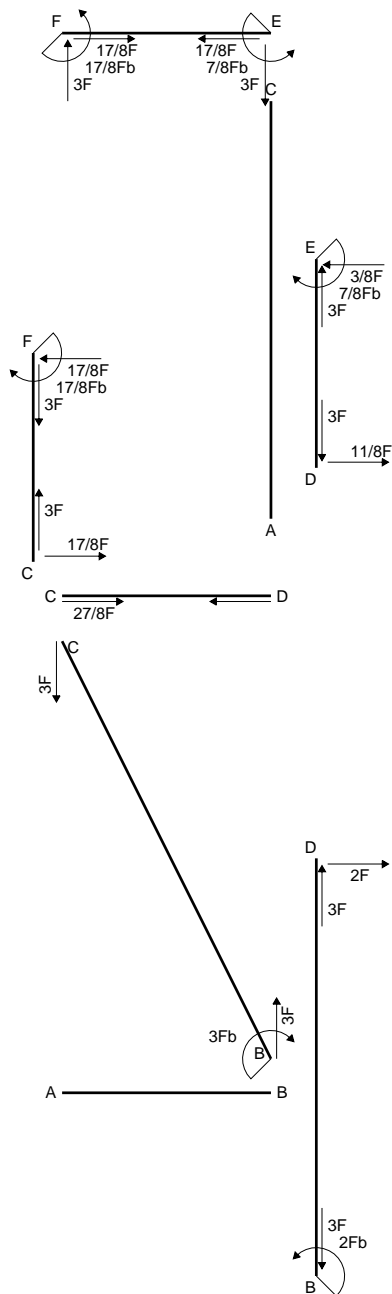

← ⊕ → F

↑ ⊕ ↓ F

⊕ ⊖ F_b

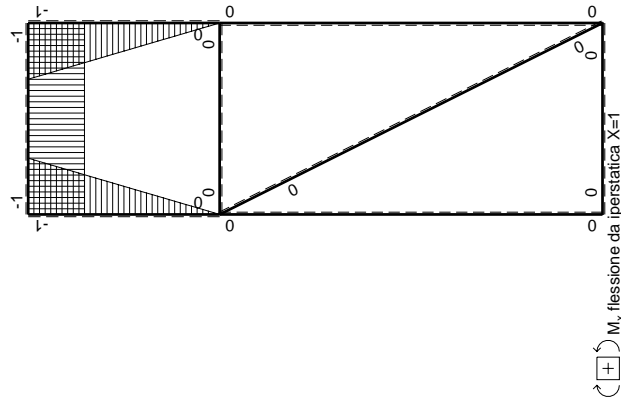
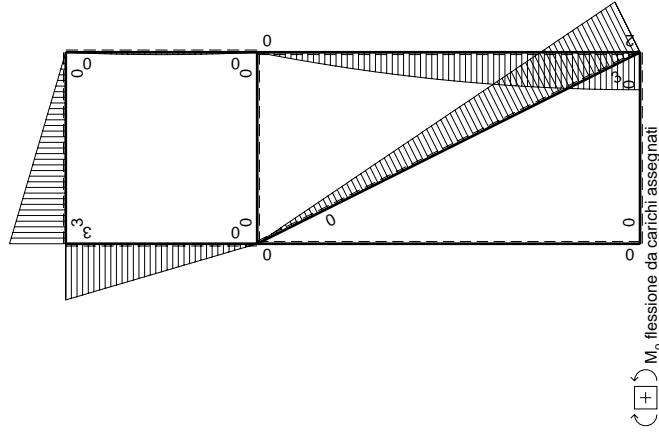
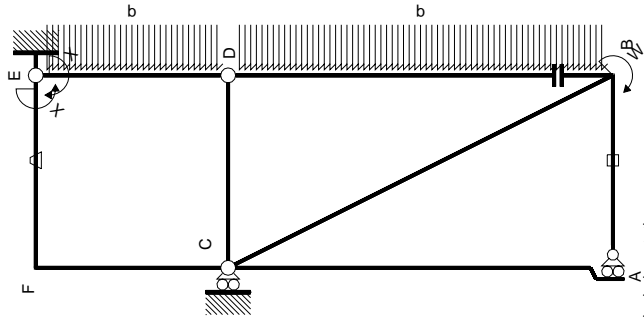

Quadro contributi PLV per iperstatica $X=W_{EF}$

\leftarrow	$M^x(x)$	$M^0(x)$	θ	$M^x M_0$	$M^x \theta$	$M^x M_x$	$\int M^x (M_0/EJ + \theta) dx$	$\int M^x M_x / EJ dx$
AB b	0	0	0	0	0	0	0+0	0
BA b	0	0	0	0	0	0	0	0
BC $\sqrt{5}b$	0	$3Fb-3\sqrt{5}/5Fx$	0	0	0	0	0+0	0
CA 2b	0	0	0	0	0	0	0+0	0
DB 2b	0	$2Fx-1/2qx^2$	0	0	0	0	0+0	0
BD 2b	0	$-2Fb+1/2qx^2$	0	0	0	0	0+0	0
DE b	$-x/b$	$-1/2Fx+1/2qx^2$	0	$1/2Fx^2/b-1/2qx^3/b$	0	0	x^2/b^2	$1/3Xb/EJ$
ED b	$1-x/b$	$1/2Fx-1/2qx^2$	0	$1/2Fx-Fx^2/b+1/2qx^3/b$	0	0	$1-2x/b+x^2/b^2$	$1/3Xb/EJ$
CD b	0	0	0	0	0	0	0+0	0
DC b	0	0	0	0	0	0	0+0	0
EF b	-1	$3Fx$	$-Fb/EJ$	$-3Fx$	Fb/EJ	1	$(-3/2+1)Fb^2/EJ$	Xb/EJ
FE b	1	$-3Fb+3Fx$	Fb/EJ	$-3Fb+3Fx$	Fb/EJ	1	$(-3/2+1)Fb^2/EJ$	Xb/EJ
FC b	$-1+x/b$	$3Fb-3Fx$	0	$-3Fb+6Fx-3Fx^2/b$	0	0	$1-2x/b+x^2/b^2$	$1/3Xb/EJ$
CF b	x/b	$-3Fx$	0	$-3Fx^2/b$	0	0	x^2/b^2	$1/3Xb/EJ$
totali							$-35/24Fb^2/EJ$	$5/3Xb/EJ$
							$7/8Fb$	

Sviluppi di calcolo iperstatica

$$L_{DE}^{xx} = \int_0^b (x^2/b^2) 1/EJ dx = [1/3 x^3/b^2]_0^b 1/EJ$$

$$= (1/3 b) 1/EJ = 1/3 b/EJ$$

$$L_{ED}^{xx} = \int_0^b (1 - 2x/b + x^2/b^2) 1/EJ dx = [x - x^2/b + 1/3 x^3/b^2]_0^b 1/EJ$$

$$= (b - b + 1/3 b) 1/EJ = 1/3 b/EJ$$

$$L_{EF}^{xx} = \int_0^b (1) 1/EJ dx = [x]_0^b 1/EJ$$

$$= (b) 1/EJ = b/EJ$$

$$L_{FE}^{xx} = \int_0^b (1) 1/EJ dx = [x]_0^b 1/EJ$$

$$= (b) 1/EJ = b/EJ$$

$$L_{FC}^{xx} = \int_0^b (1 - 2x/b + x^2/b^2) 1/EJ dx = [x - x^2/b + 1/3 x^3/b^2]_0^b 1/EJ$$

$$= (b - b + 1/3 b) 1/EJ = 1/3 b/EJ$$

$$L_{CF}^{xx} = \int_0^b (x^2/b^2) 1/EJ dx = [1/3 x^3/b^2]_0^b 1/EJ$$

$$= (1/3 b) 1/EJ = 1/3 b/EJ$$

$$L_{DE}^{xo} = \int_0^b (1/2 x^2/b^2 - 1/2 x^3/b^3) Fb 1/EJ dx = [1/6 x^3/b^2 - 1/8 x^4/b^3]_0^b Fb 1/EJ$$

$$= (1/6 b - 1/8 b) Fb 1/EJ = 1/24 Fb^2/EJ$$

$$L_{ED}^{xo} = \int_0^b (1/2 x/b - x^2/b^2 + 1/2 x^3/b^3) Fb 1/EJ dx = [1/4 x^2/b - 1/3 x^3/b^2 + 1/8 x^4/b^3]_0^b Fb 1/EJ$$

$$= (1/4 b - 1/3 b + 1/8 b) Fb 1/EJ = 1/24 Fb^2/EJ$$

$$L_{EF}^{xo} = \int_0^b (-3x/b) Fb 1/EJ dx + \int_0^b (1) \theta dx = [-3/2 x^2/b]_0^b Fb 1/EJ + [x]_0^b \theta$$

$$= (-3/2 b) Fb 1/EJ + (b) \theta = -1/2 Fb^2/EJ$$

$$L_{FE}^{xo} = \int_0^b (-3 + 3x/b) Fb 1/EJ dx + \int_0^b (-1) \theta dx = [-3x + 3/2 x^2/b]_0^b Fb 1/EJ + [-x]_0^b \theta$$

$$= (-3b + 3/2 b) Fb 1/EJ + (-b) \theta = -1/2 Fb^2/EJ$$

$$L_{FC}^{xo} = \int_0^b (-3 + 6x/b - 3x^2/b^2) Fb 1/EJ dx = [-3x + 3x^2/b - x^3/b^2]_0^b Fb 1/EJ$$

$$= (-3b + 3b - b) Fb 1/EJ = - Fb^2/EJ$$

$$L_{CF}^{xo} = \int_0^b (-3x^2/b^2) Fb 1/EJ dx = [-x^3/b^2]_0^b Fb 1/EJ$$

$$= (-b) Fb 1/EJ = - Fb^2/EJ$$

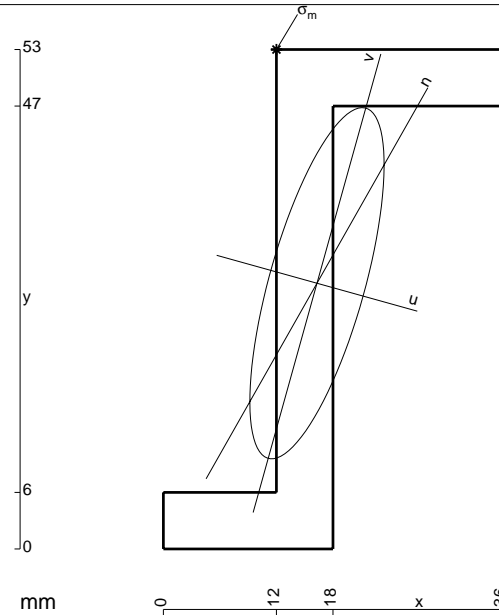

- A = 498. mm²
- J_x = 172946. mm⁴
- J_y = 25275. mm⁴
- J_{xy} = 44583. mm⁴
- J_u = 185362. mm⁴
- J_v = 12859. mm⁴
- α = arctg(2J_{xy}/(J_y-J_x))/2 = -.2716
- c = cos α = .9633
- s = sin α = -.2683
- x_g = 16.3 mm
- y_g = 28.2 mm
- N = -1342. N
- T_y = -670.8 N
- M_x = 600000. Nmm
- x_m = 12. mm
- y_m = 53. mm
- u_m = -10.8 mm
- v_m = 22.74 mm
- σ_m = N/A - Mc_v/J_u - Ms_u/J_v = -208.8 N/mm²

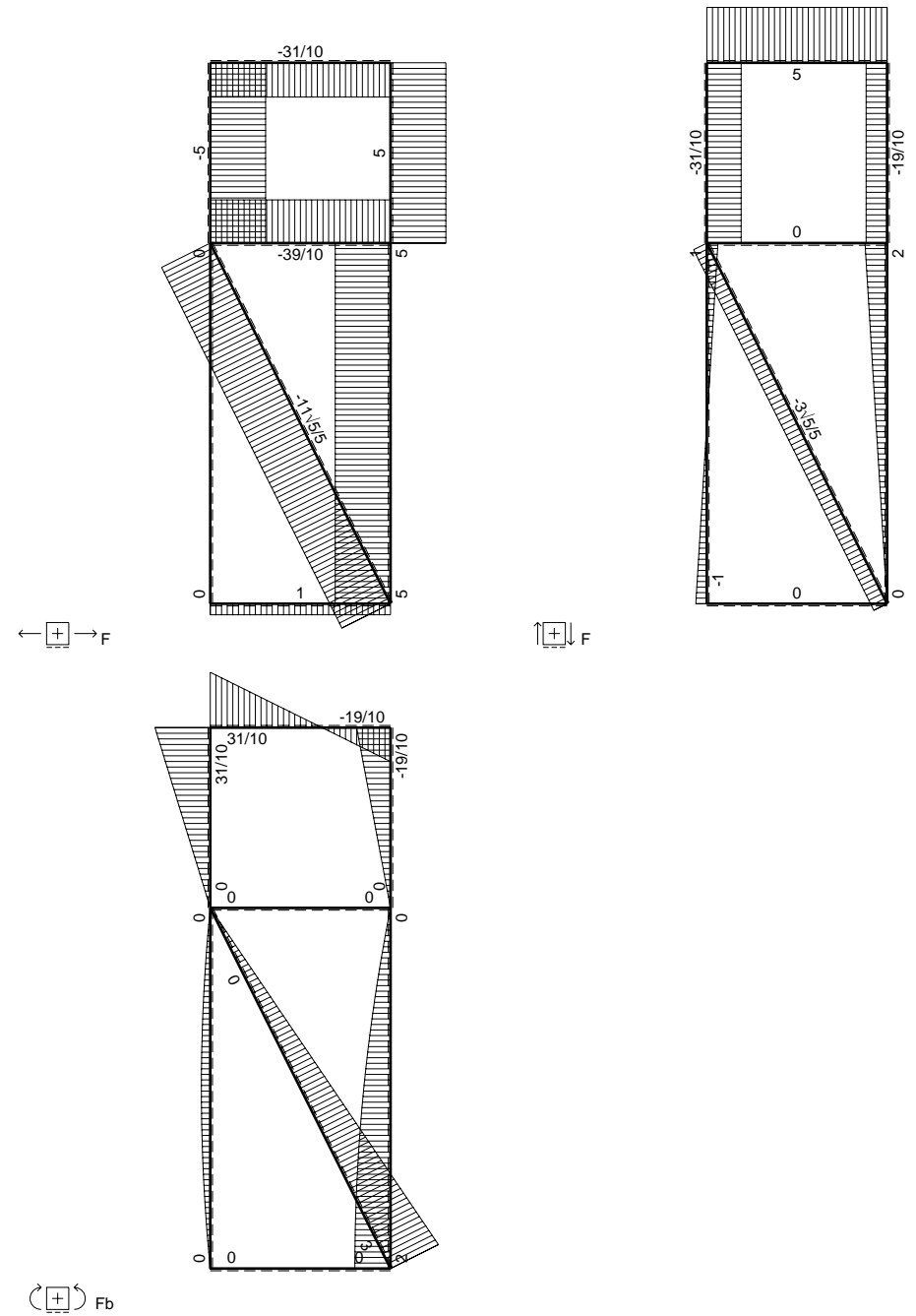
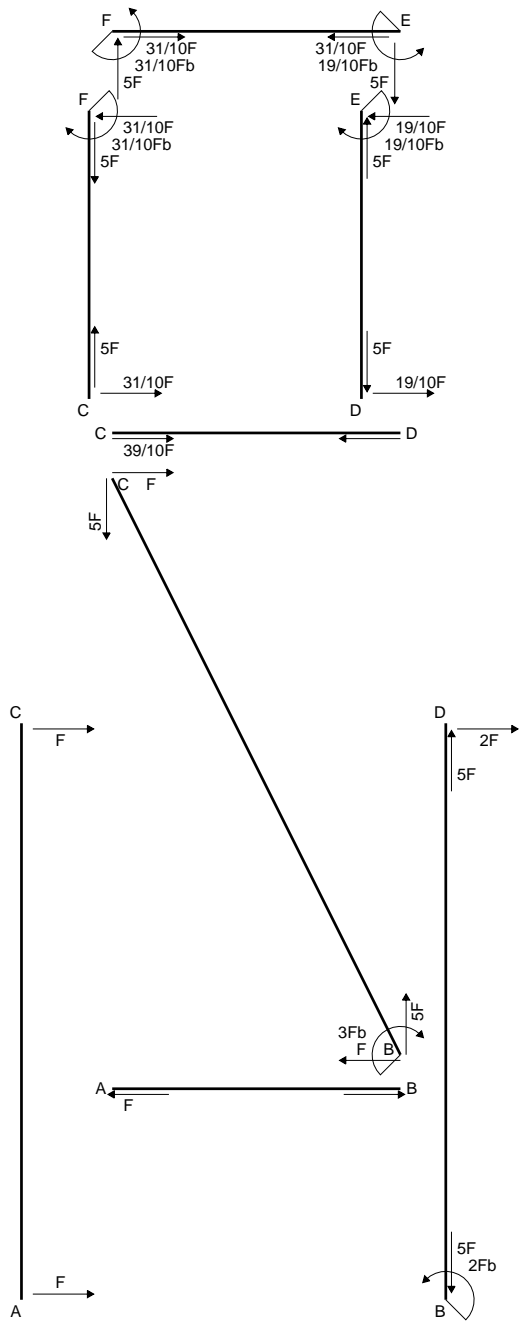

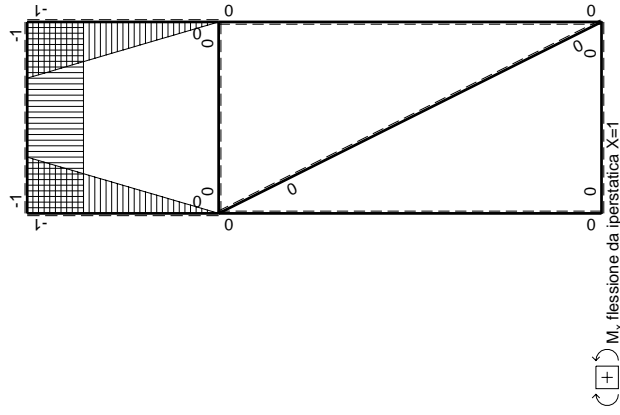
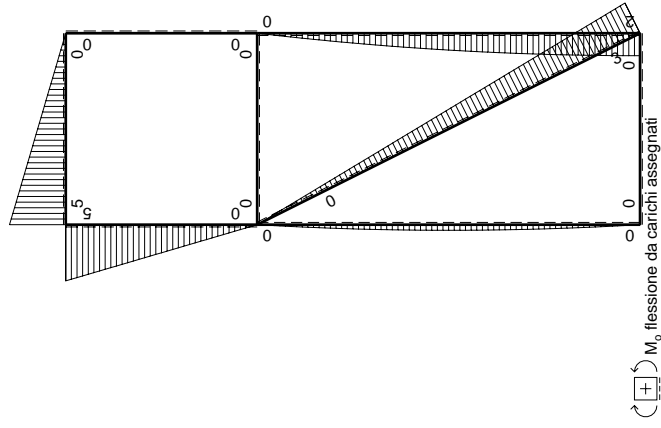
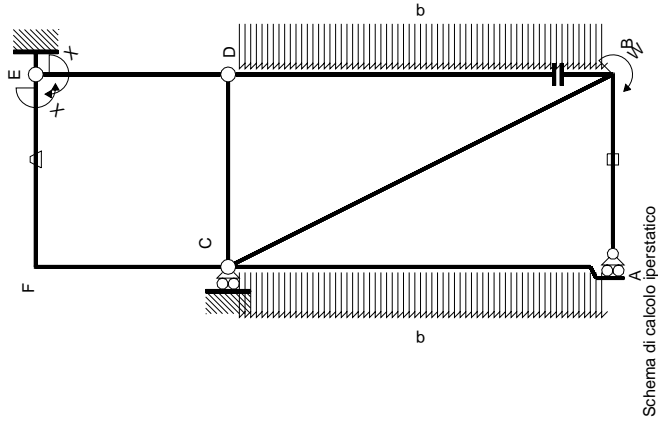

Quadro contributi PLV per iperstatica $X=W_{Ef}$

\rightarrow	$M^x(x)$	$M^0(x)$	θ	$M^x M_0$	$M^x \theta$	$M^x M_x$	$\int M^x (M_0/EJ + \theta) dx$	$\int M^x M_x / E J dx$
AB b	0	0	0	0	0	0	0	0
BA b	0	0	0	0	0	0	0	0
BC $\sqrt{5}b$	0	$3Fb-3\sqrt{5}/5Fx$	0	0	0	0	0	0
AC 2b	0	$-Fx+1/2qx^2$	0	0	0	0	0	0
CA 2b	0	$Fx-1/2qx^2$	0	0	0	0	0	0
DB 2b	0	$2Fx-1/2qx^2$	0	0	0	0	0	0
BD 2b	0	$-2Fb+1/2qx^2$	0	0	0	0	0	0
DE b	$-x/b$	0	0	0	0	x^2/b^2	0	$1/3Xb/EJ$
ED b	$1-x/b$	0	0	0	0	$1-2x/b+x^2/b^2$	0	$1/3Xb/EJ$
CD b	0	0	0	0	0	0	0	0
DC b	0	0	0	0	0	0	0	0
EF b	-1	$5Fx$	$-Fb/EJ$	$-5Fx$	Fb/EJ	1	$(-5/2+1)Fb^2/EJ$	Xb/EJ
FE b	1	$-5Fb+5Fx$	Fb/EJ	$-5Fb+5Fx$	Fb/EJ	1	$(-5/2+1)Fb^2/EJ$	Xb/EJ
FC b	$-1+x/b$	$5Fb-5Fx$	0	$-5Fb+10Fx-5Fx^2/b$	0	$1-2x/b+x^2/b^2$	$(-5/3+0)Fb^2/EJ$	$1/3Xb/EJ$
CF b	x/b	$-5Fx$	0	$-5Fx^2/b$	0	x^2/b^2	$-19/6Fb^2/EJ$	$5/3Xb/EJ$
totali								
								$19/10Fb$

Sviluppi di calcolo iperstatica

$$L_{DE}^{xx} = \int_0^b (x^2/b^2) 1/EJ dx = [1/3 x^3/b^2]_0^b 1/EJ$$

$$= (1/3 b) 1/EJ = 1/3 b/EJ$$

$$L_{ED}^{xx} = \int_0^b (1 - 2x/b + x^2/b^2) 1/EJ dx = [x - x^2/b + 1/3 x^3/b^2]_0^b 1/EJ$$

$$= (b - b + 1/3 b) 1/EJ = 1/3 b/EJ$$

$$L_{EF}^{xx} = \int_0^b (1) 1/EJ dx = [x]_0^b 1/EJ$$

$$= (b) 1/EJ = b/EJ$$

$$L_{FE}^{xx} = \int_0^b (1) 1/EJ dx = [x]_0^b 1/EJ$$

$$= (b) 1/EJ = b/EJ$$

$$L_{FC}^{xx} = \int_0^b (1 - 2x/b + x^2/b^2) 1/EJ dx = [x - x^2/b + 1/3 x^3/b^2]_0^b 1/EJ$$

$$= (b - b + 1/3 b) 1/EJ = 1/3 b/EJ$$

$$L_{CF}^{xx} = \int_0^b (x^2/b^2) 1/EJ dx = [1/3 x^3/b^2]_0^b 1/EJ$$

$$= (1/3 b) 1/EJ = 1/3 b/EJ$$

$$L_{EF}^{xo} = \int_0^b (-5x/b) Fb 1/EJ dx + \int_0^b (1) \theta dx = [-5/2 x^2/b]_0^b Fb 1/EJ + [x]_0^b \theta$$

$$= (-5/2 b) Fb 1/EJ + (b) \theta = -3/2 Fb^2/EJ$$

$$L_{FE}^{xo} = \int_0^b (-5 + 5x/b) Fb 1/EJ dx + \int_0^b (-1) \theta dx = [-5x + 5/2 x^2/b]_0^b Fb 1/EJ + [-x]_0^b \theta$$

$$= (-5b + 5/2 b) Fb 1/EJ + (-b) \theta = -3/2 Fb^2/EJ$$

$$L_{FC}^{xo} = \int_0^b (-5 + 10x/b - 5x^2/b^2) Fb 1/EJ dx = [-5x + 5x^2/b - 5/3 x^3/b^2]_0^b Fb 1/EJ$$

$$= (-5b + 5b - 5/3 b) Fb 1/EJ = -5/3 Fb^2/EJ$$

$$L_{CF}^{xo} = \int_0^b (-5x^2/b^2) Fb 1/EJ dx = [-5/3 x^3/b^2]_0^b Fb 1/EJ$$

$$= (-5/3 b) Fb 1/EJ = -5/3 Fb^2/EJ$$

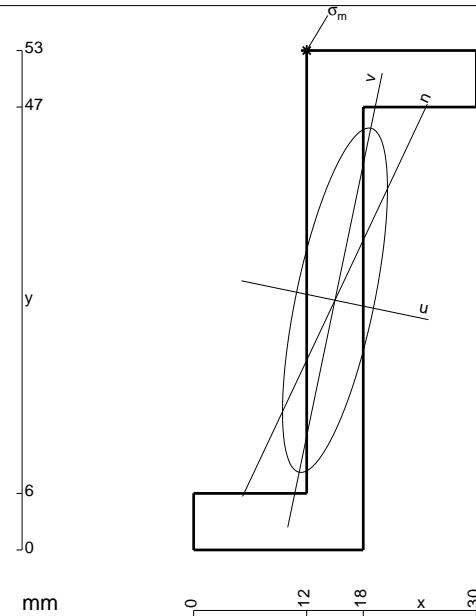

$$A = 462. \text{ mm}^2$$

$$J_x = 154395. \text{ mm}^4$$

$$J_y = 14346. \text{ mm}^4$$

$$J_{xy} = 30456. \text{ mm}^4$$

$$J_u = 160731. \text{ mm}^4$$

$$J_v = 8010. \text{ mm}^4$$

$$\alpha = \text{artg}(2J_{xy}/(J_y - J_x))/2 = -.2051$$

$$c = \cos \alpha = .9790$$

$$s = \sin \alpha = -.2037$$

$$x_g = 15. \text{ mm}$$

$$y_g = 26.5 \text{ mm}$$

$$N = -2150. \text{ N}$$

$$T_y = -1333. \text{ N}$$

$$M_x = 586520. \text{ Nmm}$$

$$x_m = 12. \text{ mm}$$

$$y_m = 53. \text{ mm}$$

$$u_m = -8.335 \text{ mm}$$

$$v_m = 25.33 \text{ mm}$$

$$\sigma_m = N/A - Mcv/J_u - Msu/J_v = -219.5 \text{ N/mm}^2$$

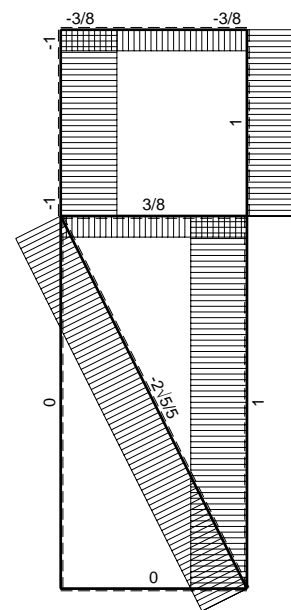
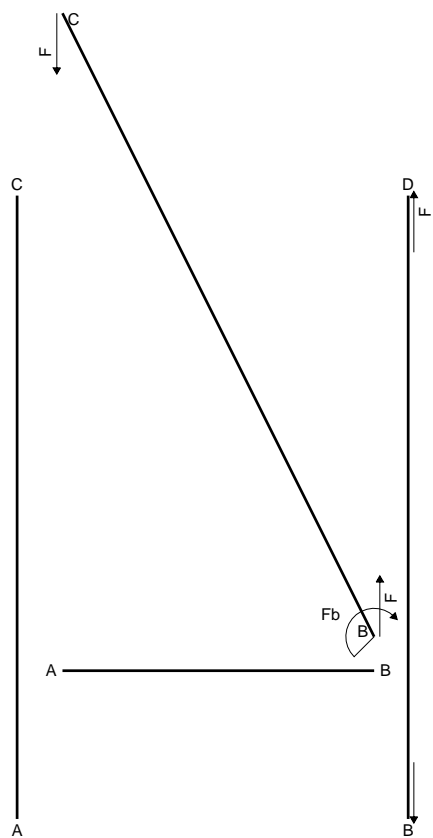
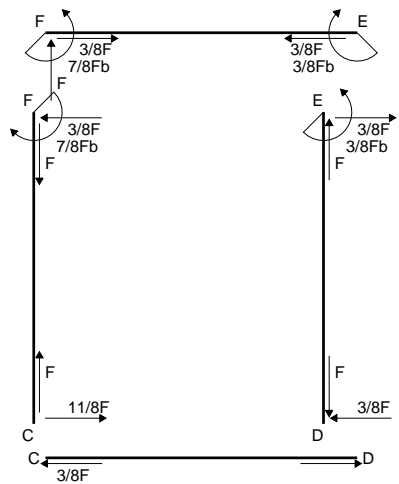

← ⊕ → F

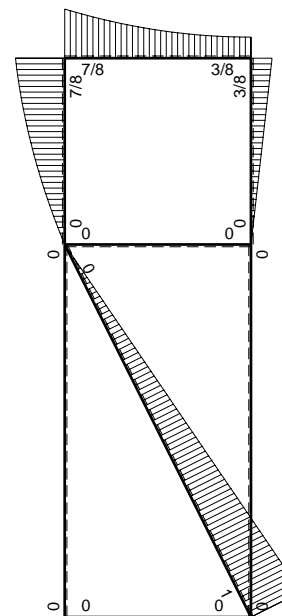

⊕ ⊖ F_b

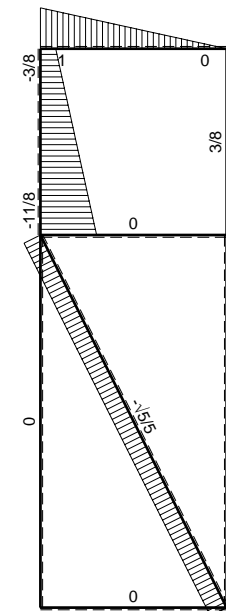

↑ ⊕ ↓ F

$$L_{DE}^{xx} = \int_0^b (x^2/b^2) 1/EJ dx = [1/3 x^3/b^2]_0^b 1/EJ$$

$$= (1/3 b) 1/EJ = 1/3 b/EJ$$

$$L_{ED}^{xx} = \int_0^b (1 - 2x/b + x^2/b^2) 1/EJ dx = [x - x^2/b + 1/3 x^3/b^2]_0^b 1/EJ$$

$$= (b - b + 1/3 b) 1/EJ = 1/3 b/EJ$$

$$L_{EF}^{xx} = \int_0^b (1) 1/EJ dx = [x]_0^b 1/EJ$$

$$= (b) 1/EJ = b/EJ$$

$$L_{FE}^{xx} = \int_0^b (1) 1/EJ dx = [x]_0^b 1/EJ$$

$$= (b) 1/EJ = b/EJ$$

$$L_{FC}^{xx} = \int_0^b (1 - 2x/b + x^2/b^2) 1/EJ dx = [x - x^2/b + 1/3 x^3/b^2]_0^b 1/EJ$$

$$= (b - b + 1/3 b) 1/EJ = 1/3 b/EJ$$

$$L_{CF}^{xx} = \int_0^b (x^2/b^2) 1/EJ dx = [1/3 x^3/b^2]_0^b 1/EJ$$

$$= (1/3 b) 1/EJ = 1/3 b/EJ$$

$$L_{EF}^{xo} = \int_0^b (-1/2 x^2/b^2) Fb 1/EJ dx + \int_0^b (1) \theta dx = [-1/6 x^3/b^2]_0^b Fb 1/EJ + [x]_0^b \theta$$

$$= (-1/6 b) Fb 1/EJ + (b) \theta = 5/6 Fb^2/EJ$$

$$L_{FE}^{xo} = \int_0^b (-1/2 + x/b - 1/2 x^2/b^2) Fb 1/EJ dx + \int_0^b (-1) \theta dx$$

$$= [-1/2 x + 1/2 x^2/b - 1/6 x^3/b^2]_0^b Fb 1/EJ + [-x]_0^b \theta$$

$$= (-1/2 b + 1/2 b - 1/6 b) Fb 1/EJ + (-b) \theta = 5/6 Fb^2/EJ$$

$$L_{FC}^{xo} = \int_0^b (-1/2 + 1/2 x/b + 1/2 x^2/b^2 - 1/2 x^3/b^3) Fb 1/EJ dx$$

$$= [-1/2 x + 1/4 x^2/b + 1/6 x^3/b^2 - 1/8 x^4/b^3]_0^b Fb 1/EJ$$

$$= (-1/2 b + 1/4 b + 1/6 b - 1/8 b) Fb 1/EJ = -5/24 Fb^2/EJ$$

$$L_{CF}^{xo} = \int_0^b (-x^2/b^2 + 1/2 x^3/b^3) Fb 1/EJ dx = [-1/3 x^3/b^2 + 1/8 x^4/b^3]_0^b Fb 1/EJ$$

$$= (-1/3 b + 1/8 b) Fb 1/EJ = -5/24 Fb^2/EJ$$

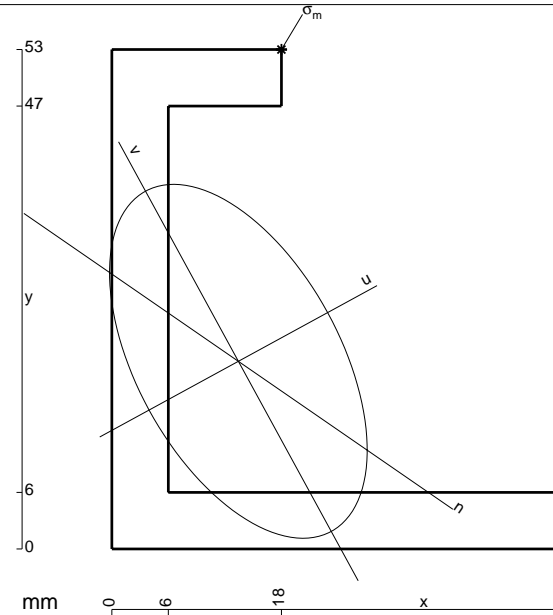

- A = 642. mm²
- J_x = 226469. mm⁴
- J_y = 120007. mm⁴
- J_{xy} = -82782. mm⁴
- J_u = 271657. mm⁴
- J_v = 74819. mm⁴
- α = arctg(2J_{xy}/(J_v-J_x))/2 = .4997
- c = cosα = .8777
- s = sinα = .4791
- x_g = 13.43 mm
- y_g = 19.91 mm
- N = -1968. N
- T_y = -983.9 N
- M_x = 1056000. Nmm
- x_m = 18. mm
- y_m = 53. mm
- u_m = 19.87 mm
- v_m = 26.85 mm
- σ_m = N/A-Mcv/J_u-Msu/J_v = -229. N/mm²

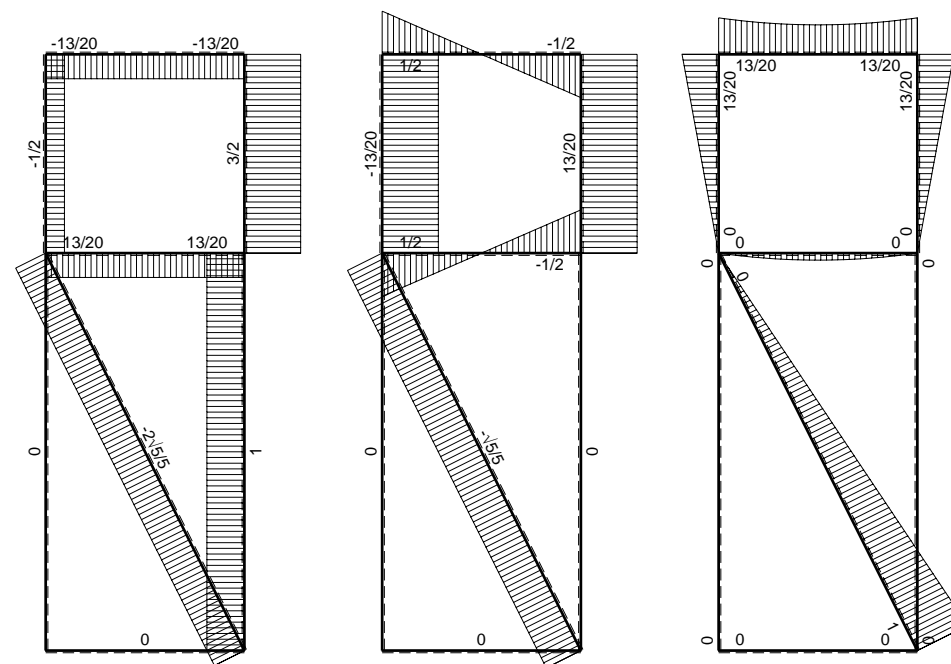
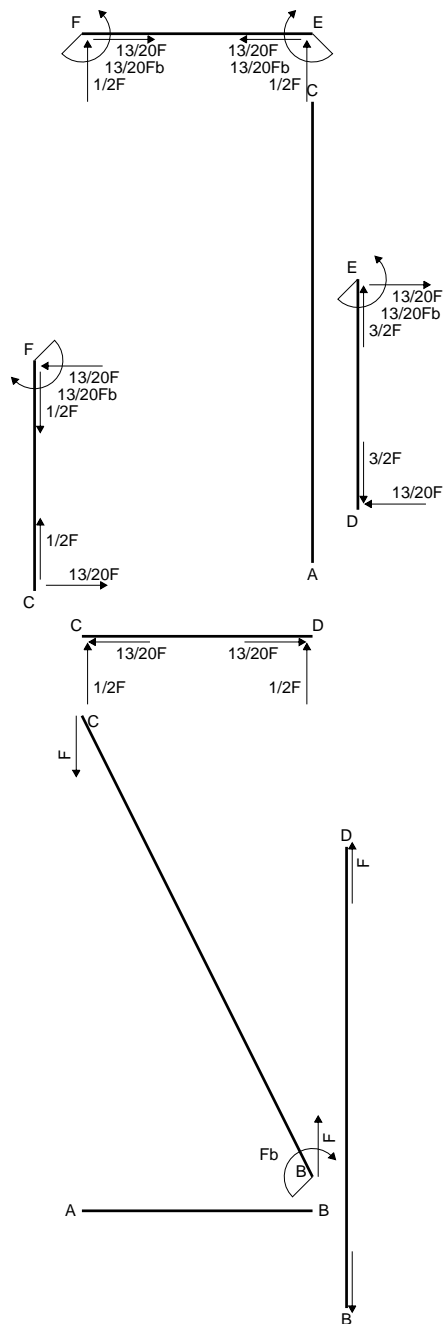

← ⊕ → F

↑ ⊕ ↓ F

⊕ ⊖ F_b

$$L_{DE}^{xx} = \int_0^b (x^2/b^2) 1/EJ dx = [1/3 x^3/b^2]_0^b 1/EJ$$

$$= (1/3 b) 1/EJ = 1/3 b/EJ$$

$$L_{ED}^{xx} = \int_0^b (1 - 2x/b + x^2/b^2) 1/EJ dx = [x - x^2/b + 1/3 x^3/b^2]_0^b 1/EJ$$

$$= (b - b + 1/3 b) 1/EJ = 1/3 b/EJ$$

$$L_{EF}^{xx} = \int_0^b (1) 1/EJ dx = [x]_0^b 1/EJ$$

$$= (b) 1/EJ = b/EJ$$

$$L_{FE}^{xx} = \int_0^b (1) 1/EJ dx = [x]_0^b 1/EJ$$

$$= (b) 1/EJ = b/EJ$$

$$L_{FC}^{xx} = \int_0^b (1 - 2x/b + x^2/b^2) 1/EJ dx = [x - x^2/b + 1/3 x^3/b^2]_0^b 1/EJ$$

$$= (b - b + 1/3 b) 1/EJ = 1/3 b/EJ$$

$$L_{CF}^{xx} = \int_0^b (x^2/b^2) 1/EJ dx = [1/3 x^3/b^2]_0^b 1/EJ$$

$$= (1/3 b) 1/EJ = 1/3 b/EJ$$

$$L_{EF}^{xo} = \int_0^b (1/2 x/b - 1/2 x^2/b^2) Fb 1/EJ dx + \int_0^b (1) \theta dx = [1/4 x^2/b - 1/6 x^3/b^2]_0^b Fb 1/EJ + [x]_0^b \theta$$

$$= (1/4 b - 1/6 b) Fb 1/EJ + (b) \theta = 13/12 Fb^2/EJ$$

$$L_{FE}^{xo} = \int_0^b (1/2 x/b - 1/2 x^2/b^2) Fb 1/EJ dx + \int_0^b (-1) \theta dx = [1/4 x^2/b - 1/6 x^3/b^2]_0^b Fb 1/EJ + [-x]_0^b \theta$$

$$= (1/4 b - 1/6 b) Fb 1/EJ + (-b) \theta = 13/12 Fb^2/EJ$$

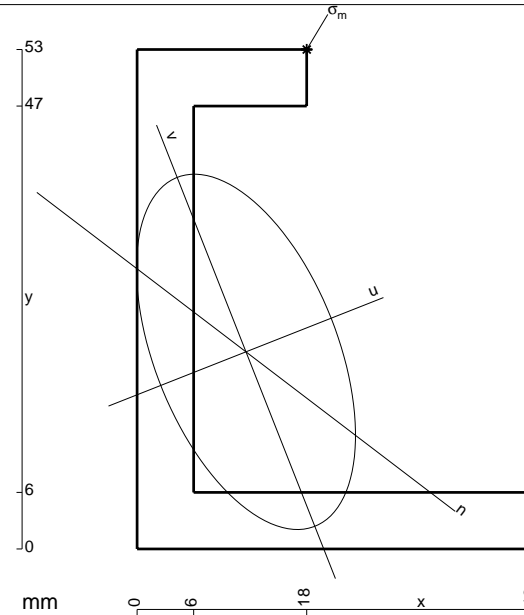

- A = 606. mm²
- J_x = 215454. mm⁴
- J_y = 81888. mm⁴
- J_{xy} = -62420. mm⁴
- J_u = 240083. mm⁴
- J_v = 57259. mm⁴
- α = arctg(2J_{xy}/(J_y-J_x))/2 = .3758
- c = cos α = .9302
- s = sin α = .3670
- x_g = 11.55 mm
- y_g = 20.92 mm
- N = -1878. N
- T_y = -939.1 N
- M_x = 1071000. Nmm
- x_m = 18. mm
- y_m = 53. mm
- u_m = 17.77 mm
- v_m = 27.48 mm
- σ_m = N/A - Mcv/J_u - Msu/J_v = -239.1 N/mm²

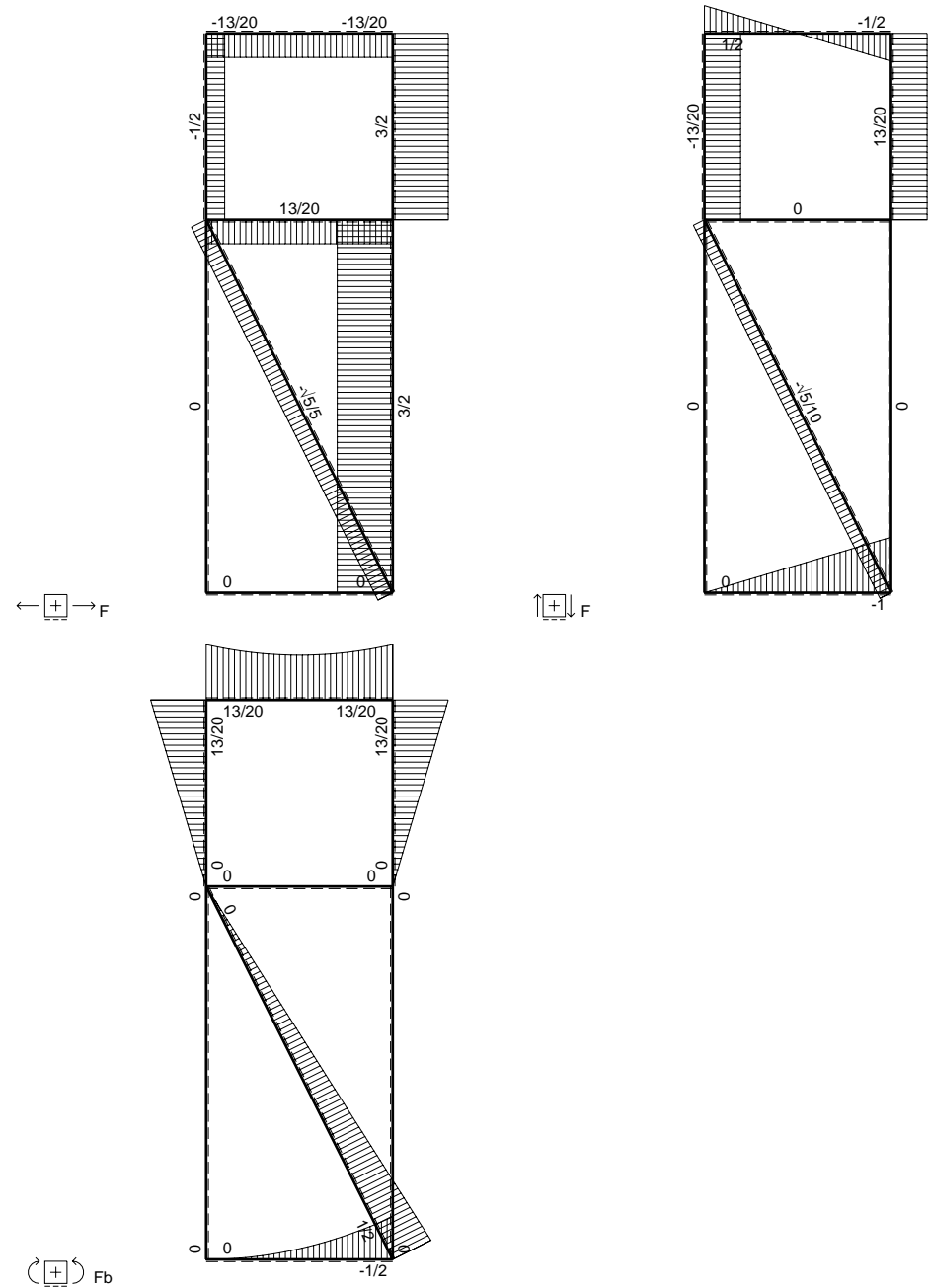
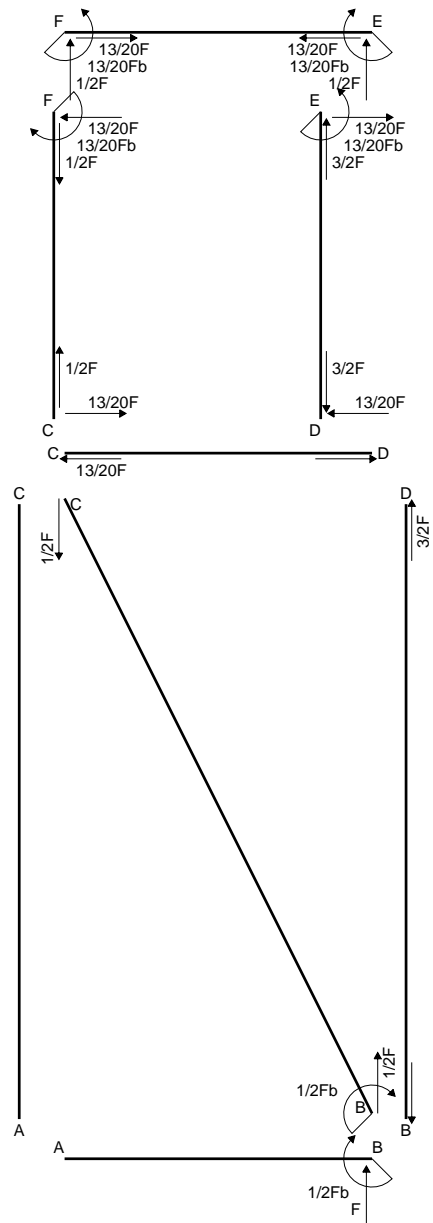

$$L_{DE}^{xx} = \int_0^b (x^2/b^2) 1/EJ dx = [1/3 x^3/b^2]_0^b 1/EJ$$

$$= (1/3 b) 1/EJ = 1/3 b/EJ$$

$$L_{ED}^{xx} = \int_0^b (1 - 2x/b + x^2/b^2) 1/EJ dx = [x - x^2/b + 1/3 x^3/b^2]_0^b 1/EJ$$

$$= (b - b + 1/3 b) 1/EJ = 1/3 b/EJ$$

$$L_{EF}^{xx} = \int_0^b (1) 1/EJ dx = [x]_0^b 1/EJ$$

$$= (b) 1/EJ = b/EJ$$

$$L_{FE}^{xx} = \int_0^b (1) 1/EJ dx = [x]_0^b 1/EJ$$

$$= (b) 1/EJ = b/EJ$$

$$L_{FC}^{xx} = \int_0^b (1 - 2x/b + x^2/b^2) 1/EJ dx = [x - x^2/b + 1/3 x^3/b^2]_0^b 1/EJ$$

$$= (b - b + 1/3 b) 1/EJ = 1/3 b/EJ$$

$$L_{CF}^{xx} = \int_0^b (x^2/b^2) 1/EJ dx = [1/3 x^3/b^2]_0^b 1/EJ$$

$$= (1/3 b) 1/EJ = 1/3 b/EJ$$

$$L_{EF}^{xo} = \int_0^b (1/2 x/b - 1/2 x^2/b^2) Fb 1/EJ dx + \int_0^b (1) \theta dx = [1/4 x^2/b - 1/6 x^3/b^2]_0^b Fb 1/EJ + [x]_0^b \theta$$

$$= (1/4 b - 1/6 b) Fb 1/EJ + (b) \theta = 13/12 Fb^2/EJ$$

$$L_{FE}^{xo} = \int_0^b (1/2 x/b - 1/2 x^2/b^2) Fb 1/EJ dx + \int_0^b (-1) \theta dx = [1/4 x^2/b - 1/6 x^3/b^2]_0^b Fb 1/EJ + [-x]_0^b \theta$$

$$= (1/4 b - 1/6 b) Fb 1/EJ + (-b) \theta = 13/12 Fb^2/EJ$$

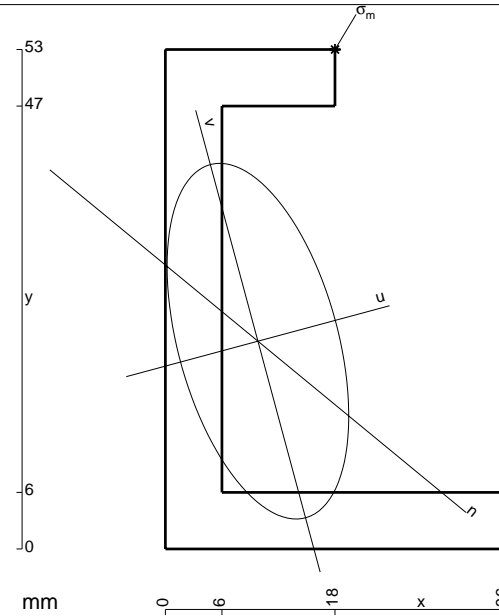

- A = 570. mm²
- J_x = 203061. mm⁴
- J_y = 52950. mm⁴
- J_{xy} = -43600. mm⁴
- J_u = 214806. mm⁴
- J_v = 41205. mm⁴
- α = artg(2J_{xy}/(J_y-J_x))/2 = .2631
- c = cosα = .9656
- s = sinα = .2601
- x_g = 9.821 mm
- y_g = 22.05 mm
- N = -1586. N
- T_y = -1220. N
- M_x = 872300. Nmm
- x_m = 18. mm
- y_m = 53. mm
- u_m = 15.95 mm
- v_m = 27.76 mm
- σ_m = N/A - Mc_v/J_u - Ms_u/J_v = -199.4 N/mm²

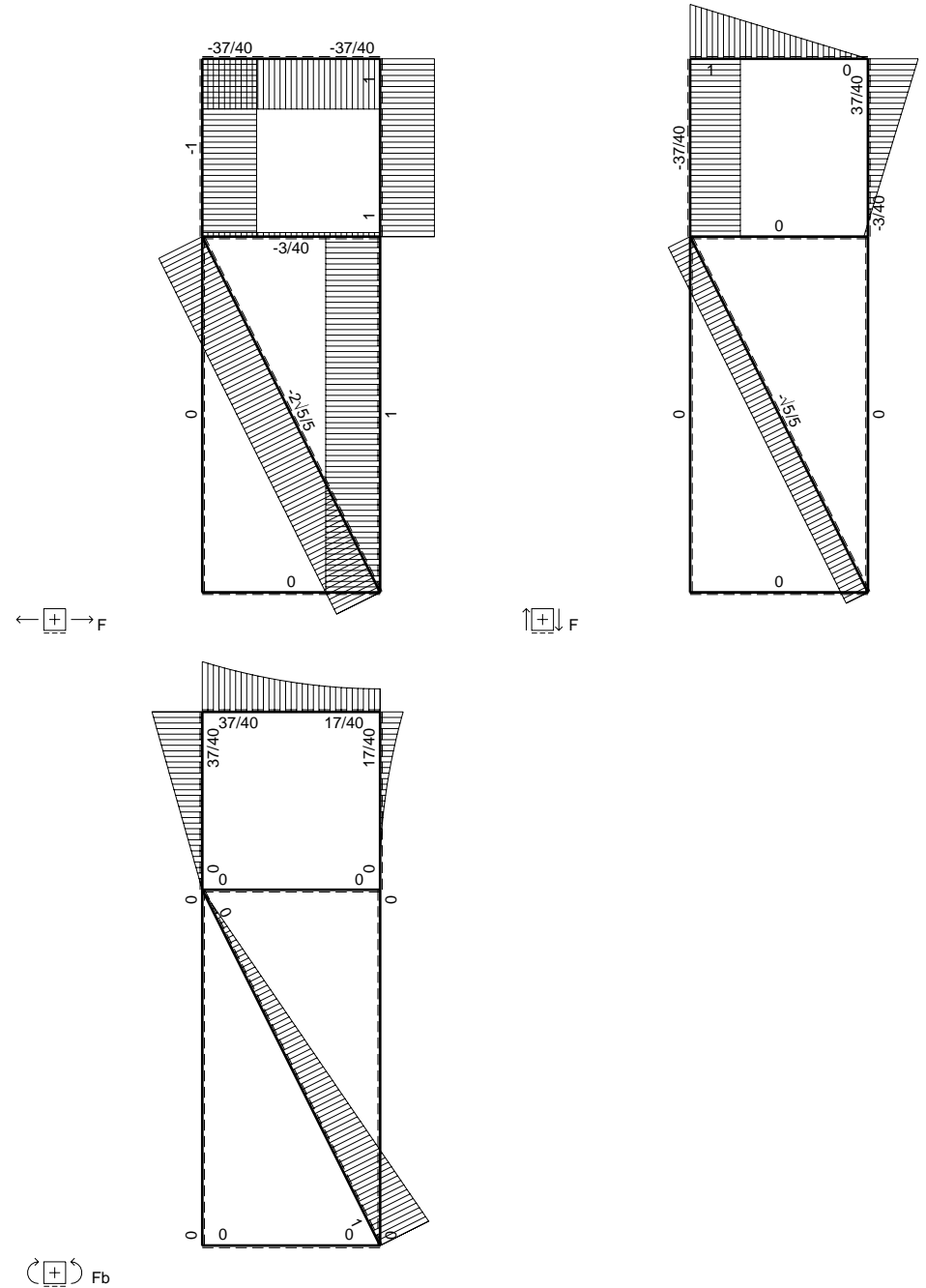
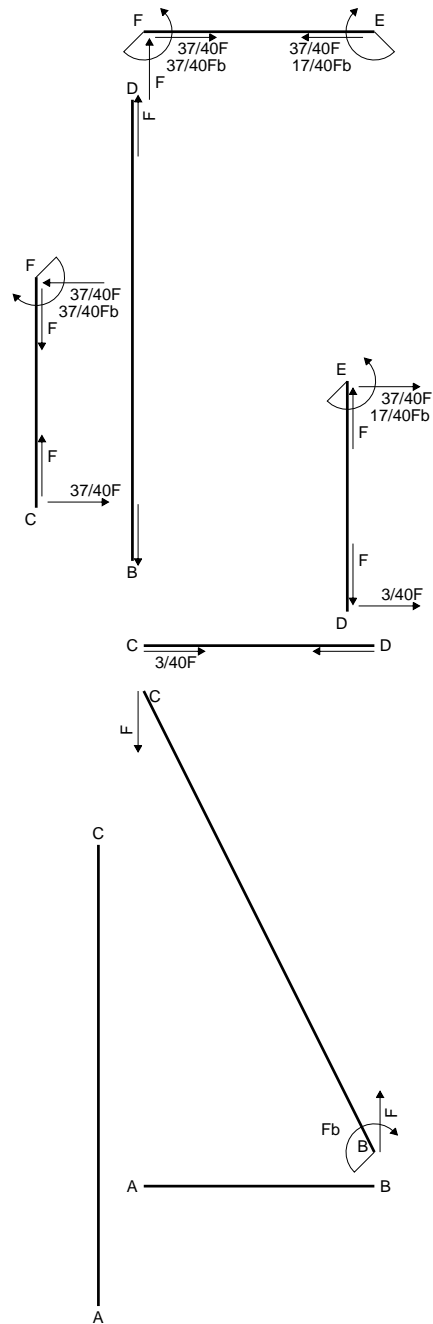

$$L_{DE}^{xx} = \int_0^b (x^2/b^2) 1/EJ dx = [1/3 x^3/b^2]_0^b 1/EJ$$

$$= (1/3 b) 1/EJ = 1/3 b/EJ$$

$$L_{ED}^{xx} = \int_0^b (1 - 2x/b + x^2/b^2) 1/EJ dx = [x - x^2/b + 1/3 x^3/b^2]_0^b 1/EJ$$

$$= (b - b + 1/3 b) 1/EJ = 1/3 b/EJ$$

$$L_{EF}^{xx} = \int_0^b (1) 1/EJ dx = [x]_0^b 1/EJ$$

$$= (b) 1/EJ = b/EJ$$

$$L_{FE}^{xx} = \int_0^b (1) 1/EJ dx = [x]_0^b 1/EJ$$

$$= (b) 1/EJ = b/EJ$$

$$L_{FC}^{xx} = \int_0^b (1 - 2x/b + x^2/b^2) 1/EJ dx = [x - x^2/b + 1/3 x^3/b^2]_0^b 1/EJ$$

$$= (b - b + 1/3 b) 1/EJ = 1/3 b/EJ$$

$$L_{CF}^{xx} = \int_0^b (x^2/b^2) 1/EJ dx = [1/3 x^3/b^2]_0^b 1/EJ$$

$$= (1/3 b) 1/EJ = 1/3 b/EJ$$

$$L_{DE}^{xo} = \int_0^b (1/2 x^2/b^2 - 1/2 x^3/b^3) Fb 1/EJ dx = [1/6 x^3/b^2 - 1/8 x^4/b^3]_0^b Fb 1/EJ$$

$$= (1/6 b - 1/8 b) Fb 1/EJ = 1/24 Fb^2/EJ$$

$$L_{ED}^{xo} = \int_0^b (1/2 x/b - x^2/b^2 + 1/2 x^3/b^3) Fb 1/EJ dx = [1/4 x^2/b - 1/3 x^3/b^2 + 1/8 x^4/b^3]_0^b Fb 1/EJ$$

$$= (1/4 b - 1/3 b + 1/8 b) Fb 1/EJ = 1/24 Fb^2/EJ$$

$$L_{EF}^{xo} = \int_0^b (-1/2 x^2/b^2) Fb 1/EJ dx + \int_0^b (1) \theta dx = [-1/6 x^3/b^2]_0^b Fb 1/EJ + [x]_0^b \theta$$

$$= (-1/6 b) Fb 1/EJ + (b) \theta = 5/6 Fb^2/EJ$$

$$L_{FE}^{xo} = \int_0^b (-1/2 + x/b - 1/2 x^2/b^2) Fb 1/EJ dx + \int_0^b (-1) \theta dx$$

$$= [-1/2 x + 1/2 x^2/b - 1/6 x^3/b^2]_0^b Fb 1/EJ + [-x]_0^b \theta$$

$$= (-1/2 b + 1/2 b - 1/6 b) Fb 1/EJ + (-b) \theta = 5/6 Fb^2/EJ$$

$$L_{FC}^{xo} = \int_0^b (-1/2 + x/b - 1/2 x^2/b^2) Fb 1/EJ dx = [-1/2 x + 1/2 x^2/b - 1/6 x^3/b^2]_0^b Fb 1/EJ$$

$$= (-1/2 b + 1/2 b - 1/6 b) Fb 1/EJ = -1/6 Fb^2/EJ$$

$$L_{CF}^{xo} = \int_0^b (-1/2 x^2/b^2) Fb 1/EJ dx = [-1/6 x^3/b^2]_0^b Fb 1/EJ$$

$$= (-1/6 b) Fb 1/EJ = -1/6 Fb^2/EJ$$

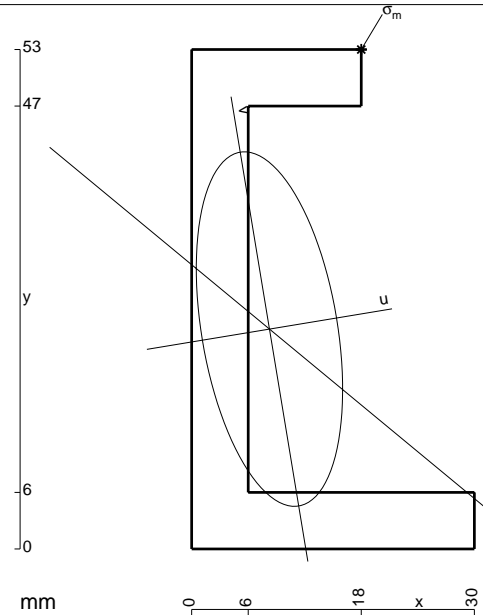

- A = 534. mm²
- J_x = 189011. mm⁴
- J_y = 32196. mm⁴
- J_{xy} = -26635. mm⁴
- J_u = 193412. mm⁴
- J_v = 27796. mm⁴
- α = arctg(2J_{xy}/(J_y-J_x))/2 = .1637
- c = cos α = .9866
- s = sin α = .1630
- x_g = 8.258 mm
- y_g = 23.33 mm
- N = -1386. N
- T_y = -693.2 N
- M_x = 914500. Nmm
- x_m = 18. mm
- y_m = 53. mm
- u_m = 14.45 mm
- v_m = 27.68 mm
- σ_m = N/A - Mc_v/J_u - Ms_u/J_v = -209.2 N/mm²

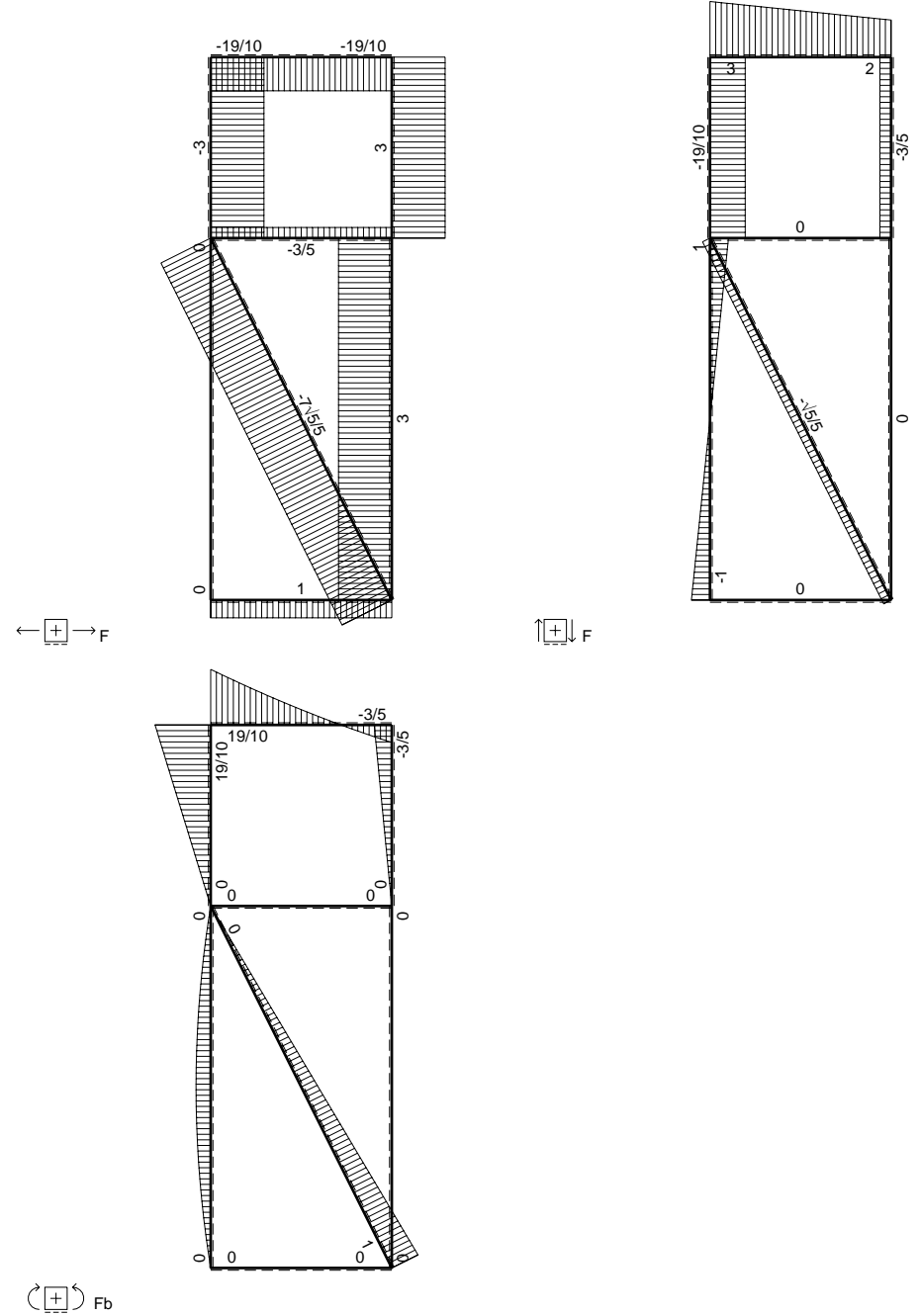
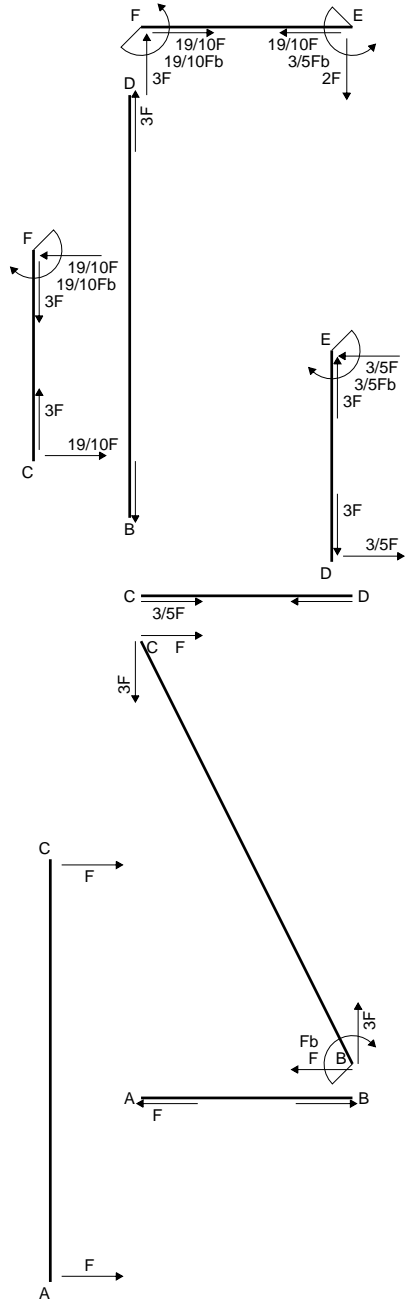

$$L_{DE}^{xx} = \int_0^b (x^2/b^2) 1/EJ dx = [1/3 x^3/b^2]_0^b 1/EJ$$

$$= (1/3 b) 1/EJ = 1/3 b/EJ$$

$$L_{ED}^{xx} = \int_0^b (1 - 2x/b + x^2/b^2) 1/EJ dx = [x - x^2/b + 1/3 x^3/b^2]_0^b 1/EJ$$

$$= (b - b + 1/3 b) 1/EJ = 1/3 b/EJ$$

$$L_{EF}^{xx} = \int_0^b (1) 1/EJ dx = [x]_0^b 1/EJ$$

$$= (b) 1/EJ = b/EJ$$

$$L_{FE}^{xx} = \int_0^b (1) 1/EJ dx = [x]_0^b 1/EJ$$

$$= (b) 1/EJ = b/EJ$$

$$L_{FC}^{xx} = \int_0^b (1 - 2x/b + x^2/b^2) 1/EJ dx = [x - x^2/b + 1/3 x^3/b^2]_0^b 1/EJ$$

$$= (b - b + 1/3 b) 1/EJ = 1/3 b/EJ$$

$$L_{CF}^{xx} = \int_0^b (x^2/b^2) 1/EJ dx = [1/3 x^3/b^2]_0^b 1/EJ$$

$$= (1/3 b) 1/EJ = 1/3 b/EJ$$

$$L_{EF}^{xo} = \int_0^b (-2x/b - 1/2 x^2/b^2) Fb 1/EJ dx + \int_0^b (1) \theta dx = [-x^2/b - 1/6 x^3/b^2]_0^b Fb 1/EJ + [x]_0^b \theta$$

$$= (-b - 1/6 b) Fb 1/EJ + (b) \theta = -1/6 Fb^2/EJ$$

$$L_{FE}^{xo} = \int_0^b (-5/2 + 3x/b - 1/2 x^2/b^2) Fb 1/EJ dx + \int_0^b (-1) \theta dx$$

$$= [-5/2 x + 3/2 x^2/b - 1/6 x^3/b^2]_0^b Fb 1/EJ + [-x]_0^b \theta$$

$$= (-5/2 b + 3/2 b - 1/6 b) Fb 1/EJ + (-b) \theta = -1/6 Fb^2/EJ$$

$$L_{FC}^{xo} = \int_0^b (-5/2 + 5x/b - 5/2 x^2/b^2) Fb 1/EJ dx = [-5/2 x + 5/2 x^2/b - 5/6 x^3/b^2]_0^b Fb 1/EJ$$

$$= (-5/2 b + 5/2 b - 5/6 b) Fb 1/EJ = -5/6 Fb^2/EJ$$

$$L_{CF}^{xo} = \int_0^b (-5/2 x^2/b^2) Fb 1/EJ dx = [-5/6 x^3/b^2]_0^b Fb 1/EJ$$

$$= (-5/6 b) Fb 1/EJ = -5/6 Fb^2/EJ$$

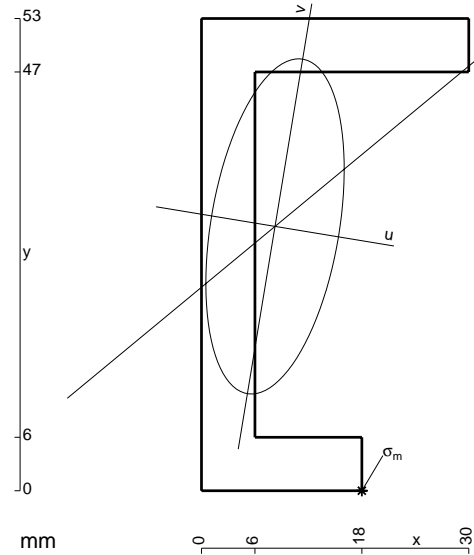

$A = 534. \text{ mm}^2$
 $J_x = 189011. \text{ mm}^4$
 $J_y = 32196. \text{ mm}^4$
 $J_{xy} = 26635. \text{ mm}^4$
 $J_u = 193412. \text{ mm}^4$
 $J_v = 27796. \text{ mm}^4$
 $\alpha = \text{artg}(2J_{xy}/(J_y - J_x))/2 = -.1637$
 $c = \cos \alpha = .9866$
 $s = \sin \alpha = -.1630$
 $x_g = 8.258 \text{ mm}$
 $y_g = 29.67 \text{ mm}$
 $N = -1577. \text{ N}$
 $T_y = 2490. \text{ N}$
 $M_x = 977740. \text{ Nmm}$
 $x_m = 18. \text{ mm}$
 $u_m = 14.45 \text{ mm}$
 $v_m = -27.68 \text{ mm}$
 $\sigma_m = N/A - Mcv/J_u - Msu/J_v = 218. \text{ N/mm}^2$

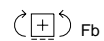
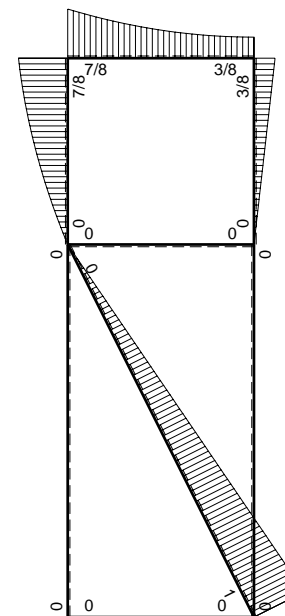
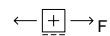
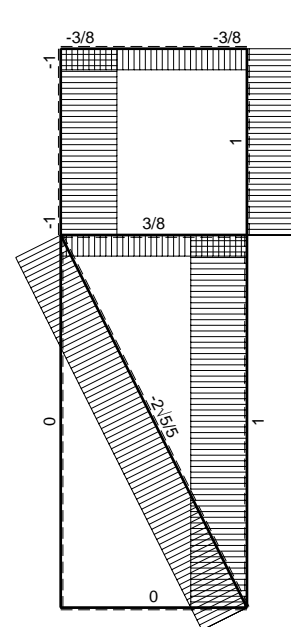
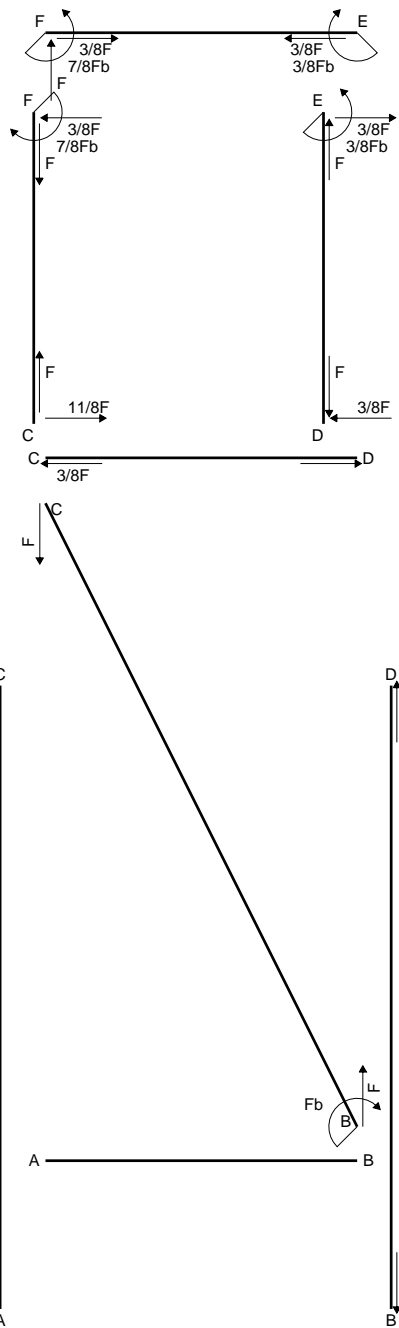

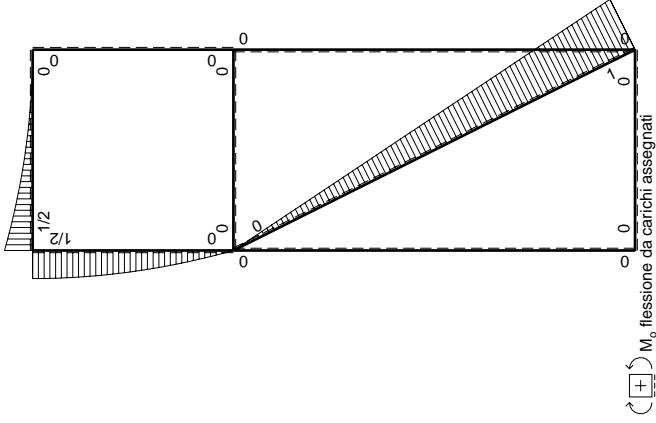
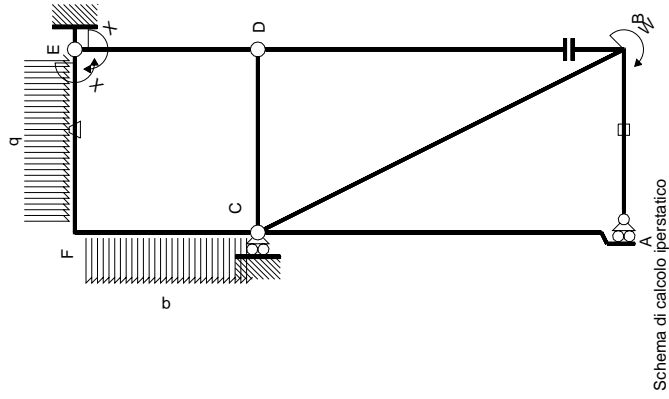

Quadro contributi PLV per iperstatica X=W^{EF}

←	M _x (x)	M ₀ (x)	θ	M _x θ	M _x M ₀	∫ M _x (M ₀ /EJ+θ)dx	∫ M _x M ₀ /EJdx
AB	0	0	0	0	0	0+0	0
BA	0	0	0	0	0	0	0
BC	0	Fb-√5/5Fx	0	0	0	0+0	0
AC	0	0	0	0	0	0+0	0
CA	0	0	0	0	0	0	0
DB	0	0	0	0	0	0+0	0
BD	0	0	0	0	0	0+0	0
DE	-x/b	0	0	0	0	x ² /b ²	1/3Xb/EJ
ED	1-x/b	0	0	0	0	1-2x/b+x ² /b ²	1/3Xb/EJ
CD	0	0	0	0	0	0	0
DC	0	0	0	0	0	0	0
EF	-1	1/2qx ²	-Fb/EJ	-1/2Fx ² /b	Fb/EJ	1	Xb/EJ
FE	1	-1/2Fb+Fx-1/2qx ²	Fb/EJ	-1/2Fx ² /b	Fb/EJ	1	(-1/6+1)Fb ² /EJ
FC	-1+x/b	1/2Fb-1/2qx ²	0	-1/2Fb+Fx-1/2Fx ² /b	0	1-2x/b+x ² /b ²	1/3Xb/EJ
CF	x/b	-Fx+1/2qx ²	0	-1/2Fb+1/2Fx+1/2Fx ² /b-1/2qx ³ /b	0	x ² /b ²	1/3Xb/EJ
totali							
							5/8Fb ² /EJ
							-3/8Fb

Sviluppi di calcolo iperstatica

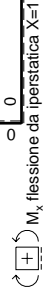

$$L_{DE}^{xx} = \int_0^b (x^2/b^2) 1/EJ dx = [1/3 x^3/b^2]_0^b 1/EJ$$

$$= (1/3 b) 1/EJ = 1/3 b/EJ$$

$$L_{ED}^{xx} = \int_0^b (1 - 2x/b + x^2/b^2) 1/EJ dx = [x - x^2/b + 1/3 x^3/b^2]_0^b 1/EJ$$

$$= (b - b + 1/3 b) 1/EJ = 1/3 b/EJ$$

$$L_{EF}^{xx} = \int_0^b (1) 1/EJ dx = [x]_0^b 1/EJ$$

$$= (b) 1/EJ = b/EJ$$

$$L_{FE}^{xx} = \int_0^b (1) 1/EJ dx = [x]_0^b 1/EJ$$

$$= (b) 1/EJ = b/EJ$$

$$L_{FC}^{xx} = \int_0^b (1 - 2x/b + x^2/b^2) 1/EJ dx = [x - x^2/b + 1/3 x^3/b^2]_0^b 1/EJ$$

$$= (b - b + 1/3 b) 1/EJ = 1/3 b/EJ$$

$$L_{CF}^{xx} = \int_0^b (x^2/b^2) 1/EJ dx = [1/3 x^3/b^2]_0^b 1/EJ$$

$$= (1/3 b) 1/EJ = 1/3 b/EJ$$

$$L_{EF}^{xo} = \int_0^b (-1/2 x^2/b^2) Fb 1/EJ dx + \int_0^b (1) \theta dx = [-1/6 x^3/b^2]_0^b Fb 1/EJ + [x]_0^b \theta$$

$$= (-1/6 b) Fb 1/EJ + (b) \theta = 5/6 Fb^2/EJ$$

$$L_{FE}^{xo} = \int_0^b (-1/2 + x/b - 1/2 x^2/b^2) Fb 1/EJ dx + \int_0^b (-1) \theta dx$$

$$= [-1/2 x + 1/2 x^2/b - 1/6 x^3/b^2]_0^b Fb 1/EJ + [-x]_0^b \theta$$

$$= (-1/2 b + 1/2 b - 1/6 b) Fb 1/EJ + (-b) \theta = 5/6 Fb^2/EJ$$

$$L_{FC}^{xo} = \int_0^b (-1/2 + 1/2 x/b + 1/2 x^2/b^2 - 1/2 x^3/b^3) Fb 1/EJ dx$$

$$= [-1/2 x + 1/4 x^2/b + 1/6 x^3/b^2 - 1/8 x^4/b^3]_0^b Fb 1/EJ$$

$$= (-1/2 b + 1/4 b + 1/6 b - 1/8 b) Fb 1/EJ = -5/24 Fb^2/EJ$$

$$L_{CF}^{xo} = \int_0^b (-x^2/b^2 + 1/2 x^3/b^3) Fb 1/EJ dx = [-1/3 x^3/b^2 + 1/8 x^4/b^3]_0^b Fb 1/EJ$$

$$= (-1/3 b + 1/8 b) Fb 1/EJ = -5/24 Fb^2/EJ$$

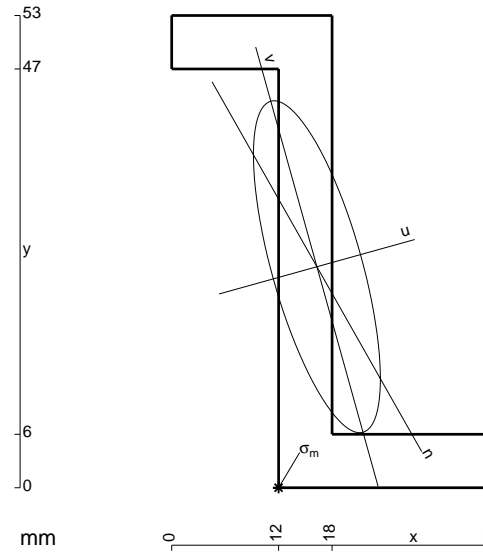

$$A = 498. \text{ mm}^2$$

$$J_x = 172946. \text{ mm}^4$$

$$J_y = 25275. \text{ mm}^4$$

$$J_{xy} = -44583. \text{ mm}^4$$

$$J_u = 185362. \text{ mm}^4$$

$$J_v = 12859. \text{ mm}^4$$

$$\alpha = \text{artg}(2J_{xy}/(J_y - J_x))/2 = .2716$$

$$c = \cos \alpha = .9633$$

$$s = \sin \alpha = .2683$$

$$x_g = 16.3 \text{ mm}$$

$$y_g = 24.8 \text{ mm}$$

$$N = -912.3 \text{ N}$$

$$T_y = -456.2 \text{ N}$$

$$M_x = 673200. \text{ Nmm}$$

$$x_m = 12. \text{ mm}$$

$$u_m = -10.8 \text{ mm}$$

$$v_m = -22.74 \text{ mm}$$

$$\sigma_m = N/A - Mcv/J_u - Msu/J_v = 229.4 \text{ N/mm}^2$$

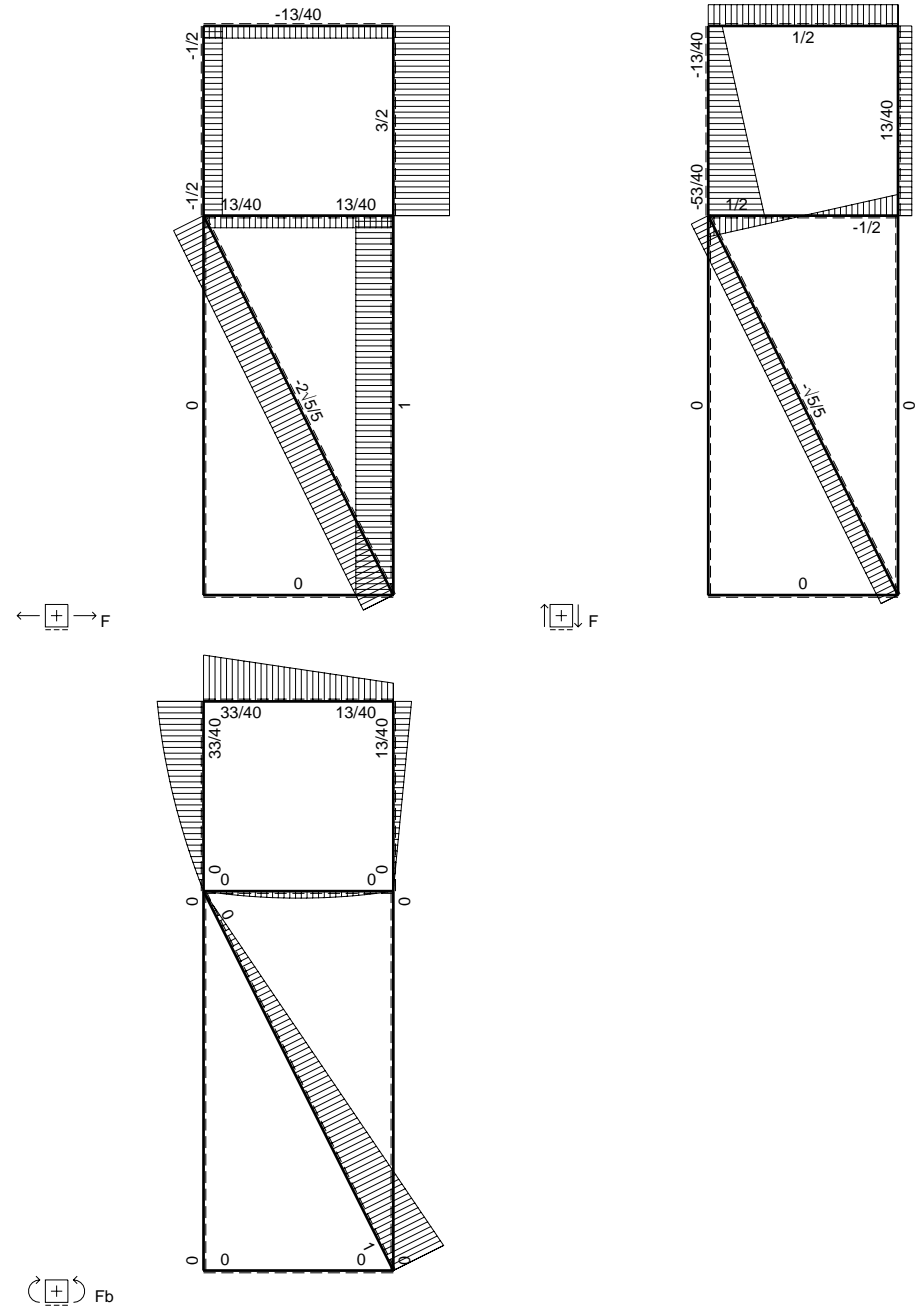
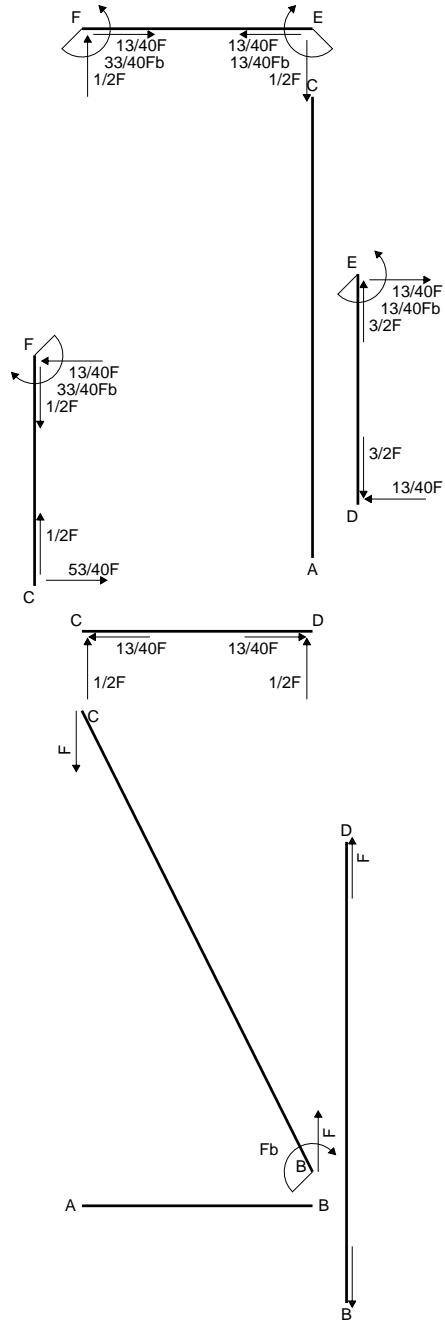

$$L_{DE}^{xx} = \int_0^b (x^2/b^2) 1/EJ dx = [1/3 x^3/b^2]_0^b 1/EJ$$

$$= (1/3 b) 1/EJ = 1/3 b/EJ$$

$$L_{ED}^{xx} = \int_0^b (1 - 2x/b + x^2/b^2) 1/EJ dx = [x - x^2/b + 1/3 x^3/b^2]_0^b 1/EJ$$

$$= (b - b + 1/3 b) 1/EJ = 1/3 b/EJ$$

$$L_{EF}^{xx} = \int_0^b (1) 1/EJ dx = [x]_0^b 1/EJ$$

$$= (b) 1/EJ = b/EJ$$

$$L_{FE}^{xx} = \int_0^b (1) 1/EJ dx = [x]_0^b 1/EJ$$

$$= (b) 1/EJ = b/EJ$$

$$L_{FC}^{xx} = \int_0^b (1 - 2x/b + x^2/b^2) 1/EJ dx = [x - x^2/b + 1/3 x^3/b^2]_0^b 1/EJ$$

$$= (b - b + 1/3 b) 1/EJ = 1/3 b/EJ$$

$$L_{CF}^{xx} = \int_0^b (x^2/b^2) 1/EJ dx = [1/3 x^3/b^2]_0^b 1/EJ$$

$$= (1/3 b) 1/EJ = 1/3 b/EJ$$

$$L_{EF}^{xo} = \int_0^b (-1/2 x/b) Fb 1/EJ dx + \int_0^b (1) \theta dx = [-1/4 x^2/b]_0^b Fb 1/EJ + [x]_0^b \theta$$

$$= (-1/4 b) Fb 1/EJ + (b) \theta = 3/4 Fb^2/EJ$$

$$L_{FE}^{xo} = \int_0^b (-1/2 + 1/2 x/b) Fb 1/EJ dx + \int_0^b (-1) \theta dx = [-1/2 x + 1/4 x^2/b]_0^b Fb 1/EJ + [-x]_0^b \theta$$

$$= (-1/2 b + 1/4 b) Fb 1/EJ + (-b) \theta = 3/4 Fb^2/EJ$$

$$L_{FC}^{xo} = \int_0^b (-1/2 + 1/2 x/b + 1/2 x^2/b^2 - 1/2 x^3/b^3) Fb 1/EJ dx$$

$$= [-1/2 x + 1/4 x^2/b + 1/6 x^3/b^2 - 1/8 x^4/b^3]_0^b Fb 1/EJ$$

$$= (-1/2 b + 1/4 b + 1/6 b - 1/8 b) Fb 1/EJ = -5/24 Fb^2/EJ$$

$$L_{CF}^{xo} = \int_0^b (-x^2/b^2 + 1/2 x^3/b^3) Fb 1/EJ dx = [-1/3 x^3/b^2 + 1/8 x^4/b^3]_0^b Fb 1/EJ$$

$$= (-1/3 b + 1/8 b) Fb 1/EJ = -5/24 Fb^2/EJ$$

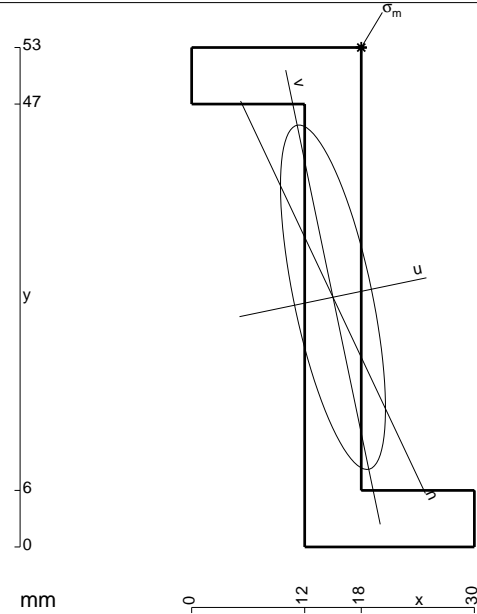

$A = 462. \text{ mm}^2$
 $J_x = 154395. \text{ mm}^4$
 $J_y = 14346. \text{ mm}^4$
 $J_{xy} = -30456. \text{ mm}^4$
 $J_u = 160731. \text{ mm}^4$
 $J_v = 8010. \text{ mm}^4$
 $\alpha = \text{artg}(2J_{xy}/(J_y - J_x))/2 = .2051$
 $c = \cos \alpha = .9790$
 $s = \sin \alpha = .2037$
 $x_g = 15. \text{ mm}$
 $y_g = 26.5 \text{ mm}$
 $N = -822.9 \text{ N}$
 $T_y = -411.4 \text{ N}$
 $M_x = 644000. \text{ Nmm}$
 $x_m = 18. \text{ mm}$
 $y_m = 53. \text{ mm}$
 $u_m = 8.335 \text{ mm}$
 $v_m = 25.33 \text{ mm}$
 $\sigma_m = N/A - Mcv/J_u - Msu/J_v = -237.7 \text{ N/mm}^2$

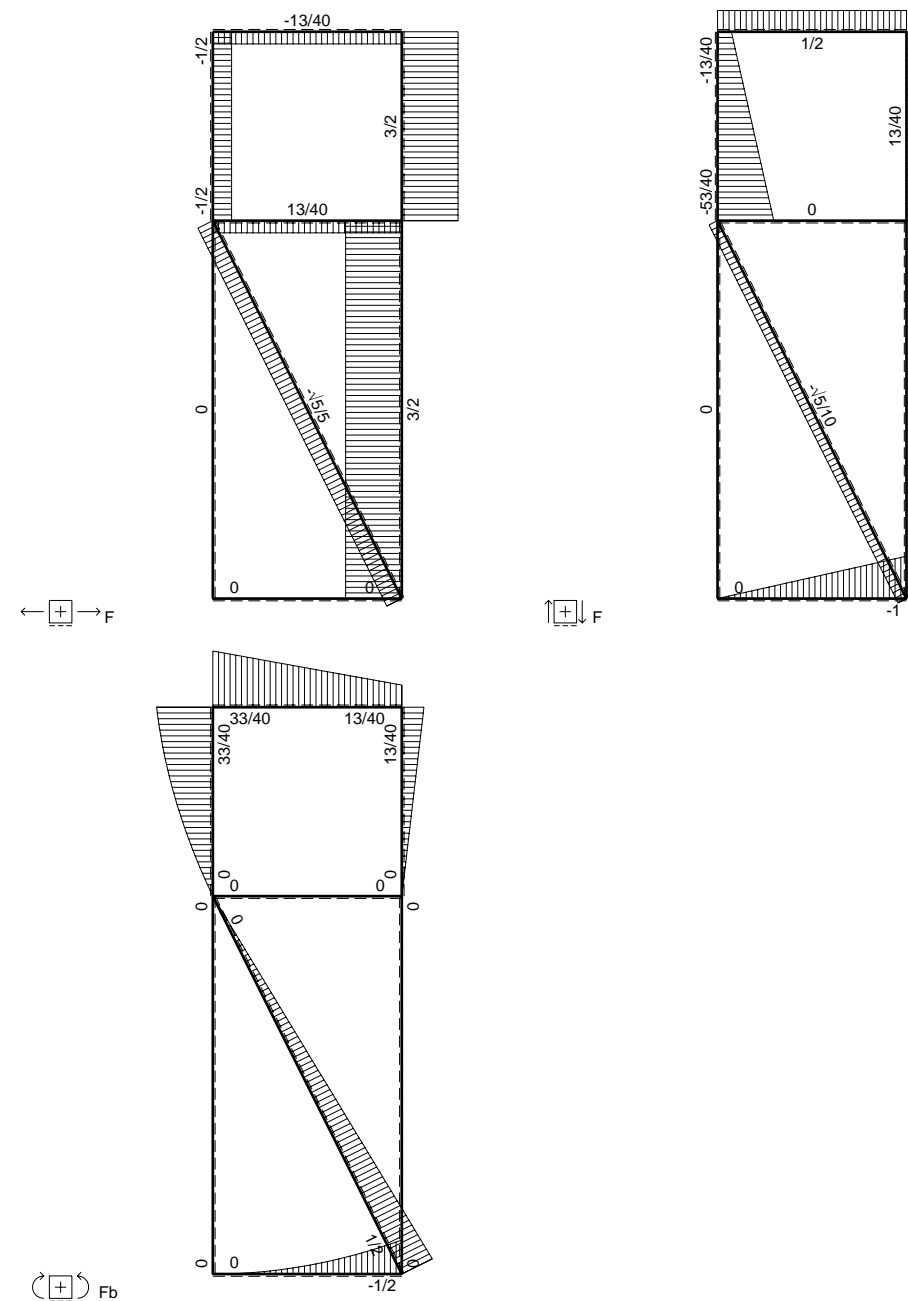
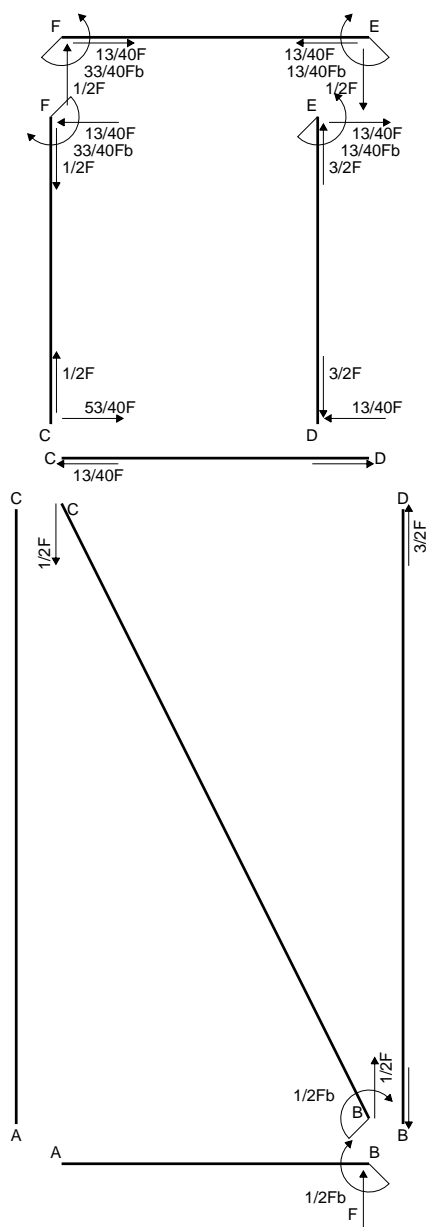

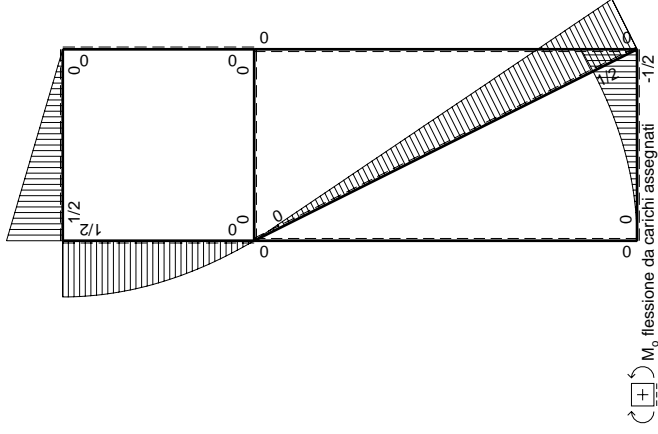
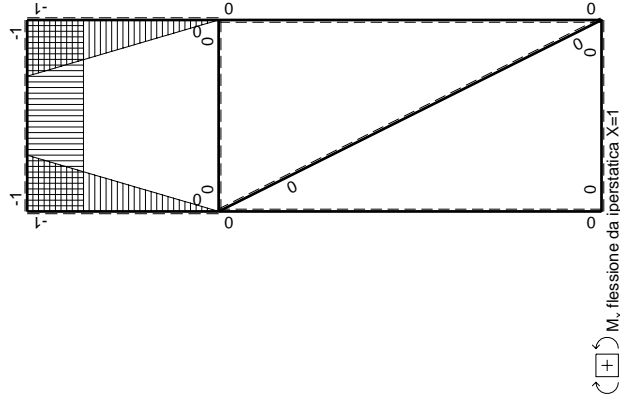
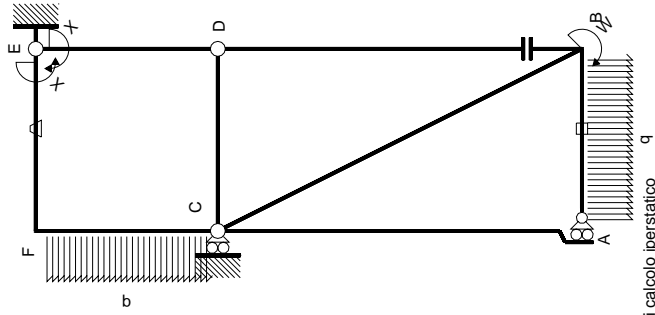

Quadro contributi PLV per iperstatica $X=W_{EF}$		$M_x(x)$		$M_0(x)$		$M_x \theta$	$M_x M_x$	$\int M_x(M_0/EJ+\theta)dx$	$\int M_x M_x/EJ dx$
AB b	0	$-1/2qx^2$	0	0	0	0	0	0+0	0
BA b	0	$1/2Fb-Fx+1/2qx^2$	0	0	0	0	0	0	0
BC $\sqrt{5}b$	0	$1/2Fb-\sqrt{5}/10Fx$	0	0	0	0	0	0	0
AC 2b	0	0	0	0	0	0	0	0+0	0
CA 2b	0	0	0	0	0	0	0	0	0
DB 2b	0	0	0	0	0	0	0	0+0	0
BD 2b	0	0	0	0	0	0	0	0	0
DE b	-x/b	0	0	0	0	0	x^2/b^2	0+0	1/3Xb/EJ
ED b	1-x/b	0	0	0	0	0	$1-2x/b+x^2/b^2$	0+0	1/3Xb/EJ
CD b	0	0	0	0	0	0	0	0+0	0
DC b	0	0	0	0	0	0	0	0+0	0
EF b	-1	$1/2Fx$	-Fb/EJ	$-1/2Fx$	Fb/EJ	Fb/EJ	1	$(-1/4+1)Fb^2/EJ$	Xb/EJ
FE b	1	$-1/2Fb+1/2Fx$	Fb/EJ	$-1/2Fb+1/2Fx$	Fb/EJ	Fb/EJ	1	$(-1/4+1)Fb^2/EJ$	Xb/EJ
FC b	-1+x/b	$1/2Fb-1/2qx^2$	0	$-1/2Fb+1/2Fx+1/2Fx^2/b-1/2qx^3/b$	0	0	$1-2x/b+x^2/b^2$	$(-5/24+0)Fb^2/EJ$	1/3Xb/EJ
CF b	x/b	$-Fx+1/2qx^2$	0	$-Fx^2/b+1/2qx^3/b$	0	0	x^2/b^2	$13/24Fb^2/EJ$	5/3Xb/EJ
totali								$-13/40Fb$	

Sviluppi di calcolo iperstatica

$$L_{DE}^{xx} = \int_0^b (x^2/b^2) 1/EJ dx = [1/3 x^3/b^2]_0^b 1/EJ$$

$$= (1/3 b) 1/EJ = 1/3 b/EJ$$

$$L_{ED}^{xx} = \int_0^b (1 - 2x/b + x^2/b^2) 1/EJ dx = [x - x^2/b + 1/3 x^3/b^2]_0^b 1/EJ$$

$$= (b - b + 1/3 b) 1/EJ = 1/3 b/EJ$$

$$L_{EF}^{xx} = \int_0^b (1) 1/EJ dx = [x]_0^b 1/EJ$$

$$= (b) 1/EJ = b/EJ$$

$$L_{FE}^{xx} = \int_0^b (1) 1/EJ dx = [x]_0^b 1/EJ$$

$$= (b) 1/EJ = b/EJ$$

$$L_{FC}^{xx} = \int_0^b (1 - 2x/b + x^2/b^2) 1/EJ dx = [x - x^2/b + 1/3 x^3/b^2]_0^b 1/EJ$$

$$= (b - b + 1/3 b) 1/EJ = 1/3 b/EJ$$

$$L_{CF}^{xx} = \int_0^b (x^2/b^2) 1/EJ dx = [1/3 x^3/b^2]_0^b 1/EJ$$

$$= (1/3 b) 1/EJ = 1/3 b/EJ$$

$$L_{EF}^{xo} = \int_0^b (-1/2 x/b) Fb 1/EJ dx + \int_0^b (1) \theta dx = [-1/4 x^2/b]_0^b Fb 1/EJ + [x]_0^b \theta$$

$$= (-1/4 b) Fb 1/EJ + (b) \theta = 3/4 Fb^2/EJ$$

$$L_{FE}^{xo} = \int_0^b (-1/2 + 1/2 x/b) Fb 1/EJ dx + \int_0^b (-1) \theta dx = [-1/2 x + 1/4 x^2/b]_0^b Fb 1/EJ + [-x]_0^b \theta$$

$$= (-1/2 b + 1/4 b) Fb 1/EJ + (-b) \theta = 3/4 Fb^2/EJ$$

$$L_{FC}^{xo} = \int_0^b (-1/2 + 1/2 x/b + 1/2 x^2/b^2 - 1/2 x^3/b^3) Fb 1/EJ dx$$

$$= [-1/2 x + 1/4 x^2/b + 1/6 x^3/b^2 - 1/8 x^4/b^3]_0^b Fb 1/EJ$$

$$= (-1/2 b + 1/4 b + 1/6 b - 1/8 b) Fb 1/EJ = -5/24 Fb^2/EJ$$

$$L_{CF}^{xo} = \int_0^b (-x^2/b^2 + 1/2 x^3/b^3) Fb 1/EJ dx = [-1/3 x^3/b^2 + 1/8 x^4/b^3]_0^b Fb 1/EJ$$

$$= (-1/3 b + 1/8 b) Fb 1/EJ = -5/24 Fb^2/EJ$$

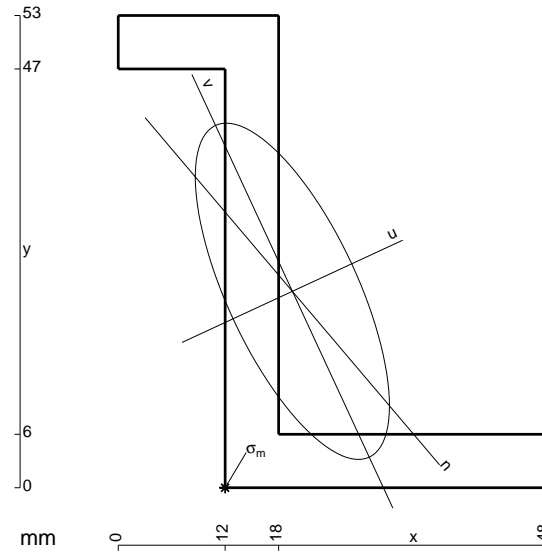

$A = 570. \text{ mm}^2$
 $J_x = 203061. \text{ mm}^4$
 $J_y = 67683. \text{ mm}^4$
 $J_{xy} = -79827. \text{ mm}^4$
 $J_u = 240034. \text{ mm}^4$
 $J_v = 30710. \text{ mm}^4$
 $\alpha = \text{artg}(2J_{xy}/(J_y - J_x))/2 = .4337$
 $c = \cos \alpha = .9074$
 $s = \sin \alpha = .4203$
 $x_g = 19.55 \text{ mm}$
 $y_g = 22.05 \text{ mm}$
 $N = -754. \text{ N}$
 $T_y = 1160. \text{ N}$
 $M_x = 708180. \text{ Nm}$
 $x_m = 12. \text{ mm}$
 $u_m = -16.11 \text{ mm}$
 $v_m = -16.83 \text{ mm}$
 $\sigma_m = N/A - Mcv/J_u - Msu/J_v = 199.9 \text{ N/mm}^2$

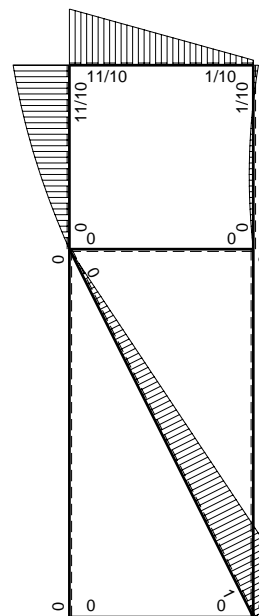
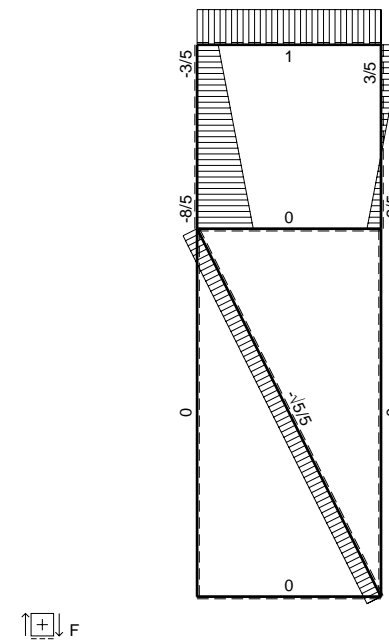
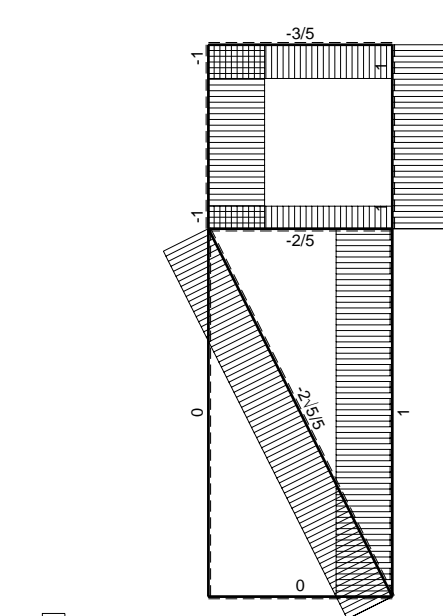
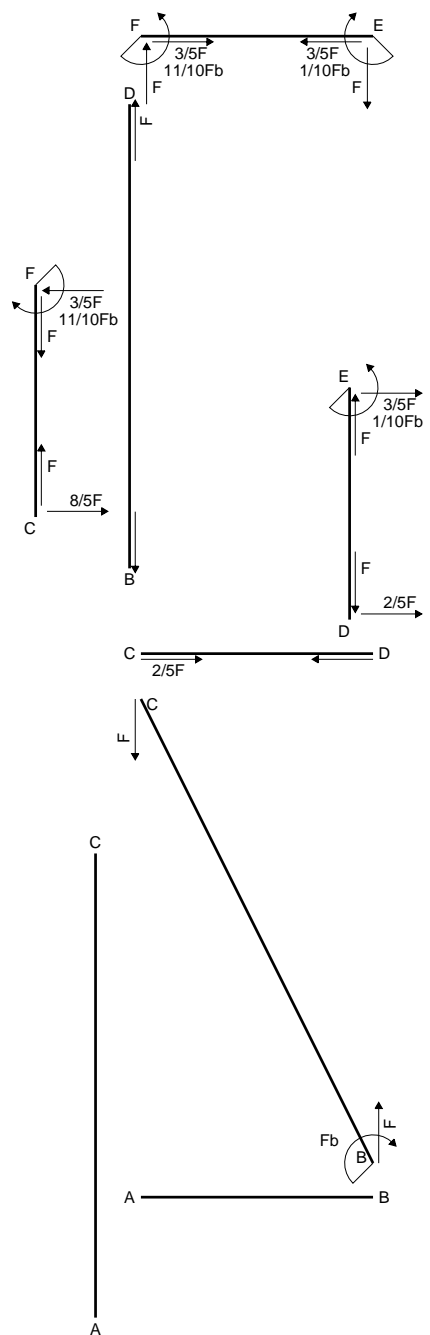

$\curvearrowright \oplus \curvearrowleft F_b$

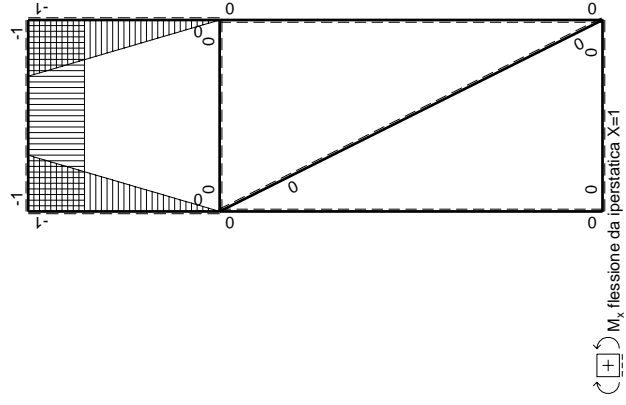
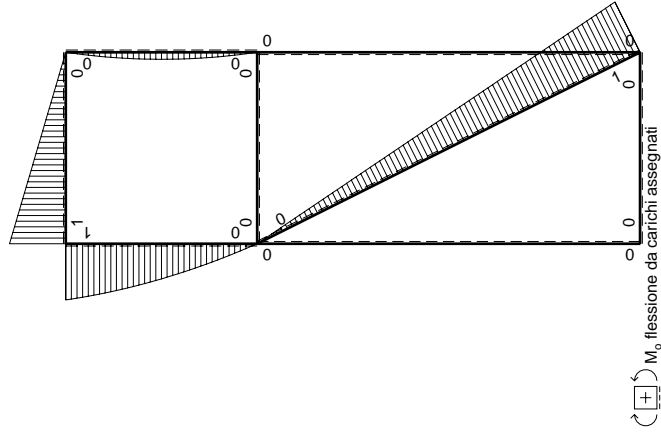
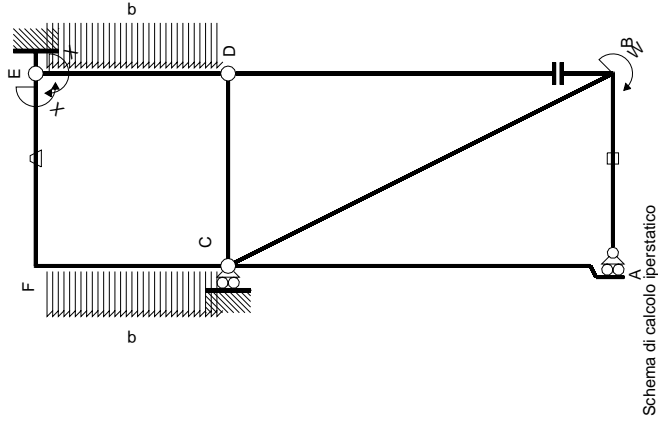

Quadro contributi PLV per iperstatica $X=W_{EF}$

\rightarrow	$M(x)$	$M_0(x)$	θ	$M_x M_0$	$M_x \theta$	$M_x M_x$	$\int M_x(M_0/EJ+\theta)dx$	$\int M_x M_x/EJ dx$
AB b	0	0	0	0	0	0	0+0	0
BA b	0	0	0	0	0	0	0	0
BC $\sqrt{5}b$	0	$Fb-\sqrt{5}/5Fx$	0	0	0	0	0+0	0
CA 2b	0	0	0	0	0	0	0+0	0
DB 2b	0	0	0	0	0	0	0+0	0
BD 2b	0	0	0	0	0	0	0+0	0
DE b	$-x/b$	$-1/2Fx+1/2qx^2$	0	$1/2Fx^2/b-1/2qx^3/b$	0	0	x^2/b^2	0
ED b	$1-x/b$	$1/2Fx-1/2qx^2$	0	$1/2Fx-Fx^2/b+1/2qx^3/b$	0	0	$1-2x/b+x^2/b^2$	$1/3xb/EJ$
CD b	0	0	0	0	0	0	0+0	0
FE b	-1	Fx	$-Fb/EJ$	-Fx	Fb/EJ	1	$(-1/2+1)Fb^2/EJ$	xb/EJ
FE b	1	$-Fb+Fx$	Fb/EJ	$-Fb+Fx$	Fb/EJ	1	$(-1/2+1)Fb^2/EJ$	xb/EJ
FC b	$-1+x/b$	$Fb-1/2Fx-1/2qx^2$	0	$-Fb+3/2Fx-1/2qx^3/b$	0	0	$1-2x/b+x^2/b^2$	$1/3xb/EJ$
CF b	x/b	$-3/2Fx+1/2qx^2$	0	$-3/2Fx^2/b+1/2qx^3/b$	0	0	x^2/b^2	$1/3xb/EJ$
totali								$5/3xb/EJ$
iperstatica $X=W_{EF}$								$-1/10Fb$

Sviluppi di calcolo iperstatica

$$L_{DE}^{xx} = \int_0^b (x^2/b^2) 1/EJ dx = [1/3 x^3/b^2]_0^b 1/EJ$$

$$= (1/3 b) 1/EJ = 1/3 b/EJ$$

$$L_{ED}^{xx} = \int_0^b (1 - 2x/b + x^2/b^2) 1/EJ dx = [x - x^2/b + 1/3 x^3/b^2]_0^b 1/EJ$$

$$= (b - b + 1/3 b) 1/EJ = 1/3 b/EJ$$

$$L_{EF}^{xx} = \int_0^b (1) 1/EJ dx = [x]_0^b 1/EJ$$

$$= (b) 1/EJ = b/EJ$$

$$L_{FE}^{xx} = \int_0^b (1) 1/EJ dx = [x]_0^b 1/EJ$$

$$= (b) 1/EJ = b/EJ$$

$$L_{FC}^{xx} = \int_0^b (1 - 2x/b + x^2/b^2) 1/EJ dx = [x - x^2/b + 1/3 x^3/b^2]_0^b 1/EJ$$

$$= (b - b + 1/3 b) 1/EJ = 1/3 b/EJ$$

$$L_{CF}^{xx} = \int_0^b (x^2/b^2) 1/EJ dx = [1/3 x^3/b^2]_0^b 1/EJ$$

$$= (1/3 b) 1/EJ = 1/3 b/EJ$$

$$L_{DE}^{xo} = \int_0^b (1/2 x^2/b^2 - 1/2 x^3/b^3) Fb 1/EJ dx = [1/6 x^3/b^2 - 1/8 x^4/b^3]_0^b Fb 1/EJ$$

$$= (1/6 b - 1/8 b) Fb 1/EJ = 1/24 Fb^2/EJ$$

$$L_{ED}^{xo} = \int_0^b (1/2 x/b - x^2/b^2 + 1/2 x^3/b^3) Fb 1/EJ dx = [1/4 x^2/b - 1/3 x^3/b^2 + 1/8 x^4/b^3]_0^b Fb 1/EJ$$

$$= (1/4 b - 1/3 b + 1/8 b) Fb 1/EJ = 1/24 Fb^2/EJ$$

$$L_{EF}^{xo} = \int_0^b (-x/b) Fb 1/EJ dx + \int_0^b (1) \theta dx = [-1/2 x^2/b]_0^b Fb 1/EJ + [x]_0^b \theta$$

$$= (-1/2 b) Fb 1/EJ + (b) \theta = 1/2 Fb^2/EJ$$

$$L_{FE}^{xo} = \int_0^b (-1 + x/b) Fb 1/EJ dx + \int_0^b (-1) \theta dx = [-x + 1/2 x^2/b]_0^b Fb 1/EJ + [-x]_0^b \theta$$

$$= (-b + 1/2 b) Fb 1/EJ + (-b) \theta = 1/2 Fb^2/EJ$$

$$L_{FC}^{xo} = \int_0^b (-1 + 3/2 x/b - 1/2 x^3/b^3) Fb 1/EJ dx = [-x + 3/4 x^2/b - 1/8 x^4/b^3]_0^b Fb 1/EJ$$

$$= (-b + 3/4 b - 1/8 b) Fb 1/EJ = -3/8 Fb^2/EJ$$

$$L_{CF}^{xo} = \int_0^b (-3/2 x^2/b^2 + 1/2 x^3/b^3) Fb 1/EJ dx = [-1/2 x^3/b^2 + 1/8 x^4/b^3]_0^b Fb 1/EJ$$

$$= (-1/2 b + 1/8 b) Fb 1/EJ = -3/8 Fb^2/EJ$$

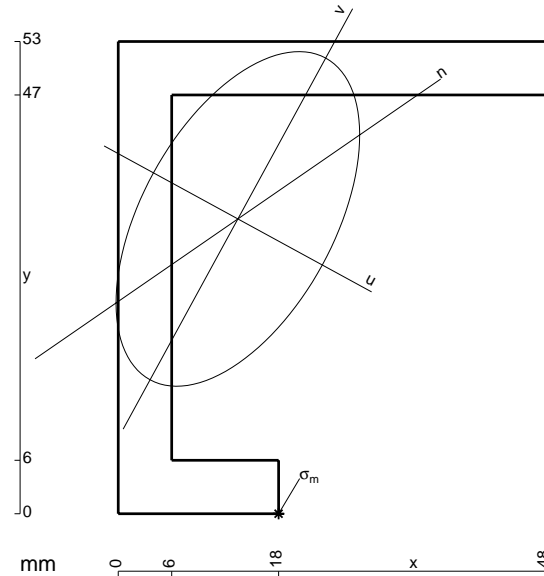

- A = 642. mm²
- J_x = 226469. mm⁴
- J_y = 120007. mm⁴
- J_{xy} = 82782. mm⁴
- J_u = 271657. mm⁴
- J_v = 74819. mm⁴
- α = arctg(2J_{xy}/(J_y-J_x))/2 = -.4997
- c = cos α = .8777
- s = sin α = -.4791
- x_g = 13.43 mm
- y_g = 33.09 mm
- N = -1350. N
- T_y = 2250. N
- M_x = 990000. Nmm
- x_m = 18. mm
- u_m = 19.87 mm
- v_m = -26.85 mm
- σ_m = N/A - Mcv/J_u - Msu/J_v = 209.7 N/mm²

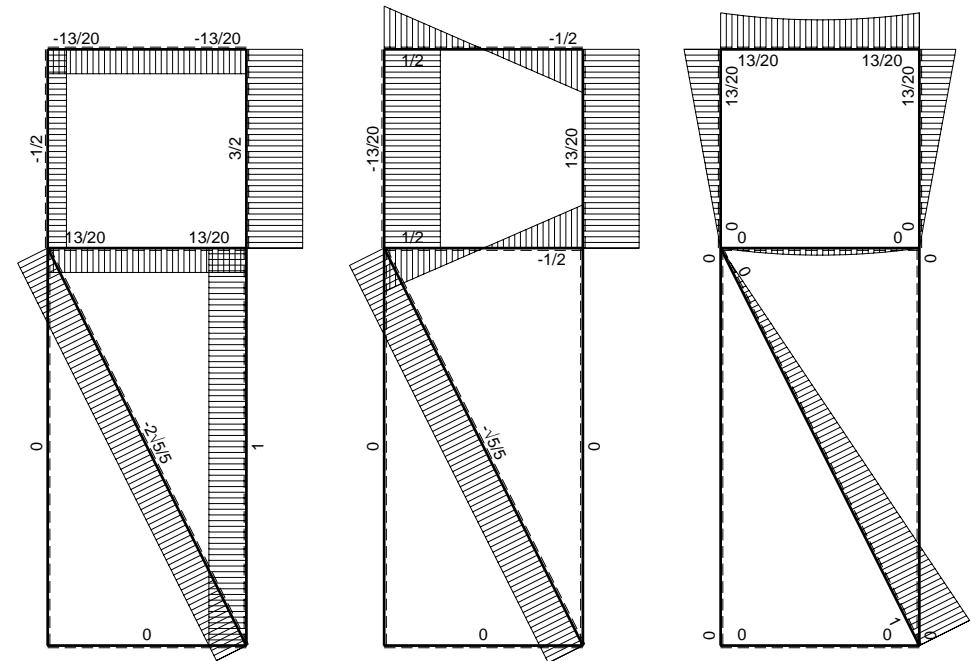
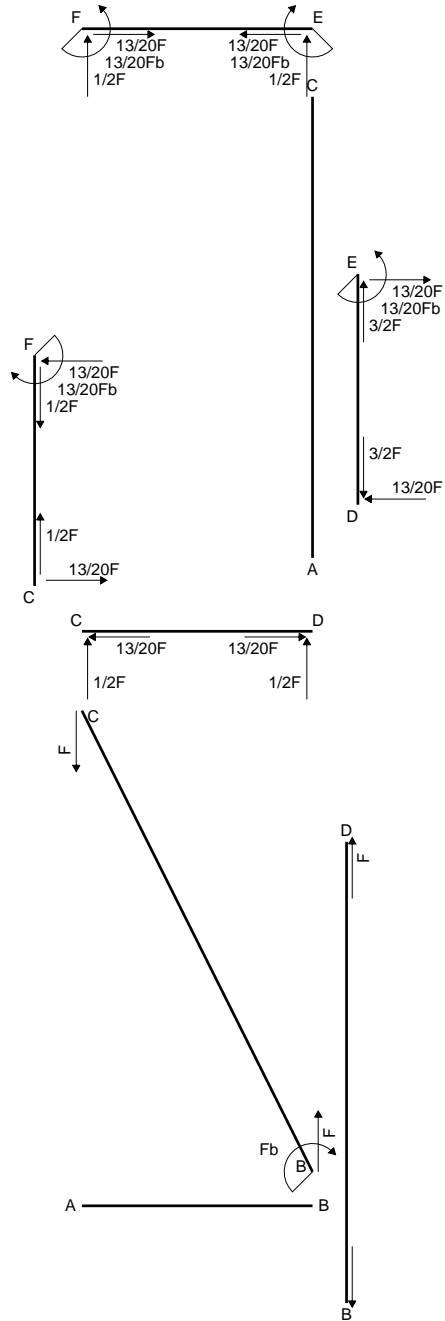

← ⊕ → F

↑ ⊕ ↓ F

⊕ ⊖ F_b

$$L_{DE}^{xx} = \int_0^b (x^2/b^2) 1/EJ dx = [1/3 x^3/b^2]_0^b 1/EJ$$

$$= (1/3 b) 1/EJ = 1/3 b/EJ$$

$$L_{ED}^{xx} = \int_0^b (1 - 2x/b + x^2/b^2) 1/EJ dx = [x - x^2/b + 1/3 x^3/b^2]_0^b 1/EJ$$

$$= (b - b + 1/3 b) 1/EJ = 1/3 b/EJ$$

$$L_{EF}^{xx} = \int_0^b (1) 1/EJ dx = [x]_0^b 1/EJ$$

$$= (b) 1/EJ = b/EJ$$

$$L_{FE}^{xx} = \int_0^b (1) 1/EJ dx = [x]_0^b 1/EJ$$

$$= (b) 1/EJ = b/EJ$$

$$L_{FC}^{xx} = \int_0^b (1 - 2x/b + x^2/b^2) 1/EJ dx = [x - x^2/b + 1/3 x^3/b^2]_0^b 1/EJ$$

$$= (b - b + 1/3 b) 1/EJ = 1/3 b/EJ$$

$$L_{CF}^{xx} = \int_0^b (x^2/b^2) 1/EJ dx = [1/3 x^3/b^2]_0^b 1/EJ$$

$$= (1/3 b) 1/EJ = 1/3 b/EJ$$

$$L_{EF}^{xo} = \int_0^b (1/2 x/b - 1/2 x^2/b^2) Fb 1/EJ dx + \int_0^b (1) \theta dx = [1/4 x^2/b - 1/6 x^3/b^2]_0^b Fb 1/EJ + [x]_0^b \theta$$

$$= (1/4 b - 1/6 b) Fb 1/EJ + (b) \theta = 13/12 Fb^2/EJ$$

$$L_{FE}^{xo} = \int_0^b (1/2 x/b - 1/2 x^2/b^2) Fb 1/EJ dx + \int_0^b (-1) \theta dx = [1/4 x^2/b - 1/6 x^3/b^2]_0^b Fb 1/EJ + [-x]_0^b \theta$$

$$= (1/4 b - 1/6 b) Fb 1/EJ + (-b) \theta = 13/12 Fb^2/EJ$$

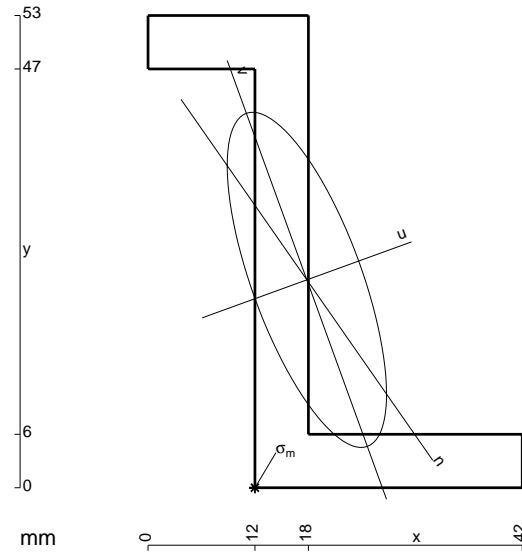

$A = 534. \text{ mm}^2$
 $J_x = 189011. \text{ mm}^4$
 $J_y = 42681. \text{ mm}^4$
 $J_{xy} = -61197. \text{ mm}^4$
 $J_u = 211231. \text{ mm}^4$
 $J_v = 20461. \text{ mm}^4$
 $\alpha = \text{artg}(2J_{xy}/(J_y - J_x))/2 = .3483$
 $c = \cos\alpha = .9400$
 $s = \sin\alpha = .3413$
 $x_g = 17.83 \text{ mm}$
 $y_g = 23.33 \text{ mm}$
 $N = -1440. \text{ N}$
 $T_y = -720. \text{ N}$
 $M_x = 708400. \text{ Nmm}$
 $x_m = 12. \text{ mm}$
 $u_m = -13.44 \text{ mm}$
 $v_m = -19.94 \text{ mm}$
 $\sigma_m = N/A - Mcv/J_u - Msu/J_v = 219. \text{ N/mm}^2$

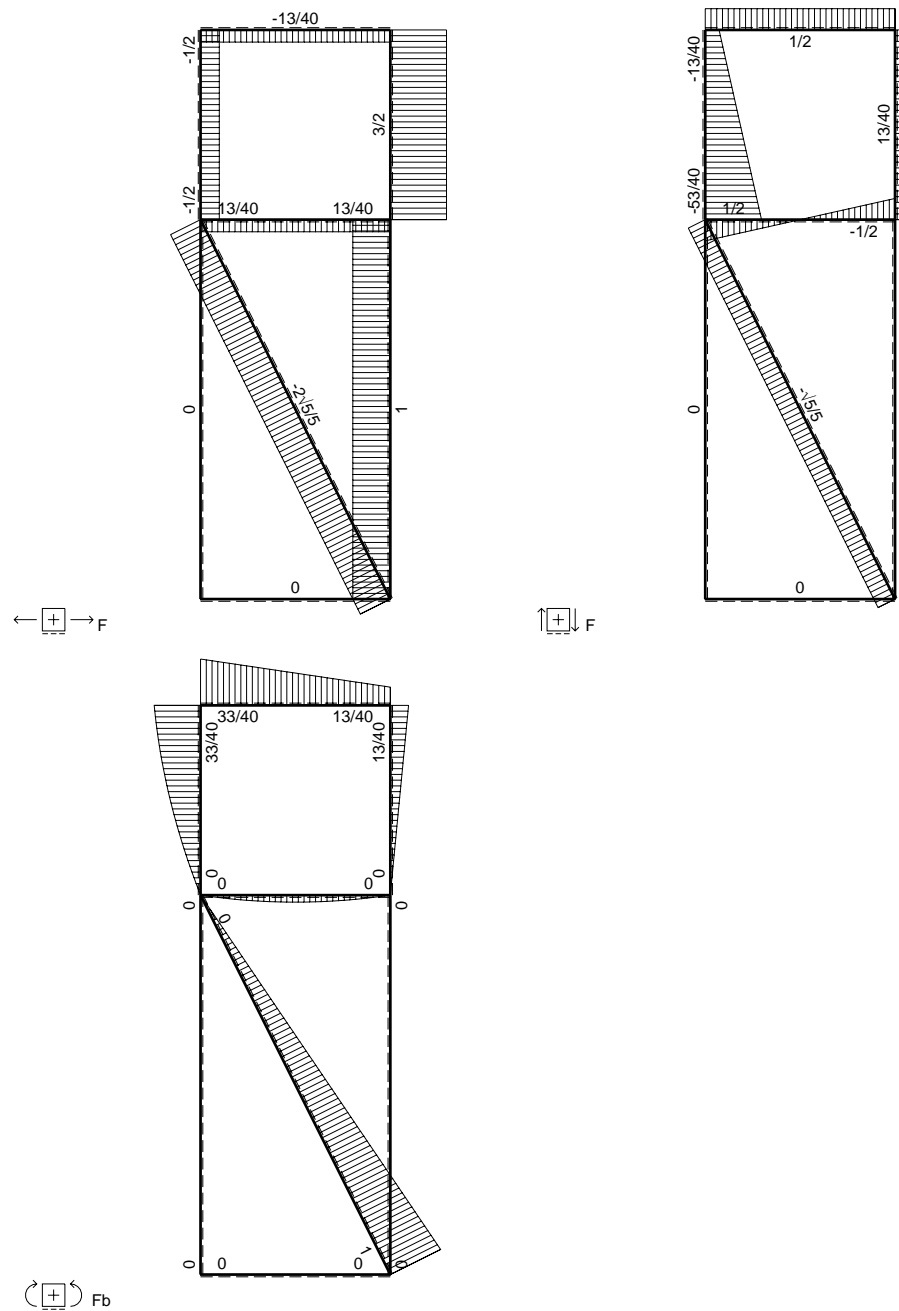
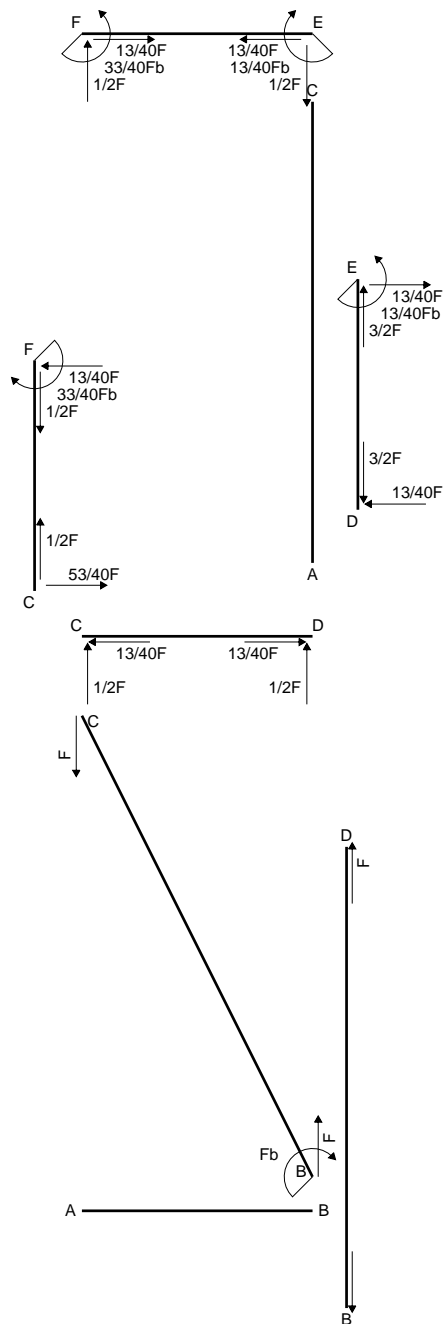

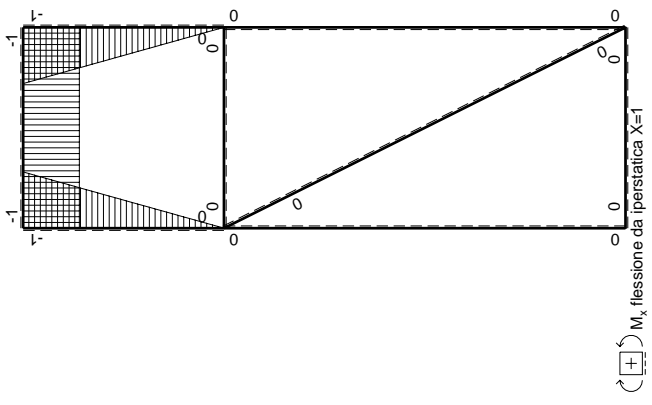
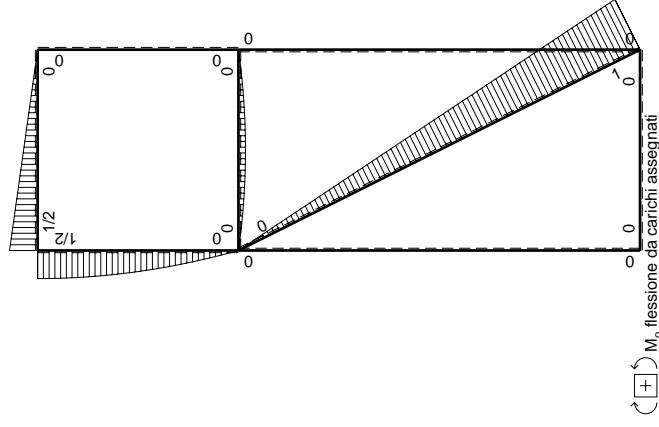
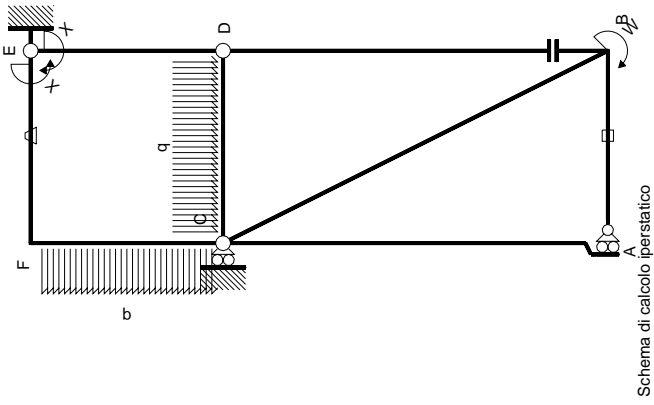

Quadro contributi PLV per iperstatica X=W^{EP}

←	$M(x)$	$M_0(x)$	θ	$M_x M_0$	$M_x \theta$	$M_x M_x$	$\int M_x(M_0/EJ+\theta)dx$	$\int M_x M_x/EJdx$
AB b	0	0	0	0	0	0	0+0	0
BA b	0	0	0	0	0	0	0	0
BC $\sqrt{5}b$	$Fb-\sqrt{5}Fx$	0	0	0	0	0	0+0	0
CA 2b	0	0	0	0	0	0	0+0	0
DB 2b	0	0	0	0	0	0	0+0	0
ED b	-x/b	0	0	0	0	0	0+0	1/3Xb/EJ
CD b	$1/2Fx-1/2qx^2$	0	0	0	0	0	0+0	0
DC b	$-1/2Fx+1/2qx^2$	0	0	0	0	0	0+0	0
EF b	-1	$1/2Fx$	-Fb/EJ	$-1/2Fx$	Fb/EJ	1	$(-1/4+1)Fb^2/EJ$	Xb/EJ
FE b	1	$-1/2Fb+1/2Fx$	Fb/EJ	$-1/2Fb+1/2Fx$	Fb/EJ	1	$(-1/4+1)Fb^2/EJ$	Xb/EJ
FC b	$-1+x/b$	$1/2Fb-1/2qx^2$	0	$-1/2Fb+1/2Fx+1/2Fx^2/b-1/2qx^3/b$	0	$1-2x/b+x^2/b^2$	$(-5/24+0)Fb^2/EJ$	1/3Xb/EJ
CF b	x/b	$-Fx+1/2qx^2$	0	$-Fx^2/b+1/2qx^3/b$	0	x^2/b^2	$(-5/24+0)Fb^2/EJ$	1/3Xb/EJ
totali								
							$13/24Fb^2/EJ$	$5/3Xb/EJ$
								$-13/40Fb$

Sviluppi di calcolo iperstatica

$$L_{DE}^{xx} = \int_0^b (x^2/b^2) 1/EJ dx = [1/3 x^3/b^2]_0^b 1/EJ$$

$$= (1/3 b) 1/EJ = 1/3 b/EJ$$

$$L_{ED}^{xx} = \int_0^b (1 - 2x/b + x^2/b^2) 1/EJ dx = [x - x^2/b + 1/3 x^3/b^2]_0^b 1/EJ$$

$$= (b - b + 1/3 b) 1/EJ = 1/3 b/EJ$$

$$L_{EF}^{xx} = \int_0^b (1) 1/EJ dx = [x]_0^b 1/EJ$$

$$= (b) 1/EJ = b/EJ$$

$$L_{FE}^{xx} = \int_0^b (1) 1/EJ dx = [x]_0^b 1/EJ$$

$$= (b) 1/EJ = b/EJ$$

$$L_{FC}^{xx} = \int_0^b (1 - 2x/b + x^2/b^2) 1/EJ dx = [x - x^2/b + 1/3 x^3/b^2]_0^b 1/EJ$$

$$= (b - b + 1/3 b) 1/EJ = 1/3 b/EJ$$

$$L_{CF}^{xx} = \int_0^b (x^2/b^2) 1/EJ dx = [1/3 x^3/b^2]_0^b 1/EJ$$

$$= (1/3 b) 1/EJ = 1/3 b/EJ$$

$$L_{EF}^{xo} = \int_0^b (-1/2 x/b) Fb 1/EJ dx + \int_0^b (1) \theta dx = [-1/4 x^2/b]_0^b Fb 1/EJ + [x]_0^b \theta$$

$$= (-1/4 b) Fb 1/EJ + (b) \theta = 3/4 Fb^2/EJ$$

$$L_{FE}^{xo} = \int_0^b (-1/2 + 1/2 x/b) Fb 1/EJ dx + \int_0^b (-1) \theta dx = [-1/2 x + 1/4 x^2/b]_0^b Fb 1/EJ + [-x]_0^b \theta$$

$$= (-1/2 b + 1/4 b) Fb 1/EJ + (-b) \theta = 3/4 Fb^2/EJ$$

$$L_{FC}^{xo} = \int_0^b (-1/2 + 1/2 x/b + 1/2 x^2/b^2 - 1/2 x^3/b^3) Fb 1/EJ dx$$

$$= [-1/2 x + 1/4 x^2/b + 1/6 x^3/b^2 - 1/8 x^4/b^3]_0^b Fb 1/EJ$$

$$= (-1/2 b + 1/4 b + 1/6 b - 1/8 b) Fb 1/EJ = -5/24 Fb^2/EJ$$

$$L_{CF}^{xo} = \int_0^b (-x^2/b^2 + 1/2 x^3/b^3) Fb 1/EJ dx = [-1/3 x^3/b^2 + 1/8 x^4/b^3]_0^b Fb 1/EJ$$

$$= (-1/3 b + 1/8 b) Fb 1/EJ = -5/24 Fb^2/EJ$$

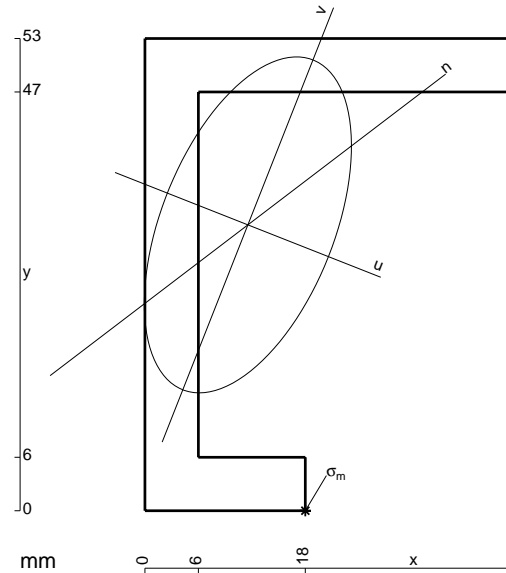

- A = 606. mm²
- J_x = 215454. mm⁴
- J_y = 81888. mm⁴
- J_{xy} = 62420. mm⁴
- J_u = 240083. mm⁴
- J_v = 57259. mm⁴
- α = arctg(2J_{xy}/(J_y-J_x))/2 = -.3758
- c = cos α = .9302
- s = sin α = -.3670
- x_g = 11.55 mm
- y_g = 32.08 mm
- N = -1968. N
- T_y = -983.9 N
- M_x = 1056000. Nmm
- x_m = 18. mm
- u_m = 17.77 mm
- v_m = -27.48 mm
- σ_m = N/A - Mcv/J_u - Msu/J_v = 229.5 N/mm²

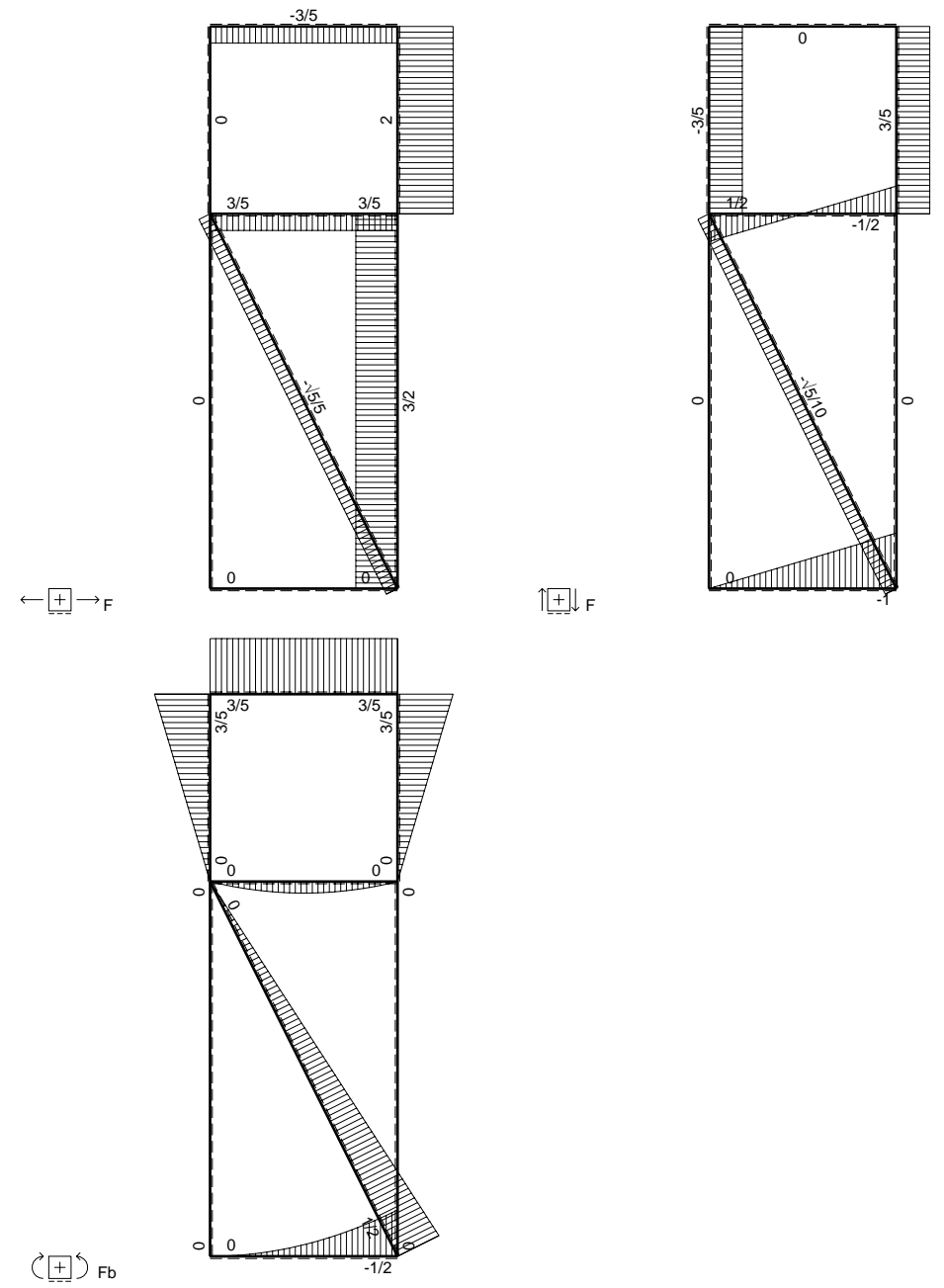
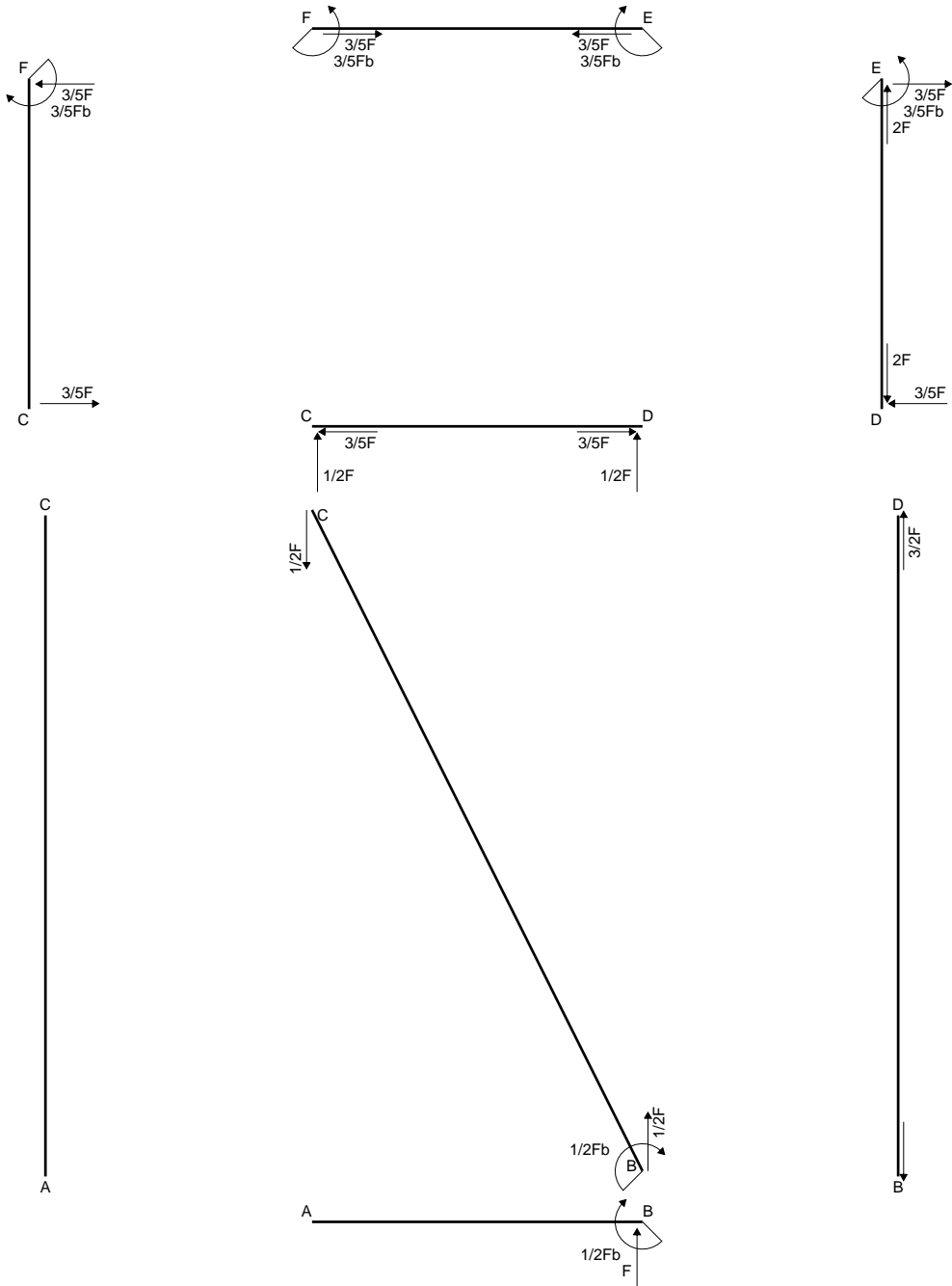

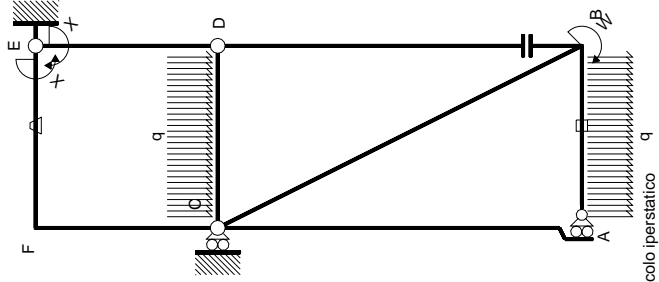

Schema di calcolo iperstatico

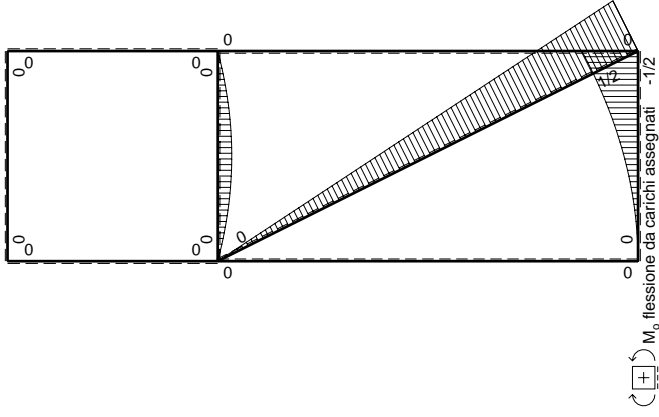

M_0 flessione da carichi assegnati -1/2

Quadro contributi PLV per iperstatica $X=W_{EF}$

\rightarrow	$M_x(x)$	$M_0(x)$	θ	$M_x M_0$	$M_x \theta$	$M_x M_x$	$\int M_x(M_0/EJ+\theta)dx$	$\int X M_x M_x / EJ dx$
AB b	0	$-1/2qx^2$	0	0	0	0	0+0	0
BA b	0	$1/2Fb-Fx+1/2qx^2$	0	0	0	0	0+0	0
BC $\sqrt{5}b$	0	$1/2Fb-\sqrt{5}/10Fx$	0	0	0	0	0	0
AC 2b	0	0	0	0	0	0	0+0	0
CA 2b	0	0	0	0	0	0	0+0	0
DB 2b	0	0	0	0	0	0	0+0	0
BD 2b	0	0	0	0	0	0	0+0	0
DE b	$-x/b$	0	0	0	0	x^2/b^2	0+0	$1/3Xb/EJ$
ED b	$1-x/b$	0	0	0	0	$1-2x/b+x^2/b^2$	0+0	$1/3Xb/EJ$
CD b	0	$1/2Fx-1/2qx^2$	0	0	0	0	0+0	0
DC b	0	$-1/2Fx+1/2qx^2$	0	0	0	0	0+0	0
EF b	-1	0	$-Fb/EJ$	0	Fb/EJ	1	$(0+1)Fb^2/EJ$	Xb/EJ
FE b	1	0	Fb/EJ	0	Fb/EJ	1		
FC b	$-1+x/b$	0	0	0	0	$1-2x/b+x^2/b^2$	0+0	$1/3Xb/EJ$
CF b	x/b	0	0	0	0	x^2/b^2	Fb^2/EJ	$5/3Xb/EJ$
	totali							
	iperstatica $X=W_{EF}$							

Sviluppi di calcolo iperstatica

M_x flessione da iperstatica $X=1$

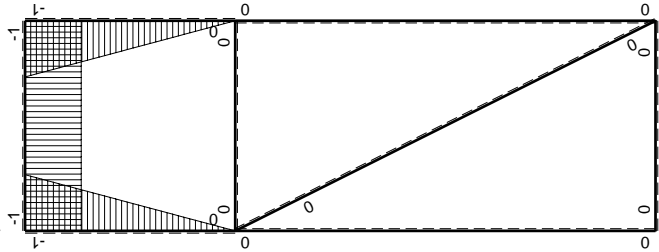

$$L_{DE}^{xx} = \int_0^b (x^2/b^2) 1/EJ dx = [1/3 x^3/b^2]_0^b 1/EJ$$

$$= (1/3 b) 1/EJ = 1/3 b/EJ$$

$$L_{ED}^{xx} = \int_0^b (1 - 2x/b + x^2/b^2) 1/EJ dx = [x - x^2/b + 1/3 x^3/b^2]_0^b 1/EJ$$

$$= (b - b + 1/3 b) 1/EJ = 1/3 b/EJ$$

$$L_{EF}^{xx} = \int_0^b (1) 1/EJ dx = [x]_0^b 1/EJ$$

$$= (b) 1/EJ = b/EJ$$

$$L_{FE}^{xx} = \int_0^b (1) 1/EJ dx = [x]_0^b 1/EJ$$

$$= (b) 1/EJ = b/EJ$$

$$L_{FC}^{xx} = \int_0^b (1 - 2x/b + x^2/b^2) 1/EJ dx = [x - x^2/b + 1/3 x^3/b^2]_0^b 1/EJ$$

$$= (b - b + 1/3 b) 1/EJ = 1/3 b/EJ$$

$$L_{CF}^{xx} = \int_0^b (x^2/b^2) 1/EJ dx = [1/3 x^3/b^2]_0^b 1/EJ$$

$$= (1/3 b) 1/EJ = 1/3 b/EJ$$

$$L_{EF}^{xo} = \int_0^b (1) \theta dx = [x]_0^b \theta$$

$$= (b) \theta = Fb^2/EJ$$

$$L_{FE}^{xo} = \int_0^b (-1) \theta dx = [-x]_0^b \theta$$

$$= (-b) \theta = Fb^2/EJ$$

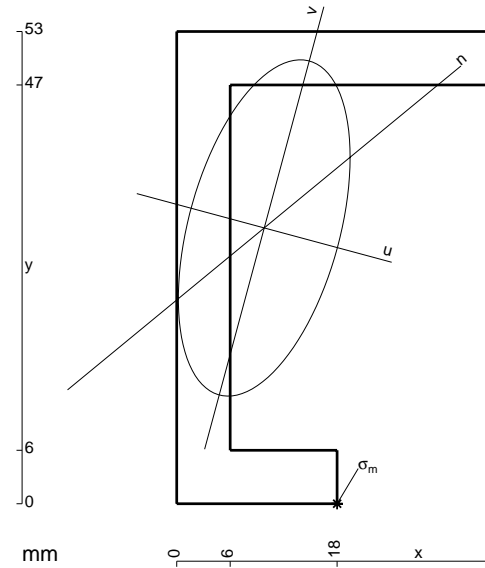

$A = 570. \text{ mm}^2$
 $J_x = 203061. \text{ mm}^4$
 $J_y = 52950. \text{ mm}^4$
 $J_{xy} = 43600. \text{ mm}^4$
 $J_u = 214806. \text{ mm}^4$
 $J_v = 41205. \text{ mm}^4$
 $\alpha = \text{artg}(2J_{xy}/(J_y - J_x))/2 = -.2631$
 $c = \cos \alpha = .9656$
 $s = \sin \alpha = -.2601$
 $x_g = 9.821 \text{ mm}$
 $y_g = 30.95 \text{ mm}$
 $N = 6620. \text{ N}$
 $T_y = 1986. \text{ N}$
 $M_x = 1012860. \text{ Nmm}$
 $x_m = 18. \text{ mm}$
 $u_m = 15.95 \text{ mm}$
 $v_m = -27.76 \text{ mm}$
 $\sigma_m = N/A - Mcv/J_u - Msu/J_v = 240. \text{ N/mm}^2$

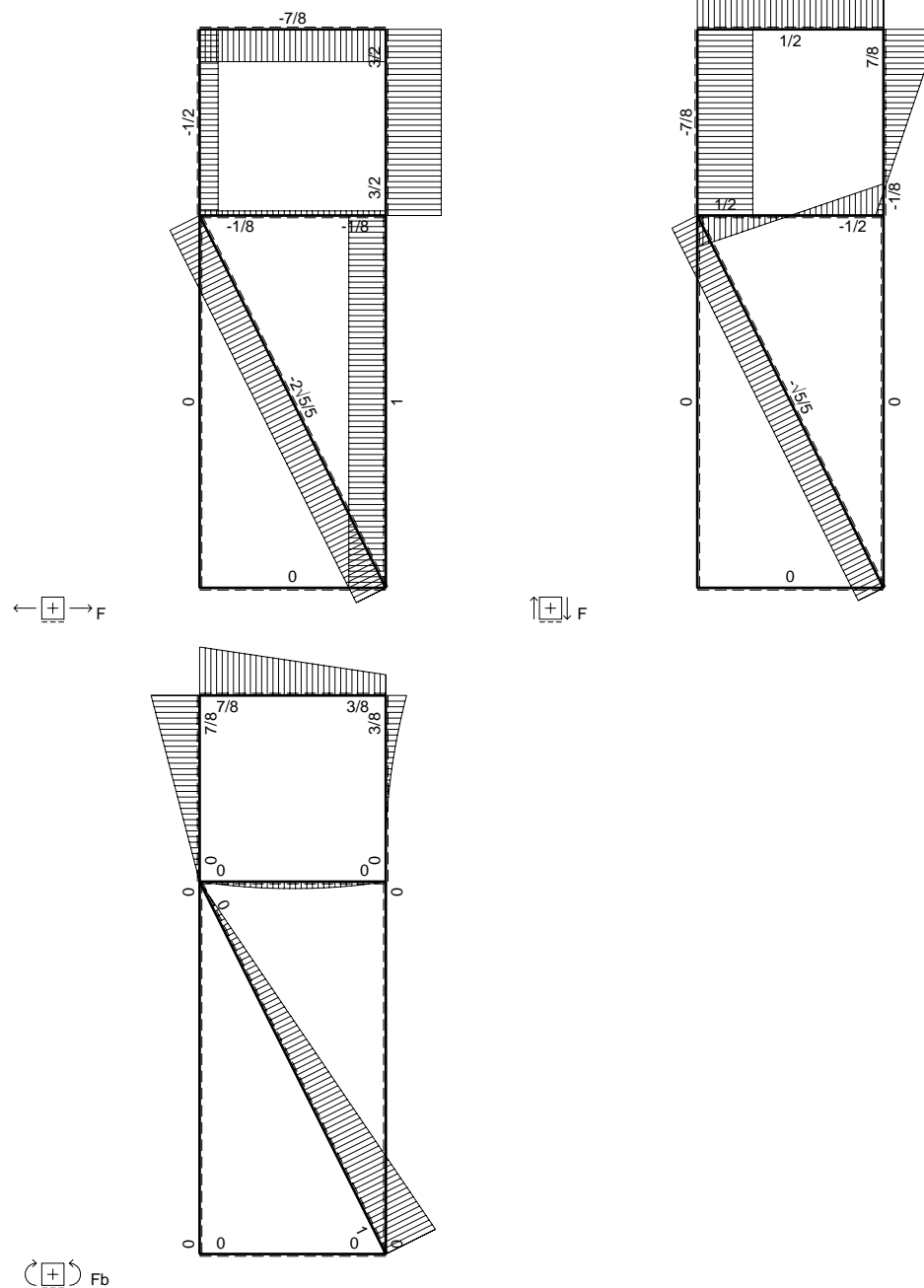
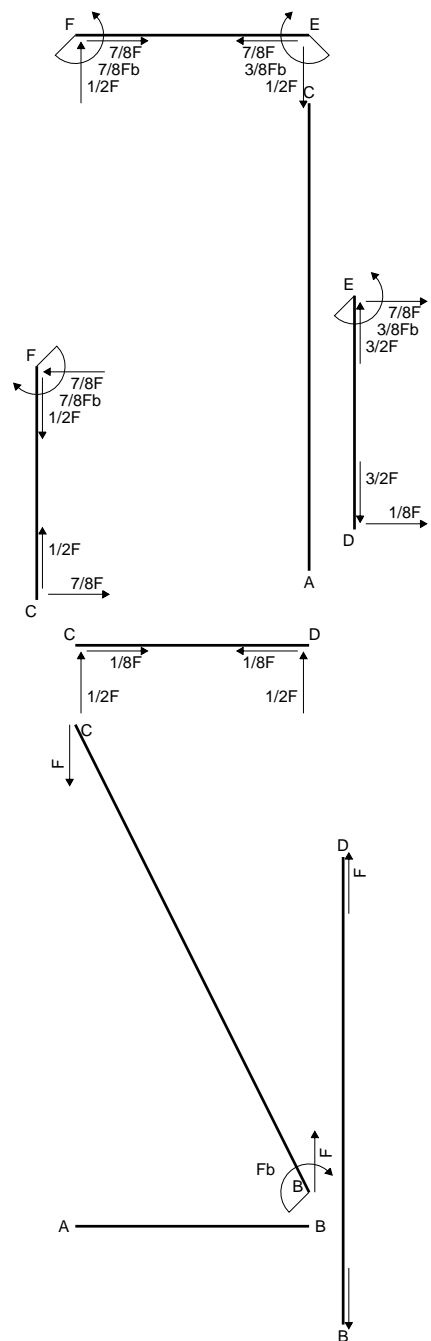

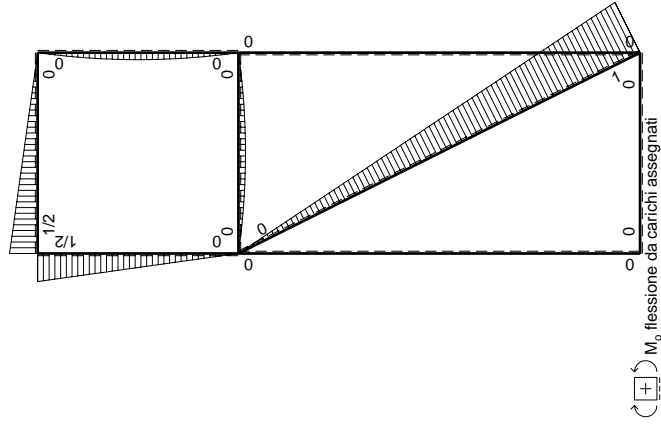
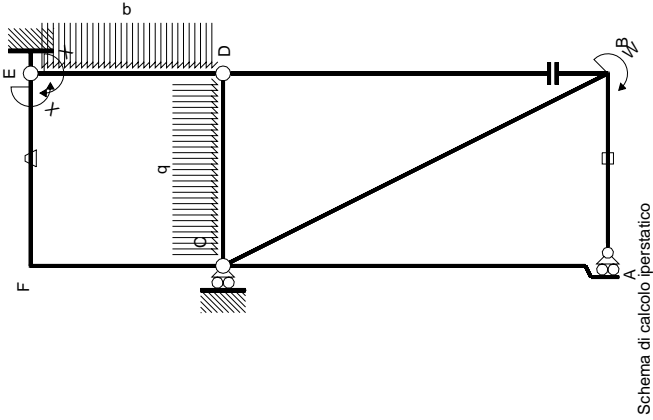

Quadro contributi PLV per iperstatica $X=W_{EF}$

←	$M^x(x)$	$M^0(x)$	θ	$M^x M_0$	$M^x \theta$	$M^x M_x$	$\int M^x (M_0/EJ + \theta) dx$	$\int M^x M_x / E dx$
AB b	0	0	0	0	0	0	0+0	0
BA b	0	0	0	0	0	0	0	0
BC $\sqrt{5}b$	0	$Fb\sqrt{5}/5Fx$	0	0	0	0	0+0	0
CA 2b	0	0	0	0	0	0	0+0	0
DB 2b	0	0	0	0	0	0	0+0	0
BD 2b	0	0	0	0	0	0	0+0	0
DE b	$-x/b$	$-1/2Fx + 1/2qx^2$	0	$1/2Fx^2/b - 1/2qx^3/b$	0	0	x^2/b^2	$1/3Xb/EJ$
ED b	$1-x/b$	$1/2Fx - 1/2qx^2$	0	$1/2Fx - Fx^2/b + 1/2qx^3/b$	0	0	$1-2x/b+x^2/b^2$	$1/3Xb/EJ$
CD b	0	$1/2Fx - 1/2qx^2$	0	0	0	0	0	0
DC b	0	$-1/2Fx + 1/2qx^2$	0	0	0	0	0+0	0
EF b	-1	$1/2Fx$	$-Fb/EJ$	$-1/2Fx$	Fb/EJ	1	$(-1/4+1)Fb^2/EJ$	Xb/EJ
FE b	1	$-1/2Fb + 1/2Fx$	Fb/EJ	$-1/2Fb + 1/2Fx$	Fb/EJ	1	$(-1/4+1)Fb^2/EJ$	Xb/EJ
FC b	$-1+x/b$	$1/2Fb - 1/2Fx$	0	$-1/2Fb + Fx - 1/2Fx^2/b$	0	0	$1-2x/b+x^2/b^2$	$1/3Xb/EJ$
CF b	x/b	$-1/2Fx$	0	$-1/2Fx^2/b$	0	0	x^2/b^2	$1/3Xb/EJ$
totali								$5/8Fb^2/EJ$
								$-3/8Fb$

Sviluppi di calcolo iperstatica

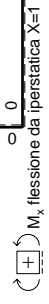

$$L_{DE}^{xx} = \int_0^b (x^2/b^2) 1/EJ dx = [1/3 x^3/b^2]_0^b 1/EJ$$

$$= (1/3 b) 1/EJ = 1/3 b/EJ$$

$$L_{ED}^{xx} = \int_0^b (1 - 2x/b + x^2/b^2) 1/EJ dx = [x - x^2/b + 1/3 x^3/b^2]_0^b 1/EJ$$

$$= (b - b + 1/3 b) 1/EJ = 1/3 b/EJ$$

$$L_{EF}^{xx} = \int_0^b (1) 1/EJ dx = [x]_0^b 1/EJ$$

$$= (b) 1/EJ = b/EJ$$

$$L_{FE}^{xx} = \int_0^b (1) 1/EJ dx = [x]_0^b 1/EJ$$

$$= (b) 1/EJ = b/EJ$$

$$L_{FC}^{xx} = \int_0^b (1 - 2x/b + x^2/b^2) 1/EJ dx = [x - x^2/b + 1/3 x^3/b^2]_0^b 1/EJ$$

$$= (b - b + 1/3 b) 1/EJ = 1/3 b/EJ$$

$$L_{CF}^{xx} = \int_0^b (x^2/b^2) 1/EJ dx = [1/3 x^3/b^2]_0^b 1/EJ$$

$$= (1/3 b) 1/EJ = 1/3 b/EJ$$

$$L_{DE}^{xo} = \int_0^b (1/2 x^2/b^2 - 1/2 x^3/b^3) Fb 1/EJ dx = [1/6 x^3/b^2 - 1/8 x^4/b^3]_0^b Fb 1/EJ$$

$$= (1/6 b - 1/8 b) Fb 1/EJ = 1/24 Fb^2/EJ$$

$$L_{ED}^{xo} = \int_0^b (1/2 x/b - x^2/b^2 + 1/2 x^3/b^3) Fb 1/EJ dx = [1/4 x^2/b - 1/3 x^3/b^2 + 1/8 x^4/b^3]_0^b Fb 1/EJ$$

$$= (1/4 b - 1/3 b + 1/8 b) Fb 1/EJ = 1/24 Fb^2/EJ$$

$$L_{EF}^{xo} = \int_0^b (-1/2 x/b) Fb 1/EJ dx + \int_0^b (1) \theta dx = [-1/4 x^2/b]_0^b Fb 1/EJ + [x]_0^b \theta$$

$$= (-1/4 b) Fb 1/EJ + (b) \theta = 3/4 Fb^2/EJ$$

$$L_{FE}^{xo} = \int_0^b (-1/2 + 1/2 x/b) Fb 1/EJ dx + \int_0^b (-1) \theta dx = [-1/2 x + 1/4 x^2/b]_0^b Fb 1/EJ + [-x]_0^b \theta$$

$$= (-1/2 b + 1/4 b) Fb 1/EJ + (-b) \theta = 3/4 Fb^2/EJ$$

$$L_{FC}^{xo} = \int_0^b (-1/2 + x/b - 1/2 x^2/b^2) Fb 1/EJ dx = [-1/2 x + 1/2 x^2/b - 1/6 x^3/b^2]_0^b Fb 1/EJ$$

$$= (-1/2 b + 1/2 b - 1/6 b) Fb 1/EJ = -1/6 Fb^2/EJ$$

$$L_{CF}^{xo} = \int_0^b (-1/2 x^2/b^2) Fb 1/EJ dx = [-1/6 x^3/b^2]_0^b Fb 1/EJ$$

$$= (-1/6 b) Fb 1/EJ = -1/6 Fb^2/EJ$$

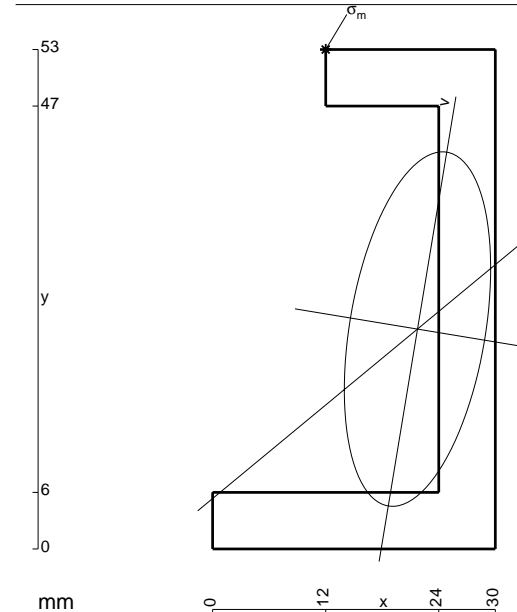

- A = 534. mm²
- J_x = 189011. mm⁴
- J_y = 32196. mm⁴
- J_{xy} = 26635. mm⁴
- J_u = 193412. mm⁴
- J_v = 27796. mm⁴
- α = arctg(2J_{xy}/(J_y-J_x))/2 = -.1637
- c = cos α = .9866
- s = sin α = -.1630
- x_g = 21.74 mm
- y_g = 23.33 mm
- N = -1413. N
- T_y = -706.6 N
- M_x = 869000. Nmm
- x_m = 12. mm
- y_m = 53. mm
- u_m = -14.45 mm
- v_m = 27.68 mm
- σ_m = N/A - Mcv/J_u - Msu/J_v = -199. N/mm²

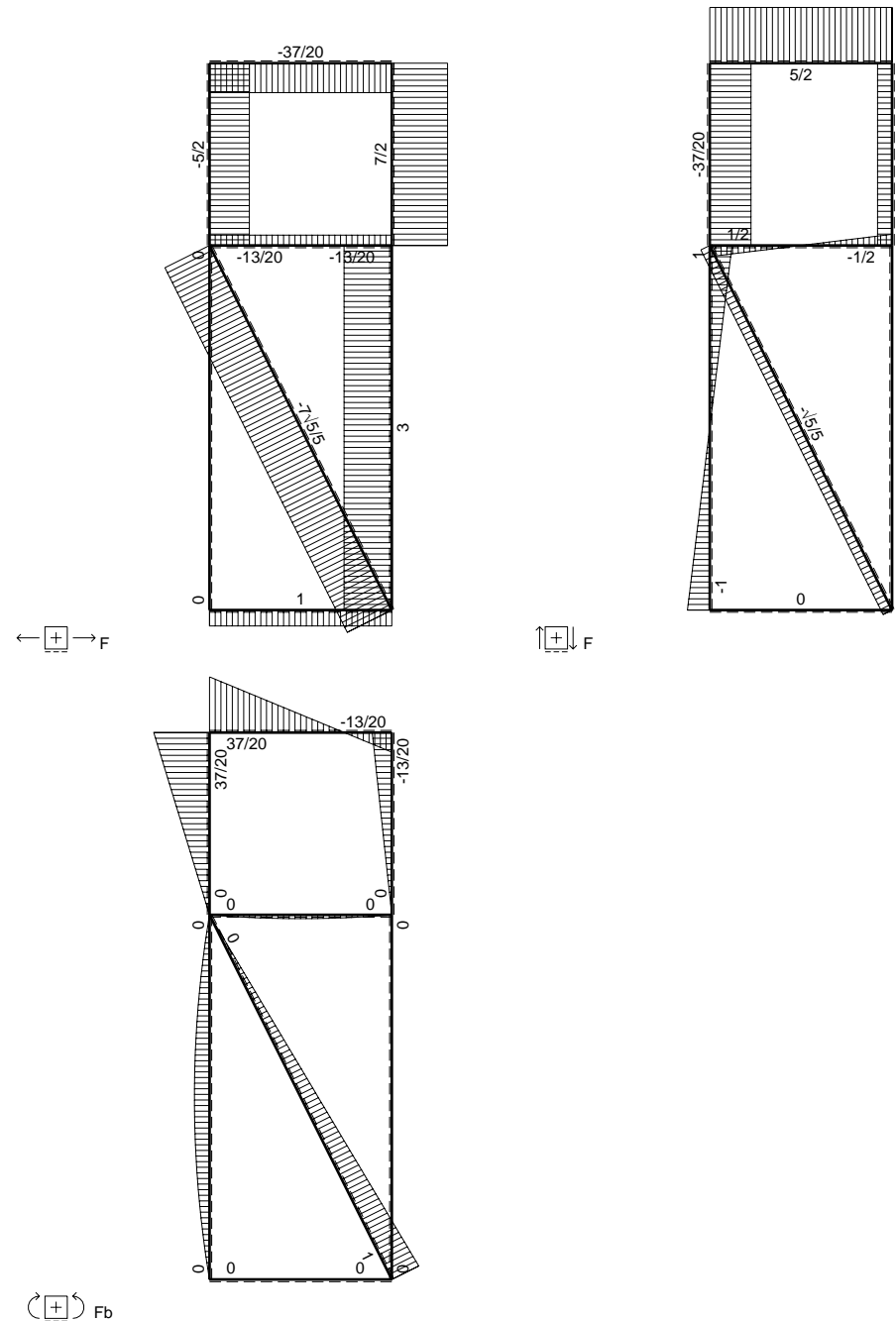
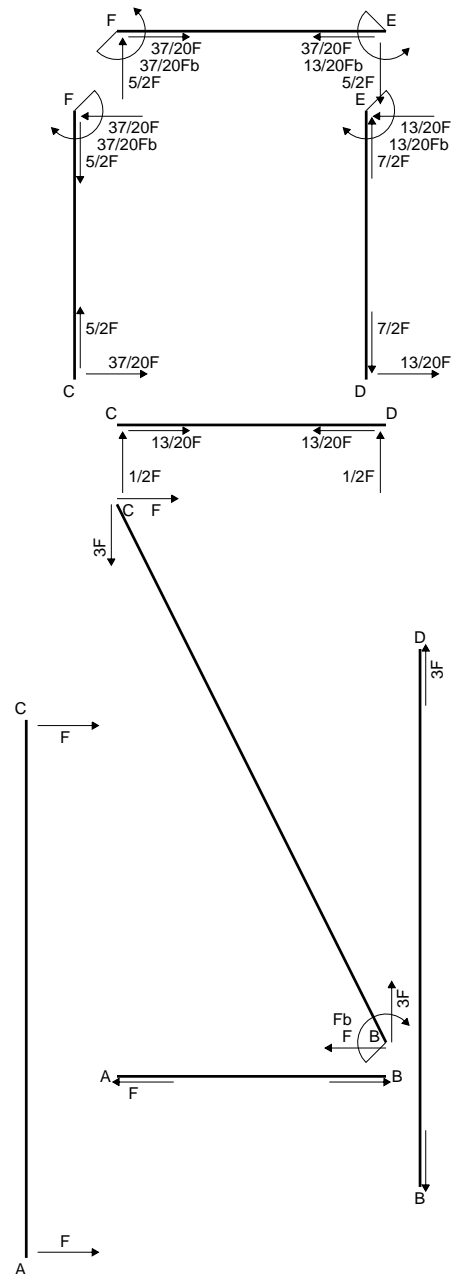

$$L_{DE}^{xx} = \int_0^b (x^2/b^2) 1/EJ dx = [1/3 x^3/b^2]_0^b 1/EJ$$

$$= (1/3 b) 1/EJ = 1/3 b/EJ$$

$$L_{ED}^{xx} = \int_0^b (1 - 2x/b + x^2/b^2) 1/EJ dx = [x - x^2/b + 1/3 x^3/b^2]_0^b 1/EJ$$

$$= (b - b + 1/3 b) 1/EJ = 1/3 b/EJ$$

$$L_{EF}^{xx} = \int_0^b (1) 1/EJ dx = [x]_0^b 1/EJ$$

$$= (b) 1/EJ = b/EJ$$

$$L_{FE}^{xx} = \int_0^b (1) 1/EJ dx = [x]_0^b 1/EJ$$

$$= (b) 1/EJ = b/EJ$$

$$L_{FC}^{xx} = \int_0^b (1 - 2x/b + x^2/b^2) 1/EJ dx = [x - x^2/b + 1/3 x^3/b^2]_0^b 1/EJ$$

$$= (b - b + 1/3 b) 1/EJ = 1/3 b/EJ$$

$$L_{CF}^{xx} = \int_0^b (x^2/b^2) 1/EJ dx = [1/3 x^3/b^2]_0^b 1/EJ$$

$$= (1/3 b) 1/EJ = 1/3 b/EJ$$

$$L_{EF}^{xo} = \int_0^b (-5/2 x/b) Fb 1/EJ dx + \int_0^b (1) \theta dx = [-5/4 x^2/b]_0^b Fb 1/EJ + [x]_0^b \theta$$

$$= (-5/4 b) Fb 1/EJ + (b) \theta = -1/4 Fb^2/EJ$$

$$L_{FE}^{xo} = \int_0^b (-5/2 + 5/2 x/b) Fb 1/EJ dx + \int_0^b (-1) \theta dx = [-5/2 x + 5/4 x^2/b]_0^b Fb 1/EJ + [-x]_0^b \theta$$

$$= (-5/2 b + 5/4 b) Fb 1/EJ + (-b) \theta = -1/4 Fb^2/EJ$$

$$L_{FC}^{xo} = \int_0^b (-5/2 + 5x/b - 5/2 x^2/b^2) Fb 1/EJ dx = [-5/2 x + 5/2 x^2/b - 5/6 x^3/b^2]_0^b Fb 1/EJ$$

$$= (-5/2 b + 5/2 b - 5/6 b) Fb 1/EJ = -5/6 Fb^2/EJ$$

$$L_{CF}^{xo} = \int_0^b (-5/2 x^2/b^2) Fb 1/EJ dx = [-5/6 x^3/b^2]_0^b Fb 1/EJ$$

$$= (-5/6 b) Fb 1/EJ = -5/6 Fb^2/EJ$$

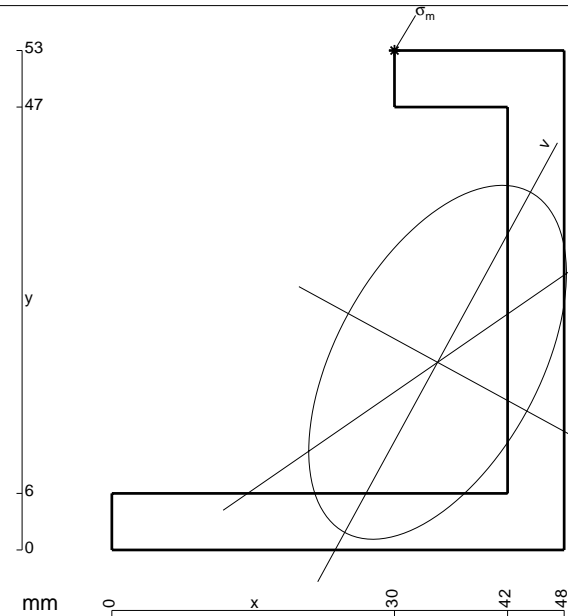

- A = 642. mm²
- J_x = 226469. mm⁴
- J_y = 120007. mm⁴
- J_{xy} = 82782. mm⁴
- J_u = 271657. mm⁴
- J_v = 74819. mm⁴
- α = arctg(2J_{xy}/(J_v-J_x))/2 = -.4997
- c = cos α = .8777
- s = sin α = -.4791
- x_g = 34.57 mm
- y_g = 19.91 mm
- N = -2200. N
- T_y = -1628. N
- M_x = 960520. Nmm
- x_m = 30. mm
- y_m = 53. mm
- u_m = -19.87 mm
- v_m = 26.85 mm
- σ_m = N/A-Mcv/J_u-Msv/J_v = -209. N/mm²

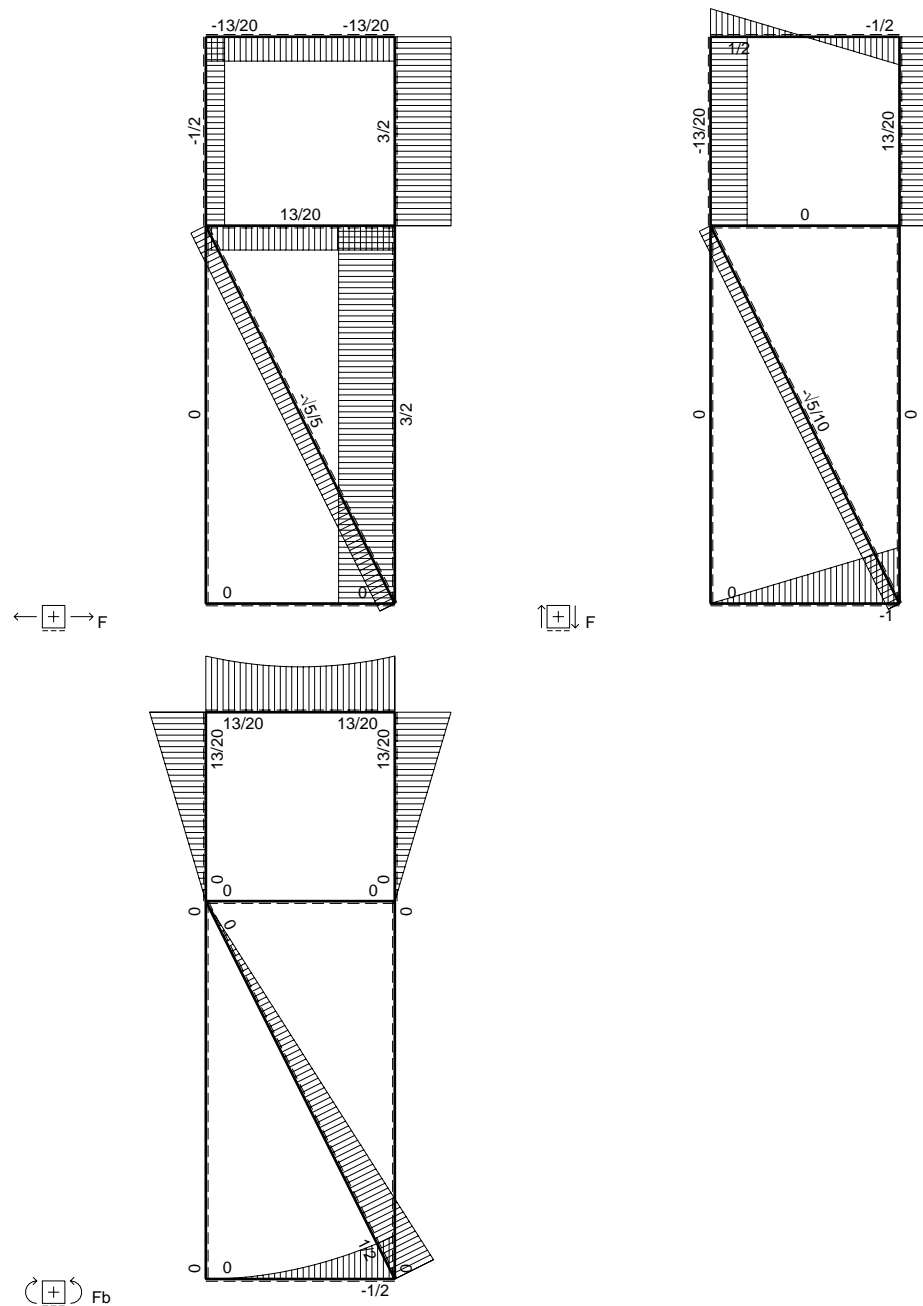
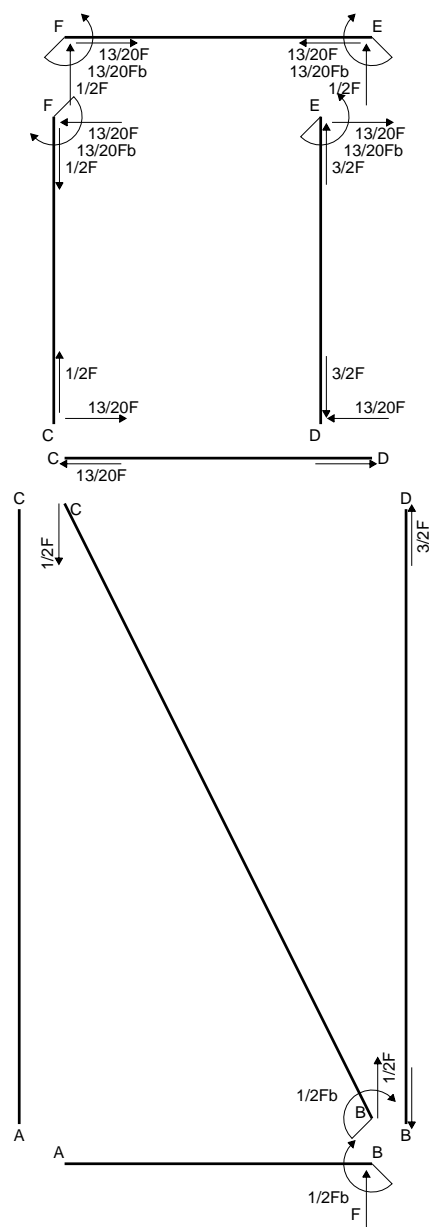

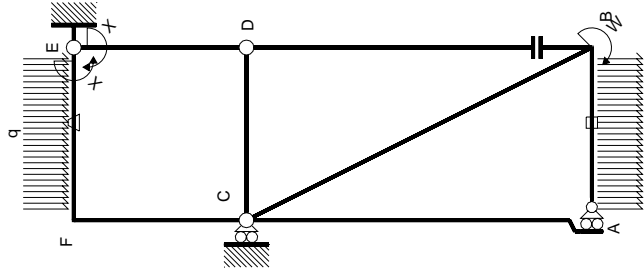

Schema di calcolo iperstatico

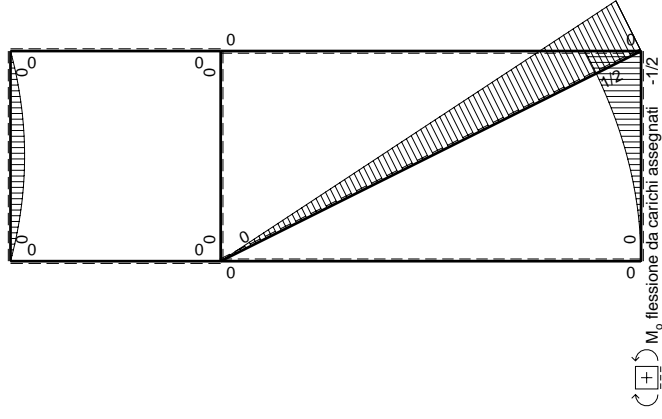

Quadro contributi PLV per iperstatica $X=W_{EP}$

\leftarrow	$M_x(x)$	$M_0(x)$	θ	$M_x M_0$	$M_x \theta$	$M_x M_x$	$\int M_x(M_0/EJ+\theta)dx$	$\int M_x M_x/EJ dx$
AB b	0	$-1/2qx^2$	0	0	0	0	0+0	0
BA b	0	$1/2Fb-Fx+1/2qx^2$	0	0	0	0	0	0
BC $\sqrt{5}b$	0	$1/2Fb-\sqrt{5}/10Fx$	0	0	0	0	0	0
AC 2b	0	0	0	0	0	0	0+0	0
CA 2b	0	0	0	0	0	0	0	0
DB 2b	0	0	0	0	0	0	0+0	0
BD 2b	0	0	0	0	0	0	0	0
DE b	-x/b	0	0	0	0	0	0+0	1/3Xb/EJ
ED b	1-x/b	0	0	0	0	0	0+0	1/3Xb/EJ
CD b	0	0	0	0	0	0	0	0
DC b	0	0	0	0	0	0	0+0	0
EF b	-1	$-1/2Fx+1/2qx^2$	-Fb/EJ	$1/2Fx-1/2Fx^2/b$	Fb/EJ	1	$(1/12+1)Fb^2/EJ$	Xb/EJ
FE b	1	$1/2Fx-1/2qx^2$	Fb/EJ	$1/2Fx-1/2Fx^2/b$	Fb/EJ	1	$(1/12+1)Fb^2/EJ$	Xb/EJ
FC b	-1+x/b	0	0	0	0	0	0+0	1/3Xb/EJ
CF b	x/b	0	0	0	0	0	0+0	1/3Xb/EJ
totali							$13/12Fb^2/EJ$	$5/3Xb/EJ$
								$-13/20Fb$

Sviluppi di calcolo iperstatica

$$L_{DE}^{xx} = \int_0^b (x^2/b^2) 1/EJ dx = [1/3 x^3/b^2]_0^b 1/EJ$$

$$= (1/3 b) 1/EJ = 1/3 b/EJ$$

$$L_{ED}^{xx} = \int_0^b (1 - 2x/b + x^2/b^2) 1/EJ dx = [x - x^2/b + 1/3 x^3/b^2]_0^b 1/EJ$$

$$= (b - b + 1/3 b) 1/EJ = 1/3 b/EJ$$

$$L_{EF}^{xx} = \int_0^b (1) 1/EJ dx = [x]_0^b 1/EJ$$

$$= (b) 1/EJ = b/EJ$$

$$L_{FE}^{xx} = \int_0^b (1) 1/EJ dx = [x]_0^b 1/EJ$$

$$= (b) 1/EJ = b/EJ$$

$$L_{FC}^{xx} = \int_0^b (1 - 2x/b + x^2/b^2) 1/EJ dx = [x - x^2/b + 1/3 x^3/b^2]_0^b 1/EJ$$

$$= (b - b + 1/3 b) 1/EJ = 1/3 b/EJ$$

$$L_{CF}^{xx} = \int_0^b (x^2/b^2) 1/EJ dx = [1/3 x^3/b^2]_0^b 1/EJ$$

$$= (1/3 b) 1/EJ = 1/3 b/EJ$$

$$L_{EF}^{xo} = \int_0^b (1/2 x/b - 1/2 x^2/b^2) Fb 1/EJ dx + \int_0^b (1) \theta dx = [1/4 x^2/b - 1/6 x^3/b^2]_0^b Fb 1/EJ + [x]_0^b \theta$$

$$= (1/4 b - 1/6 b) Fb 1/EJ + (b) \theta = 13/12 Fb^2/EJ$$

$$L_{FE}^{xo} = \int_0^b (1/2 x/b - 1/2 x^2/b^2) Fb 1/EJ dx + \int_0^b (-1) \theta dx = [1/4 x^2/b - 1/6 x^3/b^2]_0^b Fb 1/EJ + [-x]_0^b \theta$$

$$= (1/4 b - 1/6 b) Fb 1/EJ + (-b) \theta = 13/12 Fb^2/EJ$$

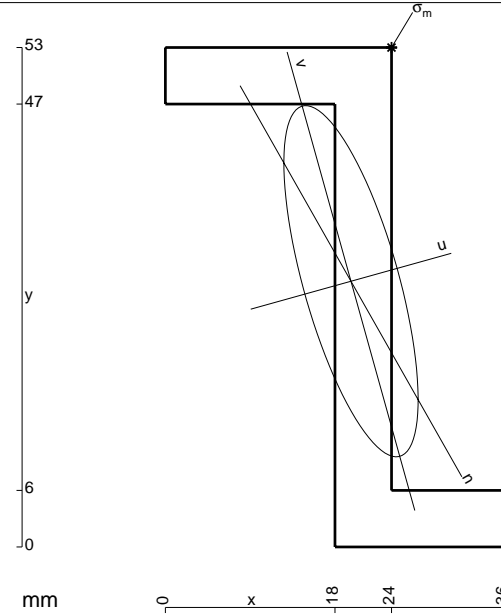

- A = 498. mm²
- J_x = 172946. mm⁴
- J_y = 25275. mm⁴
- J_{xy} = -44583. mm⁴
- J_u = 185362. mm⁴
- J_v = 12859. mm⁴
- α = arctg(2J_{xy}/(J_y-J_x))/2 = .2716
- c = cos α = .9633
- s = sin α = .2683
- x_g = 19.7 mm
- y_g = 28.2 mm
- N = -1021. N
- T_y = -785. N
- M_x = 632710. Nmm
- x_m = 24. mm
- y_m = 53. mm
- u_m = 10.8 mm
- v_m = 22.74 mm
- σ_m = N/A - Mc_v/J_u - Ms_u/J_v = -219.4 N/mm²

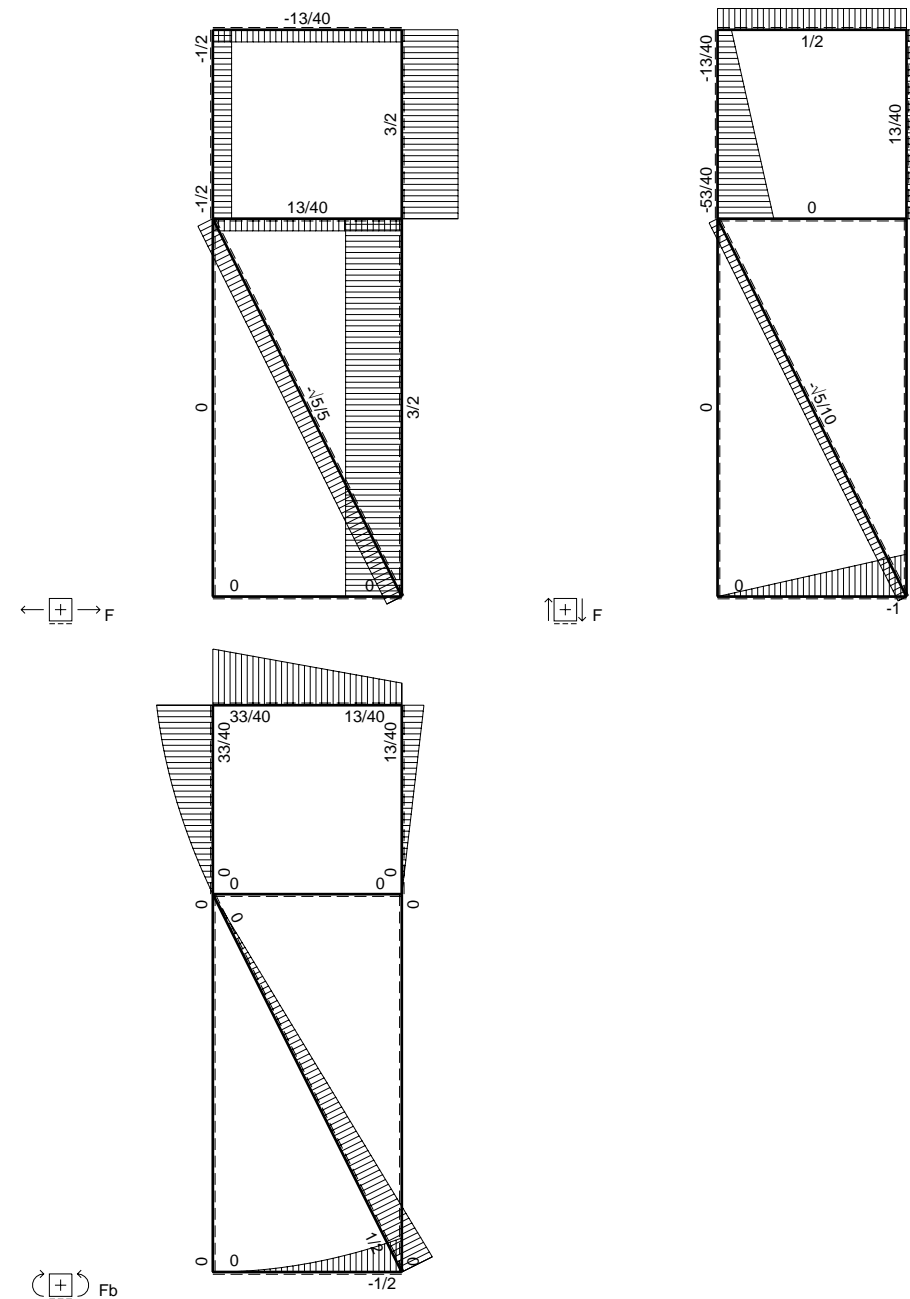
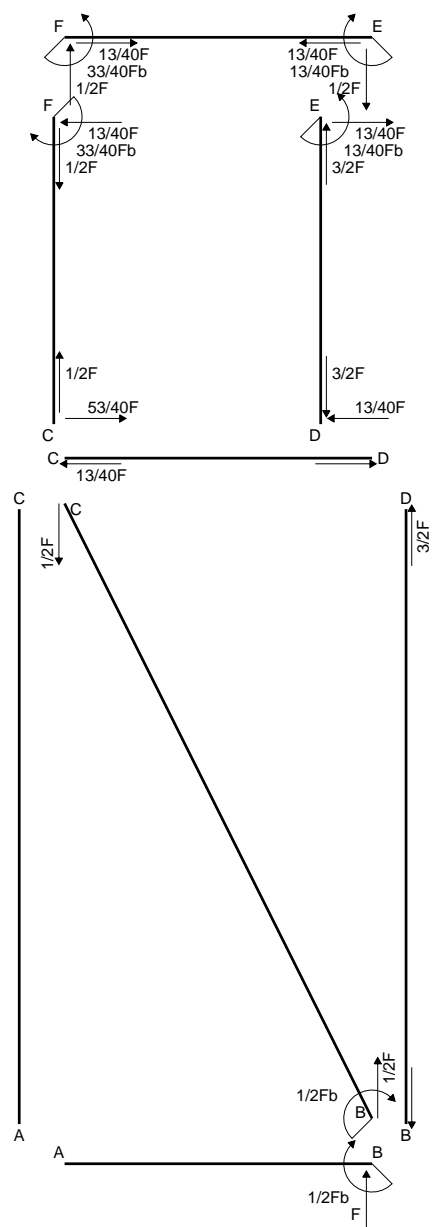

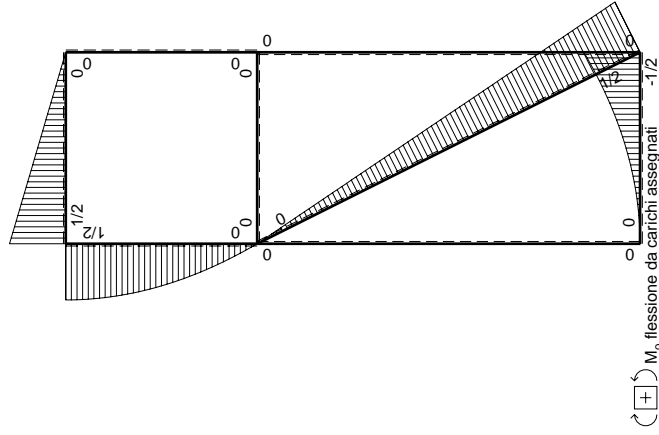
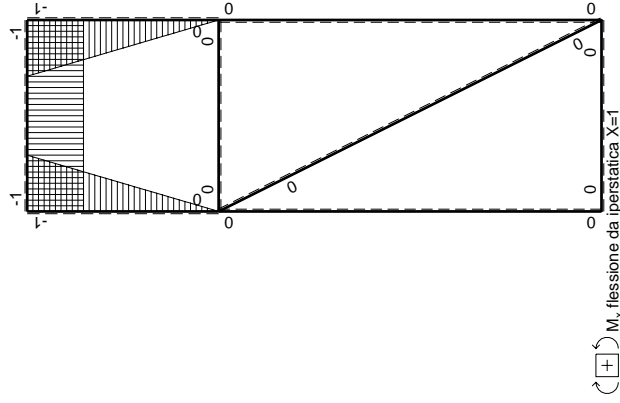
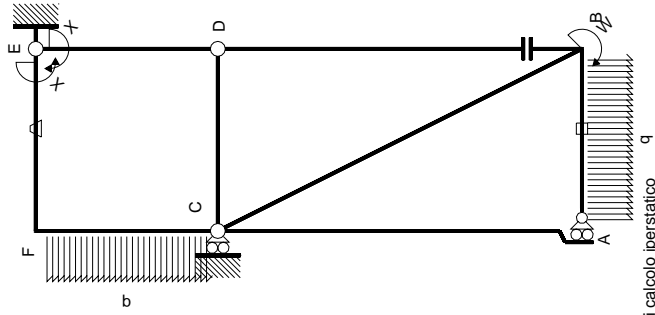

Quadro contributi PLV per iperstatica $X=W_{EF}$		$M_x(x)$		$M_0(x)$		$M_x\theta$	M_xM_x	$\int M_x(M_0/EJ+\theta)dx$	$\int M_xM_x/EJdx$
AB b	0	$-1/2qx^2$	0	0	0	0	0	0+0	0
BA b	0	$1/2Fb-Fx+1/2qx^2$	0	0	0	0	0	0	0
BC $\sqrt{5}b$	0	$1/2Fb-\sqrt{5}/10Fx$	0	0	0	0	0	0	0
AC 2b	0	0	0	0	0	0	0	0+0	0
CA 2b	0	0	0	0	0	0	0	0	0
DB 2b	0	0	0	0	0	0	0	0+0	0
BD 2b	0	0	0	0	0	0	0	0	0
DE b	-x/b	0	0	0	0	0	x^2/b^2	0+0	0
ED b	$1-x/b$	0	0	0	0	0	$1-2x/b+x^2/b^2$	0+0	$1/3xb/EJ$
CD b	0	0	0	0	0	0	0	0	0
DC b	0	0	0	0	0	0	0	0+0	0
EF b	-1	$1/2Fx$	$-Fb/EJ$	$-1/2Fx$	Fb/EJ	Fb/EJ	1	$(-1/4+1)Fb^2/EJ$	xb/EJ
FE b	1	$-1/2Fb+1/2Fx$	Fb/EJ	$-1/2Fb+1/2Fx$	Fb/EJ	Fb/EJ	1	$(-1/4+1)Fb^2/EJ$	xb/EJ
FC b	$-1+x/b$	$1/2Fb-1/2qx^2$	0	$-1/2Fb+1/2Fx+1/2Fx^2/b-1/2qx^3/b$	0	0	$1-2x/b+x^2/b^2$	$(-5/24+0)Fb^2/EJ$	$1/3xb/EJ$
CF b	x/b	$-Fx+1/2qx^2$	0	$-Fx^2/b+1/2qx^3/b$	0	0	x^2/b^2	$13/24Fb^2/EJ$	$5/3xb/EJ$
totali								$-13/40Fb$	

Sviluppi di calcolo iperstatica

$$L_{DE}^{xx} = \int_0^b (x^2/b^2) 1/EJ dx = [1/3 x^3/b^2]_0^b 1/EJ$$

$$= (1/3 b) 1/EJ = 1/3 b/EJ$$

$$L_{ED}^{xx} = \int_0^b (1 - 2x/b + x^2/b^2) 1/EJ dx = [x - x^2/b + 1/3 x^3/b^2]_0^b 1/EJ$$

$$= (b - b + 1/3 b) 1/EJ = 1/3 b/EJ$$

$$L_{EF}^{xx} = \int_0^b (1) 1/EJ dx = [x]_0^b 1/EJ$$

$$= (b) 1/EJ = b/EJ$$

$$L_{FE}^{xx} = \int_0^b (1) 1/EJ dx = [x]_0^b 1/EJ$$

$$= (b) 1/EJ = b/EJ$$

$$L_{FC}^{xx} = \int_0^b (1 - 2x/b + x^2/b^2) 1/EJ dx = [x - x^2/b + 1/3 x^3/b^2]_0^b 1/EJ$$

$$= (b - b + 1/3 b) 1/EJ = 1/3 b/EJ$$

$$L_{CF}^{xx} = \int_0^b (x^2/b^2) 1/EJ dx = [1/3 x^3/b^2]_0^b 1/EJ$$

$$= (1/3 b) 1/EJ = 1/3 b/EJ$$

$$L_{EF}^{xo} = \int_0^b (-1/2 x/b) Fb 1/EJ dx + \int_0^b (1) \theta dx = [-1/4 x^2/b]_0^b Fb 1/EJ + [x]_0^b \theta$$

$$= (-1/4 b) Fb 1/EJ + (b) \theta = 3/4 Fb^2/EJ$$

$$L_{FE}^{xo} = \int_0^b (-1/2 + 1/2 x/b) Fb 1/EJ dx + \int_0^b (-1) \theta dx = [-1/2 x + 1/4 x^2/b]_0^b Fb 1/EJ + [-x]_0^b \theta$$

$$= (-1/2 b + 1/4 b) Fb 1/EJ + (-b) \theta = 3/4 Fb^2/EJ$$

$$L_{FC}^{xo} = \int_0^b (-1/2 + 1/2 x/b + 1/2 x^2/b^2 - 1/2 x^3/b^3) Fb 1/EJ dx$$

$$= [-1/2 x + 1/4 x^2/b + 1/6 x^3/b^2 - 1/8 x^4/b^3]_0^b Fb 1/EJ$$

$$= (-1/2 b + 1/4 b + 1/6 b - 1/8 b) Fb 1/EJ = -5/24 Fb^2/EJ$$

$$L_{CF}^{xo} = \int_0^b (-x^2/b^2 + 1/2 x^3/b^3) Fb 1/EJ dx = [-1/3 x^3/b^2 + 1/8 x^4/b^3]_0^b Fb 1/EJ$$

$$= (-1/3 b + 1/8 b) Fb 1/EJ = -5/24 Fb^2/EJ$$

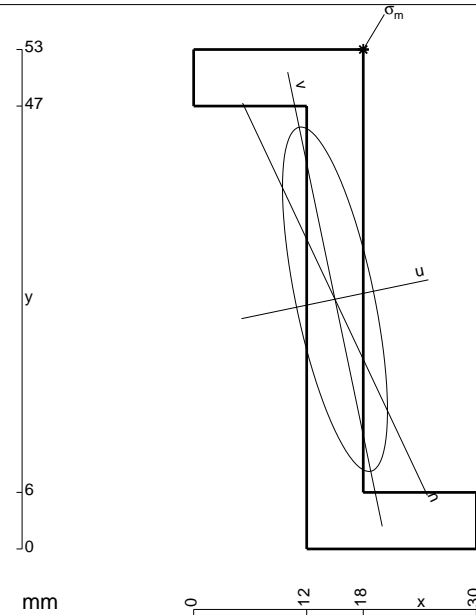

- A = 462. mm²
- J_x = 154395. mm⁴
- J_y = 14346. mm⁴
- J_{xy} = -30456. mm⁴
- J_u = 160731. mm⁴
- J_v = 8010. mm⁴
- α = arctg(2J_{xy}/(J_y-J_x))/2 = .2051
- c = cos α = .9790
- s = sin α = .2037
- x_g = 15. mm
- y_g = 26.5 mm
- N = -570. N
- T_y = -370.5 N
- M_x = 620730. Nmm
- x_m = 18. mm
- y_m = 53. mm
- u_m = 8.335 mm
- v_m = 25.33 mm
- σ_m = N/A - Mc_v/J_u - Ms_u/J_v = -228.6 N/mm²

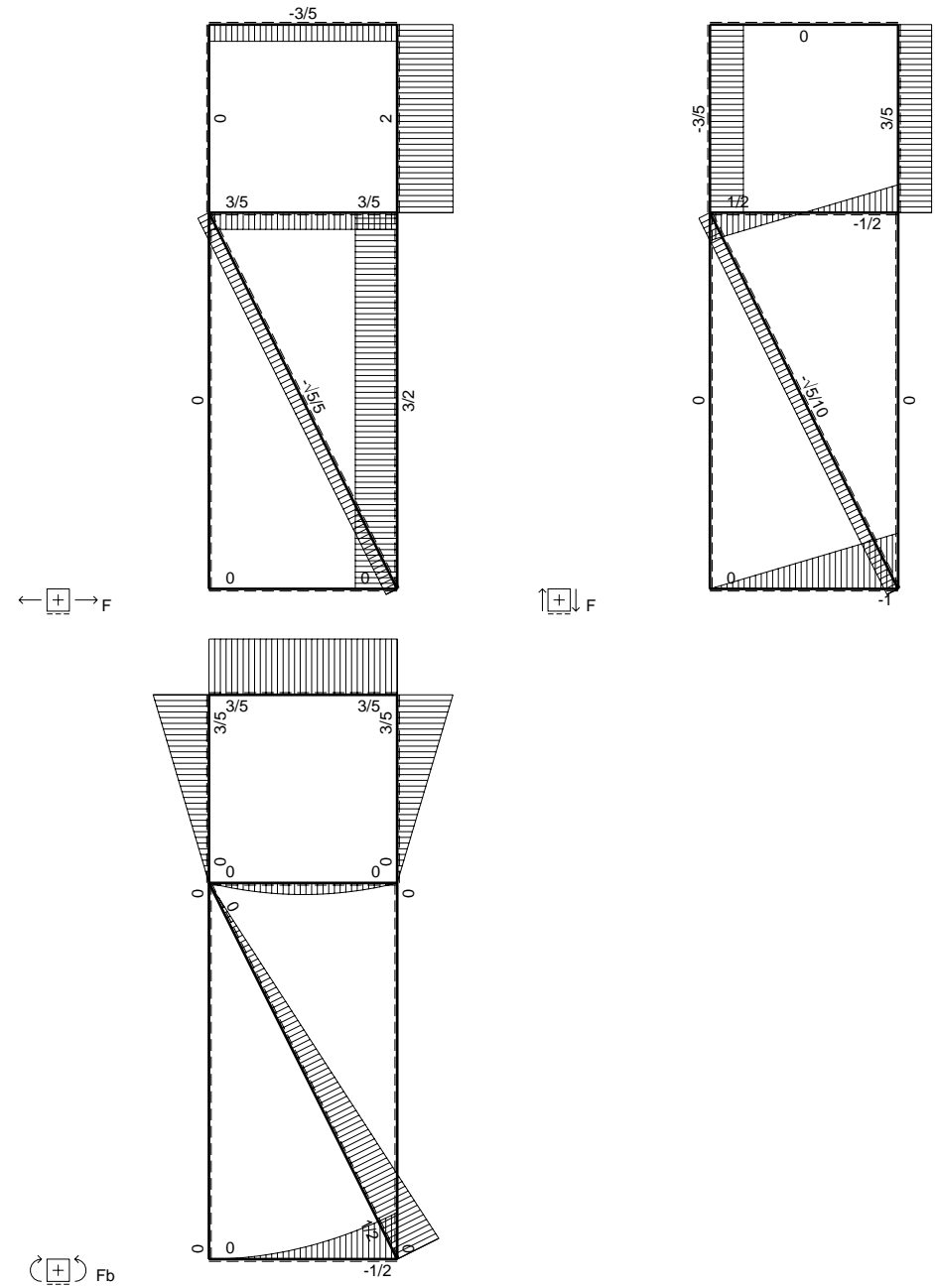
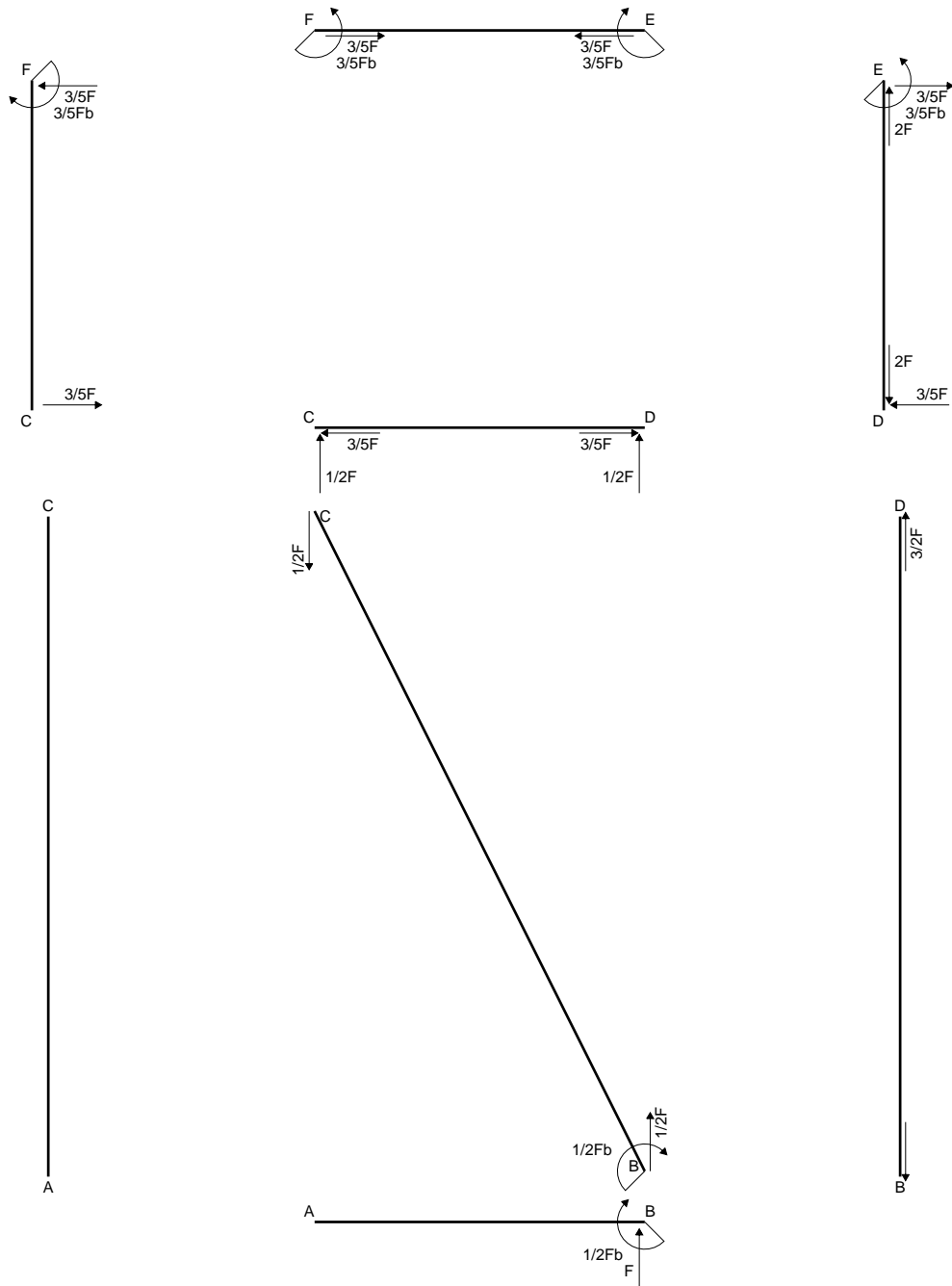

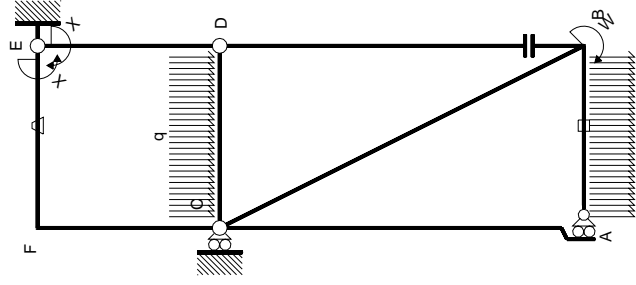

Schema di calcolo iperstatico

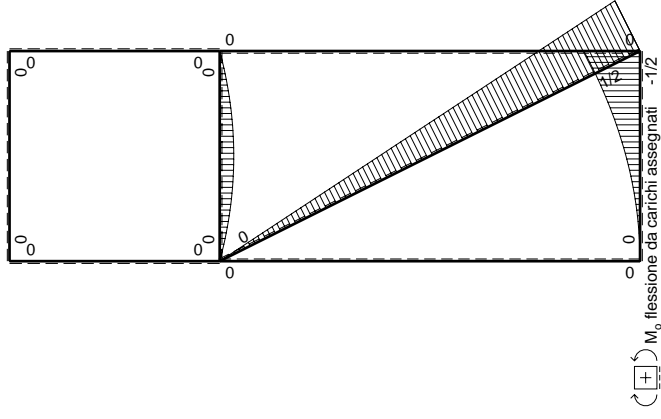

M_0 flessione da carichi assegnati -1/2

Quadro contributi PLV per iperstatica $X=W_{EF}$

\rightarrow	$M_x(x)$	$M_0(x)$	θ	$M_x M_0$	$M_x \theta$	$M_x M_x$	$\int M_x(M_0/EJ+\theta)dx$	$\int X M_x M_x / EJ dx$
AB b	0	$-1/2qx^2$	0	0	0	0	0+0	0
BA b	0	$1/2Fb-Fx+1/2qx^2$	0	0	0	0	0+0	0
BC $\sqrt{5}b$	0	$1/2Fb-\sqrt{5}/10Fx$	0	0	0	0	0	0
AC 2b	0	0	0	0	0	0	0+0	0
CA 2b	0	0	0	0	0	0	0+0	0
DB 2b	0	0	0	0	0	0	0+0	0
BD 2b	0	0	0	0	0	0	0+0	0
DE b	$-x/b$	0	0	0	0	x^2/b^2	0+0	$1/3Xb/EJ$
ED b	$1-x/b$	0	0	0	0	$1-2x/b+x^2/b^2$	0+0	$1/3Xb/EJ$
CD b	0	$1/2Fx-1/2qx^2$	0	0	0	0	0+0	0
DC b	0	$-1/2Fx+1/2qx^2$	0	0	0	0	0+0	0
EF b	-1	0	$-Fb/EJ$	0	Fb/EJ	1	$(0+1)Fb^2/EJ$	Xb/EJ
FE b	1	0	Fb/EJ	0	Fb/EJ	1		
FC b	$-1+x/b$	0	0	0	0	$1-2x/b+x^2/b^2$	0+0	$1/3Xb/EJ$
CF b	x/b	0	0	0	0	x^2/b^2	0+0	$1/3Xb/EJ$
	totali						Fb^2/EJ	$5/3Xb/EJ$
	iperstatica $X=W_{EF}$						$-3/5Fb$	

Sviluppi di calcolo iperstatica

M_x flessione da iperstatica $X=1$



$$L_{DE}^{xx} = \int_0^b (x^2/b^2) 1/EJ dx = [1/3 x^3/b^2]_0^b 1/EJ$$

$$= (1/3 b) 1/EJ = 1/3 b/EJ$$

$$L_{ED}^{xx} = \int_0^b (1 - 2x/b + x^2/b^2) 1/EJ dx = [x - x^2/b + 1/3 x^3/b^2]_0^b 1/EJ$$

$$= (b - b + 1/3 b) 1/EJ = 1/3 b/EJ$$

$$L_{EF}^{xx} = \int_0^b (1) 1/EJ dx = [x]_0^b 1/EJ$$

$$= (b) 1/EJ = b/EJ$$

$$L_{FE}^{xx} = \int_0^b (1) 1/EJ dx = [x]_0^b 1/EJ$$

$$= (b) 1/EJ = b/EJ$$

$$L_{FC}^{xx} = \int_0^b (1 - 2x/b + x^2/b^2) 1/EJ dx = [x - x^2/b + 1/3 x^3/b^2]_0^b 1/EJ$$

$$= (b - b + 1/3 b) 1/EJ = 1/3 b/EJ$$

$$L_{CF}^{xx} = \int_0^b (x^2/b^2) 1/EJ dx = [1/3 x^3/b^2]_0^b 1/EJ$$

$$= (1/3 b) 1/EJ = 1/3 b/EJ$$

$$L_{EF}^{xo} = \int_0^b (1) \theta dx = [x]_0^b \theta$$

$$= (b) \theta = Fb^2/EJ$$

$$L_{FE}^{xo} = \int_0^b (-1) \theta dx = [-x]_0^b \theta$$

$$= (-b) \theta = Fb^2/EJ$$

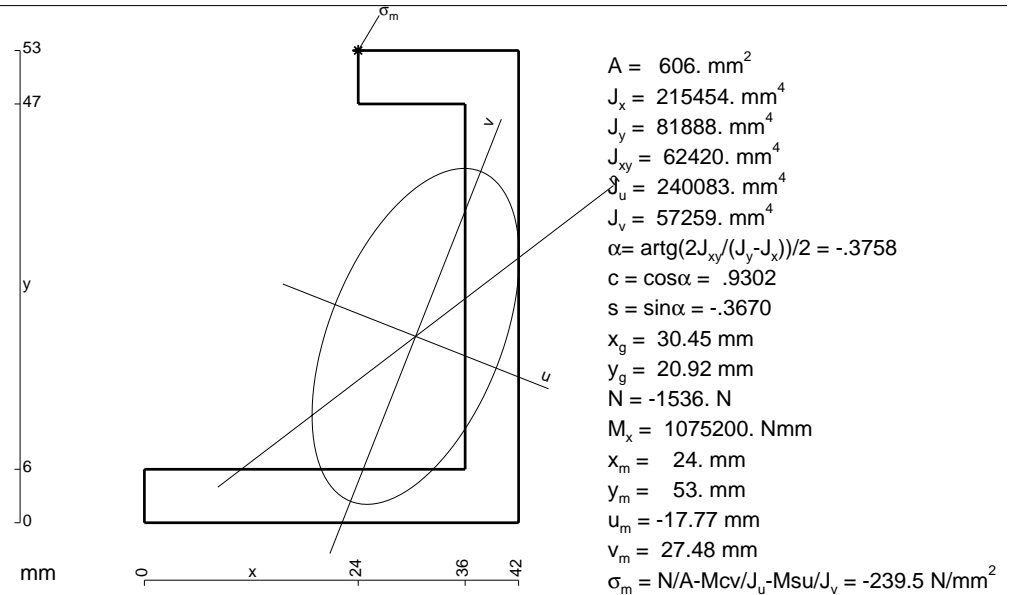

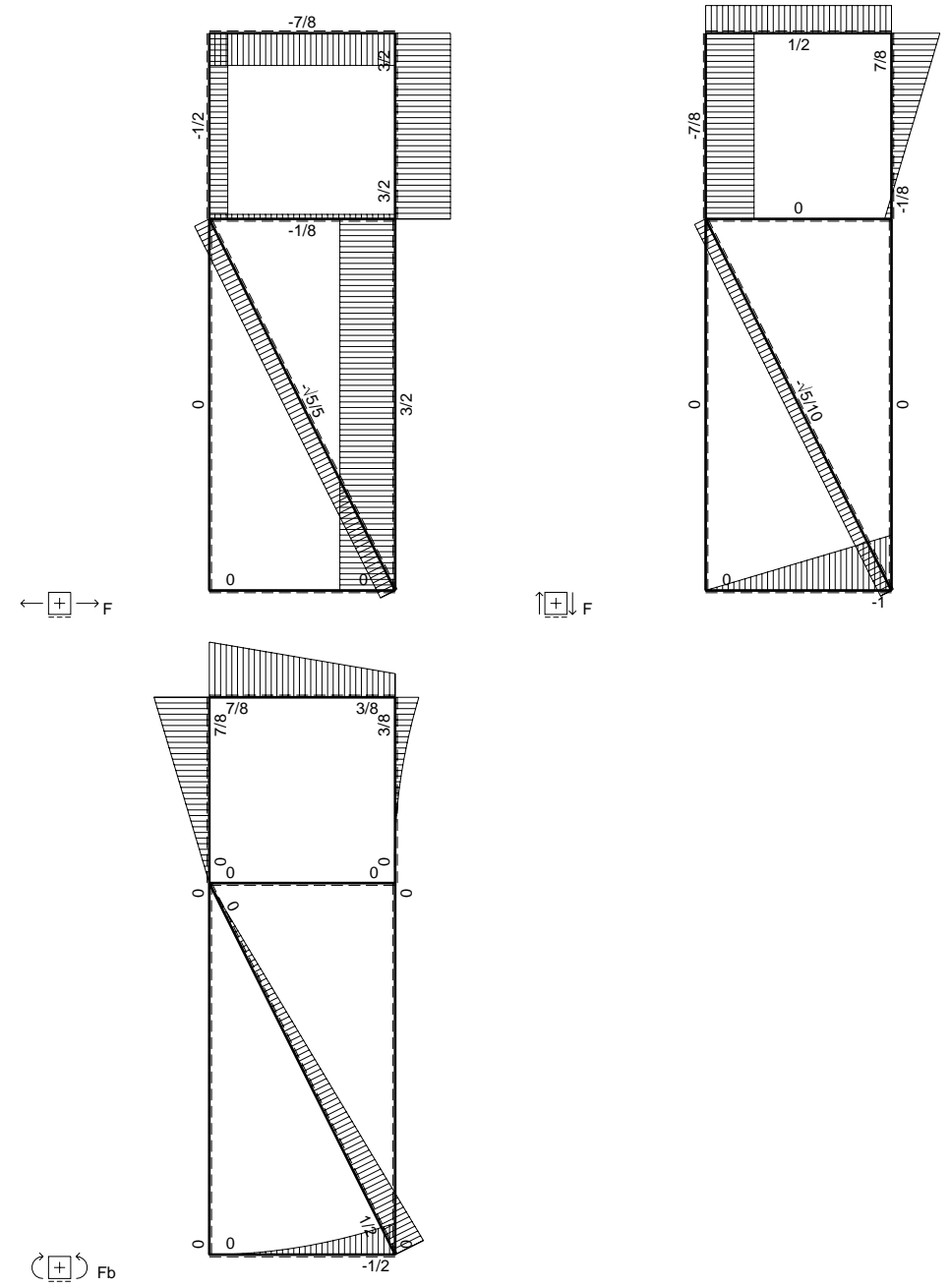
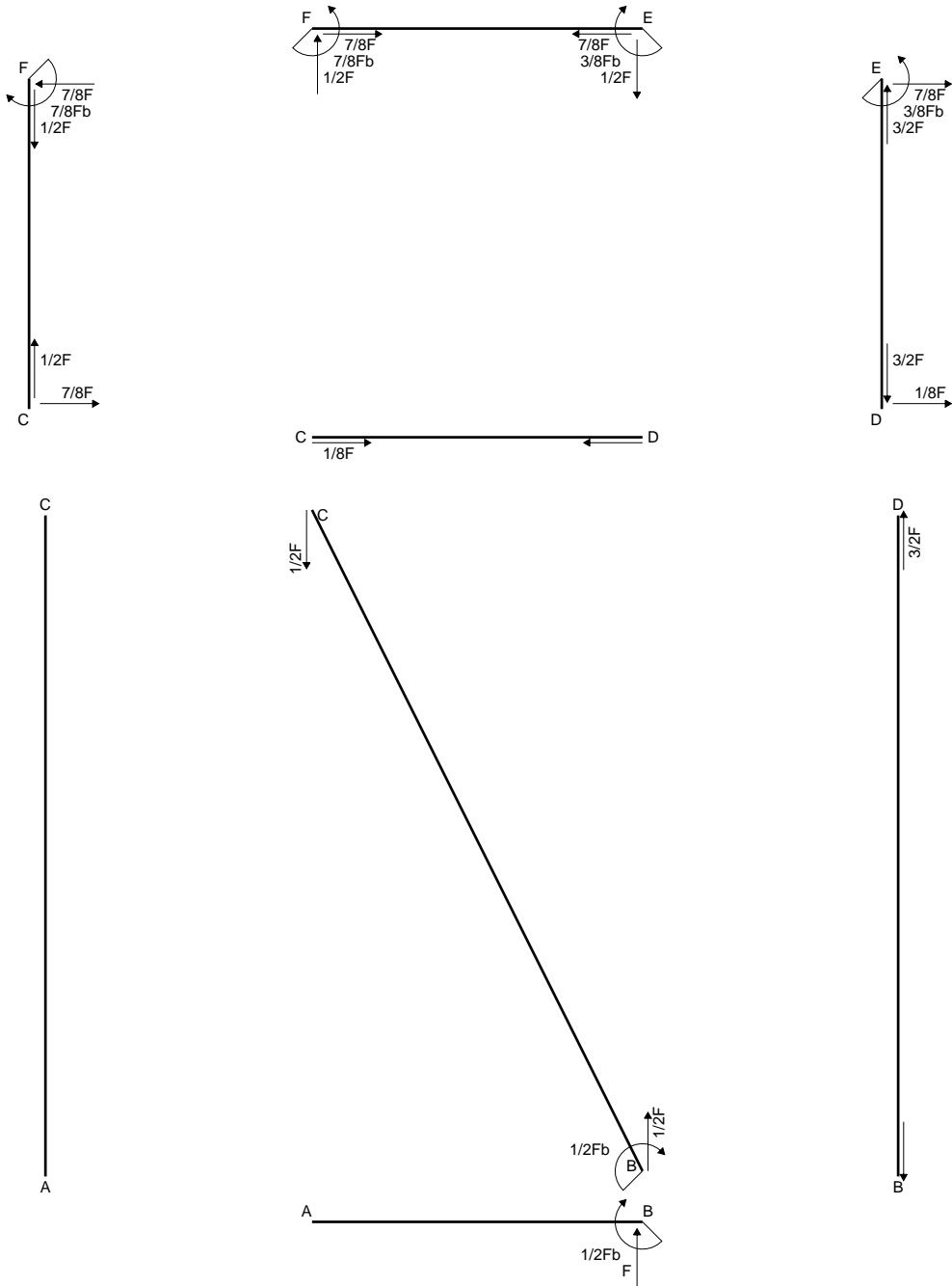

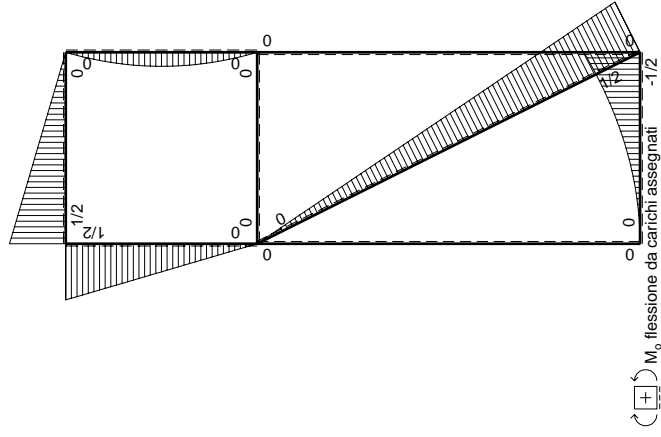
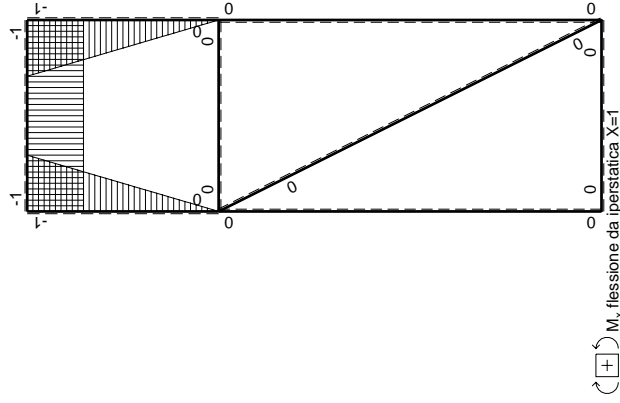
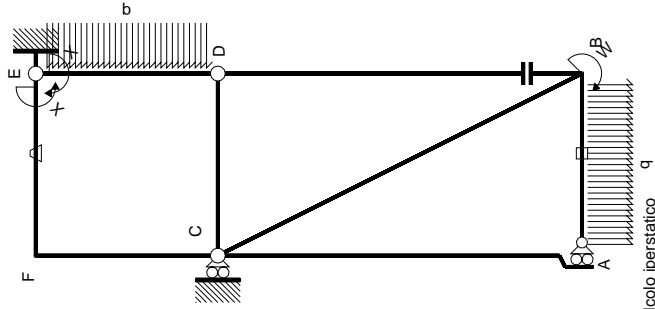

Quadro contributi PLV per iperstatica $X=W_{EF}$

\rightarrow	$M^k(x)$	$M^0(x)$	θ	$M^x M_0$	$M^x \theta$	$M^x M_x$	$\int M^x (M_0/EJ + \theta) dx$	$\int M^x M_x / EJ dx$
AB b	0	$-1/2qx^2$	0	0	0	0	0+0	0
BA b	0	$1/2Fb-Fx+1/2qx^2$	0	0	0	0	0	0
BC $\sqrt{5}b$	0	$1/2Fb-\sqrt{5}/10Fx$	0	0	0	0	0+0	0
CA 2b	0	0	0	0	0	0	0+0	0
DB 2b	0	0	0	0	0	0	0+0	0
BD 2b	0	0	0	0	0	0	0+0	0
DE b	$-x/b$	$-1/2Fx+1/2qx^2$	0	$1/2F^2x^2/b-1/2qx^3/b$	0	0	x^2/b^2	0
ED b	$1-x/b$	$1/2Fx-1/2qx^2$	0	$1/2Fx-Fx^2/b+1/2qx^3/b$	0	0	$1-2x/b+x^2/b^2$	$1/3xb/EJ$
CD b	0	0	0	0	0	0	0+0	0
DC b	0	0	0	0	0	0	0+0	0
EF b	-1	$1/2Fx$	$-Fb/EJ$	$-1/2Fx$	Fb/EJ	1	$(-1/4+1)Fb^2/EJ$	xb/EJ
FE b	1	$-1/2Fb+1/2Fx$	Fb/EJ	$-1/2Fb+1/2Fx$	Fb/EJ	1	$(-1/4+1)Fb^2/EJ$	xb/EJ
FC b	$-1+x/b$	$1/2Fb-1/2Fx$	0	$-1/2Fb+Fx-1/2Fx^2/b$	0	0	$1-2x/b+x^2/b^2$	$1/3xb/EJ$
CF b	x/b	$-1/2Fx$	0	$-1/2Fx^2/b$	0	0	x^2/b^2	$1/3xb/EJ$
totali								$5/8Fb^2/EJ$
								$-3/8Fb$

Sviluppi di calcolo iperstatica

$$L_{DE}^{xx} = \int_0^b (x^2/b^2) 1/EJ dx = [1/3 x^3/b^2]_0^b 1/EJ$$

$$= (1/3 b) 1/EJ = 1/3 b/EJ$$

$$L_{ED}^{xx} = \int_0^b (1 - 2x/b + x^2/b^2) 1/EJ dx = [x - x^2/b + 1/3 x^3/b^2]_0^b 1/EJ$$

$$= (b - b + 1/3 b) 1/EJ = 1/3 b/EJ$$

$$L_{EF}^{xx} = \int_0^b (1) 1/EJ dx = [x]_0^b 1/EJ$$

$$= (b) 1/EJ = b/EJ$$

$$L_{FE}^{xx} = \int_0^b (1) 1/EJ dx = [x]_0^b 1/EJ$$

$$= (b) 1/EJ = b/EJ$$

$$L_{FC}^{xx} = \int_0^b (1 - 2x/b + x^2/b^2) 1/EJ dx = [x - x^2/b + 1/3 x^3/b^2]_0^b 1/EJ$$

$$= (b - b + 1/3 b) 1/EJ = 1/3 b/EJ$$

$$L_{CF}^{xx} = \int_0^b (x^2/b^2) 1/EJ dx = [1/3 x^3/b^2]_0^b 1/EJ$$

$$= (1/3 b) 1/EJ = 1/3 b/EJ$$

$$L_{DE}^{xo} = \int_0^b (1/2 x^2/b^2 - 1/2 x^3/b^3) Fb 1/EJ dx = [1/6 x^3/b^2 - 1/8 x^4/b^3]_0^b Fb 1/EJ$$

$$= (1/6 b - 1/8 b) Fb 1/EJ = 1/24 Fb^2/EJ$$

$$L_{ED}^{xo} = \int_0^b (1/2 x/b - x^2/b^2 + 1/2 x^3/b^3) Fb 1/EJ dx = [1/4 x^2/b - 1/3 x^3/b^2 + 1/8 x^4/b^3]_0^b Fb 1/EJ$$

$$= (1/4 b - 1/3 b + 1/8 b) Fb 1/EJ = 1/24 Fb^2/EJ$$

$$L_{EF}^{xo} = \int_0^b (-1/2 x/b) Fb 1/EJ dx + \int_0^b (1) \theta dx = [-1/4 x^2/b]_0^b Fb 1/EJ + [x]_0^b \theta$$

$$= (-1/4 b) Fb 1/EJ + (b) \theta = 3/4 Fb^2/EJ$$

$$L_{FE}^{xo} = \int_0^b (-1/2 + 1/2 x/b) Fb 1/EJ dx + \int_0^b (-1) \theta dx = [-1/2 x + 1/4 x^2/b]_0^b Fb 1/EJ + [-x]_0^b \theta$$

$$= (-1/2 b + 1/4 b) Fb 1/EJ + (-b) \theta = 3/4 Fb^2/EJ$$

$$L_{FC}^{xo} = \int_0^b (-1/2 + x/b - 1/2 x^2/b^2) Fb 1/EJ dx = [-1/2 x + 1/2 x^2/b - 1/6 x^3/b^2]_0^b Fb 1/EJ$$

$$= (-1/2 b + 1/2 b - 1/6 b) Fb 1/EJ = -1/6 Fb^2/EJ$$

$$L_{CF}^{xo} = \int_0^b (-1/2 x^2/b^2) Fb 1/EJ dx = [-1/6 x^3/b^2]_0^b Fb 1/EJ$$

$$= (-1/6 b) Fb 1/EJ = -1/6 Fb^2/EJ$$

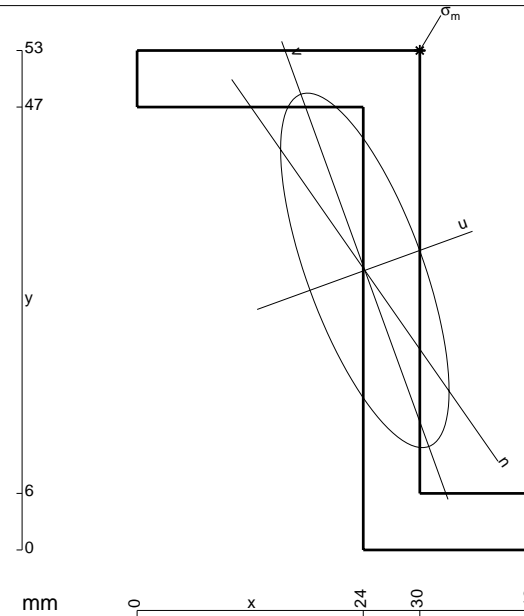

- A = 534. mm²
- J_x = 189011. mm⁴
- J_y = 42681. mm⁴
- J_{xy} = -61197. mm⁴
- J_u = 211231. mm⁴
- J_v = 20461. mm⁴
- α = arctg(2J_{xy}/(J_y-J_x))/2 = .3483
- c = cos α = .9400
- s = sin α = .3413
- x_g = 24.17 mm
- y_g = 29.67 mm
- N = -1698. N
- T_y = 970. N
- M_x = 628075. Nmm
- x_m = 30. mm
- y_m = 53. mm
- u_m = 13.44 mm
- v_m = 19.94 mm
- σ_m = N/A - Mcv/J_u - Msu/J_v = -199.7 N/mm²

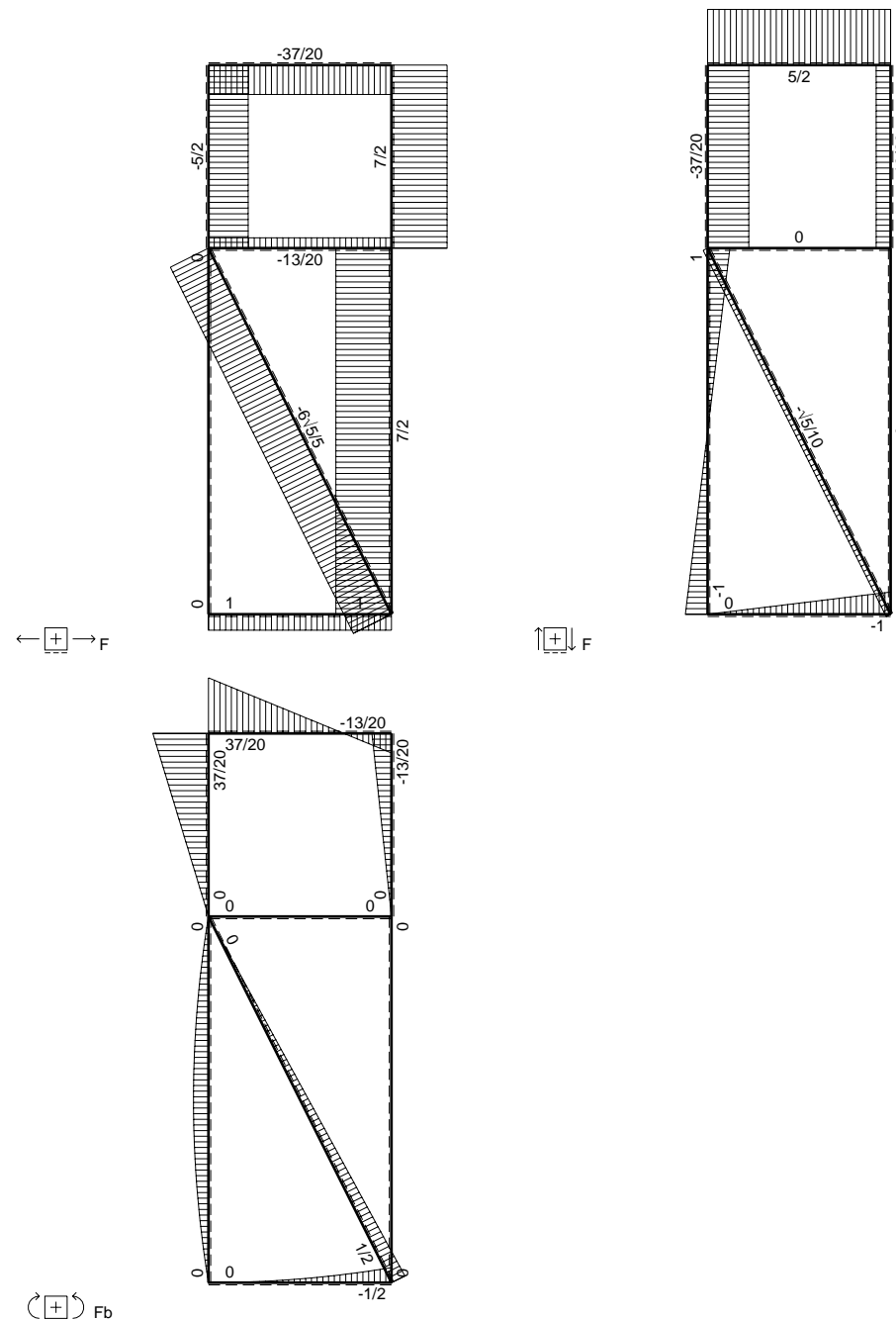
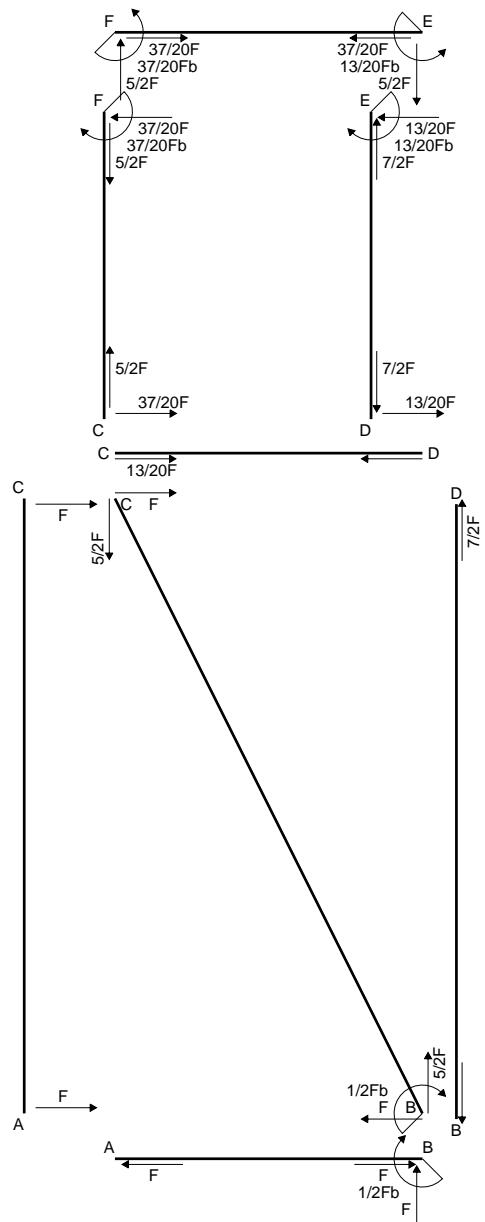

$$L_{DE}^{xx} = \int_0^b (x^2/b^2) 1/EJ dx = [1/3 x^3/b^2]_0^b 1/EJ$$

$$= (1/3 b) 1/EJ = 1/3 b/EJ$$

$$L_{ED}^{xx} = \int_0^b (1 - 2x/b + x^2/b^2) 1/EJ dx = [x - x^2/b + 1/3 x^3/b^2]_0^b 1/EJ$$

$$= (b - b + 1/3 b) 1/EJ = 1/3 b/EJ$$

$$L_{EF}^{xx} = \int_0^b (1) 1/EJ dx = [x]_0^b 1/EJ$$

$$= (b) 1/EJ = b/EJ$$

$$L_{FE}^{xx} = \int_0^b (1) 1/EJ dx = [x]_0^b 1/EJ$$

$$= (b) 1/EJ = b/EJ$$

$$L_{FC}^{xx} = \int_0^b (1 - 2x/b + x^2/b^2) 1/EJ dx = [x - x^2/b + 1/3 x^3/b^2]_0^b 1/EJ$$

$$= (b - b + 1/3 b) 1/EJ = 1/3 b/EJ$$

$$L_{CF}^{xx} = \int_0^b (x^2/b^2) 1/EJ dx = [1/3 x^3/b^2]_0^b 1/EJ$$

$$= (1/3 b) 1/EJ = 1/3 b/EJ$$

$$L_{EF}^{xo} = \int_0^b (-5/2 x/b) Fb 1/EJ dx + \int_0^b (1) \theta dx = [-5/4 x^2/b]_0^b Fb 1/EJ + [x]_0^b \theta$$

$$= (-5/4 b) Fb 1/EJ + (b) \theta = -1/4 Fb^2/EJ$$

$$L_{FE}^{xo} = \int_0^b (-5/2 + 5/2 x/b) Fb 1/EJ dx + \int_0^b (-1) \theta dx = [-5/2 x + 5/4 x^2/b]_0^b Fb 1/EJ + [-x]_0^b \theta$$

$$= (-5/2 b + 5/4 b) Fb 1/EJ + (-b) \theta = -1/4 Fb^2/EJ$$

$$L_{FC}^{xo} = \int_0^b (-5/2 + 5x/b - 5/2 x^2/b^2) Fb 1/EJ dx = [-5/2 x + 5/2 x^2/b - 5/6 x^3/b^2]_0^b Fb 1/EJ$$

$$= (-5/2 b + 5/2 b - 5/6 b) Fb 1/EJ = -5/6 Fb^2/EJ$$

$$L_{CF}^{xo} = \int_0^b (-5/2 x^2/b^2) Fb 1/EJ dx = [-5/6 x^3/b^2]_0^b Fb 1/EJ$$

$$= (-5/6 b) Fb 1/EJ = -5/6 Fb^2/EJ$$

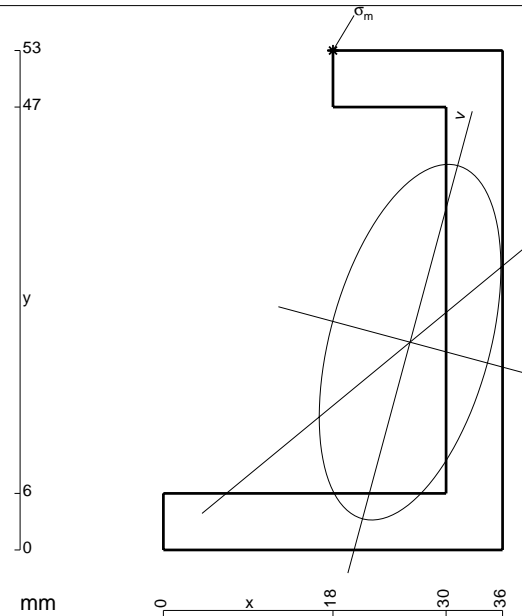

- A = 570. mm²
- J_x = 203061. mm⁴
- J_y = 52950. mm⁴
- J_{xy} = 43600. mm⁴
- J_u = 214806. mm⁴
- J_v = 41205. mm⁴
- α = arctg(2J_{xy}/(J_y-J_x))/2 = -.2631
- c = cos α = .9656
- s = sin α = -.2601
- x_g = 26.18 mm
- y_g = 22.05 mm
- N = -3050. N
- T_y = -2257. N
- M_x = 902800. Nmm
- x_m = 18. mm
- y_m = 53. mm
- u_m = -15.95 mm
- v_m = 27.76 mm
- σ_m = N/A - Mc_v/J_u - Ms_u/J_v = -208.9 N/mm²

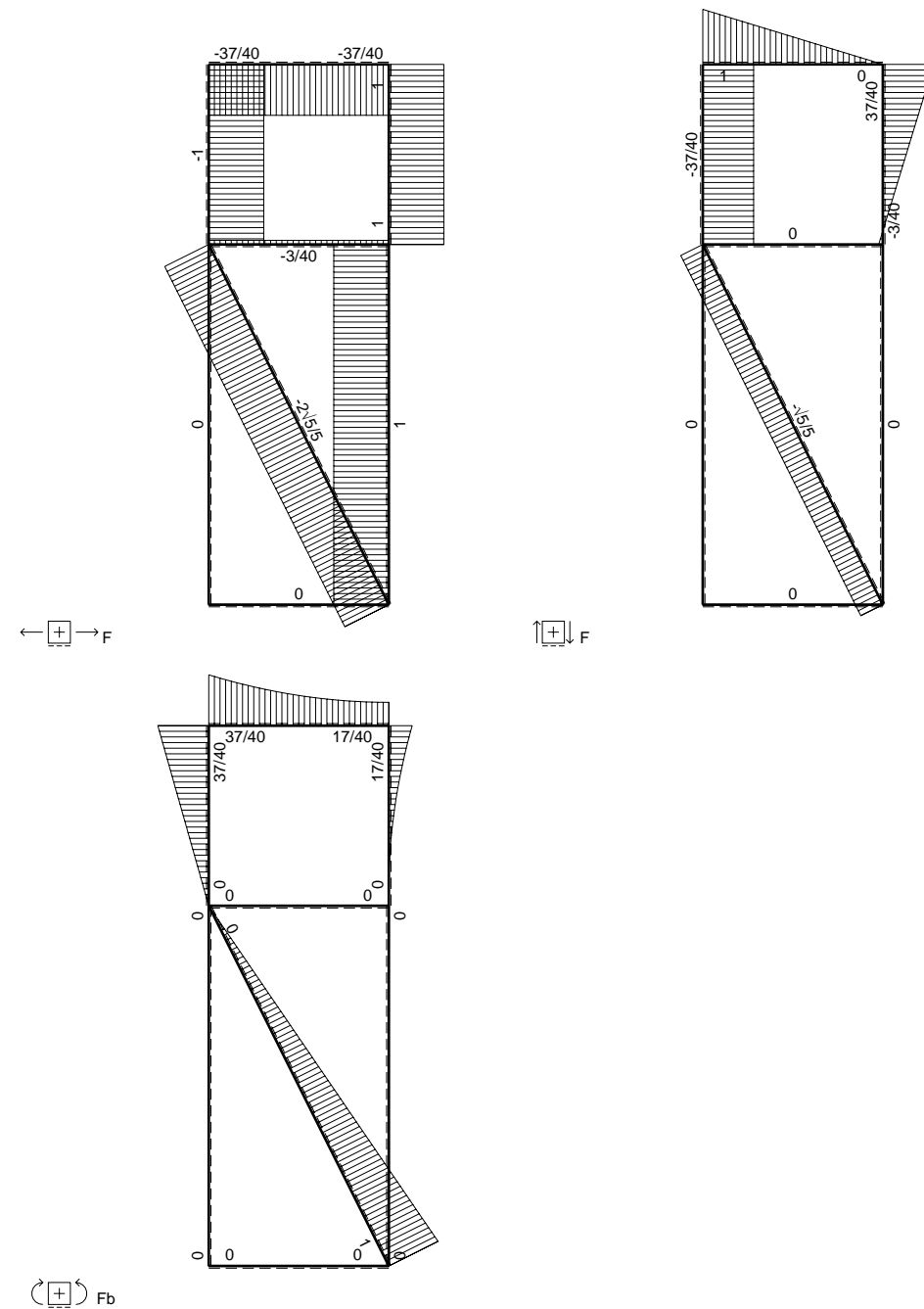
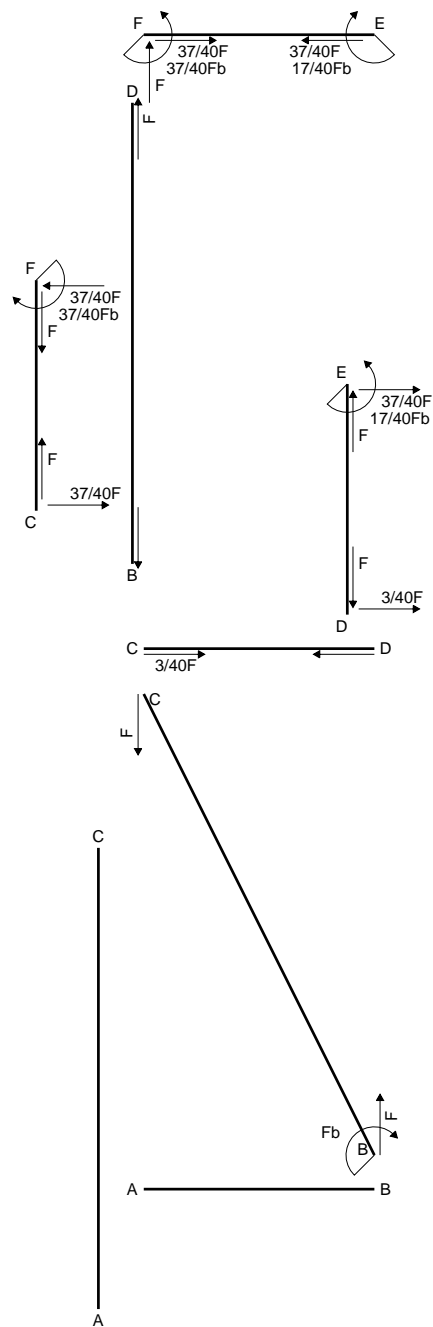

$$L_{DE}^{xx} = \int_0^b (x^2/b^2) 1/EJ dx = [1/3 x^3/b^2]_0^b 1/EJ$$

$$= (1/3 b) 1/EJ = 1/3 b/EJ$$

$$L_{ED}^{xx} = \int_0^b (1 - 2x/b + x^2/b^2) 1/EJ dx = [x - x^2/b + 1/3 x^3/b^2]_0^b 1/EJ$$

$$= (b - b + 1/3 b) 1/EJ = 1/3 b/EJ$$

$$L_{EF}^{xx} = \int_0^b (1) 1/EJ dx = [x]_0^b 1/EJ$$

$$= (b) 1/EJ = b/EJ$$

$$L_{FE}^{xx} = \int_0^b (1) 1/EJ dx = [x]_0^b 1/EJ$$

$$= (b) 1/EJ = b/EJ$$

$$L_{FC}^{xx} = \int_0^b (1 - 2x/b + x^2/b^2) 1/EJ dx = [x - x^2/b + 1/3 x^3/b^2]_0^b 1/EJ$$

$$= (b - b + 1/3 b) 1/EJ = 1/3 b/EJ$$

$$L_{CF}^{xx} = \int_0^b (x^2/b^2) 1/EJ dx = [1/3 x^3/b^2]_0^b 1/EJ$$

$$= (1/3 b) 1/EJ = 1/3 b/EJ$$

$$L_{DE}^{x_0} = \int_0^b (1/2 x^2/b^2 - 1/2 x^3/b^3) Fb 1/EJ dx = [1/6 x^3/b^2 - 1/8 x^4/b^3]_0^b Fb 1/EJ$$

$$= (1/6 b - 1/8 b) Fb 1/EJ = 1/24 Fb^2/EJ$$

$$L_{ED}^{x_0} = \int_0^b (1/2 x/b - x^2/b^2 + 1/2 x^3/b^3) Fb 1/EJ dx = [1/4 x^2/b - 1/3 x^3/b^2 + 1/8 x^4/b^3]_0^b Fb 1/EJ$$

$$= (1/4 b - 1/3 b + 1/8 b) Fb 1/EJ = 1/24 Fb^2/EJ$$

$$L_{EF}^{x_0} = \int_0^b (-1/2 x^2/b^2) Fb 1/EJ dx + \int_0^b (1) \theta dx = [-1/6 x^3/b^2]_0^b Fb 1/EJ + [x]_0^b \theta$$

$$= (-1/6 b) Fb 1/EJ + (b) \theta = 5/6 Fb^2/EJ$$

$$L_{FE}^{x_0} = \int_0^b (-1/2 + x/b - 1/2 x^2/b^2) Fb 1/EJ dx + \int_0^b (-1) \theta dx$$

$$= [-1/2 x + 1/2 x^2/b - 1/6 x^3/b^2]_0^b Fb 1/EJ + [-x]_0^b \theta$$

$$= (-1/2 b + 1/2 b - 1/6 b) Fb 1/EJ + (-b) \theta = 5/6 Fb^2/EJ$$

$$L_{FC}^{x_0} = \int_0^b (-1/2 + x/b - 1/2 x^2/b^2) Fb 1/EJ dx = [-1/2 x + 1/2 x^2/b - 1/6 x^3/b^2]_0^b Fb 1/EJ$$

$$= (-1/2 b + 1/2 b - 1/6 b) Fb 1/EJ = -1/6 Fb^2/EJ$$

$$L_{CF}^{x_0} = \int_0^b (-1/2 x^2/b^2) Fb 1/EJ dx = [-1/6 x^3/b^2]_0^b Fb 1/EJ$$

$$= (-1/6 b) Fb 1/EJ = -1/6 Fb^2/EJ$$

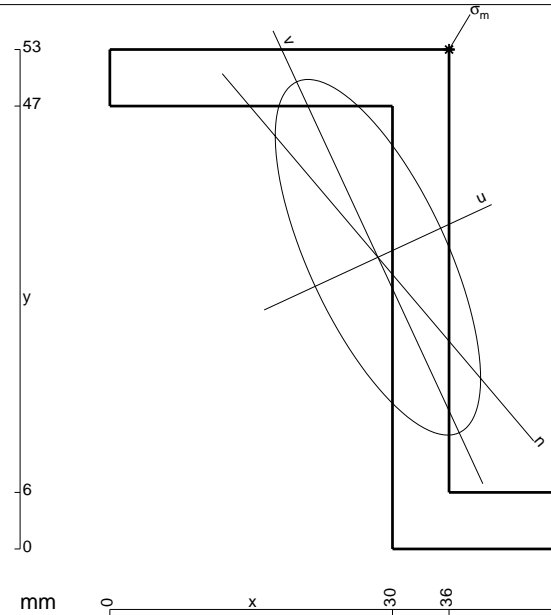

- A = 570. mm²
- J_x = 203061. mm⁴
- J_y = 67683. mm⁴
- J_{xy} = -79827. mm⁴
- J_u = 240034. mm⁴
- J_v = 30710. mm⁴
- α = arctg(2J_{xy}/(J_y-J_x))/2 = .4337
- c = cos α = .9074
- s = sin α = .4203
- x_g = 28.45 mm
- y_g = 30.95 mm
- N = -1547. N
- T_y = -773.7 N
- M_x = 761200. Nmm
- x_m = 36. mm
- y_m = 53. mm
- u_m = 16.11 mm
- v_m = 16.83 mm
- σ_m = N/A - Mcv/J_u - Msu/J_v = -219. N/mm²

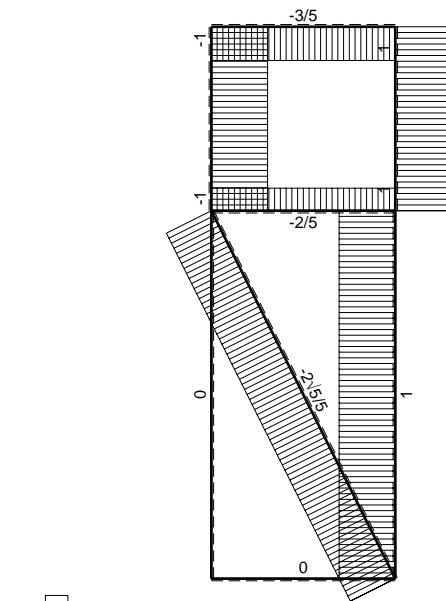
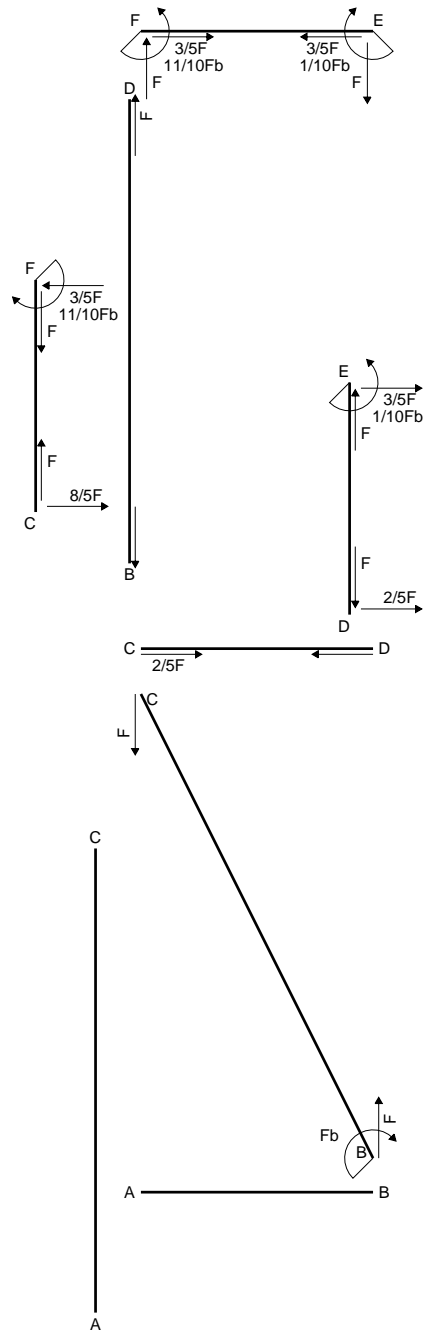

← ⊕ → F

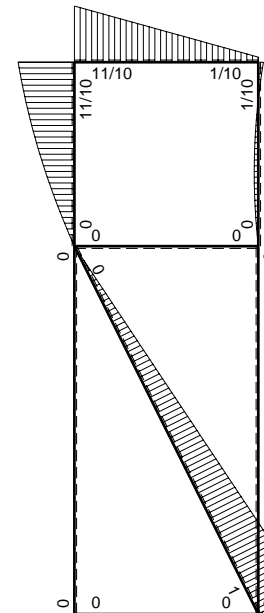

⊕ F_b

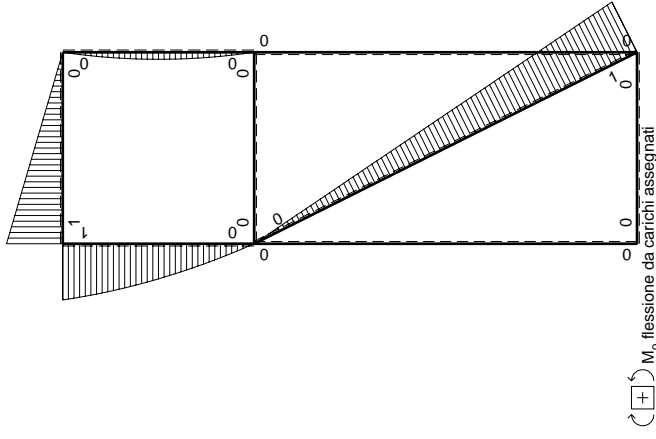
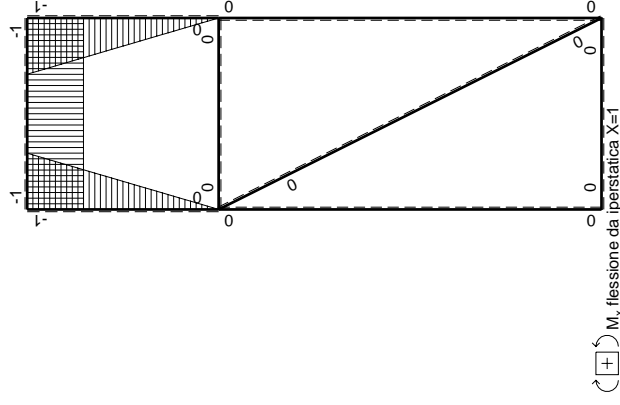
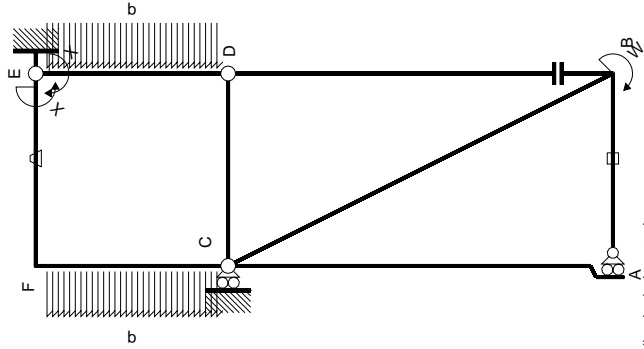

Quadro contributi PLV per iperstatica $X=W_{EF}$

\rightarrow	$M(x)$	$M_0(x)$	θ	$M_x M_0$	$M_x \theta$	$M_x M_x$	$\int M_x(M_0/EJ+\theta)dx$	$\int M_x M_x/EJ dx$
AB b	0	0	0	0	0	0	0+0	0
BA b	0	0	0	0	0	0	0	0
BC $\sqrt{5}b$	0	$Fb-\sqrt{5}/5Fx$	0	0	0	0	0	0
CA 2b	0	0	0	0	0	0	0+0	0
DB 2b	0	0	0	0	0	0	0+0	0
BD 2b	0	0	0	0	0	0	0	0
DE b	$-x/b$	$-1/2Fx+1/2qx^2$	0	$1/2Fx^2/b-1/2qx^3/b$	0	0	x^2/b^2	0
ED b	$1-x/b$	$1/2Fx-1/2qx^2$	0	$1/2Fx-Fx^2/b+1/2qx^3/b$	0	0	$1-2x/b+x^2/b^2$	$1/3xb/EJ$
CD b	0	0	0	0	0	0	0+0	0
DC b	0	0	0	0	0	0	0	0
EF b	-1	Fx	$-Fb/EJ$	-Fx	Fb/EJ	1	$(-1/2+1)Fb^2/EJ$	xb/EJ
FE b	1	$-Fb+Fx$	Fb/EJ	$-Fb+Fx$	Fb/EJ	1	$(-1/2+1)Fb^2/EJ$	xb/EJ
FC b	$-1+x/b$	$Fb-1/2Fx-1/2qx^2$	0	$-Fb+3/2Fx-1/2qx^3/b$	0	0	$1-2x/b+x^2/b^2$	$1/3xb/EJ$
CF b	x/b	$-3/2Fx+1/2qx^2$	0	$-3/2Fx^2/b+1/2qx^3/b$	0	0	x^2/b^2	$1/3xb/EJ$
totali								
iperstatica $X=W_{EF}$								

Sviluppi di calcolo iperstatica

$$L_{DE}^{xx} = \int_0^b (x^2/b^2) 1/EJ dx = [1/3 x^3/b^2]_0^b 1/EJ$$

$$= (1/3 b) 1/EJ = 1/3 b/EJ$$

$$L_{ED}^{xx} = \int_0^b (1 - 2x/b + x^2/b^2) 1/EJ dx = [x - x^2/b + 1/3 x^3/b^2]_0^b 1/EJ$$

$$= (b - b + 1/3 b) 1/EJ = 1/3 b/EJ$$

$$L_{EF}^{xx} = \int_0^b (1) 1/EJ dx = [x]_0^b 1/EJ$$

$$= (b) 1/EJ = b/EJ$$

$$L_{FE}^{xx} = \int_0^b (1) 1/EJ dx = [x]_0^b 1/EJ$$

$$= (b) 1/EJ = b/EJ$$

$$L_{FC}^{xx} = \int_0^b (1 - 2x/b + x^2/b^2) 1/EJ dx = [x - x^2/b + 1/3 x^3/b^2]_0^b 1/EJ$$

$$= (b - b + 1/3 b) 1/EJ = 1/3 b/EJ$$

$$L_{CF}^{xx} = \int_0^b (x^2/b^2) 1/EJ dx = [1/3 x^3/b^2]_0^b 1/EJ$$

$$= (1/3 b) 1/EJ = 1/3 b/EJ$$

$$L_{DE}^{xo} = \int_0^b (1/2 x^2/b^2 - 1/2 x^3/b^3) Fb 1/EJ dx = [1/6 x^3/b^2 - 1/8 x^4/b^3]_0^b Fb 1/EJ$$

$$= (1/6 b - 1/8 b) Fb 1/EJ = 1/24 Fb^2/EJ$$

$$L_{ED}^{xo} = \int_0^b (1/2 x/b - x^2/b^2 + 1/2 x^3/b^3) Fb 1/EJ dx = [1/4 x^2/b - 1/3 x^3/b^2 + 1/8 x^4/b^3]_0^b Fb 1/EJ$$

$$= (1/4 b - 1/3 b + 1/8 b) Fb 1/EJ = 1/24 Fb^2/EJ$$

$$L_{EF}^{xo} = \int_0^b (-x/b) Fb 1/EJ dx + \int_0^b (1) \theta dx = [-1/2 x^2/b]_0^b Fb 1/EJ + [x]_0^b \theta$$

$$= (-1/2 b) Fb 1/EJ + (b) \theta = 1/2 Fb^2/EJ$$

$$L_{FE}^{xo} = \int_0^b (-1 + x/b) Fb 1/EJ dx + \int_0^b (-1) \theta dx = [-x + 1/2 x^2/b]_0^b Fb 1/EJ + [-x]_0^b \theta$$

$$= (-b + 1/2 b) Fb 1/EJ + (-b) \theta = 1/2 Fb^2/EJ$$

$$L_{FC}^{xo} = \int_0^b (-1 + 3/2 x/b - 1/2 x^3/b^3) Fb 1/EJ dx = [-x + 3/4 x^2/b - 1/8 x^4/b^3]_0^b Fb 1/EJ$$

$$= (-b + 3/4 b - 1/8 b) Fb 1/EJ = -3/8 Fb^2/EJ$$

$$L_{CF}^{xo} = \int_0^b (-3/2 x^2/b^2 + 1/2 x^3/b^3) Fb 1/EJ dx = [-1/2 x^3/b^2 + 1/8 x^4/b^3]_0^b Fb 1/EJ$$

$$= (-1/2 b + 1/8 b) Fb 1/EJ = -3/8 Fb^2/EJ$$

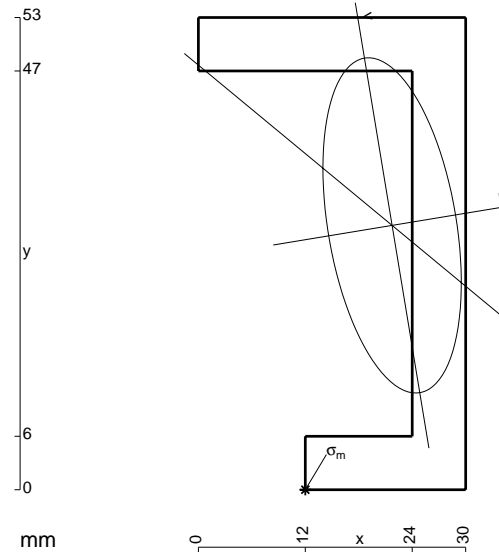

- A = 534. mm²
- J_x = 189011. mm⁴
- J_y = 32196. mm⁴
- J_{xy} = -26635. mm⁴
- J_u = 193412. mm⁴
- J_v = 27796. mm⁴
- α = arctg(2J_{xy}/(J_y-J_x))/2 = .1637
- c = cos α = .9866
- s = sin α = .1630
- x_g = 21.74 mm
- y_g = 29.67 mm
- N = -1164. N
- T_y = 1940. N
- M_x = 1024320. Nmm
- x_m = 12. mm
- u_m = -14.45 mm
- v_m = -27.68 mm
- σ_m = N/A - Mcv/J_u - Msu/J_v = 229.3 N/mm²

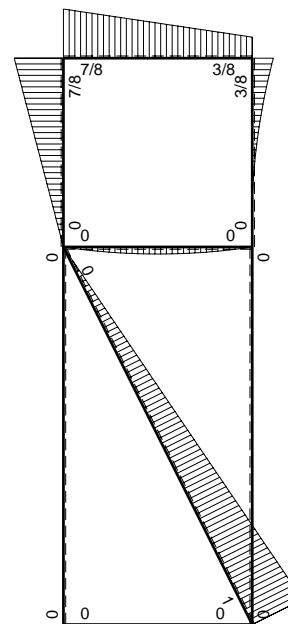
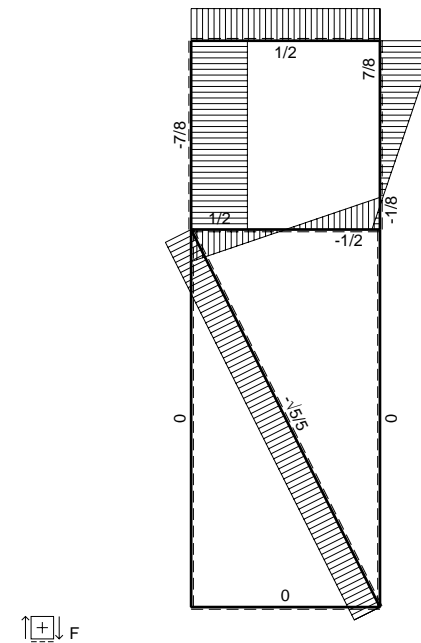
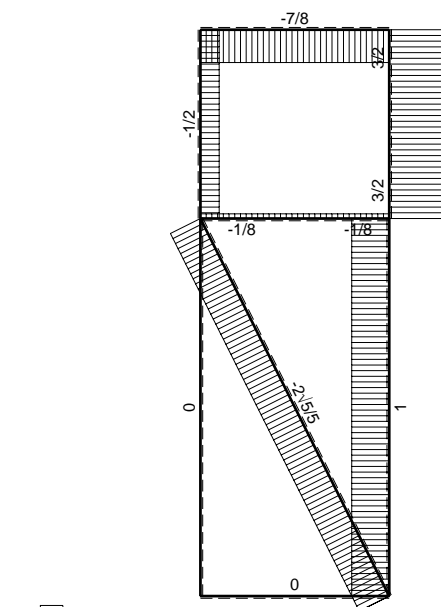
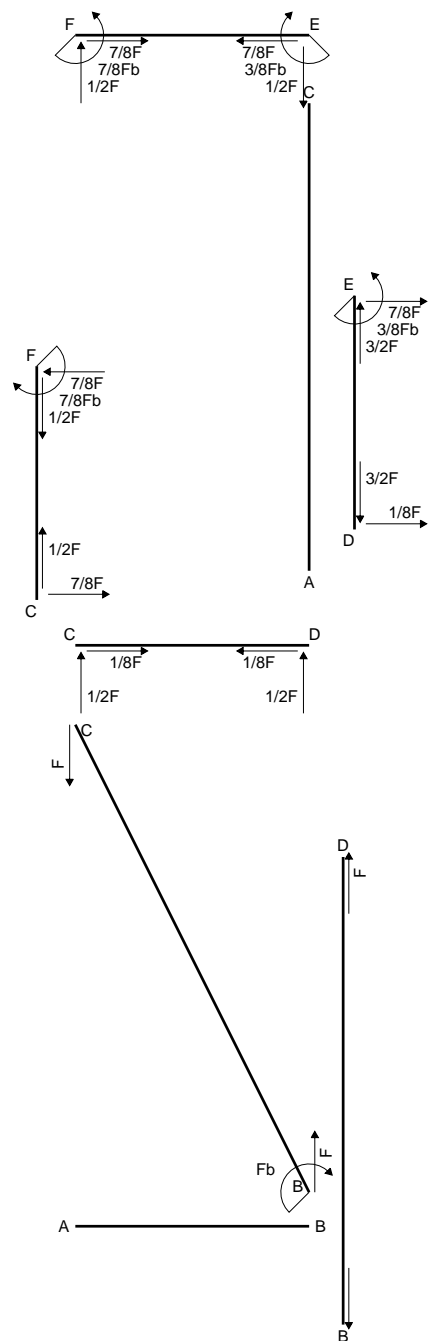

$\curvearrowright \boxed{+} \curvearrowleft Fb$

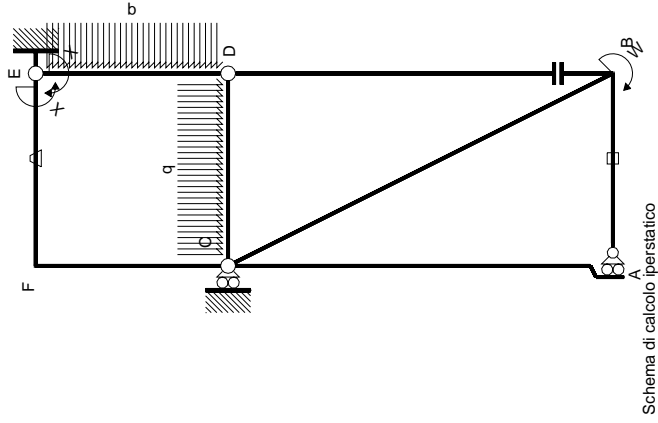

M_0 flessione da carichi assegnati

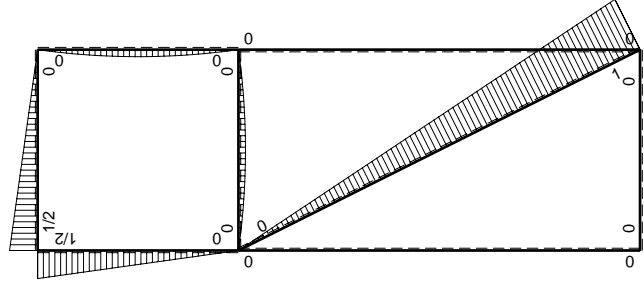

Quadro contributi PLV per iperstatica $X=W_{EF}$

\leftarrow	$M^x(x)$	$M^0(x)$	θ	$M^x M_0$	$M^x \theta$	$M^x M_x$	$\int M^x (M_0/EJ + \theta) dx$	$\int M^x M_x/EJ dx$
AB b	0	0	0	0	0	0	0+0	0
BA b	0	0	0	0	0	0	0	0
BC $\sqrt{5}b$	0	$Fb\sqrt{5}/5Fx$	0	0	0	0	0+0	0
CA 2b	0	0	0	0	0	0	0+0	0
DB 2b	0	0	0	0	0	0	0+0	0
BD 2b	0	0	0	0	0	0	0+0	0
DE b	$-x/b$	$-1/2Fx+1/2qx^2$	0	$1/2Fx^2/b-1/2qx^3/b$	0	0	x^2/b^2	$1/3Xb/EJ$
ED b	$1-x/b$	$1/2Fx-1/2qx^2$	0	$1/2Fx-Fx^2/b+1/2qx^3/b$	0	0	$1-2x/b+x^2/b^2$	$1/3Xb/EJ$
CD b	0	$1/2Fx-1/2qx^2$	0	0	0	0	0	0
DC b	0	$-1/2Fx+1/2qx^2$	0	0	0	0	0+0	0
EF b	-1	$1/2Fx$	$-Fb/EJ$	$-1/2Fx$	Fb/EJ	1	$(-1/4+1)Fb^2/EJ$	Xb/EJ
FE b	1	$-1/2Fb+1/2Fx$	Fb/EJ	$-1/2Fb+1/2Fx$	Fb/EJ	1	$(-1/4+1)Fb^2/EJ$	Xb/EJ
FC b	$-1+x/b$	$1/2Fb-1/2Fx$	0	$-1/2Fb+Fx-1/2Fx^2/b$	0	0	$1-2x/b+x^2/b^2$	$1/3Xb/EJ$
CF b	x/b	$-1/2Fx$	0	$-1/2Fx^2/b$	0	0	x^2/b^2	$1/3Xb/EJ$
totali							$5/8Fb^2/EJ$	$5/3Xb/EJ$
								$-3/8Fb$

Sviluppi di calcolo iperstatica

M_x flessione da iperstatica $X=1$

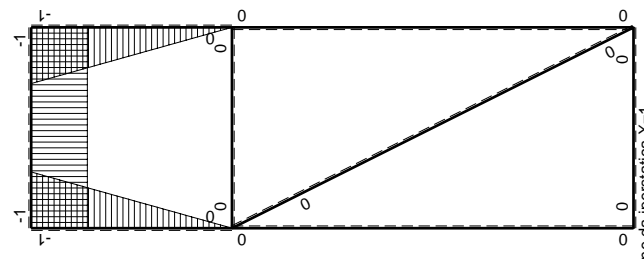

$$L_{DE}^{xx} = \int_0^b (x^2/b^2) 1/EJ dx = [1/3 x^3/b^2]_0^b 1/EJ$$

$$= (1/3 b) 1/EJ = 1/3 b/EJ$$

$$L_{ED}^{xx} = \int_0^b (1 - 2x/b + x^2/b^2) 1/EJ dx = [x - x^2/b + 1/3 x^3/b^2]_0^b 1/EJ$$

$$= (b - b + 1/3 b) 1/EJ = 1/3 b/EJ$$

$$L_{EF}^{xx} = \int_0^b (1) 1/EJ dx = [x]_0^b 1/EJ$$

$$= (b) 1/EJ = b/EJ$$

$$L_{FE}^{xx} = \int_0^b (1) 1/EJ dx = [x]_0^b 1/EJ$$

$$= (b) 1/EJ = b/EJ$$

$$L_{FC}^{xx} = \int_0^b (1 - 2x/b + x^2/b^2) 1/EJ dx = [x - x^2/b + 1/3 x^3/b^2]_0^b 1/EJ$$

$$= (b - b + 1/3 b) 1/EJ = 1/3 b/EJ$$

$$L_{CF}^{xx} = \int_0^b (x^2/b^2) 1/EJ dx = [1/3 x^3/b^2]_0^b 1/EJ$$

$$= (1/3 b) 1/EJ = 1/3 b/EJ$$

$$L_{DE}^{xo} = \int_0^b (1/2 x^2/b^2 - 1/2 x^3/b^3) Fb 1/EJ dx = [1/6 x^3/b^2 - 1/8 x^4/b^3]_0^b Fb 1/EJ$$

$$= (1/6 b - 1/8 b) Fb 1/EJ = 1/24 Fb^2/EJ$$

$$L_{ED}^{xo} = \int_0^b (1/2 x/b - x^2/b^2 + 1/2 x^3/b^3) Fb 1/EJ dx = [1/4 x^2/b - 1/3 x^3/b^2 + 1/8 x^4/b^3]_0^b Fb 1/EJ$$

$$= (1/4 b - 1/3 b + 1/8 b) Fb 1/EJ = 1/24 Fb^2/EJ$$

$$L_{EF}^{xo} = \int_0^b (-1/2 x/b) Fb 1/EJ dx + \int_0^b (1) \theta dx = [-1/4 x^2/b]_0^b Fb 1/EJ + [x]_0^b \theta$$

$$= (-1/4 b) Fb 1/EJ + (b) \theta = 3/4 Fb^2/EJ$$

$$L_{FE}^{xo} = \int_0^b (-1/2 + 1/2 x/b) Fb 1/EJ dx + \int_0^b (-1) \theta dx = [-1/2 x + 1/4 x^2/b]_0^b Fb 1/EJ + [-x]_0^b \theta$$

$$= (-1/2 b + 1/4 b) Fb 1/EJ + (-b) \theta = 3/4 Fb^2/EJ$$

$$L_{FC}^{xo} = \int_0^b (-1/2 + x/b - 1/2 x^2/b^2) Fb 1/EJ dx = [-1/2 x + 1/2 x^2/b - 1/6 x^3/b^2]_0^b Fb 1/EJ$$

$$= (-1/2 b + 1/2 b - 1/6 b) Fb 1/EJ = -1/6 Fb^2/EJ$$

$$L_{CF}^{xo} = \int_0^b (-1/2 x^2/b^2) Fb 1/EJ dx = [-1/6 x^3/b^2]_0^b Fb 1/EJ$$

$$= (-1/6 b) Fb 1/EJ = -1/6 Fb^2/EJ$$

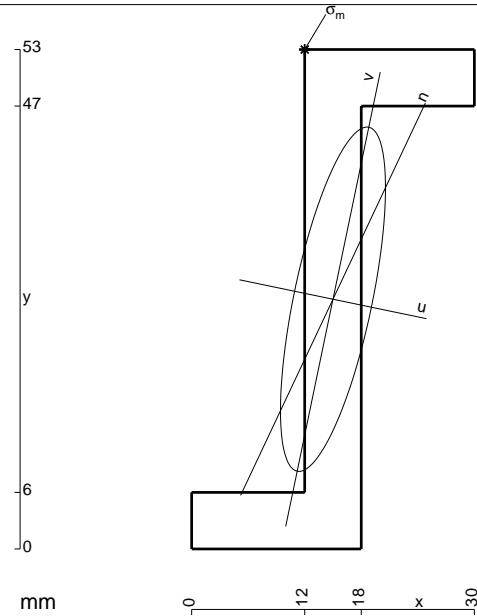

- A = 462. mm²
- J_x = 154395. mm⁴
- J_y = 14346. mm⁴
- J_{xy} = 30456. mm⁴
- J_u = 160731. mm⁴
- J_v = 8010. mm⁴
- α = arctg(2J_{xy}/(J_y-J_x))/2 = -.2051
- c = cos α = .9790
- s = sin α = -.2037
- x_g = 15. mm
- y_g = 26.5 mm
- N = -1136. N
- T_y = -568. N
- M_x = 647700. Nmm
- x_m = 12. mm
- y_m = 53. mm
- u_m = -8.335 mm
- v_m = 25.33 mm
- σ_m = N/A - Mc_v/J_u - Ms_u/J_v = -239.7 N/mm²

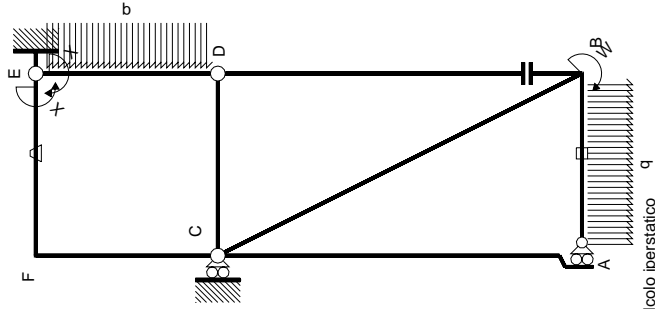

Schema di calcolo iperstatico

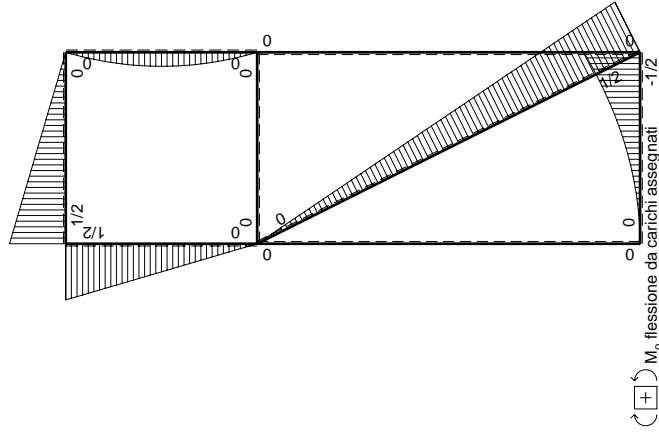

M_0 flessione da carichi assegnati

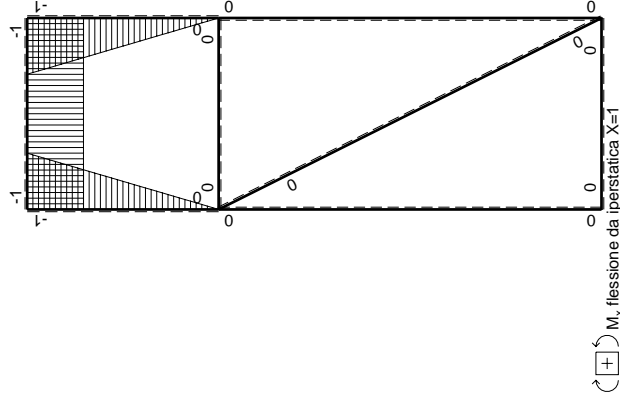

M_x flessione da iperstatica $X=1$

Quadro contribuiti PLV per iperstatica $X=W_{EF}$

\rightarrow	$M_x(x)$	$M_0(x)$	θ	$M_x M_0$	$M_x \theta$	$M_x M_x$	$\int M_x(M_0/EJ+\theta)dx$	$\int M_x M_x/EJ dx$
AB b	0	$-1/2qx^2$	0	0	0	0	0+0	0
BA b	0	$1/2Fb-Fx+1/2qx^2$	0	0	0	0	0	0
BC $\sqrt{5}b$	0	$1/2Fb-\sqrt{5}/10Fx$	0	0	0	0	0+0	0
CA 2b	0	0	0	0	0	0	0+0	0
DB 2b	0	0	0	0	0	0	0+0	0
BD 2b	0	0	0	0	0	0	0+0	0
DE b	$-x/b$	$-1/2Fx+1/2qx^2$	0	$1/2F^2x^2/b-1/2qx^3/b$	0	0	x^2/b^2	0
ED b	$1-x/b$	$1/2Fx-1/2qx^2$	0	$1/2Fx-Fx^2/b+1/2qx^3/b$	0	0	$1-2x/b+x^2/b^2$	$1/3xb/EJ$
CD b	0	0	0	0	0	0	0+0	0
DC b	0	0	0	0	0	0	0+0	0
EF b	-1	$1/2Fx$	$-Fb/EJ$	$-1/2Fx$	Fb/EJ	1	$(-1/4+1)Fb^2/EJ$	xb/EJ
FE b	1	$-1/2Fb+1/2Fx$	Fb/EJ	$-1/2Fb+1/2Fx$	Fb/EJ	1	$(-1/4+1)Fb^2/EJ$	xb/EJ
FC b	$-1+x/b$	$1/2Fb-1/2Fx$	0	$-1/2Fb+Fx-1/2Fx^2/b$	0	0	$1-2x/b+x^2/b^2$	$1/3xb/EJ$
CF b	x/b	$-1/2Fx$	0	$-1/2Fx^2/b$	0	0	x^2/b^2	$1/3xb/EJ$
totali								$5/8Fb^2/EJ$
								$-3/8Fb$

Sviluppi di calcolo iperstatica

$$L_{DE}^{xx} = \int_0^b (x^2/b^2) 1/EJ dx = [1/3 x^3/b^2]_0^b 1/EJ$$

$$= (1/3 b) 1/EJ = 1/3 b/EJ$$

$$L_{ED}^{xx} = \int_0^b (1 - 2x/b + x^2/b^2) 1/EJ dx = [x - x^2/b + 1/3 x^3/b^2]_0^b 1/EJ$$

$$= (b - b + 1/3 b) 1/EJ = 1/3 b/EJ$$

$$L_{EF}^{xx} = \int_0^b (1) 1/EJ dx = [x]_0^b 1/EJ$$

$$= (b) 1/EJ = b/EJ$$

$$L_{FE}^{xx} = \int_0^b (1) 1/EJ dx = [x]_0^b 1/EJ$$

$$= (b) 1/EJ = b/EJ$$

$$L_{FC}^{xx} = \int_0^b (1 - 2x/b + x^2/b^2) 1/EJ dx = [x - x^2/b + 1/3 x^3/b^2]_0^b 1/EJ$$

$$= (b - b + 1/3 b) 1/EJ = 1/3 b/EJ$$

$$L_{CF}^{xx} = \int_0^b (x^2/b^2) 1/EJ dx = [1/3 x^3/b^2]_0^b 1/EJ$$

$$= (1/3 b) 1/EJ = 1/3 b/EJ$$

$$L_{DE}^{xo} = \int_0^b (1/2 x^2/b^2 - 1/2 x^3/b^3) Fb 1/EJ dx = [1/6 x^3/b^2 - 1/8 x^4/b^3]_0^b Fb 1/EJ$$

$$= (1/6 b - 1/8 b) Fb 1/EJ = 1/24 Fb^2/EJ$$

$$L_{ED}^{xo} = \int_0^b (1/2 x/b - x^2/b^2 + 1/2 x^3/b^3) Fb 1/EJ dx = [1/4 x^2/b - 1/3 x^3/b^2 + 1/8 x^4/b^3]_0^b Fb 1/EJ$$

$$= (1/4 b - 1/3 b + 1/8 b) Fb 1/EJ = 1/24 Fb^2/EJ$$

$$L_{EF}^{xo} = \int_0^b (-1/2 x/b) Fb 1/EJ dx + \int_0^b (1) \theta dx = [-1/4 x^2/b]_0^b Fb 1/EJ + [x]_0^b \theta$$

$$= (-1/4 b) Fb 1/EJ + (b) \theta = 3/4 Fb^2/EJ$$

$$L_{FE}^{xo} = \int_0^b (-1/2 + 1/2 x/b) Fb 1/EJ dx + \int_0^b (-1) \theta dx = [-1/2 x + 1/4 x^2/b]_0^b Fb 1/EJ + [-x]_0^b \theta$$

$$= (-1/2 b + 1/4 b) Fb 1/EJ + (-b) \theta = 3/4 Fb^2/EJ$$

$$L_{FC}^{xo} = \int_0^b (-1/2 + x/b - 1/2 x^2/b^2) Fb 1/EJ dx = [-1/2 x + 1/2 x^2/b - 1/6 x^3/b^2]_0^b Fb 1/EJ$$

$$= (-1/2 b + 1/2 b - 1/6 b) Fb 1/EJ = -1/6 Fb^2/EJ$$

$$L_{CF}^{xo} = \int_0^b (-1/2 x^2/b^2) Fb 1/EJ dx = [-1/6 x^3/b^2]_0^b Fb 1/EJ$$

$$= (-1/6 b) Fb 1/EJ = -1/6 Fb^2/EJ$$

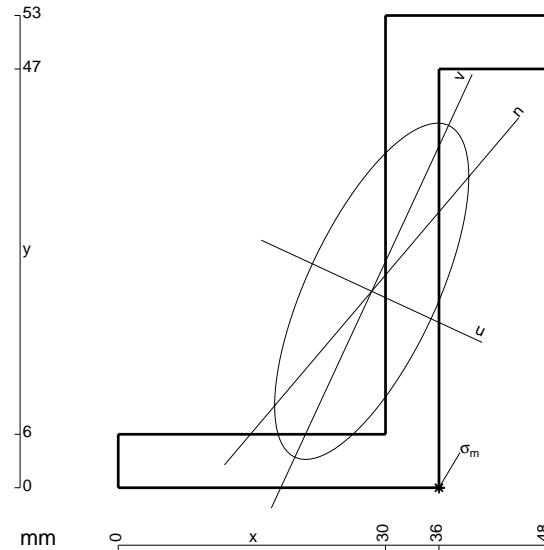

- A = 570. mm²
- J_x = 203061. mm⁴
- J_y = 67683. mm⁴
- J_{xy} = 79827. mm⁴
- J_u = 240034. mm⁴
- J_v = 30710. mm⁴
- α = arctg(2J_{xy}/(J_y-J_x))/2 = -.4337
- c = cosα = .9074
- s = sinα = -.4203
- x_g = 28.45 mm
- y_g = 22.05 mm
- N = -735. N
- T_y = -1286. N
- M_x = 707438. Nmm
- x_m = 36. mm
- u_m = 16.11 mm
- v_m = -16.83 mm
- σ_m = N/A-Mcv/J_u-Msv/J_v = 199.7 N/mm²

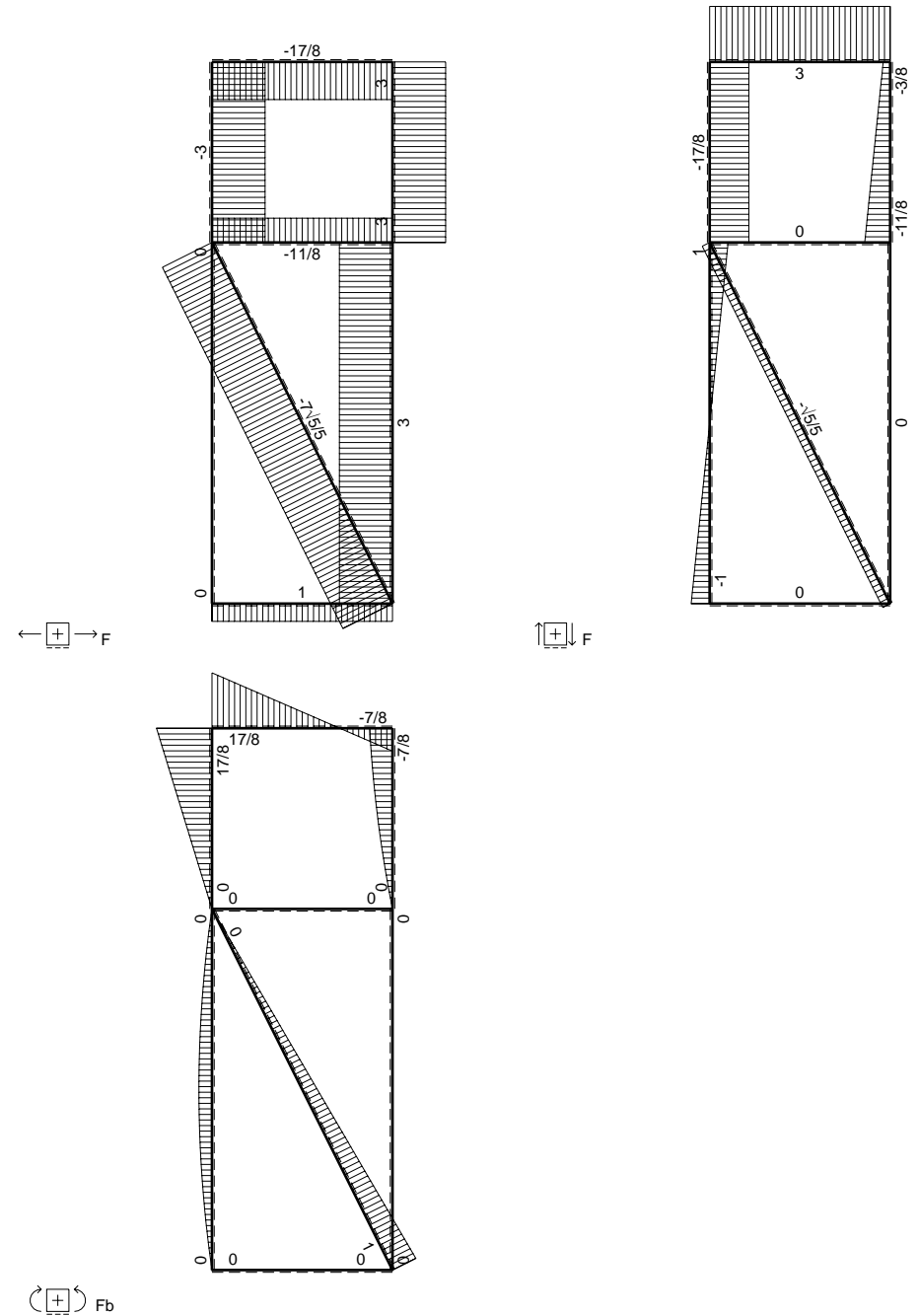
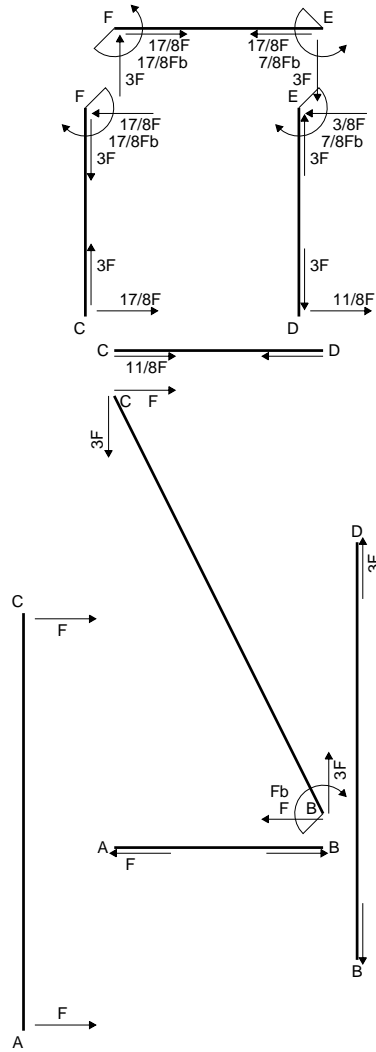

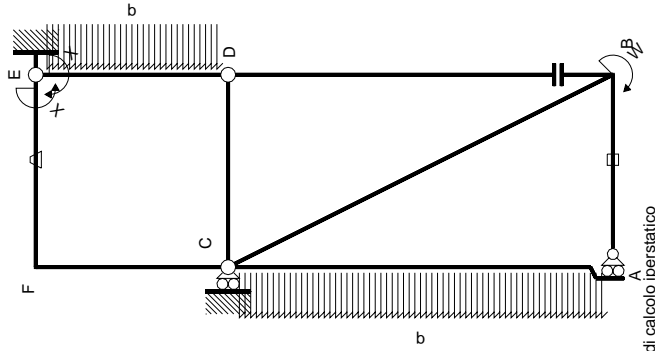

M_0 flessione da carichi assegnati

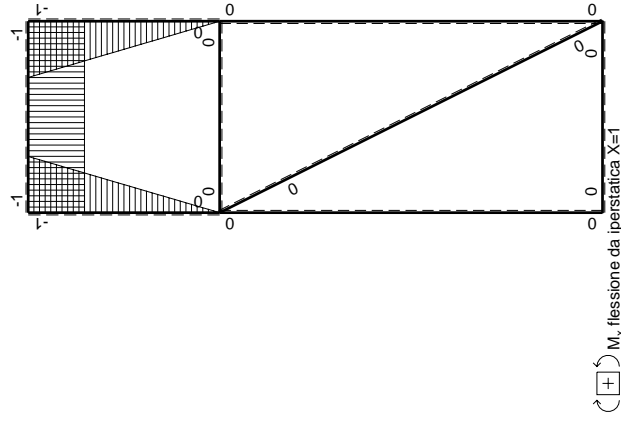

Quadro contributi PLV per iperstatica $X=W_{EF}$

\leftarrow	$M^x(x)$	$M^0(x)$	θ	$M^x M_0$	$M^x \theta$	$M^x M_x$	$\int M^x (M_0/EJ + \theta) dx$	$\int M^x M_x / EJ dx$
AB b	0	0	0	0	0	0	0	0
BA b	0	0	0	0	0	0	0	0
BC $\sqrt{5}b$	0	$Fb - \sqrt{5}/5Fx$	0	0	0	0	0	0
AC 2b	0	$-Fx + 1/2qx^2$	0	0	0	0	0	0
CA 2b	0	$Fx - 1/2qx^2$	0	0	0	0	0	0
DB 2b	0	0	0	0	0	0	0	0
BD 2b	0	0	0	0	0	0	0	0
DE b	$-x/b$	$-1/2Fx + 1/2qx^2$	0	$1/2Fx^2/b - 1/2qx^3/b$	0	x^2/b^2	$(1/24+0)Fb^2/EJ$	$1/3Xb/EJ$
ED b	$1-x/b$	$1/2Fx - 1/2qx^2$	0	$1/2Fx - Fx^2/b + 1/2qx^3/b$	0	$1-2x/b+x^2/b^2$	$(1/24+0)Fb^2/EJ$	$1/3Xb/EJ$
CD b	0	0	0	0	0	0	0	0
DC b	0	0	0	0	0	0	0	0
EF b	-1	$3Fx$	$-Fb/EJ$	$-3Fx$	Fb/EJ	1	$(-3/2+1)Fb^2/EJ$	Xb/EJ
FE b	1	$-3Fb+3Fx$	Fb/EJ	$-3Fb+3Fx$	Fb/EJ	1	$(-3/2+1)Fb^2/EJ$	Xb/EJ
FC b	$-1+x/b$	$3Fb-3Fx$	0	$-3Fb+6Fx-3Fx^2/b$	0	$1-2x/b+x^2/b^2$	$(-1+0)Fb^2/EJ$	$1/3Xb/EJ$
CF b	x/b	$-3Fx$	0	$-3Fx^2/b$	0	x^2/b^2	$(-1+0)Fb^2/EJ$	$1/3Xb/EJ$
totali							$-35/24Fb^2/EJ$	$5/3Xb/EJ$
							$7/8Fb$	

Sviluppi di calcolo iperstatica

$$L_{DE}^{xx} = \int_0^b (x^2/b^2) 1/EJ dx = [1/3 x^3/b^2]_0^b 1/EJ$$

$$= (1/3 b) 1/EJ = 1/3 b/EJ$$

$$L_{ED}^{xx} = \int_0^b (1 - 2x/b + x^2/b^2) 1/EJ dx = [x - x^2/b + 1/3 x^3/b^2]_0^b 1/EJ$$

$$= (b - b + 1/3 b) 1/EJ = 1/3 b/EJ$$

$$L_{EF}^{xx} = \int_0^b (1) 1/EJ dx = [x]_0^b 1/EJ$$

$$= (b) 1/EJ = b/EJ$$

$$L_{FE}^{xx} = \int_0^b (1) 1/EJ dx = [x]_0^b 1/EJ$$

$$= (b) 1/EJ = b/EJ$$

$$L_{FC}^{xx} = \int_0^b (1 - 2x/b + x^2/b^2) 1/EJ dx = [x - x^2/b + 1/3 x^3/b^2]_0^b 1/EJ$$

$$= (b - b + 1/3 b) 1/EJ = 1/3 b/EJ$$

$$L_{CF}^{xx} = \int_0^b (x^2/b^2) 1/EJ dx = [1/3 x^3/b^2]_0^b 1/EJ$$

$$= (1/3 b) 1/EJ = 1/3 b/EJ$$

$$L_{DE}^{xo} = \int_0^b (1/2 x^2/b^2 - 1/2 x^3/b^3) Fb 1/EJ dx = [1/6 x^3/b^2 - 1/8 x^4/b^3]_0^b Fb 1/EJ$$

$$= (1/6 b - 1/8 b) Fb 1/EJ = 1/24 Fb^2/EJ$$

$$L_{ED}^{xo} = \int_0^b (1/2 x/b - x^2/b^2 + 1/2 x^3/b^3) Fb 1/EJ dx = [1/4 x^2/b - 1/3 x^3/b^2 + 1/8 x^4/b^3]_0^b Fb 1/EJ$$

$$= (1/4 b - 1/3 b + 1/8 b) Fb 1/EJ = 1/24 Fb^2/EJ$$

$$L_{EF}^{xo} = \int_0^b (-3x/b) Fb 1/EJ dx + \int_0^b (1) \theta dx = [-3/2 x^2/b]_0^b Fb 1/EJ + [x]_0^b \theta$$

$$= (-3/2 b) Fb 1/EJ + (b) \theta = -1/2 Fb^2/EJ$$

$$L_{FE}^{xo} = \int_0^b (-3 + 3x/b) Fb 1/EJ dx + \int_0^b (-1) \theta dx = [-3x + 3/2 x^2/b]_0^b Fb 1/EJ + [-x]_0^b \theta$$

$$= (-3b + 3/2 b) Fb 1/EJ + (-b) \theta = -1/2 Fb^2/EJ$$

$$L_{FC}^{xo} = \int_0^b (-3 + 6x/b - 3x^2/b^2) Fb 1/EJ dx = [-3x + 3x^2/b - x^3/b^2]_0^b Fb 1/EJ$$

$$= (-3b + 3b - b) Fb 1/EJ = - Fb^2/EJ$$

$$L_{CF}^{xo} = \int_0^b (-3x^2/b^2) Fb 1/EJ dx = [-x^3/b^2]_0^b Fb 1/EJ$$

$$= (-b) Fb 1/EJ = - Fb^2/EJ$$

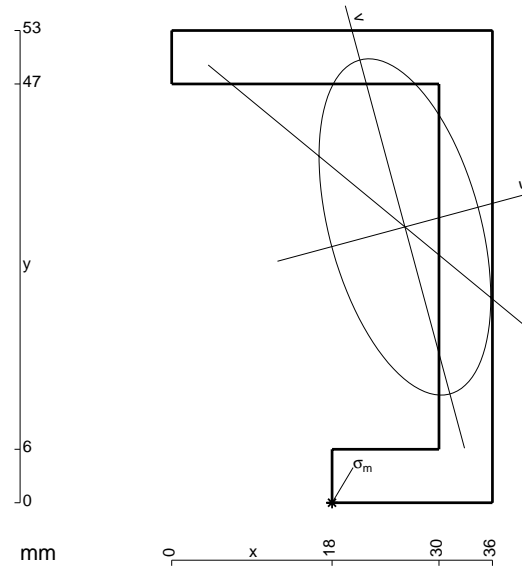

- A = 570. mm²
- J_x = 203061. mm⁴
- J_y = 52950. mm⁴
- J_{xy} = -43600. mm⁴
- J_u = 214806. mm⁴
- J_v = 41205. mm⁴
- α = arctg(2J_{xy}/(J_y-J_x))/2 = .2631
- c = cos α = .9656
- s = sin α = .2601
- x_g = 26.18 mm
- y_g = 30.95 mm
- N = -1594. N
- T_y = 2250. N
- M_x = 940313. Nmm
- x_m = 18. mm
- u_m = -15.95 mm
- v_m = -27.76 mm
- σ_m = N/A - Mc_v/J_u - Ms_u/J_v = 209.2 N/mm²

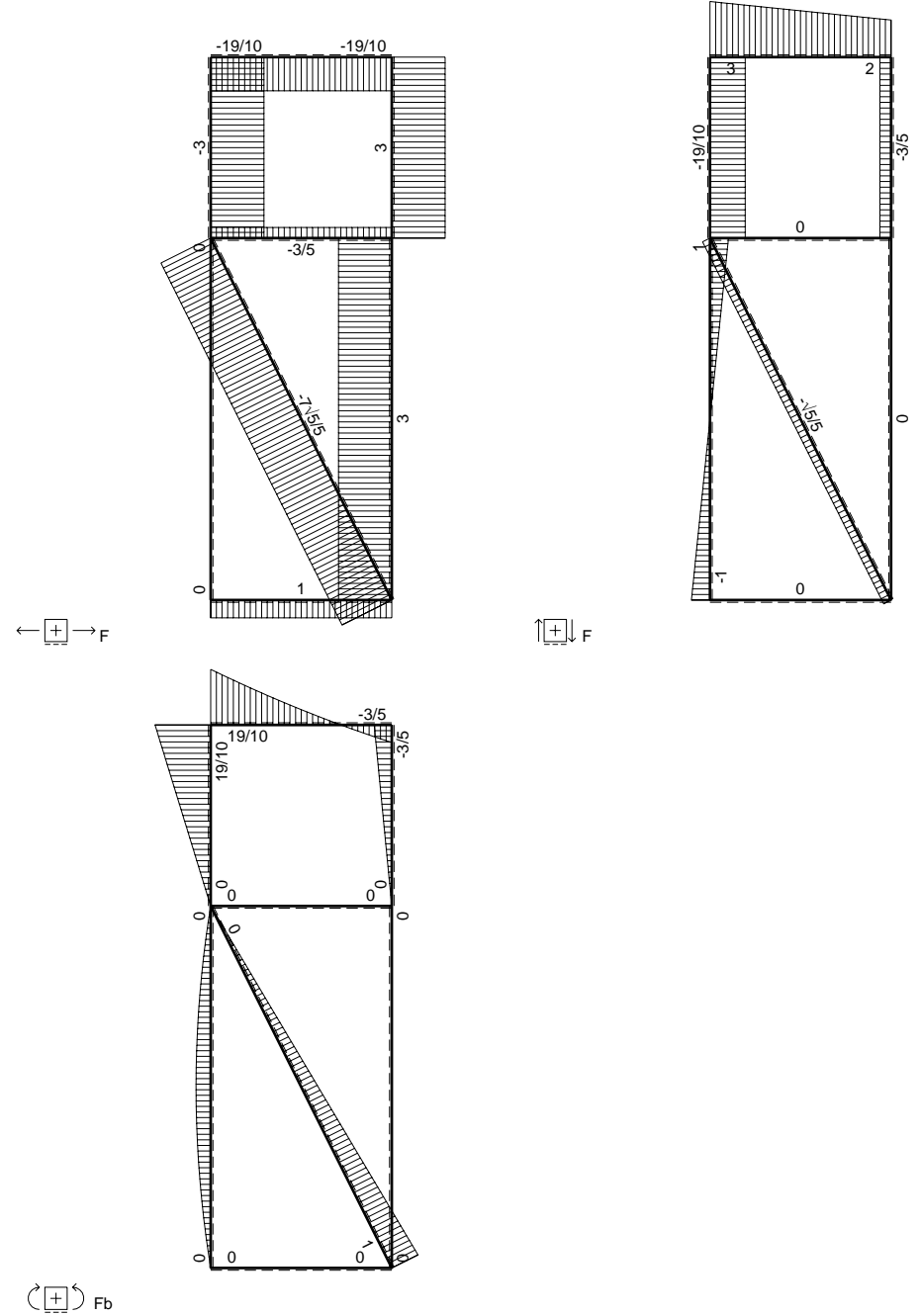
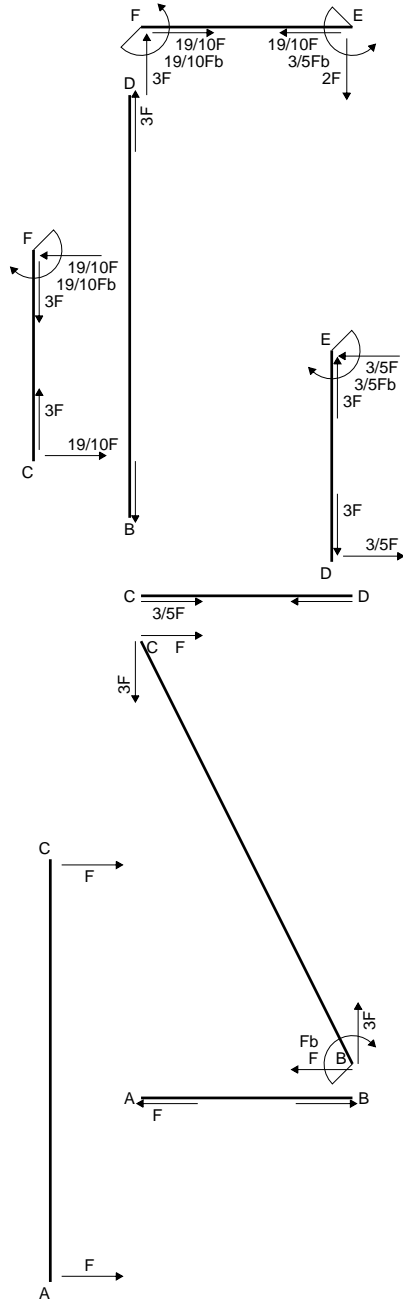

$$L_{DE}^{xx} = \int_0^b (x^2/b^2) 1/EJ dx = [1/3 x^3/b^2]_0^b 1/EJ$$

$$= (1/3 b) 1/EJ = 1/3 b/EJ$$

$$L_{ED}^{xx} = \int_0^b (1 - 2x/b + x^2/b^2) 1/EJ dx = [x - x^2/b + 1/3 x^3/b^2]_0^b 1/EJ$$

$$= (b - b + 1/3 b) 1/EJ = 1/3 b/EJ$$

$$L_{EF}^{xx} = \int_0^b (1) 1/EJ dx = [x]_0^b 1/EJ$$

$$= (b) 1/EJ = b/EJ$$

$$L_{FE}^{xx} = \int_0^b (1) 1/EJ dx = [x]_0^b 1/EJ$$

$$= (b) 1/EJ = b/EJ$$

$$L_{FC}^{xx} = \int_0^b (1 - 2x/b + x^2/b^2) 1/EJ dx = [x - x^2/b + 1/3 x^3/b^2]_0^b 1/EJ$$

$$= (b - b + 1/3 b) 1/EJ = 1/3 b/EJ$$

$$L_{CF}^{xx} = \int_0^b (x^2/b^2) 1/EJ dx = [1/3 x^3/b^2]_0^b 1/EJ$$

$$= (1/3 b) 1/EJ = 1/3 b/EJ$$

$$L_{EF}^{x\theta} = \int_0^b (-2x/b - 1/2 x^2/b^2) Fb 1/EJ dx + \int_0^b (1) \theta dx = [-x^2/b - 1/6 x^3/b^2]_0^b Fb 1/EJ + [x]_0^b \theta$$

$$= (-b - 1/6 b) Fb 1/EJ + (b) \theta = -1/6 Fb^2/EJ$$

$$L_{FE}^{x\theta} = \int_0^b (-5/2 + 3x/b - 1/2 x^2/b^2) Fb 1/EJ dx + \int_0^b (-1) \theta dx$$

$$= [-5/2 x + 3/2 x^2/b - 1/6 x^3/b^2]_0^b Fb 1/EJ + [-x]_0^b \theta$$

$$= (-5/2 b + 3/2 b - 1/6 b) Fb 1/EJ + (-b) \theta = -1/6 Fb^2/EJ$$

$$L_{FC}^{x\theta} = \int_0^b (-5/2 + 5x/b - 5/2 x^2/b^2) Fb 1/EJ dx = [-5/2 x + 5/2 x^2/b - 5/6 x^3/b^2]_0^b Fb 1/EJ$$

$$= (-5/2 b + 5/2 b - 5/6 b) Fb 1/EJ = -5/6 Fb^2/EJ$$

$$L_{CF}^{x\theta} = \int_0^b (-5/2 x^2/b^2) Fb 1/EJ dx = [-5/6 x^3/b^2]_0^b Fb 1/EJ$$

$$= (-5/6 b) Fb 1/EJ = -5/6 Fb^2/EJ$$

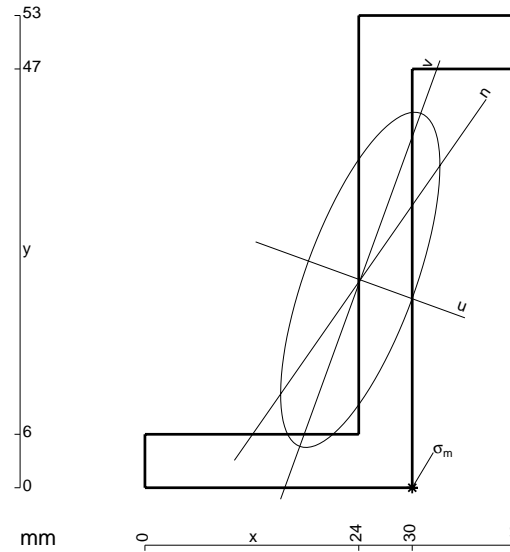

$A = 534. \text{ mm}^2$
 $J_x = 189011. \text{ mm}^4$
 $J_y = 42681. \text{ mm}^4$
 $J_{xy} = 61197. \text{ mm}^4$
 $J_u = 211231. \text{ mm}^4$
 $J_v = 20461. \text{ mm}^4$
 $\alpha = \text{artg}(2J_{xy}/(J_y - J_x))/2 = -.3483$
 $c = \cos \alpha = .9400$
 $s = \sin \alpha = -.3413$
 $x_g = 24.17 \text{ mm}$
 $y_g = 23.33 \text{ mm}$
 $N = -1140. \text{ N}$
 $T_y = 1800. \text{ N}$
 $M_x = 706800. \text{ Nmm}$
 $x_m = 30. \text{ mm}$
 $u_m = 13.44 \text{ mm}$
 $v_m = -19.94 \text{ mm}$
 $\sigma_m = N/A - Mcv/J_u - Msu/J_v = 219.1 \text{ N/mm}^2$

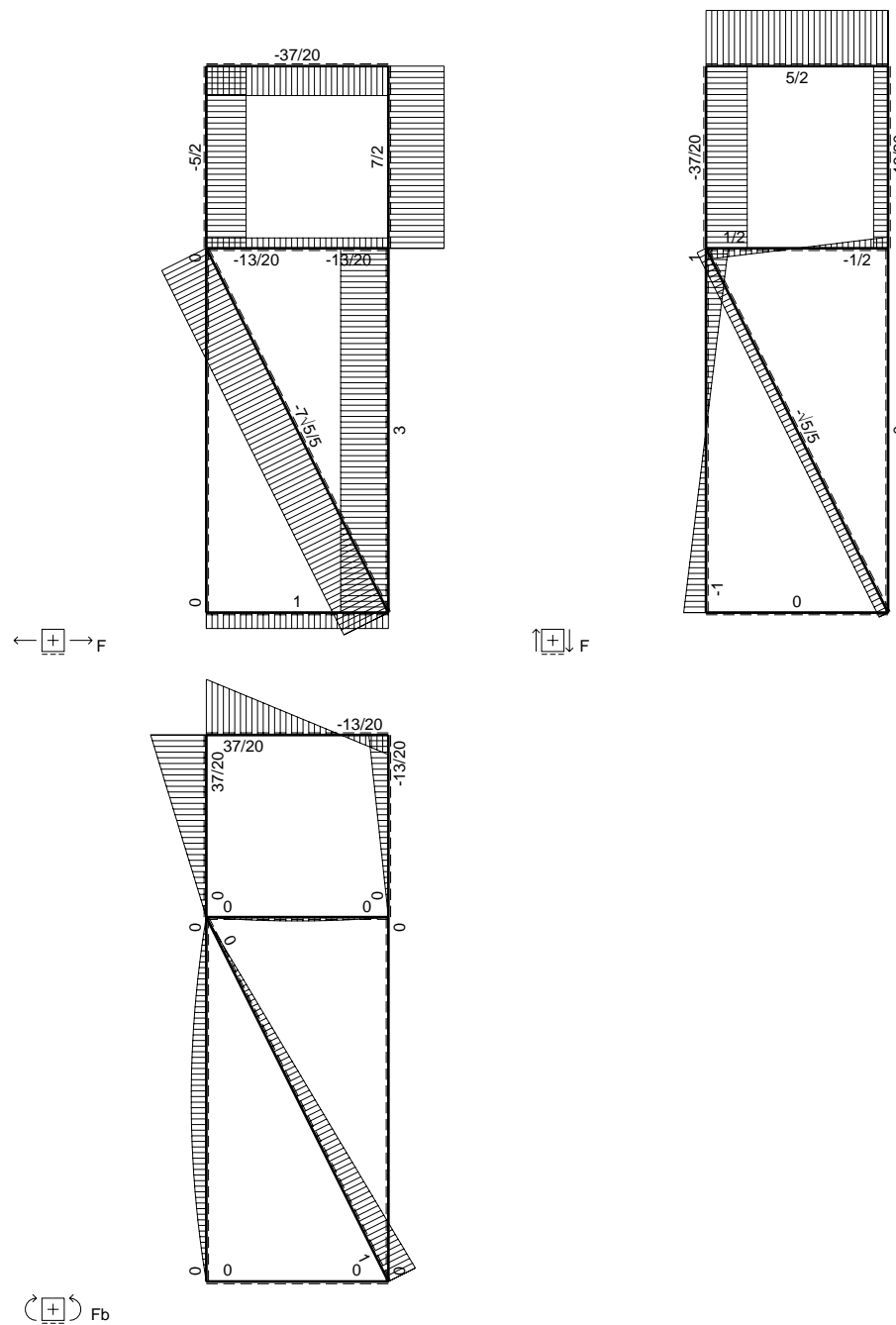
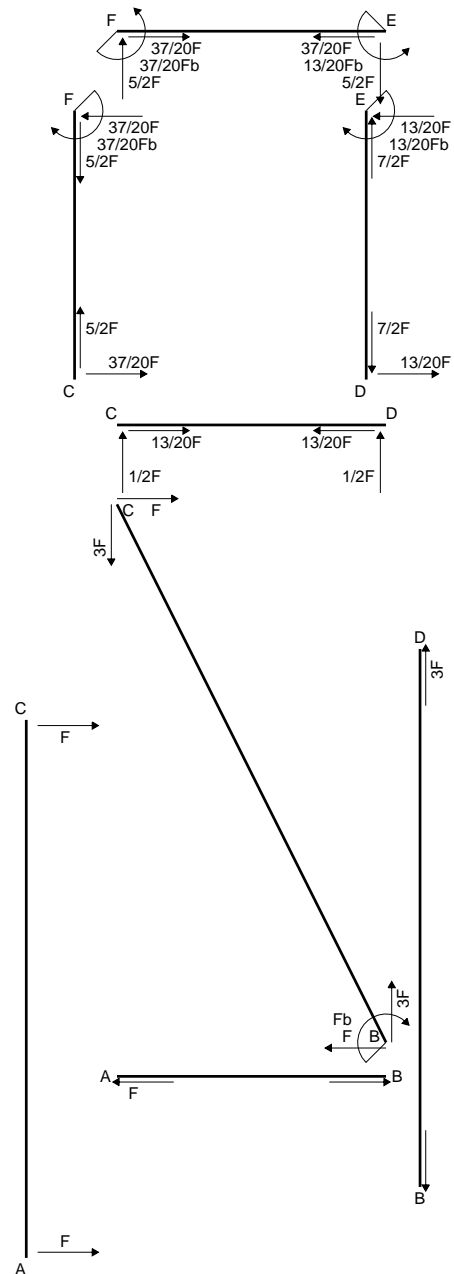

$$L_{DE}^{xx} = \int_0^b (x^2/b^2) 1/EJ dx = [1/3 x^3/b^2]_0^b 1/EJ$$

$$= (1/3 b) 1/EJ = 1/3 b/EJ$$

$$L_{ED}^{xx} = \int_0^b (1 - 2x/b + x^2/b^2) 1/EJ dx = [x - x^2/b + 1/3 x^3/b^2]_0^b 1/EJ$$

$$= (b - b + 1/3 b) 1/EJ = 1/3 b/EJ$$

$$L_{EF}^{xx} = \int_0^b (1) 1/EJ dx = [x]_0^b 1/EJ$$

$$= (b) 1/EJ = b/EJ$$

$$L_{FE}^{xx} = \int_0^b (1) 1/EJ dx = [x]_0^b 1/EJ$$

$$= (b) 1/EJ = b/EJ$$

$$L_{FC}^{xx} = \int_0^b (1 - 2x/b + x^2/b^2) 1/EJ dx = [x - x^2/b + 1/3 x^3/b^2]_0^b 1/EJ$$

$$= (b - b + 1/3 b) 1/EJ = 1/3 b/EJ$$

$$L_{CF}^{xx} = \int_0^b (x^2/b^2) 1/EJ dx = [1/3 x^3/b^2]_0^b 1/EJ$$

$$= (1/3 b) 1/EJ = 1/3 b/EJ$$

$$L_{EF}^{xo} = \int_0^b (-5/2 x/b) Fb 1/EJ dx + \int_0^b (1) \theta dx = [-5/4 x^2/b]_0^b Fb 1/EJ + [x]_0^b \theta$$

$$= (-5/4 b) Fb 1/EJ + (b) \theta = -1/4 Fb^2/EJ$$

$$L_{FE}^{xo} = \int_0^b (-5/2 + 5/2 x/b) Fb 1/EJ dx + \int_0^b (-1) \theta dx = [-5/2 x + 5/4 x^2/b]_0^b Fb 1/EJ + [-x]_0^b \theta$$

$$= (-5/2 b + 5/4 b) Fb 1/EJ + (-b) \theta = -1/4 Fb^2/EJ$$

$$L_{FC}^{xo} = \int_0^b (-5/2 + 5x/b - 5/2 x^2/b^2) Fb 1/EJ dx = [-5/2 x + 5/2 x^2/b - 5/6 x^3/b^2]_0^b Fb 1/EJ$$

$$= (-5/2 b + 5/2 b - 5/6 b) Fb 1/EJ = -5/6 Fb^2/EJ$$

$$L_{CF}^{xo} = \int_0^b (-5/2 x^2/b^2) Fb 1/EJ dx = [-5/6 x^3/b^2]_0^b Fb 1/EJ$$

$$= (-5/6 b) Fb 1/EJ = -5/6 Fb^2/EJ$$

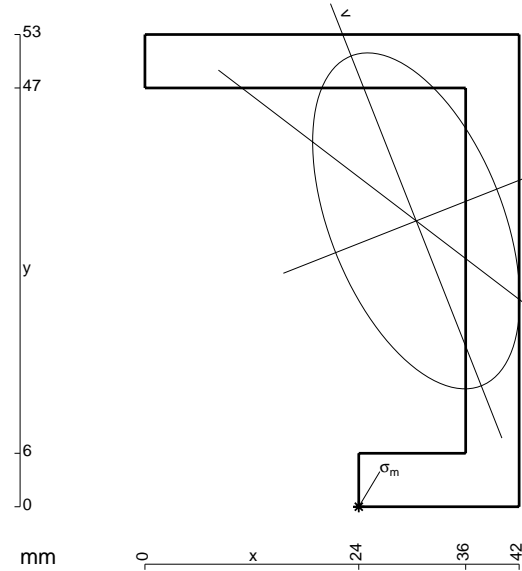

- A = 606. mm²
- J_x = 215454. mm⁴
- J_y = 81888. mm⁴
- J_{xy} = -62420. mm⁴
- J_u = 240083. mm⁴
- J_v = 57258. mm⁴
- α = artg(2J_{xy}/(J_y-J_x))/2 = .3758
- c = cosα = .9302
- s = sinα = .3670
- x_g = 30.45 mm
- y_g = 32.08 mm
- N = -1591. N
- T_y = 2150. N
- M_x = 1050060. Nmm
- x_m = 24. mm
- u_m = -17.77 mm
- v_m = -27.48 mm
- σ_m = N/A - Mcv/J_v - Msu/J_u = 228.8 N/mm²

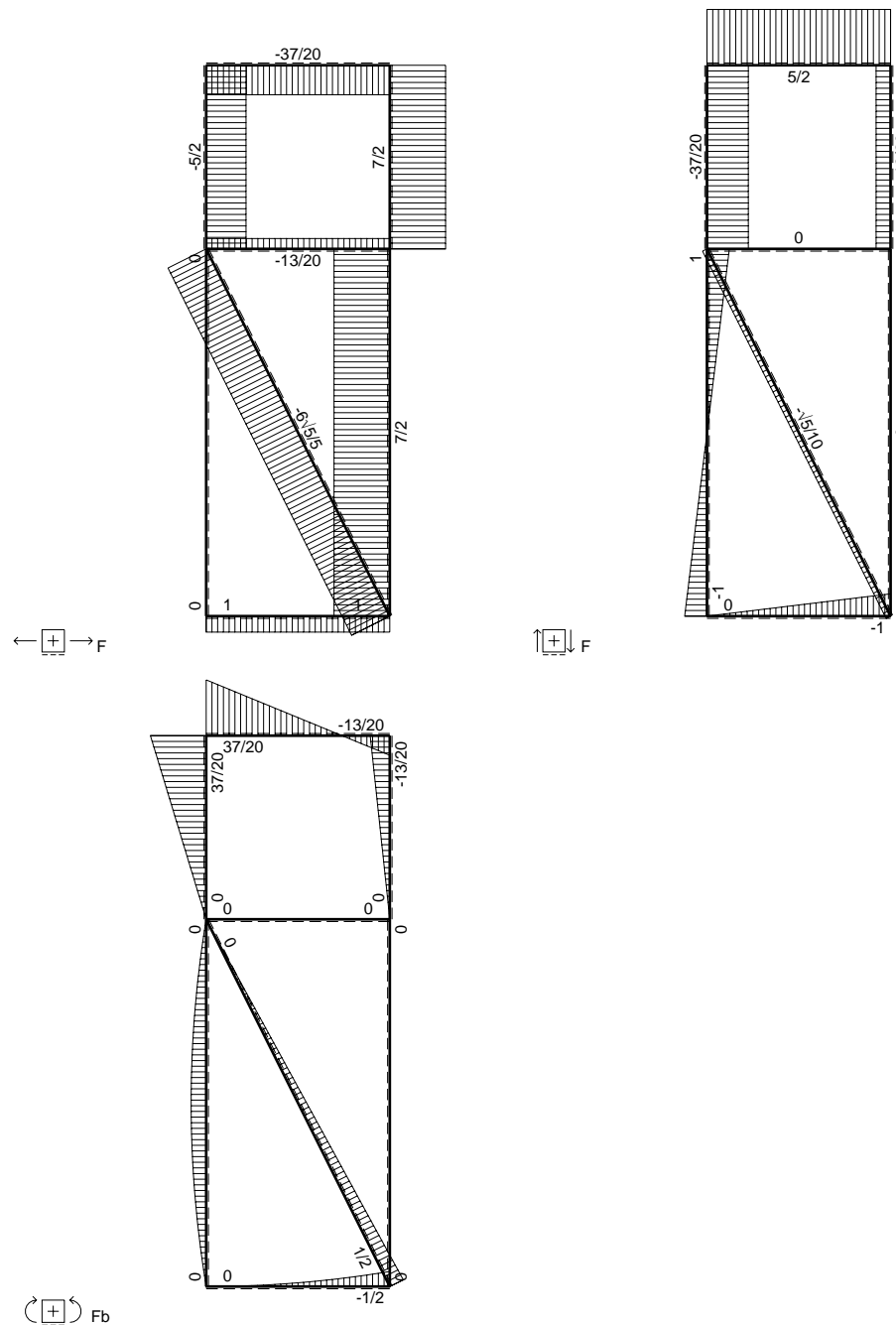
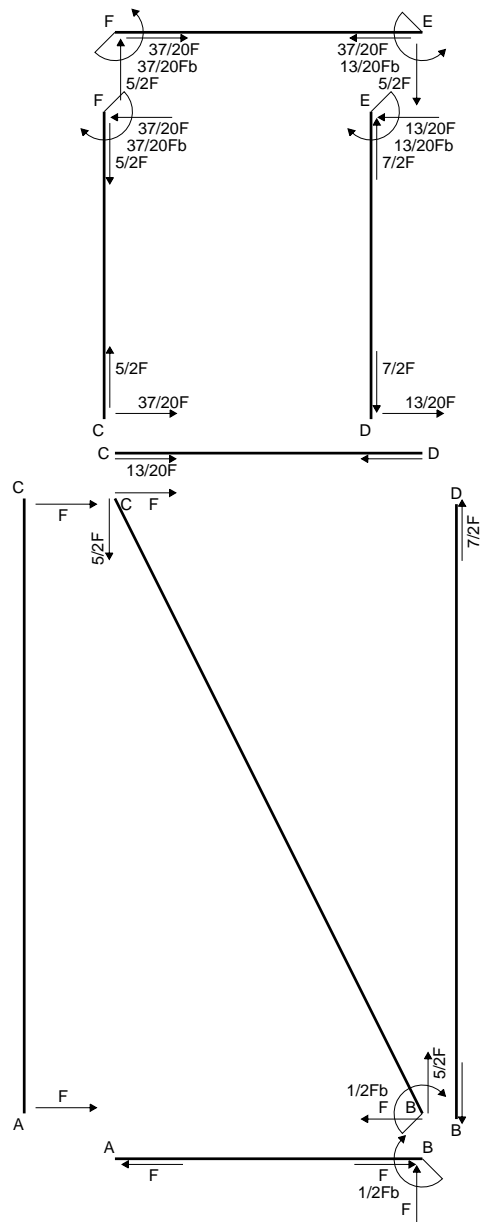

$$L_{DE}^{xx} = \int_0^b (x^2/b^2) 1/EJ dx = [1/3 x^3/b^2]_0^b 1/EJ$$

$$= (1/3 b) 1/EJ = 1/3 b/EJ$$

$$L_{ED}^{xx} = \int_0^b (1 - 2x/b + x^2/b^2) 1/EJ dx = [x - x^2/b + 1/3 x^3/b^2]_0^b 1/EJ$$

$$= (b - b + 1/3 b) 1/EJ = 1/3 b/EJ$$

$$L_{EF}^{xx} = \int_0^b (1) 1/EJ dx = [x]_0^b 1/EJ$$

$$= (b) 1/EJ = b/EJ$$

$$L_{FE}^{xx} = \int_0^b (1) 1/EJ dx = [x]_0^b 1/EJ$$

$$= (b) 1/EJ = b/EJ$$

$$L_{FC}^{xx} = \int_0^b (1 - 2x/b + x^2/b^2) 1/EJ dx = [x - x^2/b + 1/3 x^3/b^2]_0^b 1/EJ$$

$$= (b - b + 1/3 b) 1/EJ = 1/3 b/EJ$$

$$L_{CF}^{xx} = \int_0^b (x^2/b^2) 1/EJ dx = [1/3 x^3/b^2]_0^b 1/EJ$$

$$= (1/3 b) 1/EJ = 1/3 b/EJ$$

$$L_{EF}^{xo} = \int_0^b (-5/2 x/b) Fb 1/EJ dx + \int_0^b (1) \theta dx = [-5/4 x^2/b]_0^b Fb 1/EJ + [x]_0^b \theta$$

$$= (-5/4 b) Fb 1/EJ + (b) \theta = -1/4 Fb^2/EJ$$

$$L_{FE}^{xo} = \int_0^b (-5/2 + 5/2 x/b) Fb 1/EJ dx + \int_0^b (-1) \theta dx = [-5/2 x + 5/4 x^2/b]_0^b Fb 1/EJ + [-x]_0^b \theta$$

$$= (-5/2 b + 5/4 b) Fb 1/EJ + (-b) \theta = -1/4 Fb^2/EJ$$

$$L_{FC}^{xo} = \int_0^b (-5/2 + 5x/b - 5/2 x^2/b^2) Fb 1/EJ dx = [-5/2 x + 5/2 x^2/b - 5/6 x^3/b^2]_0^b Fb 1/EJ$$

$$= (-5/2 b + 5/2 b - 5/6 b) Fb 1/EJ = -5/6 Fb^2/EJ$$

$$L_{CF}^{xo} = \int_0^b (-5/2 x^2/b^2) Fb 1/EJ dx = [-5/6 x^3/b^2]_0^b Fb 1/EJ$$

$$= (-5/6 b) Fb 1/EJ = -5/6 Fb^2/EJ$$

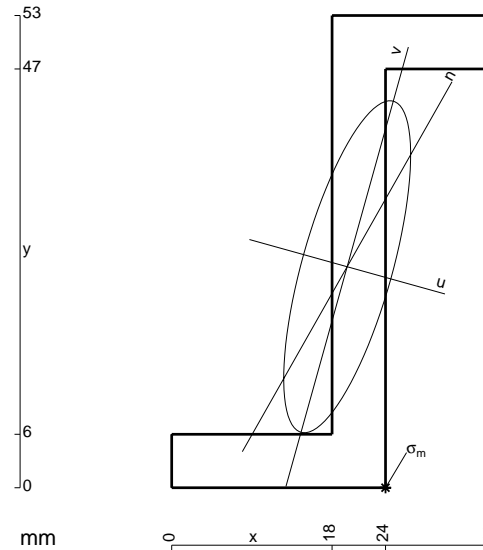

- A = 498. mm²
- J_x = 172946. mm⁴
- J_y = 25275. mm⁴
- J_{xy} = 44583. mm⁴
- J_u = 185362. mm⁴
- J_v = 12859. mm⁴
- α = arctg(2J_{xy}/(J_y-J_x))/2 = -.2716
- c = cosα = .9633
- s = sinα = -.2683
- x_g = 19.7 mm
- y_g = 24.8 mm
- N = -999. N
- T_y = 1350. N
- M_x = 699300. Nmm
- x_m = 24. mm
- u_m = 10.8 mm
- v_m = -22.74 mm
- σ_m = N/A - Mcv/J_u - Msu/J_v = 238.2 N/mm²

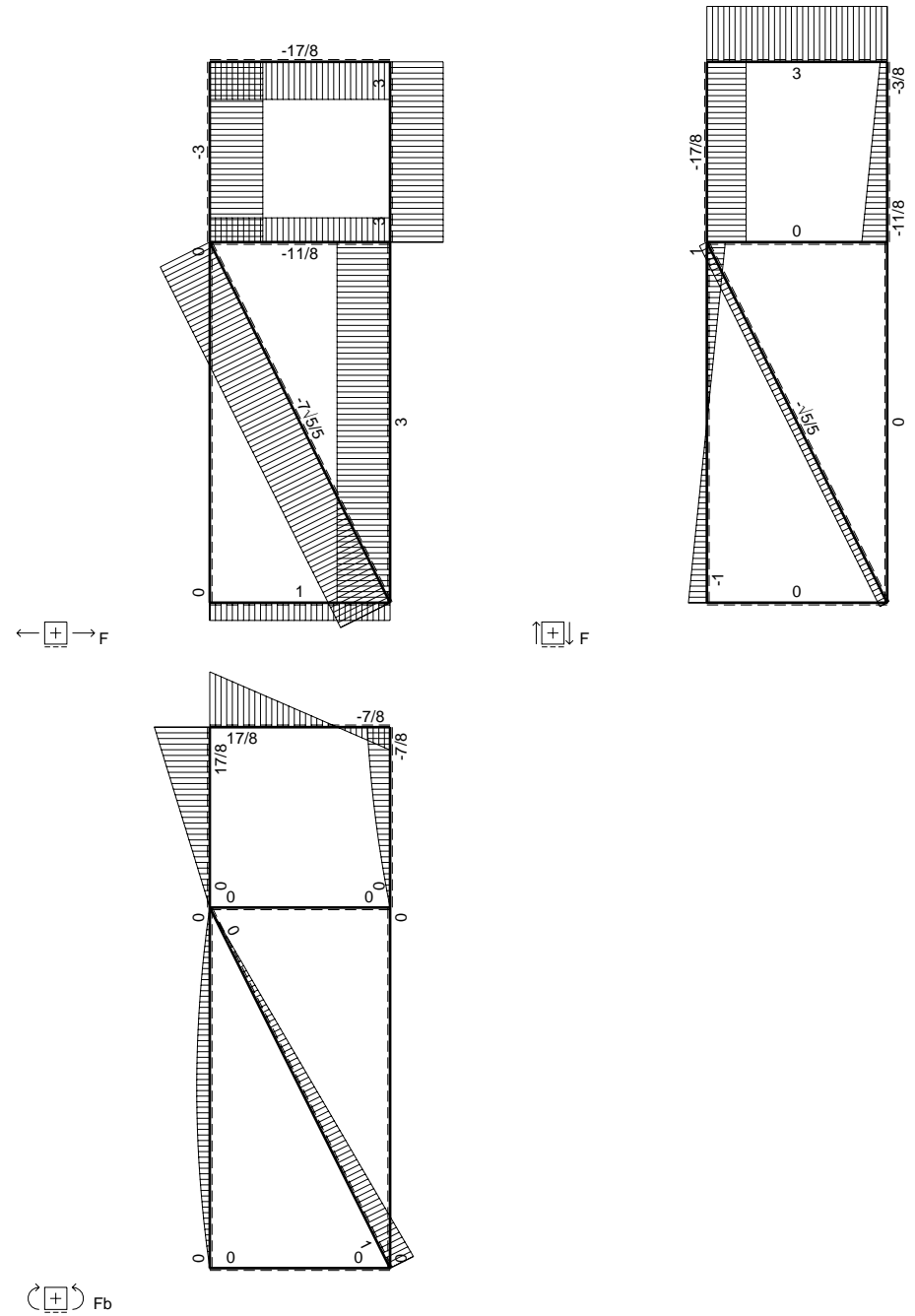
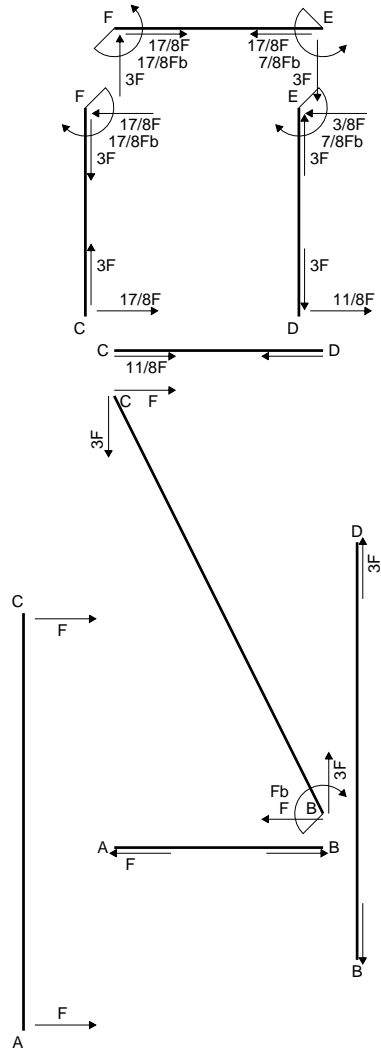

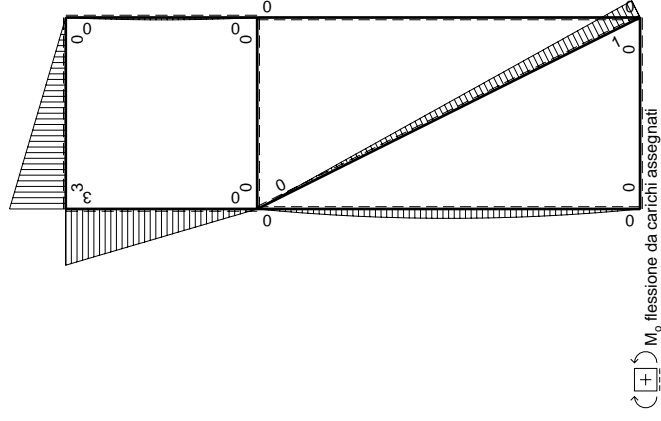
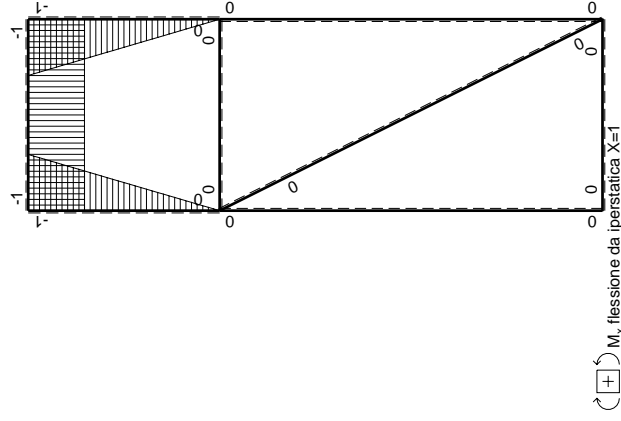
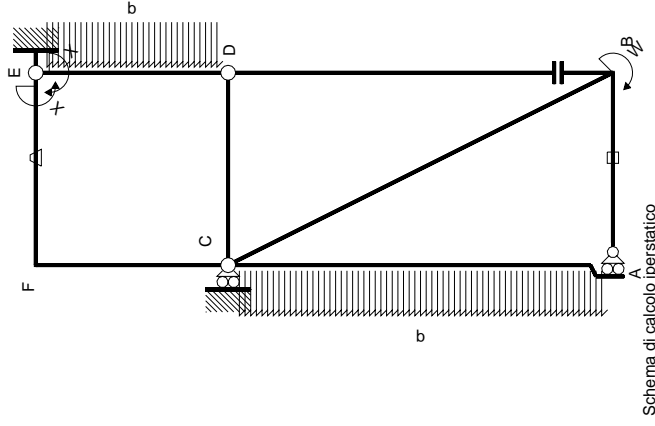

Quadro contributi PLV per iperstatica $X=W_{EF}$

\leftarrow	$M^x(x)$	$M^0(x)$	θ	$M^x M_0$	$M^x \theta$	$M^x M_x$	$\int M^x (M_0/EJ + \theta) dx$	$\int M^x M_x / EJ dx$
AB b	0	0	0	0	0	0	0+0	0
BA b	0	0	0	0	0	0	0	0
BC $\sqrt{5}b$	0	$Fb - \sqrt{5}/5Fx$	0	0	0	0	0	0
AC 2b	0	$-Fx + 1/2qx^2$	0	0	0	0	0+0	0
CA 2b	0	$Fx - 1/2qx^2$	0	0	0	0	0	0
DB 2b	0	0	0	0	0	0	0+0	0
BD 2b	0	0	0	0	0	0	0	0
DE b	$-x/b$	$-1/2Fx + 1/2qx^2$	0	$1/2Fx^2/b - 1/2qx^3/b$	0	0	x^2/b^2	0
ED b	$1-x/b$	$1/2Fx - 1/2qx^2$	0	$1/2Fx - Fx^2/b + 1/2qx^3/b$	0	0	$1-2x/b+x^2/b^2$	$1/3Xb/EJ$
CD b	0	0	0	0	0	0	0+0	0
DC b	0	0	0	0	0	0	0	0
EF b	-1	$3Fx$	$-Fb/EJ$	$-3Fx$	Fb/EJ	Fb/EJ	$(-3/2+1)Fb^2/EJ$	Xb/EJ
FE b	1	$-3Fb+3Fx$	Fb/EJ	$-3Fb+3Fx$	Fb/EJ	Fb/EJ	$(-3/2+1)Fb^2/EJ$	Xb/EJ
FC b	$-1+x/b$	$3Fb-3Fx$	0	$-3Fb+6Fx-3Fx^2/b$	0	0	$1-2x/b+x^2/b^2$	$(-1+0)Fb^2/EJ$
CF b	x/b	$-3Fx$	0	$-3Fx^2/b$	0	0	x^2/b^2	$1/3Xb/EJ$
totali								$5/3Xb/EJ$
								$7/8Fb$

Sviluppi di calcolo iperstatica

$$L_{DE}^{xx} = \int_0^b (x^2/b^2) 1/EJ dx = [1/3 x^3/b^2]_0^b 1/EJ$$

$$= (1/3 b) 1/EJ = 1/3 b/EJ$$

$$L_{ED}^{xx} = \int_0^b (1 - 2x/b + x^2/b^2) 1/EJ dx = [x - x^2/b + 1/3 x^3/b^2]_0^b 1/EJ$$

$$= (b - b + 1/3 b) 1/EJ = 1/3 b/EJ$$

$$L_{EF}^{xx} = \int_0^b (1) 1/EJ dx = [x]_0^b 1/EJ$$

$$= (b) 1/EJ = b/EJ$$

$$L_{FE}^{xx} = \int_0^b (1) 1/EJ dx = [x]_0^b 1/EJ$$

$$= (b) 1/EJ = b/EJ$$

$$L_{FC}^{xx} = \int_0^b (1 - 2x/b + x^2/b^2) 1/EJ dx = [x - x^2/b + 1/3 x^3/b^2]_0^b 1/EJ$$

$$= (b - b + 1/3 b) 1/EJ = 1/3 b/EJ$$

$$L_{CF}^{xx} = \int_0^b (x^2/b^2) 1/EJ dx = [1/3 x^3/b^2]_0^b 1/EJ$$

$$= (1/3 b) 1/EJ = 1/3 b/EJ$$

$$L_{DE}^{xo} = \int_0^b (1/2 x^2/b^2 - 1/2 x^3/b^3) Fb 1/EJ dx = [1/6 x^3/b^2 - 1/8 x^4/b^3]_0^b Fb 1/EJ$$

$$= (1/6 b - 1/8 b) Fb 1/EJ = 1/24 Fb^2/EJ$$

$$L_{ED}^{xo} = \int_0^b (1/2 x/b - x^2/b^2 + 1/2 x^3/b^3) Fb 1/EJ dx = [1/4 x^2/b - 1/3 x^3/b^2 + 1/8 x^4/b^3]_0^b Fb 1/EJ$$

$$= (1/4 b - 1/3 b + 1/8 b) Fb 1/EJ = 1/24 Fb^2/EJ$$

$$L_{EF}^{xo} = \int_0^b (-3x/b) Fb 1/EJ dx + \int_0^b (1) \theta dx = [-3/2 x^2/b]_0^b Fb 1/EJ + [x]_0^b \theta$$

$$= (-3/2 b) Fb 1/EJ + (b) \theta = -1/2 Fb^2/EJ$$

$$L_{FE}^{xo} = \int_0^b (-3 + 3x/b) Fb 1/EJ dx + \int_0^b (-1) \theta dx = [-3x + 3/2 x^2/b]_0^b Fb 1/EJ + [-x]_0^b \theta$$

$$= (-3b + 3/2 b) Fb 1/EJ + (-b) \theta = -1/2 Fb^2/EJ$$

$$L_{FC}^{xo} = \int_0^b (-3 + 6x/b - 3x^2/b^2) Fb 1/EJ dx = [-3x + 3x^2/b - x^3/b^2]_0^b Fb 1/EJ$$

$$= (-3b + 3b - b) Fb 1/EJ = - Fb^2/EJ$$

$$L_{CF}^{xo} = \int_0^b (-3x^2/b^2) Fb 1/EJ dx = [-x^3/b^2]_0^b Fb 1/EJ$$

$$= (-b) Fb 1/EJ = - Fb^2/EJ$$

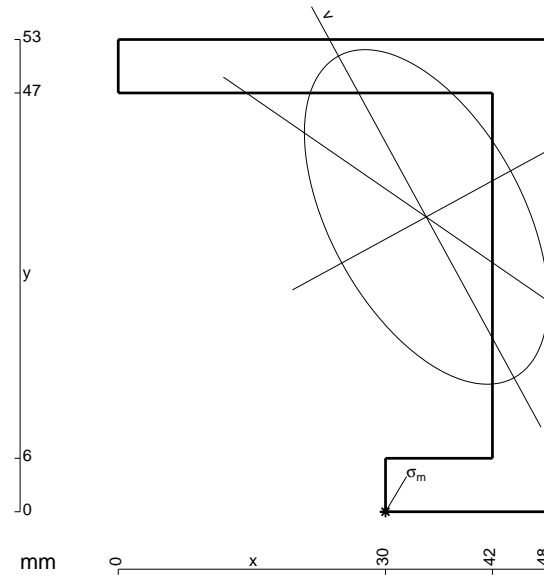

- A = 642. mm²
- J_x = 226469. mm⁴
- J_y = 120007. mm⁴
- J_{xy} = -82782. mm⁴
- J_u = 271657. mm⁴
- J_v = 74819. mm⁴
- α = arctg(2J_{xy}/(J_y-J_x))/2 = .4997
- c = cosα = .8777
- s = sinα = .4791
- x_g = 34.57 mm
- y_g = 33.09 mm
- N = -2571. N
- T_y = 3630. N
- M_x = 951363. Nmm
- x_m = 30. mm
- u_m = -19.87 mm
- v_m = -26.85 mm
- σ_m = N/A - Mcv/J_u - Msu/J_v = 199.6 N/mm²

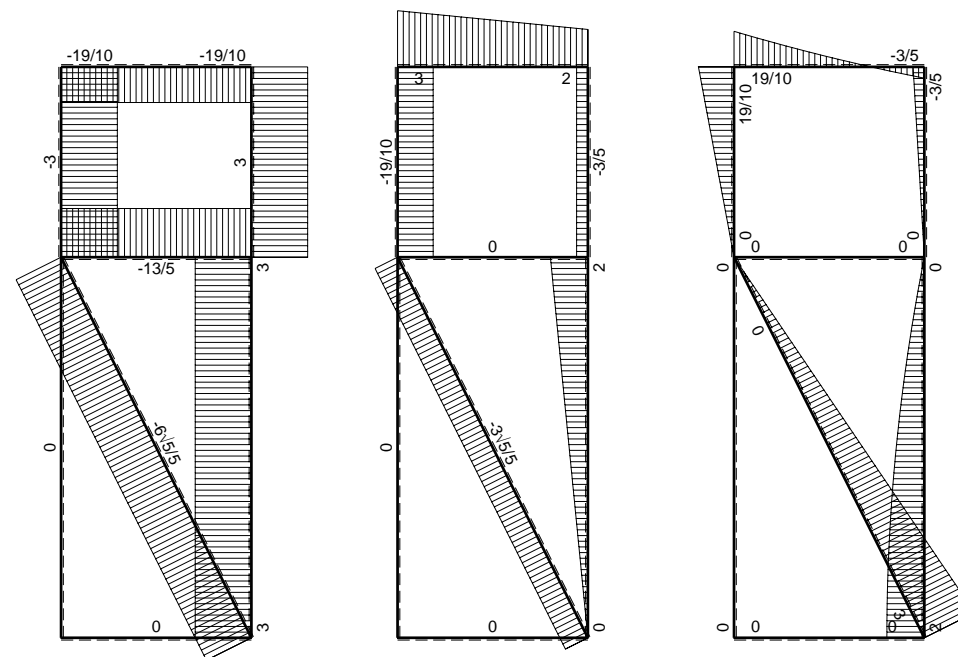
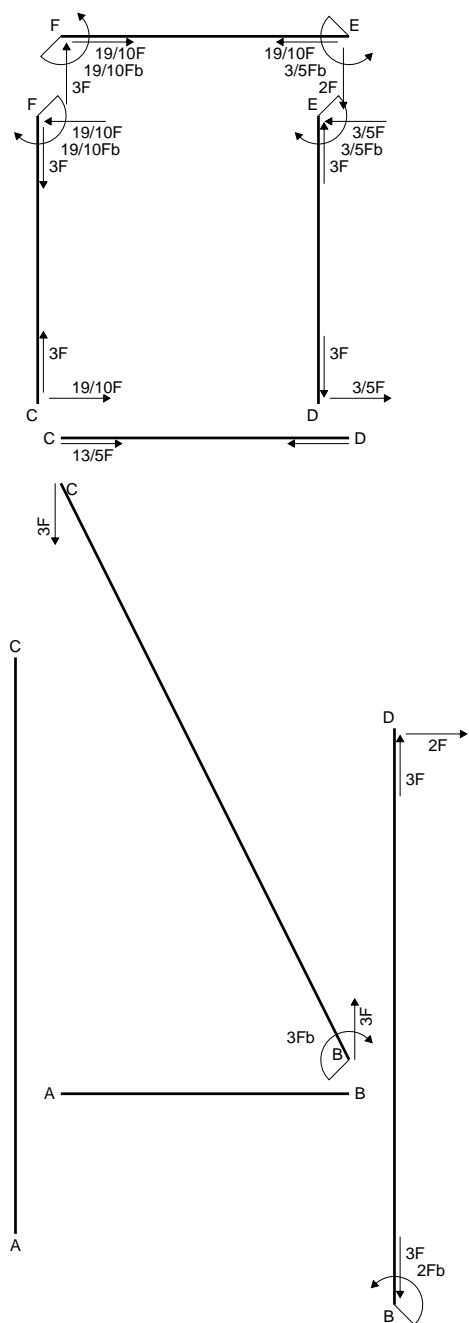

← ⊕ → F

↑ ⊕ ↓ F

⊕ ⊖ F_b

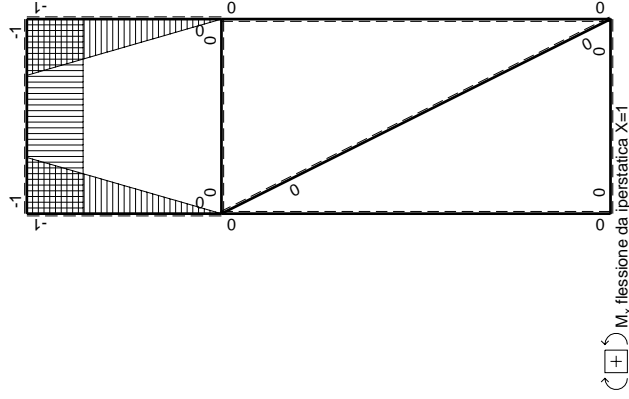
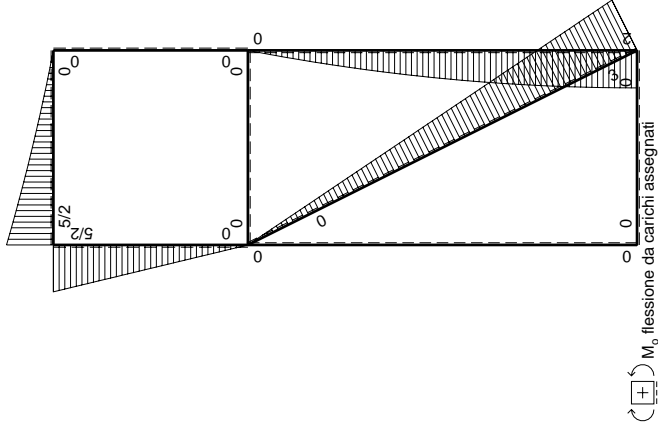
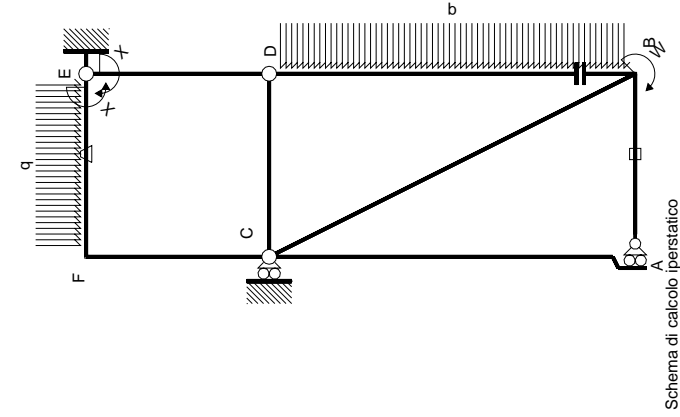

Quadro contributi PLV per iperstatica X=W^{EF}

←	M ^x (x)	M ^o (x)	θ	M ^x M _o	M ^x θ	M ^x M _x	∫M ^x (M _o /EJ+θ)dx	∫M ^x M _x /EJdx	
AB b	0	0	0	0	0	0	0+0	0	
BA b	0	0	0	0	0	0	0	0	
BC √5b	0	3Fb-3√5/5Fx	0	0	0	0	0+0	0	
AC 2b	0	0	0	0	0	0	0+0	0	
CA 2b	0	0	0	0	0	0	0	0	
DB 2b	0	2Fx-1/2qx ²	0	0	0	0	0+0	0	
BD 2b	0	-2Fb+1/2qx ²	0	0	0	0	0+0	0	
DE b	-x/b	0	0	0	0	x ² /b ²	0+0	1/3xb/EJ	
ED b	1-x/b	0	0	0	0	1-2x/b+x ² /b ²	0+0	1/3xb/EJ	
CD b	0	0	0	0	0	0	0+0	0	
DC b	0	0	0	0	0	0	0+0	0	
EF b	-1	2Fx+1/2qx ²	-Fb/EJ	-2Fx-1/2Fx ² /b	Fb/EJ	1	(-7/6+1)Fb ² /EJ	Xb/EJ	
FE b	1	-5/2Fb+3Fx-1/2qx ²	Fb/EJ	-5/2Fb+3Fx-1/2Fx ² /b	Fb/EJ	1	(-7/6+1)Fb ² /EJ	Xb/EJ	
FC b	-1+x/b	5/2Fb-5/2Fx	0	-5/2Fb+5Fx-5/2Fx ² /b	0	1-2x/b+x ² /b ²	(-5/6+0)Fb ² /EJ	1/3xb/EJ	
CF b	x/b	-5/2Fx	0	-5/2Fx ² /b	0	x ² /b ²	(-5/6+0)Fb ² /EJ	1/3xb/EJ	
totali								-Fb ² /EJ	5/3xb/EJ
								iperstatica X=W ^{EF}	

Sviluppi di calcolo iperstatica

$$L_{DE}^{xx} = \int_0^b (x^2/b^2) 1/EJ dx = [1/3 x^3/b^2]_0^b 1/EJ$$

$$= (1/3 b) 1/EJ = 1/3 b/EJ$$

$$L_{ED}^{xx} = \int_0^b (1 - 2x/b + x^2/b^2) 1/EJ dx = [x - x^2/b + 1/3 x^3/b^2]_0^b 1/EJ$$

$$= (b - b + 1/3 b) 1/EJ = 1/3 b/EJ$$

$$L_{EF}^{xx} = \int_0^b (1) 1/EJ dx = [x]_0^b 1/EJ$$

$$= (b) 1/EJ = b/EJ$$

$$L_{FE}^{xx} = \int_0^b (1) 1/EJ dx = [x]_0^b 1/EJ$$

$$= (b) 1/EJ = b/EJ$$

$$L_{FC}^{xx} = \int_0^b (1 - 2x/b + x^2/b^2) 1/EJ dx = [x - x^2/b + 1/3 x^3/b^2]_0^b 1/EJ$$

$$= (b - b + 1/3 b) 1/EJ = 1/3 b/EJ$$

$$L_{CF}^{xx} = \int_0^b (x^2/b^2) 1/EJ dx = [1/3 x^3/b^2]_0^b 1/EJ$$

$$= (1/3 b) 1/EJ = 1/3 b/EJ$$

$$L_{EF}^{xo} = \int_0^b (-2x/b - 1/2 x^2/b^2) Fb 1/EJ dx + \int_0^b (1) \theta dx = [-x^2/b - 1/6 x^3/b^2]_0^b Fb 1/EJ + [x]_0^b \theta$$

$$= (-b - 1/6 b) Fb 1/EJ + (b) \theta = -1/6 Fb^2/EJ$$

$$L_{FE}^{xo} = \int_0^b (-5/2 + 3x/b - 1/2 x^2/b^2) Fb 1/EJ dx + \int_0^b (-1) \theta dx$$

$$= [-5/2 x + 3/2 x^2/b - 1/6 x^3/b^2]_0^b Fb 1/EJ + [-x]_0^b \theta$$

$$= (-5/2 b + 3/2 b - 1/6 b) Fb 1/EJ + (-b) \theta = -1/6 Fb^2/EJ$$

$$L_{FC}^{xo} = \int_0^b (-5/2 + 5x/b - 5/2 x^2/b^2) Fb 1/EJ dx = [-5/2 x + 5/2 x^2/b - 5/6 x^3/b^2]_0^b Fb 1/EJ$$

$$= (-5/2 b + 5/2 b - 5/6 b) Fb 1/EJ = -5/6 Fb^2/EJ$$

$$L_{CF}^{xo} = \int_0^b (-5/2 x^2/b^2) Fb 1/EJ dx = [-5/6 x^3/b^2]_0^b Fb 1/EJ$$

$$= (-5/6 b) Fb 1/EJ = -5/6 Fb^2/EJ$$

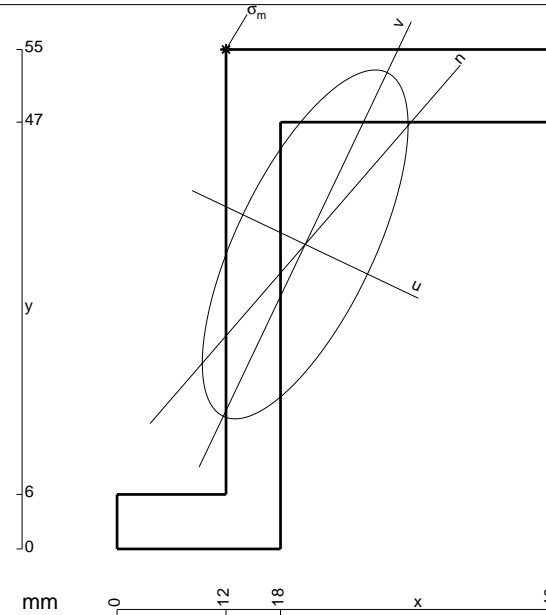

- A = 642. mm²
- J_x = 237041. mm⁴
- J_y = 82444. mm⁴
- J_{xy} = 95227. mm⁴
- J_u = 282393. mm⁴
- J_v = 37091. mm⁴
- α = artg(2J_{xy}/(J_y-J_x))/2 = -.4445
- c = cosα = .9028
- s = sinα = -.4300
- x_g = 20.72 mm
- y_g = 33.54 mm
- N = -1771. N
- T_y = -885.5 N
- M_x = 831600. Nmm
- x_m = 12. mm
- y_m = 55. mm
- u_m = -17.1 mm
- v_m = 15.63 mm
- σ_m = N/A - Mcv/J_u - Msu/J_v = -209.2 N/mm²

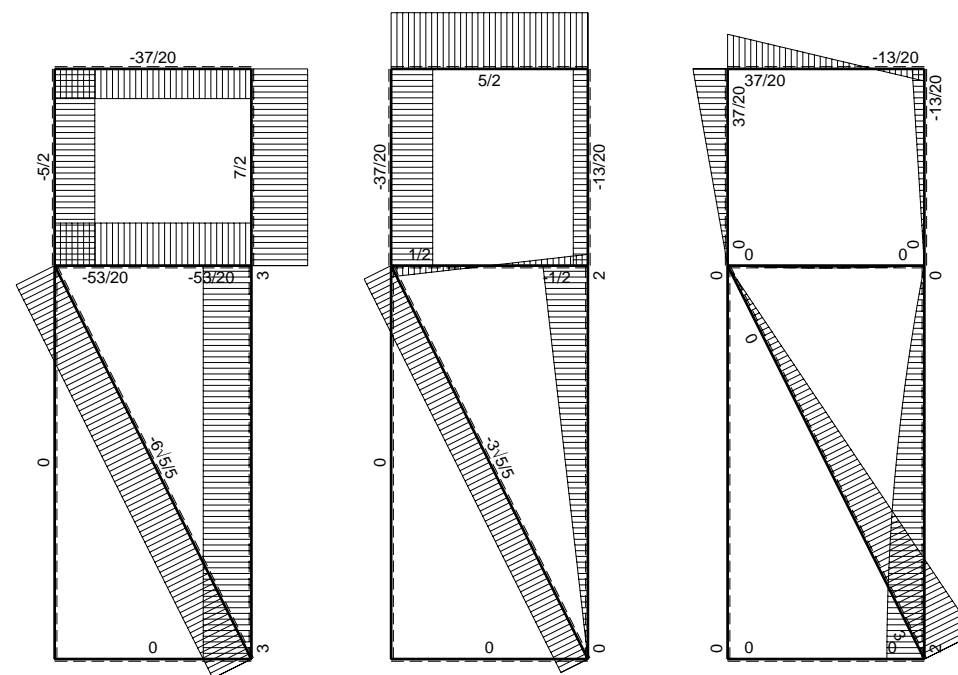
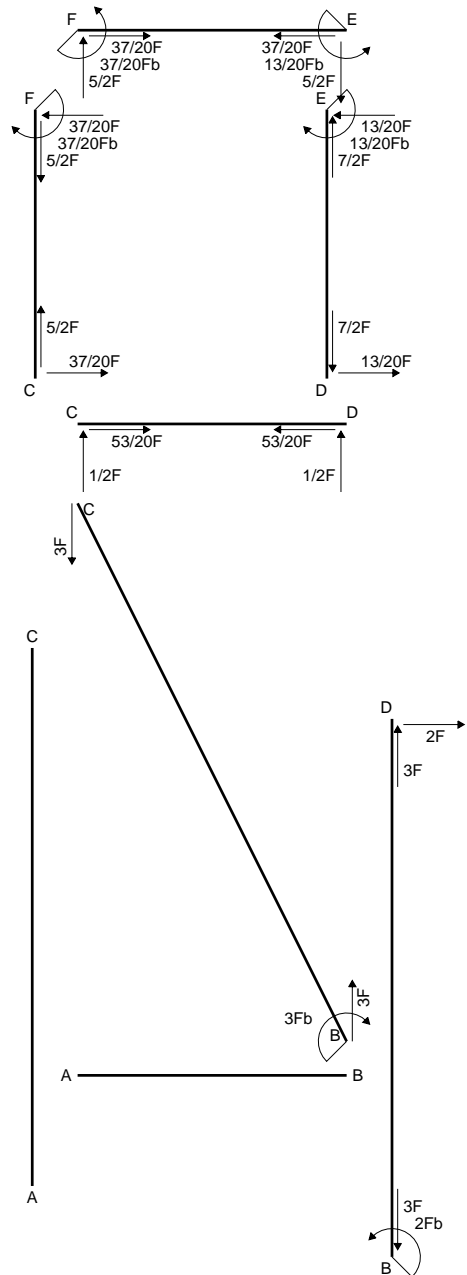

← ⊕ → F

↑ ⊕ ↓ F

⊕ ⊖ F_b

$$L_{DE}^{xx} = \int_0^b (x^2/b^2) 1/EJ dx = [1/3 x^3/b^2]_0^b 1/EJ$$

$$= (1/3 b) 1/EJ = 1/3 b/EJ$$

$$L_{ED}^{xx} = \int_0^b (1 - 2x/b + x^2/b^2) 1/EJ dx = [x - x^2/b + 1/3 x^3/b^2]_0^b 1/EJ$$

$$= (b - b + 1/3 b) 1/EJ = 1/3 b/EJ$$

$$L_{EF}^{xx} = \int_0^b (1) 1/EJ dx = [x]_0^b 1/EJ$$

$$= (b) 1/EJ = b/EJ$$

$$L_{FE}^{xx} = \int_0^b (1) 1/EJ dx = [x]_0^b 1/EJ$$

$$= (b) 1/EJ = b/EJ$$

$$L_{FC}^{xx} = \int_0^b (1 - 2x/b + x^2/b^2) 1/EJ dx = [x - x^2/b + 1/3 x^3/b^2]_0^b 1/EJ$$

$$= (b - b + 1/3 b) 1/EJ = 1/3 b/EJ$$

$$L_{CF}^{xx} = \int_0^b (x^2/b^2) 1/EJ dx = [1/3 x^3/b^2]_0^b 1/EJ$$

$$= (1/3 b) 1/EJ = 1/3 b/EJ$$

$$L_{EF}^{xo} = \int_0^b (-5/2 x/b) Fb 1/EJ dx + \int_0^b (1) \theta dx = [-5/4 x^2/b]_0^b Fb 1/EJ + [x]_0^b \theta$$

$$= (-5/4 b) Fb 1/EJ + (b) \theta = -1/4 Fb^2/EJ$$

$$L_{FE}^{xo} = \int_0^b (-5/2 + 5/2 x/b) Fb 1/EJ dx + \int_0^b (-1) \theta dx = [-5/2 x + 5/4 x^2/b]_0^b Fb 1/EJ + [-x]_0^b \theta$$

$$= (-5/2 b + 5/4 b) Fb 1/EJ + (-b) \theta = -1/4 Fb^2/EJ$$

$$L_{FC}^{xo} = \int_0^b (-5/2 + 5x/b - 5/2 x^2/b^2) Fb 1/EJ dx = [-5/2 x + 5/2 x^2/b - 5/6 x^3/b^2]_0^b Fb 1/EJ$$

$$= (-5/2 b + 5/2 b - 5/6 b) Fb 1/EJ = -5/6 Fb^2/EJ$$

$$L_{CF}^{xo} = \int_0^b (-5/2 x^2/b^2) Fb 1/EJ dx = [-5/6 x^3/b^2]_0^b Fb 1/EJ$$

$$= (-5/6 b) Fb 1/EJ = -5/6 Fb^2/EJ$$

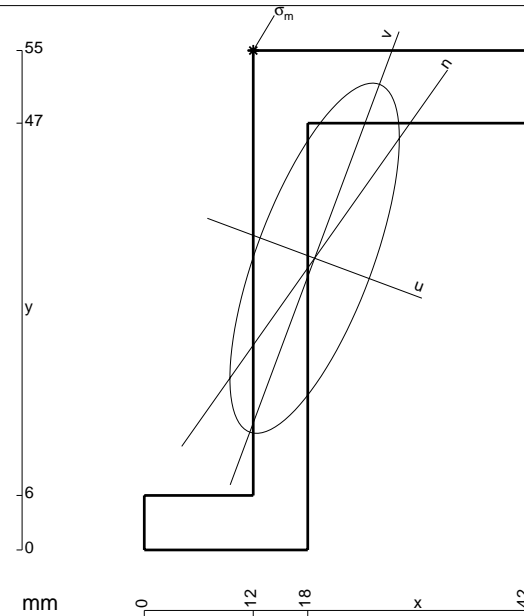

- A = 594. mm²
- J_x = 220965. mm⁴
- J_y = 51715. mm⁴
- J_{xy} = 73230. mm⁴
- J_u = 248250. mm⁴
- J_v = 24429. mm⁴
- α = arctg(2J_{xy}/(J_y-J_x))/2 = -.3567
- c = cos α = .9371
- s = sin α = -.3492
- x_g = 18.76 mm
- y_g = 32.13 mm
- N = -1503. N
- T_y = -751.3 N
- M_x = 772800. Nmm
- x_m = 12. mm
- y_m = 55. mm
- u_m = -14.32 mm
- v_m = 19.07 mm
- σ_m = N/A - Mc_v/J_u - Ms_u/J_v = -216.3 N/mm²

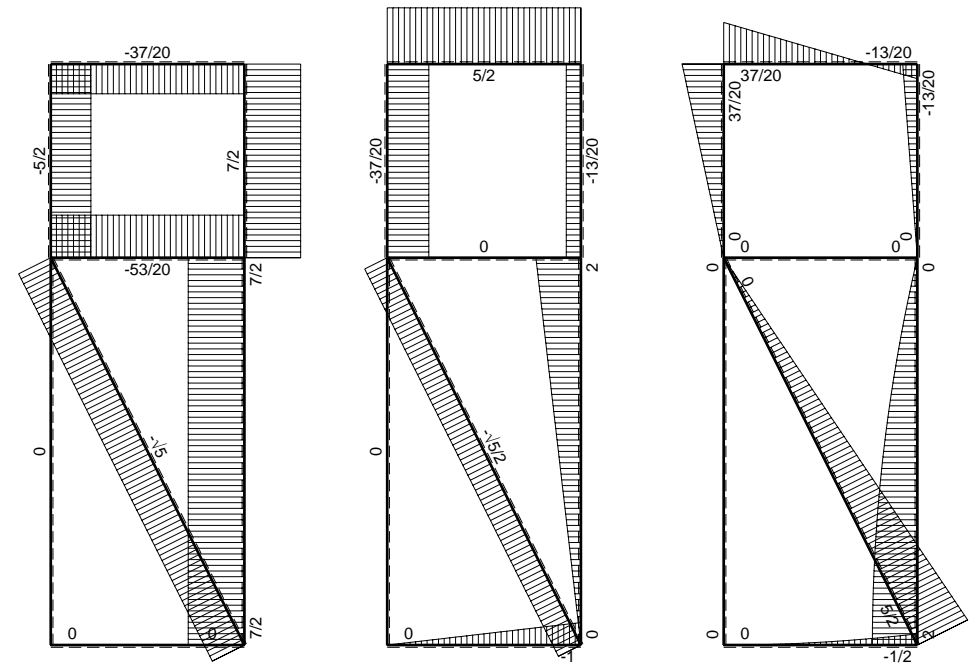
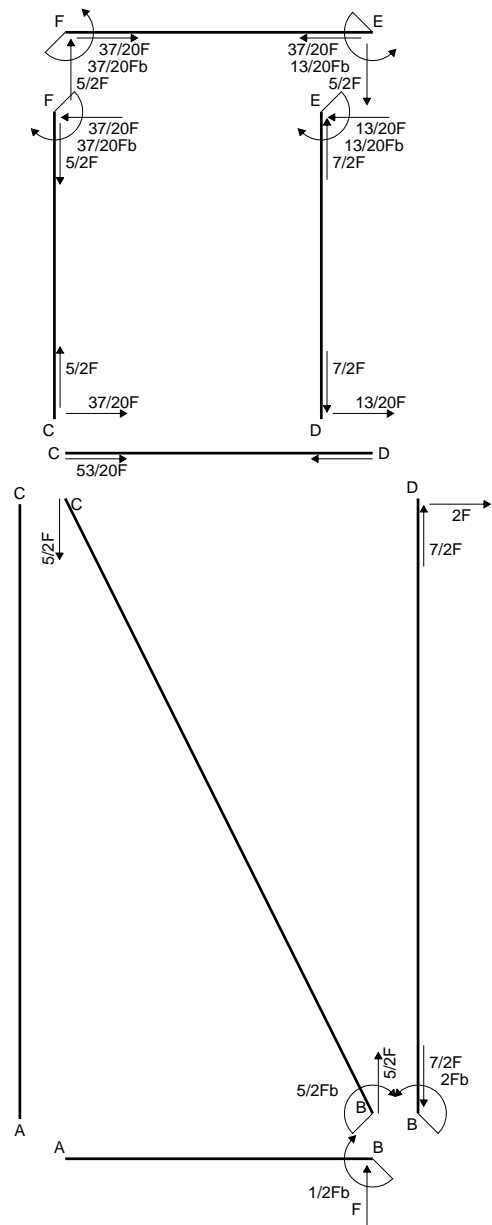

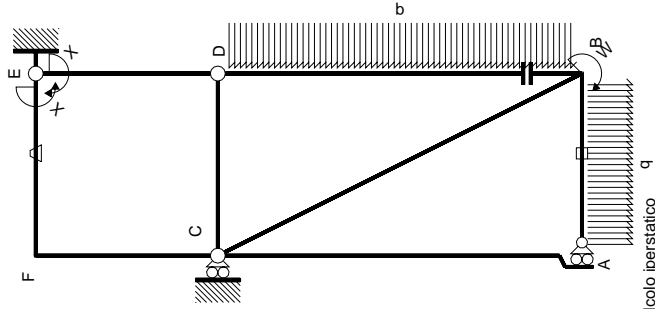

Schema di calcolo iperstatico q

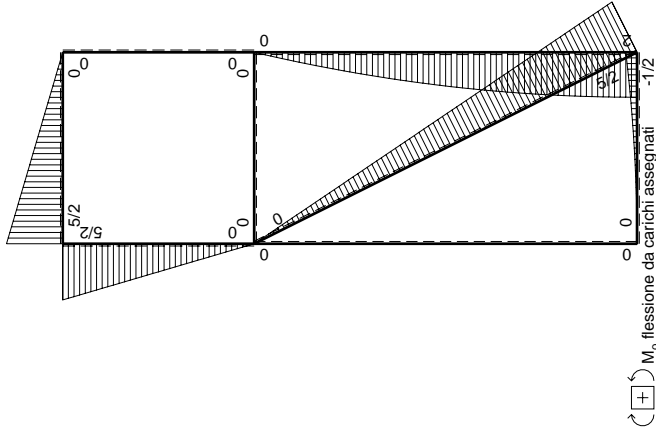

M_0 flessione da carichi assegnati

Quadro contributi PLV per iperstatica $X=W_{EP}$

\rightarrow	$M(x)$	$M_0(x)$	θ	$M_x M_0$	$M_x \theta$	$M_x M_x$	$\int M_x(M_0/EJ+\theta)dx$	$\int M_x M_x/EJdx$
AB b	0	$-1/2qx^2$	0	0	0	0	0+0	0
BA b	0	$1/2Fb-Fx+1/2qx^2$	0	0	0	0	0	0
BC $\sqrt{5}b$	0	$5/2Fb-\sqrt{5}2Fx$	0	0	0	0	0	0
CA 2b	0	0	0	0	0	0	0+0	0
DB 2b	0	$2Fx-1/2qx^2$	0	0	0	0	0+0	0
BD 2b	0	$-2Fb+1/2qx^2$	0	0	0	0	0+0	0
DE b	$-x/b$	0	0	0	0	0	0+0	0
ED b	$1-x/b$	0	0	0	0	0	0+0	0
CD b	0	0	0	0	0	0	0	0
DC b	0	0	0	0	0	0	0+0	0
EF b	-1	$5/2Fx$	$-Fb/EJ$	$-5/2Fx$	Fb/EJ	1	$(-5/4+1)Fb^2/EJ$	Xb/EJ
FE b	1	$-5/2Fb+5/2Fx$	Fb/EJ	$-5/2Fb+5/2Fx$	Fb/EJ	1	$(-5/4+1)Fb^2/EJ$	Xb/EJ
FC b	$-1+x/b$	$5/2Fb-5/2Fx$	0	$-5/2Fb+5Fx-5/2Fx^2/b$	0	$1-2x/b+x^2/b^2$	$(-5/6+0)Fb^2/EJ$	$1/3Xb/EJ$
CF b	x/b	$-5/2Fx$	0	$-5/2Fx^2/b$	0	x^2/b^2	$-13/12Fb^2/EJ$	$5/3Xb/EJ$
totali								
iperstatica $X=W_{EP}$								

Sviluppi di calcolo iperstatica

$$L_{DE}^{xx} = \int_0^b (x^2/b^2) 1/EJ dx = [1/3 x^3/b^2]_0^b 1/EJ$$

$$= (1/3 b) 1/EJ = 1/3 b/EJ$$

$$L_{ED}^{xx} = \int_0^b (1 - 2x/b + x^2/b^2) 1/EJ dx = [x - x^2/b + 1/3 x^3/b^2]_0^b 1/EJ$$

$$= (b - b + 1/3 b) 1/EJ = 1/3 b/EJ$$

$$L_{EF}^{xx} = \int_0^b (1) 1/EJ dx = [x]_0^b 1/EJ$$

$$= (b) 1/EJ = b/EJ$$

$$L_{FE}^{xx} = \int_0^b (1) 1/EJ dx = [x]_0^b 1/EJ$$

$$= (b) 1/EJ = b/EJ$$

$$L_{FC}^{xx} = \int_0^b (1 - 2x/b + x^2/b^2) 1/EJ dx = [x - x^2/b + 1/3 x^3/b^2]_0^b 1/EJ$$

$$= (b - b + 1/3 b) 1/EJ = 1/3 b/EJ$$

$$L_{CF}^{xx} = \int_0^b (x^2/b^2) 1/EJ dx = [1/3 x^3/b^2]_0^b 1/EJ$$

$$= (1/3 b) 1/EJ = 1/3 b/EJ$$

$$L_{EF}^{xo} = \int_0^b (-5/2 x/b) Fb 1/EJ dx + \int_0^b (1) \theta dx = [-5/4 x^2/b]_0^b Fb 1/EJ + [x]_0^b \theta$$

$$= (-5/4 b) Fb 1/EJ + (b) \theta = -1/4 Fb^2/EJ$$

$$L_{FE}^{xo} = \int_0^b (-5/2 + 5/2 x/b) Fb 1/EJ dx + \int_0^b (-1) \theta dx = [-5/2 x + 5/4 x^2/b]_0^b Fb 1/EJ + [-x]_0^b \theta$$

$$= (-5/2 b + 5/4 b) Fb 1/EJ + (-b) \theta = -1/4 Fb^2/EJ$$

$$L_{FC}^{xo} = \int_0^b (-5/2 + 5x/b - 5/2 x^2/b^2) Fb 1/EJ dx = [-5/2 x + 5/2 x^2/b - 5/6 x^3/b^2]_0^b Fb 1/EJ$$

$$= (-5/2 b + 5/2 b - 5/6 b) Fb 1/EJ = -5/6 Fb^2/EJ$$

$$L_{CF}^{xo} = \int_0^b (-5/2 x^2/b^2) Fb 1/EJ dx = [-5/6 x^3/b^2]_0^b Fb 1/EJ$$

$$= (-5/6 b) Fb 1/EJ = -5/6 Fb^2/EJ$$

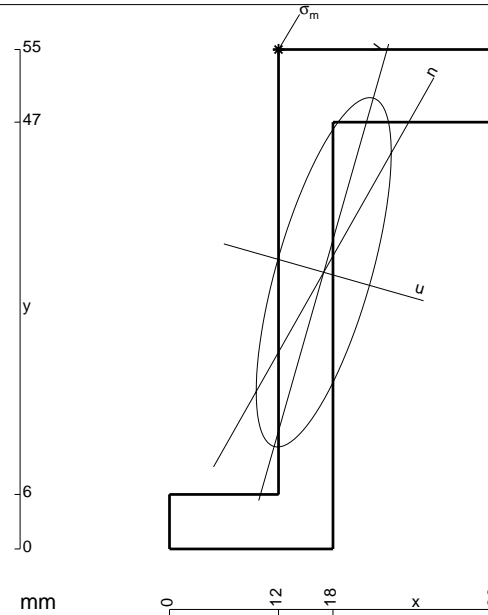

$$A = 546. \text{ mm}^2$$

$$J_x = 202107. \text{ mm}^4$$

$$J_y = 30174. \text{ mm}^4$$

$$J_{xy} = 53280. \text{ mm}^4$$

$$J_u = 217279. \text{ mm}^4$$

$$J_v = 15002. \text{ mm}^4$$

$$\alpha = \text{artg}(2J_{xy}/(J_y - J_x))/2 = -.2774$$

$$c = \cos \alpha = .9618$$

$$s = \sin \alpha = -.2739$$

$$x_g = 16.98 \text{ mm}$$

$$y_g = 30.47 \text{ mm}$$

$$N = -1319. \text{ N}$$

$$T_y = -659.6 \text{ N}$$

$$M_x = 737500. \text{ Nmm}$$

$$x_m = 12. \text{ mm}$$

$$y_m = 55. \text{ mm}$$

$$u_m = -11.51 \text{ mm}$$

$$v_m = 22.23 \text{ mm}$$

$$\sigma_m = N/A - Mcv/J_u - Msu/J_v = -229.9 \text{ N/mm}^2$$

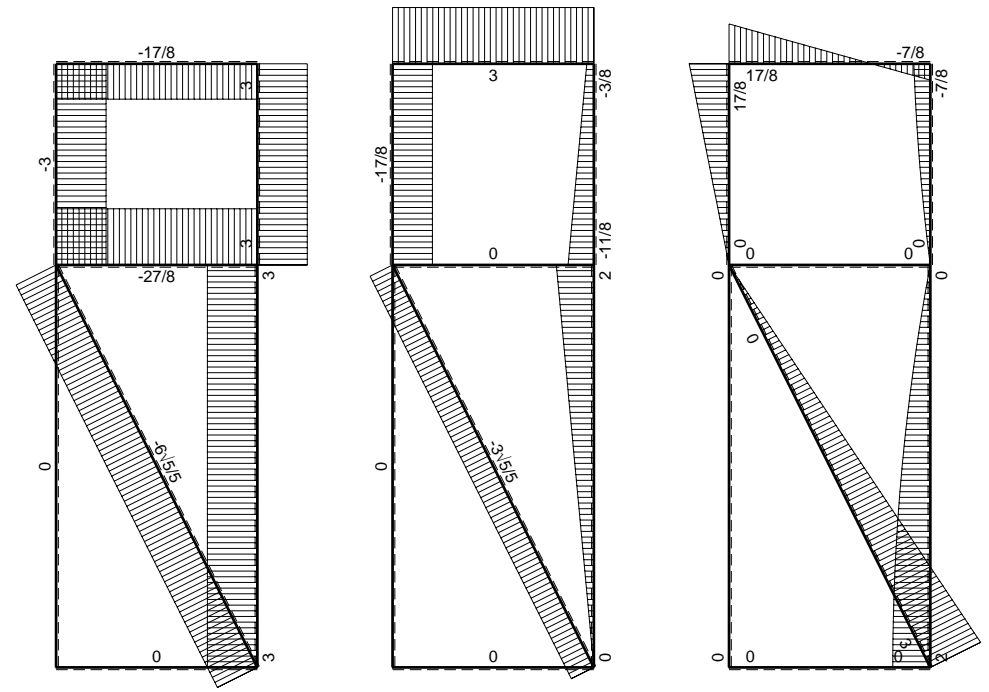
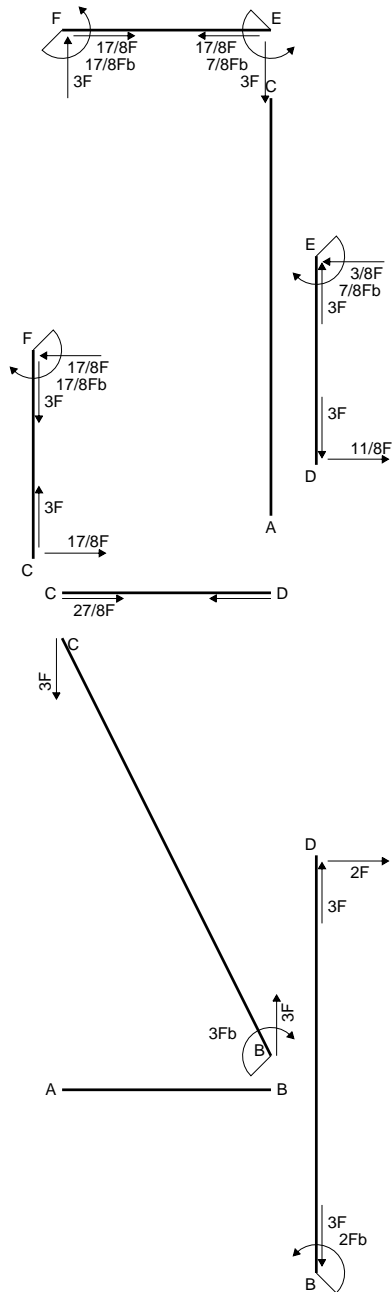

← ⊕ → F

↑ ⊕ ↓ F

⊕ ⊖ F_b

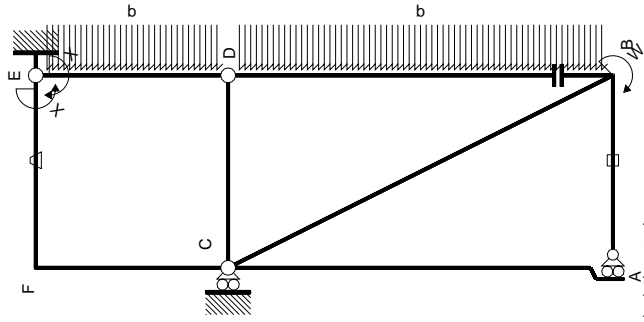

M_0 flessione da carichi assegnati

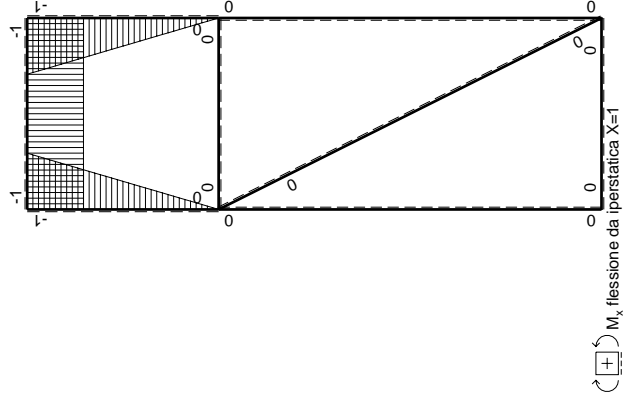

Quadro contributi PLV per iperstatica $X=W_{EF}$

\leftarrow	$M^x(x)$	$M^0(x)$	θ	$M^x M_0$	$M^x \theta$	$M^x M_x$	$\int M^x(M_0/EJ+\theta)dx$	$\int M^x M_x/EJdx$
AB b	0	0	0	0	0	0	0+0	0
BA b	0	0	0	0	0	0	0	0
BC $\sqrt{5}b$	0	$3Fb-3\sqrt{5}/5Fx$	0	0	0	0	0+0	0
CA 2b	0	0	0	0	0	0	0+0	0
DB 2b	0	$2Fx-1/2qx^2$	0	0	0	0	0+0	0
BD 2b	0	$-2Fb+1/2qx^2$	0	0	0	0	0+0	0
DE b	$-x/b$	$-1/2Fx+1/2qx^2$	0	$1/2Fx^2/b-1/2qx^3/b$	0	0	x^2/b^2	$1/3Xb/EJ$
ED b	$1-x/b$	$1/2Fx-1/2qx^2$	0	$1/2Fx-Fx^2/b+1/2qx^3/b$	0	0	$1-2x/b+x^2/b^2$	$1/3Xb/EJ$
CD b	0	0	0	0	0	0	0+0	0
DC b	0	0	0	0	0	0	0+0	0
EF b	-1	$3Fx$	$-Fb/EJ$	$-3Fx$	Fb/EJ	1	$(-3/2+1)Fb^2/EJ$	Xb/EJ
FE b	1	$-3Fb+3Fx$	Fb/EJ	$-3Fb+3Fx$	Fb/EJ	1	$(-3/2+1)Fb^2/EJ$	Xb/EJ
FC b	$-1+x/b$	$3Fb-3Fx$	0	$-3Fb+6Fx-3Fx^2/b$	0	0	$1-2x/b+x^2/b^2$	$1/3Xb/EJ$
CF b	x/b	$-3Fx$	0	$-3Fx^2/b$	0	0	x^2/b^2	$1/3Xb/EJ$
totali							$-35/24Fb^2/EJ$	$5/3Xb/EJ$
							$7/8Fb$	

Sviluppi di calcolo iperstatica

$$L_{DE}^{xx} = \int_0^b (x^2/b^2) 1/EJ dx = [1/3 x^3/b^2]_0^b 1/EJ$$

$$= (1/3 b) 1/EJ = 1/3 b/EJ$$

$$L_{ED}^{xx} = \int_0^b (1 - 2x/b + x^2/b^2) 1/EJ dx = [x - x^2/b + 1/3 x^3/b^2]_0^b 1/EJ$$

$$= (b - b + 1/3 b) 1/EJ = 1/3 b/EJ$$

$$L_{EF}^{xx} = \int_0^b (1) 1/EJ dx = [x]_0^b 1/EJ$$

$$= (b) 1/EJ = b/EJ$$

$$L_{FE}^{xx} = \int_0^b (1) 1/EJ dx = [x]_0^b 1/EJ$$

$$= (b) 1/EJ = b/EJ$$

$$L_{FC}^{xx} = \int_0^b (1 - 2x/b + x^2/b^2) 1/EJ dx = [x - x^2/b + 1/3 x^3/b^2]_0^b 1/EJ$$

$$= (b - b + 1/3 b) 1/EJ = 1/3 b/EJ$$

$$L_{CF}^{xx} = \int_0^b (x^2/b^2) 1/EJ dx = [1/3 x^3/b^2]_0^b 1/EJ$$

$$= (1/3 b) 1/EJ = 1/3 b/EJ$$

$$L_{DE}^{xo} = \int_0^b (1/2 x^2/b^2 - 1/2 x^3/b^3) Fb 1/EJ dx = [1/6 x^3/b^2 - 1/8 x^4/b^3]_0^b Fb 1/EJ$$

$$= (1/6 b - 1/8 b) Fb 1/EJ = 1/24 Fb^2/EJ$$

$$L_{ED}^{xo} = \int_0^b (1/2 x/b - x^2/b^2 + 1/2 x^3/b^3) Fb 1/EJ dx = [1/4 x^2/b - 1/3 x^3/b^2 + 1/8 x^4/b^3]_0^b Fb 1/EJ$$

$$= (1/4 b - 1/3 b + 1/8 b) Fb 1/EJ = 1/24 Fb^2/EJ$$

$$L_{EF}^{xo} = \int_0^b (-3x/b) Fb 1/EJ dx + \int_0^b (1) \theta dx = [-3/2 x^2/b]_0^b Fb 1/EJ + [x]_0^b \theta$$

$$= (-3/2 b) Fb 1/EJ + (b) \theta = -1/2 Fb^2/EJ$$

$$L_{FE}^{xo} = \int_0^b (-3 + 3x/b) Fb 1/EJ dx + \int_0^b (-1) \theta dx = [-3x + 3/2 x^2/b]_0^b Fb 1/EJ + [-x]_0^b \theta$$

$$= (-3b + 3/2 b) Fb 1/EJ + (-b) \theta = -1/2 Fb^2/EJ$$

$$L_{FC}^{xo} = \int_0^b (-3 + 6x/b - 3x^2/b^2) Fb 1/EJ dx = [-3x + 3x^2/b - x^3/b^2]_0^b Fb 1/EJ$$

$$= (-3b + 3b - b) Fb 1/EJ = - Fb^2/EJ$$

$$L_{CF}^{xo} = \int_0^b (-3x^2/b^2) Fb 1/EJ dx = [-x^3/b^2]_0^b Fb 1/EJ$$

$$= (-b) Fb 1/EJ = - Fb^2/EJ$$

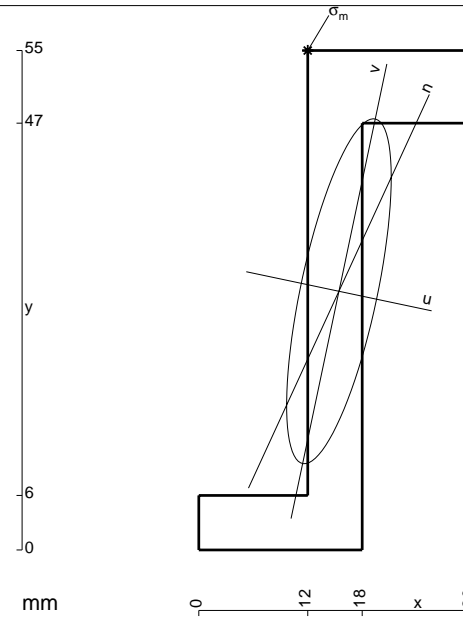

- A = 498. mm²
- J_x = 179663. mm⁴
- J_y = 16520. mm⁴
- J_{xy} = 35967. mm⁴
- J_u = 187241. mm⁴
- J_v = 8943. mm⁴
- α = arctg(2J_{xy}/(J_y-J_x))/2 = -.2076
- c = cosα = .9785
- s = sinα = -.2061
- x_g = 15.43 mm
- y_g = 28.49 mm
- N = -1154. N
- T_y = -576.9 N
- M_x = 696600. Nmm
- x_m = 12. mm
- y_m = 55. mm
- u_m = -8.825 mm
- v_m = 25.23 mm
- σ_m = N/A - Mcv/J_v - Msu/J_u = -235.9 N/mm²

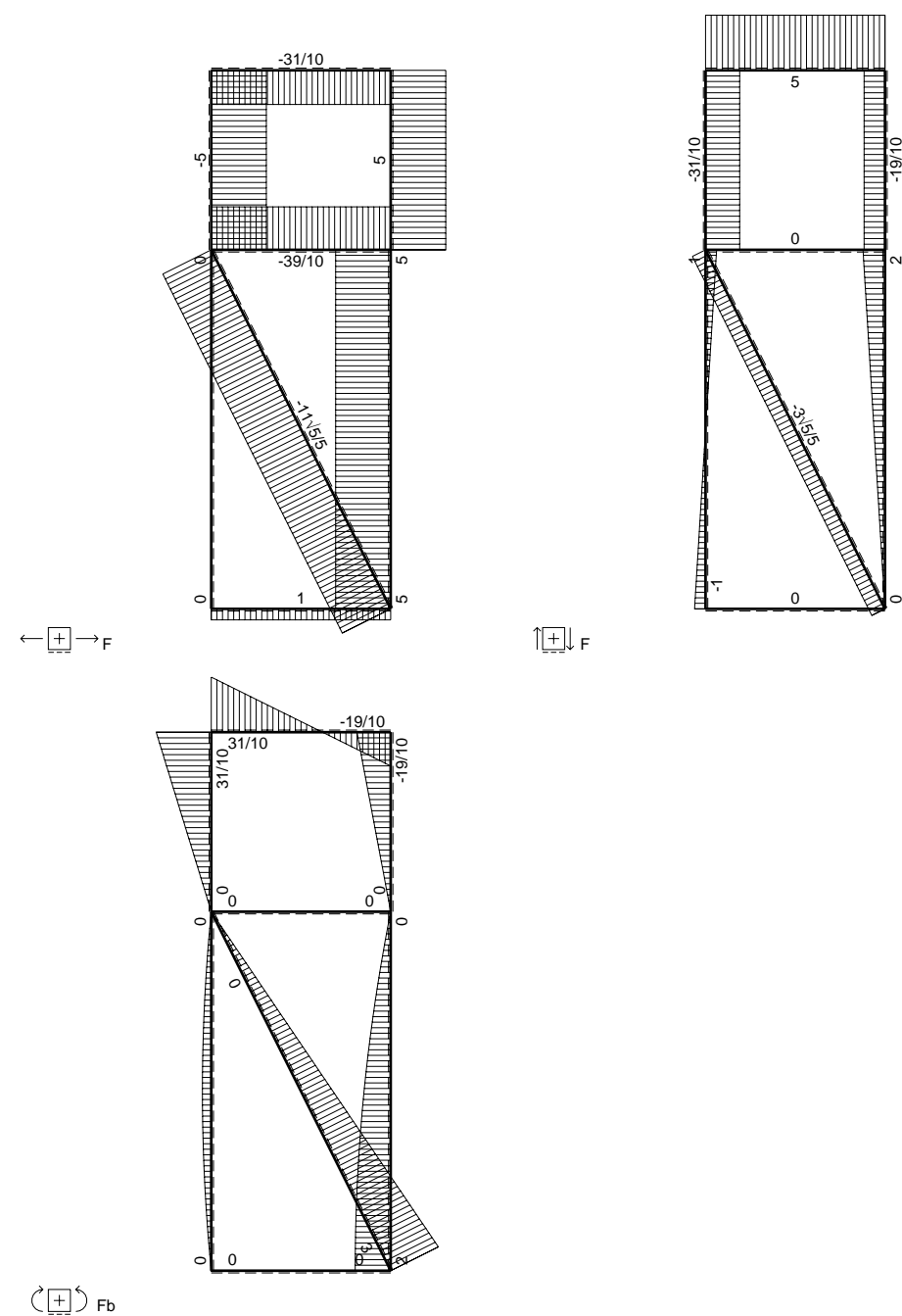
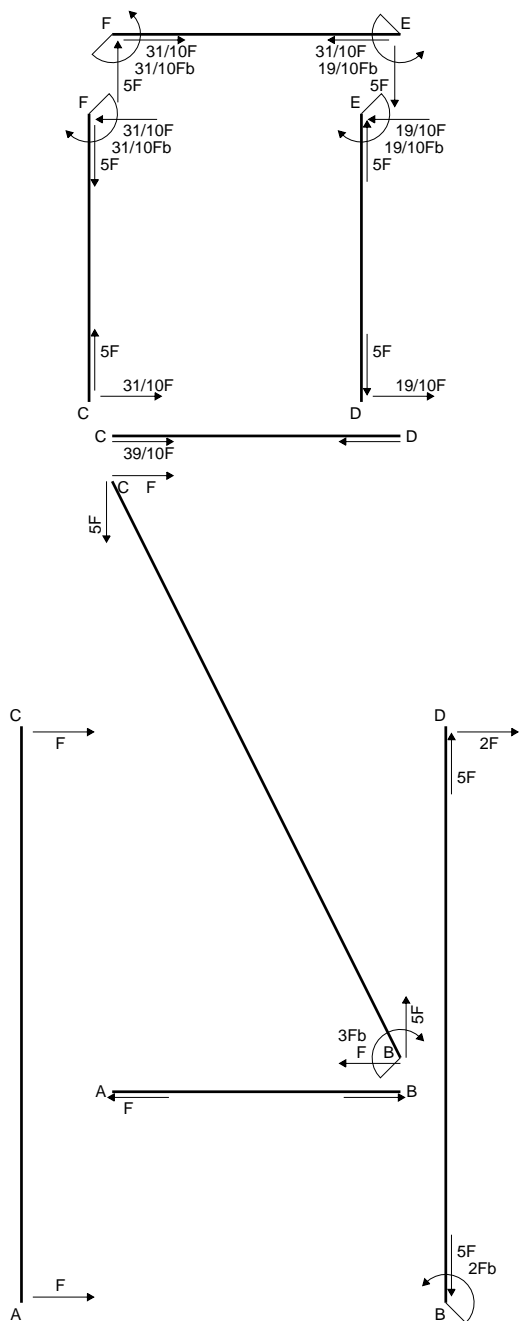

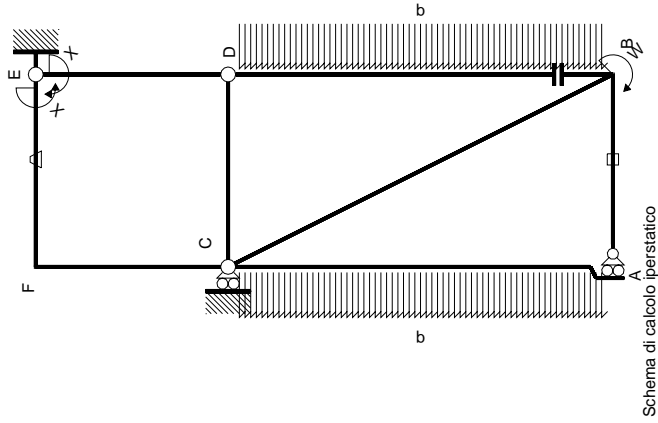

M_0 flessione da carichi assegnati

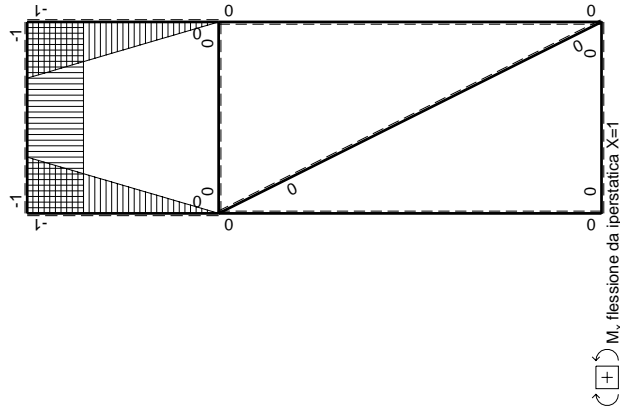

Quadro contributi PLV per iperstatica $X=W_{Ef}$

\rightarrow	$M^x(x)$	$M^0(x)$	θ	$M^x M_0$	$M^x \theta$	$M^x M_x$	$\int M^x (M_0/EJ + \theta) dx$	$\int M^x M_x / E J dx$
AB b	0	0	0	0	0	0	0	0
BA b	0	0	0	0	0	0	0	0
BC $\sqrt{5}b$	0	$3Fb-3\sqrt{5}/5Fx$	0	0	0	0	0	0
CA 2b	0	$-Fx+1/2qx^2$	0	0	0	0	0	0
DB 2b	0	$2Fx-1/2qx^2$	0	0	0	0	0	0
BD 2b	0	$-2Fb+1/2qx^2$	0	0	0	0	0	0
DE b	$-x/b$	0	0	0	0	x^2/b^2	0	$1/3Xb/EJ$
ED b	$1-x/b$	0	0	0	0	$1-2x/b+x^2/b^2$	0	$1/3Xb/EJ$
CD b	0	0	0	0	0	0	0	0
DC b	0	0	0	0	0	0	0	0
EF b	-1	$5Fx$	$-Fb/EJ$	$-5Fx$	Fb/EJ	1	$(-5/2+1)Fb^2/EJ$	Xb/EJ
FE b	1	$-5Fb+5Fx$	Fb/EJ	$-5Fb+5Fx$	Fb/EJ	1	$(-5/2+1)Fb^2/EJ$	Xb/EJ
FC b	$-1+x/b$	$5Fb-5Fx$	0	$-5Fb+10Fx-5Fx^2/b$	0	$1-2x/b+x^2/b^2$	$(-5/3+0)Fb^2/EJ$	$1/3Xb/EJ$
CF b	x/b	$-5Fx$	0	$-5Fx^2/b$	0	x^2/b^2	$-19/6Fb^2/EJ$	$5/3Xb/EJ$
totali								
								$19/10Fb$

Sviluppi di calcolo iperstatica

$$L_{DE}^{xx} = \int_0^b (x^2/b^2) 1/EJ dx = [1/3 x^3/b^2]_0^b 1/EJ$$

$$= (1/3 b) 1/EJ = 1/3 b/EJ$$

$$L_{ED}^{xx} = \int_0^b (1 - 2x/b + x^2/b^2) 1/EJ dx = [x - x^2/b + 1/3 x^3/b^2]_0^b 1/EJ$$

$$= (b - b + 1/3 b) 1/EJ = 1/3 b/EJ$$

$$L_{EF}^{xx} = \int_0^b (1) 1/EJ dx = [x]_0^b 1/EJ$$

$$= (b) 1/EJ = b/EJ$$

$$L_{FE}^{xx} = \int_0^b (1) 1/EJ dx = [x]_0^b 1/EJ$$

$$= (b) 1/EJ = b/EJ$$

$$L_{FC}^{xx} = \int_0^b (1 - 2x/b + x^2/b^2) 1/EJ dx = [x - x^2/b + 1/3 x^3/b^2]_0^b 1/EJ$$

$$= (b - b + 1/3 b) 1/EJ = 1/3 b/EJ$$

$$L_{CF}^{xx} = \int_0^b (x^2/b^2) 1/EJ dx = [1/3 x^3/b^2]_0^b 1/EJ$$

$$= (1/3 b) 1/EJ = 1/3 b/EJ$$

$$L_{EF}^{xo} = \int_0^b (-5x/b) Fb 1/EJ dx + \int_0^b (1) \theta dx = [-5/2 x^2/b]_0^b Fb 1/EJ + [x]_0^b \theta$$

$$= (-5/2 b) Fb 1/EJ + (b) \theta = -3/2 Fb^2/EJ$$

$$L_{FE}^{xo} = \int_0^b (-5 + 5x/b) Fb 1/EJ dx + \int_0^b (-1) \theta dx = [-5x + 5/2 x^2/b]_0^b Fb 1/EJ + [-x]_0^b \theta$$

$$= (-5b + 5/2 b) Fb 1/EJ + (-b) \theta = -3/2 Fb^2/EJ$$

$$L_{FC}^{xo} = \int_0^b (-5 + 10x/b - 5x^2/b^2) Fb 1/EJ dx = [-5x + 5x^2/b - 5/3 x^3/b^2]_0^b Fb 1/EJ$$

$$= (-5b + 5b - 5/3 b) Fb 1/EJ = -5/3 Fb^2/EJ$$

$$L_{CF}^{xo} = \int_0^b (-5x^2/b^2) Fb 1/EJ dx = [-5/3 x^3/b^2]_0^b Fb 1/EJ$$

$$= (-5/3 b) Fb 1/EJ = -5/3 Fb^2/EJ$$

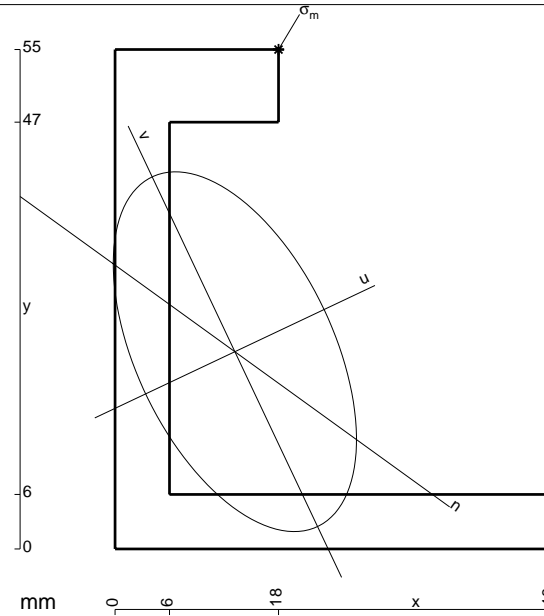

- A = 678. mm²
- J_x = 266093. mm⁴
- J_y = 121648. mm⁴
- J_{xy} = -87929. mm⁴
- J_u = 307658. mm⁴
- J_v = 80083. mm⁴
- α = arctg(2J_{xy}/(J_y-J_x))/2 = .4416
- c = cosα = .9041
- s = sinα = .4274
- x_g = 13.19 mm
- y_g = 21.72 mm
- N = -2950. N
- T_y = -1829. N
- M_x = 1060820. Nmm
- x_m = 18. mm
- y_m = 55. mm
- u_m = 18.57 mm
- v_m = 28.03 mm
- σ_m = N/A - Mcv/J_v - Msu/J_u = -196.8 N/mm²

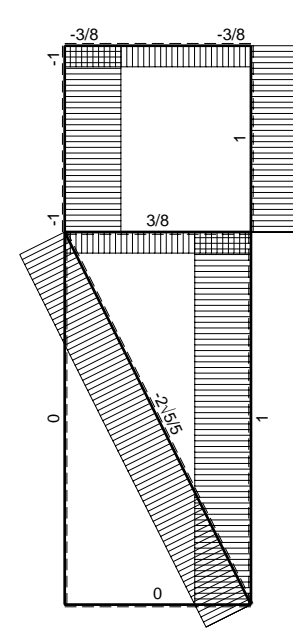
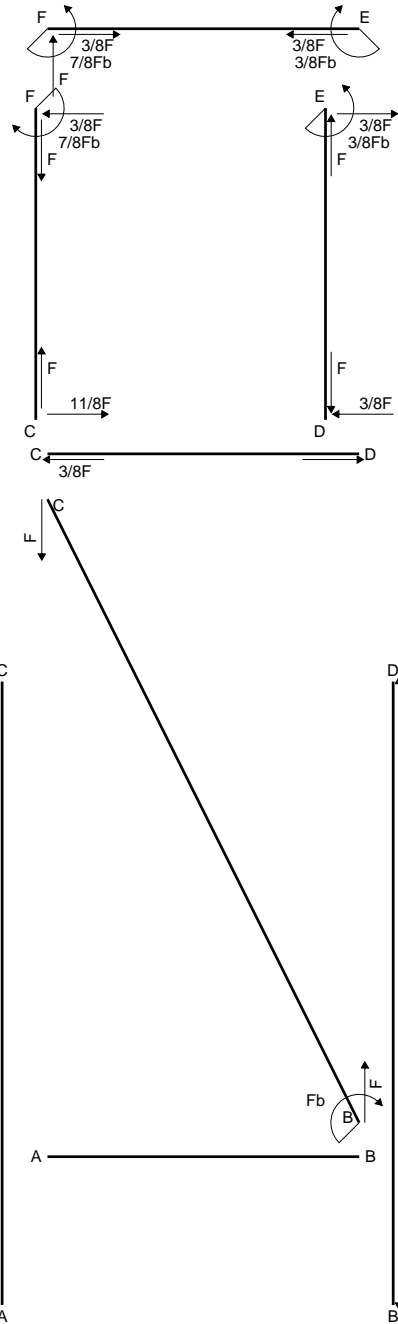

← ⊕ → F

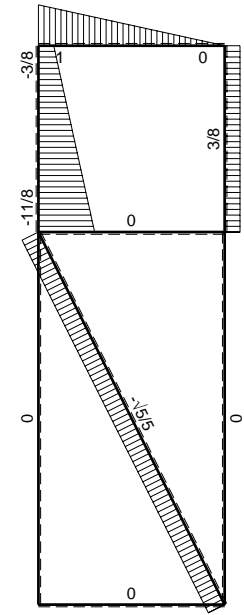

↑ ⊕ ↓ F

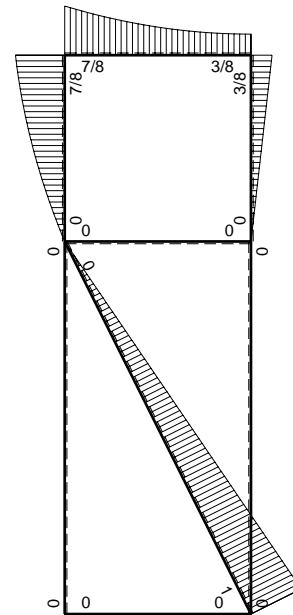

⊕ ↻ F_b

$$L_{DE}^{xx} = \int_0^b (x^2/b^2) 1/EJ dx = [1/3 x^3/b^2]_0^b 1/EJ$$

$$= (1/3 b) 1/EJ = 1/3 b/EJ$$

$$L_{ED}^{xx} = \int_0^b (1 - 2x/b + x^2/b^2) 1/EJ dx = [x - x^2/b + 1/3 x^3/b^2]_0^b 1/EJ$$

$$= (b - b + 1/3 b) 1/EJ = 1/3 b/EJ$$

$$L_{EF}^{xx} = \int_0^b (1) 1/EJ dx = [x]_0^b 1/EJ$$

$$= (b) 1/EJ = b/EJ$$

$$L_{FE}^{xx} = \int_0^b (1) 1/EJ dx = [x]_0^b 1/EJ$$

$$= (b) 1/EJ = b/EJ$$

$$L_{FC}^{xx} = \int_0^b (1 - 2x/b + x^2/b^2) 1/EJ dx = [x - x^2/b + 1/3 x^3/b^2]_0^b 1/EJ$$

$$= (b - b + 1/3 b) 1/EJ = 1/3 b/EJ$$

$$L_{CF}^{xx} = \int_0^b (x^2/b^2) 1/EJ dx = [1/3 x^3/b^2]_0^b 1/EJ$$

$$= (1/3 b) 1/EJ = 1/3 b/EJ$$

$$L_{EF}^{xo} = \int_0^b (-1/2 x^2/b^2) Fb 1/EJ dx + \int_0^b (1) \theta dx = [-1/6 x^3/b^2]_0^b Fb 1/EJ + [x]_0^b \theta$$

$$= (-1/6 b) Fb 1/EJ + (b) \theta = 5/6 Fb^2/EJ$$

$$L_{FE}^{xo} = \int_0^b (-1/2 + x/b - 1/2 x^2/b^2) Fb 1/EJ dx + \int_0^b (-1) \theta dx$$

$$= [-1/2 x + 1/2 x^2/b - 1/6 x^3/b^2]_0^b Fb 1/EJ + [-x]_0^b \theta$$

$$= (-1/2 b + 1/2 b - 1/6 b) Fb 1/EJ + (-b) \theta = 5/6 Fb^2/EJ$$

$$L_{FC}^{xo} = \int_0^b (-1/2 + 1/2 x/b + 1/2 x^2/b^2 - 1/2 x^3/b^3) Fb 1/EJ dx$$

$$= [-1/2 x + 1/4 x^2/b + 1/6 x^3/b^2 - 1/8 x^4/b^3]_0^b Fb 1/EJ$$

$$= (-1/2 b + 1/4 b + 1/6 b - 1/8 b) Fb 1/EJ = -5/24 Fb^2/EJ$$

$$L_{CF}^{xo} = \int_0^b (-x^2/b^2 + 1/2 x^3/b^3) Fb 1/EJ dx = [-1/3 x^3/b^2 + 1/8 x^4/b^3]_0^b Fb 1/EJ$$

$$= (-1/3 b + 1/8 b) Fb 1/EJ = -5/24 Fb^2/EJ$$

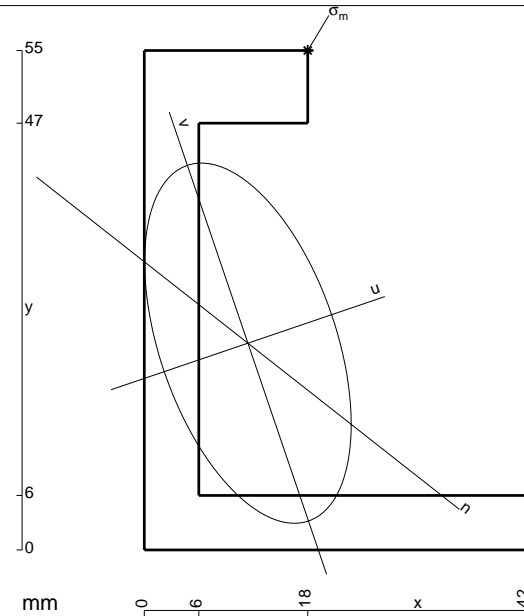

$$A = 642. \text{ mm}^2$$

$$J_x = 252660. \text{ mm}^4$$

$$J_y = 83081. \text{ mm}^4$$

$$J_{xy} = -65292. \text{ mm}^4$$

$$J_u = 274886. \text{ mm}^4$$

$$J_v = 60856. \text{ mm}^4$$

$$\alpha = \text{artg}(2J_{xy}/(J_y - J_x))/2 = .3281$$

$$c = \cos \alpha = .9467$$

$$s = \sin \alpha = .3222$$

$$x_g = 11.41 \text{ mm}$$

$$y_g = 22.77 \text{ mm}$$

$$N = -1610. \text{ N}$$

$$T_y = -805. \text{ N}$$

$$M_x = 1116000. \text{ Nmm}$$

$$x_m = 18. \text{ mm}$$

$$y_m = 55. \text{ mm}$$

$$u_m = 16.62 \text{ mm}$$

$$v_m = 28.39 \text{ mm}$$

$$\sigma_m = N/A - Mcv/J_u - Msu/J_v = -209.8 \text{ N/mm}^2$$

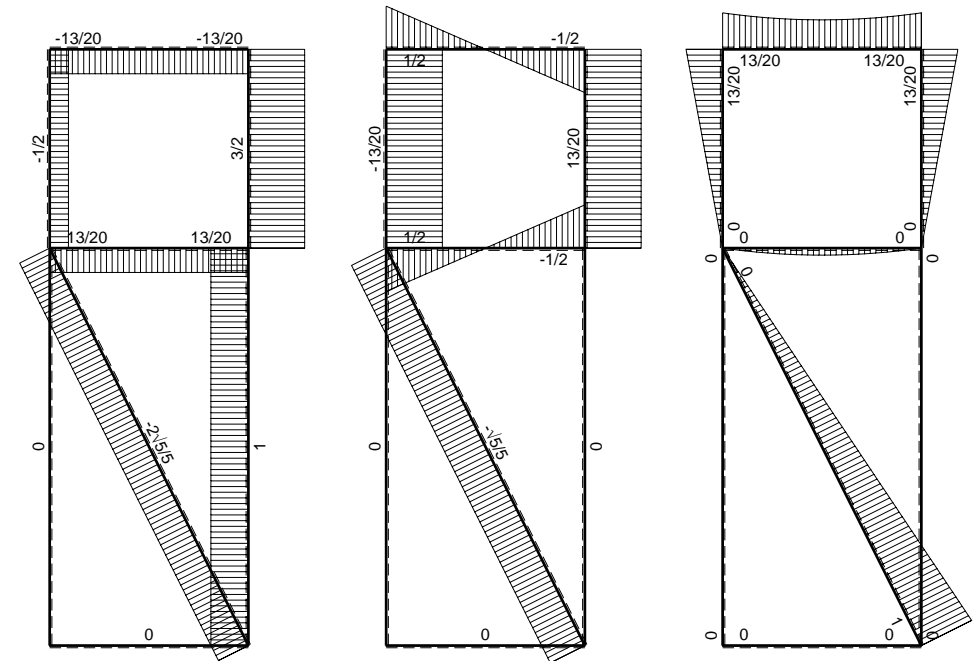
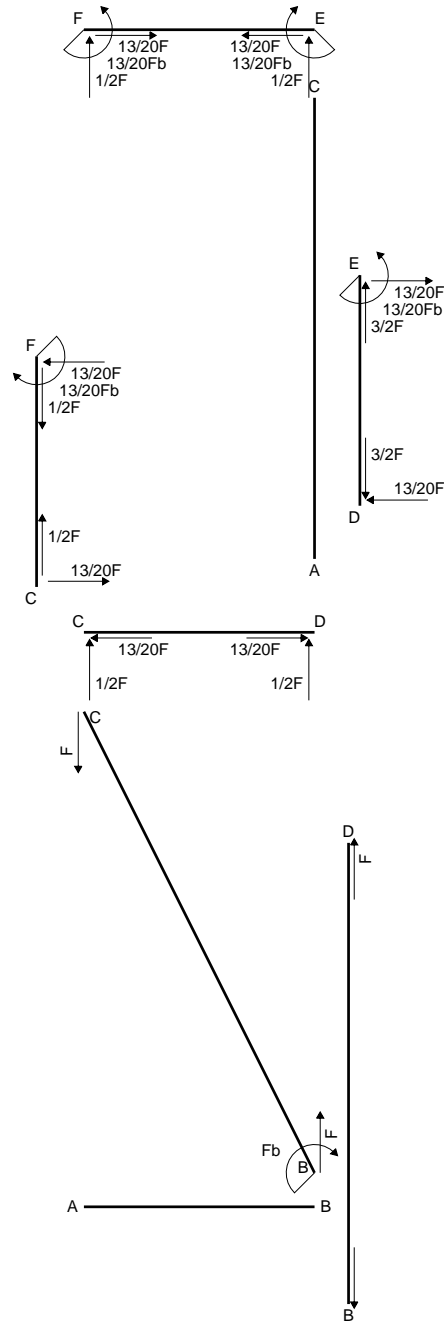

← ⊕ → F

↑ ⊕ ↓ F

⊕ ⊖ F_b

$$L_{DE}^{xx} = \int_0^b (x^2/b^2) 1/EJ dx = [1/3 x^3/b^2]_0^b 1/EJ$$

$$= (1/3 b) 1/EJ = 1/3 b/EJ$$

$$L_{ED}^{xx} = \int_0^b (1 - 2x/b + x^2/b^2) 1/EJ dx = [x - x^2/b + 1/3 x^3/b^2]_0^b 1/EJ$$

$$= (b - b + 1/3 b) 1/EJ = 1/3 b/EJ$$

$$L_{EF}^{xx} = \int_0^b (1) 1/EJ dx = [x]_0^b 1/EJ$$

$$= (b) 1/EJ = b/EJ$$

$$L_{FE}^{xx} = \int_0^b (1) 1/EJ dx = [x]_0^b 1/EJ$$

$$= (b) 1/EJ = b/EJ$$

$$L_{FC}^{xx} = \int_0^b (1 - 2x/b + x^2/b^2) 1/EJ dx = [x - x^2/b + 1/3 x^3/b^2]_0^b 1/EJ$$

$$= (b - b + 1/3 b) 1/EJ = 1/3 b/EJ$$

$$L_{CF}^{xx} = \int_0^b (x^2/b^2) 1/EJ dx = [1/3 x^3/b^2]_0^b 1/EJ$$

$$= (1/3 b) 1/EJ = 1/3 b/EJ$$

$$L_{EF}^{x\theta} = \int_0^b (1/2 x/b - 1/2 x^2/b^2) Fb 1/EJ dx + \int_0^b (1) \theta dx = [1/4 x^2/b - 1/6 x^3/b^2]_0^b Fb 1/EJ + [x]_0^b \theta$$

$$= (1/4 b - 1/6 b) Fb 1/EJ + (b) \theta = 13/12 Fb^2/EJ$$

$$L_{FE}^{x\theta} = \int_0^b (1/2 x/b - 1/2 x^2/b^2) Fb 1/EJ dx + \int_0^b (-1) \theta dx = [1/4 x^2/b - 1/6 x^3/b^2]_0^b Fb 1/EJ + [-x]_0^b \theta$$

$$= (1/4 b - 1/6 b) Fb 1/EJ + (-b) \theta = 13/12 Fb^2/EJ$$

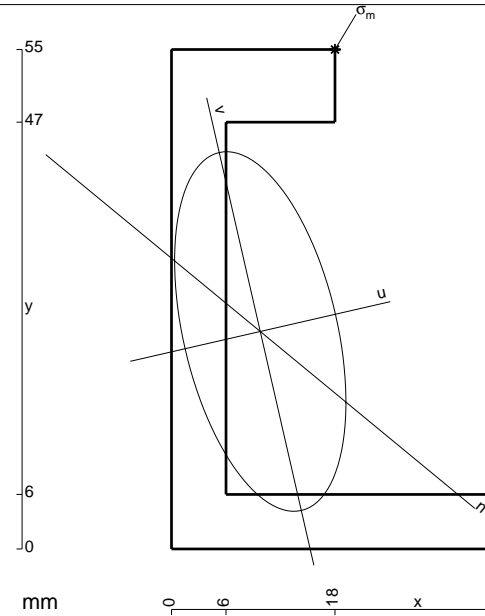

- A = 606. mm²
- J_x = 237644. mm⁴
- J_y = 53945. mm⁴
- J_{xy} = -44489. mm⁴
- J_u = 247851. mm⁴
- J_v = 43738. mm⁴
- α = arctg(2J_{xy}/(J_y-J_x))/2 = .2255
- c = cos α = .9747
- s = sin α = .2236
- x_g = 9.772 mm
- y_g = 23.95 mm
- N = -1556. N
- T_y = -778.2 N
- M_x = 1148400. Nmm
- x_m = 18. mm
- y_m = 55. mm
- u_m = 14.96 mm
- v_m = 28.43 mm
- σ_m = N/A - Mc_v/J_u - Ms_u/J_v = -218.8 N/mm²

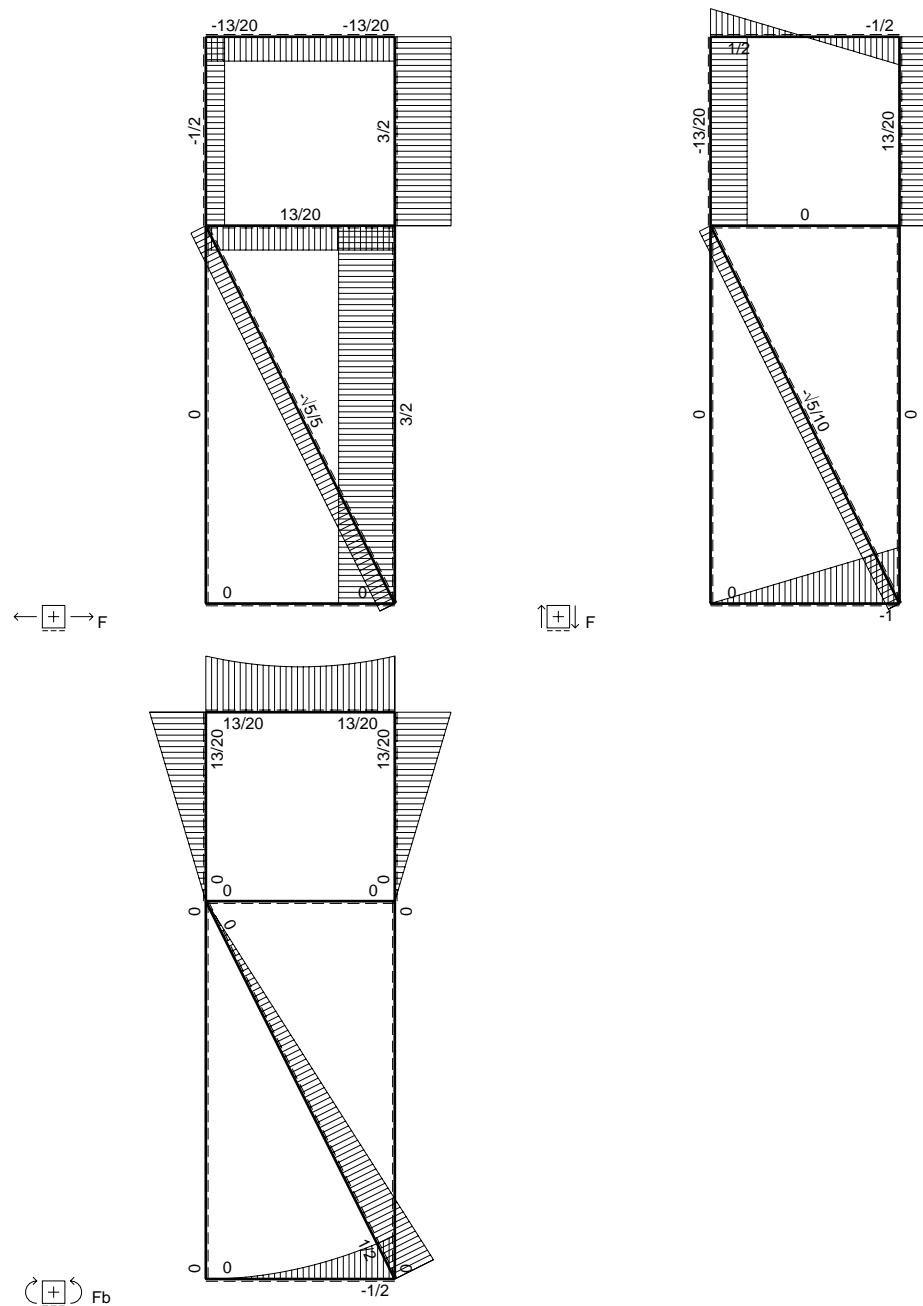
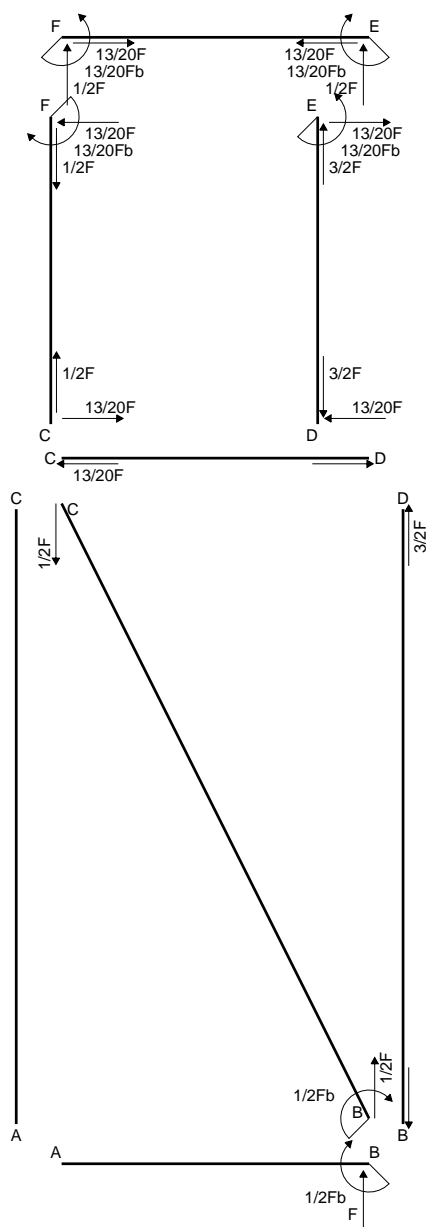

⊕ Fb

$$L_{DE}^{xx} = \int_0^b (x^2/b^2) 1/EJ dx = [1/3 x^3/b^2]_0^b 1/EJ$$

$$= (1/3 b) 1/EJ = 1/3 b/EJ$$

$$L_{ED}^{xx} = \int_0^b (1 - 2x/b + x^2/b^2) 1/EJ dx = [x - x^2/b + 1/3 x^3/b^2]_0^b 1/EJ$$

$$= (b - b + 1/3 b) 1/EJ = 1/3 b/EJ$$

$$L_{EF}^{xx} = \int_0^b (1) 1/EJ dx = [x]_0^b 1/EJ$$

$$= (b) 1/EJ = b/EJ$$

$$L_{FE}^{xx} = \int_0^b (1) 1/EJ dx = [x]_0^b 1/EJ$$

$$= (b) 1/EJ = b/EJ$$

$$L_{FC}^{xx} = \int_0^b (1 - 2x/b + x^2/b^2) 1/EJ dx = [x - x^2/b + 1/3 x^3/b^2]_0^b 1/EJ$$

$$= (b - b + 1/3 b) 1/EJ = 1/3 b/EJ$$

$$L_{CF}^{xx} = \int_0^b (x^2/b^2) 1/EJ dx = [1/3 x^3/b^2]_0^b 1/EJ$$

$$= (1/3 b) 1/EJ = 1/3 b/EJ$$

$$L_{EF}^{x\theta} = \int_0^b (1/2 x/b - 1/2 x^2/b^2) Fb 1/EJ dx + \int_0^b (1) \theta dx = [1/4 x^2/b - 1/6 x^3/b^2]_0^b Fb 1/EJ + [x]_0^b \theta$$

$$= (1/4 b - 1/6 b) Fb 1/EJ + (b) \theta = 13/12 Fb^2/EJ$$

$$L_{FE}^{x\theta} = \int_0^b (1/2 x/b - 1/2 x^2/b^2) Fb 1/EJ dx + \int_0^b (-1) \theta dx = [1/4 x^2/b - 1/6 x^3/b^2]_0^b Fb 1/EJ + [-x]_0^b \theta$$

$$= (1/4 b - 1/6 b) Fb 1/EJ + (-b) \theta = 13/12 Fb^2/EJ$$

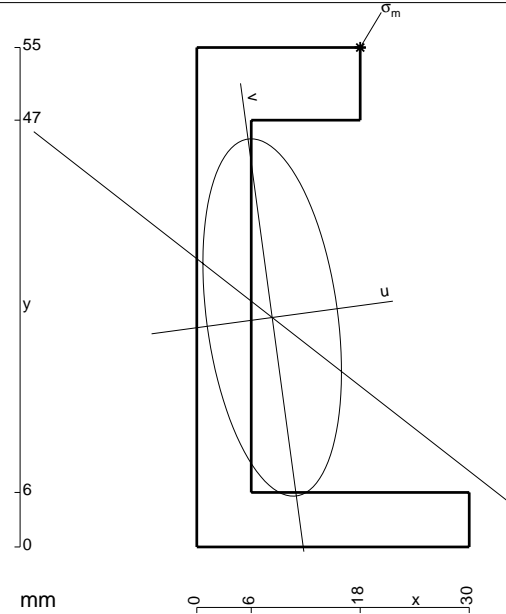

- A = 570. mm²
- J_x = 220745. mm⁴
- J_y = 33187. mm⁴
- J_{xy} = -25868. mm⁴
- J_u = 224247. mm⁴
- J_v = 29685. mm⁴
- α = artg(2J_{xy}/(J_y-J_x))/2 = .1346
- c = cosα = .9910
- s = sinα = .1342
- x_g = 8.305 mm
- y_g = 25.27 mm
- N = -1742. N
- T_y = -1340. N
- M_x = 1219400. Nmm
- x_m = 18. mm
- y_m = 55. mm
- u_m = 13.6 mm
- v_m = 28.16 mm
- σ_m = N/A - Mcv/J_u - Msu/J_v = -229.7 N/mm²

