

$\left[\begin{matrix} + \\ + \end{matrix} \right] F_b$

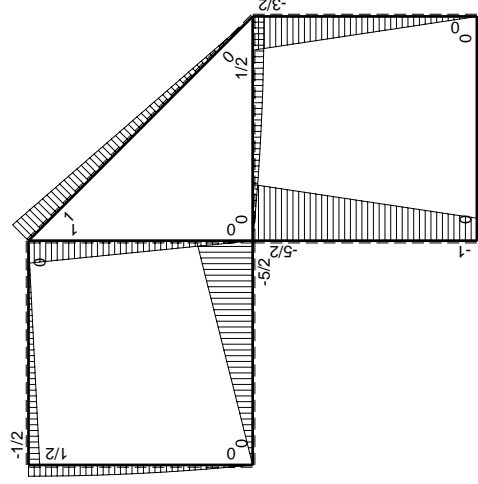

Schema di calcolo iperstatico

M_0 flessione da carichi assegnati

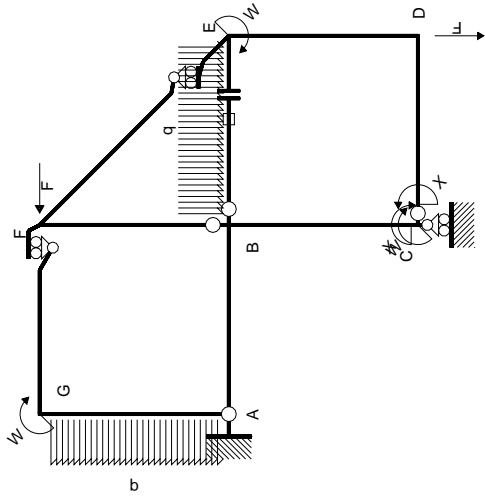
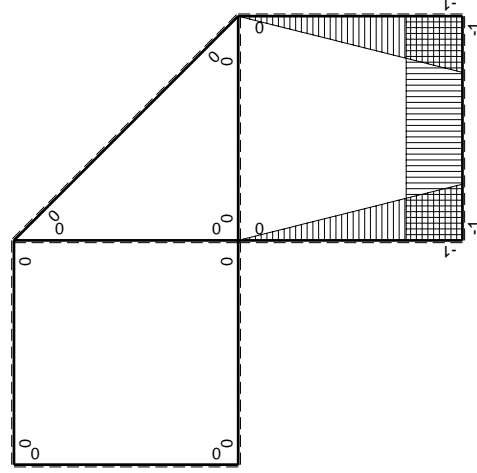

M_x flessione da iperstatica $X=1$

Quadro contribuiti PLV per iperstatica $X=W_{cd}$

\rightarrow	$M_x(x)$	$M_0(x)$	$M_x M_0$	$M_x M_x$	$\int M_x M_0 / EJ dx$	$\int X M_x M_x / EJ dx$
AB b	0	-5/2Fx	0	0	0	0
BA b	0	5/2Fb-5/2Fx	0	0	0	0
BC b	-x/b	-5/2Fb+3/2Fx	5/2Fx-3/2Fx ² /b	x ² /b ²	3/4Fb ² /EJ	1/3Xb/EJ
CB b	1-x/b	Fb+3/2Fx	Fb+1/2Fx-3/2Fx ² /b	1-2x/b+x ² /b ²	0	Xb/EJ
CD b	-1	0	0	1	0	0
DC b	1	0	0	1	0	0
DE b	-1+x/b	-3/2Fx	3/2Fx-3/2Fx ² /b	1-2x/b+x ² /b ²	1/4Fb ² /EJ	1/3Xb/EJ
ED b	x/b	3/2Fb-3/2Fx	3/2Fx-3/2Fx ² /b	x ² /b ²	0	0
EF $\sqrt{2}b$	0	$\sqrt{2}2Fx$	0	0	0	0
FG b	0	-1/2Fx	0	0	0	0
GF b	0	1/2Fb-1/2Fx	0	0	0	0
GA b	0	1/2Fb-1/2qx ²	0	0	0	0
AG b	0	-Fx+1/2qx ²	0	0	0	0
FB b	0	Fb-Fx	0	0	0	0
BF b	0	-Fx	0	0	0	0
BE b	0	Fx-1/2qx ²	0	0	0	0
EB b	0	-1/2Fb+1/2qx ²	0	0	0	0
BE	elongazione asta $N_{1, BE} \epsilon_{BE} = L_{BE}$				Fb ² /EJ	
	totali				2Fb ² /EJ	5/3Xb/EJ
	iperstatica $X=W_{cd}$				-6/5Fb	

Sviluppi di calcolo iperstatica

$$L_{BC}^{xx} = \int_0^b (x^2/b^2) 1/EJ dx = [1/3 x^3/b^2]_0^b 1/EJ$$

$$= (1/3 b) 1/EJ = 1/3 b/EJ$$

$$L_{CB}^{xx} = \int_0^b (1 - 2x/b + x^2/b^2) 1/EJ dx = [x - x^2/b + 1/3 x^3/b^2]_0^b 1/EJ$$

$$= (b - b + 1/3 b) 1/EJ = 1/3 b/EJ$$

$$L_{CD}^{xx} = \int_0^b (1) 1/EJ dx = [x]_0^b 1/EJ$$

$$= (b) 1/EJ = b/EJ$$

$$L_{DC}^{xx} = \int_0^b (1) 1/EJ dx = [x]_0^b 1/EJ$$

$$= (b) 1/EJ = b/EJ$$

$$L_{DE}^{xx} = \int_0^b (1 - 2x/b + x^2/b^2) 1/EJ dx = [x - x^2/b + 1/3 x^3/b^2]_0^b 1/EJ$$

$$= (b - b + 1/3 b) 1/EJ = 1/3 b/EJ$$

$$L_{ED}^{xx} = \int_0^b (x^2/b^2) 1/EJ dx = [1/3 x^3/b^2]_0^b 1/EJ$$

$$= (1/3 b) 1/EJ = 1/3 b/EJ$$

$$L_{BC}^{xo} = \int_0^b (5/2 x/b - 3/2 x^2/b^2) Fb 1/EJ dx = [5/4 x^2/b - 1/2 x^3/b^2]_0^b Fb 1/EJ$$

$$= (5/4 b - 1/2 b) Fb 1/EJ = 3/4 Fb^2/EJ$$

$$L_{CB}^{xo} = \int_0^b (1 + 1/2 x/b - 3/2 x^2/b^2) Fb 1/EJ dx = [x + 1/4 x^2/b - 1/2 x^3/b^2]_0^b Fb 1/EJ$$

$$= (b + 1/4 b - 1/2 b) Fb 1/EJ = 3/4 Fb^2/EJ$$

$$L_{DE}^{xo} = \int_0^b (3/2 x/b - 3/2 x^2/b^2) Fb 1/EJ dx = [3/4 x^2/b - 1/2 x^3/b^2]_0^b Fb 1/EJ$$

$$= (3/4 b - 1/2 b) Fb 1/EJ = 1/4 Fb^2/EJ$$

$$L_{ED}^{xo} = \int_0^b (3/2 x/b - 3/2 x^2/b^2) Fb 1/EJ dx = [3/4 x^2/b - 1/2 x^3/b^2]_0^b Fb 1/EJ$$

$$= (3/4 b - 1/2 b) Fb 1/EJ = 1/4 Fb^2/EJ$$

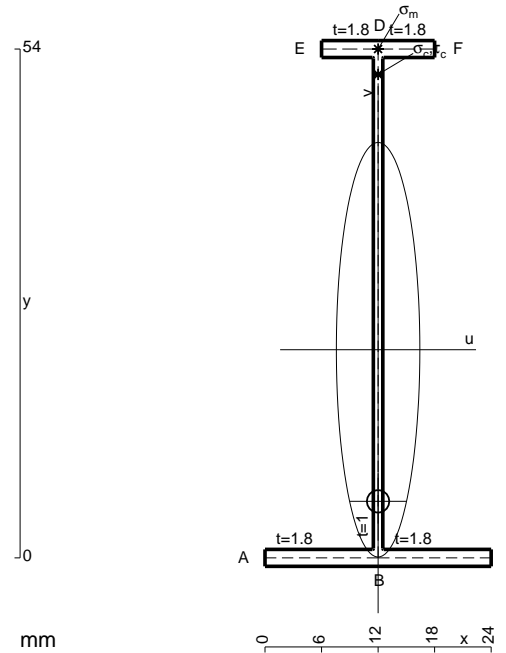

$$A = 118.8 \text{ mm}^2$$

$$J_u = 57498. \text{ mm}^4$$

$$J_v = 2333. \text{ mm}^4$$

$$J_t = 87.98 \text{ mm}^4$$

$$y_o = -16.09 \text{ mm}$$

$$y_g = 22.09 \text{ mm}$$

$$N = -270. \text{ N}$$

$$T_y = -675. \text{ N}$$

$$M_x = -378000. \text{ Nmm}$$

$$x_m = 12. \text{ mm}$$

$$y_m = 54. \text{ mm}$$

$$v_m = 31.91 \text{ mm}$$

$$\sigma_m = N/A - Mv/J_u = 207.5 \text{ N/mm}^2$$

$$y_c = 2. \text{ mm}$$

$$u_c = -12. \text{ mm}$$

$$v_c = -20.09 \text{ mm}$$

$$\sigma_c = N/A - Mv/J_u = 207.5 \text{ N/mm}^2$$

$$\tau_c = TS/tJ_u = 8.091 \text{ N/mm}^2$$

$$\tau_g = TS/tJ_u = 8.091 \text{ N/mm}^2$$

$$t_c = 270. \text{ mm}$$

$$\sigma_o = \sqrt{\sigma^2 + 3\tau^2} = 208. \text{ N/mm}^2$$

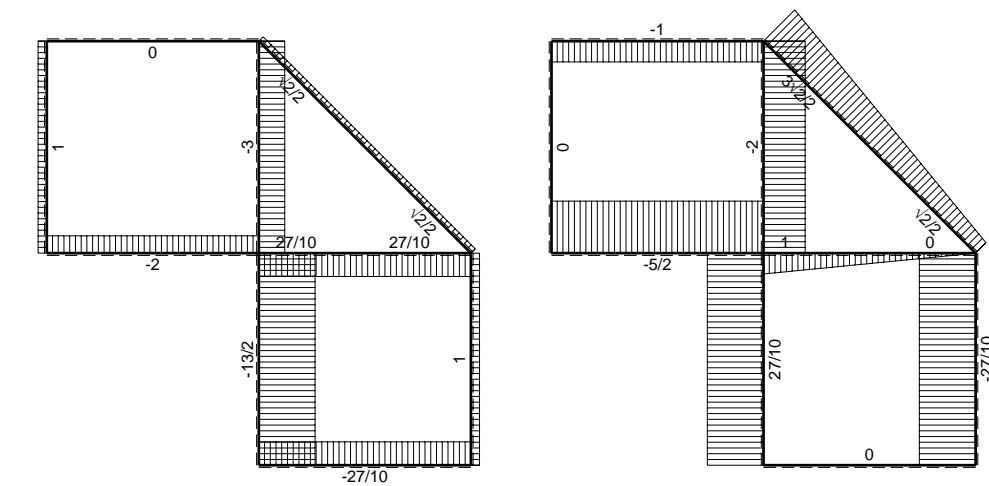
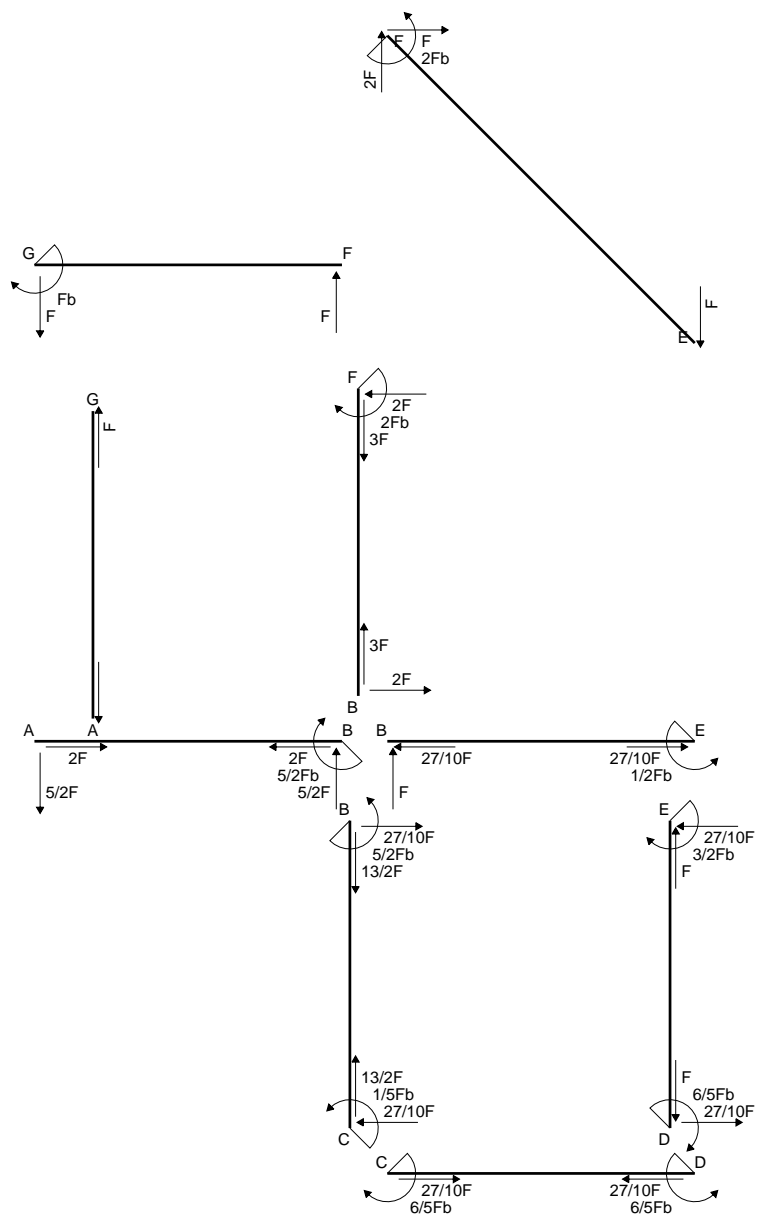

← ⊕ → F

↑ ⊕ ↓ F

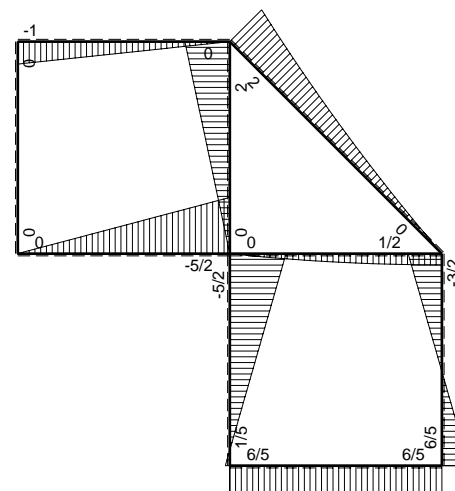

⊕ ⊖ F_b

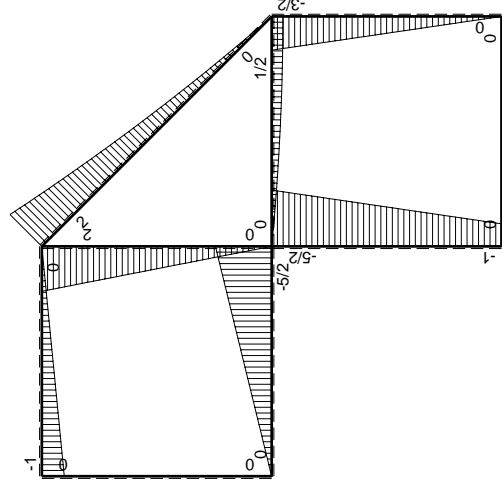
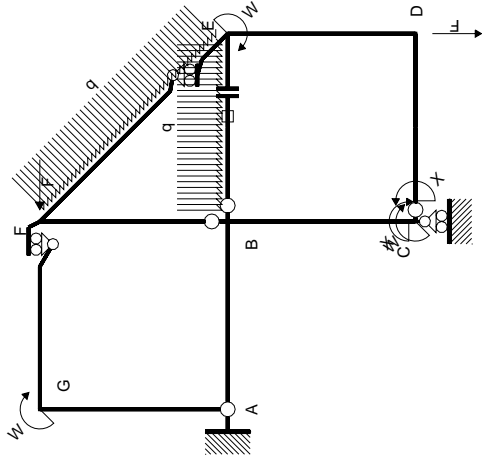

Schema di calcolo iperstatico

M_0 flessione da carichi assegnati

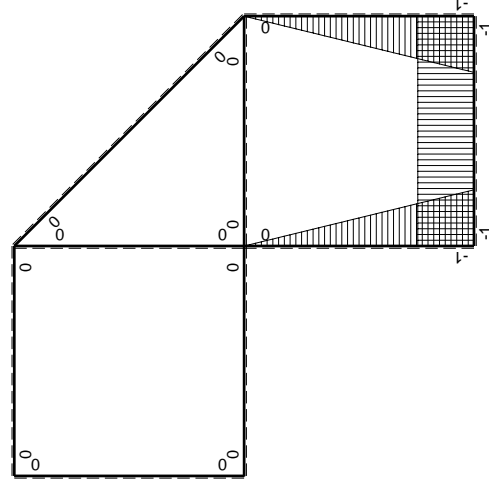

M_x flessione da iperstatica X=1

Quadro contribuiti PLV per iperstatica X=W_{cd}

→	$M_x(x)$	$M_0(x)$	$M_x M_0$	$M_x M_x$	$\int M_x M_0 / EJ dx$	$\int X M_x M_x / EJ dx$
AB b	0	-5/2Fx	0	0	0	0
BA b	0	5/2Fb-5/2Fx	0	0	0	0
BC b	-x/b	-5/2Fb+3/2Fx	5/2Fx-3/2Fx ² /b	x ² /b ²	3/4Fb ² /EJ	1/3Xb/EJ
CB b	1-x/b	Fb+3/2Fx	Fb+1/2Fx-3/2Fx ² /b	1-2x/b+x ² /b ²	0	Xb/EJ
CD b	-1	0	0	1	0	0
DC b	1	0	0	1	0	0
DE b	-1+x/b	-3/2Fx	3/2Fx-3/2Fx ² /b	1-2x/b+x ² /b ²	1/4Fb ² /EJ	1/3Xb/EJ
ED b	x/b	3/2Fb-3/2Fx	3/2Fx-3/2Fx ² /b	x ² /b ²	0	0
EF √2b	0	√2/2Fx+1/2qx ²	0	0	0	0
FG b	0	-Fx	0	0	0	0
GF b	0	Fb-Fx	0	0	0	0
GA b	0	0	0	0	0	0
AG b	0	0	0	0	0	0
FB b	0	2Fb-2Fx	0	0	0	0
BF b	0	-2Fx	0	0	0	0
BE b	0	Fx-1/2qx ²	0	0	0	0
EB b	0	-1/2Fb+1/2qx ²	0	0	0	0
BE	elongazione asta $N_{1, BE} \epsilon_{BE} = L_{BE}$				Fb ² /EJ	
	totali				2Fb ² /EJ	5/3Xb/EJ
	iperstatica X=W _{cd}				-6/5Fb	

Sviluppi di calcolo iperstatica

$$L_{BC}^{xx} = \int_0^b (x^2/b^2) 1/EJ dx = [1/3 x^3/b^2]_0^b 1/EJ$$

$$= (1/3 b) 1/EJ = 1/3 b/EJ$$

$$L_{CB}^{xx} = \int_0^b (1 - 2x/b + x^2/b^2) 1/EJ dx = [x - x^2/b + 1/3 x^3/b^2]_0^b 1/EJ$$

$$= (b - b + 1/3 b) 1/EJ = 1/3 b/EJ$$

$$L_{CD}^{xx} = \int_0^b (1) 1/EJ dx = [x]_0^b 1/EJ$$

$$= (b) 1/EJ = b/EJ$$

$$L_{DC}^{xx} = \int_0^b (1) 1/EJ dx = [x]_0^b 1/EJ$$

$$= (b) 1/EJ = b/EJ$$

$$L_{DE}^{xx} = \int_0^b (1 - 2x/b + x^2/b^2) 1/EJ dx = [x - x^2/b + 1/3 x^3/b^2]_0^b 1/EJ$$

$$= (b - b + 1/3 b) 1/EJ = 1/3 b/EJ$$

$$L_{ED}^{xx} = \int_0^b (x^2/b^2) 1/EJ dx = [1/3 x^3/b^2]_0^b 1/EJ$$

$$= (1/3 b) 1/EJ = 1/3 b/EJ$$

$$L_{BC}^{xo} = \int_0^b (5/2 x/b - 3/2 x^2/b^2) Fb 1/EJ dx = [5/4 x^2/b - 1/2 x^3/b^2]_0^b Fb 1/EJ$$

$$= (5/4 b - 1/2 b) Fb 1/EJ = 3/4 Fb^2/EJ$$

$$L_{CB}^{xo} = \int_0^b (1 + 1/2 x/b - 3/2 x^2/b^2) Fb 1/EJ dx = [x + 1/4 x^2/b - 1/2 x^3/b^2]_0^b Fb 1/EJ$$

$$= (b + 1/4 b - 1/2 b) Fb 1/EJ = 3/4 Fb^2/EJ$$

$$L_{DE}^{xo} = \int_0^b (3/2 x/b - 3/2 x^2/b^2) Fb 1/EJ dx = [3/4 x^2/b - 1/2 x^3/b^2]_0^b Fb 1/EJ$$

$$= (3/4 b - 1/2 b) Fb 1/EJ = 1/4 Fb^2/EJ$$

$$L_{ED}^{xo} = \int_0^b (3/2 x/b - 3/2 x^2/b^2) Fb 1/EJ dx = [3/4 x^2/b - 1/2 x^3/b^2]_0^b Fb 1/EJ$$

$$= (3/4 b - 1/2 b) Fb 1/EJ = 1/4 Fb^2/EJ$$

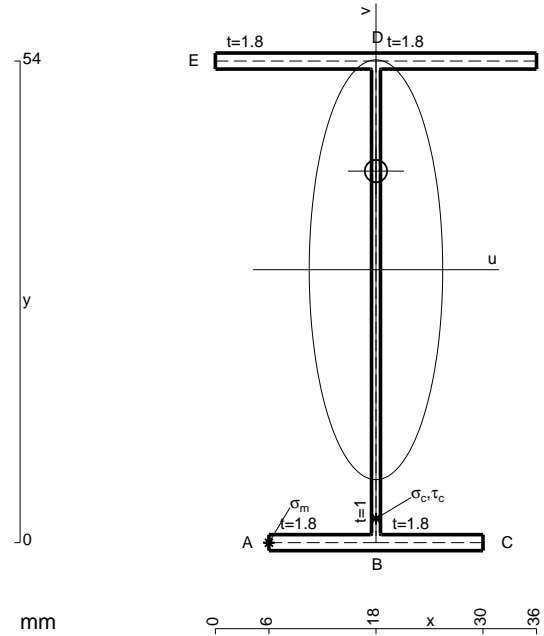

- A = 162. mm²
- J_u = 89755. mm⁴
- J_v = 9072. mm⁴
- J_I = 134.6 mm⁴
- y_o = 11.06 mm
- y_g = 30.6 mm
- N = -820. N
- T_y = -1025. N
- M_x = -625250. Nmm
- x_m = 6. mm
- u_m = -12. mm
- v_m = -30.6 mm
- σ_m = N/A-Mv/J_u = -218.2 N/mm²
- x_c = 18. mm
- v_c = -30.6 mm
- σ_c = N/A-Mv/J_u = -218.2 N/mm²
- τ_c = TS¹/tJ_u = 15.1 N/mm²
- τ_g = TS¹/tJ_u = 15.1 N/mm²
- t_c = 410. mm
- σ_o = √σ²+3τ² = 219.8 N/mm²

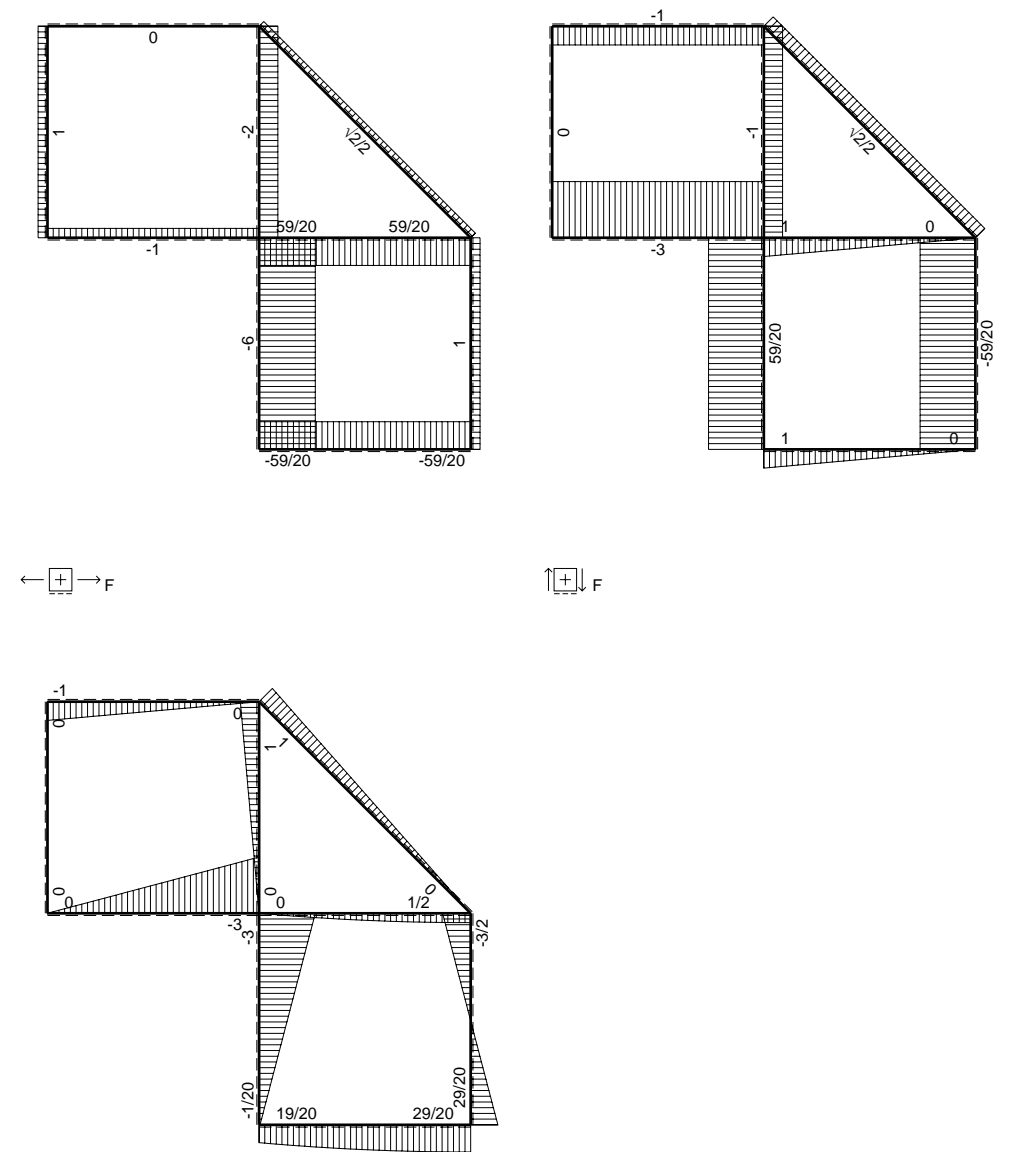
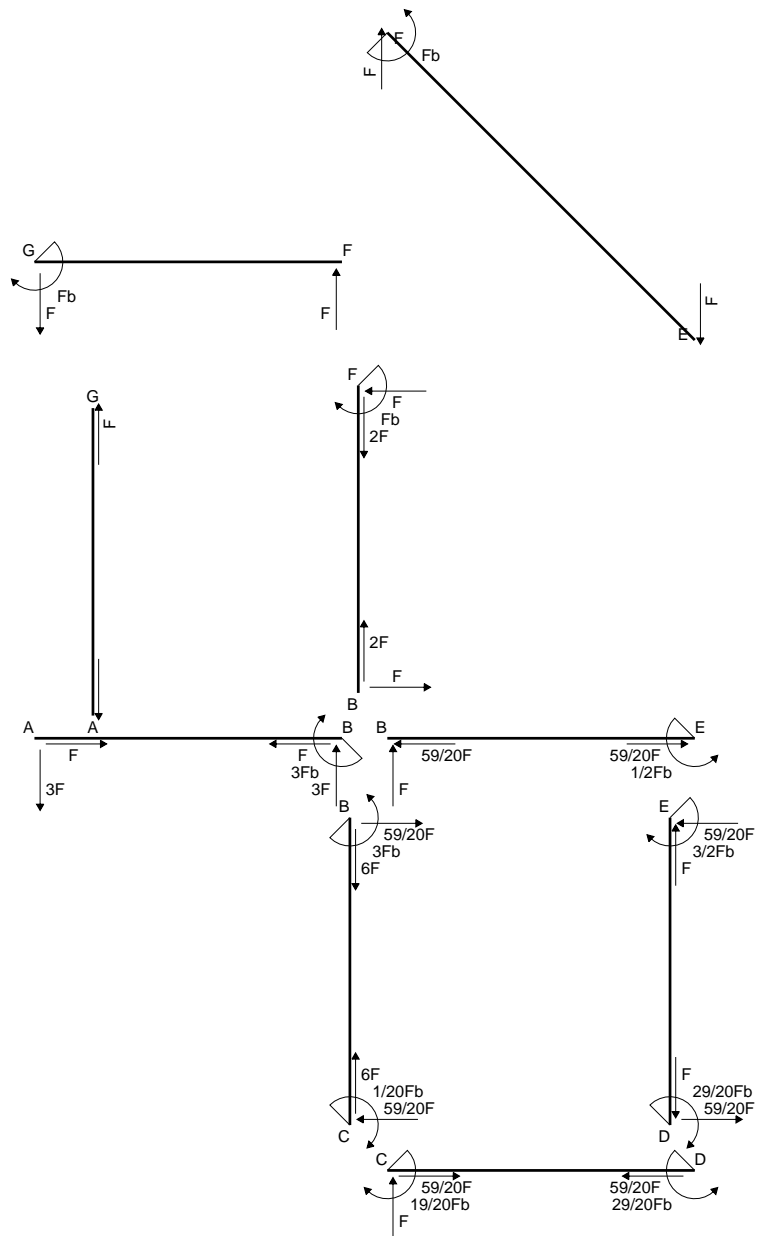

\oplus F_b

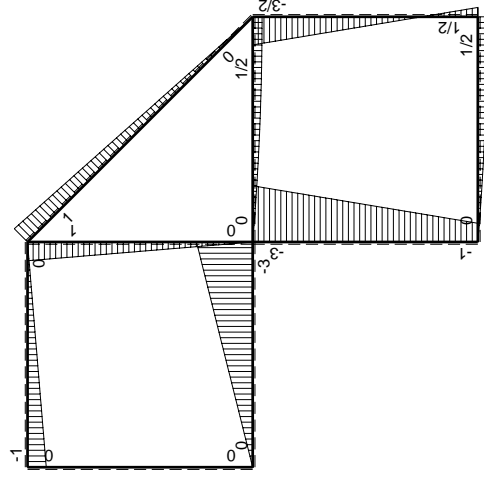
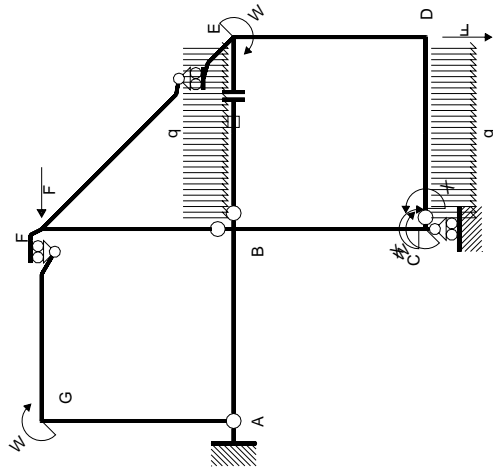

Schema di calcolo iperstatico

M_0 flessione da carichi assegnati

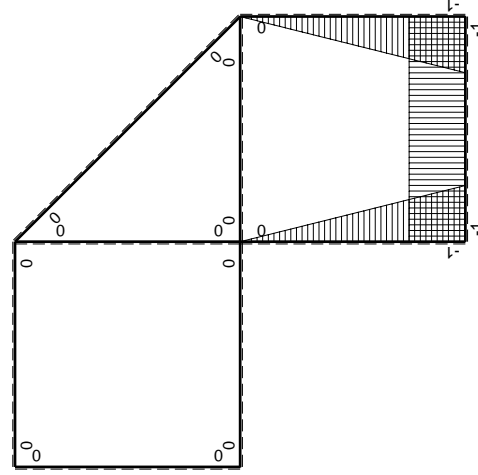

M_x flessione da iperstatica $X=1$

Quadro contribuiti PLV per iperstatica $X=W_{cd}$

\rightarrow	$M_x(x)$	$M_0(x)$	$M_x M_0$	$M_x M_x$	$\int M_x M_0 / EJ dx$	$\int M_x M_x / EJ dx$
AB b	0	-3Fx	0	0	0	0
BA b	0	3Fb-3Fx	0	0	0	0
BC b	-x/b	-3Fb+2Fx	$3Fx-2Fx^2/b$	x^2/b^2	$5/6Fb^2/EJ$	$1/3Xb/EJ$
CB b	1-x/b	Fb+2Fx	$Fb+Fx-2Fx^2/b$	$1-2x/b+x^2/b^2$	$-1/3Fb^2/EJ$	Xb/EJ
CD b	-1	$Fx-1/2qx^2$	$-Fx+1/2Fx^2/b$	1		
DC b	1	$-1/2Fb+1/2qx^2$	$-1/2Fb+1/2Fx^2/b$	1		
DE b	-1+x/b	$1/2Fb-2Fx$	$-1/2Fb+5/2Fx-2Fx^2/b$	$1-2x/b+x^2/b^2$	$1/12Fb^2/EJ$	$1/3Xb/EJ$
ED b	x/b	$3/2Fb-2Fx$	$3/2Fx-2Fx^2/b$	x^2/b^2		
EF $\sqrt{2}b$	0	$\sqrt{2}2Fx$	0	0	0	0
FG b	0	-Fx	0	0	0	0
GF b	0	Fb-Fx	0	0	0	0
GA b	0	0	0	0	0	0
AG b	0	0	0	0	0	0
FB b	0	Fb-Fx	0	0	0	0
BF b	0	-Fx	0	0	0	0
BE b	0	$Fx-1/2qx^2$	0	0	0	0
EB b	0	$-1/2Fb+1/2qx^2$	0	0	0	0
BE	elongazione asta $N_{1BE} \epsilon_{BE} = L_{BE}$				Fb^2/EJ	
	totali				$19/12Fb^2/EJ$	$5/3Xb/EJ$
	iperstatica $X=W_{cd}$				$-19/20Fb$	

Sviluppi di calcolo iperstatica

$$L_{BC}^{xx} = \int_0^b (x^2/b^2) 1/EJ dx = [1/3 x^3/b^2]_0^b 1/EJ$$

$$= (1/3 b) 1/EJ = 1/3 b/EJ$$

$$L_{CB}^{xx} = \int_0^b (1 - 2x/b + x^2/b^2) 1/EJ dx = [x - x^2/b + 1/3 x^3/b^2]_0^b 1/EJ$$

$$= (b - b + 1/3 b) 1/EJ = 1/3 b/EJ$$

$$L_{CD}^{xx} = \int_0^b (1) 1/EJ dx = [x]_0^b 1/EJ$$

$$= (b) 1/EJ = b/EJ$$

$$L_{DC}^{xx} = \int_0^b (1) 1/EJ dx = [x]_0^b 1/EJ$$

$$= (b) 1/EJ = b/EJ$$

$$L_{DE}^{xx} = \int_0^b (1 - 2x/b + x^2/b^2) 1/EJ dx = [x - x^2/b + 1/3 x^3/b^2]_0^b 1/EJ$$

$$= (b - b + 1/3 b) 1/EJ = 1/3 b/EJ$$

$$L_{ED}^{xx} = \int_0^b (x^2/b^2) 1/EJ dx = [1/3 x^3/b^2]_0^b 1/EJ$$

$$= (1/3 b) 1/EJ = 1/3 b/EJ$$

$$L_{BC}^{x_0} = \int_0^b (3x/b - 2x^2/b^2) Fb 1/EJ dx = [3/2 x^2/b - 2/3 x^3/b^2]_0^b Fb 1/EJ$$

$$= (3/2 b - 2/3 b) Fb 1/EJ = 5/6 Fb^2/EJ$$

$$L_{CB}^{x_0} = \int_0^b (1 + x/b - 2x^2/b^2) Fb 1/EJ dx = [x + 1/2 x^2/b - 2/3 x^3/b^2]_0^b Fb 1/EJ$$

$$= (b + 1/2 b - 2/3 b) Fb 1/EJ = 5/6 Fb^2/EJ$$

$$L_{CD}^{x_0} = \int_0^b (-x/b + 1/2 x^2/b^2) Fb 1/EJ dx = [-1/2 x^2/b + 1/6 x^3/b^2]_0^b Fb 1/EJ$$

$$= (-1/2 b + 1/6 b) Fb 1/EJ = -1/3 Fb^2/EJ$$

$$L_{DC}^{x_0} = \int_0^b (-1/2 + 1/2 x^2/b^2) Fb 1/EJ dx = [-1/2 x + 1/6 x^3/b^2]_0^b Fb 1/EJ$$

$$= (-1/2 b + 1/6 b) Fb 1/EJ = -1/3 Fb^2/EJ$$

$$L_{DE}^{x_0} = \int_0^b (-1/2 + 5/2 x/b - 2x^2/b^2) Fb 1/EJ dx = [-1/2 x + 5/4 x^2/b - 2/3 x^3/b^2]_0^b Fb 1/EJ$$

$$= (-1/2 b + 5/4 b - 2/3 b) Fb 1/EJ = 1/12 Fb^2/EJ$$

$$L_{ED}^{x_0} = \int_0^b (3/2 x/b - 2x^2/b^2) Fb 1/EJ dx = [3/4 x^2/b - 2/3 x^3/b^2]_0^b Fb 1/EJ$$

$$= (3/4 b - 2/3 b) Fb 1/EJ = 1/12 Fb^2/EJ$$

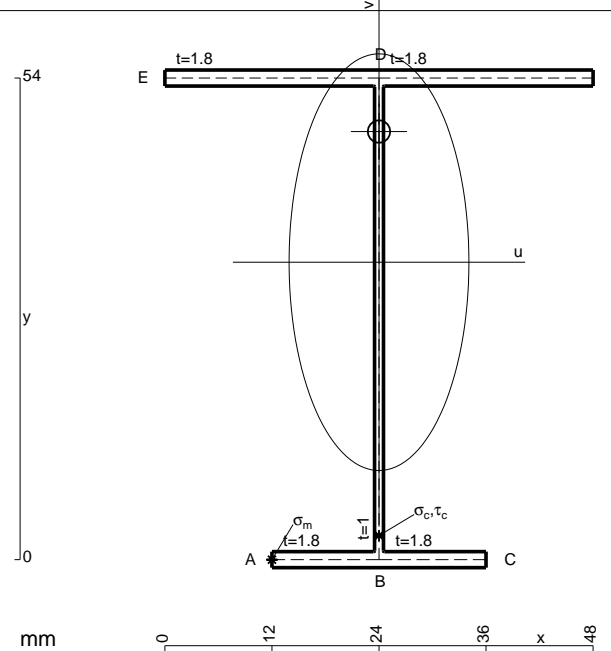

- A = 183.6 mm²
- J_u = 100190. mm⁴
- J_v = 18662. mm⁴
- J_t = 158. mm⁴
- y_o = 14.65 mm
- y_g = 33.35 mm
- N = -340. N
- T_y = -1020. N
- M_x = -673200. Nmm
- x_m = 12. mm
- u_m = -12. mm
- v_m = -33.35 mm
- σ_m = N/A - Mv/J_u = -226. N/mm²
- x_c = 24. mm
- v_c = -33.35 mm
- σ_c = N/A - Mv/J_u = -226. N/mm²
- τ_c = TS/tJ_u = 14.67 N/mm²
- τ_g = TS/tJ_u = 14.67 N/mm²
- t_c = 340. mm
- σ_o = √(σ² + 3τ²) = 227.4 N/mm²

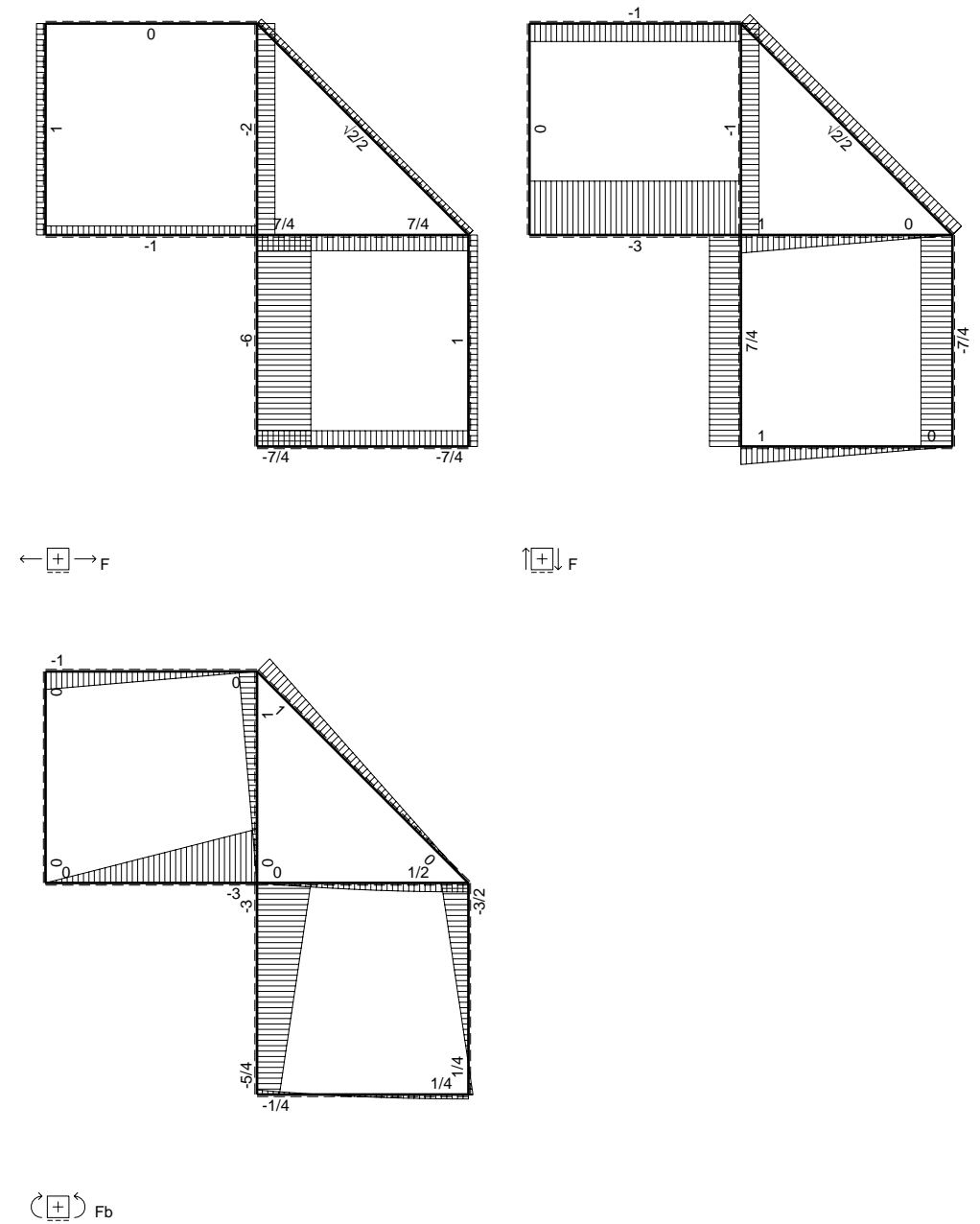
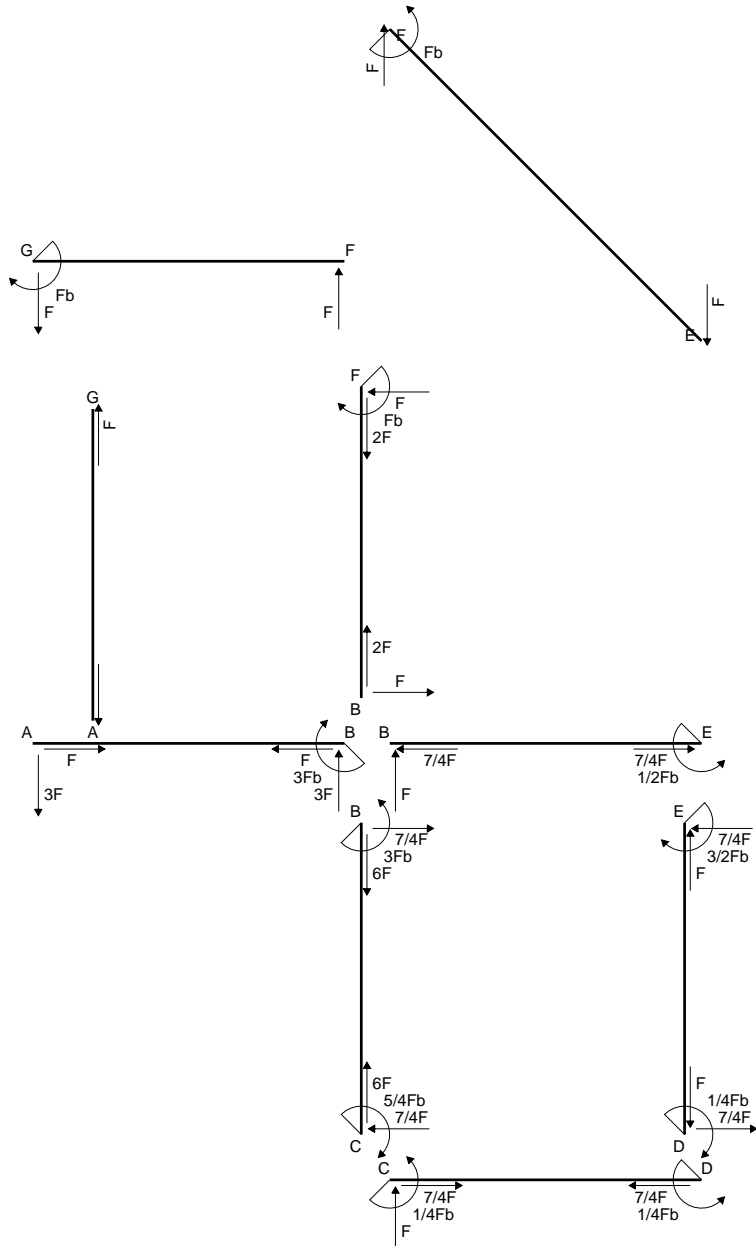

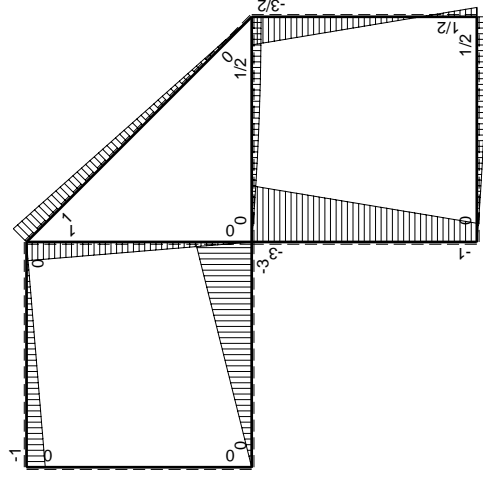
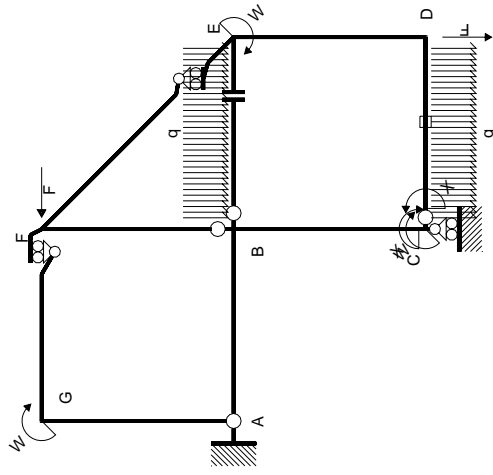

Schema di calcolo iperstatico

M_0 flessione da carichi assegnati

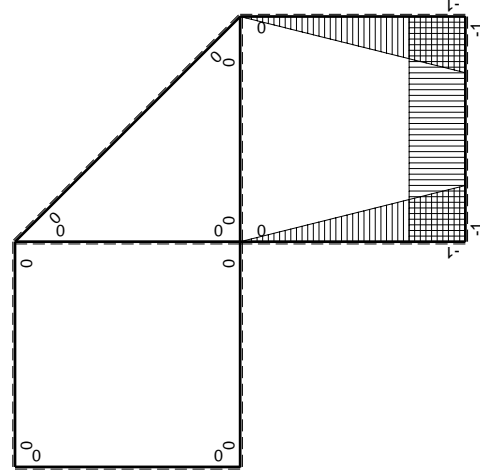

M_x flessione da iperstatica X=1

Quadro contributi PLV per iperstatica X=W_{cd}

→	$M_x(x)$	$M_0(x)$	$M_x M_0$	$M_x M_x$	$\int M_x M_0 / EJ dx$	$\int X M_x M_x / EJ dx$
AB b	0	-3Fx	0	0	0	0
BA b	0	3Fb-3Fx	0	0	0	0
BC b	-x/b	-3Fb+2Fx	3Fx-2Fx ² /b	x ² /b ²	5/6Fb ² /EJ	1/3Xb/EJ
CB b	1-x/b	Fb+2Fx	Fb+Fx-2Fx ² /b	1-2x/b+x ² /b ²	-1/3Fb ² /EJ	Xb/EJ
CD b	-1	Fx-1/2qx ²	-Fx+1/2Fx ² /b	1		
DC b	1	-1/2Fb+1/2qx ²	-1/2Fb+1/2Fx ² /b	1		
DE b	-1+x/b	1/2Fb-2Fx	-1/2Fb+5/2Fx-2Fx ² /b	1-2x/b+x ² /b ²	1/12Fb ² /EJ	1/3Xb/EJ
ED b	x/b	3/2Fb-2Fx	3/2Fx-2Fx ² /b	x ² /b ²		
EF √2b	0	√2/2Fx	0	0	0	0
FG b	0	-Fx	0	0	0	0
GF b	0	Fb-Fx	0	0	0	0
GA b	0	0	0	0	0	0
AG b	0	0	0	0	0	0
FB b	0	Fb-Fx	0	0	0	0
BF b	0	-Fx	0	0	0	0
BE b	0	Fx-1/2qx ²	0	0	0	0
EB b	0	-1/2Fb+1/2qx ²	0	0	0	0
CD	elongazione asta $N_{1,cd} \epsilon_{cd} L_{cd}$				-Fb ² /EJ	
	totali				-5/12Fb ² /EJ	5/3Xb/EJ
	iperstatica X=W _{cd}				1/4Fb	

Sviluppi di calcolo iperstatica

$$L_{BC}^{xx} = \int_0^b (x^2/b^2) 1/EJ dx = [1/3 x^3/b^2]_0^b 1/EJ$$

$$= (1/3 b) 1/EJ = 1/3 b/EJ$$

$$L_{CB}^{xx} = \int_0^b (1 - 2x/b + x^2/b^2) 1/EJ dx = [x - x^2/b + 1/3 x^3/b^2]_0^b 1/EJ$$

$$= (b - b + 1/3 b) 1/EJ = 1/3 b/EJ$$

$$L_{CD}^{xx} = \int_0^b (1) 1/EJ dx = [x]_0^b 1/EJ$$

$$= (b) 1/EJ = b/EJ$$

$$L_{DC}^{xx} = \int_0^b (1) 1/EJ dx = [x]_0^b 1/EJ$$

$$= (b) 1/EJ = b/EJ$$

$$L_{DE}^{xx} = \int_0^b (1 - 2x/b + x^2/b^2) 1/EJ dx = [x - x^2/b + 1/3 x^3/b^2]_0^b 1/EJ$$

$$= (b - b + 1/3 b) 1/EJ = 1/3 b/EJ$$

$$L_{ED}^{xx} = \int_0^b (x^2/b^2) 1/EJ dx = [1/3 x^3/b^2]_0^b 1/EJ$$

$$= (1/3 b) 1/EJ = 1/3 b/EJ$$

$$L_{BC}^{xo} = \int_0^b (3x/b - 2x^2/b^2) Fb 1/EJ dx = [3/2 x^2/b - 2/3 x^3/b^2]_0^b Fb 1/EJ$$

$$= (3/2 b - 2/3 b) Fb 1/EJ = 5/6 Fb^2/EJ$$

$$L_{CB}^{xo} = \int_0^b (1 + x/b - 2x^2/b^2) Fb 1/EJ dx = [x + 1/2 x^2/b - 2/3 x^3/b^2]_0^b Fb 1/EJ$$

$$= (b + 1/2 b - 2/3 b) Fb 1/EJ = 5/6 Fb^2/EJ$$

$$L_{CD}^{xo} = \int_0^b (-x/b + 1/2 x^2/b^2) Fb 1/EJ dx + 1 (-1) 1 Fb^2/EJ$$

$$= [-1/2 x^2/b + 1/6 x^3/b^2]_0^b Fb 1/EJ + 1 (-1) 1 Fb^2/EJ$$

$$= (-1/2 b + 1/6 b) Fb 1/EJ + 1 (-1) 1 Fb^2/EJ = -4/3 Fb^2/EJ$$

$$L_{DC}^{xo} = \int_0^b (-1/2 + 1/2 x^2/b^2) Fb 1/EJ dx + 1 (-1) 1 Fb^2/EJ$$

$$= [-1/2 x + 1/6 x^3/b^2]_0^b Fb 1/EJ + 1 (-1) 1 Fb^2/EJ$$

$$= (-1/2 b + 1/6 b) Fb 1/EJ + 1 (-1) 1 Fb^2/EJ = -4/3 Fb^2/EJ$$

$$L_{DE}^{xo} = \int_0^b (-1/2 + 5/2 x/b - 2x^2/b^2) Fb 1/EJ dx = [-1/2 x + 5/4 x^2/b - 2/3 x^3/b^2]_0^b Fb 1/EJ$$

$$= (-1/2 b + 5/4 b - 2/3 b) Fb 1/EJ = 1/12 Fb^2/EJ$$

$$L_{ED}^{xo} = \int_0^b (3/2 x/b - 2x^2/b^2) Fb 1/EJ dx = [3/4 x^2/b - 2/3 x^3/b^2]_0^b Fb 1/EJ$$

$$= (3/4 b - 2/3 b) Fb 1/EJ = 1/12 Fb^2/EJ$$

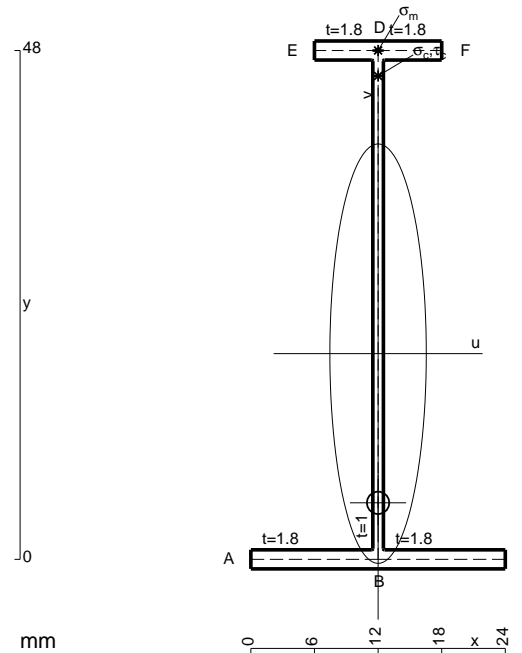

- A = 112.8 mm²
- J_u = 44158. mm⁴
- J_v = 2333. mm⁴
- J_t = 85.98 mm⁴
- y_o = -14.07 mm
- y_g = 19.4 mm
- N = -190. N
- T_y = -570. N
- M_x = -359100. Nmm
- x_m = 12. mm
- y_m = 48. mm
- v_m = 28.6 mm
- σ_m = N/A-Mv/J_u = 230.9 N/mm²
- y_c = 2. mm
- u_c = -12. mm
- v_c = -17.4 mm
- σ_c = N/A-Mv/J_u = 230.9 N/mm²
- τ_c = TS_y/tJ_u = 7.973 N/mm²
- τ_g = TS_y/tJ_u = 7.973 N/mm²
- t_c = 190. mm
- σ_o = √σ²+3τ² = 231.3 N/mm²

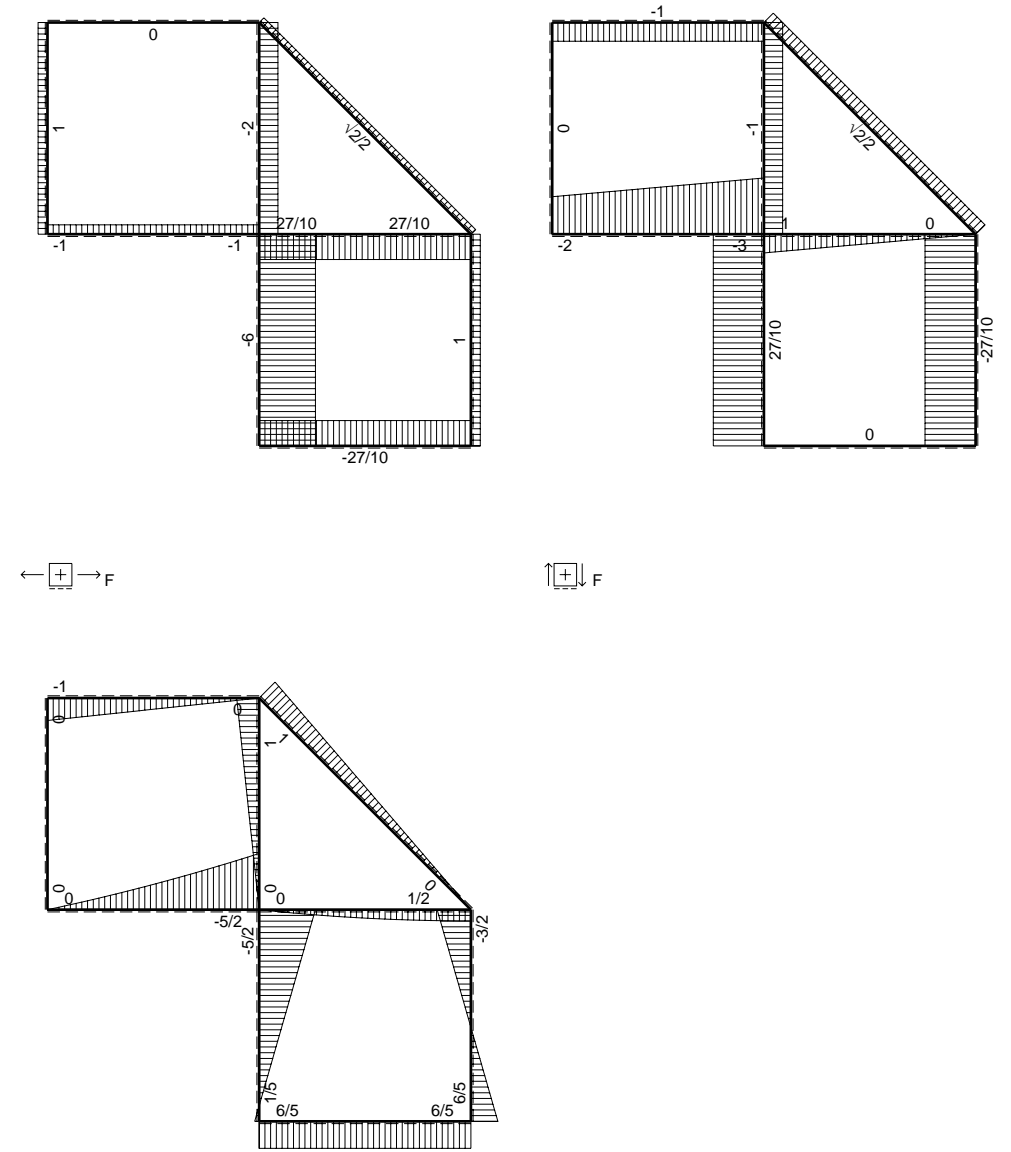
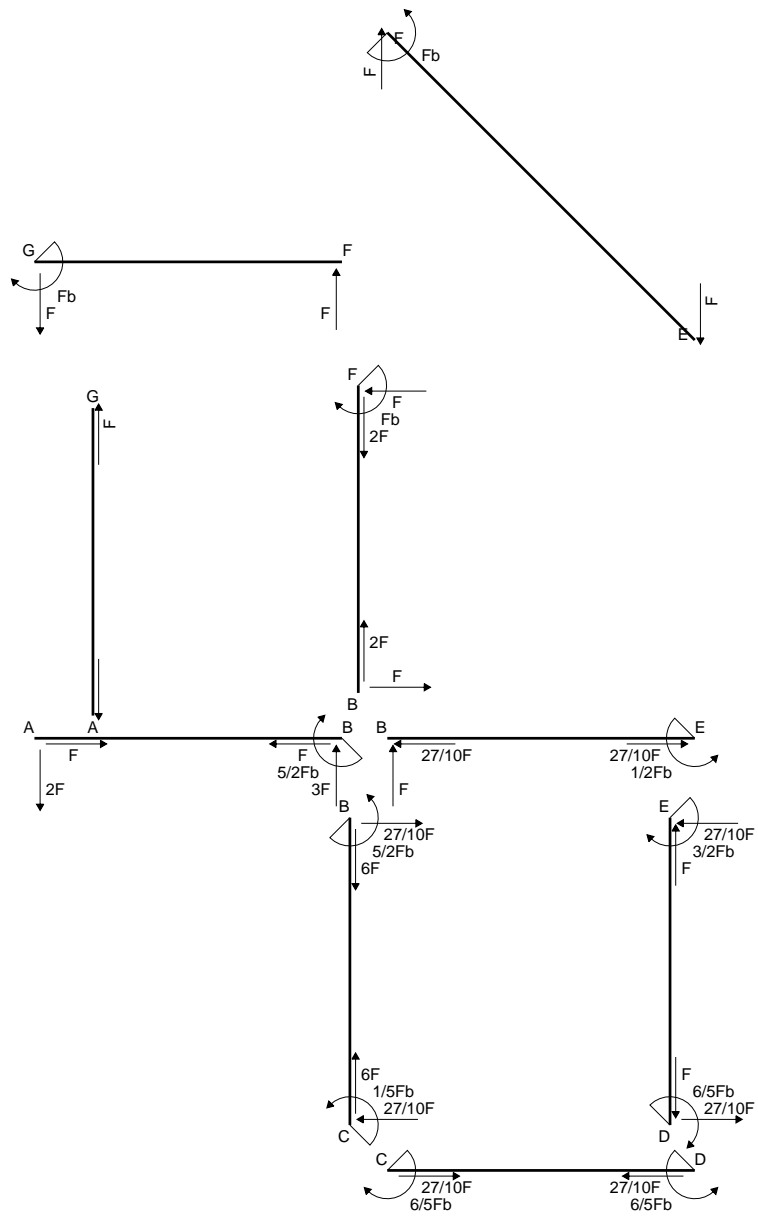

\oplus F_b

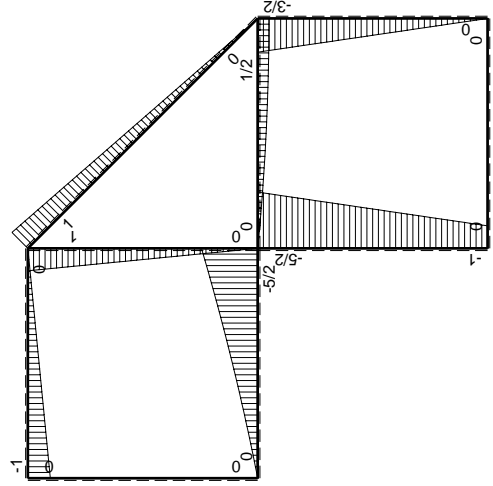
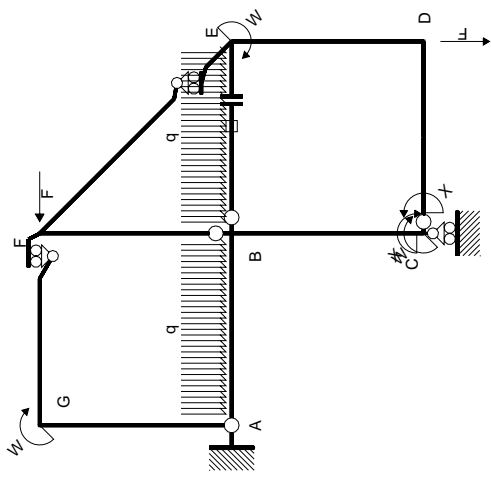

Schema di calcolo iperstatico

(\oplus) M_0 flessione da carichi assegnati

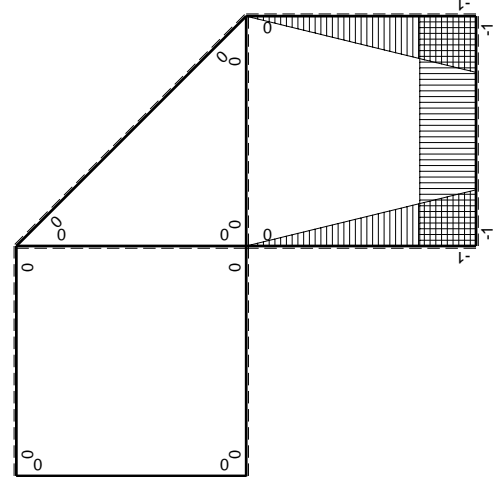

(\oplus) M_x flessione da iperstatica X=1

Quadro contribuiti PLV per iperstatica X=W_{cd}

→	$M_x(x)$	$M_0(x)$	$M_x M_0$	$M_x M_x$	$\int M_x M_0 / EJ dx$	$\int M_x M_x / EJ dx$
AB b	0	$-2Fx - 1/2qx^2$	0	0	0	0
BA b	0	$5/2Fb - 3Fx + 1/2qx^2$	0	0	0	0
BC b	$-x/b$	$-5/2Fb + 3/2Fx$	$5/2Fx - 3/2Fx^2/b$	x^2/b^2	$3/4Fb^2/EJ$	$1/3Xb/EJ$
CB b	$1-x/b$	$Fb + 3/2Fx$	$Fb + 1/2Fx - 3/2Fx^2/b$	$1 - 2x/b + x^2/b^2$	0	Xb/EJ
CD b	-1	0	0	1	0	0
DC b	1	0	0	1	0	0
DE b	$-1+x/b$	$-3/2Fx$	$3/2Fx - 3/2Fx^2/b$	$1 - 2x/b + x^2/b^2$	$1/4Fb^2/EJ$	$1/3Xb/EJ$
ED b	x/b	$3/2Fb - 3/2Fx$	$3/2Fx - 3/2Fx^2/b$	x^2/b^2	0	0
EF $\sqrt{2}b$	0	$\sqrt{2}/2Fx$	0	0	0	0
FG b	0	-Fx	0	0	0	0
GF b	0	$Fb - Fx$	0	0	0	0
GA b	0	0	0	0	0	0
AG b	0	0	0	0	0	0
FB b	0	$Fb - Fx$	0	0	0	0
BF b	0	-Fx	0	0	0	0
BE b	0	$Fx - 1/2qx^2$	0	0	0	0
EB b	0	$-1/2Fb + 1/2qx^2$	0	0	0	0
BE	elongazione asta $N_{1, BE}^E - L_{BE}^{E-BE}$				Fb^2/EJ	
	totali				$2Fb^2/EJ$	$5/3Xb/EJ$
	iperstatica X=W _{cd}				$-6/5Fb$	

Sviluppi di calcolo iperstatica

$$L_{BC}^{xx} = \int_0^b (x^2/b^2) 1/EJ dx = [1/3 x^3/b^2]_0^b 1/EJ$$

$$= (1/3 b) 1/EJ = 1/3 b/EJ$$

$$L_{CB}^{xx} = \int_0^b (1 - 2x/b + x^2/b^2) 1/EJ dx = [x - x^2/b + 1/3 x^3/b^2]_0^b 1/EJ$$

$$= (b - b + 1/3 b) 1/EJ = 1/3 b/EJ$$

$$L_{CD}^{xx} = \int_0^b (1) 1/EJ dx = [x]_0^b 1/EJ$$

$$= (b) 1/EJ = b/EJ$$

$$L_{DC}^{xx} = \int_0^b (1) 1/EJ dx = [x]_0^b 1/EJ$$

$$= (b) 1/EJ = b/EJ$$

$$L_{DE}^{xx} = \int_0^b (1 - 2x/b + x^2/b^2) 1/EJ dx = [x - x^2/b + 1/3 x^3/b^2]_0^b 1/EJ$$

$$= (b - b + 1/3 b) 1/EJ = 1/3 b/EJ$$

$$L_{ED}^{xx} = \int_0^b (x^2/b^2) 1/EJ dx = [1/3 x^3/b^2]_0^b 1/EJ$$

$$= (1/3 b) 1/EJ = 1/3 b/EJ$$

$$L_{BC}^{x_0} = \int_0^b (5/2 x/b - 3/2 x^2/b^2) Fb 1/EJ dx = [5/4 x^2/b - 1/2 x^3/b^2]_0^b Fb 1/EJ$$

$$= (5/4 b - 1/2 b) Fb 1/EJ = 3/4 Fb^2/EJ$$

$$L_{CB}^{x_0} = \int_0^b (1 + 1/2 x/b - 3/2 x^2/b^2) Fb 1/EJ dx = [x + 1/4 x^2/b - 1/2 x^3/b^2]_0^b Fb 1/EJ$$

$$= (b + 1/4 b - 1/2 b) Fb 1/EJ = 3/4 Fb^2/EJ$$

$$L_{DE}^{x_0} = \int_0^b (3/2 x/b - 3/2 x^2/b^2) Fb 1/EJ dx = [3/4 x^2/b - 1/2 x^3/b^2]_0^b Fb 1/EJ$$

$$= (3/4 b - 1/2 b) Fb 1/EJ = 1/4 Fb^2/EJ$$

$$L_{ED}^{x_0} = \int_0^b (3/2 x/b - 3/2 x^2/b^2) Fb 1/EJ dx = [3/4 x^2/b - 1/2 x^3/b^2]_0^b Fb 1/EJ$$

$$= (3/4 b - 1/2 b) Fb 1/EJ = 1/4 Fb^2/EJ$$

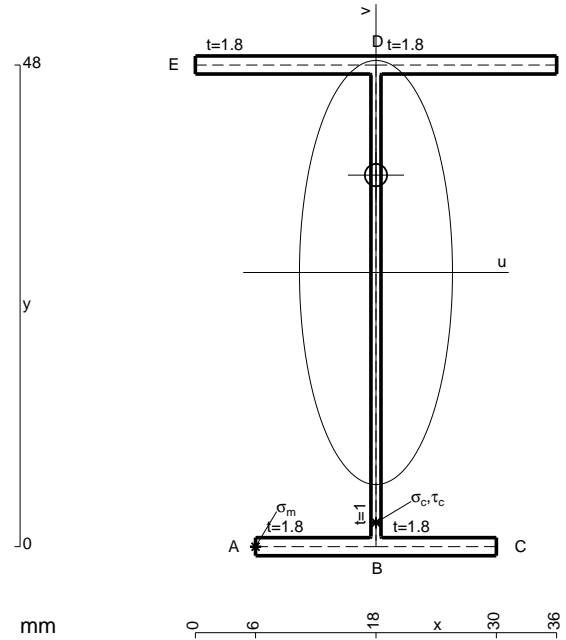

- A = 156. mm²
- J_u = 69701. mm⁴
- J_v = 9072. mm⁴
- J_I = 132.6 mm⁴
- y_o = 9.705 mm
- y_g = 27.32 mm
- N = -300. N
- T_y = -900. N
- M_x = -502500. Nmm
- x_m = 6. mm
- u_m = -12. mm
- v_m = -27.32 mm
- σ_m = N/A - Mv/J_u = -198.9 N/mm²
- x_c = 18. mm
- v_c = -27.32 mm
- σ_c = N/A - Mv/J_u = -198.9 N/mm²
- τ_c = TS'/tJ_u = 15.24 N/mm²
- τ_g = TS'/tJ_u = 15.24 N/mm²
- t_c = 300. mm
- σ_o = √σ² + 3τ² = 200.6 N/mm²

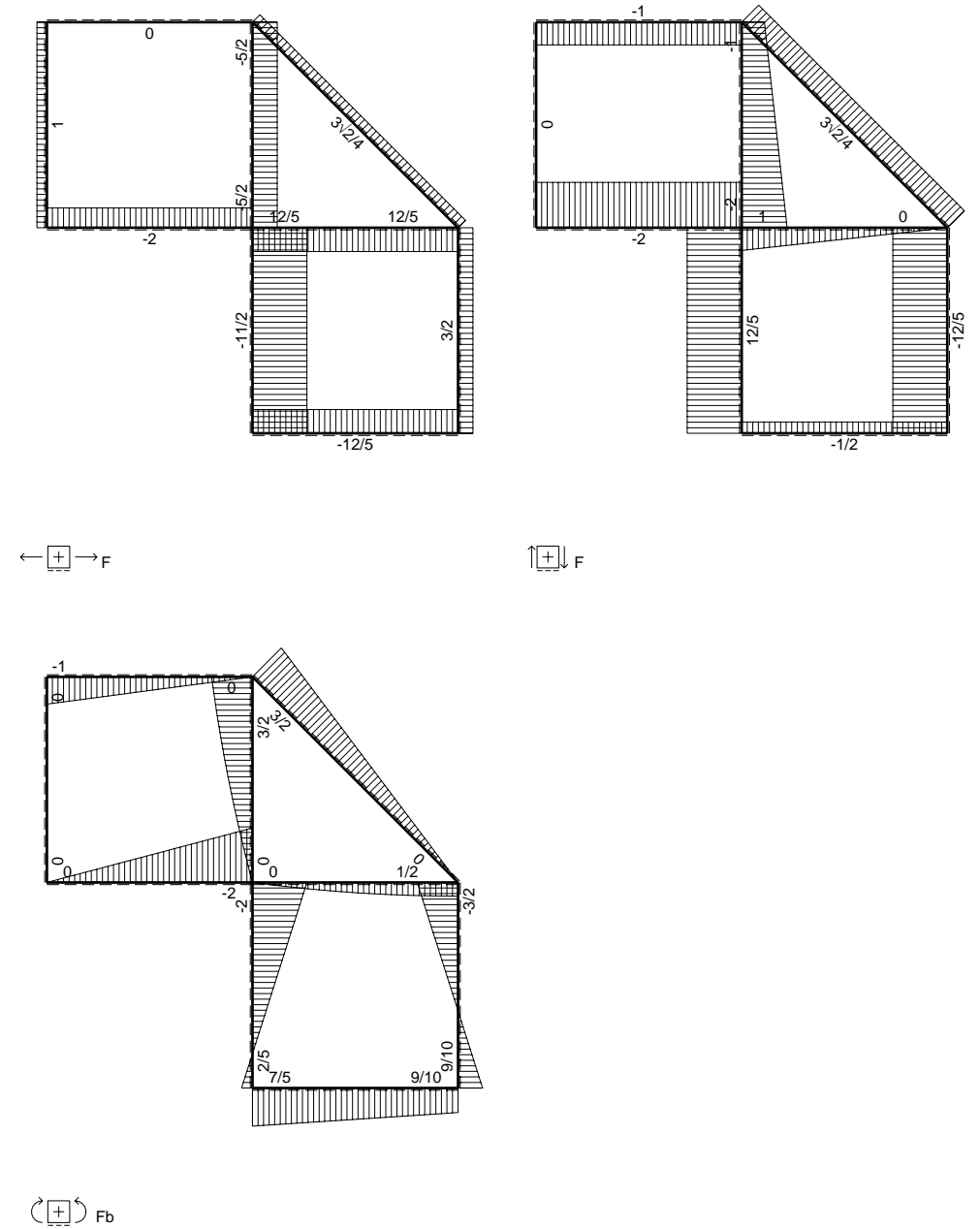
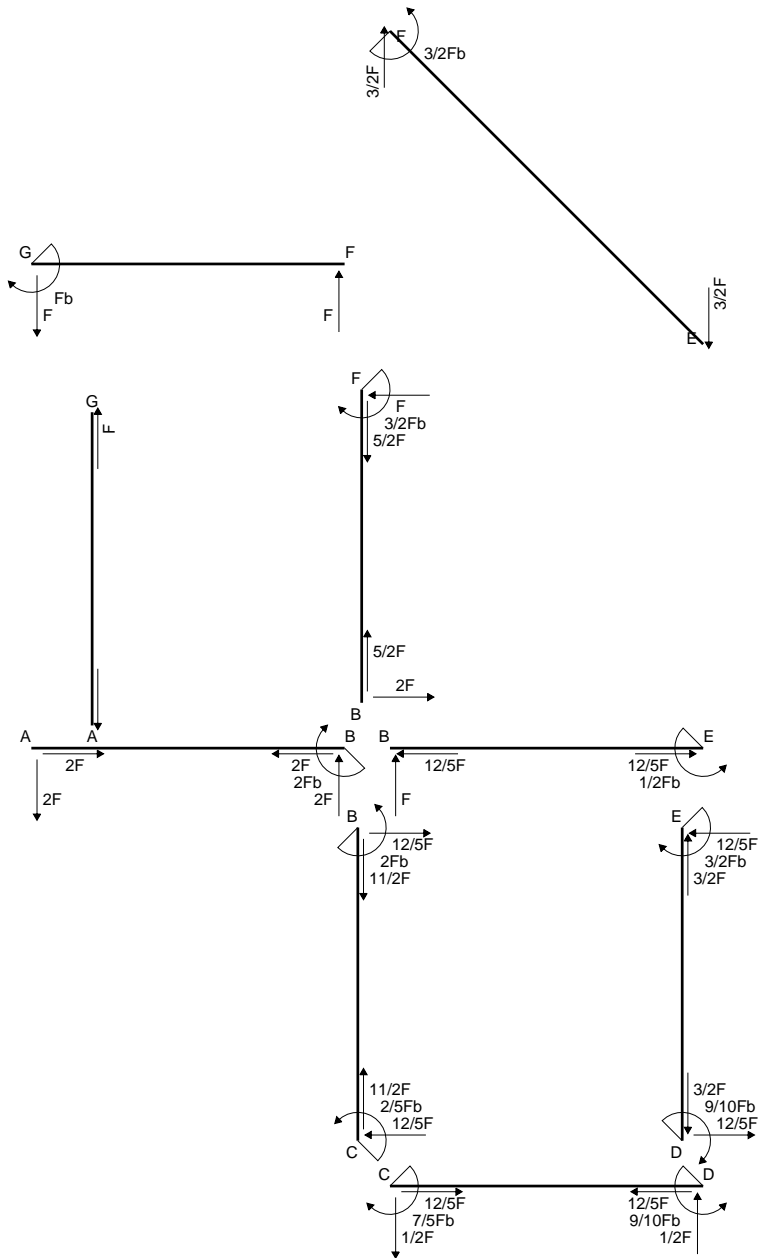

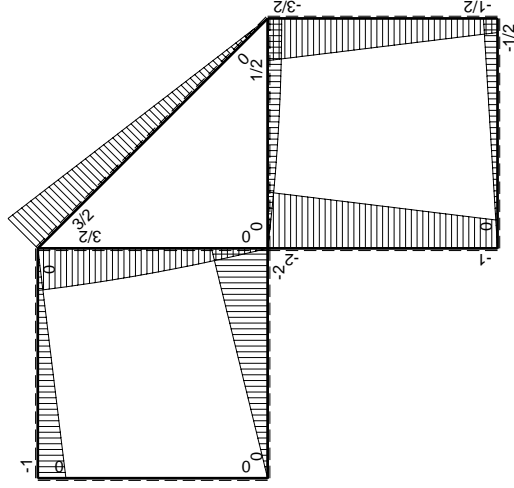
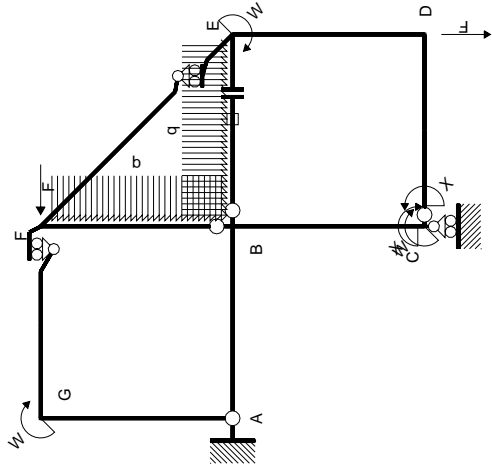

Schema di calcolo iperstatico

M_0 flessione da carichi assegnati

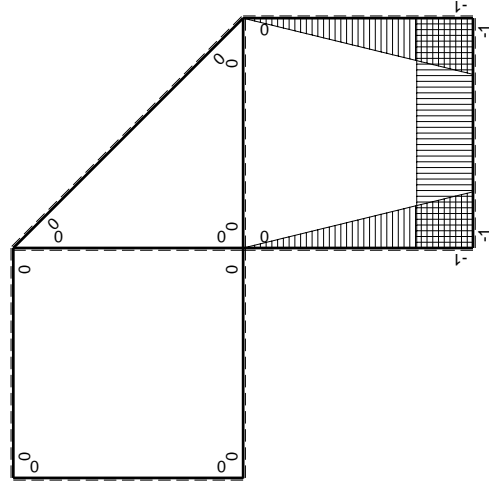

M_x flessione da iperstatica X=1

Quadro contribuiti PLV per iperstatica X=W_{cd}

→	$M_x(x)$	$M_0(x)$	$M_x M_0$	$M_x M_x$	$\int M_x M_0 / EJ dx$	$\int X M_x M_x / EJ dx$
AB b	0	-2Fx	0	0	0	0
BA b	0	2Fb-2Fx	0	0	0	0
BC b	-x/b	-2Fb+Fx	2Fx-Fx ² /b	x ² /b ²	2/3Fb ² /EJ	1/3Xb/EJ
CB b	1-x/b	Fb+Fx	Fb-Fx ² /b	1-2x/b+x ² /b ²	1/4Fb ² /EJ	Xb/EJ
CD b	-1	-1/2Fx	1/2Fx	1	1/4Fb ² /EJ	Xb/EJ
DC b	1	1/2Fb-1/2Fx	1/2Fb-1/2Fx	1	1/4Fb ² /EJ	Xb/EJ
DE b	-1+x/b	-1/2Fb-Fx	1/2Fb+1/2Fx-Fx ² /b	1-2x/b+x ² /b ²	5/12Fb ² /EJ	1/3Xb/EJ
ED b	x/b	3/2Fb-Fx	3/2Fx-Fx ² /b	x ² /b ²	5/12Fb ² /EJ	1/3Xb/EJ
EF √2b	0	3√2/4Fx	0	0	0	0
FG b	0	-Fx	0	0	0	0
GF b	0	Fb-Fx	0	0	0	0
GA b	0	0	0	0	0	0
AG b	0	0	0	0	0	0
FB b	0	3/2Fb-Fx-1/2qx ²	0	0	0	0
BF b	0	-2Fx+1/2qx ²	0	0	0	0
BE b	0	Fx-1/2qx ²	0	0	0	0
EB b	0	-1/2Fb+1/2qx ²	0	0	0	0
BE	elongazione asta $N_{1, BE}^E - N_{BE}^E - N_{BE}^E$				Fb ² /EJ	
	totali				7/3Fb ² /EJ	5/3Xb/EJ
	iperstatica X=W _{cd}				-7/5Fb	

Sviluppi di calcolo iperstatica

$$L_{BC}^{xx} = \int_0^b (x^2/b^2) 1/EJ dx = [1/3 x^3/b^2]_0^b 1/EJ$$

$$= (1/3 b) 1/EJ = 1/3 b/EJ$$

$$L_{CB}^{xx} = \int_0^b (1 - 2x/b + x^2/b^2) 1/EJ dx = [x - x^2/b + 1/3 x^3/b^2]_0^b 1/EJ$$

$$= (b - b + 1/3 b) 1/EJ = 1/3 b/EJ$$

$$L_{CD}^{xx} = \int_0^b (1) 1/EJ dx = [x]_0^b 1/EJ$$

$$= (b) 1/EJ = b/EJ$$

$$L_{DC}^{xx} = \int_0^b (1) 1/EJ dx = [x]_0^b 1/EJ$$

$$= (b) 1/EJ = b/EJ$$

$$L_{DE}^{xx} = \int_0^b (1 - 2x/b + x^2/b^2) 1/EJ dx = [x - x^2/b + 1/3 x^3/b^2]_0^b 1/EJ$$

$$= (b - b + 1/3 b) 1/EJ = 1/3 b/EJ$$

$$L_{ED}^{xx} = \int_0^b (x^2/b^2) 1/EJ dx = [1/3 x^3/b^2]_0^b 1/EJ$$

$$= (1/3 b) 1/EJ = 1/3 b/EJ$$

$$L_{BC}^{xo} = \int_0^b (2x/b - x^2/b^2) Fb 1/EJ dx = [x^2/b - 1/3 x^3/b^2]_0^b Fb 1/EJ$$

$$= (b - 1/3 b) Fb 1/EJ = 2/3 Fb^2/EJ$$

$$L_{CB}^{xo} = \int_0^b (1 - x^2/b^2) Fb 1/EJ dx = [x - 1/3 x^3/b^2]_0^b Fb 1/EJ$$

$$= (b - 1/3 b) Fb 1/EJ = 2/3 Fb^2/EJ$$

$$L_{CD}^{xo} = \int_0^b (1/2 x/b) Fb 1/EJ dx = [1/4 x^2/b]_0^b Fb 1/EJ$$

$$= (1/4 b) Fb 1/EJ = 1/4 Fb^2/EJ$$

$$L_{DC}^{xo} = \int_0^b (1/2 - 1/2 x/b) Fb 1/EJ dx = [1/2 x - 1/4 x^2/b]_0^b Fb 1/EJ$$

$$= (1/2 b - 1/4 b) Fb 1/EJ = 1/4 Fb^2/EJ$$

$$L_{DE}^{xo} = \int_0^b (1/2 + 1/2 x/b - x^2/b^2) Fb 1/EJ dx = [1/2 x + 1/4 x^2/b - 1/3 x^3/b^2]_0^b Fb 1/EJ$$

$$= (1/2 b + 1/4 b - 1/3 b) Fb 1/EJ = 5/12 Fb^2/EJ$$

$$L_{ED}^{xo} = \int_0^b (3/2 x/b - x^2/b^2) Fb 1/EJ dx = [3/4 x^2/b - 1/3 x^3/b^2]_0^b Fb 1/EJ$$

$$= (3/4 b - 1/3 b) Fb 1/EJ = 5/12 Fb^2/EJ$$

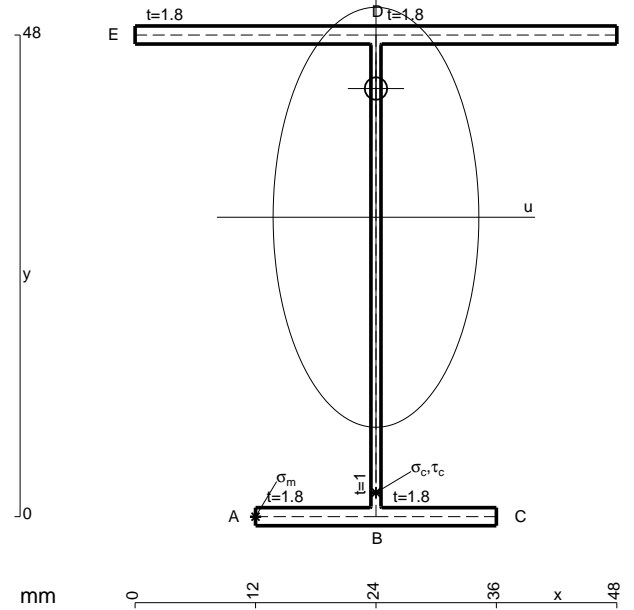

- A = 177.6 mm²
- J_u = 77813. mm⁴
- J_v = 18662. mm⁴
- J_i = 156. mm⁴
- y_o = 12.83 mm
- y_g = 29.84 mm
- N = -740. N
- T_y = -740. N
- M_x = -532800. Nmm
- x_m = 12. mm
- u_m = -12. mm
- v_m = -29.84 mm
- σ_m = N/A-Mv/J_u = -208.5 N/mm²
- x_c = 24. mm
- v_c = -29.84 mm
- σ_c = N/A-Mv/J_u = -208.5 N/mm²
- τ_c = TS'/tJ_u = 12.26 N/mm²
- τ_g = TS'/tJ_u = 12.26 N/mm²
- t_c = 370. mm
- σ_o = √σ²+3τ² = 209.6 N/mm²

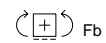
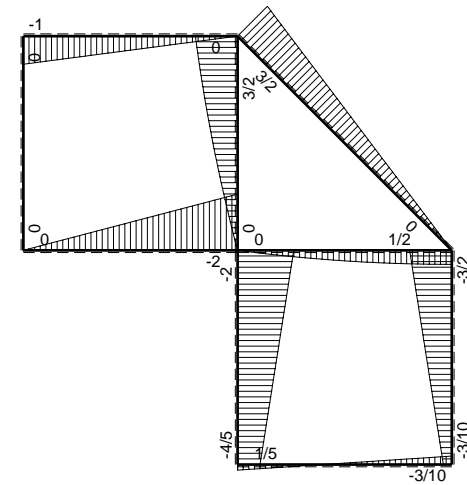
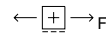
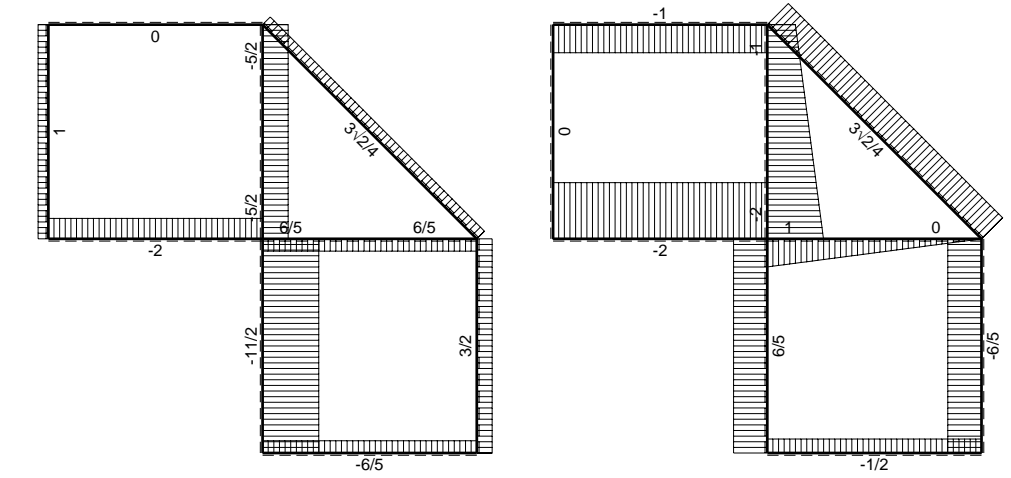
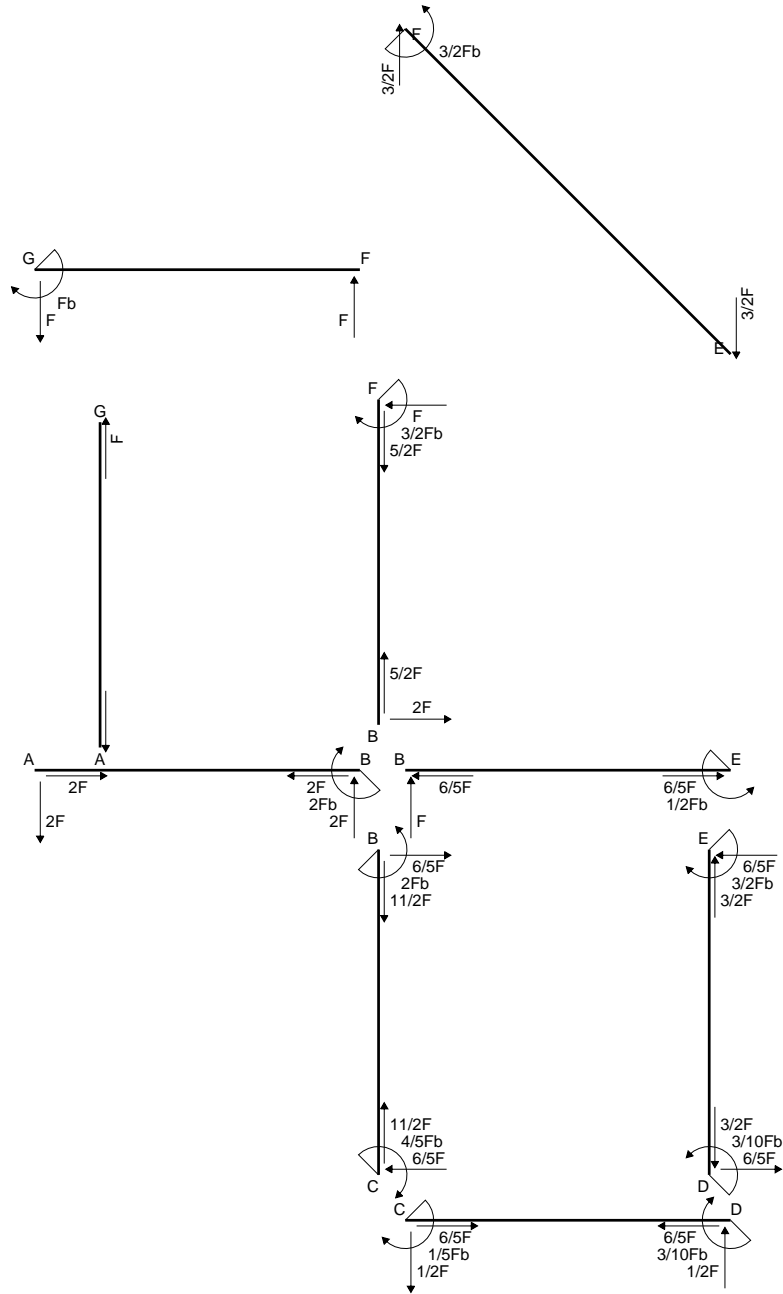

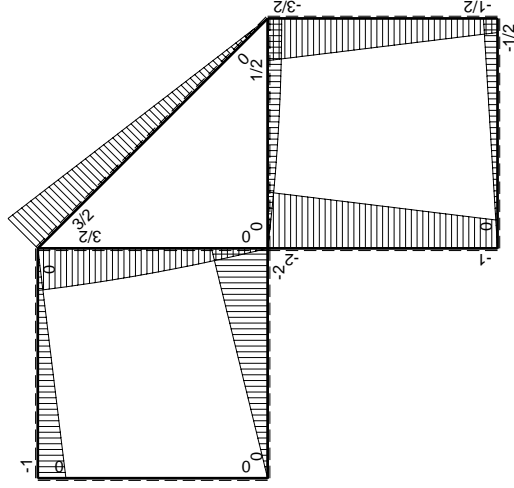
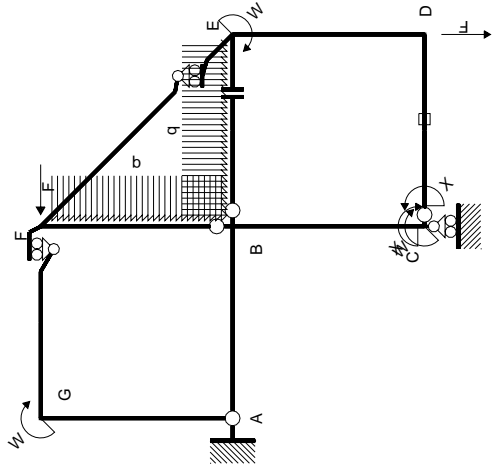

Schema di calcolo iperstatico

M_0 flessione da carichi assegnati

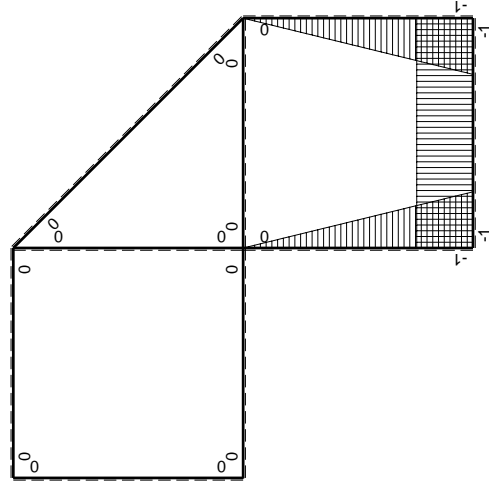

M_x flessione da iperstatica $X=1$

Quadro contribuiti PLV per iperstatica $X=W_{cd}$

\rightarrow	$M_x(x)$	$M_0(x)$	$M_x M_0$	$M_x M_x$	$\int M_x M_0 / EJ dx$	$\int X M_x M_x / EJ dx$
AB b	0	-2Fx	0	0	0	0
BA b	0	2Fb-2Fx	0	0	0	0
BC b	-x/b	-2Fb+Fx	2Fx-Fx ² /b	x ² /b ²	2/3Fb ² /EJ	1/3Xb/EJ
CB b	1-x/b	Fb+Fx	Fb-Fx ² /b	1-2x/b+x ² /b ²	1/4Fb ² /EJ	Xb/EJ
CD b	-1	-1/2Fx	1/2Fx	1	1/4Fb ² /EJ	Xb/EJ
DC b	1	1/2Fb-1/2Fx	1/2Fb-1/2Fx	1	1/4Fb ² /EJ	Xb/EJ
DE b	-1+x/b	-1/2Fb-Fx	1/2Fb+1/2Fx-Fx ² /b	1-2x/b+x ² /b ²	5/12Fb ² /EJ	1/3Xb/EJ
ED b	x/b	3/2Fb-Fx	3/2Fx-Fx ² /b	x ² /b ²	5/12Fb ² /EJ	1/3Xb/EJ
EF $\sqrt{2}b$	0	3 $\sqrt{2}$ /4Fx	0	0	0	0
FG b	0	-Fx	0	0	0	0
GF b	0	Fb-Fx	0	0	0	0
GA b	0	0	0	0	0	0
AG b	0	0	0	0	0	0
FB b	0	3/2Fb-Fx-1/2qx ²	0	0	0	0
BF b	0	-2Fx+1/2qx ²	0	0	0	0
BE b	0	Fx-1/2qx ²	0	0	0	0
EB b	0	-1/2Fb+1/2qx ²	0	0	0	0
CD	elongazione asta $N_{1,cd} \epsilon_{cd} L_{cd}$				-Fb ² /EJ	
	totali				1/3Fb ² /EJ	5/3Xb/EJ
	iperstatica $X=W_{cd}$				-1/5Fb	

Sviluppi di calcolo iperstatica

$$L_{BC}^{xx} = \int_0^b (x^2/b^2) 1/EJ dx = [1/3 x^3/b^2]_0^b 1/EJ$$

$$= (1/3 b) 1/EJ = 1/3 b/EJ$$

$$L_{CB}^{xx} = \int_0^b (1 - 2x/b + x^2/b^2) 1/EJ dx = [x - x^2/b + 1/3 x^3/b^2]_0^b 1/EJ$$

$$= (b - b + 1/3 b) 1/EJ = 1/3 b/EJ$$

$$L_{CD}^{xx} = \int_0^b (1) 1/EJ dx = [x]_0^b 1/EJ$$

$$= (b) 1/EJ = b/EJ$$

$$L_{DC}^{xx} = \int_0^b (1) 1/EJ dx = [x]_0^b 1/EJ$$

$$= (b) 1/EJ = b/EJ$$

$$L_{DE}^{xx} = \int_0^b (1 - 2x/b + x^2/b^2) 1/EJ dx = [x - x^2/b + 1/3 x^3/b^2]_0^b 1/EJ$$

$$= (b - b + 1/3 b) 1/EJ = 1/3 b/EJ$$

$$L_{ED}^{xx} = \int_0^b (x^2/b^2) 1/EJ dx = [1/3 x^3/b^2]_0^b 1/EJ$$

$$= (1/3 b) 1/EJ = 1/3 b/EJ$$

$$L_{BC}^{xo} = \int_0^b (2x/b - x^2/b^2) Fb 1/EJ dx = [x^2/b - 1/3 x^3/b^2]_0^b Fb 1/EJ$$

$$= (b - 1/3 b) Fb 1/EJ = 2/3 Fb^2/EJ$$

$$L_{CB}^{xo} = \int_0^b (1 - x^2/b^2) Fb 1/EJ dx = [x - 1/3 x^3/b^2]_0^b Fb 1/EJ$$

$$= (b - 1/3 b) Fb 1/EJ = 2/3 Fb^2/EJ$$

$$L_{CD}^{xo} = \int_0^b (1/2 x/b) Fb 1/EJ dx + 1 (-1) 1 Fb^2/EJ = [1/4 x^2/b]_0^b Fb 1/EJ + 1 (-1) 1 Fb^2/EJ$$

$$= (1/4 b) Fb 1/EJ + 1 (-1) 1 Fb^2/EJ = -3/4 Fb^2/EJ$$

$$L_{DC}^{xo} = \int_0^b (1/2 - 1/2 x/b) Fb 1/EJ dx + 1 (-1) 1 Fb^2/EJ = [1/2 x - 1/4 x^2/b]_0^b Fb 1/EJ + 1 (-1) 1 Fb^2/EJ$$

$$= (1/2 b - 1/4 b) Fb 1/EJ + 1 (-1) 1 Fb^2/EJ = -3/4 Fb^2/EJ$$

$$L_{DE}^{xo} = \int_0^b (1/2 + 1/2 x/b - x^2/b^2) Fb 1/EJ dx = [1/2 x + 1/4 x^2/b - 1/3 x^3/b^2]_0^b Fb 1/EJ$$

$$= (1/2 b + 1/4 b - 1/3 b) Fb 1/EJ = 5/12 Fb^2/EJ$$

$$L_{ED}^{xo} = \int_0^b (3/2 x/b - x^2/b^2) Fb 1/EJ dx = [3/4 x^2/b - 1/3 x^3/b^2]_0^b Fb 1/EJ$$

$$= (3/4 b - 1/3 b) Fb 1/EJ = 5/12 Fb^2/EJ$$

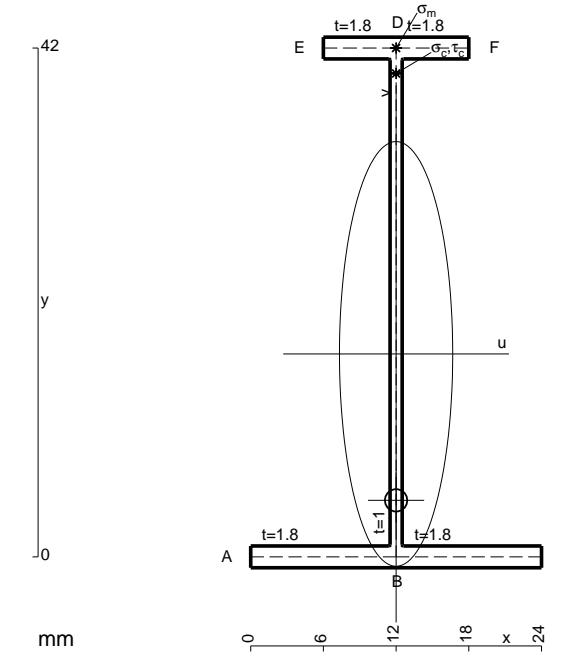

- A = 106.8 mm²
- J_u = 32824. mm⁴
- J_v = 2333. mm⁴
- J_t = 83.98 mm⁴
- y_o = -12.09 mm
- y_g = 16.75 mm
- N = -420. N
- T_y = -420. N
- M_x = -285600. Nmm
- x_m = 12. mm
- y_m = 42. mm
- v_m = 25.25 mm
- σ_m = N/A-Mv/J_u = 215.7 N/mm²
- y_c = 2. mm
- u_c = -12. mm
- v_c = -14.75 mm
- σ_c = N/A-Mv/J_u = 215.7 N/mm²
- τ_c = TS¹/tJ_u = 6.978 N/mm²
- τ_g = TS¹/tJ_u = 6.978 N/mm²
- t_c = 210. mm
- σ_o = √σ²+3τ² = 216.1 N/mm²

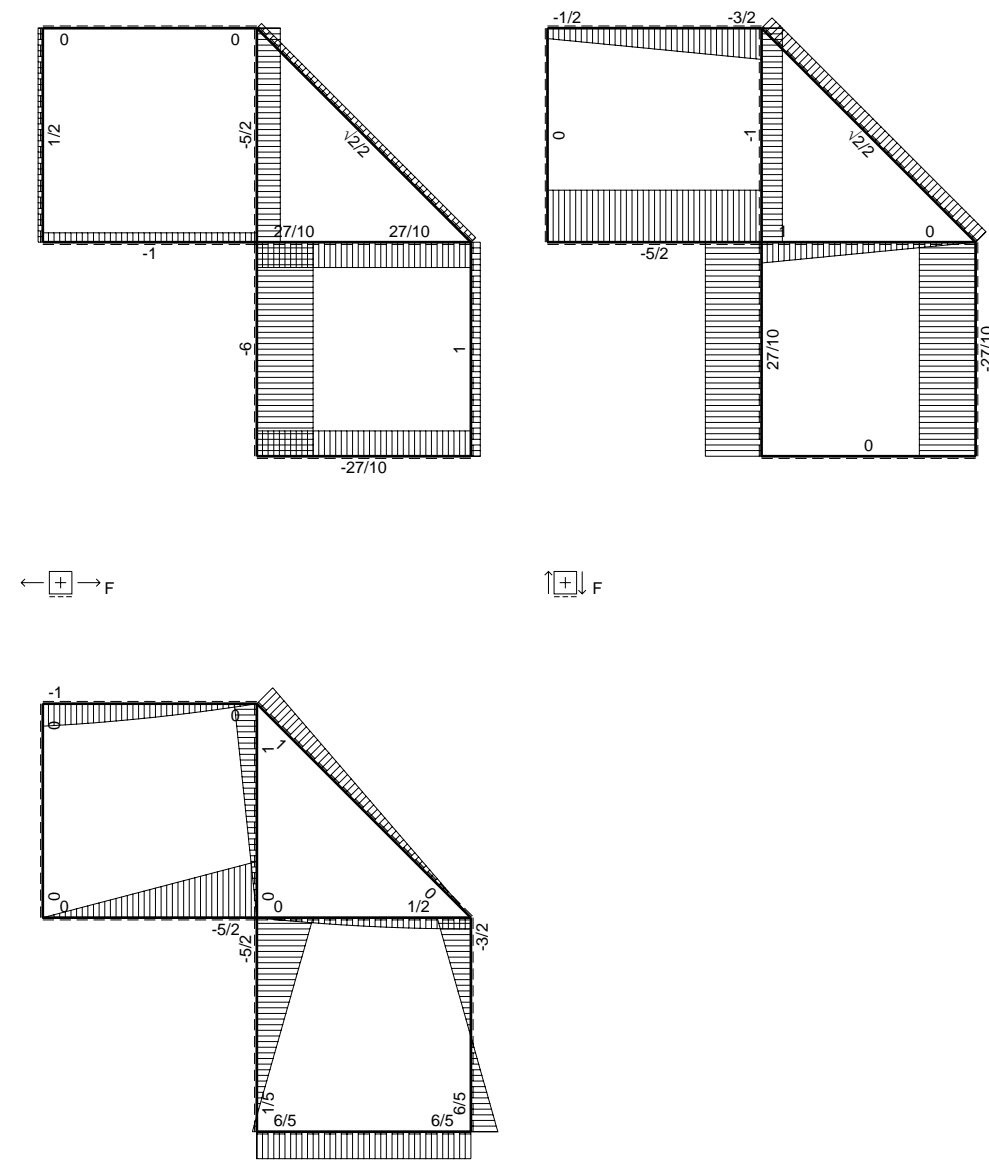
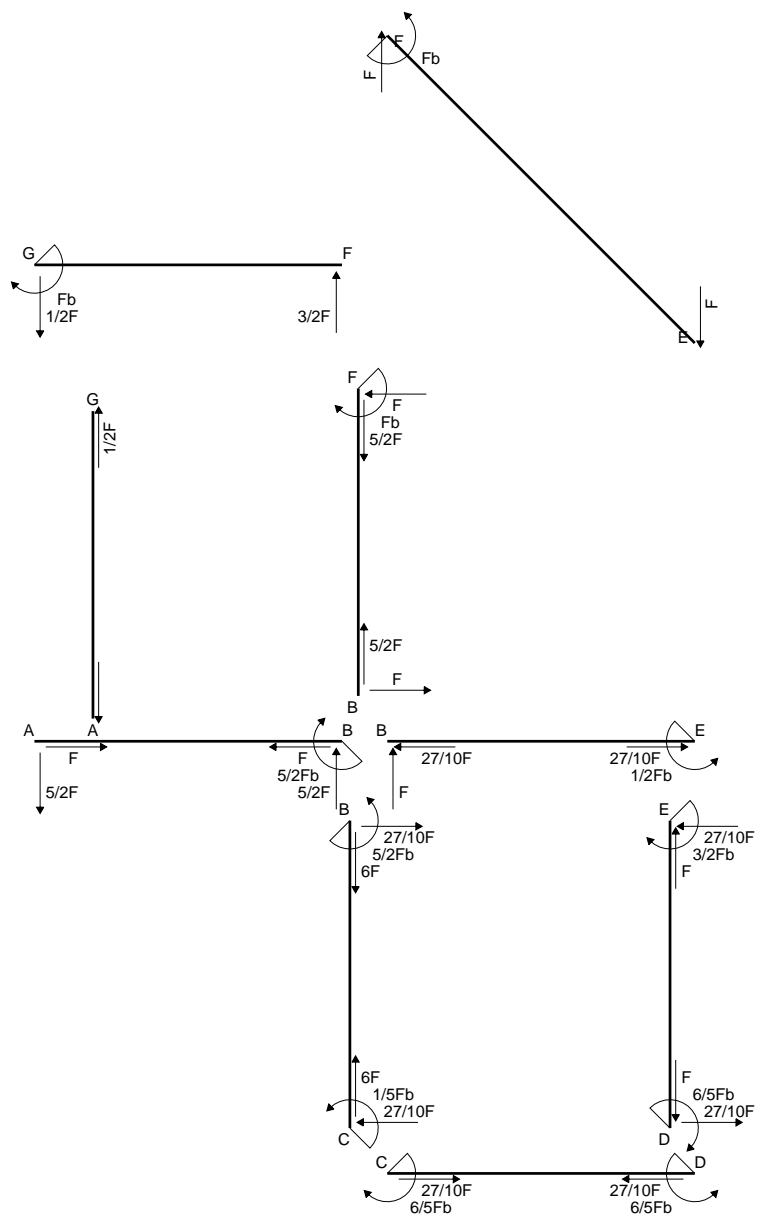

$\left[\begin{array}{c} + \\ - \end{array} \right] F_b$

$$L_{BC}^{xx} = \int_0^b (x^2/b^2) 1/EJ dx = [1/3 x^3/b^2]_0^b 1/EJ$$

$$= (1/3 b) 1/EJ = 1/3 b/EJ$$

$$L_{CB}^{xx} = \int_0^b (1 - 2x/b + x^2/b^2) 1/EJ dx = [x - x^2/b + 1/3 x^3/b^2]_0^b 1/EJ$$

$$= (b - b + 1/3 b) 1/EJ = 1/3 b/EJ$$

$$L_{CD}^{xx} = \int_0^b (1) 1/EJ dx = [x]_0^b 1/EJ$$

$$= (b) 1/EJ = b/EJ$$

$$L_{DC}^{xx} = \int_0^b (1) 1/EJ dx = [x]_0^b 1/EJ$$

$$= (b) 1/EJ = b/EJ$$

$$L_{DE}^{xx} = \int_0^b (1 - 2x/b + x^2/b^2) 1/EJ dx = [x - x^2/b + 1/3 x^3/b^2]_0^b 1/EJ$$

$$= (b - b + 1/3 b) 1/EJ = 1/3 b/EJ$$

$$L_{ED}^{xx} = \int_0^b (x^2/b^2) 1/EJ dx = [1/3 x^3/b^2]_0^b 1/EJ$$

$$= (1/3 b) 1/EJ = 1/3 b/EJ$$

$$L_{BC}^{x_0} = \int_0^b (5/2 x/b - 3/2 x^2/b^2) Fb 1/EJ dx = [5/4 x^2/b - 1/2 x^3/b^2]_0^b Fb 1/EJ$$

$$= (5/4 b - 1/2 b) Fb 1/EJ = 3/4 Fb^2/EJ$$

$$L_{CB}^{x_0} = \int_0^b (1 + 1/2 x/b - 3/2 x^2/b^2) Fb 1/EJ dx = [x + 1/4 x^2/b - 1/2 x^3/b^2]_0^b Fb 1/EJ$$

$$= (b + 1/4 b - 1/2 b) Fb 1/EJ = 3/4 Fb^2/EJ$$

$$L_{DE}^{x_0} = \int_0^b (3/2 x/b - 3/2 x^2/b^2) Fb 1/EJ dx = [3/4 x^2/b - 1/2 x^3/b^2]_0^b Fb 1/EJ$$

$$= (3/4 b - 1/2 b) Fb 1/EJ = 1/4 Fb^2/EJ$$

$$L_{ED}^{x_0} = \int_0^b (3/2 x/b - 3/2 x^2/b^2) Fb 1/EJ dx = [3/4 x^2/b - 1/2 x^3/b^2]_0^b Fb 1/EJ$$

$$= (3/4 b - 1/2 b) Fb 1/EJ = 1/4 Fb^2/EJ$$

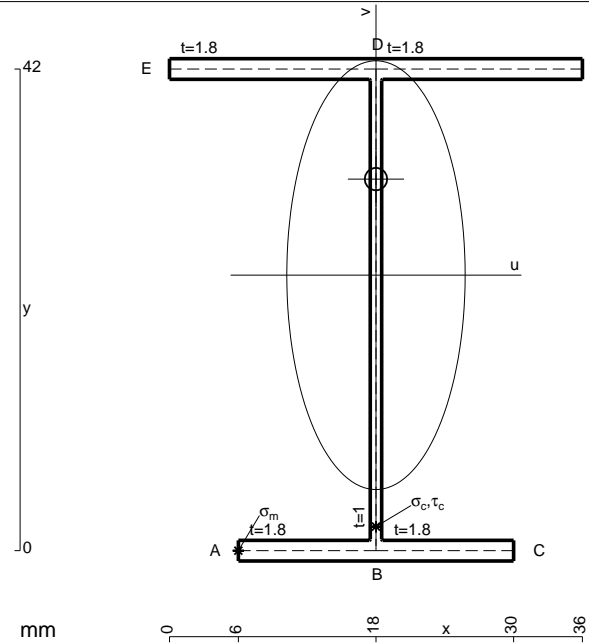

- A = 150. mm²
- J_u = 52430. mm⁴
- J_v = 9072. mm⁴
- J_I = 130.6 mm⁴
- y_o = 8.376 mm
- y_g = 24.02 mm
- N = -270. N
- T_y = -675. N
- M_x = -486000. Nmm
- x_m = 6. mm
- u_m = -12. mm
- v_m = -24.02 mm
- σ_m = N/A-Mv/J_u = -224.5 N/mm²
- x_c = 18. mm
- v_c = -24.02 mm
- σ_c = N/A-Mv/J_u = -224.5 N/mm²
- τ_c = TS'/tJ_u = 13.36 N/mm²
- τ_g = TS'/tJ_u = 13.36 N/mm²
- t_c = 270. mm
- σ_o = √σ²+3τ² = 225.7 N/mm²

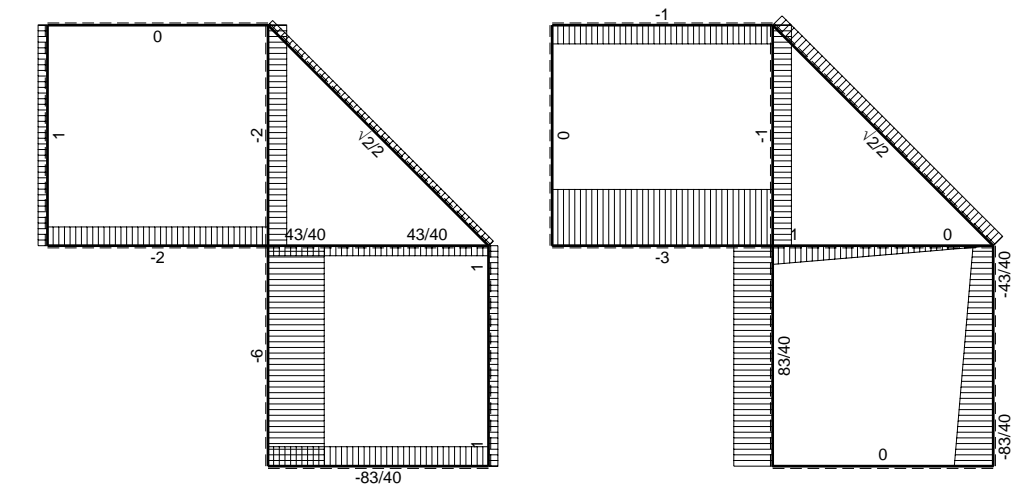
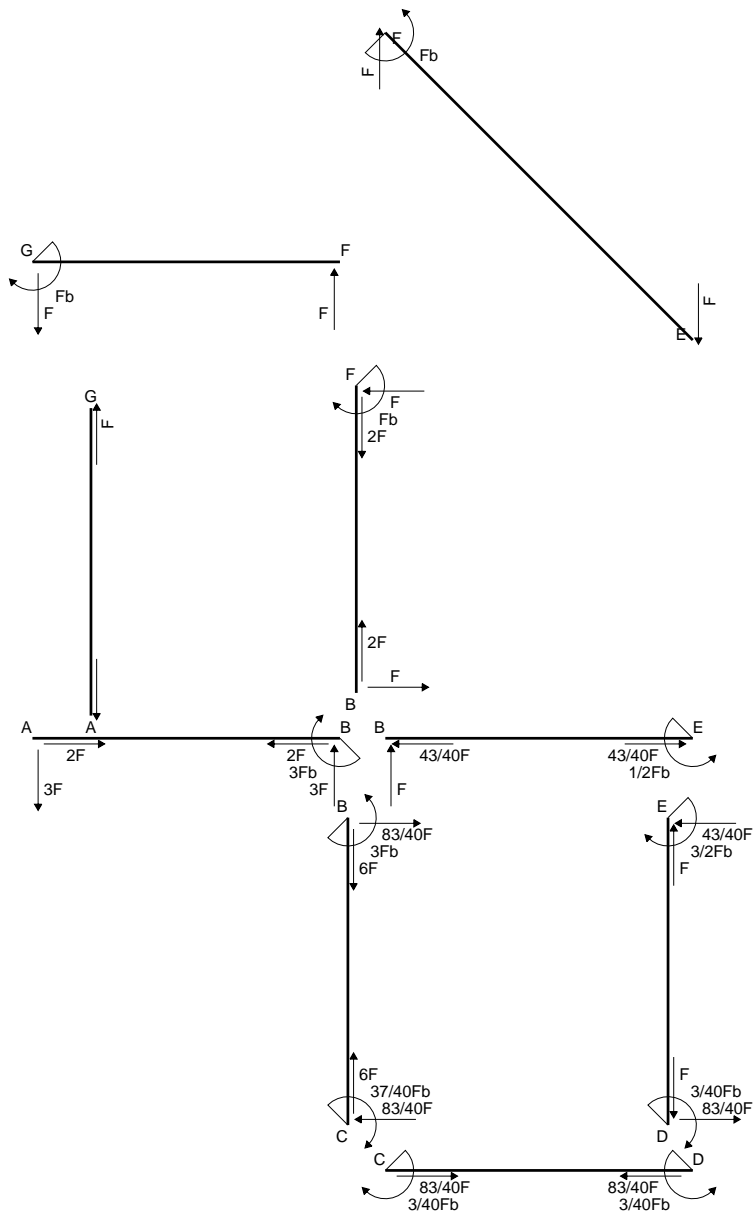

← (+) → F

↑ (+) ↓ F

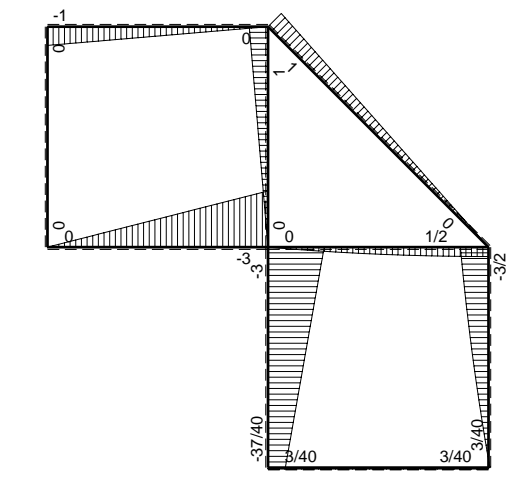

⤵ (+) ⤴ Fb

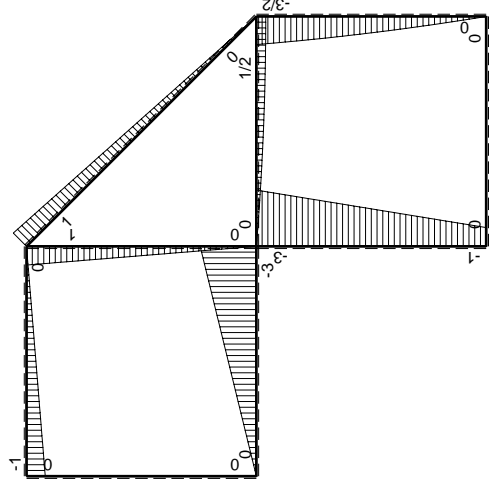
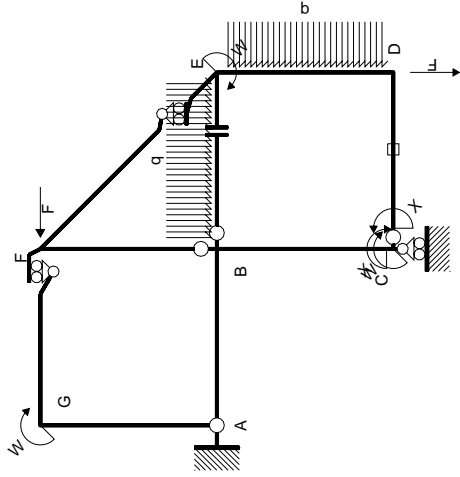

Schema di calcolo iperstatico

M_0 flessione da carichi assegnati

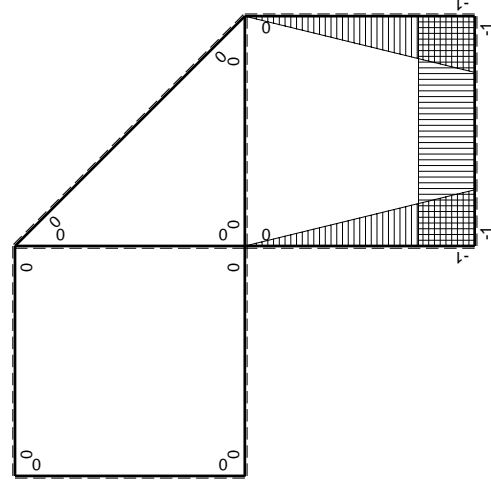

M_x flessione da iperstatica $X=1$

Quadro contribuiti PLV per iperstatica $X=W_{cd}$

\rightarrow	$M_x(x)$	$M_0(x)$	$M_x M_0$	$M_x M_x$	$\int M_x M_0 / EJ dx$	$\int M_x M_x / EJ dx$
AB b	0	-3Fx	0	0	0	0
BA b	0	3Fb-3Fx	0	0	0	0
BC b	-x/b	-3Fb+2Fx	3Fx-2Fx ² /b	x ² /b ²	5/6Fb ² /EJ	1/3Xb/EJ
CB b	1-x/b	Fb+2Fx	Fb+Fx-2Fx ² /b	1-2x/b+x ² /b ²	0	Xb/EJ
CD b	-1	0	0	1	0	Xb/EJ
DC b	1	0	0	1	0	Xb/EJ
DE b	-1+x/b	-2Fx+1/2qx ²	2Fx-5/2Fx ² /b+1/2qx ³ /b	1-2x/b+x ² /b ²	7/24Fb ² /EJ	1/3Xb/EJ
ED b	x/b	3/2Fb-Fx-1/2qx ²	3/2Fx-Fx ² /b-1/2qx ³ /b	x ² /b ²	0	0
EF $\sqrt{2}b$	0	$\sqrt{2}/2Fx$	0	0	0	0
FG b	0	-Fx	0	0	0	0
GF b	0	Fb-Fx	0	0	0	0
GA b	0	0	0	0	0	0
AG b	0	0	0	0	0	0
FB b	0	Fb-Fx	0	0	0	0
BF b	0	-Fx	0	0	0	0
BE b	0	Fx-1/2qx ²	0	0	0	0
EB b	0	-1/2Fb+1/2qx ²	0	0	0	0
CD	elongazione asta $N_{1,cd} \epsilon_{cd} L_{cd}$				-Fb ² /EJ	
	totali				1/8Fb ² /EJ	5/3Xb/EJ
	iperstatica $X=W_{cd}$				-3/40Fb	

Sviluppi di calcolo iperstatica

$$L_{BC}^{xx} = \int_0^b (x^2/b^2) 1/EJ dx = [1/3 x^3/b^2]_0^b 1/EJ$$

$$= (1/3 b) 1/EJ = 1/3 b/EJ$$

$$L_{CB}^{xx} = \int_0^b (1 - 2x/b + x^2/b^2) 1/EJ dx = [x - x^2/b + 1/3 x^3/b^2]_0^b 1/EJ$$

$$= (b - b + 1/3 b) 1/EJ = 1/3 b/EJ$$

$$L_{CD}^{xx} = \int_0^b (1) 1/EJ dx = [x]_0^b 1/EJ$$

$$= (b) 1/EJ = b/EJ$$

$$L_{DC}^{xx} = \int_0^b (1) 1/EJ dx = [x]_0^b 1/EJ$$

$$= (b) 1/EJ = b/EJ$$

$$L_{DE}^{xx} = \int_0^b (1 - 2x/b + x^2/b^2) 1/EJ dx = [x - x^2/b + 1/3 x^3/b^2]_0^b 1/EJ$$

$$= (b - b + 1/3 b) 1/EJ = 1/3 b/EJ$$

$$L_{ED}^{xx} = \int_0^b (x^2/b^2) 1/EJ dx = [1/3 x^3/b^2]_0^b 1/EJ$$

$$= (1/3 b) 1/EJ = 1/3 b/EJ$$

$$L_{BC}^{x_0} = \int_0^b (3x/b - 2x^2/b^2) Fb 1/EJ dx = [3/2 x^2/b - 2/3 x^3/b^2]_0^b Fb 1/EJ$$

$$= (3/2 b - 2/3 b) Fb 1/EJ = 5/6 Fb^2/EJ$$

$$L_{CB}^{x_0} = \int_0^b (1 + x/b - 2x^2/b^2) Fb 1/EJ dx = [x + 1/2 x^2/b - 2/3 x^3/b^2]_0^b Fb 1/EJ$$

$$= (b + 1/2 b - 2/3 b) Fb 1/EJ = 5/6 Fb^2/EJ$$

$$L_{DE}^{x_0} = \int_0^b (2x/b - 5/2 x^2/b^2 + 1/2 x^3/b^3) Fb 1/EJ dx = [x^2/b - 5/6 x^3/b^2 + 1/8 x^4/b^3]_0^b Fb 1/EJ$$

$$= (b - 5/6 b + 1/8 b) Fb 1/EJ = 7/24 Fb^2/EJ$$

$$L_{ED}^{x_0} = \int_0^b (3/2 x/b - x^2/b^2 - 1/2 x^3/b^3) Fb 1/EJ dx = [3/4 x^2/b - 1/3 x^3/b^2 - 1/8 x^4/b^3]_0^b Fb 1/EJ$$

$$= (3/4 b - 1/3 b - 1/8 b) Fb 1/EJ = 7/24 Fb^2/EJ$$

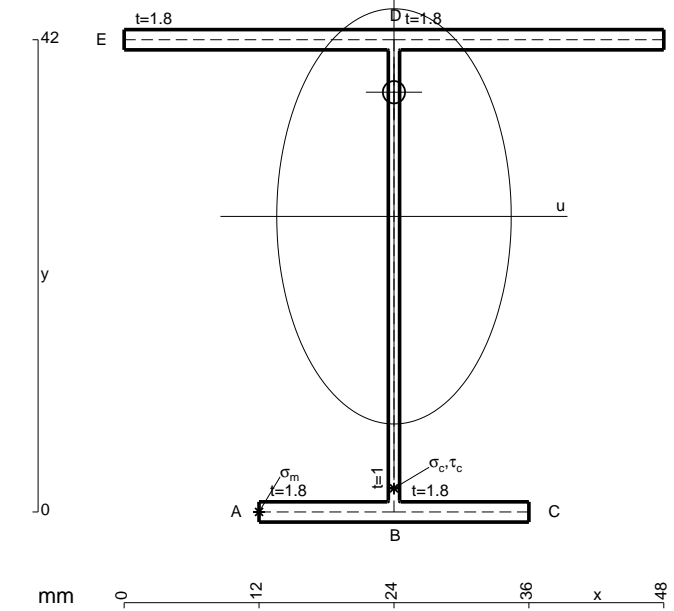

- A = 171.6 mm²
- J_u = 58532. mm⁴
- J_v = 18662. mm⁴
- J_t = 154. mm⁴
- y_o = 11.05 mm
- y_g = 26.29 mm
- N = -460. N
- T_y = -690. N
- M_x = -524400. Nmm
- x_m = 12. mm
- u_m = -12. mm
- v_m = -26.29 mm
- σ_m = N/A-Mv/J_u = -238.2 N/mm²
- x_c = 24. mm
- v_c = -26.29 mm
- σ_c = N/A-Mv/J_u = -238.2 N/mm²
- τ_c = TS'/tJ_u = 13.39 N/mm²
- τ_g = TS'/tJ_u = 13.39 N/mm²
- t_c = 230. mm
- σ_o = √σ²+3τ² = 239.3 N/mm²

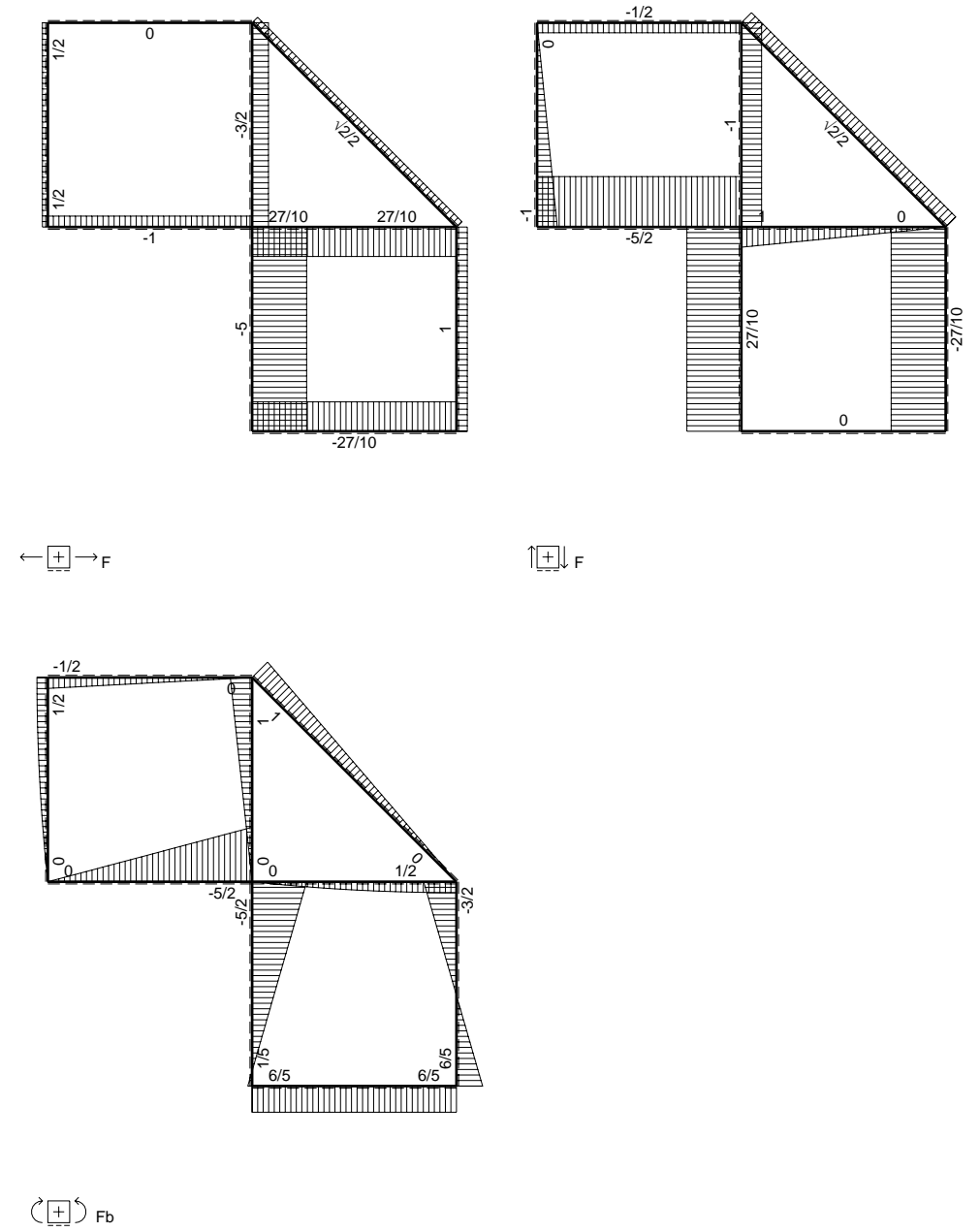
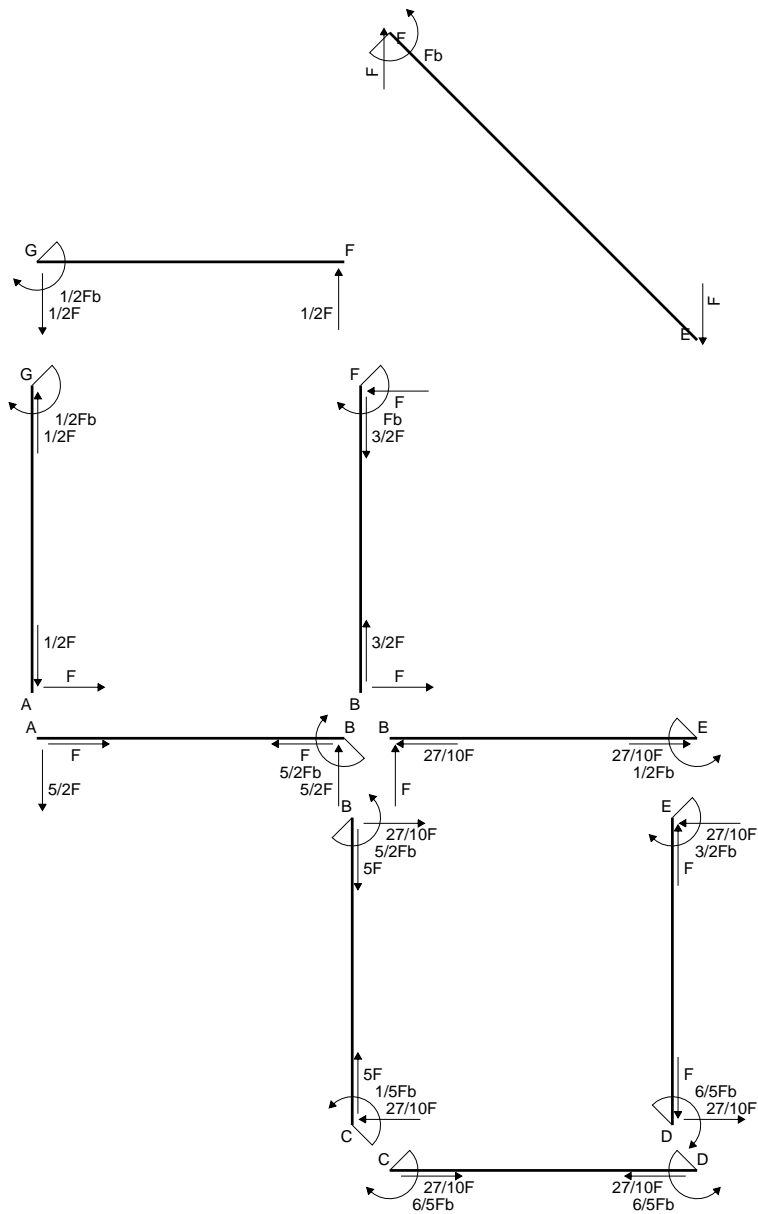

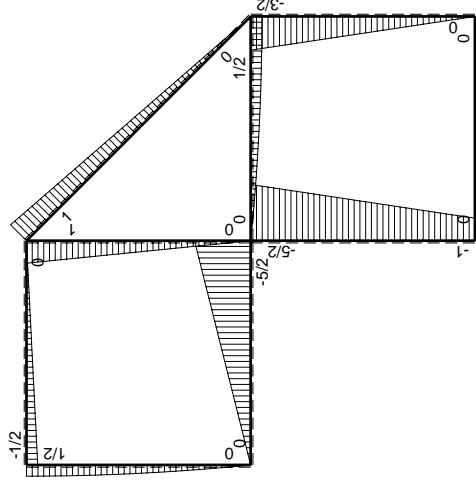
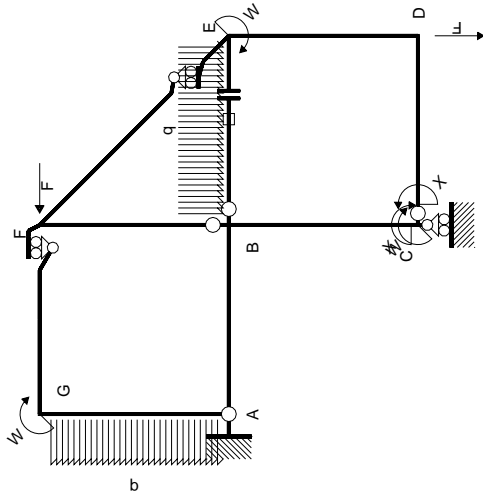

Schema di calcolo iperstatico

M_0 flessione da carichi assegnati

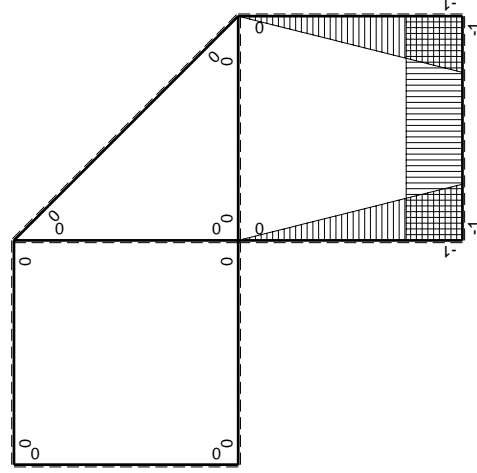

M_x flessione da iperstatica X=1

Quadro contribuiti PLV per iperstatica X=W_{CD}

→	$M_x(x)$	$M_0(x)$	$M_x M_0$	$M_x M_x$	$\int M_x M_0 / EJ dx$	$\int X M_x M_x / EJ dx$
AB b	0	-5/2Fx	0	0	0	0
BA b	0	5/2Fb-5/2Fx	0	0	0	0
BC b	-x/b	-5/2Fb+3/2Fx	5/2Fx-3/2Fx ² /b	x ² /b ²	3/4Fb ² /EJ	1/3Xb/EJ
CB b	1-x/b	Fb+3/2Fx	Fb+1/2Fx-3/2Fx ² /b	1-2x/b+x ² /b ²	0	Xb/EJ
CD b	-1	0	0	1	0	0
DC b	1	0	0	1	0	0
DE b	-1+x/b	-3/2Fx	3/2Fx-3/2Fx ² /b	1-2x/b+x ² /b ²	1/4Fb ² /EJ	1/3Xb/EJ
ED b	x/b	3/2Fb-3/2Fx	3/2Fx-3/2Fx ² /b	x ² /b ²	0	0
EF √2b	0	√2/2Fx	0	0	0	0
FG b	0	-1/2Fx	0	0	0	0
GF b	0	1/2Fb-1/2Fx	0	0	0	0
GA b	0	1/2Fb-1/2qx ²	0	0	0	0
AG b	0	-Fx+1/2qx ²	0	0	0	0
FB b	0	Fb-Fx	0	0	0	0
BF b	0	-Fx	0	0	0	0
BE b	0	Fx-1/2qx ²	0	0	0	0
EB b	0	-1/2Fb+1/2qx ²	0	0	0	0
BE	elongazione asta $N_{1, BE} \epsilon_{BE} = L_{BE}$				Fb ² /EJ	
	totali				2Fb ² /EJ	5/3Xb/EJ
	iperstatica X=W _{CD}				-6/5Fb	

Sviluppi di calcolo iperstatica

$$L_{BC}^{xx} = \int_0^b (x^2/b^2) 1/EJ dx = [1/3 x^3/b^2]_0^b 1/EJ$$

$$= (1/3 b) 1/EJ = 1/3 b/EJ$$

$$L_{CB}^{xx} = \int_0^b (1 - 2x/b + x^2/b^2) 1/EJ dx = [x - x^2/b + 1/3 x^3/b^2]_0^b 1/EJ$$

$$= (b - b + 1/3 b) 1/EJ = 1/3 b/EJ$$

$$L_{CD}^{xx} = \int_0^b (1) 1/EJ dx = [x]_0^b 1/EJ$$

$$= (b) 1/EJ = b/EJ$$

$$L_{DC}^{xx} = \int_0^b (1) 1/EJ dx = [x]_0^b 1/EJ$$

$$= (b) 1/EJ = b/EJ$$

$$L_{DE}^{xx} = \int_0^b (1 - 2x/b + x^2/b^2) 1/EJ dx = [x - x^2/b + 1/3 x^3/b^2]_0^b 1/EJ$$

$$= (b - b + 1/3 b) 1/EJ = 1/3 b/EJ$$

$$L_{ED}^{xx} = \int_0^b (x^2/b^2) 1/EJ dx = [1/3 x^3/b^2]_0^b 1/EJ$$

$$= (1/3 b) 1/EJ = 1/3 b/EJ$$

$$L_{BC}^{xo} = \int_0^b (5/2 x/b - 3/2 x^2/b^2) Fb 1/EJ dx = [5/4 x^2/b - 1/2 x^3/b^2]_0^b Fb 1/EJ$$

$$= (5/4 b - 1/2 b) Fb 1/EJ = 3/4 Fb^2/EJ$$

$$L_{CB}^{xo} = \int_0^b (1 + 1/2 x/b - 3/2 x^2/b^2) Fb 1/EJ dx = [x + 1/4 x^2/b - 1/2 x^3/b^2]_0^b Fb 1/EJ$$

$$= (b + 1/4 b - 1/2 b) Fb 1/EJ = 3/4 Fb^2/EJ$$

$$L_{DE}^{xo} = \int_0^b (3/2 x/b - 3/2 x^2/b^2) Fb 1/EJ dx = [3/4 x^2/b - 1/2 x^3/b^2]_0^b Fb 1/EJ$$

$$= (3/4 b - 1/2 b) Fb 1/EJ = 1/4 Fb^2/EJ$$

$$L_{ED}^{xo} = \int_0^b (3/2 x/b - 3/2 x^2/b^2) Fb 1/EJ dx = [3/4 x^2/b - 1/2 x^3/b^2]_0^b Fb 1/EJ$$

$$= (3/4 b - 1/2 b) Fb 1/EJ = 1/4 Fb^2/EJ$$

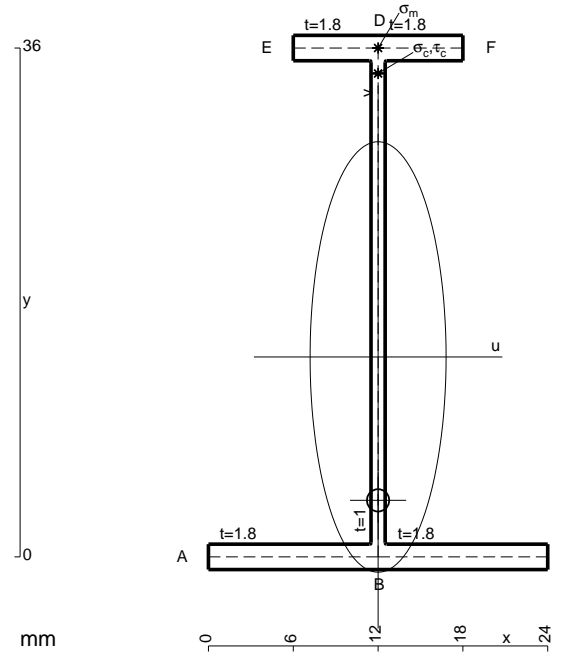

- A = 100.8 mm²
- J_u = 23384. mm⁴
- J_v = 2333. mm⁴
- J_t = 81.98 mm⁴
- y_o = -10.14 mm
- y_g = 14.14 mm
- N = -250. N
- T_y = -625. N
- M_x = -212500. Nmm
- x_m = 12. mm
- y_m = 36. mm
- v_m = 21.86 mm
- σ_m = N/A-Mv/J_u = 196.1 N/mm²
- y_c = 2. mm
- u_c = -12. mm
- v_c = -12.14 mm
- σ_c = N/A-Mv/J_u = 196.1 N/mm²
- τ_c = TS/tJ_u = 12.62 N/mm²
- τ_g = TS/tJ_u = 12.62 N/mm²
- t_c = 250. mm
- σ_o = √σ²+3τ² = 197.4 N/mm²

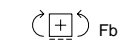
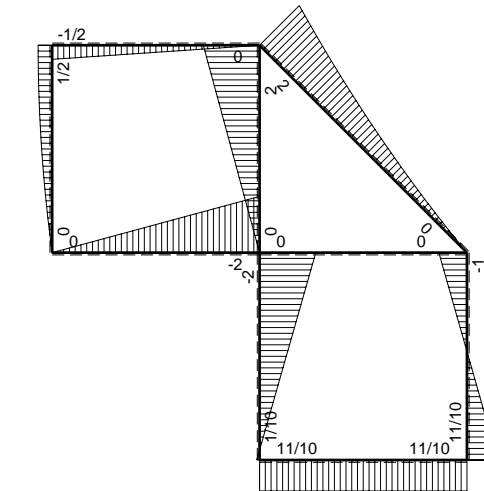
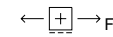
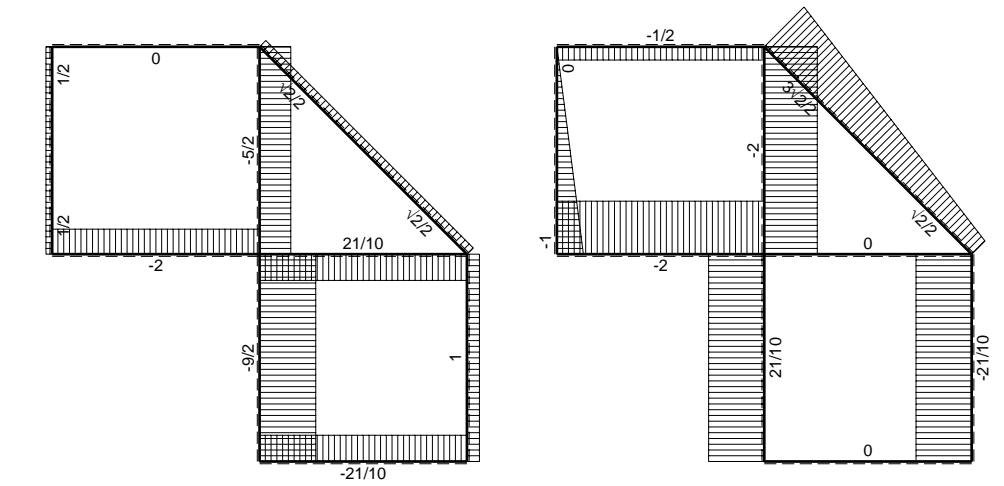
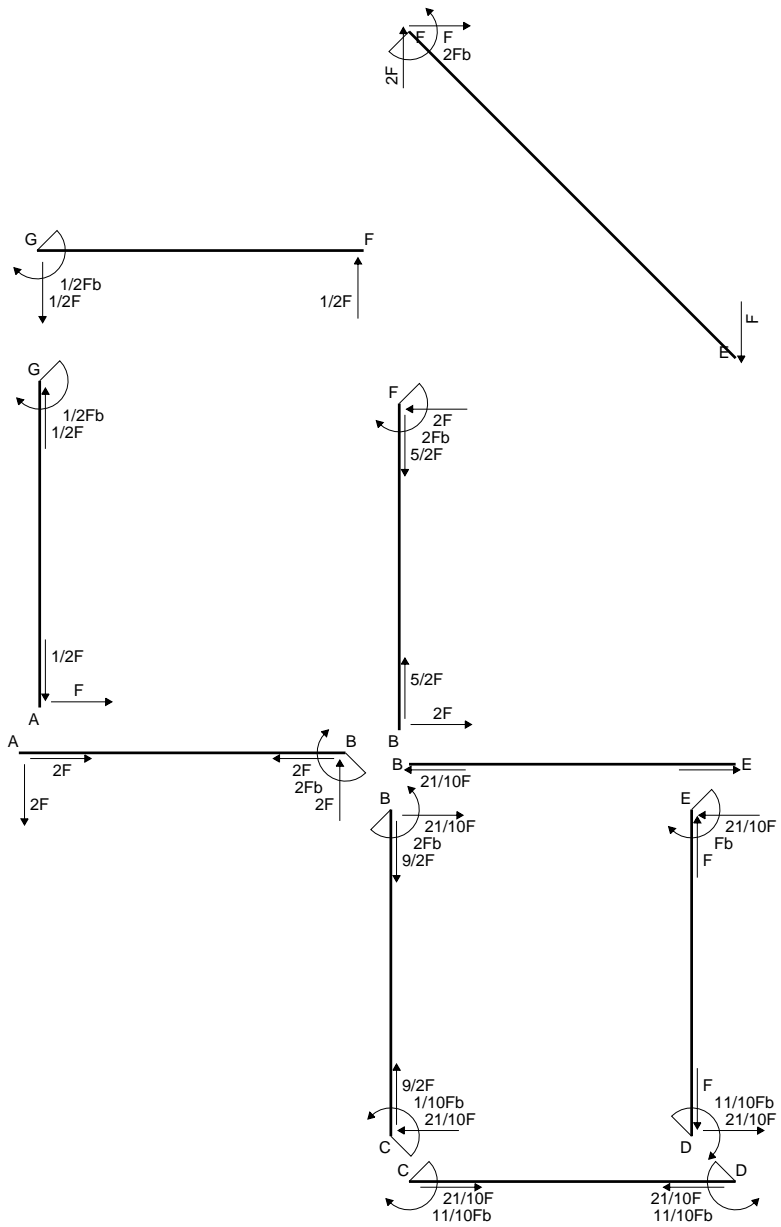

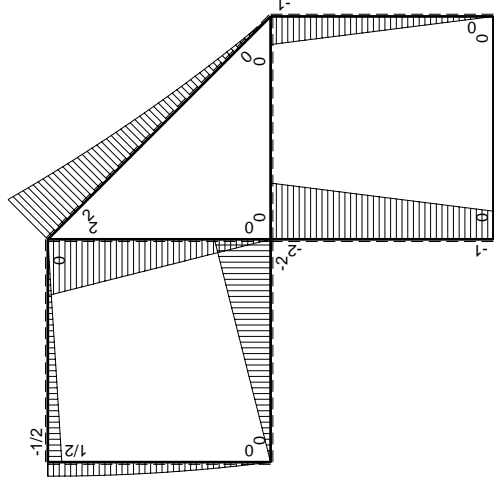
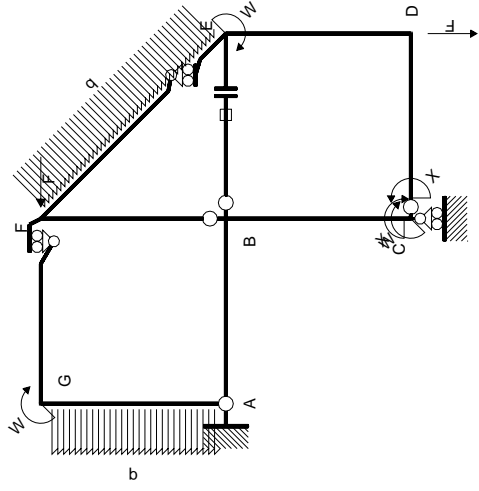

Schema di calcolo iperstatico

M_0 flessione da carichi assegnati

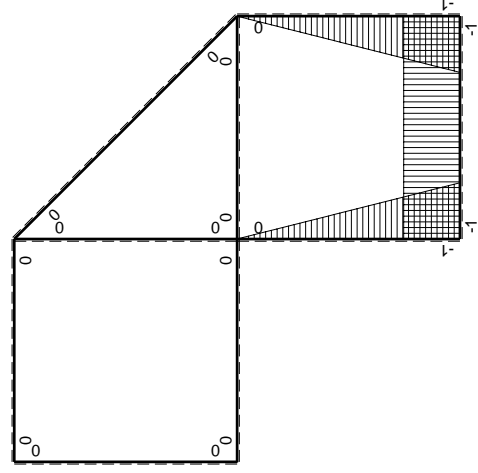

M_x flessione da iperstatica $X=1$

Quadro contribuiti PLV per iperstatica $X=W_{cd}$

\rightarrow	$M_x(x)$	$M_0(x)$	$M_x M_0$	$M_x M_x$	$\int M_x M_0 / E J dx$	$\int M_x M_x / E J dx$
AB b	0	-2Fx	0	0	0	0
BA b	0	2Fb-2Fx	0	0	0	0
BC b	-x/b	-2Fb+Fx	2Fx-Fx ² /b	x ² /b ²	2/3Fb ² /EJ	1/3Xb/EJ
CB b	1-x/b	Fb+Fx	Fb-Fx ² /b	1-2x/b+x ² /b ²		
CD b	-1	0	0	1	0	Xb/EJ
DC b	1	0	0	1	0	
DE b	-1+x/b	-Fx	Fx-Fx ² /b	1-2x/b+x ² /b ²	1/6Fb ² /EJ	1/3Xb/EJ
ED b	x/b	Fb-Fx	Fx-Fx ² /b	x ² /b ²		
EF $\sqrt{2}b$	0	$\sqrt{2}/2Fx+1/2qx^2$	0	0	0	0
FG b	0	-1/2Fx	0	0	0	0
GF b	0	1/2Fb-1/2Fx	0	0	0	0
GA b	0	1/2Fb-1/2qx ²	0	0	0	0
AG b	0	-Fx+1/2qx ²	0	0	0	0
FB b	0	2Fb-2Fx	0	0	0	0
BF b	0	-2Fx	0	0	0	0
BE b	0	0	0	0	0	0
EB b	0	0	0	0	0	0
BE	elongazione asta $N_{1, BE} \epsilon_{BE} L_{BE}$				Fb ² /EJ	
	totali				11/6Fb ² /EJ	5/3Xb/EJ
	iperstatica $X=W_{cd}$					-11/10Fb

Sviluppi di calcolo iperstatica

$$L_{BC}^{xx} = \int_0^b (x^2/b^2) 1/EJ dx = [1/3 x^3/b^2]_0^b 1/EJ$$

$$= (1/3 b) 1/EJ = 1/3 b/EJ$$

$$L_{CB}^{xx} = \int_0^b (1 - 2x/b + x^2/b^2) 1/EJ dx = [x - x^2/b + 1/3 x^3/b^2]_0^b 1/EJ$$

$$= (b - b + 1/3 b) 1/EJ = 1/3 b/EJ$$

$$L_{CD}^{xx} = \int_0^b (1) 1/EJ dx = [x]_0^b 1/EJ$$

$$= (b) 1/EJ = b/EJ$$

$$L_{DC}^{xx} = \int_0^b (1) 1/EJ dx = [x]_0^b 1/EJ$$

$$= (b) 1/EJ = b/EJ$$

$$L_{DE}^{xx} = \int_0^b (1 - 2x/b + x^2/b^2) 1/EJ dx = [x - x^2/b + 1/3 x^3/b^2]_0^b 1/EJ$$

$$= (b - b + 1/3 b) 1/EJ = 1/3 b/EJ$$

$$L_{ED}^{xx} = \int_0^b (x^2/b^2) 1/EJ dx = [1/3 x^3/b^2]_0^b 1/EJ$$

$$= (1/3 b) 1/EJ = 1/3 b/EJ$$

$$L_{BC}^{xo} = \int_0^b (2x/b - x^2/b^2) Fb 1/EJ dx = [x^2/b - 1/3 x^3/b^2]_0^b Fb 1/EJ$$

$$= (b - 1/3 b) Fb 1/EJ = 2/3 Fb^2/EJ$$

$$L_{CB}^{xo} = \int_0^b (1 - x^2/b^2) Fb 1/EJ dx = [x - 1/3 x^3/b^2]_0^b Fb 1/EJ$$

$$= (b - 1/3 b) Fb 1/EJ = 2/3 Fb^2/EJ$$

$$L_{DE}^{xo} = \int_0^b (x/b - x^2/b^2) Fb 1/EJ dx = [1/2 x^2/b - 1/3 x^3/b^2]_0^b Fb 1/EJ$$

$$= (1/2 b - 1/3 b) Fb 1/EJ = 1/6 Fb^2/EJ$$

$$L_{ED}^{xo} = \int_0^b (x/b - x^2/b^2) Fb 1/EJ dx = [1/2 x^2/b - 1/3 x^3/b^2]_0^b Fb 1/EJ$$

$$= (1/2 b - 1/3 b) Fb 1/EJ = 1/6 Fb^2/EJ$$

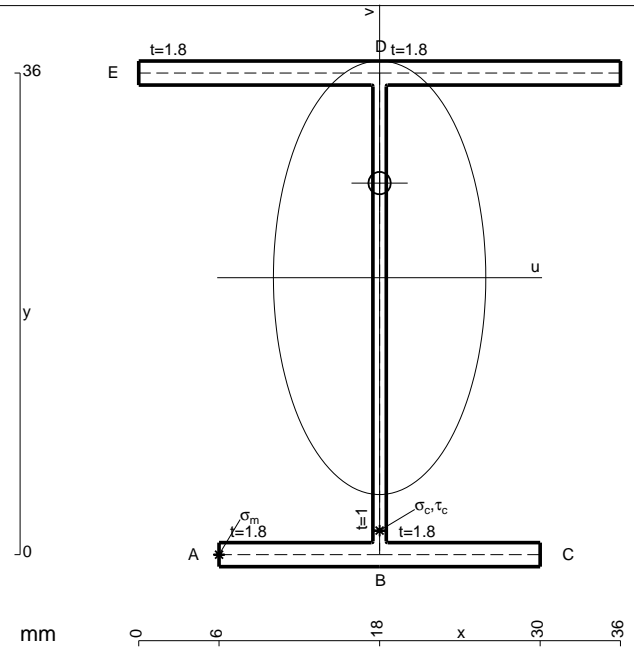

- A = 144. mm²
- J_u = 37830. mm⁴
- J_v = 9072. mm⁴
- J_t = 128.6 mm⁴
- y_o = 7.071 mm
- y_g = 20.7 mm
- N = 360.6 N
- T_y = 1082. N
- M_x = 377400. Nmm
- x_m = 6. mm
- u_m = -12. mm
- v_m = -20.7 mm
- σ_m = N/A-Mv/J_u = 209. N/mm²
- x_c = 18. mm
- v_c = -20.7 mm
- σ_c = N/A-Mv/J_u = 209. N/mm²
- τ_c = TS_t/J_u = 25.57 N/mm²
- τ_g = TS_t/J_u = 25.57 N/mm²
- t_c = 510. mm
- σ_o = √σ²+3τ² = 213.7 N/mm²

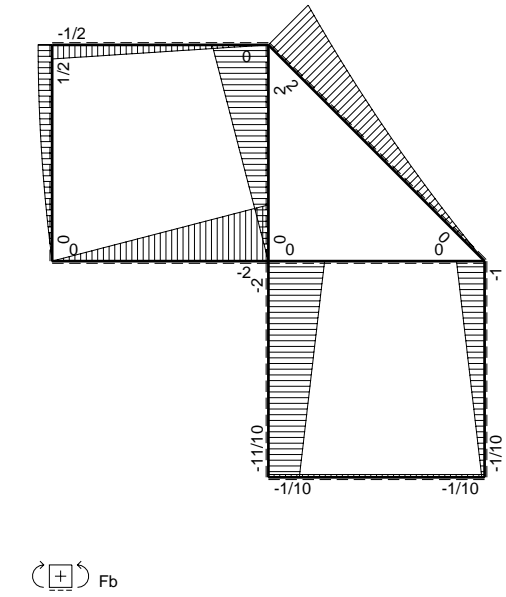
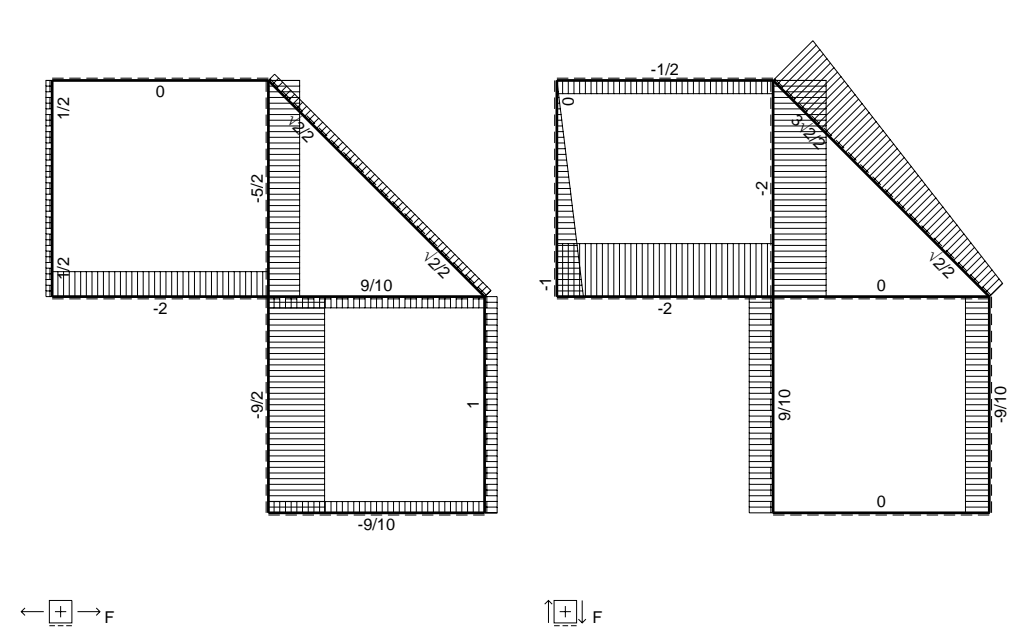
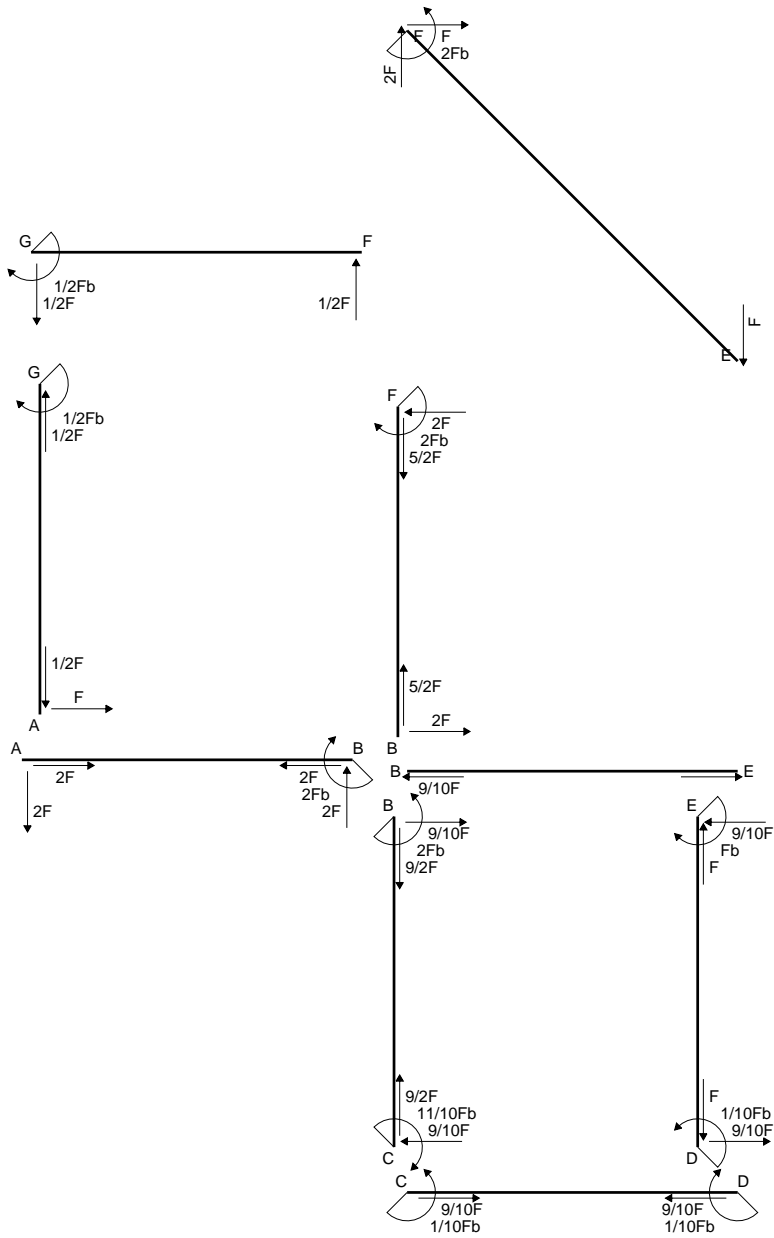

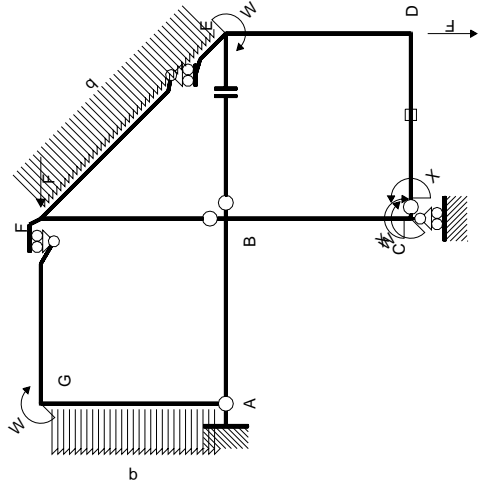

Schema di calcolo iperstatico

M_0 flessione da carichi assegnati

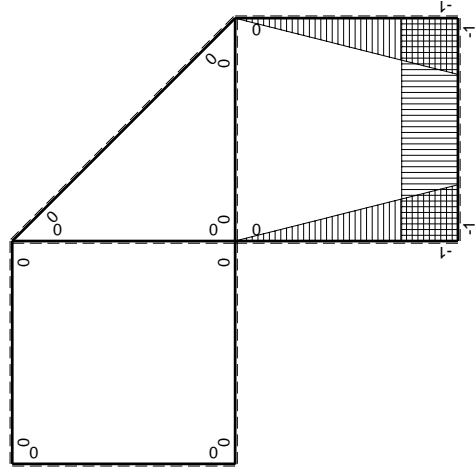

M_x flessione da iperstatica $X=1$

Quadro contribuiti PLV per iperstatica $X=W_{cd}$

\rightarrow	$M_x(x)$	$M_0(x)$	$M_x M_0$	$M_x M_x$	$\int M_x M_0 / EJ dx$	$\int M_x M_x / EJ dx$
AB b	0	-2Fx	0	0	0	0
BA b	0	2Fb-2Fx	0	0	0	0
BC b	-x/b	-2Fb+Fx	$2Fx-Fx^2/b$	x^2/b^2	$2/3Fb^2/EJ$	$1/3Xb/EJ$
CB b	1-x/b	Fb+Fx	$Fb-Fx^2/b$	$1-2x/b+x^2/b^2$	0	Xb/EJ
CD b	-1	0	0	1	0	0
DC b	1	0	0	1	0	0
DE b	-1+x/b	-Fx	$Fx-Fx^2/b$	$1-2x/b+x^2/b^2$	$1/6Fb^2/EJ$	$1/3Xb/EJ$
ED b	x/b	Fb-Fx	$Fx-Fx^2/b$	x^2/b^2	0	0
EF $\sqrt{2}b$	0	$\sqrt{2}/2Fx+1/2qx^2$	0	0	0	0
FG b	0	-1/2Fx	0	0	0	0
GF b	0	$1/2Fb-1/2Fx$	0	0	0	0
GA b	0	$1/2Fb-1/2qx^2$	0	0	0	0
AG b	0	$-Fx+1/2qx^2$	0	0	0	0
FB b	0	2Fb-2Fx	0	0	0	0
BF b	0	-2Fx	0	0	0	0
BE b	0	0	0	0	0	0
EB b	0	0	0	0	0	0
CD	elongazione asta $N_{1,cd} \epsilon_{cd} L_{cd}$				$-Fb^2/EJ$	
	totali				$-1/6Fb^2/EJ$	$5/3Xb/EJ$
	iperstatica $X=W_{cd}$				$1/10Fb$	

Sviluppi di calcolo iperstatica

$$L_{BC}^{xx} = \int_0^b (x^2/b^2) 1/EJ dx = [1/3 x^3/b^2]_0^b 1/EJ$$

$$= (1/3 b) 1/EJ = 1/3 b/EJ$$

$$L_{CB}^{xx} = \int_0^b (1 - 2x/b + x^2/b^2) 1/EJ dx = [x - x^2/b + 1/3 x^3/b^2]_0^b 1/EJ$$

$$= (b - b + 1/3 b) 1/EJ = 1/3 b/EJ$$

$$L_{CD}^{xx} = \int_0^b (1) 1/EJ dx = [x]_0^b 1/EJ$$

$$= (b) 1/EJ = b/EJ$$

$$L_{DC}^{xx} = \int_0^b (1) 1/EJ dx = [x]_0^b 1/EJ$$

$$= (b) 1/EJ = b/EJ$$

$$L_{DE}^{xx} = \int_0^b (1 - 2x/b + x^2/b^2) 1/EJ dx = [x - x^2/b + 1/3 x^3/b^2]_0^b 1/EJ$$

$$= (b - b + 1/3 b) 1/EJ = 1/3 b/EJ$$

$$L_{ED}^{xx} = \int_0^b (x^2/b^2) 1/EJ dx = [1/3 x^3/b^2]_0^b 1/EJ$$

$$= (1/3 b) 1/EJ = 1/3 b/EJ$$

$$L_{BC}^{xo} = \int_0^b (2x/b - x^2/b^2) Fb 1/EJ dx = [x^2/b - 1/3 x^3/b^2]_0^b Fb 1/EJ$$

$$= (b - 1/3 b) Fb 1/EJ = 2/3 Fb^2/EJ$$

$$L_{CB}^{xo} = \int_0^b (1 - x^2/b^2) Fb 1/EJ dx = [x - 1/3 x^3/b^2]_0^b Fb 1/EJ$$

$$= (b - 1/3 b) Fb 1/EJ = 2/3 Fb^2/EJ$$

$$L_{DE}^{xo} = \int_0^b (x/b - x^2/b^2) Fb 1/EJ dx = [1/2 x^2/b - 1/3 x^3/b^2]_0^b Fb 1/EJ$$

$$= (1/2 b - 1/3 b) Fb 1/EJ = 1/6 Fb^2/EJ$$

$$L_{ED}^{xo} = \int_0^b (x/b - x^2/b^2) Fb 1/EJ dx = [1/2 x^2/b - 1/3 x^3/b^2]_0^b Fb 1/EJ$$

$$= (1/2 b - 1/3 b) Fb 1/EJ = 1/6 Fb^2/EJ$$

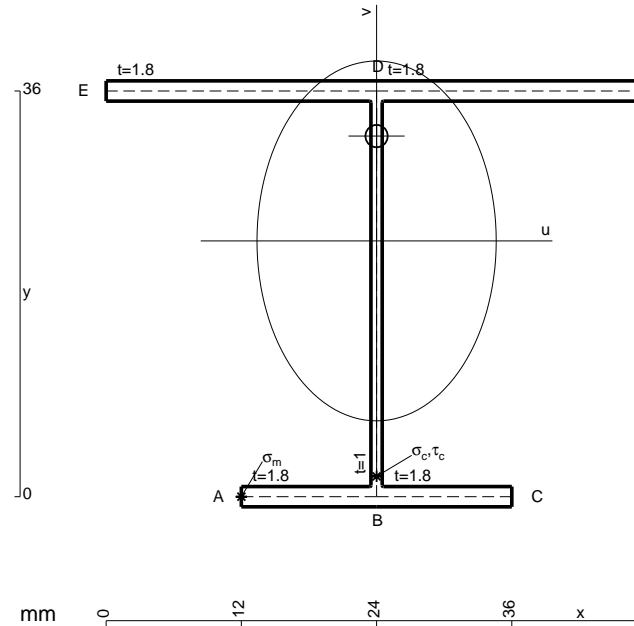

- A = 165.6 mm²
- J_u = 42227. mm⁴
- J_v = 18662. mm⁴
- J_t = 152. mm⁴
- y_o = 9.304 mm
- y_g = 22.7 mm
- N = 353.6 N
- T_y = 1061. N
- M_x = 400000. Nmm
- x_m = 12. mm
- u_m = -12. mm
- v_m = -22.7 mm
- σ_m = N/A-Mv/J_u = 217.1 N/mm²
- x_c = 24. mm
- v_c = -22.7 mm
- σ_c = N/A-Mv/J_u = 217.1 N/mm²
- τ_c = TS^{*}/tJ_u = 24.63 N/mm²
- τ_g = TS^{*}/tJ_u = 24.63 N/mm²
- t_c = 500. mm
- σ_o = √σ²+3τ² = 221.3 N/mm²

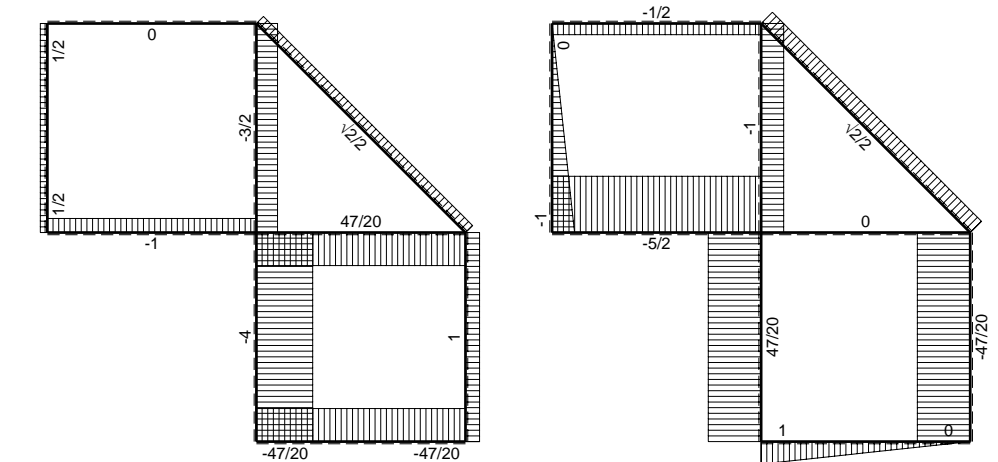
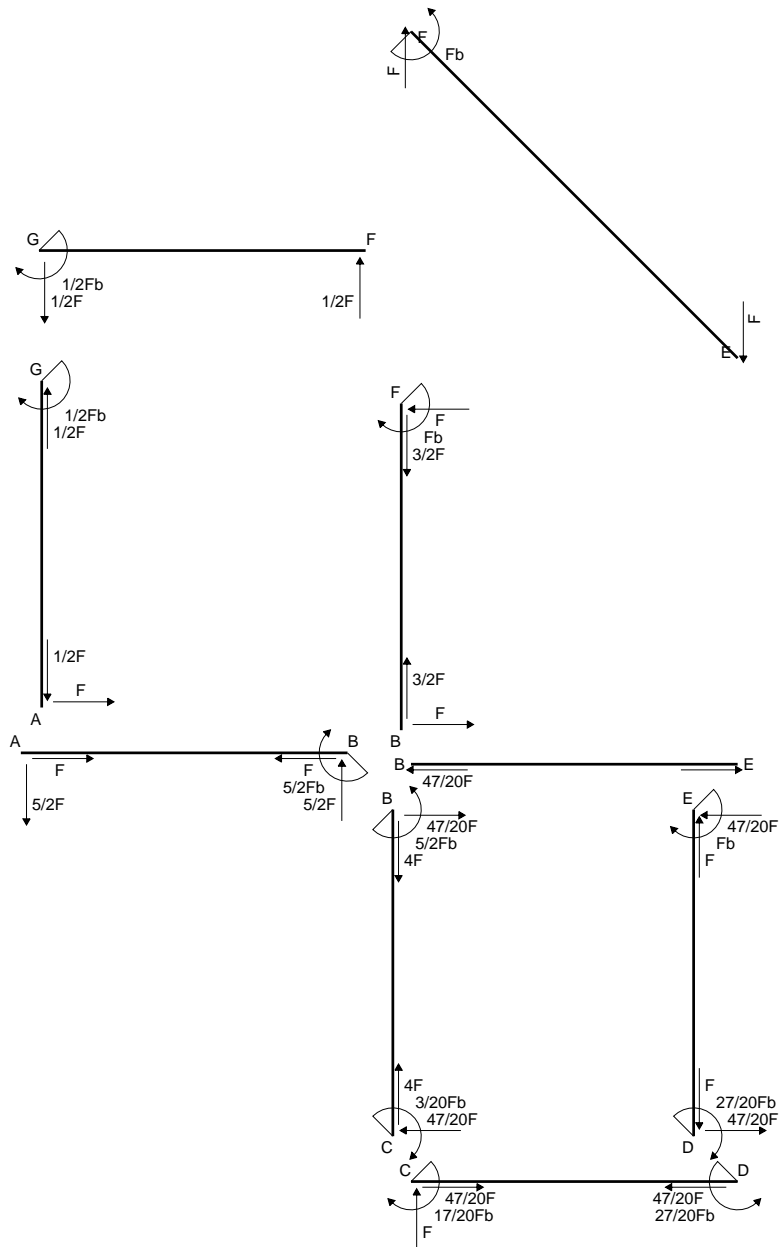

← ⊕ → F

↑ ⊕ ↓ F

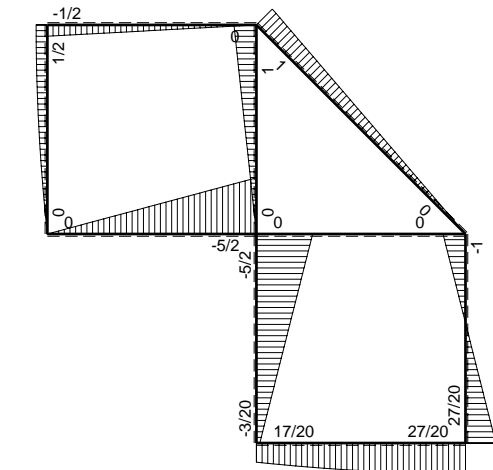

⊕ ⊖ F_b

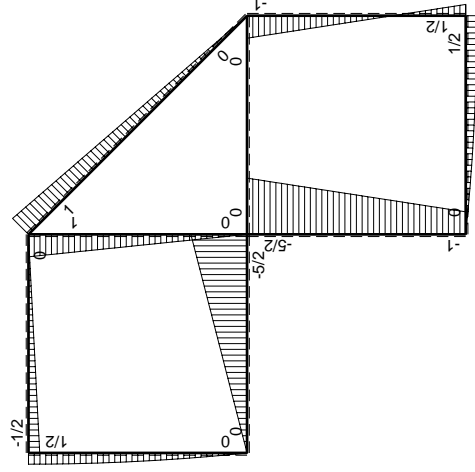
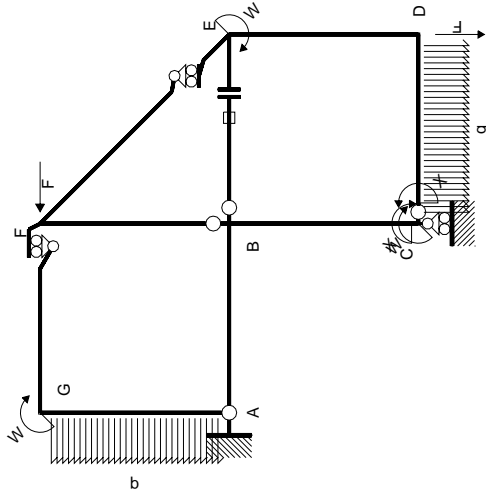

Schema di calcolo iperstatico

M_0 flessione da carichi assegnati

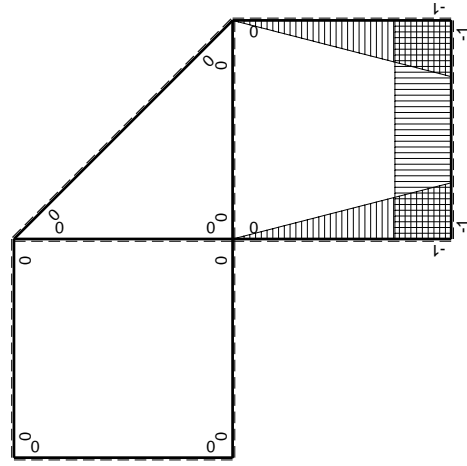

M_x flessione da iperstatica X=1

Quadro contributi PLV per iperstatica X=W_{cd}

→	$M_x(x)$	$M_0(x)$	$M_x M_0$	$M_x M_x$	$\int M_x M_0 / EJ dx$	$\int M_x M_x / EJ dx$
AB b	0	-5/2Fx	0	0	0	0
BA b	0	5/2Fb-5/2Fx	0	0	0	0
BC b	-x/b	-5/2Fb+3/2Fx	5/2Fx-3/2Fx ² /b	x ² /b ²	3/4Fb ² /EJ	1/3Xb/EJ
CB b	1-x/b	Fb+3/2Fx	Fb+1/2Fx-3/2Fx ² /b	1-2x/b+x ² /b ²	-1/3Fb ² /EJ	Xb/EJ
CD b	-1	Fx-1/2qx ²	-Fx+1/2Fx ² /b	1	-1/3Fb ² /EJ	Xb/EJ
DC b	1	-1/2Fb+1/2qx ²	-1/2Fb+1/2Fx ² /b	1	-1/3Fb ² /EJ	Xb/EJ
DE b	-1+x/b	1/2Fb-3/2Fx	-1/2Fb+2Fx-3/2Fx ² /b	1-2x/b+x ² /b ²	0	1/3Xb/EJ
ED b	x/b	Fb-3/2Fx	Fx-3/2Fx ² /b	x ² /b ²	0	1/3Xb/EJ
EF √2b	0	√2/2Fx	0	0	0	0
FG b	0	-1/2Fx	0	0	0	0
GF b	0	1/2Fb-1/2Fx	0	0	0	0
GA b	0	1/2Fb-1/2qx ²	0	0	0	0
AG b	0	-Fx+1/2qx ²	0	0	0	0
FB b	0	Fb-Fx	0	0	0	0
BF b	0	-Fx	0	0	0	0
BE b	0	0	0	0	0	0
EB b	0	0	0	0	0	0
BE	elongazione asta $N_{1, BE} \epsilon_{BE} L_{BE}$				Fb ² /EJ	
	totali				17/12Fb ² /EJ	5/3Xb/EJ
	iperstatica X=W _{cd}				-17/20Fb	

Sviluppi di calcolo iperstatica

$$L_{BC}^{xx} = \int_0^b (x^2/b^2) 1/EJ dx = [1/3 x^3/b^2]_0^b 1/EJ$$

$$= (1/3 b) 1/EJ = 1/3 b/EJ$$

$$L_{CB}^{xx} = \int_0^b (1 - 2x/b + x^2/b^2) 1/EJ dx = [x - x^2/b + 1/3 x^3/b^2]_0^b 1/EJ$$

$$= (b - b + 1/3 b) 1/EJ = 1/3 b/EJ$$

$$L_{CD}^{xx} = \int_0^b (1) 1/EJ dx = [x]_0^b 1/EJ$$

$$= (b) 1/EJ = b/EJ$$

$$L_{DC}^{xx} = \int_0^b (1) 1/EJ dx = [x]_0^b 1/EJ$$

$$= (b) 1/EJ = b/EJ$$

$$L_{DE}^{xx} = \int_0^b (1 - 2x/b + x^2/b^2) 1/EJ dx = [x - x^2/b + 1/3 x^3/b^2]_0^b 1/EJ$$

$$= (b - b + 1/3 b) 1/EJ = 1/3 b/EJ$$

$$L_{ED}^{xx} = \int_0^b (x^2/b^2) 1/EJ dx = [1/3 x^3/b^2]_0^b 1/EJ$$

$$= (1/3 b) 1/EJ = 1/3 b/EJ$$

$$L_{BC}^{x_0} = \int_0^b (5/2 x/b - 3/2 x^2/b^2) Fb 1/EJ dx = [5/4 x^2/b - 1/2 x^3/b^2]_0^b Fb 1/EJ$$

$$= (5/4 b - 1/2 b) Fb 1/EJ = 3/4 Fb^2/EJ$$

$$L_{CB}^{x_0} = \int_0^b (1 + 1/2 x/b - 3/2 x^2/b^2) Fb 1/EJ dx = [x + 1/4 x^2/b - 1/2 x^3/b^2]_0^b Fb 1/EJ$$

$$= (b + 1/4 b - 1/2 b) Fb 1/EJ = 3/4 Fb^2/EJ$$

$$L_{CD}^{x_0} = \int_0^b (-x/b + 1/2 x^2/b^2) Fb 1/EJ dx = [-1/2 x^2/b + 1/6 x^3/b^2]_0^b Fb 1/EJ$$

$$= (-1/2 b + 1/6 b) Fb 1/EJ = -1/3 Fb^2/EJ$$

$$L_{DC}^{x_0} = \int_0^b (-1/2 + 1/2 x^2/b^2) Fb 1/EJ dx = [-1/2 x + 1/6 x^3/b^2]_0^b Fb 1/EJ$$

$$= (-1/2 b + 1/6 b) Fb 1/EJ = -1/3 Fb^2/EJ$$

$$L_{DE}^{x_0} = \int_0^b (-1/2 + 2x/b - 3/2 x^2/b^2) Fb 1/EJ dx = [-1/2 x + x^2/b - 1/2 x^3/b^2]_0^b Fb 1/EJ$$

$$= (-1/2 b + b - 1/2 b) Fb 1/EJ = 0$$

$$L_{ED}^{x_0} = \int_0^b (x/b - 3/2 x^2/b^2) Fb 1/EJ dx = [1/2 x^2/b - 1/2 x^3/b^2]_0^b Fb 1/EJ$$

$$= (1/2 b - 1/2 b) Fb 1/EJ = 0$$

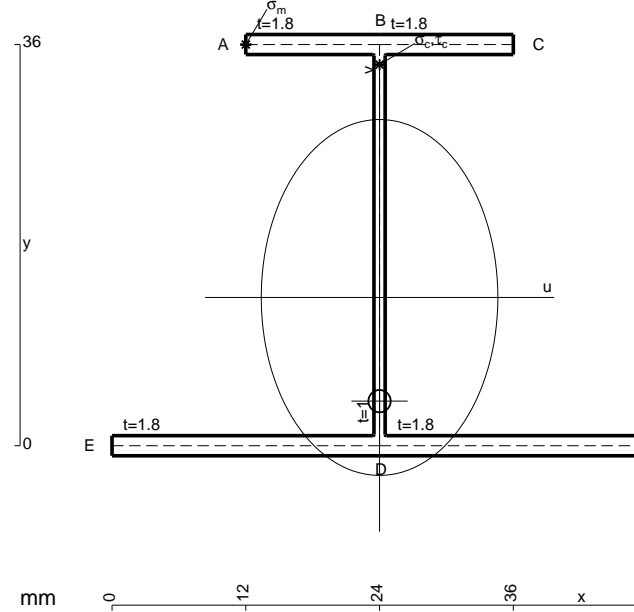

- A = 165.6 mm²
- J_u = 42227. mm⁴
- J_v = 18662. mm⁴
- J_t = 152. mm⁴
- y_o = -9.304 mm
- y_g = 13.3 mm
- N = -390. N
- T_y = -975. N
- M_x = -429000. Nmm
- x_m = 12. mm
- y_m = 36. mm
- u_m = -12. mm
- v_m = 22.7 mm
- σ_m = N/A - Mv/J_u = 228.2 N/mm²
- x_c = 24. mm
- y_c = 36. mm
- v_c = 22.7 mm
- σ_c = N/A - Mv/J_u = 228.2 N/mm²
- τ_c = TS_t/tJ_u = 22.64 N/mm²
- τ_g = TS_t/tJ_u = 22.64 N/mm²
- t_c = 390. mm
- σ_o = √σ² + 3τ² = 231.6 N/mm²

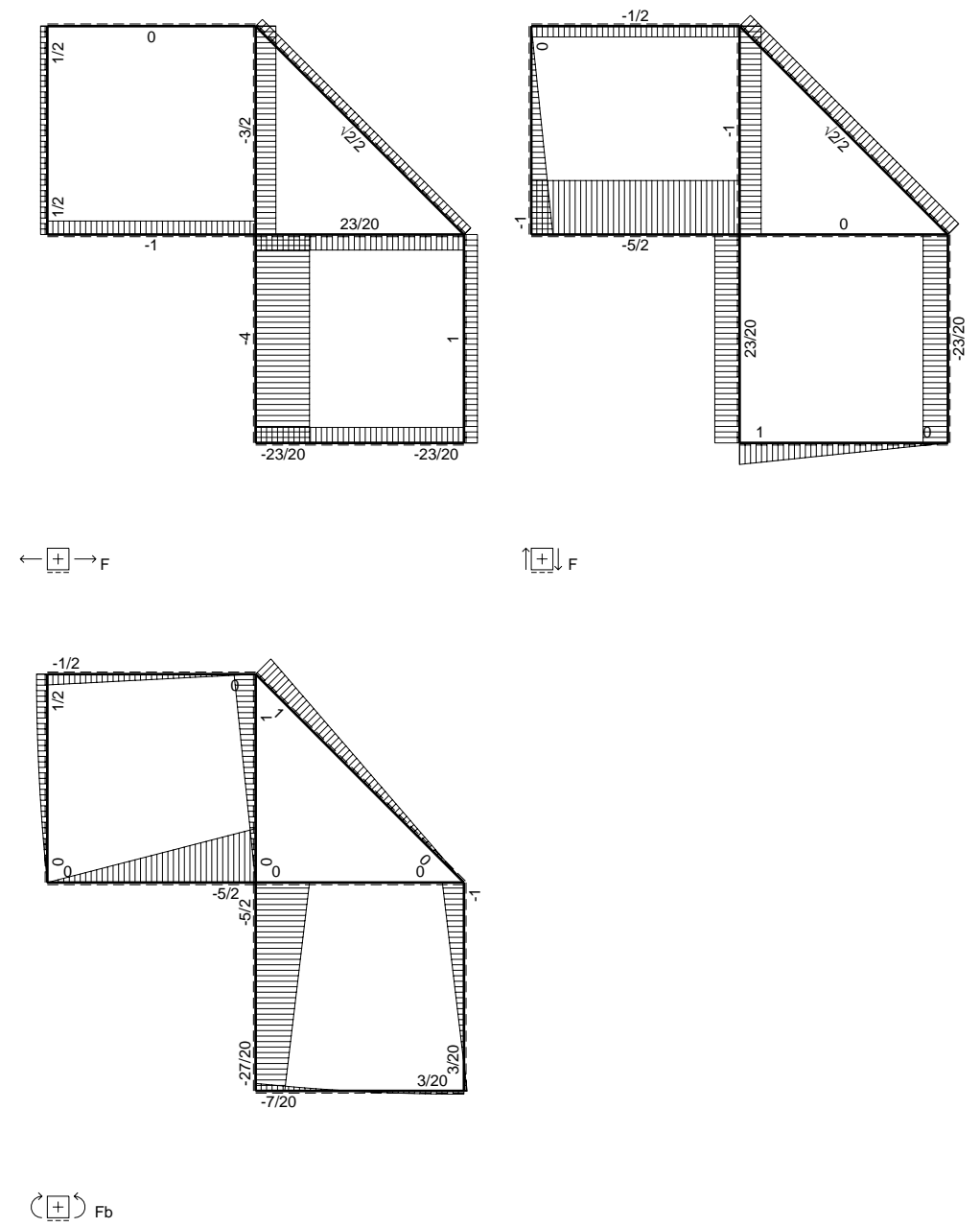
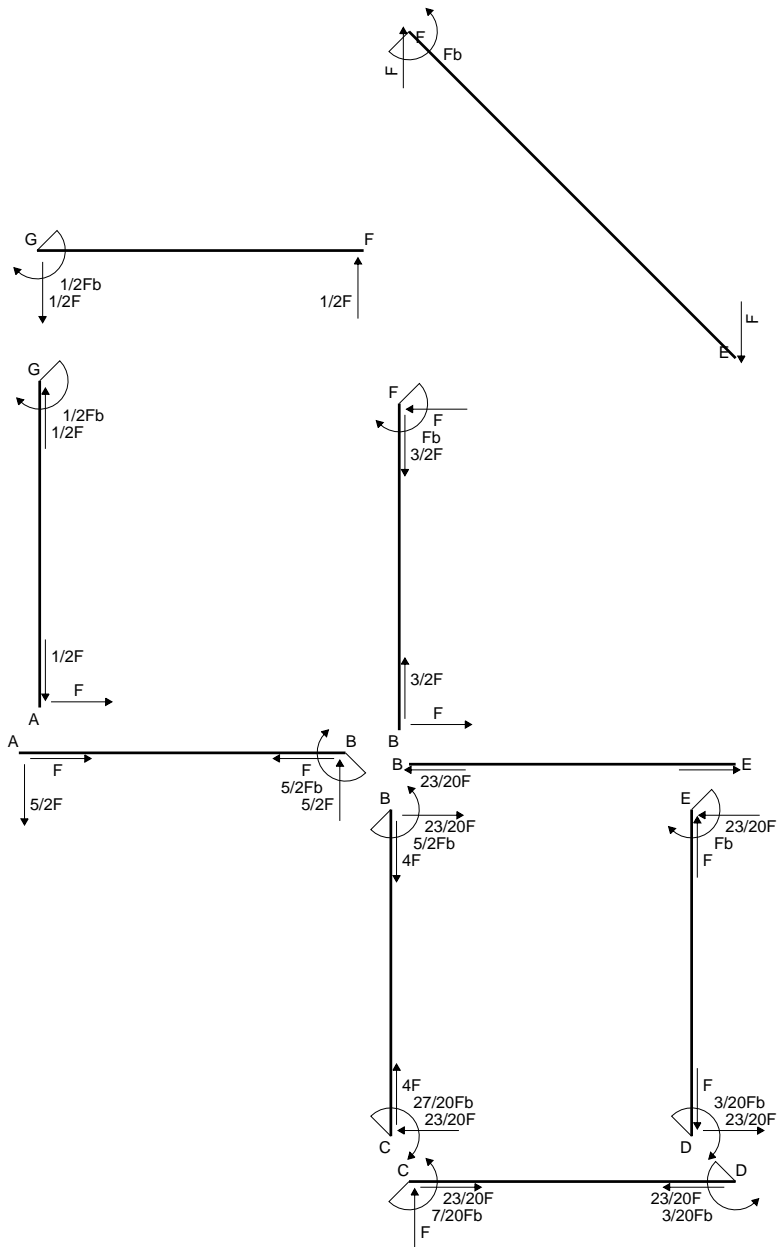

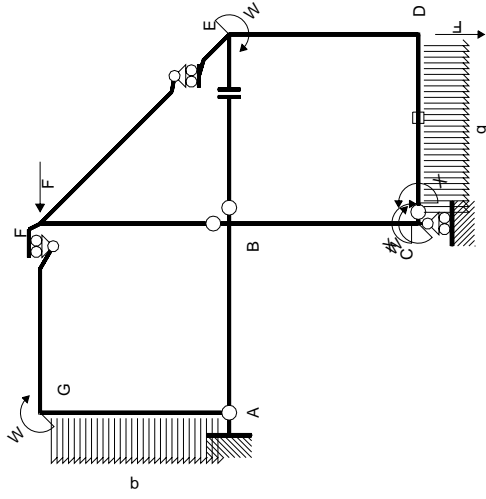

Schema di calcolo iperstatico

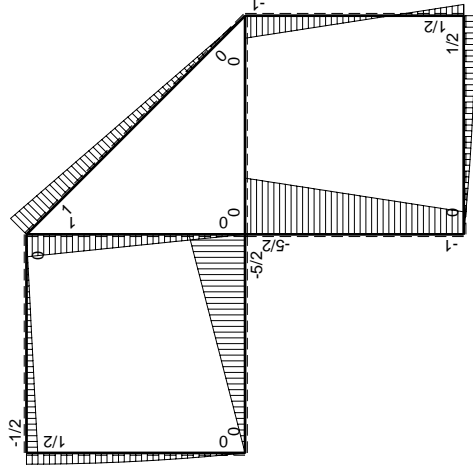

M₀ flessione da carichi assegnati

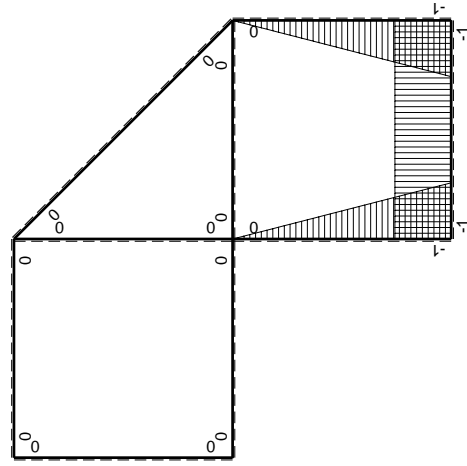

M_x flessione da iperstatica X=1

Quadro contribuiti PLV per iperstatica X=W_{cd}

→	M _x (x)	M ₀ (x)	M _x M ₀	M _x M _x	∫M _x M ₀ /EJdx	∫XM _x M _x /EJdx
AB b	0	-5/2Fx	0	0	0	0
BA b	0	5/2Fb-5/2Fx	0	0	0	0
BC b	-x/b	-5/2Fb+3/2Fx	5/2Fx-3/2Fx ² /b	x ² /b ²	3/4Fb ² /EJ	1/3Xb/EJ
CB b	1-x/b	Fb+3/2Fx	Fb+1/2Fx-3/2Fx ² /b	1-2x/b+x ² /b ²	-1/3Fb ² /EJ	Xb/EJ
CD b	-1	Fx-1/2qx ²	-Fx+1/2Fx ² /b	1	-1/3Fb ² /EJ	Xb/EJ
DC b	1	-1/2Fb+1/2qx ²	-1/2Fb+1/2Fx ² /b	1	-1/3Fb ² /EJ	Xb/EJ
DE b	-1+x/b	1/2Fb-3/2Fx	-1/2Fb+2Fx-3/2Fx ² /b	1-2x/b+x ² /b ²	0	1/3Xb/EJ
ED b	x/b	Fb-3/2Fx	Fx-3/2Fx ² /b	x ² /b ²	0	1/3Xb/EJ
EF √2b	0	√2/2Fx	0	0	0	0
FG b	0	-1/2Fx	0	0	0	0
GF b	0	1/2Fb-1/2Fx	0	0	0	0
GA b	0	1/2Fb-1/2qx ²	0	0	0	0
AG b	0	-Fx+1/2qx ²	0	0	0	0
FB b	0	Fb-Fx	0	0	0	0
BF b	0	-Fx	0	0	0	0
BE b	0	0	0	0	0	0
EB b	0	0	0	0	0	0
CD	elongazione asta N _{1,cd} ε _{cd} L _{cd}				-Fb ² /EJ	
	totali				-7/12Fb ² /EJ	5/3Xb/EJ
	iperstatica X=W _{cd}				7/20Fb	

Sviluppi di calcolo iperstatica

$$L_{BC}^{xx} = \int_0^b (x^2/b^2) 1/EJ dx = [1/3 x^3/b^2]_0^b 1/EJ$$

$$= (1/3 b) 1/EJ = 1/3 b/EJ$$

$$L_{CB}^{xx} = \int_0^b (1 - 2x/b + x^2/b^2) 1/EJ dx = [x - x^2/b + 1/3 x^3/b^2]_0^b 1/EJ$$

$$= (b - b + 1/3 b) 1/EJ = 1/3 b/EJ$$

$$L_{CD}^{xx} = \int_0^b (1) 1/EJ dx = [x]_0^b 1/EJ$$

$$= (b) 1/EJ = b/EJ$$

$$L_{DC}^{xx} = \int_0^b (1) 1/EJ dx = [x]_0^b 1/EJ$$

$$= (b) 1/EJ = b/EJ$$

$$L_{DE}^{xx} = \int_0^b (1 - 2x/b + x^2/b^2) 1/EJ dx = [x - x^2/b + 1/3 x^3/b^2]_0^b 1/EJ$$

$$= (b - b + 1/3 b) 1/EJ = 1/3 b/EJ$$

$$L_{ED}^{xx} = \int_0^b (x^2/b^2) 1/EJ dx = [1/3 x^3/b^2]_0^b 1/EJ$$

$$= (1/3 b) 1/EJ = 1/3 b/EJ$$

$$L_{BC}^{x_0} = \int_0^b (5/2 x/b - 3/2 x^2/b^2) Fb 1/EJ dx = [5/4 x^2/b - 1/2 x^3/b^2]_0^b Fb 1/EJ$$

$$= (5/4 b - 1/2 b) Fb 1/EJ = 3/4 Fb^2/EJ$$

$$L_{CB}^{x_0} = \int_0^b (1 + 1/2 x/b - 3/2 x^2/b^2) Fb 1/EJ dx = [x + 1/4 x^2/b - 1/2 x^3/b^2]_0^b Fb 1/EJ$$

$$= (b + 1/4 b - 1/2 b) Fb 1/EJ = 3/4 Fb^2/EJ$$

$$L_{CD}^{x_0} = \int_0^b (-x/b + 1/2 x^2/b^2) Fb 1/EJ dx + 1 (-1) 1 Fb^2/EJ$$

$$= [-1/2 x^2/b + 1/6 x^3/b^2]_0^b Fb 1/EJ + 1 (-1) 1 Fb^2/EJ$$

$$= (-1/2 b + 1/6 b) Fb 1/EJ + 1 (-1) 1 Fb^2/EJ = -4/3 Fb^2/EJ$$

$$L_{DC}^{x_0} = \int_0^b (-1/2 + 1/2 x^2/b^2) Fb 1/EJ dx + 1 (-1) 1 Fb^2/EJ$$

$$= [-1/2 x + 1/6 x^3/b^2]_0^b Fb 1/EJ + 1 (-1) 1 Fb^2/EJ$$

$$= (-1/2 b + 1/6 b) Fb 1/EJ + 1 (-1) 1 Fb^2/EJ = -4/3 Fb^2/EJ$$

$$L_{DE}^{x_0} = \int_0^b (-1/2 + 2x/b - 3/2 x^2/b^2) Fb 1/EJ dx = [-1/2 x + x^2/b - 1/2 x^3/b^2]_0^b Fb 1/EJ$$

$$= (-1/2 b + b - 1/2 b) Fb 1/EJ = 0$$

$$L_{ED}^{x_0} = \int_0^b (x/b - 3/2 x^2/b^2) Fb 1/EJ dx = [1/2 x^2/b - 1/2 x^3/b^2]_0^b Fb 1/EJ$$

$$= (1/2 b - 1/2 b) Fb 1/EJ = 0$$

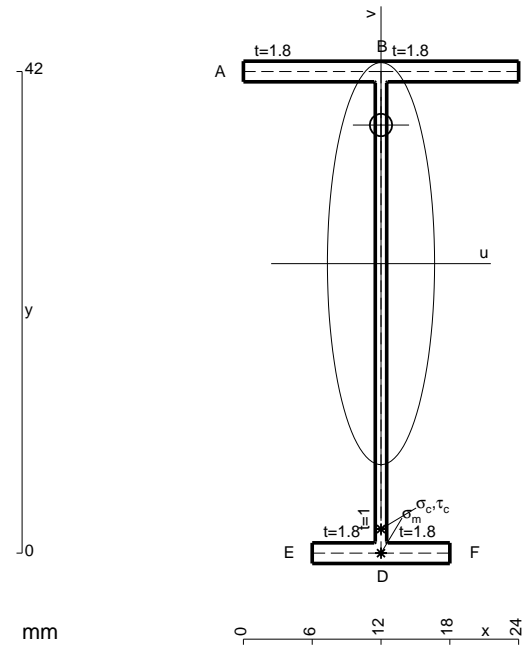

- A = 106.8 mm²
- J_u = 32824. mm⁴
- J_v = 2333. mm⁴
- J_t = 83.98 mm⁴
- y_o = 12.09 mm
- y_g = 25.25 mm
- N = -220. N
- T_y = -550. N
- M_x = -308000. Nmm
- x_m = 12. mm
- v_m = -25.25 mm
- σ_m = N/A-Mv/J_u = -239. N/mm²
- y_c = 3. mm
- u_c = -12. mm
- v_c = -22.25 mm
- σ_c = N/A-Mv/J_u = -239. N/mm²
- τ_c = TS'/tJ_u = 9.138 N/mm²
- τ_g = TS'/tJ_u = 9.138 N/mm²
- t_c = 220. mm
- σ_o = √σ²+3τ² = 239.5 N/mm²

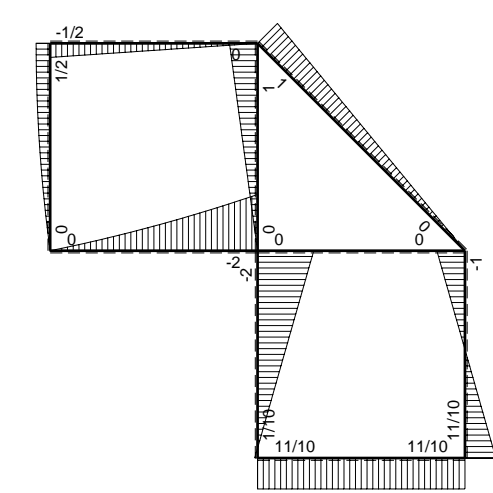
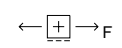
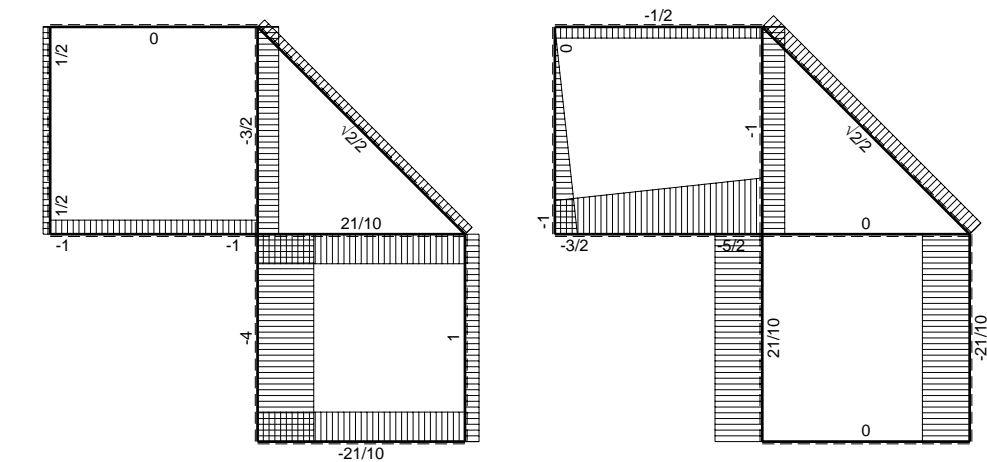
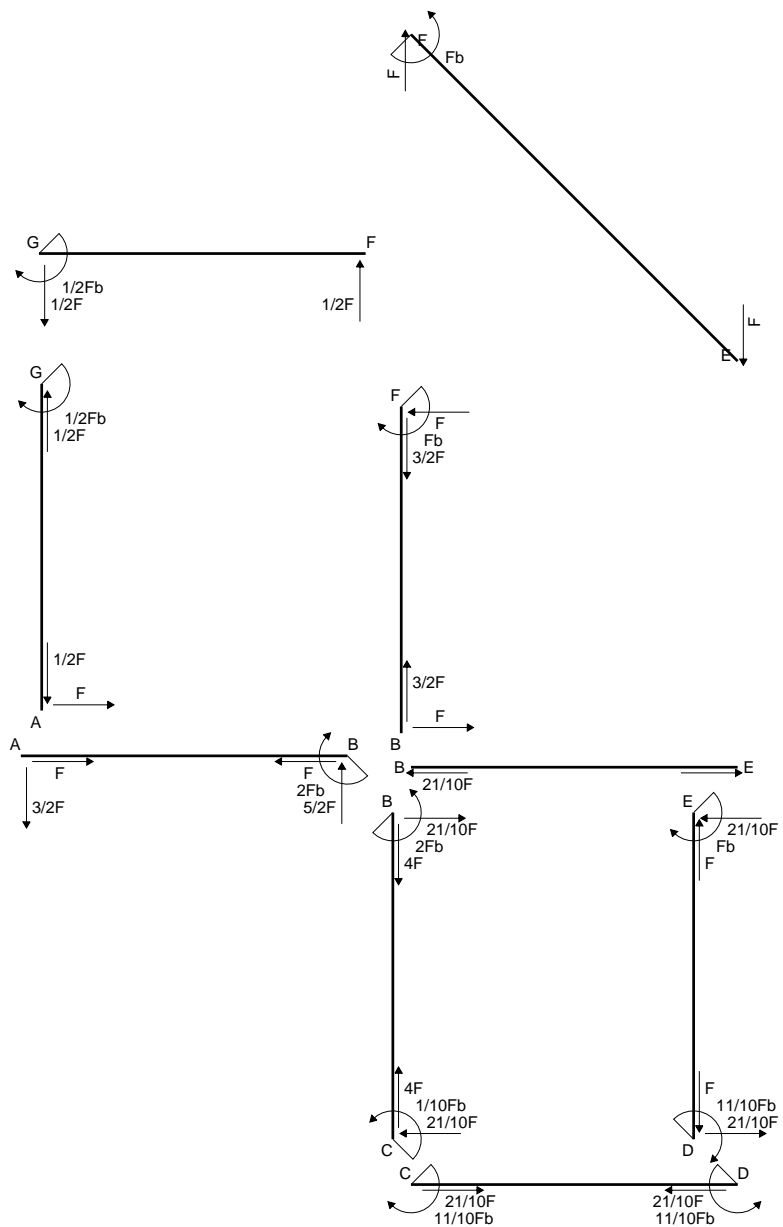

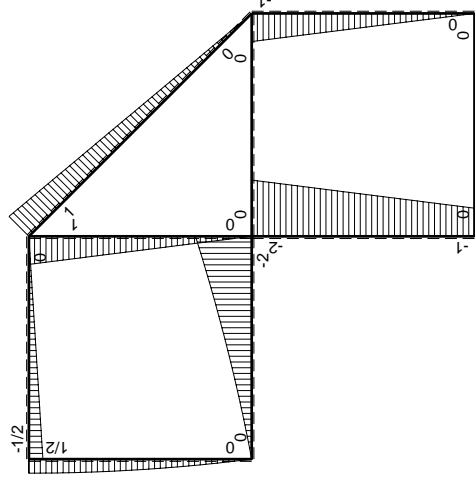
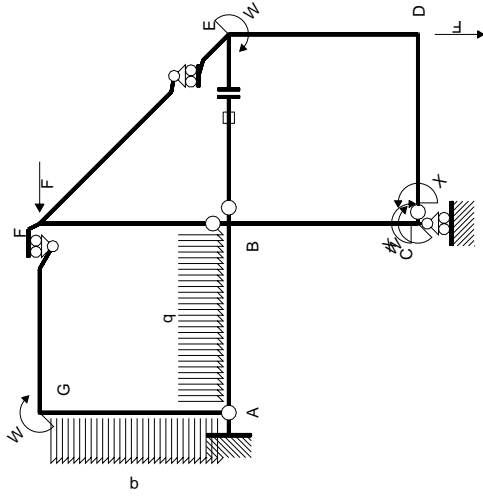

Schema di calcolo iperstatico

M_0 flessione da carichi assegnati

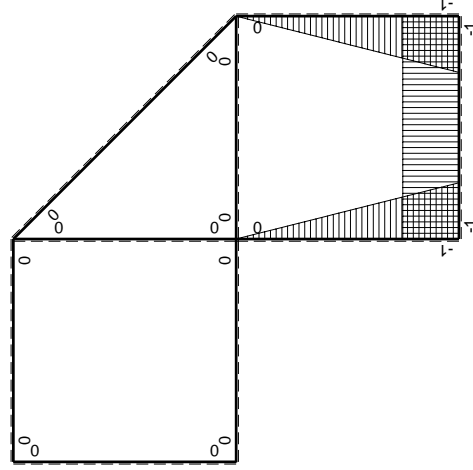

M_x flessione da iperstatica $X=1$

Quadro contribuiti PLV per iperstatica $X=W_{CD}$

→	$M_x(x)$	$M_0(x)$	$M_x M_0$	$M_x M_x$	$\int M_x M_0 / EJ dx$	$\int M_x M_x / EJ dx$
AB b	0	$-3/2Fx - 1/2qx^2$	0	0	0	0
BA b	0	$2Fb - 5/2Fx + 1/2qx^2$	0	0	0	0
BC b	$-x/b$	$-2Fb + Fx$	$2Fx - Fx^2/b$	x^2/b^2	$2/3Fb^2/EJ$	$1/3Xb/EJ$
CB b	$1-x/b$	$Fb + Fx$	$Fb - Fx^2/b$	$1 - 2x/b + x^2/b^2$	0	0
CD b	-1	0	0	1	0	Xb/EJ
DC b	1	0	0	1	0	0
DE b	$-1+x/b$	$-Fx$	$Fx - Fx^2/b$	$1 - 2x/b + x^2/b^2$	$1/6Fb^2/EJ$	$1/3Xb/EJ$
ED b	x/b	$Fb - Fx$	$Fx - Fx^2/b$	x^2/b^2	0	0
EF $\sqrt{2}b$	0	$\sqrt{2}/2Fx$	0	0	0	0
FG b	0	$-1/2Fx$	0	0	0	0
GF b	0	$1/2Fb - 1/2Fx$	0	0	0	0
GA b	0	$1/2Fb - 1/2qx^2$	0	0	0	0
AG b	0	$-Fx + 1/2qx^2$	0	0	0	0
FB b	0	$Fb - Fx$	0	0	0	0
BF b	0	$-Fx$	0	0	0	0
BE b	0	0	0	0	0	0
EB b	0	0	0	0	0	0
BE	elongazione asta $N_{1, BE}^{\epsilon_{BE}} L_{BE}$				Fb^2/EJ	
	totali				$11/6Fb^2/EJ$	$5/3Xb/EJ$
	iperstatica $X=W_{CD}$					$-11/10Fb$

Sviluppi di calcolo iperstatica

$$L_{BC}^{xx} = \int_0^b (x^2/b^2) 1/EJ dx = [1/3 x^3/b^2]_0^b 1/EJ$$

$$= (1/3 b) 1/EJ = 1/3 b/EJ$$

$$L_{CB}^{xx} = \int_0^b (1 - 2x/b + x^2/b^2) 1/EJ dx = [x - x^2/b + 1/3 x^3/b^2]_0^b 1/EJ$$

$$= (b - b + 1/3 b) 1/EJ = 1/3 b/EJ$$

$$L_{CD}^{xx} = \int_0^b (1) 1/EJ dx = [x]_0^b 1/EJ$$

$$= (b) 1/EJ = b/EJ$$

$$L_{DC}^{xx} = \int_0^b (1) 1/EJ dx = [x]_0^b 1/EJ$$

$$= (b) 1/EJ = b/EJ$$

$$L_{DE}^{xx} = \int_0^b (1 - 2x/b + x^2/b^2) 1/EJ dx = [x - x^2/b + 1/3 x^3/b^2]_0^b 1/EJ$$

$$= (b - b + 1/3 b) 1/EJ = 1/3 b/EJ$$

$$L_{ED}^{xx} = \int_0^b (x^2/b^2) 1/EJ dx = [1/3 x^3/b^2]_0^b 1/EJ$$

$$= (1/3 b) 1/EJ = 1/3 b/EJ$$

$$L_{BC}^{xo} = \int_0^b (2x/b - x^2/b^2) Fb 1/EJ dx = [x^2/b - 1/3 x^3/b^2]_0^b Fb 1/EJ$$

$$= (b - 1/3 b) Fb 1/EJ = 2/3 Fb^2/EJ$$

$$L_{CB}^{xo} = \int_0^b (1 - x^2/b^2) Fb 1/EJ dx = [x - 1/3 x^3/b^2]_0^b Fb 1/EJ$$

$$= (b - 1/3 b) Fb 1/EJ = 2/3 Fb^2/EJ$$

$$L_{DE}^{xo} = \int_0^b (x/b - x^2/b^2) Fb 1/EJ dx = [1/2 x^2/b - 1/3 x^3/b^2]_0^b Fb 1/EJ$$

$$= (1/2 b - 1/3 b) Fb 1/EJ = 1/6 Fb^2/EJ$$

$$L_{ED}^{xo} = \int_0^b (x/b - x^2/b^2) Fb 1/EJ dx = [1/2 x^2/b - 1/3 x^3/b^2]_0^b Fb 1/EJ$$

$$= (1/2 b - 1/3 b) Fb 1/EJ = 1/6 Fb^2/EJ$$

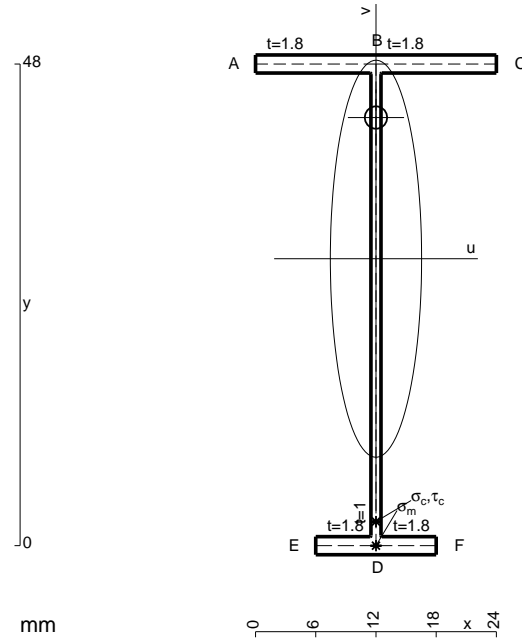

$A = 112.8 \text{ mm}^2$
 $J_u = 44158. \text{ mm}^4$
 $J_v = 2333. \text{ mm}^4$
 $J_t = 85.98 \text{ mm}^4$
 $y_o = 14.07 \text{ mm}$
 $y_g = 28.6 \text{ mm}$
 $N = -220. \text{ N}$
 $T_y = -550. \text{ N}$
 $M_x = -294800. \text{ Nmm}$
 $x_m = 12. \text{ mm}$
 $v_m = -28.6 \text{ mm}$
 $\sigma_m = N/A - Mv/J_u = -192.9 \text{ N/mm}^2$
 $y_c = 3. \text{ mm}$
 $u_c = -12. \text{ mm}$
 $v_c = -25.6 \text{ mm}$
 $\sigma_c = N/A - Mv/J_u = -192.9 \text{ N/mm}^2$
 $\tau_c = TS'/tJ_u = 7.693 \text{ N/mm}^2$
 $\tau_g = TS'/tJ_u = 7.693 \text{ N/mm}^2$
 $t_c = 220. \text{ mm}$
 $\sigma_o = \sqrt{\sigma^2 + 3\tau^2} = 193.3 \text{ N/mm}^2$

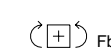
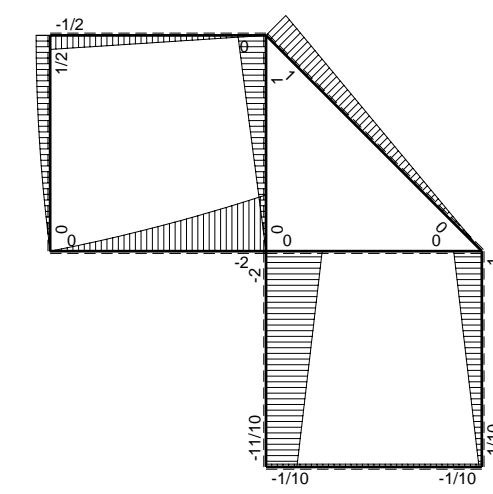
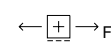
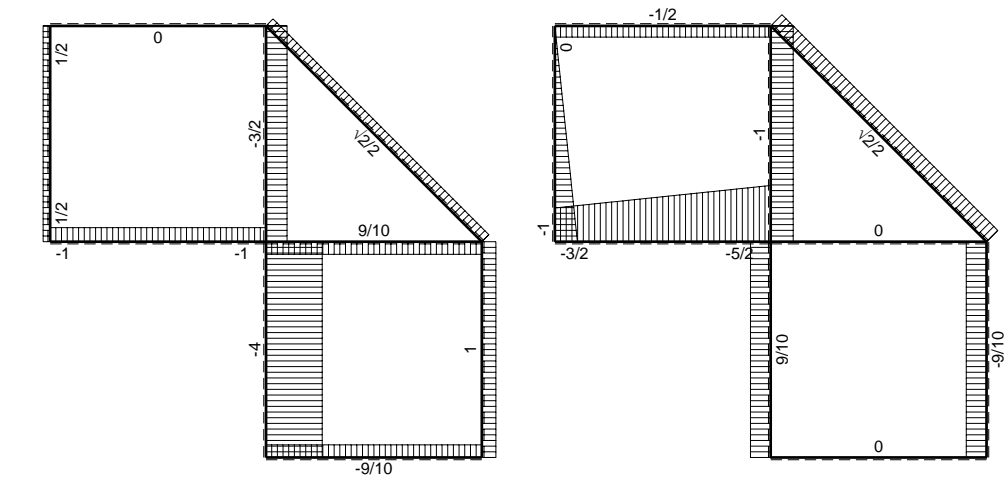
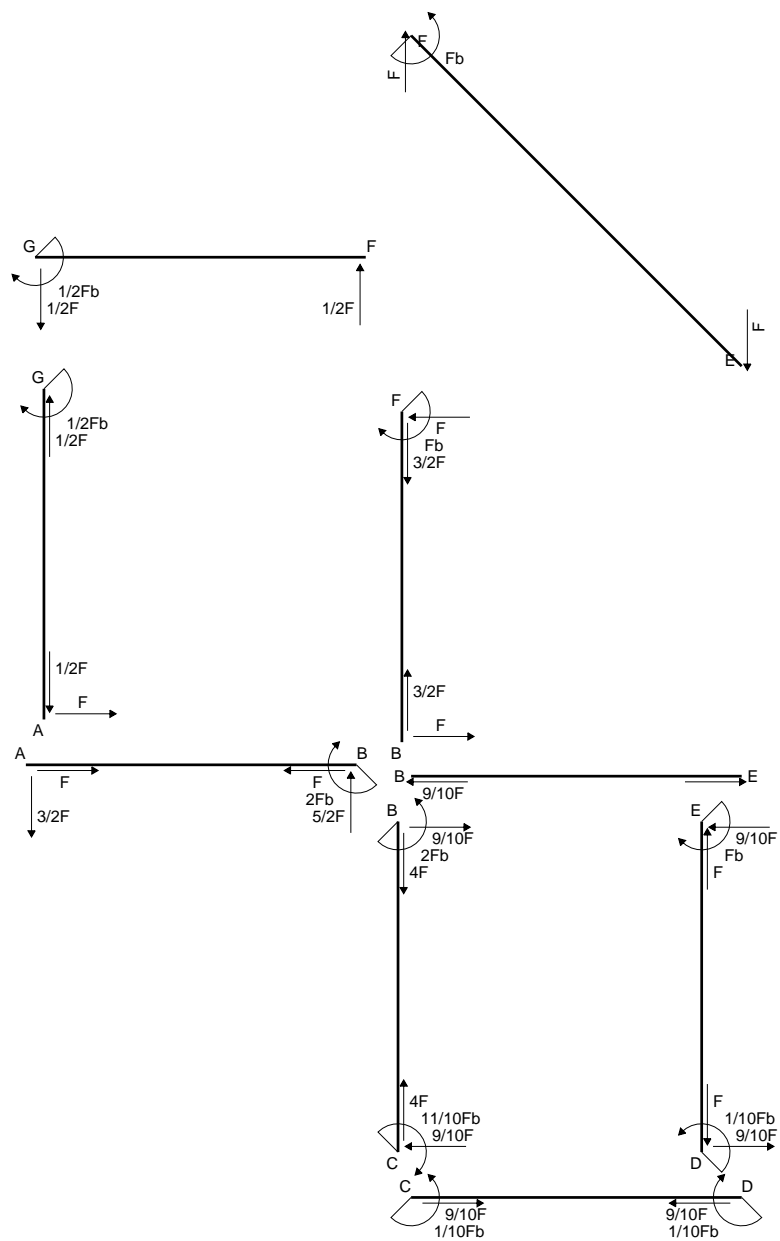

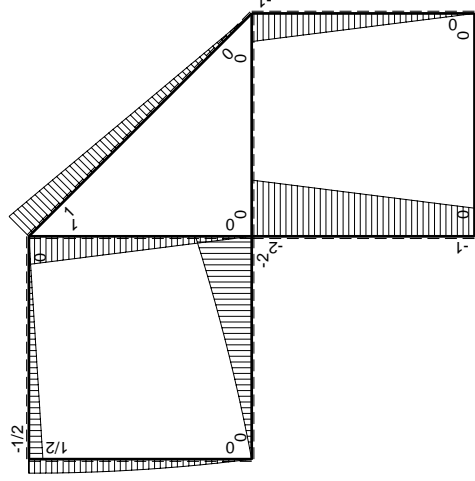
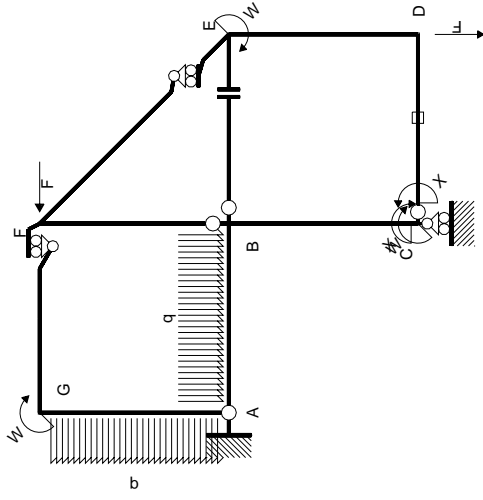

Schema di calcolo iperstatico

M_0 flessione da carichi assegnati

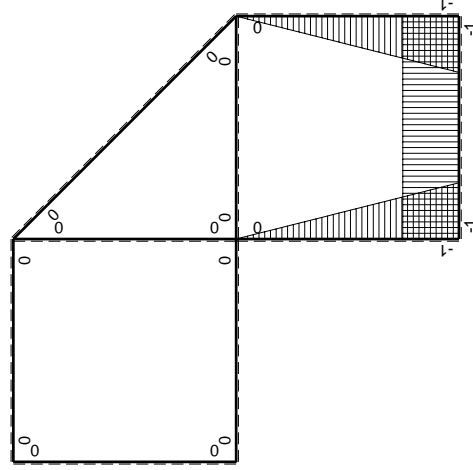

M_x flessione da iperstatica $X=1$

Quadro contribuiti PLV per iperstatica $X=W_{CD}$

\rightarrow	$M_x(x)$	$M_0(x)$	$M_x M_0$	$M_x M_x$	$\int M_x M_0 / EJ dx$	$\int M_x M_x / EJ dx$
AB b	0	$-3/2Fx - 1/2qx^2$	0	0	0	0
BA b	0	$2Fb - 5/2Fx + 1/2qx^2$	0	0	0	0
BC b	$-x/b$	$-2Fb + Fx$	$2Fx - Fx^2/b$	x^2/b^2	$2/3Fb^2/EJ$	$1/3Xb/EJ$
CB b	$1-x/b$	$Fb + Fx$	$Fb - Fx^2/b$	$1 - 2x/b + x^2/b^2$		
CD b	-1	0	0	1	0	Xb/EJ
DC b	1	0	0	1	0	
DE b	$-1+x/b$	$-Fx$	$Fx - Fx^2/b$	$1 - 2x/b + x^2/b^2$	$1/6Fb^2/EJ$	$1/3Xb/EJ$
ED b	x/b	$Fb - Fx$	$Fx - Fx^2/b$	x^2/b^2		
EF $\sqrt{2}b$	0	$\sqrt{2}/2Fx$	0	0	0	0
FG b	0	$-1/2Fx$	0	0	0	0
GF b	0	$1/2Fb - 1/2Fx$	0	0	0	0
GA b	0	$1/2Fb - 1/2qx^2$	0	0	0	0
AG b	0	$-Fx + 1/2qx^2$	0	0	0	0
FB b	0	$Fb - Fx$	0	0	0	0
BF b	0	$-Fx$	0	0	0	0
BE b	0	0	0	0	0	0
EB b	0	0	0	0	0	0
CD	elongazione asta $N_{1,cd} \epsilon_{cd} L_{cd}$				$-Fb^2/EJ$	
	totali				$-1/6Fb^2/EJ$	$5/3Xb/EJ$
	iperstatica $X=W_{CD}$				$1/10Fb$	

Sviluppi di calcolo iperstatica

$$L_{BC}^{xx} = \int_0^b (x^2/b^2) 1/EJ dx = [1/3 x^3/b^2]_0^b 1/EJ$$

$$= (1/3 b) 1/EJ = 1/3 b/EJ$$

$$L_{CB}^{xx} = \int_0^b (1 - 2x/b + x^2/b^2) 1/EJ dx = [x - x^2/b + 1/3 x^3/b^2]_0^b 1/EJ$$

$$= (b - b + 1/3 b) 1/EJ = 1/3 b/EJ$$

$$L_{CD}^{xx} = \int_0^b (1) 1/EJ dx = [x]_0^b 1/EJ$$

$$= (b) 1/EJ = b/EJ$$

$$L_{DC}^{xx} = \int_0^b (1) 1/EJ dx = [x]_0^b 1/EJ$$

$$= (b) 1/EJ = b/EJ$$

$$L_{DE}^{xx} = \int_0^b (1 - 2x/b + x^2/b^2) 1/EJ dx = [x - x^2/b + 1/3 x^3/b^2]_0^b 1/EJ$$

$$= (b - b + 1/3 b) 1/EJ = 1/3 b/EJ$$

$$L_{ED}^{xx} = \int_0^b (x^2/b^2) 1/EJ dx = [1/3 x^3/b^2]_0^b 1/EJ$$

$$= (1/3 b) 1/EJ = 1/3 b/EJ$$

$$L_{BC}^{xo} = \int_0^b (2x/b - x^2/b^2) Fb 1/EJ dx = [x^2/b - 1/3 x^3/b^2]_0^b Fb 1/EJ$$

$$= (b - 1/3 b) Fb 1/EJ = 2/3 Fb^2/EJ$$

$$L_{CB}^{xo} = \int_0^b (1 - x^2/b^2) Fb 1/EJ dx = [x - 1/3 x^3/b^2]_0^b Fb 1/EJ$$

$$= (b - 1/3 b) Fb 1/EJ = 2/3 Fb^2/EJ$$

$$L_{DE}^{xo} = \int_0^b (x/b - x^2/b^2) Fb 1/EJ dx = [1/2 x^2/b - 1/3 x^3/b^2]_0^b Fb 1/EJ$$

$$= (1/2 b - 1/3 b) Fb 1/EJ = 1/6 Fb^2/EJ$$

$$L_{ED}^{xo} = \int_0^b (x/b - x^2/b^2) Fb 1/EJ dx = [1/2 x^2/b - 1/3 x^3/b^2]_0^b Fb 1/EJ$$

$$= (1/2 b - 1/3 b) Fb 1/EJ = 1/6 Fb^2/EJ$$

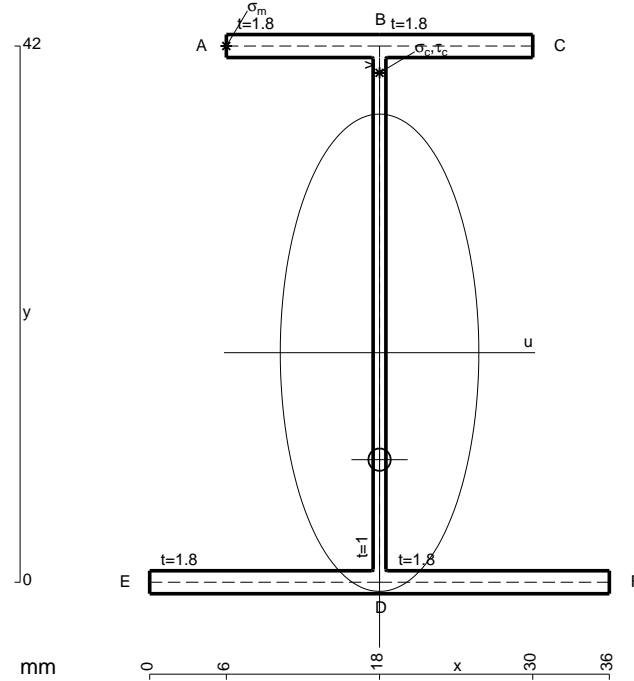

- A = 150. mm²
- J_u = 52430. mm⁴
- J_v = 9072. mm⁴
- J_t = 130.6 mm⁴
- y_o = -8.376 mm
- y_g = 17.98 mm
- N = -360. N
- T_y = -900. N
- M_x = -460800. Nmm
- x_m = 6. mm
- y_m = 42. mm
- u_m = -12. mm
- v_m = 24.02 mm
- σ_m = N/A-Mv/J_u = 208.7 N/mm²
- x_c = 18. mm
- y_c = 42. mm
- v_c = 24.02 mm
- σ_c = N/A-Mv/J_u = 208.7 N/mm²
- τ_c = TS_y/tJ_u = 17.82 N/mm²
- τ_g = TS_y/tJ_u = 17.82 N/mm²
- t_c = 360. mm
- σ_o = √σ²+3τ² = 211. N/mm²

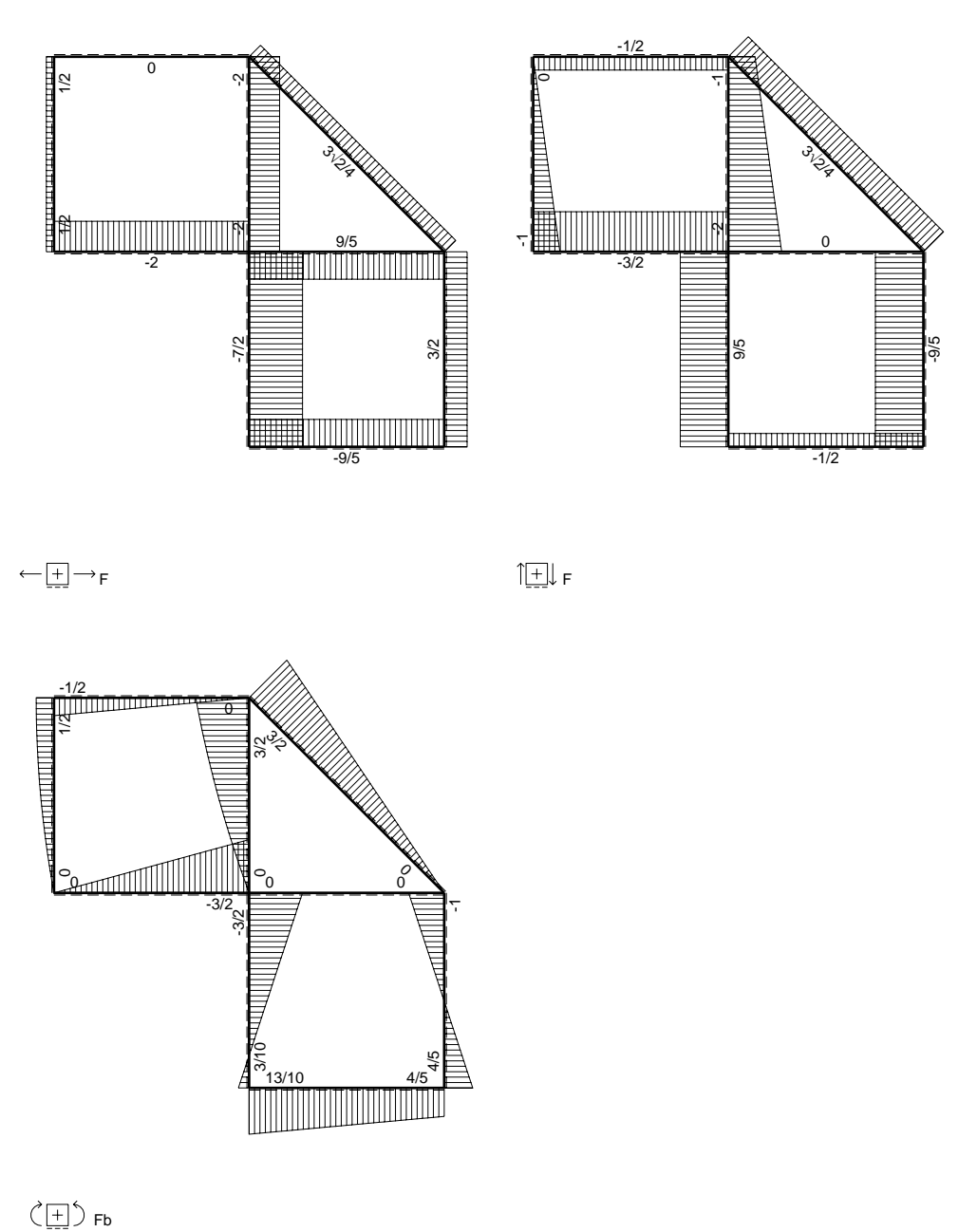
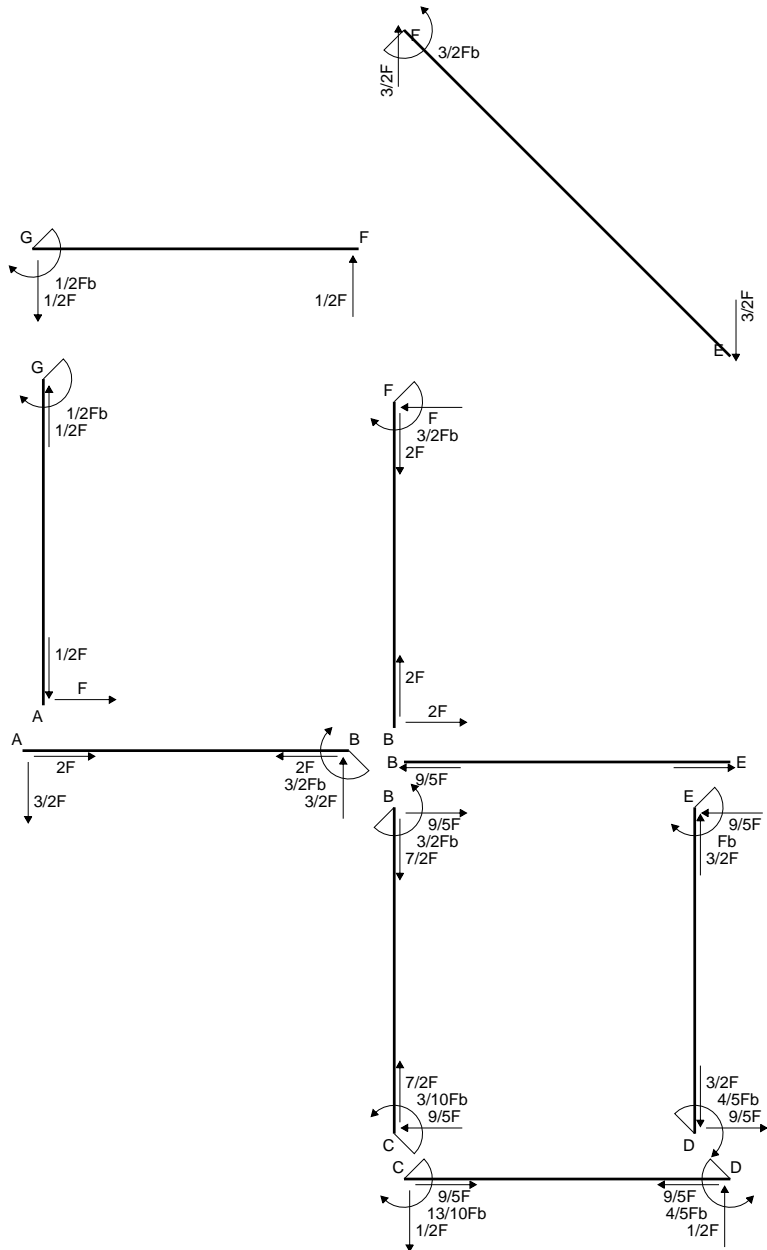

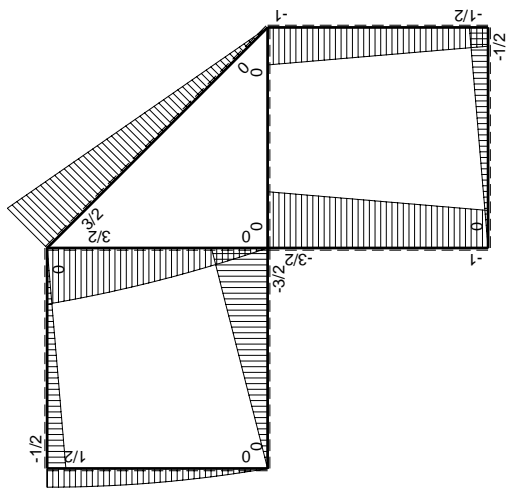
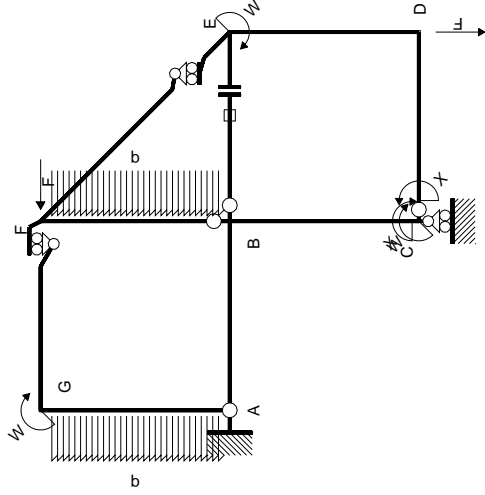

Schema di calcolo iperstatico

M_0 flessione da carichi assegnati

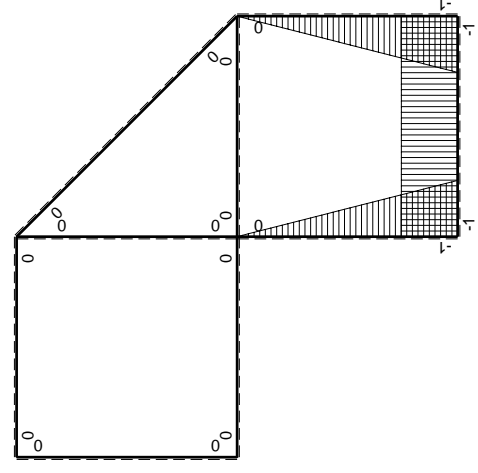

M_x flessione da iperstatica $X=1$

Quadro contribuiti PLV per iperstatica $X=W_{cd}$

\rightarrow	$M_x(x)$	$M_0(x)$	$M_x M_0$	$M_x M_x$	$\int M_x M_0 / E J dx$	$\int M_x M_x / E J dx$
AB b	0	$-3/2Fx$	0	0	0	0
BA b	0	$3/2Fb-3/2Fx$	0	0	0	0
BC b	$-x/b$	$-3/2Fb+1/2Fx$	$3/2Fx-1/2Fx^2/b$	x^2/b^2	$7/12Fb^2/EJ$	$1/3Xb/EJ$
CB b	$1-x/b$	$Fb+1/2Fx$	$Fb-1/2Fx-1/2Fx^2/b$	$1-2x/b+x^2/b^2$		
CD b	-1	$-1/2Fx$	$1/2Fx$	1	$1/4Fb^2/EJ$	Xb/EJ
DC b	1	$1/2Fb-1/2Fx$	$1/2Fb-1/2Fx$	1		
DE b	$-1+x/b$	$-1/2Fb-1/2Fx$	$1/2Fb-1/2Fx^2/b$	$1-2x/b+x^2/b^2$	$1/3Fb^2/EJ$	$1/3Xb/EJ$
ED b	x/b	$Fb-1/2Fx$	$Fx-1/2Fx^2/b$	x^2/b^2		
EF $\sqrt{2}b$	0	$3\sqrt{2}/4Fx$	0	0	0	0
FG b	0	$-1/2Fx$	0	0	0	0
GF b	0	$1/2Fb-1/2Fx$	0	0	0	0
GA b	0	$1/2Fb-1/2qx^2$	0	0	0	0
AG b	0	$-Fx+1/2qx^2$	0	0	0	0
FB b	0	$3/2Fb-Fx-1/2qx^2$	0	0	0	0
BF b	0	$-2Fx+1/2qx^2$	0	0	0	0
BE b	0	0	0	0	0	0
EB b	0	0	0	0	0	0
BE	elongazione asta $N_{1, BE}^{\epsilon_{BE}} L_{BE}$				Fb^2/EJ	
	totali				$13/6Fb^2/EJ$	$5/3Xb/EJ$
	iperstatica $X=W_{cd}$				$-13/10Fb$	

Sviluppi di calcolo iperstatica

$$L_{BC}^{xx} = \int_0^b (x^2/b^2) 1/EJ dx = [1/3 x^3/b^2]_0^b 1/EJ$$

$$= (1/3 b) 1/EJ = 1/3 b/EJ$$

$$L_{CB}^{xx} = \int_0^b (1 - 2x/b + x^2/b^2) 1/EJ dx = [x - x^2/b + 1/3 x^3/b^2]_0^b 1/EJ$$

$$= (b - b + 1/3 b) 1/EJ = 1/3 b/EJ$$

$$L_{CD}^{xx} = \int_0^b (1) 1/EJ dx = [x]_0^b 1/EJ$$

$$= (b) 1/EJ = b/EJ$$

$$L_{DC}^{xx} = \int_0^b (1) 1/EJ dx = [x]_0^b 1/EJ$$

$$= (b) 1/EJ = b/EJ$$

$$L_{DE}^{xx} = \int_0^b (1 - 2x/b + x^2/b^2) 1/EJ dx = [x - x^2/b + 1/3 x^3/b^2]_0^b 1/EJ$$

$$= (b - b + 1/3 b) 1/EJ = 1/3 b/EJ$$

$$L_{ED}^{xx} = \int_0^b (x^2/b^2) 1/EJ dx = [1/3 x^3/b^2]_0^b 1/EJ$$

$$= (1/3 b) 1/EJ = 1/3 b/EJ$$

$$L_{BC}^{xo} = \int_0^b (3/2 x/b - 1/2 x^2/b^2) Fb 1/EJ dx = [3/4 x^2/b - 1/6 x^3/b^2]_0^b Fb 1/EJ$$

$$= (3/4 b - 1/6 b) Fb 1/EJ = 7/12 Fb^2/EJ$$

$$L_{CB}^{xo} = \int_0^b (1 - 1/2 x/b - 1/2 x^2/b^2) Fb 1/EJ dx = [x - 1/4 x^2/b - 1/6 x^3/b^2]_0^b Fb 1/EJ$$

$$= (b - 1/4 b - 1/6 b) Fb 1/EJ = 7/12 Fb^2/EJ$$

$$L_{CD}^{xo} = \int_0^b (1/2 x/b) Fb 1/EJ dx = [1/4 x^2/b]_0^b Fb 1/EJ$$

$$= (1/4 b) Fb 1/EJ = 1/4 Fb^2/EJ$$

$$L_{DC}^{xo} = \int_0^b (1/2 - 1/2 x/b) Fb 1/EJ dx = [1/2 x - 1/4 x^2/b]_0^b Fb 1/EJ$$

$$= (1/2 b - 1/4 b) Fb 1/EJ = 1/4 Fb^2/EJ$$

$$L_{DE}^{xo} = \int_0^b (1/2 - 1/2 x^2/b^2) Fb 1/EJ dx = [1/2 x - 1/6 x^3/b^2]_0^b Fb 1/EJ$$

$$= (1/2 b - 1/6 b) Fb 1/EJ = 1/3 Fb^2/EJ$$

$$L_{ED}^{xo} = \int_0^b (x/b - 1/2 x^2/b^2) Fb 1/EJ dx = [1/2 x^2/b - 1/6 x^3/b^2]_0^b Fb 1/EJ$$

$$= (1/2 b - 1/6 b) Fb 1/EJ = 1/3 Fb^2/EJ$$

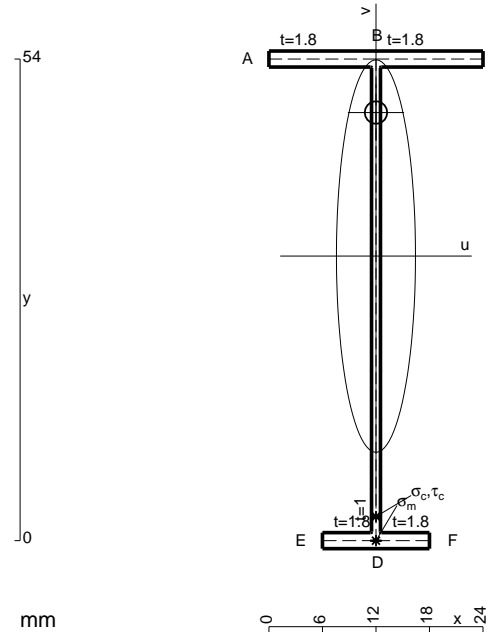

$$A = 118.8 \text{ mm}^2$$

$$J_u = 57498. \text{ mm}^4$$

$$J_v = 2333. \text{ mm}^4$$

$$J_t = 87.98 \text{ mm}^4$$

$$y_o = 16.09 \text{ mm}$$

$$y_g = 31.91 \text{ mm}$$

$$N = -600. \text{ N}$$

$$T_y = -450. \text{ N}$$

$$M_x = -387000. \text{ Nmm}$$

$$x_m = 12. \text{ mm}$$

$$v_m = -31.91 \text{ mm}$$

$$\sigma_m = N/A - Mv/J_u = -219.8 \text{ N/mm}^2$$

$$y_c = 3. \text{ mm}$$

$$u_c = -12. \text{ mm}$$

$$v_c = -28.91 \text{ mm}$$

$$\sigma_c = N/A - Mv/J_u = -219.8 \text{ N/mm}^2$$

$$\tau_c = TS'/tJ_u = 5.394 \text{ N/mm}^2$$

$$\tau_g = TS'/tJ_u = 5.394 \text{ N/mm}^2$$

$$t_c = 300. \text{ mm}$$

$$\sigma_o = \sqrt{\sigma^2 + 3\tau^2} = 220. \text{ N/mm}^2$$

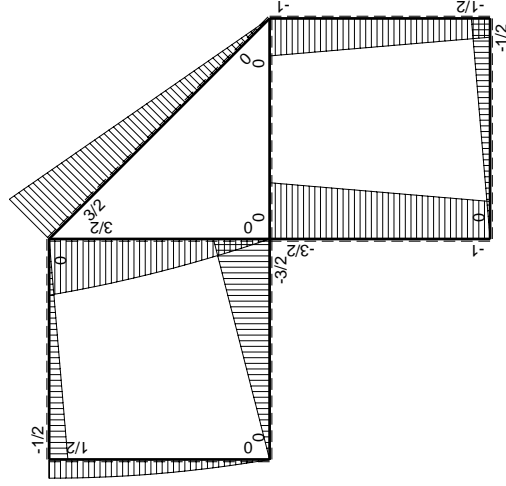
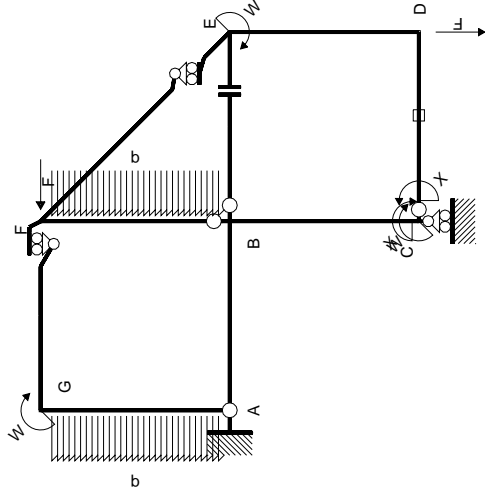

Schema di calcolo iperstatico

M_0 flessione da carichi assegnati

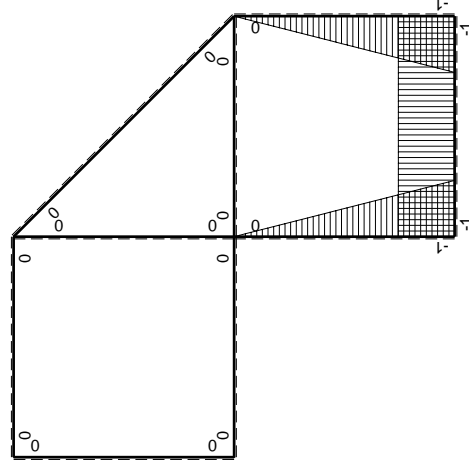

M_x flessione da iperstatica X=1

Quadro contribuiti PLV per iperstatica X=W_{cd}

→	$M_x(x)$	$M_0(x)$	$M_x M_0$	$M_x M_x$	$\int M_x M_0 / E J dx$	$\int M_x M_x / E J dx$
AB b	0	-3/2Fx	0	0	0	0
BA b	0	3/2Fb-3/2Fx	0	0	0	0
BC b	-x/b	-3/2Fb+1/2Fx	3/2Fx-1/2Fx ² /b	x ² /b ²	7/12Fb ² /EJ	1/3Xb/EJ
CB b	1-x/b	Fb+1/2Fx	Fb-1/2Fx-1/2Fx ² /b	1-2x/b+x ² /b ²	1/4Fb ² /EJ	Xb/EJ
CD b	-1	-1/2Fx	1/2Fx	1	1/4Fb ² /EJ	Xb/EJ
DC b	1	1/2Fb-1/2Fx	1/2Fb-1/2Fx	1	1/4Fb ² /EJ	Xb/EJ
DE b	-1+x/b	-1/2Fb-1/2Fx	1/2Fb-1/2Fx ² /b	1-2x/b+x ² /b ²	1/3Fb ² /EJ	1/3Xb/EJ
ED b	x/b	Fb-1/2Fx	Fx-1/2Fx ² /b	x ² /b ²	1/3Fb ² /EJ	1/3Xb/EJ
EF √2b	0	3√2/4Fx	0	0	0	0
FG b	0	-1/2Fx	0	0	0	0
GF b	0	1/2Fb-1/2Fx	0	0	0	0
GA b	0	1/2Fb-1/2qx ²	0	0	0	0
AG b	0	-Fx+1/2qx ²	0	0	0	0
FB b	0	3/2Fb-Fx-1/2qx ²	0	0	0	0
BF b	0	-2Fx+1/2qx ²	0	0	0	0
BE b	0	0	0	0	0	0
EB b	0	0	0	0	0	0
CD	elongazione asta $N_{1,cd} \epsilon_{cd} L_{cd}$				-Fb ² /EJ	
	totali				1/6Fb ² /EJ	5/3Xb/EJ
	iperstatica X=W _{cd}				-1/10Fb	

Sviluppi di calcolo iperstatica

$$L_{BC}^{xx} = \int_0^b (x^2/b^2) 1/EJ dx = [1/3 x^3/b^2]_0^b 1/EJ$$

$$= (1/3 b) 1/EJ = 1/3 b/EJ$$

$$L_{CB}^{xx} = \int_0^b (1 - 2x/b + x^2/b^2) 1/EJ dx = [x - x^2/b + 1/3 x^3/b^2]_0^b 1/EJ$$

$$= (b - b + 1/3 b) 1/EJ = 1/3 b/EJ$$

$$L_{CD}^{xx} = \int_0^b (1) 1/EJ dx = [x]_0^b 1/EJ$$

$$= (b) 1/EJ = b/EJ$$

$$L_{DC}^{xx} = \int_0^b (1) 1/EJ dx = [x]_0^b 1/EJ$$

$$= (b) 1/EJ = b/EJ$$

$$L_{DE}^{xx} = \int_0^b (1 - 2x/b + x^2/b^2) 1/EJ dx = [x - x^2/b + 1/3 x^3/b^2]_0^b 1/EJ$$

$$= (b - b + 1/3 b) 1/EJ = 1/3 b/EJ$$

$$L_{ED}^{xx} = \int_0^b (x^2/b^2) 1/EJ dx = [1/3 x^3/b^2]_0^b 1/EJ$$

$$= (1/3 b) 1/EJ = 1/3 b/EJ$$

$$L_{BC}^{xo} = \int_0^b (3/2 x/b - 1/2 x^2/b^2) Fb 1/EJ dx = [3/4 x^2/b - 1/6 x^3/b^2]_0^b Fb 1/EJ$$

$$= (3/4 b - 1/6 b) Fb 1/EJ = 7/12 Fb^2/EJ$$

$$L_{CB}^{xo} = \int_0^b (1 - 1/2 x/b - 1/2 x^2/b^2) Fb 1/EJ dx = [x - 1/4 x^2/b - 1/6 x^3/b^2]_0^b Fb 1/EJ$$

$$= (b - 1/4 b - 1/6 b) Fb 1/EJ = 7/12 Fb^2/EJ$$

$$L_{CD}^{xo} = \int_0^b (1/2 x/b) Fb 1/EJ dx + 1 (-1) 1 Fb^2/EJ = [1/4 x^2/b]_0^b Fb 1/EJ + 1 (-1) 1 Fb^2/EJ$$

$$= (1/4 b) Fb 1/EJ + 1 (-1) 1 Fb^2/EJ = -3/4 Fb^2/EJ$$

$$L_{DC}^{xo} = \int_0^b (1/2 - 1/2 x/b) Fb 1/EJ dx + 1 (-1) 1 Fb^2/EJ = [1/2 x - 1/4 x^2/b]_0^b Fb 1/EJ + 1 (-1) 1 Fb^2/EJ$$

$$= (1/2 b - 1/4 b) Fb 1/EJ + 1 (-1) 1 Fb^2/EJ = -3/4 Fb^2/EJ$$

$$L_{DE}^{xo} = \int_0^b (1/2 - 1/2 x^2/b^2) Fb 1/EJ dx = [1/2 x - 1/6 x^3/b^2]_0^b Fb 1/EJ$$

$$= (1/2 b - 1/6 b) Fb 1/EJ = 1/3 Fb^2/EJ$$

$$L_{ED}^{xo} = \int_0^b (x/b - 1/2 x^2/b^2) Fb 1/EJ dx = [1/2 x^2/b - 1/6 x^3/b^2]_0^b Fb 1/EJ$$

$$= (1/2 b - 1/6 b) Fb 1/EJ = 1/3 Fb^2/EJ$$

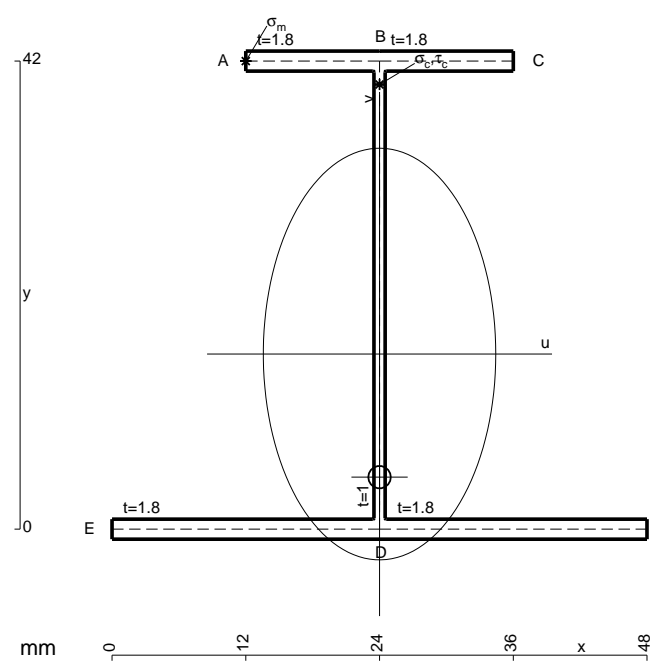

- A = 171.6 mm²
- J_u = 58532. mm⁴
- J_v = 18662. mm⁴
- J_t = 154. mm⁴
- y_o = -11.05 mm
- y_g = 15.71 mm
- N = -960. N
- T_y = -720. N
- M_x = -518400. Nmm
- x_m = 12. mm
- y_m = 42. mm
- u_m = -12. mm
- v_m = 26.29 mm
- σ_m = N/A-Mv/J_u = 227.2 N/mm²
- x_c = 24. mm
- y_c = 42. mm
- v_c = 26.29 mm
- σ_c = N/A-Mv/J_u = 227.2 N/mm²
- τ_c = TS²/tJ_u = 13.97 N/mm²
- τ_g = TS²/tJ_u = 13.97 N/mm²
- t_c = 480. mm
- σ_o = √σ²+3τ² = 228.5 N/mm²

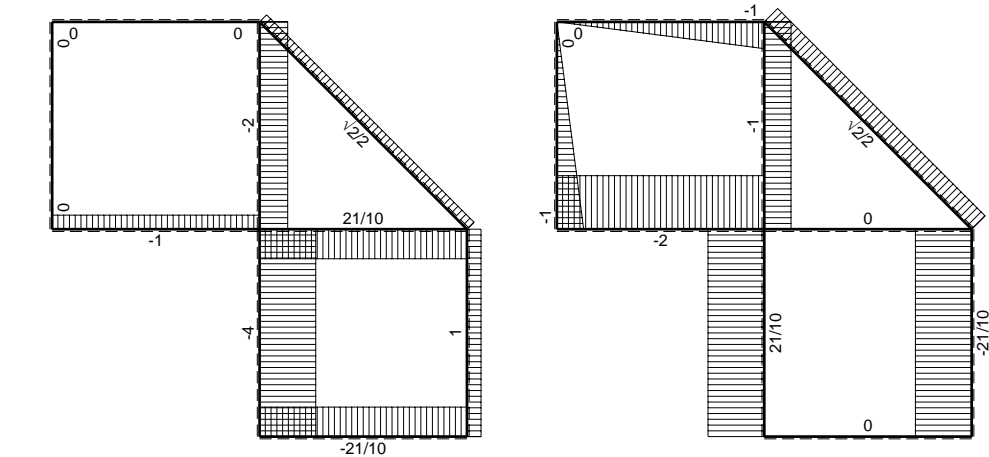
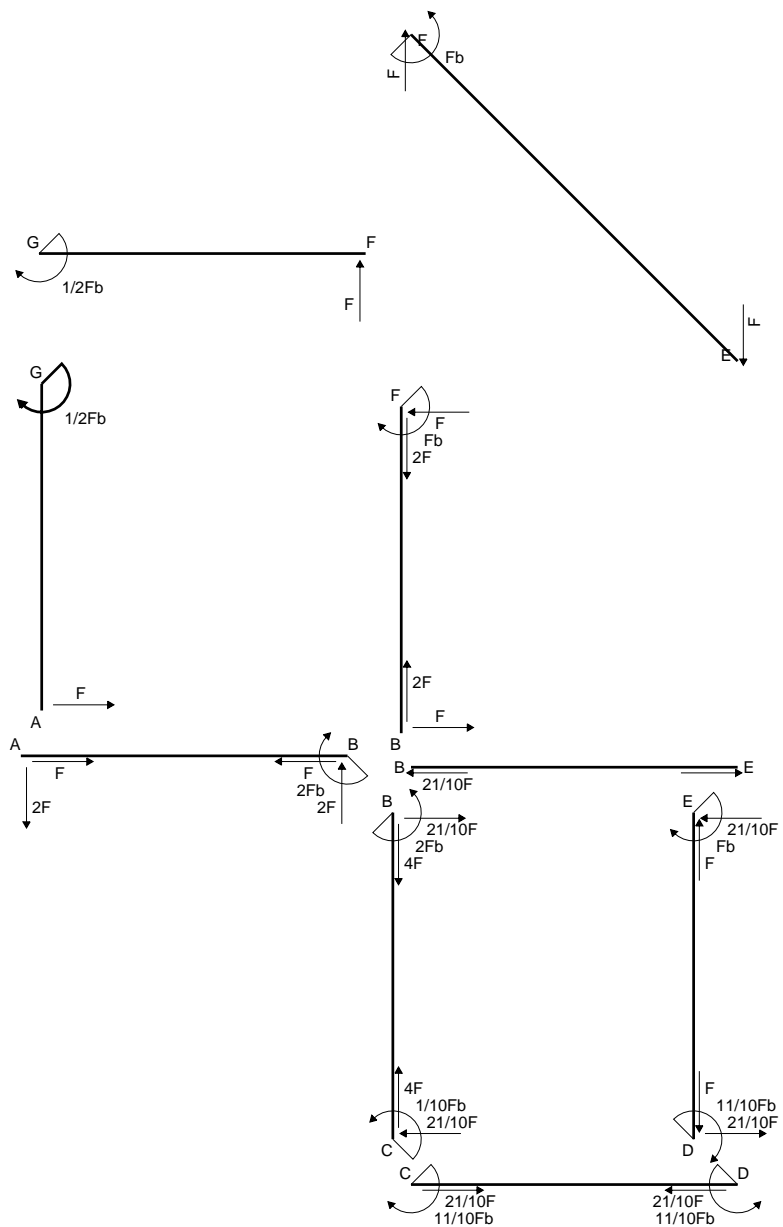

← ⊕ → F

↑ ⊕ ↓ F

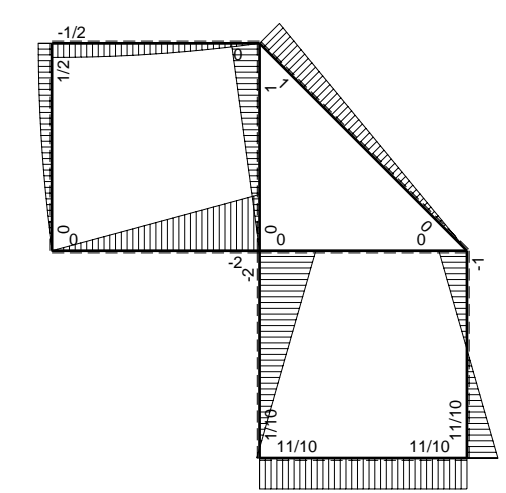

⊕ ↻ F_b

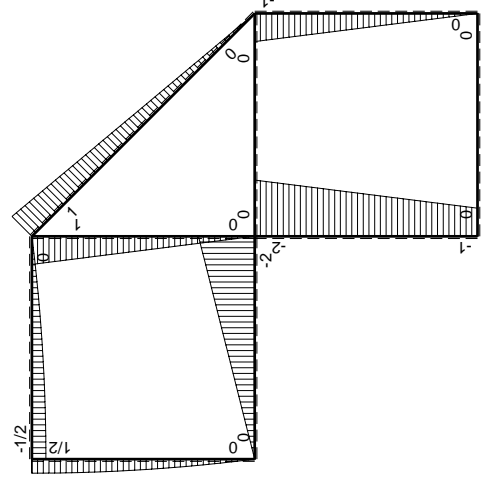
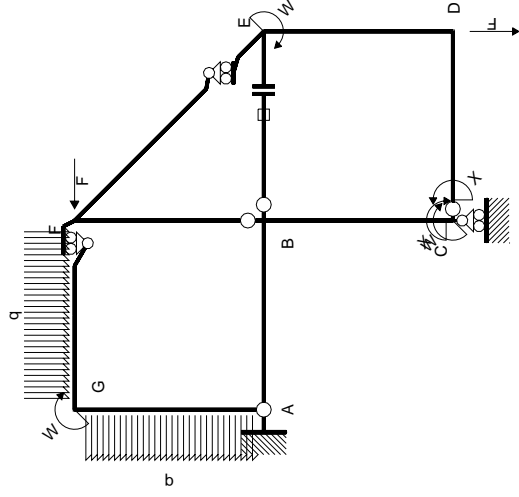

Schema di calcolo iperstatico

M_0 flessione da carichi assegnati

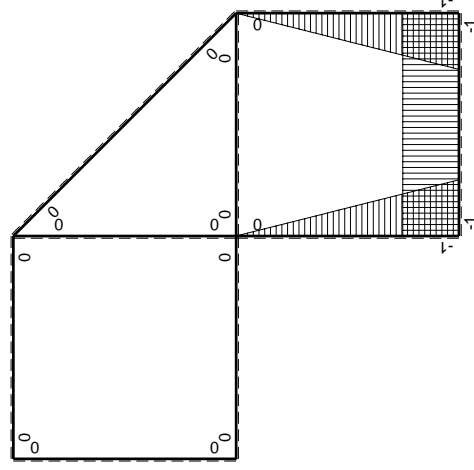

M_x flessione da iperstatica $X=1$

Quadro contribuiti PLV per iperstatica $X=W_{CD}$

\rightarrow	$M_x(x)$	$M_0(x)$	$M_x M_0$	$M_x M_x$	$\int M_x M_0 / E J dx$	$\int X M_x M_x / E J dx$
AB b	0	-2Fx	0	0	0	0
BA b	0	2Fb-2Fx	0	0	0	0
BC b	-x/b	-2Fb+Fx	2Fx-Fx ² /b	x ² /b ²	2/3Fb ² /EJ	1/3Xb/EJ
CB b	1-x/b	Fb+Fx	Fb-Fx ² /b	1-2x/b+x ² /b ²		
CD b	-1	0	0	1	0	Xb/EJ
DC b	1	0	0	1	0	
DE b	-1+x/b	-Fx	Fx-Fx ² /b	1-2x/b+x ² /b ²	1/6Fb ² /EJ	1/3Xb/EJ
ED b	x/b	Fb-Fx	Fx-Fx ² /b	x ² /b ²		
EF $\sqrt{2}b$	0	$\sqrt{2}/2Fx$	0	0	0	0
FG b	0	-Fx+1/2qx ²	0	0	0	0
GF b	0	1/2Fb-1/2qx ²	0	0	0	0
GA b	0	1/2Fb-1/2qx ²	0	0	0	0
AG b	0	-Fx+1/2qx ²	0	0	0	0
FB b	0	Fb-Fx	0	0	0	0
BF b	0	-Fx	0	0	0	0
BE b	0	0	0	0	0	0
EB b	0	0	0	0	0	0
BE	elongazione asta $N_{1, BE} \epsilon_{BE} L_{BE}$				Fb ² /EJ	
	totali				11/6Fb ² /EJ	5/3Xb/EJ
	iperstatica $X=W_{CD}$				-11/10Fb	

Sviluppi di calcolo iperstatica

$$L_{BC}^{xx} = \int_0^b (x^2/b^2) 1/EJ dx = [1/3 x^3/b^2]_0^b 1/EJ$$

$$= (1/3 b) 1/EJ = 1/3 b/EJ$$

$$L_{CB}^{xx} = \int_0^b (1 - 2x/b + x^2/b^2) 1/EJ dx = [x - x^2/b + 1/3 x^3/b^2]_0^b 1/EJ$$

$$= (b - b + 1/3 b) 1/EJ = 1/3 b/EJ$$

$$L_{CD}^{xx} = \int_0^b (1) 1/EJ dx = [x]_0^b 1/EJ$$

$$= (b) 1/EJ = b/EJ$$

$$L_{DC}^{xx} = \int_0^b (1) 1/EJ dx = [x]_0^b 1/EJ$$

$$= (b) 1/EJ = b/EJ$$

$$L_{DE}^{xx} = \int_0^b (1 - 2x/b + x^2/b^2) 1/EJ dx = [x - x^2/b + 1/3 x^3/b^2]_0^b 1/EJ$$

$$= (b - b + 1/3 b) 1/EJ = 1/3 b/EJ$$

$$L_{ED}^{xx} = \int_0^b (x^2/b^2) 1/EJ dx = [1/3 x^3/b^2]_0^b 1/EJ$$

$$= (1/3 b) 1/EJ = 1/3 b/EJ$$

$$L_{BC}^{xo} = \int_0^b (2x/b - x^2/b^2) Fb 1/EJ dx = [x^2/b - 1/3 x^3/b^2]_0^b Fb 1/EJ$$

$$= (b - 1/3 b) Fb 1/EJ = 2/3 Fb^2/EJ$$

$$L_{CB}^{xo} = \int_0^b (1 - x^2/b^2) Fb 1/EJ dx = [x - 1/3 x^3/b^2]_0^b Fb 1/EJ$$

$$= (b - 1/3 b) Fb 1/EJ = 2/3 Fb^2/EJ$$

$$L_{DE}^{xo} = \int_0^b (x/b - x^2/b^2) Fb 1/EJ dx = [1/2 x^2/b - 1/3 x^3/b^2]_0^b Fb 1/EJ$$

$$= (1/2 b - 1/3 b) Fb 1/EJ = 1/6 Fb^2/EJ$$

$$L_{ED}^{xo} = \int_0^b (x/b - x^2/b^2) Fb 1/EJ dx = [1/2 x^2/b - 1/3 x^3/b^2]_0^b Fb 1/EJ$$

$$= (1/2 b - 1/3 b) Fb 1/EJ = 1/6 Fb^2/EJ$$

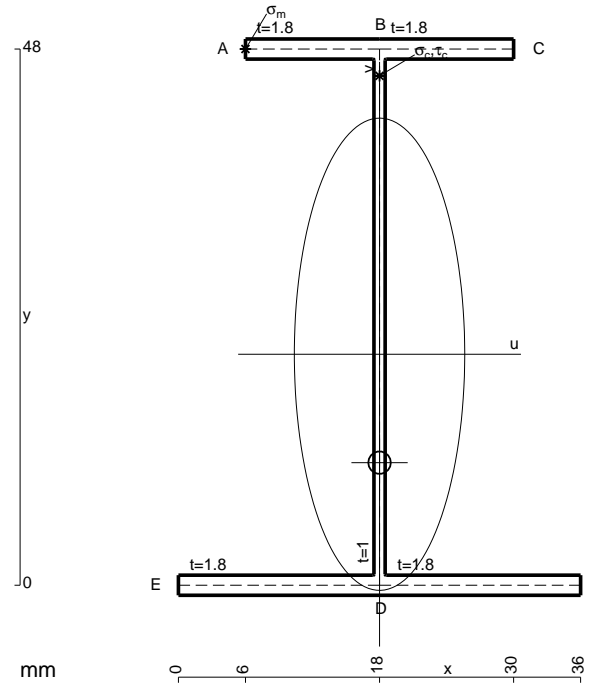

- A = 156. mm²
- J_u = 69701. mm⁴
- J_v = 9072. mm⁴
- J_t = 132.6 mm⁴
- y_o = -9.705 mm
- y_g = 20.68 mm
- N = -360. N
- T_y = -720. N
- M_x = -612000. Nmm
- x_m = 6. mm
- y_m = 48. mm
- u_m = -12. mm
- v_m = 27.32 mm
- σ_m = N/A-Mv/J_u = 237.6 N/mm²
- x_c = 18. mm
- y_c = 48. mm
- v_c = 27.32 mm
- σ_c = N/A-Mv/J_u = 237.6 N/mm²
- τ_c = TS'/tJ_u = 12.19 N/mm²
- τ_g = TS'/tJ_u = 12.19 N/mm²
- t_c = 360. mm
- σ_o = √σ²+3τ² = 238.5 N/mm²

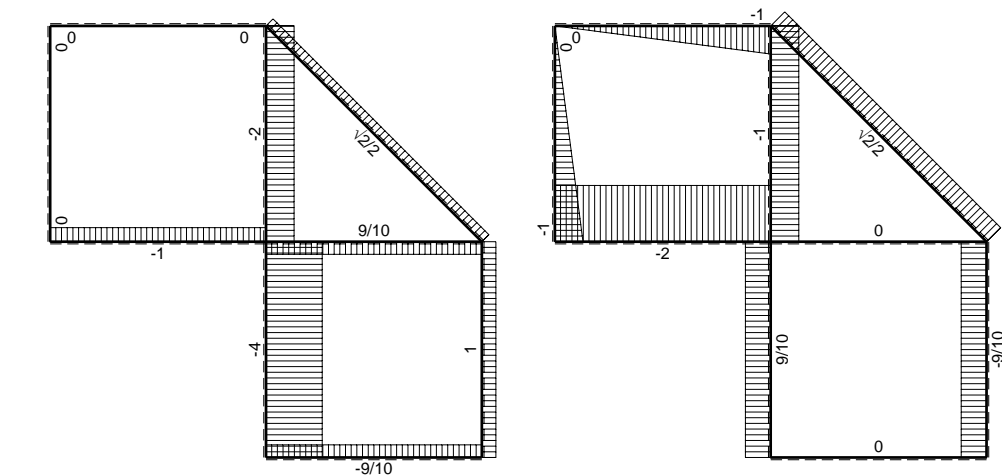
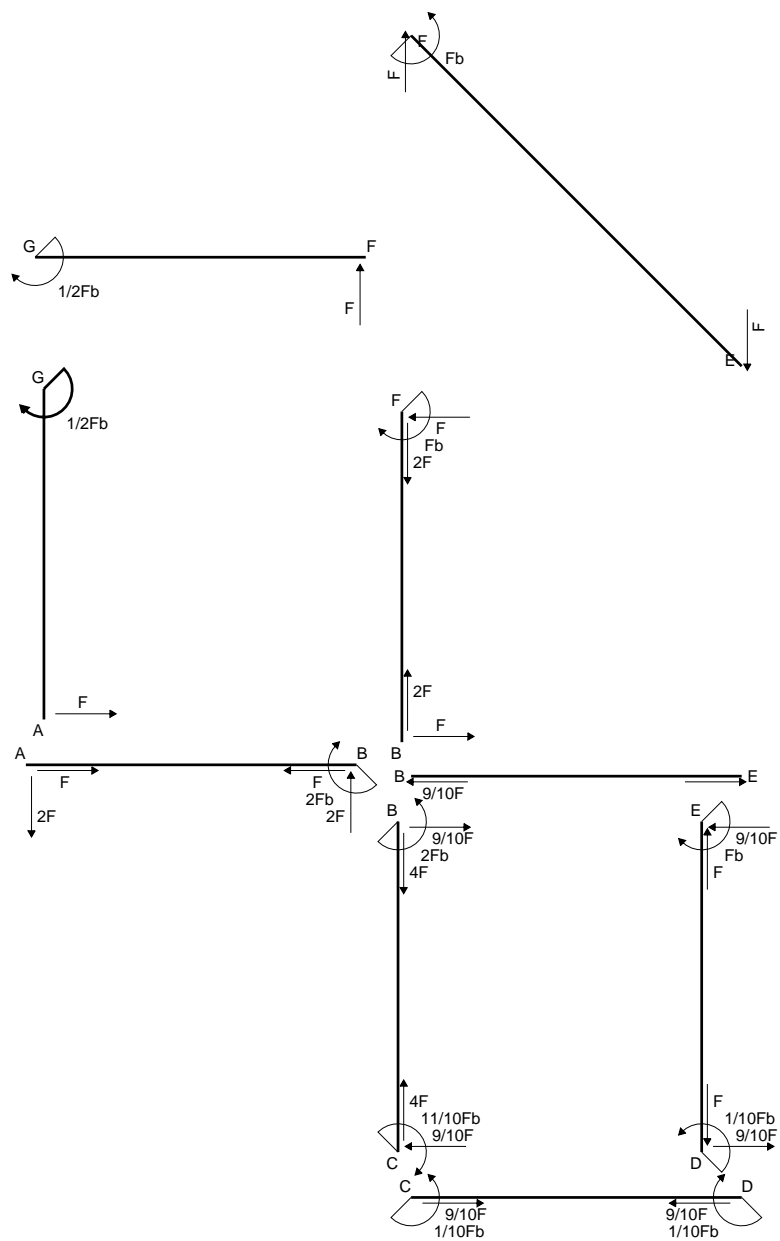

← ⊕ → F

↑ ⊕ ↓ F

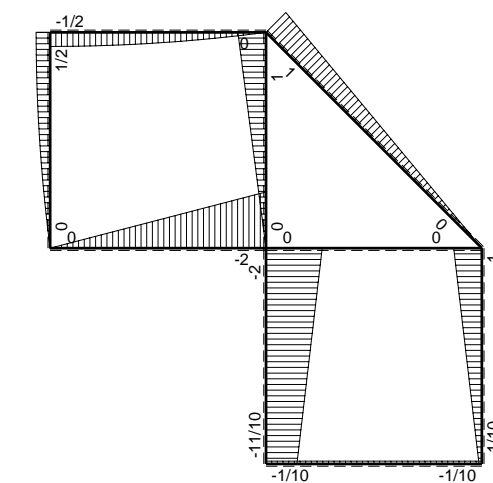

⊕ Fb

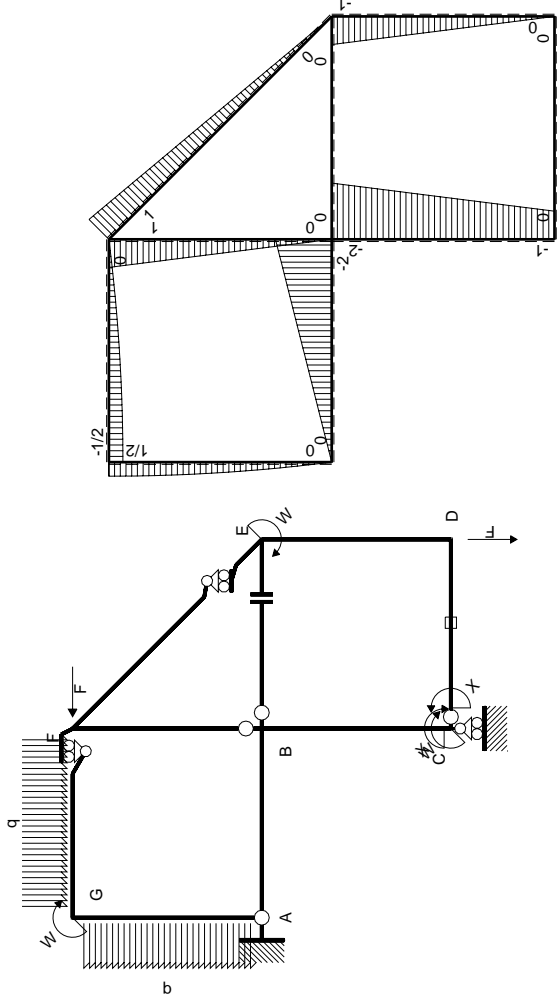

Schema di calcolo iperstatico

M₀ flessione da carichi assegnati

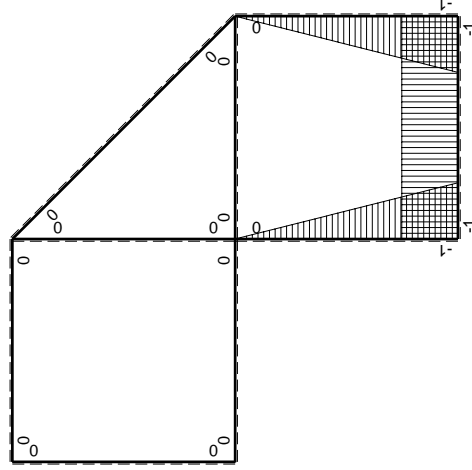

M_x flessione da iperstatica X=1

Quadro contribuiti PLV per iperstatica X=W_{cd}

→	M _x (x)	M ₀ (x)	M _x M ₀	M _x M _x	$\int M_x M_0 / E J dx$	$\int X M_x M_x / E J dx$
AB b	0	-2Fx	0	0	0	0
BA b	0	2Fb-2Fx	0	0	0	0
BC b	-x/b	-2Fb+Fx	2Fx-Fx ² /b	x ² /b ²	2/3Fb ² /EJ	1/3Xb/EJ
CB b	1-x/b	Fb+Fx	Fb-Fx ² /b	1-2x/b+x ² /b ²		
CD b	-1	0	0	1	0	Xb/EJ
DC b	1	0	0	1	0	
DE b	-1+x/b	-Fx	Fx-Fx ² /b	1-2x/b+x ² /b ²	1/6Fb ² /EJ	1/3Xb/EJ
ED b	x/b	Fb-Fx	Fx-Fx ² /b	x ² /b ²		
EF √2b	0	√2/2Fx	0	0	0	0
FG b	0	-Fx+1/2qx ²	0	0	0	0
GF b	0	1/2Fb-1/2qx ²	0	0	0	0
GA b	0	1/2Fb-1/2qx ²	0	0	0	0
AG b	0	-Fx+1/2qx ²	0	0	0	0
FB b	0	Fb-Fx	0	0	0	0
BF b	0	-Fx	0	0	0	0
BE b	0	0	0	0	0	0
EB b	0	0	0	0	0	0
CD	elongazione asta N _{1,cd} ε _{cd} L _{cd}				-Fb ² /EJ	
	totali				-1/6Fb ² /EJ	5/3Xb/EJ
	iperstatica X=W _{cd}				1/10Fb	

Sviluppi di calcolo iperstatica

$$L_{BC}^{xx} = \int_0^b (x^2/b^2) 1/EJ dx = [1/3 x^3/b^2]_0^b 1/EJ$$

$$= (1/3 b) 1/EJ = 1/3 b/EJ$$

$$L_{CB}^{xx} = \int_0^b (1 - 2x/b + x^2/b^2) 1/EJ dx = [x - x^2/b + 1/3 x^3/b^2]_0^b 1/EJ$$

$$= (b - b + 1/3 b) 1/EJ = 1/3 b/EJ$$

$$L_{CD}^{xx} = \int_0^b (1) 1/EJ dx = [x]_0^b 1/EJ$$

$$= (b) 1/EJ = b/EJ$$

$$L_{DC}^{xx} = \int_0^b (1) 1/EJ dx = [x]_0^b 1/EJ$$

$$= (b) 1/EJ = b/EJ$$

$$L_{DE}^{xx} = \int_0^b (1 - 2x/b + x^2/b^2) 1/EJ dx = [x - x^2/b + 1/3 x^3/b^2]_0^b 1/EJ$$

$$= (b - b + 1/3 b) 1/EJ = 1/3 b/EJ$$

$$L_{ED}^{xx} = \int_0^b (x^2/b^2) 1/EJ dx = [1/3 x^3/b^2]_0^b 1/EJ$$

$$= (1/3 b) 1/EJ = 1/3 b/EJ$$

$$L_{BC}^{xo} = \int_0^b (2x/b - x^2/b^2) Fb 1/EJ dx = [x^2/b - 1/3 x^3/b^2]_0^b Fb 1/EJ$$

$$= (b - 1/3 b) Fb 1/EJ = 2/3 Fb^2/EJ$$

$$L_{CB}^{xo} = \int_0^b (1 - x^2/b^2) Fb 1/EJ dx = [x - 1/3 x^3/b^2]_0^b Fb 1/EJ$$

$$= (b - 1/3 b) Fb 1/EJ = 2/3 Fb^2/EJ$$

$$L_{DE}^{xo} = \int_0^b (x/b - x^2/b^2) Fb 1/EJ dx = [1/2 x^2/b - 1/3 x^3/b^2]_0^b Fb 1/EJ$$

$$= (1/2 b - 1/3 b) Fb 1/EJ = 1/6 Fb^2/EJ$$

$$L_{ED}^{xo} = \int_0^b (x/b - x^2/b^2) Fb 1/EJ dx = [1/2 x^2/b - 1/3 x^3/b^2]_0^b Fb 1/EJ$$

$$= (1/2 b - 1/3 b) Fb 1/EJ = 1/6 Fb^2/EJ$$

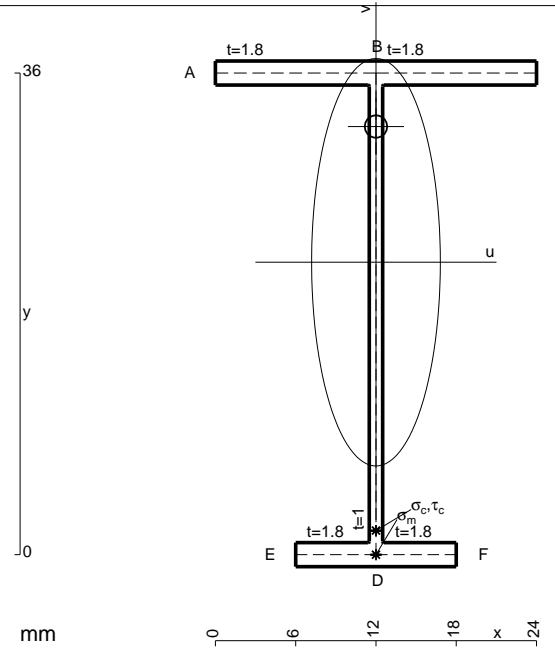

- A = 100.8 mm²
- J_u = 23384. mm⁴
- J_v = 2333. mm⁴
- J_t = 81.98 mm⁴
- y_o = 10.14 mm
- y_g = 21.86 mm
- N = -300. N
- T_y = -600. N
- M_x = -204000. Nmm
- x_m = 12. mm
- v_m = -21.86 mm
- σ_m = N/A - Mv/J_u = -193.7 N/mm²
- y_c = 3. mm
- u_c = -12. mm
- v_c = -18.86 mm
- σ_c = N/A - Mv/J_u = -193.7 N/mm²
- τ_c = TS_t/tJ_u = 12.11 N/mm²
- τ_g = TS_t/tJ_u = 12.11 N/mm²
- t_c = 300. mm
- σ_o = √σ² + 3τ² = 194.8 N/mm²

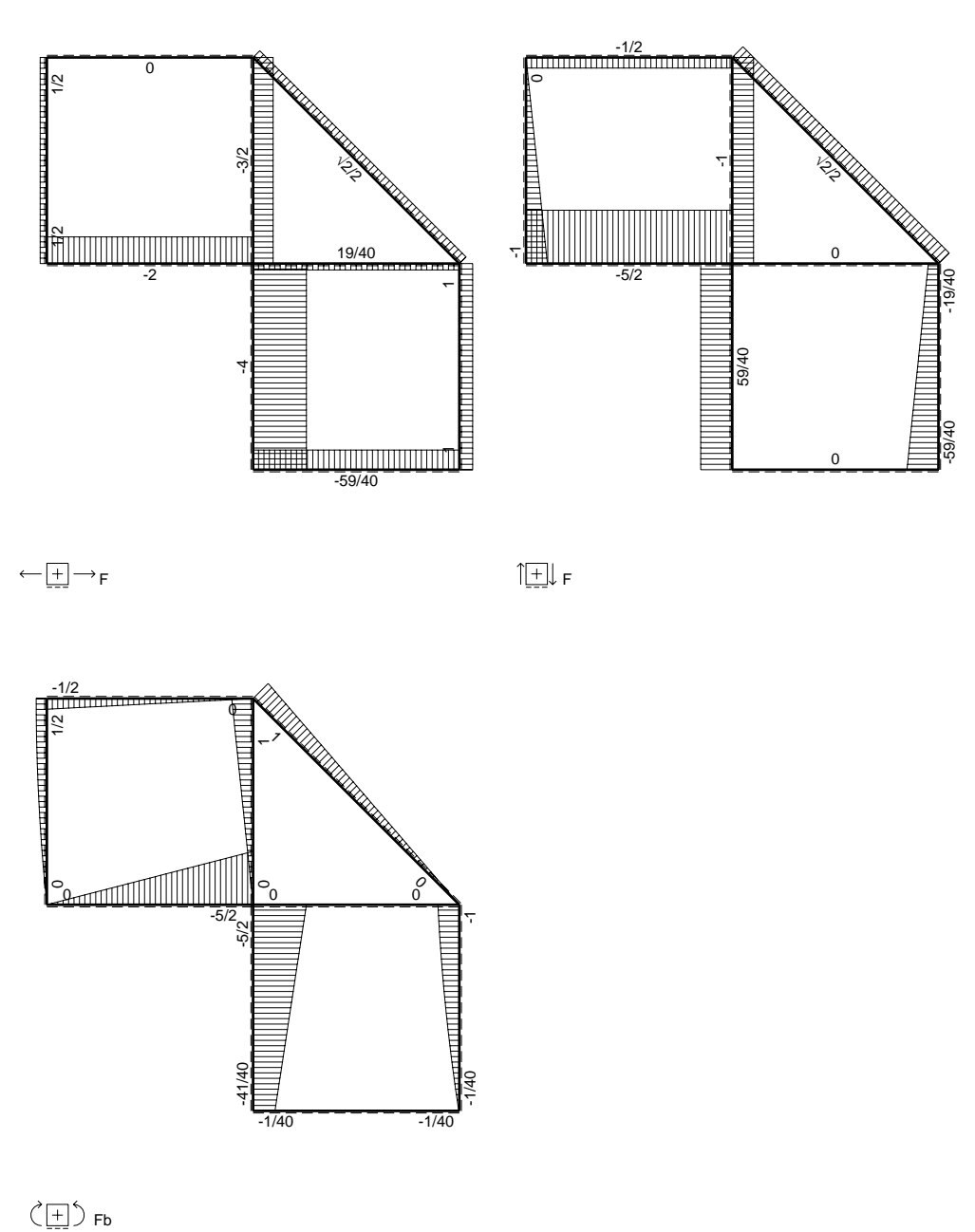
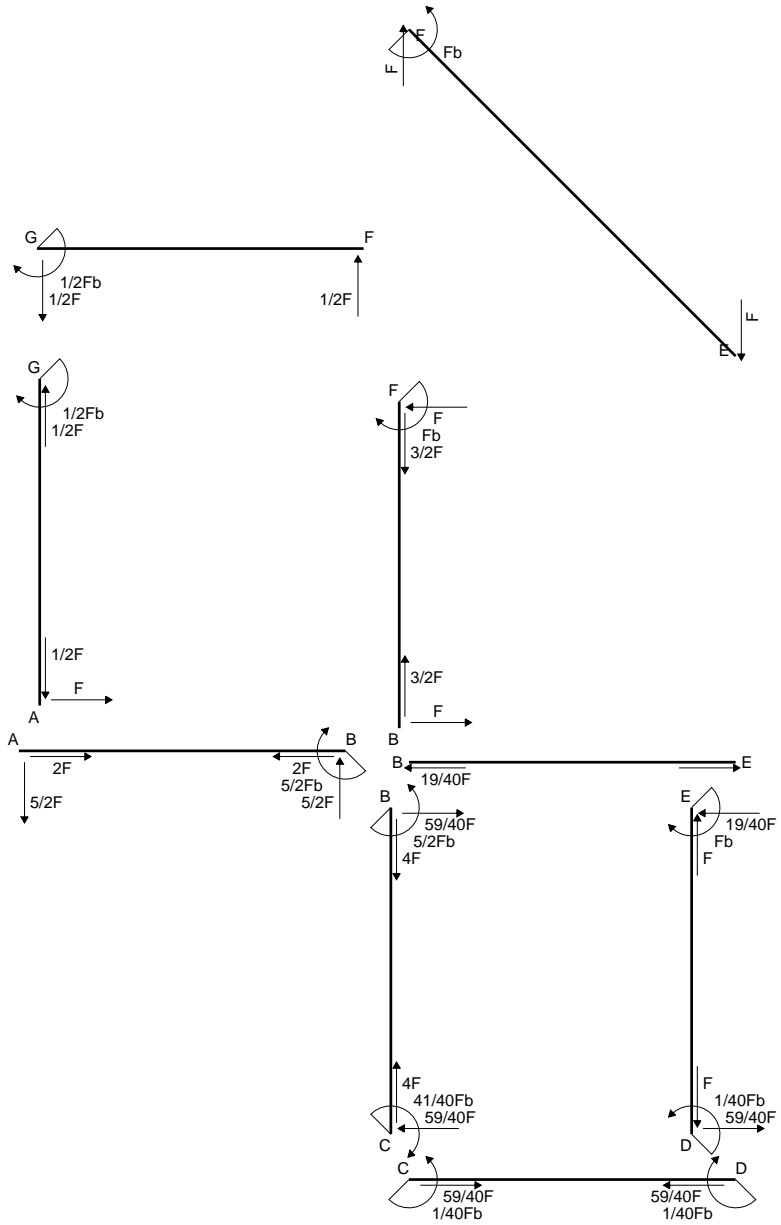

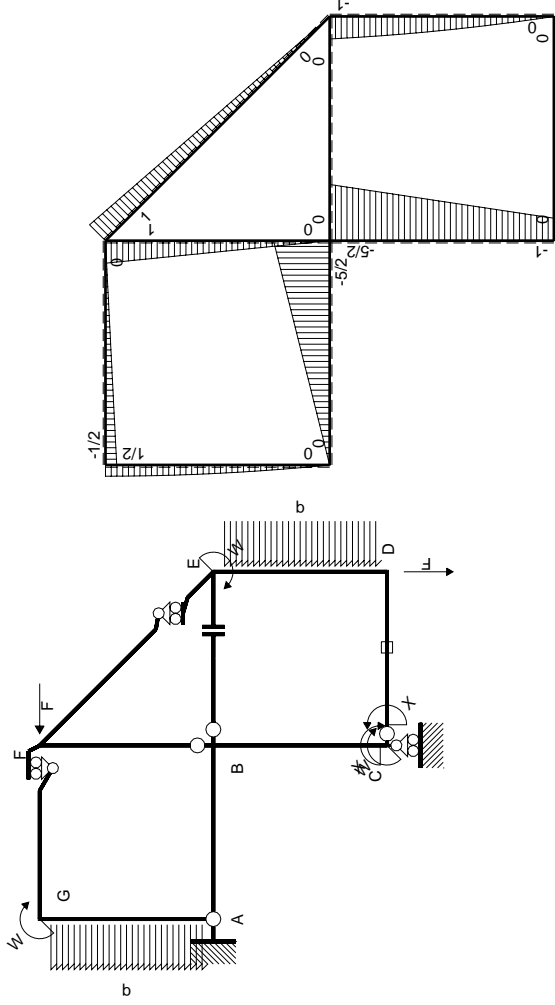

Schema di calcolo iperstatico

M_0 flessione da carichi assegnati

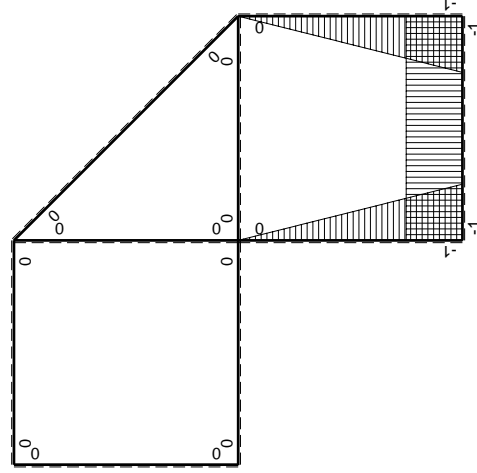

M_x flessione da iperstatica $X=1$

Quadro contribuiti PLV per iperstatica $X=W_{cd}$

\rightarrow	$M_x(x)$	$M_0(x)$	$M_x M_0$	$M_x M_x$	$\int M_x M_0 / EJ dx$	$\int M_x M_x / EJ dx$
AB b	0	$-5/2Fx$	0	0	0	0
BA b	0	$5/2Fb-5/2Fx$	0	0	0	0
BC b	$-x/b$	$-5/2Fb+3/2Fx$	$5/2Fx-3/2Fx^2/b$	x^2/b^2	$3/4Fb^2/EJ$	$1/3Xb/EJ$
CB b	$1-x/b$	$Fb+3/2Fx$	$Fb+1/2Fx-3/2Fx^2/b$	$1-2x/b+x^2/b^2$	0	Xb/EJ
CD b	-1	0	0	1	0	0
DC b	1	0	0	1	0	0
DE b	$-1+x/b$	$-3/2Fx+1/2qx^2$	$3/2Fx-2Fx^2/b+1/2qx^3/b$	$1-2x/b+x^2/b^2$	$5/24Fb^2/EJ$	$1/3Xb/EJ$
ED b	x/b	$Fb-1/2Fx-1/2qx^2$	$Fx-1/2Fx^2/b-1/2qx^3/b$	x^2/b^2	0	0
EF $\sqrt{2}b$	0	$\sqrt{2}/2Fx$	0	0	0	0
FG b	0	$-1/2Fx$	0	0	0	0
GF b	0	$1/2Fb-1/2Fx$	0	0	0	0
GA b	0	$1/2Fb-1/2qx^2$	0	0	0	0
AG b	0	$-Fx+1/2qx^2$	0	0	0	0
FB b	0	$Fb-Fx$	0	0	0	0
BF b	0	$-Fx$	0	0	0	0
BE b	0	0	0	0	0	0
EB b	0	0	0	0	0	0
CD	elongazione asta $N_{1,cd} \epsilon_{cd} L_{cd}$				$-Fb^2/EJ$	
	totali				$-1/24Fb^2/EJ$	$5/3Xb/EJ$
	iperstatica $X=W_{cd}$				$1/40Fb$	

Sviluppi di calcolo iperstatica

$$L_{BC}^{xx} = \int_0^b (x^2/b^2) 1/EJ dx = [1/3 x^3/b^2]_0^b 1/EJ$$

$$= (1/3 b) 1/EJ = 1/3 b/EJ$$

$$L_{CB}^{xx} = \int_0^b (1 - 2x/b + x^2/b^2) 1/EJ dx = [x - x^2/b + 1/3 x^3/b^2]_0^b 1/EJ$$

$$= (b - b + 1/3 b) 1/EJ = 1/3 b/EJ$$

$$L_{CD}^{xx} = \int_0^b (1) 1/EJ dx = [x]_0^b 1/EJ$$

$$= (b) 1/EJ = b/EJ$$

$$L_{DC}^{xx} = \int_0^b (1) 1/EJ dx = [x]_0^b 1/EJ$$

$$= (b) 1/EJ = b/EJ$$

$$L_{DE}^{xx} = \int_0^b (1 - 2x/b + x^2/b^2) 1/EJ dx = [x - x^2/b + 1/3 x^3/b^2]_0^b 1/EJ$$

$$= (b - b + 1/3 b) 1/EJ = 1/3 b/EJ$$

$$L_{ED}^{xx} = \int_0^b (x^2/b^2) 1/EJ dx = [1/3 x^3/b^2]_0^b 1/EJ$$

$$= (1/3 b) 1/EJ = 1/3 b/EJ$$

$$L_{BC}^{xo} = \int_0^b (5/2 x/b - 3/2 x^2/b^2) Fb 1/EJ dx = [5/4 x^2/b - 1/2 x^3/b^2]_0^b Fb 1/EJ$$

$$= (5/4 b - 1/2 b) Fb 1/EJ = 3/4 Fb^2/EJ$$

$$L_{CB}^{xo} = \int_0^b (1 + 1/2 x/b - 3/2 x^2/b^2) Fb 1/EJ dx = [x + 1/4 x^2/b - 1/2 x^3/b^2]_0^b Fb 1/EJ$$

$$= (b + 1/4 b - 1/2 b) Fb 1/EJ = 3/4 Fb^2/EJ$$

$$L_{DE}^{xo} = \int_0^b (3/2 x/b - 2 x^2/b^2 + 1/2 x^3/b^3) Fb 1/EJ dx = [3/4 x^2/b - 2/3 x^3/b^2 + 1/8 x^4/b^3]_0^b Fb 1/EJ$$

$$= (3/4 b - 2/3 b + 1/8 b) Fb 1/EJ = 5/24 Fb^2/EJ$$

$$L_{ED}^{xo} = \int_0^b (x/b - 1/2 x^2/b^2 - 1/2 x^3/b^3) Fb 1/EJ dx = [1/2 x^2/b - 1/6 x^3/b^2 - 1/8 x^4/b^3]_0^b Fb 1/EJ$$

$$= (1/2 b - 1/6 b - 1/8 b) Fb 1/EJ = 5/24 Fb^2/EJ$$

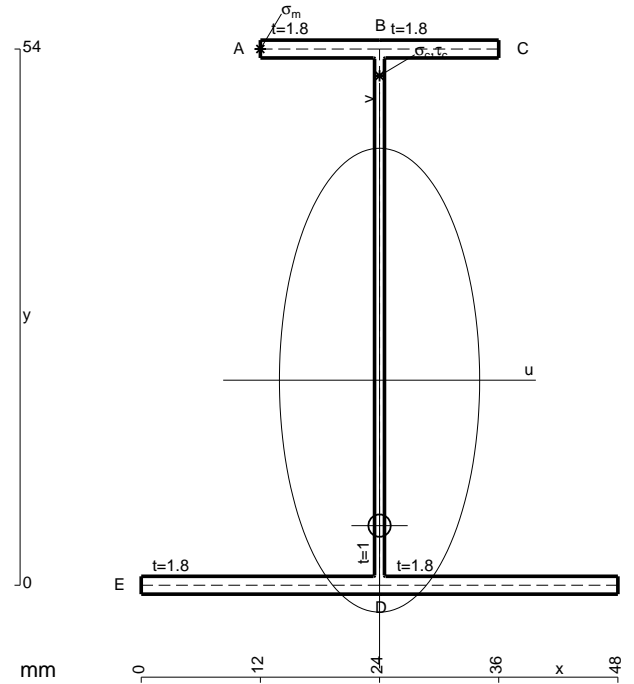

- A = 183.6 mm²
- J_u = 100190. mm⁴
- J_v = 18662. mm⁴
- J_t = 158. mm⁴
- y_o = -14.65 mm
- y_g = 20.65 mm
- N = -920. N
- T_y = -1150. N
- M_x = -644000. Nmm
- x_m = 12. mm
- y_m = 54. mm
- u_m = -12. mm
- v_m = 33.35 mm
- σ_m = N/A-Mv/J_u = 209.4 N/mm²
- x_c = 24. mm
- y_c = 54. mm
- v_c = 33.35 mm
- σ_c = N/A-Mv/J_u = 209.4 N/mm²
- τ_c = TS²/tJ_u = 16.54 N/mm²
- τ_g = TS²/tJ_u = 16.54 N/mm²
- t_c = 460. mm
- σ_o = √σ²+3τ² = 211.3 N/mm²

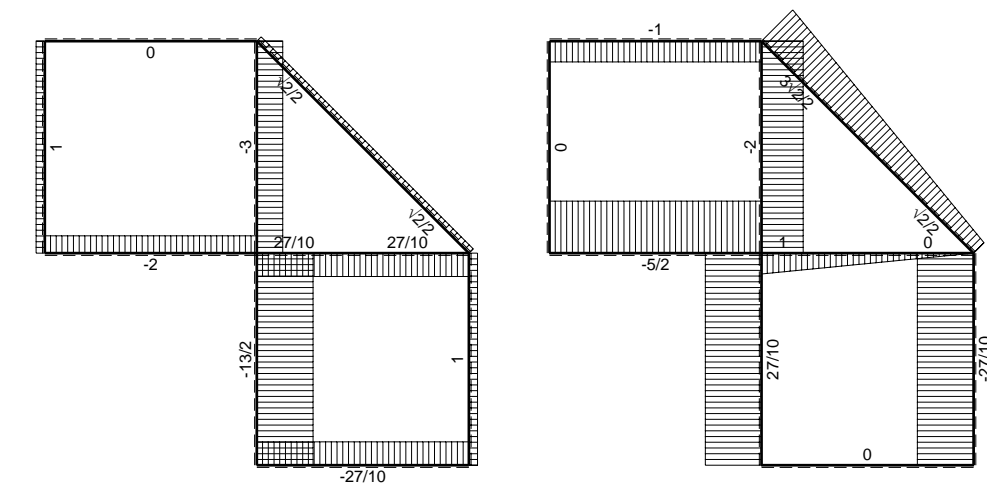
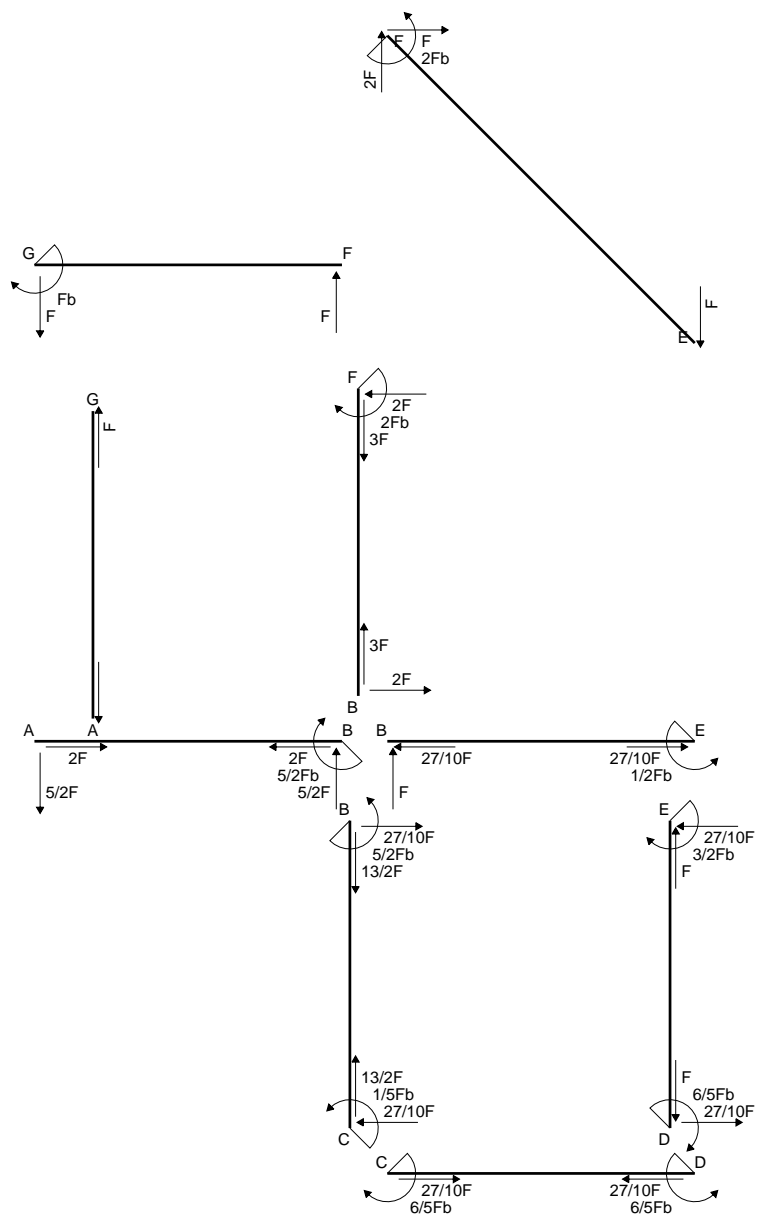

← (+) → F

↑ (+) ↓ F

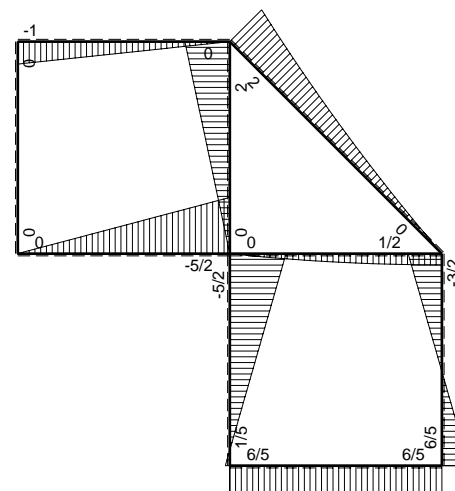

⊙ (+) ⊙ F_b

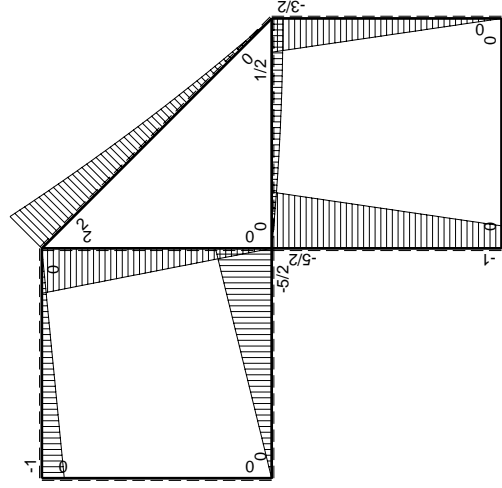
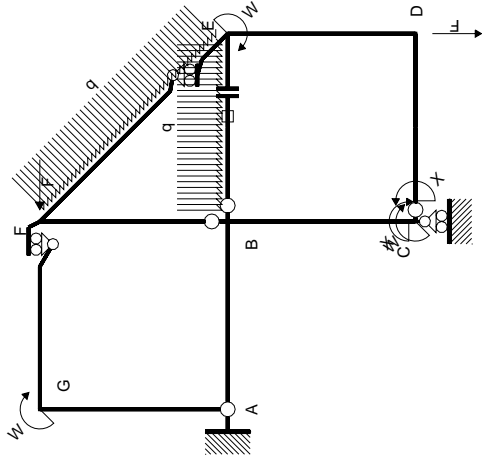

Schema di calcolo iperstatico

M_0 flessione da carichi assegnati

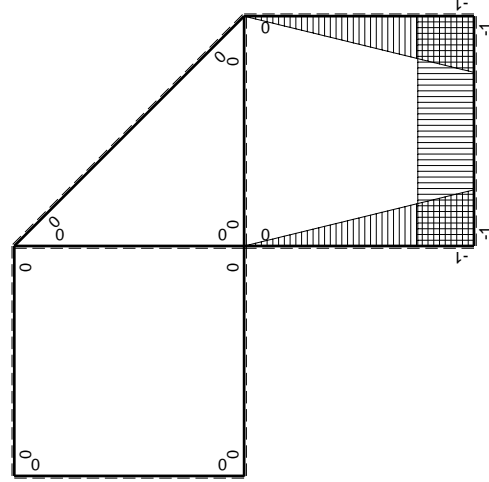

M_x flessione da iperstatica X=1

Quadro contribuiti PLV per iperstatica X=W_{cd}

→	$M_x(x)$	$M_0(x)$	$M_x M_0$	$M_x M_x$	$\int M_x M_0 / EJ dx$	$\int M_x M_x / EJ dx$
AB b	0	-5/2Fx	0	0	0	0
BA b	0	5/2Fb-5/2Fx	0	0	0	0
BC b	-x/b	-5/2Fb+3/2Fx	5/2Fx-3/2Fx ² /b	x ² /b ²	3/4Fb ² /EJ	1/3Xb/EJ
CB b	1-x/b	Fb+3/2Fx	Fb+1/2Fx-3/2Fx ² /b	1-2x/b+x ² /b ²	0	Xb/EJ
CD b	-1	0	0	1	0	0
DC b	1	0	0	1	0	0
DE b	-1+x/b	-3/2Fx	3/2Fx-3/2Fx ² /b	1-2x/b+x ² /b ²	1/4Fb ² /EJ	1/3Xb/EJ
ED b	x/b	3/2Fb-3/2Fx	3/2Fx-3/2Fx ² /b	x ² /b ²	0	0
EF √2b	0	√2/2Fx+1/2qx ²	0	0	0	0
FG b	0	-Fx	0	0	0	0
GF b	0	Fb-Fx	0	0	0	0
GA b	0	0	0	0	0	0
AG b	0	0	0	0	0	0
FB b	0	2Fb-2Fx	0	0	0	0
BF b	0	-2Fx	0	0	0	0
BE b	0	Fx-1/2qx ²	0	0	0	0
EB b	0	-1/2Fb+1/2qx ²	0	0	0	0
BE	elongazione asta $N_{1, BE}^{\epsilon_{BE}} = L_{BE}$				Fb ² /EJ	
	totali				2Fb ² /EJ	5/3Xb/EJ
	iperstatica X=W _{cd}				-6/5Fb	

Sviluppi di calcolo iperstatica

$$L_{BC}^{xx} = \int_0^b (x^2/b^2) 1/EJ dx = [1/3 x^3/b^2]_0^b 1/EJ$$

$$= (1/3 b) 1/EJ = 1/3 b/EJ$$

$$L_{CB}^{xx} = \int_0^b (1 - 2x/b + x^2/b^2) 1/EJ dx = [x - x^2/b + 1/3 x^3/b^2]_0^b 1/EJ$$

$$= (b - b + 1/3 b) 1/EJ = 1/3 b/EJ$$

$$L_{CD}^{xx} = \int_0^b (1) 1/EJ dx = [x]_0^b 1/EJ$$

$$= (b) 1/EJ = b/EJ$$

$$L_{DC}^{xx} = \int_0^b (1) 1/EJ dx = [x]_0^b 1/EJ$$

$$= (b) 1/EJ = b/EJ$$

$$L_{DE}^{xx} = \int_0^b (1 - 2x/b + x^2/b^2) 1/EJ dx = [x - x^2/b + 1/3 x^3/b^2]_0^b 1/EJ$$

$$= (b - b + 1/3 b) 1/EJ = 1/3 b/EJ$$

$$L_{ED}^{xx} = \int_0^b (x^2/b^2) 1/EJ dx = [1/3 x^3/b^2]_0^b 1/EJ$$

$$= (1/3 b) 1/EJ = 1/3 b/EJ$$

$$L_{BC}^{xo} = \int_0^b (5/2 x/b - 3/2 x^2/b^2) Fb 1/EJ dx = [5/4 x^2/b - 1/2 x^3/b^2]_0^b Fb 1/EJ$$

$$= (5/4 b - 1/2 b) Fb 1/EJ = 3/4 Fb^2/EJ$$

$$L_{CB}^{xo} = \int_0^b (1 + 1/2 x/b - 3/2 x^2/b^2) Fb 1/EJ dx = [x + 1/4 x^2/b - 1/2 x^3/b^2]_0^b Fb 1/EJ$$

$$= (b + 1/4 b - 1/2 b) Fb 1/EJ = 3/4 Fb^2/EJ$$

$$L_{DE}^{xo} = \int_0^b (3/2 x/b - 3/2 x^2/b^2) Fb 1/EJ dx = [3/4 x^2/b - 1/2 x^3/b^2]_0^b Fb 1/EJ$$

$$= (3/4 b - 1/2 b) Fb 1/EJ = 1/4 Fb^2/EJ$$

$$L_{ED}^{xo} = \int_0^b (3/2 x/b - 3/2 x^2/b^2) Fb 1/EJ dx = [3/4 x^2/b - 1/2 x^3/b^2]_0^b Fb 1/EJ$$

$$= (3/4 b - 1/2 b) Fb 1/EJ = 1/4 Fb^2/EJ$$

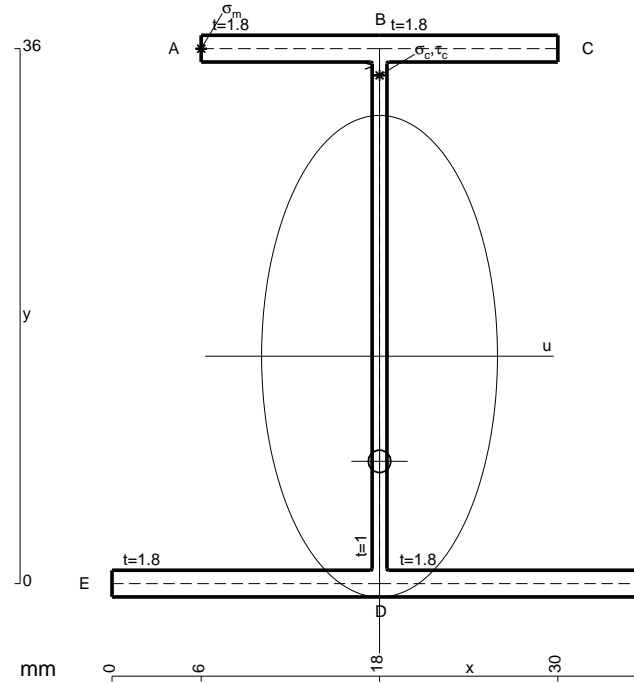

- A = 144. mm²
- J_u = 37830. mm⁴
- J_v = 9072. mm⁴
- J_t = 128.6 mm⁴
- y_o = -7.071 mm
- y_g = 15.3 mm
- N = -820. N
- T_y = -1025. N
- M_x = -410000. Nmm
- x_m = 6. mm
- y_m = 36. mm
- u_m = -12. mm
- v_m = 20.7 mm
- σ_m = N/A - Mv/J_u = 218.6 N/mm²
- x_c = 18. mm
- y_c = 36. mm
- v_c = 20.7 mm
- σ_c = N/A - Mv/J_u = 218.6 N/mm²
- τ_c = TS_y/tJ_u = 24.23 N/mm²
- τ_g = TS_y/tJ_u = 24.23 N/mm²
- t_c = 410. mm
- σ_o = √(σ² + 3τ²) = 222.6 N/mm²

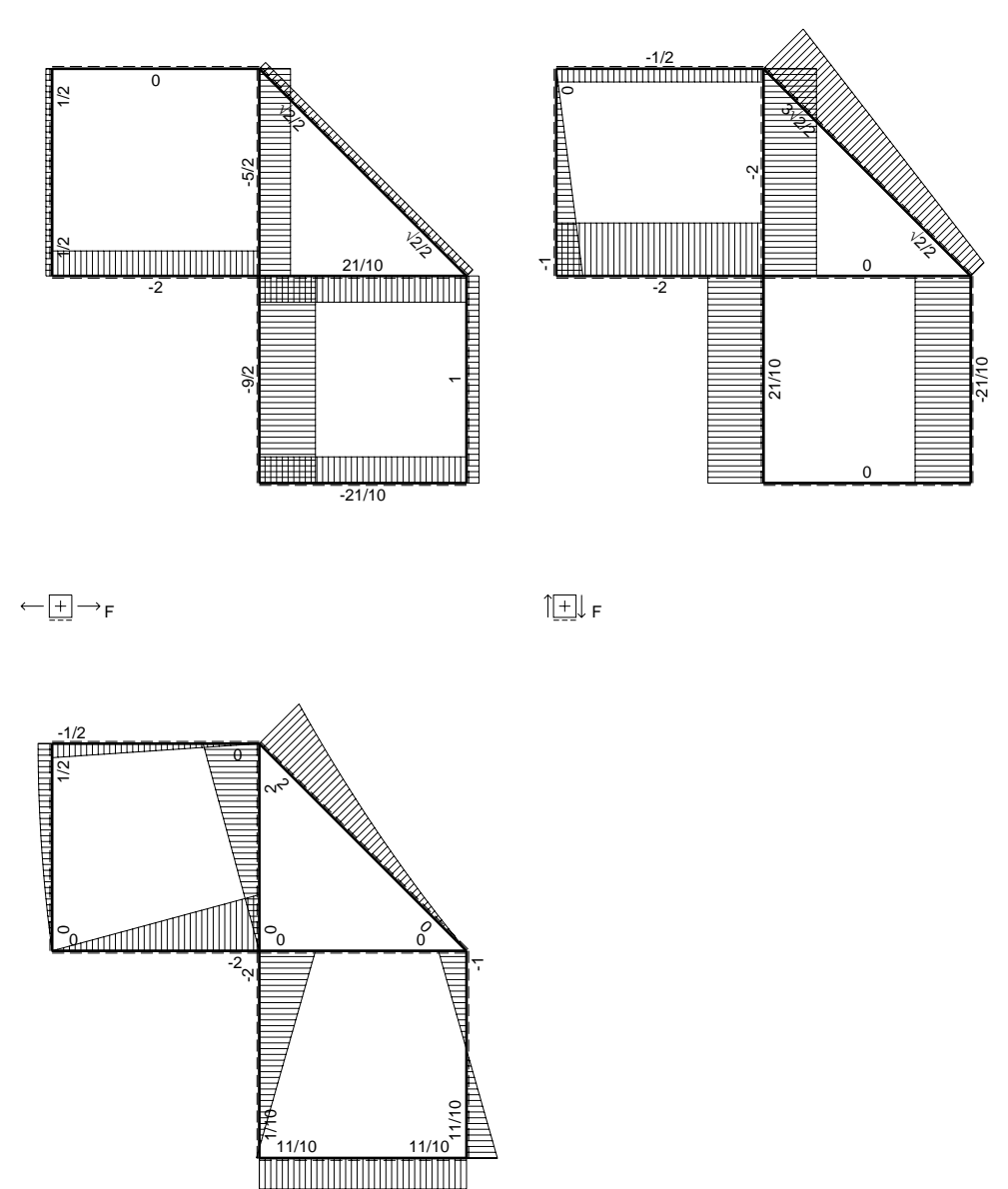
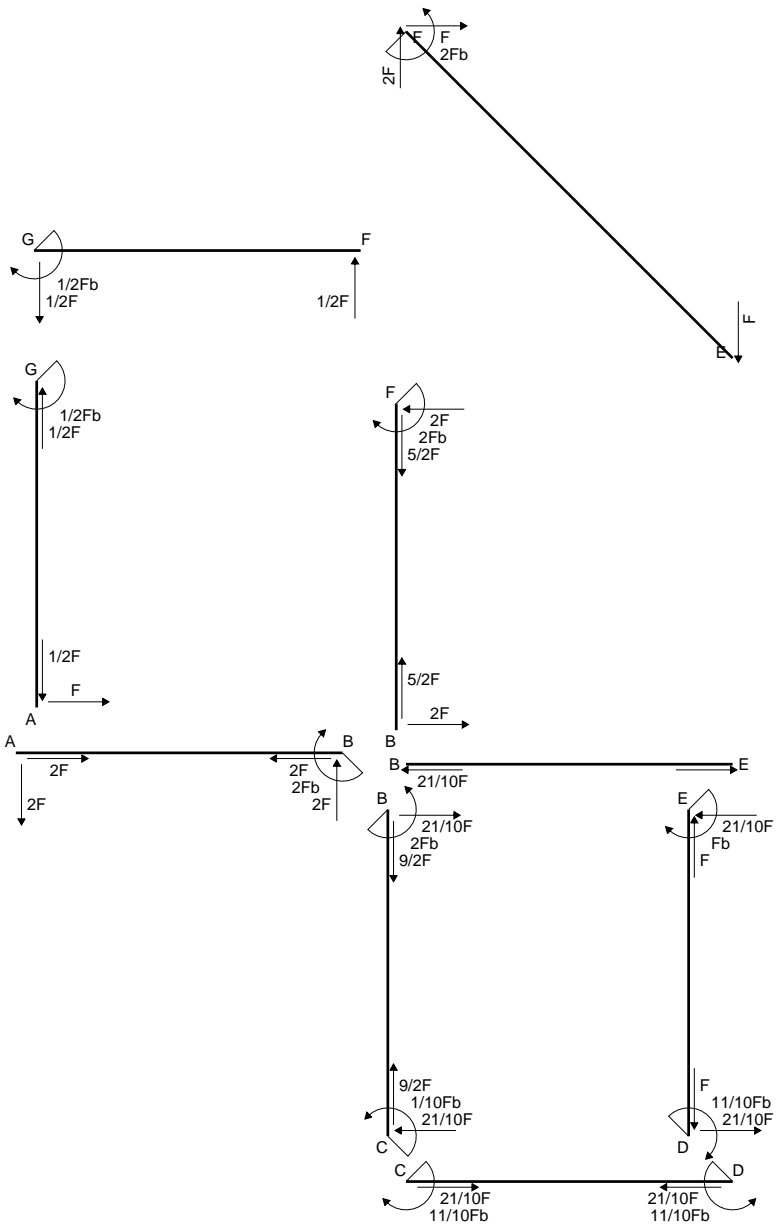

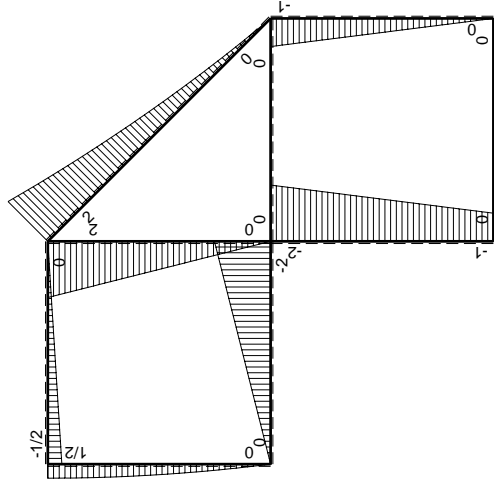
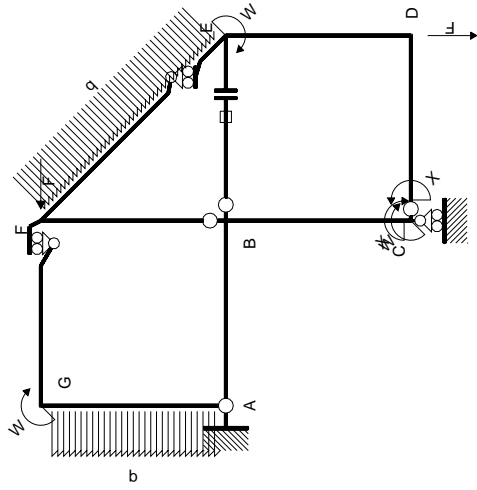

Schema di calcolo iperstatico

M_0 flessione da carichi assegnati

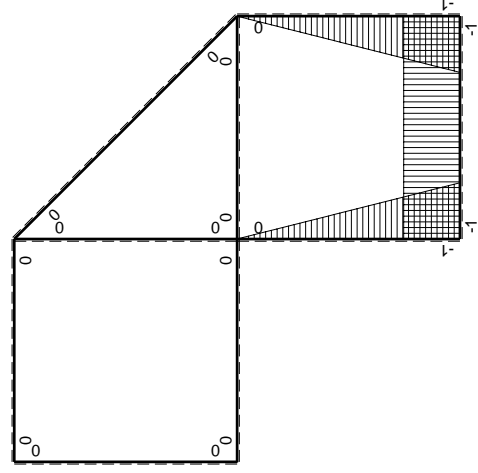

M_x flessione da iperstatica $X=1$

Quadro contribuiti PLV per iperstatica $X=W_{cd}$

\rightarrow	$M_x(x)$	$M_0(x)$	$M_x M_0$	$M_x M_x$	$\int M_x M_0 / E J dx$	$\int M_x M_x / E J dx$
AB b	0	-2Fx	0	0	0	0
BA b	0	2Fb-2Fx	0	0	0	0
BC b	-x/b	-2Fb+Fx	$2Fx-Fx^2/b$	x^2/b^2	$2/3Fb^2/EJ$	$1/3Xb/EJ$
CB b	1-x/b	Fb+Fx	$Fb-Fx^2/b$	$1-2x/b+x^2/b^2$	0	0
CD b	-1	0	0	1	0	Xb/EJ
DC b	1	0	0	1	0	0
DE b	-1+x/b	-Fx	$Fx-Fx^2/b$	$1-2x/b+x^2/b^2$	$1/6Fb^2/EJ$	$1/3Xb/EJ$
ED b	x/b	Fb-Fx	$Fx-Fx^2/b$	x^2/b^2	0	0
EF $\sqrt{2}b$	0	$\sqrt{2}/2Fx+1/2qx^2$	0	0	0	0
FG b	0	-1/2Fx	0	0	0	0
GF b	0	1/2Fb-1/2Fx	0	0	0	0
GA b	0	1/2Fb-1/2qx^2	0	0	0	0
AG b	0	-Fx+1/2qx^2	0	0	0	0
FB b	0	2Fb-2Fx	0	0	0	0
BF b	0	-2Fx	0	0	0	0
BE b	0	0	0	0	0	0
EB b	0	0	0	0	0	0
BE	elongazione asta $N_{1, BE} \epsilon_{BE} L_{BE}$				Fb^2/EJ	
	totali				$11/6Fb^2/EJ$	$5/3Xb/EJ$
	iperstatica $X=W_{cd}$					$-11/10Fb$

Sviluppi di calcolo iperstatica

$$L_{BC}^{xx} = \int_0^b (x^2/b^2) 1/EJ dx = [1/3 x^3/b^2]_0^b 1/EJ$$

$$= (1/3 b) 1/EJ = 1/3 b/EJ$$

$$L_{CB}^{xx} = \int_0^b (1 - 2x/b + x^2/b^2) 1/EJ dx = [x - x^2/b + 1/3 x^3/b^2]_0^b 1/EJ$$

$$= (b - b + 1/3 b) 1/EJ = 1/3 b/EJ$$

$$L_{CD}^{xx} = \int_0^b (1) 1/EJ dx = [x]_0^b 1/EJ$$

$$= (b) 1/EJ = b/EJ$$

$$L_{DC}^{xx} = \int_0^b (1) 1/EJ dx = [x]_0^b 1/EJ$$

$$= (b) 1/EJ = b/EJ$$

$$L_{DE}^{xx} = \int_0^b (1 - 2x/b + x^2/b^2) 1/EJ dx = [x - x^2/b + 1/3 x^3/b^2]_0^b 1/EJ$$

$$= (b - b + 1/3 b) 1/EJ = 1/3 b/EJ$$

$$L_{ED}^{xx} = \int_0^b (x^2/b^2) 1/EJ dx = [1/3 x^3/b^2]_0^b 1/EJ$$

$$= (1/3 b) 1/EJ = 1/3 b/EJ$$

$$L_{BC}^{xo} = \int_0^b (2x/b - x^2/b^2) Fb 1/EJ dx = [x^2/b - 1/3 x^3/b^2]_0^b Fb 1/EJ$$

$$= (b - 1/3 b) Fb 1/EJ = 2/3 Fb^2/EJ$$

$$L_{CB}^{xo} = \int_0^b (1 - x^2/b^2) Fb 1/EJ dx = [x - 1/3 x^3/b^2]_0^b Fb 1/EJ$$

$$= (b - 1/3 b) Fb 1/EJ = 2/3 Fb^2/EJ$$

$$L_{DE}^{xo} = \int_0^b (x/b - x^2/b^2) Fb 1/EJ dx = [1/2 x^2/b - 1/3 x^3/b^2]_0^b Fb 1/EJ$$

$$= (1/2 b - 1/3 b) Fb 1/EJ = 1/6 Fb^2/EJ$$

$$L_{ED}^{xo} = \int_0^b (x/b - x^2/b^2) Fb 1/EJ dx = [1/2 x^2/b - 1/3 x^3/b^2]_0^b Fb 1/EJ$$

$$= (1/2 b - 1/3 b) Fb 1/EJ = 1/6 Fb^2/EJ$$

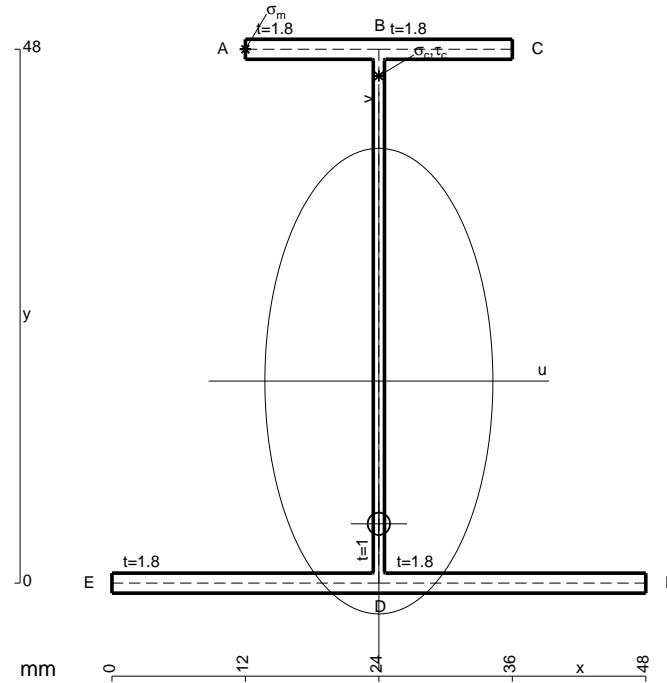

- A = 177.6 mm²
- J_u = 77813. mm⁴
- J_v = 18662. mm⁴
- J_i = 156. mm⁴
- y_o = -12.83 mm
- y_g = 18.16 mm
- N = 367.7 N
- T_y = 1103. N
- M_x = 603200. Nmm
- x_m = 12. mm
- y_m = 48. mm
- u_m = -12. mm
- v_m = 29.84 mm
- σ_m = N/A - Mv/J_u = -229.2 N/mm²
- x_c = 24. mm
- y_c = 48. mm
- v_c = 29.84 mm
- σ_c = N/A - Mv/J_u = -229.2 N/mm²
- τ_c = TS/tJ_u = 18.27 N/mm²
- τ_g = TS/tJ_u = 18.27 N/mm²
- t_c = 520. mm
- σ_o = √σ² + 3τ² = 231.4 N/mm²

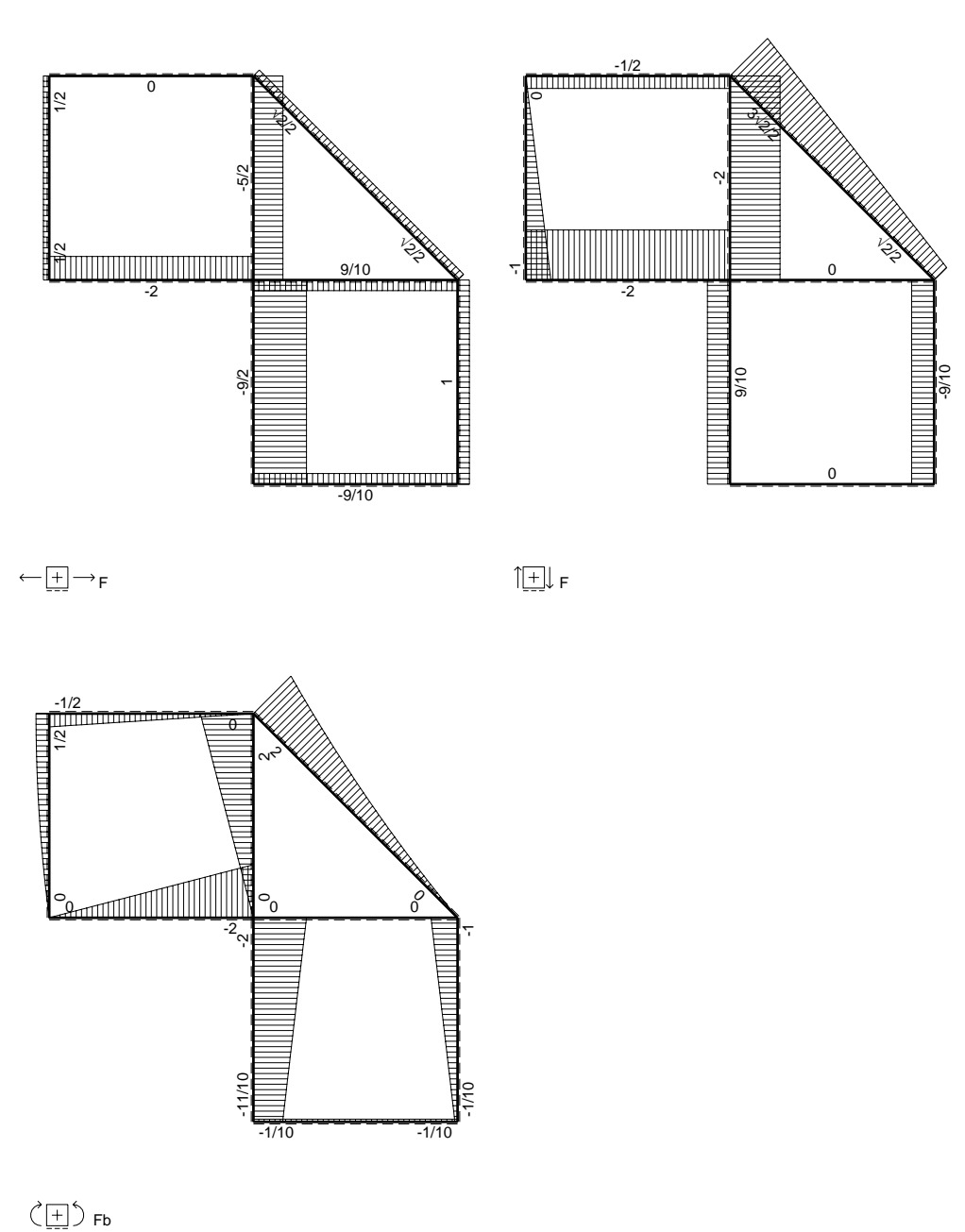
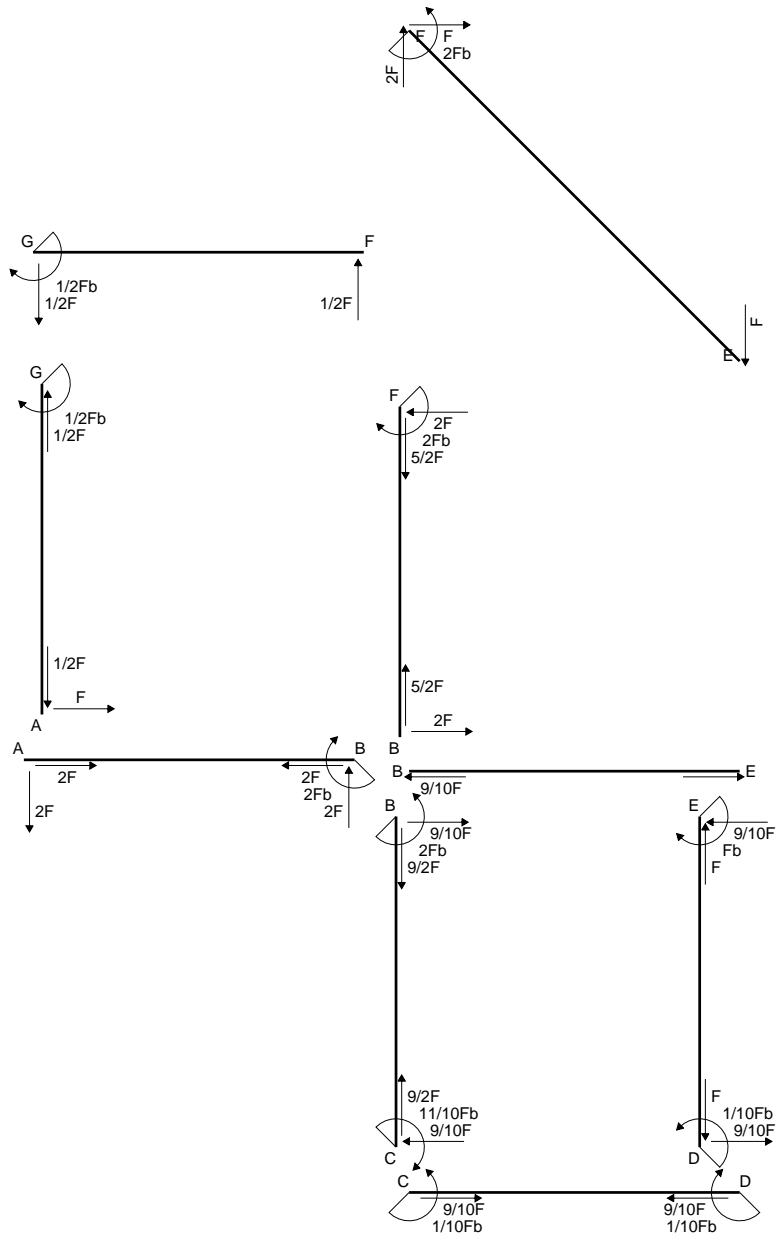

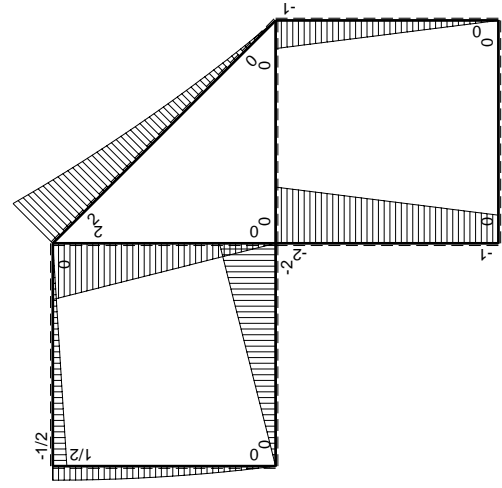
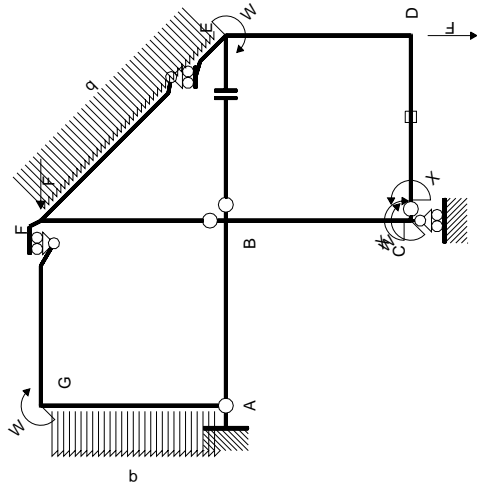

Schema di calcolo iperstatico

M_0 flessione da carichi assegnati

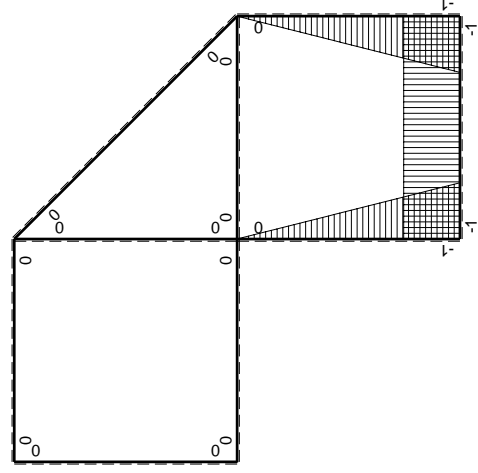

M_x flessione da iperstatica $X=1$

Quadro contribuiti PLV per iperstatica $X=W_{cd}$

\rightarrow	$M_x(x)$	$M_0(x)$	$M_x M_0$	$M_x M_x$	$\int M_x M_0 / EJ dx$	$\int M_x M_x / EJ dx$
AB b	0	-2Fx	0	0	0	0
BA b	0	2Fb-2Fx	0	0	0	0
BC b	-x/b	-2Fb+Fx	2Fx-Fx ² /b	x ² /b ²	2/3Fb ² /EJ	1/3Xb/EJ
CB b	1-x/b	Fb+Fx	Fb-Fx ² /b	1-2x/b+x ² /b ²		
CD b	-1	0	0	1	0	Xb/EJ
DC b	1	0	0	1	0	
DE b	-1+x/b	-Fx	Fx-Fx ² /b	1-2x/b+x ² /b ²	1/6Fb ² /EJ	1/3Xb/EJ
ED b	x/b	Fb-Fx	Fx-Fx ² /b	x ² /b ²		
EF $\sqrt{2}b$	0	$\sqrt{2}/2Fx+1/2qx^2$	0	0	0	0
FG b	0	-1/2Fx	0	0	0	0
GF b	0	1/2Fb-1/2Fx	0	0	0	0
GA b	0	1/2Fb-1/2qx ²	0	0	0	0
AG b	0	-Fx+1/2qx ²	0	0	0	0
FB b	0	2Fb-2Fx	0	0	0	0
BF b	0	-2Fx	0	0	0	0
BE b	0	0	0	0	0	0
EB b	0	0	0	0	0	0
CD	elongazione asta $N_{1,cd} \epsilon_{cd} L_{cd}$				-Fb ² /EJ	
	totali				-1/6Fb ² /EJ	5/3Xb/EJ
	iperstatica $X=W_{cd}$				1/10Fb	

Sviluppi di calcolo iperstatica

$$L_{BC}^{xx} = \int_0^b (x^2/b^2) 1/EJ dx = [1/3 x^3/b^2]_0^b 1/EJ$$

$$= (1/3 b) 1/EJ = 1/3 b/EJ$$

$$L_{CB}^{xx} = \int_0^b (1 - 2x/b + x^2/b^2) 1/EJ dx = [x - x^2/b + 1/3 x^3/b^2]_0^b 1/EJ$$

$$= (b - b + 1/3 b) 1/EJ = 1/3 b/EJ$$

$$L_{CD}^{xx} = \int_0^b (1) 1/EJ dx = [x]_0^b 1/EJ$$

$$= (b) 1/EJ = b/EJ$$

$$L_{DC}^{xx} = \int_0^b (1) 1/EJ dx = [x]_0^b 1/EJ$$

$$= (b) 1/EJ = b/EJ$$

$$L_{DE}^{xx} = \int_0^b (1 - 2x/b + x^2/b^2) 1/EJ dx = [x - x^2/b + 1/3 x^3/b^2]_0^b 1/EJ$$

$$= (b - b + 1/3 b) 1/EJ = 1/3 b/EJ$$

$$L_{ED}^{xx} = \int_0^b (x^2/b^2) 1/EJ dx = [1/3 x^3/b^2]_0^b 1/EJ$$

$$= (1/3 b) 1/EJ = 1/3 b/EJ$$

$$L_{BC}^{xo} = \int_0^b (2x/b - x^2/b^2) Fb 1/EJ dx = [x^2/b - 1/3 x^3/b^2]_0^b Fb 1/EJ$$

$$= (b - 1/3 b) Fb 1/EJ = 2/3 Fb^2/EJ$$

$$L_{CB}^{xo} = \int_0^b (1 - x^2/b^2) Fb 1/EJ dx = [x - 1/3 x^3/b^2]_0^b Fb 1/EJ$$

$$= (b - 1/3 b) Fb 1/EJ = 2/3 Fb^2/EJ$$

$$L_{DE}^{xo} = \int_0^b (x/b - x^2/b^2) Fb 1/EJ dx = [1/2 x^2/b - 1/3 x^3/b^2]_0^b Fb 1/EJ$$

$$= (1/2 b - 1/3 b) Fb 1/EJ = 1/6 Fb^2/EJ$$

$$L_{ED}^{xo} = \int_0^b (x/b - x^2/b^2) Fb 1/EJ dx = [1/2 x^2/b - 1/3 x^3/b^2]_0^b Fb 1/EJ$$

$$= (1/2 b - 1/3 b) Fb 1/EJ = 1/6 Fb^2/EJ$$

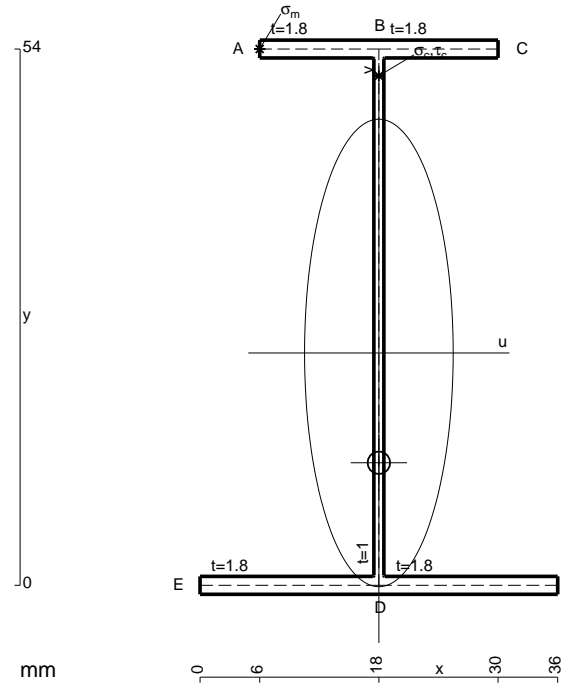

- A = 162. mm²
- J_u = 89755. mm⁴
- J_v = 9072. mm⁴
- J_i = 134.6 mm⁴
- y_o = -11.06 mm
- y_g = 23.4 mm
- N = 353.6 N
- T_y = 1061. N
- M_x = 71000. Nmm
- x_m = 6. mm
- y_m = 54. mm
- u_m = -12. mm
- v_m = 30.6 mm
- σ_m = N/A-Mv/J_u = -239.9 N/mm²
- x_c = 18. mm
- y_c = 54. mm
- v_c = 30.6 mm
- σ_c = N/A-Mv/J_u = -239.9 N/mm²
- τ_c = TS/tJ_u = 15.62 N/mm²
- τ_g = TS/tJ_u = 15.62 N/mm²
- t_c = 500. mm
- σ_o = √σ²+3τ² = 241.4 N/mm²

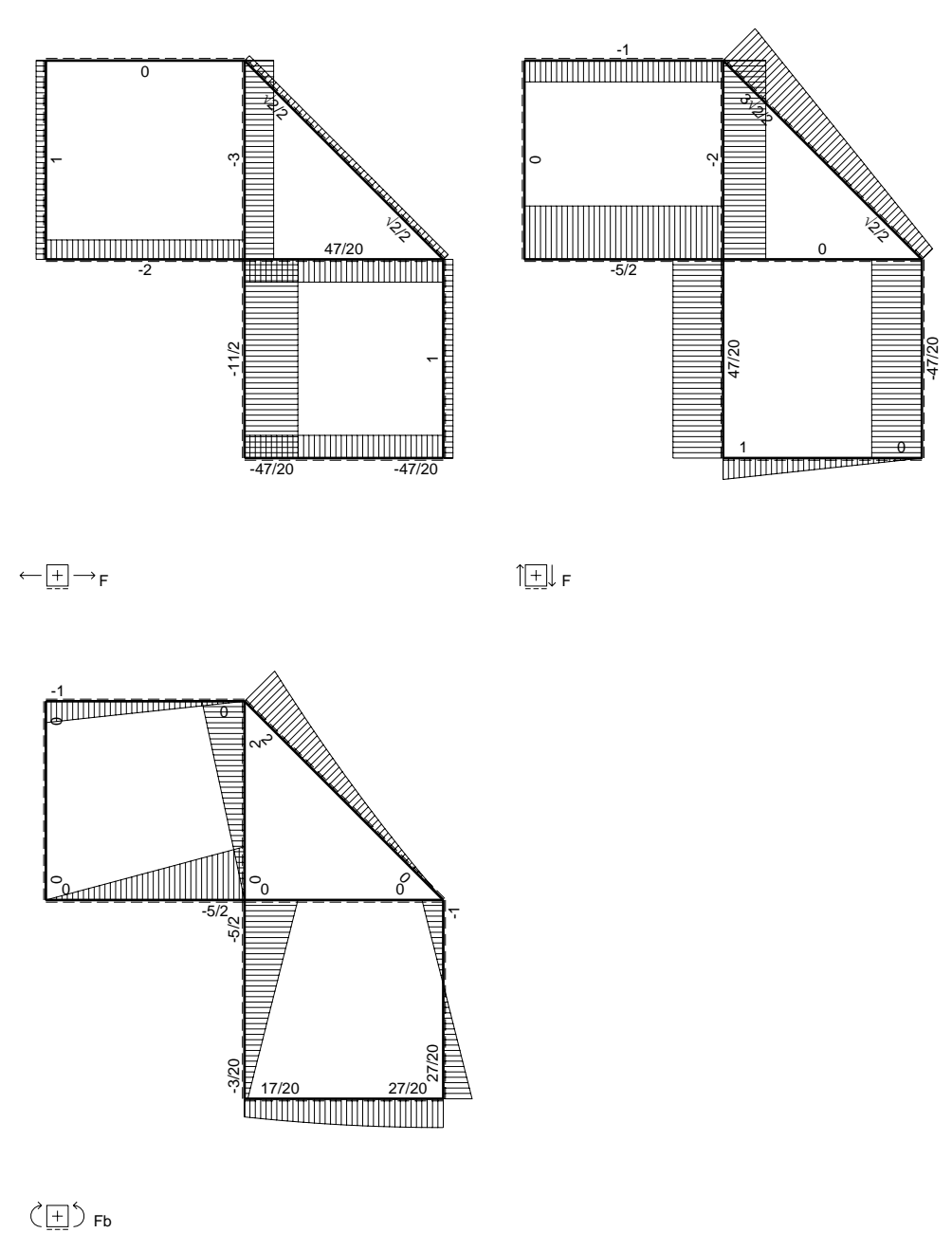
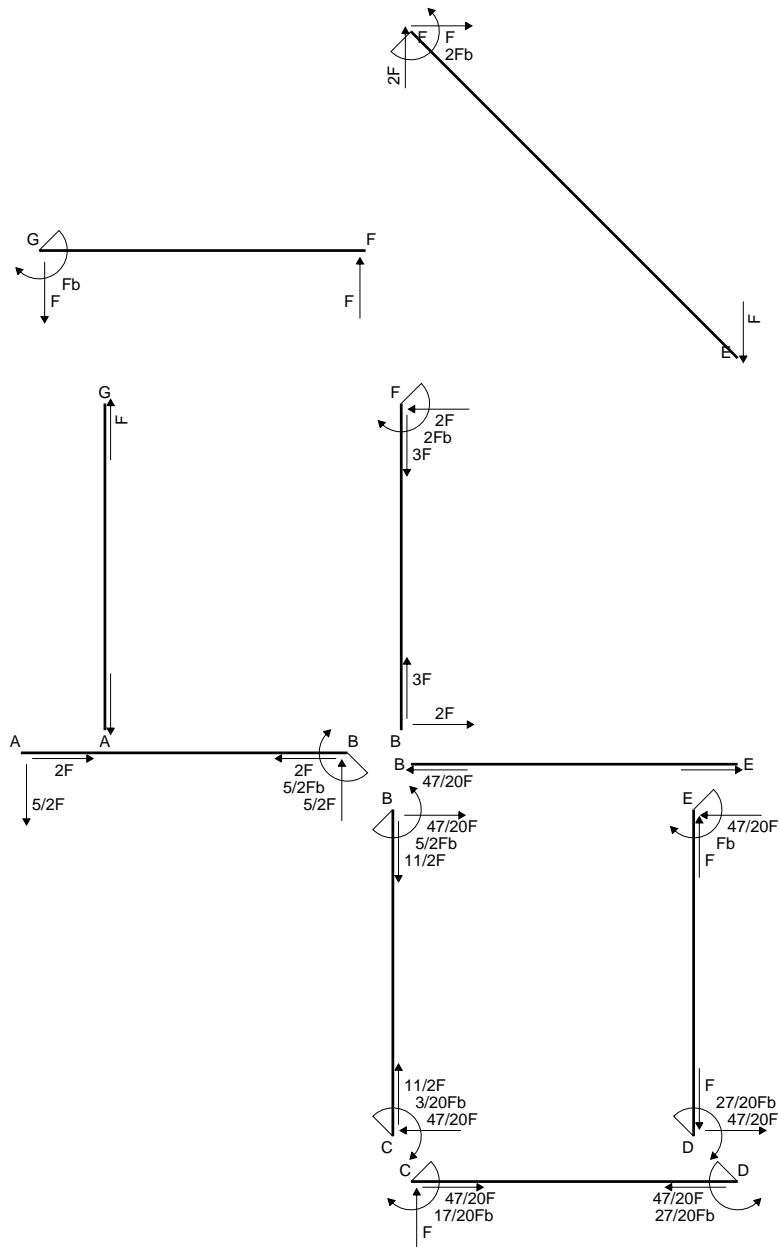

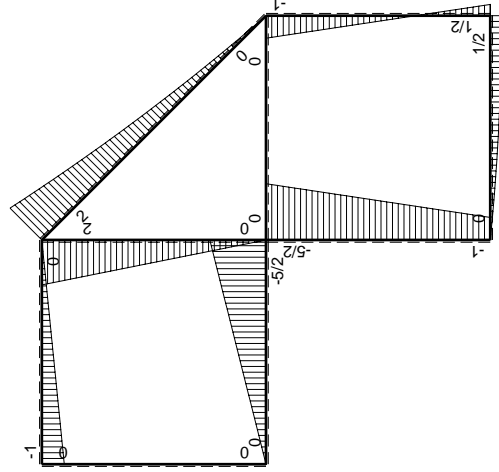
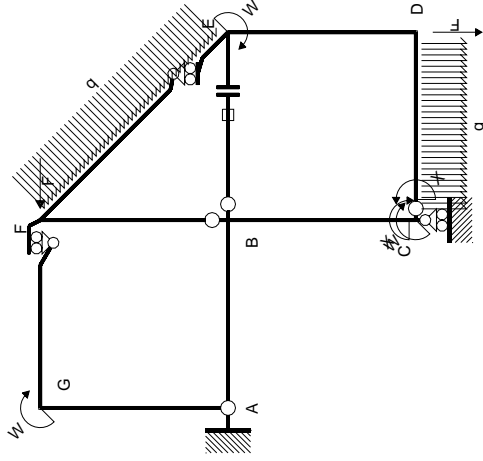

Schema di calcolo iperstatico

M_0 flessione da carichi assegnati

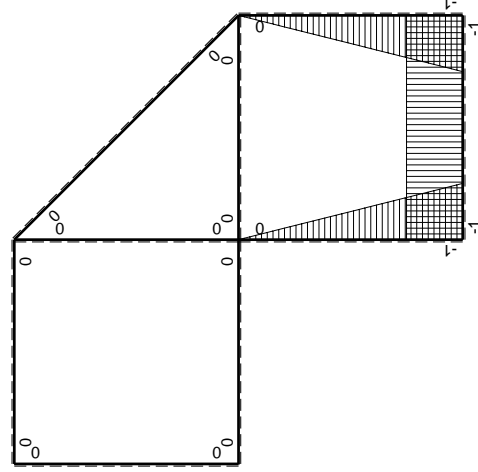

M_x flessione da iperstatica $X=1$

Quadro contribuiti PLV per iperstatica $X=W_{cd}$

\rightarrow	$M_x(x)$	$M_0(x)$	$M_x M_0$	$M_x M_x$	$\int M_x M_0 / EJ dx$	$\int M_x M_x / EJ dx$
AB b	0	-5/2Fx	0	0	0	0
BA b	0	5/2Fb-5/2Fx	0	0	0	0
BC b	-x/b	-5/2Fb+3/2Fx	5/2Fx-3/2Fx ² /b	x ² /b ²	3/4Fb ² /EJ	1/3Xb/EJ
CB b	1-x/b	Fb+3/2Fx	Fb+1/2Fx-3/2Fx ² /b	1-2x/b+x ² /b ²	-1/3Fb ² /EJ	Xb/EJ
CD b	-1	Fx-1/2qx ²	-Fx+1/2Fx ² /b	1	-1/3Fb ² /EJ	Xb/EJ
DC b	1	-1/2Fb+1/2qx ²	-1/2Fb+1/2Fx ² /b	1	-1/3Fb ² /EJ	Xb/EJ
DE b	-1+x/b	1/2Fb-3/2Fx	-1/2Fb+2Fx-3/2Fx ² /b	1-2x/b+x ² /b ²	0	1/3Xb/EJ
ED b	x/b	Fb-3/2Fx	Fx-3/2Fx ² /b	x ² /b ²	0	1/3Xb/EJ
EF $\sqrt{2}b$	0	$\sqrt{2}/2Fx+1/2qx^2$	0	0	0	0
FG b	0	-Fx	0	0	0	0
GF b	0	Fb-Fx	0	0	0	0
GA b	0	0	0	0	0	0
AG b	0	0	0	0	0	0
FB b	0	2Fb-2Fx	0	0	0	0
BF b	0	-2Fx	0	0	0	0
BE b	0	0	0	0	0	0
EB b	0	0	0	0	0	0
BE	elongazione asta $N_{1, BE} \epsilon_{BE} L_{BE}$				Fb ² /EJ	
	totali				17/12Fb ² /EJ	5/3Xb/EJ
	iperstatica $X=W_{cd}$				-17/20Fb	

Sviluppi di calcolo iperstatica

$$L_{BC}^{xx} = \int_0^b (x^2/b^2) 1/EJ dx = [1/3 x^3/b^2]_0^b 1/EJ$$

$$= (1/3 b) 1/EJ = 1/3 b/EJ$$

$$L_{CB}^{xx} = \int_0^b (1 - 2x/b + x^2/b^2) 1/EJ dx = [x - x^2/b + 1/3 x^3/b^2]_0^b 1/EJ$$

$$= (b - b + 1/3 b) 1/EJ = 1/3 b/EJ$$

$$L_{CD}^{xx} = \int_0^b (1) 1/EJ dx = [x]_0^b 1/EJ$$

$$= (b) 1/EJ = b/EJ$$

$$L_{DC}^{xx} = \int_0^b (1) 1/EJ dx = [x]_0^b 1/EJ$$

$$= (b) 1/EJ = b/EJ$$

$$L_{DE}^{xx} = \int_0^b (1 - 2x/b + x^2/b^2) 1/EJ dx = [x - x^2/b + 1/3 x^3/b^2]_0^b 1/EJ$$

$$= (b - b + 1/3 b) 1/EJ = 1/3 b/EJ$$

$$L_{ED}^{xx} = \int_0^b (x^2/b^2) 1/EJ dx = [1/3 x^3/b^2]_0^b 1/EJ$$

$$= (1/3 b) 1/EJ = 1/3 b/EJ$$

$$L_{BC}^{xo} = \int_0^b (5/2 x/b - 3/2 x^2/b^2) Fb 1/EJ dx = [5/4 x^2/b - 1/2 x^3/b^2]_0^b Fb 1/EJ$$

$$= (5/4 b - 1/2 b) Fb 1/EJ = 3/4 Fb^2/EJ$$

$$L_{CB}^{xo} = \int_0^b (1 + 1/2 x/b - 3/2 x^2/b^2) Fb 1/EJ dx = [x + 1/4 x^2/b - 1/2 x^3/b^2]_0^b Fb 1/EJ$$

$$= (b + 1/4 b - 1/2 b) Fb 1/EJ = 3/4 Fb^2/EJ$$

$$L_{CD}^{xo} = \int_0^b (-x/b + 1/2 x^2/b^2) Fb 1/EJ dx = [-1/2 x^2/b + 1/6 x^3/b^2]_0^b Fb 1/EJ$$

$$= (-1/2 b + 1/6 b) Fb 1/EJ = -1/3 Fb^2/EJ$$

$$L_{DC}^{xo} = \int_0^b (-1/2 + 1/2 x^2/b^2) Fb 1/EJ dx = [-1/2 x + 1/6 x^3/b^2]_0^b Fb 1/EJ$$

$$= (-1/2 b + 1/6 b) Fb 1/EJ = -1/3 Fb^2/EJ$$

$$L_{DE}^{xo} = \int_0^b (-1/2 + 2x/b - 3/2 x^2/b^2) Fb 1/EJ dx = [-1/2 x + x^2/b - 1/2 x^3/b^2]_0^b Fb 1/EJ$$

$$= (-1/2 b + b - 1/2 b) Fb 1/EJ = 0$$

$$L_{ED}^{xo} = \int_0^b (x/b - 3/2 x^2/b^2) Fb 1/EJ dx = [1/2 x^2/b - 1/2 x^3/b^2]_0^b Fb 1/EJ$$

$$= (1/2 b - 1/2 b) Fb 1/EJ = 0$$

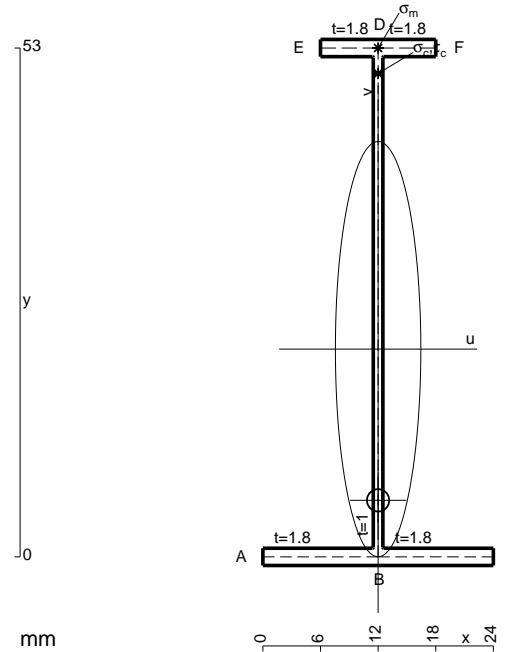

- A = 117.8 mm²
- J_u = 55131. mm⁴
- J_v = 2333. mm⁴
- J_t = 87.65 mm⁴
- y_o = -15.75 mm
- y_g = 21.64 mm
- N = -380. N
- T_y = -475. N
- M_x = -356250. Nmm
- x_m = 12. mm
- y_m = 53. mm
- v_m = 31.36 mm
- σ_m = N/A-Mv/J_u = 199.4 N/mm²
- y_c = 2. mm
- u_c = -12. mm
- v_c = -19.64 mm
- σ_c = N/A-Mv/J_u = 199.4 N/mm²
- τ_c = TS'/tJ_u = 5.836 N/mm²
- τ_g = TS'/tJ_u = 5.836 N/mm²
- t_c = 190. mm
- σ_o = √σ²+3τ² = 199.7 N/mm²

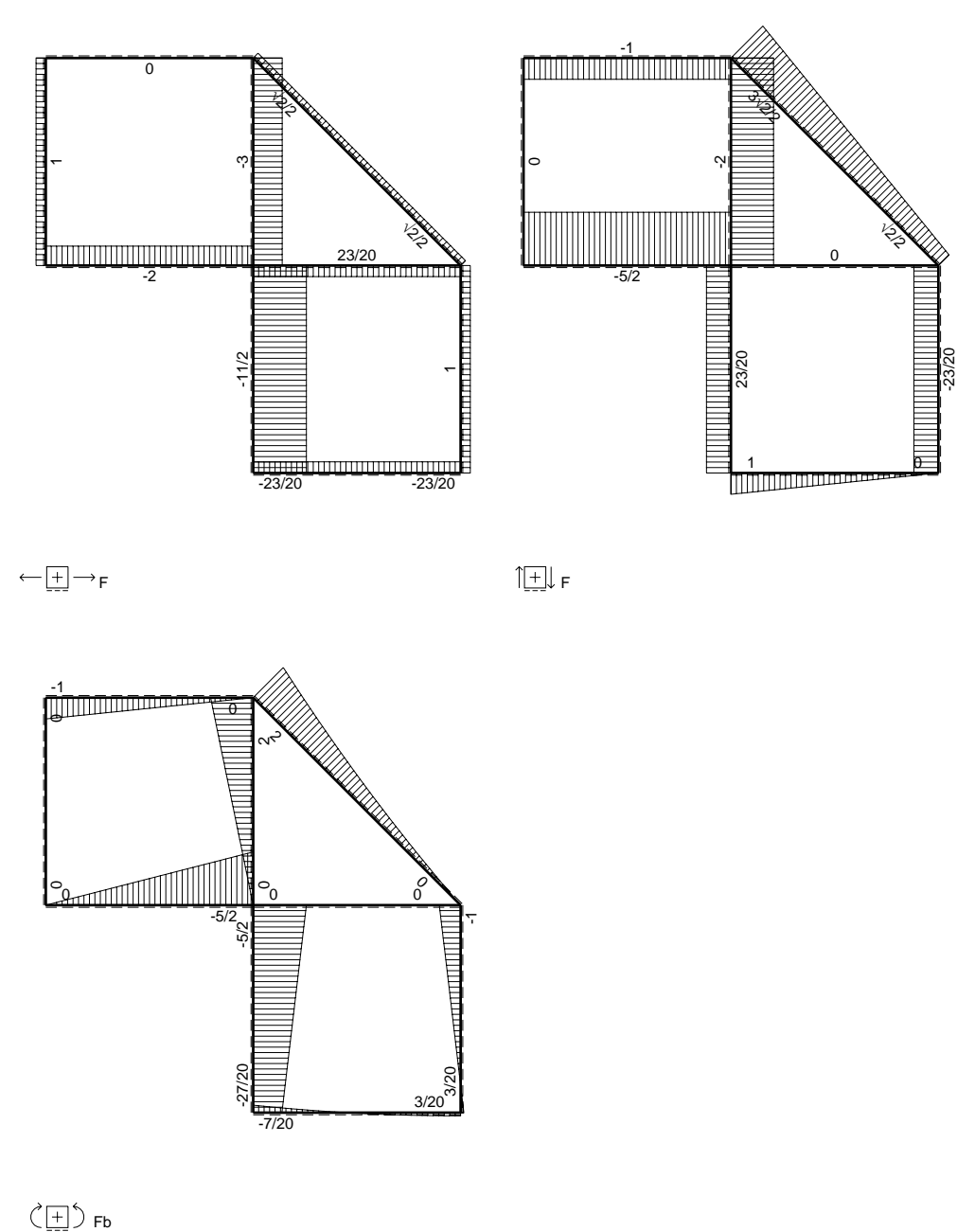
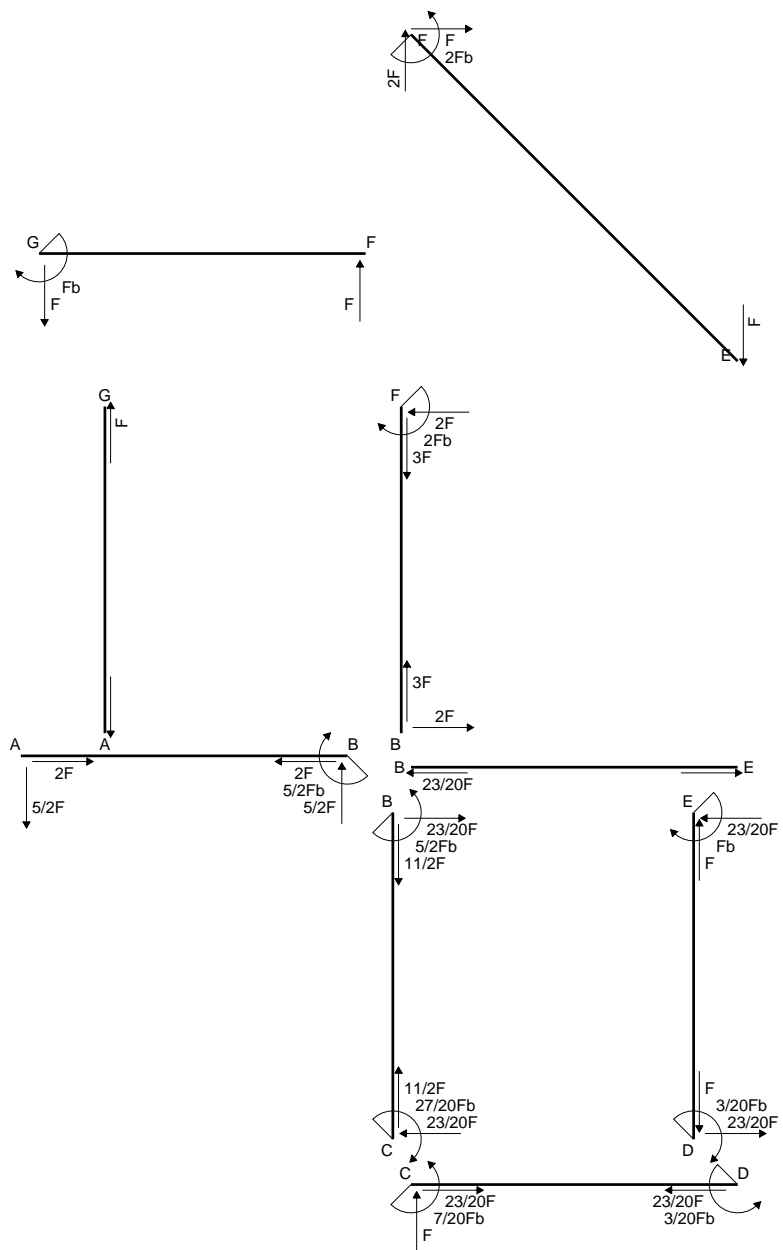

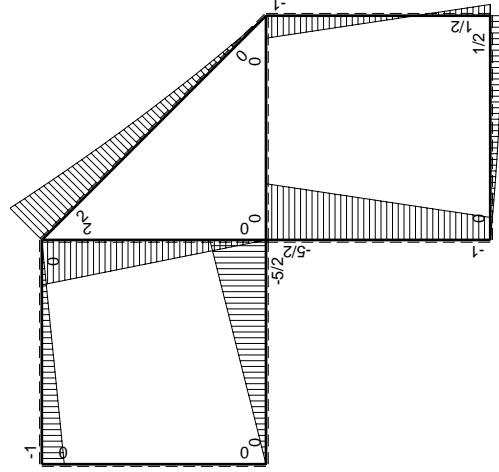
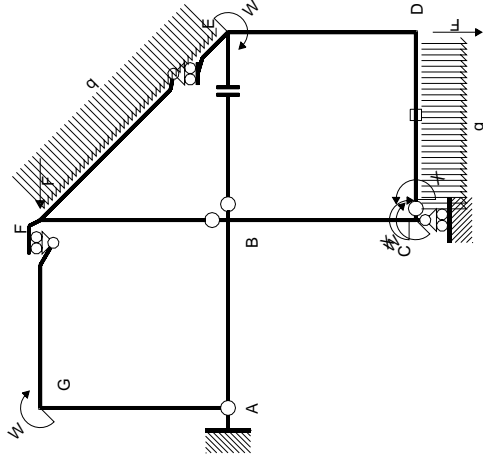

Schema di calcolo iperstatico

M₀ flessione da carichi assegnati

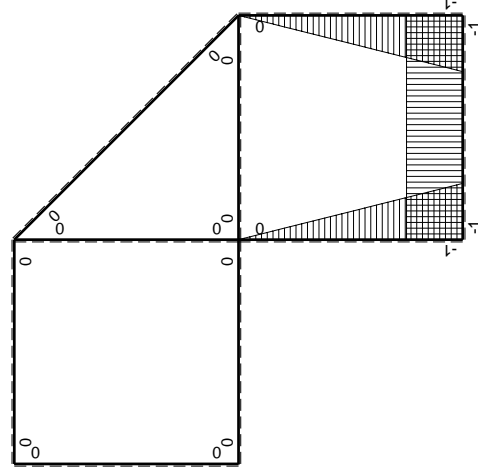

M_x flessione da iperstatica X=1

Quadro contribuiti PLV per iperstatica X=W_{CD}

→	M _x (x)	M ₀ (x)	M _x M ₀	M _x M _x	∫M _x M ₀ /EJdx	∫XM _x M _x /EJdx
AB b	0	-5/2Fx	0	0	0	0
BA b	0	5/2Fb-5/2Fx	0	0	0	0
BC b	-x/b	-5/2Fb+3/2Fx	5/2Fx-3/2Fx ² /b	x ² /b ²	3/4Fb ² /EJ	1/3Xb/EJ
CB b	1-x/b	Fb+3/2Fx	Fb+1/2Fx-3/2Fx ² /b	1-2x/b+x ² /b ²	-1/3Fb ² /EJ	Xb/EJ
CD b	-1	Fx-1/2qx ²	-Fx+1/2Fx ² /b	1	-1/3Fb ² /EJ	Xb/EJ
DC b	1	-1/2Fb+1/2qx ²	-1/2Fb+1/2Fx ² /b	1	-1/3Fb ² /EJ	Xb/EJ
DE b	-1+x/b	1/2Fb-3/2Fx	-1/2Fb+2Fx-3/2Fx ² /b	1-2x/b+x ² /b ²	0	1/3Xb/EJ
ED b	x/b	Fb-3/2Fx	Fx-3/2Fx ² /b	x ² /b ²	0	1/3Xb/EJ
EF √2b	0	√2/2Fx+1/2qx ²	0	0	0	0
FG b	0	-Fx	0	0	0	0
GF b	0	Fb-Fx	0	0	0	0
GA b	0	0	0	0	0	0
AG b	0	0	0	0	0	0
FB b	0	2Fb-2Fx	0	0	0	0
BF b	0	-2Fx	0	0	0	0
BE b	0	0	0	0	0	0
EB b	0	0	0	0	0	0
CD	elongazione asta N _{1,CD} ^ε _{CD} L _{CD}				-Fb ² /EJ	
	totali				-7/12Fb ² /EJ	5/3Xb/EJ
	iperstatica X=W _{CD}				7/20Fb	

Sviluppi di calcolo iperstatica

$$L_{BC}^{xx} = \int_0^b (x^2/b^2) 1/EJ dx = [1/3 x^3/b^2]_0^b 1/EJ$$

$$= (1/3 b) 1/EJ = 1/3 b/EJ$$

$$L_{CB}^{xx} = \int_0^b (1 - 2x/b + x^2/b^2) 1/EJ dx = [x - x^2/b + 1/3 x^3/b^2]_0^b 1/EJ$$

$$= (b - b + 1/3 b) 1/EJ = 1/3 b/EJ$$

$$L_{CD}^{xx} = \int_0^b (1) 1/EJ dx = [x]_0^b 1/EJ$$

$$= (b) 1/EJ = b/EJ$$

$$L_{DC}^{xx} = \int_0^b (1) 1/EJ dx = [x]_0^b 1/EJ$$

$$= (b) 1/EJ = b/EJ$$

$$L_{DE}^{xx} = \int_0^b (1 - 2x/b + x^2/b^2) 1/EJ dx = [x - x^2/b + 1/3 x^3/b^2]_0^b 1/EJ$$

$$= (b - b + 1/3 b) 1/EJ = 1/3 b/EJ$$

$$L_{ED}^{xx} = \int_0^b (x^2/b^2) 1/EJ dx = [1/3 x^3/b^2]_0^b 1/EJ$$

$$= (1/3 b) 1/EJ = 1/3 b/EJ$$

$$L_{BC}^{xo} = \int_0^b (5/2 x/b - 3/2 x^2/b^2) Fb 1/EJ dx = [5/4 x^2/b - 1/2 x^3/b^2]_0^b Fb 1/EJ$$

$$= (5/4 b - 1/2 b) Fb 1/EJ = 3/4 Fb^2/EJ$$

$$L_{CB}^{xo} = \int_0^b (1 + 1/2 x/b - 3/2 x^2/b^2) Fb 1/EJ dx = [x + 1/4 x^2/b - 1/2 x^3/b^2]_0^b Fb 1/EJ$$

$$= (b + 1/4 b - 1/2 b) Fb 1/EJ = 3/4 Fb^2/EJ$$

$$L_{CD}^{xo} = \int_0^b (-x/b + 1/2 x^2/b^2) Fb 1/EJ dx + 1 (-1) 1 Fb^2/EJ$$

$$= [-1/2 x^2/b + 1/6 x^3/b^2]_0^b Fb 1/EJ + 1 (-1) 1 Fb^2/EJ$$

$$= (-1/2 b + 1/6 b) Fb 1/EJ + 1 (-1) 1 Fb^2/EJ = -4/3 Fb^2/EJ$$

$$L_{DC}^{xo} = \int_0^b (-1/2 + 1/2 x^2/b^2) Fb 1/EJ dx + 1 (-1) 1 Fb^2/EJ$$

$$= [-1/2 x + 1/6 x^3/b^2]_0^b Fb 1/EJ + 1 (-1) 1 Fb^2/EJ$$

$$= (-1/2 b + 1/6 b) Fb 1/EJ + 1 (-1) 1 Fb^2/EJ = -4/3 Fb^2/EJ$$

$$L_{DE}^{xo} = \int_0^b (-1/2 + 2x/b - 3/2 x^2/b^2) Fb 1/EJ dx = [-1/2 x + x^2/b - 1/2 x^3/b^2]_0^b Fb 1/EJ$$

$$= (-1/2 b + b - 1/2 b) Fb 1/EJ = 0$$

$$L_{ED}^{xo} = \int_0^b (x/b - 3/2 x^2/b^2) Fb 1/EJ dx = [1/2 x^2/b - 1/2 x^3/b^2]_0^b Fb 1/EJ$$

$$= (1/2 b - 1/2 b) Fb 1/EJ = 0$$

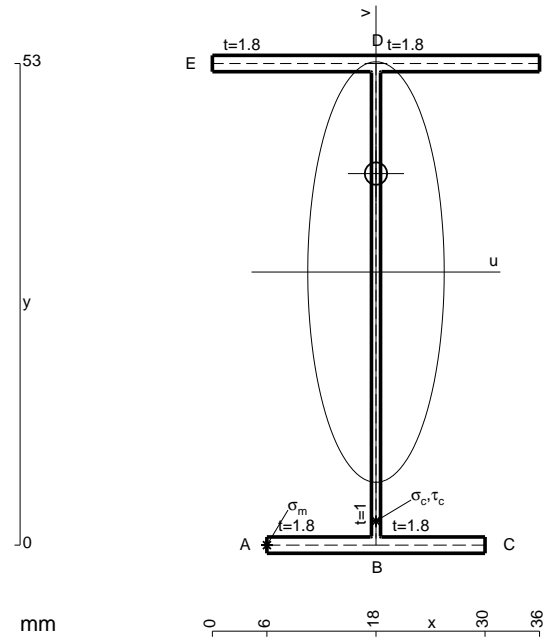

- A = 161. mm²
- J_u = 86214. mm⁴
- J_v = 9072. mm⁴
- J_t = 134.3 mm⁴
- y_o = 10.83 mm
- y_g = 30.06 mm
- N = -580. N
- T_y = -725. N
- M_x = -580000. Nmm
- x_m = 6. mm
- u_m = -12. mm
- v_m = -30.06 mm
- σ_m = N/A-Mv/J_u = -205.8 N/mm²
- x_c = 18. mm
- v_c = -30.06 mm
- σ_c = N/A-Mv/J_u = -205.8 N/mm²
- τ_c = TS/tJ_u = 10.92 N/mm²
- τ_g = TS/tJ_u = 10.92 N/mm²
- t_c = 290. mm
- σ_o = √σ²+3τ² = 206.7 N/mm²

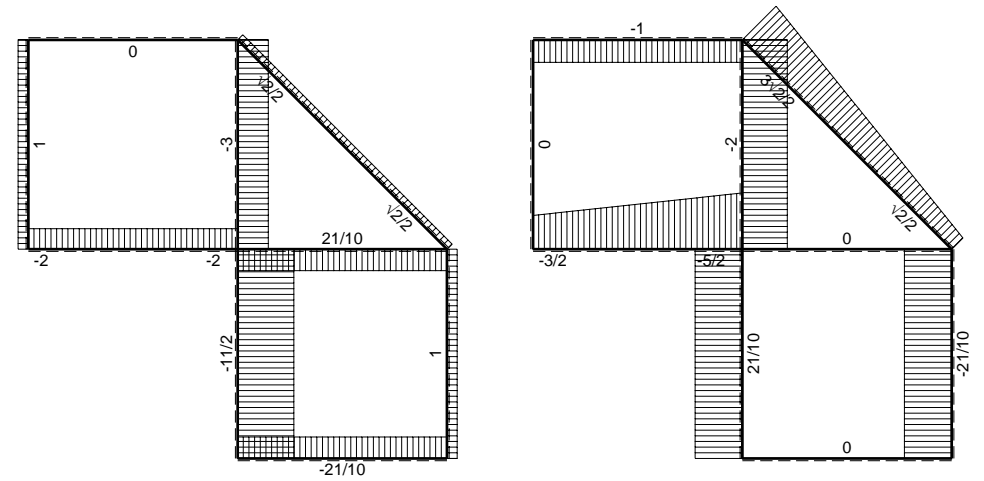
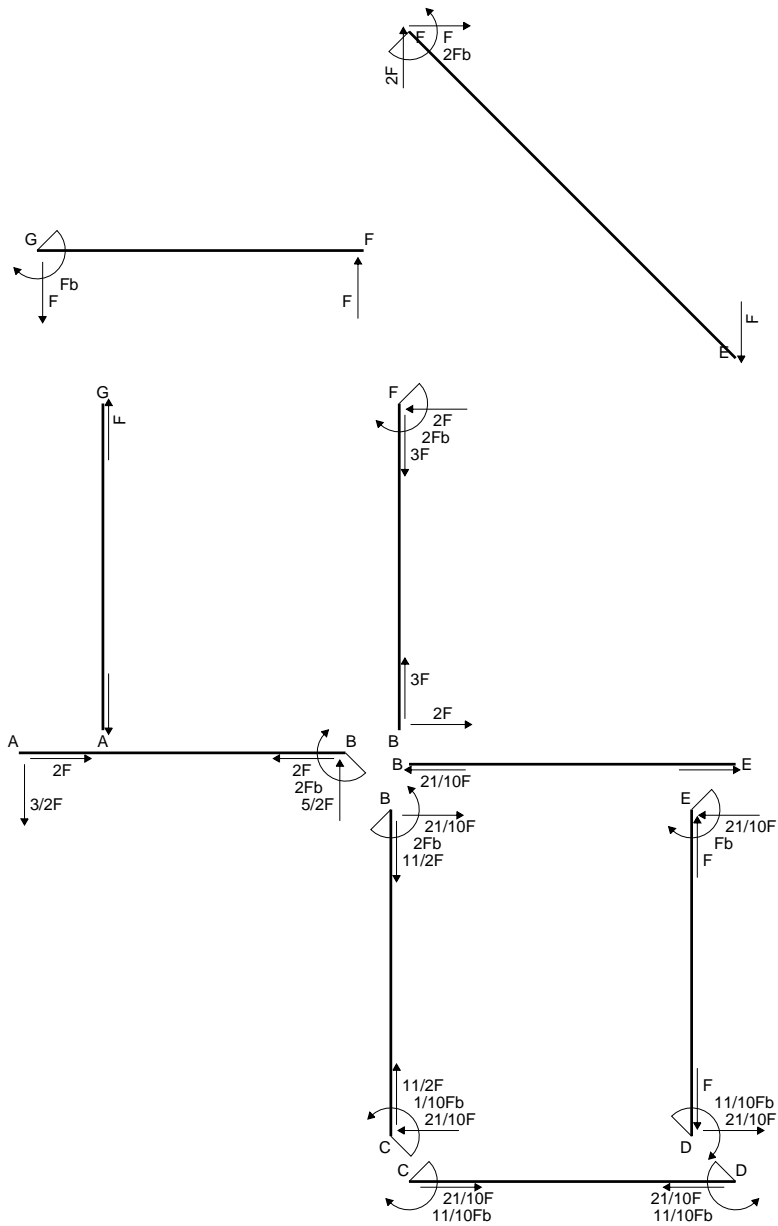

← ⊕ → F

↑ ⊕ ↓ F

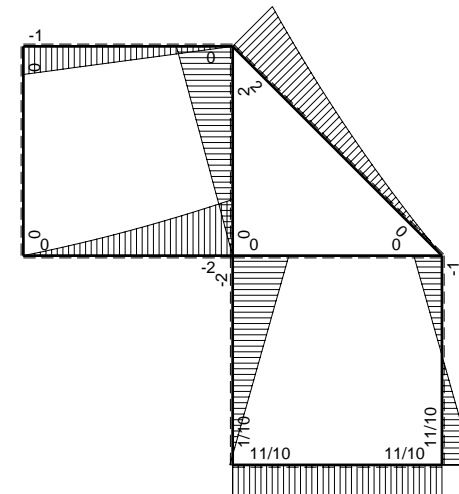

⊕ ⊖ F_b

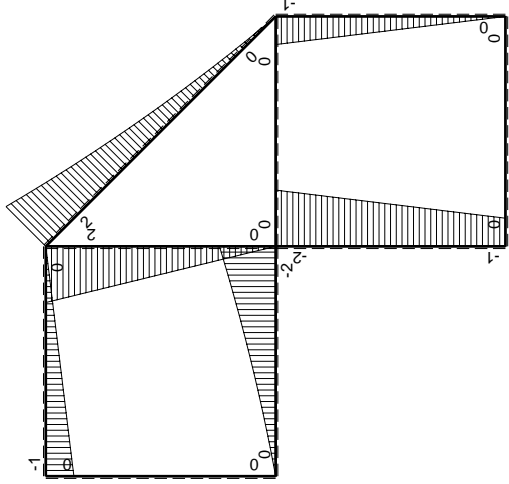
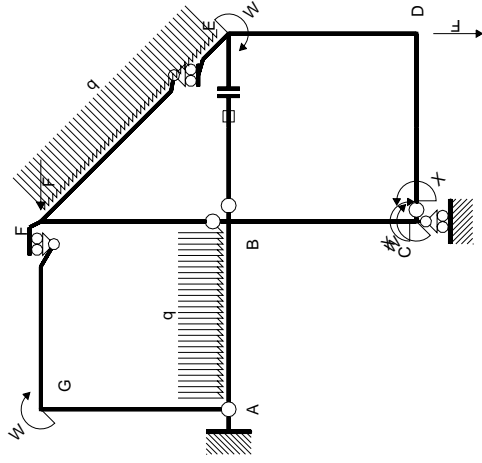

Schema di calcolo iperstatico

M_0 flessione da carichi assegnati

Quadro contributi PLV per iperstatica $X=W_{cd}$

\rightarrow	$M_x(x)$	$M_0(x)$	$M_x M_0$	$M_x M_x$	$\int M_x M_0 / EJ dx$	$\int M_x M_x / EJ dx$
AB b	0	$-3/2Fx - 1/2qx^2$	0	0	0	0
BA b	0	$2Fb - 5/2Fx + 1/2qx^2$	0	0	0	0
BC b	$-x/b$	$-2Fb + Fx$	$2Fx - Fx^2/b$	x^2/b^2	$2/3Fb^2/EJ$	$1/3Xb/EJ$
CB b	$1-x/b$	$Fb + Fx$	$Fb - Fx^2/b$	$1 - 2x/b + x^2/b^2$	0	0
CD b	-1	0	0	1	0	Xb/EJ
DC b	1	0	0	1	0	0
DE b	$-1+x/b$	-Fx	$Fx - Fx^2/b$	$1 - 2x/b + x^2/b^2$	$1/6Fb^2/EJ$	$1/3Xb/EJ$
ED b	x/b	$Fb - Fx$	$Fx - Fx^2/b$	x^2/b^2	0	0
EF $\sqrt{2}b$	0	$\sqrt{2}/2Fx + 1/2qx^2$	0	0	0	0
FG b	0	-Fx	0	0	0	0
GF b	0	$Fb - Fx$	0	0	0	0
GA b	0	0	0	0	0	0
AG b	0	0	0	0	0	0
FB b	0	$2Fb - 2Fx$	0	0	0	0
BF b	0	-2Fx	0	0	0	0
BE b	0	0	0	0	0	0
EB b	0	0	0	0	0	0
BE	elongazione asta $N_{1, BE} \epsilon_{BE} L_{BE}$				Fb^2/EJ	
	totali				$11/6Fb^2/EJ$	$5/3Xb/EJ$
	iperstatica $X=W_{cd}$				$-11/10Fb$	

Sviluppi di calcolo iperstatica

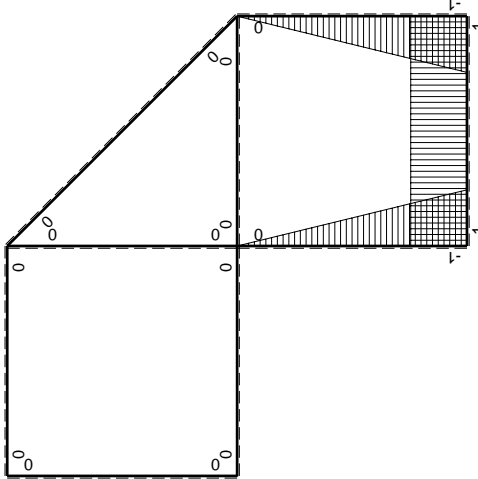

M_x flessione da iperstatica $X=1$

$$L_{BC}^{xx} = \int_0^b (x^2/b^2) 1/EJ dx = [1/3 x^3/b^2]_0^b 1/EJ$$

$$= (1/3 b) 1/EJ = 1/3 b/EJ$$

$$L_{CB}^{xx} = \int_0^b (1 - 2x/b + x^2/b^2) 1/EJ dx = [x - x^2/b + 1/3 x^3/b^2]_0^b 1/EJ$$

$$= (b - b + 1/3 b) 1/EJ = 1/3 b/EJ$$

$$L_{CD}^{xx} = \int_0^b (1) 1/EJ dx = [x]_0^b 1/EJ$$

$$= (b) 1/EJ = b/EJ$$

$$L_{DC}^{xx} = \int_0^b (1) 1/EJ dx = [x]_0^b 1/EJ$$

$$= (b) 1/EJ = b/EJ$$

$$L_{DE}^{xx} = \int_0^b (1 - 2x/b + x^2/b^2) 1/EJ dx = [x - x^2/b + 1/3 x^3/b^2]_0^b 1/EJ$$

$$= (b - b + 1/3 b) 1/EJ = 1/3 b/EJ$$

$$L_{ED}^{xx} = \int_0^b (x^2/b^2) 1/EJ dx = [1/3 x^3/b^2]_0^b 1/EJ$$

$$= (1/3 b) 1/EJ = 1/3 b/EJ$$

$$L_{BC}^{x_0} = \int_0^b (2x/b - x^2/b^2) Fb 1/EJ dx = [x^2/b - 1/3 x^3/b^2]_0^b Fb 1/EJ$$

$$= (b - 1/3 b) Fb 1/EJ = 2/3 Fb^2/EJ$$

$$L_{CB}^{x_0} = \int_0^b (1 - x^2/b^2) Fb 1/EJ dx = [x - 1/3 x^3/b^2]_0^b Fb 1/EJ$$

$$= (b - 1/3 b) Fb 1/EJ = 2/3 Fb^2/EJ$$

$$L_{DE}^{x_0} = \int_0^b (x/b - x^2/b^2) Fb 1/EJ dx = [1/2 x^2/b - 1/3 x^3/b^2]_0^b Fb 1/EJ$$

$$= (1/2 b - 1/3 b) Fb 1/EJ = 1/6 Fb^2/EJ$$

$$L_{ED}^{x_0} = \int_0^b (x/b - x^2/b^2) Fb 1/EJ dx = [1/2 x^2/b - 1/3 x^3/b^2]_0^b Fb 1/EJ$$

$$= (1/2 b - 1/3 b) Fb 1/EJ = 1/6 Fb^2/EJ$$

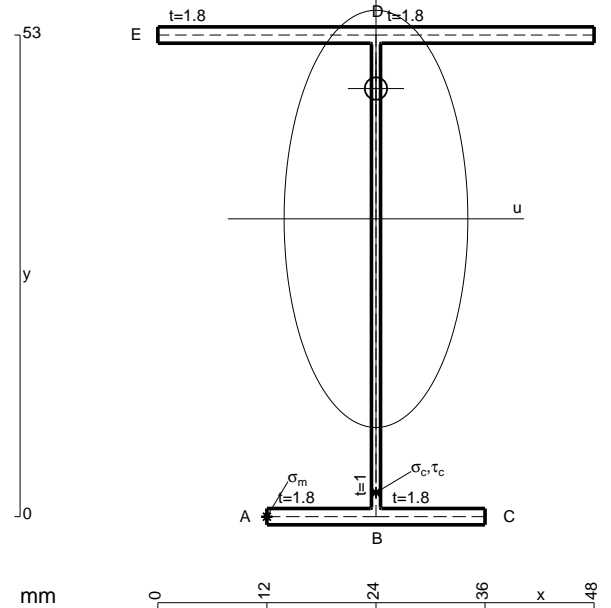

- A = 182.6 mm²
- J_u = 96241. mm⁴
- J_v = 18662. mm⁴
- J_t = 157.6 mm⁴
- y_o = 14.34 mm
- y_g = 32.77 mm
- N = -740. N
- T_y = -925. N
- M_x = -629000. Nmm
- x_m = 12. mm
- u_m = -12. mm
- v_m = -32.77 mm
- σ_m = N/A - Mv/J_u = -218.2 N/mm²
- x_c = 24. mm
- v_c = -32.77 mm
- σ_c = N/A - Mv/J_u = -218.2 N/mm²
- τ_c = TS^{*}/tJ_u = 13.61 N/mm²
- τ_g = TS^{*}/tJ_u = 13.61 N/mm²
- t_c = 370. mm
- σ_o = √σ² + 3τ² = 219.5 N/mm²

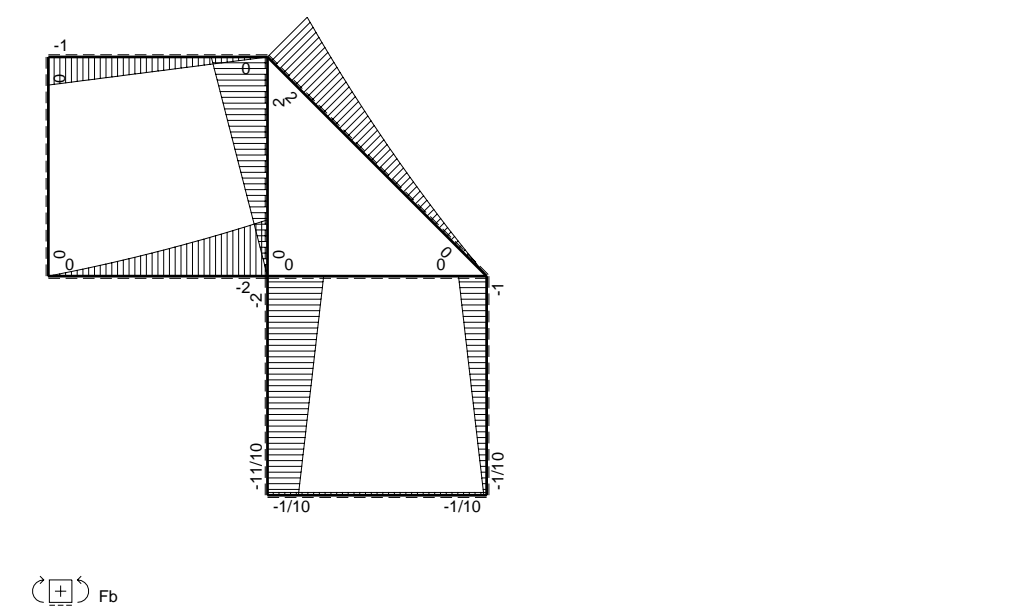
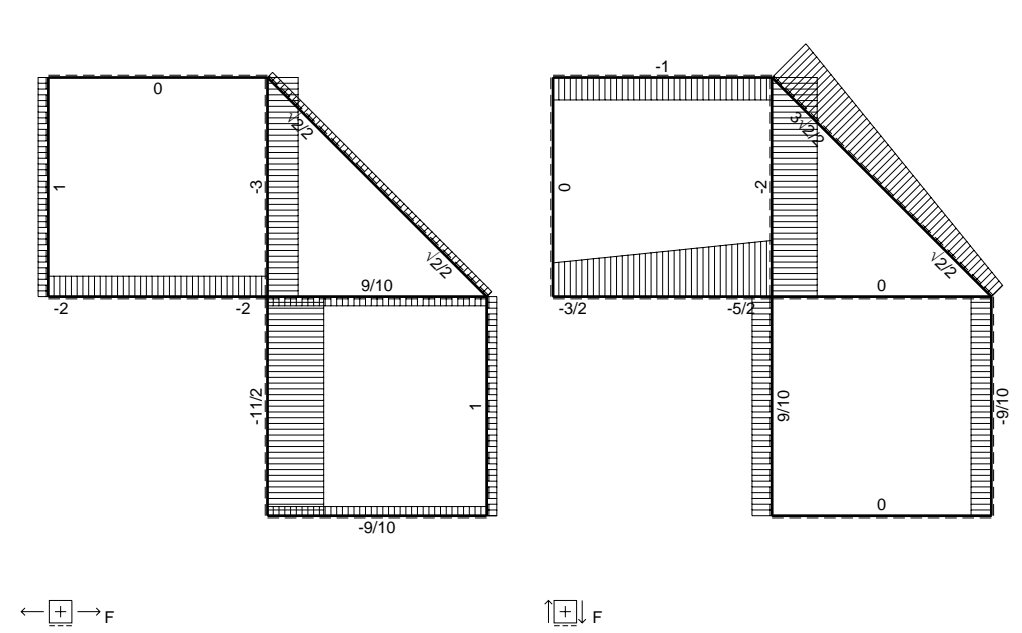
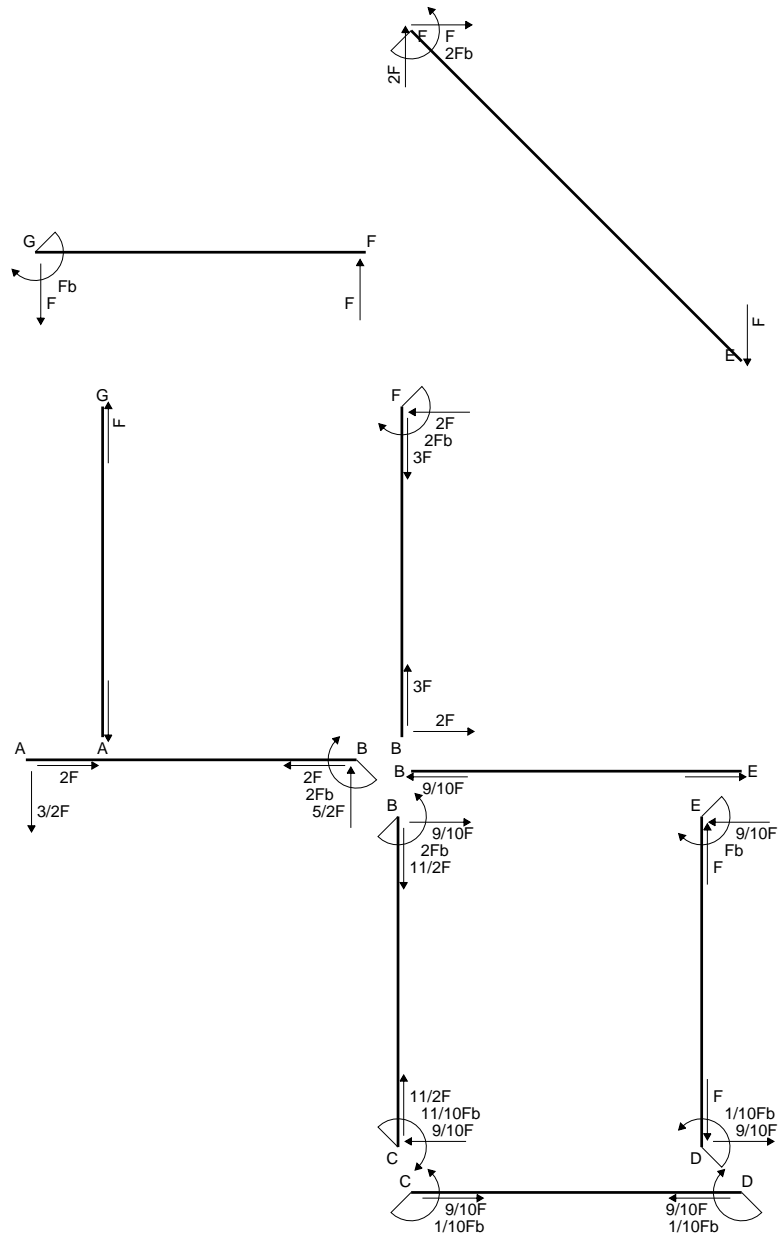

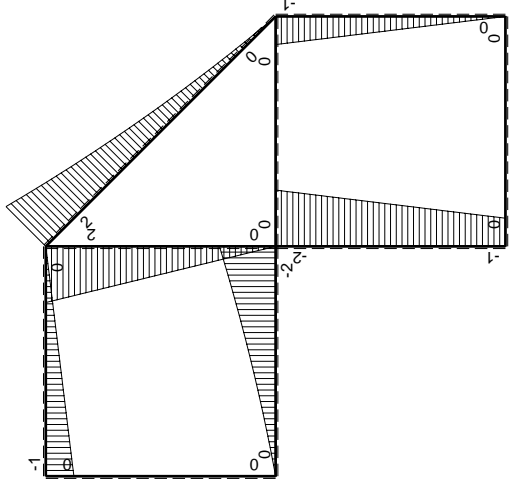
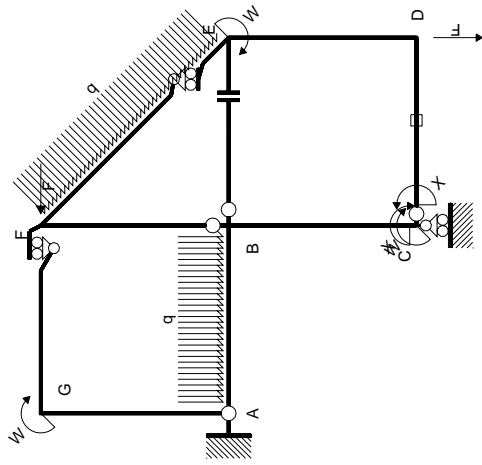

Schema di calcolo iperstatico

M_0 flessione da carichi assegnati

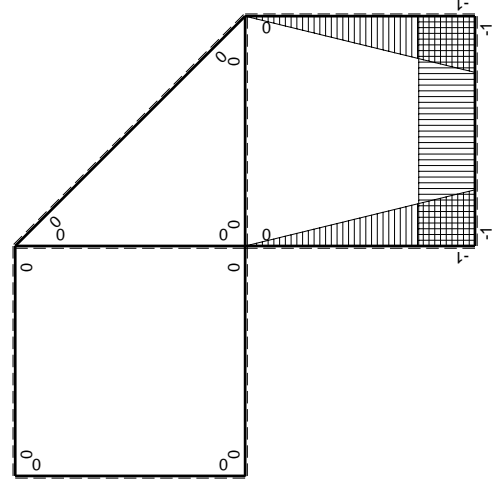

M_x flessione da iperstatica X=1

Quadro contribuiti PLV per iperstatica X=W_{CD}

→	$M_x(x)$	$M_0(x)$	$M_x M_0$	$M_x M_x$	$\int M_x M_0 / EJ dx$	$\int X M_x M_x / EJ dx$
AB b	0	$-3/2Fx - 1/2qx^2$	0	0	0	0
BA b	0	$2Fb - 5/2Fx + 1/2qx^2$	0	0	0	0
BC b	$-x/b$	$-2Fb + Fx$	$2Fx - Fx^2/b$	x^2/b^2	$2/3Fb^2/EJ$	$1/3Xb/EJ$
CB b	$1-x/b$	$Fb + Fx$	$Fb - Fx^2/b$	$1 - 2x/b + x^2/b^2$	0	0
CD b	-1	0	0	1	0	Xb/EJ
DC b	1	0	0	1	0	0
DE b	$-1+x/b$	$-Fx$	$Fx - Fx^2/b$	$1 - 2x/b + x^2/b^2$	$1/6Fb^2/EJ$	$1/3Xb/EJ$
ED b	x/b	$Fb - Fx$	$Fx - Fx^2/b$	x^2/b^2	0	0
EF $\sqrt{2}b$	0	$\sqrt{2}/2Fx + 1/2qx^2$	0	0	0	0
FG b	0	$-Fx$	0	0	0	0
GF b	0	$Fb - Fx$	0	0	0	0
GA b	0	0	0	0	0	0
AG b	0	0	0	0	0	0
FB b	0	$2Fb - 2Fx$	0	0	0	0
BF b	0	$-2Fx$	0	0	0	0
BE b	0	0	0	0	0	0
EB b	0	0	0	0	0	0
CD	elongazione asta $N_{1,cd} \epsilon_{cd} L_{cd}$				$-Fb^2/EJ$	
	totali				$-1/6Fb^2/EJ$	$5/3Xb/EJ$
	iperstatica X=W _{CD}				$1/10Fb$	

Sviluppi di calcolo iperstatica

$$L_{BC}^{xx} = \int_0^b (x^2/b^2) 1/EJ dx = [1/3 x^3/b^2]_0^b 1/EJ$$

$$= (1/3 b) 1/EJ = 1/3 b/EJ$$

$$L_{CB}^{xx} = \int_0^b (1 - 2x/b + x^2/b^2) 1/EJ dx = [x - x^2/b + 1/3 x^3/b^2]_0^b 1/EJ$$

$$= (b - b + 1/3 b) 1/EJ = 1/3 b/EJ$$

$$L_{CD}^{xx} = \int_0^b (1) 1/EJ dx = [x]_0^b 1/EJ$$

$$= (b) 1/EJ = b/EJ$$

$$L_{DC}^{xx} = \int_0^b (1) 1/EJ dx = [x]_0^b 1/EJ$$

$$= (b) 1/EJ = b/EJ$$

$$L_{DE}^{xx} = \int_0^b (1 - 2x/b + x^2/b^2) 1/EJ dx = [x - x^2/b + 1/3 x^3/b^2]_0^b 1/EJ$$

$$= (b - b + 1/3 b) 1/EJ = 1/3 b/EJ$$

$$L_{ED}^{xx} = \int_0^b (x^2/b^2) 1/EJ dx = [1/3 x^3/b^2]_0^b 1/EJ$$

$$= (1/3 b) 1/EJ = 1/3 b/EJ$$

$$L_{BC}^{xo} = \int_0^b (2x/b - x^2/b^2) Fb 1/EJ dx = [x^2/b - 1/3 x^3/b^2]_0^b Fb 1/EJ$$

$$= (b - 1/3 b) Fb 1/EJ = 2/3 Fb^2/EJ$$

$$L_{CB}^{xo} = \int_0^b (1 - x^2/b^2) Fb 1/EJ dx = [x - 1/3 x^3/b^2]_0^b Fb 1/EJ$$

$$= (b - 1/3 b) Fb 1/EJ = 2/3 Fb^2/EJ$$

$$L_{DE}^{xo} = \int_0^b (x/b - x^2/b^2) Fb 1/EJ dx = [1/2 x^2/b - 1/3 x^3/b^2]_0^b Fb 1/EJ$$

$$= (1/2 b - 1/3 b) Fb 1/EJ = 1/6 Fb^2/EJ$$

$$L_{ED}^{xo} = \int_0^b (x/b - x^2/b^2) Fb 1/EJ dx = [1/2 x^2/b - 1/3 x^3/b^2]_0^b Fb 1/EJ$$

$$= (1/2 b - 1/3 b) Fb 1/EJ = 1/6 Fb^2/EJ$$

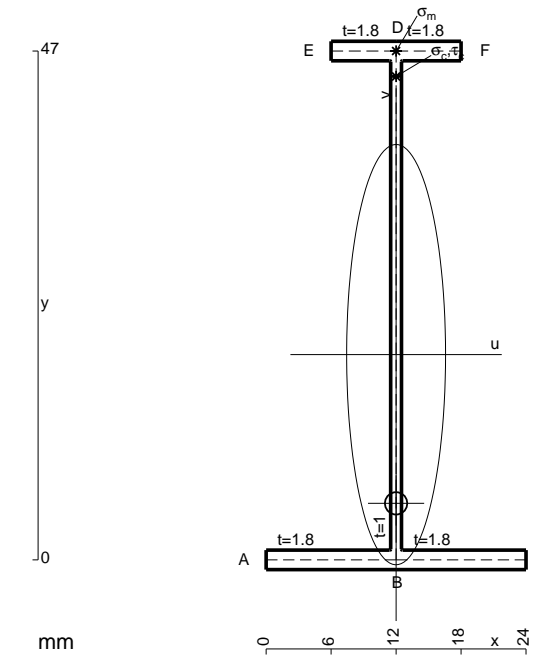

- A = 111.8 mm²
- J_u = 42133. mm⁴
- J_v = 2333. mm⁴
- J_t = 85.65 mm⁴
- y_o = -13.74 mm
- y_g = 18.96 mm
- N = -440. N
- T_y = -550. N
- M_x = -347600. Nmm
- x_m = 12. mm
- y_m = 47. mm
- v_m = 28.04 mm
- σ_m = N/A-Mv/J_u = 227.4 N/mm²
- y_c = 2. mm
- u_c = -12. mm
- v_c = -16.96 mm
- σ_c = N/A-Mv/J_u = 227.4 N/mm²
- τ_c = TS¹/tJ_u = 7.906 N/mm²
- τ_g = TS¹/tJ_u = 7.906 N/mm²
- t_c = 220. mm
- σ_o = √σ²+3τ² = 227.8 N/mm²

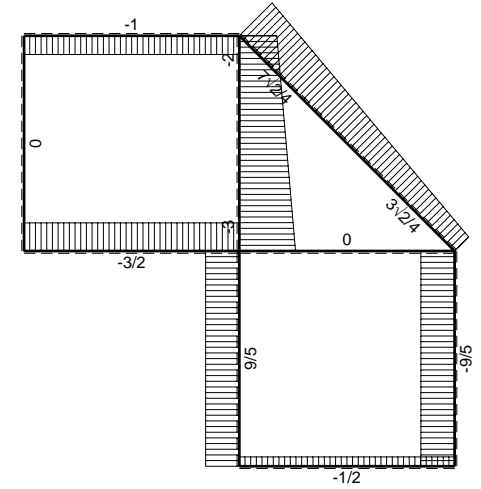
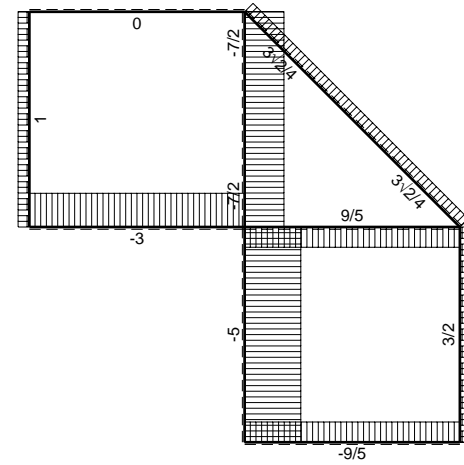
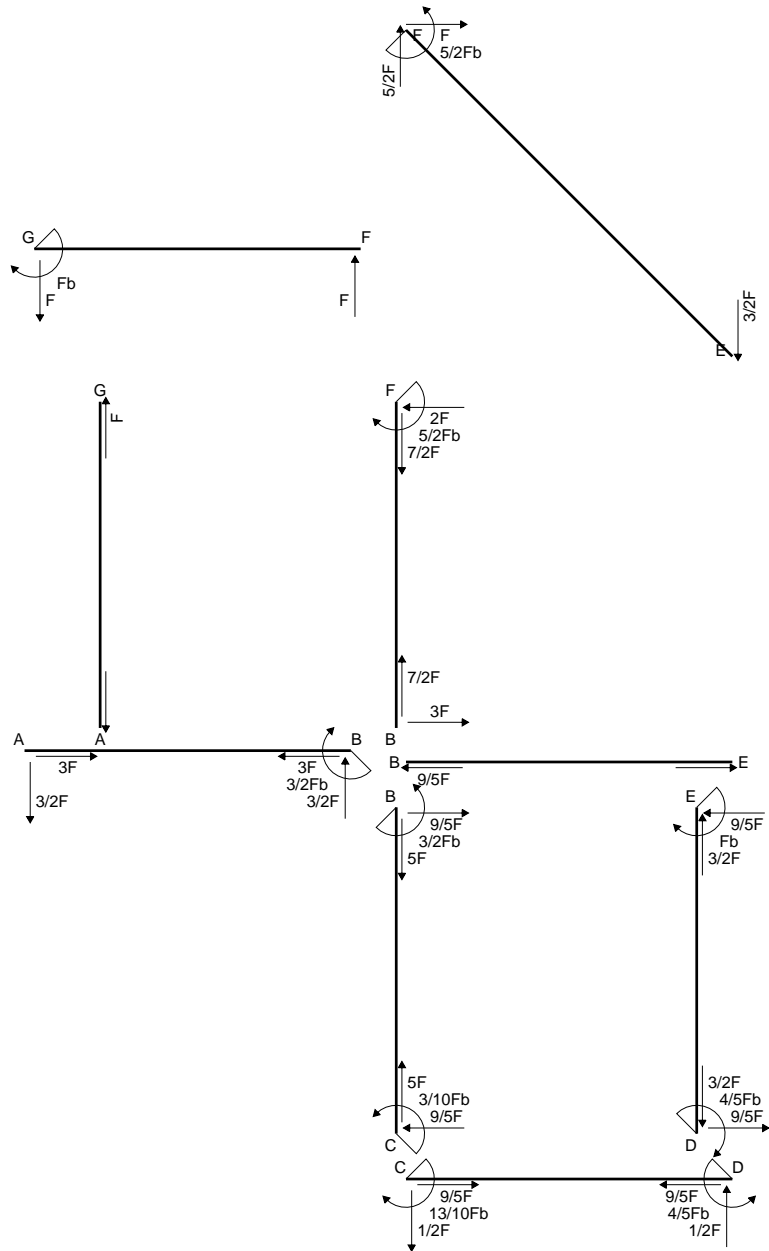

← ⊕ → F

↑ ⊕ ↓ F

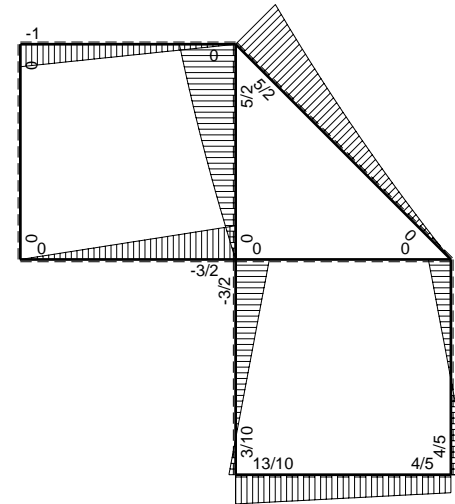

⊕ ⊖ F_b

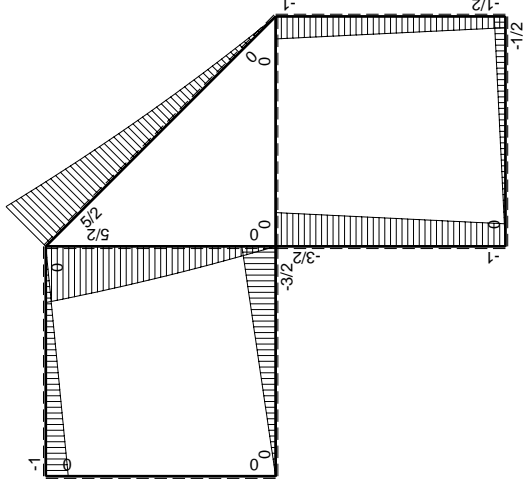
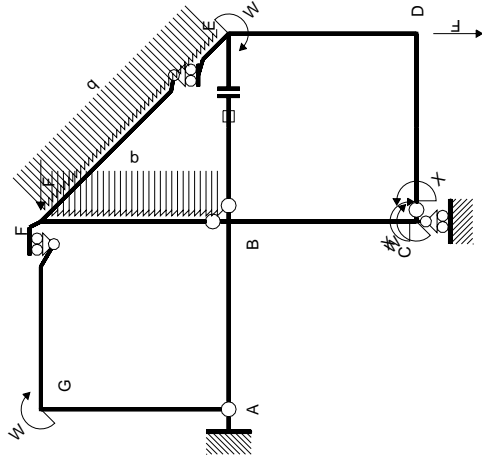

Schema di calcolo iperstatico

M_0 flessione da carichi assegnati

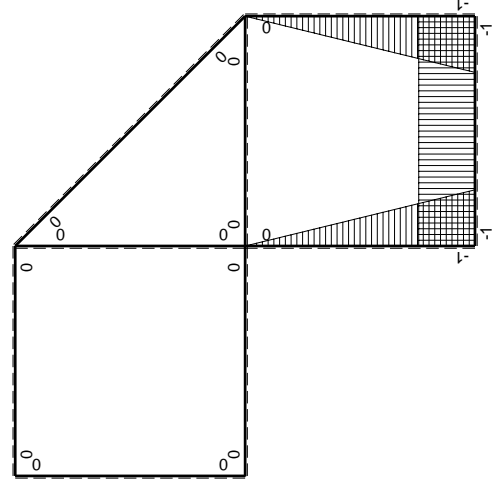

M_x flessione da iperstatica $X=1$

Quadro contribuiti PLV per iperstatica $X=W_{cd}$

\rightarrow	$M_x(x)$	$M_0(x)$	$M_x M_0$	$M_x M_x$	$\int M_x M_0 / EJ dx$	$\int X M_x M_x / EJ dx$
AB b	0	-3/2Fx	0	0	0	0
BA b	0	3/2Fb-3/2Fx	0	0	0	0
BC b	-x/b	-3/2Fb+1/2Fx	3/2Fx-1/2Fx ² /b	x ² /b ²	7/12Fb ² /EJ	1/3Xb/EJ
CB b	1-x/b	Fb+1/2Fx	Fb-1/2Fx-1/2Fx ² /b	1-2x/b+x ² /b ²	1/4Fb ² /EJ	Xb/EJ
CD b	-1	-1/2Fx	1/2Fx	1	1/4Fb ² /EJ	Xb/EJ
DC b	1	1/2Fb-1/2Fx	1/2Fb-1/2Fx	1	1/4Fb ² /EJ	Xb/EJ
DE b	-1+x/b	-1/2Fb-1/2Fx	1/2Fb-1/2Fx ² /b	1-2x/b+x ² /b ²	1/3Fb ² /EJ	1/3Xb/EJ
ED b	x/b	Fb-1/2Fx	Fx-1/2Fx ² /b	x ² /b ²	1/3Fb ² /EJ	1/3Xb/EJ
EF $\sqrt{2}b$	0	3\sqrt{2}/4Fx+1/2qx ²	0	0	0	0
FG b	0	-Fx	0	0	0	0
GF b	0	Fb-Fx	0	0	0	0
GA b	0	0	0	0	0	0
AG b	0	0	0	0	0	0
FB b	0	5/2Fb-2Fx-1/2qx ²	0	0	0	0
BF b	0	-3Fx+1/2qx ²	0	0	0	0
BE b	0	0	0	0	0	0
EB b	0	0	0	0	0	0
BE	elongazione asta $N_{1, BE}^E - L_{BE}^E$				Fb ² /EJ	
	totali				13/6Fb ² /EJ	5/3Xb/EJ
	iperstatica $X=W_{cd}$				-13/10Fb	

Sviluppi di calcolo iperstatica

$$L_{BC}^{xx} = \int_0^b (x^2/b^2) 1/EJ dx = [1/3 x^3/b^2]_0^b 1/EJ$$

$$= (1/3 b) 1/EJ = 1/3 b/EJ$$

$$L_{CB}^{xx} = \int_0^b (1 - 2x/b + x^2/b^2) 1/EJ dx = [x - x^2/b + 1/3 x^3/b^2]_0^b 1/EJ$$

$$= (b - b + 1/3 b) 1/EJ = 1/3 b/EJ$$

$$L_{CD}^{xx} = \int_0^b (1) 1/EJ dx = [x]_0^b 1/EJ$$

$$= (b) 1/EJ = b/EJ$$

$$L_{DC}^{xx} = \int_0^b (1) 1/EJ dx = [x]_0^b 1/EJ$$

$$= (b) 1/EJ = b/EJ$$

$$L_{DE}^{xx} = \int_0^b (1 - 2x/b + x^2/b^2) 1/EJ dx = [x - x^2/b + 1/3 x^3/b^2]_0^b 1/EJ$$

$$= (b - b + 1/3 b) 1/EJ = 1/3 b/EJ$$

$$L_{ED}^{xx} = \int_0^b (x^2/b^2) 1/EJ dx = [1/3 x^3/b^2]_0^b 1/EJ$$

$$= (1/3 b) 1/EJ = 1/3 b/EJ$$

$$L_{BC}^{x_0} = \int_0^b (3/2 x/b - 1/2 x^2/b^2) Fb 1/EJ dx = [3/4 x^2/b - 1/6 x^3/b^2]_0^b Fb 1/EJ$$

$$= (3/4 b - 1/6 b) Fb 1/EJ = 7/12 Fb^2/EJ$$

$$L_{CB}^{x_0} = \int_0^b (1 - 1/2 x/b - 1/2 x^2/b^2) Fb 1/EJ dx = [x - 1/4 x^2/b - 1/6 x^3/b^2]_0^b Fb 1/EJ$$

$$= (b - 1/4 b - 1/6 b) Fb 1/EJ = 7/12 Fb^2/EJ$$

$$L_{CD}^{x_0} = \int_0^b (1/2 x/b) Fb 1/EJ dx = [1/4 x^2/b]_0^b Fb 1/EJ$$

$$= (1/4 b) Fb 1/EJ = 1/4 Fb^2/EJ$$

$$L_{DC}^{x_0} = \int_0^b (1/2 - 1/2 x/b) Fb 1/EJ dx = [1/2 x - 1/4 x^2/b]_0^b Fb 1/EJ$$

$$= (1/2 b - 1/4 b) Fb 1/EJ = 1/4 Fb^2/EJ$$

$$L_{DE}^{x_0} = \int_0^b (1/2 - 1/2 x^2/b^2) Fb 1/EJ dx = [1/2 x - 1/6 x^3/b^2]_0^b Fb 1/EJ$$

$$= (1/2 b - 1/6 b) Fb 1/EJ = 1/3 Fb^2/EJ$$

$$L_{ED}^{x_0} = \int_0^b (x/b - 1/2 x^2/b^2) Fb 1/EJ dx = [1/2 x^2/b - 1/6 x^3/b^2]_0^b Fb 1/EJ$$

$$= (1/2 b - 1/6 b) Fb 1/EJ = 1/3 Fb^2/EJ$$

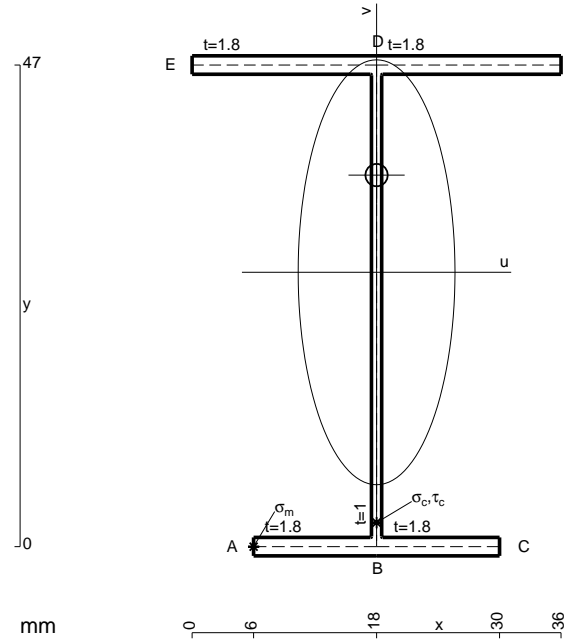

$$A = 155. \text{ mm}^2$$

$$J_u = 66633. \text{ mm}^4$$

$$J_v = 9072. \text{ mm}^4$$

$$J_t = 132.3 \text{ mm}^4$$

$$y_o = 9.482 \text{ mm}$$

$$y_g = 26.77 \text{ mm}$$

$$N = 297. \text{ N}$$

$$T_y = 693. \text{ N}$$

$$M_x = 581000. \text{ Nmm}$$

$$x_m = 6. \text{ mm}$$

$$u_m = -12. \text{ mm}$$

$$v_m = -26.77 \text{ mm}$$

$$\sigma_m = N/A - Mv/J_u = 235.4 \text{ N/mm}^2$$

$$x_c = 18. \text{ mm}$$

$$v_c = -26.77 \text{ mm}$$

$$\sigma_c = N/A - Mv/J_u = 235.4 \text{ N/mm}^2$$

$$\tau_c = TS'/tJ_u = 12.03 \text{ N/mm}^2$$

$$\tau_g = TS'/tJ_u = 12.03 \text{ N/mm}^2$$

$$t_c = 280. \text{ mm}$$

$$\sigma_o = \sqrt{\sigma^2 + 3\tau^2} = 236.3 \text{ N/mm}^2$$

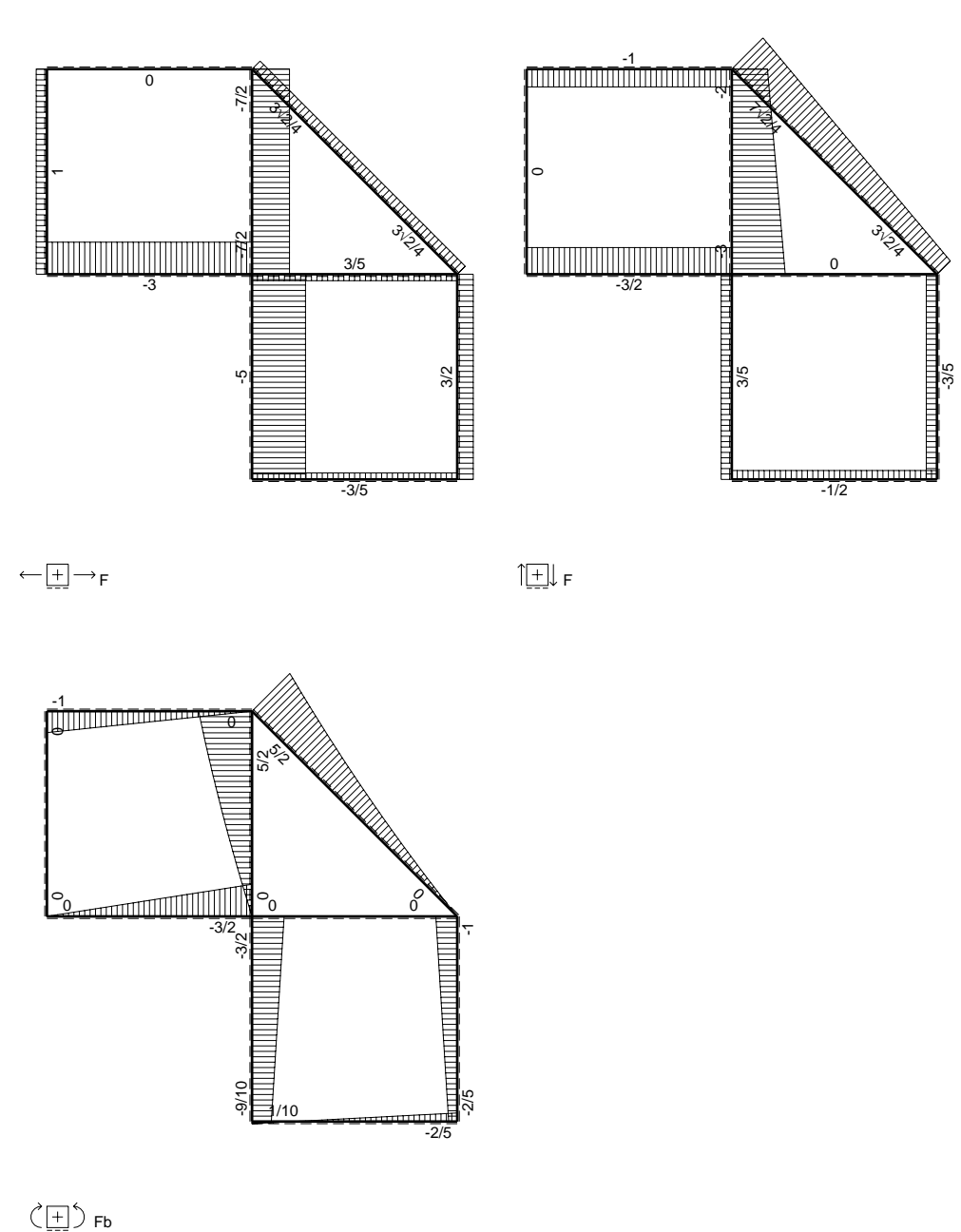
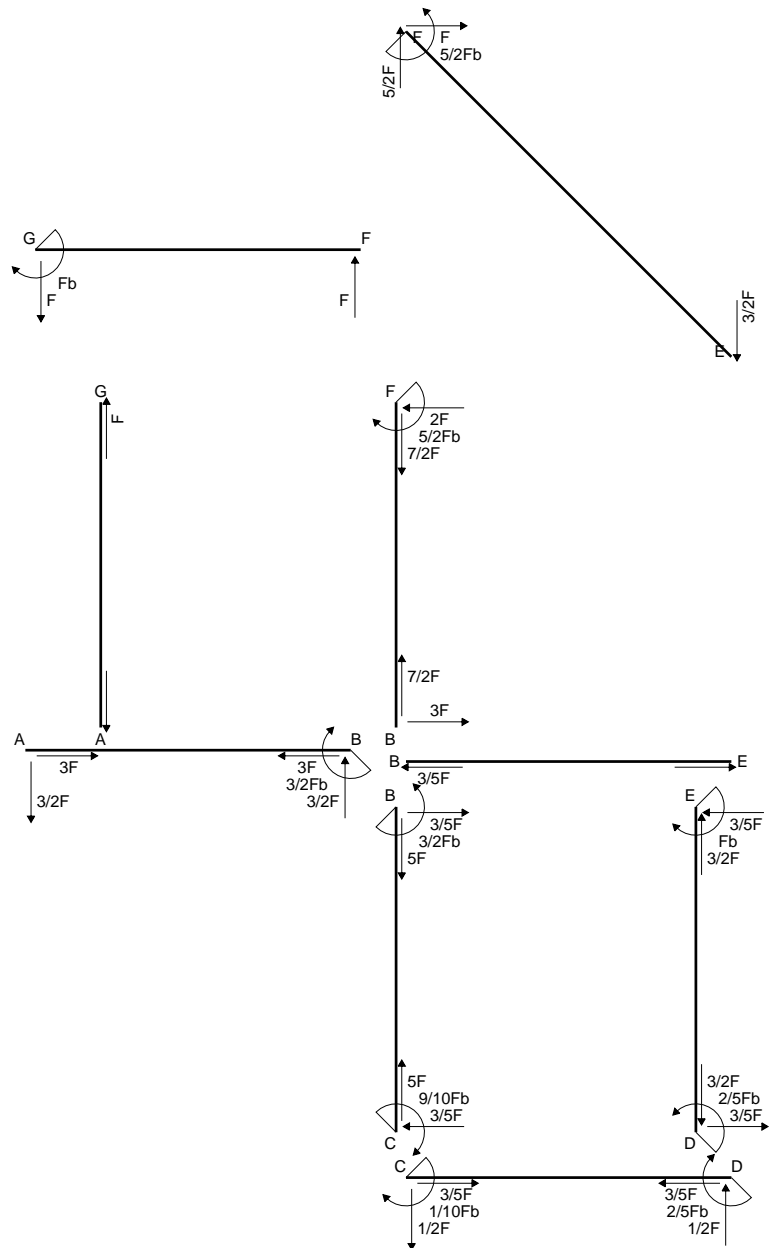

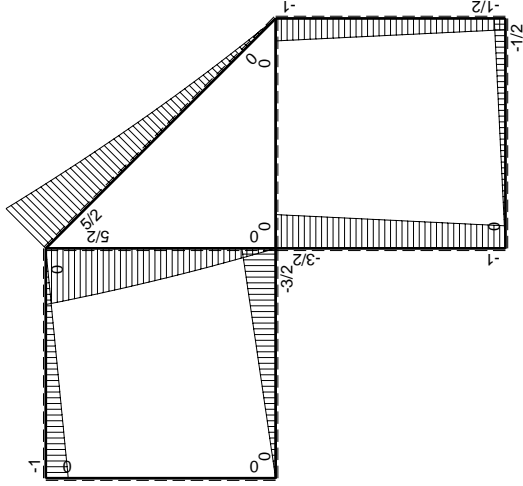
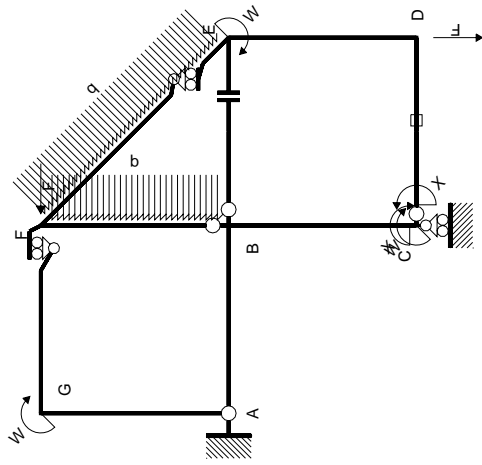

Schema di calcolo iperstatico

M_0 flessione da carichi assegnati

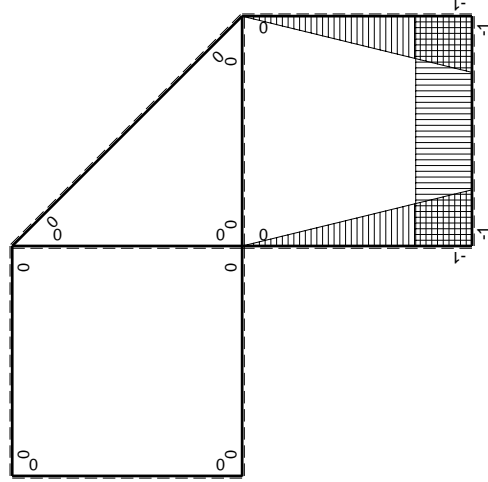

M_x flessione da iperstatica $X=1$

Quadro contribuiti PLV per iperstatica $X=W_{cd}$

\rightarrow	$M_x(x)$	$M_0(x)$	$M_x M_0$	$M_x M_x$	$\int M_x M_0 / EJ dx$	$\int X M_x M_x / EJ dx$
AB b	0	-3/2Fx	0	0	0	0
BA b	0	3/2Fb-3/2Fx	0	0	0	0
BC b	-x/b	-3/2Fb+1/2Fx	3/2Fx-1/2Fx ² /b	x ² /b ²	7/12Fb ² /EJ	1/3Xb/EJ
CB b	1-x/b	Fb+1/2Fx	Fb-1/2Fx-1/2Fx ² /b	1-2x/b+x ² /b ²	1/4Fb ² /EJ	Xb/EJ
CD b	-1	-1/2Fx	1/2Fx	1	1/4Fb ² /EJ	Xb/EJ
DC b	1	1/2Fb-1/2Fx	1/2Fb-1/2Fx	1	1/4Fb ² /EJ	Xb/EJ
DE b	-1+x/b	-1/2Fb-1/2Fx	1/2Fb-1/2Fx ² /b	1-2x/b+x ² /b ²	1/3Fb ² /EJ	1/3Xb/EJ
ED b	x/b	Fb-1/2Fx	Fx-1/2Fx ² /b	x ² /b ²	1/3Fb ² /EJ	1/3Xb/EJ
EF $\sqrt{2}b$	0	3\sqrt{2}/4Fx+1/2qx ²	0	0	0	0
FG b	0	-Fx	0	0	0	0
GF b	0	Fb-Fx	0	0	0	0
GA b	0	0	0	0	0	0
AG b	0	0	0	0	0	0
FB b	0	5/2Fb-2Fx-1/2qx ²	0	0	0	0
BF b	0	-3Fx+1/2qx ²	0	0	0	0
BE b	0	0	0	0	0	0
EB b	0	0	0	0	0	0
CD	elongazione asta $N_{1,cd} \epsilon_{cd} L_{cd}$			0	-Fb ² /EJ	
	totali				1/6Fb ² /EJ	5/3Xb/EJ
	iperstatica $X=W_{cd}$				-1/10Fb	

Sviluppi di calcolo iperstatica

$$L_{BC}^{xx} = \int_0^b (x^2/b^2) 1/EJ dx = [1/3 x^3/b^2]_0^b 1/EJ$$

$$= (1/3 b) 1/EJ = 1/3 b/EJ$$

$$L_{CB}^{xx} = \int_0^b (1 - 2x/b + x^2/b^2) 1/EJ dx = [x - x^2/b + 1/3 x^3/b^2]_0^b 1/EJ$$

$$= (b - b + 1/3 b) 1/EJ = 1/3 b/EJ$$

$$L_{CD}^{xx} = \int_0^b (1) 1/EJ dx = [x]_0^b 1/EJ$$

$$= (b) 1/EJ = b/EJ$$

$$L_{DC}^{xx} = \int_0^b (1) 1/EJ dx = [x]_0^b 1/EJ$$

$$= (b) 1/EJ = b/EJ$$

$$L_{DE}^{xx} = \int_0^b (1 - 2x/b + x^2/b^2) 1/EJ dx = [x - x^2/b + 1/3 x^3/b^2]_0^b 1/EJ$$

$$= (b - b + 1/3 b) 1/EJ = 1/3 b/EJ$$

$$L_{ED}^{xx} = \int_0^b (x^2/b^2) 1/EJ dx = [1/3 x^3/b^2]_0^b 1/EJ$$

$$= (1/3 b) 1/EJ = 1/3 b/EJ$$

$$L_{BC}^{x_0} = \int_0^b (3/2 x/b - 1/2 x^2/b^2) Fb 1/EJ dx = [3/4 x^2/b - 1/6 x^3/b^2]_0^b Fb 1/EJ$$

$$= (3/4 b - 1/6 b) Fb 1/EJ = 7/12 Fb^2/EJ$$

$$L_{CB}^{x_0} = \int_0^b (1 - 1/2 x/b - 1/2 x^2/b^2) Fb 1/EJ dx = [x - 1/4 x^2/b - 1/6 x^3/b^2]_0^b Fb 1/EJ$$

$$= (b - 1/4 b - 1/6 b) Fb 1/EJ = 7/12 Fb^2/EJ$$

$$L_{CD}^{x_0} = \int_0^b (1/2 x/b) Fb 1/EJ dx + 1 (-1) 1 Fb^2/EJ = [1/4 x^2/b]_0^b Fb 1/EJ + 1 (-1) 1 Fb^2/EJ$$

$$= (1/4 b) Fb 1/EJ + 1 (-1) 1 Fb^2/EJ = -3/4 Fb^2/EJ$$

$$L_{DC}^{x_0} = \int_0^b (1/2 - 1/2 x/b) Fb 1/EJ dx + 1 (-1) 1 Fb^2/EJ = [1/2 x - 1/4 x^2/b]_0^b Fb 1/EJ + 1 (-1) 1 Fb^2/EJ$$

$$= (1/2 b - 1/4 b) Fb 1/EJ + 1 (-1) 1 Fb^2/EJ = -3/4 Fb^2/EJ$$

$$L_{DE}^{x_0} = \int_0^b (1/2 - 1/2 x^2/b^2) Fb 1/EJ dx = [1/2 x - 1/6 x^3/b^2]_0^b Fb 1/EJ$$

$$= (1/2 b - 1/6 b) Fb 1/EJ = 1/3 Fb^2/EJ$$

$$L_{ED}^{x_0} = \int_0^b (x/b - 1/2 x^2/b^2) Fb 1/EJ dx = [1/2 x^2/b - 1/6 x^3/b^2]_0^b Fb 1/EJ$$

$$= (1/2 b - 1/6 b) Fb 1/EJ = 1/3 Fb^2/EJ$$

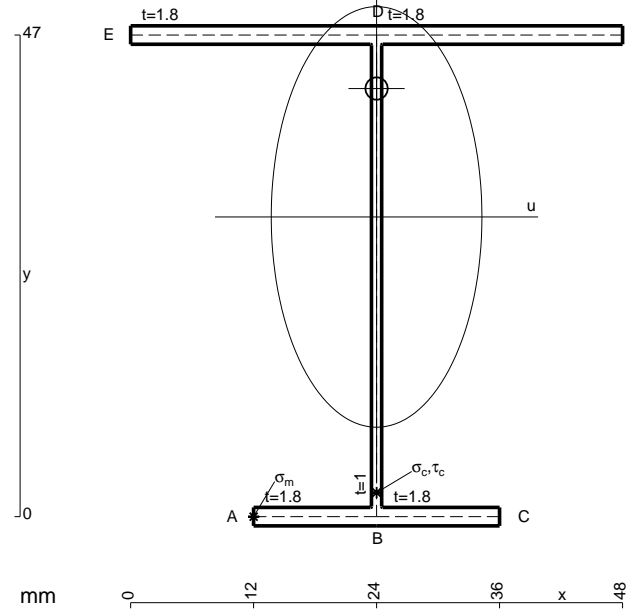

- A = 176.6 mm²
- J_u = 74388. mm⁴
- J_v = 18662. mm⁴
- J_t = 155.6 mm⁴
- y_o = 12.53 mm
- y_g = 29.25 mm
- N = 477.3 N
- T_y = 1114. N
- M_x = 495000. Nmm
- x_m = 12. mm
- u_m = -12. mm
- v_m = -29.25 mm
- σ_m = N/A-Mv/J_u = 197.3 N/mm²
- x_c = 24. mm
- v_c = -29.25 mm
- σ_c = N/A-Mv/J_u = 197.3 N/mm²
- τ_c = TS_t/tJ_u = 18.92 N/mm²
- τ_g = TS_t/tJ_u = 18.92 N/mm²
- t_c = 450. mm
- σ_o = √σ²+3τ² = 200. N/mm²

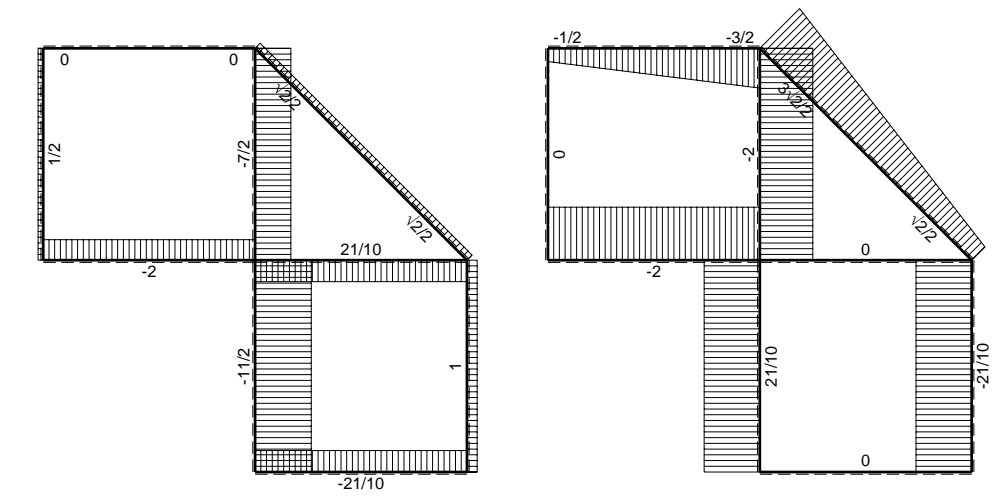
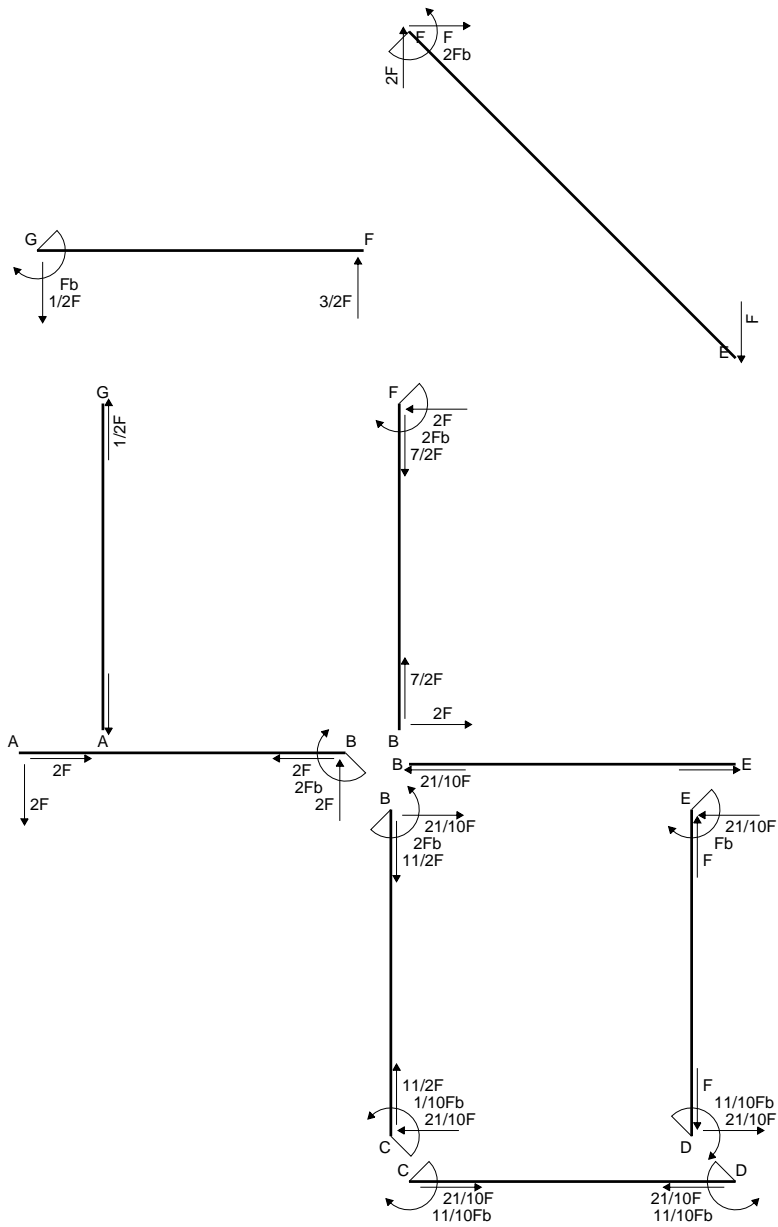

← ⊕ → F

↑ ⊕ ↓ F

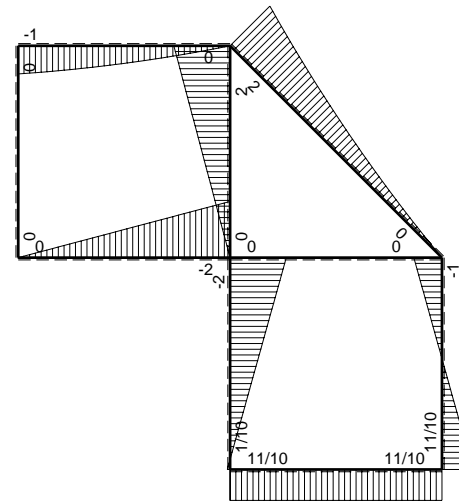

⊕ ⊖ F_b

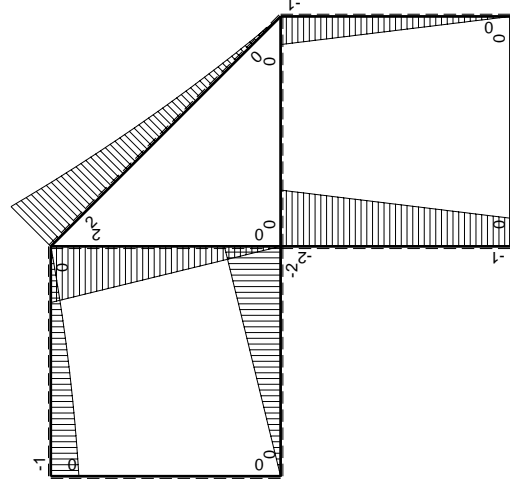
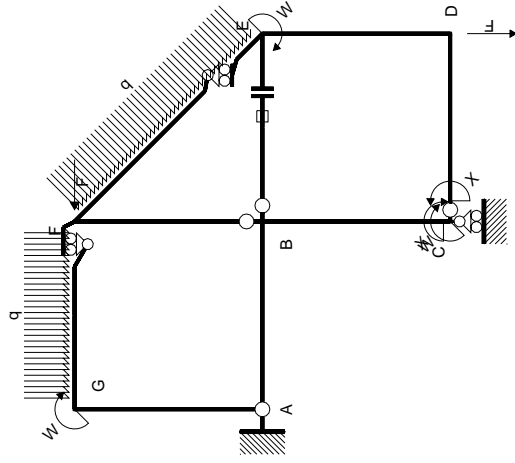

Schema di calcolo iperstatico

M_0 flessione da carichi assegnati

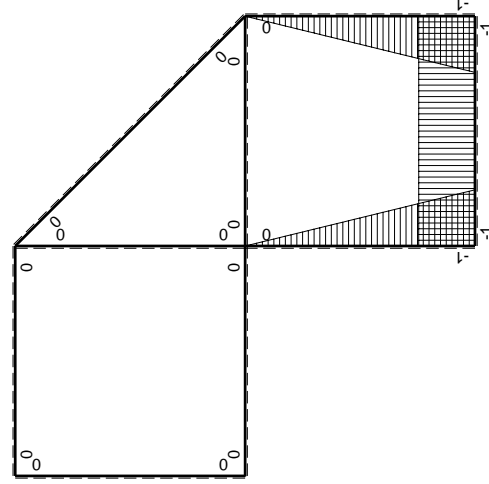

M_x flessione da iperstatica X=1

Quadro contributi PLV per iperstatica X=W_{cd}

→	$M_x(x)$	$M_0(x)$	$M_x M_0$	$M_x M_x$	$\int M_x M_0 / E J dx$	$\int X M_x M_x / E J dx$
AB b	0	-2Fx	0	0	0	0
BA b	0	2Fb-2Fx	0	0	0	0
BC b	-x/b	-2Fb+Fx	2Fx-Fx ² /b	x ² /b ²	2/3Fb ² /EJ	1/3Xb/EJ
CB b	1-x/b	Fb+Fx	Fb-Fx ² /b	1-2x/b+x ² /b ²		
CD b	-1	0	0	1	0	Xb/EJ
DC b	1	0	0	1	0	
DE b	-1+x/b	-Fx	Fx-Fx ² /b	1-2x/b+x ² /b ²	1/6Fb ² /EJ	1/3Xb/EJ
ED b	x/b	Fb-Fx	Fx-Fx ² /b	x ² /b ²		
EF √2b	0	√2/2Fx+1/2qx ²	0	0	0	0
FG b	0	-3/2Fx+1/2qx ²	0	0	0	0
GF b	0	Fb-1/2Fx-1/2qx ²	0	0	0	0
GA b	0	0	0	0	0	0
AG b	0	0	0	0	0	0
FB b	0	2Fb-2Fx	0	0	0	0
BF b	0	-2Fx	0	0	0	0
BE b	0	0	0	0	0	0
EB b	0	0	0	0	0	0
BE	elongazione asta $N_{1, BE} \epsilon_{BE} L_{BE}$				Fb ² /EJ	
	totali				11/6Fb ² /EJ	5/3Xb/EJ
	iperstatica X=W _{cd}				-11/10Fb	

Sviluppi di calcolo iperstatica

$$L_{BC}^{xx} = \int_0^b (x^2/b^2) 1/EJ dx = [1/3 x^3/b^2]_0^b 1/EJ$$

$$= (1/3 b) 1/EJ = 1/3 b/EJ$$

$$L_{CB}^{xx} = \int_0^b (1 - 2x/b + x^2/b^2) 1/EJ dx = [x - x^2/b + 1/3 x^3/b^2]_0^b 1/EJ$$

$$= (b - b + 1/3 b) 1/EJ = 1/3 b/EJ$$

$$L_{CD}^{xx} = \int_0^b (1) 1/EJ dx = [x]_0^b 1/EJ$$

$$= (b) 1/EJ = b/EJ$$

$$L_{DC}^{xx} = \int_0^b (1) 1/EJ dx = [x]_0^b 1/EJ$$

$$= (b) 1/EJ = b/EJ$$

$$L_{DE}^{xx} = \int_0^b (1 - 2x/b + x^2/b^2) 1/EJ dx = [x - x^2/b + 1/3 x^3/b^2]_0^b 1/EJ$$

$$= (b - b + 1/3 b) 1/EJ = 1/3 b/EJ$$

$$L_{ED}^{xx} = \int_0^b (x^2/b^2) 1/EJ dx = [1/3 x^3/b^2]_0^b 1/EJ$$

$$= (1/3 b) 1/EJ = 1/3 b/EJ$$

$$L_{BC}^{x_0} = \int_0^b (2x/b - x^2/b^2) Fb 1/EJ dx = [x^2/b - 1/3 x^3/b^2]_0^b Fb 1/EJ$$

$$= (b - 1/3 b) Fb 1/EJ = 2/3 Fb^2/EJ$$

$$L_{CB}^{x_0} = \int_0^b (1 - x^2/b^2) Fb 1/EJ dx = [x - 1/3 x^3/b^2]_0^b Fb 1/EJ$$

$$= (b - 1/3 b) Fb 1/EJ = 2/3 Fb^2/EJ$$

$$L_{DE}^{x_0} = \int_0^b (x/b - x^2/b^2) Fb 1/EJ dx = [1/2 x^2/b - 1/3 x^3/b^2]_0^b Fb 1/EJ$$

$$= (1/2 b - 1/3 b) Fb 1/EJ = 1/6 Fb^2/EJ$$

$$L_{ED}^{x_0} = \int_0^b (x/b - x^2/b^2) Fb 1/EJ dx = [1/2 x^2/b - 1/3 x^3/b^2]_0^b Fb 1/EJ$$

$$= (1/2 b - 1/3 b) Fb 1/EJ = 1/6 Fb^2/EJ$$

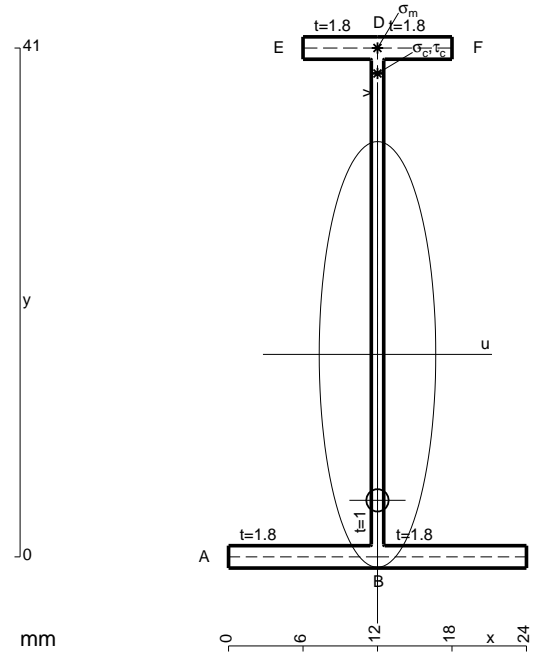

- A = 105.8 mm²
- J_u = 31122. mm⁴
- J_v = 2333. mm⁴
- J_I = 83.65 mm⁴
- y_o = -11.76 mm
- y_g = 16.31 mm
- N = 219.2 N
- T_y = 657.6 N
- M_x = 260400. Nmm
- x_m = 12. mm
- y_m = 41. mm
- v_m = 24.69 mm
- σ_m = N/A-Mv/J_u = -204.5 N/mm²
- y_c = 2. mm
- u_c = -12. mm
- v_c = -14.31 mm
- σ_c = N/A-Mv/J_u = -204.5 N/mm²
- τ_c = TS/tJ_u = 11.27 N/mm²
- τ_g = TS/tJ_u = 11.27 N/mm²
- t_c = 310. mm
- σ_o = √σ²+3τ² = 205.4 N/mm²

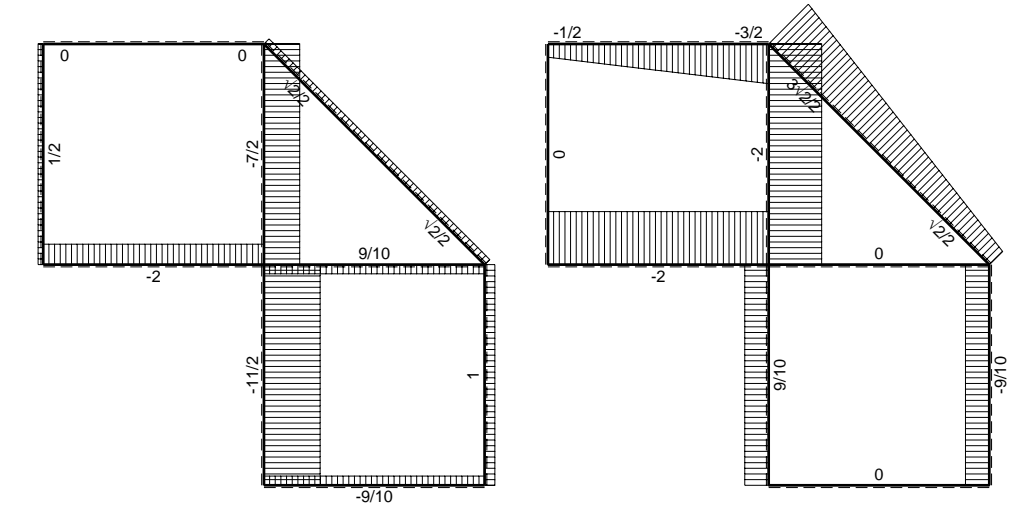
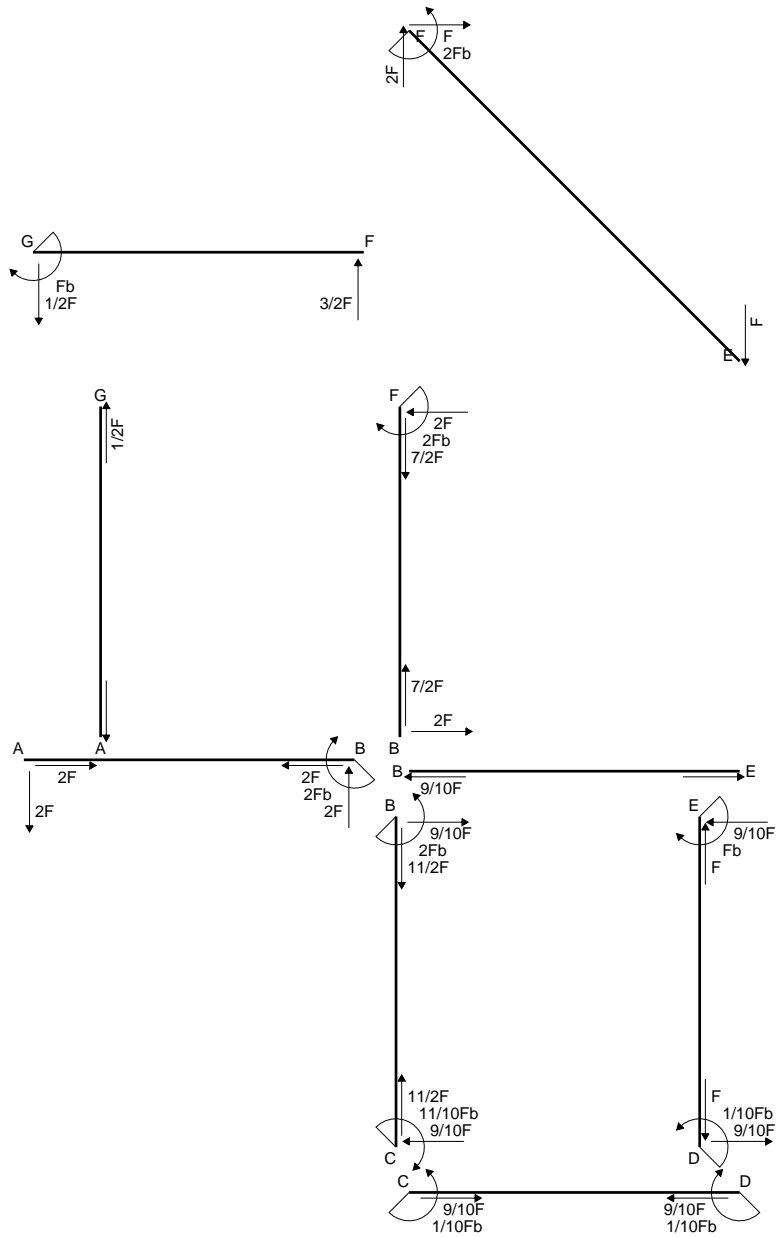

← ⊕ → F

↑ ⊕ ↓ F

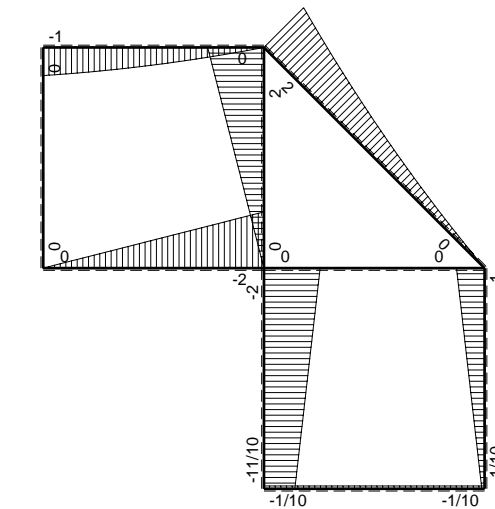

⊕ ⊖ F_b

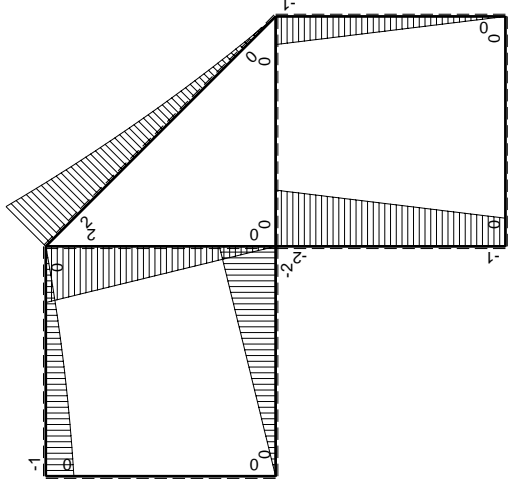
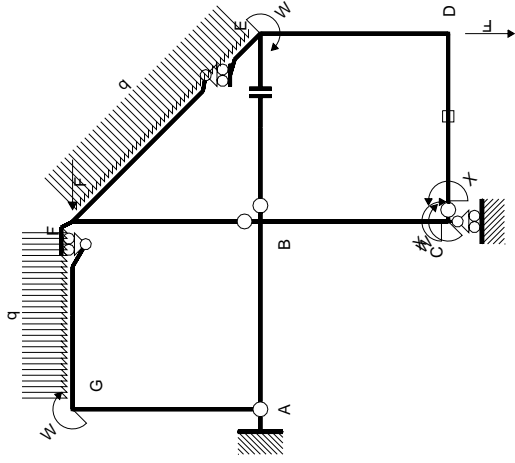

Schema di calcolo iperstatico

M_0 flessione da carichi assegnati

M_x flessione da iperstatica $X=1$

Quadro contribuiti PLV per iperstatica $X=W_{cd}$

\rightarrow	$M_x(x)$	$M_0(x)$	$M_x M_0$	$M_x M_x$	$\int M_x M_0 / E J dx$	$\int X M_x M_x / E J dx$
AB b	0	-2Fx	0	0	0	0
BA b	0	2Fb-2Fx	0	0	0	0
BC b	-x/b	-2Fb+Fx	2Fx-Fx ² /b	x ² /b ²	2/3Fb ² /EJ	1/3Xb/EJ
CB b	1-x/b	Fb+Fx	Fb-Fx ² /b	1-2x/b+x ² /b ²		
CD b	-1	0	0	1	0	Xb/EJ
DC b	1	0	0	1	0	
DE b	-1+x/b	-Fx	Fx-Fx ² /b	1-2x/b+x ² /b ²	1/6Fb ² /EJ	1/3Xb/EJ
ED b	x/b	Fb-Fx	Fx-Fx ² /b	x ² /b ²		
EF $\sqrt{2}b$	0	$\sqrt{2}/2Fx+1/2qx^2$	0	0	0	0
FG b	0	-3/2Fx+1/2qx ²	0	0	0	0
GF b	0	Fb-1/2Fx-1/2qx ²	0	0	0	0
GA b	0	0	0	0	0	0
AG b	0	0	0	0	0	0
FB b	0	2Fb-2Fx	0	0	0	0
BF b	0	-2Fx	0	0	0	0
BE b	0	0	0	0	0	0
EB b	0	0	0	0	0	0
CD	elongazione asta $N_{1,cd} \epsilon_{cd} L_{cd}$				-Fb ² /EJ	
	totali				-1/6Fb ² /EJ	5/3Xb/EJ
	iperstatica $X=W_{cd}$				1/10Fb	

Sviluppi di calcolo iperstatica

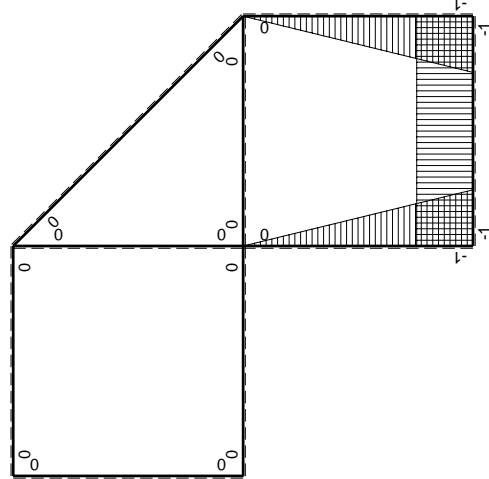

$$L_{BC}^{xx} = \int_0^b (x^2/b^2) 1/EJ dx = [1/3 x^3/b^2]_0^b 1/EJ$$

$$= (1/3 b) 1/EJ = 1/3 b/EJ$$

$$L_{CB}^{xx} = \int_0^b (1 - 2x/b + x^2/b^2) 1/EJ dx = [x - x^2/b + 1/3 x^3/b^2]_0^b 1/EJ$$

$$= (b - b + 1/3 b) 1/EJ = 1/3 b/EJ$$

$$L_{CD}^{xx} = \int_0^b (1) 1/EJ dx = [x]_0^b 1/EJ$$

$$= (b) 1/EJ = b/EJ$$

$$L_{DC}^{xx} = \int_0^b (1) 1/EJ dx = [x]_0^b 1/EJ$$

$$= (b) 1/EJ = b/EJ$$

$$L_{DE}^{xx} = \int_0^b (1 - 2x/b + x^2/b^2) 1/EJ dx = [x - x^2/b + 1/3 x^3/b^2]_0^b 1/EJ$$

$$= (b - b + 1/3 b) 1/EJ = 1/3 b/EJ$$

$$L_{ED}^{xx} = \int_0^b (x^2/b^2) 1/EJ dx = [1/3 x^3/b^2]_0^b 1/EJ$$

$$= (1/3 b) 1/EJ = 1/3 b/EJ$$

$$L_{BC}^{xo} = \int_0^b (2x/b - x^2/b^2) Fb 1/EJ dx = [x^2/b - 1/3 x^3/b^2]_0^b Fb 1/EJ$$

$$= (b - 1/3 b) Fb 1/EJ = 2/3 Fb^2/EJ$$

$$L_{CB}^{xo} = \int_0^b (1 - x^2/b^2) Fb 1/EJ dx = [x - 1/3 x^3/b^2]_0^b Fb 1/EJ$$

$$= (b - 1/3 b) Fb 1/EJ = 2/3 Fb^2/EJ$$

$$L_{DE}^{xo} = \int_0^b (x/b - x^2/b^2) Fb 1/EJ dx = [1/2 x^2/b - 1/3 x^3/b^2]_0^b Fb 1/EJ$$

$$= (1/2 b - 1/3 b) Fb 1/EJ = 1/6 Fb^2/EJ$$

$$L_{ED}^{xo} = \int_0^b (x/b - x^2/b^2) Fb 1/EJ dx = [1/2 x^2/b - 1/3 x^3/b^2]_0^b Fb 1/EJ$$

$$= (1/2 b - 1/3 b) Fb 1/EJ = 1/6 Fb^2/EJ$$

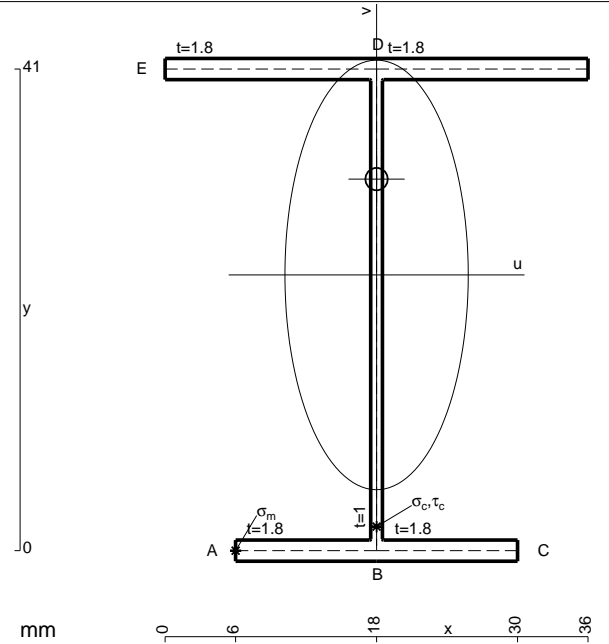

- A = 149. mm²
- J_u = 49815. mm⁴
- J_v = 9072. mm⁴
- J_t = 130.3 mm⁴
- y_o = 8.157 mm
- y_g = 23.47 mm
- N = 353.6 N
- T_y = 1061. N
- M_x = 460000. Nmm
- x_m = 6. mm
- u_m = -12. mm
- v_m = -23.47 mm
- σ_m = N/A-Mv/J_u = 219.1 N/mm²
- x_c = 18. mm
- v_c = -23.47 mm
- σ_c = N/A-Mv/J_u = 219.1 N/mm²
- τ_c = TS_t/tJ_u = 21.59 N/mm²
- τ_g = TS_t/tJ_u = 21.59 N/mm²
- t_c = 500. mm
- σ_o = √σ²+3τ² = 222.3 N/mm²

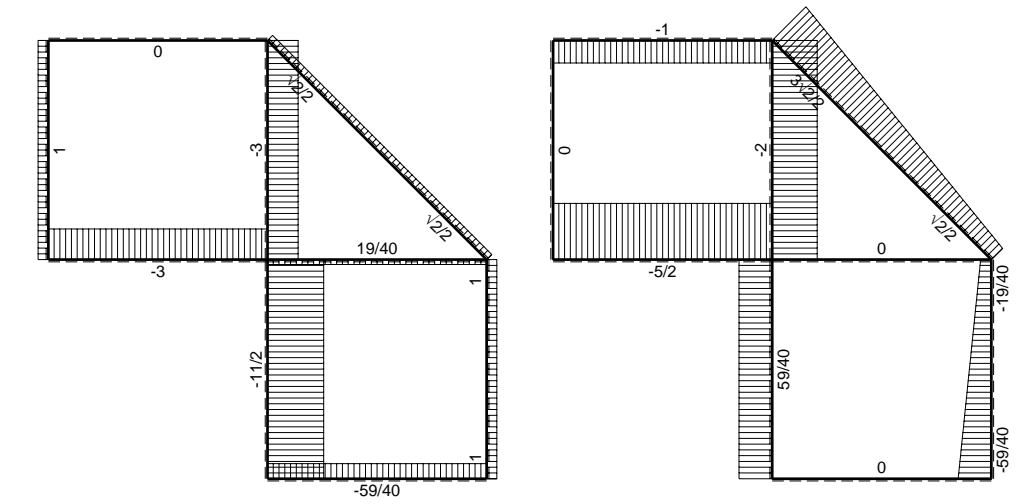
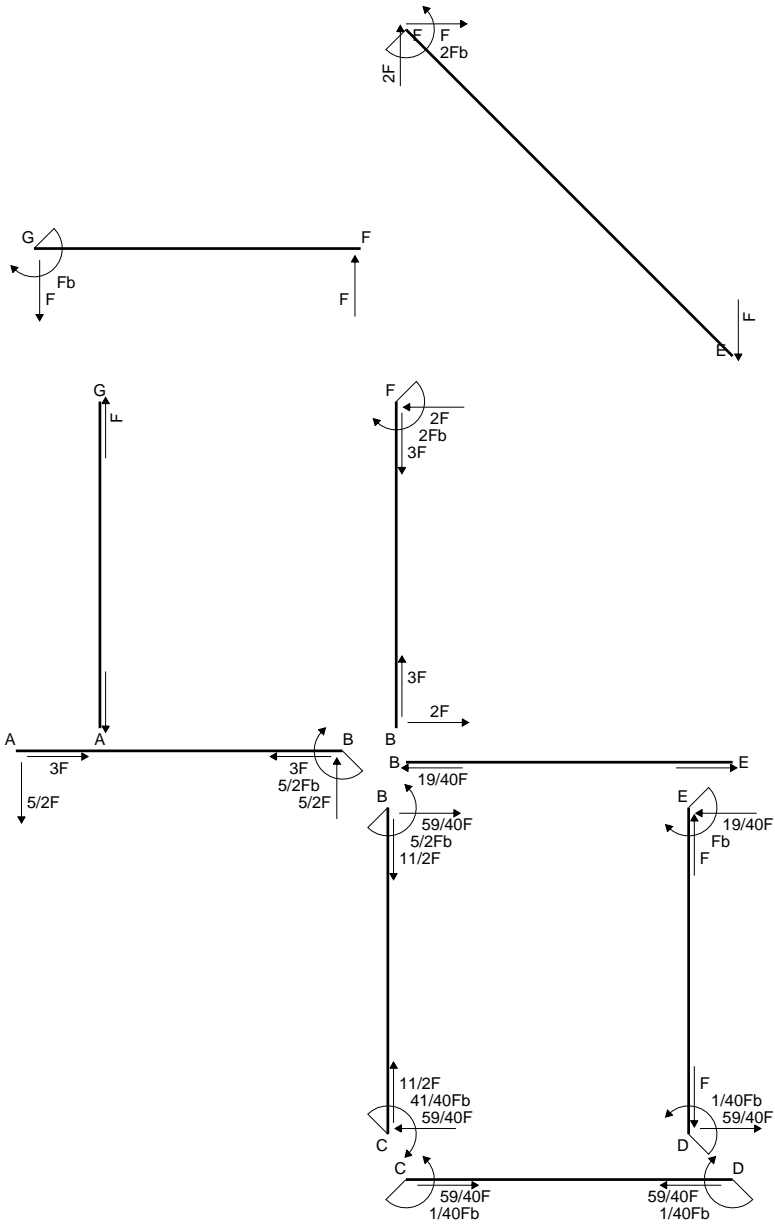

← ⊕ → F

↑ ⊕ ↓ F

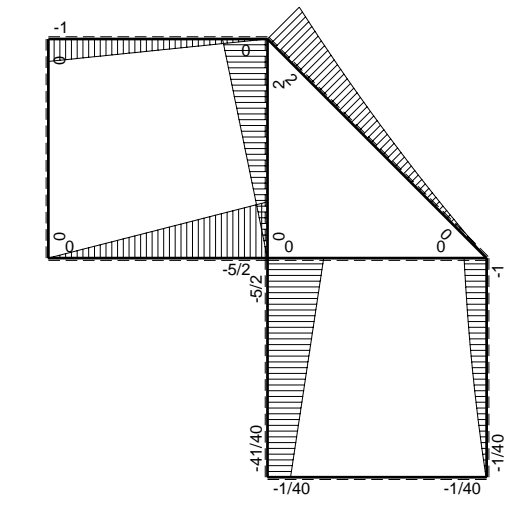

⊕ ⊖ Fb

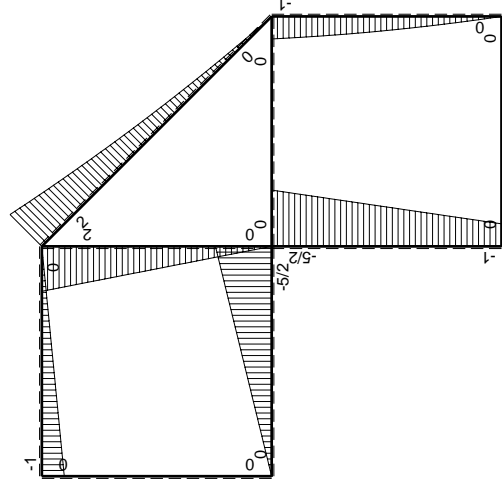
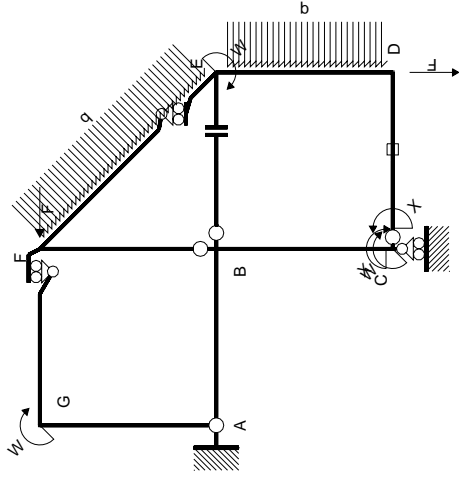

Schema di calcolo iperstatico

M_0 flessione da carichi assegnati

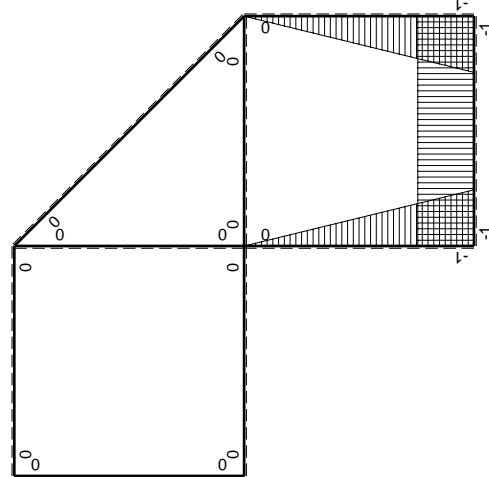

M_x flessione da iperstatica $X=1$

Quadro contribuiti PLV per iperstatica $X=W_{cd}$

\rightarrow	$M_x(x)$	$M_0(x)$	$M_x M_0$	$M_x M_x$	$\int M_x M_0 / EJ dx$	$\int M_x M_x / EJ dx$
AB b	0	-5/2Fx	0	0	0	0
BA b	0	5/2Fb-5/2Fx	0	0	0	0
BC b	-x/b	-5/2Fb+3/2Fx	5/2Fx-3/2Fx ² /b	x ² /b ²	3/4Fb ² /EJ	1/3Xb/EJ
CB b	1-x/b	Fb+3/2Fx	Fb+1/2Fx-3/2Fx ² /b	1-2x/b+x ² /b ²	0	Xb/EJ
CD b	-1	0	0	1	0	0
DC b	1	0	0	1	0	0
DE b	-1+x/b	-3/2Fx+1/2qx ²	3/2Fx-2Fx ² /b+1/2qx ³ /b	1-2x/b+x ² /b ²	5/24Fb ² /EJ	1/3Xb/EJ
ED b	x/b	Fb-1/2Fx-1/2qx ²	Fx-1/2Fx ² /b-1/2qx ³ /b	x ² /b ²	0	0
EF $\sqrt{2}b$	0	$\sqrt{2}Fx+1/2qx^2$	0	0	0	0
FG b	0	-Fx	0	0	0	0
GF b	0	Fb-Fx	0	0	0	0
GA b	0	0	0	0	0	0
AG b	0	0	0	0	0	0
FB b	0	2Fb-2Fx	0	0	0	0
BF b	0	-2Fx	0	0	0	0
BE b	0	0	0	0	0	0
EB b	0	0	0	0	0	0
CD	elongazione asta $N_{1,cd} \epsilon_{cd} L_{cd}$				-Fb ² /EJ	
	totali				-1/24Fb ² /EJ	5/3Xb/EJ
	iperstatica $X=W_{cd}$				1/40Fb	

Sviluppi di calcolo iperstatica

$$L_{BC}^{xx} = \int_0^b (x^2/b^2) 1/EJ dx = [1/3 x^3/b^2]_0^b 1/EJ$$

$$= (1/3 b) 1/EJ = 1/3 b/EJ$$

$$L_{CB}^{xx} = \int_0^b (1 - 2x/b + x^2/b^2) 1/EJ dx = [x - x^2/b + 1/3 x^3/b^2]_0^b 1/EJ$$

$$= (b - b + 1/3 b) 1/EJ = 1/3 b/EJ$$

$$L_{CD}^{xx} = \int_0^b (1) 1/EJ dx = [x]_0^b 1/EJ$$

$$= (b) 1/EJ = b/EJ$$

$$L_{DC}^{xx} = \int_0^b (1) 1/EJ dx = [x]_0^b 1/EJ$$

$$= (b) 1/EJ = b/EJ$$

$$L_{DE}^{xx} = \int_0^b (1 - 2x/b + x^2/b^2) 1/EJ dx = [x - x^2/b + 1/3 x^3/b^2]_0^b 1/EJ$$

$$= (b - b + 1/3 b) 1/EJ = 1/3 b/EJ$$

$$L_{ED}^{xx} = \int_0^b (x^2/b^2) 1/EJ dx = [1/3 x^3/b^2]_0^b 1/EJ$$

$$= (1/3 b) 1/EJ = 1/3 b/EJ$$

$$L_{BC}^{xo} = \int_0^b (5/2 x/b - 3/2 x^2/b^2) Fb 1/EJ dx = [5/4 x^2/b - 1/2 x^3/b^2]_0^b Fb 1/EJ$$

$$= (5/4 b - 1/2 b) Fb 1/EJ = 3/4 Fb^2/EJ$$

$$L_{CB}^{xo} = \int_0^b (1 + 1/2 x/b - 3/2 x^2/b^2) Fb 1/EJ dx = [x + 1/4 x^2/b - 1/2 x^3/b^2]_0^b Fb 1/EJ$$

$$= (b + 1/4 b - 1/2 b) Fb 1/EJ = 3/4 Fb^2/EJ$$

$$L_{DE}^{xo} = \int_0^b (3/2 x/b - 2 x^2/b^2 + 1/2 x^3/b^3) Fb 1/EJ dx = [3/4 x^2/b - 2/3 x^3/b^2 + 1/8 x^4/b^3]_0^b Fb 1/EJ$$

$$= (3/4 b - 2/3 b + 1/8 b) Fb 1/EJ = 5/24 Fb^2/EJ$$

$$L_{ED}^{xo} = \int_0^b (x/b - 1/2 x^2/b^2 - 1/2 x^3/b^3) Fb 1/EJ dx = [1/2 x^2/b - 1/6 x^3/b^2 - 1/8 x^4/b^3]_0^b Fb 1/EJ$$

$$= (1/2 b - 1/6 b - 1/8 b) Fb 1/EJ = 5/24 Fb^2/EJ$$

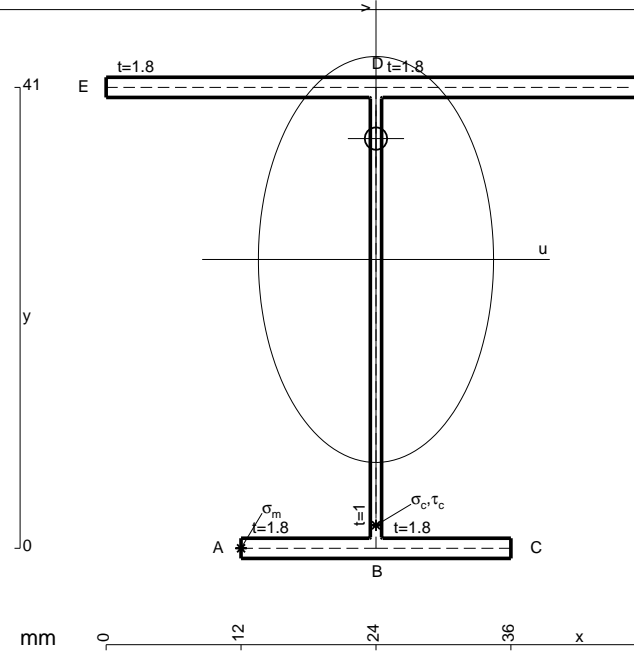

- A = 170.6 mm²
- J_u = 55611. mm⁴
- J_v = 18662. mm⁴
- J_t = 153.6 mm⁴
- y_o = 10.75 mm
- y_g = 25.69 mm
- N = -1140. N
- T_y = -950. N
- M_x = -475000. Nmm
- x_m = 12. mm
- u_m = -12. mm
- v_m = -25.69 mm
- σ_m = N/A-Mv/J_u = -226.1 N/mm²
- x_c = 24. mm
- v_c = -25.69 mm
- σ_c = N/A-Mv/J_u = -226.1 N/mm²
- τ_c = TS^{*}/tJ_u = 18.96 N/mm²
- τ_g = TS^{*}/tJ_u = 18.96 N/mm²
- t_c = 380. mm
- σ_o = √σ²+3τ² = 228.5 N/mm²

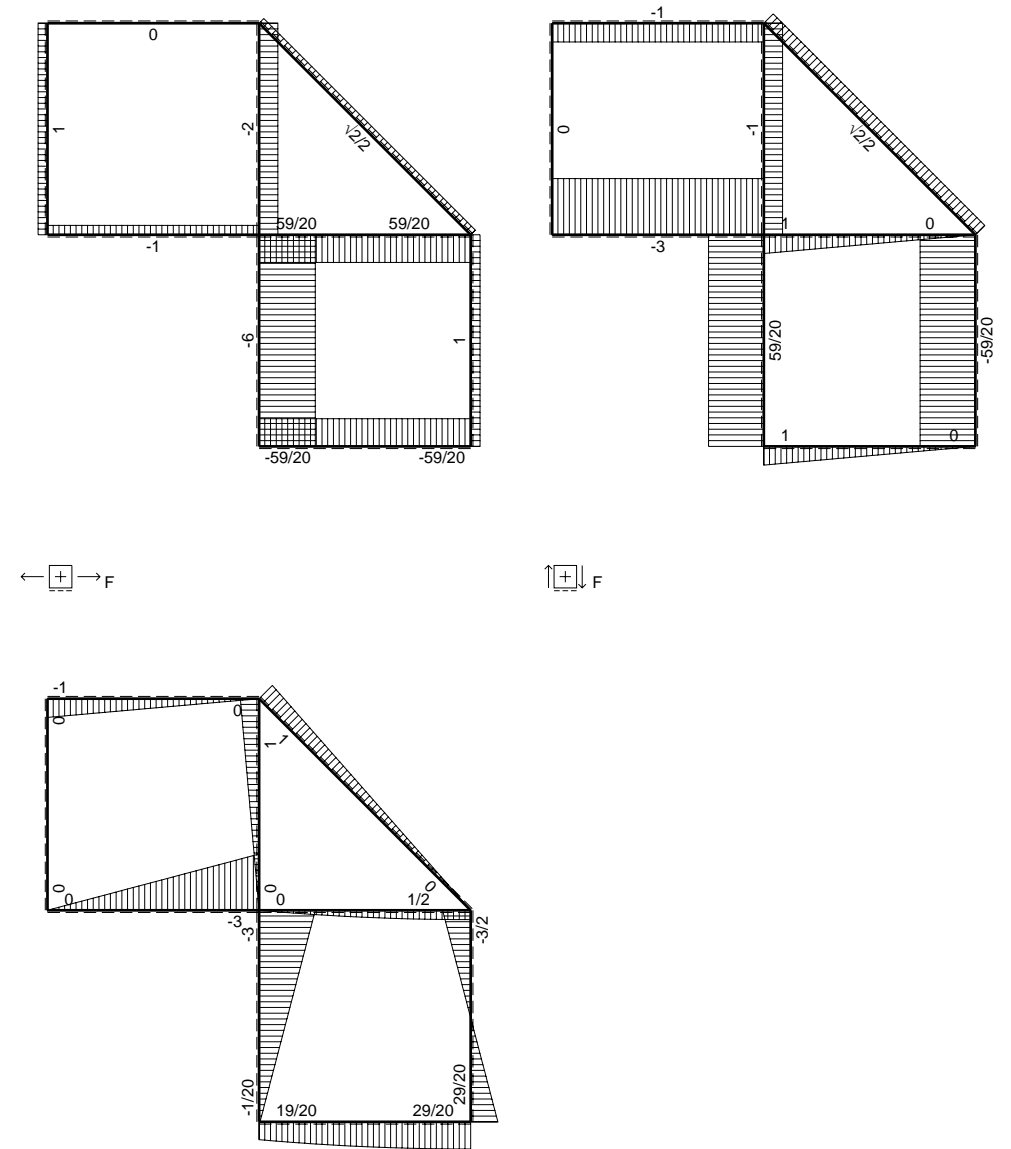
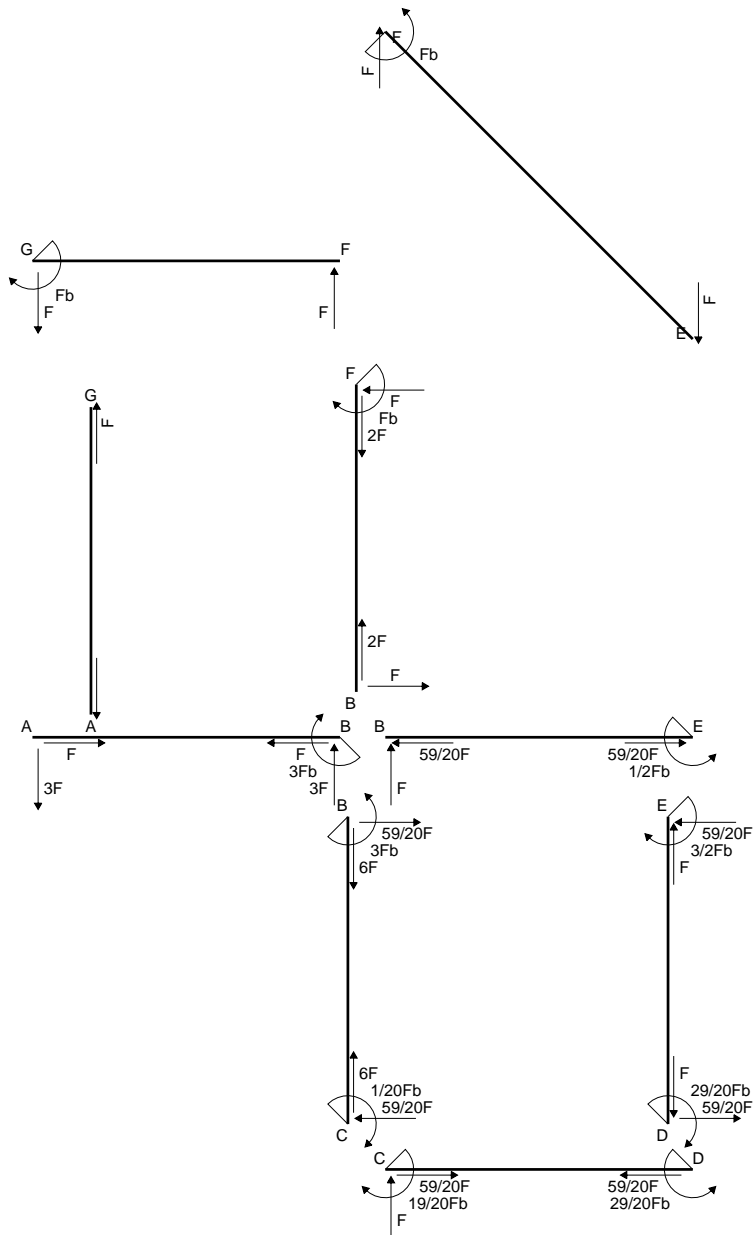

\oplus F_b

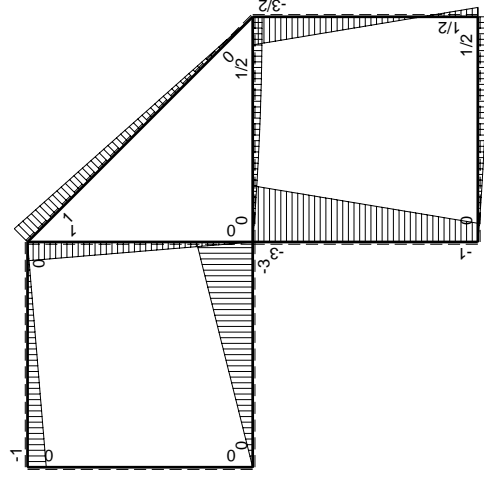
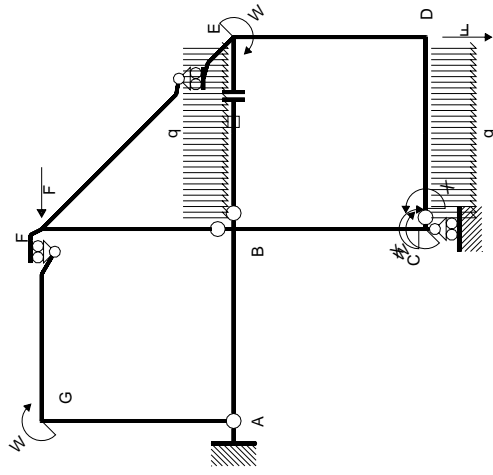

Schema di calcolo iperstatico

M_0 flessione da carichi assegnati

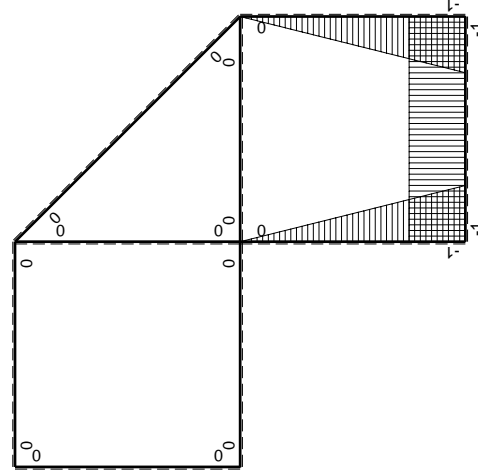

M_x flessione da iperstatica X=1

Quadro contribuiti PLV per iperstatica X=W_{CD}

→	$M_x(x)$	$M_0(x)$	$M_x M_0$	$M_x M_x$	$\int M_x M_0 / EJ dx$	$\int X M_x M_x / EJ dx$
AB b	0	-3Fx	0	0	0	0
BA b	0	3Fb-3Fx	0	0	0	0
BC b	-x/b	-3Fb+2Fx	$3Fx-2Fx^2/b$	x^2/b^2	$5/6Fb^2/EJ$	$1/3Xb/EJ$
CB b	1-x/b	Fb+2Fx	$Fb+Fx-2Fx^2/b$	$1-2x/b+x^2/b^2$	$-1/3Fb^2/EJ$	Xb/EJ
CD b	-1	$Fx-1/2qx^2$	$-Fx+1/2Fx^2/b$	1		
DC b	1	$-1/2Fb+1/2qx^2$	$-1/2Fb+1/2Fx^2/b$	1		
DE b	-1+x/b	$1/2Fb-2Fx$	$-1/2Fb+5/2Fx-2Fx^2/b$	$1-2x/b+x^2/b^2$	$1/12Fb^2/EJ$	$1/3Xb/EJ$
ED b	x/b	$3/2Fb-2Fx$	$3/2Fx-2Fx^2/b$	x^2/b^2		
EF $\sqrt{2}b$	0	$\sqrt{2}2Fx$	0	0	0	0
FG b	0	-Fx	0	0	0	0
GF b	0	Fb-Fx	0	0	0	0
GA b	0	0	0	0	0	0
AG b	0	0	0	0	0	0
FB b	0	Fb-Fx	0	0	0	0
BF b	0	-Fx	0	0	0	0
BE b	0	$Fx-1/2qx^2$	0	0	0	0
EB b	0	$-1/2Fb+1/2qx^2$	0	0	0	0
BE	elongazione asta $N_{1BE} \epsilon_{BE} = L_{BE}$				Fb^2/EJ	
	totali				$19/12Fb^2/EJ$	$5/3Xb/EJ$
	iperstatica X=W _{CD}				$-19/20Fb$	

Sviluppi di calcolo iperstatica

$$L_{BC}^{xx} = \int_0^b (x^2/b^2) 1/EJ dx = [1/3 x^3/b^2]_0^b 1/EJ$$

$$= (1/3 b) 1/EJ = 1/3 b/EJ$$

$$L_{CB}^{xx} = \int_0^b (1 - 2x/b + x^2/b^2) 1/EJ dx = [x - x^2/b + 1/3 x^3/b^2]_0^b 1/EJ$$

$$= (b - b + 1/3 b) 1/EJ = 1/3 b/EJ$$

$$L_{CD}^{xx} = \int_0^b (1) 1/EJ dx = [x]_0^b 1/EJ$$

$$= (b) 1/EJ = b/EJ$$

$$L_{DC}^{xx} = \int_0^b (1) 1/EJ dx = [x]_0^b 1/EJ$$

$$= (b) 1/EJ = b/EJ$$

$$L_{DE}^{xx} = \int_0^b (1 - 2x/b + x^2/b^2) 1/EJ dx = [x - x^2/b + 1/3 x^3/b^2]_0^b 1/EJ$$

$$= (b - b + 1/3 b) 1/EJ = 1/3 b/EJ$$

$$L_{ED}^{xx} = \int_0^b (x^2/b^2) 1/EJ dx = [1/3 x^3/b^2]_0^b 1/EJ$$

$$= (1/3 b) 1/EJ = 1/3 b/EJ$$

$$L_{BC}^{x_0} = \int_0^b (3x/b - 2x^2/b^2) Fb 1/EJ dx = [3/2 x^2/b - 2/3 x^3/b^2]_0^b Fb 1/EJ$$

$$= (3/2 b - 2/3 b) Fb 1/EJ = 5/6 Fb^2/EJ$$

$$L_{CB}^{x_0} = \int_0^b (1 + x/b - 2x^2/b^2) Fb 1/EJ dx = [x + 1/2 x^2/b - 2/3 x^3/b^2]_0^b Fb 1/EJ$$

$$= (b + 1/2 b - 2/3 b) Fb 1/EJ = 5/6 Fb^2/EJ$$

$$L_{CD}^{x_0} = \int_0^b (-x/b + 1/2 x^2/b^2) Fb 1/EJ dx = [-1/2 x^2/b + 1/6 x^3/b^2]_0^b Fb 1/EJ$$

$$= (-1/2 b + 1/6 b) Fb 1/EJ = -1/3 Fb^2/EJ$$

$$L_{DC}^{x_0} = \int_0^b (-1/2 + 1/2 x^2/b^2) Fb 1/EJ dx = [-1/2 x + 1/6 x^3/b^2]_0^b Fb 1/EJ$$

$$= (-1/2 b + 1/6 b) Fb 1/EJ = -1/3 Fb^2/EJ$$

$$L_{DE}^{x_0} = \int_0^b (-1/2 + 5/2 x/b - 2x^2/b^2) Fb 1/EJ dx = [-1/2 x + 5/4 x^2/b - 2/3 x^3/b^2]_0^b Fb 1/EJ$$

$$= (-1/2 b + 5/4 b - 2/3 b) Fb 1/EJ = 1/12 Fb^2/EJ$$

$$L_{ED}^{x_0} = \int_0^b (3/2 x/b - 2x^2/b^2) Fb 1/EJ dx = [3/4 x^2/b - 2/3 x^3/b^2]_0^b Fb 1/EJ$$

$$= (3/4 b - 2/3 b) Fb 1/EJ = 1/12 Fb^2/EJ$$

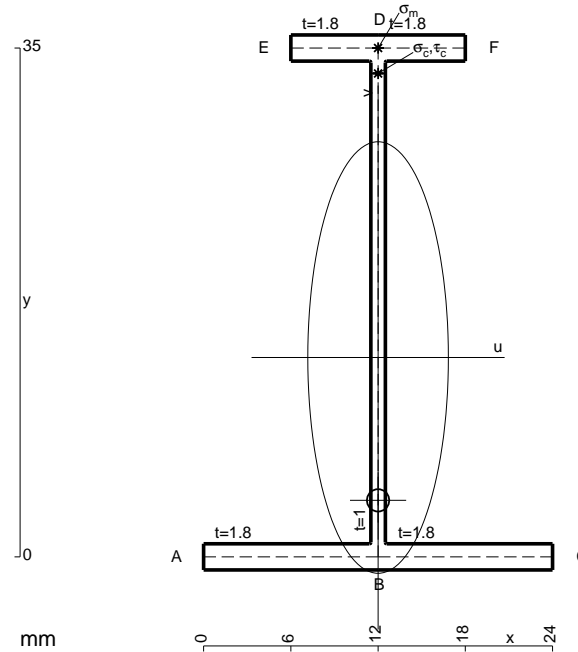

- A = 99.8 mm²
- J_u = 21986. mm⁴
- J_v = 2333. mm⁴
- J_t = 81.65 mm⁴
- y_o = -9.824 mm
- y_g = 13.71 mm
- N = -180. N
- T_y = -540. N
- M_x = -248400. Nmm
- x_m = 12. mm
- y_m = 35. mm
- v_m = 21.29 mm
- σ_m = N/A-Mv/J_u = 238.7 N/mm²
- y_c = 2. mm
- u_c = -12. mm
- v_c = -11.71 mm
- σ_c = N/A-Mv/J_u = 238.7 N/mm²
- τ_c = TS_v/tJ_u = 11.29 N/mm²
- τ_g = TS_v/tJ_u = 11.29 N/mm²
- t_c = 180. mm
- σ_o = √σ²+3τ² = 239.5 N/mm²

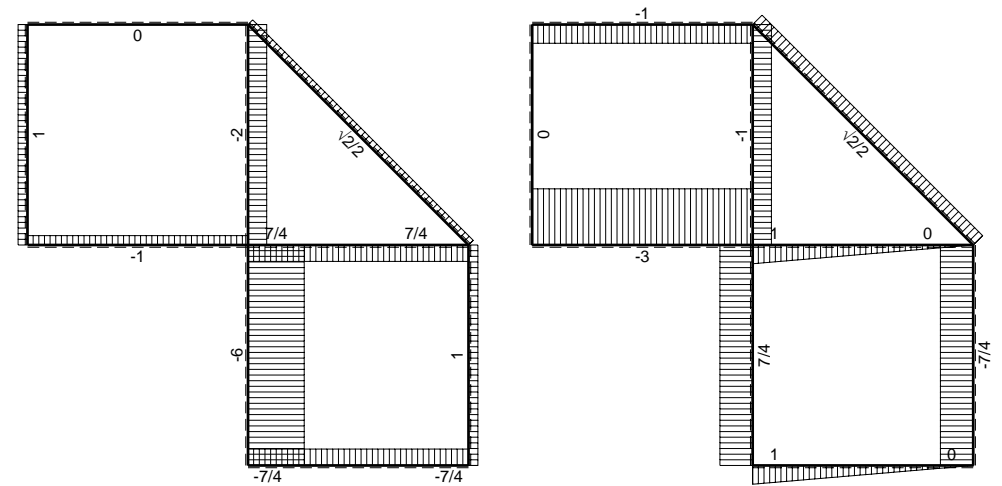
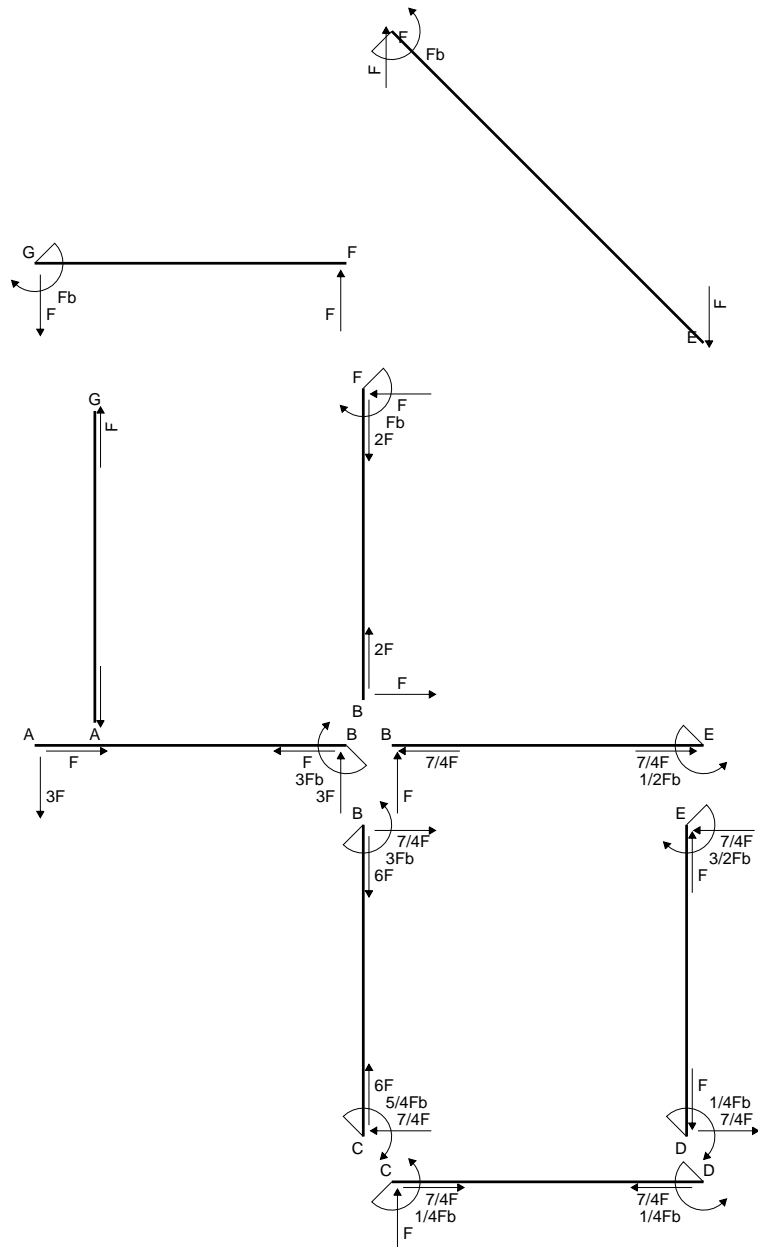

← ⊕ → F

↑ ⊕ ↓ F

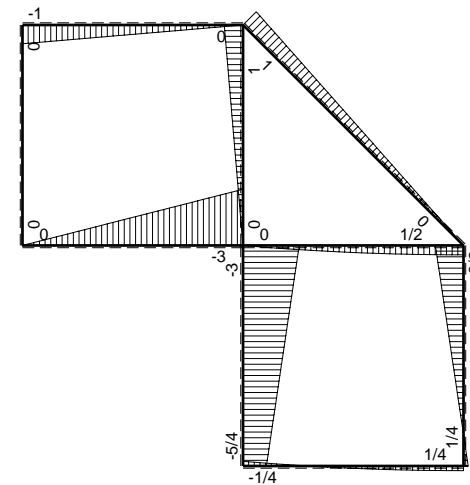

⊕ ⊖ F_b

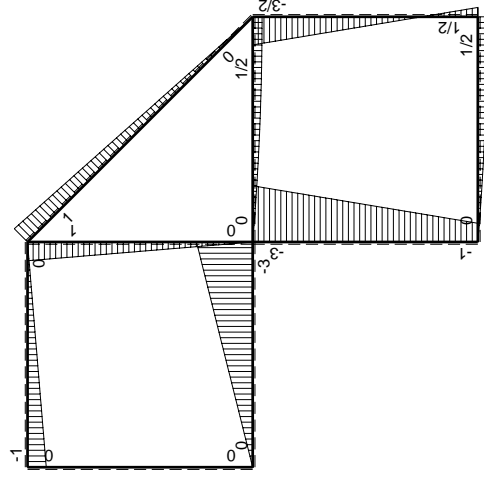
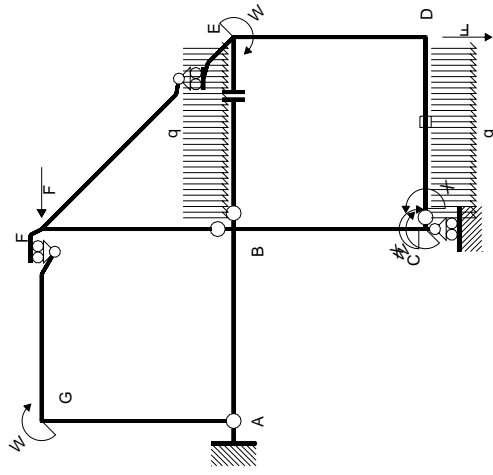

Schema di calcolo iperstatico

M_0 flessione da carichi assegnati

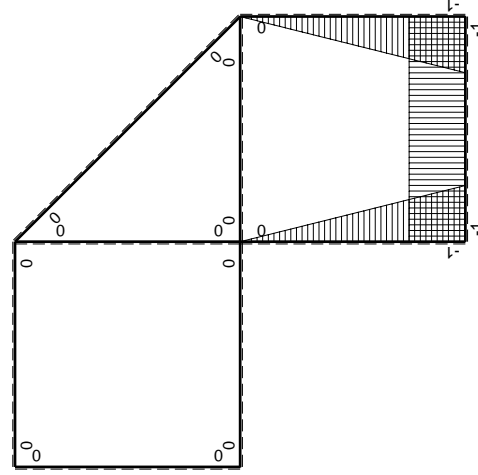

M_x flessione da iperstatica $X=1$

Quadro contribuiti PLV per iperstatica $X=W_{cd}$

\rightarrow	$M_x(x)$	$M_0(x)$	$M_x M_0$	$M_x M_x$	$\int M_x M_0 / EJ dx$	$\int X M_x M_x / EJ dx$
AB b	0	-3Fx	0	0	0	0
BA b	0	3Fb-3Fx	0	0	0	0
BC b	-x/b	-3Fb+2Fx	$3Fx-2Fx^2/b$	x^2/b^2	$5/6Fb^2/EJ$	$1/3Xb/EJ$
CB b	1-x/b	Fb+2Fx	$Fb+Fx-2Fx^2/b$	$1-2x/b+x^2/b^2$	$-1/3Fb^2/EJ$	Xb/EJ
CD b	-1	$Fx-1/2qx^2$	$-Fx+1/2Fx^2/b$	1		
DC b	1	$-1/2Fb+1/2qx^2$	$-1/2Fb+1/2Fx^2/b$	1		
DE b	-1+x/b	$1/2Fb-2Fx$	$-1/2Fb+5/2Fx-2Fx^2/b$	$1-2x/b+x^2/b^2$	$1/12Fb^2/EJ$	$1/3Xb/EJ$
ED b	x/b	$3/2Fb-2Fx$	$3/2Fx-2Fx^2/b$	x^2/b^2		
EF $\sqrt{2}b$	0	$\sqrt{2}2Fx$	0	0	0	0
FG b	0	-Fx	0	0	0	0
GF b	0	Fb-Fx	0	0	0	0
GA b	0	0	0	0	0	0
AG b	0	0	0	0	0	0
FB b	0	Fb-Fx	0	0	0	0
BF b	0	-Fx	0	0	0	0
BE b	0	$Fx-1/2qx^2$	0	0	0	0
EB b	0	$-1/2Fb+1/2qx^2$	0	0	0	0
CD	elongazione asta $N_{1,cd} \epsilon_{cd} L_{cd}$				$-Fb^2/EJ$	
	totali				$-5/12Fb^2/EJ$	$5/3Xb/EJ$
	iperstatica $X=W_{cd}$				$1/4Fb$	

Sviluppi di calcolo iperstatica

$$L_{BC}^{xx} = \int_0^b (x^2/b^2) 1/EJ dx = [1/3 x^3/b^2]_0^b 1/EJ$$

$$= (1/3 b) 1/EJ = 1/3 b/EJ$$

$$L_{CB}^{xx} = \int_0^b (1 - 2x/b + x^2/b^2) 1/EJ dx = [x - x^2/b + 1/3 x^3/b^2]_0^b 1/EJ$$

$$= (b - b + 1/3 b) 1/EJ = 1/3 b/EJ$$

$$L_{CD}^{xx} = \int_0^b (1) 1/EJ dx = [x]_0^b 1/EJ$$

$$= (b) 1/EJ = b/EJ$$

$$L_{DC}^{xx} = \int_0^b (1) 1/EJ dx = [x]_0^b 1/EJ$$

$$= (b) 1/EJ = b/EJ$$

$$L_{DE}^{xx} = \int_0^b (1 - 2x/b + x^2/b^2) 1/EJ dx = [x - x^2/b + 1/3 x^3/b^2]_0^b 1/EJ$$

$$= (b - b + 1/3 b) 1/EJ = 1/3 b/EJ$$

$$L_{ED}^{xx} = \int_0^b (x^2/b^2) 1/EJ dx = [1/3 x^3/b^2]_0^b 1/EJ$$

$$= (1/3 b) 1/EJ = 1/3 b/EJ$$

$$L_{BC}^{x_0} = \int_0^b (3x/b - 2x^2/b^2) Fb 1/EJ dx = [3/2 x^2/b - 2/3 x^3/b^2]_0^b Fb 1/EJ$$

$$= (3/2 b - 2/3 b) Fb 1/EJ = 5/6 Fb^2/EJ$$

$$L_{CB}^{x_0} = \int_0^b (1 + x/b - 2x^2/b^2) Fb 1/EJ dx = [x + 1/2 x^2/b - 2/3 x^3/b^2]_0^b Fb 1/EJ$$

$$= (b + 1/2 b - 2/3 b) Fb 1/EJ = 5/6 Fb^2/EJ$$

$$L_{CD}^{x_0} = \int_0^b (-x/b + 1/2 x^2/b^2) Fb 1/EJ dx + 1 (-1) 1 Fb^2/EJ$$

$$= [-1/2 x^2/b + 1/6 x^3/b^2]_0^b Fb 1/EJ + 1 (-1) 1 Fb^2/EJ$$

$$= (-1/2 b + 1/6 b) Fb 1/EJ + 1 (-1) 1 Fb^2/EJ = -4/3 Fb^2/EJ$$

$$L_{DC}^{x_0} = \int_0^b (-1/2 + 1/2 x^2/b^2) Fb 1/EJ dx + 1 (-1) 1 Fb^2/EJ$$

$$= [-1/2 x + 1/6 x^3/b^2]_0^b Fb 1/EJ + 1 (-1) 1 Fb^2/EJ$$

$$= (-1/2 b + 1/6 b) Fb 1/EJ + 1 (-1) 1 Fb^2/EJ = -4/3 Fb^2/EJ$$

$$L_{DE}^{x_0} = \int_0^b (-1/2 + 5/2 x/b - 2x^2/b^2) Fb 1/EJ dx = [-1/2 x + 5/4 x^2/b - 2/3 x^3/b^2]_0^b Fb 1/EJ$$

$$= (-1/2 b + 5/4 b - 2/3 b) Fb 1/EJ = 1/12 Fb^2/EJ$$

$$L_{ED}^{x_0} = \int_0^b (3/2 x/b - 2x^2/b^2) Fb 1/EJ dx = [3/4 x^2/b - 2/3 x^3/b^2]_0^b Fb 1/EJ$$

$$= (3/4 b - 2/3 b) Fb 1/EJ = 1/12 Fb^2/EJ$$

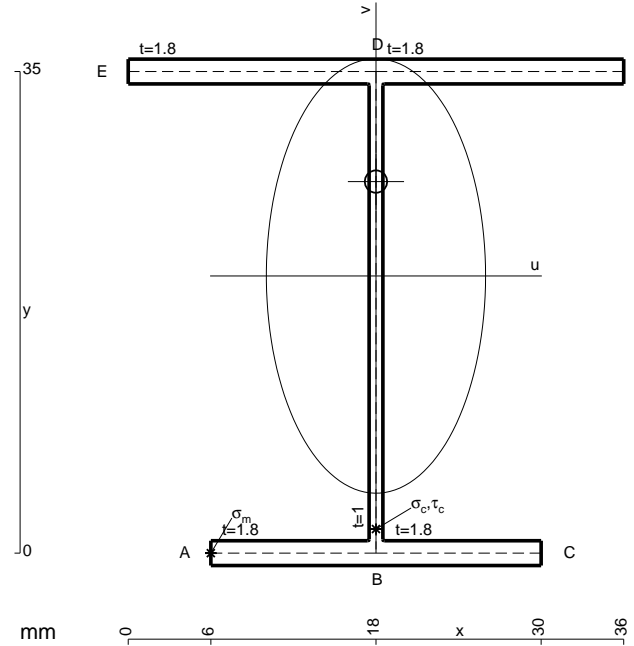

- A = 143. mm²
- J_u = 35649. mm⁴
- J_v = 9072. mm⁴
- J_t = 128.3 mm⁴
- y_o = 6.857 mm
- y_g = 20.14 mm
- N = -230. N
- T_y = -690. N
- M_x = -338100. Nmm
- x_m = 6. mm
- u_m = -12. mm
- v_m = -20.14 mm
- σ_m = N/A-Mv/J_u = -192.7 N/mm²
- x_c = 18. mm
- v_c = -20.14 mm
- σ_c = N/A-Mv/J_v = -192.7 N/mm²
- τ_c = TS/tJ_u = 16.84 N/mm²
- τ_g = TS/tJ_v = 16.84 N/mm²
- t_c = 230. mm
- σ_o = √σ²+3τ² = 194.8 N/mm²

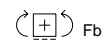
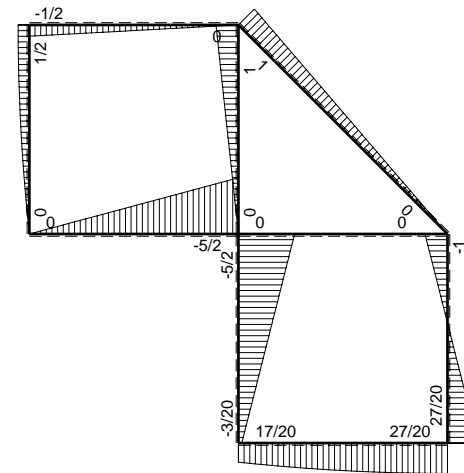
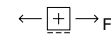
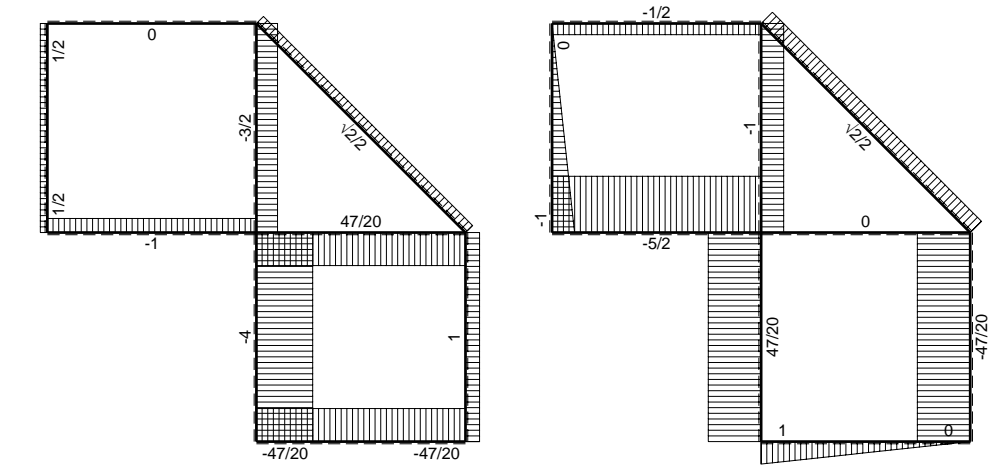
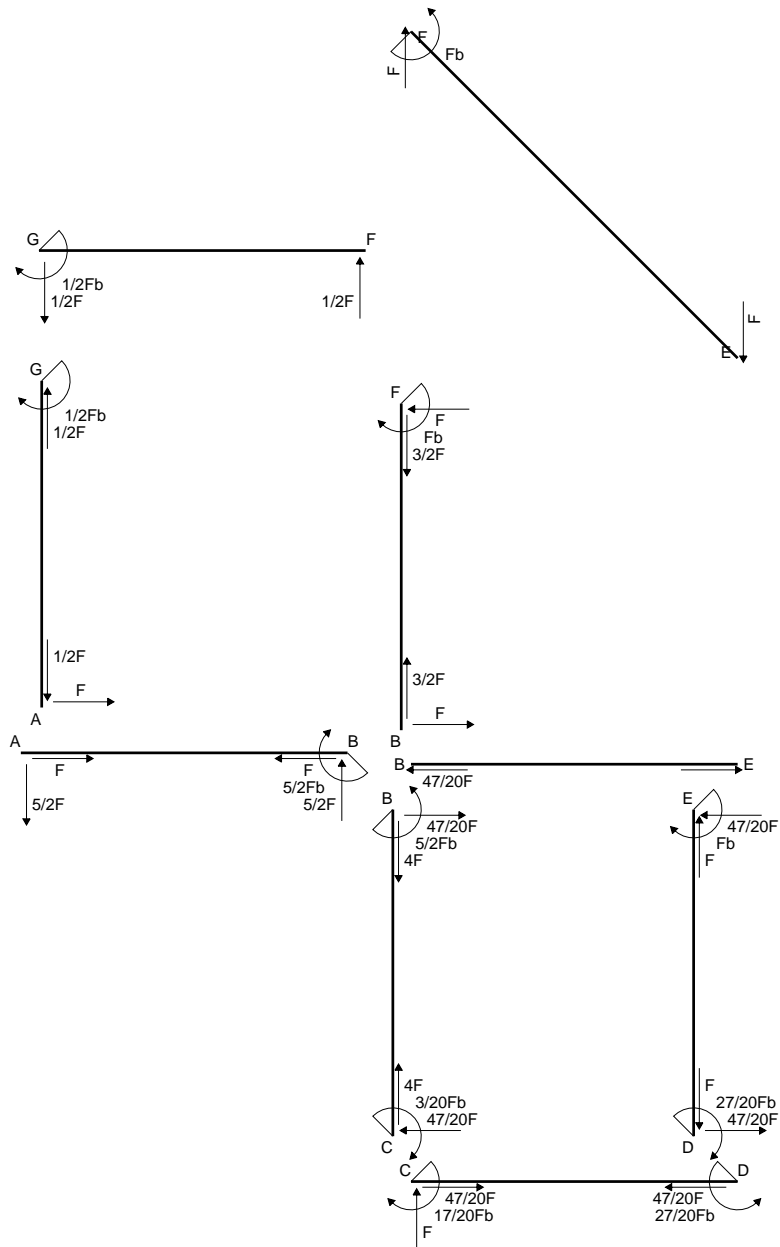

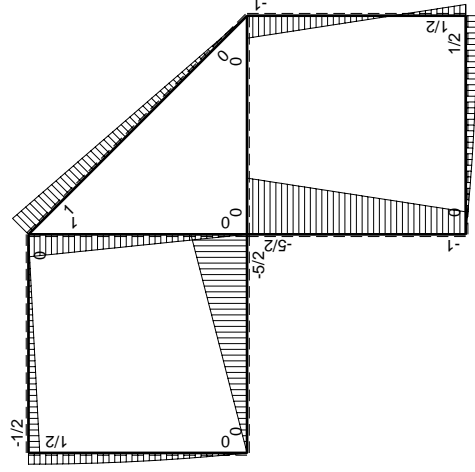
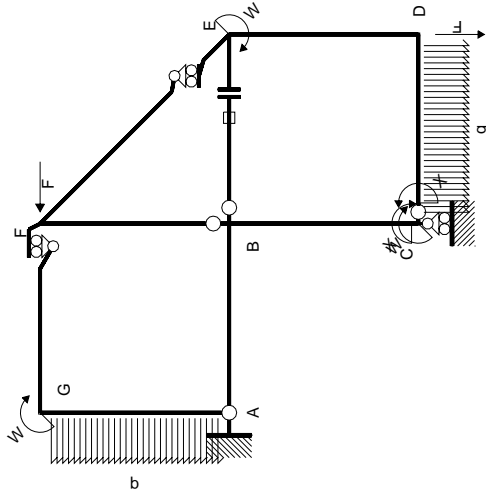

Schema di calcolo iperstatico

M_0 flessione da carichi assegnati

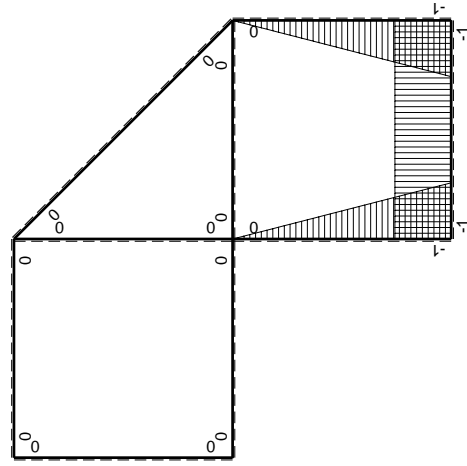

M_x flessione da iperstatica X=1

Quadro contribuiti PLV per iperstatica X=W_{cd}

→	$M_x(x)$	$M_0(x)$	$M_x M_0$	$M_x M_x$	$\int M_x M_0 / EJ dx$	$\int X M_x M_x / EJ dx$
AB b	0	-5/2Fx	0	0	0	0
BA b	0	5/2Fb-5/2Fx	0	0	0	0
BC b	-x/b	-5/2Fb+3/2Fx	5/2Fx-3/2Fx ² /b	x ² /b ²	3/4Fb ² /EJ	1/3Xb/EJ
CB b	1-x/b	Fb+3/2Fx	Fb+1/2Fx-3/2Fx ² /b	1-2x/b+x ² /b ²	-1/3Fb ² /EJ	Xb/EJ
CD b	-1	Fx-1/2qx ²	-Fx+1/2Fx ² /b	1	-1/3Fb ² /EJ	Xb/EJ
DC b	1	-1/2Fb+1/2qx ²	-1/2Fb+1/2Fx ² /b	1	-1/3Fb ² /EJ	Xb/EJ
DE b	-1+x/b	1/2Fb-3/2Fx	-1/2Fb+2Fx-3/2Fx ² /b	1-2x/b+x ² /b ²	0	1/3Xb/EJ
ED b	x/b	Fb-3/2Fx	Fx-3/2Fx ² /b	x ² /b ²	0	0
EF √2b	0	√2/2Fx	0	0	0	0
FG b	0	-1/2Fx	0	0	0	0
GF b	0	1/2Fb-1/2Fx	0	0	0	0
GA b	0	1/2Fb-1/2qx ²	0	0	0	0
AG b	0	-Fx+1/2qx ²	0	0	0	0
FB b	0	Fb-Fx	0	0	0	0
BF b	0	-Fx	0	0	0	0
BE b	0	0	0	0	0	0
EB b	0	0	0	0	0	0
BE	elongazione asta $N_{1, BE}^{\epsilon_{BE}} L_{BE}$				Fb ² /EJ	
	totali				17/12Fb ² /EJ	5/3Xb/EJ
	iperstatica X=W _{cd}				-17/20Fb	

Sviluppi di calcolo iperstatica

$$L_{BC}^{xx} = \int_0^b (x^2/b^2) 1/EJ dx = [1/3 x^3/b^2]_0^b 1/EJ$$

$$= (1/3 b) 1/EJ = 1/3 b/EJ$$

$$L_{CB}^{xx} = \int_0^b (1 - 2x/b + x^2/b^2) 1/EJ dx = [x - x^2/b + 1/3 x^3/b^2]_0^b 1/EJ$$

$$= (b - b + 1/3 b) 1/EJ = 1/3 b/EJ$$

$$L_{CD}^{xx} = \int_0^b (1) 1/EJ dx = [x]_0^b 1/EJ$$

$$= (b) 1/EJ = b/EJ$$

$$L_{DC}^{xx} = \int_0^b (1) 1/EJ dx = [x]_0^b 1/EJ$$

$$= (b) 1/EJ = b/EJ$$

$$L_{DE}^{xx} = \int_0^b (1 - 2x/b + x^2/b^2) 1/EJ dx = [x - x^2/b + 1/3 x^3/b^2]_0^b 1/EJ$$

$$= (b - b + 1/3 b) 1/EJ = 1/3 b/EJ$$

$$L_{ED}^{xx} = \int_0^b (x^2/b^2) 1/EJ dx = [1/3 x^3/b^2]_0^b 1/EJ$$

$$= (1/3 b) 1/EJ = 1/3 b/EJ$$

$$L_{BC}^{x_0} = \int_0^b (5/2 x/b - 3/2 x^2/b^2) Fb 1/EJ dx = [5/4 x^2/b - 1/2 x^3/b^2]_0^b Fb 1/EJ$$

$$= (5/4 b - 1/2 b) Fb 1/EJ = 3/4 Fb^2/EJ$$

$$L_{CB}^{x_0} = \int_0^b (1 + 1/2 x/b - 3/2 x^2/b^2) Fb 1/EJ dx = [x + 1/4 x^2/b - 1/2 x^3/b^2]_0^b Fb 1/EJ$$

$$= (b + 1/4 b - 1/2 b) Fb 1/EJ = 3/4 Fb^2/EJ$$

$$L_{CD}^{x_0} = \int_0^b (-x/b + 1/2 x^2/b^2) Fb 1/EJ dx = [-1/2 x^2/b + 1/6 x^3/b^2]_0^b Fb 1/EJ$$

$$= (-1/2 b + 1/6 b) Fb 1/EJ = -1/3 Fb^2/EJ$$

$$L_{DC}^{x_0} = \int_0^b (-1/2 + 1/2 x^2/b^2) Fb 1/EJ dx = [-1/2 x + 1/6 x^3/b^2]_0^b Fb 1/EJ$$

$$= (-1/2 b + 1/6 b) Fb 1/EJ = -1/3 Fb^2/EJ$$

$$L_{DE}^{x_0} = \int_0^b (-1/2 + 2x/b - 3/2 x^2/b^2) Fb 1/EJ dx = [-1/2 x + x^2/b - 1/2 x^3/b^2]_0^b Fb 1/EJ$$

$$= (-1/2 b + b - 1/2 b) Fb 1/EJ = 0$$

$$L_{ED}^{x_0} = \int_0^b (x/b - 3/2 x^2/b^2) Fb 1/EJ dx = [1/2 x^2/b - 1/2 x^3/b^2]_0^b Fb 1/EJ$$

$$= (1/2 b - 1/2 b) Fb 1/EJ = 0$$

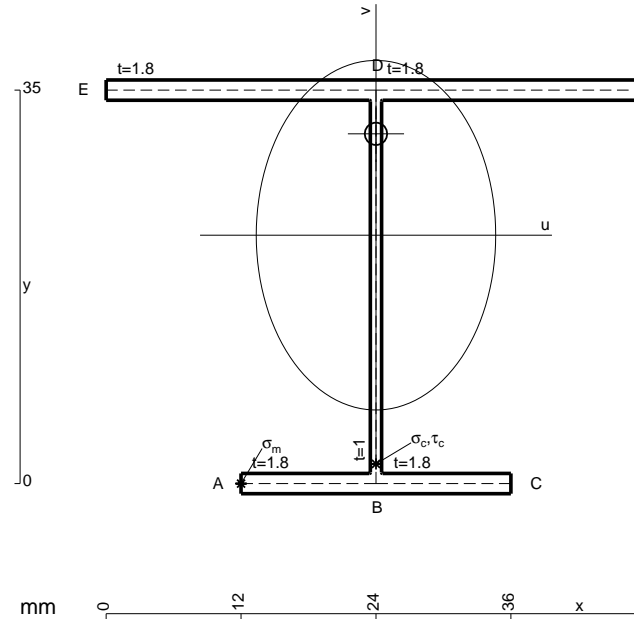

- A = 164.6 mm²
- J_u = 39791. mm⁴
- J_v = 18662. mm⁴
- J_i = 151.6 mm⁴
- y_o = 9.018 mm
- y_g = 22.09 mm
- N = -280. N
- T_y = -700. N
- M_x = -364000. Nmm
- x_m = 12. mm
- u_m = -12. mm
- v_m = -22.09 mm
- σ_m = N/A-Mv/J_u = -203.8 N/mm²
- x_c = 24. mm
- v_c = -22.09 mm
- σ_c = N/A-Mv/J_u = -203.8 N/mm²
- τ_c = TS¹/tJ_u = 16.79 N/mm²
- τ_g = TS¹/tJ_u = 16.79 N/mm²
- t_c = 280. mm
- σ_o = √σ²+3τ² = 205.9 N/mm²

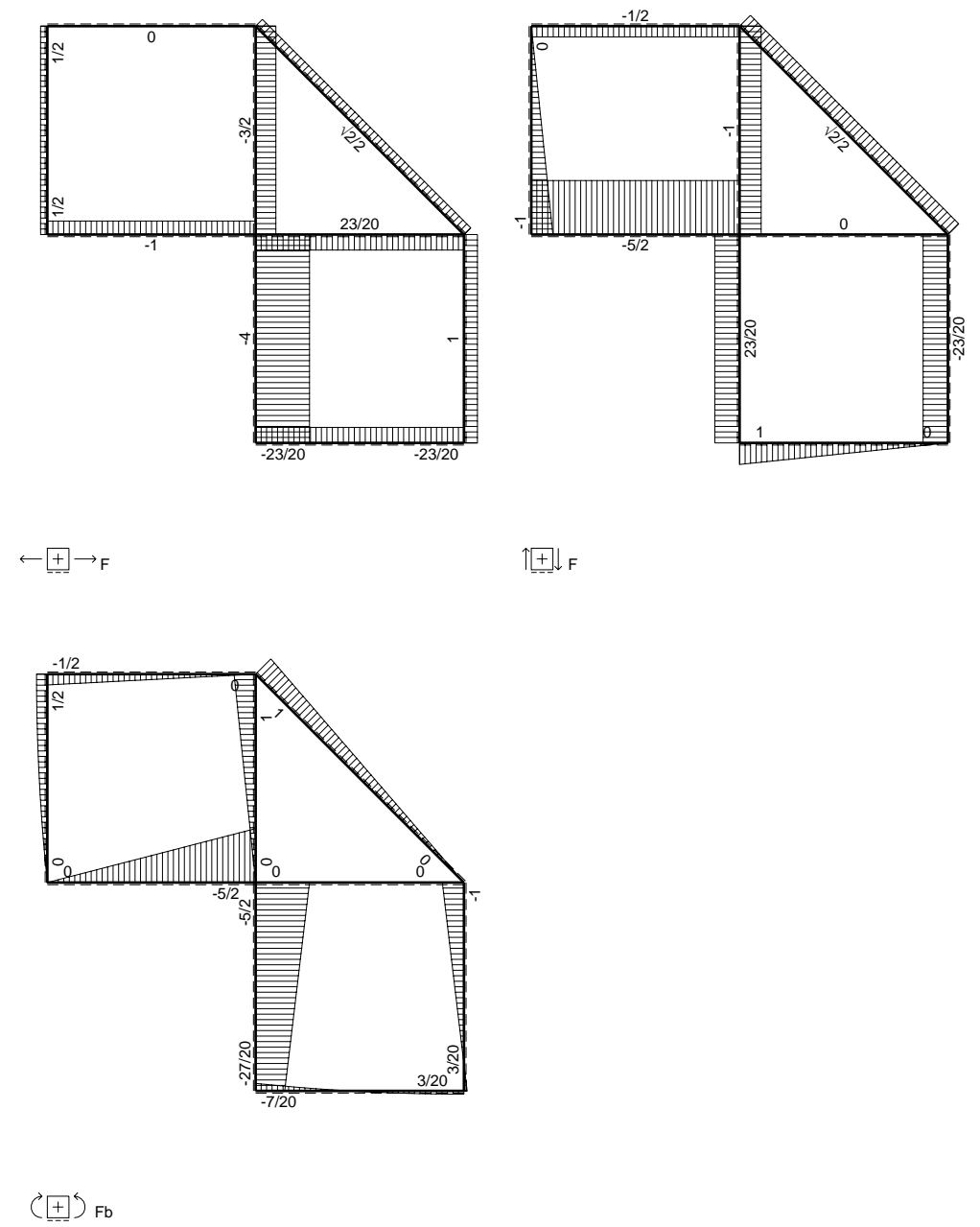
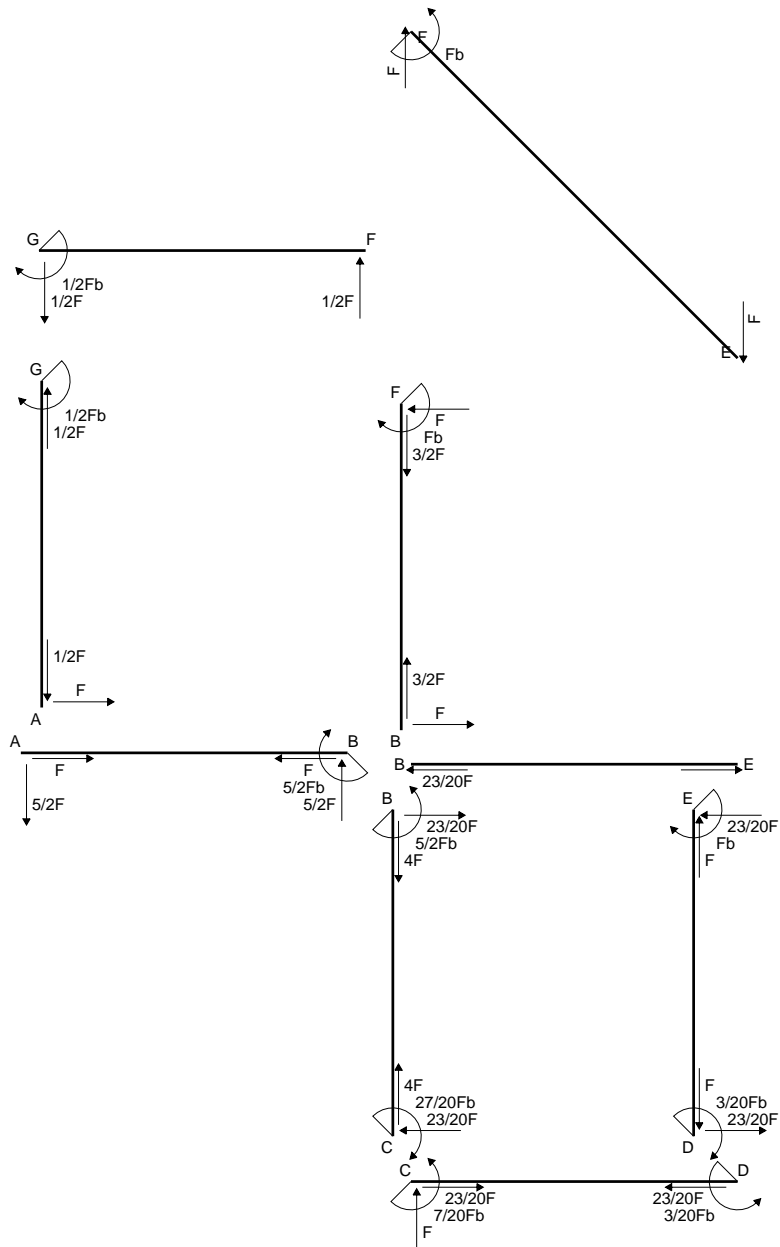

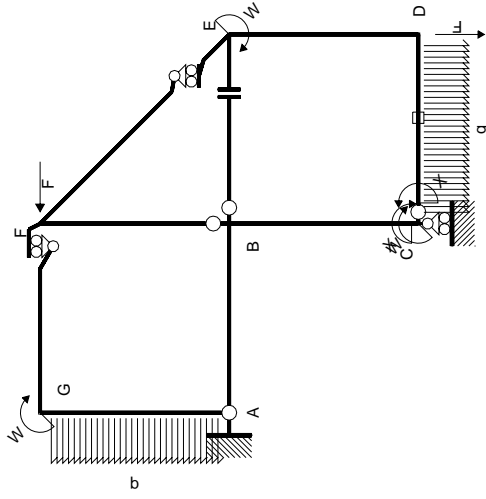

Schema di calcolo iperstatico

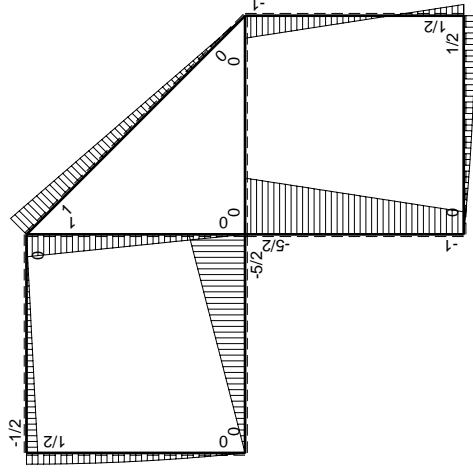

M₀ flessione da carichi assegnati

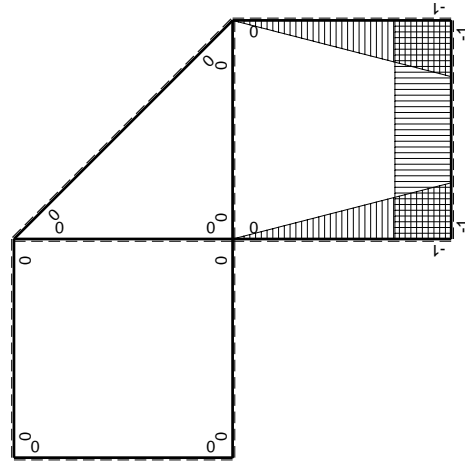

M_x flessione da iperstatica X=1

Quadro contributi PLV per iperstatica X=W_{cd}

→	M _x (x)	M ₀ (x)	M _x M ₀	M _x M _x	∫M _x M ₀ /EJdx	∫XM _x M _x /EJdx
AB b	0	-5/2Fx	0	0	0	0
BA b	0	5/2Fb-5/2Fx	0	0	0	0
BC b	-x/b	-5/2Fb+3/2Fx	5/2Fx-3/2Fx ² /b	x ² /b ²	3/4Fb ² /EJ	1/3Xb/EJ
CB b	1-x/b	Fb+3/2Fx	Fb+1/2Fx-3/2Fx ² /b	1-2x/b+x ² /b ²	-1/3Fb ² /EJ	Xb/EJ
CD b	-1	Fx-1/2qx ²	-Fx+1/2Fx ² /b	1	-1/3Fb ² /EJ	Xb/EJ
DC b	1	-1/2Fb+1/2qx ²	-1/2Fb+1/2Fx ² /b	1	-1/3Fb ² /EJ	Xb/EJ
DE b	-1+x/b	1/2Fb-3/2Fx	-1/2Fb+2Fx-3/2Fx ² /b	1-2x/b+x ² /b ²	0	1/3Xb/EJ
ED b	x/b	Fb-3/2Fx	Fx-3/2Fx ² /b	x ² /b ²	0	0
EF √2b	0	√2/2Fx	0	0	0	0
FG b	0	-1/2Fx	0	0	0	0
GF b	0	1/2Fb-1/2Fx	0	0	0	0
GA b	0	1/2Fb-1/2qx ²	0	0	0	0
AG b	0	-Fx+1/2qx ²	0	0	0	0
FB b	0	Fb-Fx	0	0	0	0
BF b	0	-Fx	0	0	0	0
BE b	0	0	0	0	0	0
EB b	0	0	0	0	0	0
CD	elongazione asta N _{1,cd} ε _{cd} L _{cd}				-Fb ² /EJ	
	totali				-7/12Fb ² /EJ	5/3Xb/EJ
	iperstatica X=W _{cd}				7/20Fb	

Sviluppi di calcolo iperstatica

$$L_{BC}^{xx} = \int_0^b (x^2/b^2) 1/EJ dx = [1/3 x^3/b^2]_0^b 1/EJ$$

$$= (1/3 b) 1/EJ = 1/3 b/EJ$$

$$L_{CB}^{xx} = \int_0^b (1 - 2x/b + x^2/b^2) 1/EJ dx = [x - x^2/b + 1/3 x^3/b^2]_0^b 1/EJ$$

$$= (b - b + 1/3 b) 1/EJ = 1/3 b/EJ$$

$$L_{CD}^{xx} = \int_0^b (1) 1/EJ dx = [x]_0^b 1/EJ$$

$$= (b) 1/EJ = b/EJ$$

$$L_{DC}^{xx} = \int_0^b (1) 1/EJ dx = [x]_0^b 1/EJ$$

$$= (b) 1/EJ = b/EJ$$

$$L_{DE}^{xx} = \int_0^b (1 - 2x/b + x^2/b^2) 1/EJ dx = [x - x^2/b + 1/3 x^3/b^2]_0^b 1/EJ$$

$$= (b - b + 1/3 b) 1/EJ = 1/3 b/EJ$$

$$L_{ED}^{xx} = \int_0^b (x^2/b^2) 1/EJ dx = [1/3 x^3/b^2]_0^b 1/EJ$$

$$= (1/3 b) 1/EJ = 1/3 b/EJ$$

$$L_{BC}^{xo} = \int_0^b (5/2 x/b - 3/2 x^2/b^2) Fb 1/EJ dx = [5/4 x^2/b - 1/2 x^3/b^2]_0^b Fb 1/EJ$$

$$= (5/4 b - 1/2 b) Fb 1/EJ = 3/4 Fb^2/EJ$$

$$L_{CB}^{xo} = \int_0^b (1 + 1/2 x/b - 3/2 x^2/b^2) Fb 1/EJ dx = [x + 1/4 x^2/b - 1/2 x^3/b^2]_0^b Fb 1/EJ$$

$$= (b + 1/4 b - 1/2 b) Fb 1/EJ = 3/4 Fb^2/EJ$$

$$L_{CD}^{xo} = \int_0^b (-x/b + 1/2 x^2/b^2) Fb 1/EJ dx + 1 (-1) 1 Fb^2/EJ$$

$$= [-1/2 x^2/b + 1/6 x^3/b^2]_0^b Fb 1/EJ + 1 (-1) 1 Fb^2/EJ$$

$$= (-1/2 b + 1/6 b) Fb 1/EJ + 1 (-1) 1 Fb^2/EJ = -4/3 Fb^2/EJ$$

$$L_{DC}^{xo} = \int_0^b (-1/2 + 1/2 x^2/b^2) Fb 1/EJ dx + 1 (-1) 1 Fb^2/EJ$$

$$= [-1/2 x + 1/6 x^3/b^2]_0^b Fb 1/EJ + 1 (-1) 1 Fb^2/EJ$$

$$= (-1/2 b + 1/6 b) Fb 1/EJ + 1 (-1) 1 Fb^2/EJ = -4/3 Fb^2/EJ$$

$$L_{DE}^{xo} = \int_0^b (-1/2 + 2x/b - 3/2 x^2/b^2) Fb 1/EJ dx = [-1/2 x + x^2/b - 1/2 x^3/b^2]_0^b Fb 1/EJ$$

$$= (-1/2 b + b - 1/2 b) Fb 1/EJ = 0$$

$$L_{ED}^{xo} = \int_0^b (x/b - 3/2 x^2/b^2) Fb 1/EJ dx = [1/2 x^2/b - 1/2 x^3/b^2]_0^b Fb 1/EJ$$

$$= (1/2 b - 1/2 b) Fb 1/EJ = 0$$

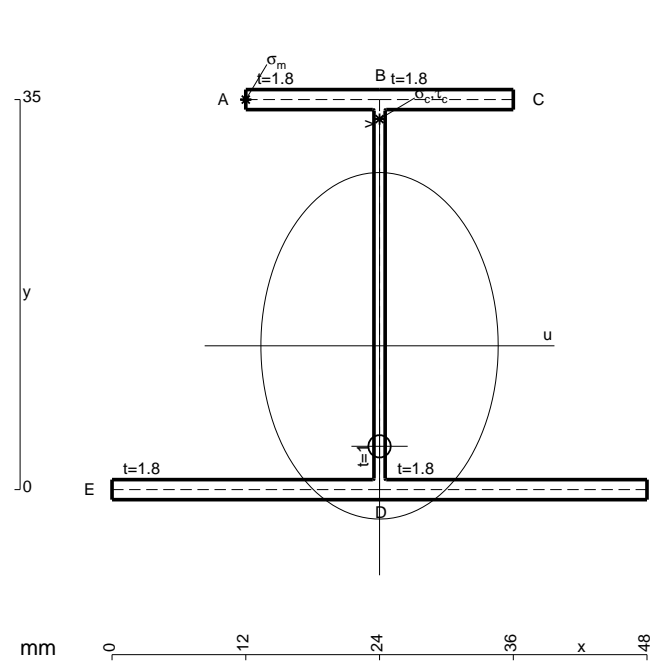

- A = 164.6 mm²
- J_u = 39791. mm⁴
- J_v = 18662. mm⁴
- J_t = 151.6 mm⁴
- y_o = -9.018 mm
- y_g = 12.91 mm
- N = -280. N
- T_y = -700. N
- M_x = -392000. Nmm
- x_m = 12. mm
- y_m = 35. mm
- u_m = -12. mm
- v_m = 22.09 mm
- σ_m = N/A-Mv/J_u = 215.9 N/mm²
- x_c = 24. mm
- y_c = 35. mm
- v_c = 22.09 mm
- σ_c = N/A-Mv/J_u = 215.9 N/mm²
- τ_c = TS'/tJ_u = 16.79 N/mm²
- τ_g = TS'/tJ_u = 16.79 N/mm²
- t_c = 280. mm
- σ_o = √(σ²+3τ²) = 217.9 N/mm²

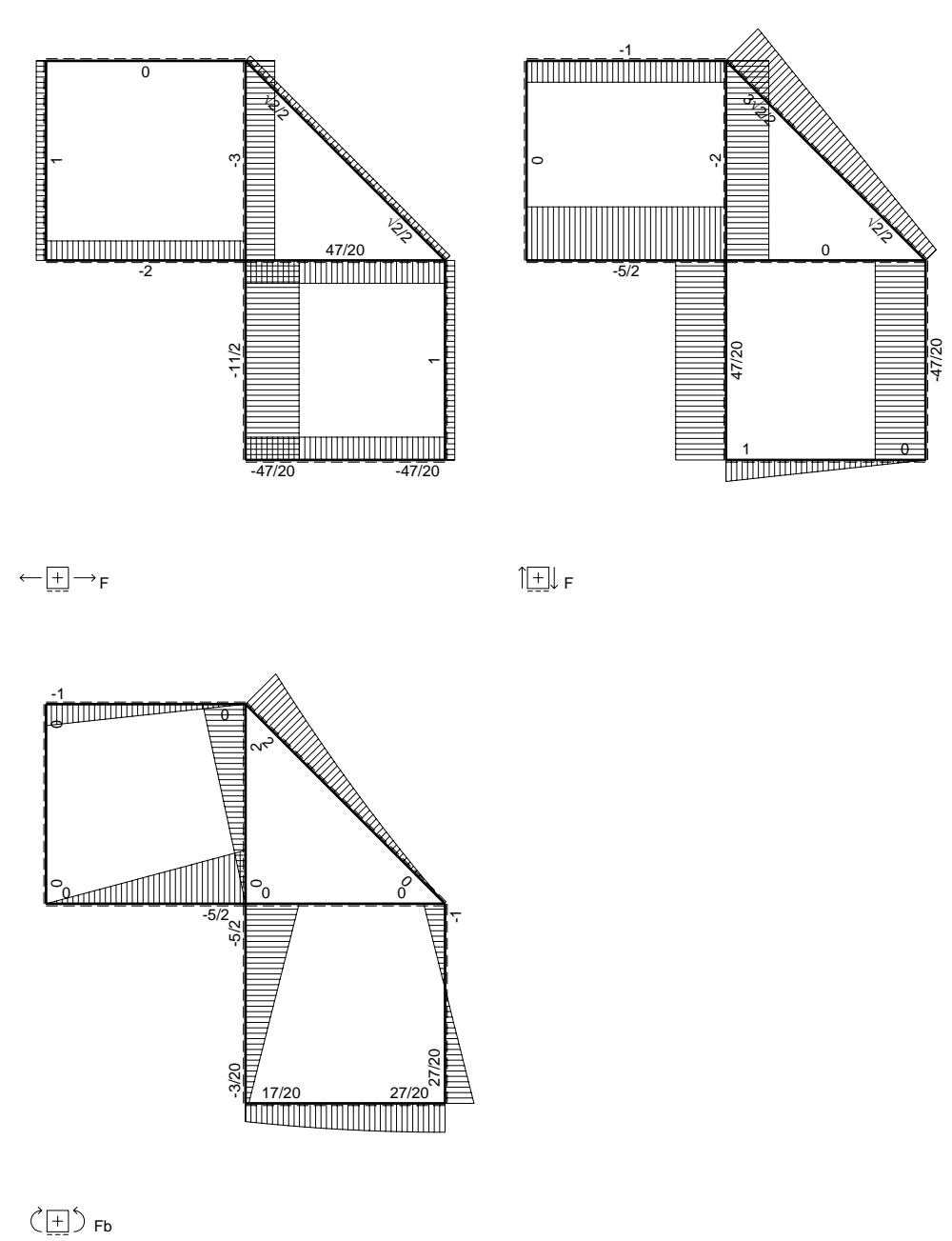
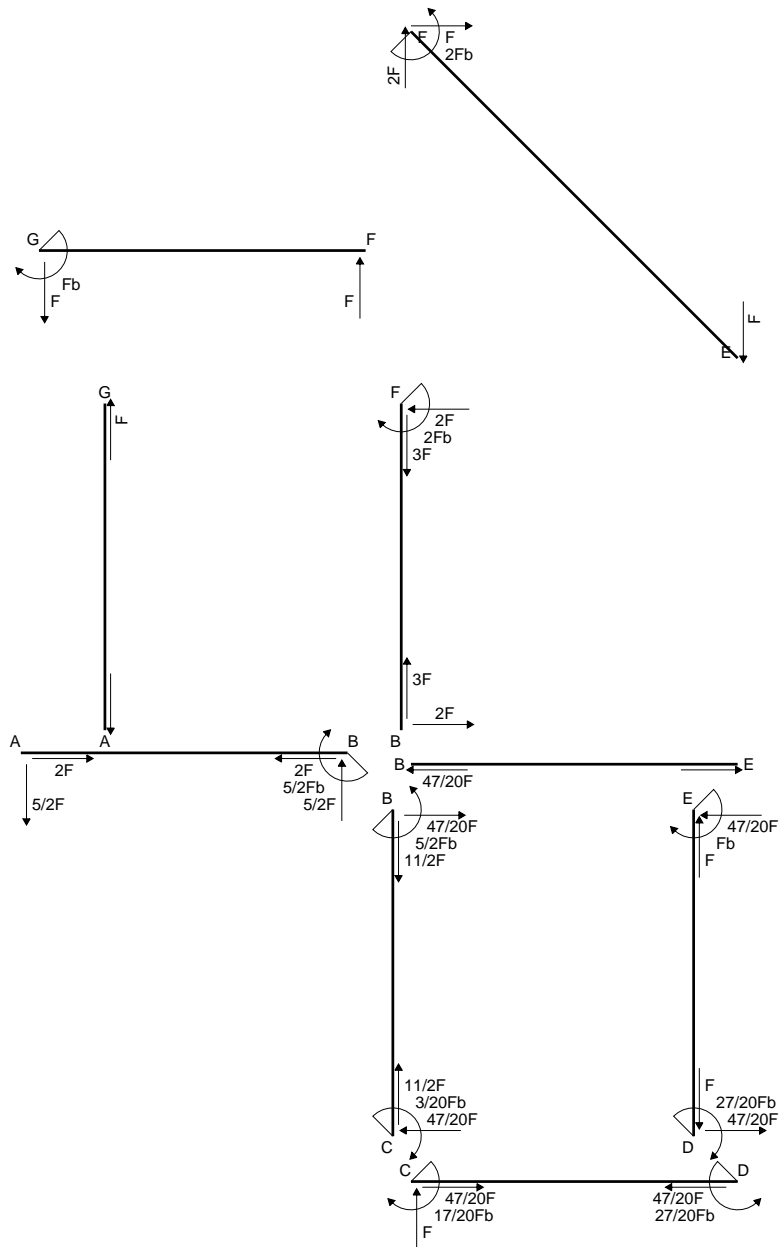

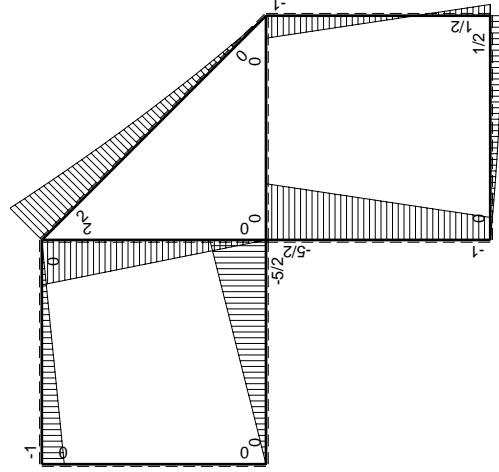
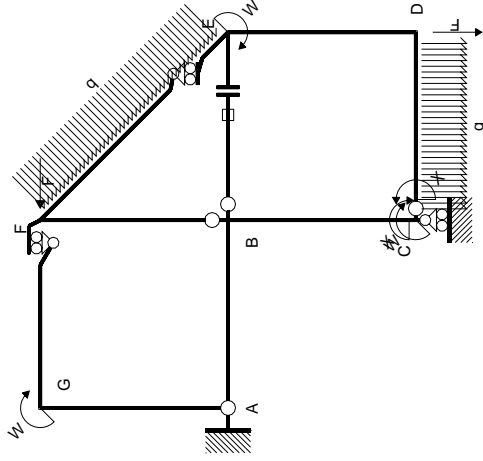

Schema di calcolo iperstatico

M_0 flessione da carichi assegnati

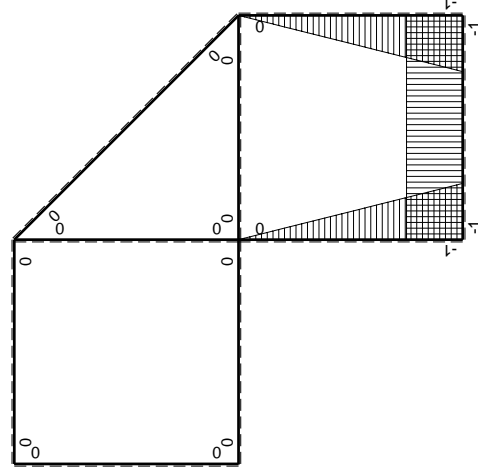

M_x flessione da iperstatica X=1

Quadro contribuiti PLV per iperstatica X=W_{CD}

→	$M_x(x)$	$M_0(x)$	$M_x M_0$	$M_x M_x$	$\int M_x M_0 / EJ dx$	$\int X M_x M_x / EJ dx$
AB b	0	-5/2Fx	0	0	0	0
BA b	0	5/2Fb-5/2Fx	0	0	0	0
BC b	-x/b	-5/2Fb+3/2Fx	5/2Fx-3/2Fx ² /b	x ² /b ²	3/4Fb ² /EJ	1/3Xb/EJ
CB b	1-x/b	Fb+3/2Fx	Fb+1/2Fx-3/2Fx ² /b	1-2x/b+x ² /b ²	-1/3Fb ² /EJ	Xb/EJ
CD b	-1	Fx-1/2qx ²	-Fx+1/2Fx ² /b	1	-1/3Fb ² /EJ	Xb/EJ
DC b	1	-1/2Fb+1/2qx ²	-1/2Fb+1/2Fx ² /b	1	-1/3Fb ² /EJ	Xb/EJ
DE b	-1+x/b	1/2Fb-3/2Fx	-1/2Fb+2Fx-3/2Fx ² /b	1-2x/b+x ² /b ²	0	1/3Xb/EJ
ED b	x/b	Fb-3/2Fx	Fx-3/2Fx ² /b	x ² /b ²	0	1/3Xb/EJ
EF √2b	0	√2/2Fx+1/2qx ²	0	0	0	0
FG b	0	-Fx	0	0	0	0
GF b	0	Fb-Fx	0	0	0	0
GA b	0	0	0	0	0	0
AG b	0	0	0	0	0	0
FB b	0	2Fb-2Fx	0	0	0	0
BF b	0	-2Fx	0	0	0	0
BE b	0	0	0	0	0	0
EB b	0	0	0	0	0	0
BE	elongazione asta $N_{1, BE} \epsilon_{BE} L_{BE}$				Fb ² /EJ	
	totali				17/12Fb ² /EJ	5/3Xb/EJ
	iperstatica X=W _{CD}				-17/20Fb	

Sviluppi di calcolo iperstatica

$$L_{BC}^{xx} = \int_0^b (x^2/b^2) 1/EJ dx = [1/3 x^3/b^2]_0^b 1/EJ$$

$$= (1/3 b) 1/EJ = 1/3 b/EJ$$

$$L_{CB}^{xx} = \int_0^b (1 - 2x/b + x^2/b^2) 1/EJ dx = [x - x^2/b + 1/3 x^3/b^2]_0^b 1/EJ$$

$$= (b - b + 1/3 b) 1/EJ = 1/3 b/EJ$$

$$L_{CD}^{xx} = \int_0^b (1) 1/EJ dx = [x]_0^b 1/EJ$$

$$= (b) 1/EJ = b/EJ$$

$$L_{DC}^{xx} = \int_0^b (1) 1/EJ dx = [x]_0^b 1/EJ$$

$$= (b) 1/EJ = b/EJ$$

$$L_{DE}^{xx} = \int_0^b (1 - 2x/b + x^2/b^2) 1/EJ dx = [x - x^2/b + 1/3 x^3/b^2]_0^b 1/EJ$$

$$= (b - b + 1/3 b) 1/EJ = 1/3 b/EJ$$

$$L_{ED}^{xx} = \int_0^b (x^2/b^2) 1/EJ dx = [1/3 x^3/b^2]_0^b 1/EJ$$

$$= (1/3 b) 1/EJ = 1/3 b/EJ$$

$$L_{BC}^{xo} = \int_0^b (5/2 x/b - 3/2 x^2/b^2) Fb 1/EJ dx = [5/4 x^2/b - 1/2 x^3/b^2]_0^b Fb 1/EJ$$

$$= (5/4 b - 1/2 b) Fb 1/EJ = 3/4 Fb^2/EJ$$

$$L_{CB}^{xo} = \int_0^b (1 + 1/2 x/b - 3/2 x^2/b^2) Fb 1/EJ dx = [x + 1/4 x^2/b - 1/2 x^3/b^2]_0^b Fb 1/EJ$$

$$= (b + 1/4 b - 1/2 b) Fb 1/EJ = 3/4 Fb^2/EJ$$

$$L_{CD}^{xo} = \int_0^b (-x/b + 1/2 x^2/b^2) Fb 1/EJ dx = [-1/2 x^2/b + 1/6 x^3/b^2]_0^b Fb 1/EJ$$

$$= (-1/2 b + 1/6 b) Fb 1/EJ = -1/3 Fb^2/EJ$$

$$L_{DC}^{xo} = \int_0^b (-1/2 + 1/2 x^2/b^2) Fb 1/EJ dx = [-1/2 x + 1/6 x^3/b^2]_0^b Fb 1/EJ$$

$$= (-1/2 b + 1/6 b) Fb 1/EJ = -1/3 Fb^2/EJ$$

$$L_{DE}^{xo} = \int_0^b (-1/2 + 2x/b - 3/2 x^2/b^2) Fb 1/EJ dx = [-1/2 x + x^2/b - 1/2 x^3/b^2]_0^b Fb 1/EJ$$

$$= (-1/2 b + b - 1/2 b) Fb 1/EJ = 0$$

$$L_{ED}^{xo} = \int_0^b (x/b - 3/2 x^2/b^2) Fb 1/EJ dx = [1/2 x^2/b - 1/2 x^3/b^2]_0^b Fb 1/EJ$$

$$= (1/2 b - 1/2 b) Fb 1/EJ = 0$$

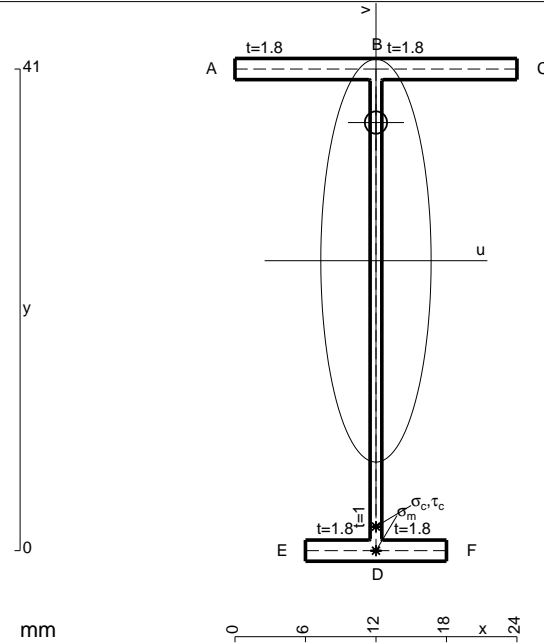

- A = 105.8 mm²
- J_u = 31122. mm⁴
- J_v = 2333. mm⁴
- J_I = 83.65 mm⁴
- y_o = 11.76 mm
- y_g = 24.69 mm
- N = -320. N
- T_y = -400. N
- M_x = -280000. Nmm
- x_m = 12. mm
- v_m = -24.69 mm
- σ_m = N/A-Mv/J_u = -225.1 N/mm²
- y_c = 3. mm
- u_c = -12. mm
- v_c = -21.69 mm
- σ_c = N/A-Mv/J_u = -225.1 N/mm²
- τ_c = TS'/tJ_u = 6.853 N/mm²
- τ_g = TS'/tJ_u = 6.853 N/mm²
- t_c = 160. mm
- σ_o = √σ²+3τ² = 225.4 N/mm²

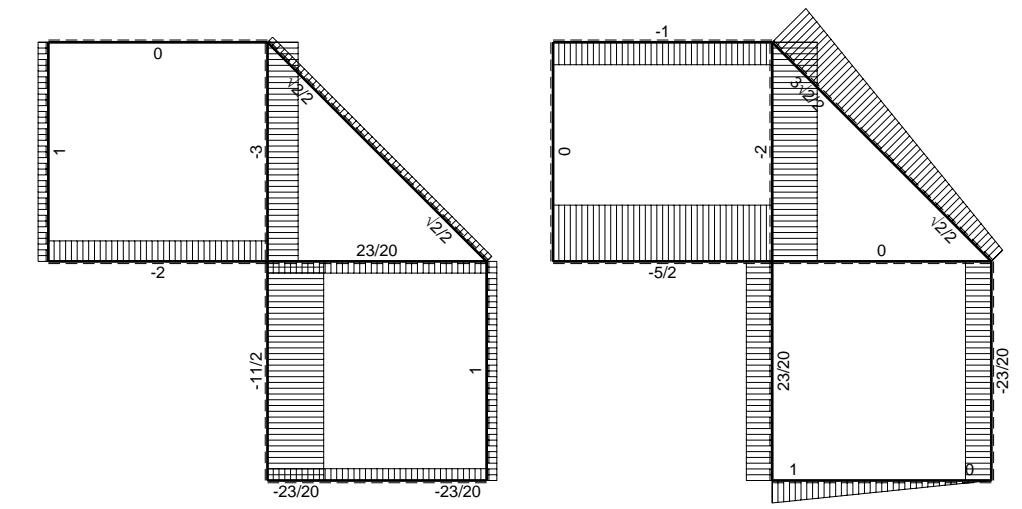
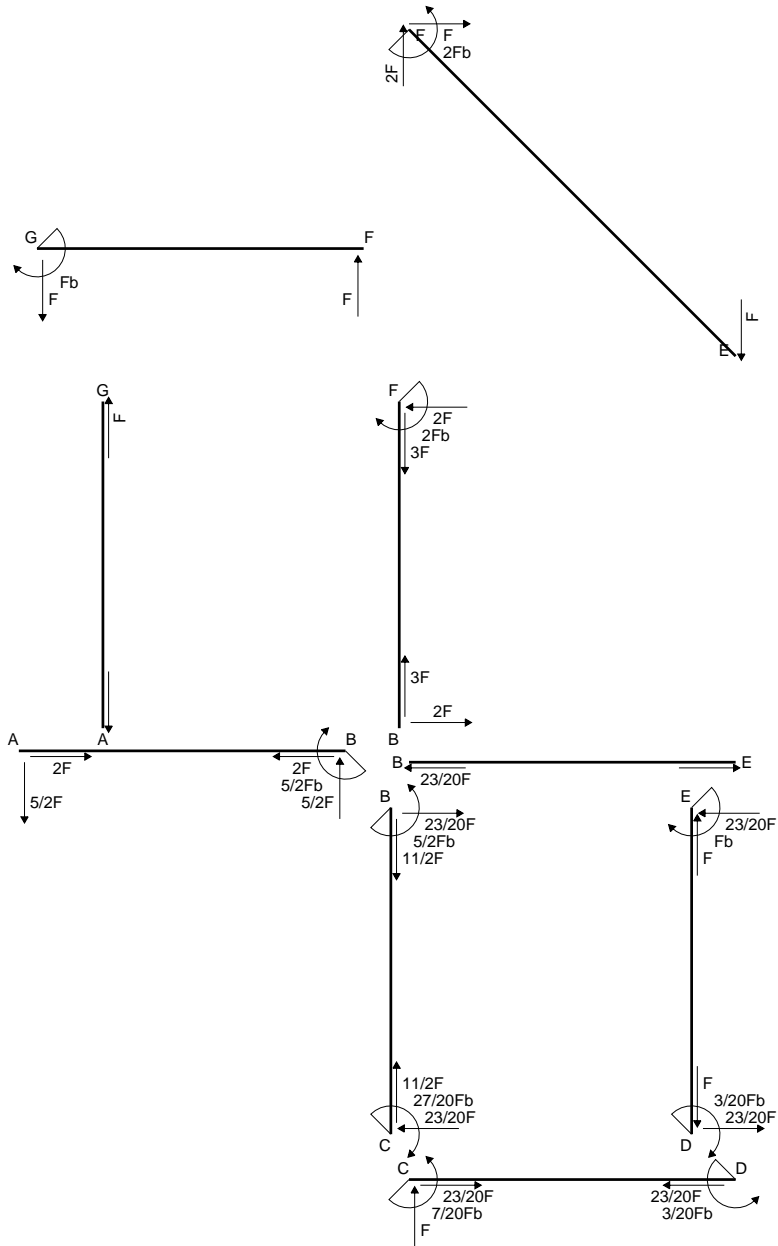

← (+) → F

↑ (+) ↓ F

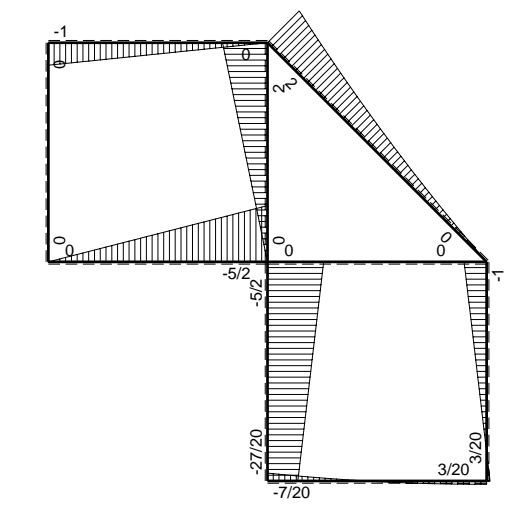

⊙ (+) ⊙ F_b

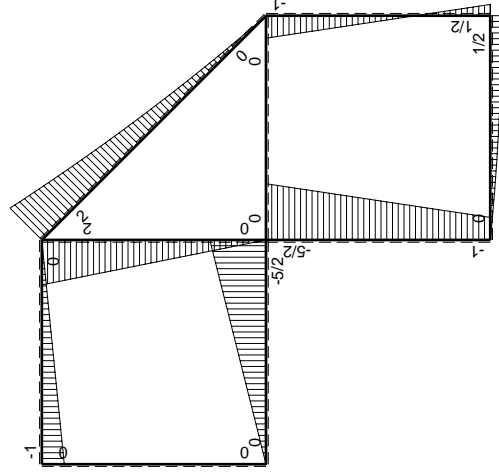
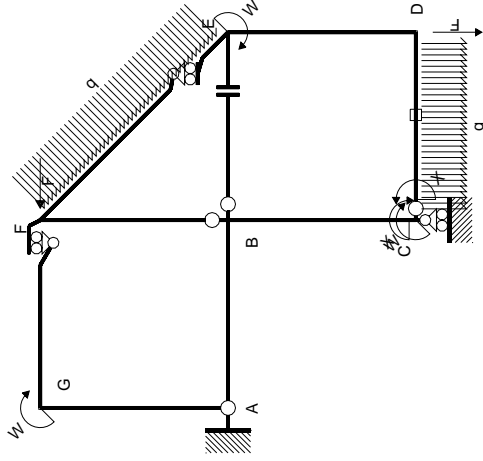

Schema di calcolo iperstatico

M_0 flessione da carichi assegnati

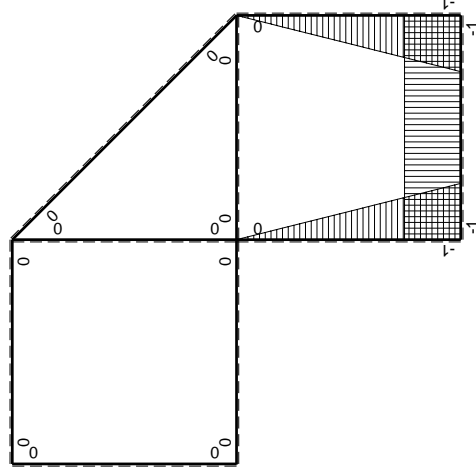

M_x flessione da iperstatica $X=1$

Quadro contribuiti PLV per iperstatica $X=W_{cd}$

\rightarrow	$M_x(x)$	$M_0(x)$	$M_x M_0$	$M_x M_x$	$\int M_x M_0 / EJ dx$	$\int X M_x M_x / EJ dx$
AB b	0	-5/2Fx	0	0	0	0
BA b	0	5/2Fb-5/2Fx	0	0	0	0
BC b	-x/b	-5/2Fb+3/2Fx	5/2Fx-3/2Fx ² /b	x ² /b ²	3/4Fb ² /EJ	1/3Xb/EJ
CB b	1-x/b	Fb+3/2Fx	Fb+1/2Fx-3/2Fx ² /b	1-2x/b+x ² /b ²	-1/3Fb ² /EJ	Xb/EJ
CD b	-1	Fx-1/2qx ²	-Fx+1/2Fx ² /b	1	-1/3Fb ² /EJ	Xb/EJ
DC b	1	-1/2Fb+1/2qx ²	-1/2Fb+1/2Fx ² /b	1	-1/3Fb ² /EJ	Xb/EJ
DE b	-1+x/b	1/2Fb-3/2Fx	-1/2Fb+2Fx-3/2Fx ² /b	1-2x/b+x ² /b ²	0	1/3Xb/EJ
ED b	x/b	Fb-3/2Fx	Fx-3/2Fx ² /b	x ² /b ²	0	1/3Xb/EJ
EF $\sqrt{2}b$	0	$\sqrt{2}/2Fx+1/2qx^2$	0	0	0	0
FG b	0	-Fx	0	0	0	0
GF b	0	Fb-Fx	0	0	0	0
GA b	0	0	0	0	0	0
AG b	0	0	0	0	0	0
FB b	0	2Fb-2Fx	0	0	0	0
BF b	0	-2Fx	0	0	0	0
BE b	0	0	0	0	0	0
EB b	0	0	0	0	0	0
CD	elongazione asta $N_{1,cd} \epsilon_{cd} L_{cd}$				-Fb ² /EJ	
	totali				-7/12Fb ² /EJ	5/3Xb/EJ
	iperstatica $X=W_{cd}$				7/20Fb	

Sviluppi di calcolo iperstatica

$$L_{BC}^{xx} = \int_0^b (x^2/b^2) 1/EJ dx = [1/3 x^3/b^2]_0^b 1/EJ$$

$$= (1/3 b) 1/EJ = 1/3 b/EJ$$

$$L_{CB}^{xx} = \int_0^b (1 - 2x/b + x^2/b^2) 1/EJ dx = [x - x^2/b + 1/3 x^3/b^2]_0^b 1/EJ$$

$$= (b - b + 1/3 b) 1/EJ = 1/3 b/EJ$$

$$L_{CD}^{xx} = \int_0^b (1) 1/EJ dx = [x]_0^b 1/EJ$$

$$= (b) 1/EJ = b/EJ$$

$$L_{DC}^{xx} = \int_0^b (1) 1/EJ dx = [x]_0^b 1/EJ$$

$$= (b) 1/EJ = b/EJ$$

$$L_{DE}^{xx} = \int_0^b (1 - 2x/b + x^2/b^2) 1/EJ dx = [x - x^2/b + 1/3 x^3/b^2]_0^b 1/EJ$$

$$= (b - b + 1/3 b) 1/EJ = 1/3 b/EJ$$

$$L_{ED}^{xx} = \int_0^b (x^2/b^2) 1/EJ dx = [1/3 x^3/b^2]_0^b 1/EJ$$

$$= (1/3 b) 1/EJ = 1/3 b/EJ$$

$$L_{BC}^{xo} = \int_0^b (5/2 x/b - 3/2 x^2/b^2) Fb 1/EJ dx = [5/4 x^2/b - 1/2 x^3/b^2]_0^b Fb 1/EJ$$

$$= (5/4 b - 1/2 b) Fb 1/EJ = 3/4 Fb^2/EJ$$

$$L_{CB}^{xo} = \int_0^b (1 + 1/2 x/b - 3/2 x^2/b^2) Fb 1/EJ dx = [x + 1/4 x^2/b - 1/2 x^3/b^2]_0^b Fb 1/EJ$$

$$= (b + 1/4 b - 1/2 b) Fb 1/EJ = 3/4 Fb^2/EJ$$

$$L_{CD}^{xo} = \int_0^b (-x/b + 1/2 x^2/b^2) Fb 1/EJ dx + 1 (-1) 1 Fb^2/EJ$$

$$= [-1/2 x^2/b + 1/6 x^3/b^2]_0^b Fb 1/EJ + 1 (-1) 1 Fb^2/EJ$$

$$= (-1/2 b + 1/6 b) Fb 1/EJ + 1 (-1) 1 Fb^2/EJ = -4/3 Fb^2/EJ$$

$$L_{DC}^{xo} = \int_0^b (-1/2 + 1/2 x^2/b^2) Fb 1/EJ dx + 1 (-1) 1 Fb^2/EJ$$

$$= [-1/2 x + 1/6 x^3/b^2]_0^b Fb 1/EJ + 1 (-1) 1 Fb^2/EJ$$

$$= (-1/2 b + 1/6 b) Fb 1/EJ + 1 (-1) 1 Fb^2/EJ = -4/3 Fb^2/EJ$$

$$L_{DE}^{xo} = \int_0^b (-1/2 + 2x/b - 3/2 x^2/b^2) Fb 1/EJ dx = [-1/2 x + x^2/b - 1/2 x^3/b^2]_0^b Fb 1/EJ$$

$$= (-1/2 b + b - 1/2 b) Fb 1/EJ = 0$$

$$L_{ED}^{xo} = \int_0^b (x/b - 3/2 x^2/b^2) Fb 1/EJ dx = [1/2 x^2/b - 1/2 x^3/b^2]_0^b Fb 1/EJ$$

$$= (1/2 b - 1/2 b) Fb 1/EJ = 0$$

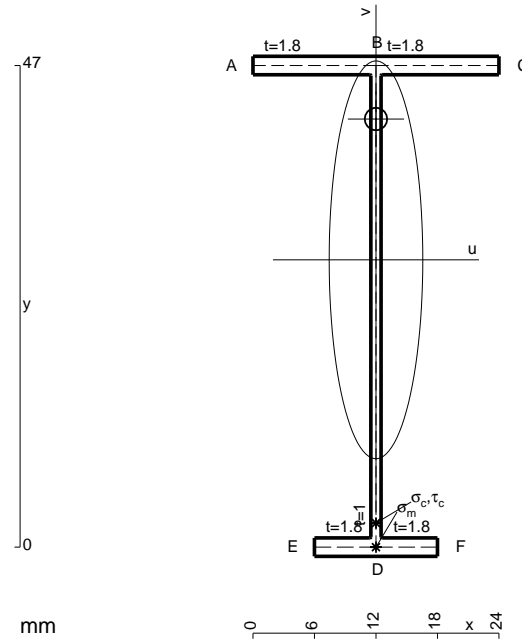

$$A = 111.8 \text{ mm}^2$$

$$J_u = 42133. \text{ mm}^4$$

$$J_v = 2333. \text{ mm}^4$$

$$J_t = 85.65 \text{ mm}^4$$

$$y_o = 13.74 \text{ mm}$$

$$y_g = 28.04 \text{ mm}$$

$$N = -340. \text{ N}$$

$$T_y = -425. \text{ N}$$

$$M_x = -352750. \text{ Nmm}$$

$$x_m = 12. \text{ mm}$$

$$v_m = -28.04 \text{ mm}$$

$$\sigma_m = N/A - Mv/J_u = -237.8 \text{ N/mm}^2$$

$$y_c = 3. \text{ mm}$$

$$u_c = -12. \text{ mm}$$

$$v_c = -25.04 \text{ mm}$$

$$\sigma_c = N/A - Mv/J_u = -237.8 \text{ N/mm}^2$$

$$\tau_c = TS/tJ_u = 6.109 \text{ N/mm}^2$$

$$\tau_g = TS/tJ_u = 6.109 \text{ N/mm}^2$$

$$t_c = 170. \text{ mm}$$

$$\sigma_o = \sqrt{\sigma^2 + 3\tau^2} = 238. \text{ N/mm}^2$$

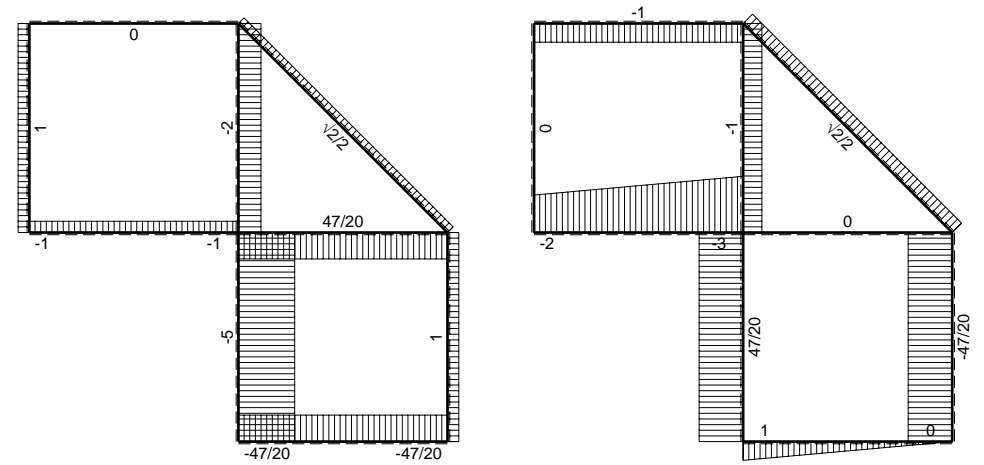
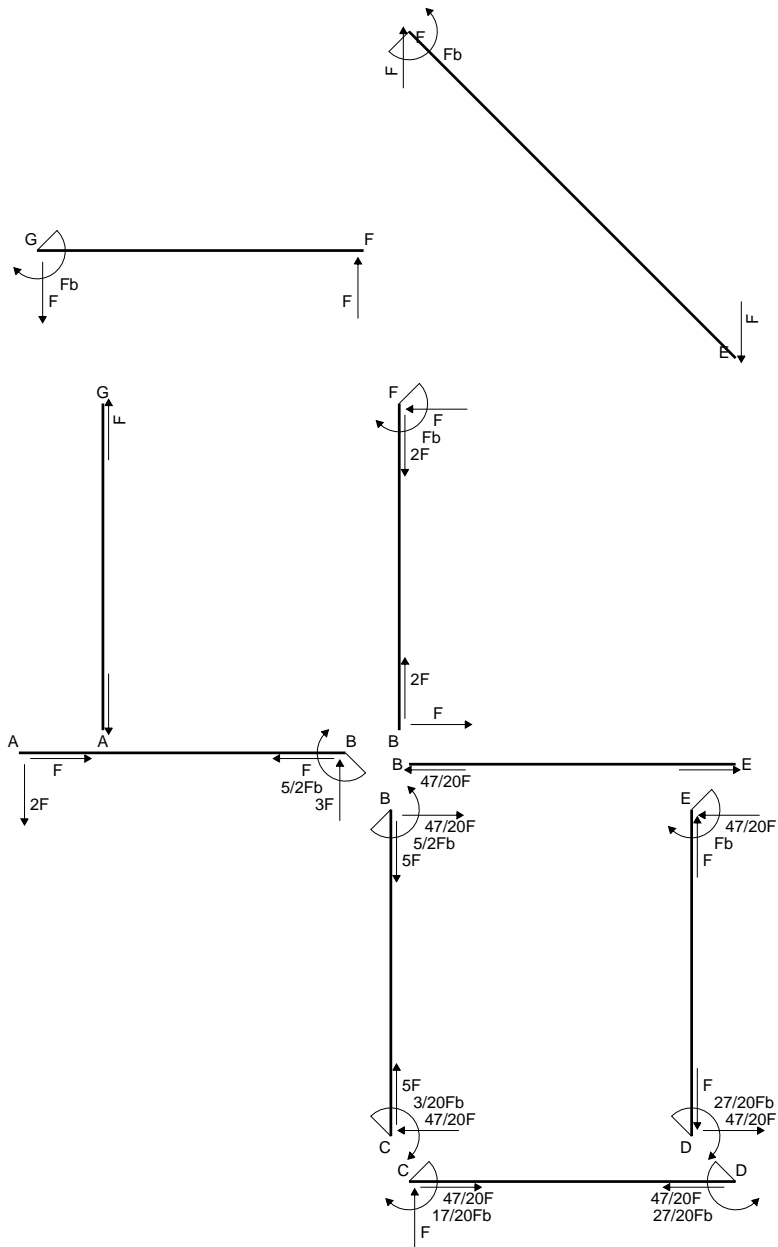

← ⊕ → F

↑ ⊕ ↓ F

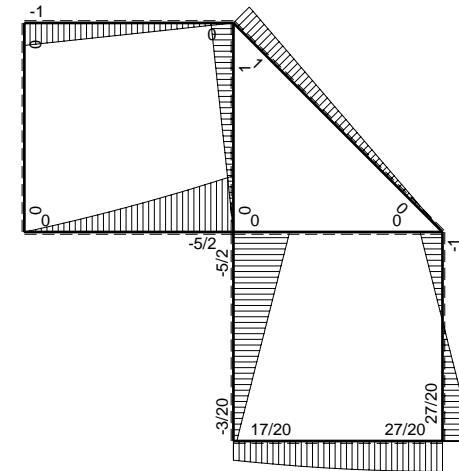

⊕ ⊖ F_b

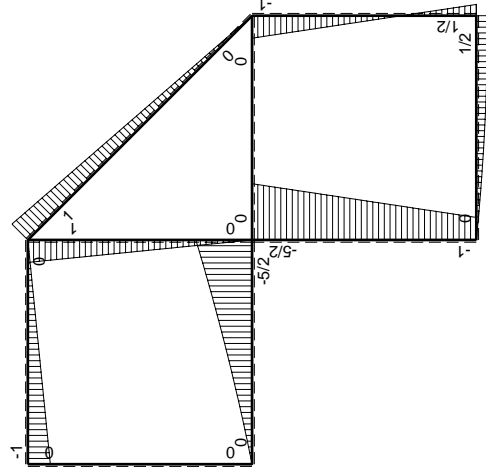
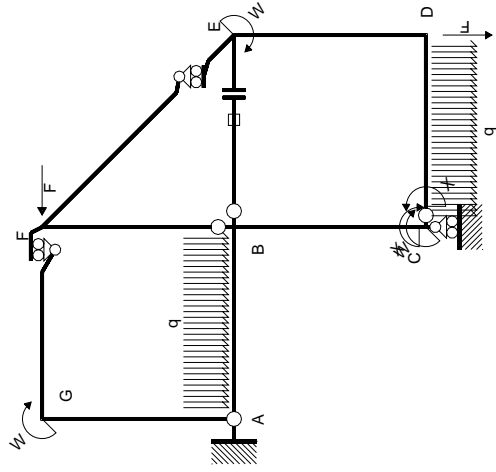

Schema di calcolo iperstatico

M_0 flessione da carichi assegnati

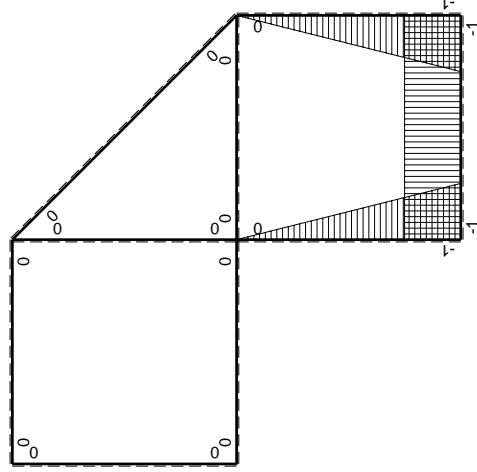

M_x flessione da iperstatica X=1

Quadro contributi PLV per iperstatica X=W_{cd}

→	$M_x(x)$	$M_0(x)$	$M_x M_0$	$M_x M_x$	$\int M_x M_0 / EJ dx$	$\int X M_x M_x / EJ dx$
AB b	0	$-2Fx - 1/2qx^2$	0	0	0	0
BA b	0	$5/2Fb - 3Fx + 1/2qx^2$	0	0	0	0
BC b	$-x/b$	$-5/2Fb + 3/2Fx$	$5/2Fx - 3/2Fx^2/b$	x^2/b^2	$3/4Fb^2/EJ$	$1/3Xb/EJ$
CB b	$1-x/b$	$Fb + 3/2Fx$	$Fb + 1/2Fx - 3/2Fx^2/b$	$1 - 2x/b + x^2/b^2$	$-1/3Fb^2/EJ$	Xb/EJ
CD b	-1	$Fx - 1/2qx^2$	$-Fx + 1/2Fx^2/b$	1		
DC b	1	$-1/2Fb + 1/2qx^2$	$-1/2Fb + 1/2Fx^2/b$	1		
DE b	$-1 + x/b$	$1/2Fb - 3/2Fx$	$-1/2Fb + 2Fx - 3/2Fx^2/b$	$1 - 2x/b + x^2/b^2$	0	$1/3Xb/EJ$
ED b	x/b	$Fb - 3/2Fx$	$Fx - 3/2Fx^2/b$	x^2/b^2	0	0
EF $\sqrt{2}b$	0	$\sqrt{2}/2Fx$	0	0	0	0
FG b	0	-Fx	0	0	0	0
GF b	0	$Fb - Fx$	0	0	0	0
GA b	0	0	0	0	0	0
AG b	0	0	0	0	0	0
FB b	0	$Fb - Fx$	0	0	0	0
BF b	0	-Fx	0	0	0	0
BE b	0	0	0	0	0	0
EB b	0	0	0	0	0	0
BE	elongazione asta $N_{1, BE} \epsilon_{BE} L_{BE}$				Fb^2/EJ	
	totali				$17/12Fb^2/EJ$	$5/3Xb/EJ$
	iperstatica X=W _{cd}				$-17/20Fb$	

Sviluppi di calcolo iperstatica

$$L_{BC}^{xx} = \int_0^b (x^2/b^2) 1/EJ dx = [1/3 x^3/b^2]_0^b 1/EJ$$

$$= (1/3 b) 1/EJ = 1/3 b/EJ$$

$$L_{CB}^{xx} = \int_0^b (1 - 2x/b + x^2/b^2) 1/EJ dx = [x - x^2/b + 1/3 x^3/b^2]_0^b 1/EJ$$

$$= (b - b + 1/3 b) 1/EJ = 1/3 b/EJ$$

$$L_{CD}^{xx} = \int_0^b (1) 1/EJ dx = [x]_0^b 1/EJ$$

$$= (b) 1/EJ = b/EJ$$

$$L_{DC}^{xx} = \int_0^b (1) 1/EJ dx = [x]_0^b 1/EJ$$

$$= (b) 1/EJ = b/EJ$$

$$L_{DE}^{xx} = \int_0^b (1 - 2x/b + x^2/b^2) 1/EJ dx = [x - x^2/b + 1/3 x^3/b^2]_0^b 1/EJ$$

$$= (b - b + 1/3 b) 1/EJ = 1/3 b/EJ$$

$$L_{ED}^{xx} = \int_0^b (x^2/b^2) 1/EJ dx = [1/3 x^3/b^2]_0^b 1/EJ$$

$$= (1/3 b) 1/EJ = 1/3 b/EJ$$

$$L_{BC}^{xo} = \int_0^b (5/2 x/b - 3/2 x^2/b^2) Fb 1/EJ dx = [5/4 x^2/b - 1/2 x^3/b^2]_0^b Fb 1/EJ$$

$$= (5/4 b - 1/2 b) Fb 1/EJ = 3/4 Fb^2/EJ$$

$$L_{CB}^{xo} = \int_0^b (1 + 1/2 x/b - 3/2 x^2/b^2) Fb 1/EJ dx = [x + 1/4 x^2/b - 1/2 x^3/b^2]_0^b Fb 1/EJ$$

$$= (b + 1/4 b - 1/2 b) Fb 1/EJ = 3/4 Fb^2/EJ$$

$$L_{CD}^{xo} = \int_0^b (-x/b + 1/2 x^2/b^2) Fb 1/EJ dx = [-1/2 x^2/b + 1/6 x^3/b^2]_0^b Fb 1/EJ$$

$$= (-1/2 b + 1/6 b) Fb 1/EJ = -1/3 Fb^2/EJ$$

$$L_{DC}^{xo} = \int_0^b (-1/2 + 1/2 x^2/b^2) Fb 1/EJ dx = [-1/2 x + 1/6 x^3/b^2]_0^b Fb 1/EJ$$

$$= (-1/2 b + 1/6 b) Fb 1/EJ = -1/3 Fb^2/EJ$$

$$L_{DE}^{xo} = \int_0^b (-1/2 + 2x/b - 3/2 x^2/b^2) Fb 1/EJ dx = [-1/2 x + x^2/b - 1/2 x^3/b^2]_0^b Fb 1/EJ$$

$$= (-1/2 b + b - 1/2 b) Fb 1/EJ = 0$$

$$L_{ED}^{xo} = \int_0^b (x/b - 3/2 x^2/b^2) Fb 1/EJ dx = [1/2 x^2/b - 1/2 x^3/b^2]_0^b Fb 1/EJ$$

$$= (1/2 b - 1/2 b) Fb 1/EJ = 0$$

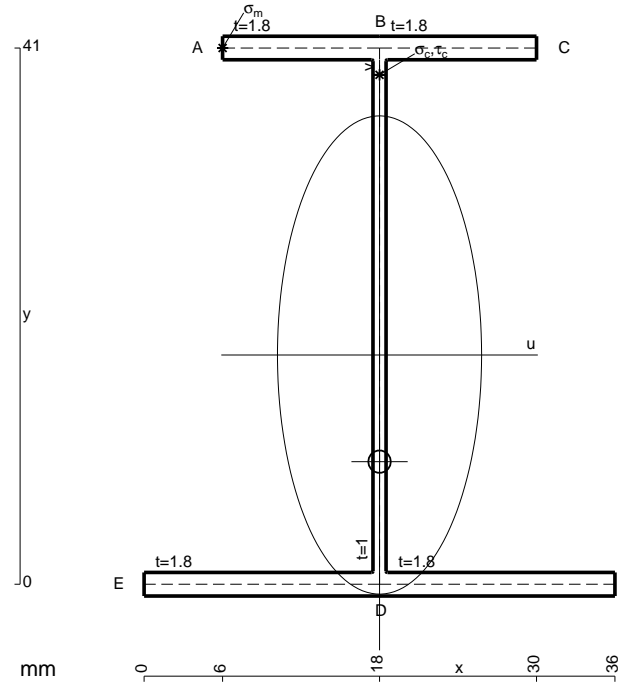

- A = 149. mm²
- J_u = 49815. mm⁴
- J_v = 9072. mm⁴
- J_t = 130.3 mm⁴
- y_o = -8.157 mm
- y_g = 17.53 mm
- N = -440. N
- T_y = -1320. N
- M_x = -429000. Nmm
- x_m = 6. mm
- y_m = 41. mm
- u_m = -12. mm
- v_m = 23.47 mm
- σ_m = N/A - Mv/J_u = 199.2 N/mm²
- x_c = 18. mm
- y_c = 41. mm
- v_c = 23.47 mm
- σ_c = N/A - Mv/J_u = 199.2 N/mm²
- τ_c = TS_y/tJ_u = 26.87 N/mm²
- τ_g = TS_y/tJ_u = 26.87 N/mm²
- t_c = 440. mm
- σ_o = √σ² + 3τ² = 204.5 N/mm²

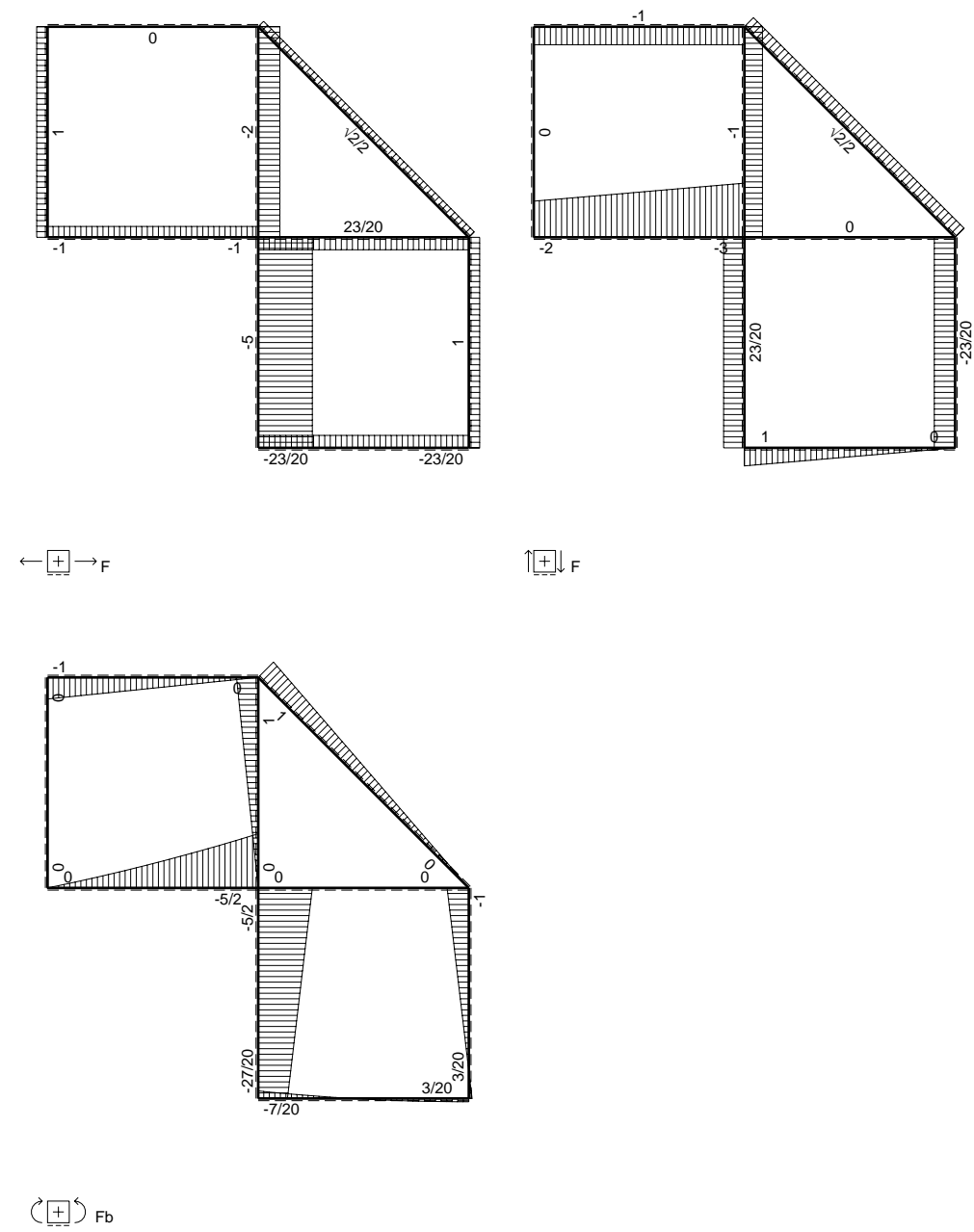
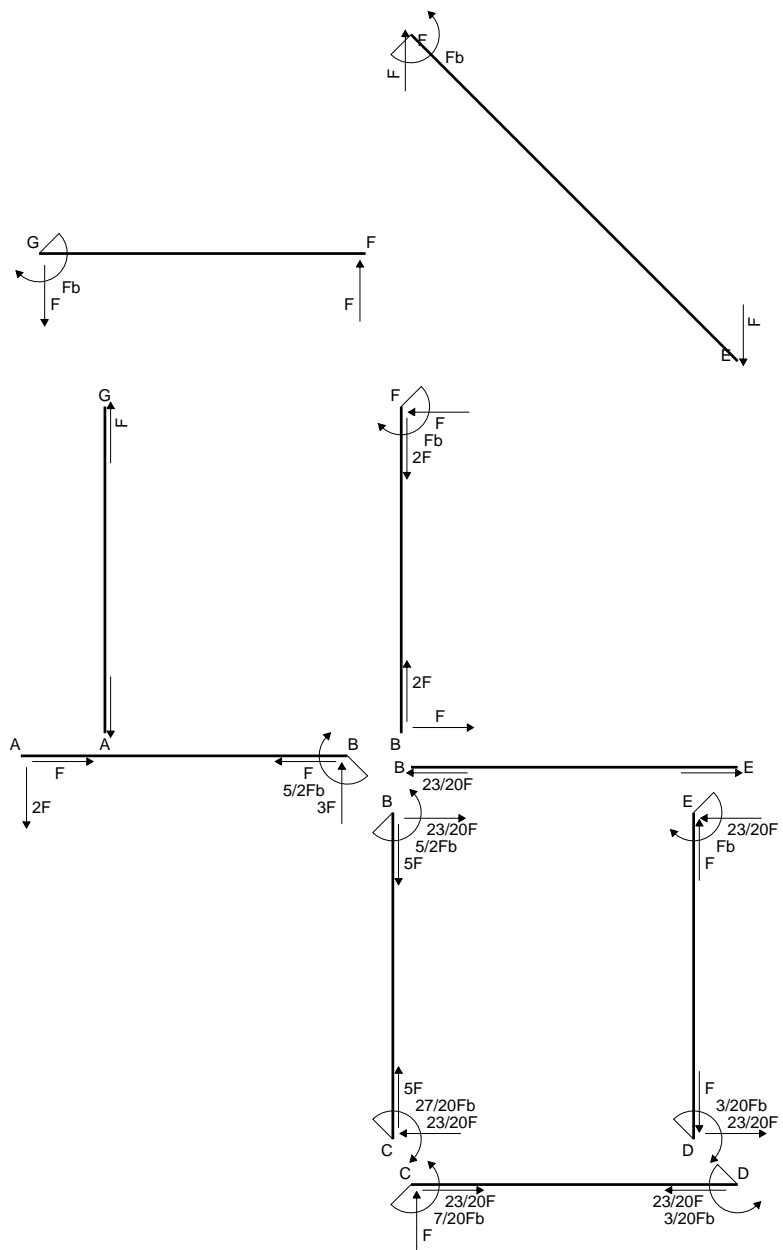

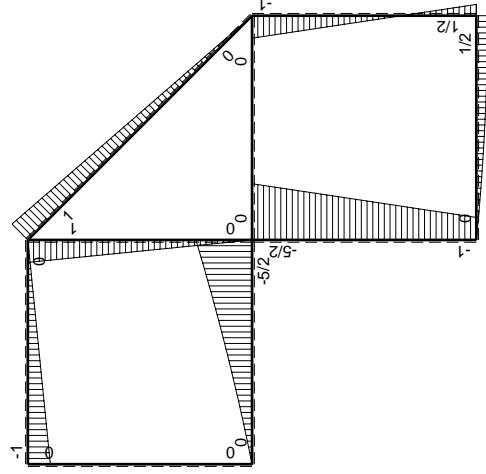
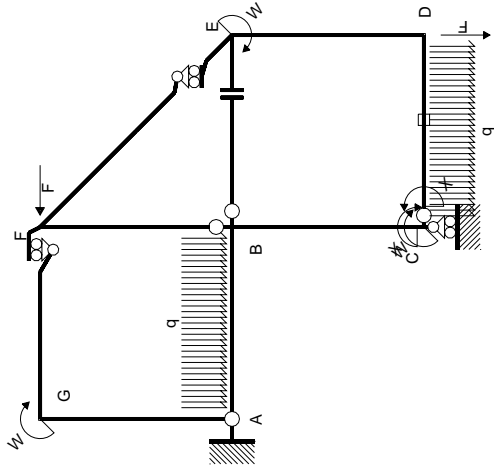

Schema di calcolo iperstatico

M_0 flessione da carichi assegnati

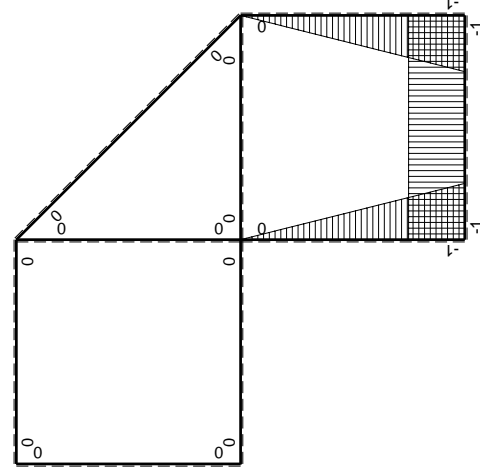

M_x flessione da iperstatica X=1

Quadro contributi PLV per iperstatica X=W_{CD}

→	$M_x(x)$	$M_0(x)$	$M_x M_0$	$M_x M_x$	$\int M_x M_0 / EJ dx$	$\int M_x M_x / EJ dx$
AB b	0	$-2Fx - 1/2qx^2$	0	0	0	0
BA b	0	$5/2Fb - 3Fx + 1/2qx^2$	0	0	0	0
BC b	$-x/b$	$-5/2Fb + 3/2Fx$	$5/2Fx - 3/2Fx^2/b$	x^2/b^2	$3/4Fb^2/EJ$	$1/3Xb/EJ$
CB b	$1-x/b$	$Fb + 3/2Fx$	$Fb + 1/2Fx - 3/2Fx^2/b$	$1 - 2x/b + x^2/b^2$	$-1/3Fb^2/EJ$	Xb/EJ
CD b	-1	$Fx - 1/2qx^2$	$-Fx + 1/2Fx^2/b$	1		
DC b	1	$-1/2Fb + 1/2qx^2$	$-1/2Fb + 1/2Fx^2/b$	1		
DE b	$-1 + x/b$	$1/2Fb - 3/2Fx$	$-1/2Fb + 2Fx - 3/2Fx^2/b$	$1 - 2x/b + x^2/b^2$	0	$1/3Xb/EJ$
ED b	x/b	$Fb - 3/2Fx$	$Fx - 3/2Fx^2/b$	x^2/b^2	0	0
EF $\sqrt{2}b$	0	$\sqrt{2}/2Fx$	0	0	0	0
FG b	0	-Fx	0	0	0	0
GF b	0	$Fb - Fx$	0	0	0	0
GA b	0	0	0	0	0	0
AG b	0	0	0	0	0	0
FB b	0	$Fb - Fx$	0	0	0	0
BF b	0	-Fx	0	0	0	0
BE b	0	0	0	0	0	0
EB b	0	0	0	0	0	0
CD	elongazione asta $N_{1,CD} \epsilon_{CD} L_{CD}$				$-Fb^2/EJ$	
	totali				$-7/12Fb^2/EJ$	$5/3Xb/EJ$
	iperstatica X=W _{CD}				$7/20Fb$	

Sviluppi di calcolo iperstatica

$$L_{BC}^{xx} = \int_0^b (x^2/b^2) 1/EJ dx = [1/3 x^3/b^2]_0^b 1/EJ$$

$$= (1/3 b) 1/EJ = 1/3 b/EJ$$

$$L_{CB}^{xx} = \int_0^b (1 - 2x/b + x^2/b^2) 1/EJ dx = [x - x^2/b + 1/3 x^3/b^2]_0^b 1/EJ$$

$$= (b - b + 1/3 b) 1/EJ = 1/3 b/EJ$$

$$L_{CD}^{xx} = \int_0^b (1) 1/EJ dx = [x]_0^b 1/EJ$$

$$= (b) 1/EJ = b/EJ$$

$$L_{DC}^{xx} = \int_0^b (1) 1/EJ dx = [x]_0^b 1/EJ$$

$$= (b) 1/EJ = b/EJ$$

$$L_{DE}^{xx} = \int_0^b (1 - 2x/b + x^2/b^2) 1/EJ dx = [x - x^2/b + 1/3 x^3/b^2]_0^b 1/EJ$$

$$= (b - b + 1/3 b) 1/EJ = 1/3 b/EJ$$

$$L_{ED}^{xx} = \int_0^b (x^2/b^2) 1/EJ dx = [1/3 x^3/b^2]_0^b 1/EJ$$

$$= (1/3 b) 1/EJ = 1/3 b/EJ$$

$$L_{BC}^{xo} = \int_0^b (5/2 x/b - 3/2 x^2/b^2) Fb 1/EJ dx = [5/4 x^2/b - 1/2 x^3/b^2]_0^b Fb 1/EJ$$

$$= (5/4 b - 1/2 b) Fb 1/EJ = 3/4 Fb^2/EJ$$

$$L_{CB}^{xo} = \int_0^b (1 + 1/2 x/b - 3/2 x^2/b^2) Fb 1/EJ dx = [x + 1/4 x^2/b - 1/2 x^3/b^2]_0^b Fb 1/EJ$$

$$= (b + 1/4 b - 1/2 b) Fb 1/EJ = 3/4 Fb^2/EJ$$

$$L_{CD}^{xo} = \int_0^b (-x/b + 1/2 x^2/b^2) Fb 1/EJ dx + 1 (-1) 1 Fb^2/EJ$$

$$= [-1/2 x^2/b + 1/6 x^3/b^2]_0^b Fb 1/EJ + 1 (-1) 1 Fb^2/EJ$$

$$= (-1/2 b + 1/6 b) Fb 1/EJ + 1 (-1) 1 Fb^2/EJ = -4/3 Fb^2/EJ$$

$$L_{DC}^{xo} = \int_0^b (-1/2 + 1/2 x^2/b^2) Fb 1/EJ dx + 1 (-1) 1 Fb^2/EJ$$

$$= [-1/2 x + 1/6 x^3/b^2]_0^b Fb 1/EJ + 1 (-1) 1 Fb^2/EJ$$

$$= (-1/2 b + 1/6 b) Fb 1/EJ + 1 (-1) 1 Fb^2/EJ = -4/3 Fb^2/EJ$$

$$L_{DE}^{xo} = \int_0^b (-1/2 + 2x/b - 3/2 x^2/b^2) Fb 1/EJ dx = [-1/2 x + x^2/b - 1/2 x^3/b^2]_0^b Fb 1/EJ$$

$$= (-1/2 b + b - 1/2 b) Fb 1/EJ = 0$$

$$L_{ED}^{xo} = \int_0^b (x/b - 3/2 x^2/b^2) Fb 1/EJ dx = [1/2 x^2/b - 1/2 x^3/b^2]_0^b Fb 1/EJ$$

$$= (1/2 b - 1/2 b) Fb 1/EJ = 0$$

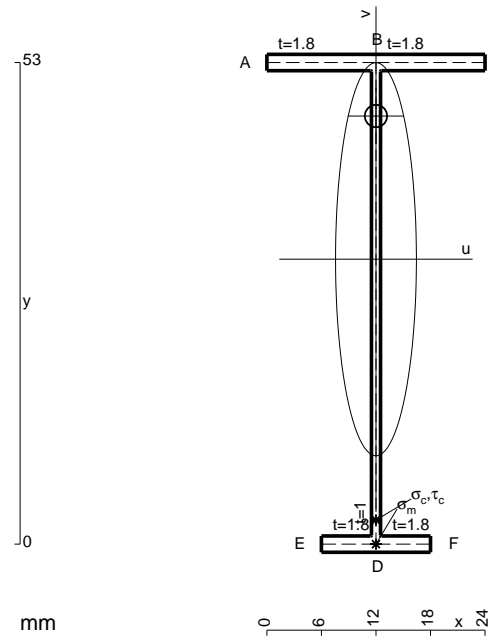

$$A = 117.8 \text{ mm}^2$$

$$J_u = 55131. \text{ mm}^4$$

$$J_v = 2333. \text{ mm}^4$$

$$J_t = 87.65 \text{ mm}^4$$

$$y_o = 15.75 \text{ mm}$$

$$y_g = 31.36 \text{ mm}$$

$$N = -260. \text{ N}$$

$$T_y = -780. \text{ N}$$

$$M_x = -357500. \text{ Nmm}$$

$$x_m = 12. \text{ mm}$$

$$v_m = -31.36 \text{ mm}$$

$$\sigma_m = N/A - Mv/J_u = -205.6 \text{ N/mm}^2$$

$$y_c = 3. \text{ mm}$$

$$u_c = -12. \text{ mm}$$

$$v_c = -28.36 \text{ mm}$$

$$\sigma_c = N/A - Mv/J_u = -205.6 \text{ N/mm}^2$$

$$\tau_c = TS/tJ_u = 9.583 \text{ N/mm}^2$$

$$\tau_g = TS/tJ_u = 9.583 \text{ N/mm}^2$$

$$t_c = 260. \text{ mm}$$

$$\sigma_o = \sqrt{\sigma^2 + 3\tau^2} = 206.2 \text{ N/mm}^2$$

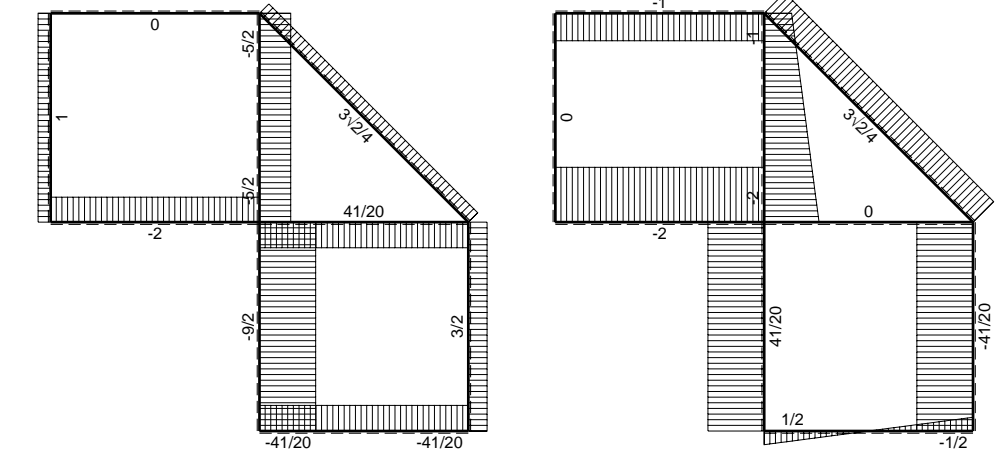
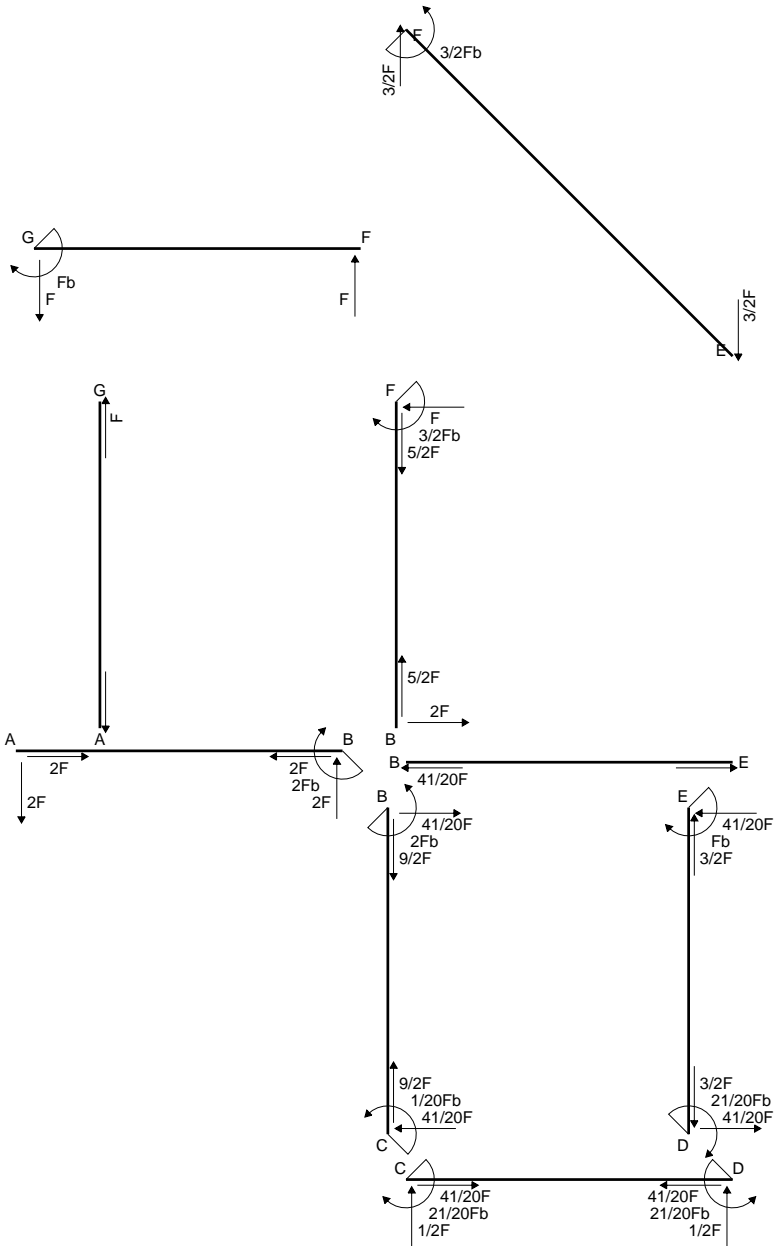

← ⊕ → F

↑ ⊕ ↓ F

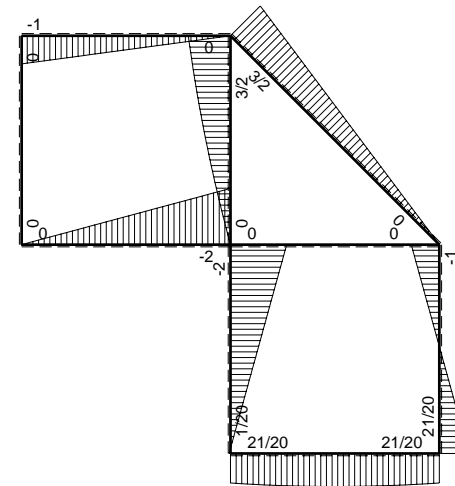

⊕ ⊖ F_b

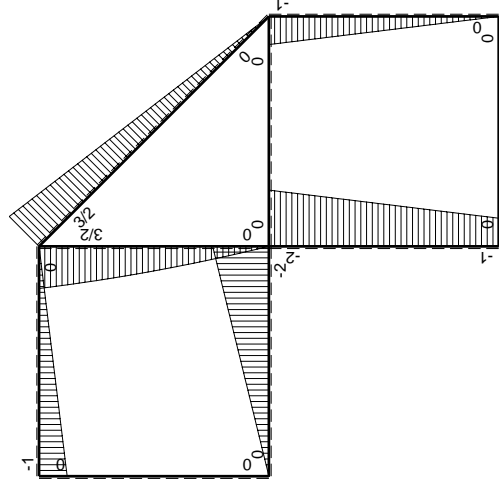
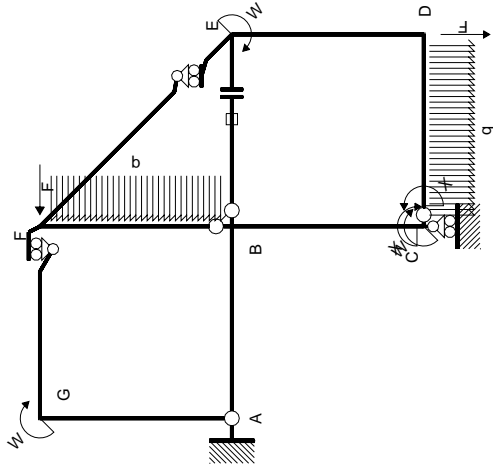

Schema di calcolo iperstatico

M_0 flessione da carichi assegnati

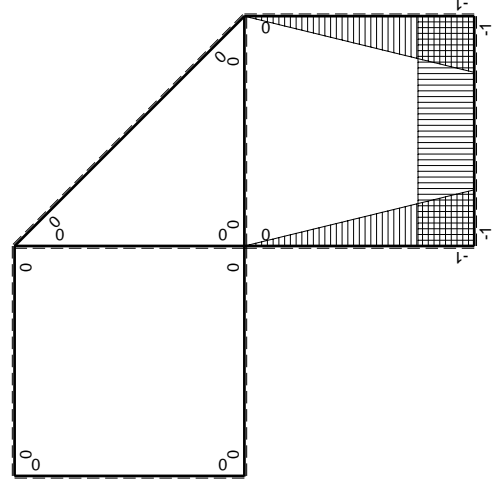

M_x flessione da iperstatica $X=1$

Quadro contribuiti PLV per iperstatica $X=W_{cd}$

\rightarrow	$M_x(x)$	$M_0(x)$	$M_x M_0$	$M_x M_x$	$\int M_x M_0 / EJ dx$	$\int X M_x M_x / EJ dx$
AB b	0	-2Fx	0	0	0	0
BA b	0	2Fb-2Fx	0	0	0	0
BC b	-x/b	-2Fb+Fx	2Fx-Fx ² /b	x ² /b ²	2/3Fb ² /EJ	1/3Xb/EJ
CB b	1-x/b	Fb+Fx	Fb-Fx ² /b	1-2x/b+x ² /b ²	2/3Fb ² /EJ	1/3Xb/EJ
CD b	-1	1/2Fx-1/2qx ²	-1/2Fx+1/2Fx ² /b	1	-1/12Fb ² /EJ	Xb/EJ
DC b	1	-1/2Fx+1/2qx ²	-1/2Fx+1/2Fx ² /b	1	-1/12Fb ² /EJ	Xb/EJ
DE b	-1+x/b	-Fx	Fx-Fx ² /b	1-2x/b+x ² /b ²	1/6Fb ² /EJ	1/3Xb/EJ
ED b	x/b	Fb-Fx	Fx-Fx ² /b	x ² /b ²	1/6Fb ² /EJ	1/3Xb/EJ
EF $\sqrt{2}b$	0	3\sqrt{2}/4Fx	0	0	0	0
FG b	0	-Fx	0	0	0	0
GF b	0	Fb-Fx	0	0	0	0
GA b	0	0	0	0	0	0
AG b	0	0	0	0	0	0
FB b	0	3/2Fb-Fx-1/2qx ²	0	0	0	0
BF b	0	-2Fx+1/2qx ²	0	0	0	0
BE b	0	0	0	0	0	0
EB b	0	0	0	0	0	0
BE	elongazione asta $N_{1, BE} \epsilon_{BE} = L_{BE}$				Fb ² /EJ	
	totali				7/4Fb ² /EJ	5/3Xb/EJ
	iperstatica $X=W_{cd}$				-21/20Fb	

Sviluppi di calcolo iperstatica

$$L_{BC}^{xx} = \int_0^b (x^2/b^2) 1/EJ dx = [1/3 x^3/b^2]_0^b 1/EJ$$

$$= (1/3 b) 1/EJ = 1/3 b/EJ$$

$$L_{CB}^{xx} = \int_0^b (1 - 2x/b + x^2/b^2) 1/EJ dx = [x - x^2/b + 1/3 x^3/b^2]_0^b 1/EJ$$

$$= (b - b + 1/3 b) 1/EJ = 1/3 b/EJ$$

$$L_{CD}^{xx} = \int_0^b (1) 1/EJ dx = [x]_0^b 1/EJ$$

$$= (b) 1/EJ = b/EJ$$

$$L_{DC}^{xx} = \int_0^b (1) 1/EJ dx = [x]_0^b 1/EJ$$

$$= (b) 1/EJ = b/EJ$$

$$L_{DE}^{xx} = \int_0^b (1 - 2x/b + x^2/b^2) 1/EJ dx = [x - x^2/b + 1/3 x^3/b^2]_0^b 1/EJ$$

$$= (b - b + 1/3 b) 1/EJ = 1/3 b/EJ$$

$$L_{ED}^{xx} = \int_0^b (x^2/b^2) 1/EJ dx = [1/3 x^3/b^2]_0^b 1/EJ$$

$$= (1/3 b) 1/EJ = 1/3 b/EJ$$

$$L_{BC}^{xo} = \int_0^b (2x/b - x^2/b^2) Fb 1/EJ dx = [x^2/b - 1/3 x^3/b^2]_0^b Fb 1/EJ$$

$$= (b - 1/3 b) Fb 1/EJ = 2/3 Fb^2/EJ$$

$$L_{CB}^{xo} = \int_0^b (1 - x^2/b^2) Fb 1/EJ dx = [x - 1/3 x^3/b^2]_0^b Fb 1/EJ$$

$$= (b - 1/3 b) Fb 1/EJ = 2/3 Fb^2/EJ$$

$$L_{CD}^{xo} = \int_0^b (-1/2 x/b + 1/2 x^2/b^2) Fb 1/EJ dx = [-1/4 x^2/b + 1/6 x^3/b^2]_0^b Fb 1/EJ$$

$$= (-1/4 b + 1/6 b) Fb 1/EJ = -1/12 Fb^2/EJ$$

$$L_{DC}^{xo} = \int_0^b (-1/2 x/b + 1/2 x^2/b^2) Fb 1/EJ dx = [-1/4 x^2/b + 1/6 x^3/b^2]_0^b Fb 1/EJ$$

$$= (-1/4 b + 1/6 b) Fb 1/EJ = -1/12 Fb^2/EJ$$

$$L_{DE}^{xo} = \int_0^b (x/b - x^2/b^2) Fb 1/EJ dx = [1/2 x^2/b - 1/3 x^3/b^2]_0^b Fb 1/EJ$$

$$= (1/2 b - 1/3 b) Fb 1/EJ = 1/6 Fb^2/EJ$$

$$L_{ED}^{xo} = \int_0^b (x/b - x^2/b^2) Fb 1/EJ dx = [1/2 x^2/b - 1/3 x^3/b^2]_0^b Fb 1/EJ$$

$$= (1/2 b - 1/3 b) Fb 1/EJ = 1/6 Fb^2/EJ$$

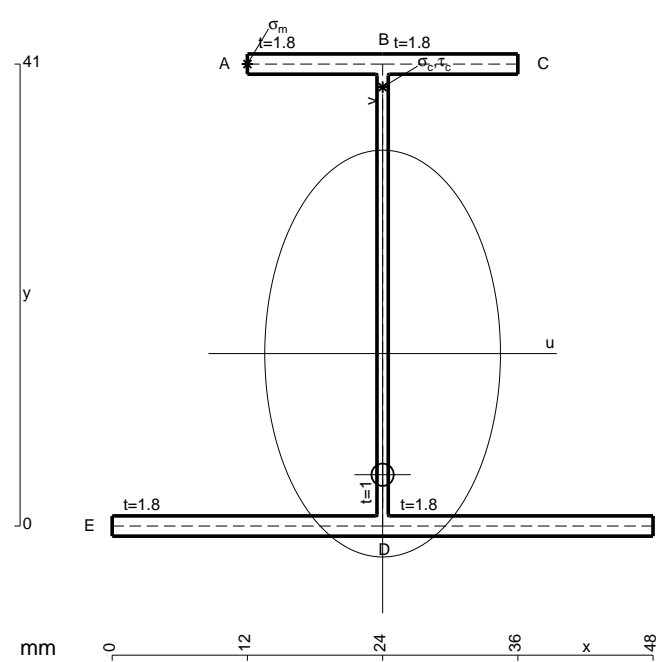

- A = 170.6 mm²
- J_u = 55611. mm⁴
- J_v = 18662. mm⁴
- J_w = 153.6 mm⁴
- y_o = -10.75 mm
- y_g = 15.31 mm
- N = -1060. N
- T_y = -1060. N
- M_x = -487600. Nmm
- x_m = 12. mm
- y_m = 41. mm
- u_m = -12. mm
- v_m = 25.69 mm
- σ_m = N/A - Mv/J_u = 219. N/mm²
- x_c = 24. mm
- y_c = 41. mm
- v_c = 25.69 mm
- σ_c = N/A - Mv/J_u = 219. N/mm²
- τ_c = TS_v/tJ_u = 21.16 N/mm²
- τ_g = TS_v/tJ_u = 21.16 N/mm²
- t_c = 530. mm
- σ_o = √σ² + 3τ² = 222.1 N/mm²

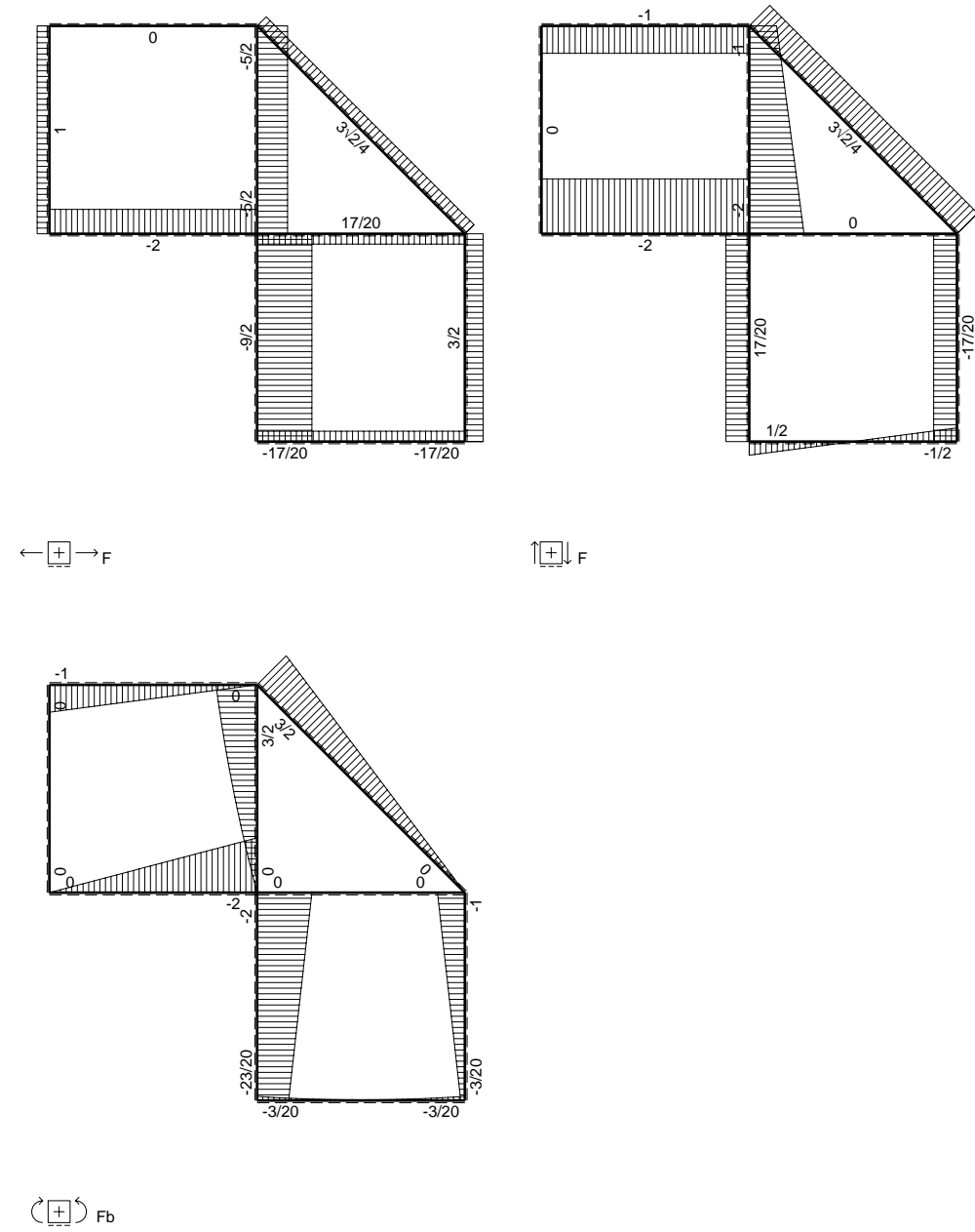
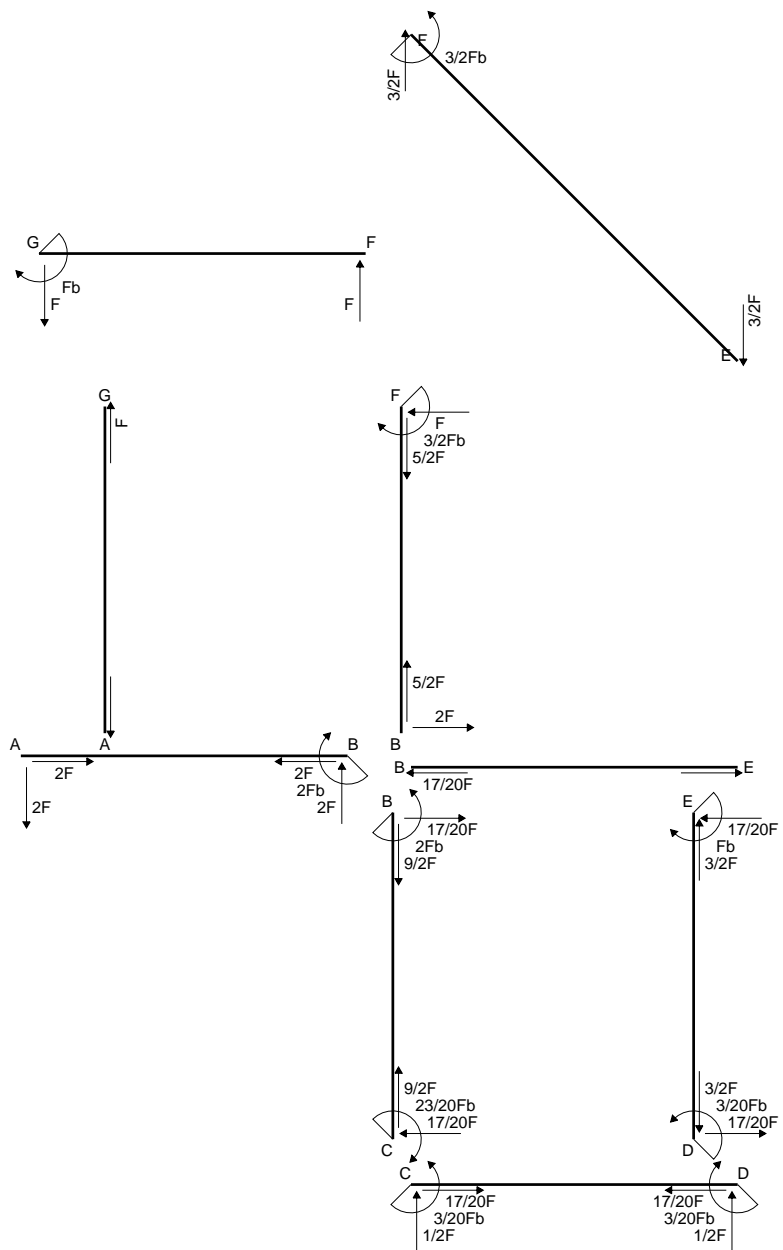

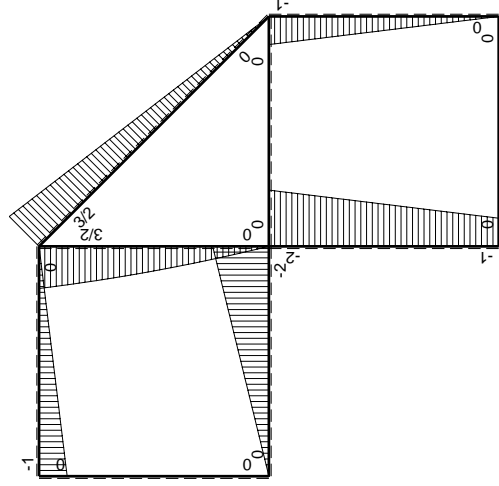
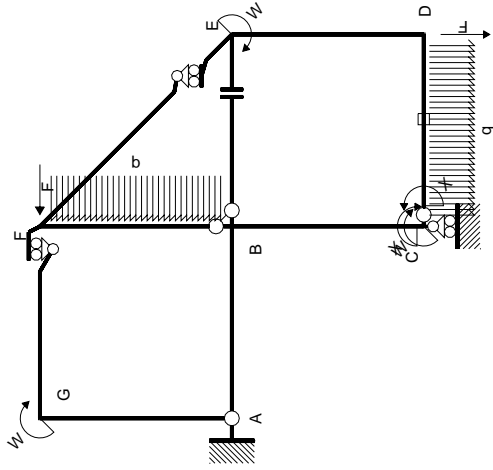

Schema di calcolo iperstatico

M_0 flessione da carichi assegnati

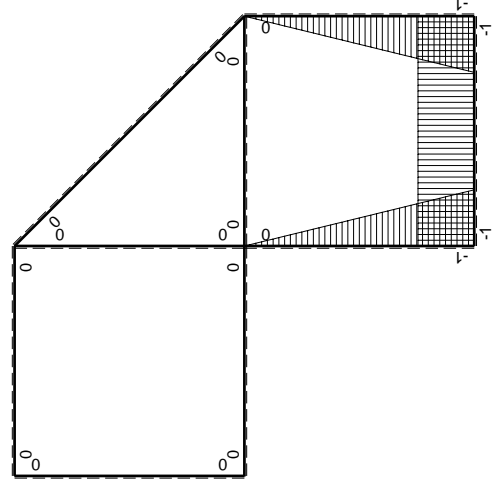

M_x flessione da iperstatica $X=1$

Quadro contribuiti PLV per iperstatica $X=W_{cd}$

\rightarrow	$M_x(x)$	$M_0(x)$	$M_x M_0$	$M_x M_x$	$\int M_x M_0 / E J dx$	$\int X M_x M_x / E J dx$
AB b	0	-2Fx	0	0	0	0
BA b	0	2Fb-2Fx	0	0	0	0
BC b	-x/b	-2Fb+Fx	2Fx-Fx ² /b	x ² /b ²	2/3Fb ² /EJ	1/3Xb/EJ
CB b	1-x/b	Fb+Fx	Fb-Fx ² /b	1-2x/b+x ² /b ²	-1/12Fb ² /EJ	Xb/EJ
CD b	-1	1/2Fx-1/2qx ²	-1/2Fx+1/2Fx ² /b	1	-1/12Fb ² /EJ	Xb/EJ
DC b	1	-1/2Fx+1/2qx ²	-1/2Fx+1/2Fx ² /b	1	1/6Fb ² /EJ	1/3Xb/EJ
DE b	-1+x/b	-Fx	Fx-Fx ² /b	1-2x/b+x ² /b ²	1/6Fb ² /EJ	1/3Xb/EJ
ED b	x/b	Fb-Fx	Fx-Fx ² /b	x ² /b ²	0	0
EF $\sqrt{2}b$	0	3\sqrt{2}/4Fx	0	0	0	0
FG b	0	-Fx	0	0	0	0
GF b	0	Fb-Fx	0	0	0	0
GA b	0	0	0	0	0	0
AG b	0	0	0	0	0	0
FB b	0	3/2Fb-Fx-1/2qx ²	0	0	0	0
BF b	0	-2Fx+1/2qx ²	0	0	0	0
BE b	0	0	0	0	0	0
EB b	0	0	0	0	0	0
CD	elongazione asta $N_{1,cd} \epsilon_{cd} L_{cd}$				-Fb ² /EJ	
	totali				-1/4Fb ² /EJ	5/3Xb/EJ
	iperstatica $X=W_{cd}$				3/20Fb	

Sviluppi di calcolo iperstatica

$$L_{BC}^{xx} = \int_0^b (x^2/b^2) 1/EJ dx = [1/3 x^3/b^2]_0^b 1/EJ$$

$$= (1/3 b) 1/EJ = 1/3 b/EJ$$

$$L_{CB}^{xx} = \int_0^b (1 - 2x/b + x^2/b^2) 1/EJ dx = [x - x^2/b + 1/3 x^3/b^2]_0^b 1/EJ$$

$$= (b - b + 1/3 b) 1/EJ = 1/3 b/EJ$$

$$L_{CD}^{xx} = \int_0^b (1) 1/EJ dx = [x]_0^b 1/EJ$$

$$= (b) 1/EJ = b/EJ$$

$$L_{DC}^{xx} = \int_0^b (1) 1/EJ dx = [x]_0^b 1/EJ$$

$$= (b) 1/EJ = b/EJ$$

$$L_{DE}^{xx} = \int_0^b (1 - 2x/b + x^2/b^2) 1/EJ dx = [x - x^2/b + 1/3 x^3/b^2]_0^b 1/EJ$$

$$= (b - b + 1/3 b) 1/EJ = 1/3 b/EJ$$

$$L_{ED}^{xx} = \int_0^b (x^2/b^2) 1/EJ dx = [1/3 x^3/b^2]_0^b 1/EJ$$

$$= (1/3 b) 1/EJ = 1/3 b/EJ$$

$$L_{BC}^{x_0} = \int_0^b (2x/b - x^2/b^2) Fb 1/EJ dx = [x^2/b - 1/3 x^3/b^2]_0^b Fb 1/EJ$$

$$= (b - 1/3 b) Fb 1/EJ = 2/3 Fb^2/EJ$$

$$L_{CB}^{x_0} = \int_0^b (1 - x^2/b^2) Fb 1/EJ dx = [x - 1/3 x^3/b^2]_0^b Fb 1/EJ$$

$$= (b - 1/3 b) Fb 1/EJ = 2/3 Fb^2/EJ$$

$$L_{CD}^{x_0} = \int_0^b (-1/2 x/b + 1/2 x^2/b^2) Fb 1/EJ dx + 1 (-1) 1 Fb^2/EJ$$

$$= [-1/4 x^2/b + 1/6 x^3/b^2]_0^b Fb 1/EJ + 1 (-1) 1 Fb^2/EJ$$

$$= (-1/4 b + 1/6 b) Fb 1/EJ + 1 (-1) 1 Fb^2/EJ = -13/12 Fb^2/EJ$$

$$L_{DC}^{x_0} = \int_0^b (-1/2 x/b + 1/2 x^2/b^2) Fb 1/EJ dx + 1 (-1) 1 Fb^2/EJ$$

$$= [-1/4 x^2/b + 1/6 x^3/b^2]_0^b Fb 1/EJ + 1 (-1) 1 Fb^2/EJ$$

$$= (-1/4 b + 1/6 b) Fb 1/EJ + 1 (-1) 1 Fb^2/EJ = -13/12 Fb^2/EJ$$

$$L_{DE}^{x_0} = \int_0^b (x/b - x^2/b^2) Fb 1/EJ dx = [1/2 x^2/b - 1/3 x^3/b^2]_0^b Fb 1/EJ$$

$$= (1/2 b - 1/3 b) Fb 1/EJ = 1/6 Fb^2/EJ$$

$$L_{ED}^{x_0} = \int_0^b (x/b - x^2/b^2) Fb 1/EJ dx = [1/2 x^2/b - 1/3 x^3/b^2]_0^b Fb 1/EJ$$

$$= (1/2 b - 1/3 b) Fb 1/EJ = 1/6 Fb^2/EJ$$

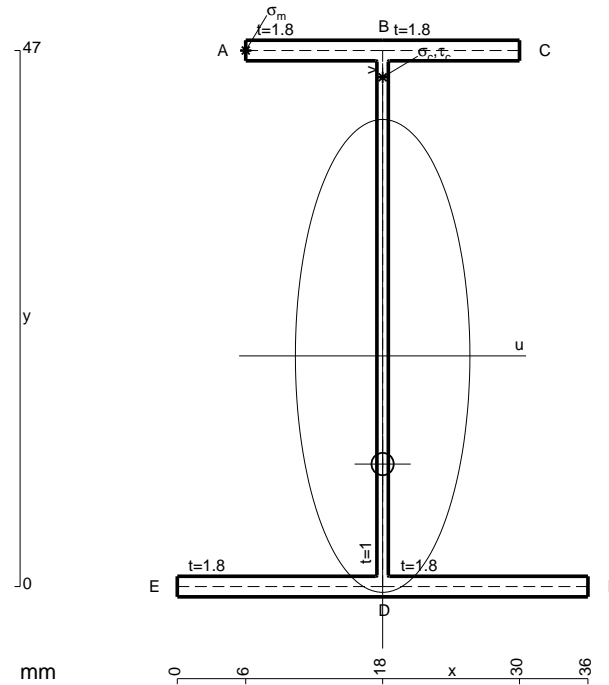

$$A = 155. \text{ mm}^2$$

$$J_u = 66633. \text{ mm}^4$$

$$J_v = 9072. \text{ mm}^4$$

$$J_t = 132.3 \text{ mm}^4$$

$$y_o = -9.482 \text{ mm}$$

$$y_g = 20.23 \text{ mm}$$

$$N = -1020. \text{ N}$$

$$T_y = -1020. \text{ N}$$

$$M_x = -581400. \text{ Nmm}$$

$$x_m = 6. \text{ mm}$$

$$y_m = 47. \text{ mm}$$

$$u_m = -12. \text{ mm}$$

$$v_m = 26.77 \text{ mm}$$

$$\sigma_m = N/A - Mv/J_u = 227. \text{ N/mm}^2$$

$$x_c = 18. \text{ mm}$$

$$y_c = 47. \text{ mm}$$

$$v_c = 26.77 \text{ mm}$$

$$\sigma_c = N/A - Mv/J_u = 227. \text{ N/mm}^2$$

$$\tau_c = TS/tJ_u = 17.71 \text{ N/mm}^2$$

$$\tau_g = TS/tJ_u = 17.71 \text{ N/mm}^2$$

$$t_c = 510. \text{ mm}$$

$$\sigma_o = \sqrt{\sigma^2 + 3\tau^2} = 229.1 \text{ N/mm}^2$$

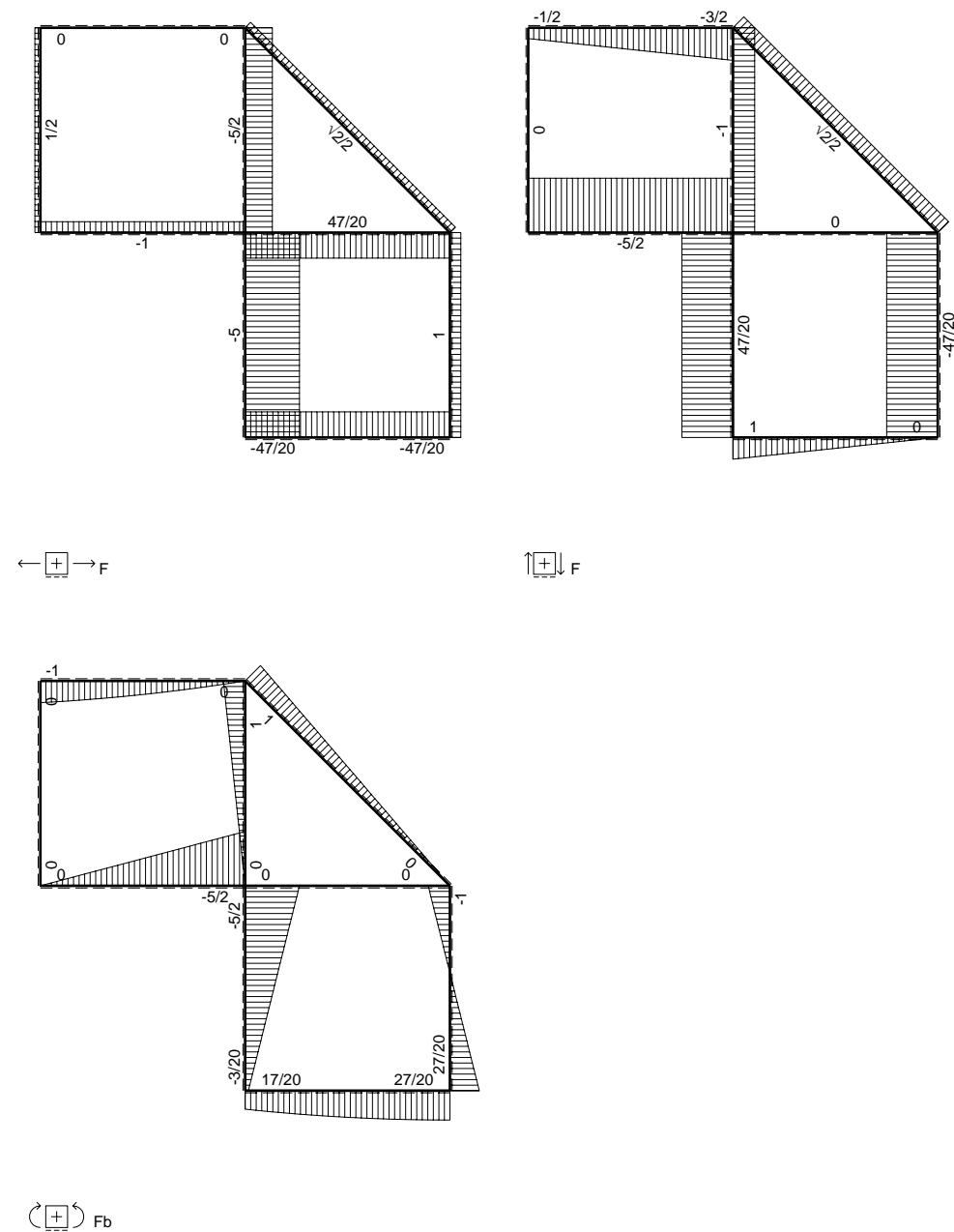
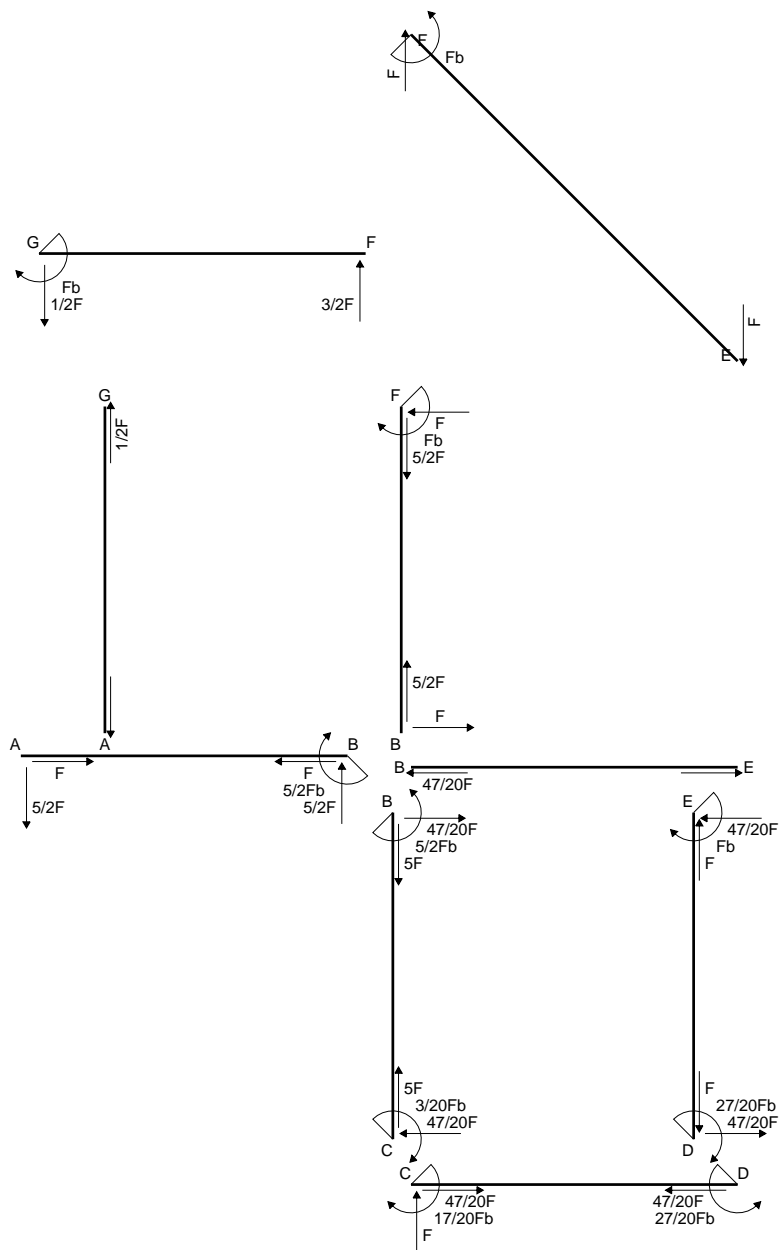

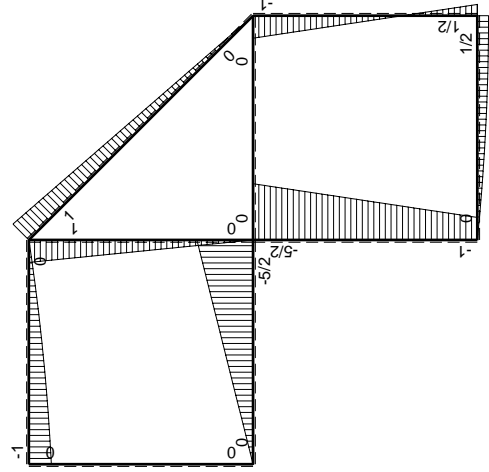
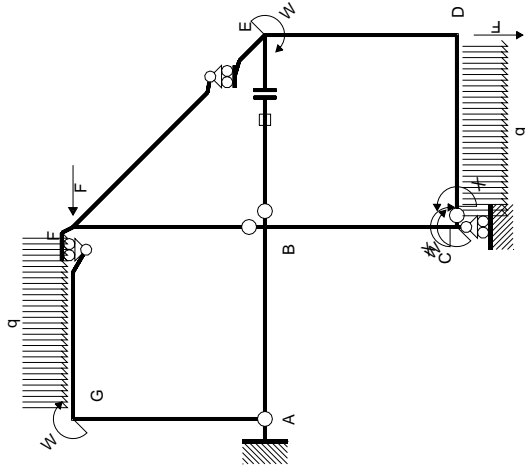

Schema di calcolo iperstatico

M_0 flessione da carichi assegnati

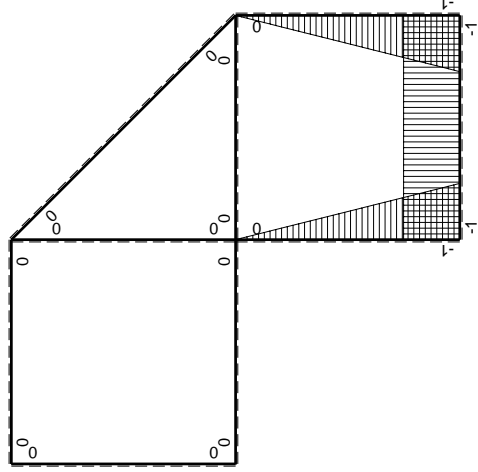

M_x flessione da iperstatica X=1

Quadro contribuiti PLV per iperstatica X=W_{CD}

→	$M_x(x)$	$M_0(x)$	$M_x M_0$	$M_x M_x$	$\int M_x M_0 / EJ dx$	$\int M_x M_x / EJ dx$
AB b	0	-5/2Fx	0	0	0	0
BA b	0	5/2Fb-5/2Fx	0	0	0	0
BC b	-x/b	-5/2Fb+3/2Fx	5/2Fx-3/2Fx ² /b	x ² /b ²	3/4Fb ² /EJ	1/3Xb/EJ
CB b	1-x/b	Fb+3/2Fx	Fb+1/2Fx-3/2Fx ² /b	1-2x/b+x ² /b ²	-1/3Fb ² /EJ	Xb/EJ
CD b	-1	Fx-1/2qx ²	-Fx+1/2Fx ² /b	1	-1/3Fb ² /EJ	Xb/EJ
DC b	1	-1/2Fb+1/2qx ²	-1/2Fb+1/2Fx ² /b	1	-1/3Fb ² /EJ	Xb/EJ
DE b	-1+x/b	1/2Fb-3/2Fx	-1/2Fb+2Fx-3/2Fx ² /b	1-2x/b+x ² /b ²	0	1/3Xb/EJ
ED b	x/b	Fb-3/2Fx	Fx-3/2Fx ² /b	x ² /b ²	0	1/3Xb/EJ
EF √2b	0	√2/2Fx	0	0	0	0
FG b	0	-3/2Fx+1/2qx ²	0	0	0	0
GF b	0	Fb-1/2Fx-1/2qx ²	0	0	0	0
GA b	0	0	0	0	0	0
AG b	0	0	0	0	0	0
FB b	0	Fb-Fx	0	0	0	0
BF b	0	-Fx	0	0	0	0
BE b	0	0	0	0	0	0
EB b	0	0	0	0	0	0
BE	elongazione asta $N_{1BE} \epsilon_{BE} = l_{BE}$				Fb ² /EJ	
	totali				17/12Fb ² /EJ	5/3Xb/EJ
	iperstatica X=W _{CD}				-17/20Fb	

Sviluppi di calcolo iperstatica

$$L_{BC}^{xx} = \int_0^b (x^2/b^2) 1/EJ dx = [1/3 x^3/b^2]_0^b 1/EJ$$

$$= (1/3 b) 1/EJ = 1/3 b/EJ$$

$$L_{CB}^{xx} = \int_0^b (1 - 2x/b + x^2/b^2) 1/EJ dx = [x - x^2/b + 1/3 x^3/b^2]_0^b 1/EJ$$

$$= (b - b + 1/3 b) 1/EJ = 1/3 b/EJ$$

$$L_{CD}^{xx} = \int_0^b (1) 1/EJ dx = [x]_0^b 1/EJ$$

$$= (b) 1/EJ = b/EJ$$

$$L_{DC}^{xx} = \int_0^b (1) 1/EJ dx = [x]_0^b 1/EJ$$

$$= (b) 1/EJ = b/EJ$$

$$L_{DE}^{xx} = \int_0^b (1 - 2x/b + x^2/b^2) 1/EJ dx = [x - x^2/b + 1/3 x^3/b^2]_0^b 1/EJ$$

$$= (b - b + 1/3 b) 1/EJ = 1/3 b/EJ$$

$$L_{ED}^{xx} = \int_0^b (x^2/b^2) 1/EJ dx = [1/3 x^3/b^2]_0^b 1/EJ$$

$$= (1/3 b) 1/EJ = 1/3 b/EJ$$

$$L_{BC}^{x_0} = \int_0^b (5/2 x/b - 3/2 x^2/b^2) Fb 1/EJ dx = [5/4 x^2/b - 1/2 x^3/b^2]_0^b Fb 1/EJ$$

$$= (5/4 b - 1/2 b) Fb 1/EJ = 3/4 Fb^2/EJ$$

$$L_{CB}^{x_0} = \int_0^b (1 + 1/2 x/b - 3/2 x^2/b^2) Fb 1/EJ dx = [x + 1/4 x^2/b - 1/2 x^3/b^2]_0^b Fb 1/EJ$$

$$= (b + 1/4 b - 1/2 b) Fb 1/EJ = 3/4 Fb^2/EJ$$

$$L_{CD}^{x_0} = \int_0^b (-x/b + 1/2 x^2/b^2) Fb 1/EJ dx = [-1/2 x^2/b + 1/6 x^3/b^2]_0^b Fb 1/EJ$$

$$= (-1/2 b + 1/6 b) Fb 1/EJ = -1/3 Fb^2/EJ$$

$$L_{DC}^{x_0} = \int_0^b (-1/2 + 1/2 x^2/b^2) Fb 1/EJ dx = [-1/2 x + 1/6 x^3/b^2]_0^b Fb 1/EJ$$

$$= (-1/2 b + 1/6 b) Fb 1/EJ = -1/3 Fb^2/EJ$$

$$L_{DE}^{x_0} = \int_0^b (-1/2 + 2x/b - 3/2 x^2/b^2) Fb 1/EJ dx = [-1/2 x + x^2/b - 1/2 x^3/b^2]_0^b Fb 1/EJ$$

$$= (-1/2 b + b - 1/2 b) Fb 1/EJ = 0$$

$$L_{ED}^{x_0} = \int_0^b (x/b - 3/2 x^2/b^2) Fb 1/EJ dx = [1/2 x^2/b - 1/2 x^3/b^2]_0^b Fb 1/EJ$$

$$= (1/2 b - 1/2 b) Fb 1/EJ = 0$$

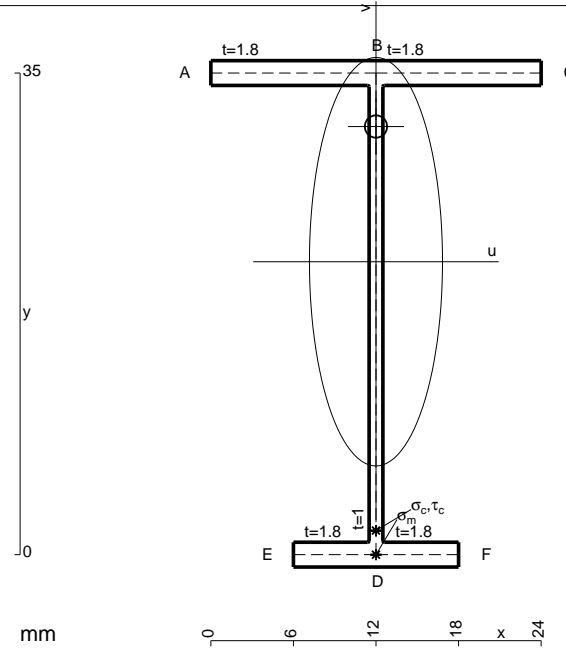

- A = 99.8 mm²
- J_u = 21986. mm⁴
- J_v = 2333. mm⁴
- J_I = 81.65 mm⁴
- y_o = 9.824 mm
- y_g = 21.29 mm
- N = -210. N
- T_y = -525. N
- M_x = -241500. Nmm
- x_m = 12. mm
- v_m = -21.29 mm
- σ_m = N/A - Mv/J_u = -235.9 N/mm²
- y_c = 3. mm
- u_c = -12. mm
- v_c = -18.29 mm
- σ_c = N/A - Mv/J_u = -235.9 N/mm²
- τ_c = TS_v/tJ_u = 10.98 N/mm²
- τ_g = TS_v/tJ_u = 10.98 N/mm²
- t_c = 210. mm
- σ_o = √σ² + 3τ² = 236.7 N/mm²

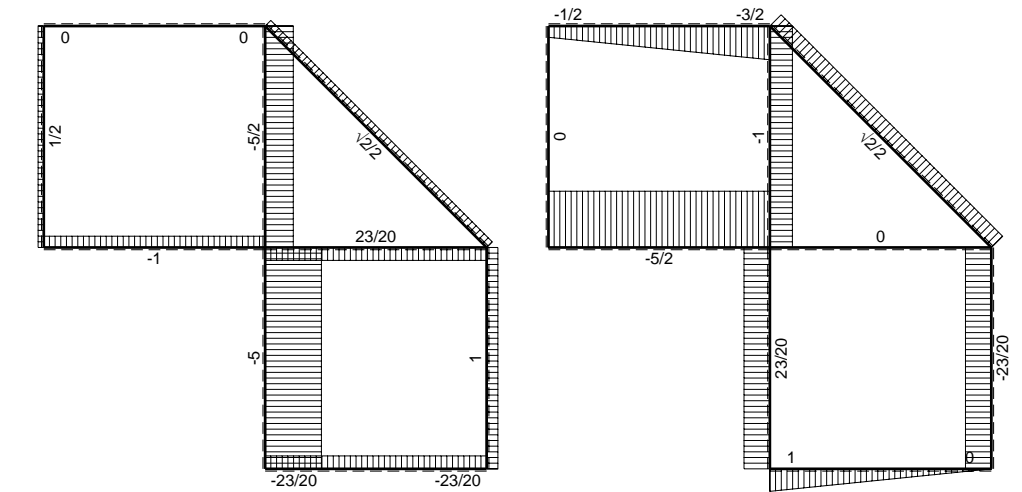
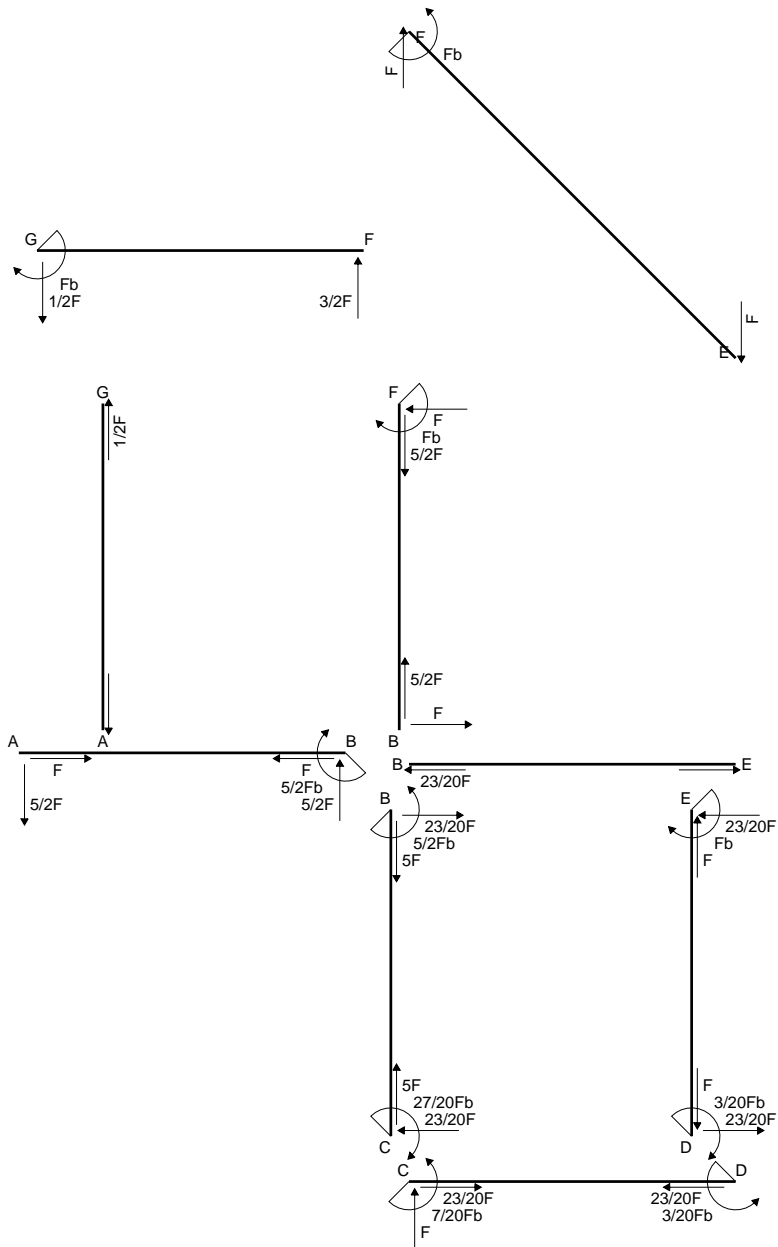

← ⊕ → F

↑ ⊕ ↓ F

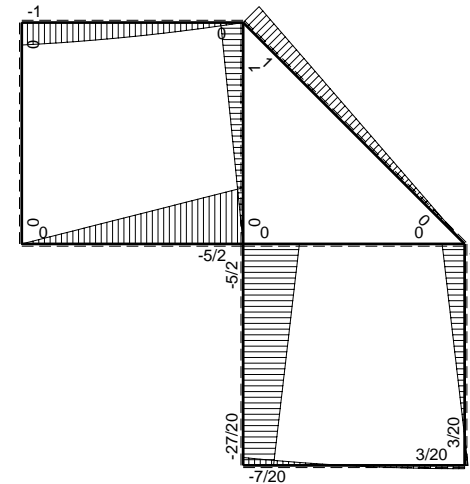

⊕ ⊖ F_b

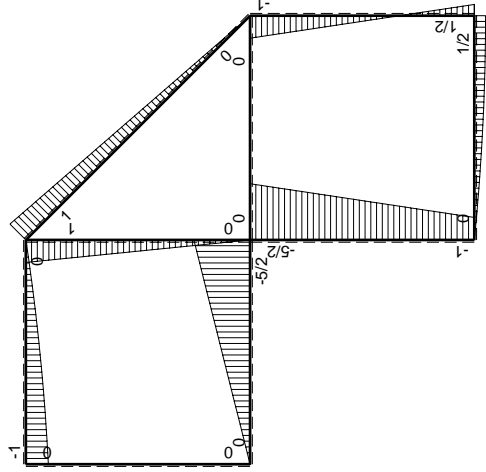
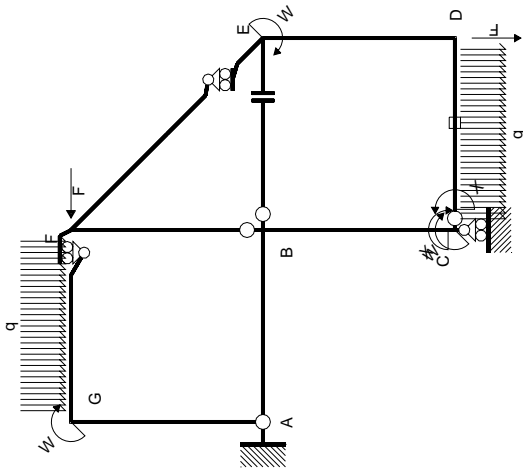

Schema di calcolo iperstatico

M_0 flessione da carichi assegnati

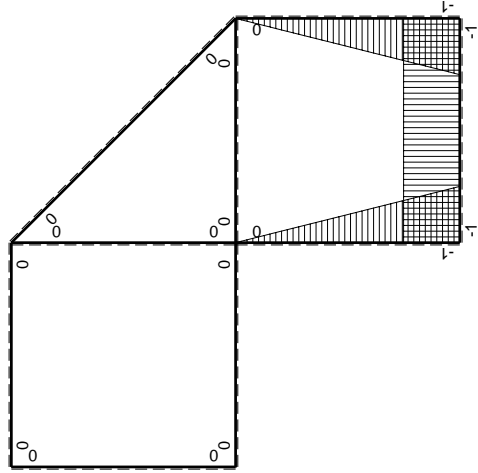

M_x flessione da iperstatica $X=1$

Quadro contributi PLV per iperstatica $X=W_{cd}$

\rightarrow	$M_x(x)$	$M_0(x)$	$M_x M_0$	$M_x M_x$	$\int M_x M_0 / EJ dx$	$\int M_x M_x / EJ dx$
AB b	0	$-5/2Fx$	0	0	0	0
BA b	0	$5/2Fb-5/2Fx$	0	0	0	0
BC b	$-x/b$	$-5/2Fb+3/2Fx$	$5/2Fx-3/2Fx^2/b$	x^2/b^2	$3/4Fb^2/EJ$	$1/3Xb/EJ$
CB b	$1-x/b$	$Fb+3/2Fx$	$Fb+1/2Fx-3/2Fx^2/b$	$1-2x/b+x^2/b^2$	$-1/3Fb^2/EJ$	Xb/EJ
CD b	-1	$Fx-1/2qx^2$	$-Fx+1/2Fx^2/b$	1	0	0
DC b	1	$-1/2Fb+1/2qx^2$	$-1/2Fb+1/2Fx^2/b$	1	0	0
DE b	$-1+x/b$	$1/2Fb-3/2Fx$	$-1/2Fb+2Fx-3/2Fx^2/b$	$1-2x/b+x^2/b^2$	0	$1/3Xb/EJ$
ED b	x/b	$Fb-3/2Fx$	$Fx-3/2Fx^2/b$	x^2/b^2	0	0
EF $\sqrt{2}b$	0	$\sqrt{2}/2Fx$	0	0	0	0
FG b	0	$-3/2Fx+1/2qx^2$	0	0	0	0
GF b	0	$Fb-1/2Fx-1/2qx^2$	0	0	0	0
GA b	0	0	0	0	0	0
AG b	0	0	0	0	0	0
FB b	0	$Fb-Fx$	0	0	0	0
BF b	0	$-Fx$	0	0	0	0
BE b	0	0	0	0	0	0
EB b	0	0	0	0	0	0
CD	elongazione asta $N_{1,cd} \epsilon_{cd} L_{cd}$				$-Fb^2/EJ$	
	totali				$-7/12Fb^2/EJ$	$5/3Xb/EJ$
	iperstatica $X=W_{cd}$				$7/20Fb$	

Sviluppi di calcolo iperstatica

$$L_{BC}^{xx} = \int_0^b (x^2/b^2) 1/EJ dx = [1/3 x^3/b^2]_0^b 1/EJ$$

$$= (1/3 b) 1/EJ = 1/3 b/EJ$$

$$L_{CB}^{xx} = \int_0^b (1 - 2x/b + x^2/b^2) 1/EJ dx = [x - x^2/b + 1/3 x^3/b^2]_0^b 1/EJ$$

$$= (b - b + 1/3 b) 1/EJ = 1/3 b/EJ$$

$$L_{CD}^{xx} = \int_0^b (1) 1/EJ dx = [x]_0^b 1/EJ$$

$$= (b) 1/EJ = b/EJ$$

$$L_{DC}^{xx} = \int_0^b (1) 1/EJ dx = [x]_0^b 1/EJ$$

$$= (b) 1/EJ = b/EJ$$

$$L_{DE}^{xx} = \int_0^b (1 - 2x/b + x^2/b^2) 1/EJ dx = [x - x^2/b + 1/3 x^3/b^2]_0^b 1/EJ$$

$$= (b - b + 1/3 b) 1/EJ = 1/3 b/EJ$$

$$L_{ED}^{xx} = \int_0^b (x^2/b^2) 1/EJ dx = [1/3 x^3/b^2]_0^b 1/EJ$$

$$= (1/3 b) 1/EJ = 1/3 b/EJ$$

$$L_{BC}^{xo} = \int_0^b (5/2 x/b - 3/2 x^2/b^2) Fb 1/EJ dx = [5/4 x^2/b - 1/2 x^3/b^2]_0^b Fb 1/EJ$$

$$= (5/4 b - 1/2 b) Fb 1/EJ = 3/4 Fb^2/EJ$$

$$L_{CB}^{xo} = \int_0^b (1 + 1/2 x/b - 3/2 x^2/b^2) Fb 1/EJ dx = [x + 1/4 x^2/b - 1/2 x^3/b^2]_0^b Fb 1/EJ$$

$$= (b + 1/4 b - 1/2 b) Fb 1/EJ = 3/4 Fb^2/EJ$$

$$L_{CD}^{xo} = \int_0^b (-x/b + 1/2 x^2/b^2) Fb 1/EJ dx + 1 (-1) 1 Fb^2/EJ$$

$$= [-1/2 x^2/b + 1/6 x^3/b^2]_0^b Fb 1/EJ + 1 (-1) 1 Fb^2/EJ$$

$$= (-1/2 b + 1/6 b) Fb 1/EJ + 1 (-1) 1 Fb^2/EJ = -4/3 Fb^2/EJ$$

$$L_{DC}^{xo} = \int_0^b (-1/2 + 1/2 x^2/b^2) Fb 1/EJ dx + 1 (-1) 1 Fb^2/EJ$$

$$= [-1/2 x + 1/6 x^3/b^2]_0^b Fb 1/EJ + 1 (-1) 1 Fb^2/EJ$$

$$= (-1/2 b + 1/6 b) Fb 1/EJ + 1 (-1) 1 Fb^2/EJ = -4/3 Fb^2/EJ$$

$$L_{DE}^{xo} = \int_0^b (-1/2 + 2x/b - 3/2 x^2/b^2) Fb 1/EJ dx = [-1/2 x + x^2/b - 1/2 x^3/b^2]_0^b Fb 1/EJ$$

$$= (-1/2 b + b - 1/2 b) Fb 1/EJ = 0$$

$$L_{ED}^{xo} = \int_0^b (x/b - 3/2 x^2/b^2) Fb 1/EJ dx = [1/2 x^2/b - 1/2 x^3/b^2]_0^b Fb 1/EJ$$

$$= (1/2 b - 1/2 b) Fb 1/EJ = 0$$

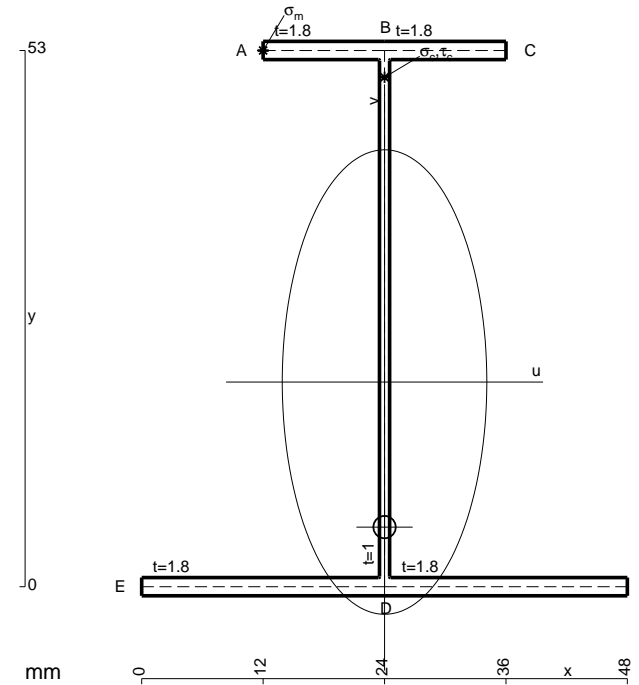

- A = 182.6 mm²
- J_u = 96241. mm⁴
- J_v = 18662. mm⁴
- J_t = 157.6 mm⁴
- y_o = -14.34 mm
- y_g = 20.23 mm
- N = -310. N
- T_y = -775. N
- M_x = -581250. Nmm
- x_m = 12. mm
- y_m = 53. mm
- u_m = -12. mm
- v_m = 32.77 mm
- σ_m = N/A - Mv/J_u = 196.2 N/mm²
- x_c = 24. mm
- y_c = 53. mm
- v_c = 32.77 mm
- σ_c = N/A - Mv/J_u = 196.2 N/mm²
- τ_c = TS'/tJ_u = 11.4 N/mm²
- τ_g = TS'/tJ_u = 11.4 N/mm²
- t_c = 310. mm
- σ_o = √σ² + 3τ² = 197.2 N/mm²

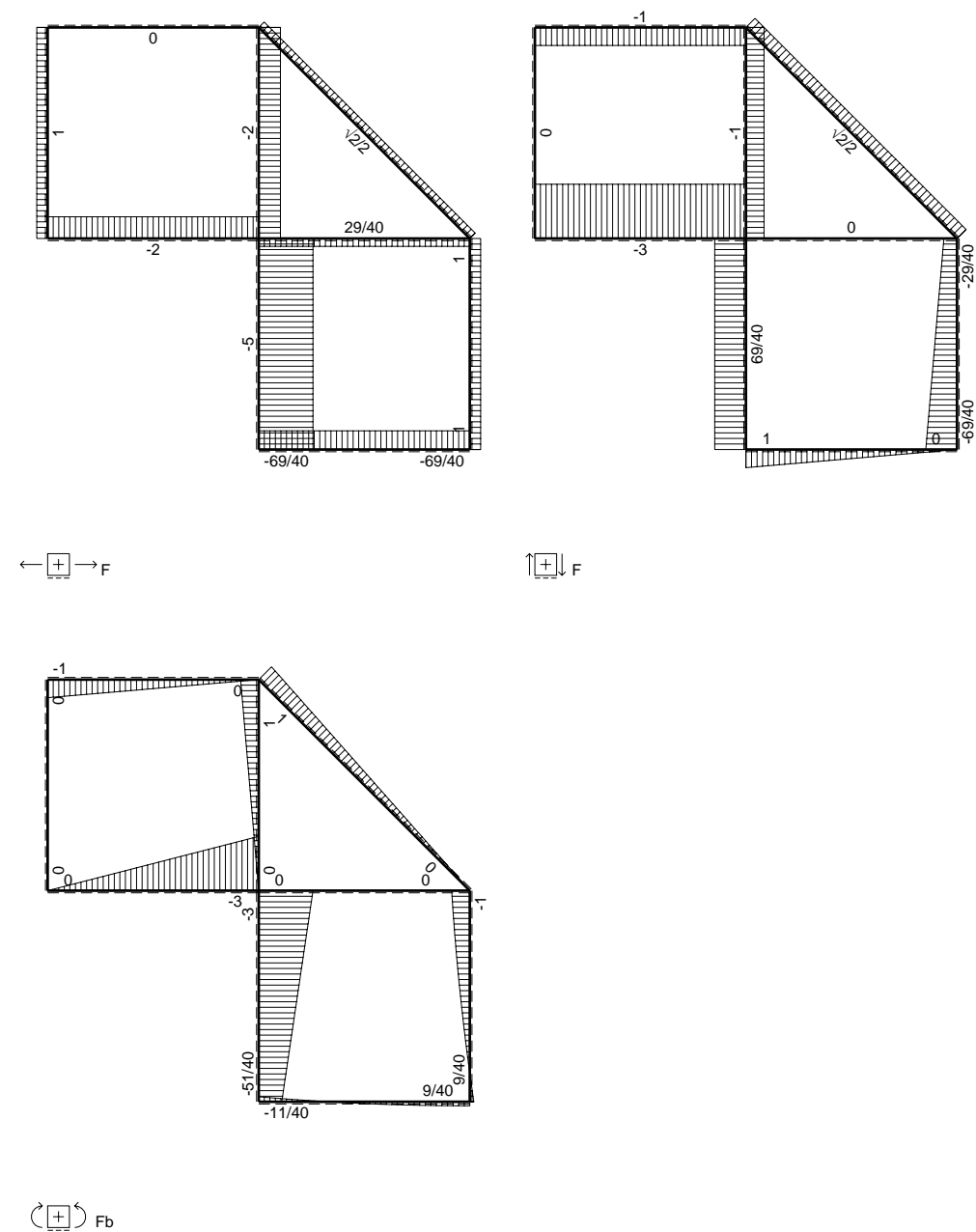
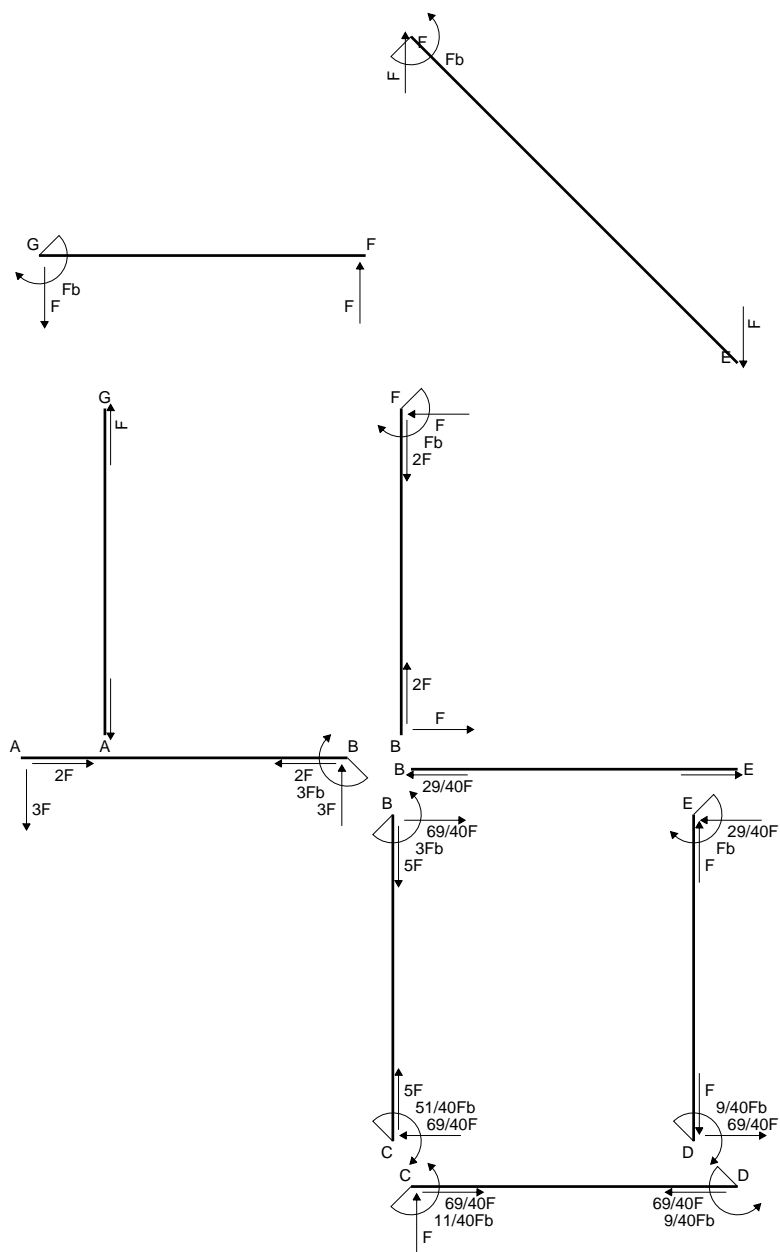

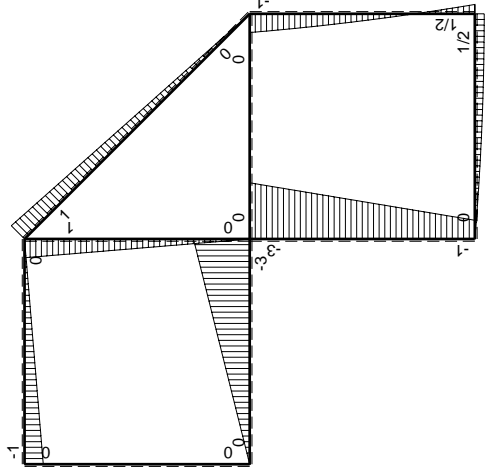
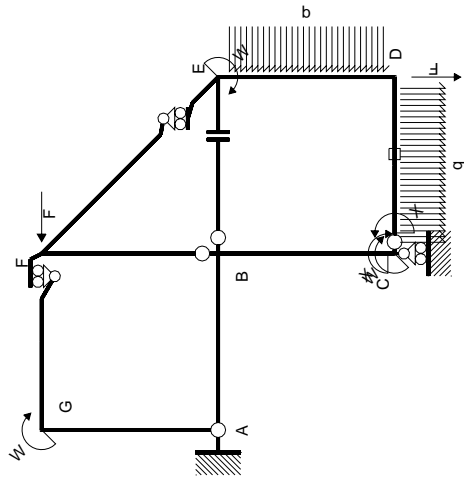

Schema di calcolo iperstatico

M_0 flessione da carichi assegnati

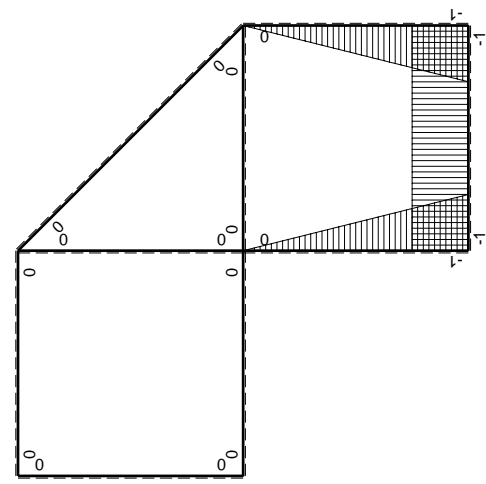

M_x flessione da iperstatica $X=1$

Quadro contributi PLV per iperstatica $X=W_{CD}$

→	$M_x(x)$	$M_o(x)$	$M_x M_o$	$M_x M_x$	$\int M_x M_o / EJ dx$	$\int X M_x M_x / EJ dx$
AB b	0	-3Fx	0	0	0	0
BA b	0	3Fb-3Fx	0	0	0	0
BC b	-x/b	-3Fb+2Fx	$3Fx-2Fx^2/b$	x^2/b^2	$5/6Fb^2/EJ$	$1/3Xb/EJ$
CB b	1-x/b	Fb+2Fx	$Fb+Fx-2Fx^2/b$	$1-2x/b+x^2/b^2$		
CD b	-1	$Fx-1/2qx^2$	$-Fx+1/2Fx^2/b$	1	$-1/3Fb^2/EJ$	Xb/EJ
DC b	1	$-1/2Fb+1/2qx^2$	$-1/2Fb+1/2Fx^2/b$	1		
DE b	-1+x/b	$1/2Fb-2Fx+1/2qx^2$	$-1/2Fb+5/2Fx-5/2Fx^2/b+1/2qx^3/b$	$1-2x/b+x^2/b^2$	$1/24Fb^2/EJ$	$1/3Xb/EJ$
ED b	x/b	$Fb-Fx-1/2qx^2$	$Fx-Fx^2/b-1/2qx^3/b$	x^2/b^2		
EF $\sqrt{2}b$	0	$\sqrt{2}/2Fx$	0	0	0	0
FG b	0	-Fx	0	0	0	0
GF b	0	Fb-Fx	0	0	0	0
GA b	0	0	0	0	0	0
AG b	0	0	0	0	0	0
FB b	0	Fb-Fx	0	0	0	0
BF b	0	-Fx	0	0	0	0
BE b	0	0	0	0	0	0
EB b	0	0	0	0	0	0
CD	elongazione asta $N_{1CD} \epsilon_{CD} L_{CD}$				$-Fb^2/EJ$	
	totali				$-11/24Fb^2/EJ$	$5/3Xb/EJ$
	iperstatica $X=W_{CD}$				$11/40Fb$	

Sviluppi di calcolo iperstatica

$$L_{BC}^{xx} = \int_0^b (x^2/b^2) 1/EJ dx = [1/3 x^3/b^2]_0^b 1/EJ$$

$$= (1/3 b) 1/EJ = 1/3 b/EJ$$

$$L_{CB}^{xx} = \int_0^b (1 - 2x/b + x^2/b^2) 1/EJ dx = [x - x^2/b + 1/3 x^3/b^2]_0^b 1/EJ$$

$$= (b - b + 1/3 b) 1/EJ = 1/3 b/EJ$$

$$L_{CD}^{xx} = \int_0^b (1) 1/EJ dx = [x]_0^b 1/EJ$$

$$= (b) 1/EJ = b/EJ$$

$$L_{DC}^{xx} = \int_0^b (1) 1/EJ dx = [x]_0^b 1/EJ$$

$$= (b) 1/EJ = b/EJ$$

$$L_{DE}^{xx} = \int_0^b (1 - 2x/b + x^2/b^2) 1/EJ dx = [x - x^2/b + 1/3 x^3/b^2]_0^b 1/EJ$$

$$= (b - b + 1/3 b) 1/EJ = 1/3 b/EJ$$

$$L_{ED}^{xx} = \int_0^b (x^2/b^2) 1/EJ dx = [1/3 x^3/b^2]_0^b 1/EJ$$

$$= (1/3 b) 1/EJ = 1/3 b/EJ$$

$$L_{BC}^{xo} = \int_0^b (3x/b - 2x^2/b^2) Fb 1/EJ dx = [3/2 x^2/b - 2/3 x^3/b^2]_0^b Fb 1/EJ$$

$$= (3/2 b - 2/3 b) Fb 1/EJ = 5/6 Fb^2/EJ$$

$$L_{CB}^{xo} = \int_0^b (1 + x/b - 2x^2/b^2) Fb 1/EJ dx = [x + 1/2 x^2/b - 2/3 x^3/b^2]_0^b Fb 1/EJ$$

$$= (b + 1/2 b - 2/3 b) Fb 1/EJ = 5/6 Fb^2/EJ$$

$$L_{CD}^{xo} = \int_0^b (-x/b + 1/2 x^2/b^2) Fb 1/EJ dx + 1 (-1) 1 Fb^2/EJ$$

$$= [-1/2 x^2/b + 1/6 x^3/b^2]_0^b Fb 1/EJ + 1 (-1) 1 Fb^2/EJ$$

$$= (-1/2 b + 1/6 b) Fb 1/EJ + 1 (-1) 1 Fb^2/EJ = -4/3 Fb^2/EJ$$

$$L_{DC}^{xo} = \int_0^b (-1/2 + 1/2 x^2/b^2) Fb 1/EJ dx + 1 (-1) 1 Fb^2/EJ$$

$$= [-1/2 x + 1/6 x^3/b^2]_0^b Fb 1/EJ + 1 (-1) 1 Fb^2/EJ$$

$$= (-1/2 b + 1/6 b) Fb 1/EJ + 1 (-1) 1 Fb^2/EJ = -4/3 Fb^2/EJ$$

$$L_{DE}^{xo} = \int_0^b (-1/2 + 5/2 x/b - 5/2 x^2/b^2 + 1/2 x^3/b^3) Fb 1/EJ dx$$

$$= [-1/2 x + 5/4 x^2/b - 5/6 x^3/b^2 + 1/8 x^4/b^3]_0^b Fb 1/EJ$$

$$= (-1/2 b + 5/4 b - 5/6 b + 1/8 b) Fb 1/EJ = 1/24 Fb^2/EJ$$

$$L_{ED}^{xo} = \int_0^b (x/b - x^2/b^2 - 1/2 x^3/b^3) Fb 1/EJ dx = [1/2 x^2/b - 1/3 x^3/b^2 - 1/8 x^4/b^3]_0^b Fb 1/EJ$$

$$= (1/2 b - 1/3 b - 1/8 b) Fb 1/EJ = 1/24 Fb^2/EJ$$

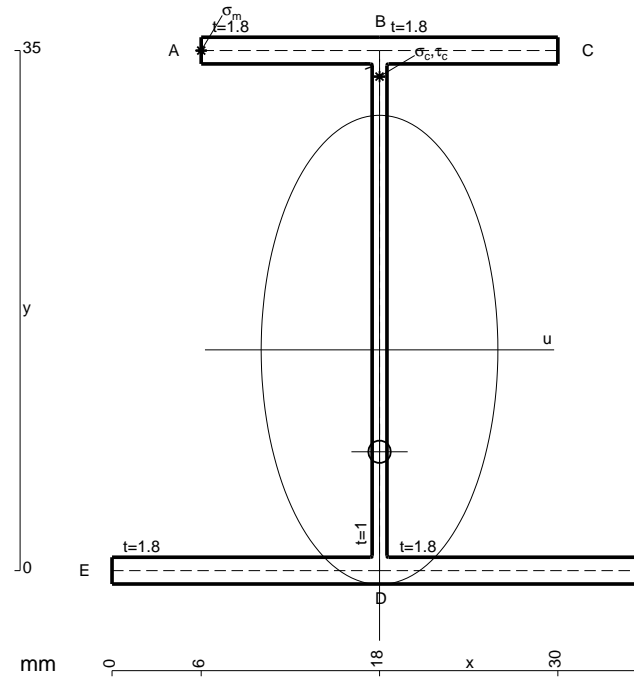

- A = 143. mm²
- J_u = 35649. mm⁴
- J_v = 9072. mm⁴
- J_t = 128.3 mm⁴
- y_o = -6.857 mm
- y_g = 14.86 mm
- N = -480. N
- T_y = -720. N
- M_x = -374400. Nmm
- x_m = 6. mm
- y_m = 35. mm
- u_m = -12. mm
- v_m = 20.14 mm
- σ_m = N/A-Mv/J_u = 208.2 N/mm²
- x_c = 18. mm
- y_c = 35. mm
- v_c = 20.14 mm
- σ_c = N/A-Mv/J_u = 208.2 N/mm²
- τ_c = TS'/tJ_u = 17.58 N/mm²
- τ_g = TS'/tJ_u = 17.58 N/mm²
- t_c = 240. mm
- σ_o = √(σ²+3τ²) = 210.4 N/mm²

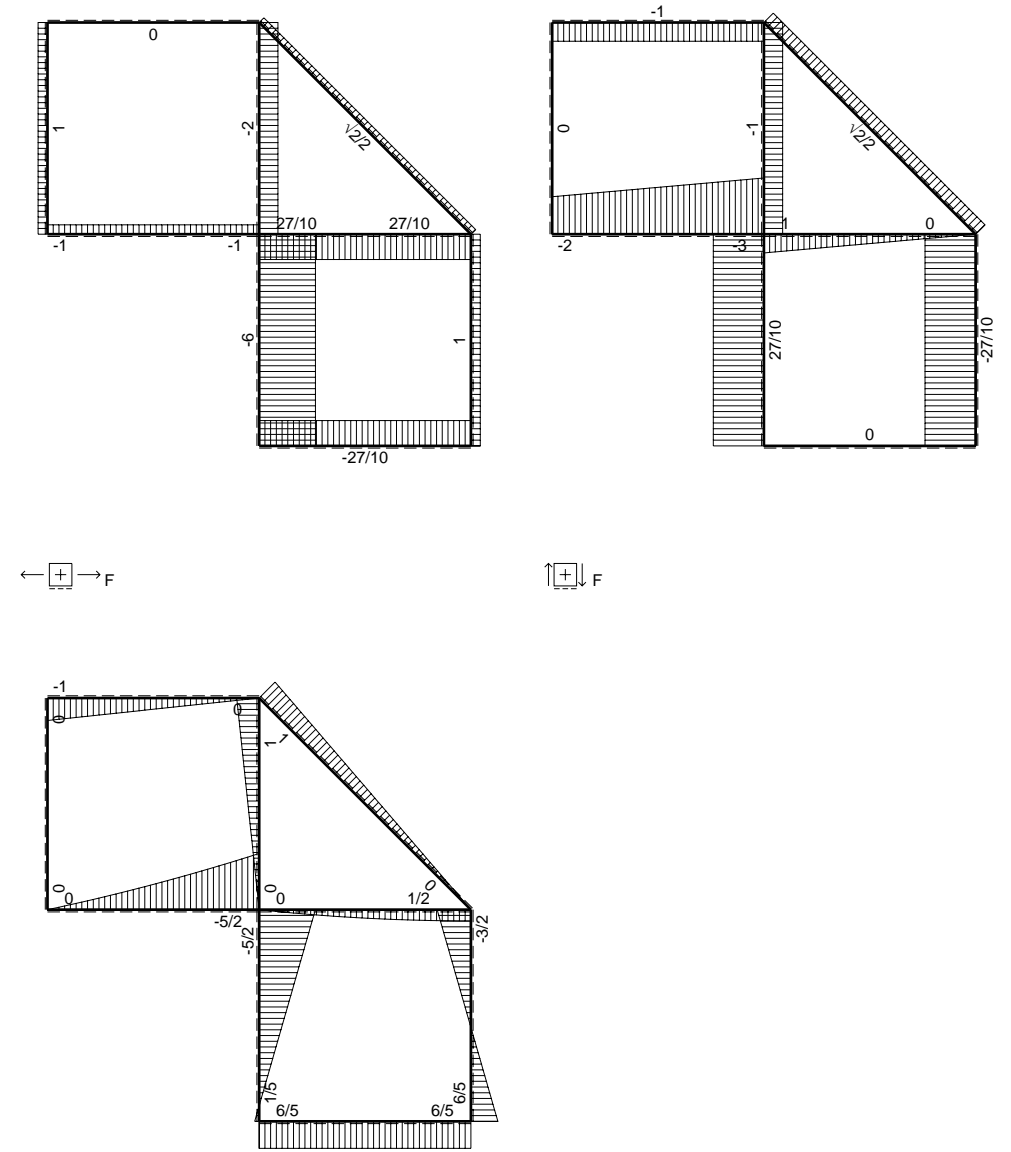
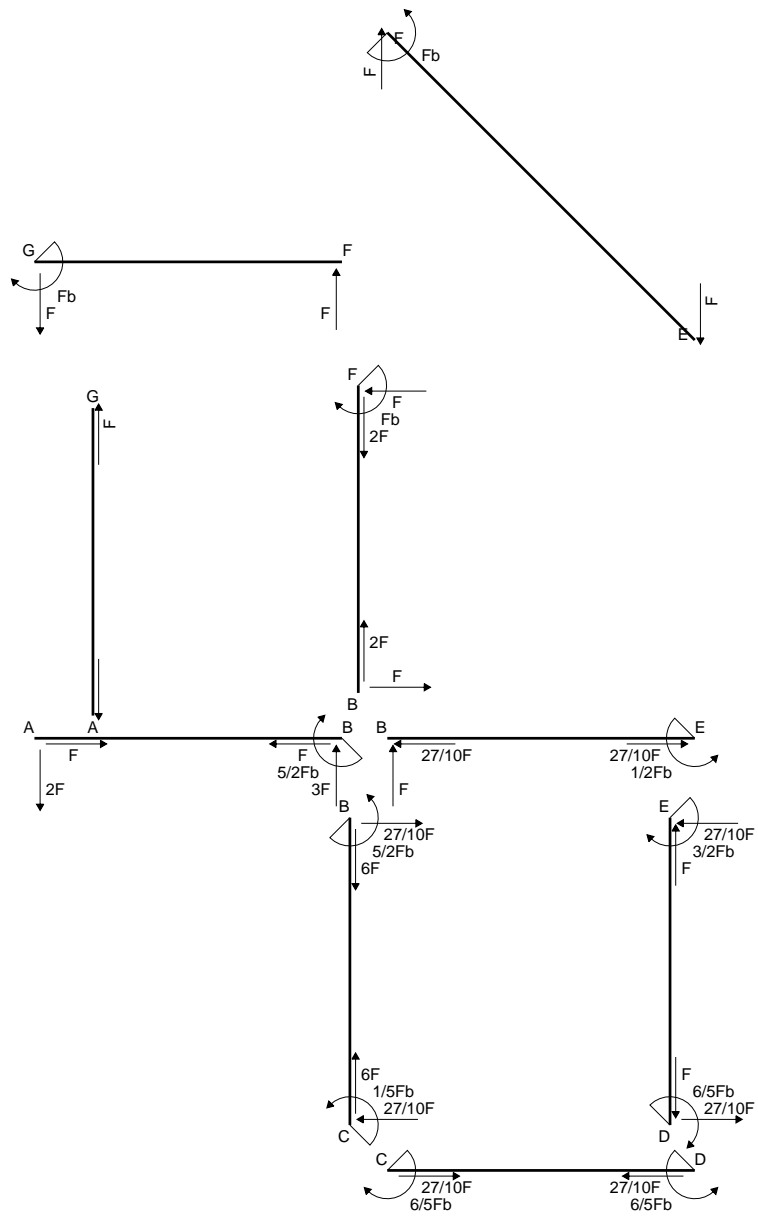

\oplus F_b

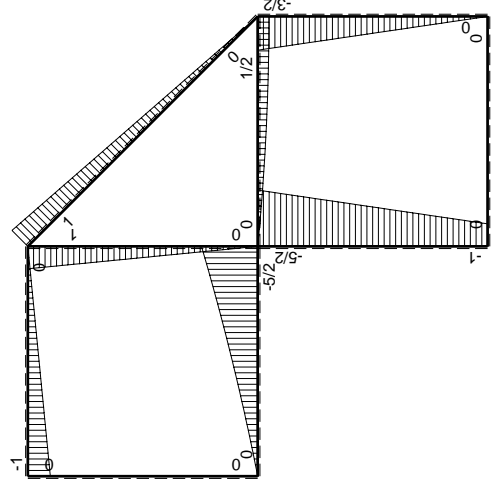
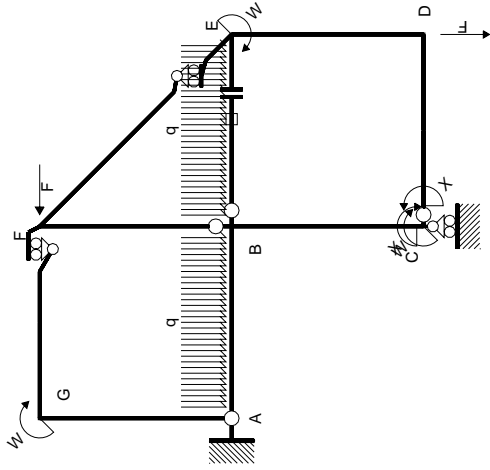

Schema di calcolo iperstatico

M_0 flessione da carichi assegnati

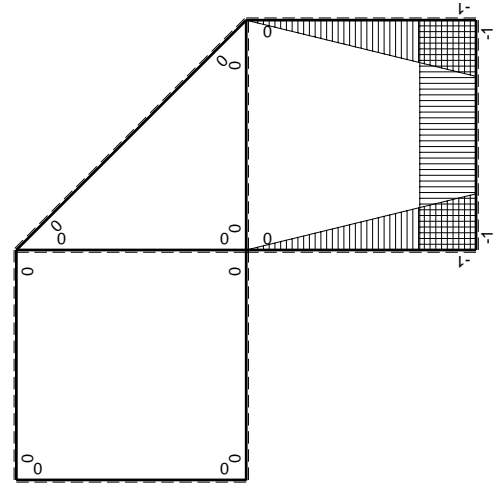

M_x flessione da iperstatica $X=1$

Quadro contribuiti PLV per iperstatica $X=W_{cd}$

\rightarrow	$M_x(x)$	$M_0(x)$	$M_x M_0$	$M_x M_x$	$\int M_x M_0 / EJ dx$	$\int M_x M_x / EJ dx$
AB b	0	$-2Fx - 1/2qx^2$	0	0	0	0
BA b	0	$5/2Fb - 3Fx + 1/2qx^2$	0	0	0	0
BC b	$-x/b$	$-5/2Fb + 3/2Fx$	$5/2Fx - 3/2Fx^2/b$	x^2/b^2	$3/4Fb^2/EJ$	$1/3Xb/EJ$
CB b	$1-x/b$	$Fb + 3/2Fx$	$Fb + 1/2Fx - 3/2Fx^2/b$	$1 - 2x/b + x^2/b^2$	0	Xb/EJ
CD b	-1	0	0	1	0	0
DC b	1	0	0	1	0	0
DE b	$-1 + x/b$	$-3/2Fx$	$3/2Fx - 3/2Fx^2/b$	$1 - 2x/b + x^2/b^2$	$1/4Fb^2/EJ$	$1/3Xb/EJ$
ED b	x/b	$3/2Fb - 3/2Fx$	$3/2Fx - 3/2Fx^2/b$	x^2/b^2	0	0
EF $\sqrt{2}b$	0	$\sqrt{2}/2Fx$	0	0	0	0
FG b	0	-Fx	0	0	0	0
GF b	0	$Fb - Fx$	0	0	0	0
GA b	0	0	0	0	0	0
AG b	0	0	0	0	0	0
FB b	0	$Fb - Fx$	0	0	0	0
BF b	0	-Fx	0	0	0	0
BE b	0	$Fx - 1/2qx^2$	0	0	0	0
EB b	0	$-1/2Fb + 1/2qx^2$	0	0	0	0
BE	elongazione asta $N_{1, BE}^E - L_{BE}^{E-BE}$				Fb^2/EJ	
	totali				$2Fb^2/EJ$	$5/3Xb/EJ$
	iperstatica $X=W_{cd}$				$-6/5Fb$	

Sviluppi di calcolo iperstatica

$$L_{BC}^{xx} = \int_0^b (x^2/b^2) 1/EJ dx = [1/3 x^3/b^2]_0^b 1/EJ$$

$$= (1/3 b) 1/EJ = 1/3 b/EJ$$

$$L_{CB}^{xx} = \int_0^b (1 - 2x/b + x^2/b^2) 1/EJ dx = [x - x^2/b + 1/3 x^3/b^2]_0^b 1/EJ$$

$$= (b - b + 1/3 b) 1/EJ = 1/3 b/EJ$$

$$L_{CD}^{xx} = \int_0^b (1) 1/EJ dx = [x]_0^b 1/EJ$$

$$= (b) 1/EJ = b/EJ$$

$$L_{DC}^{xx} = \int_0^b (1) 1/EJ dx = [x]_0^b 1/EJ$$

$$= (b) 1/EJ = b/EJ$$

$$L_{DE}^{xx} = \int_0^b (1 - 2x/b + x^2/b^2) 1/EJ dx = [x - x^2/b + 1/3 x^3/b^2]_0^b 1/EJ$$

$$= (b - b + 1/3 b) 1/EJ = 1/3 b/EJ$$

$$L_{ED}^{xx} = \int_0^b (x^2/b^2) 1/EJ dx = [1/3 x^3/b^2]_0^b 1/EJ$$

$$= (1/3 b) 1/EJ = 1/3 b/EJ$$

$$L_{BC}^{x_0} = \int_0^b (5/2 x/b - 3/2 x^2/b^2) Fb 1/EJ dx = [5/4 x^2/b - 1/2 x^3/b^2]_0^b Fb 1/EJ$$

$$= (5/4 b - 1/2 b) Fb 1/EJ = 3/4 Fb^2/EJ$$

$$L_{CB}^{x_0} = \int_0^b (1 + 1/2 x/b - 3/2 x^2/b^2) Fb 1/EJ dx = [x + 1/4 x^2/b - 1/2 x^3/b^2]_0^b Fb 1/EJ$$

$$= (b + 1/4 b - 1/2 b) Fb 1/EJ = 3/4 Fb^2/EJ$$

$$L_{DE}^{x_0} = \int_0^b (3/2 x/b - 3/2 x^2/b^2) Fb 1/EJ dx = [3/4 x^2/b - 1/2 x^3/b^2]_0^b Fb 1/EJ$$

$$= (3/4 b - 1/2 b) Fb 1/EJ = 1/4 Fb^2/EJ$$

$$L_{ED}^{x_0} = \int_0^b (3/2 x/b - 3/2 x^2/b^2) Fb 1/EJ dx = [3/4 x^2/b - 1/2 x^3/b^2]_0^b Fb 1/EJ$$

$$= (3/4 b - 1/2 b) Fb 1/EJ = 1/4 Fb^2/EJ$$

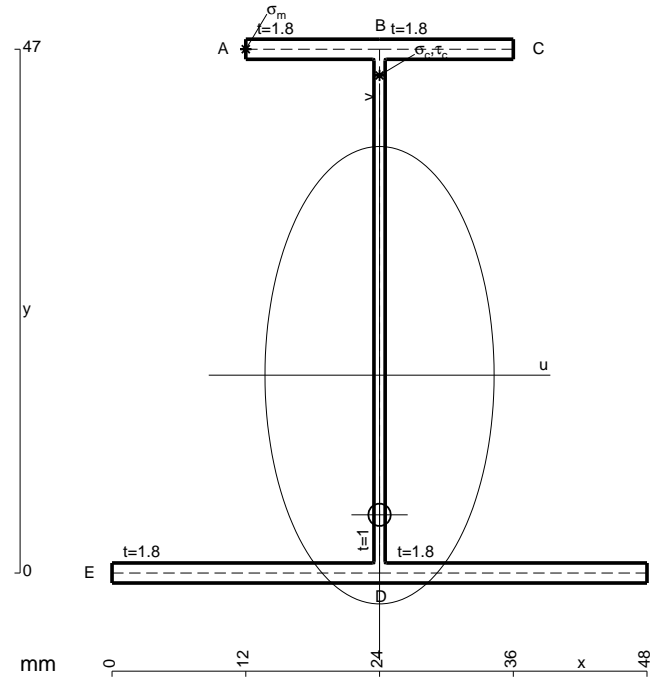

- A = 176.6 mm²
- J_u = 74388. mm⁴
- J_v = 18662. mm⁴
- J_t = 155.6 mm⁴
- y_o = -12.53 mm
- y_g = 17.75 mm
- N = -300. N
- T_y = -900. N
- M_x = -555000. Nmm
- x_m = 12. mm
- y_m = 47. mm
- u_m = -12. mm
- v_m = 29.25 mm
- σ_m = N/A-Mv/J_u = 216.5 N/mm²
- x_c = 24. mm
- y_c = 47. mm
- v_c = 29.25 mm
- σ_c = N/A-Mv/J_u = 216.5 N/mm²
- τ_c = TS²/tJ_u = 15.29 N/mm²
- τ_g = TS²/tJ_u = 15.29 N/mm²
- t_c = 300. mm
- σ_o = √σ²+3τ² = 218.1 N/mm²

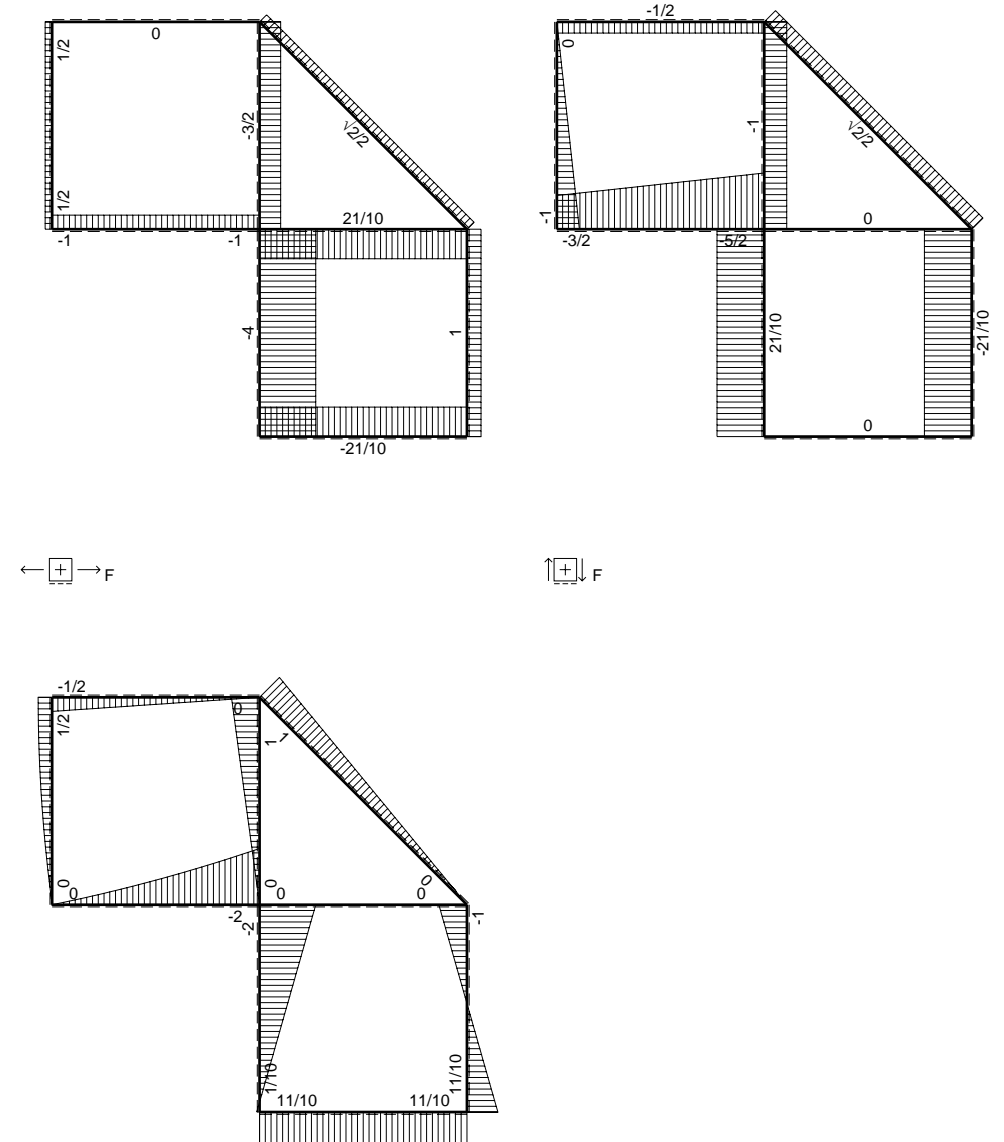
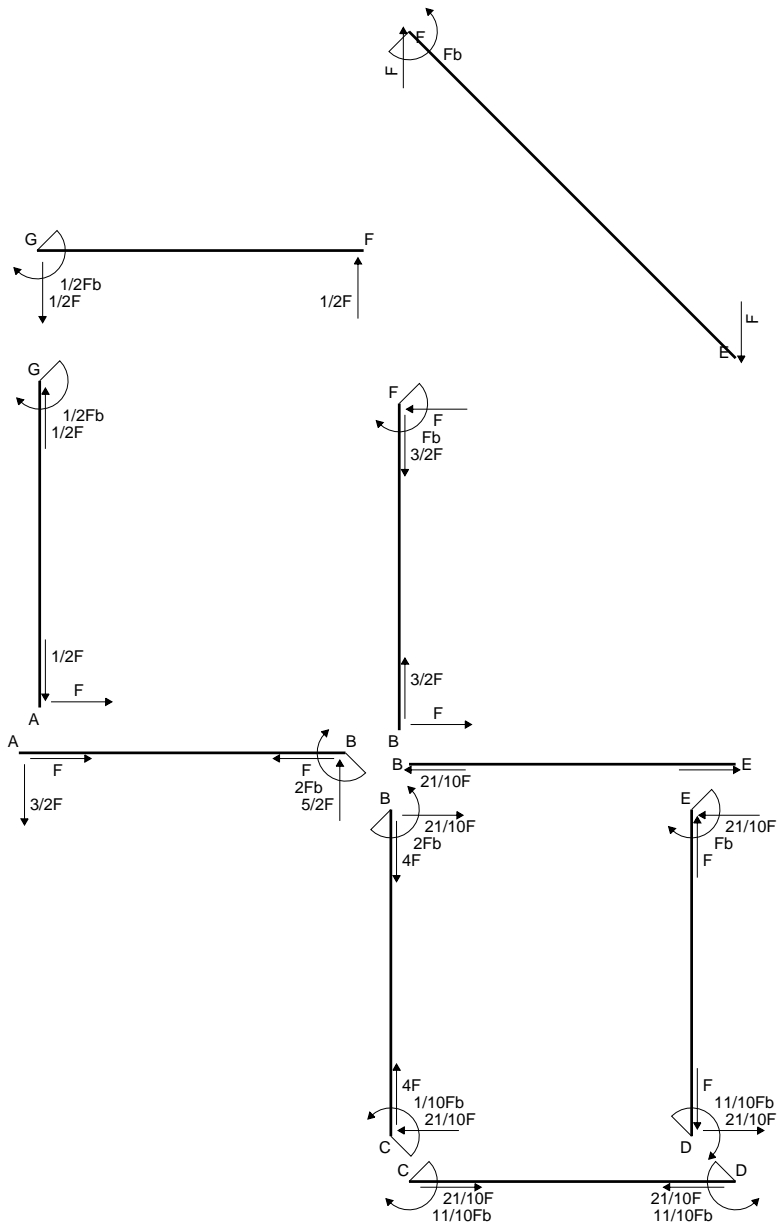

$\curvearrowright (+) F_b$

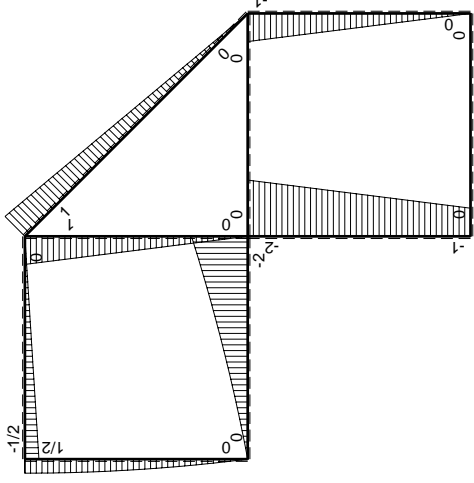
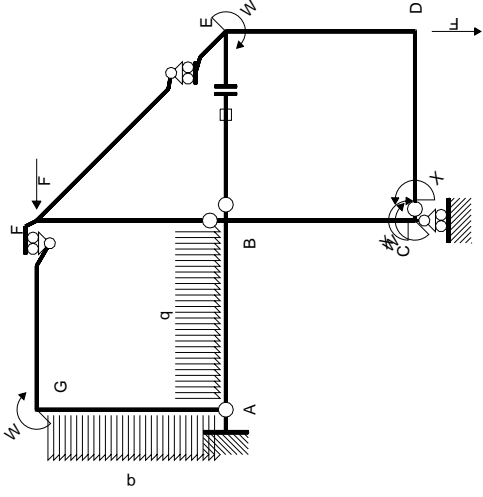

Schema di calcolo iperstatico

M_0 flessione da carichi assegnati

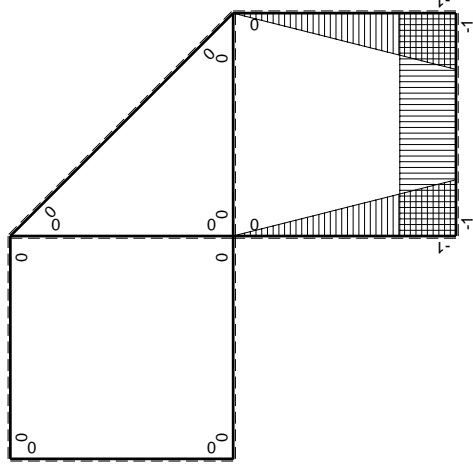

M_x flessione da iperstatica X=1

Quadro contributi PLV per iperstatica X=W_{CD}

→	M _x (x)	M ₀ (x)	M _x M ₀	M _x M _x	$\int M_x M_0 / E J dx$	$\int X M_x M_x / E J dx$
AB b	0	-3/2Fx-1/2qx ²	0	0	0	0
BA b	0	2Fb-5/2Fx+1/2qx ²	0	0	0	0
BC b	-x/b	-2Fb+Fx	2Fx-Fx ² /b	x ² /b ²	2/3Fb ² /EJ	1/3Xb/EJ
CB b	1-x/b	Fb+Fx	Fb-Fx ² /b	1-2x/b+x ² /b ²		
CD b	-1	0	0	1	0	Xb/EJ
DC b	1	0	0	1	0	
DE b	-1+x/b	-Fx	Fx-Fx ² /b	1-2x/b+x ² /b ²	1/6Fb ² /EJ	1/3Xb/EJ
ED b	x/b	Fb-Fx	Fx-Fx ² /b	x ² /b ²		
EF √2b	0	√2/2Fx	0	0	0	0
FG b	0	-1/2Fx	0	0	0	0
GF b	0	1/2Fb-1/2Fx	0	0	0	0
GA b	0	1/2Fb-1/2qx ²	0	0	0	0
AG b	0	-Fx+1/2qx ²	0	0	0	0
FB b	0	Fb-Fx	0	0	0	0
BF b	0	-Fx	0	0	0	0
BE b	0	0	0	0	0	0
EB b	0	0	0	0	0	0
BE	elongazione asta N _{1, BE} ε _{BE} L _{BE}				Fb ² /EJ	
	totali				11/6Fb ² /EJ	5/3Xb/EJ
	iperstatica X=W _{CD}					-11/10Fb

Sviluppi di calcolo iperstatica

$$L_{BC}^{xx} = \int_0^b (x^2/b^2) 1/EJ dx = [1/3 x^3/b^2]_0^b 1/EJ$$

$$= (1/3 b) 1/EJ = 1/3 b/EJ$$

$$L_{CB}^{xx} = \int_0^b (1 - 2x/b + x^2/b^2) 1/EJ dx = [x - x^2/b + 1/3 x^3/b^2]_0^b 1/EJ$$

$$= (b - b + 1/3 b) 1/EJ = 1/3 b/EJ$$

$$L_{CD}^{xx} = \int_0^b (1) 1/EJ dx = [x]_0^b 1/EJ$$

$$= (b) 1/EJ = b/EJ$$

$$L_{DC}^{xx} = \int_0^b (1) 1/EJ dx = [x]_0^b 1/EJ$$

$$= (b) 1/EJ = b/EJ$$

$$L_{DE}^{xx} = \int_0^b (1 - 2x/b + x^2/b^2) 1/EJ dx = [x - x^2/b + 1/3 x^3/b^2]_0^b 1/EJ$$

$$= (b - b + 1/3 b) 1/EJ = 1/3 b/EJ$$

$$L_{ED}^{xx} = \int_0^b (x^2/b^2) 1/EJ dx = [1/3 x^3/b^2]_0^b 1/EJ$$

$$= (1/3 b) 1/EJ = 1/3 b/EJ$$

$$L_{BC}^{xo} = \int_0^b (2x/b - x^2/b^2) Fb 1/EJ dx = [x^2/b - 1/3 x^3/b^2]_0^b Fb 1/EJ$$

$$= (b - 1/3 b) Fb 1/EJ = 2/3 Fb^2/EJ$$

$$L_{CB}^{xo} = \int_0^b (1 - x^2/b^2) Fb 1/EJ dx = [x - 1/3 x^3/b^2]_0^b Fb 1/EJ$$

$$= (b - 1/3 b) Fb 1/EJ = 2/3 Fb^2/EJ$$

$$L_{DE}^{xo} = \int_0^b (x/b - x^2/b^2) Fb 1/EJ dx = [1/2 x^2/b - 1/3 x^3/b^2]_0^b Fb 1/EJ$$

$$= (1/2 b - 1/3 b) Fb 1/EJ = 1/6 Fb^2/EJ$$

$$L_{ED}^{xo} = \int_0^b (x/b - x^2/b^2) Fb 1/EJ dx = [1/2 x^2/b - 1/3 x^3/b^2]_0^b Fb 1/EJ$$

$$= (1/2 b - 1/3 b) Fb 1/EJ = 1/6 Fb^2/EJ$$

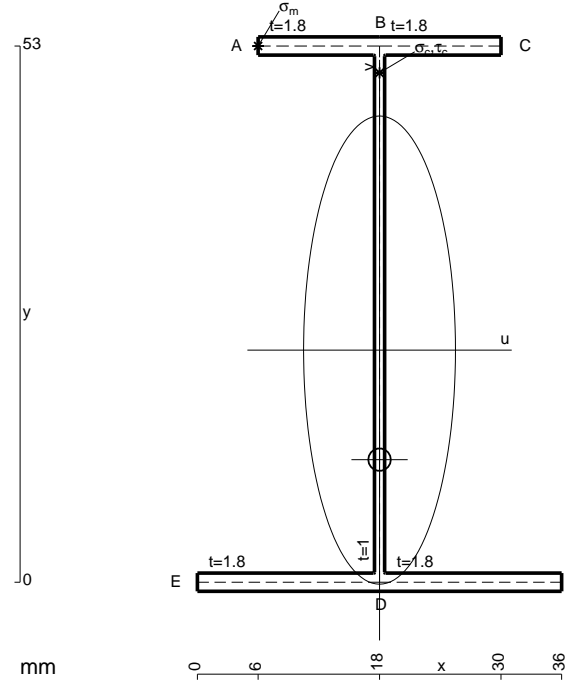

- A = 161. mm²
- J_u = 86214. mm⁴
- J_v = 9072. mm⁴
- J_t = 134.3 mm⁴
- y_o = -10.83 mm
- y_g = 22.94 mm
- N = -370. N
- T_y = -925. N
- M_x = -666000. Nmm
- x_m = 6. mm
- y_m = 53. mm
- u_m = -12. mm
- v_m = 30.06 mm
- σ_m = N/A - Mv/J_u = 229.9 N/mm²
- x_c = 18. mm
- y_c = 53. mm
- v_c = 30.06 mm
- σ_c = N/A - Mv/J_u = 229.9 N/mm²
- τ_c = TS'/tJ_u = 13.93 N/mm²
- τ_g = TS'/tJ_u = 13.93 N/mm²
- t_c = 370. mm
- σ_o = √σ² + 3τ² = 231.1 N/mm²

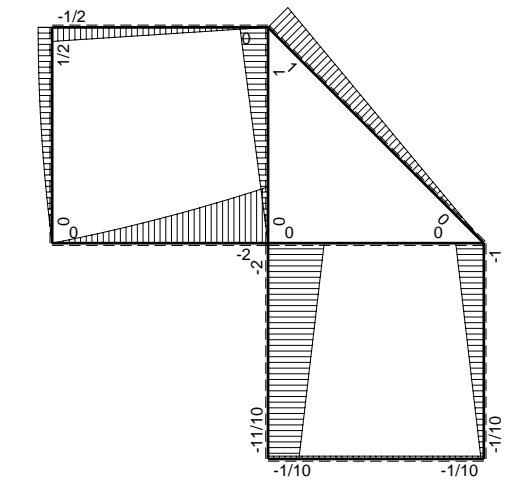
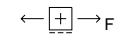
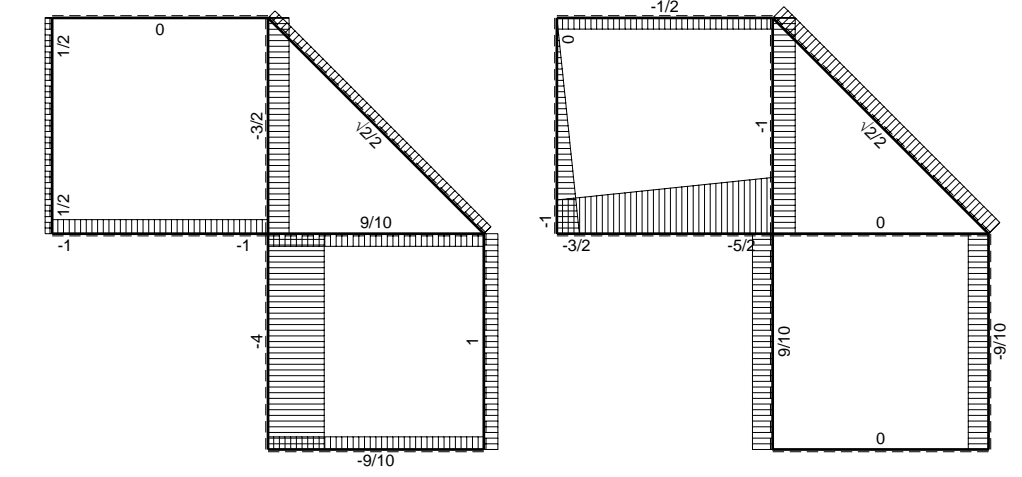
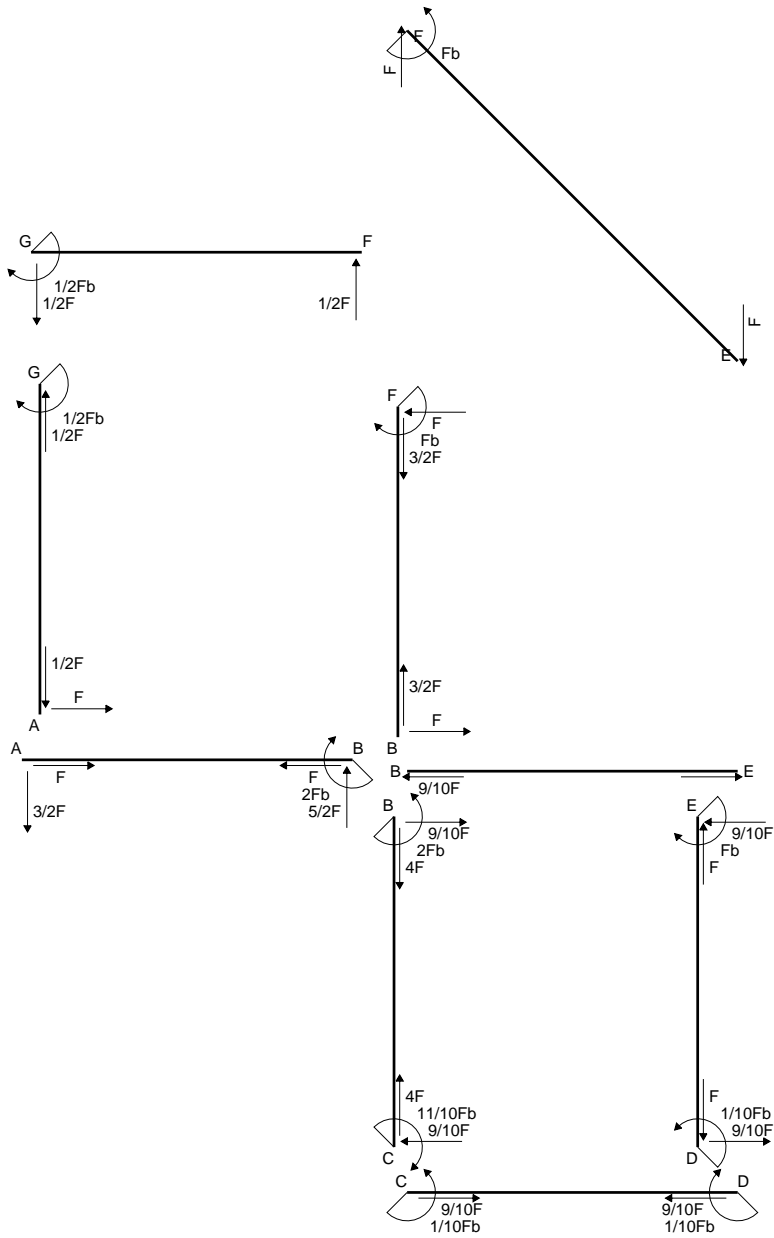

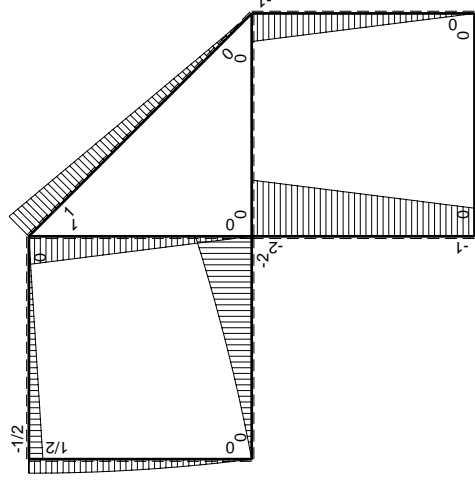
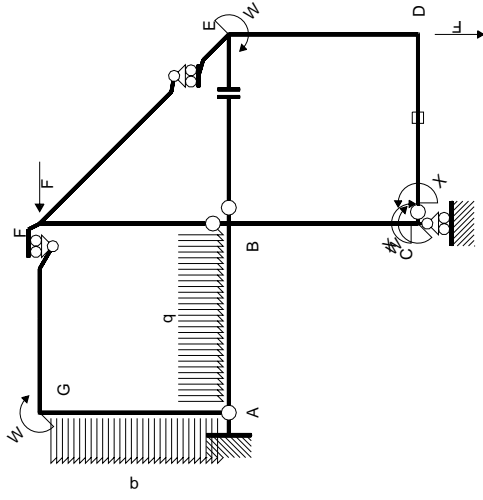

Schema di calcolo iperstatico

M_0 flessione da carichi assegnati

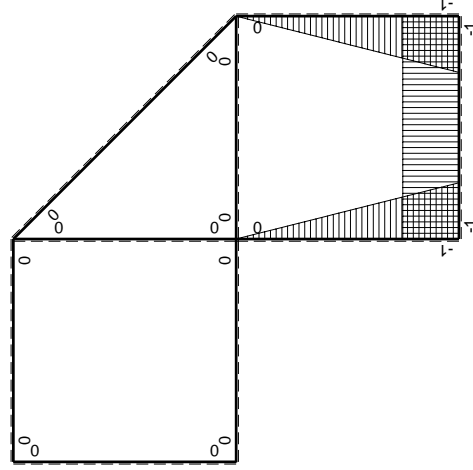

M_x flessione da iperstatica $X=1$

Quadro contribuiti PLV per iperstatica $X=W_{CD}$

\rightarrow	$M_x(x)$	$M_0(x)$	$M_x M_0$	$M_x M_x$	$\int M_x M_0 / E J dx$	$\int M_x M_x / E J dx$
AB b	0	$-3/2Fx - 1/2qx^2$	0	0	0	0
BA b	0	$2Fb - 5/2Fx + 1/2qx^2$	0	0	0	0
BC b	$-x/b$	$-2Fb + Fx$	$2Fx - Fx^2/b$	x^2/b^2	$2/3Fb^2/EJ$	$1/3Xb/EJ$
CB b	$1-x/b$	$Fb + Fx$	$Fb - Fx^2/b$	$1 - 2x/b + x^2/b^2$		
CD b	-1	0	0	1	0	Xb/EJ
DC b	1	0	0	1	0	
DE b	$-1+x/b$	$-Fx$	$Fx - Fx^2/b$	$1 - 2x/b + x^2/b^2$	$1/6Fb^2/EJ$	$1/3Xb/EJ$
ED b	x/b	$Fb - Fx$	$Fx - Fx^2/b$	x^2/b^2		
EF $\sqrt{2}b$	0	$\sqrt{2}/2Fx$	0	0	0	0
FG b	0	$-1/2Fx$	0	0	0	0
GF b	0	$1/2Fb - 1/2Fx$	0	0	0	0
GA b	0	$1/2Fb - 1/2qx^2$	0	0	0	0
AG b	0	$-Fx + 1/2qx^2$	0	0	0	0
FB b	0	$Fb - Fx$	0	0	0	0
BF b	0	$-Fx$	0	0	0	0
BE b	0	0	0	0	0	0
EB b	0	0	0	0	0	0
CD	elongazione asta $N_{1,cd} \epsilon_{cd} L_{cd}$				$-Fb^2/EJ$	
	totali				$-1/6Fb^2/EJ$	$5/3Xb/EJ$
	iperstatica $X=W_{CD}$				$1/10Fb$	

Sviluppi di calcolo iperstatica

$$L_{BC}^{xx} = \int_0^b (x^2/b^2) 1/EJ dx = [1/3 x^3/b^2]_0^b 1/EJ$$

$$= (1/3 b) 1/EJ = 1/3 b/EJ$$

$$L_{CB}^{xx} = \int_0^b (1 - 2x/b + x^2/b^2) 1/EJ dx = [x - x^2/b + 1/3 x^3/b^2]_0^b 1/EJ$$

$$= (b - b + 1/3 b) 1/EJ = 1/3 b/EJ$$

$$L_{CD}^{xx} = \int_0^b (1) 1/EJ dx = [x]_0^b 1/EJ$$

$$= (b) 1/EJ = b/EJ$$

$$L_{DC}^{xx} = \int_0^b (1) 1/EJ dx = [x]_0^b 1/EJ$$

$$= (b) 1/EJ = b/EJ$$

$$L_{DE}^{xx} = \int_0^b (1 - 2x/b + x^2/b^2) 1/EJ dx = [x - x^2/b + 1/3 x^3/b^2]_0^b 1/EJ$$

$$= (b - b + 1/3 b) 1/EJ = 1/3 b/EJ$$

$$L_{ED}^{xx} = \int_0^b (x^2/b^2) 1/EJ dx = [1/3 x^3/b^2]_0^b 1/EJ$$

$$= (1/3 b) 1/EJ = 1/3 b/EJ$$

$$L_{BC}^{xo} = \int_0^b (2x/b - x^2/b^2) Fb 1/EJ dx = [x^2/b - 1/3 x^3/b^2]_0^b Fb 1/EJ$$

$$= (b - 1/3 b) Fb 1/EJ = 2/3 Fb^2/EJ$$

$$L_{CB}^{xo} = \int_0^b (1 - x^2/b^2) Fb 1/EJ dx = [x - 1/3 x^3/b^2]_0^b Fb 1/EJ$$

$$= (b - 1/3 b) Fb 1/EJ = 2/3 Fb^2/EJ$$

$$L_{DE}^{xo} = \int_0^b (x/b - x^2/b^2) Fb 1/EJ dx = [1/2 x^2/b - 1/3 x^3/b^2]_0^b Fb 1/EJ$$

$$= (1/2 b - 1/3 b) Fb 1/EJ = 1/6 Fb^2/EJ$$

$$L_{ED}^{xo} = \int_0^b (x/b - x^2/b^2) Fb 1/EJ dx = [1/2 x^2/b - 1/3 x^3/b^2]_0^b Fb 1/EJ$$

$$= (1/2 b - 1/3 b) Fb 1/EJ = 1/6 Fb^2/EJ$$

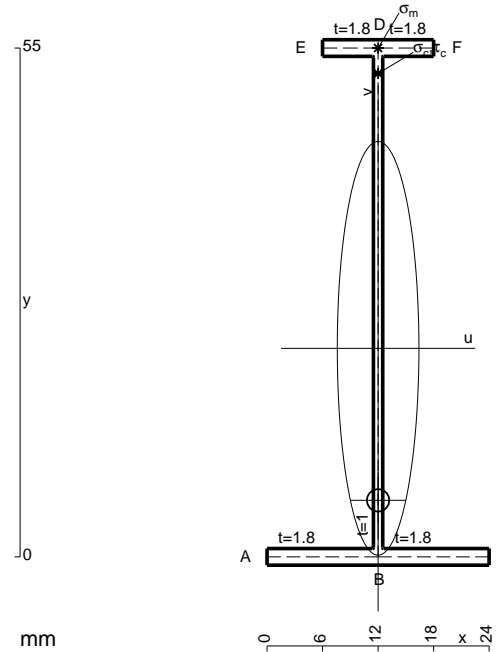

$$A = 119.8 \text{ mm}^2$$

$$J_u = 59924. \text{ mm}^4$$

$$J_v = 2333. \text{ mm}^4$$

$$J_t = 88.32 \text{ mm}^4$$

$$y_o = -16.43 \text{ mm}$$

$$y_g = 22.54 \text{ mm}$$

$$N = -220. \text{ N}$$

$$T_y = -550. \text{ N}$$

$$M_x = -431200. \text{ Nmm}$$

$$x_m = 12. \text{ mm}$$

$$y_m = 55. \text{ mm}$$

$$v_m = 32.46 \text{ mm}$$

$$\sigma_m = N/A - Mv/J_u = 231.7 \text{ N/mm}^2$$

$$y_c = 2. \text{ mm}$$

$$u_c = -12. \text{ mm}$$

$$v_c = -20.54 \text{ mm}$$

$$\sigma_c = N/A - Mv/J_u = 231.7 \text{ N/mm}^2$$

$$\tau_c = TS/tJ_u = 6.435 \text{ N/mm}^2$$

$$\tau_g = TS/tJ_u = 6.435 \text{ N/mm}^2$$

$$t_c = 220. \text{ mm}$$

$$\sigma_o = \sqrt{\sigma^2 + 3\tau^2} = 232. \text{ N/mm}^2$$

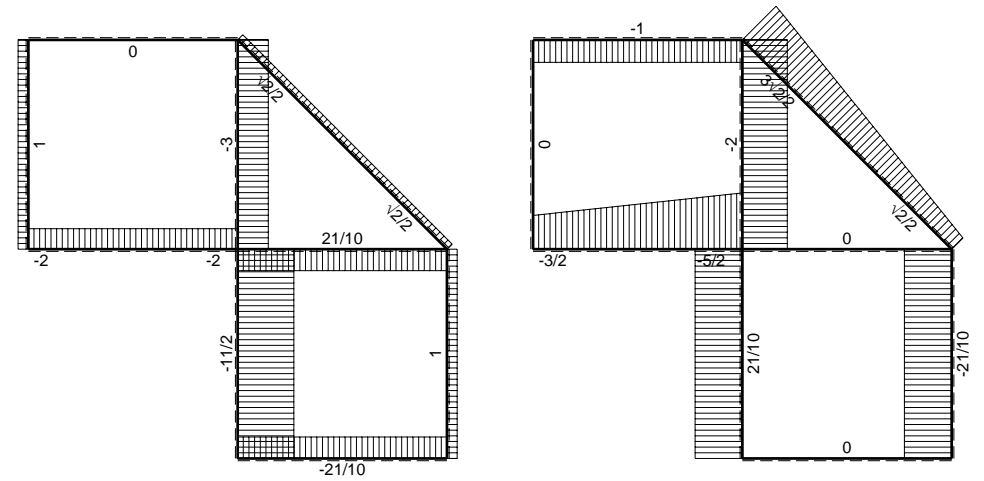
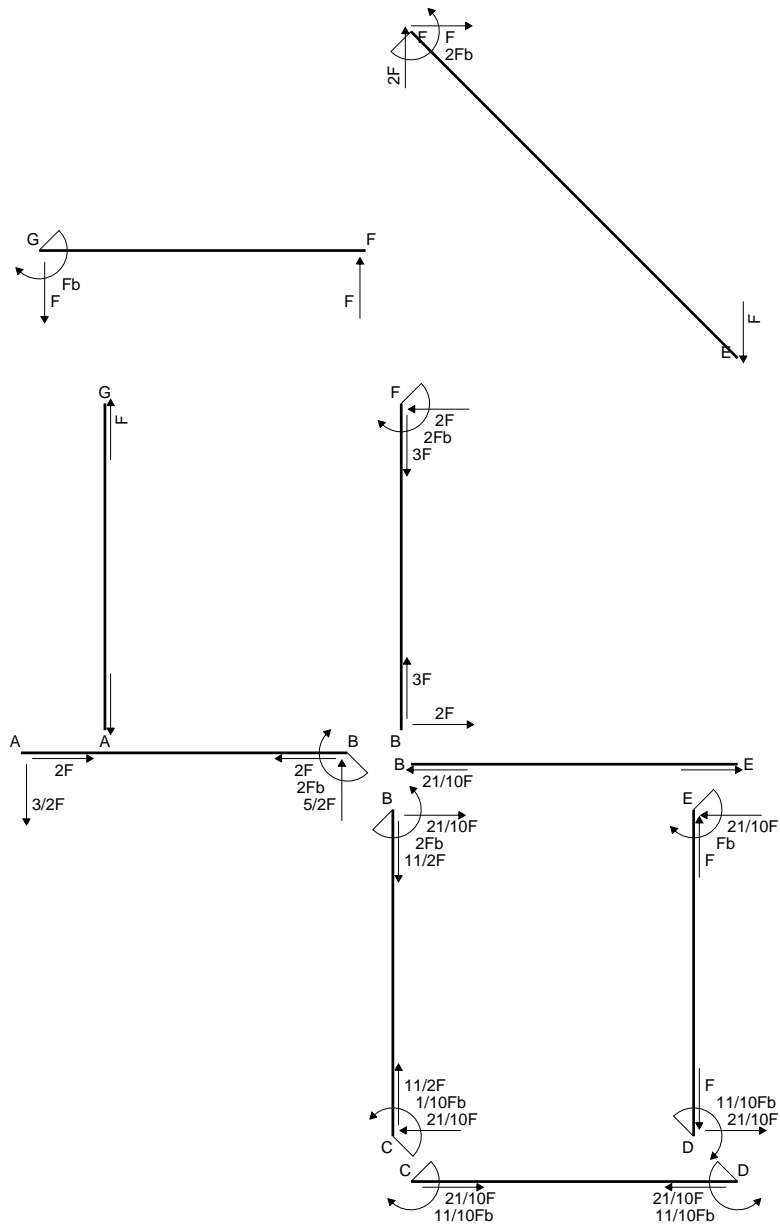

← ⊕ → F

↑ ⊕ ↓ F

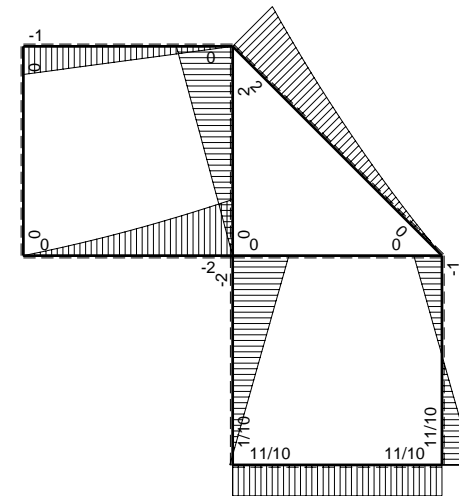

⊕ ⊖ F_b

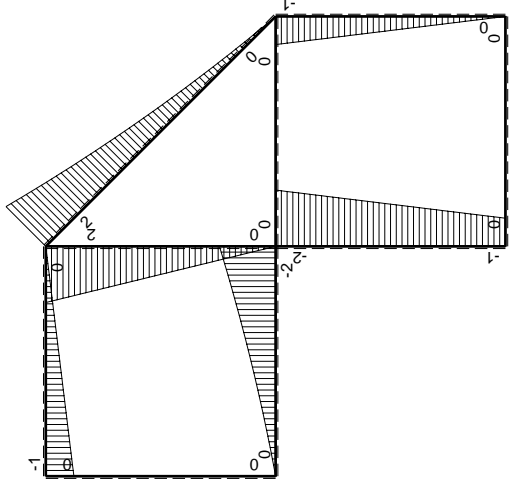
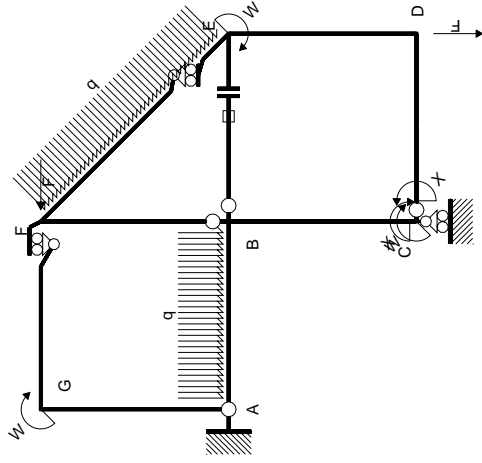

Schema di calcolo iperstatico

M_0 flessione da carichi assegnati

Quadro contribuiti PLV per iperstatica $X=W_{cd}$

\rightarrow	$M_x(x)$	$M_0(x)$	$M_x M_0$	$M_x M_x$	$\int M_x M_0 / EJ dx$	$\int X M_x M_x / EJ dx$
AB b	0	$-3/2Fx - 1/2qx^2$	0	0	0	0
BA b	0	$2Fb - 5/2Fx + 1/2qx^2$	0	0	0	0
BC b	$-x/b$	$-2Fb + Fx$	$2Fx - Fx^2/b$	x^2/b^2	$2/3Fb^2/EJ$	$1/3Xb/EJ$
CB b	$1-x/b$	$Fb + Fx$	$Fb - Fx^2/b$	$1 - 2x/b + x^2/b^2$	0	0
CD b	-1	0	0	1	0	Xb/EJ
DC b	1	0	0	1	0	0
DE b	$-1+x/b$	$-Fx$	$Fx - Fx^2/b$	$1 - 2x/b + x^2/b^2$	$1/6Fb^2/EJ$	$1/3Xb/EJ$
ED b	x/b	$Fb - Fx$	$Fx - Fx^2/b$	x^2/b^2	0	0
EF $\sqrt{2}b$	0	$\sqrt{2}/2Fx + 1/2qx^2$	0	0	0	0
FG b	0	$-Fx$	0	0	0	0
GF b	0	$Fb - Fx$	0	0	0	0
GA b	0	0	0	0	0	0
AG b	0	0	0	0	0	0
FB b	0	$2Fb - 2Fx$	0	0	0	0
BF b	0	$-2Fx$	0	0	0	0
BE b	0	0	0	0	0	0
EB b	0	0	0	0	0	0
BE	elongazione asta $N_{1, BE} \epsilon_{BE} L_{BE}$				Fb^2/EJ	
	totali				$11/6Fb^2/EJ$	$5/3Xb/EJ$
	iperstatica $X=W_{cd}$				$-11/10Fb$	

Sviluppi di calcolo iperstatica

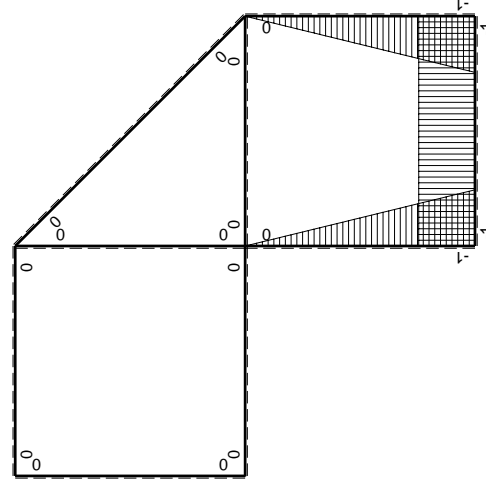

M_x flessione da iperstatica $X=1$

$$L_{BC}^{xx} = \int_0^b (x^2/b^2) 1/EJ dx = [1/3 x^3/b^2]_0^b 1/EJ$$

$$= (1/3 b) 1/EJ = 1/3 b/EJ$$

$$L_{CB}^{xx} = \int_0^b (1 - 2x/b + x^2/b^2) 1/EJ dx = [x - x^2/b + 1/3 x^3/b^2]_0^b 1/EJ$$

$$= (b - b + 1/3 b) 1/EJ = 1/3 b/EJ$$

$$L_{CD}^{xx} = \int_0^b (1) 1/EJ dx = [x]_0^b 1/EJ$$

$$= (b) 1/EJ = b/EJ$$

$$L_{DC}^{xx} = \int_0^b (1) 1/EJ dx = [x]_0^b 1/EJ$$

$$= (b) 1/EJ = b/EJ$$

$$L_{DE}^{xx} = \int_0^b (1 - 2x/b + x^2/b^2) 1/EJ dx = [x - x^2/b + 1/3 x^3/b^2]_0^b 1/EJ$$

$$= (b - b + 1/3 b) 1/EJ = 1/3 b/EJ$$

$$L_{ED}^{xx} = \int_0^b (x^2/b^2) 1/EJ dx = [1/3 x^3/b^2]_0^b 1/EJ$$

$$= (1/3 b) 1/EJ = 1/3 b/EJ$$

$$L_{BC}^{x_0} = \int_0^b (2x/b - x^2/b^2) Fb 1/EJ dx = [x^2/b - 1/3 x^3/b^2]_0^b Fb 1/EJ$$

$$= (b - 1/3 b) Fb 1/EJ = 2/3 Fb^2/EJ$$

$$L_{CB}^{x_0} = \int_0^b (1 - x^2/b^2) Fb 1/EJ dx = [x - 1/3 x^3/b^2]_0^b Fb 1/EJ$$

$$= (b - 1/3 b) Fb 1/EJ = 2/3 Fb^2/EJ$$

$$L_{DE}^{x_0} = \int_0^b (x/b - x^2/b^2) Fb 1/EJ dx = [1/2 x^2/b - 1/3 x^3/b^2]_0^b Fb 1/EJ$$

$$= (1/2 b - 1/3 b) Fb 1/EJ = 1/6 Fb^2/EJ$$

$$L_{ED}^{x_0} = \int_0^b (x/b - x^2/b^2) Fb 1/EJ dx = [1/2 x^2/b - 1/3 x^3/b^2]_0^b Fb 1/EJ$$

$$= (1/2 b - 1/3 b) Fb 1/EJ = 1/6 Fb^2/EJ$$

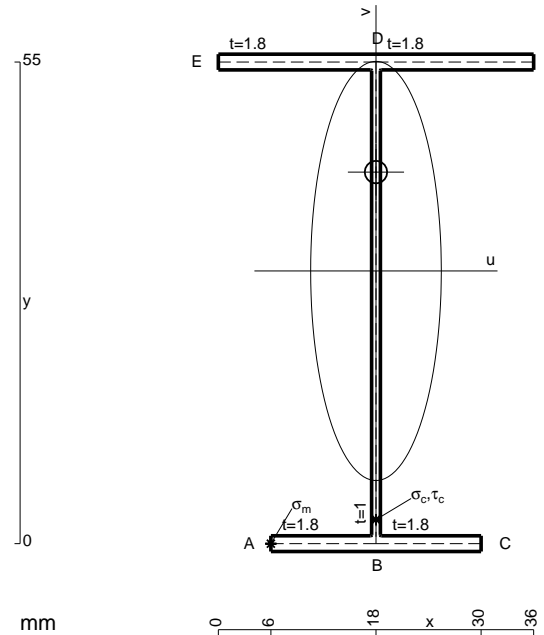

- A = 163. mm²
- J_u = 93375. mm⁴
- J_v = 9072. mm⁴
- J_i = 135. mm⁴
- y_o = 11.28 mm
- y_g = 31.14 mm
- N = -1100. N
- T_y = -1375. N
- M_x = -572000. Nmm
- x_m = 6. mm
- u_m = -12. mm
- v_m = -31.14 mm
- σ_m = N/A-Mv/J_u = -197.5 N/mm²
- x_c = 18. mm
- v_c = -31.14 mm
- σ_c = N/A-Mv/J_u = -197.5 N/mm²
- τ_c = TS^{*}/tJ_u = 19.81 N/mm²
- τ_g = TS^{*}/tJ_u = 19.81 N/mm²
- t_c = 550. mm
- σ_o = √σ²+3τ² = 200.5 N/mm²

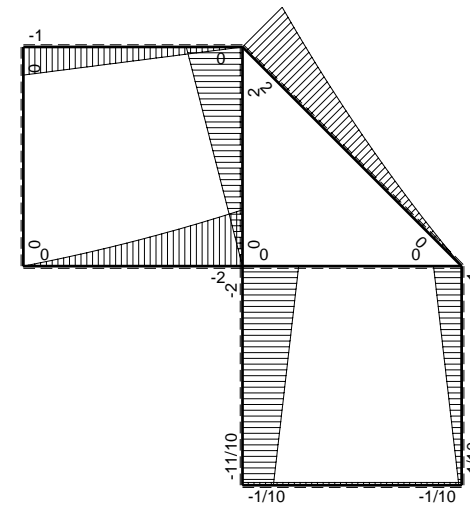
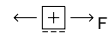
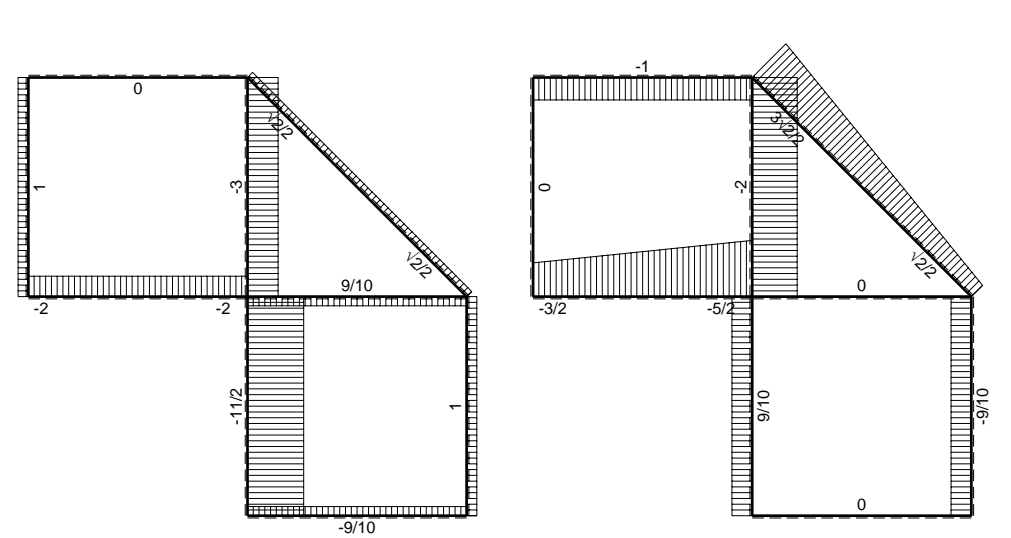
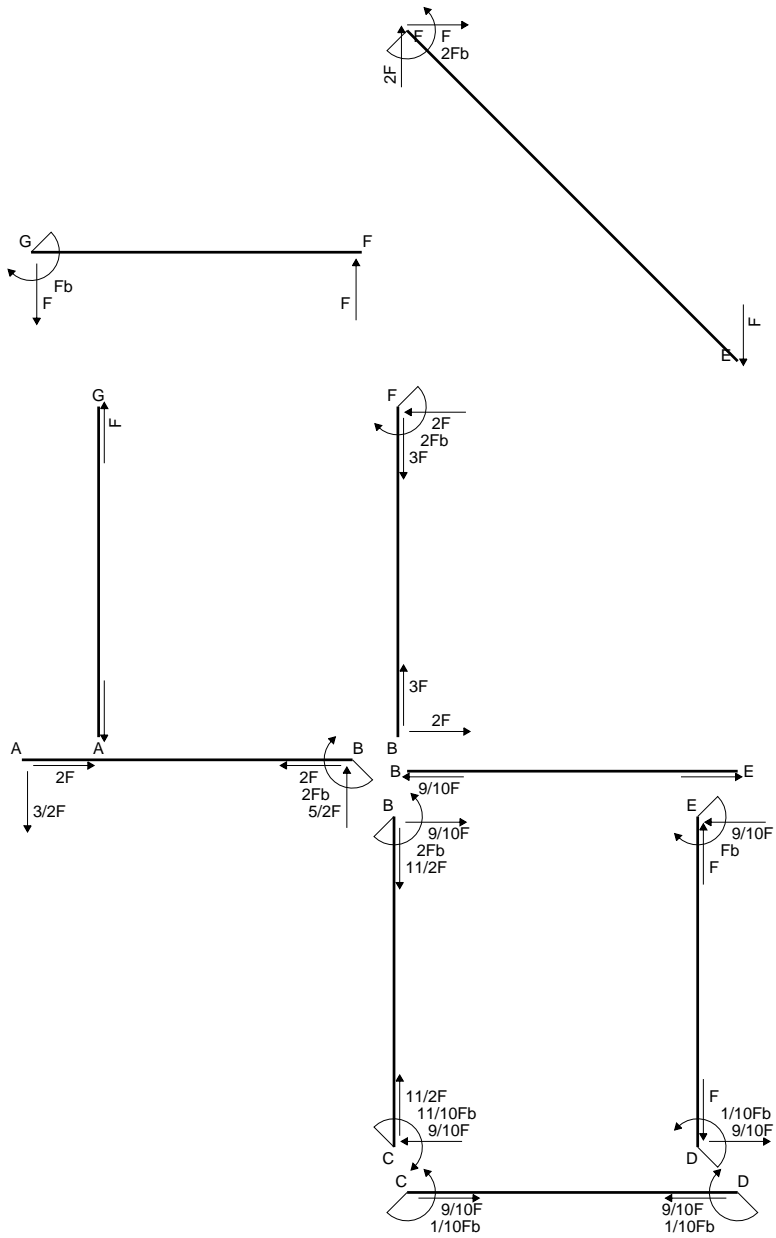

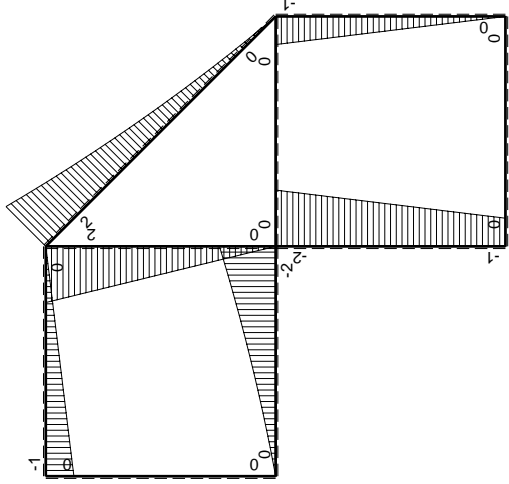
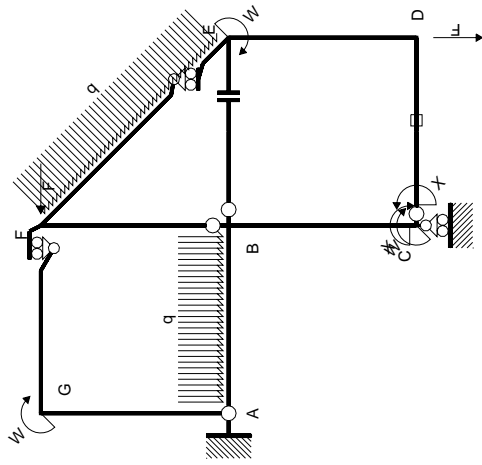

Schema di calcolo iperstatico

M_0 flessione da carichi assegnati

Quadro contribuiti PLV per iperstatica $X=W_{cd}$

\rightarrow	$M_x(x)$	$M_0(x)$	$M_x M_0$	$M_x M_x$	$\int M_x M_0 / EJ dx$	$\int M_x M_x / EJ dx$
AB b	0	$-3/2Fx - 1/2qx^2$	0	0	0	0
BA b	0	$2Fb - 5/2Fx + 1/2qx^2$	0	0	0	0
BC b	$-x/b$	$-2Fb + Fx$	$2Fx - Fx^2/b$	x^2/b^2	$2/3Fb^2/EJ$	$1/3Xb/EJ$
CB b	$1-x/b$	$Fb + Fx$	$Fb - Fx^2/b$	$1 - 2x/b + x^2/b^2$	0	0
CD b	-1	0	0	1	0	Xb/EJ
DC b	1	0	0	1	0	0
DE b	$-1+x/b$	-Fx	$Fx - Fx^2/b$	$1 - 2x/b + x^2/b^2$	$1/6Fb^2/EJ$	$1/3Xb/EJ$
ED b	x/b	$Fb - Fx$	$Fx - Fx^2/b$	x^2/b^2	0	0
EF $\sqrt{2}b$	0	$\sqrt{2}/2Fx + 1/2qx^2$	0	0	0	0
FG b	0	-Fx	0	0	0	0
GF b	0	$Fb - Fx$	0	0	0	0
GA b	0	0	0	0	0	0
AG b	0	0	0	0	0	0
FB b	0	$2Fb - 2Fx$	0	0	0	0
BF b	0	-2Fx	0	0	0	0
BE b	0	0	0	0	0	0
EB b	0	0	0	0	0	0
CD	elongazione asta $N_{1,cd} \epsilon_{cd} L_{cd}$				$-Fb^2/EJ$	
	totali				$-1/6Fb^2/EJ$	$5/3Xb/EJ$
	iperstatica $X=W_{cd}$				$1/10Fb$	

Sviluppi di calcolo iperstatica

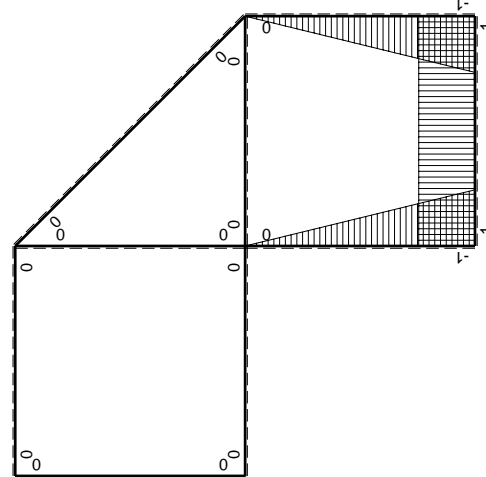

M_x flessione da iperstatica $X=1$

$$L_{BC}^{xx} = \int_0^b (x^2/b^2) 1/EJ dx = [1/3 x^3/b^2]_0^b 1/EJ$$

$$= (1/3 b) 1/EJ = 1/3 b/EJ$$

$$L_{CB}^{xx} = \int_0^b (1 - 2x/b + x^2/b^2) 1/EJ dx = [x - x^2/b + 1/3 x^3/b^2]_0^b 1/EJ$$

$$= (b - b + 1/3 b) 1/EJ = 1/3 b/EJ$$

$$L_{CD}^{xx} = \int_0^b (1) 1/EJ dx = [x]_0^b 1/EJ$$

$$= (b) 1/EJ = b/EJ$$

$$L_{DC}^{xx} = \int_0^b (1) 1/EJ dx = [x]_0^b 1/EJ$$

$$= (b) 1/EJ = b/EJ$$

$$L_{DE}^{xx} = \int_0^b (1 - 2x/b + x^2/b^2) 1/EJ dx = [x - x^2/b + 1/3 x^3/b^2]_0^b 1/EJ$$

$$= (b - b + 1/3 b) 1/EJ = 1/3 b/EJ$$

$$L_{ED}^{xx} = \int_0^b (x^2/b^2) 1/EJ dx = [1/3 x^3/b^2]_0^b 1/EJ$$

$$= (1/3 b) 1/EJ = 1/3 b/EJ$$

$$L_{BC}^{x_0} = \int_0^b (2x/b - x^2/b^2) Fb 1/EJ dx = [x^2/b - 1/3 x^3/b^2]_0^b Fb 1/EJ$$

$$= (b - 1/3 b) Fb 1/EJ = 2/3 Fb^2/EJ$$

$$L_{CB}^{x_0} = \int_0^b (1 - x^2/b^2) Fb 1/EJ dx = [x - 1/3 x^3/b^2]_0^b Fb 1/EJ$$

$$= (b - 1/3 b) Fb 1/EJ = 2/3 Fb^2/EJ$$

$$L_{DE}^{x_0} = \int_0^b (x/b - x^2/b^2) Fb 1/EJ dx = [1/2 x^2/b - 1/3 x^3/b^2]_0^b Fb 1/EJ$$

$$= (1/2 b - 1/3 b) Fb 1/EJ = 1/6 Fb^2/EJ$$

$$L_{ED}^{x_0} = \int_0^b (x/b - x^2/b^2) Fb 1/EJ dx = [1/2 x^2/b - 1/3 x^3/b^2]_0^b Fb 1/EJ$$

$$= (1/2 b - 1/3 b) Fb 1/EJ = 1/6 Fb^2/EJ$$

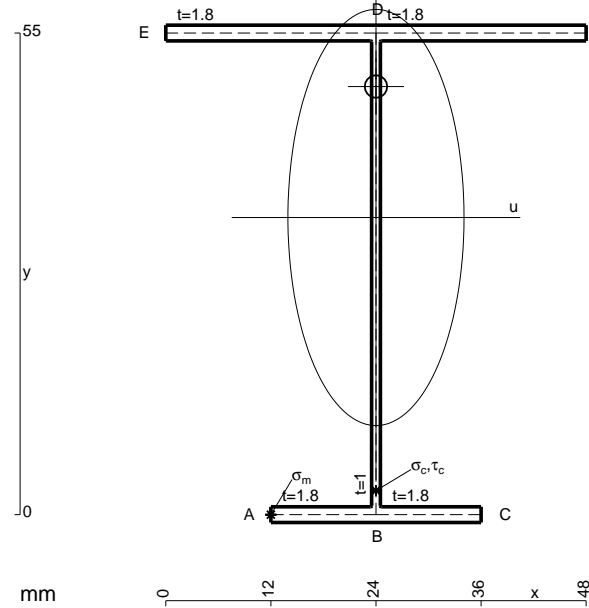

- A = 184.6 mm²
- J_u = 104229. mm⁴
- J_v = 18662. mm⁴
- J_t = 158.3 mm⁴
- y_o = 14.95 mm
- y_g = 33.94 mm
- N = -1080. N
- T_y = -1350. N
- M_x = -615600. Nmm
- x_m = 12. mm
- u_m = -12. mm
- v_m = -33.94 mm
- σ_m = N/A-Mv/J_u = -206.3 N/mm²
- x_c = 24. mm
- v_c = -33.94 mm
- σ_c = N/A-Mv/J_u = -206.3 N/mm²
- τ_c = TS^{*}/tJ_u = 18.99 N/mm²
- τ_g = TS^{*}/tJ_u = 18.99 N/mm²
- t_c = 540. mm
- σ_o = √σ²+3τ² = 208.9 N/mm²

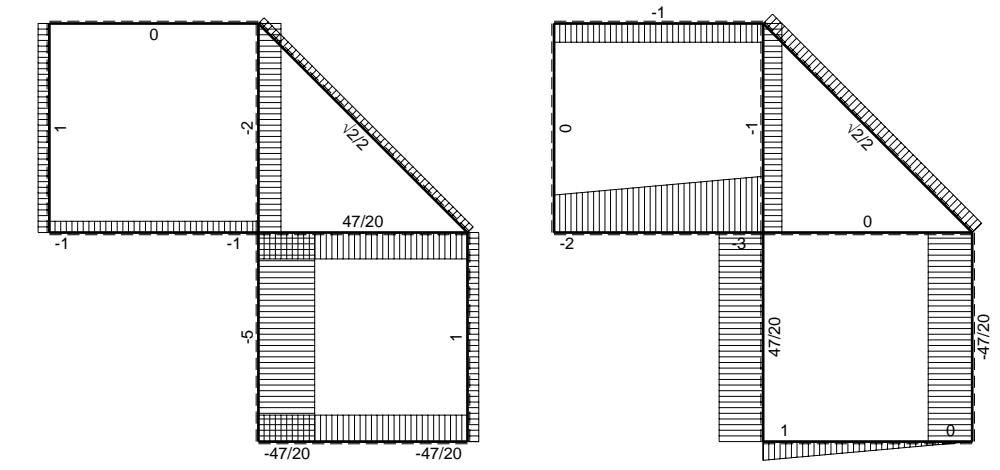
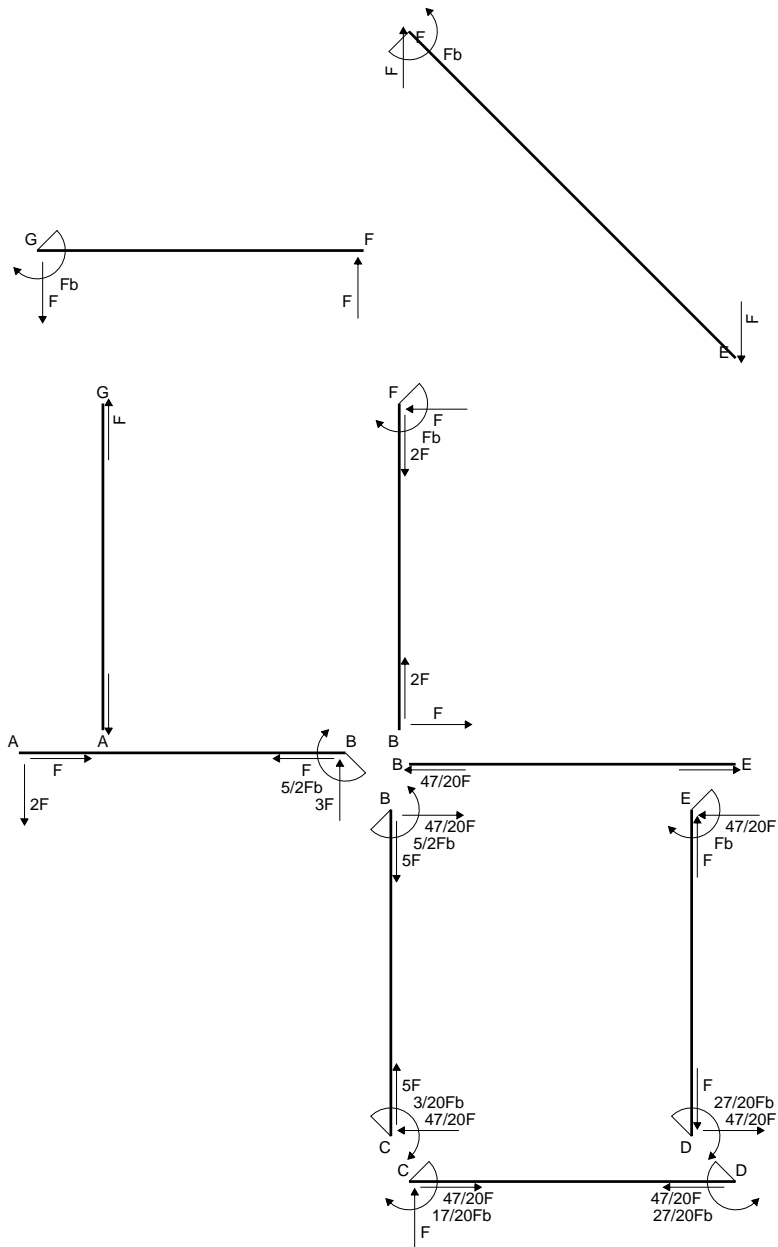

← ⊕ → F

↑ ⊕ ↓ F

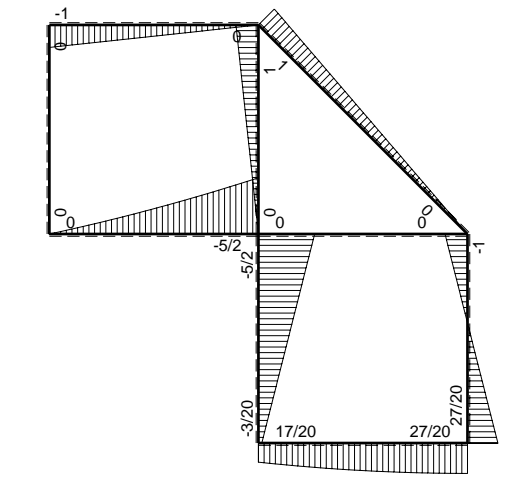

⊕ ⊖ F_b

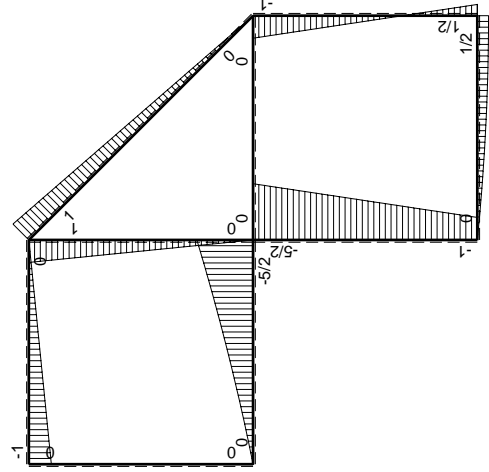
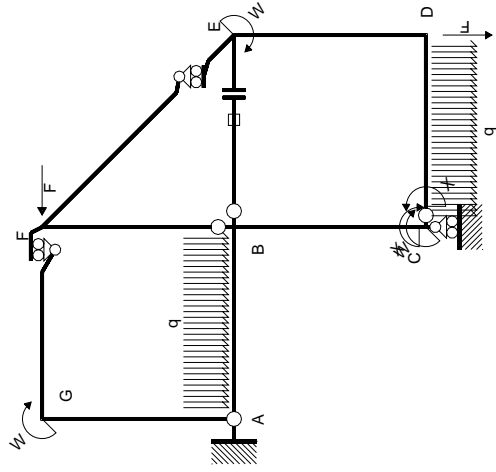

Schema di calcolo iperstatico

M_0 flessione da carichi assegnati

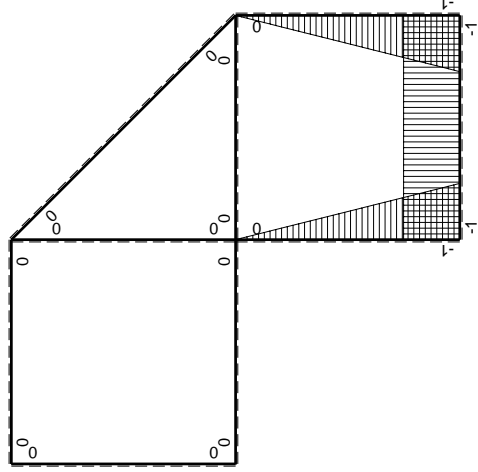

M_x flessione da iperstatica X=1

Quadro contributi PLV per iperstatica X=W_{cd}

→	$M_x(x)$	$M_0(x)$	$M_x M_0$	$M_x M_x$	$\int M_x M_0 / EJ dx$	$\int X M_x M_x / EJ dx$
AB b	0	$-2Fx - 1/2qx^2$	0	0	0	0
BA b	0	$5/2Fb - 3Fx + 1/2qx^2$	0	0	0	0
BC b	$-x/b$	$-5/2Fb + 3/2Fx$	$5/2Fx - 3/2Fx^2/b$	x^2/b^2	$3/4Fb^2/EJ$	$1/3Xb/EJ$
CB b	$1-x/b$	$Fb + 3/2Fx$	$Fb + 1/2Fx - 3/2Fx^2/b$	$1 - 2x/b + x^2/b^2$	$-1/3Fb^2/EJ$	Xb/EJ
CD b	-1	$Fx - 1/2qx^2$	$-Fx + 1/2Fx^2/b$	1		
DC b	1	$-1/2Fb + 1/2qx^2$	$-1/2Fb + 1/2Fx^2/b$	1		
DE b	$-1 + x/b$	$1/2Fb - 3/2Fx$	$-1/2Fb + 2Fx - 3/2Fx^2/b$	$1 - 2x/b + x^2/b^2$	0	$1/3Xb/EJ$
ED b	x/b	$Fb - 3/2Fx$	$Fx - 3/2Fx^2/b$	x^2/b^2	0	0
EF $\sqrt{2}b$	0	$\sqrt{2}/2Fx$	0	0	0	0
FG b	0	-Fx	0	0	0	0
GF b	0	$Fb - Fx$	0	0	0	0
GA b	0	0	0	0	0	0
AG b	0	0	0	0	0	0
FB b	0	$Fb - Fx$	0	0	0	0
BF b	0	-Fx	0	0	0	0
BE b	0	0	0	0	0	0
EB b	0	0	0	0	0	0
BE	elongazione asta $N_{1, BE} \epsilon_{BE} L_{BE}$				Fb^2/EJ	
	totali				$17/12Fb^2/EJ$	$5/3Xb/EJ$
	iperstatica X=W _{cd}				$-17/20Fb$	

Sviluppi di calcolo iperstatica

$$L_{BC}^{xx} = \int_0^b (x^2/b^2) 1/EJ dx = [1/3 x^3/b^2]_0^b 1/EJ$$

$$= (1/3 b) 1/EJ = 1/3 b/EJ$$

$$L_{CB}^{xx} = \int_0^b (1 - 2x/b + x^2/b^2) 1/EJ dx = [x - x^2/b + 1/3 x^3/b^2]_0^b 1/EJ$$

$$= (b - b + 1/3 b) 1/EJ = 1/3 b/EJ$$

$$L_{CD}^{xx} = \int_0^b (1) 1/EJ dx = [x]_0^b 1/EJ$$

$$= (b) 1/EJ = b/EJ$$

$$L_{DC}^{xx} = \int_0^b (1) 1/EJ dx = [x]_0^b 1/EJ$$

$$= (b) 1/EJ = b/EJ$$

$$L_{DE}^{xx} = \int_0^b (1 - 2x/b + x^2/b^2) 1/EJ dx = [x - x^2/b + 1/3 x^3/b^2]_0^b 1/EJ$$

$$= (b - b + 1/3 b) 1/EJ = 1/3 b/EJ$$

$$L_{ED}^{xx} = \int_0^b (x^2/b^2) 1/EJ dx = [1/3 x^3/b^2]_0^b 1/EJ$$

$$= (1/3 b) 1/EJ = 1/3 b/EJ$$

$$L_{BC}^{xo} = \int_0^b (5/2 x/b - 3/2 x^2/b^2) Fb 1/EJ dx = [5/4 x^2/b - 1/2 x^3/b^2]_0^b Fb 1/EJ$$

$$= (5/4 b - 1/2 b) Fb 1/EJ = 3/4 Fb^2/EJ$$

$$L_{CB}^{xo} = \int_0^b (1 + 1/2 x/b - 3/2 x^2/b^2) Fb 1/EJ dx = [x + 1/4 x^2/b - 1/2 x^3/b^2]_0^b Fb 1/EJ$$

$$= (b + 1/4 b - 1/2 b) Fb 1/EJ = 3/4 Fb^2/EJ$$

$$L_{CD}^{xo} = \int_0^b (-x/b + 1/2 x^2/b^2) Fb 1/EJ dx = [-1/2 x^2/b + 1/6 x^3/b^2]_0^b Fb 1/EJ$$

$$= (-1/2 b + 1/6 b) Fb 1/EJ = -1/3 Fb^2/EJ$$

$$L_{DC}^{xo} = \int_0^b (-1/2 + 1/2 x^2/b^2) Fb 1/EJ dx = [-1/2 x + 1/6 x^3/b^2]_0^b Fb 1/EJ$$

$$= (-1/2 b + 1/6 b) Fb 1/EJ = -1/3 Fb^2/EJ$$

$$L_{DE}^{xo} = \int_0^b (-1/2 + 2x/b - 3/2 x^2/b^2) Fb 1/EJ dx = [-1/2 x + x^2/b - 1/2 x^3/b^2]_0^b Fb 1/EJ$$

$$= (-1/2 b + b - 1/2 b) Fb 1/EJ = 0$$

$$L_{ED}^{xo} = \int_0^b (x/b - 3/2 x^2/b^2) Fb 1/EJ dx = [1/2 x^2/b - 1/2 x^3/b^2]_0^b Fb 1/EJ$$

$$= (1/2 b - 1/2 b) Fb 1/EJ = 0$$

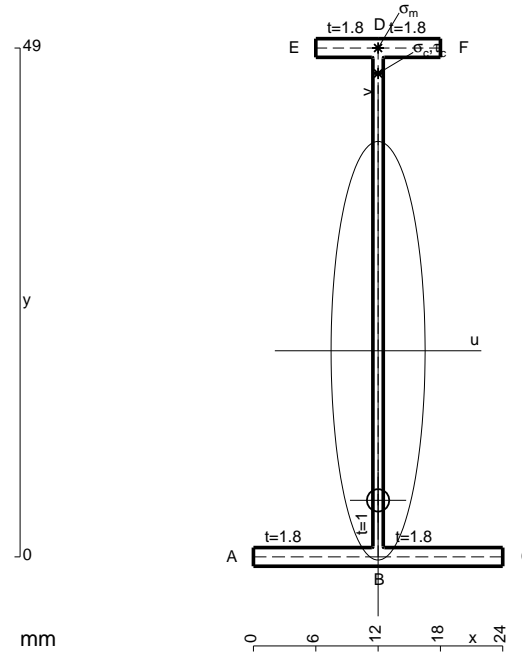

$$A = 113.8 \text{ mm}^2$$

$$J_u = 46239. \text{ mm}^4$$

$$J_v = 2333. \text{ mm}^4$$

$$J_t = 86.32 \text{ mm}^4$$

$$y_o = -14.41 \text{ mm}$$

$$y_g = 19.85 \text{ mm}$$

$$N = -250. \text{ N}$$

$$T_y = -750. \text{ N}$$

$$M_x = -343750. \text{ Nmm}$$

$$x_m = 12. \text{ mm}$$

$$y_m = 49. \text{ mm}$$

$$v_m = 29.15 \text{ mm}$$

$$\sigma_m = N/A - Mv/J_u = 214.5 \text{ N/mm}^2$$

$$y_c = 2. \text{ mm}$$

$$u_c = -12. \text{ mm}$$

$$v_c = -17.85 \text{ mm}$$

$$\sigma_c = N/A - Mv/J_u = 214.5 \text{ N/mm}^2$$

$$\tau_c = TS/tJ_u = 10.21 \text{ N/mm}^2$$

$$\tau_g = TS/tJ_u = 10.21 \text{ N/mm}^2$$

$$t_c = 250. \text{ mm}$$

$$\sigma_o = \sqrt{\sigma^2 + 3\tau^2} = 215.2 \text{ N/mm}^2$$

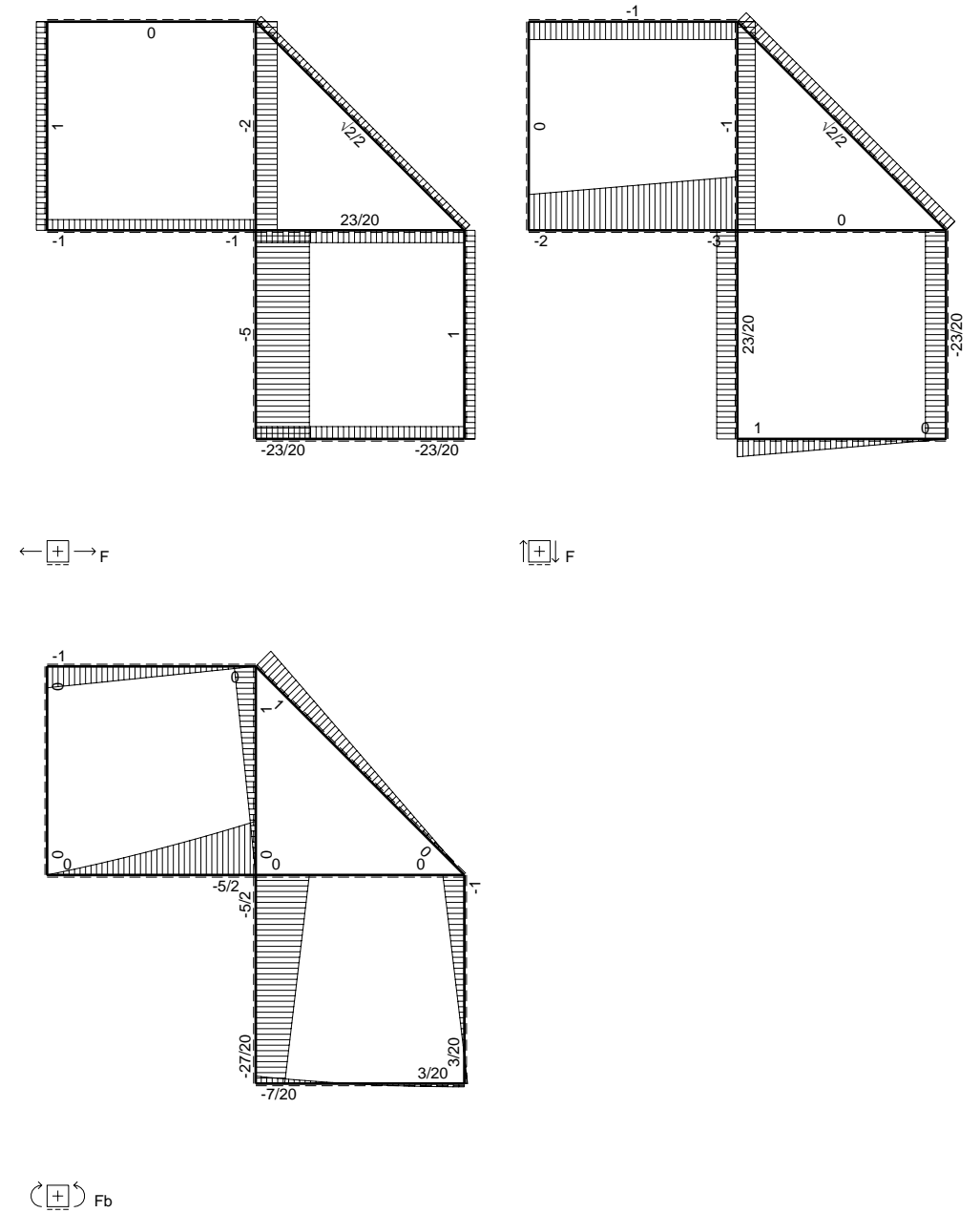
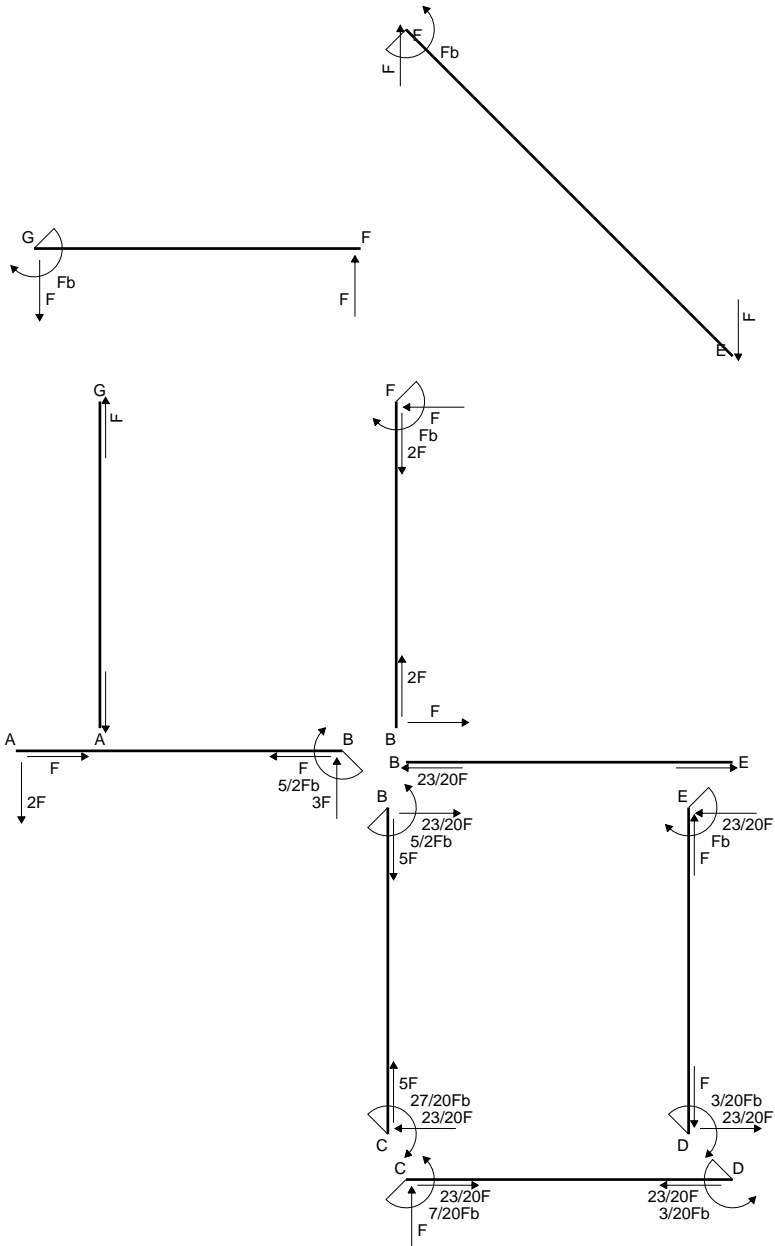

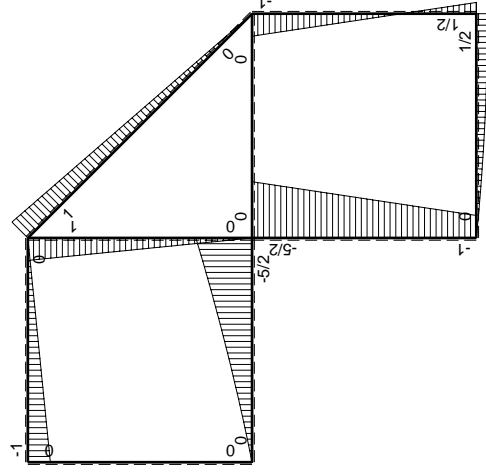
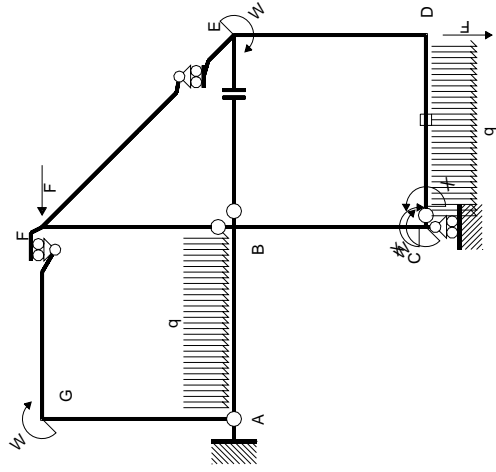

Schema di calcolo iperstatico

M_0 flessione da carichi assegnati

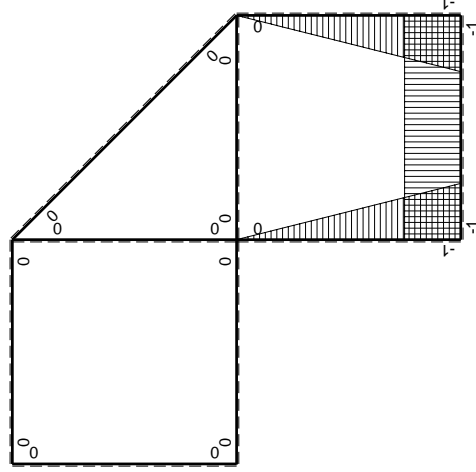

M_x flessione da iperstatica X=1

Quadro contributi PLV per iperstatica X=W_{CD}

→	$M_x(x)$	$M_0(x)$	$M_x M_0$	$M_x M_x$	$\int M_x M_0 / EJ dx$	$\int X M_x M_x / EJ dx$
AB b	0	$-2Fx - 1/2qx^2$	0	0	0	0
BA b	0	$5/2Fb - 3Fx + 1/2qx^2$	0	0	0	0
BC b	$-x/b$	$-5/2Fb + 3/2Fx$	$5/2Fx - 3/2Fx^2/b$	x^2/b^2	$3/4Fb^2/EJ$	$1/3Xb/EJ$
CB b	$1-x/b$	$Fb + 3/2Fx$	$Fb + 1/2Fx - 3/2Fx^2/b$	$1 - 2x/b + x^2/b^2$	$-1/3Fb^2/EJ$	Xb/EJ
CD b	-1	$Fx - 1/2qx^2$	$-Fx + 1/2Fx^2/b$	1		
DC b	1	$-1/2Fb + 1/2qx^2$	$-1/2Fb + 1/2Fx^2/b$	1		
DE b	$-1 + x/b$	$1/2Fb - 3/2Fx$	$-1/2Fb + 2Fx - 3/2Fx^2/b$	$1 - 2x/b + x^2/b^2$	0	$1/3Xb/EJ$
ED b	x/b	$Fb - 3/2Fx$	$Fx - 3/2Fx^2/b$	x^2/b^2	0	0
EF $\sqrt{2}b$	0	$\sqrt{2}/2Fx$	0	0	0	0
FG b	0	-Fx	0	0	0	0
GF b	0	$Fb - Fx$	0	0	0	0
GA b	0	0	0	0	0	0
AG b	0	0	0	0	0	0
FB b	0	$Fb - Fx$	0	0	0	0
BF b	0	-Fx	0	0	0	0
BE b	0	0	0	0	0	0
EB b	0	0	0	0	0	0
CD	elongazione asta $N_{1,cd} \epsilon_{cd} L_{cd}$				$-Fb^2/EJ$	
	totali				$-7/12Fb^2/EJ$	$5/3Xb/EJ$
	iperstatica X=W _{CD}				$7/20Fb$	

Sviluppi di calcolo iperstatica

$$L_{BC}^{xx} = \int_0^b (x^2/b^2) 1/EJ dx = [1/3 x^3/b^2]_0^b 1/EJ$$

$$= (1/3 b) 1/EJ = 1/3 b/EJ$$

$$L_{CB}^{xx} = \int_0^b (1 - 2x/b + x^2/b^2) 1/EJ dx = [x - x^2/b + 1/3 x^3/b^2]_0^b 1/EJ$$

$$= (b - b + 1/3 b) 1/EJ = 1/3 b/EJ$$

$$L_{CD}^{xx} = \int_0^b (1) 1/EJ dx = [x]_0^b 1/EJ$$

$$= (b) 1/EJ = b/EJ$$

$$L_{DC}^{xx} = \int_0^b (1) 1/EJ dx = [x]_0^b 1/EJ$$

$$= (b) 1/EJ = b/EJ$$

$$L_{DE}^{xx} = \int_0^b (1 - 2x/b + x^2/b^2) 1/EJ dx = [x - x^2/b + 1/3 x^3/b^2]_0^b 1/EJ$$

$$= (b - b + 1/3 b) 1/EJ = 1/3 b/EJ$$

$$L_{ED}^{xx} = \int_0^b (x^2/b^2) 1/EJ dx = [1/3 x^3/b^2]_0^b 1/EJ$$

$$= (1/3 b) 1/EJ = 1/3 b/EJ$$

$$L_{BC}^{xo} = \int_0^b (5/2 x/b - 3/2 x^2/b^2) Fb 1/EJ dx = [5/4 x^2/b - 1/2 x^3/b^2]_0^b Fb 1/EJ$$

$$= (5/4 b - 1/2 b) Fb 1/EJ = 3/4 Fb^2/EJ$$

$$L_{CB}^{xo} = \int_0^b (1 + 1/2 x/b - 3/2 x^2/b^2) Fb 1/EJ dx = [x + 1/4 x^2/b - 1/2 x^3/b^2]_0^b Fb 1/EJ$$

$$= (b + 1/4 b - 1/2 b) Fb 1/EJ = 3/4 Fb^2/EJ$$

$$L_{CD}^{xo} = \int_0^b (-x/b + 1/2 x^2/b^2) Fb 1/EJ dx + 1 (-1) 1 Fb^2/EJ$$

$$= [-1/2 x^2/b + 1/6 x^3/b^2]_0^b Fb 1/EJ + 1 (-1) 1 Fb^2/EJ$$

$$= (-1/2 b + 1/6 b) Fb 1/EJ + 1 (-1) 1 Fb^2/EJ = -4/3 Fb^2/EJ$$

$$L_{DC}^{xo} = \int_0^b (-1/2 + 1/2 x^2/b^2) Fb 1/EJ dx + 1 (-1) 1 Fb^2/EJ$$

$$= [-1/2 x + 1/6 x^3/b^2]_0^b Fb 1/EJ + 1 (-1) 1 Fb^2/EJ$$

$$= (-1/2 b + 1/6 b) Fb 1/EJ + 1 (-1) 1 Fb^2/EJ = -4/3 Fb^2/EJ$$

$$L_{DE}^{xo} = \int_0^b (-1/2 + 2x/b - 3/2 x^2/b^2) Fb 1/EJ dx = [-1/2 x + x^2/b - 1/2 x^3/b^2]_0^b Fb 1/EJ$$

$$= (-1/2 b + b - 1/2 b) Fb 1/EJ = 0$$

$$L_{ED}^{xo} = \int_0^b (x/b - 3/2 x^2/b^2) Fb 1/EJ dx = [1/2 x^2/b - 1/2 x^3/b^2]_0^b Fb 1/EJ$$

$$= (1/2 b - 1/2 b) Fb 1/EJ = 0$$

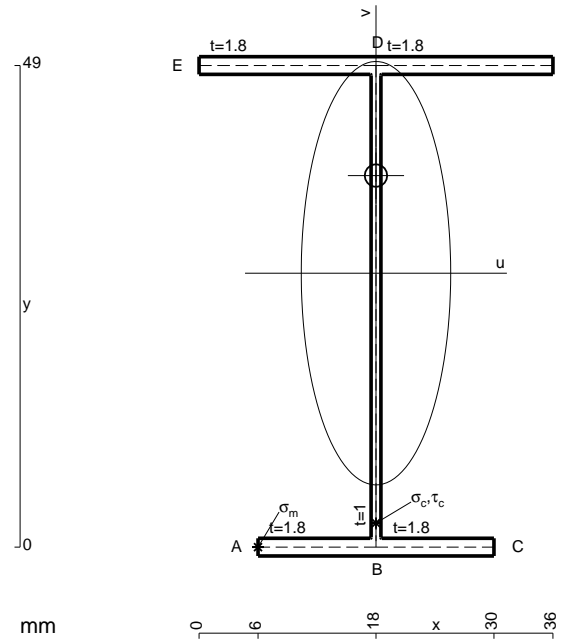

- A = 157. mm²
- J_u = 72847. mm⁴
- J_v = 9072. mm⁴
- J_t = 133. mm⁴
- y_o = 9.929 mm
- y_g = 27.87 mm
- N = -400. N
- T_y = -1200. N
- M_x = -590000. Nmm
- x_m = 6. mm
- u_m = -12. mm
- v_m = -27.87 mm
- σ_m = N/A-Mv/J_u = -228.3 N/mm²
- x_c = 18. mm
- v_c = -27.87 mm
- σ_c = N/A-Mv/J_u = -228.3 N/mm²
- τ_c = TS/tJ_u = 19.83 N/mm²
- τ_g = TS/tJ_u = 19.83 N/mm²
- t_c = 400. mm
- σ_o = √σ²+3τ² = 230.8 N/mm²

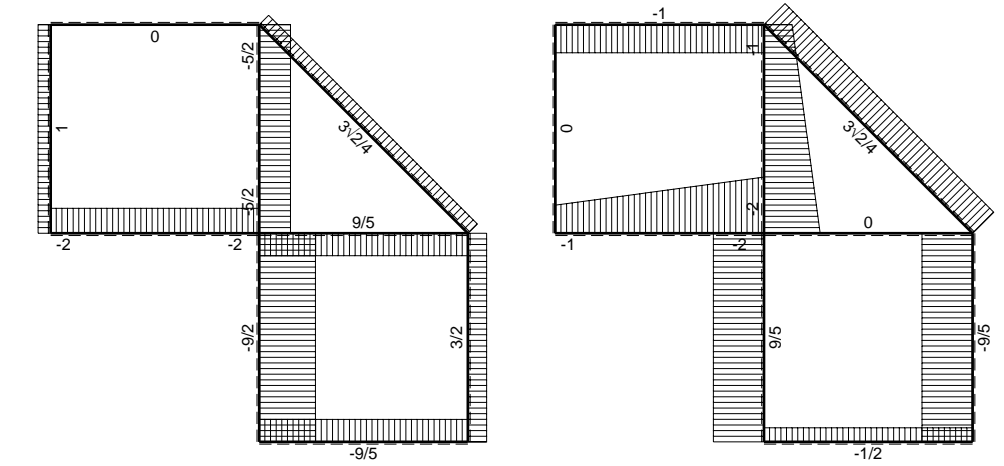
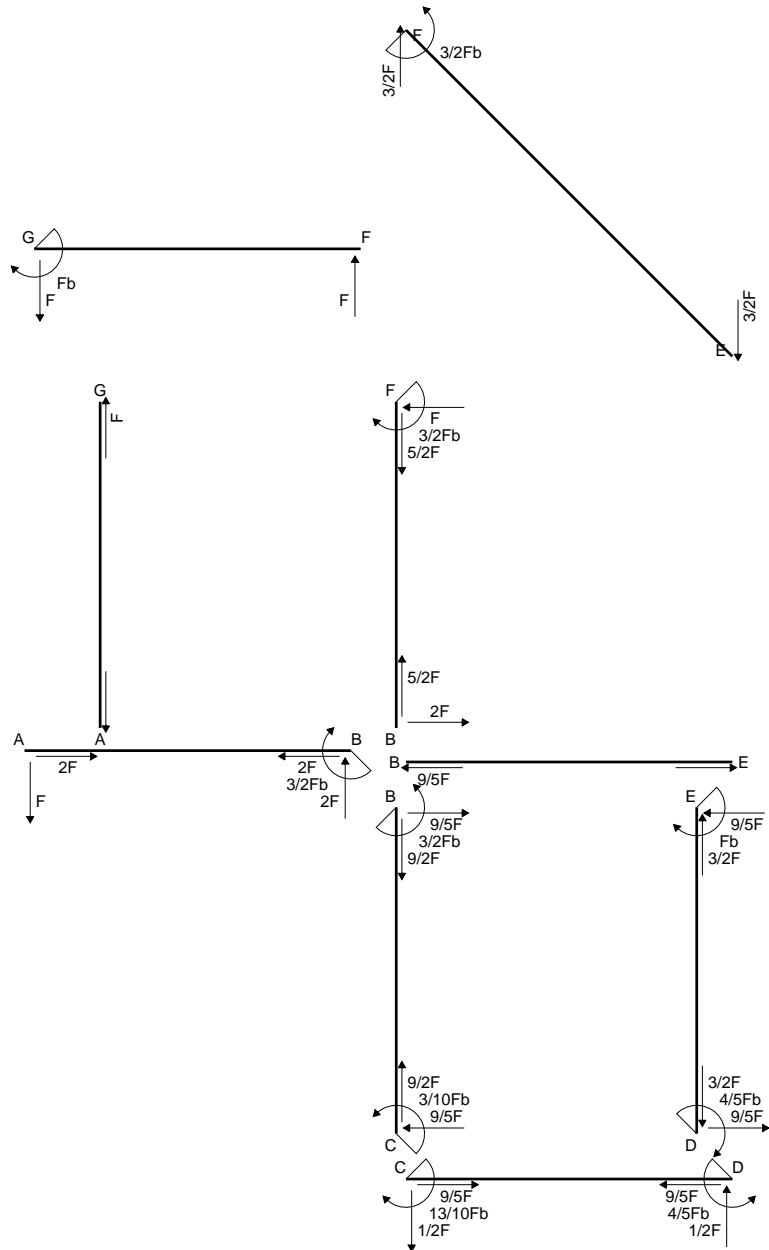

← ⊕ → F

↑ ⊕ ↓ F

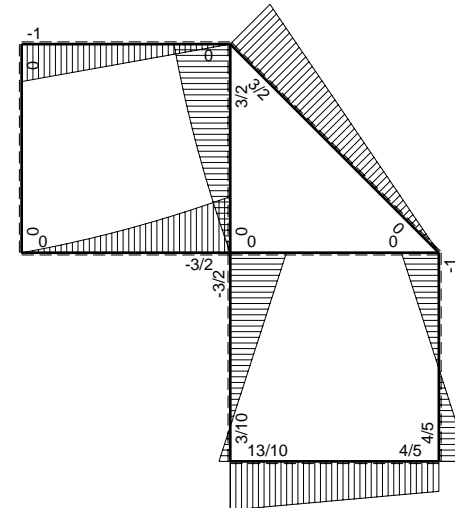

⊕ ⊖ F_b

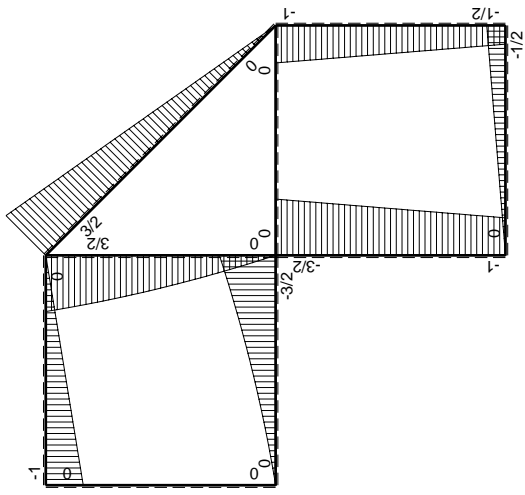
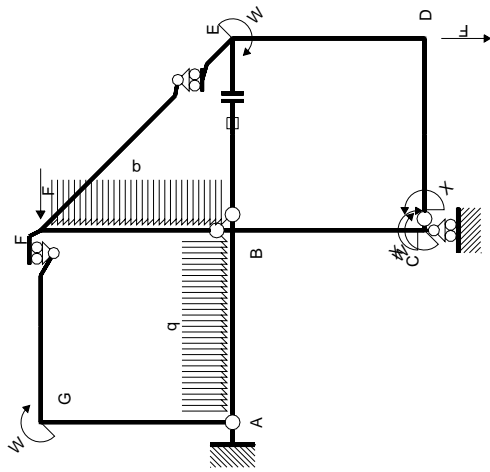

Schema di calcolo iperstatico

M_0 flessione da carichi assegnati

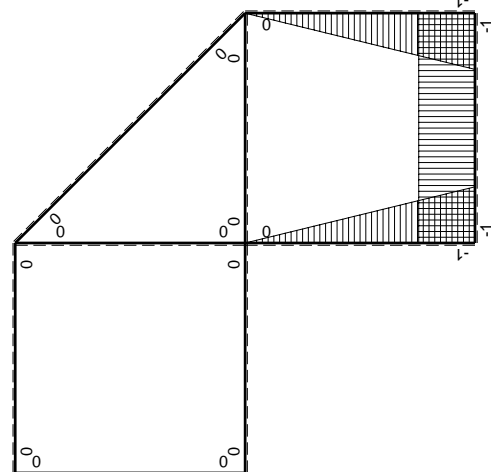

M_x flessione da iperstatica $X=1$

Quadro contribuiti PLV per iperstatica $X=W_{cd}$

\rightarrow	$M_x(x)$	$M_0(x)$	$M_x M_0$	$M_x M_x$	$\int M_x M_0 / E J dx$	$\int X M_x M_x / E J dx$
AB b	0	$-Fx - 1/2qx^2$	0	0	0	0
BA b	0	$3/2Fb - 2Fx + 1/2qx^2$	0	0	0	0
BC b	$-x/b$	$-3/2Fb + 1/2Fx$	$3/2Fx - 1/2Fx^2/b$	x^2/b^2	$7/12Fb^2/EJ$	$1/3Xb/EJ$
CB b	$1-x/b$	$Fb + 1/2Fx$	$Fb - 1/2Fx - 1/2Fx^2/b$	$1 - 2x/b + x^2/b^2$	$1/4Fb^2/EJ$	Xb/EJ
CD b	-1	$-1/2Fx$	$1/2Fx$	1	$1/4Fb^2/EJ$	Xb/EJ
DC b	1	$1/2Fb - 1/2Fx$	$1/2Fb - 1/2Fx$	1	$1/4Fb^2/EJ$	Xb/EJ
DE b	$-1+x/b$	$-1/2Fb - 1/2Fx$	$1/2Fb - 1/2Fx^2/b$	$1 - 2x/b + x^2/b^2$	$1/3Fb^2/EJ$	$1/3Xb/EJ$
ED b	x/b	$Fb - 1/2Fx$	$Fx - 1/2Fx^2/b$	x^2/b^2	$1/3Fb^2/EJ$	$1/3Xb/EJ$
EF $\sqrt{2}b$	0	$3\sqrt{2}/4Fx$	0	0	0	0
FG b	0	$-Fx$	0	0	0	0
GF b	0	$Fb - Fx$	0	0	0	0
GA b	0	0	0	0	0	0
AG b	0	0	0	0	0	0
FB b	0	$3/2Fb - Fx - 1/2qx^2$	0	0	0	0
BF b	0	$-2Fx + 1/2qx^2$	0	0	0	0
BE b	0	0	0	0	0	0
EB b	0	0	0	0	0	0
BE	elongazione asta $N_{1, BE} \epsilon_{BE} L_{BE}$				Fb^2/EJ	
	totali				$13/6Fb^2/EJ$	$5/3Xb/EJ$
	iperstatica $X=W_{cd}$				$-13/10Fb$	

Sviluppi di calcolo iperstatica

$$L_{BC}^{xx} = \int_0^b (x^2/b^2) 1/EJ dx = [1/3 x^3/b^2]_0^b 1/EJ$$

$$= (1/3 b) 1/EJ = 1/3 b/EJ$$

$$L_{CB}^{xx} = \int_0^b (1 - 2x/b + x^2/b^2) 1/EJ dx = [x - x^2/b + 1/3 x^3/b^2]_0^b 1/EJ$$

$$= (b - b + 1/3 b) 1/EJ = 1/3 b/EJ$$

$$L_{CD}^{xx} = \int_0^b (1) 1/EJ dx = [x]_0^b 1/EJ$$

$$= (b) 1/EJ = b/EJ$$

$$L_{DC}^{xx} = \int_0^b (1) 1/EJ dx = [x]_0^b 1/EJ$$

$$= (b) 1/EJ = b/EJ$$

$$L_{DE}^{xx} = \int_0^b (1 - 2x/b + x^2/b^2) 1/EJ dx = [x - x^2/b + 1/3 x^3/b^2]_0^b 1/EJ$$

$$= (b - b + 1/3 b) 1/EJ = 1/3 b/EJ$$

$$L_{ED}^{xx} = \int_0^b (x^2/b^2) 1/EJ dx = [1/3 x^3/b^2]_0^b 1/EJ$$

$$= (1/3 b) 1/EJ = 1/3 b/EJ$$

$$L_{BC}^{xo} = \int_0^b (3/2 x/b - 1/2 x^2/b^2) Fb 1/EJ dx = [3/4 x^2/b - 1/6 x^3/b^2]_0^b Fb 1/EJ$$

$$= (3/4 b - 1/6 b) Fb 1/EJ = 7/12 Fb^2/EJ$$

$$L_{CB}^{xo} = \int_0^b (1 - 1/2 x/b - 1/2 x^2/b^2) Fb 1/EJ dx = [x - 1/4 x^2/b - 1/6 x^3/b^2]_0^b Fb 1/EJ$$

$$= (b - 1/4 b - 1/6 b) Fb 1/EJ = 7/12 Fb^2/EJ$$

$$L_{CD}^{xo} = \int_0^b (1/2 x/b) Fb 1/EJ dx = [1/4 x^2/b]_0^b Fb 1/EJ$$

$$= (1/4 b) Fb 1/EJ = 1/4 Fb^2/EJ$$

$$L_{DC}^{xo} = \int_0^b (1/2 - 1/2 x/b) Fb 1/EJ dx = [1/2 x - 1/4 x^2/b]_0^b Fb 1/EJ$$

$$= (1/2 b - 1/4 b) Fb 1/EJ = 1/4 Fb^2/EJ$$

$$L_{DE}^{xo} = \int_0^b (1/2 - 1/2 x^2/b^2) Fb 1/EJ dx = [1/2 x - 1/6 x^3/b^2]_0^b Fb 1/EJ$$

$$= (1/2 b - 1/6 b) Fb 1/EJ = 1/3 Fb^2/EJ$$

$$L_{ED}^{xo} = \int_0^b (x/b - 1/2 x^2/b^2) Fb 1/EJ dx = [1/2 x^2/b - 1/6 x^3/b^2]_0^b Fb 1/EJ$$

$$= (1/2 b - 1/6 b) Fb 1/EJ = 1/3 Fb^2/EJ$$

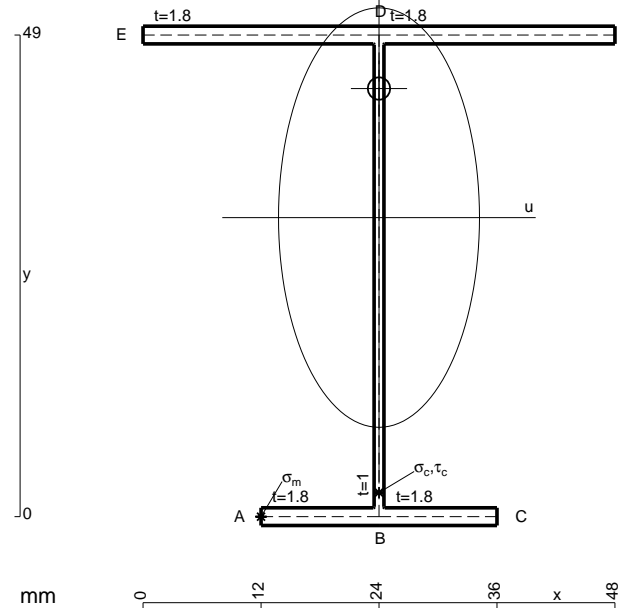

- A = 178.6 mm²
- J_u = 81324. mm⁴
- J_v = 18662. mm⁴
- J_I = 156.3 mm⁴
- y_o = 13.13 mm
- y_g = 30.43 mm
- N = -1280. N
- T_y = -1280. N
- M_x = -614400. Nmm
- x_m = 12. mm
- u_m = -12. mm
- v_m = -30.43 mm
- σ_m = N/A-Mv/J_u = -237. N/mm²
- x_c = 24. mm
- v_c = -30.43 mm
- σ_c = N/A-Mv/J_u = -237. N/mm²
- τ_c = TS_v/tJ_u = 20.69 N/mm²
- τ_g = TS_v/tJ_u = 20.69 N/mm²
- t_c = 640. mm
- σ_o = √σ²+3τ² = 239.7 N/mm²

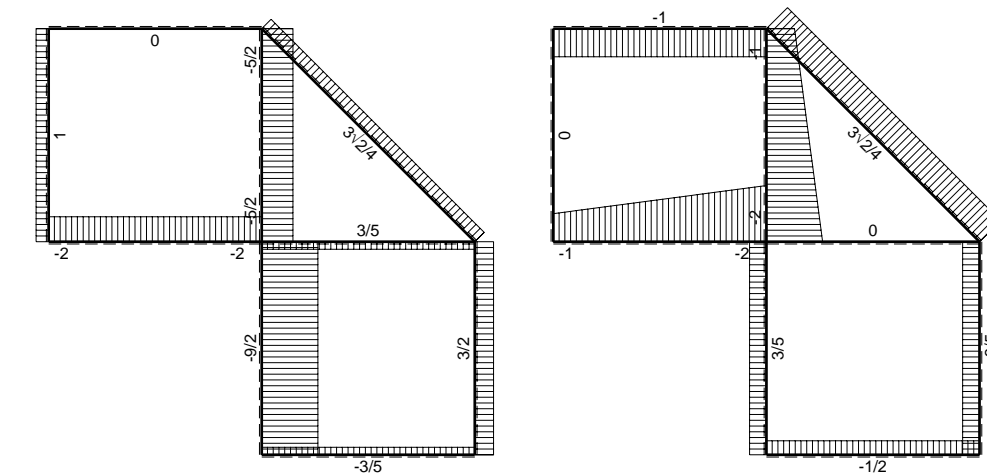
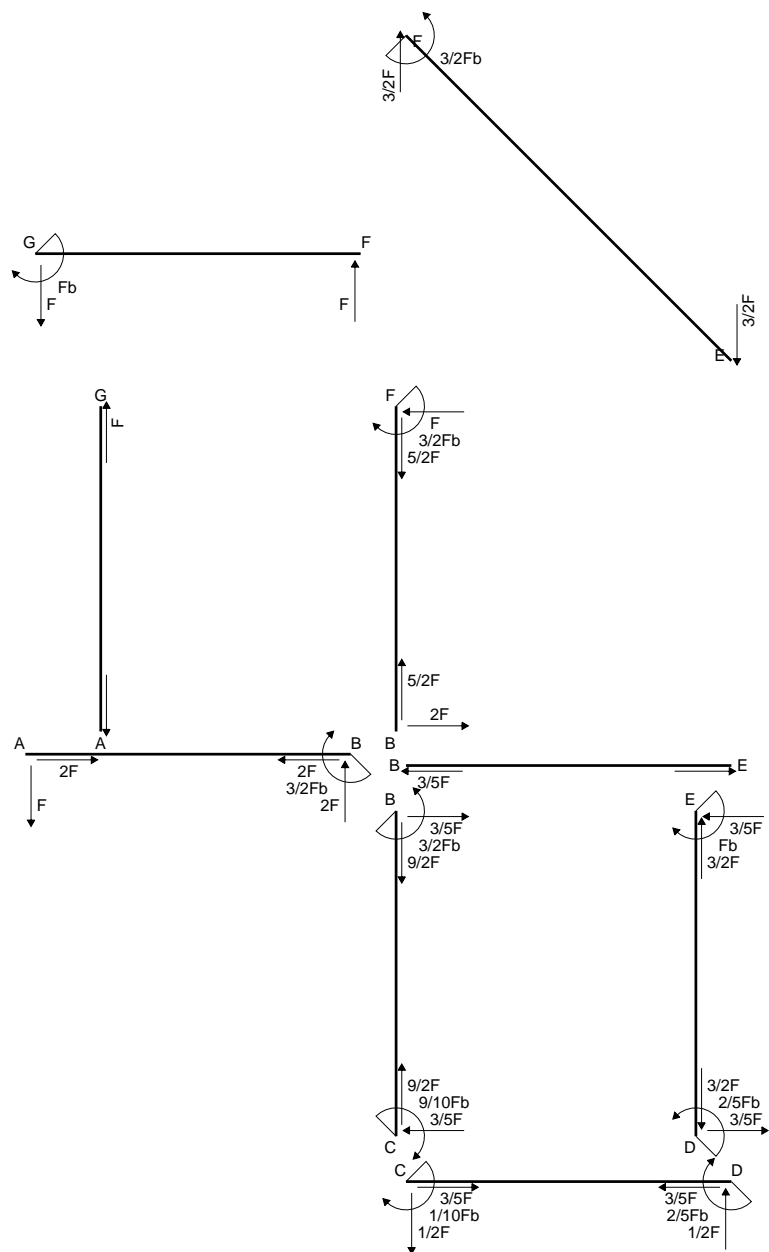

← ⊕ → F

↑ ⊕ ↓ F

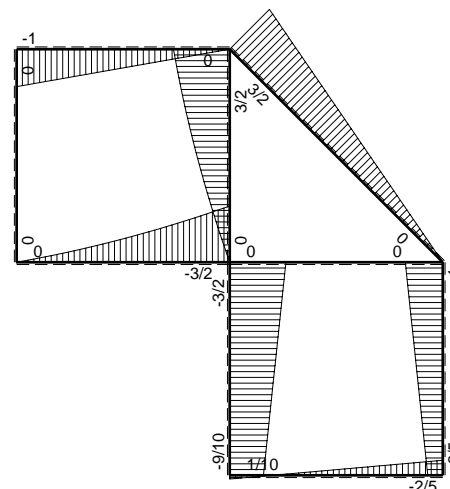

⊕ ⊖ Fb

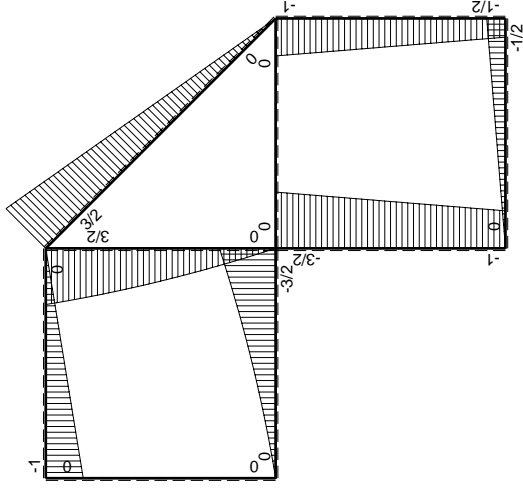
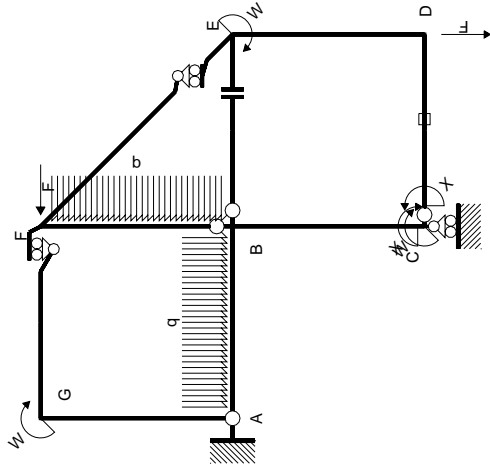

Schema di calcolo iperstatico

M_0 flessione da carichi assegnati

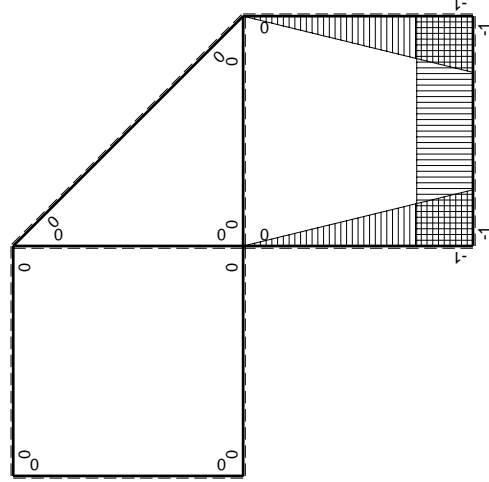

M_x flessione da iperstatica $X=1$

Quadro contribuiti PLV per iperstatica $X=W_{cd}$

\rightarrow	$M_x(x)$	$M_0(x)$	$M_x M_0$	$M_x M_x$	$\int M_x M_0 / EJ dx$	$\int X M_x M_x / EJ dx$
AB b	0	$-Fx - 1/2qx^2$	0	0	0	0
BA b	0	$3/2Fb - 2Fx + 1/2qx^2$	0	0	0	0
BC b	$-x/b$	$-3/2Fb + 1/2Fx$	$3/2Fx - 1/2Fx^2/b$	x^2/b^2	$7/12Fb^2/EJ$	$1/3Xb/EJ$
CB b	$1-x/b$	$Fb + 1/2Fx$	$Fb - 1/2Fx - 1/2Fx^2/b$	$1 - 2x/b + x^2/b^2$		
CD b	-1	$-1/2Fx$	$1/2Fx$	1	$1/4Fb^2/EJ$	Xb/EJ
DC b	1	$1/2Fb - 1/2Fx$	$1/2Fb - 1/2Fx$	1		
DE b	$-1+x/b$	$-1/2Fb - 1/2Fx$	$1/2Fb - 1/2Fx^2/b$	$1 - 2x/b + x^2/b^2$	$1/3Fb^2/EJ$	$1/3Xb/EJ$
ED b	x/b	$Fb - 1/2Fx$	$Fx - 1/2Fx^2/b$	x^2/b^2		
EF $\sqrt{2}b$	0	$3\sqrt{2}/4Fx$	0	0	0	0
FG b	0	$-Fx$	0	0	0	0
GF b	0	$Fb - Fx$	0	0	0	0
GA b	0	0	0	0	0	0
AG b	0	0	0	0	0	0
FB b	0	$3/2Fb - Fx - 1/2qx^2$	0	0	0	0
BF b	0	$-2Fx + 1/2qx^2$	0	0	0	0
BE b	0	0	0	0	0	0
EB b	0	0	0	0	0	0
CD	elongazione asta $N_{1,cd} \epsilon_{cd} L_{cd}$				$-Fb^2/EJ$	
	totali				$1/6Fb^2/EJ$	$5/3Xb/EJ$
	iperstatica $X=W_{cd}$				$-1/10Fb$	

Sviluppi di calcolo iperstatica

$$L_{BC}^{xx} = \int_0^b (x^2/b^2) 1/EJ dx = [1/3 x^3/b^2]_0^b 1/EJ$$

$$= (1/3 b) 1/EJ = 1/3 b/EJ$$

$$L_{CB}^{xx} = \int_0^b (1 - 2x/b + x^2/b^2) 1/EJ dx = [x - x^2/b + 1/3 x^3/b^2]_0^b 1/EJ$$

$$= (b - b + 1/3 b) 1/EJ = 1/3 b/EJ$$

$$L_{CD}^{xx} = \int_0^b (1) 1/EJ dx = [x]_0^b 1/EJ$$

$$= (b) 1/EJ = b/EJ$$

$$L_{DC}^{xx} = \int_0^b (1) 1/EJ dx = [x]_0^b 1/EJ$$

$$= (b) 1/EJ = b/EJ$$

$$L_{DE}^{xx} = \int_0^b (1 - 2x/b + x^2/b^2) 1/EJ dx = [x - x^2/b + 1/3 x^3/b^2]_0^b 1/EJ$$

$$= (b - b + 1/3 b) 1/EJ = 1/3 b/EJ$$

$$L_{ED}^{xx} = \int_0^b (x^2/b^2) 1/EJ dx = [1/3 x^3/b^2]_0^b 1/EJ$$

$$= (1/3 b) 1/EJ = 1/3 b/EJ$$

$$L_{BC}^{xo} = \int_0^b (3/2 x/b - 1/2 x^2/b^2) Fb 1/EJ dx = [3/4 x^2/b - 1/6 x^3/b^2]_0^b Fb 1/EJ$$

$$= (3/4 b - 1/6 b) Fb 1/EJ = 7/12 Fb^2/EJ$$

$$L_{CB}^{xo} = \int_0^b (1 - 1/2 x/b - 1/2 x^2/b^2) Fb 1/EJ dx = [x - 1/4 x^2/b - 1/6 x^3/b^2]_0^b Fb 1/EJ$$

$$= (b - 1/4 b - 1/6 b) Fb 1/EJ = 7/12 Fb^2/EJ$$

$$L_{CD}^{xo} = \int_0^b (1/2 x/b) Fb 1/EJ dx + 1 (-1) 1 Fb^2/EJ = [1/4 x^2/b]_0^b Fb 1/EJ + 1 (-1) 1 Fb^2/EJ$$

$$= (1/4 b) Fb 1/EJ + 1 (-1) 1 Fb^2/EJ = -3/4 Fb^2/EJ$$

$$L_{DC}^{xo} = \int_0^b (1/2 - 1/2 x/b) Fb 1/EJ dx + 1 (-1) 1 Fb^2/EJ = [1/2 x - 1/4 x^2/b]_0^b Fb 1/EJ + 1 (-1) 1 Fb^2/EJ$$

$$= (1/2 b - 1/4 b) Fb 1/EJ + 1 (-1) 1 Fb^2/EJ = -3/4 Fb^2/EJ$$

$$L_{DE}^{xo} = \int_0^b (1/2 - 1/2 x^2/b^2) Fb 1/EJ dx = [1/2 x - 1/6 x^3/b^2]_0^b Fb 1/EJ$$

$$= (1/2 b - 1/6 b) Fb 1/EJ = 1/3 Fb^2/EJ$$

$$L_{ED}^{xo} = \int_0^b (x/b - 1/2 x^2/b^2) Fb 1/EJ dx = [1/2 x^2/b - 1/6 x^3/b^2]_0^b Fb 1/EJ$$

$$= (1/2 b - 1/6 b) Fb 1/EJ = 1/3 Fb^2/EJ$$

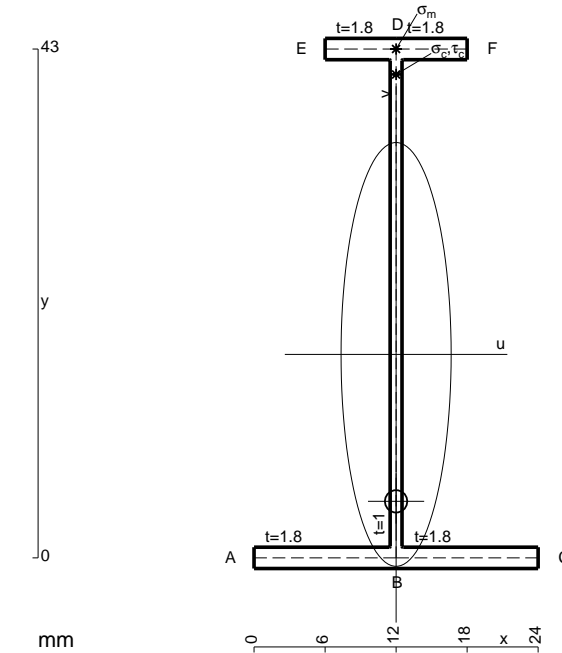

- A = 107.8 mm²
- J_u = 34579. mm⁴
- J_v = 2333. mm⁴
- J_i = 84.32 mm⁴
- y_o = -12.41 mm
- y_g = 17.19 mm
- N = -600. N
- T_y = -600. N
- M_x = -274500. Nmm
- x_m = 12. mm
- y_m = 43. mm
- v_m = 25.81 mm
- σ_m = N/A-Mv/J_u = 199.3 N/mm²
- y_c = 2. mm
- u_c = -12. mm
- v_c = -15.19 mm
- σ_c = N/A-Mv/J_u = 199.3 N/mm²
- τ_c = TS¹/tJ_u = 9.673 N/mm²
- τ_g = TS¹/tJ_u = 9.673 N/mm²
- t_c = 300. mm
- σ_o = √σ²+3τ² = 200. N/mm²

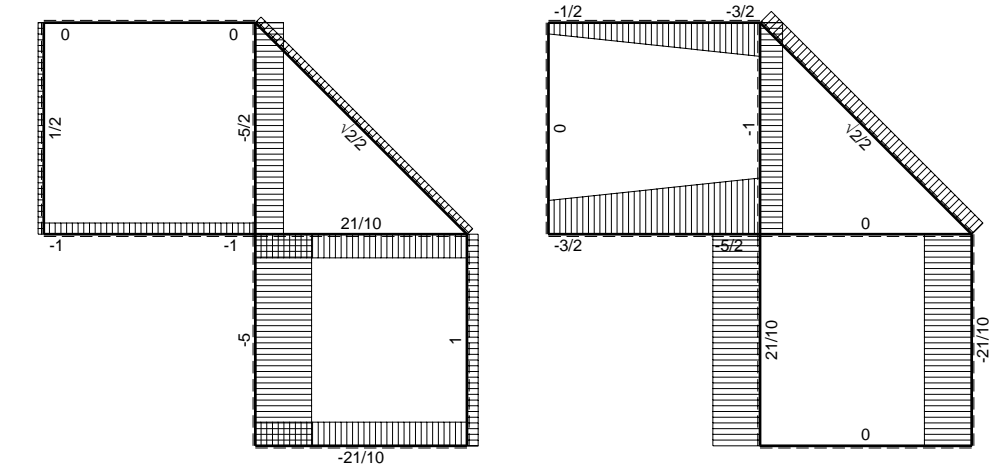
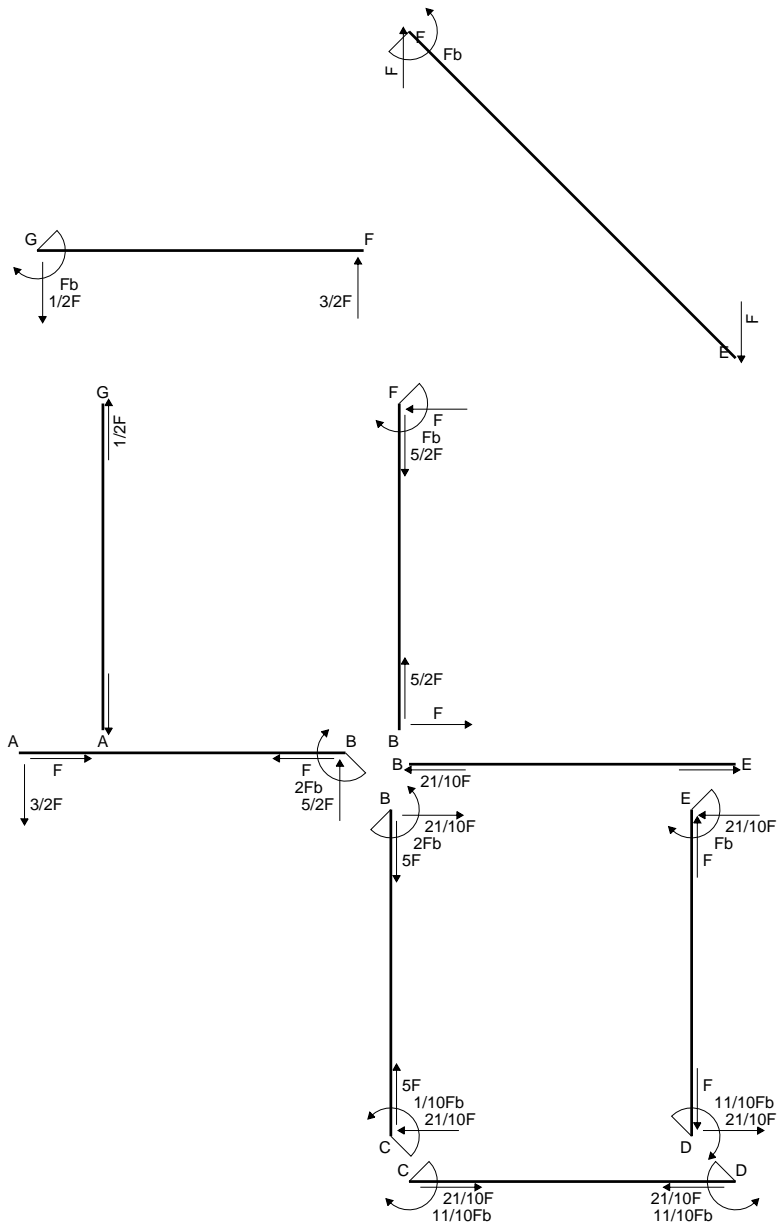

← ⊕ → F

↑ ⊕ ↓ F

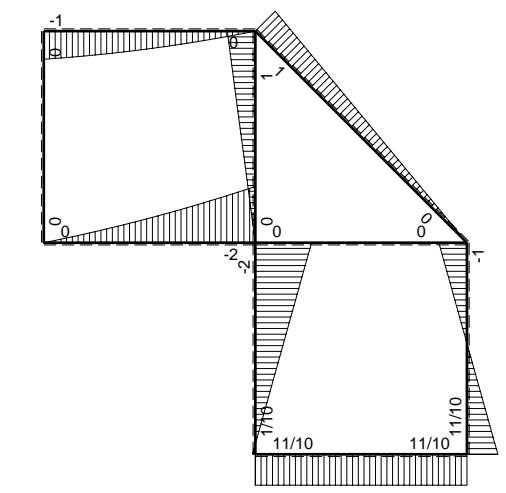

⊕ ⊖ Fb

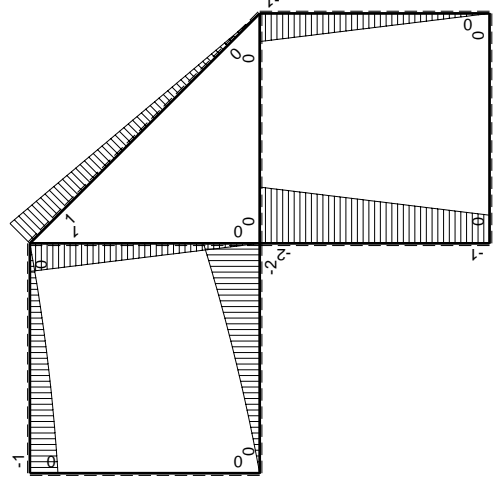
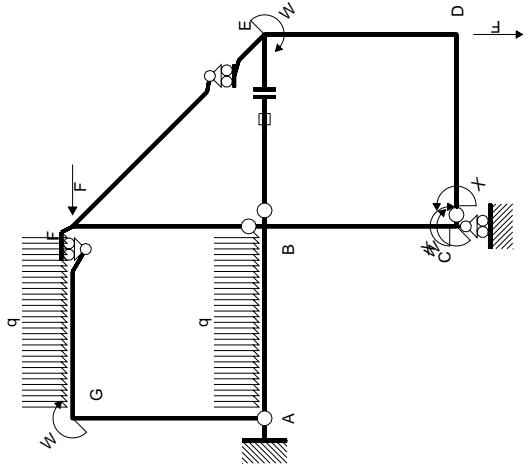

Schema di calcolo iperstatico

M_0 flessione da carichi assegnati

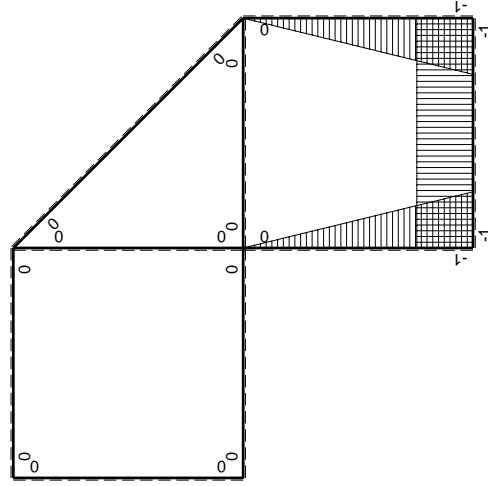

M_x flessione da iperstatica X=1

Quadro contribuiti PLV per iperstatica X=W_{cd}

→	$M_x(x)$	$M_0(x)$	$M_x M_0$	$M_x M_x$	$\int M_x M_0 / EJ dx$	$\int X M_x M_x / EJ dx$
AB b	0	$-3/2Fx - 1/2qx^2$	0	0	0	0
BA b	0	$2Fb - 5/2Fx + 1/2qx^2$	0	0	0	0
BC b	$-x/b$	$-2Fb + Fx$	$2Fx - Fx^2/b$	x^2/b^2	$2/3Fb^2/EJ$	$1/3Xb/EJ$
CB b	$1-x/b$	$Fb + Fx$	$Fb - Fx^2/b$	$1 - 2x/b + x^2/b^2$		
CD b	-1	0	0	1	0	Xb/EJ
DC b	1	0	0	1	0	
DE b	$-1+x/b$	$-Fx$	$Fx - Fx^2/b$	$1 - 2x/b + x^2/b^2$	$1/6Fb^2/EJ$	$1/3Xb/EJ$
ED b	x/b	$Fb - Fx$	$Fx - Fx^2/b$	x^2/b^2		
EF $\sqrt{2}b$	0	$\sqrt{2}/2Fx$	0	0	0	0
FG b	0	$-3/2Fx + 1/2qx^2$	0	0	0	0
GF b	0	$Fb - 1/2Fx - 1/2qx^2$	0	0	0	0
GA b	0	0	0	0	0	0
AG b	0	0	0	0	0	0
FB b	0	$Fb - Fx$	0	0	0	0
BF b	0	$-Fx$	0	0	0	0
BE b	0	0	0	0	0	0
EB b	0	0	0	0	0	0
BE	elongazione asta $N_{1, BE} \epsilon_{BE} L_{BE}$				Fb^2/EJ	
	totali				$11/6Fb^2/EJ$	$5/3Xb/EJ$
	iperstatica X=W _{cd}					$-11/10Fb$

Sviluppi di calcolo iperstatica

$$L_{BC}^{xx} = \int_0^b (x^2/b^2) 1/EJ dx = [1/3 x^3/b^2]_0^b 1/EJ$$

$$= (1/3 b) 1/EJ = 1/3 b/EJ$$

$$L_{CB}^{xx} = \int_0^b (1 - 2x/b + x^2/b^2) 1/EJ dx = [x - x^2/b + 1/3 x^3/b^2]_0^b 1/EJ$$

$$= (b - b + 1/3 b) 1/EJ = 1/3 b/EJ$$

$$L_{CD}^{xx} = \int_0^b (1) 1/EJ dx = [x]_0^b 1/EJ$$

$$= (b) 1/EJ = b/EJ$$

$$L_{DC}^{xx} = \int_0^b (1) 1/EJ dx = [x]_0^b 1/EJ$$

$$= (b) 1/EJ = b/EJ$$

$$L_{DE}^{xx} = \int_0^b (1 - 2x/b + x^2/b^2) 1/EJ dx = [x - x^2/b + 1/3 x^3/b^2]_0^b 1/EJ$$

$$= (b - b + 1/3 b) 1/EJ = 1/3 b/EJ$$

$$L_{ED}^{xx} = \int_0^b (x^2/b^2) 1/EJ dx = [1/3 x^3/b^2]_0^b 1/EJ$$

$$= (1/3 b) 1/EJ = 1/3 b/EJ$$

$$L_{BC}^{x_0} = \int_0^b (2x/b - x^2/b^2) Fb 1/EJ dx = [x^2/b - 1/3 x^3/b^2]_0^b Fb 1/EJ$$

$$= (b - 1/3 b) Fb 1/EJ = 2/3 Fb^2/EJ$$

$$L_{CB}^{x_0} = \int_0^b (1 - x^2/b^2) Fb 1/EJ dx = [x - 1/3 x^3/b^2]_0^b Fb 1/EJ$$

$$= (b - 1/3 b) Fb 1/EJ = 2/3 Fb^2/EJ$$

$$L_{DE}^{x_0} = \int_0^b (x/b - x^2/b^2) Fb 1/EJ dx = [1/2 x^2/b - 1/3 x^3/b^2]_0^b Fb 1/EJ$$

$$= (1/2 b - 1/3 b) Fb 1/EJ = 1/6 Fb^2/EJ$$

$$L_{ED}^{x_0} = \int_0^b (x/b - x^2/b^2) Fb 1/EJ dx = [1/2 x^2/b - 1/3 x^3/b^2]_0^b Fb 1/EJ$$

$$= (1/2 b - 1/3 b) Fb 1/EJ = 1/6 Fb^2/EJ$$

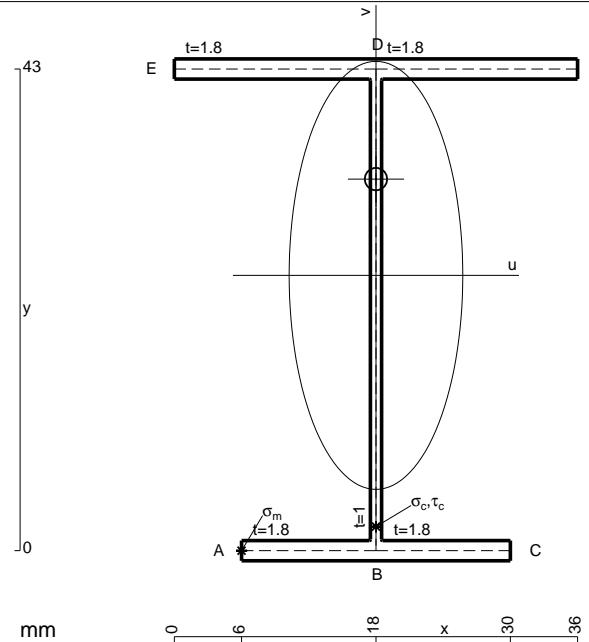

- A = 151. mm²
- J_u = 55120. mm⁴
- J_v = 9072. mm⁴
- J_i = 131. mm⁴
- y_o = 8.596 mm
- y_g = 24.58 mm
- N = -350. N
- T_y = -875. N
- M_x = -455000. Nmm
- x_m = 6. mm
- u_m = -12. mm
- v_m = -24.58 mm
- σ_m = N/A-Mv/J_u = -205.2 N/mm²
- x_c = 18. mm
- v_c = -24.58 mm
- σ_c = N/A-Mv/J_u = -205.2 N/mm²
- τ_c = TS^{*}/tJ_u = 16.85 N/mm²
- τ_g = TS^{*}/tJ_u = 16.85 N/mm²
- t_c = 350. mm
- σ_o = √σ²+3τ² = 207.2 N/mm²

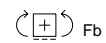
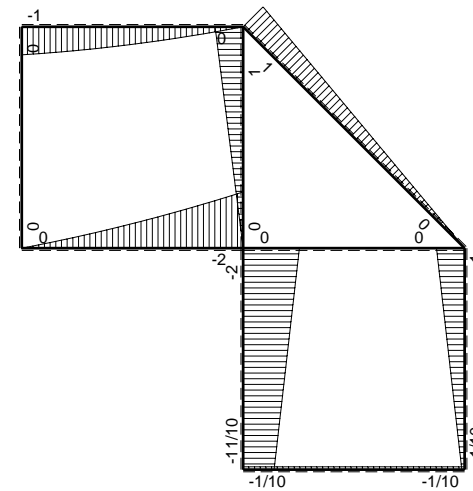
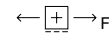
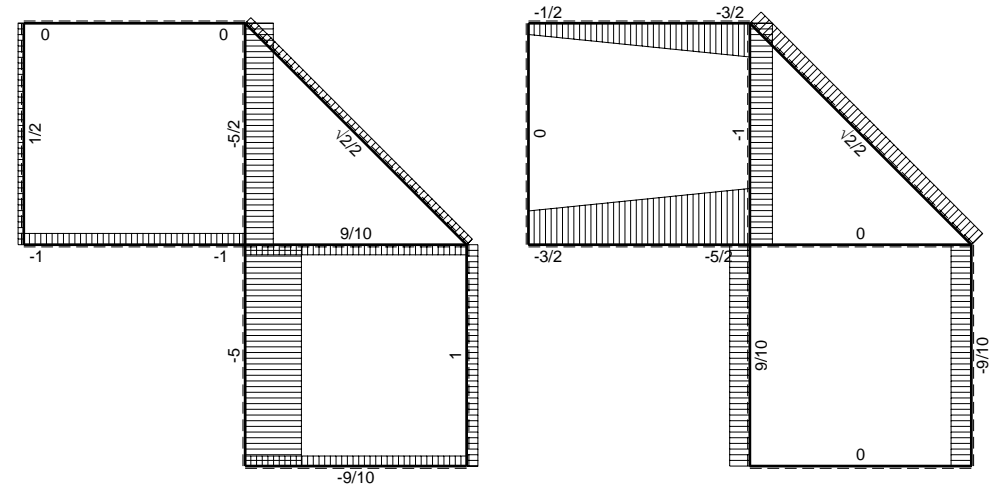
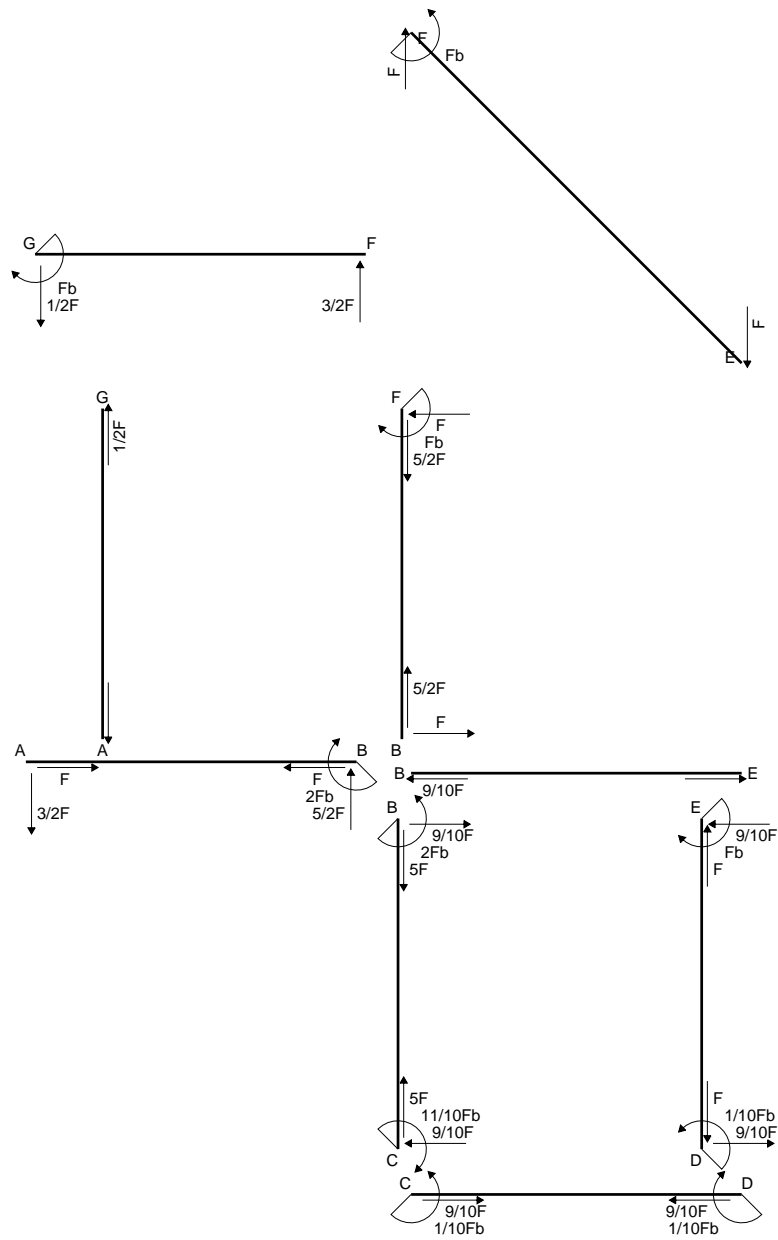

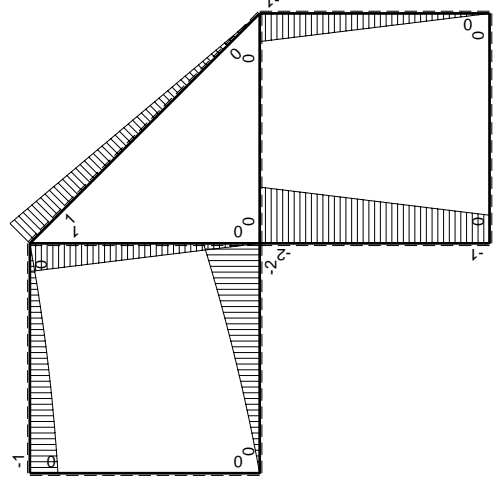
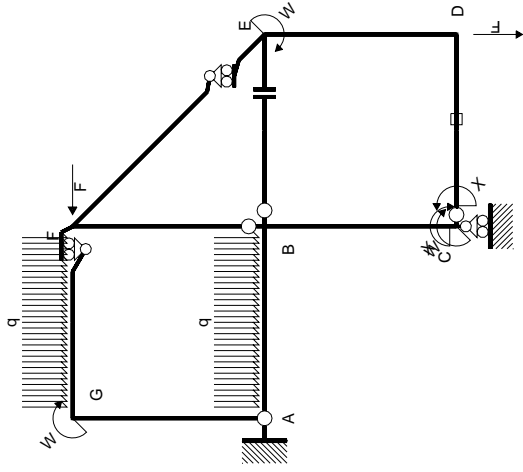

Schema di calcolo iperstatico

M_0 flessione da carichi assegnati

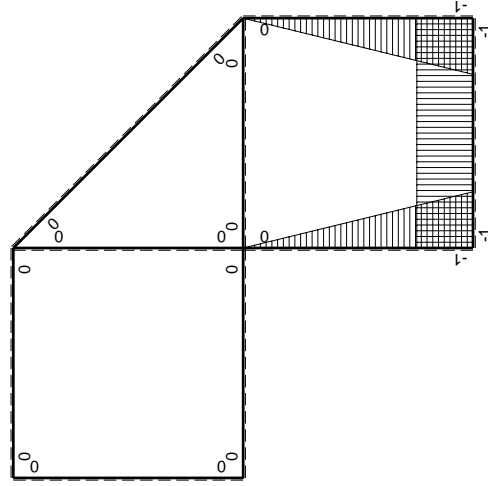

M_x flessione da iperstatica $X=1$

Quadro contribuiti PLV per iperstatica $X=W_{cd}$

\rightarrow	$M_x(x)$	$M_0(x)$	$M_x M_0$	$M_x M_x$	$\int M_x M_0 / EJ dx$	$\int M_x M_x / EJ dx$
AB b	0	$-3/2Fx - 1/2qx^2$	0	0	0	0
BA b	0	$2Fb - 5/2Fx + 1/2qx^2$	0	0	0	0
BC b	$-x/b$	$-2Fb + Fx$	$2Fx - Fx^2/b$	x^2/b^2	$2/3Fb^2/EJ$	$1/3Xb/EJ$
CB b	$1-x/b$	$Fb + Fx$	$Fb - Fx^2/b$	$1 - 2x/b + x^2/b^2$		
CD b	-1	0	0	1	0	Xb/EJ
DC b	1	0	0	1	0	
DE b	$-1+x/b$	$-Fx$	$Fx - Fx^2/b$	$1 - 2x/b + x^2/b^2$	$1/6Fb^2/EJ$	$1/3Xb/EJ$
ED b	x/b	$Fb - Fx$	$Fx - Fx^2/b$	x^2/b^2		
EF $\sqrt{2}b$	0	$\sqrt{2}/2Fx$	0	0	0	0
FG b	0	$-3/2Fx + 1/2qx^2$	0	0	0	0
GF b	0	$Fb - 1/2Fx - 1/2qx^2$	0	0	0	0
GA b	0	0	0	0	0	0
AG b	0	0	0	0	0	0
FB b	0	$Fb - Fx$	0	0	0	0
BF b	0	$-Fx$	0	0	0	0
BE b	0	0	0	0	0	0
EB b	0	0	0	0	0	0
CD	elongazione asta $N_{1,cd} \epsilon_{cd} L_{cd}$				$-Fb^2/EJ$	
	totali				$-1/6Fb^2/EJ$	$5/3Xb/EJ$
	iperstatica $X=W_{cd}$				$1/10Fb$	

Sviluppi di calcolo iperstatica

$$L_{BC}^{xx} = \int_0^b (x^2/b^2) 1/EJ dx = [1/3 x^3/b^2]_0^b 1/EJ$$

$$= (1/3 b) 1/EJ = 1/3 b/EJ$$

$$L_{CB}^{xx} = \int_0^b (1 - 2x/b + x^2/b^2) 1/EJ dx = [x - x^2/b + 1/3 x^3/b^2]_0^b 1/EJ$$

$$= (b - b + 1/3 b) 1/EJ = 1/3 b/EJ$$

$$L_{CD}^{xx} = \int_0^b (1) 1/EJ dx = [x]_0^b 1/EJ$$

$$= (b) 1/EJ = b/EJ$$

$$L_{DC}^{xx} = \int_0^b (1) 1/EJ dx = [x]_0^b 1/EJ$$

$$= (b) 1/EJ = b/EJ$$

$$L_{DE}^{xx} = \int_0^b (1 - 2x/b + x^2/b^2) 1/EJ dx = [x - x^2/b + 1/3 x^3/b^2]_0^b 1/EJ$$

$$= (b - b + 1/3 b) 1/EJ = 1/3 b/EJ$$

$$L_{ED}^{xx} = \int_0^b (x^2/b^2) 1/EJ dx = [1/3 x^3/b^2]_0^b 1/EJ$$

$$= (1/3 b) 1/EJ = 1/3 b/EJ$$

$$L_{BC}^{xo} = \int_0^b (2x/b - x^2/b^2) Fb 1/EJ dx = [x^2/b - 1/3 x^3/b^2]_0^b Fb 1/EJ$$

$$= (b - 1/3 b) Fb 1/EJ = 2/3 Fb^2/EJ$$

$$L_{CB}^{xo} = \int_0^b (1 - x^2/b^2) Fb 1/EJ dx = [x - 1/3 x^3/b^2]_0^b Fb 1/EJ$$

$$= (b - 1/3 b) Fb 1/EJ = 2/3 Fb^2/EJ$$

$$L_{DE}^{xo} = \int_0^b (x/b - x^2/b^2) Fb 1/EJ dx = [1/2 x^2/b - 1/3 x^3/b^2]_0^b Fb 1/EJ$$

$$= (1/2 b - 1/3 b) Fb 1/EJ = 1/6 Fb^2/EJ$$

$$L_{ED}^{xo} = \int_0^b (x/b - x^2/b^2) Fb 1/EJ dx = [1/2 x^2/b - 1/3 x^3/b^2]_0^b Fb 1/EJ$$

$$= (1/2 b - 1/3 b) Fb 1/EJ = 1/6 Fb^2/EJ$$

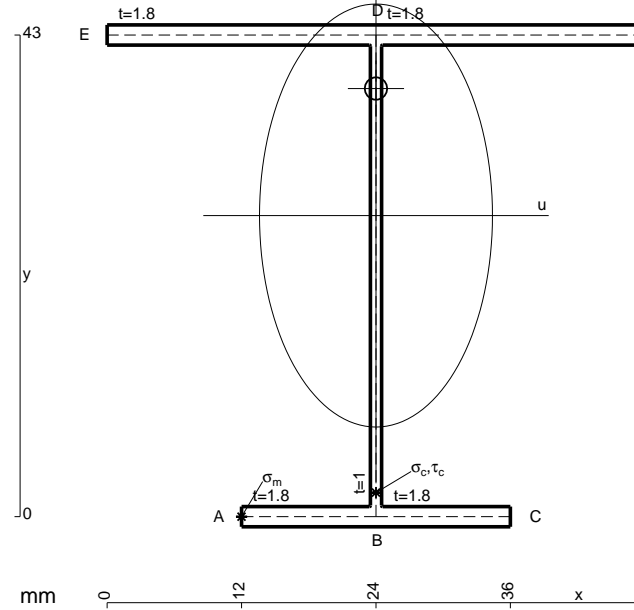

- A = 172.6 mm²
- J_u = 61535. mm⁴
- J_v = 18662. mm⁴
- J_I = 154.3 mm⁴
- y_o = 11.34 mm
- y_g = 26.88 mm
- N = -360. N
- T_y = -900. N
- M_x = -496800. Nmm
- x_m = 12. mm
- u_m = -12. mm
- v_m = -26.88 mm
- σ_m = N/A-Mv/J_u = -219.1 N/mm²
- x_c = 24. mm
- v_c = -26.88 mm
- σ_c = N/A-Mv/J_u = -219.1 N/mm²
- τ_c = TS⁺/tJ_u = 16.98 N/mm²
- τ_g = TS⁺/tJ_u = 16.98 N/mm²
- t_c = 360. mm
- σ_o = √σ²+3τ² = 221.1 N/mm²

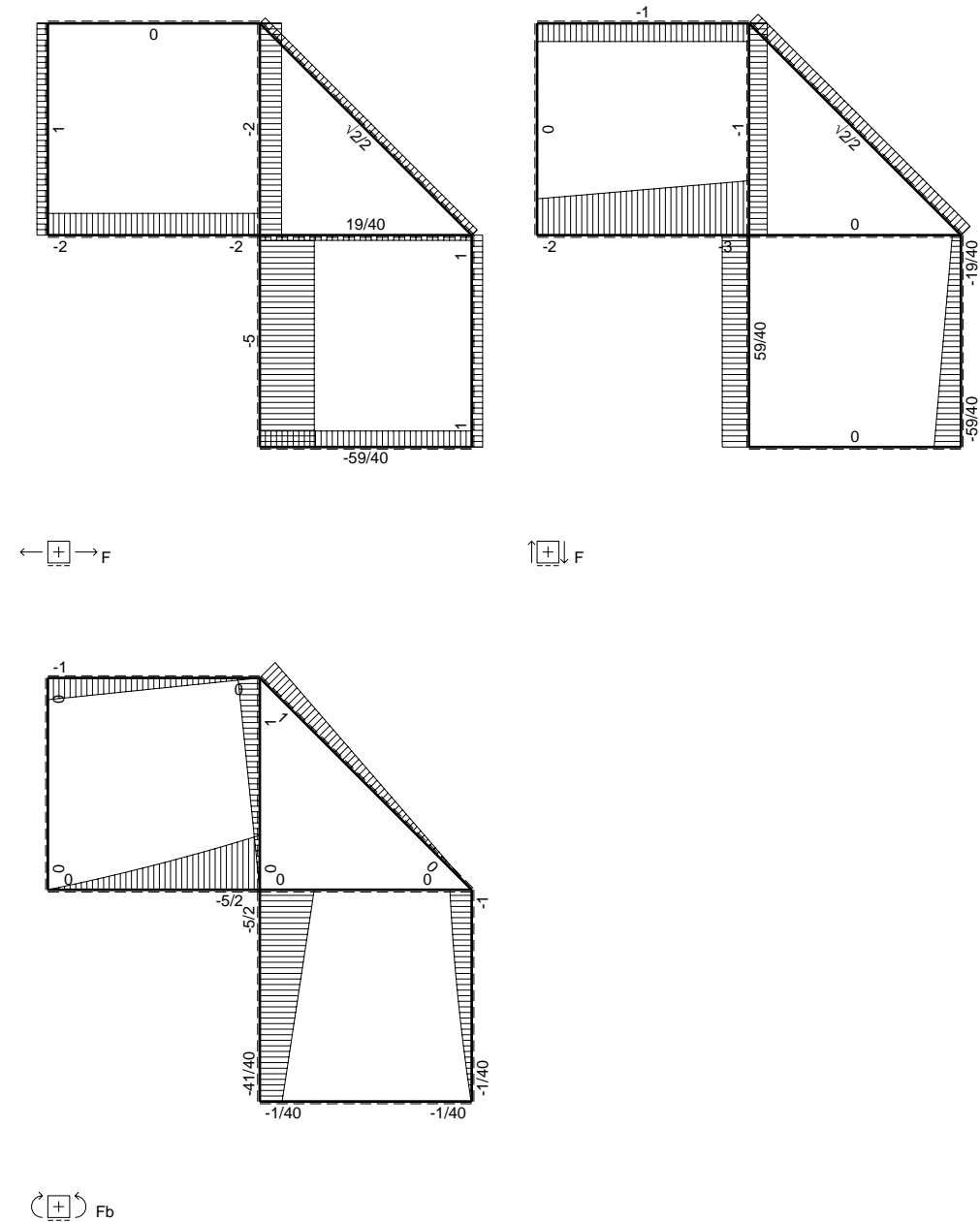
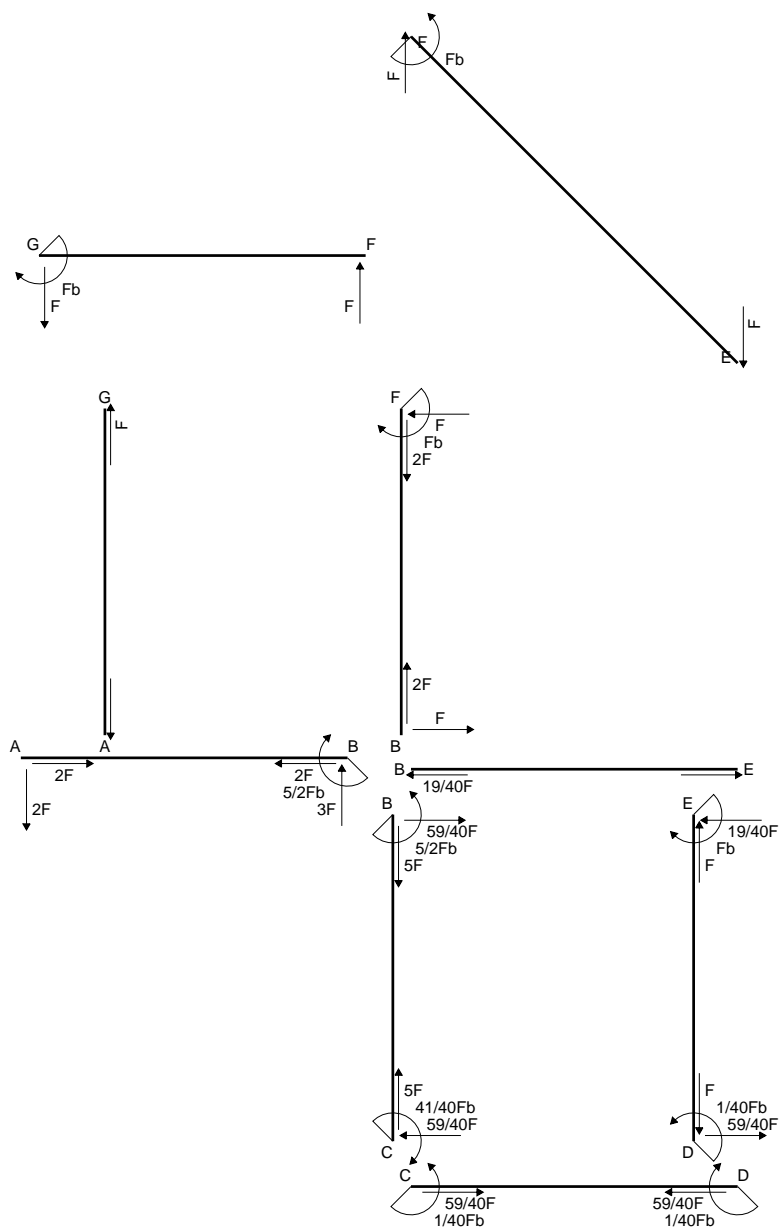

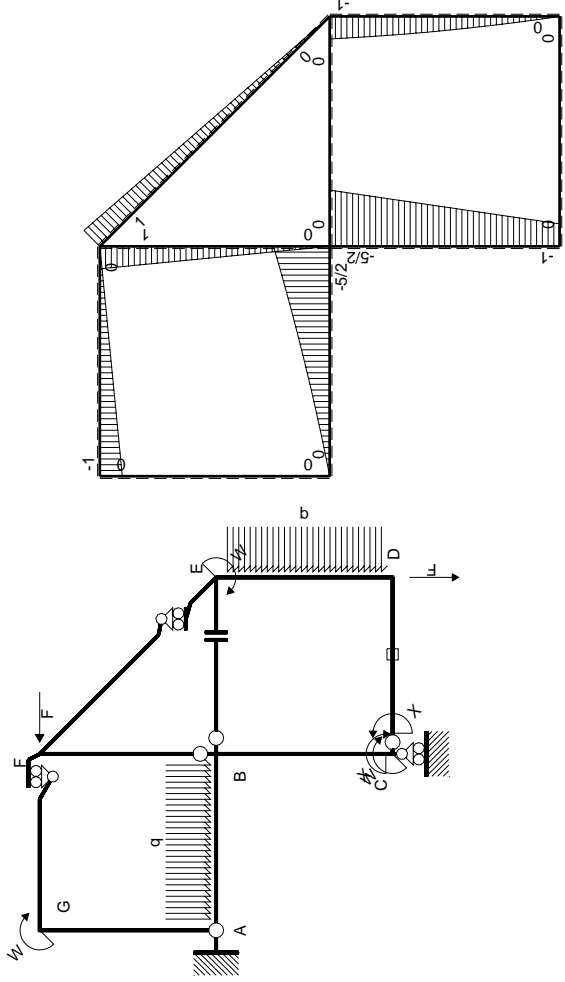

Schema di calcolo iperstatico

M_0 flessione da carichi assegnati

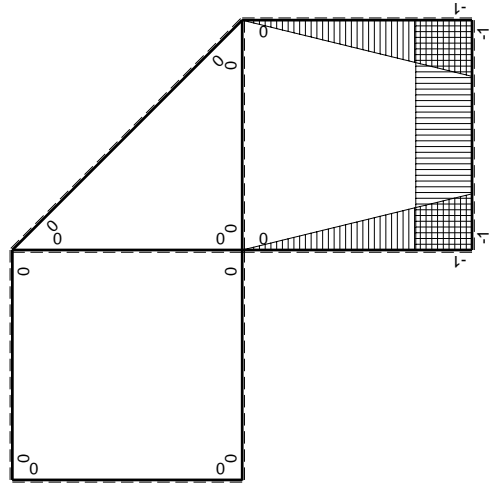

M_x flessione da iperstatica $X=1$

Quadro contributi PLV per iperstatica $X=W_{cd}$

\rightarrow	$M_x(x)$	$M_0(x)$	$M_x M_0$	$M_x M_x$	$\int M_x M_0 / EJ dx$	$\int X M_x M_x / EJ dx$
AB b	0	$-2Fx - 1/2qx^2$	0	0	0	0
BA b	0	$5/2Fb - 3Fx + 1/2qx^2$	0	0	0	0
BC b	$-x/b$	$-5/2Fb + 3/2Fx$	$5/2Fx - 3/2Fx^2/b$	x^2/b^2	$3/4Fb^2/EJ$	$1/3Xb/EJ$
CB b	$1-x/b$	$Fb + 3/2Fx$	$Fb + 1/2Fx - 3/2Fx^2/b$	$1 - 2x/b + x^2/b^2$	0	Xb/EJ
CD b	-1	0	0	1	0	0
DC b	1	0	0	1	0	0
DE b	$-1+x/b$	$-3/2Fx + 1/2qx^2$	$3/2Fx - 2Fx^2/b + 1/2qx^3/b$	$1 - 2x/b + x^2/b^2$	$5/24Fb^2/EJ$	$1/3Xb/EJ$
ED b	x/b	$Fb - 1/2Fx - 1/2qx^2$	$Fx - 1/2Fx^2/b - 1/2qx^3/b$	x^2/b^2	0	0
EF $\sqrt{2}b$	0	$\sqrt{2}/2Fx$	0	0	0	0
FG b	0	-Fx	0	0	0	0
GF b	0	$Fb - Fx$	0	0	0	0
GA b	0	0	0	0	0	0
AG b	0	0	0	0	0	0
FB b	0	$Fb - Fx$	0	0	0	0
BF b	0	-Fx	0	0	0	0
BE b	0	0	0	0	0	0
EB b	0	0	0	0	0	0
CD	elongazione asta $N_{1,cd} \epsilon_{cd} L_{cd}$					
	totali					
	iperstatica $X=W_{cd}$					
					$-Fb^2/EJ$	$5/3Xb/EJ$
					$-1/24Fb^2/EJ$	$1/40Fb$

Sviluppi di calcolo iperstatica

$$L_{BC}^{xx} = \int_0^b (x^2/b^2) 1/EJ dx = [1/3 x^3/b^2]_0^b 1/EJ$$

$$= (1/3 b) 1/EJ = 1/3 b/EJ$$

$$L_{CB}^{xx} = \int_0^b (1 - 2x/b + x^2/b^2) 1/EJ dx = [x - x^2/b + 1/3 x^3/b^2]_0^b 1/EJ$$

$$= (b - b + 1/3 b) 1/EJ = 1/3 b/EJ$$

$$L_{CD}^{xx} = \int_0^b (1) 1/EJ dx = [x]_0^b 1/EJ$$

$$= (b) 1/EJ = b/EJ$$

$$L_{DC}^{xx} = \int_0^b (1) 1/EJ dx = [x]_0^b 1/EJ$$

$$= (b) 1/EJ = b/EJ$$

$$L_{DE}^{xx} = \int_0^b (1 - 2x/b + x^2/b^2) 1/EJ dx = [x - x^2/b + 1/3 x^3/b^2]_0^b 1/EJ$$

$$= (b - b + 1/3 b) 1/EJ = 1/3 b/EJ$$

$$L_{ED}^{xx} = \int_0^b (x^2/b^2) 1/EJ dx = [1/3 x^3/b^2]_0^b 1/EJ$$

$$= (1/3 b) 1/EJ = 1/3 b/EJ$$

$$L_{BC}^{x_0} = \int_0^b (5/2 x/b - 3/2 x^2/b^2) Fb 1/EJ dx = [5/4 x^2/b - 1/2 x^3/b^2]_0^b Fb 1/EJ$$

$$= (5/4 b - 1/2 b) Fb 1/EJ = 3/4 Fb^2/EJ$$

$$L_{CB}^{x_0} = \int_0^b (1 + 1/2 x/b - 3/2 x^2/b^2) Fb 1/EJ dx = [x + 1/4 x^2/b - 1/2 x^3/b^2]_0^b Fb 1/EJ$$

$$= (b + 1/4 b - 1/2 b) Fb 1/EJ = 3/4 Fb^2/EJ$$

$$L_{DE}^{x_0} = \int_0^b (3/2 x/b - 2 x^2/b^2 + 1/2 x^3/b^3) Fb 1/EJ dx = [3/4 x^2/b - 2/3 x^3/b^2 + 1/8 x^4/b^3]_0^b Fb 1/EJ$$

$$= (3/4 b - 2/3 b + 1/8 b) Fb 1/EJ = 5/24 Fb^2/EJ$$

$$L_{ED}^{x_0} = \int_0^b (x/b - 1/2 x^2/b^2 - 1/2 x^3/b^3) Fb 1/EJ dx = [1/2 x^2/b - 1/6 x^3/b^2 - 1/8 x^4/b^3]_0^b Fb 1/EJ$$

$$= (1/2 b - 1/6 b - 1/8 b) Fb 1/EJ = 5/24 Fb^2/EJ$$

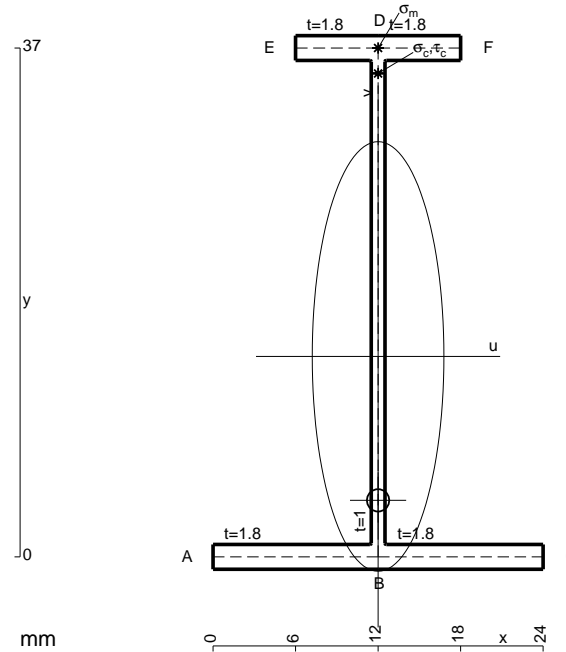

- A = 101.8 mm²
- J_u = 24830. mm⁴
- J_v = 2333. mm⁴
- J_t = 82.32 mm⁴
- y_o = -10.46 mm
- y_g = 14.57 mm
- N = -320. N
- T_y = -480. N
- M_x = -252000. Nmm
- x_m = 12. mm
- y_m = 37. mm
- v_m = 22.43 mm
- σ_m = N/A-Mv/J_u = 224.4 N/mm²
- y_c = 2. mm
- u_c = -12. mm
- v_c = -12.57 mm
- σ_c = N/A-Mv/J_u = 224.4 N/mm²
- τ_c = TS/tJ_u = 9.364 N/mm²
- τ_g = TS/tJ_u = 9.364 N/mm²
- t_c = 160. mm
- σ_o = √σ²+3τ² = 225. N/mm²

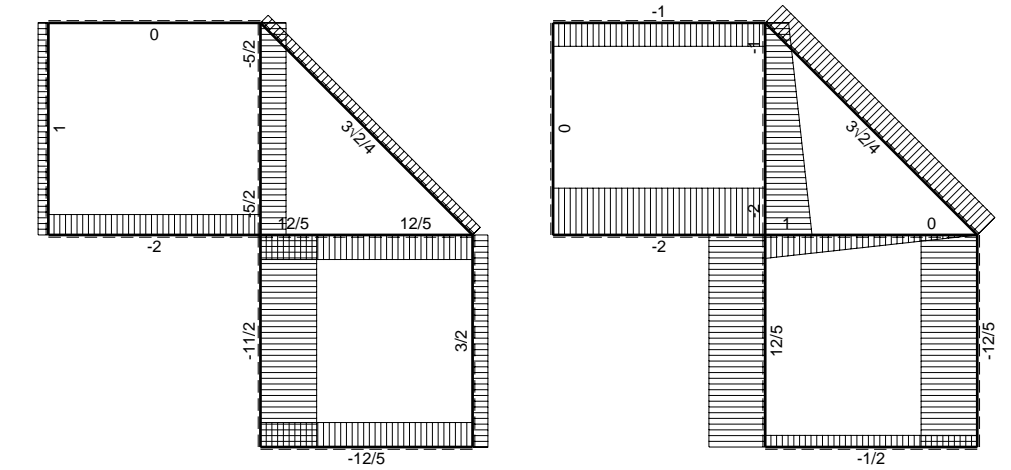
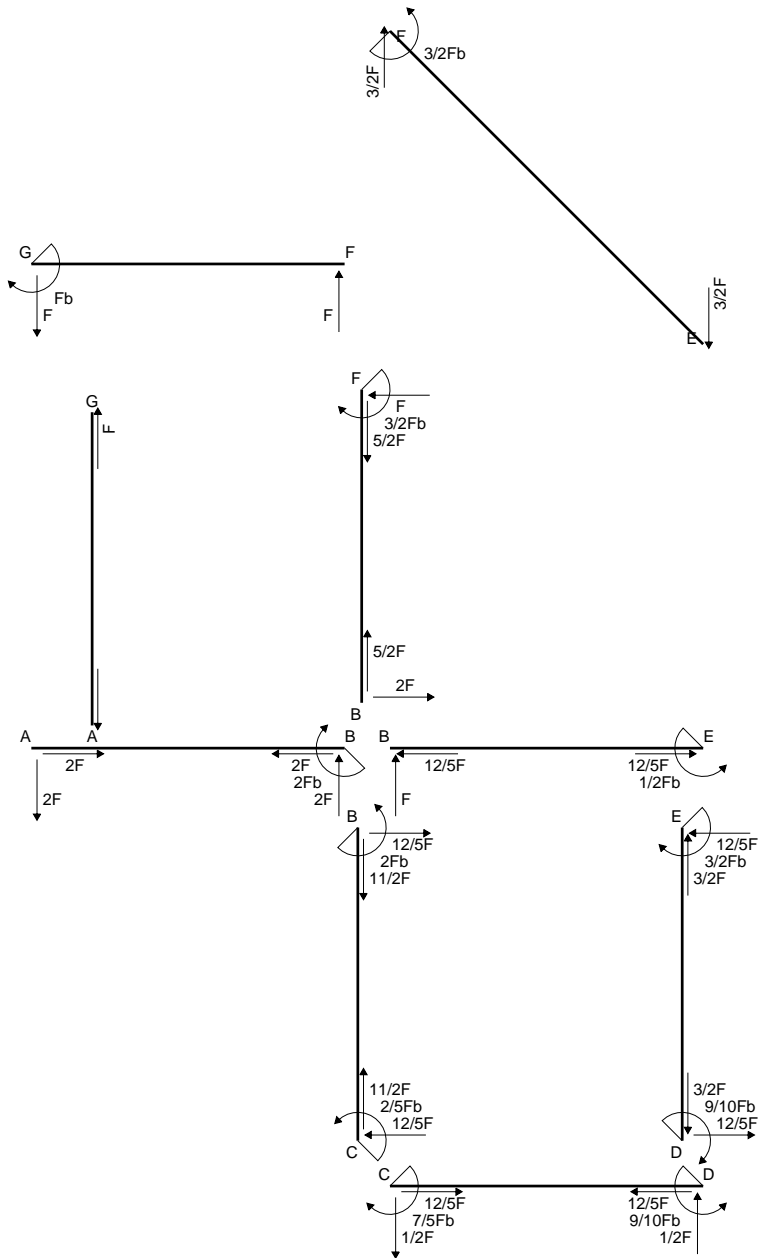

← ⊕ → F

↑ ⊕ ↓ F

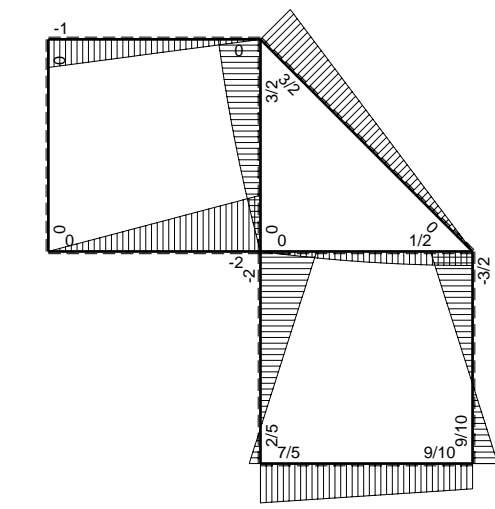

⊕ Fb

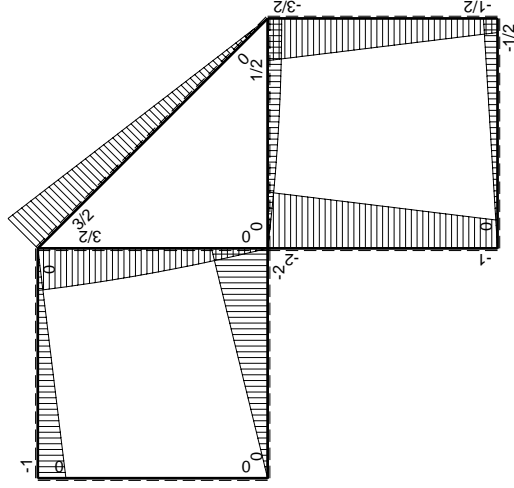
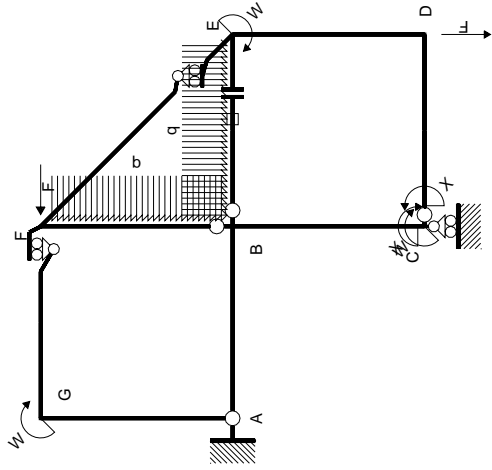

Schema di calcolo iperstatico

(\oplus) M_0 flessione da carichi assegnati

(\oplus) M_x flessione da iperstatica $X=1$

Quadro contribuiti PLV per iperstatica $X=W_{cd}$

\rightarrow	$M_x(x)$	$M_0(x)$	$M_x M_0$	$M_x M_x$	$\int M_x M_0 / EJ dx$	$\int X M_x M_x / EJ dx$
AB b	0	-2Fx	0	0	0	0
BA b	0	2Fb-2Fx	0	0	0	0
BC b	-x/b	-2Fb+Fx	$2Fx-Fx^2/b$	x^2/b^2	$2/3Fb^2/EJ$	$1/3Xb/EJ$
CB b	1-x/b	Fb+Fx	$Fb-Fx^2/b$	$1-2x/b+x^2/b^2$	$1/4Fb^2/EJ$	Xb/EJ
CD b	-1	-1/2Fx	$1/2Fx$	1	$1/4Fb^2/EJ$	Xb/EJ
DC b	1	1/2Fb-1/2Fx	$1/2Fb-1/2Fx$	1	$1/4Fb^2/EJ$	Xb/EJ
DE b	-1+x/b	-1/2Fb-Fx	$1/2Fb+1/2Fx-Fx^2/b$	$1-2x/b+x^2/b^2$	$5/12Fb^2/EJ$	$1/3Xb/EJ$
ED b	x/b	3/2Fb-Fx	$3/2Fx-Fx^2/b$	x^2/b^2	$5/12Fb^2/EJ$	$1/3Xb/EJ$
EF $\sqrt{2}b$	0	$3\sqrt{2}/4Fx$	0	0	0	0
FG b	0	-Fx	0	0	0	0
GF b	0	Fb-Fx	0	0	0	0
GA b	0	0	0	0	0	0
AG b	0	0	0	0	0	0
FB b	0	$3/2Fb-Fx-1/2qx^2$	0	0	0	0
BF b	0	$-2Fx+1/2qx^2$	0	0	0	0
BE b	0	$Fx-1/2qx^2$	0	0	0	0
EB b	0	$-1/2Fb+1/2qx^2$	0	0	0	0
BE	elongazione asta $N_{1, BE}^E - N_{BE}^E - N_{BE}^E$				Fb^2/EJ	$5/3Xb/EJ$
	totali				$7/3Fb^2/EJ$	$5/3Xb/EJ$
	iperstatica $X=W_{cd}$				$-7/5Fb$	

Sviluppi di calcolo iperstatica

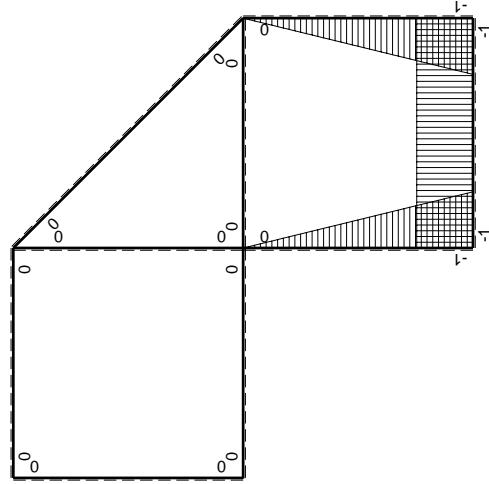

$$L_{BC}^{xx} = \int_0^b (x^2/b^2) 1/EJ dx = [1/3 x^3/b^2]_0^b 1/EJ$$

$$= (1/3 b) 1/EJ = 1/3 b/EJ$$

$$L_{CB}^{xx} = \int_0^b (1 - 2x/b + x^2/b^2) 1/EJ dx = [x - x^2/b + 1/3 x^3/b^2]_0^b 1/EJ$$

$$= (b - b + 1/3 b) 1/EJ = 1/3 b/EJ$$

$$L_{CD}^{xx} = \int_0^b (1) 1/EJ dx = [x]_0^b 1/EJ$$

$$= (b) 1/EJ = b/EJ$$

$$L_{DC}^{xx} = \int_0^b (1) 1/EJ dx = [x]_0^b 1/EJ$$

$$= (b) 1/EJ = b/EJ$$

$$L_{DE}^{xx} = \int_0^b (1 - 2x/b + x^2/b^2) 1/EJ dx = [x - x^2/b + 1/3 x^3/b^2]_0^b 1/EJ$$

$$= (b - b + 1/3 b) 1/EJ = 1/3 b/EJ$$

$$L_{ED}^{xx} = \int_0^b (x^2/b^2) 1/EJ dx = [1/3 x^3/b^2]_0^b 1/EJ$$

$$= (1/3 b) 1/EJ = 1/3 b/EJ$$

$$L_{BC}^{xo} = \int_0^b (2x/b - x^2/b^2) Fb 1/EJ dx = [x^2/b - 1/3 x^3/b^2]_0^b Fb 1/EJ$$

$$= (b - 1/3 b) Fb 1/EJ = 2/3 Fb^2/EJ$$

$$L_{CB}^{xo} = \int_0^b (1 - x^2/b^2) Fb 1/EJ dx = [x - 1/3 x^3/b^2]_0^b Fb 1/EJ$$

$$= (b - 1/3 b) Fb 1/EJ = 2/3 Fb^2/EJ$$

$$L_{CD}^{xo} = \int_0^b (1/2 x/b) Fb 1/EJ dx = [1/4 x^2/b]_0^b Fb 1/EJ$$

$$= (1/4 b) Fb 1/EJ = 1/4 Fb^2/EJ$$

$$L_{DC}^{xo} = \int_0^b (1/2 - 1/2 x/b) Fb 1/EJ dx = [1/2 x - 1/4 x^2/b]_0^b Fb 1/EJ$$

$$= (1/2 b - 1/4 b) Fb 1/EJ = 1/4 Fb^2/EJ$$

$$L_{DE}^{xo} = \int_0^b (1/2 + 1/2 x/b - x^2/b^2) Fb 1/EJ dx = [1/2 x + 1/4 x^2/b - 1/3 x^3/b^2]_0^b Fb 1/EJ$$

$$= (1/2 b + 1/4 b - 1/3 b) Fb 1/EJ = 5/12 Fb^2/EJ$$

$$L_{ED}^{xo} = \int_0^b (3/2 x/b - x^2/b^2) Fb 1/EJ dx = [3/4 x^2/b - 1/3 x^3/b^2]_0^b Fb 1/EJ$$

$$= (3/4 b - 1/3 b) Fb 1/EJ = 5/12 Fb^2/EJ$$

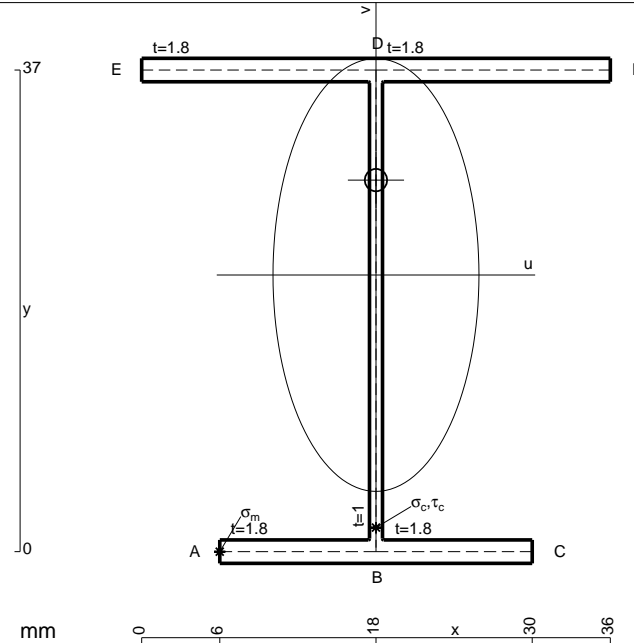

- A = 145. mm²
- J_u = 40083. mm⁴
- J_v = 9072. mm⁴
- J_i = 129. mm⁴
- y_o = 7.287 mm
- y_g = 21.26 mm
- N = -660. N
- T_y = -660. N
- M_x = -435600. Nmm
- x_m = 6. mm
- u_m = -12. mm
- v_m = -21.26 mm
- σ_m = N/A-Mv/J_u = -235.6 N/mm²
- x_c = 18. mm
- v_c = -21.26 mm
- σ_c = N/A-Mv/J_u = -235.6 N/mm²
- τ_c = TS²/tJ_u = 15.12 N/mm²
- τ_g = TS²/tJ_u = 15.12 N/mm²
- t_c = 330. mm
- σ_o = √σ²+3τ² = 237. N/mm²

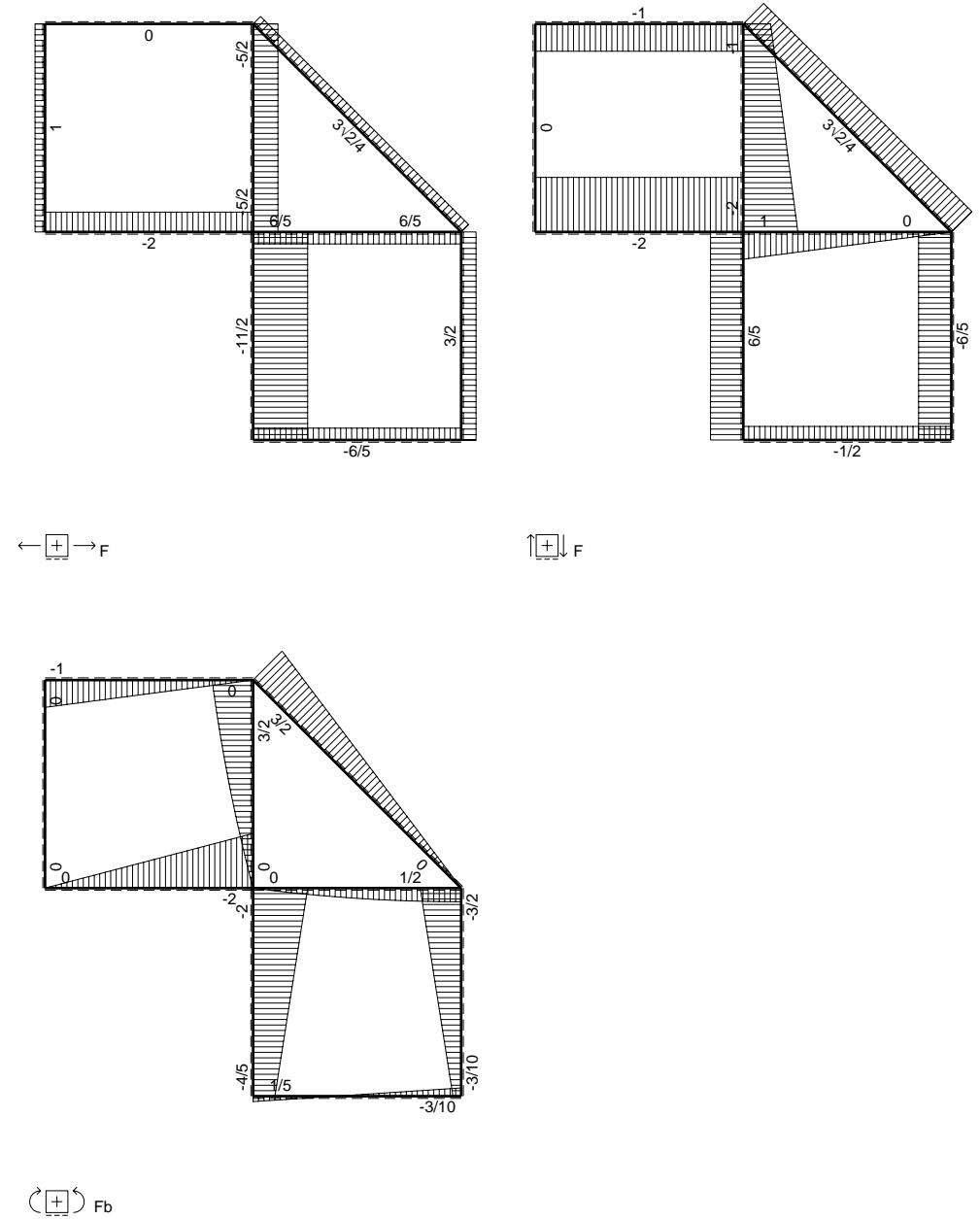
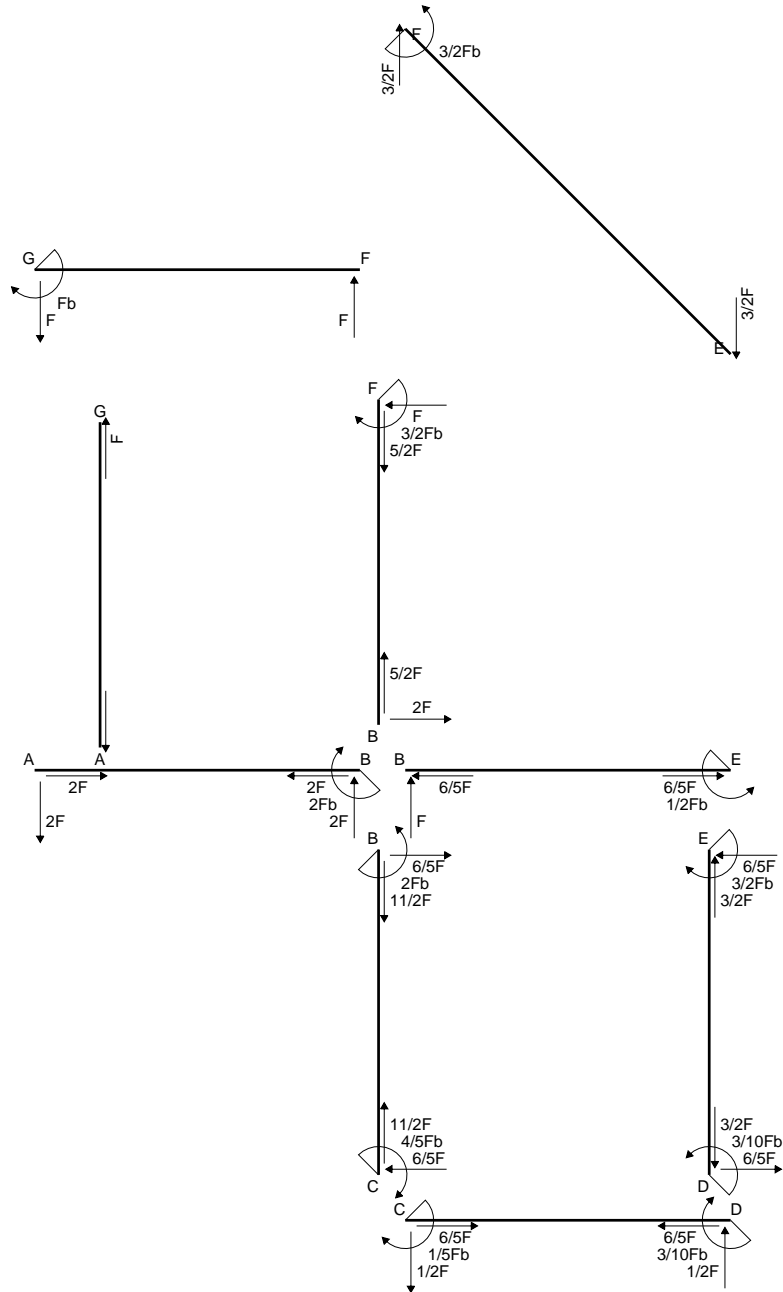

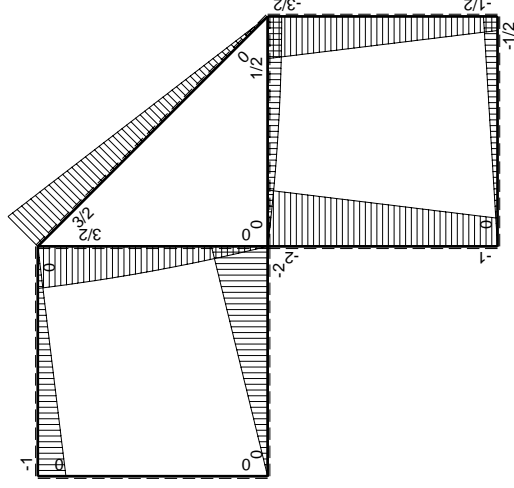
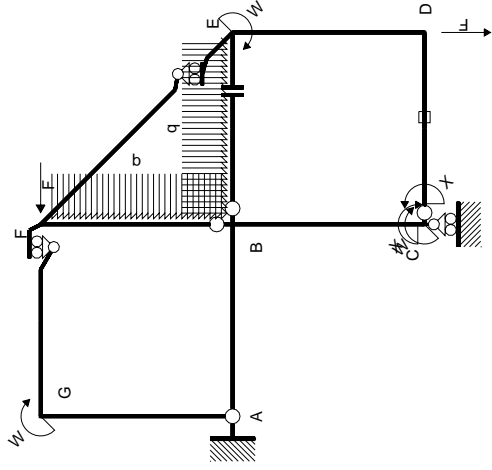

Schema di calcolo iperstatico

M_0 flessione da carichi assegnati

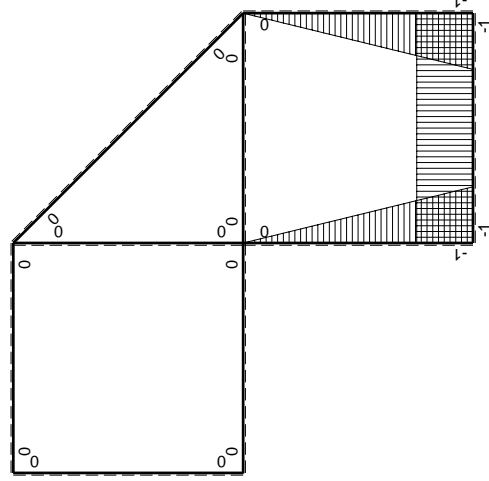

M_x flessione da iperstatica X=1

Quadro contribuiti PLV per iperstatica X=W_{cd}

→	$M_x(x)$	$M_0(x)$	$M_x M_0$	$M_x M_x$	$\int M_x M_0 / EJ dx$	$\int X M_x M_x / EJ dx$
AB b	0	-2Fx	0	0	0	0
BA b	0	2Fb-2Fx	0	0	0	0
BC b	-x/b	-2Fb+Fx	2Fx-Fx ² /b	x ² /b ²	2/3Fb ² /EJ	1/3Xb/EJ
CB b	1-x/b	Fb+Fx	Fb-Fx ² /b	1-2x/b+x ² /b ²	1/4Fb ² /EJ	Xb/EJ
CD b	-1	-1/2Fx	1/2Fx	1	1/4Fb ² /EJ	Xb/EJ
DC b	1	1/2Fb-1/2Fx	1/2Fb-1/2Fx	1	1/4Fb ² /EJ	Xb/EJ
DE b	-1+x/b	-1/2Fb-Fx	1/2Fb+1/2Fx-Fx ² /b	1-2x/b+x ² /b ²	5/12Fb ² /EJ	1/3Xb/EJ
ED b	x/b	3/2Fb-Fx	3/2Fx-Fx ² /b	x ² /b ²	5/12Fb ² /EJ	1/3Xb/EJ
EF √2b	0	3√2/4Fx	0	0	0	0
FG b	0	-Fx	0	0	0	0
GF b	0	Fb-Fx	0	0	0	0
GA b	0	0	0	0	0	0
AG b	0	0	0	0	0	0
FB b	0	3/2Fb-Fx-1/2qx ²	0	0	0	0
BF b	0	-2Fx+1/2qx ²	0	0	0	0
BE b	0	Fx-1/2qx ²	0	0	0	0
EB b	0	-1/2Fb+1/2qx ²	0	0	0	0
CD	elongazione asta $N_{1,cd} \epsilon_{cd} L_{cd}$				-Fb ² /EJ	
	totali				1/3Fb ² /EJ	5/3Xb/EJ
	iperstatica X=W _{cd}				-1/5Fb	

Sviluppi di calcolo iperstatica

$$L_{BC}^{xx} = \int_0^b (x^2/b^2) 1/EJ dx = [1/3 x^3/b^2]_0^b 1/EJ$$

$$= (1/3 b) 1/EJ = 1/3 b/EJ$$

$$L_{CB}^{xx} = \int_0^b (1 - 2x/b + x^2/b^2) 1/EJ dx = [x - x^2/b + 1/3 x^3/b^2]_0^b 1/EJ$$

$$= (b - b + 1/3 b) 1/EJ = 1/3 b/EJ$$

$$L_{CD}^{xx} = \int_0^b (1) 1/EJ dx = [x]_0^b 1/EJ$$

$$= (b) 1/EJ = b/EJ$$

$$L_{DC}^{xx} = \int_0^b (1) 1/EJ dx = [x]_0^b 1/EJ$$

$$= (b) 1/EJ = b/EJ$$

$$L_{DE}^{xx} = \int_0^b (1 - 2x/b + x^2/b^2) 1/EJ dx = [x - x^2/b + 1/3 x^3/b^2]_0^b 1/EJ$$

$$= (b - b + 1/3 b) 1/EJ = 1/3 b/EJ$$

$$L_{ED}^{xx} = \int_0^b (x^2/b^2) 1/EJ dx = [1/3 x^3/b^2]_0^b 1/EJ$$

$$= (1/3 b) 1/EJ = 1/3 b/EJ$$

$$L_{BC}^{x_0} = \int_0^b (2x/b - x^2/b^2) Fb 1/EJ dx = [x^2/b - 1/3 x^3/b^2]_0^b Fb 1/EJ$$

$$= (b - 1/3 b) Fb 1/EJ = 2/3 Fb^2/EJ$$

$$L_{CB}^{x_0} = \int_0^b (1 - x^2/b^2) Fb 1/EJ dx = [x - 1/3 x^3/b^2]_0^b Fb 1/EJ$$

$$= (b - 1/3 b) Fb 1/EJ = 2/3 Fb^2/EJ$$

$$L_{CD}^{x_0} = \int_0^b (1/2 x/b) Fb 1/EJ dx + 1 (-1) 1 Fb^2/EJ = [1/4 x^2/b]_0^b Fb 1/EJ + 1 (-1) 1 Fb^2/EJ$$

$$= (1/4 b) Fb 1/EJ + 1 (-1) 1 Fb^2/EJ = -3/4 Fb^2/EJ$$

$$L_{DC}^{x_0} = \int_0^b (1/2 - 1/2 x/b) Fb 1/EJ dx + 1 (-1) 1 Fb^2/EJ = [1/2 x - 1/4 x^2/b]_0^b Fb 1/EJ + 1 (-1) 1 Fb^2/EJ$$

$$= (1/2 b - 1/4 b) Fb 1/EJ + 1 (-1) 1 Fb^2/EJ = -3/4 Fb^2/EJ$$

$$L_{DE}^{x_0} = \int_0^b (1/2 + 1/2 x/b - x^2/b^2) Fb 1/EJ dx = [1/2 x + 1/4 x^2/b - 1/3 x^3/b^2]_0^b Fb 1/EJ$$

$$= (1/2 b + 1/4 b - 1/3 b) Fb 1/EJ = 5/12 Fb^2/EJ$$

$$L_{ED}^{x_0} = \int_0^b (3/2 x/b - x^2/b^2) Fb 1/EJ dx = [3/4 x^2/b - 1/3 x^3/b^2]_0^b Fb 1/EJ$$

$$= (3/4 b - 1/3 b) Fb 1/EJ = 5/12 Fb^2/EJ$$

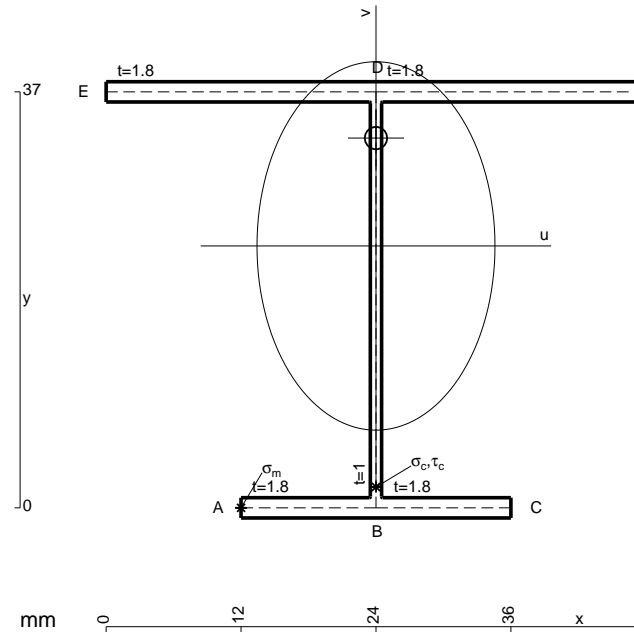

- A = 166.6 mm²
- J_u = 44743. mm⁴
- J_v = 18662. mm⁴
- J_t = 152.3 mm⁴
- y_o = 9.592 mm
- y_g = 23.3 mm
- N = -1060. N
- T_y = -1060. N
- M_x = -371000. Nmm
- x_m = 12. mm
- u_m = -12. mm
- v_m = -23.3 mm
- σ_m = N/A-Mv/J_u = -199.5 N/mm²
- x_c = 24. mm
- v_c = -23.3 mm
- σ_c = N/A-Mv/J_u = -199.5 N/mm²
- τ_c = TS'/tJ_u = 23.84 N/mm²
- τ_g = TS'/tJ_u = 23.84 N/mm²
- t_c = 530. mm
- σ_o = √σ²+3τ² = 203.8 N/mm²

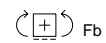
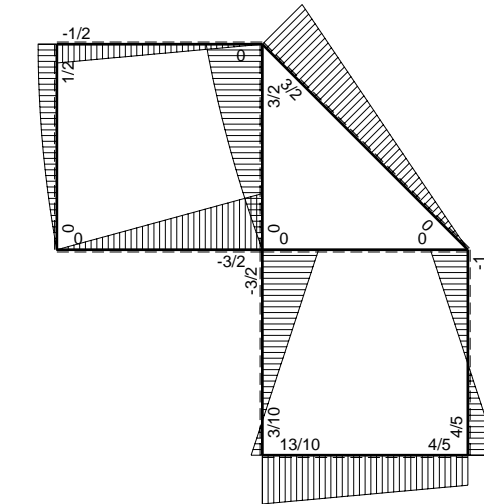
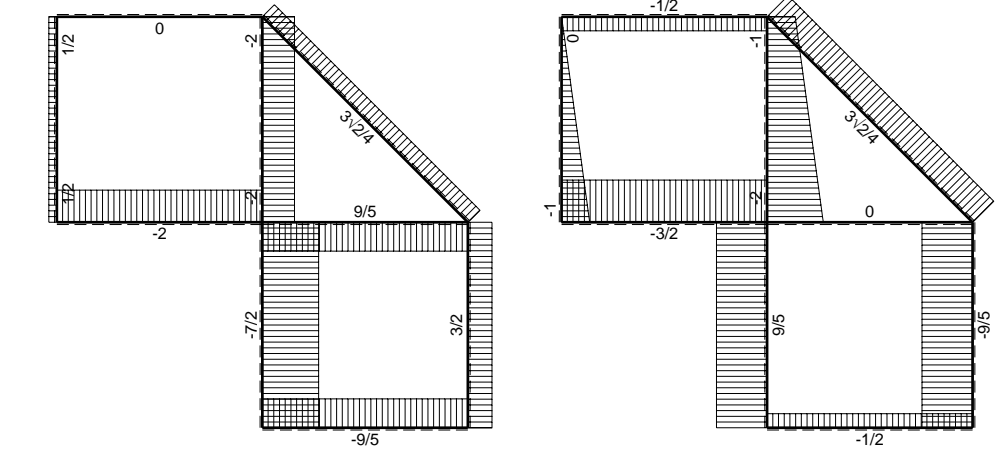
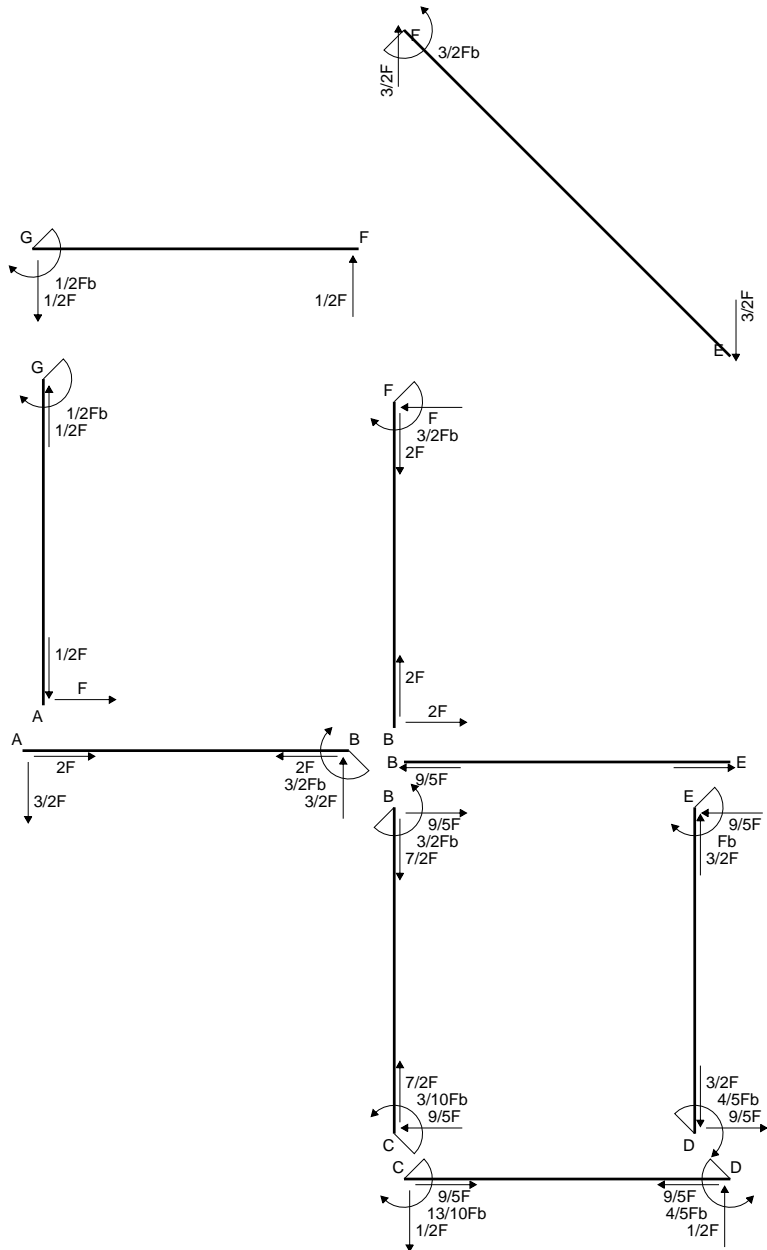

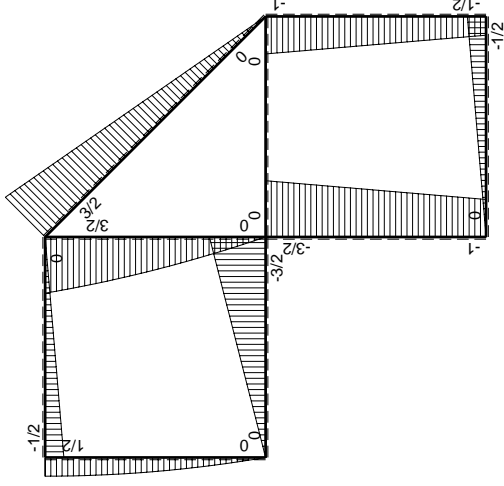
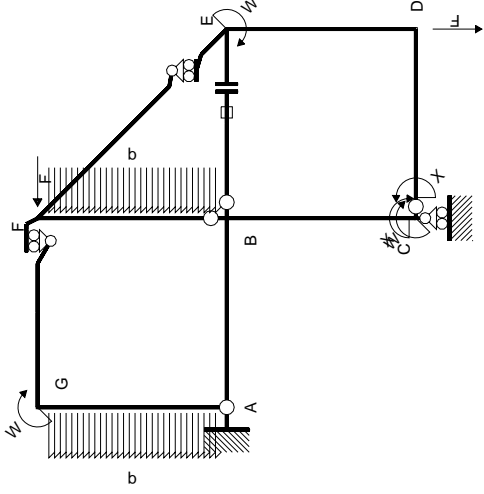

Schema di calcolo iperstatico

M_0 flessione da carichi assegnati

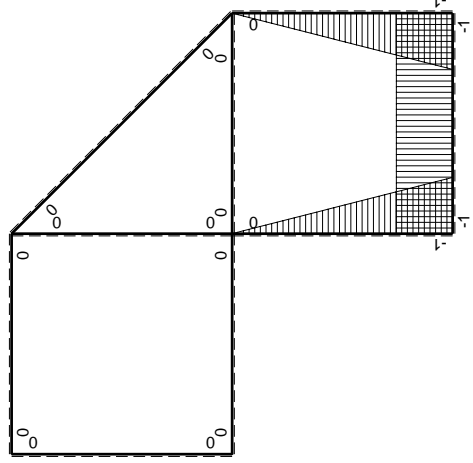

M_x flessione da iperstatica $X=1$

Quadro contribuiti PLV per iperstatica $X=W_{cd}$

\rightarrow	$M_x(x)$	$M_0(x)$	$M_x M_0$	$M_x M_x$	$\int M_x M_0 / E J dx$	$\int M_x M_x / E J dx$
AB b	0	-3/2Fx	0	0	0	0
BA b	0	3/2Fb-3/2Fx	0	0	0	0
BC b	-x/b	-3/2Fb+1/2Fx	3/2Fx-1/2Fx ² /b	x ² /b ²	7/12Fb ² /EJ	1/3Xb/EJ
CB b	1-x/b	Fb+1/2Fx	Fb-1/2Fx-1/2Fx ² /b	1-2x/b+x ² /b ²	1/4Fb ² /EJ	Xb/EJ
CD b	-1	-1/2Fx	1/2Fx	1	1/4Fb ² /EJ	Xb/EJ
DC b	1	1/2Fb-1/2Fx	1/2Fb-1/2Fx	1	1/3Fb ² /EJ	1/3Xb/EJ
DE b	-1+x/b	-1/2Fb-1/2Fx	1/2Fb-1/2Fx ² /b	1-2x/b+x ² /b ²	1/3Fb ² /EJ	1/3Xb/EJ
ED b	x/b	Fb-1/2Fx	Fx-1/2Fx ² /b	x ² /b ²	0	0
EF $\sqrt{2}b$	0	3 $\sqrt{2}$ /4Fx	0	0	0	0
FG b	0	-1/2Fx	0	0	0	0
GF b	0	1/2Fb-1/2Fx	0	0	0	0
GA b	0	1/2Fb-1/2qx ²	0	0	0	0
AG b	0	-Fx+1/2qx ²	0	0	0	0
FB b	0	3/2Fb-Fx-1/2qx ²	0	0	0	0
BF b	0	-2Fx+1/2qx ²	0	0	0	0
BE b	0	0	0	0	0	0
EB b	0	0	0	0	0	0
BE	elongazione asta $N_{1, BE} \epsilon_{BE} L_{BE}$				Fb ² /EJ	
	totali				13/6Fb ² /EJ	5/3Xb/EJ
	iperstatica $X=W_{cd}$				-13/10Fb	

Sviluppi di calcolo iperstatica

$$L_{BC}^{xx} = \int_0^b (x^2/b^2) 1/EJ dx = [1/3 x^3/b^2]_0^b 1/EJ$$

$$= (1/3 b) 1/EJ = 1/3 b/EJ$$

$$L_{CB}^{xx} = \int_0^b (1 - 2x/b + x^2/b^2) 1/EJ dx = [x - x^2/b + 1/3 x^3/b^2]_0^b 1/EJ$$

$$= (b - b + 1/3 b) 1/EJ = 1/3 b/EJ$$

$$L_{CD}^{xx} = \int_0^b (1) 1/EJ dx = [x]_0^b 1/EJ$$

$$= (b) 1/EJ = b/EJ$$

$$L_{DC}^{xx} = \int_0^b (1) 1/EJ dx = [x]_0^b 1/EJ$$

$$= (b) 1/EJ = b/EJ$$

$$L_{DE}^{xx} = \int_0^b (1 - 2x/b + x^2/b^2) 1/EJ dx = [x - x^2/b + 1/3 x^3/b^2]_0^b 1/EJ$$

$$= (b - b + 1/3 b) 1/EJ = 1/3 b/EJ$$

$$L_{ED}^{xx} = \int_0^b (x^2/b^2) 1/EJ dx = [1/3 x^3/b^2]_0^b 1/EJ$$

$$= (1/3 b) 1/EJ = 1/3 b/EJ$$

$$L_{BC}^{xo} = \int_0^b (3/2 x/b - 1/2 x^2/b^2) Fb 1/EJ dx = [3/4 x^2/b - 1/6 x^3/b^2]_0^b Fb 1/EJ$$

$$= (3/4 b - 1/6 b) Fb 1/EJ = 7/12 Fb^2/EJ$$

$$L_{CB}^{xo} = \int_0^b (1 - 1/2 x/b - 1/2 x^2/b^2) Fb 1/EJ dx = [x - 1/4 x^2/b - 1/6 x^3/b^2]_0^b Fb 1/EJ$$

$$= (b - 1/4 b - 1/6 b) Fb 1/EJ = 7/12 Fb^2/EJ$$

$$L_{CD}^{xo} = \int_0^b (1/2 x/b) Fb 1/EJ dx = [1/4 x^2/b]_0^b Fb 1/EJ$$

$$= (1/4 b) Fb 1/EJ = 1/4 Fb^2/EJ$$

$$L_{DC}^{xo} = \int_0^b (1/2 - 1/2 x/b) Fb 1/EJ dx = [1/2 x - 1/4 x^2/b]_0^b Fb 1/EJ$$

$$= (1/2 b - 1/4 b) Fb 1/EJ = 1/4 Fb^2/EJ$$

$$L_{DE}^{xo} = \int_0^b (1/2 - 1/2 x^2/b^2) Fb 1/EJ dx = [1/2 x - 1/6 x^3/b^2]_0^b Fb 1/EJ$$

$$= (1/2 b - 1/6 b) Fb 1/EJ = 1/3 Fb^2/EJ$$

$$L_{ED}^{xo} = \int_0^b (x/b - 1/2 x^2/b^2) Fb 1/EJ dx = [1/2 x^2/b - 1/6 x^3/b^2]_0^b Fb 1/EJ$$

$$= (1/2 b - 1/6 b) Fb 1/EJ = 1/3 Fb^2/EJ$$

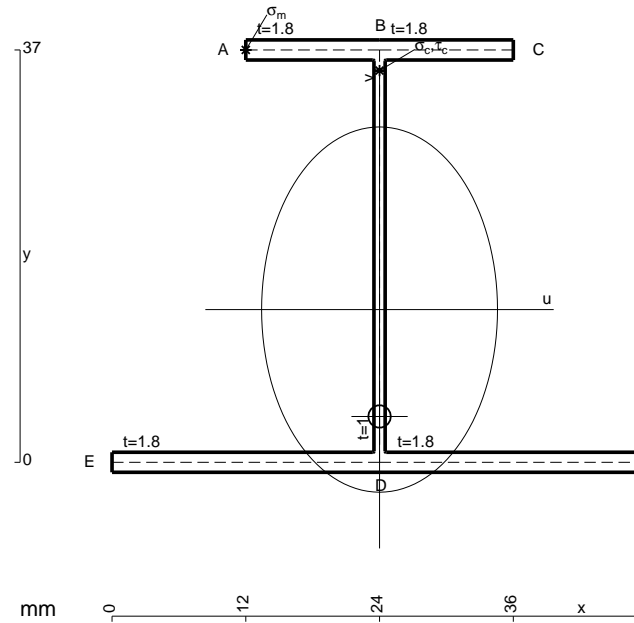

- A = 166.6 mm²
- J_u = 44743. mm⁴
- J_v = 18662. mm⁴
- J_t = 152.3 mm⁴
- y_o = -9.592 mm
- y_g = 13.7 mm
- N = -1460. N
- T_y = -1095. N
- M_x = -416100. Nmm
- x_m = 12. mm
- y_m = 37. mm
- u_m = -12. mm
- v_m = 23.3 mm
- σ_m = N/A - M_v/J_u = 207.9 N/mm²
- x_c = 24. mm
- y_c = 37. mm
- v_c = 23.3 mm
- σ_c = N/A - M_v/J_u = 207.9 N/mm²
- τ_c = T_s/t_u = 24.63 N/mm²
- τ_g = T_s/t_u = 24.63 N/mm²
- t_c = 730. mm
- σ_o = √(σ² + 3τ²) = 212.2 N/mm²

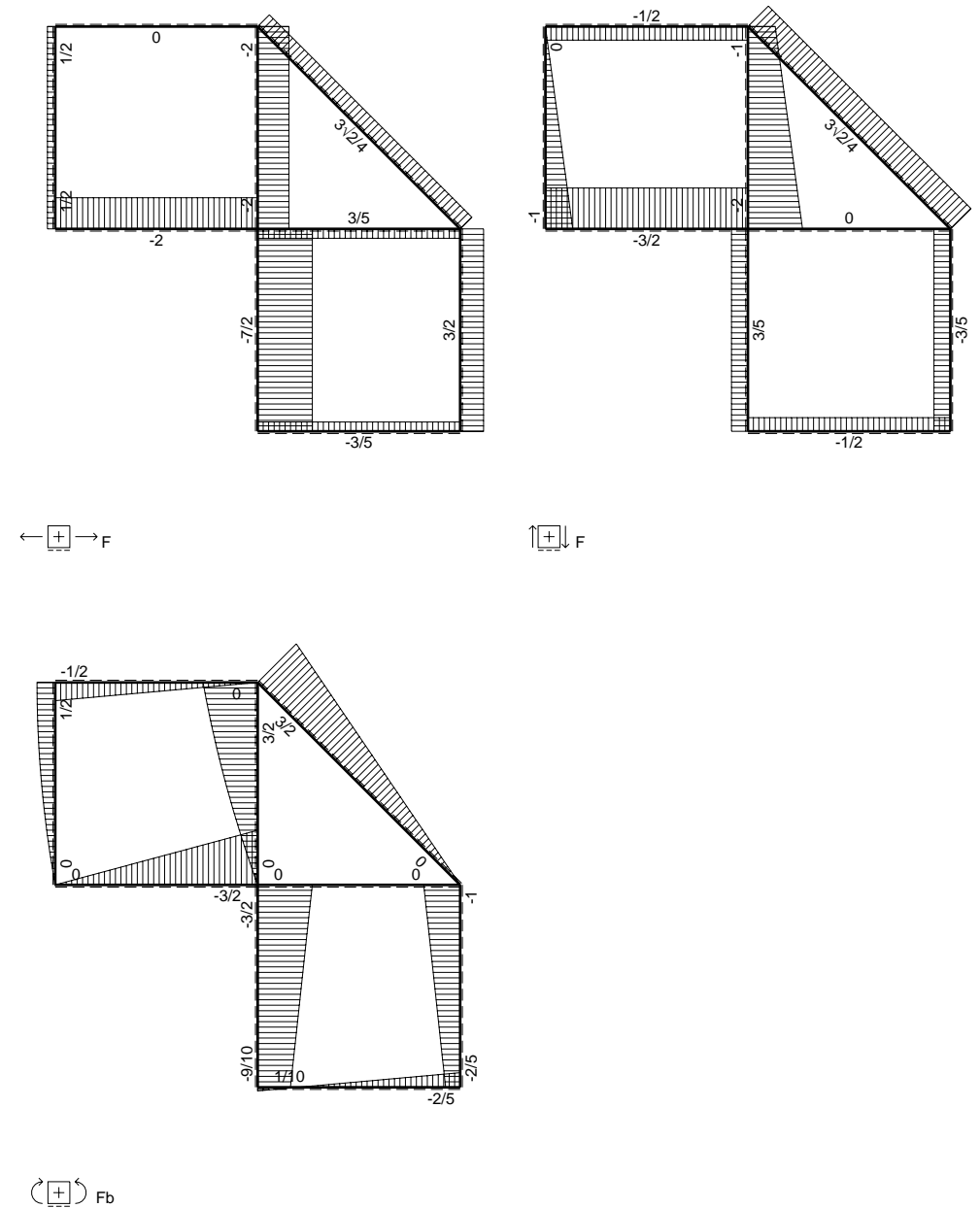
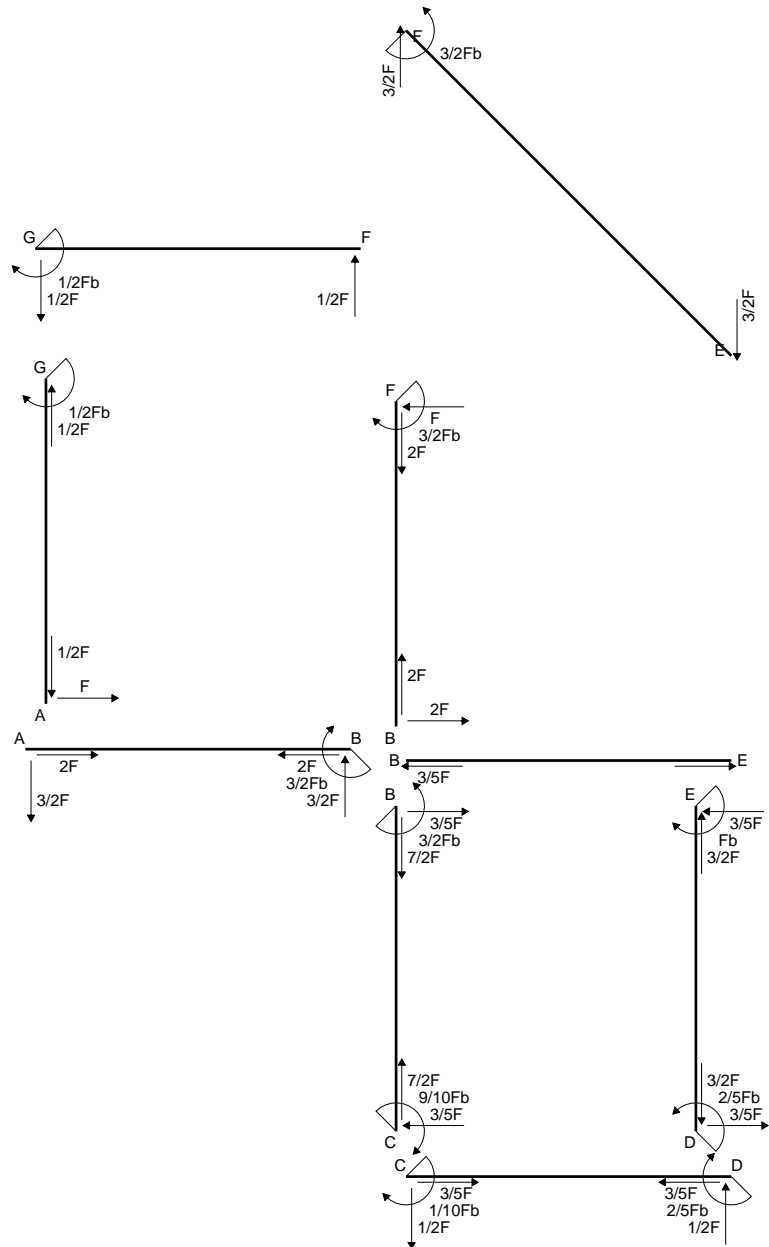

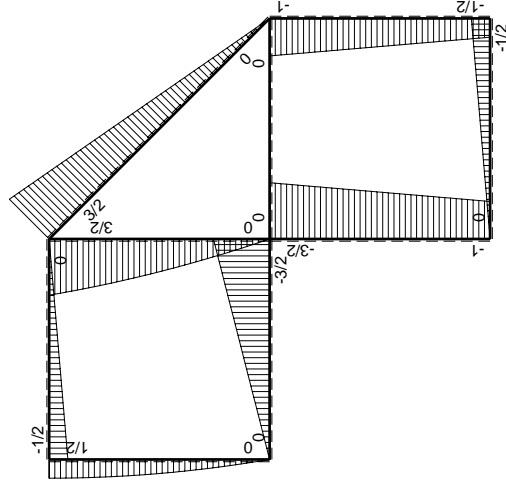
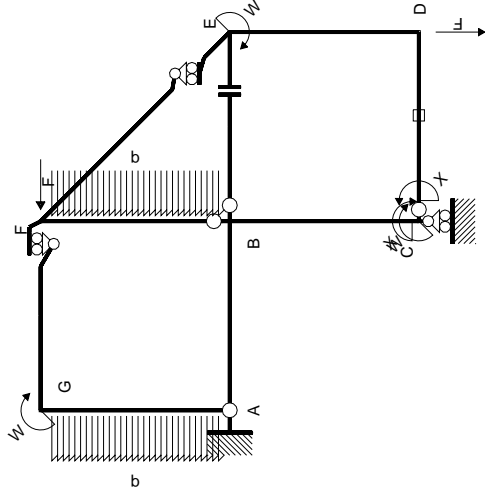

Schema di calcolo iperstatico

M_0 flessione da carichi assegnati

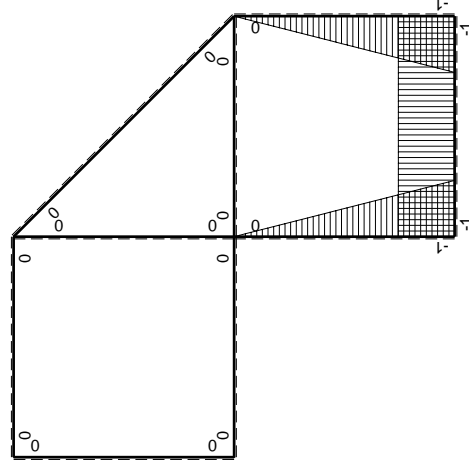

M_x flessione da iperstatica $X=1$

Quadro contribuiti PLV per iperstatica $X=W_{cd}$

\rightarrow	$M_x(x)$	$M_0(x)$	$M_x M_0$	$M_x M_x$	$\int M_x M_0 / E J dx$	$\int M_x M_x / E J dx$
AB b	0	$-3/2Fx$	0	0	0	0
BA b	0	$3/2Fb-3/2Fx$	0	0	0	0
BC b	$-x/b$	$-3/2Fb+1/2Fx$	$3/2Fx-1/2Fx^2/b$	x^2/b^2	$7/12Fb^2/EJ$	$1/3Xb/EJ$
CB b	$1-x/b$	$Fb+1/2Fx$	$Fb-1/2Fx-1/2Fx^2/b$	$1-2x/b+x^2/b^2$	$1/4Fb^2/EJ$	Xb/EJ
CD b	-1	$-1/2Fx$	$1/2Fx$	1	$1/4Fb^2/EJ$	Xb/EJ
DC b	1	$1/2Fb-1/2Fx$	$1/2Fb-1/2Fx$	1	$1/4Fb^2/EJ$	Xb/EJ
DE b	$-1+x/b$	$-1/2Fb-1/2Fx$	$1/2Fb-1/2Fx^2/b$	$1-2x/b+x^2/b^2$	$1/3Fb^2/EJ$	$1/3Xb/EJ$
ED b	x/b	$Fb-1/2Fx$	$Fx-1/2Fx^2/b$	x^2/b^2	0	0
EF $\sqrt{2}b$	0	$3\sqrt{2}/4Fx$	0	0	0	0
FG b	0	$-1/2Fx$	0	0	0	0
GF b	0	$1/2Fb-1/2Fx$	0	0	0	0
GA b	0	$1/2Fb-1/2qx^2$	0	0	0	0
AG b	0	$-Fx+1/2qx^2$	0	0	0	0
FB b	0	$3/2Fb-Fx-1/2qx^2$	0	0	0	0
BF b	0	$-2Fx+1/2qx^2$	0	0	0	0
BE b	0	0	0	0	0	0
EB b	0	0	0	0	0	0
CD	elongazione asta $N_{1,cd} \epsilon_{cd} L_{cd}$				$-Fb^2/EJ$	
	totali				$1/6Fb^2/EJ$	$5/3Xb/EJ$
	iperstatica $X=W_{cd}$				$-1/10Fb$	

Sviluppi di calcolo iperstatica

$$L_{BC}^{xx} = \int_0^b (x^2/b^2) 1/EJ dx = [1/3 x^3/b^2]_0^b 1/EJ$$

$$= (1/3 b) 1/EJ = 1/3 b/EJ$$

$$L_{CB}^{xx} = \int_0^b (1 - 2x/b + x^2/b^2) 1/EJ dx = [x - x^2/b + 1/3 x^3/b^2]_0^b 1/EJ$$

$$= (b - b + 1/3 b) 1/EJ = 1/3 b/EJ$$

$$L_{CD}^{xx} = \int_0^b (1) 1/EJ dx = [x]_0^b 1/EJ$$

$$= (b) 1/EJ = b/EJ$$

$$L_{DC}^{xx} = \int_0^b (1) 1/EJ dx = [x]_0^b 1/EJ$$

$$= (b) 1/EJ = b/EJ$$

$$L_{DE}^{xx} = \int_0^b (1 - 2x/b + x^2/b^2) 1/EJ dx = [x - x^2/b + 1/3 x^3/b^2]_0^b 1/EJ$$

$$= (b - b + 1/3 b) 1/EJ = 1/3 b/EJ$$

$$L_{ED}^{xx} = \int_0^b (x^2/b^2) 1/EJ dx = [1/3 x^3/b^2]_0^b 1/EJ$$

$$= (1/3 b) 1/EJ = 1/3 b/EJ$$

$$L_{BC}^{xo} = \int_0^b (3/2 x/b - 1/2 x^2/b^2) Fb 1/EJ dx = [3/4 x^2/b - 1/6 x^3/b^2]_0^b Fb 1/EJ$$

$$= (3/4 b - 1/6 b) Fb 1/EJ = 7/12 Fb^2/EJ$$

$$L_{CB}^{xo} = \int_0^b (1 - 1/2 x/b - 1/2 x^2/b^2) Fb 1/EJ dx = [x - 1/4 x^2/b - 1/6 x^3/b^2]_0^b Fb 1/EJ$$

$$= (b - 1/4 b - 1/6 b) Fb 1/EJ = 7/12 Fb^2/EJ$$

$$L_{CD}^{xo} = \int_0^b (1/2 x/b) Fb 1/EJ dx + 1 (-1) 1 Fb^2/EJ = [1/4 x^2/b]_0^b Fb 1/EJ + 1 (-1) 1 Fb^2/EJ$$

$$= (1/4 b) Fb 1/EJ + 1 (-1) 1 Fb^2/EJ = -3/4 Fb^2/EJ$$

$$L_{DC}^{xo} = \int_0^b (1/2 - 1/2 x/b) Fb 1/EJ dx + 1 (-1) 1 Fb^2/EJ = [1/2 x - 1/4 x^2/b]_0^b Fb 1/EJ + 1 (-1) 1 Fb^2/EJ$$

$$= (1/2 b - 1/4 b) Fb 1/EJ + 1 (-1) 1 Fb^2/EJ = -3/4 Fb^2/EJ$$

$$L_{DE}^{xo} = \int_0^b (1/2 - 1/2 x^2/b^2) Fb 1/EJ dx = [1/2 x - 1/6 x^3/b^2]_0^b Fb 1/EJ$$

$$= (1/2 b - 1/6 b) Fb 1/EJ = 1/3 Fb^2/EJ$$

$$L_{ED}^{xo} = \int_0^b (x/b - 1/2 x^2/b^2) Fb 1/EJ dx = [1/2 x^2/b - 1/6 x^3/b^2]_0^b Fb 1/EJ$$

$$= (1/2 b - 1/6 b) Fb 1/EJ = 1/3 Fb^2/EJ$$

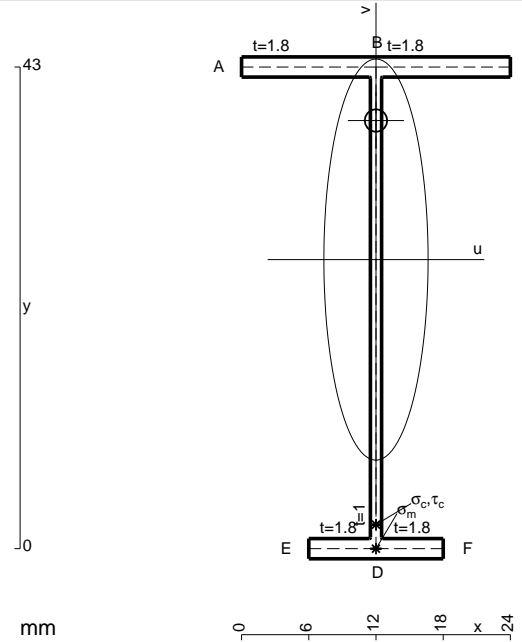

- A = 107.8 mm²
- J_u = 34579. mm⁴
- J_v = 2333. mm⁴
- J_t = 84.32 mm⁴
- y_o = 12.41 mm
- y_g = 25.81 mm
- N = -760. N
- T_y = -570. N
- M_x = -279300. Nmm
- x_m = 12. mm
- v_m = -25.81 mm
- σ_m = N/A-Mv/J_u = -215.5 N/mm²
- y_c = 3. mm
- u_c = -12. mm
- v_c = -22.81 mm
- σ_c = N/A-Mv/J_u = -215.5 N/mm²
- τ_c = TS¹/tJ_u = 9.189 N/mm²
- τ_g = TS¹/tJ_u = 9.189 N/mm²
- t_c = 380. mm
- σ_o = √σ²+3τ² = 216.1 N/mm²

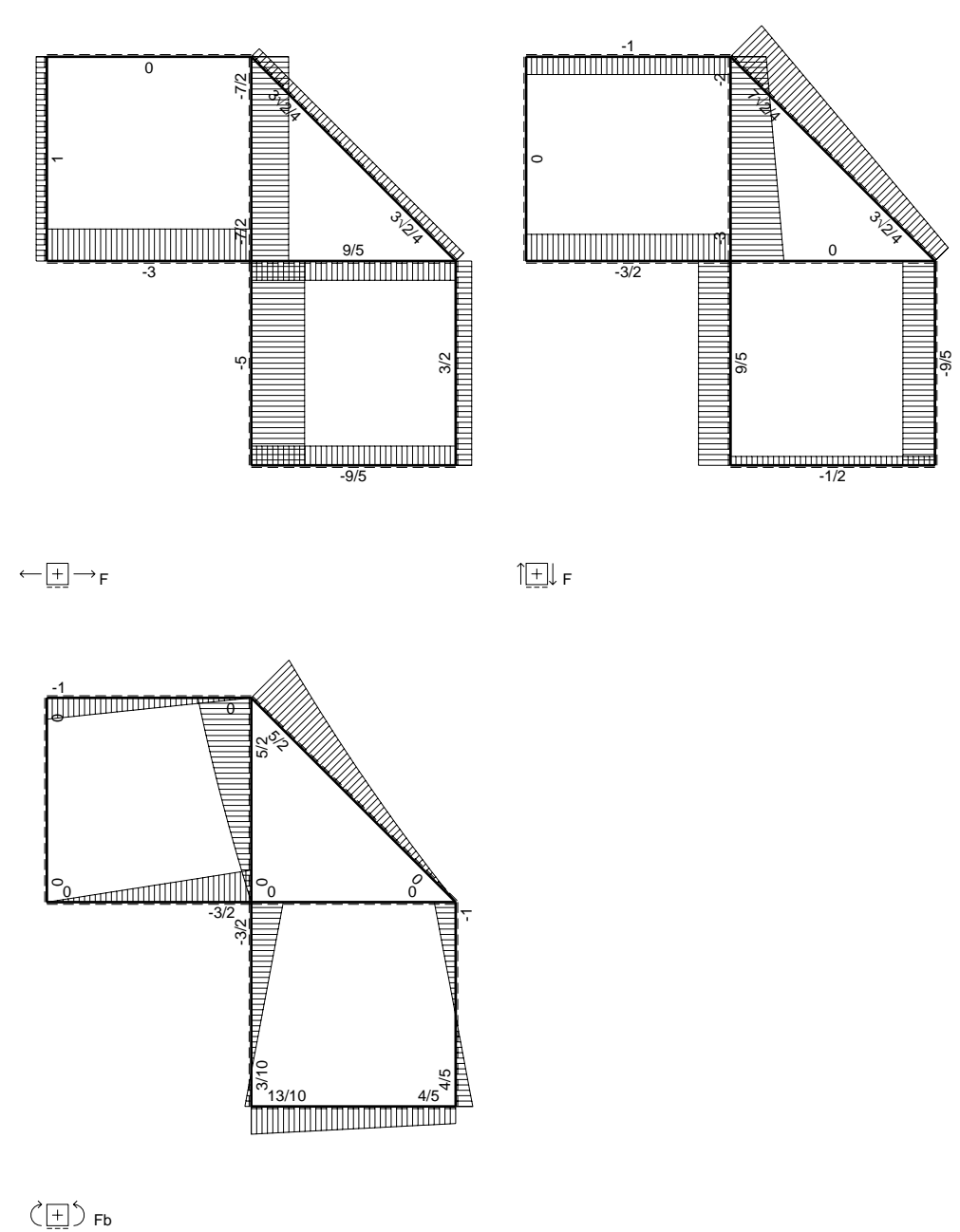
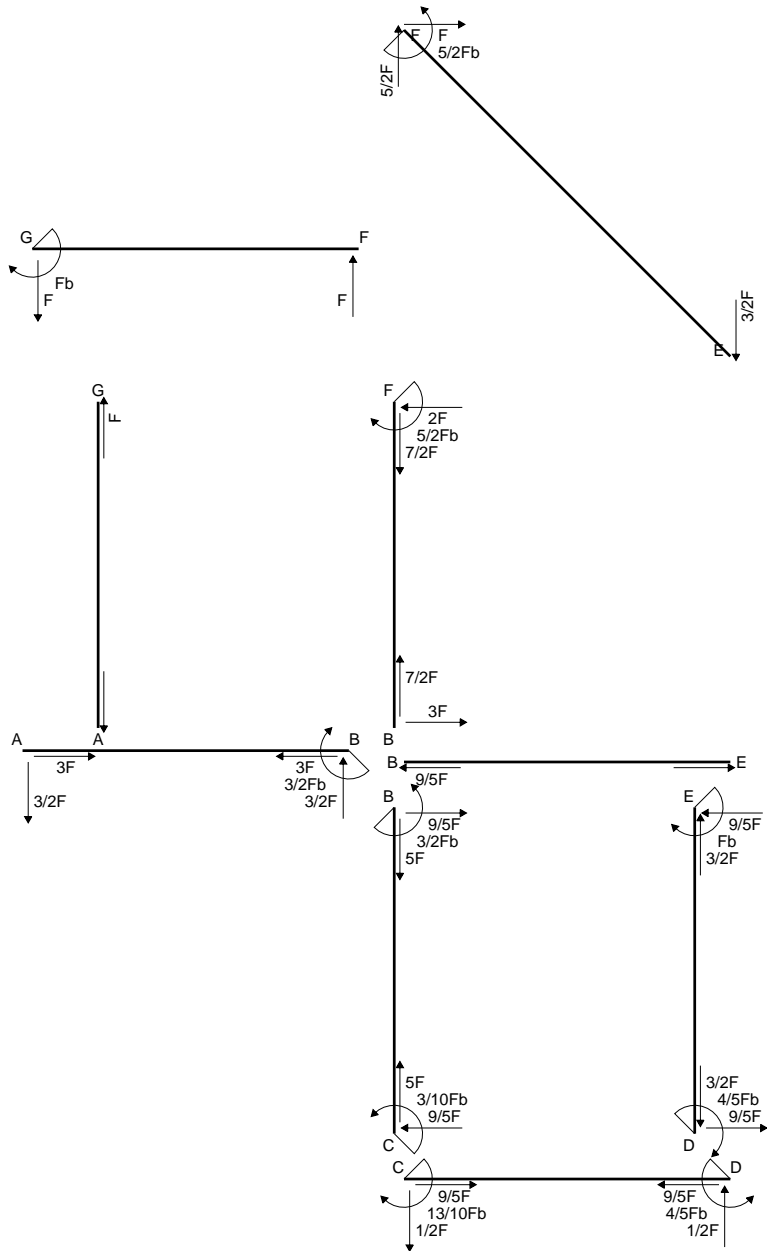

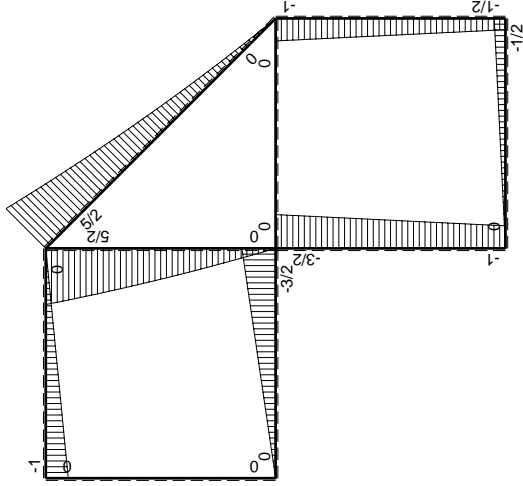
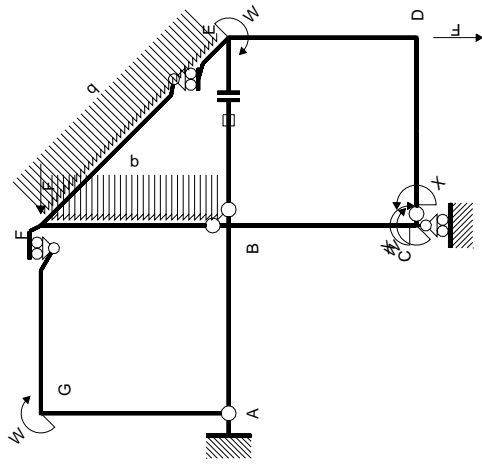

Schema di calcolo iperstatico

M_0 flessione da carichi assegnati

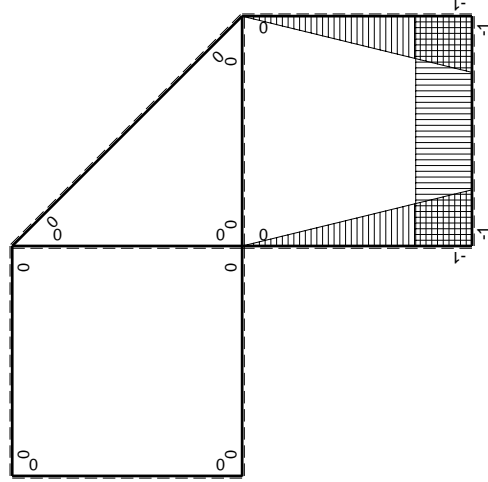

M_x flessione da iperstatica $X=1$

Quadro contribuiti PLV per iperstatica $X=W_{cd}$

\rightarrow	$M_x(x)$	$M_0(x)$	$M_x M_0$	$M_x M_x$	$\int M_x M_0 / EJ dx$	$\int X M_x M_x / EJ dx$
AB b	0	-3/2Fx	0	0	0	0
BA b	0	3/2Fb-3/2Fx	0	0	0	0
BC b	-x/b	-3/2Fb+1/2Fx	3/2Fx-1/2Fx ² /b	x ² /b ²	7/12Fb ² /EJ	1/3Xb/EJ
CB b	1-x/b	Fb+1/2Fx	Fb-1/2Fx-1/2Fx ² /b	1-2x/b+x ² /b ²	1/4Fb ² /EJ	Xb/EJ
CD b	-1	-1/2Fx	1/2Fx	1	1/4Fb ² /EJ	Xb/EJ
DC b	1	1/2Fb-1/2Fx	1/2Fb-1/2Fx	1	1/4Fb ² /EJ	Xb/EJ
DE b	-1+x/b	-1/2Fb-1/2Fx	1/2Fb-1/2Fx ² /b	1-2x/b+x ² /b ²	1/3Fb ² /EJ	1/3Xb/EJ
ED b	x/b	Fb-1/2Fx	Fx-1/2Fx ² /b	x ² /b ²	1/3Fb ² /EJ	1/3Xb/EJ
EF $\sqrt{2}b$	0	3\sqrt{2}4Fx+1/2qx ²	0	0	0	0
FG b	0	-Fx	0	0	0	0
GF b	0	Fb-Fx	0	0	0	0
GA b	0	0	0	0	0	0
AG b	0	0	0	0	0	0
FB b	0	5/2Fb-2Fx-1/2qx ²	0	0	0	0
BF b	0	-3Fx+1/2qx ²	0	0	0	0
BE b	0	0	0	0	0	0
EB b	0	0	0	0	0	0
BE	elongazione asta $N_{1, BE}^{\epsilon} L_{BE}^{\epsilon}$				Fb ² /EJ	
	totali				13/6Fb ² /EJ	5/3Xb/EJ
	iperstatica $X=W_{cd}$				-13/10Fb	

Sviluppi di calcolo iperstatica

$$L_{BC}^{xx} = \int_0^b (x^2/b^2) 1/EJ dx = [1/3 x^3/b^2]_0^b 1/EJ$$

$$= (1/3 b) 1/EJ = 1/3 b/EJ$$

$$L_{CB}^{xx} = \int_0^b (1 - 2x/b + x^2/b^2) 1/EJ dx = [x - x^2/b + 1/3 x^3/b^2]_0^b 1/EJ$$

$$= (b - b + 1/3 b) 1/EJ = 1/3 b/EJ$$

$$L_{CD}^{xx} = \int_0^b (1) 1/EJ dx = [x]_0^b 1/EJ$$

$$= (b) 1/EJ = b/EJ$$

$$L_{DC}^{xx} = \int_0^b (1) 1/EJ dx = [x]_0^b 1/EJ$$

$$= (b) 1/EJ = b/EJ$$

$$L_{DE}^{xx} = \int_0^b (1 - 2x/b + x^2/b^2) 1/EJ dx = [x - x^2/b + 1/3 x^3/b^2]_0^b 1/EJ$$

$$= (b - b + 1/3 b) 1/EJ = 1/3 b/EJ$$

$$L_{ED}^{xx} = \int_0^b (x^2/b^2) 1/EJ dx = [1/3 x^3/b^2]_0^b 1/EJ$$

$$= (1/3 b) 1/EJ = 1/3 b/EJ$$

$$L_{BC}^{xo} = \int_0^b (3/2 x/b - 1/2 x^2/b^2) Fb 1/EJ dx = [3/4 x^2/b - 1/6 x^3/b^2]_0^b Fb 1/EJ$$

$$= (3/4 b - 1/6 b) Fb 1/EJ = 7/12 Fb^2/EJ$$

$$L_{CB}^{xo} = \int_0^b (1 - 1/2 x/b - 1/2 x^2/b^2) Fb 1/EJ dx = [x - 1/4 x^2/b - 1/6 x^3/b^2]_0^b Fb 1/EJ$$

$$= (b - 1/4 b - 1/6 b) Fb 1/EJ = 7/12 Fb^2/EJ$$

$$L_{CD}^{xo} = \int_0^b (1/2 x/b) Fb 1/EJ dx = [1/4 x^2/b]_0^b Fb 1/EJ$$

$$= (1/4 b) Fb 1/EJ = 1/4 Fb^2/EJ$$

$$L_{DC}^{xo} = \int_0^b (1/2 - 1/2 x/b) Fb 1/EJ dx = [1/2 x - 1/4 x^2/b]_0^b Fb 1/EJ$$

$$= (1/2 b - 1/4 b) Fb 1/EJ = 1/4 Fb^2/EJ$$

$$L_{DE}^{xo} = \int_0^b (1/2 - 1/2 x^2/b^2) Fb 1/EJ dx = [1/2 x - 1/6 x^3/b^2]_0^b Fb 1/EJ$$

$$= (1/2 b - 1/6 b) Fb 1/EJ = 1/3 Fb^2/EJ$$

$$L_{ED}^{xo} = \int_0^b (x/b - 1/2 x^2/b^2) Fb 1/EJ dx = [1/2 x^2/b - 1/6 x^3/b^2]_0^b Fb 1/EJ$$

$$= (1/2 b - 1/6 b) Fb 1/EJ = 1/3 Fb^2/EJ$$

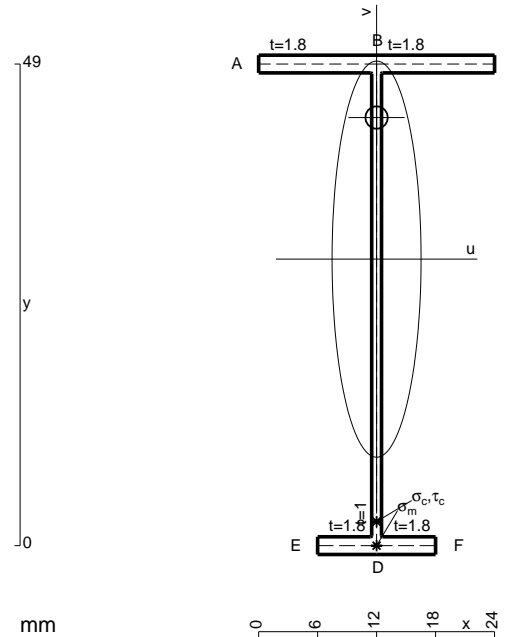

- A = 113.8 mm²
- J_u = 46239. mm⁴
- J_v = 2333. mm⁴
- J_t = 86.32 mm⁴
- y_o = 14.41 mm
- y_g = 29.15 mm
- N = 254.6 N
- T_y = 594. N
- M_x = 354000. Nmm
- x_m = 12. mm
- v_m = -29.15 mm
- σ_m = N/A-Mv/J_u = 225.4 N/mm²
- y_c = 3. mm
- u_c = -12. mm
- v_c = -26.15 mm
- σ_c = N/A-Mv/J_u = 225.4 N/mm²
- τ_c = TS'/tJ_u = 8.088 N/mm²
- τ_g = TS'/tJ_u = 8.088 N/mm²
- t_c = 240. mm
- σ_o = √σ²+3τ² = 225.8 N/mm²

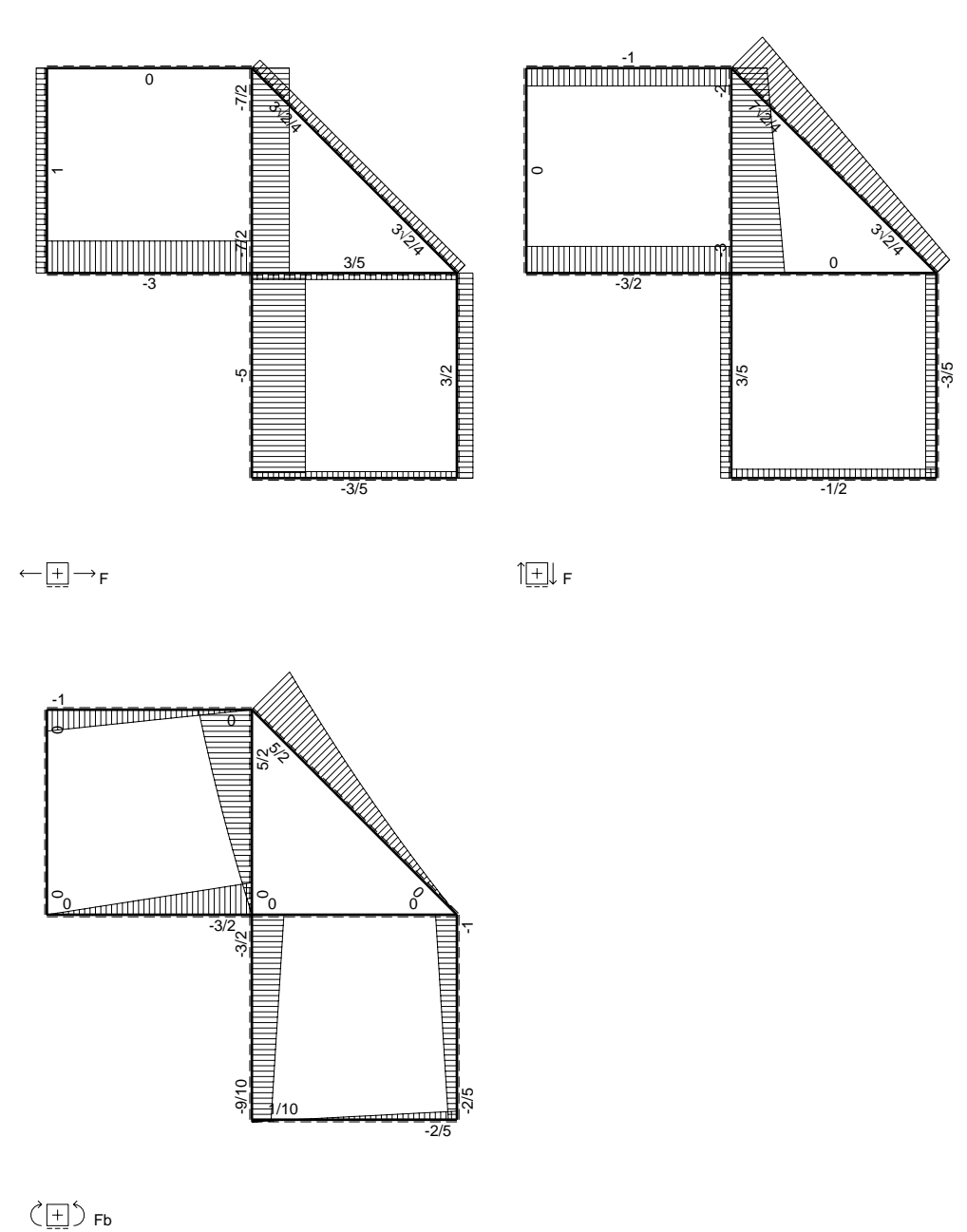
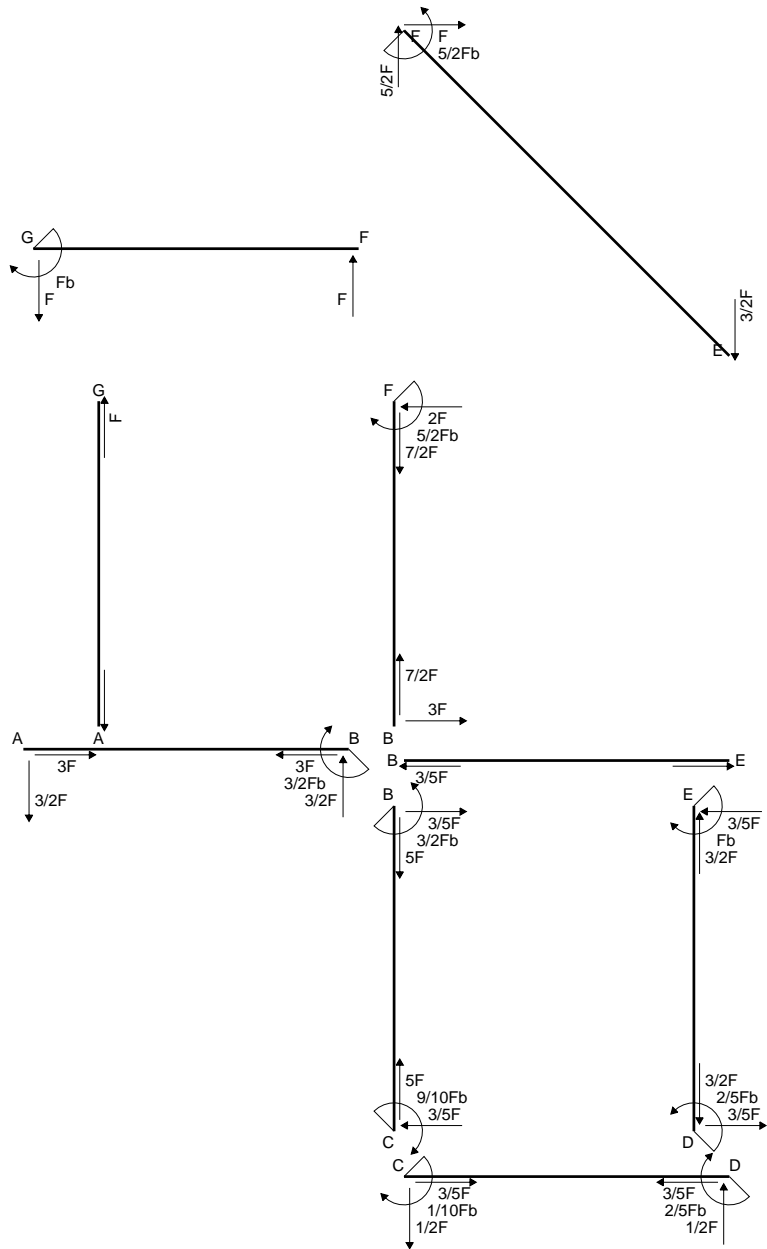

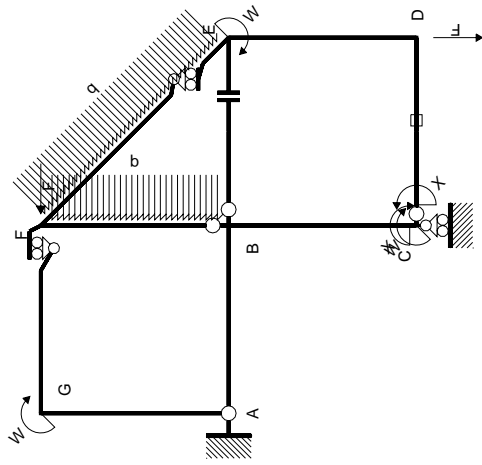

Schema di calcolo iperstatico

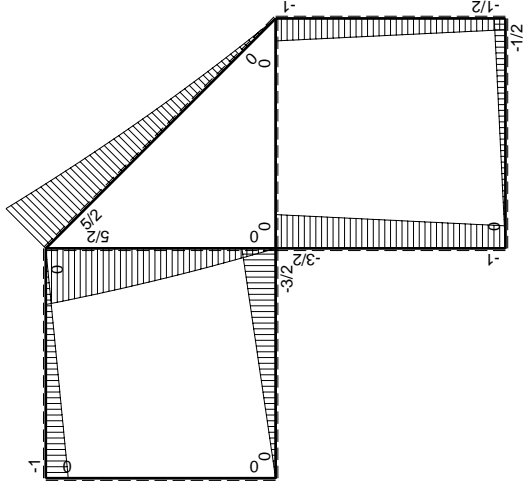

M_0 flessione da carichi assegnati

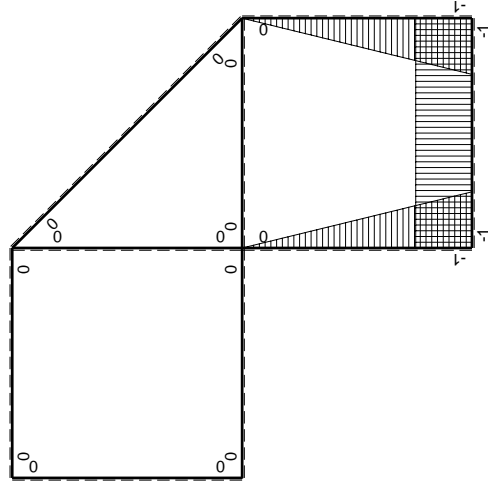

M_x flessione da iperstatica $X=1$

Quadro contribuiti PLV per iperstatica $X=W_{cd}$

\rightarrow	$M_x(x)$	$M_0(x)$	$M_x M_0$	$M_x M_x$	$\int M_x M_0 / EJ dx$	$\int X M_x M_x / EJ dx$
AB b	0	$-3/2Fx$	0	0	0	0
BA b	0	$3/2Fb-3/2Fx$	0	0	0	0
BC b	$-x/b$	$-3/2Fb+1/2Fx$	$3/2Fx-1/2Fx^2/b$	x^2/b^2	$7/12Fb^2/EJ$	$1/3Xb/EJ$
CB b	$1-x/b$	$Fb+1/2Fx$	$Fb-1/2Fx+1/2Fx^2/b$	$1-2x/b+x^2/b^2$	$1/4Fb^2/EJ$	Xb/EJ
CD b	-1	$-1/2Fx$	$1/2Fx$	1	$1/4Fb^2/EJ$	Xb/EJ
DC b	1	$1/2Fb-1/2Fx$	$1/2Fb-1/2Fx$	1	$1/4Fb^2/EJ$	Xb/EJ
DE b	$-1+x/b$	$-1/2Fb-1/2Fx$	$1/2Fb-1/2Fx^2/b$	$1-2x/b+x^2/b^2$	$1/3Fb^2/EJ$	$1/3Xb/EJ$
ED b	x/b	$Fb-1/2Fx$	$Fx-1/2Fx^2/b$	x^2/b^2	0	0
EF $\sqrt{2}b$	0	$3\sqrt{2}4Fx+1/2qx^2$	0	0	0	0
FG b	0	-Fx	0	0	0	0
GF b	0	$Fb-Fx$	0	0	0	0
GA b	0	0	0	0	0	0
AG b	0	0	0	0	0	0
FB b	0	$5/2Fb-2Fx-1/2qx^2$	0	0	0	0
BF b	0	$-3Fx+1/2qx^2$	0	0	0	0
BE b	0	0	0	0	0	0
EB b	0	0	0	0	0	0
CD	elongazione asta $N_{1,cd} \epsilon_{cd} L_{cd}$			0	$-Fb^2/EJ$	
	totali				$1/6Fb^2/EJ$	$5/3Xb/EJ$
	iperstatica $X=W_{cd}$				$-1/10Fb$	

Sviluppi di calcolo iperstatica

$$L_{BC}^{xx} = \int_0^b (x^2/b^2) 1/EJ dx = [1/3 x^3/b^2]_0^b 1/EJ$$

$$= (1/3 b) 1/EJ = 1/3 b/EJ$$

$$L_{CB}^{xx} = \int_0^b (1 - 2x/b + x^2/b^2) 1/EJ dx = [x - x^2/b + 1/3 x^3/b^2]_0^b 1/EJ$$

$$= (b - b + 1/3 b) 1/EJ = 1/3 b/EJ$$

$$L_{CD}^{xx} = \int_0^b (1) 1/EJ dx = [x]_0^b 1/EJ$$

$$= (b) 1/EJ = b/EJ$$

$$L_{DC}^{xx} = \int_0^b (1) 1/EJ dx = [x]_0^b 1/EJ$$

$$= (b) 1/EJ = b/EJ$$

$$L_{DE}^{xx} = \int_0^b (1 - 2x/b + x^2/b^2) 1/EJ dx = [x - x^2/b + 1/3 x^3/b^2]_0^b 1/EJ$$

$$= (b - b + 1/3 b) 1/EJ = 1/3 b/EJ$$

$$L_{ED}^{xx} = \int_0^b (x^2/b^2) 1/EJ dx = [1/3 x^3/b^2]_0^b 1/EJ$$

$$= (1/3 b) 1/EJ = 1/3 b/EJ$$

$$L_{BC}^{xo} = \int_0^b (3/2 x/b - 1/2 x^2/b^2) Fb 1/EJ dx = [3/4 x^2/b - 1/6 x^3/b^2]_0^b Fb 1/EJ$$

$$= (3/4 b - 1/6 b) Fb 1/EJ = 7/12 Fb^2/EJ$$

$$L_{CB}^{xo} = \int_0^b (1 - 1/2 x/b - 1/2 x^2/b^2) Fb 1/EJ dx = [x - 1/4 x^2/b - 1/6 x^3/b^2]_0^b Fb 1/EJ$$

$$= (b - 1/4 b - 1/6 b) Fb 1/EJ = 7/12 Fb^2/EJ$$

$$L_{CD}^{xo} = \int_0^b (1/2 x/b) Fb 1/EJ dx + 1 (-1) 1 Fb^2/EJ = [1/4 x^2/b]_0^b Fb 1/EJ + 1 (-1) 1 Fb^2/EJ$$

$$= (1/4 b) Fb 1/EJ + 1 (-1) 1 Fb^2/EJ = -3/4 Fb^2/EJ$$

$$L_{DC}^{xo} = \int_0^b (1/2 - 1/2 x/b) Fb 1/EJ dx + 1 (-1) 1 Fb^2/EJ = [1/2 x - 1/4 x^2/b]_0^b Fb 1/EJ + 1 (-1) 1 Fb^2/EJ$$

$$= (1/2 b - 1/4 b) Fb 1/EJ + 1 (-1) 1 Fb^2/EJ = -3/4 Fb^2/EJ$$

$$L_{DE}^{xo} = \int_0^b (1/2 - 1/2 x^2/b^2) Fb 1/EJ dx = [1/2 x - 1/6 x^3/b^2]_0^b Fb 1/EJ$$

$$= (1/2 b - 1/6 b) Fb 1/EJ = 1/3 Fb^2/EJ$$

$$L_{ED}^{xo} = \int_0^b (x/b - 1/2 x^2/b^2) Fb 1/EJ dx = [1/2 x^2/b - 1/6 x^3/b^2]_0^b Fb 1/EJ$$

$$= (1/2 b - 1/6 b) Fb 1/EJ = 1/3 Fb^2/EJ$$

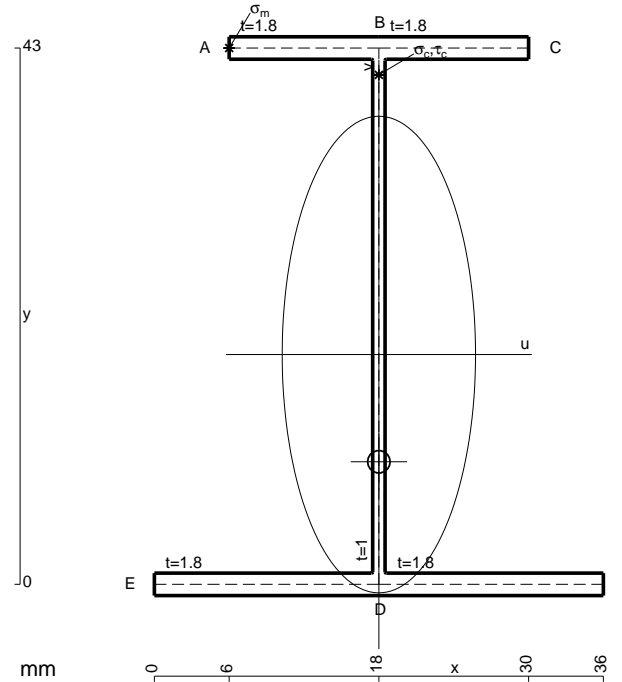

- A = 151. mm²
- J_u = 55120. mm⁴
- J_v = 9072. mm⁴
- J_i = 131. mm⁴
- y_o = -8.596 mm
- y_g = 18.42 mm
- N = 403.1 N
- T_y = 940.5 N
- M_x = 541500. Nmm
- x_m = 6. mm
- y_m = 43. mm
- u_m = -12. mm
- v_m = 24.58 mm
- σ_m = N/A - Mv/J_u = -238.8 N/mm²
- x_c = 18. mm
- y_c = 43. mm
- v_c = 24.58 mm
- σ_c = N/A - Mv/J_u = -238.8 N/mm²
- τ_c = TS/tJ_u = 18.11 N/mm²
- τ_g = TS/tJ_u = 18.11 N/mm²
- t_c = 380. mm
- σ_o = √σ² + 3τ² = 240.8 N/mm²

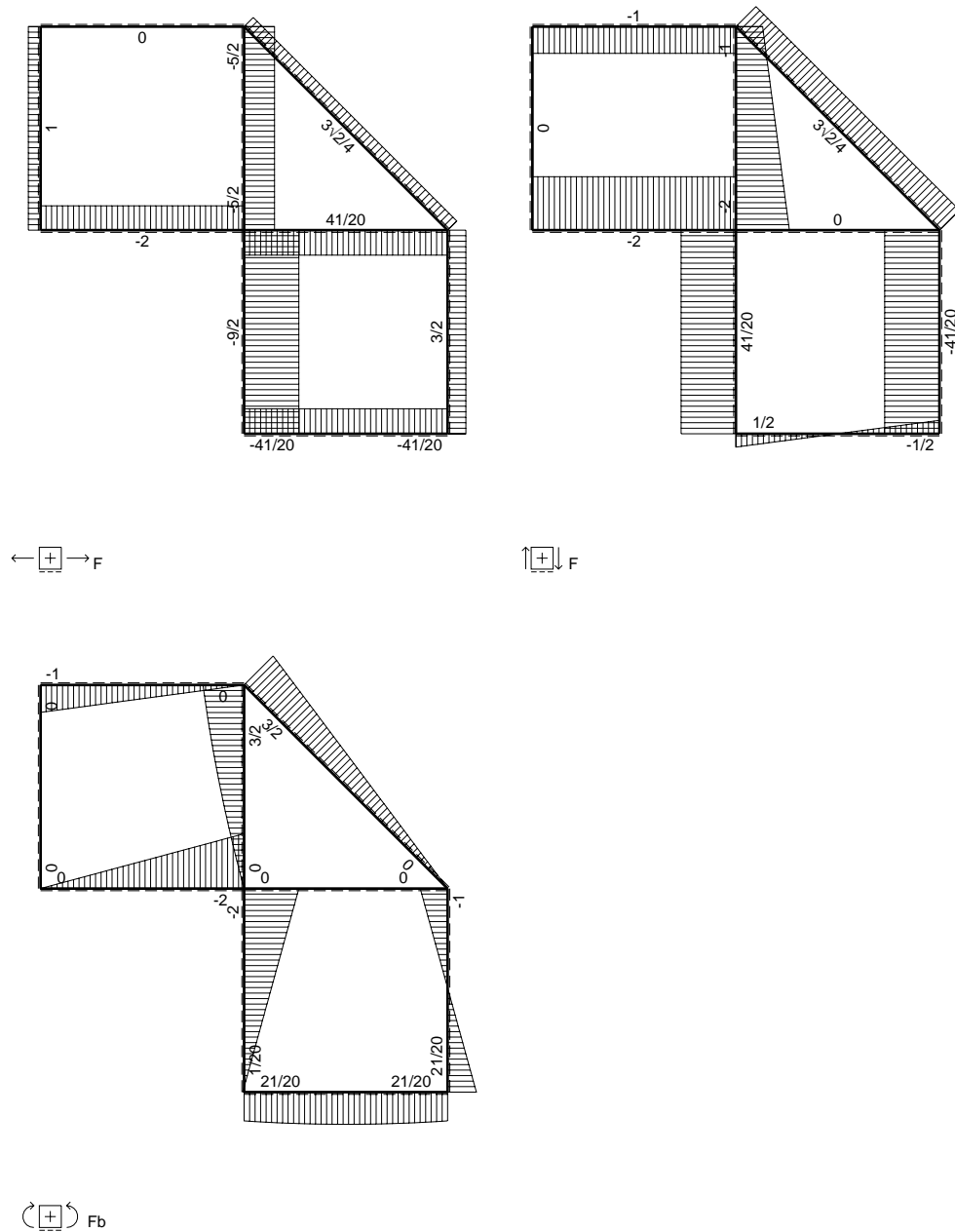
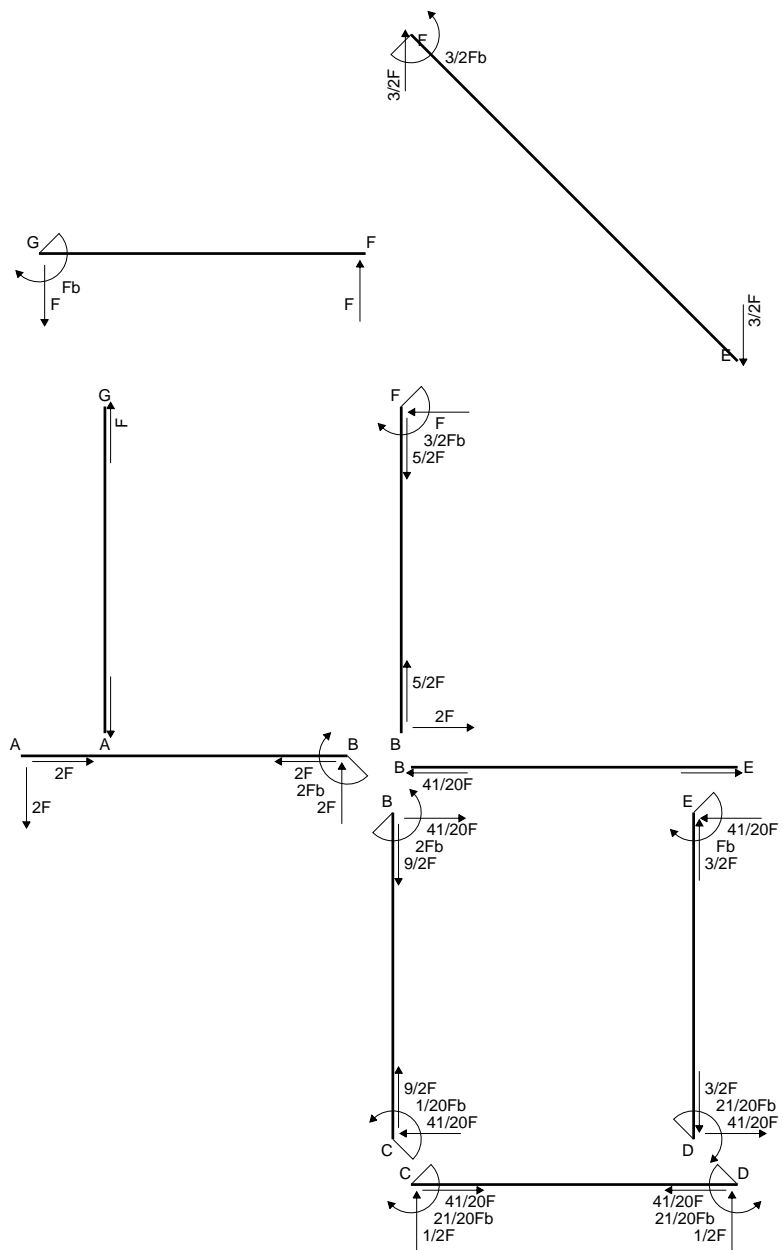

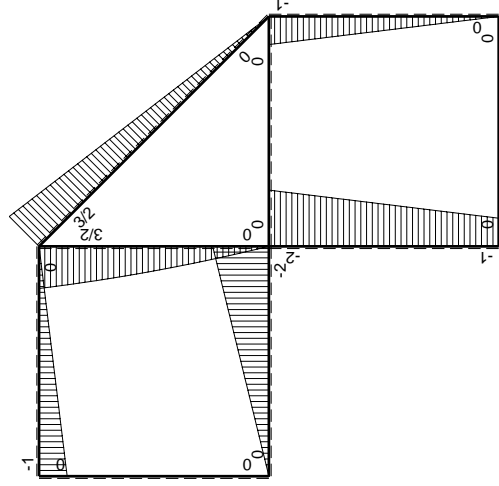
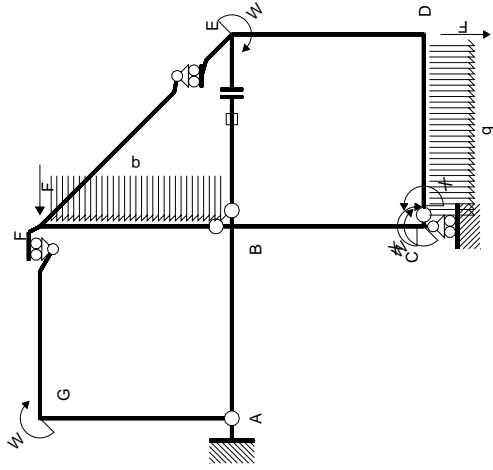

Schema di calcolo iperstatico

M_0 flessione da carichi assegnati

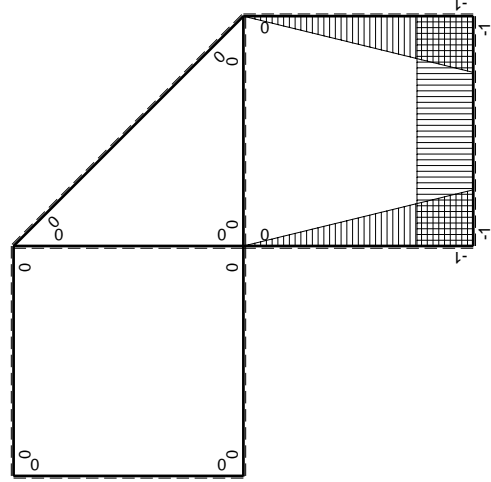

M_x flessione da iperstatica $X=1$

Quadro contribuiti PLV per iperstatica $X=W_{cd}$

\rightarrow	$M_x(x)$	$M_0(x)$	$M_x M_0$	$M_x M_x$	$\int M_x M_0 / EJ dx$	$\int X M_x M_x / EJ dx$
AB b	0	-2Fx	0	0	0	0
BA b	0	2Fb-2Fx	0	0	0	0
BC b	-x/lb	-2Fb+Fx	2Fx-Fx ² /b	x ² /b ²	2/3Fb ² /EJ	1/3Xb/EJ
CB b	1-x/lb	Fb+Fx	Fb-Fx ² /b	1-2x/b+x ² /b ²	2/3Fb ² /EJ	1/3Xb/EJ
CD b	-1	1/2Fx-1/2qx ²	-1/2Fx+1/2Fx ² /b	1	-1/12Fb ² /EJ	Xb/EJ
DC b	1	-1/2Fx+1/2qx ²	-1/2Fx+1/2Fx ² /b	1	-1/12Fb ² /EJ	Xb/EJ
DE b	-1+x/lb	-Fx	Fx-Fx ² /b	1-2x/b+x ² /b ²	1/6Fb ² /EJ	1/3Xb/EJ
ED b	x/lb	Fb-Fx	Fx-Fx ² /b	x ² /b ²	1/6Fb ² /EJ	1/3Xb/EJ
EF $\sqrt{2}b$	0	3 $\sqrt{2}$ /4Fx	0	0	0	0
FG b	0	-Fx	0	0	0	0
GF b	0	Fb-Fx	0	0	0	0
GA b	0	0	0	0	0	0
AG b	0	0	0	0	0	0
FB b	0	3/2Fb-Fx-1/2qx ²	0	0	0	0
BF b	0	-2Fx+1/2qx ²	0	0	0	0
BE b	0	0	0	0	0	0
EB b	0	0	0	0	0	0
BE	elongazione asta $N_{1, BE}^{\epsilon} = L_{BE}$				Fb ² /EJ	
totali					7/4Fb ² /EJ	5/3Xb/EJ
iperstatica $X=W_{cd}$					-21/20Fb	

Sviluppi di calcolo iperstatica

$$L_{BC}^{xx} = \int_0^b (x^2/b^2) 1/EJ dx = [1/3 x^3/b^2]_0^b 1/EJ$$

$$= (1/3 b) 1/EJ = 1/3 b/EJ$$

$$L_{CB}^{xx} = \int_0^b (1 - 2x/b + x^2/b^2) 1/EJ dx = [x - x^2/b + 1/3 x^3/b^2]_0^b 1/EJ$$

$$= (b - b + 1/3 b) 1/EJ = 1/3 b/EJ$$

$$L_{CD}^{xx} = \int_0^b (1) 1/EJ dx = [x]_0^b 1/EJ$$

$$= (b) 1/EJ = b/EJ$$

$$L_{DC}^{xx} = \int_0^b (1) 1/EJ dx = [x]_0^b 1/EJ$$

$$= (b) 1/EJ = b/EJ$$

$$L_{DE}^{xx} = \int_0^b (1 - 2x/b + x^2/b^2) 1/EJ dx = [x - x^2/b + 1/3 x^3/b^2]_0^b 1/EJ$$

$$= (b - b + 1/3 b) 1/EJ = 1/3 b/EJ$$

$$L_{ED}^{xx} = \int_0^b (x^2/b^2) 1/EJ dx = [1/3 x^3/b^2]_0^b 1/EJ$$

$$= (1/3 b) 1/EJ = 1/3 b/EJ$$

$$L_{BC}^{xo} = \int_0^b (2x/b - x^2/b^2) Fb 1/EJ dx = [x^2/b - 1/3 x^3/b^2]_0^b Fb 1/EJ$$

$$= (b - 1/3 b) Fb 1/EJ = 2/3 Fb^2/EJ$$

$$L_{CB}^{xo} = \int_0^b (1 - x^2/b^2) Fb 1/EJ dx = [x - 1/3 x^3/b^2]_0^b Fb 1/EJ$$

$$= (b - 1/3 b) Fb 1/EJ = 2/3 Fb^2/EJ$$

$$L_{CD}^{xo} = \int_0^b (-1/2 x/b + 1/2 x^2/b^2) Fb 1/EJ dx = [-1/4 x^2/b + 1/6 x^3/b^2]_0^b Fb 1/EJ$$

$$= (-1/4 b + 1/6 b) Fb 1/EJ = -1/12 Fb^2/EJ$$

$$L_{DC}^{xo} = \int_0^b (-1/2 x/b + 1/2 x^2/b^2) Fb 1/EJ dx = [-1/4 x^2/b + 1/6 x^3/b^2]_0^b Fb 1/EJ$$

$$= (-1/4 b + 1/6 b) Fb 1/EJ = -1/12 Fb^2/EJ$$

$$L_{DE}^{xo} = \int_0^b (x/b - x^2/b^2) Fb 1/EJ dx = [1/2 x^2/b - 1/3 x^3/b^2]_0^b Fb 1/EJ$$

$$= (1/2 b - 1/3 b) Fb 1/EJ = 1/6 Fb^2/EJ$$

$$L_{ED}^{xo} = \int_0^b (x/b - x^2/b^2) Fb 1/EJ dx = [1/2 x^2/b - 1/3 x^3/b^2]_0^b Fb 1/EJ$$

$$= (1/2 b - 1/3 b) Fb 1/EJ = 1/6 Fb^2/EJ$$

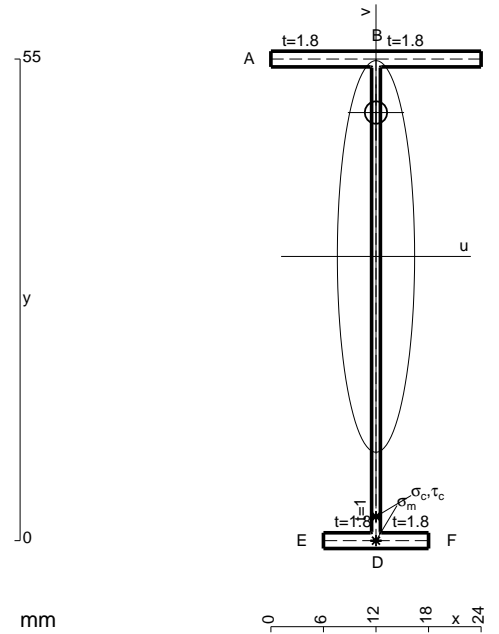

$$A = 119.8 \text{ mm}^2$$

$$J_u = 59924. \text{ mm}^4$$

$$J_v = 2333. \text{ mm}^4$$

$$J_t = 88.32 \text{ mm}^4$$

$$y_o = 16.43 \text{ mm}$$

$$y_g = 32.46 \text{ mm}$$

$$N = -460. \text{ N}$$

$$T_y = -460. \text{ N}$$

$$M_x = -358800. \text{ Nmm}$$

$$x_m = 12. \text{ mm}$$

$$v_m = -32.46 \text{ mm}$$

$$\sigma_m = N/A - Mv/J_u = -198.2 \text{ N/mm}^2$$

$$y_c = 3. \text{ mm}$$

$$u_c = -12. \text{ mm}$$

$$v_c = -29.46 \text{ mm}$$

$$\sigma_c = N/A - Mv/J_u = -198.2 \text{ N/mm}^2$$

$$\tau_c = TS'/tJ_u = 5.382 \text{ N/mm}^2$$

$$\tau_g = TS'/tJ_u = 5.382 \text{ N/mm}^2$$

$$t_c = 230. \text{ mm}$$

$$\sigma_o = \sqrt{\sigma^2 + 3\tau^2} = 198.4 \text{ N/mm}^2$$

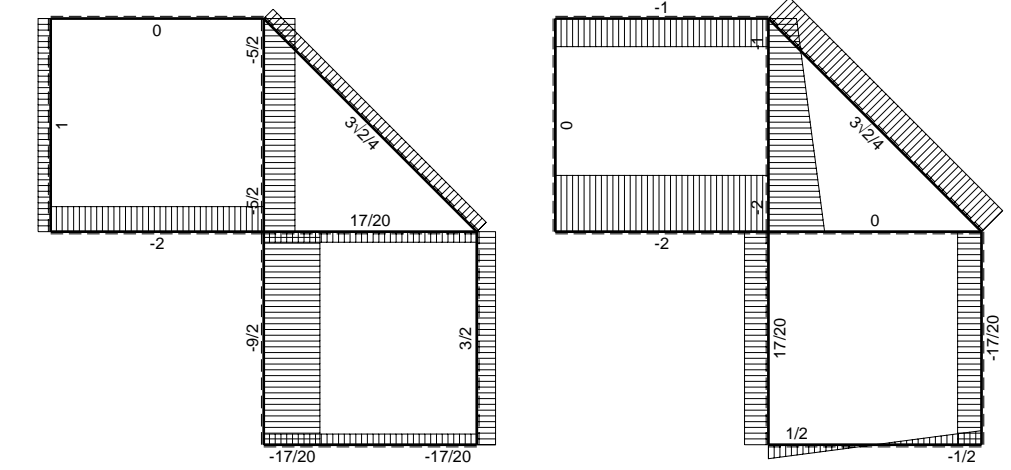
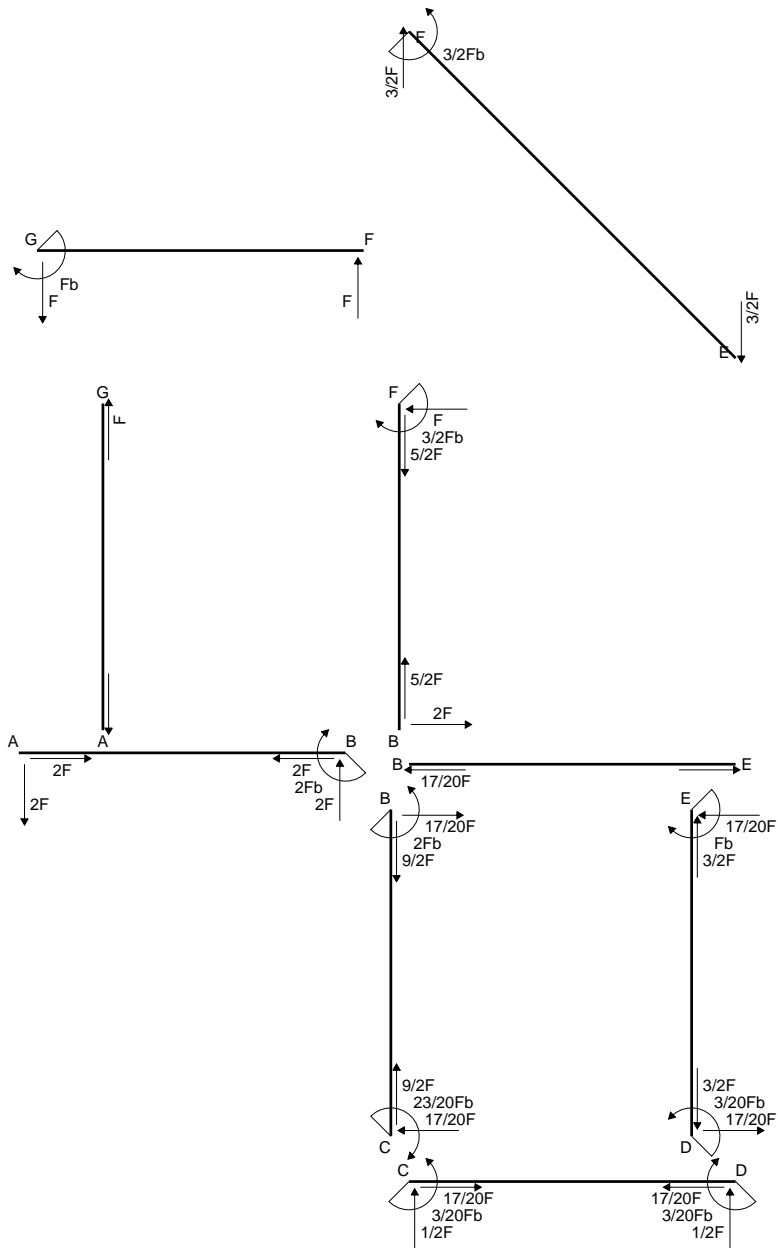

← ⊕ → F

↑ ⊕ ↓ F

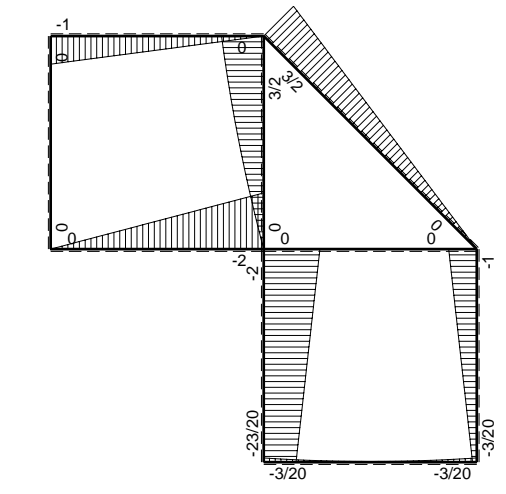

⊕ ⊖ Fb

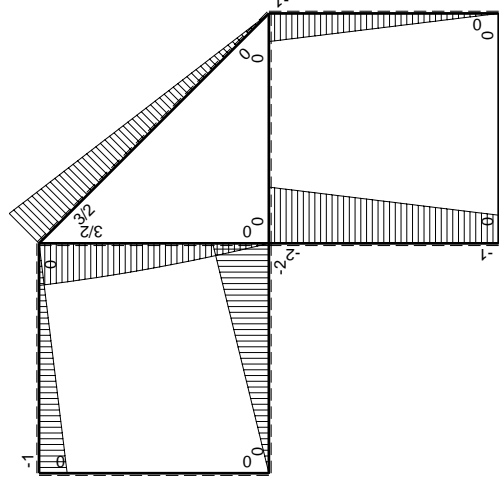
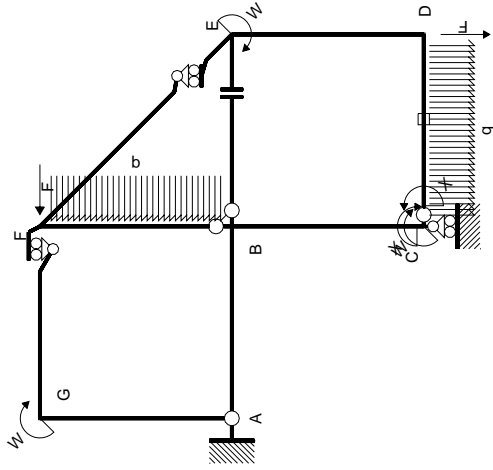

Schema di calcolo iperstatico

M_0 flessione da carichi assegnati

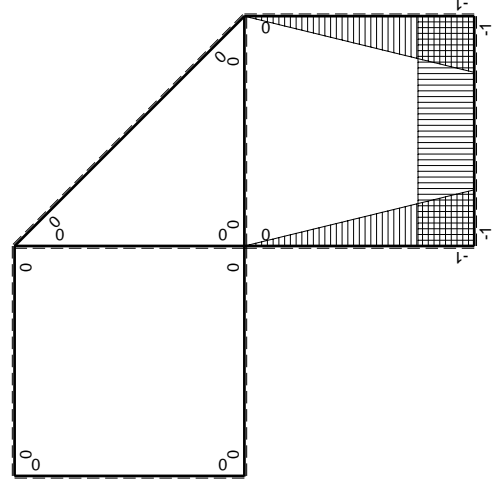

M_x flessione da iperstatica $X=1$

Quadro contribuiti PLV per iperstatica $X=W_{cd}$

\rightarrow	$M_x(x)$	$M_0(x)$	$M_x M_0$	$M_x M_x$	$\int M_x M_0 / EJ dx$	$\int X M_x M_x / EJ dx$
AB b	0	-2Fx	0	0	0	0
BA b	0	2Fb-2Fx	0	0	0	0
BC b	-x/b	-2Fb+Fx	2Fx-Fx ² /b	x ² /b ²	2/3Fb ² /EJ	1/3Xb/EJ
CB b	1-x/b	Fb+Fx	Fb-Fx ² /b	1-2x/b+x ² /b ²	2/3Fb ² /EJ	1/3Xb/EJ
CD b	-1	1/2Fx-1/2qx ²	-1/2Fx+1/2Fx ² /b	1	-1/12Fb ² /EJ	Xb/EJ
DC b	1	-1/2Fx+1/2qx ²	-1/2Fx+1/2Fx ² /b	1	-1/12Fb ² /EJ	Xb/EJ
DE b	-1+x/b	-Fx	Fx-Fx ² /b	1-2x/b+x ² /b ²	1/6Fb ² /EJ	1/3Xb/EJ
ED b	x/b	Fb-Fx	Fx-Fx ² /b	x ² /b ²	1/6Fb ² /EJ	1/3Xb/EJ
EF $\sqrt{2}b$	0	3 $\sqrt{2}$ /4Fx	0	0	0	0
FG b	0	-Fx	0	0	0	0
GF b	0	Fb-Fx	0	0	0	0
GA b	0	0	0	0	0	0
AG b	0	0	0	0	0	0
FB b	0	3/2Fb-Fx-1/2qx ²	0	0	0	0
BF b	0	-2Fx+1/2qx ²	0	0	0	0
BE b	0	0	0	0	0	0
EB b	0	0	0	0	0	0
CD	elongazione asta $N_{1,cd} \epsilon_{cd} L_{cd}$			0	-Fb ² /EJ	
	totali				-1/4Fb ² /EJ	5/3Xb/EJ
	iperstatica $X=W_{cd}$				3/20Fb	

Sviluppi di calcolo iperstatica

$$L_{BC}^{xx} = \int_0^b (x^2/b^2) 1/EJ dx = [1/3 x^3/b^2]_0^b 1/EJ$$

$$= (1/3 b) 1/EJ = 1/3 b/EJ$$

$$L_{CB}^{xx} = \int_0^b (1 - 2x/b + x^2/b^2) 1/EJ dx = [x - x^2/b + 1/3 x^3/b^2]_0^b 1/EJ$$

$$= (b - b + 1/3 b) 1/EJ = 1/3 b/EJ$$

$$L_{CD}^{xx} = \int_0^b (1) 1/EJ dx = [x]_0^b 1/EJ$$

$$= (b) 1/EJ = b/EJ$$

$$L_{DC}^{xx} = \int_0^b (1) 1/EJ dx = [x]_0^b 1/EJ$$

$$= (b) 1/EJ = b/EJ$$

$$L_{DE}^{xx} = \int_0^b (1 - 2x/b + x^2/b^2) 1/EJ dx = [x - x^2/b + 1/3 x^3/b^2]_0^b 1/EJ$$

$$= (b - b + 1/3 b) 1/EJ = 1/3 b/EJ$$

$$L_{ED}^{xx} = \int_0^b (x^2/b^2) 1/EJ dx = [1/3 x^3/b^2]_0^b 1/EJ$$

$$= (1/3 b) 1/EJ = 1/3 b/EJ$$

$$L_{BC}^{xo} = \int_0^b (2x/b - x^2/b^2) Fb 1/EJ dx = [x^2/b - 1/3 x^3/b^2]_0^b Fb 1/EJ$$

$$= (b - 1/3 b) Fb 1/EJ = 2/3 Fb^2/EJ$$

$$L_{CB}^{xo} = \int_0^b (1 - x^2/b^2) Fb 1/EJ dx = [x - 1/3 x^3/b^2]_0^b Fb 1/EJ$$

$$= (b - 1/3 b) Fb 1/EJ = 2/3 Fb^2/EJ$$

$$L_{CD}^{xo} = \int_0^b (-1/2 x/b + 1/2 x^2/b^2) Fb 1/EJ dx + 1 (-1) 1 Fb^2/EJ$$

$$= [-1/4 x^2/b + 1/6 x^3/b^2]_0^b Fb 1/EJ + 1 (-1) 1 Fb^2/EJ$$

$$= (-1/4 b + 1/6 b) Fb 1/EJ + 1 (-1) 1 Fb^2/EJ = -13/12 Fb^2/EJ$$

$$L_{DC}^{xo} = \int_0^b (-1/2 x/b + 1/2 x^2/b^2) Fb 1/EJ dx + 1 (-1) 1 Fb^2/EJ$$

$$= [-1/4 x^2/b + 1/6 x^3/b^2]_0^b Fb 1/EJ + 1 (-1) 1 Fb^2/EJ$$

$$= (-1/4 b + 1/6 b) Fb 1/EJ + 1 (-1) 1 Fb^2/EJ = -13/12 Fb^2/EJ$$

$$L_{DE}^{xo} = \int_0^b (x/b - x^2/b^2) Fb 1/EJ dx = [1/2 x^2/b - 1/3 x^3/b^2]_0^b Fb 1/EJ$$

$$= (1/2 b - 1/3 b) Fb 1/EJ = 1/6 Fb^2/EJ$$

$$L_{ED}^{xo} = \int_0^b (x/b - x^2/b^2) Fb 1/EJ dx = [1/2 x^2/b - 1/3 x^3/b^2]_0^b Fb 1/EJ$$

$$= (1/2 b - 1/3 b) Fb 1/EJ = 1/6 Fb^2/EJ$$

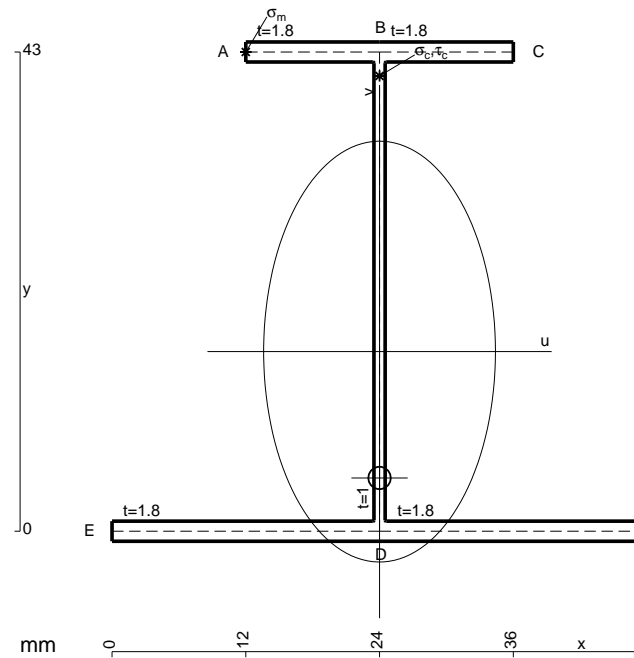

- A = 172.6 mm²
- J_u = 61535. mm⁴
- J_v = 18662. mm⁴
- J_t = 154.3 mm⁴
- y_o = -11.34 mm
- y_g = 16.12 mm
- N = -740. N
- T_y = -740. N
- M_x = -481000. Nmm
- x_m = 12. mm
- y_m = 43. mm
- u_m = -12. mm
- v_m = 26.88 mm
- σ_m = N/A-Mv/J_u = 205.8 N/mm²
- x_c = 24. mm
- y_c = 43. mm
- v_c = 26.88 mm
- σ_c = N/A-Mv/J_u = 205.8 N/mm²
- τ_c = TS'/tJ_u = 13.97 N/mm²
- τ_g = TS'/tJ_u = 13.97 N/mm²
- t_c = 370. mm
- σ_o = √σ²+3τ² = 207.3 N/mm²

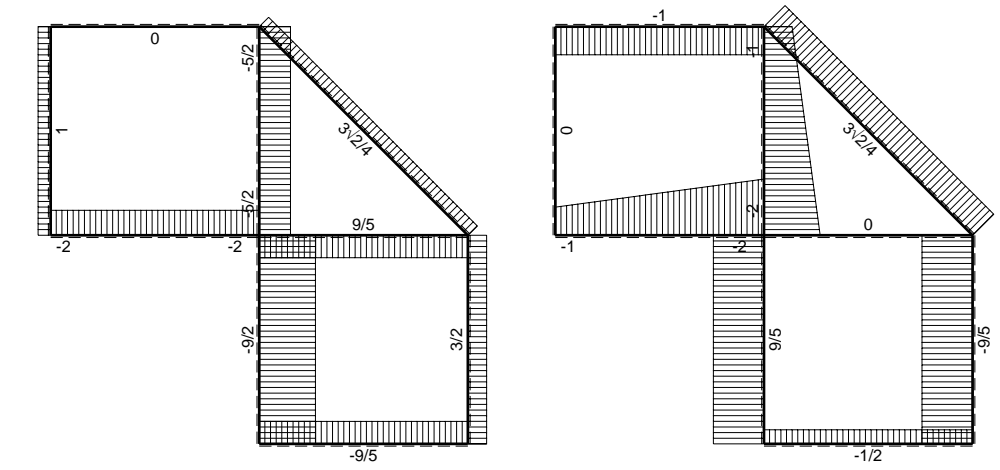
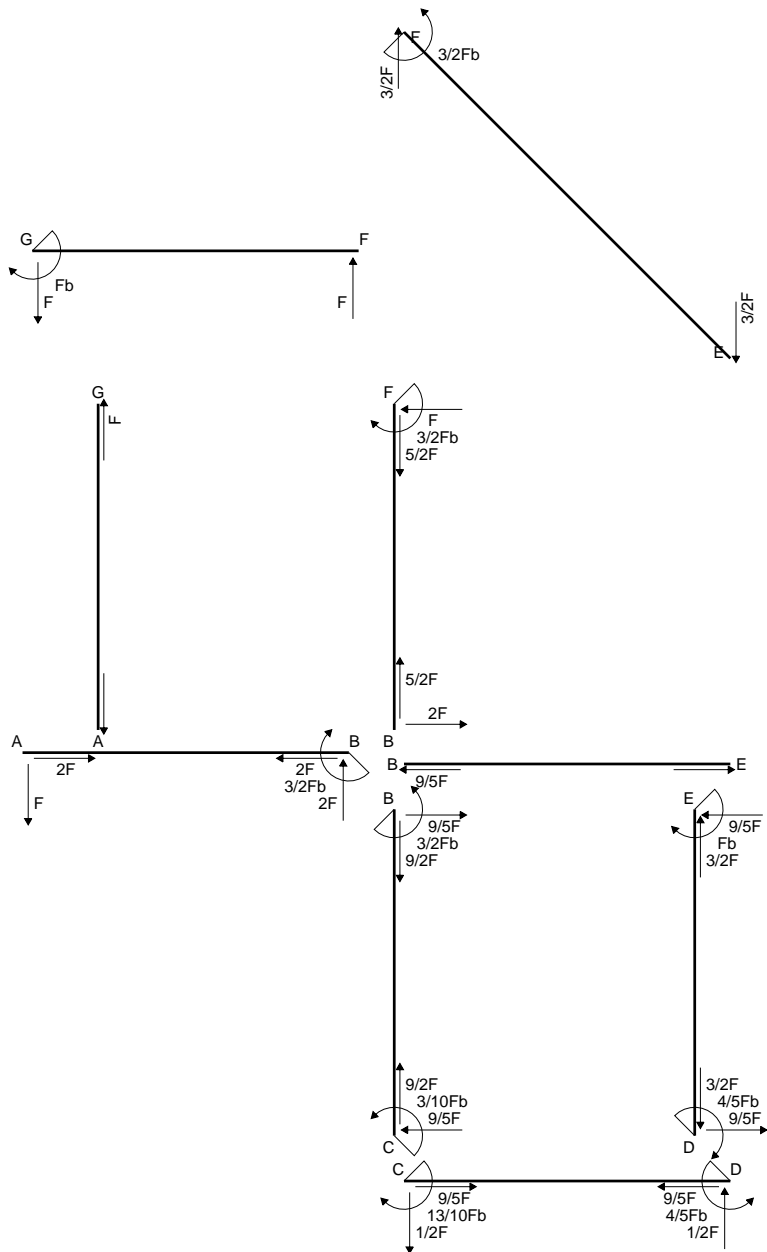

← ⊕ → F

↑ ⊕ ↓ F

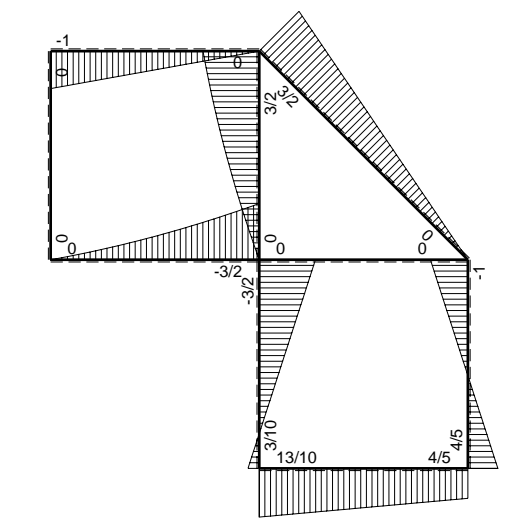

⊕ ⊖ F_b

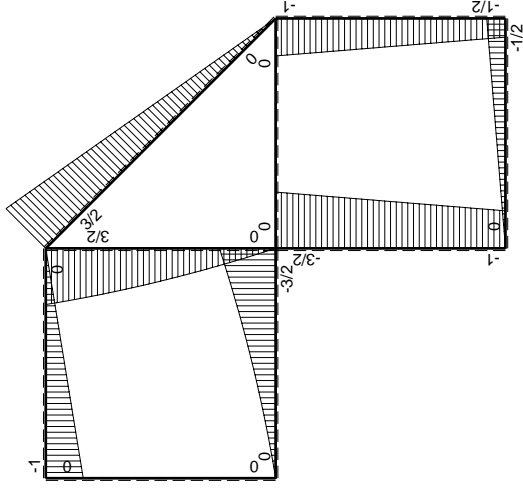
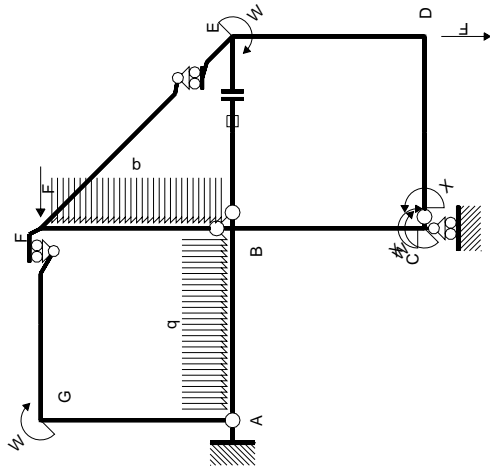

Schema di calcolo iperstatico

M_0 flessione da carichi assegnati

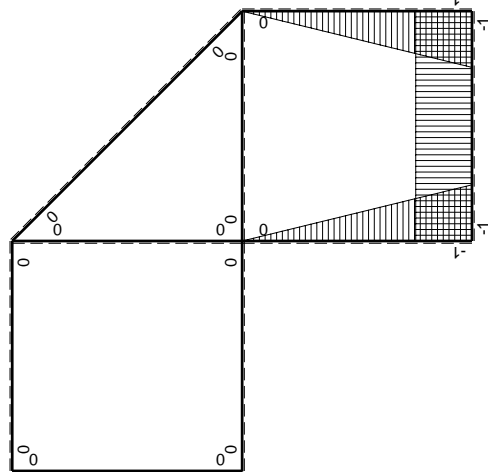

M_x flessione da iperstatica $X=1$

Quadro contribuiti PLV per iperstatica $X=W_{cd}$

\rightarrow	$M_x(x)$	$M_0(x)$	$M_x M_0$	$M_x M_x$	$\int M_x M_0 / E J dx$	$\int X M_x M_x / E J dx$
AB b	0	$-Fx - 1/2qx^2$	0	0	0	0
BA b	0	$3/2Fb - 2Fx + 1/2qx^2$	0	0	0	0
BC b	$-x/b$	$-3/2Fb + 1/2Fx$	$3/2Fx - 1/2Fx^2/b$	x^2/b^2	$7/12Fb^2/EJ$	$1/3Xb/EJ$
CB b	$1-x/b$	$Fb + 1/2Fx$	$Fb - 1/2Fx - 1/2Fx^2/b$	$1 - 2x/b + x^2/b^2$	$1/4Fb^2/EJ$	Xb/EJ
CD b	-1	$-1/2Fx$	$1/2Fx$	1	$1/4Fb^2/EJ$	Xb/EJ
DC b	1	$1/2Fb - 1/2Fx$	$1/2Fb - 1/2Fx$	1	$1/4Fb^2/EJ$	Xb/EJ
DE b	$-1+x/b$	$-1/2Fb - 1/2Fx$	$1/2Fb - 1/2Fx^2/b$	$1 - 2x/b + x^2/b^2$	$1/3Fb^2/EJ$	$1/3Xb/EJ$
ED b	x/b	$Fb - 1/2Fx$	$Fx - 1/2Fx^2/b$	x^2/b^2	$1/3Fb^2/EJ$	$1/3Xb/EJ$
EF $\sqrt{2}b$	0	$3\sqrt{2}/4Fx$	0	0	0	0
FG b	0	$-Fx$	0	0	0	0
GF b	0	$Fb - Fx$	0	0	0	0
GA b	0	0	0	0	0	0
AG b	0	0	0	0	0	0
FB b	0	$3/2Fb - Fx - 1/2qx^2$	0	0	0	0
BF b	0	$-2Fx + 1/2qx^2$	0	0	0	0
BE b	0	0	0	0	0	0
EB b	0	0	0	0	0	0
BE	elongazione asta $N_{1, BE} \epsilon_{BE} L_{BE}$				Fb^2/EJ	
	totali				$13/6Fb^2/EJ$	$5/3Xb/EJ$
	iperstatica $X=W_{cd}$				$-13/10Fb$	

Sviluppi di calcolo iperstatica

$$L_{BC}^{xx} = \int_0^b (x^2/b^2) 1/EJ dx = [1/3 x^3/b^2]_0^b 1/EJ$$

$$= (1/3 b) 1/EJ = 1/3 b/EJ$$

$$L_{CB}^{xx} = \int_0^b (1 - 2x/b + x^2/b^2) 1/EJ dx = [x - x^2/b + 1/3 x^3/b^2]_0^b 1/EJ$$

$$= (b - b + 1/3 b) 1/EJ = 1/3 b/EJ$$

$$L_{CD}^{xx} = \int_0^b (1) 1/EJ dx = [x]_0^b 1/EJ$$

$$= (b) 1/EJ = b/EJ$$

$$L_{DC}^{xx} = \int_0^b (1) 1/EJ dx = [x]_0^b 1/EJ$$

$$= (b) 1/EJ = b/EJ$$

$$L_{DE}^{xx} = \int_0^b (1 - 2x/b + x^2/b^2) 1/EJ dx = [x - x^2/b + 1/3 x^3/b^2]_0^b 1/EJ$$

$$= (b - b + 1/3 b) 1/EJ = 1/3 b/EJ$$

$$L_{ED}^{xx} = \int_0^b (x^2/b^2) 1/EJ dx = [1/3 x^3/b^2]_0^b 1/EJ$$

$$= (1/3 b) 1/EJ = 1/3 b/EJ$$

$$L_{BC}^{xo} = \int_0^b (3/2 x/b - 1/2 x^2/b^2) Fb 1/EJ dx = [3/4 x^2/b - 1/6 x^3/b^2]_0^b Fb 1/EJ$$

$$= (3/4 b - 1/6 b) Fb 1/EJ = 7/12 Fb^2/EJ$$

$$L_{CB}^{xo} = \int_0^b (1 - 1/2 x/b - 1/2 x^2/b^2) Fb 1/EJ dx = [x - 1/4 x^2/b - 1/6 x^3/b^2]_0^b Fb 1/EJ$$

$$= (b - 1/4 b - 1/6 b) Fb 1/EJ = 7/12 Fb^2/EJ$$

$$L_{CD}^{xo} = \int_0^b (1/2 x/b) Fb 1/EJ dx = [1/4 x^2/b]_0^b Fb 1/EJ$$

$$= (1/4 b) Fb 1/EJ = 1/4 Fb^2/EJ$$

$$L_{DC}^{xo} = \int_0^b (1/2 - 1/2 x/b) Fb 1/EJ dx = [1/2 x - 1/4 x^2/b]_0^b Fb 1/EJ$$

$$= (1/2 b - 1/4 b) Fb 1/EJ = 1/4 Fb^2/EJ$$

$$L_{DE}^{xo} = \int_0^b (1/2 - 1/2 x^2/b^2) Fb 1/EJ dx = [1/2 x - 1/6 x^3/b^2]_0^b Fb 1/EJ$$

$$= (1/2 b - 1/6 b) Fb 1/EJ = 1/3 Fb^2/EJ$$

$$L_{ED}^{xo} = \int_0^b (x/b - 1/2 x^2/b^2) Fb 1/EJ dx = [1/2 x^2/b - 1/6 x^3/b^2]_0^b Fb 1/EJ$$

$$= (1/2 b - 1/6 b) Fb 1/EJ = 1/3 Fb^2/EJ$$

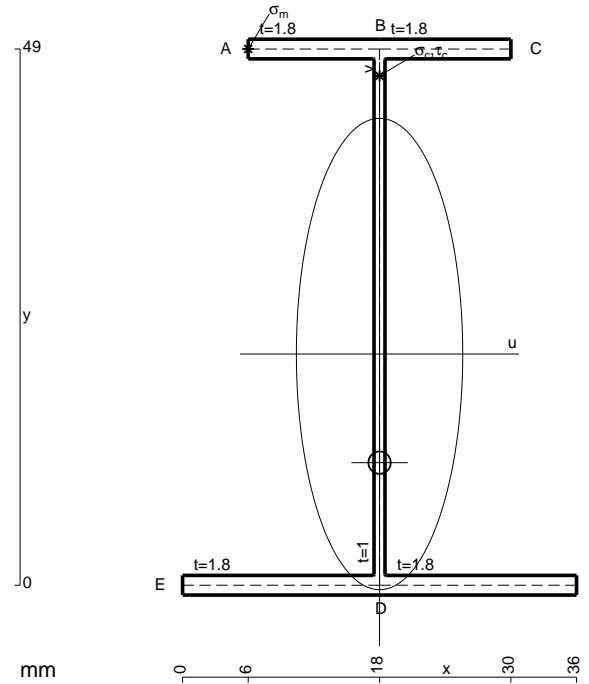

$$A = 157. \text{ mm}^2$$

$$J_u = 72847. \text{ mm}^4$$

$$J_v = 9072. \text{ mm}^4$$

$$J_t = 133. \text{ mm}^4$$

$$y_o = -9.929 \text{ mm}$$

$$y_g = 21.13 \text{ mm}$$

$$N = -1000. \text{ N}$$

$$T_y = -1000. \text{ N}$$

$$M_x = -585000. \text{ Nmm}$$

$$x_m = 6. \text{ mm}$$

$$y_m = 49. \text{ mm}$$

$$u_m = -12. \text{ mm}$$

$$v_m = 27.87 \text{ mm}$$

$$\sigma_m = N/A - Mv/J_u = 217.4 \text{ N/mm}^2$$

$$x_c = 18. \text{ mm}$$

$$y_c = 49. \text{ mm}$$

$$v_c = 27.87 \text{ mm}$$

$$\sigma_c = N/A - Mv/J_u = 217.4 \text{ N/mm}^2$$

$$\tau_c = TS/tJ_u = 16.53 \text{ N/mm}^2$$

$$\tau_g = TS/tJ_u = 16.53 \text{ N/mm}^2$$

$$t_c = 500. \text{ mm}$$

$$\sigma_o = \sqrt{\sigma^2 + 3\tau^2} = 219.3 \text{ N/mm}^2$$

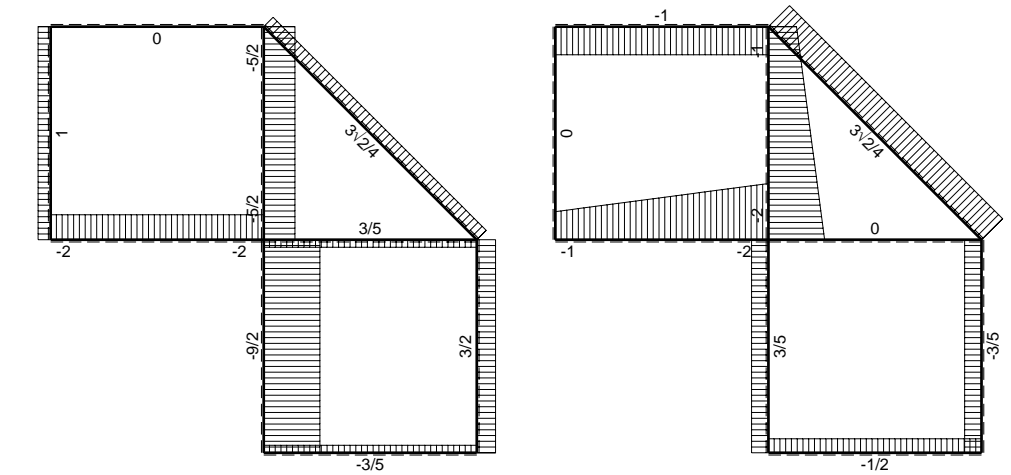
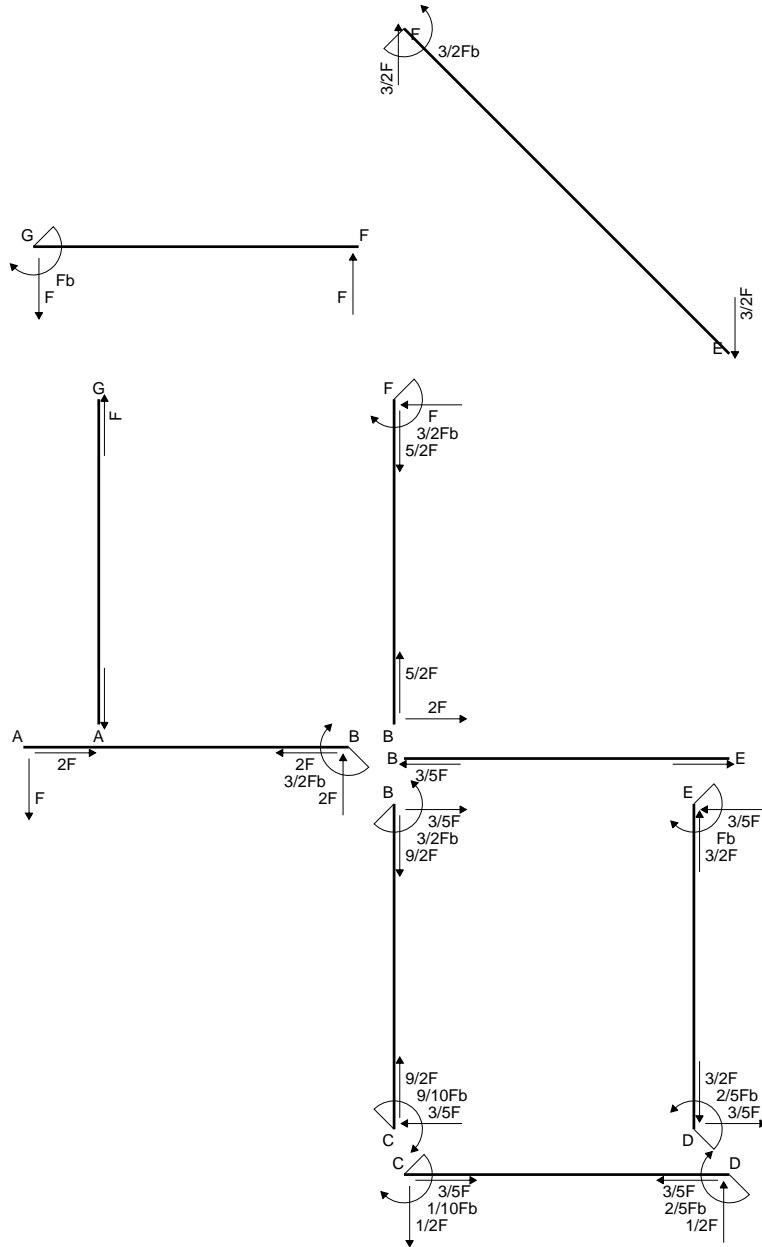

← ⊕ → F

↑ ⊕ ↓ F

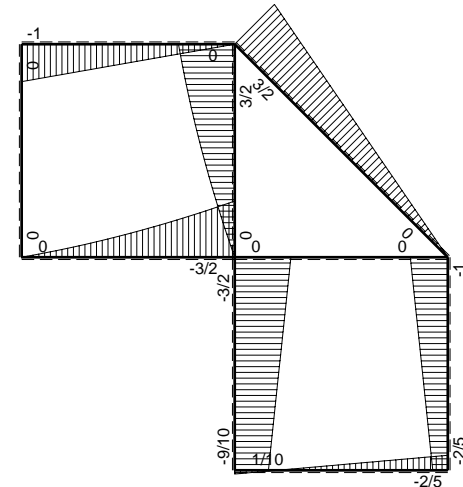

⊕ F_b

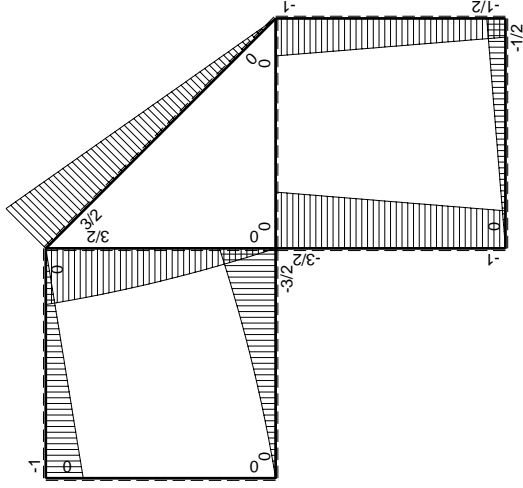
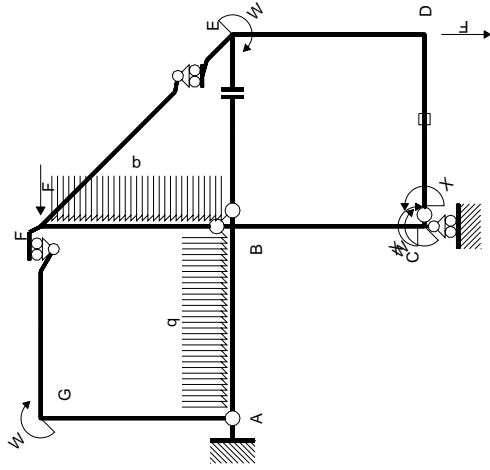

Schema di calcolo iperstatico

M_0 flessione da carichi assegnati

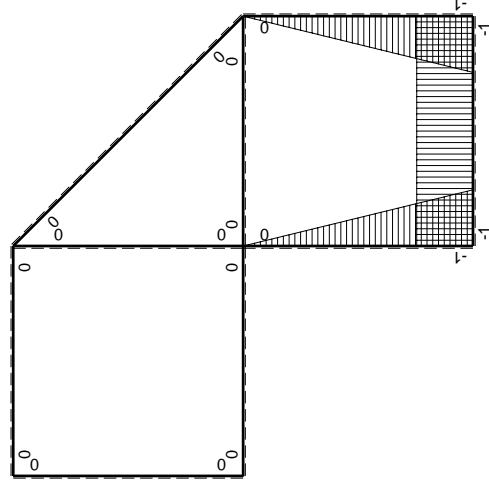

M_x flessione da iperstatica $X=1$

Quadro contribuiti PLV per iperstatica $X=W_{cd}$

\rightarrow	$M_x(x)$	$M_0(x)$	$M_x M_0$	$M_x M_x$	$\int M_x M_0 / EJ dx$	$\int X M_x M_x / EJ dx$
AB b	0	$-Fx - 1/2qx^2$	0	0	0	0
BA b	0	$3/2Fb - 2Fx + 1/2qx^2$	0	0	0	0
BC b	$-x/b$	$-3/2Fb + 1/2Fx$	$3/2Fx - 1/2Fx^2/b$	x^2/b^2	$7/12Fb^2/EJ$	$1/3Xb/EJ$
CB b	$1-x/b$	$Fb + 1/2Fx$	$Fb - 1/2Fx - 1/2Fx^2/b$	$1 - 2x/b + x^2/b^2$	$1/4Fb^2/EJ$	Xb/EJ
CD b	-1	$-1/2Fx$	$1/2Fx$	1	$1/4Fb^2/EJ$	Xb/EJ
DC b	1	$1/2Fb - 1/2Fx$	$1/2Fb - 1/2Fx$	1	$1/4Fb^2/EJ$	Xb/EJ
DE b	$-1+x/b$	$-1/2Fb - 1/2Fx$	$1/2Fb - 1/2Fx^2/b$	$1 - 2x/b + x^2/b^2$	$1/3Fb^2/EJ$	$1/3Xb/EJ$
ED b	x/b	$Fb - 1/2Fx$	$Fx - 1/2Fx^2/b$	x^2/b^2	$1/3Fb^2/EJ$	$1/3Xb/EJ$
EF $\sqrt{2}b$	0	$3\sqrt{2}/4Fx$	0	0	0	0
FG b	0	$-Fx$	0	0	0	0
GF b	0	$Fb - Fx$	0	0	0	0
GA b	0	0	0	0	0	0
AG b	0	0	0	0	0	0
FB b	0	$3/2Fb - Fx - 1/2qx^2$	0	0	0	0
BF b	0	$-2Fx + 1/2qx^2$	0	0	0	0
BE b	0	0	0	0	0	0
EB b	0	0	0	0	0	0
CD	elongazione asta $N_{1,cd} \epsilon_{cd} L_{cd}$				$-Fb^2/EJ$	
	totali				$1/6Fb^2/EJ$	$5/3Xb/EJ$
	iperstatica $X=W_{cd}$				$-1/10Fb$	

Sviluppi di calcolo iperstatica

$$L_{BC}^{xx} = \int_0^b (x^2/b^2) 1/EJ dx = [1/3 x^3/b^2]_0^b 1/EJ$$

$$= (1/3 b) 1/EJ = 1/3 b/EJ$$

$$L_{CB}^{xx} = \int_0^b (1 - 2x/b + x^2/b^2) 1/EJ dx = [x - x^2/b + 1/3 x^3/b^2]_0^b 1/EJ$$

$$= (b - b + 1/3 b) 1/EJ = 1/3 b/EJ$$

$$L_{CD}^{xx} = \int_0^b (1) 1/EJ dx = [x]_0^b 1/EJ$$

$$= (b) 1/EJ = b/EJ$$

$$L_{DC}^{xx} = \int_0^b (1) 1/EJ dx = [x]_0^b 1/EJ$$

$$= (b) 1/EJ = b/EJ$$

$$L_{DE}^{xx} = \int_0^b (1 - 2x/b + x^2/b^2) 1/EJ dx = [x - x^2/b + 1/3 x^3/b^2]_0^b 1/EJ$$

$$= (b - b + 1/3 b) 1/EJ = 1/3 b/EJ$$

$$L_{ED}^{xx} = \int_0^b (x^2/b^2) 1/EJ dx = [1/3 x^3/b^2]_0^b 1/EJ$$

$$= (1/3 b) 1/EJ = 1/3 b/EJ$$

$$L_{BC}^{xo} = \int_0^b (3/2 x/b - 1/2 x^2/b^2) Fb 1/EJ dx = [3/4 x^2/b - 1/6 x^3/b^2]_0^b Fb 1/EJ$$

$$= (3/4 b - 1/6 b) Fb 1/EJ = 7/12 Fb^2/EJ$$

$$L_{CB}^{xo} = \int_0^b (1 - 1/2 x/b - 1/2 x^2/b^2) Fb 1/EJ dx = [x - 1/4 x^2/b - 1/6 x^3/b^2]_0^b Fb 1/EJ$$

$$= (b - 1/4 b - 1/6 b) Fb 1/EJ = 7/12 Fb^2/EJ$$

$$L_{CD}^{xo} = \int_0^b (1/2 x/b) Fb 1/EJ dx + 1 (-1) 1 Fb^2/EJ = [1/4 x^2/b]_0^b Fb 1/EJ + 1 (-1) 1 Fb^2/EJ$$

$$= (1/4 b) Fb 1/EJ + 1 (-1) 1 Fb^2/EJ = -3/4 Fb^2/EJ$$

$$L_{DC}^{xo} = \int_0^b (1/2 - 1/2 x/b) Fb 1/EJ dx + 1 (-1) 1 Fb^2/EJ = [1/2 x - 1/4 x^2/b]_0^b Fb 1/EJ + 1 (-1) 1 Fb^2/EJ$$

$$= (1/2 b - 1/4 b) Fb 1/EJ + 1 (-1) 1 Fb^2/EJ = -3/4 Fb^2/EJ$$

$$L_{DE}^{xo} = \int_0^b (1/2 - 1/2 x^2/b^2) Fb 1/EJ dx = [1/2 x - 1/6 x^3/b^2]_0^b Fb 1/EJ$$

$$= (1/2 b - 1/6 b) Fb 1/EJ = 1/3 Fb^2/EJ$$

$$L_{ED}^{xo} = \int_0^b (x/b - 1/2 x^2/b^2) Fb 1/EJ dx = [1/2 x^2/b - 1/6 x^3/b^2]_0^b Fb 1/EJ$$

$$= (1/2 b - 1/6 b) Fb 1/EJ = 1/3 Fb^2/EJ$$

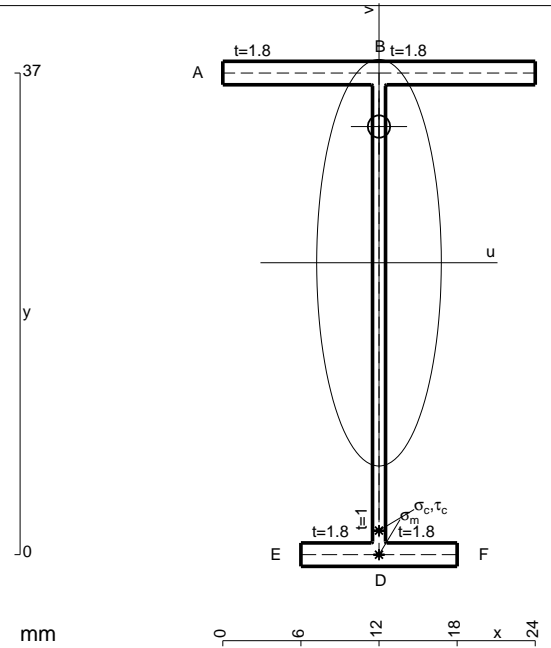

- A = 101.8 mm²
- J_u = 24830. mm⁴
- J_v = 2333. mm⁴
- J_I = 82.32 mm⁴
- y_o = 10.46 mm
- y_g = 22.43 mm
- N = -520. N
- T_y = -520. N
- M_x = -245700. Nmm
- x_m = 12. mm
- v_m = -22.43 mm
- σ_m = N/A - Mv/J_u = -227. N/mm²
- y_c = 3. mm
- u_c = -12. mm
- v_c = -19.43 mm
- σ_c = N/A - Mv/J_u = -227. N/mm²
- τ_c = TS_v/tJ_u = 10.14 N/mm²
- τ_g = TS_v/tJ_u = 10.14 N/mm²
- t_c = 260. mm
- σ_o = √(σ² + 3τ²) = 227.7 N/mm²

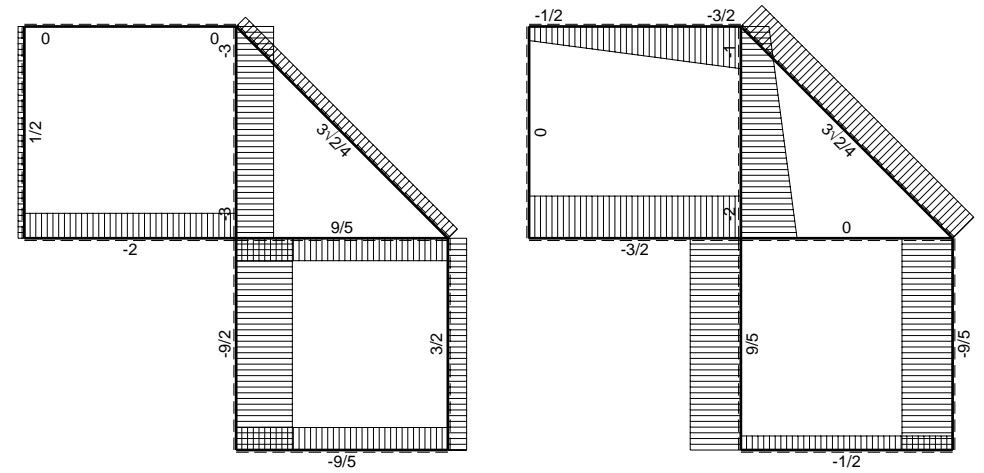
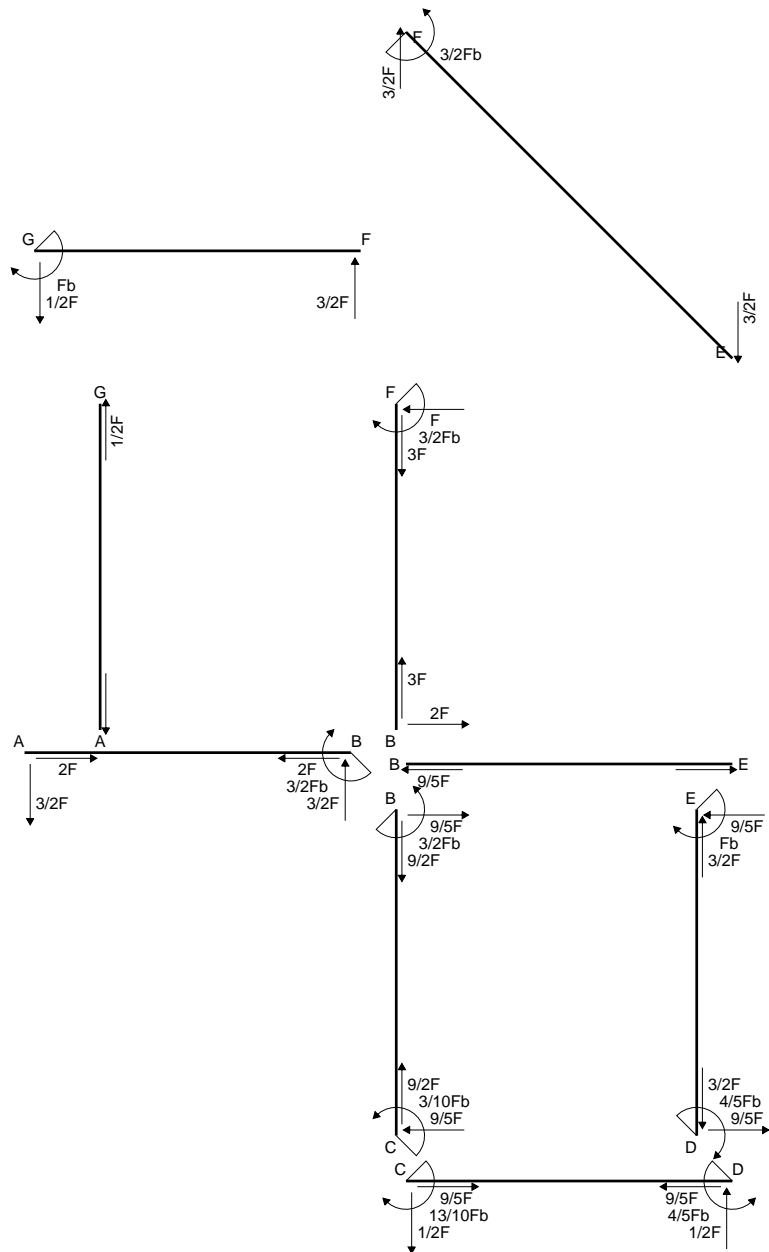

← ⊕ → F

↑ ⊕ ↓ F

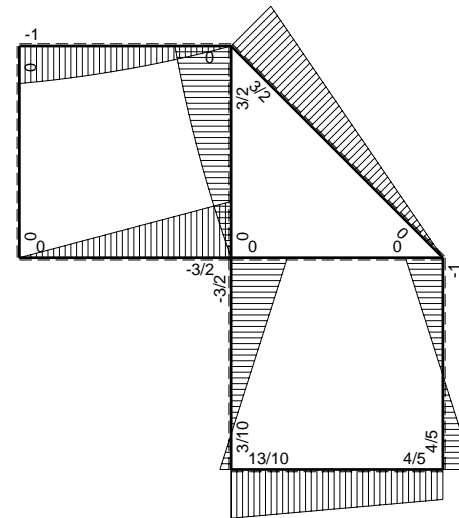

⊕ ⊖ Fb

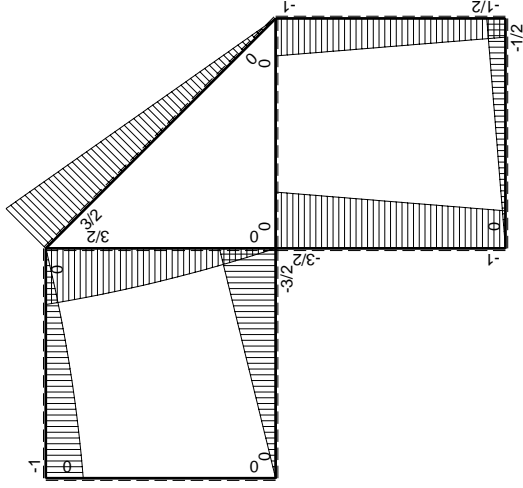
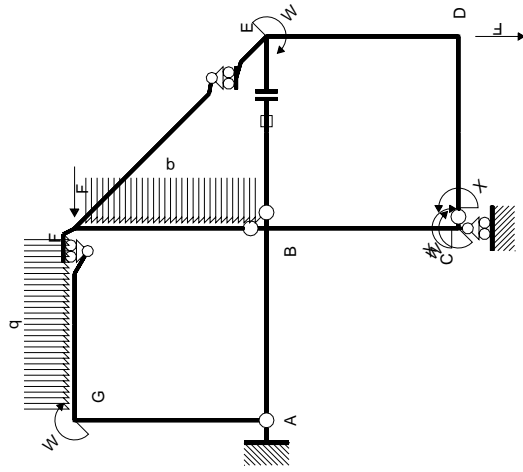

Schema di calcolo iperstatico

M_0 flessione da carichi assegnati

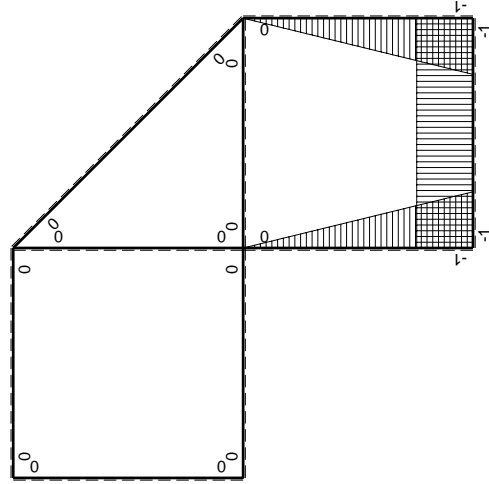

M_x flessione da iperstatica X=1

Quadro contribuiti PLV per iperstatica X=W_{CD}

→	$M_x(x)$	$M_0(x)$	$M_x M_0$	$M_x M_x$	$\int M_x M_0 / E J dx$	$\int M_x M_x / E J dx$
AB b	0	-3/2Fx	0	0	0	0
BA b	0	3/2Fb-3/2Fx	0	0	0	0
BC b	-x/b	-3/2Fb+1/2Fx	3/2Fx-1/2Fx ² /b	x ² /b ²	7/12Fb ² /EJ	1/3Xb/EJ
CB b	1-x/b	Fb+1/2Fx	Fb-1/2Fx-1/2Fx ² /b	1-2x/b+x ² /b ²	1/4Fb ² /EJ	Xb/EJ
CD b	-1	-1/2Fx	1/2Fx	1	1/4Fb ² /EJ	Xb/EJ
DC b	1	1/2Fb-1/2Fx	1/2Fb-1/2Fx	1	1/3Fb ² /EJ	1/3Xb/EJ
DE b	-1+x/b	-1/2Fb-1/2Fx	1/2Fb-1/2Fx ² /b	1-2x/b+x ² /b ²	1/3Fb ² /EJ	1/3Xb/EJ
ED b	x/b	Fb-1/2Fx	Fx-1/2Fx ² /b	x ² /b ²	0	0
EF √2b	0	3√2/4Fx	0	0	0	0
FG b	0	-3/2Fx+1/2qx ²	0	0	0	0
GF b	0	Fb-1/2Fx-1/2qx ²	0	0	0	0
GA b	0	0	0	0	0	0
AG b	0	0	0	0	0	0
FB b	0	3/2Fb-Fx-1/2qx ²	0	0	0	0
BF b	0	-2Fx+1/2qx ²	0	0	0	0
BE b	0	0	0	0	0	0
EB b	0	0	0	0	0	0
BE	elongazione asta $N_{1, BE}^E - BE$				Fb ² /EJ	
	totali				13/6Fb ² /EJ	5/3Xb/EJ
	iperstatica X=W _{CD}				-13/10Fb	

Sviluppi di calcolo iperstatica

$$L_{BC}^{xx} = \int_0^b (x^2/b^2) 1/EJ dx = [1/3 x^3/b^2]_0^b 1/EJ$$

$$= (1/3 b) 1/EJ = 1/3 b/EJ$$

$$L_{CB}^{xx} = \int_0^b (1 - 2x/b + x^2/b^2) 1/EJ dx = [x - x^2/b + 1/3 x^3/b^2]_0^b 1/EJ$$

$$= (b - b + 1/3 b) 1/EJ = 1/3 b/EJ$$

$$L_{CD}^{xx} = \int_0^b (1) 1/EJ dx = [x]_0^b 1/EJ$$

$$= (b) 1/EJ = b/EJ$$

$$L_{DC}^{xx} = \int_0^b (1) 1/EJ dx = [x]_0^b 1/EJ$$

$$= (b) 1/EJ = b/EJ$$

$$L_{DE}^{xx} = \int_0^b (1 - 2x/b + x^2/b^2) 1/EJ dx = [x - x^2/b + 1/3 x^3/b^2]_0^b 1/EJ$$

$$= (b - b + 1/3 b) 1/EJ = 1/3 b/EJ$$

$$L_{ED}^{xx} = \int_0^b (x^2/b^2) 1/EJ dx = [1/3 x^3/b^2]_0^b 1/EJ$$

$$= (1/3 b) 1/EJ = 1/3 b/EJ$$

$$L_{BC}^{xo} = \int_0^b (3/2 x/b - 1/2 x^2/b^2) Fb 1/EJ dx = [3/4 x^2/b - 1/6 x^3/b^2]_0^b Fb 1/EJ$$

$$= (3/4 b - 1/6 b) Fb 1/EJ = 7/12 Fb^2/EJ$$

$$L_{CB}^{xo} = \int_0^b (1 - 1/2 x/b - 1/2 x^2/b^2) Fb 1/EJ dx = [x - 1/4 x^2/b - 1/6 x^3/b^2]_0^b Fb 1/EJ$$

$$= (b - 1/4 b - 1/6 b) Fb 1/EJ = 7/12 Fb^2/EJ$$

$$L_{CD}^{xo} = \int_0^b (1/2 x/b) Fb 1/EJ dx = [1/4 x^2/b]_0^b Fb 1/EJ$$

$$= (1/4 b) Fb 1/EJ = 1/4 Fb^2/EJ$$

$$L_{DC}^{xo} = \int_0^b (1/2 - 1/2 x/b) Fb 1/EJ dx = [1/2 x - 1/4 x^2/b]_0^b Fb 1/EJ$$

$$= (1/2 b - 1/4 b) Fb 1/EJ = 1/4 Fb^2/EJ$$

$$L_{DE}^{xo} = \int_0^b (1/2 - 1/2 x^2/b^2) Fb 1/EJ dx = [1/2 x - 1/6 x^3/b^2]_0^b Fb 1/EJ$$

$$= (1/2 b - 1/6 b) Fb 1/EJ = 1/3 Fb^2/EJ$$

$$L_{ED}^{xo} = \int_0^b (x/b - 1/2 x^2/b^2) Fb 1/EJ dx = [1/2 x^2/b - 1/6 x^3/b^2]_0^b Fb 1/EJ$$

$$= (1/2 b - 1/6 b) Fb 1/EJ = 1/3 Fb^2/EJ$$

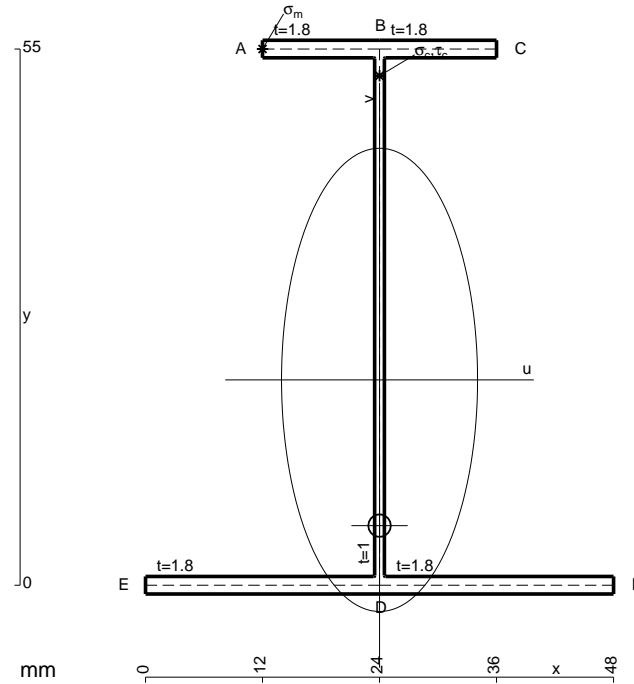

- A = 184.6 mm²
- J_u = 104229. mm⁴
- J_v = 18662. mm⁴
- J_t = 158.3 mm⁴
- y_o = -14.95 mm
- y_g = 21.06 mm
- N = -1020. N
- T_y = -765. N
- M_x = -749700. Nmm
- x_m = 12. mm
- y_m = 55. mm
- u_m = -12. mm
- v_m = 33.94 mm
- σ_m = N/A - Mv/J_u = 238.6 N/mm²
- x_c = 24. mm
- y_c = 55. mm
- v_c = 33.94 mm
- σ_c = N/A - Mv/J_u = 238.6 N/mm²
- τ_c = TS_y/tJ_u = 10.76 N/mm²
- τ_g = TS_y/tJ_u = 10.76 N/mm²
- t_c = 510. mm
- σ_o = √σ² + 3τ² = 239.3 N/mm²

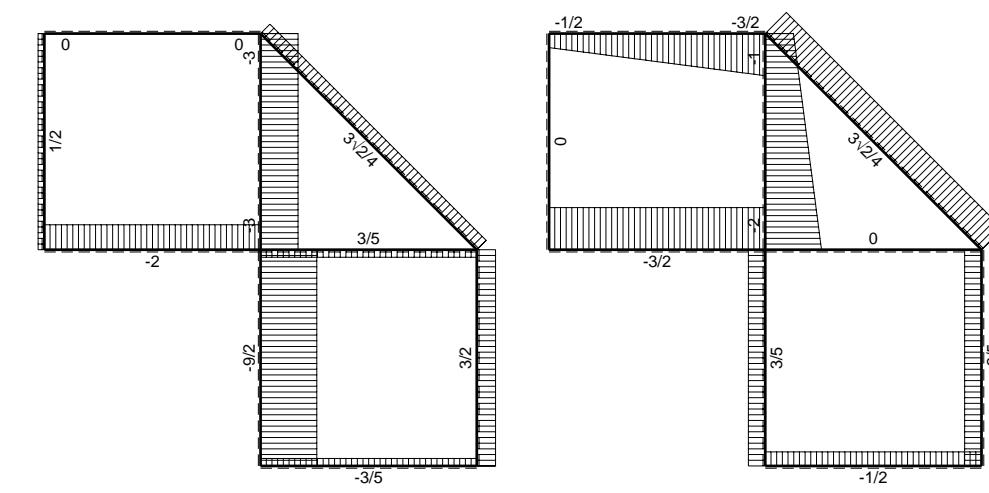
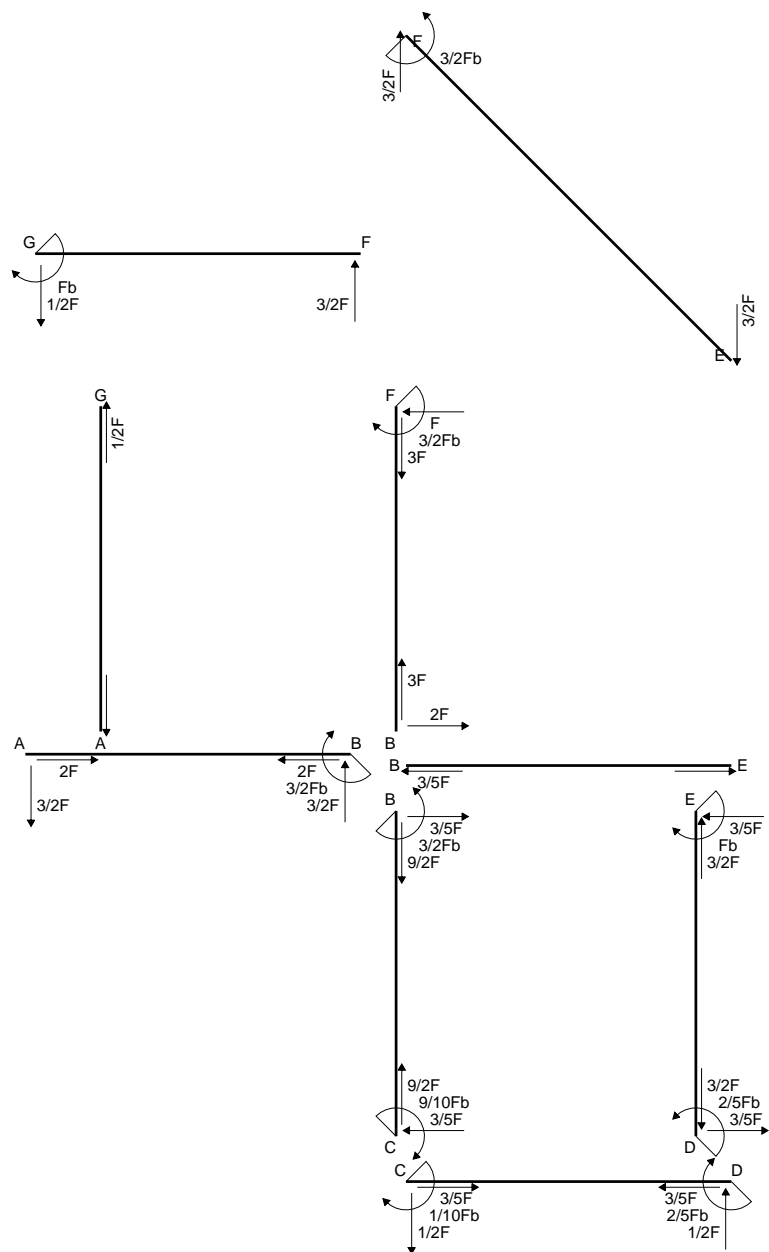

← ⊕ → F

↑ ⊕ ↓ F

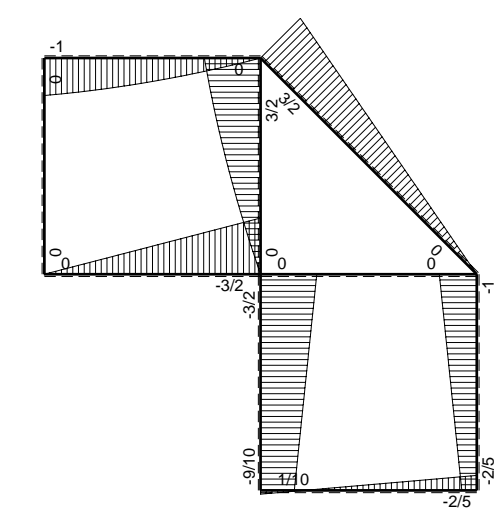

⊕ ↻ Fb

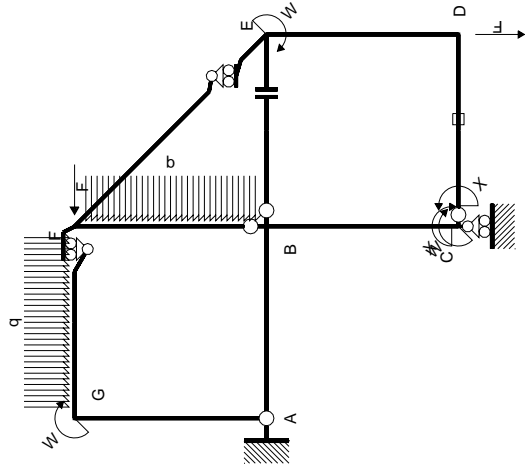

Schema di calcolo iperstatico

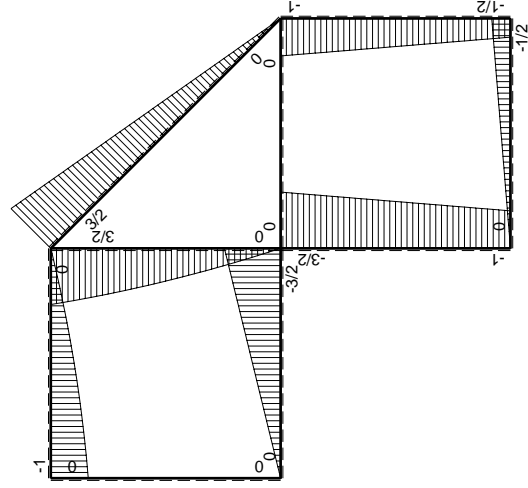

M_0 flessione da carichi assegnati

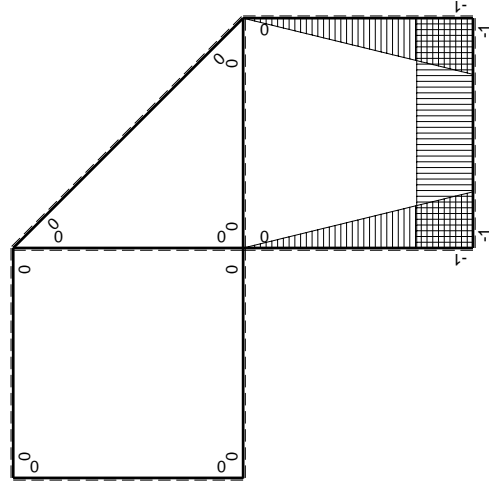

M_x flessione da iperstatica $X=1$

Quadro contributi PLV per iperstatica $X=W_{cd}$

\rightarrow	$M_x(x)$	$M_0(x)$	$M_x M_0$	$M_x M_x$	$\int M_x M_0 / E J dx$	$\int M_x M_x / E J dx$
AB b	0	$-3/2Fx$	0	0	0	0
BA b	0	$3/2Fb-3/2Fx$	0	0	0	0
BC b	$-x/b$	$-3/2Fb+1/2Fx$	$3/2Fx-1/2Fx^2/b$	x^2/b^2	$7/12Fb^2/EJ$	$1/3Xb/EJ$
CB b	$1-x/b$	$Fb+1/2Fx$	$Fb-1/2Fx-1/2Fx^2/b$	$1-2x/b+x^2/b^2$		
CD b	-1	$-1/2Fx$	$1/2Fx$	1	$1/4Fb^2/EJ$	Xb/EJ
DC b	1	$1/2Fb-1/2Fx$	$1/2Fb-1/2Fx$	1		
DE b	$-1+x/b$	$-1/2Fb-1/2Fx$	$1/2Fb-1/2Fx^2/b$	$1-2x/b+x^2/b^2$	$1/3Fb^2/EJ$	$1/3Xb/EJ$
ED b	x/b	$Fb-1/2Fx$	$Fx-1/2Fx^2/b$	x^2/b^2		
EF $\sqrt{2}b$	0	$3\sqrt{2}/4Fx$	0	0	0	0
FG b	0	$-3/2Fx+1/2qx^2$	0	0	0	0
GF b	0	$Fb-1/2Fx-1/2qx^2$	0	0	0	0
GA b	0	0	0	0	0	0
AG b	0	0	0	0	0	0
FB b	0	$3/2Fb-Fx-1/2qx^2$	0	0	0	0
BF b	0	$-2Fx+1/2qx^2$	0	0	0	0
BE b	0	0	0	0	0	0
EB b	0	0	0	0	0	0
CD	elongazione asta $N_{1,cd} \epsilon_{cd} L_{cd}$				$-Fb^2/EJ$	
	totali				$1/6Fb^2/EJ$	$5/3Xb/EJ$
	iperstatica $X=W_{cd}$				$-1/10Fb$	

Sviluppi di calcolo iperstatica

$$L_{BC}^{xx} = \int_0^b (x^2/b^2) 1/EJ dx = [1/3 x^3/b^2]_0^b 1/EJ$$

$$= (1/3 b) 1/EJ = 1/3 b/EJ$$

$$L_{CB}^{xx} = \int_0^b (1 - 2x/b + x^2/b^2) 1/EJ dx = [x - x^2/b + 1/3 x^3/b^2]_0^b 1/EJ$$

$$= (b - b + 1/3 b) 1/EJ = 1/3 b/EJ$$

$$L_{CD}^{xx} = \int_0^b (1) 1/EJ dx = [x]_0^b 1/EJ$$

$$= (b) 1/EJ = b/EJ$$

$$L_{DC}^{xx} = \int_0^b (1) 1/EJ dx = [x]_0^b 1/EJ$$

$$= (b) 1/EJ = b/EJ$$

$$L_{DE}^{xx} = \int_0^b (1 - 2x/b + x^2/b^2) 1/EJ dx = [x - x^2/b + 1/3 x^3/b^2]_0^b 1/EJ$$

$$= (b - b + 1/3 b) 1/EJ = 1/3 b/EJ$$

$$L_{ED}^{xx} = \int_0^b (x^2/b^2) 1/EJ dx = [1/3 x^3/b^2]_0^b 1/EJ$$

$$= (1/3 b) 1/EJ = 1/3 b/EJ$$

$$L_{BC}^{xo} = \int_0^b (3/2 x/b - 1/2 x^2/b^2) Fb 1/EJ dx = [3/4 x^2/b - 1/6 x^3/b^2]_0^b Fb 1/EJ$$

$$= (3/4 b - 1/6 b) Fb 1/EJ = 7/12 Fb^2/EJ$$

$$L_{CB}^{xo} = \int_0^b (1 - 1/2 x/b - 1/2 x^2/b^2) Fb 1/EJ dx = [x - 1/4 x^2/b - 1/6 x^3/b^2]_0^b Fb 1/EJ$$

$$= (b - 1/4 b - 1/6 b) Fb 1/EJ = 7/12 Fb^2/EJ$$

$$L_{CD}^{xo} = \int_0^b (1/2 x/b) Fb 1/EJ dx + 1 (-1) 1 Fb^2/EJ = [1/4 x^2/b]_0^b Fb 1/EJ + 1 (-1) 1 Fb^2/EJ$$

$$= (1/4 b) Fb 1/EJ + 1 (-1) 1 Fb^2/EJ = -3/4 Fb^2/EJ$$

$$L_{DC}^{xo} = \int_0^b (1/2 - 1/2 x/b) Fb 1/EJ dx + 1 (-1) 1 Fb^2/EJ = [1/2 x - 1/4 x^2/b]_0^b Fb 1/EJ + 1 (-1) 1 Fb^2/EJ$$

$$= (1/2 b - 1/4 b) Fb 1/EJ + 1 (-1) 1 Fb^2/EJ = -3/4 Fb^2/EJ$$

$$L_{DE}^{xo} = \int_0^b (1/2 - 1/2 x^2/b^2) Fb 1/EJ dx = [1/2 x - 1/6 x^3/b^2]_0^b Fb 1/EJ$$

$$= (1/2 b - 1/6 b) Fb 1/EJ = 1/3 Fb^2/EJ$$

$$L_{ED}^{xo} = \int_0^b (x/b - 1/2 x^2/b^2) Fb 1/EJ dx = [1/2 x^2/b - 1/6 x^3/b^2]_0^b Fb 1/EJ$$

$$= (1/2 b - 1/6 b) Fb 1/EJ = 1/3 Fb^2/EJ$$

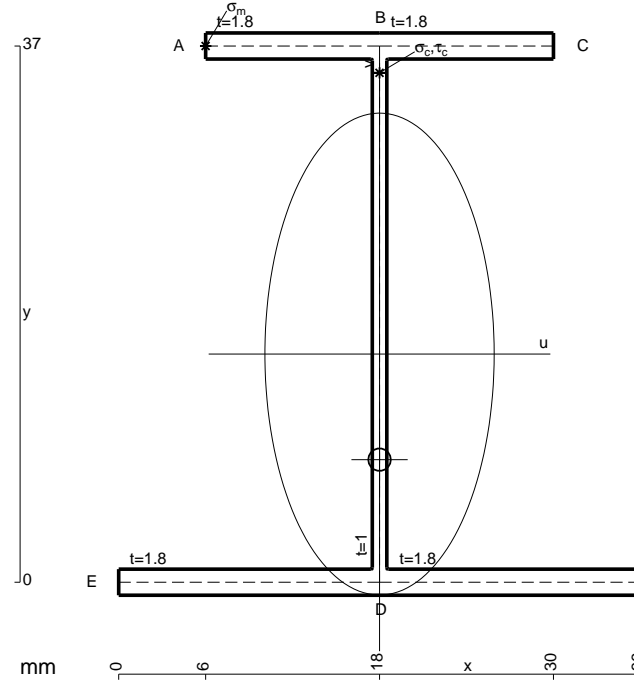

- A = 145. mm²
- J_u = 40083. mm⁴
- J_v = 9072. mm⁴
- J_t = 129. mm⁴
- y_o = -7.287 mm
- y_g = 15.74 mm
- N = -1500. N
- T_y = -1125. N
- M_x = -393750. Nmm
- x_m = 6. mm
- y_m = 37. mm
- u_m = -12. mm
- v_m = 21.26 mm
- σ_m = N/A-Mv/J_u = 198.5 N/mm²
- x_c = 18. mm
- y_c = 37. mm
- v_c = 21.26 mm
- σ_c = N/A-Mv/J_u = 198.5 N/mm²
- τ_c = TS_y/tJ_u = 25.77 N/mm²
- τ_g = TS_y/tJ_u = 25.77 N/mm²
- t_c = 750. mm
- σ_o = √σ²+3τ² = 203.4 N/mm²

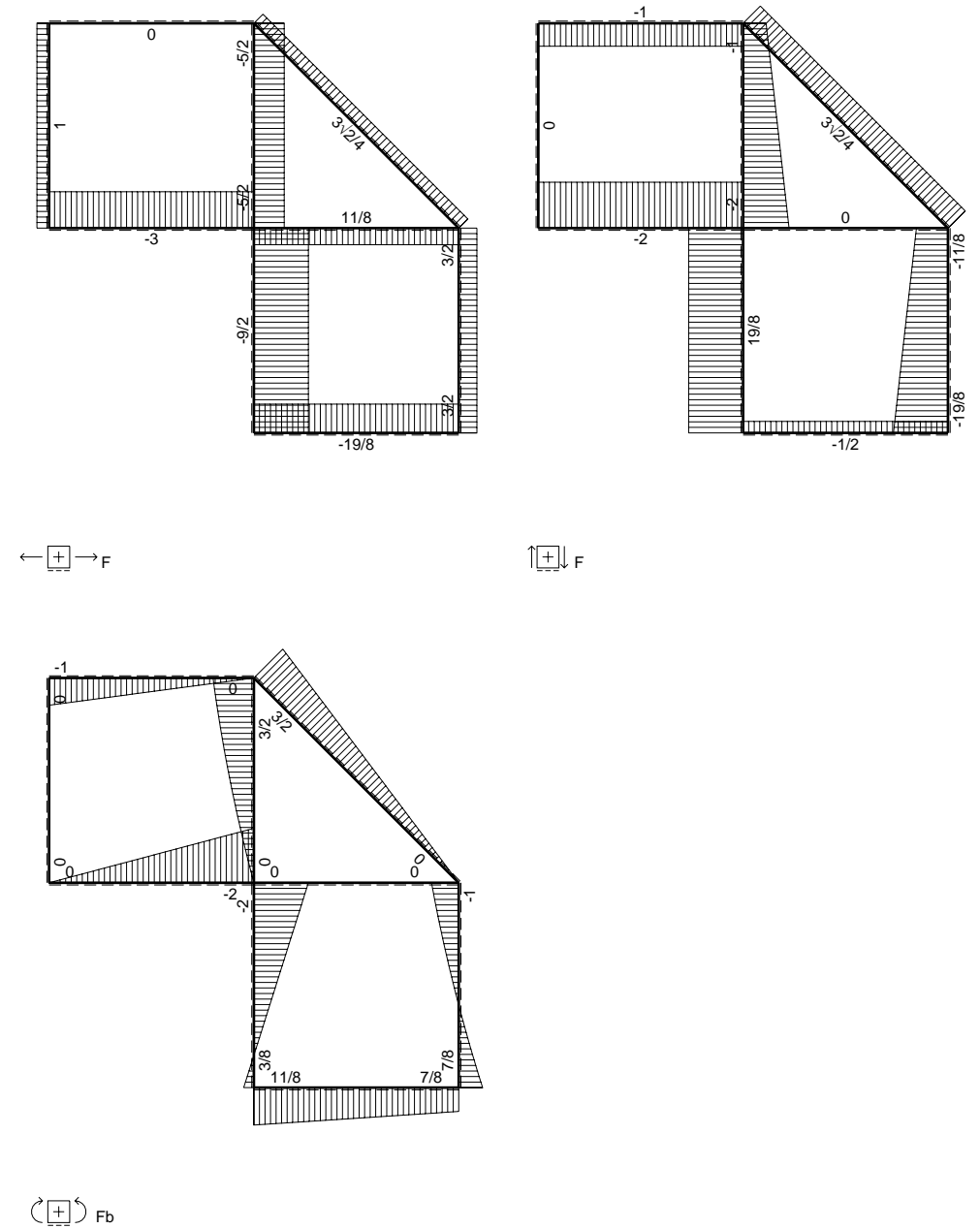
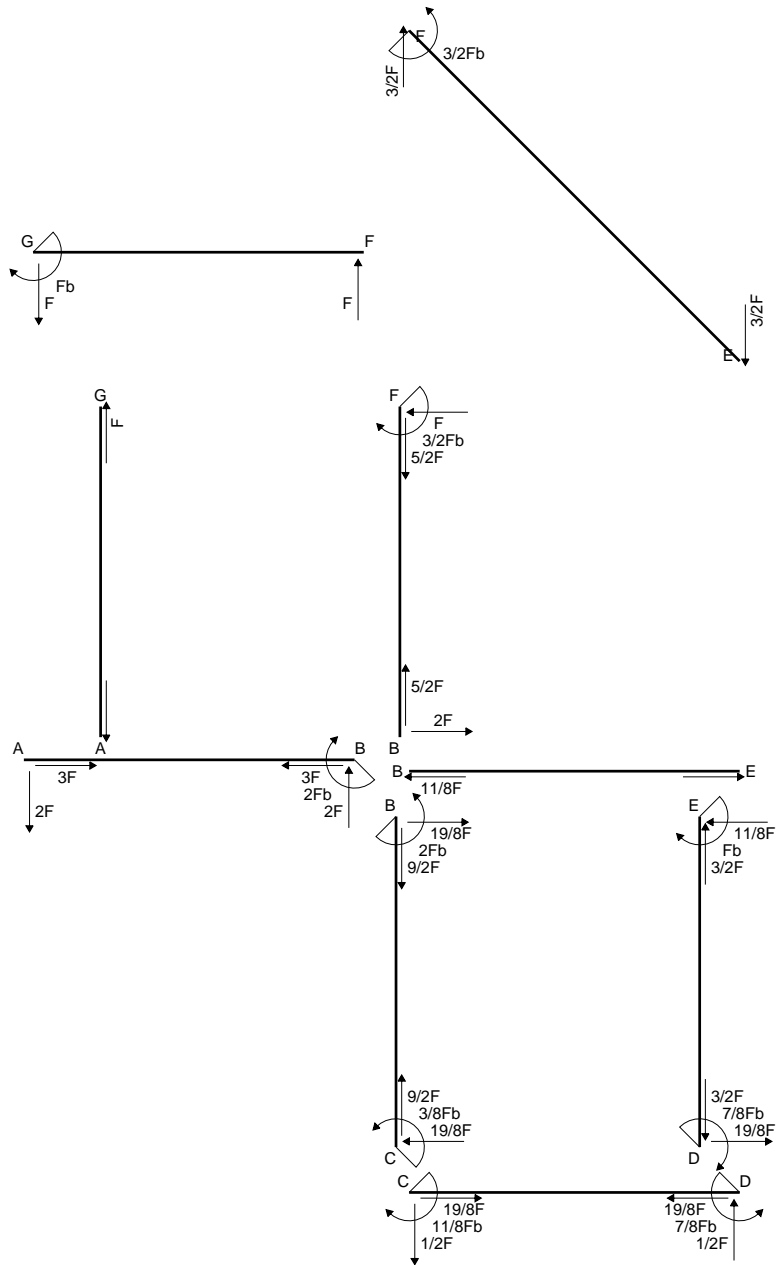

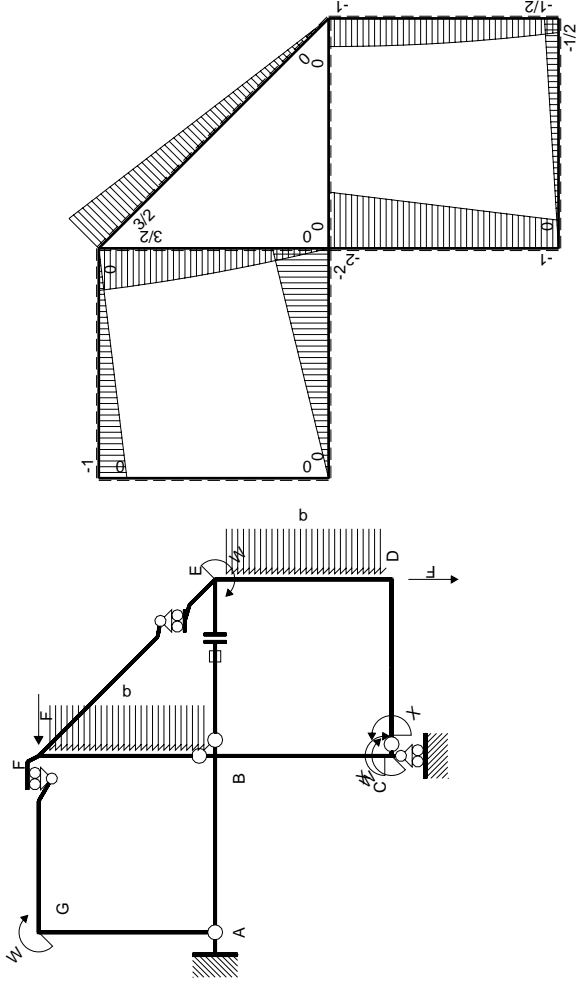

Schema di calcolo iperstatico

M_0 flessione da carichi assegnati

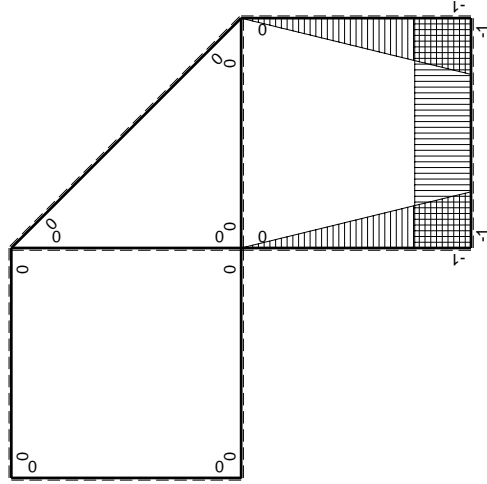

M_x flessione da iperstatica $X=1$

Quadro contributi PLV per iperstatica $X=W_{CD}$

→	$M_x(x)$	$M_o(x)$	$M_x M_o$	$M_x M_x$	$\int M_x M_o / EJ dx$	$\int X M_x M_x / EJ dx$
AB b	0	-2Fx	0	0	0	0
BA b	0	2Fb-2Fx	0	0		
BC b	-x/b	-2Fb+Fx	$2Fx-Fx^2/b$	x^2/b^2	$2/3Fb^2/EJ$	$1/3Xb/EJ$
CB b	1-x/b	Fb+Fx	$Fb-Fx^2/b$	$1-2x/b+x^2/b^2$		
CD b	-1	-1/2Fx	1/2Fx	1	$1/4Fb^2/EJ$	Xb/EJ
DC b	1	1/2Fb-1/2Fx	1/2Fb-1/2Fx	1		
DE b	-1+x/b	$-1/2Fb-Fx+1/2qx^2$	$1/2Fb+1/2Fx-3/2Fx^2/b+1/2qx^3/b$	$1-2x/b+x^2/b^2$	$3/8Fb^2/EJ$	$1/3Xb/EJ$
ED b	x/b	$Fb-1/2qx^2$	$Fx-1/2qx^3/b$	x^2/b^2		
EF $\sqrt{2}b$	0	$3\sqrt{2}/4Fx$	0	0	0	0
FG b	0	-Fx	0	0	0	0
GF b	0	Fb-Fx	0	0		
GA b	0	0	0	0	0	0
AG b	0	0	0	0		
FB b	0	$3/2Fb-Fx-1/2qx^2$	0	0	0	0
BF b	0	$-2Fx+1/2qx^2$	0	0		
BE b	0	0	0	0	0	0
EB b	0	0	0	0		
BE	elongazione asta $N_{1BE} \epsilon_{BE} L_{BE}$				Fb^2/EJ	
	totali				$55/24Fb^2/EJ$	$5/3Xb/EJ$
	iperstatica $X=W_{CD}$				$-11/8Fb$	

Sviluppi di calcolo iperstatica

$$L_{BC}^{xx} = \int_0^b (x^2/b^2) 1/EJ dx = [1/3 x^3/b^2]_0^b 1/EJ$$

$$= (1/3 b) 1/EJ = 1/3 b/EJ$$

$$L_{CB}^{xx} = \int_0^b (1 - 2x/b + x^2/b^2) 1/EJ dx = [x - x^2/b + 1/3 x^3/b^2]_0^b 1/EJ$$

$$= (b - b + 1/3 b) 1/EJ = 1/3 b/EJ$$

$$L_{CD}^{xx} = \int_0^b (1) 1/EJ dx = [x]_0^b 1/EJ$$

$$= (b) 1/EJ = b/EJ$$

$$L_{DC}^{xx} = \int_0^b (1) 1/EJ dx = [x]_0^b 1/EJ$$

$$= (b) 1/EJ = b/EJ$$

$$L_{DE}^{xx} = \int_0^b (1 - 2x/b + x^2/b^2) 1/EJ dx = [x - x^2/b + 1/3 x^3/b^2]_0^b 1/EJ$$

$$= (b - b + 1/3 b) 1/EJ = 1/3 b/EJ$$

$$L_{ED}^{xx} = \int_0^b (x^2/b^2) 1/EJ dx = [1/3 x^3/b^2]_0^b 1/EJ$$

$$= (1/3 b) 1/EJ = 1/3 b/EJ$$

$$L_{BC}^{xo} = \int_0^b (2x/b - x^2/b^2) Fb 1/EJ dx = [x^2/b - 1/3 x^3/b^2]_0^b Fb 1/EJ$$

$$= (b - 1/3 b) Fb 1/EJ = 2/3 Fb^2/EJ$$

$$L_{CB}^{xo} = \int_0^b (1 - x^2/b^2) Fb 1/EJ dx = [x - 1/3 x^3/b^2]_0^b Fb 1/EJ$$

$$= (b - 1/3 b) Fb 1/EJ = 2/3 Fb^2/EJ$$

$$L_{CD}^{xo} = \int_0^b (1/2 x/b) Fb 1/EJ dx = [1/4 x^2/b]_0^b Fb 1/EJ$$

$$= (1/4 b) Fb 1/EJ = 1/4 Fb^2/EJ$$

$$L_{DC}^{xo} = \int_0^b (1/2 - 1/2 x/b) Fb 1/EJ dx = [1/2 x - 1/4 x^2/b]_0^b Fb 1/EJ$$

$$= (1/2 b - 1/4 b) Fb 1/EJ = 1/4 Fb^2/EJ$$

$$L_{DE}^{xo} = \int_0^b (1/2 + 1/2 x/b - 3/2 x^2/b^2 + 1/2 x^3/b^3) Fb 1/EJ dx$$

$$= [1/2 x + 1/4 x^2/b - 1/2 x^3/b^2 + 1/8 x^4/b^3]_0^b Fb 1/EJ$$

$$= (1/2 b + 1/4 b - 1/2 b + 1/8 b) Fb 1/EJ = 3/8 Fb^2/EJ$$

$$L_{ED}^{xo} = \int_0^b (x/b - 1/2 x^3/b^3) Fb 1/EJ dx = [1/2 x^2/b - 1/8 x^4/b^3]_0^b Fb 1/EJ$$

$$= (1/2 b - 1/8 b) Fb 1/EJ = 3/8 Fb^2/EJ$$

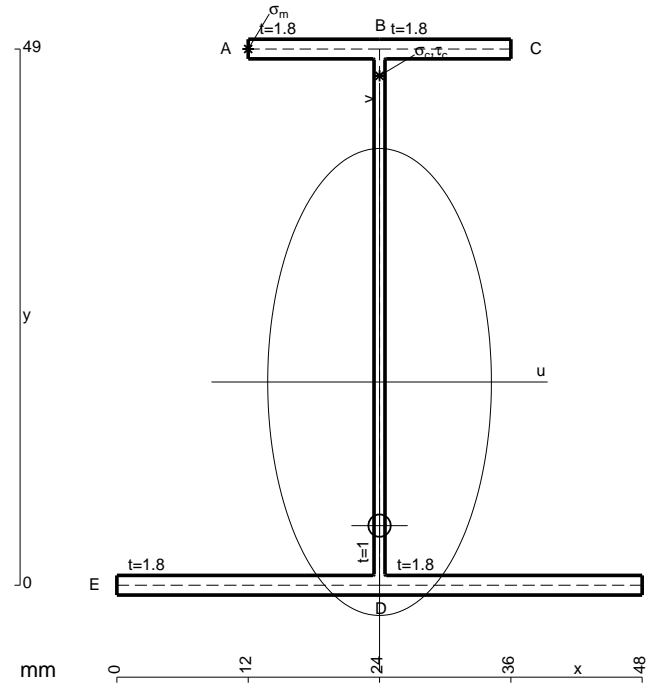

$A = 178.6 \text{ mm}^2$
 $J_u = 81324. \text{ mm}^4$
 $J_v = 18662. \text{ mm}^4$
 $J_t = 156.3 \text{ mm}^4$
 $y_o = -13.13 \text{ mm}$
 $y_g = 18.57 \text{ mm}$
 $N = -1740. \text{ N}$
 $T_y = -1160. \text{ N}$
 $M_x = -580000. \text{ Nmm}$
 $x_m = 12. \text{ mm}$
 $y_m = 49. \text{ mm}$
 $u_m = -12. \text{ mm}$
 $v_m = 30.43 \text{ mm}$
 $\sigma_m = N/A - Mv/J_u = 207.3 \text{ N/mm}^2$
 $x_c = 24. \text{ mm}$
 $y_c = 49. \text{ mm}$
 $v_c = 30.43 \text{ mm}$
 $\sigma_c = N/A - Mv/J_u = 207.3 \text{ N/mm}^2$
 $\tau_c = TS'/tJ_u = 18.75 \text{ N/mm}^2$
 $\tau_g = TS'/tJ_u = 18.75 \text{ N/mm}^2$
 $t_c = 580. \text{ mm}$
 $\sigma_o = \sqrt{\sigma^2 + 3\tau^2} = 209.8 \text{ N/mm}^2$

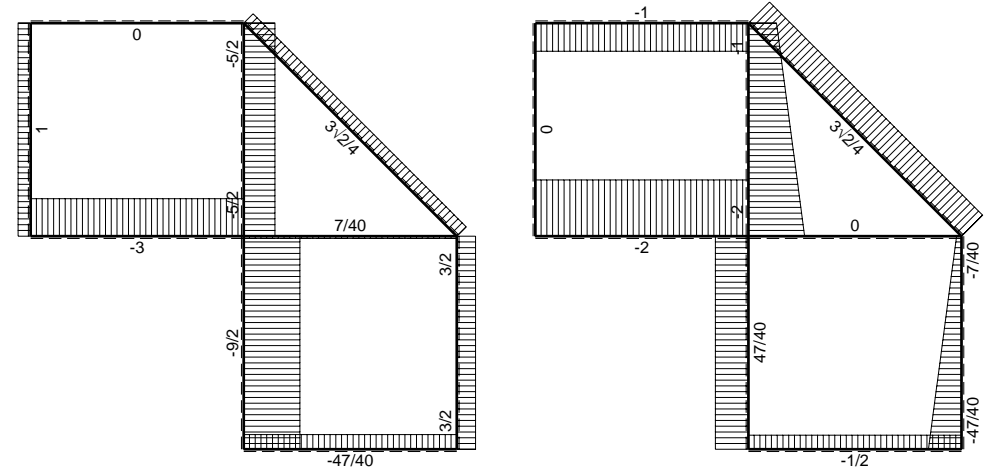
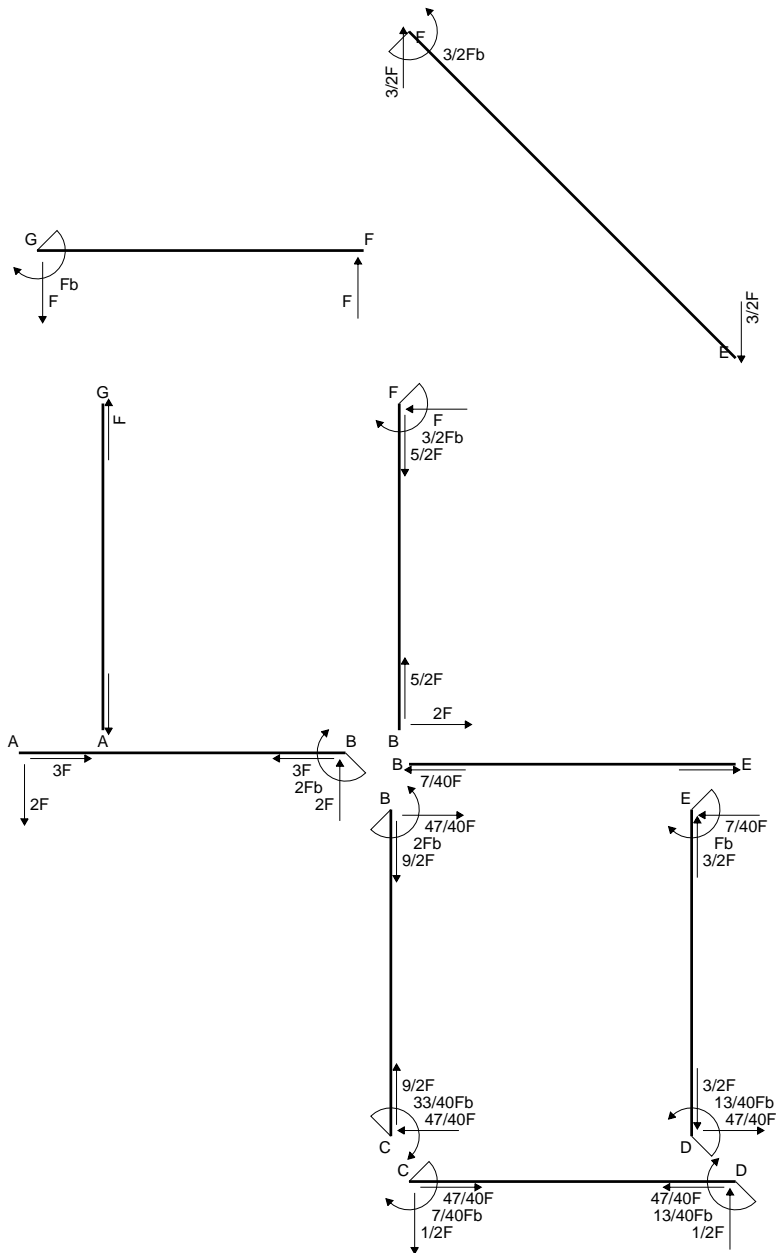

← ⊕ → F

↑ ⊕ ↓ F

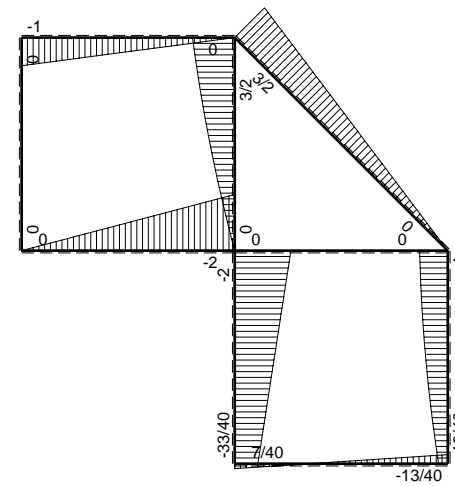

⊕ ⊖ F_b

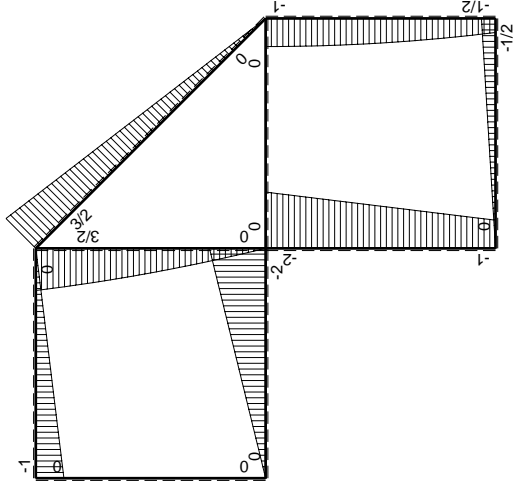
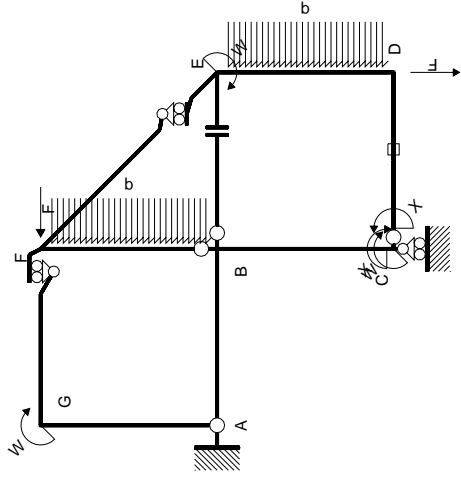

Schema di calcolo iperstatico

M_0 flessione da carichi assegnati

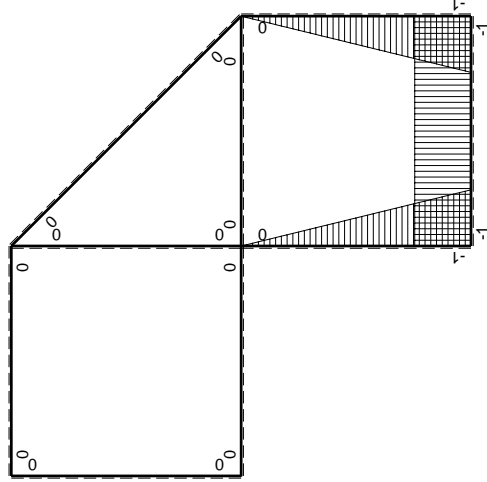

M_X flessione da iperstatica $X=1$

Quadro contributi PLV per iperstatica $X=W_{CD}$

→	$M_x(x)$	$M_o(x)$	$M_x M_o$	$M_x M_x$	$\int M_x M_o / EJ dx$	$\int X M_x M_x / EJ dx$
AB b	0	-2Fx	0	0	0	0
BA b	0	2Fb-2Fx	0	0		
BC b	-x/b	-2Fb+Fx	$2Fx-Fx^2/b$	x^2/b^2	$2/3Fb^2/EJ$	$1/3Xb/EJ$
CB b	1-x/b	Fb+Fx	$Fb-Fx^2/b$	$1-2x/b+x^2/b^2$		
CD b	-1	-1/2Fx	1/2Fx	1	$1/4Fb^2/EJ$	Xb/EJ
DC b	1	1/2Fb-1/2Fx	1/2Fb-1/2Fx	1		
DE b	-1+x/b	$-1/2Fb-Fx+1/2qx^2$	$1/2Fb+1/2Fx-3/2Fx^2/b+1/2qx^3/b$	$1-2x/b+x^2/b^2$	$3/8Fb^2/EJ$	$1/3Xb/EJ$
ED b	x/b	$Fb-1/2qx^2$	$Fx-1/2qx^3/b$	x^2/b^2		
EF $\sqrt{2}b$	0	$3\sqrt{2}/4Fx$	0	0	0	0
FG b	0	-Fx	0	0	0	0
GF b	0	Fb-Fx	0	0		
GA b	0	0	0	0	0	0
AG b	0	0	0	0		
FB b	0	$3/2Fb-Fx-1/2qx^2$	0	0	0	0
BF b	0	$-2Fx+1/2qx^2$	0	0		
BE b	0	0	0	0	0	0
EB b	0	0	0	0		
CD	elongazione asta $N_{iCD} \epsilon_{CD} L_{CD}$				$-Fb^2/EJ$	
	totali				$7/24Fb^2/EJ$	$5/3Xb/EJ$
	iperstatica $X=W_{CD}$				$-7/40Fb$	

Sviluppi di calcolo iperstatica

$$L_{BC}^{xx} = \int_0^b (x^2/b^2) 1/EJ dx = [1/3 x^3/b^2]_0^b 1/EJ$$

$$= (1/3 b) 1/EJ = 1/3 b/EJ$$

$$L_{CB}^{xx} = \int_0^b (1 - 2x/b + x^2/b^2) 1/EJ dx = [x - x^2/b + 1/3 x^3/b^2]_0^b 1/EJ$$

$$= (b - b + 1/3 b) 1/EJ = 1/3 b/EJ$$

$$L_{CD}^{xx} = \int_0^b (1) 1/EJ dx = [x]_0^b 1/EJ$$

$$= (b) 1/EJ = b/EJ$$

$$L_{DC}^{xx} = \int_0^b (1) 1/EJ dx = [x]_0^b 1/EJ$$

$$= (b) 1/EJ = b/EJ$$

$$L_{DE}^{xx} = \int_0^b (1 - 2x/b + x^2/b^2) 1/EJ dx = [x - x^2/b + 1/3 x^3/b^2]_0^b 1/EJ$$

$$= (b - b + 1/3 b) 1/EJ = 1/3 b/EJ$$

$$L_{ED}^{xx} = \int_0^b (x^2/b^2) 1/EJ dx = [1/3 x^3/b^2]_0^b 1/EJ$$

$$= (1/3 b) 1/EJ = 1/3 b/EJ$$

$$L_{BC}^{xo} = \int_0^b (2x/b - x^2/b^2) Fb 1/EJ dx = [x^2/b - 1/3 x^3/b^2]_0^b Fb 1/EJ$$

$$= (b - 1/3 b) Fb 1/EJ = 2/3 Fb^2/EJ$$

$$L_{CB}^{xo} = \int_0^b (1 - x^2/b^2) Fb 1/EJ dx = [x - 1/3 x^3/b^2]_0^b Fb 1/EJ$$

$$= (b - 1/3 b) Fb 1/EJ = 2/3 Fb^2/EJ$$

$$L_{CD}^{xo} = \int_0^b (1/2 x/b) Fb 1/EJ dx + 1 (-1) 1 Fb^2/EJ = [1/4 x^2/b]_0^b Fb 1/EJ + 1 (-1) 1 Fb^2/EJ$$

$$= (1/4 b) Fb 1/EJ + 1 (-1) 1 Fb^2/EJ = -3/4 Fb^2/EJ$$

$$L_{DC}^{xo} = \int_0^b (1/2 - 1/2 x/b) Fb 1/EJ dx + 1 (-1) 1 Fb^2/EJ = [1/2 x - 1/4 x^2/b]_0^b Fb 1/EJ + 1 (-1) 1 Fb^2/EJ$$

$$= (1/2 b - 1/4 b) Fb 1/EJ + 1 (-1) 1 Fb^2/EJ = -3/4 Fb^2/EJ$$

$$L_{DE}^{xo} = \int_0^b (1/2 + 1/2 x/b - 3/2 x^2/b^2 + 1/2 x^3/b^3) Fb 1/EJ dx$$

$$= [1/2 x + 1/4 x^2/b - 1/2 x^3/b^2 + 1/8 x^4/b^3]_0^b Fb 1/EJ$$

$$= (1/2 b + 1/4 b - 1/2 b + 1/8 b) Fb 1/EJ = 3/8 Fb^2/EJ$$

$$L_{ED}^{xo} = \int_0^b (x/b - 1/2 x^3/b^3) Fb 1/EJ dx = [1/2 x^2/b - 1/8 x^4/b^3]_0^b Fb 1/EJ$$

$$= (1/2 b - 1/8 b) Fb 1/EJ = 3/8 Fb^2/EJ$$

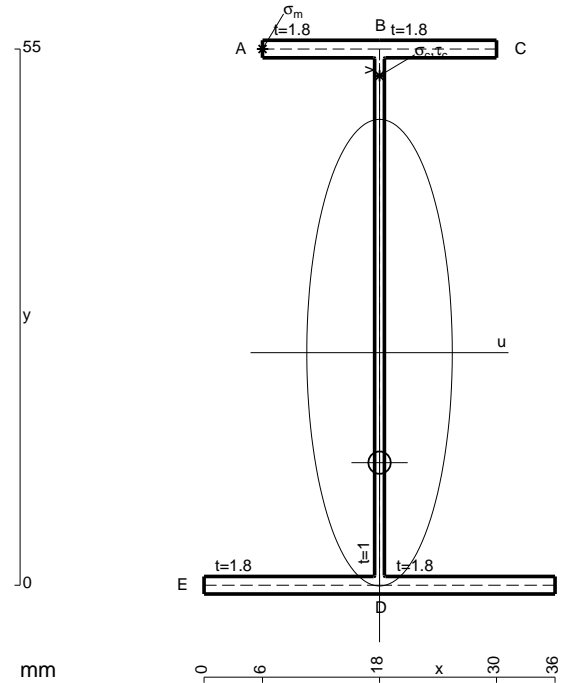

- A = 163. mm²
- J_u = 93375. mm⁴
- J_v = 9072. mm⁴
- J_t = 135. mm⁴
- y_o = -11.28 mm
- y_g = 23.86 mm
- N = -1650. N
- T_y = -1100. N
- M_x = -682000. Nmm
- x_m = 6. mm
- y_m = 55. mm
- u_m = -12. mm
- v_m = 31.14 mm
- σ_m = N/A - Mv/J_u = 217.4 N/mm²
- x_c = 18. mm
- y_c = 55. mm
- v_c = 31.14 mm
- σ_c = N/A - Mv/J_u = 217.4 N/mm²
- τ_c = TS_y/tJ_u = 15.85 N/mm²
- τ_g = TS_y/tJ_u = 15.85 N/mm²
- t_c = 550. mm
- σ_o = √σ² + 3τ² = 219.1 N/mm²

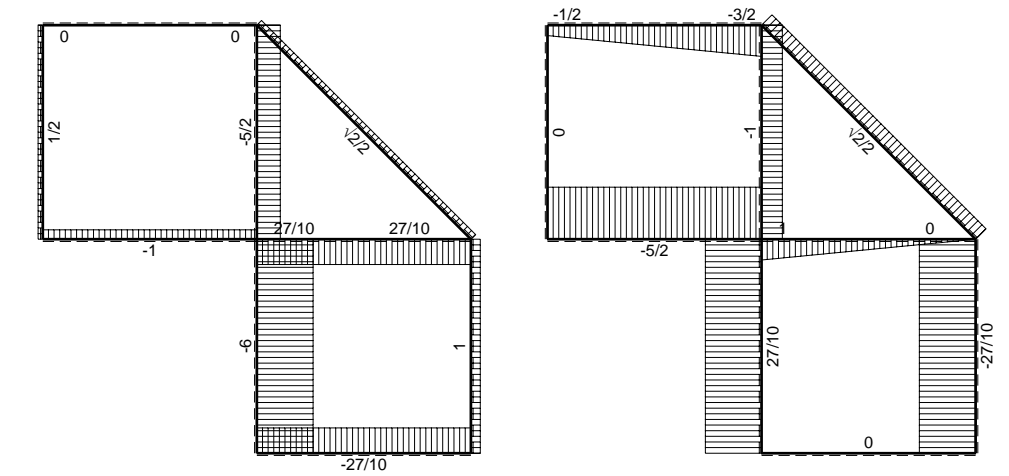
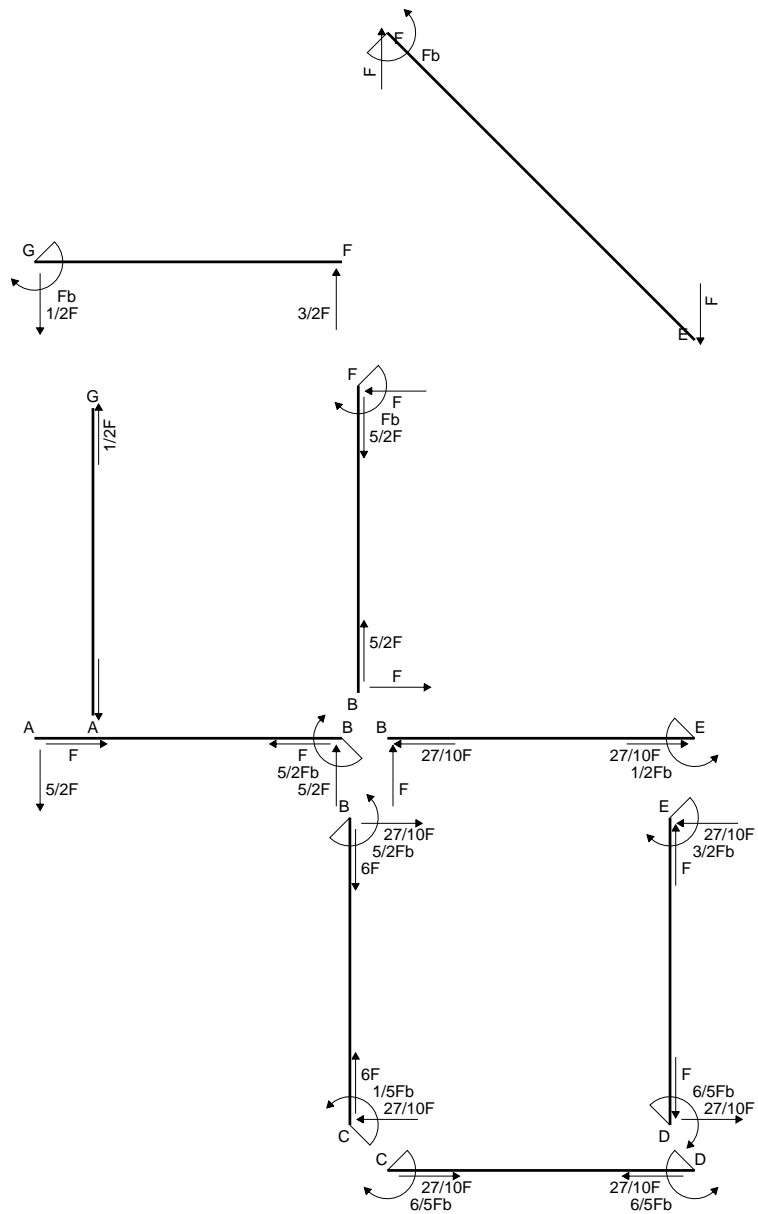

← ⊕ → F

↑ ⊕ ↓ Fb

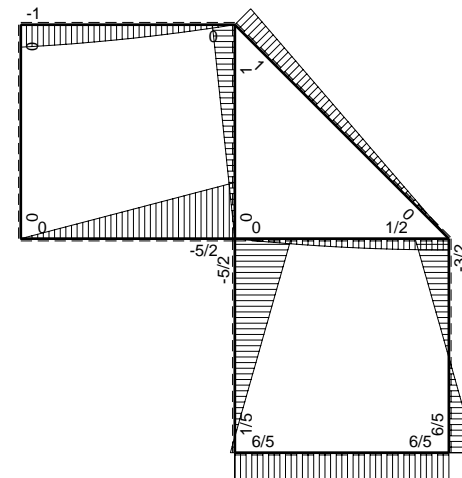

⊕ ⊖ Fb

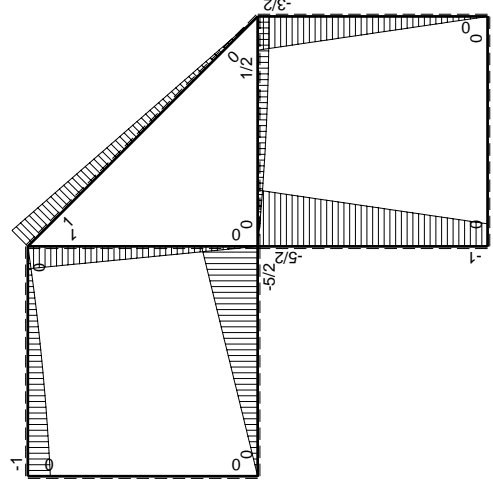
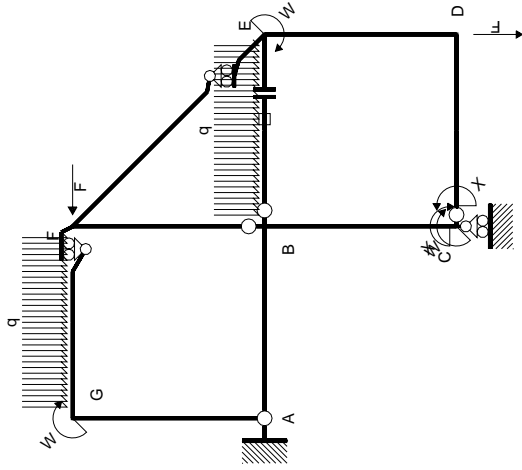

Schema di calcolo iperstatico

(\oplus) M_0 flessione da carichi assegnati

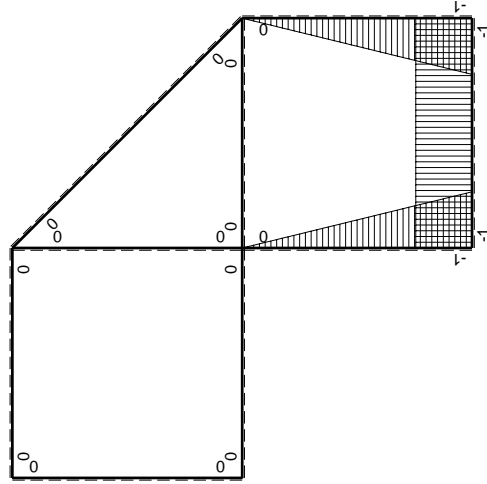

(\oplus) M_x flessione da iperstatica X=1

Quadro contribuiti PLV per iperstatica X=W_{CD}

→	$M_x(x)$	$M_0(x)$	$M_x M_0$	$M_x M_x$	$\int M_x M_0 / EJ dx$	$\int M_x M_x / EJ dx$
AB b	0	-5/2Fx	0	0	0	0
BA b	0	5/2Fb-5/2Fx	0	0	0	0
BC b	-x/b	-5/2Fb+3/2Fx	5/2Fx-3/2Fx ² /b	x ² /b ²	3/4Fb ² /EJ	1/3Xb/EJ
CB b	1-x/b	Fb+3/2Fx	Fb+1/2Fx-3/2Fx ² /b	1-2x/b+x ² /b ²		
CD b	-1	0	0	1	0	Xb/EJ
DC b	1	0	0	1	0	
DE b	-1+x/b	-3/2Fx	3/2Fx-3/2Fx ² /b	1-2x/b+x ² /b ²	1/4Fb ² /EJ	1/3Xb/EJ
ED b	x/b	3/2Fb-3/2Fx	3/2Fx-3/2Fx ² /b	x ² /b ²		
EF √2b	0	√2/2Fx	0	0	0	0
FG b	0	-3/2Fx+1/2qx ²	0	0	0	0
GF b	0	Fb-1/2Fx-1/2qx ²	0	0	0	0
GA b	0	0	0	0	0	0
AG b	0	0	0	0	0	0
FB b	0	Fb-Fx	0	0	0	0
BF b	0	-Fx	0	0	0	0
BE b	0	Fx-1/2qx ²	0	0	0	0
EB b	0	-1/2Fb+1/2qx ²	0	0	0	0
BE	elongazione asta $N_{1BE}^E - L_{BE}^E$				Fb ² /EJ	
	totali				2Fb ² /EJ	5/3Xb/EJ
	iperstatica X=W _{CD}				-6/5Fb	

Sviluppi di calcolo iperstatica

$$L_{BC}^{xx} = \int_0^b (x^2/b^2) 1/EJ dx = [1/3 x^3/b^2]_0^b 1/EJ$$

$$= (1/3 b) 1/EJ = 1/3 b/EJ$$

$$L_{CB}^{xx} = \int_0^b (1 - 2x/b + x^2/b^2) 1/EJ dx = [x - x^2/b + 1/3 x^3/b^2]_0^b 1/EJ$$

$$= (b - b + 1/3 b) 1/EJ = 1/3 b/EJ$$

$$L_{CD}^{xx} = \int_0^b (1) 1/EJ dx = [x]_0^b 1/EJ$$

$$= (b) 1/EJ = b/EJ$$

$$L_{DC}^{xx} = \int_0^b (1) 1/EJ dx = [x]_0^b 1/EJ$$

$$= (b) 1/EJ = b/EJ$$

$$L_{DE}^{xx} = \int_0^b (1 - 2x/b + x^2/b^2) 1/EJ dx = [x - x^2/b + 1/3 x^3/b^2]_0^b 1/EJ$$

$$= (b - b + 1/3 b) 1/EJ = 1/3 b/EJ$$

$$L_{ED}^{xx} = \int_0^b (x^2/b^2) 1/EJ dx = [1/3 x^3/b^2]_0^b 1/EJ$$

$$= (1/3 b) 1/EJ = 1/3 b/EJ$$

$$L_{BC}^{xo} = \int_0^b (5/2 x/b - 3/2 x^2/b^2) Fb 1/EJ dx = [5/4 x^2/b - 1/2 x^3/b^2]_0^b Fb 1/EJ$$

$$= (5/4 b - 1/2 b) Fb 1/EJ = 3/4 Fb^2/EJ$$

$$L_{CB}^{xo} = \int_0^b (1 + 1/2 x/b - 3/2 x^2/b^2) Fb 1/EJ dx = [x + 1/4 x^2/b - 1/2 x^3/b^2]_0^b Fb 1/EJ$$

$$= (b + 1/4 b - 1/2 b) Fb 1/EJ = 3/4 Fb^2/EJ$$

$$L_{DE}^{xo} = \int_0^b (3/2 x/b - 3/2 x^2/b^2) Fb 1/EJ dx = [3/4 x^2/b - 1/2 x^3/b^2]_0^b Fb 1/EJ$$

$$= (3/4 b - 1/2 b) Fb 1/EJ = 1/4 Fb^2/EJ$$

$$L_{ED}^{xo} = \int_0^b (3/2 x/b - 3/2 x^2/b^2) Fb 1/EJ dx = [3/4 x^2/b - 1/2 x^3/b^2]_0^b Fb 1/EJ$$

$$= (3/4 b - 1/2 b) Fb 1/EJ = 1/4 Fb^2/EJ$$

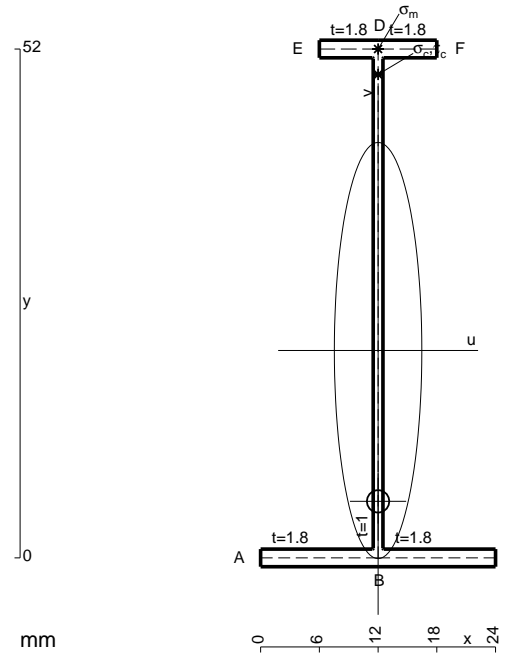

$A = 116.8 \text{ mm}^2$
 $J_u = 52822. \text{ mm}^4$
 $J_v = 2333. \text{ mm}^4$
 $J_t = 87.32 \text{ mm}^4$
 $y_o = -15.41 \text{ mm}$
 $y_g = 21.19 \text{ mm}$
 $N = -250. \text{ N}$
 $T_y = -625. \text{ N}$
 $M_x = -393750. \text{ Nmm}$
 $x_m = 12. \text{ mm}$
 $y_m = 52. \text{ mm}$
 $v_m = 30.81 \text{ mm}$
 $\sigma_m = N/A - Mv/J_u = 227.5 \text{ N/mm}^2$
 $y_c = 2. \text{ mm}$
 $u_c = -12. \text{ mm}$
 $v_c = -19.19 \text{ mm}$
 $\sigma_c = N/A - Mv/J_u = 227.5 \text{ N/mm}^2$
 $\tau_c = TS/tJ_u = 7.874 \text{ N/mm}^2$
 $\tau_g = TS/tJ_u = 7.874 \text{ N/mm}^2$
 $t_c = 250. \text{ mm}$
 $\sigma_o = \sqrt{\sigma^2 + 3\tau^2} = 227.9 \text{ N/mm}^2$

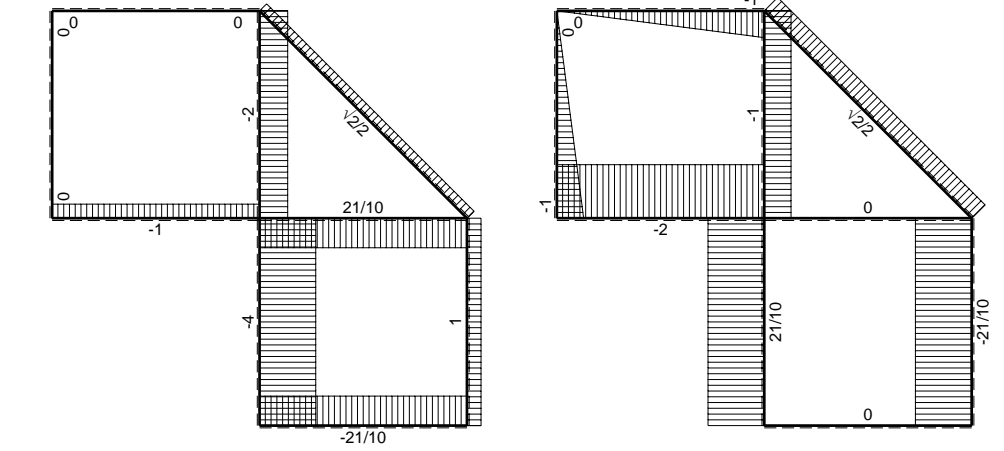
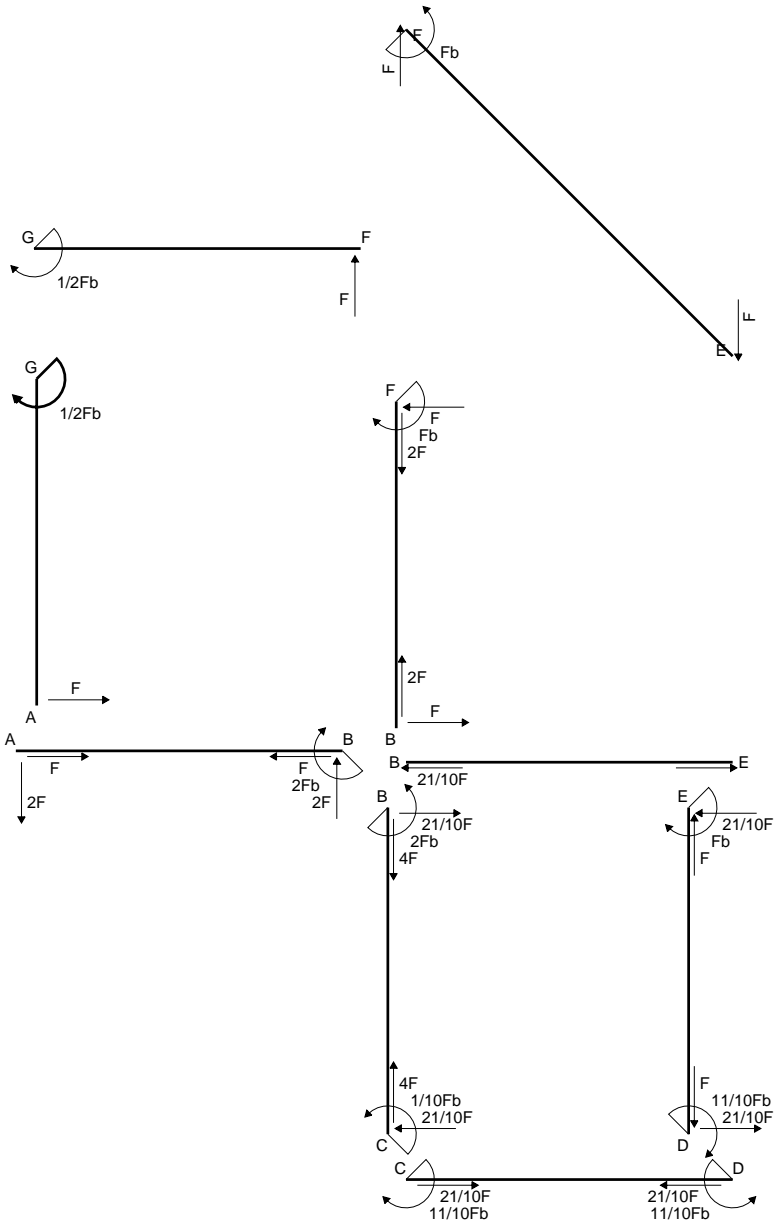

← ⊕ → F

↑ ⊕ ↓ F

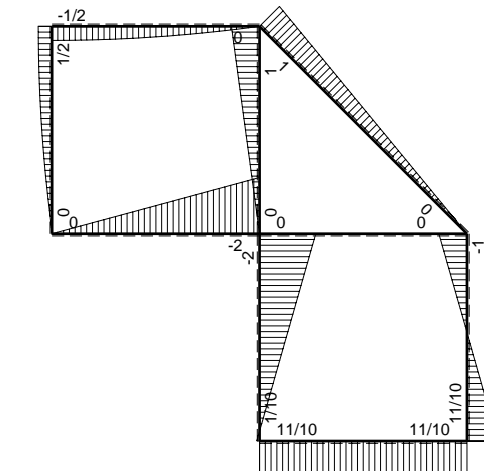

⊕ ↻ F_b

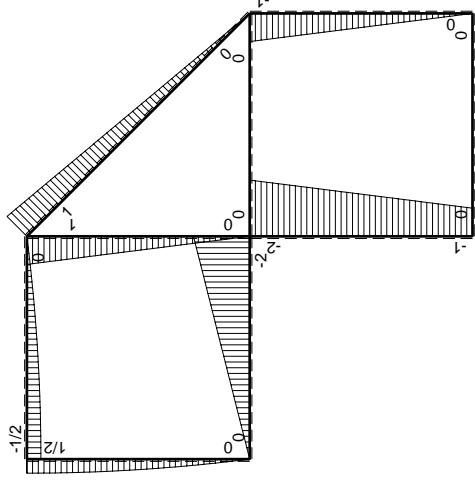
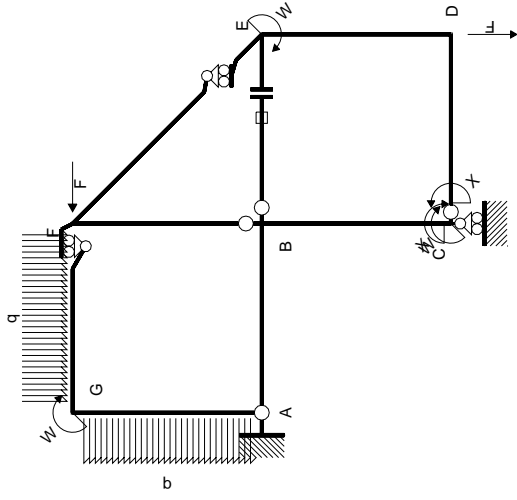

Schema di calcolo iperstatico

M_0 flessione da carichi assegnati

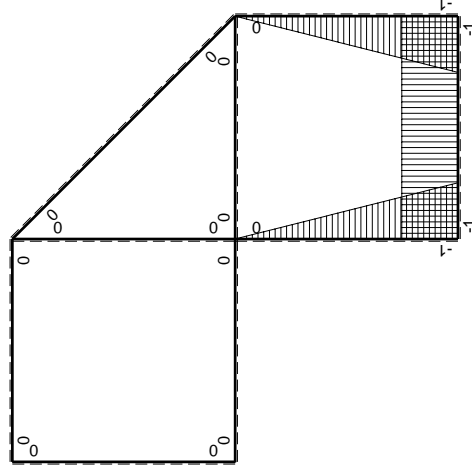

M_x flessione da iperstatica $X=1$

Quadro contribuiti PLV per iperstatica $X=W_{CD}$

\rightarrow	$M_x(x)$	$M_0(x)$	$M_x M_0$	$M_x M_x$	$\int M_x M_0 / EJ dx$	$\int M_x M_x / EJ dx$
AB b	0	-2Fx	0	0	0	0
BA b	0	2Fb-2Fx	0	0	0	0
BC b	-x/b	-2Fb+Fx	2Fx-Fx ² /b	x ² /b ²	2/3Fb ² /EJ	1/3Xb/EJ
CB b	1-x/b	Fb+Fx	Fb-Fx ² /b	1-2x/b+x ² /b ²		
CD b	-1	0	0	1	0	Xb/EJ
DC b	1	0	0	1	0	
DE b	-1+x/b	-Fx	Fx-Fx ² /b	1-2x/b+x ² /b ²	1/6Fb ² /EJ	1/3Xb/EJ
ED b	x/b	Fb-Fx	Fx-Fx ² /b	x ² /b ²		
EF $\sqrt{2}b$	0	$\sqrt{2}/2Fx$	0	0	0	0
FG b	0	-Fx+1/2qx ²	0	0	0	0
GF b	0	1/2Fb-1/2qx ²	0	0	0	0
GA b	0	1/2Fb-1/2qx ²	0	0	0	0
AG b	0	-Fx+1/2qx ²	0	0	0	0
FB b	0	Fb-Fx	0	0	0	0
BF b	0	-Fx	0	0	0	0
BE b	0	0	0	0	0	0
EB b	0	0	0	0	0	0
BE	elongazione asta $N_{1, BE} \epsilon_{BE} L_{BE}$				Fb ² /EJ	
	totali				11/6Fb ² /EJ	5/3Xb/EJ
	iperstatica $X=W_{CD}$				-11/10Fb	

Sviluppi di calcolo iperstatica

$$L_{BC}^{xx} = \int_0^b (x^2/b^2) 1/EJ dx = [1/3 x^3/b^2]_0^b 1/EJ$$

$$= (1/3 b) 1/EJ = 1/3 b/EJ$$

$$L_{CB}^{xx} = \int_0^b (1 - 2x/b + x^2/b^2) 1/EJ dx = [x - x^2/b + 1/3 x^3/b^2]_0^b 1/EJ$$

$$= (b - b + 1/3 b) 1/EJ = 1/3 b/EJ$$

$$L_{CD}^{xx} = \int_0^b (1) 1/EJ dx = [x]_0^b 1/EJ$$

$$= (b) 1/EJ = b/EJ$$

$$L_{DC}^{xx} = \int_0^b (1) 1/EJ dx = [x]_0^b 1/EJ$$

$$= (b) 1/EJ = b/EJ$$

$$L_{DE}^{xx} = \int_0^b (1 - 2x/b + x^2/b^2) 1/EJ dx = [x - x^2/b + 1/3 x^3/b^2]_0^b 1/EJ$$

$$= (b - b + 1/3 b) 1/EJ = 1/3 b/EJ$$

$$L_{ED}^{xx} = \int_0^b (x^2/b^2) 1/EJ dx = [1/3 x^3/b^2]_0^b 1/EJ$$

$$= (1/3 b) 1/EJ = 1/3 b/EJ$$

$$L_{BC}^{xo} = \int_0^b (2x/b - x^2/b^2) Fb 1/EJ dx = [x^2/b - 1/3 x^3/b^2]_0^b Fb 1/EJ$$

$$= (b - 1/3 b) Fb 1/EJ = 2/3 Fb^2/EJ$$

$$L_{CB}^{xo} = \int_0^b (1 - x^2/b^2) Fb 1/EJ dx = [x - 1/3 x^3/b^2]_0^b Fb 1/EJ$$

$$= (b - 1/3 b) Fb 1/EJ = 2/3 Fb^2/EJ$$

$$L_{DE}^{xo} = \int_0^b (x/b - x^2/b^2) Fb 1/EJ dx = [1/2 x^2/b - 1/3 x^3/b^2]_0^b Fb 1/EJ$$

$$= (1/2 b - 1/3 b) Fb 1/EJ = 1/6 Fb^2/EJ$$

$$L_{ED}^{xo} = \int_0^b (x/b - x^2/b^2) Fb 1/EJ dx = [1/2 x^2/b - 1/3 x^3/b^2]_0^b Fb 1/EJ$$

$$= (1/2 b - 1/3 b) Fb 1/EJ = 1/6 Fb^2/EJ$$

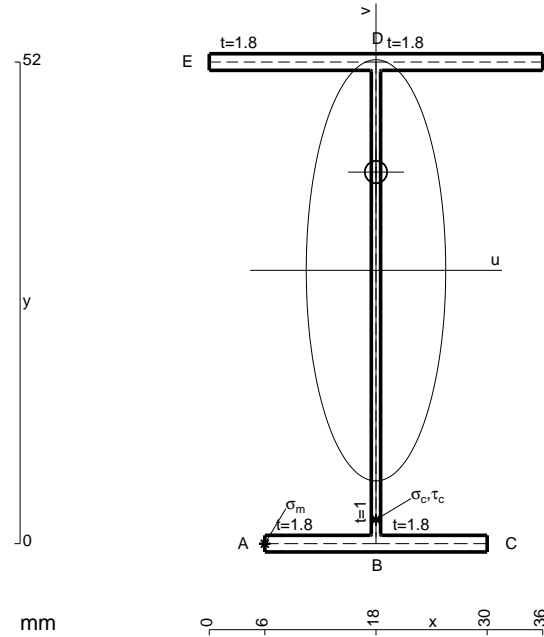

- A = 160. mm²
- J_u = 82754. mm⁴
- J_v = 9072. mm⁴
- J_i = 134. mm⁴
- y_o = 10.6 mm
- y_g = 29.51 mm
- N = -480. N
- T_y = -960. N
- M_x = -652800. Nmm
- x_m = 6. mm
- u_m = -12. mm
- v_m = -29.51 mm
- σ_m = N/A-Mv/J_u = -235.8 N/mm²
- x_c = 18. mm
- v_c = -29.51 mm
- σ_c = N/A-Mv/J_u = -235.8 N/mm²
- τ_c = TS^{*}/tJ_u = 14.79 N/mm²
- τ_g = TS^{*}/tJ_u = 14.79 N/mm²
- t_c = 480. mm
- σ_o = √σ²+3τ² = 237.2 N/mm²

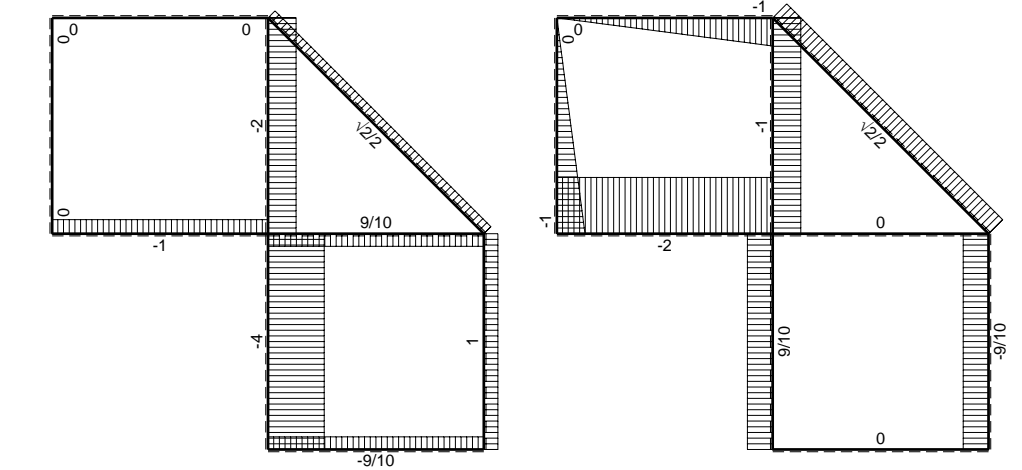
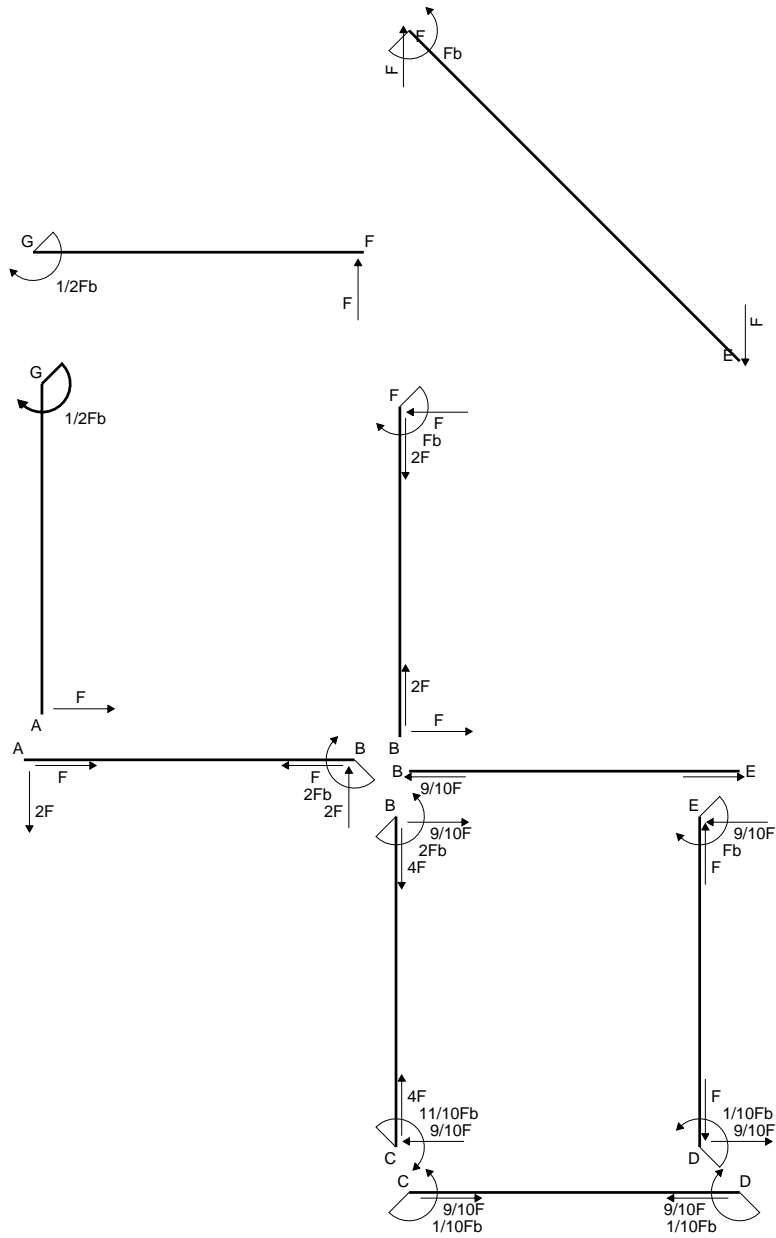

← ⊕ → F

↑ ⊕ ↓ F

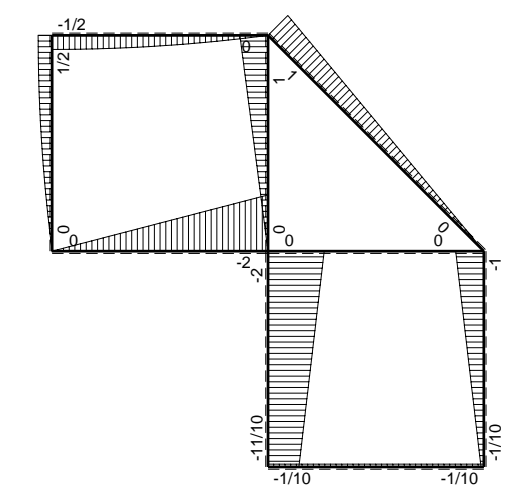

⊕ ⊖ Fb

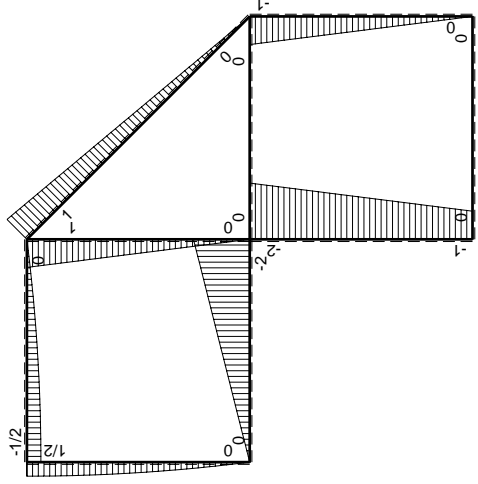
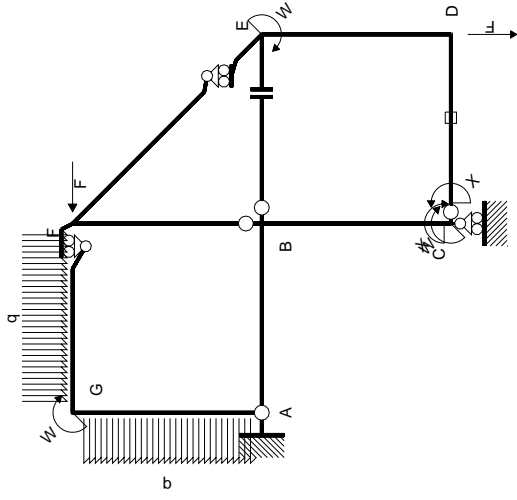

Schema di calcolo iperstatico

M_0 flessione da carichi assegnati

Quadro contribuiti PLV per iperstatica $X=W_{CD}$

\rightarrow	$M_x(x)$	$M_0(x)$	$M_x M_0$	$M_x M_x$	$\int M_x M_0 / EJ dx$	$\int X M_x M_x / EJ dx$
AB b	0	-2Fx	0	0	0	0
BA b	0	2Fb-2Fx	0	0	0	0
BC b	-x/b	-2Fb+Fx	$2Fx-Fx^2/b$	x^2/b^2	$2/3Fb^2/EJ$	$1/3Xb/EJ$
CB b	1-x/b	Fb+Fx	$Fb-Fx^2/b$	$1-2x/b+x^2/b^2$		
CD b	-1	0	0	1	0	Xb/EJ
DC b	1	0	0	1	0	
DE b	-1+x/b	-Fx	$Fx-Fx^2/b$	$1-2x/b+x^2/b^2$	$1/6Fb^2/EJ$	$1/3Xb/EJ$
ED b	x/b	Fb-Fx	$Fx-Fx^2/b$	x^2/b^2		
EF $\sqrt{2}b$	0	$\sqrt{2}/2Fx$	0	0	0	0
FG b	0	$-Fx+1/2qx^2$	0	0	0	0
GF b	0	$1/2Fb-1/2qx^2$	0	0	0	0
GA b	0	$1/2Fb-1/2qx^2$	0	0	0	0
AG b	0	$-Fx+1/2qx^2$	0	0	0	0
FB b	0	Fb-Fx	0	0	0	0
BF b	0	-Fx	0	0	0	0
BE b	0	0	0	0	0	0
EB b	0	0	0	0	0	0
CD	elongazione asta $N_{1,cd} \epsilon_{cd} L_{cd}$				$-Fb^2/EJ$	
	totali				$-1/6Fb^2/EJ$	$5/3Xb/EJ$
	iperstatica $X=W_{CD}$				$1/10Fb$	

Sviluppi di calcolo iperstatica

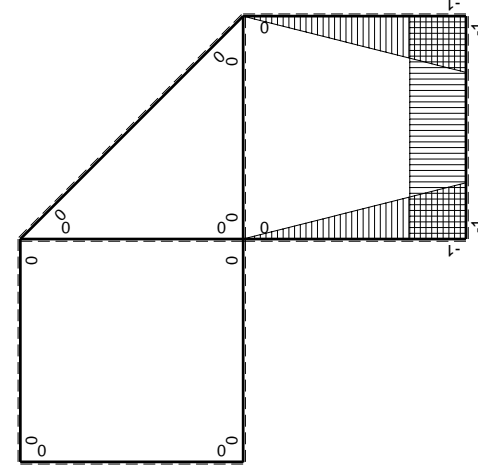

M_x flessione da iperstatica $X=1$

$$L_{BC}^{xx} = \int_0^b (x^2/b^2) 1/EJ dx = [1/3 x^3/b^2]_0^b 1/EJ$$

$$= (1/3 b) 1/EJ = 1/3 b/EJ$$

$$L_{CB}^{xx} = \int_0^b (1 - 2x/b + x^2/b^2) 1/EJ dx = [x - x^2/b + 1/3 x^3/b^2]_0^b 1/EJ$$

$$= (b - b + 1/3 b) 1/EJ = 1/3 b/EJ$$

$$L_{CD}^{xx} = \int_0^b (1) 1/EJ dx = [x]_0^b 1/EJ$$

$$= (b) 1/EJ = b/EJ$$

$$L_{DC}^{xx} = \int_0^b (1) 1/EJ dx = [x]_0^b 1/EJ$$

$$= (b) 1/EJ = b/EJ$$

$$L_{DE}^{xx} = \int_0^b (1 - 2x/b + x^2/b^2) 1/EJ dx = [x - x^2/b + 1/3 x^3/b^2]_0^b 1/EJ$$

$$= (b - b + 1/3 b) 1/EJ = 1/3 b/EJ$$

$$L_{ED}^{xx} = \int_0^b (x^2/b^2) 1/EJ dx = [1/3 x^3/b^2]_0^b 1/EJ$$

$$= (1/3 b) 1/EJ = 1/3 b/EJ$$

$$L_{BC}^{x_0} = \int_0^b (2x/b - x^2/b^2) Fb 1/EJ dx = [x^2/b - 1/3 x^3/b^2]_0^b Fb 1/EJ$$

$$= (b - 1/3 b) Fb 1/EJ = 2/3 Fb^2/EJ$$

$$L_{CB}^{x_0} = \int_0^b (1 - x^2/b^2) Fb 1/EJ dx = [x - 1/3 x^3/b^2]_0^b Fb 1/EJ$$

$$= (b - 1/3 b) Fb 1/EJ = 2/3 Fb^2/EJ$$

$$L_{DE}^{x_0} = \int_0^b (x/b - x^2/b^2) Fb 1/EJ dx = [1/2 x^2/b - 1/3 x^3/b^2]_0^b Fb 1/EJ$$

$$= (1/2 b - 1/3 b) Fb 1/EJ = 1/6 Fb^2/EJ$$

$$L_{ED}^{x_0} = \int_0^b (x/b - x^2/b^2) Fb 1/EJ dx = [1/2 x^2/b - 1/3 x^3/b^2]_0^b Fb 1/EJ$$

$$= (1/2 b - 1/3 b) Fb 1/EJ = 1/6 Fb^2/EJ$$

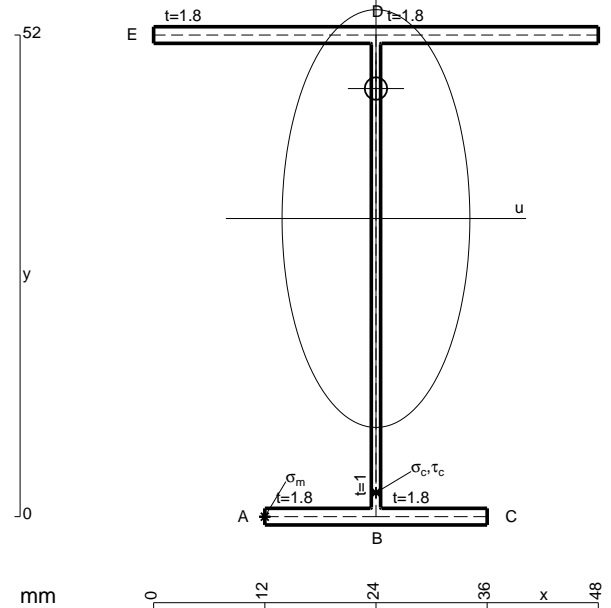

- A = 181.6 mm²
- J_u = 92380. mm⁴
- J_v = 18662. mm⁴
- J_I = 157.3 mm⁴
- y_o = 14.04 mm
- y_g = 32.19 mm
- N = -380. N
- T_y = -760. N
- M_x = -554800. Nmm
- x_m = 12. mm
- u_m = -12. mm
- v_m = -32.19 mm
- σ_m = N/A-Mv/J_u = -195.4 N/mm²
- x_c = 24. mm
- v_c = -32.19 mm
- σ_c = N/A-Mv/J_u = -195.4 N/mm²
- τ_c = TS^{*}/tJ_u = 11.44 N/mm²
- τ_g = TS^{*}/tJ_u = 11.44 N/mm²
- t_c = 380. mm
- σ_o = √σ²+3τ² = 196.4 N/mm²

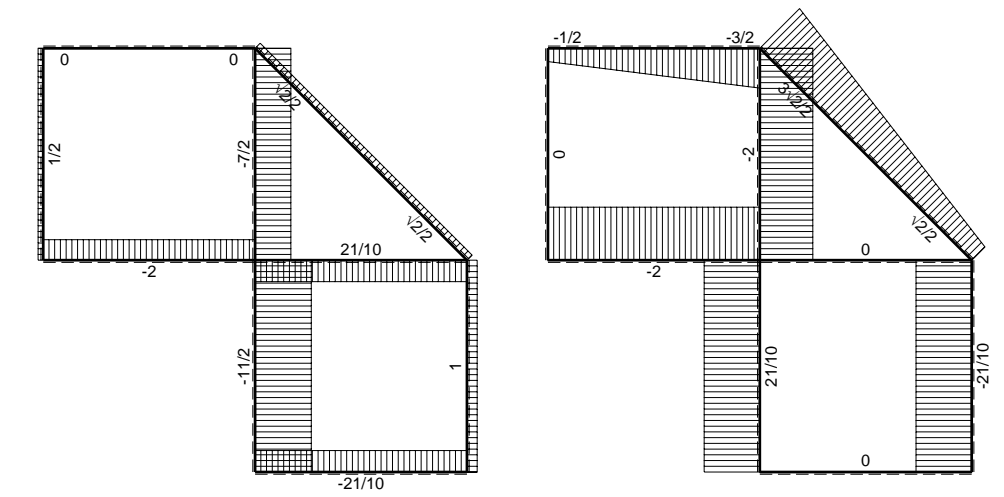
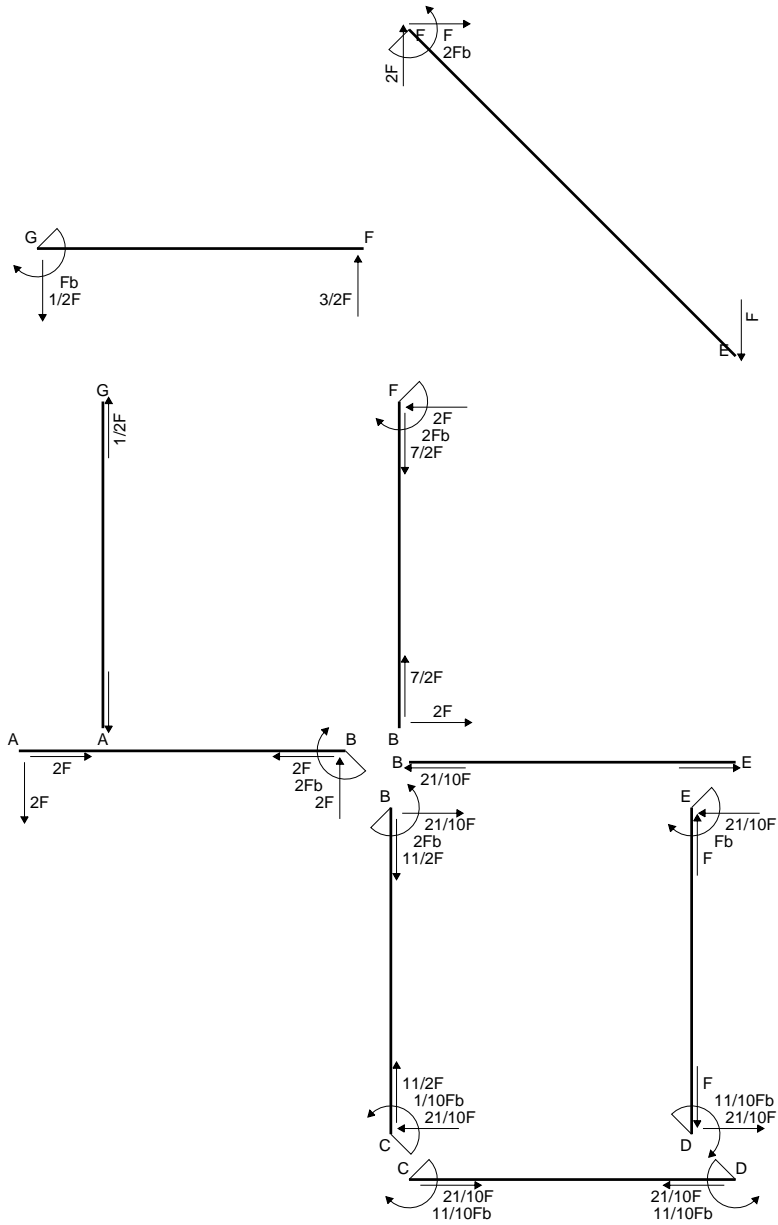

$\leftarrow \boxed{+} \rightarrow F$

$\uparrow \boxed{+} \downarrow F$

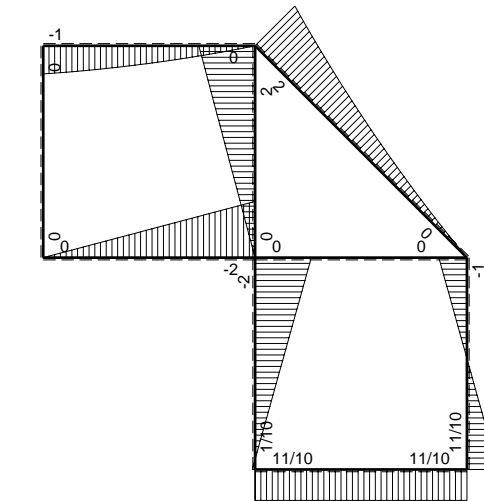

$\leftarrow \boxed{+} \rightarrow F_b$

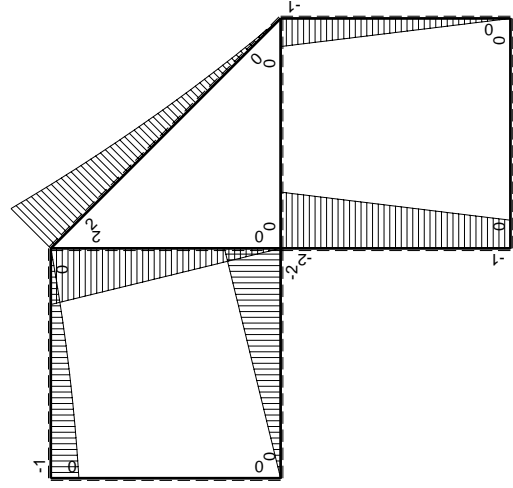
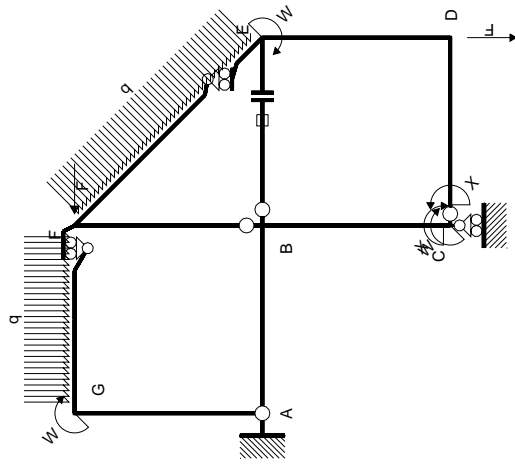

Schema di calcolo iperstatico

M_0 flessione da carichi assegnati

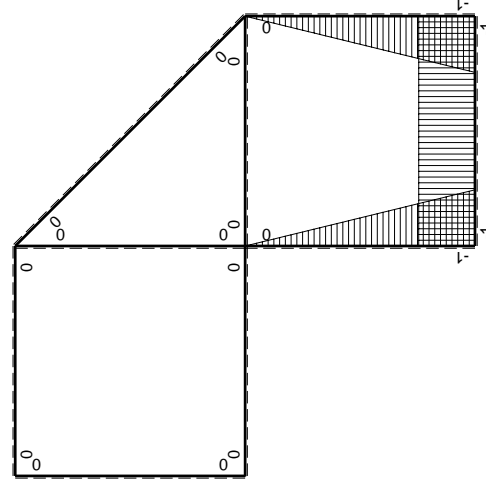

M_x flessione da iperstatica X=1

Quadro contribuiti PLV per iperstatica X=W_{CD}

→	$M_x(x)$	$M_0(x)$	$M_x M_0$	$M_x M_x$	$\int M_x M_0 / E J dx$	$\int X M_x M_x / E J dx$
AB b	0	-2Fx	0	0	0	0
BA b	0	2Fb-2Fx	0	0	0	0
BC b	-x/b	-2Fb+Fx	2Fx-Fx ² /b	x ² /b ²	2/3Fb ² /EJ	1/3Xb/EJ
CB b	1-x/b	Fb+Fx	Fb-Fx ² /b	1-2x/b+x ² /b ²		
CD b	-1	0	0	1	0	Xb/EJ
DC b	1	0	0	1	0	
DE b	-1+x/b	-Fx	Fx-Fx ² /b	1-2x/b+x ² /b ²	1/6Fb ² /EJ	1/3Xb/EJ
ED b	x/b	Fb-Fx	Fx-Fx ² /b	x ² /b ²		
EF √2b	0	√2/2Fx+1/2qx ²	0	0	0	0
FG b	0	-3/2Fx+1/2qx ²	0	0	0	0
GF b	0	Fb-1/2Fx-1/2qx ²	0	0	0	0
GA b	0	0	0	0	0	0
AG b	0	0	0	0	0	0
FB b	0	2Fb-2Fx	0	0	0	0
BF b	0	-2Fx	0	0	0	0
BE b	0	0	0	0	0	0
EB b	0	0	0	0	0	0
BE	elongazione asta $N_{1, BE} \epsilon_{BE} L_{BE}$				Fb ² /EJ	
	totali				11/6Fb ² /EJ	5/3Xb/EJ
	iperstatica X=W _{CD}				-11/10Fb	

Sviluppi di calcolo iperstatica

$$L_{BC}^{xx} = \int_0^b (x^2/b^2) 1/EJ dx = [1/3 x^3/b^2]_0^b 1/EJ$$

$$= (1/3 b) 1/EJ = 1/3 b/EJ$$

$$L_{CB}^{xx} = \int_0^b (1 - 2x/b + x^2/b^2) 1/EJ dx = [x - x^2/b + 1/3 x^3/b^2]_0^b 1/EJ$$

$$= (b - b + 1/3 b) 1/EJ = 1/3 b/EJ$$

$$L_{CD}^{xx} = \int_0^b (1) 1/EJ dx = [x]_0^b 1/EJ$$

$$= (b) 1/EJ = b/EJ$$

$$L_{DC}^{xx} = \int_0^b (1) 1/EJ dx = [x]_0^b 1/EJ$$

$$= (b) 1/EJ = b/EJ$$

$$L_{DE}^{xx} = \int_0^b (1 - 2x/b + x^2/b^2) 1/EJ dx = [x - x^2/b + 1/3 x^3/b^2]_0^b 1/EJ$$

$$= (b - b + 1/3 b) 1/EJ = 1/3 b/EJ$$

$$L_{ED}^{xx} = \int_0^b (x^2/b^2) 1/EJ dx = [1/3 x^3/b^2]_0^b 1/EJ$$

$$= (1/3 b) 1/EJ = 1/3 b/EJ$$

$$L_{BC}^{x_0} = \int_0^b (2x/b - x^2/b^2) Fb 1/EJ dx = [x^2/b - 1/3 x^3/b^2]_0^b Fb 1/EJ$$

$$= (b - 1/3 b) Fb 1/EJ = 2/3 Fb^2/EJ$$

$$L_{CB}^{x_0} = \int_0^b (1 - x^2/b^2) Fb 1/EJ dx = [x - 1/3 x^3/b^2]_0^b Fb 1/EJ$$

$$= (b - 1/3 b) Fb 1/EJ = 2/3 Fb^2/EJ$$

$$L_{DE}^{x_0} = \int_0^b (x/b - x^2/b^2) Fb 1/EJ dx = [1/2 x^2/b - 1/3 x^3/b^2]_0^b Fb 1/EJ$$

$$= (1/2 b - 1/3 b) Fb 1/EJ = 1/6 Fb^2/EJ$$

$$L_{ED}^{x_0} = \int_0^b (x/b - x^2/b^2) Fb 1/EJ dx = [1/2 x^2/b - 1/3 x^3/b^2]_0^b Fb 1/EJ$$

$$= (1/2 b - 1/3 b) Fb 1/EJ = 1/6 Fb^2/EJ$$

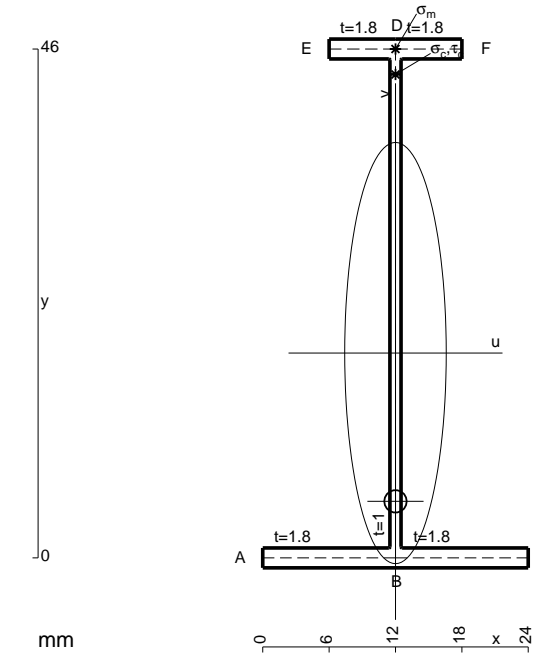

- A = 110.8 mm²
- J_u = 40163. mm⁴
- J_v = 2333. mm⁴
- J_I = 85.32 mm⁴
- y_o = -13.41 mm
- y_g = 18.52 mm
- N = 155.6 N
- T_y = 466.7 N
- M_x = 299200. Nmm
- x_m = 12. mm
- y_m = 46. mm
- v_m = 27.48 mm
- σ_m = N/A-Mv/J_u = -203.3 N/mm²
- y_c = 2. mm
- u_c = -12. mm
- v_c = -16.52 mm
- σ_c = N/A-Mv/J_u = -203.3 N/mm²
- τ_c = TS/tJ_u = 6.898 N/mm²
- τ_g = TS/tJ_u = 6.898 N/mm²
- t_c = 220. mm
- σ_o = √σ²+3τ² = 203.7 N/mm²

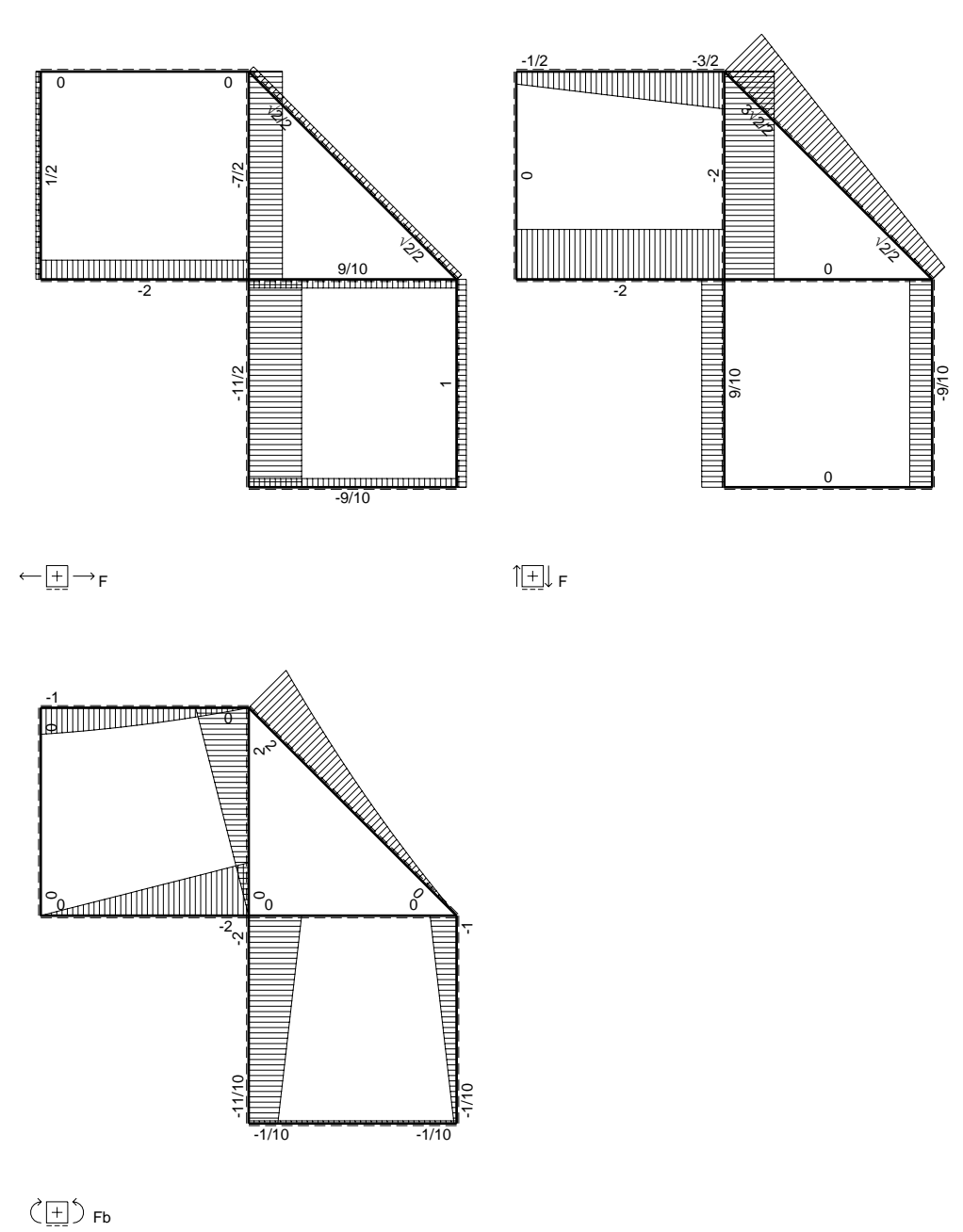
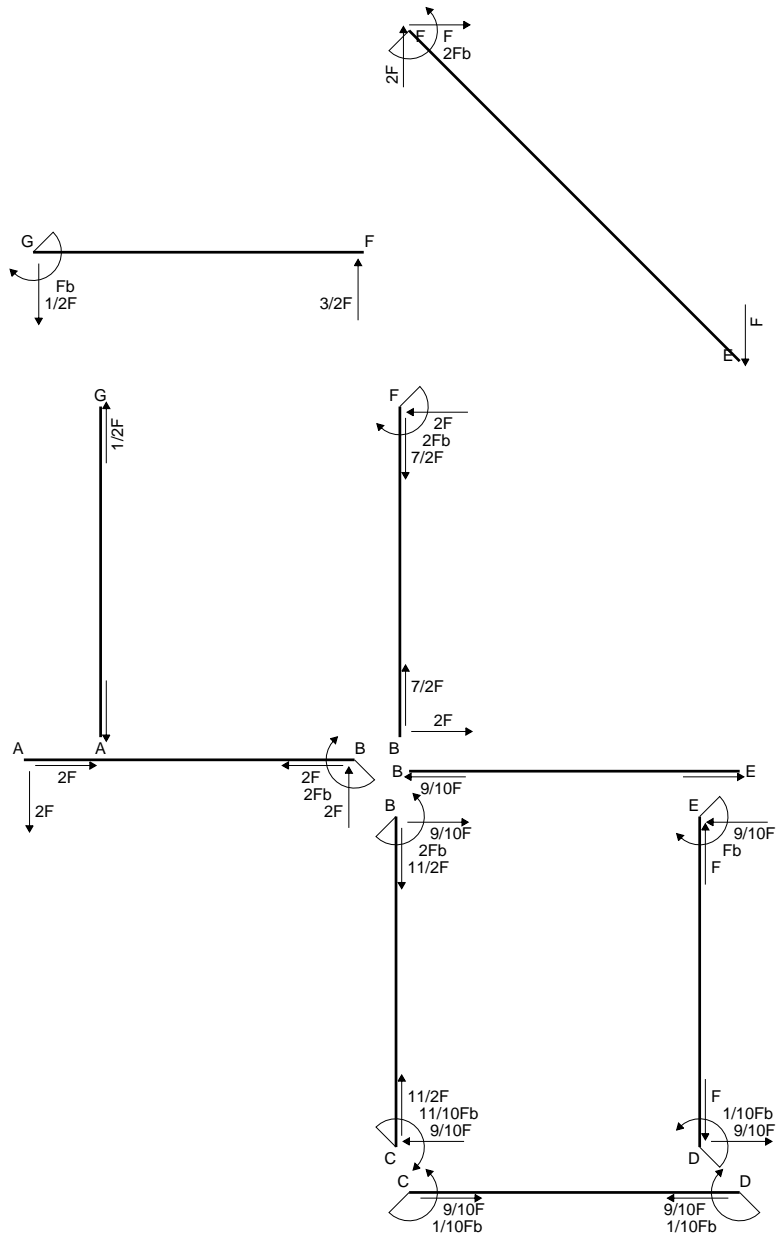

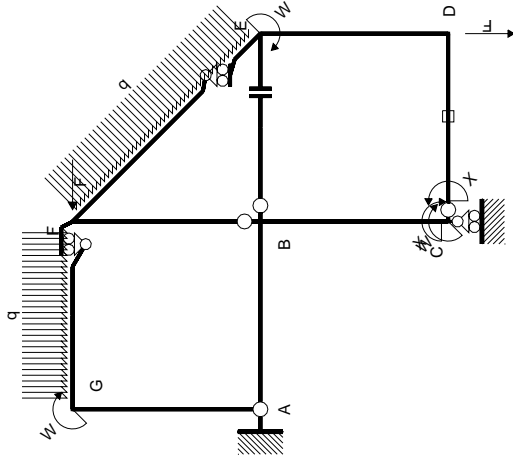

Schema di calcolo iperstatico

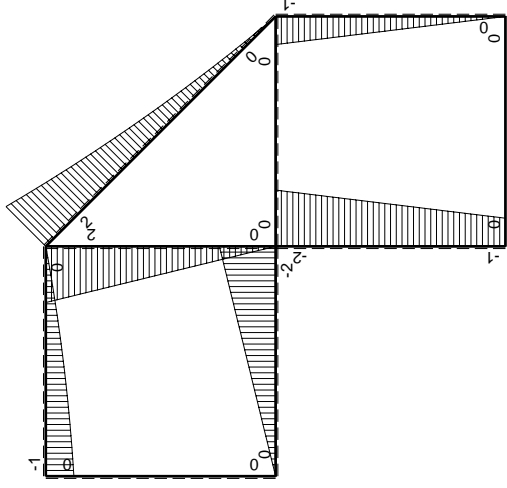

M_0 flessione da carichi assegnati

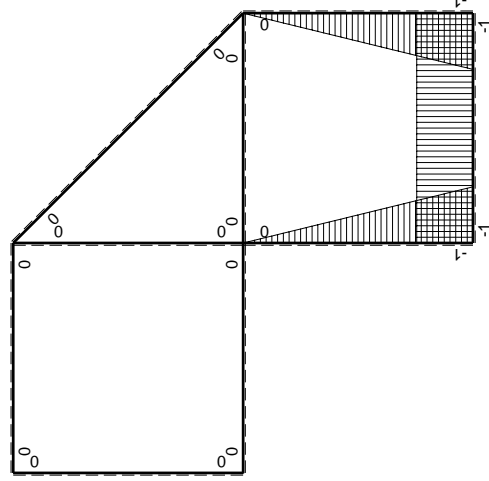

M_x flessione da iperstatica X=1

Quadro contributi PLV per iperstatica X=W_{cd}

→	$M_x(x)$	$M_0(x)$	$M_x M_0$	$M_x M_x$	$\int M_x M_0 / E J dx$	$\int X M_x M_x / E J dx$
AB b	0	-2Fx	0	0	0	0
BA b	0	2Fb-2Fx	0	0	0	0
BC b	-x/b	-2Fb+Fx	2Fx-Fx ² /b	x ² /b ²	2/3Fb ² /EJ	1/3Xb/EJ
CB b	1-x/b	Fb+Fx	Fb-Fx ² /b	1-2x/b+x ² /b ²		
CD b	-1	0	0	1	0	Xb/EJ
DC b	1	0	0	1	0	
DE b	-1+x/b	-Fx	Fx-Fx ² /b	1-2x/b+x ² /b ²	1/6Fb ² /EJ	1/3Xb/EJ
ED b	x/b	Fb-Fx	Fx-Fx ² /b	x ² /b ²		
EF √2b	0	√2/2Fx+1/2qx ²	0	0	0	0
FG b	0	-3/2Fx+1/2qx ²	0	0	0	0
GF b	0	Fb-1/2Fx-1/2qx ²	0	0	0	0
GA b	0	0	0	0	0	0
AG b	0	0	0	0	0	0
FB b	0	2Fb-2Fx	0	0	0	0
BF b	0	-2Fx	0	0	0	0
BE b	0	0	0	0	0	0
EB b	0	0	0	0	0	0
CD	elongazione asta N _{1,cd} ε _{cd} L _{cd}				-Fb ² /EJ	
	totali				-1/6Fb ² /EJ	5/3Xb/EJ
	iperstatica X=W _{cd}				1/10Fb	

Sviluppi di calcolo iperstatica

$$L_{BC}^{xx} = \int_0^b (x^2/b^2) 1/EJ dx = [1/3 x^3/b^2]_0^b 1/EJ$$

$$= (1/3 b) 1/EJ = 1/3 b/EJ$$

$$L_{CB}^{xx} = \int_0^b (1 - 2x/b + x^2/b^2) 1/EJ dx = [x - x^2/b + 1/3 x^3/b^2]_0^b 1/EJ$$

$$= (b - b + 1/3 b) 1/EJ = 1/3 b/EJ$$

$$L_{CD}^{xx} = \int_0^b (1) 1/EJ dx = [x]_0^b 1/EJ$$

$$= (b) 1/EJ = b/EJ$$

$$L_{DC}^{xx} = \int_0^b (1) 1/EJ dx = [x]_0^b 1/EJ$$

$$= (b) 1/EJ = b/EJ$$

$$L_{DE}^{xx} = \int_0^b (1 - 2x/b + x^2/b^2) 1/EJ dx = [x - x^2/b + 1/3 x^3/b^2]_0^b 1/EJ$$

$$= (b - b + 1/3 b) 1/EJ = 1/3 b/EJ$$

$$L_{ED}^{xx} = \int_0^b (x^2/b^2) 1/EJ dx = [1/3 x^3/b^2]_0^b 1/EJ$$

$$= (1/3 b) 1/EJ = 1/3 b/EJ$$

$$L_{BC}^{xo} = \int_0^b (2x/b - x^2/b^2) Fb 1/EJ dx = [x^2/b - 1/3 x^3/b^2]_0^b Fb 1/EJ$$

$$= (b - 1/3 b) Fb 1/EJ = 2/3 Fb^2/EJ$$

$$L_{CB}^{xo} = \int_0^b (1 - x^2/b^2) Fb 1/EJ dx = [x - 1/3 x^3/b^2]_0^b Fb 1/EJ$$

$$= (b - 1/3 b) Fb 1/EJ = 2/3 Fb^2/EJ$$

$$L_{DE}^{xo} = \int_0^b (x/b - x^2/b^2) Fb 1/EJ dx = [1/2 x^2/b - 1/3 x^3/b^2]_0^b Fb 1/EJ$$

$$= (1/2 b - 1/3 b) Fb 1/EJ = 1/6 Fb^2/EJ$$

$$L_{ED}^{xo} = \int_0^b (x/b - x^2/b^2) Fb 1/EJ dx = [1/2 x^2/b - 1/3 x^3/b^2]_0^b Fb 1/EJ$$

$$= (1/2 b - 1/3 b) Fb 1/EJ = 1/6 Fb^2/EJ$$

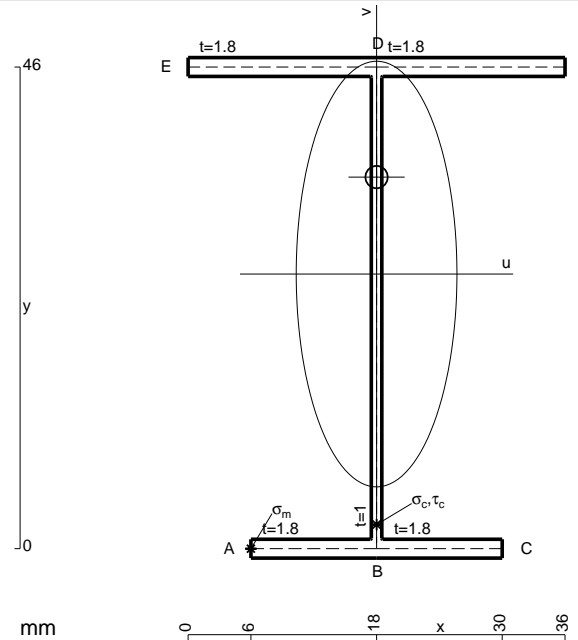

- A = 154. mm²
- J_u = 63641. mm⁴
- J_v = 9072. mm⁴
- J_t = 132. mm⁴
- y_o = 9.26 mm
- y_g = 26.23 mm
- N = 254.6 N
- T_y = 763.7 N
- M_x = 525600. Nmm
- x_m = 6. mm
- u_m = -12. mm
- v_m = -26.23 mm
- σ_m = N/A-Mv/J_u = 218.3 N/mm²
- x_c = 18. mm
- v_c = -26.23 mm
- σ_c = N/A-Mv/J_u = 218.3 N/mm²
- τ_c = TS_v/tJ_u = 13.6 N/mm²
- τ_g = TS_v/tJ_u = 13.6 N/mm²
- t_c = 360. mm
- σ_o = √σ²+3τ² = 219.5 N/mm²

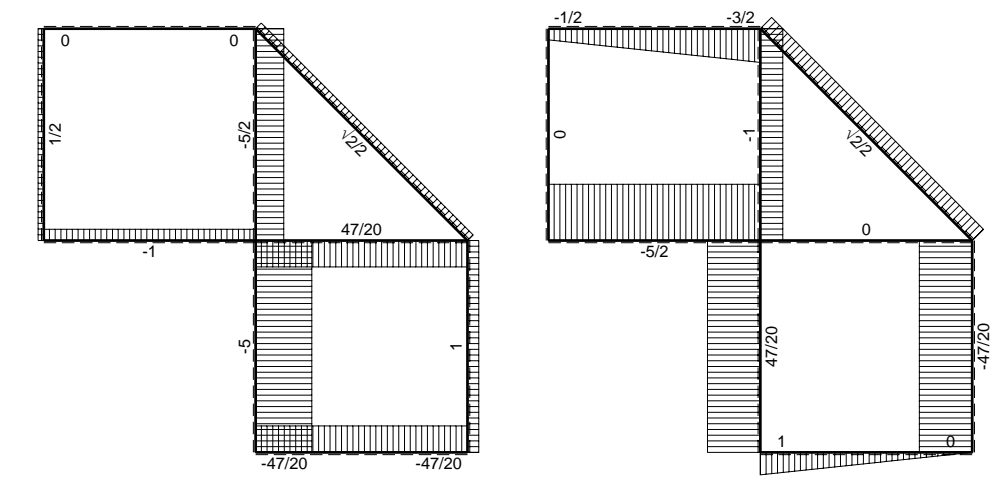
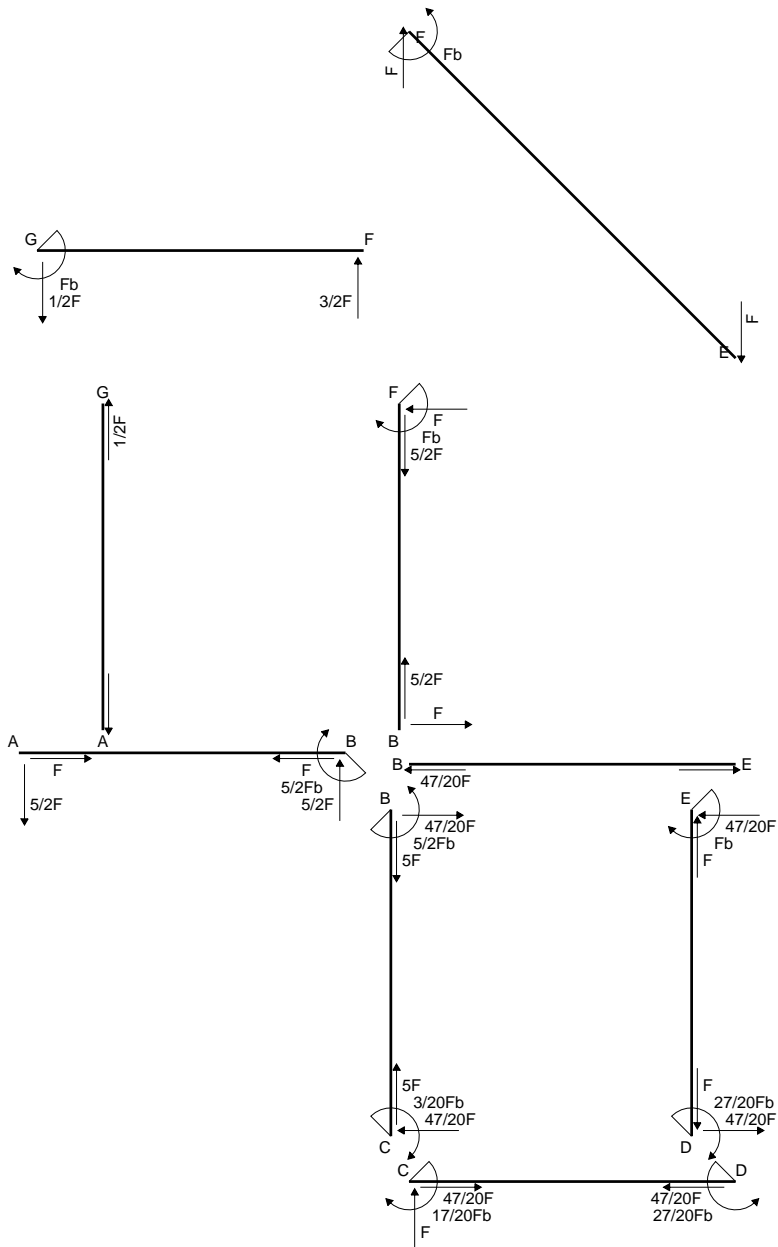

← ⊕ → F

↑ ⊕ ↓ F

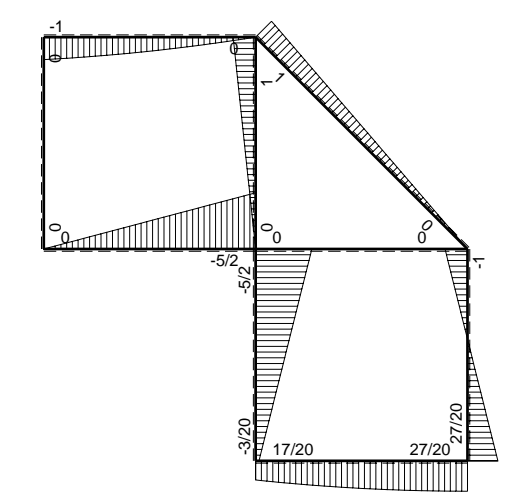

⊕ ⊖ Fb

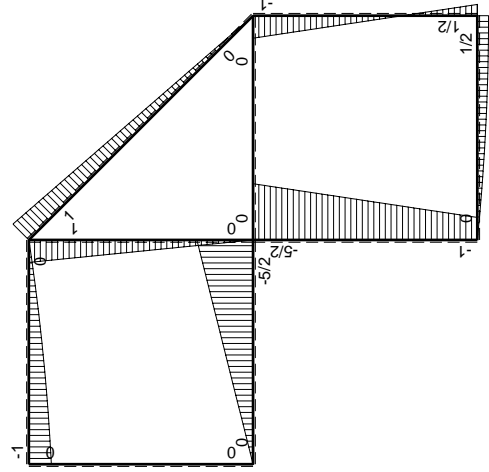
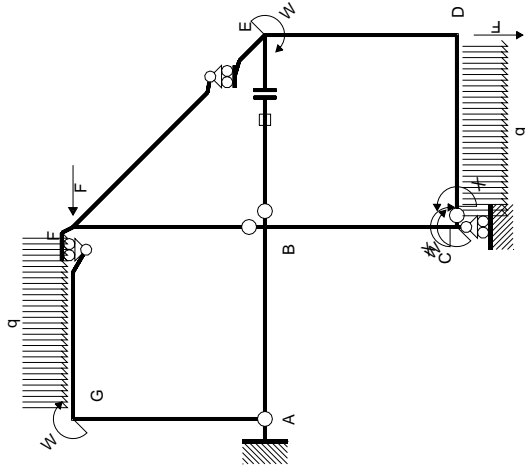

Schema di calcolo iperstatico

M_0 flessione da carichi assegnati

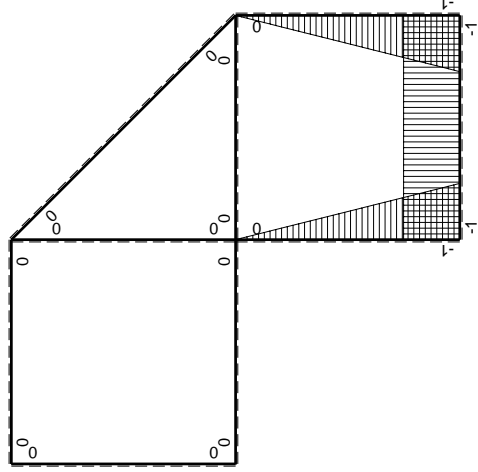

M_x flessione da iperstatica X=1

Quadro contribuiti PLV per iperstatica X=W_{CD}

→	$M_x(x)$	$M_0(x)$	$M_x M_0$	$M_x M_x$	$\int M_x M_0 / EJ dx$	$\int M_x M_x / EJ dx$
AB b	0	-5/2Fx	0	0	0	0
BA b	0	5/2Fb-5/2Fx	0	0	0	0
BC b	-x/b	-5/2Fb+3/2Fx	5/2Fx-3/2Fx ² /b	x ² /b ²	3/4Fb ² /EJ	1/3Xb/EJ
CB b	1-x/b	Fb+3/2Fx	Fb+1/2Fx-3/2Fx ² /b	1-2x/b+x ² /b ²	-1/3Fb ² /EJ	Xb/EJ
CD b	-1	Fx-1/2qx ²	-Fx+1/2Fx ² /b	1		
DC b	1	-1/2Fb+1/2qx ²	-1/2Fb+1/2Fx ² /b	1		
DE b	-1+x/b	1/2Fb-3/2Fx	-1/2Fb+2Fx-3/2Fx ² /b	1-2x/b+x ² /b ²	0	1/3Xb/EJ
ED b	x/b	Fb-3/2Fx	Fx-3/2Fx ² /b	x ² /b ²	0	0
EF √2b	0	√2/2Fx	0	0	0	0
FG b	0	-3/2Fx+1/2qx ²	0	0	0	0
GF b	0	Fb-1/2Fx-1/2qx ²	0	0	0	0
GA b	0	0	0	0	0	0
AG b	0	0	0	0	0	0
FB b	0	Fb-Fx	0	0	0	0
BF b	0	-Fx	0	0	0	0
BE b	0	0	0	0	0	0
EB b	0	0	0	0	0	0
BE	elongazione asta $N_{1, BE} \epsilon_{BE} = l_{BE}$				Fb ² /EJ	
	totali				17/12Fb ² /EJ	5/3Xb/EJ
	iperstatica X=W _{CD}				-17/20Fb	

Sviluppi di calcolo iperstatica

$$L_{BC}^{xx} = \int_0^b (x^2/b^2) 1/EJ dx = [1/3 x^3/b^2]_0^b 1/EJ$$

$$= (1/3 b) 1/EJ = 1/3 b/EJ$$

$$L_{CB}^{xx} = \int_0^b (1 - 2x/b + x^2/b^2) 1/EJ dx = [x - x^2/b + 1/3 x^3/b^2]_0^b 1/EJ$$

$$= (b - b + 1/3 b) 1/EJ = 1/3 b/EJ$$

$$L_{CD}^{xx} = \int_0^b (1) 1/EJ dx = [x]_0^b 1/EJ$$

$$= (b) 1/EJ = b/EJ$$

$$L_{DC}^{xx} = \int_0^b (1) 1/EJ dx = [x]_0^b 1/EJ$$

$$= (b) 1/EJ = b/EJ$$

$$L_{DE}^{xx} = \int_0^b (1 - 2x/b + x^2/b^2) 1/EJ dx = [x - x^2/b + 1/3 x^3/b^2]_0^b 1/EJ$$

$$= (b - b + 1/3 b) 1/EJ = 1/3 b/EJ$$

$$L_{ED}^{xx} = \int_0^b (x^2/b^2) 1/EJ dx = [1/3 x^3/b^2]_0^b 1/EJ$$

$$= (1/3 b) 1/EJ = 1/3 b/EJ$$

$$L_{BC}^{x_0} = \int_0^b (5/2 x/b - 3/2 x^2/b^2) Fb 1/EJ dx = [5/4 x^2/b - 1/2 x^3/b^2]_0^b Fb 1/EJ$$

$$= (5/4 b - 1/2 b) Fb 1/EJ = 3/4 Fb^2/EJ$$

$$L_{CB}^{x_0} = \int_0^b (1 + 1/2 x/b - 3/2 x^2/b^2) Fb 1/EJ dx = [x + 1/4 x^2/b - 1/2 x^3/b^2]_0^b Fb 1/EJ$$

$$= (b + 1/4 b - 1/2 b) Fb 1/EJ = 3/4 Fb^2/EJ$$

$$L_{CD}^{x_0} = \int_0^b (-x/b + 1/2 x^2/b^2) Fb 1/EJ dx = [-1/2 x^2/b + 1/6 x^3/b^2]_0^b Fb 1/EJ$$

$$= (-1/2 b + 1/6 b) Fb 1/EJ = -1/3 Fb^2/EJ$$

$$L_{DC}^{x_0} = \int_0^b (-1/2 + 1/2 x^2/b^2) Fb 1/EJ dx = [-1/2 x + 1/6 x^3/b^2]_0^b Fb 1/EJ$$

$$= (-1/2 b + 1/6 b) Fb 1/EJ = -1/3 Fb^2/EJ$$

$$L_{DE}^{x_0} = \int_0^b (-1/2 + 2x/b - 3/2 x^2/b^2) Fb 1/EJ dx = [-1/2 x + x^2/b - 1/2 x^3/b^2]_0^b Fb 1/EJ$$

$$= (-1/2 b + b - 1/2 b) Fb 1/EJ = 0$$

$$L_{ED}^{x_0} = \int_0^b (x/b - 3/2 x^2/b^2) Fb 1/EJ dx = [1/2 x^2/b - 1/2 x^3/b^2]_0^b Fb 1/EJ$$

$$= (1/2 b - 1/2 b) Fb 1/EJ = 0$$

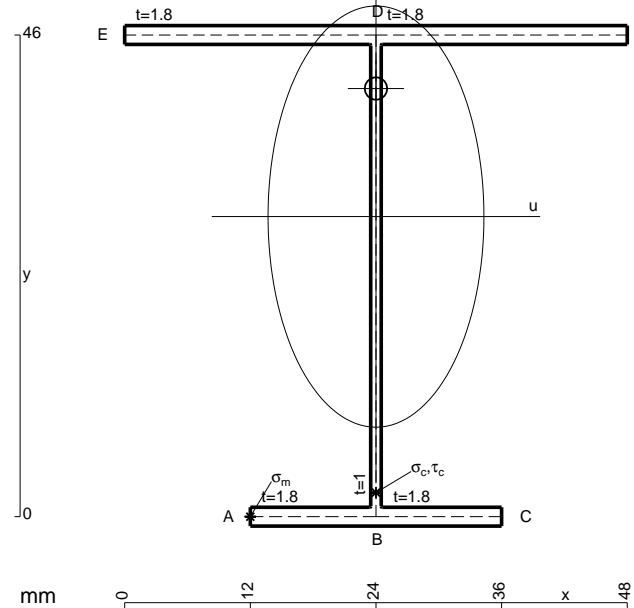

- A = 175.6 mm²
- J_u = 71048. mm⁴
- J_v = 18662. mm⁴
- J_I = 155.3 mm⁴
- y_o = 12.23 mm
- y_g = 28.66 mm
- N = -290. N
- T_y = -725. N
- M_x = -558250. Nmm
- x_m = 12. mm
- u_m = -12. mm
- v_m = -28.66 mm
- σ_m = N/A-Mv/J_u = -226.8 N/mm²
- x_c = 24. mm
- v_c = -28.66 mm
- σ_c = N/A-Mv/J_u = -226.8 N/mm²
- τ_c = TS_v/tJ_u = 12.63 N/mm²
- τ_g = TS_v/tJ_u = 12.63 N/mm²
- t_c = 290. mm
- σ_o = √σ²+3τ² = 227.9 N/mm²

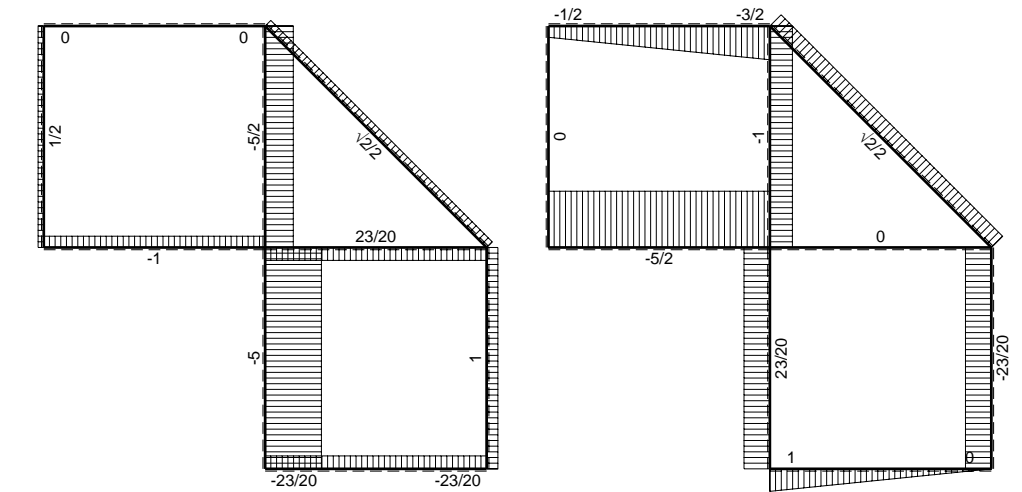
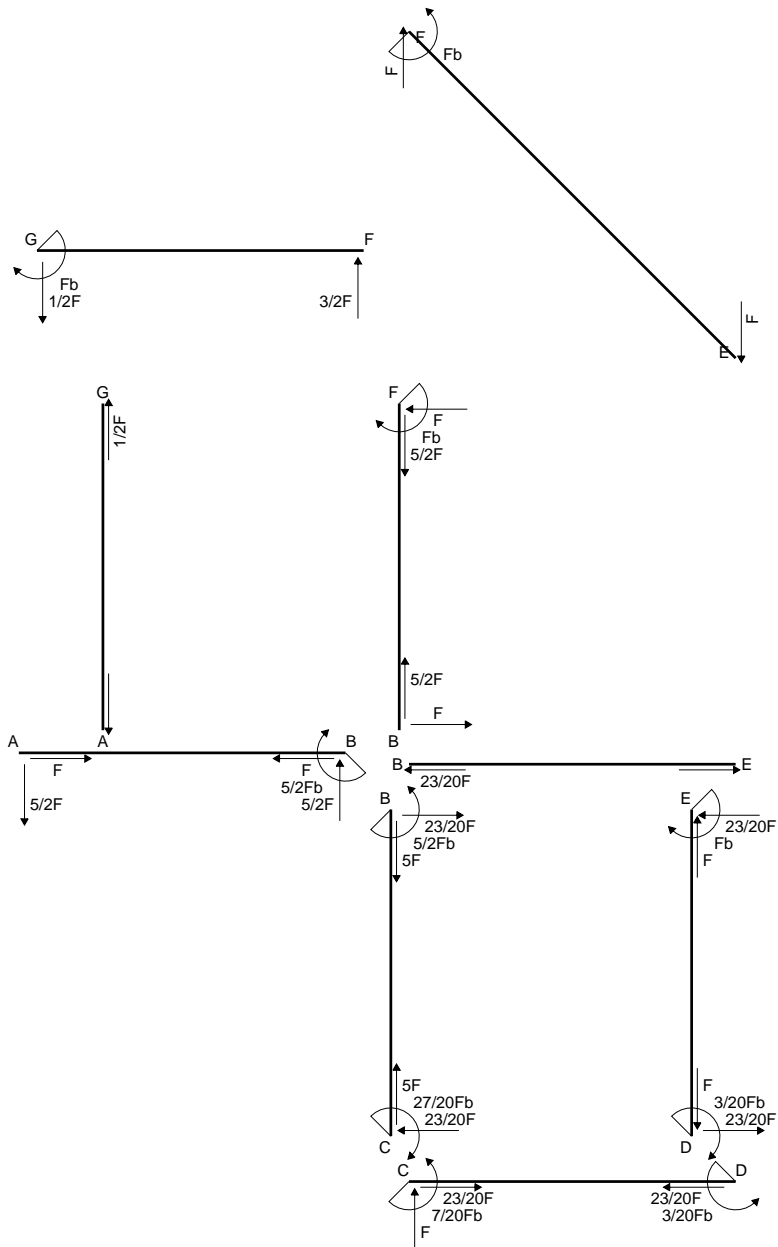

← ⊕ → F

↑ ⊕ ↓ F_b

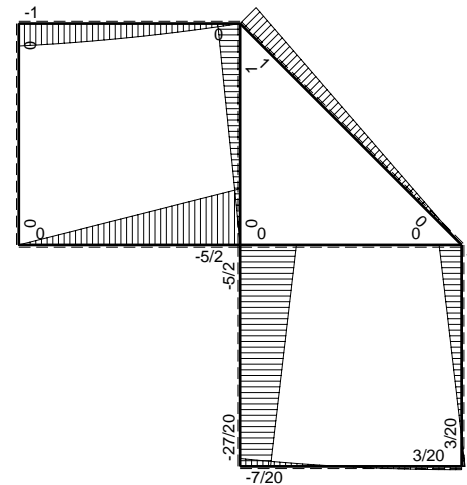

⊕ ⊖ F_b

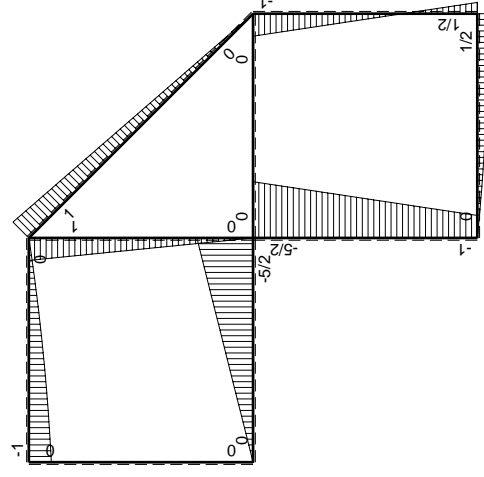
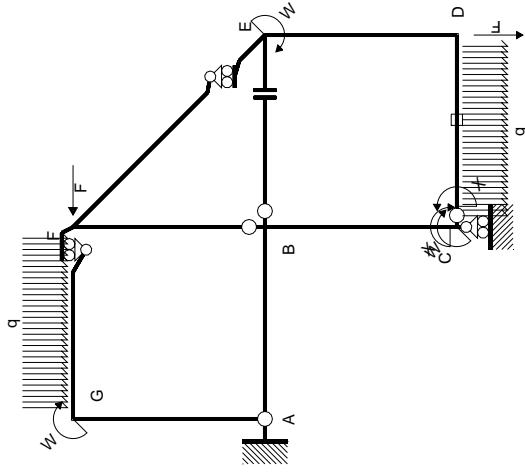

Schema di calcolo iperstatico

M_0 flessione da carichi assegnati

M_x flessione da iperstatica $X=1$

Quadro contribuiti PLV per iperstatica $X=W_{cd}$

\rightarrow	$M_x(x)$	$M_0(x)$	$M_x M_0$	$M_x M_x$	$\int M_x M_0 / EJ dx$	$\int M_x M_x / EJ dx$
AB b	0	-5/2Fx	0	0	0	0
BA b	0	5/2Fb-5/2Fx	0	0	0	0
BC b	-x/b	-5/2Fb+3/2Fx	5/2Fx-3/2Fx ² /b	x ² /b ²	3/4Fb ² /EJ	1/3Xb/EJ
CB b	1-x/b	Fb+3/2Fx	Fb+1/2Fx-3/2Fx ² /b	1-2x/b+x ² /b ²	-1/3Fb ² /EJ	Xb/EJ
CD b	-1	Fx-1/2qx ²	-Fx+1/2Fx ² /b	1	-1/3Fb ² /EJ	Xb/EJ
DC b	1	-1/2Fb+1/2qx ²	-1/2Fb+1/2Fx ² /b	1	-1/3Fb ² /EJ	Xb/EJ
DE b	-1+x/b	1/2Fb-3/2Fx	-1/2Fb+2Fx-3/2Fx ² /b	1-2x/b+x ² /b ²	0	1/3Xb/EJ
ED b	x/b	Fb-3/2Fx	Fx-3/2Fx ² /b	x ² /b ²	0	1/3Xb/EJ
EF $\sqrt{2}b$	0	$\sqrt{2}/2Fx$	0	0	0	0
FG b	0	-3/2Fx+1/2qx ²	0	0	0	0
GF b	0	Fb-1/2Fx-1/2qx ²	0	0	0	0
GA b	0	0	0	0	0	0
AG b	0	0	0	0	0	0
FB b	0	Fb-Fx	0	0	0	0
BF b	0	-Fx	0	0	0	0
BE b	0	0	0	0	0	0
EB b	0	0	0	0	0	0
CD	elongazione asta $N_{1,cd} \epsilon_{cd} L_{cd}$				-Fb ² /EJ	
	totali				-7/12Fb ² /EJ	5/3Xb/EJ
	iperstatica $X=W_{cd}$				7/20Fb	

Sviluppi di calcolo iperstatica

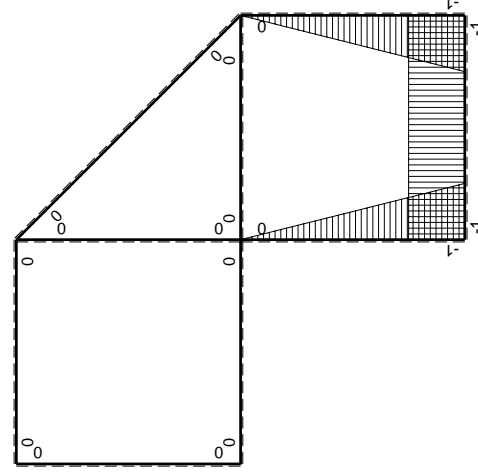

M_x flessione da iperstatica $X=1$

$$L_{BC}^{xx} = \int_0^b (x^2/b^2) 1/EJ dx = [1/3 x^3/b^2]_0^b 1/EJ$$

$$= (1/3 b) 1/EJ = 1/3 b/EJ$$

$$L_{CB}^{xx} = \int_0^b (1 - 2x/b + x^2/b^2) 1/EJ dx = [x - x^2/b + 1/3 x^3/b^2]_0^b 1/EJ$$

$$= (b - b + 1/3 b) 1/EJ = 1/3 b/EJ$$

$$L_{CD}^{xx} = \int_0^b (1) 1/EJ dx = [x]_0^b 1/EJ$$

$$= (b) 1/EJ = b/EJ$$

$$L_{DC}^{xx} = \int_0^b (1) 1/EJ dx = [x]_0^b 1/EJ$$

$$= (b) 1/EJ = b/EJ$$

$$L_{DE}^{xx} = \int_0^b (1 - 2x/b + x^2/b^2) 1/EJ dx = [x - x^2/b + 1/3 x^3/b^2]_0^b 1/EJ$$

$$= (b - b + 1/3 b) 1/EJ = 1/3 b/EJ$$

$$L_{ED}^{xx} = \int_0^b (x^2/b^2) 1/EJ dx = [1/3 x^3/b^2]_0^b 1/EJ$$

$$= (1/3 b) 1/EJ = 1/3 b/EJ$$

$$L_{BC}^{xo} = \int_0^b (5/2 x/b - 3/2 x^2/b^2) Fb 1/EJ dx = [5/4 x^2/b - 1/2 x^3/b^2]_0^b Fb 1/EJ$$

$$= (5/4 b - 1/2 b) Fb 1/EJ = 3/4 Fb^2/EJ$$

$$L_{CB}^{xo} = \int_0^b (1 + 1/2 x/b - 3/2 x^2/b^2) Fb 1/EJ dx = [x + 1/4 x^2/b - 1/2 x^3/b^2]_0^b Fb 1/EJ$$

$$= (b + 1/4 b - 1/2 b) Fb 1/EJ = 3/4 Fb^2/EJ$$

$$L_{CD}^{xo} = \int_0^b (-x/b + 1/2 x^2/b^2) Fb 1/EJ dx + 1 (-1) 1 Fb^2/EJ$$

$$= [-1/2 x^2/b + 1/6 x^3/b^2]_0^b Fb 1/EJ + 1 (-1) 1 Fb^2/EJ$$

$$= (-1/2 b + 1/6 b) Fb 1/EJ + 1 (-1) 1 Fb^2/EJ = -4/3 Fb^2/EJ$$

$$L_{DC}^{xo} = \int_0^b (-1/2 + 1/2 x^2/b^2) Fb 1/EJ dx + 1 (-1) 1 Fb^2/EJ$$

$$= [-1/2 x + 1/6 x^3/b^2]_0^b Fb 1/EJ + 1 (-1) 1 Fb^2/EJ$$

$$= (-1/2 b + 1/6 b) Fb 1/EJ + 1 (-1) 1 Fb^2/EJ = -4/3 Fb^2/EJ$$

$$L_{DE}^{xo} = \int_0^b (-1/2 + 2x/b - 3/2 x^2/b^2) Fb 1/EJ dx = [-1/2 x + x^2/b - 1/2 x^3/b^2]_0^b Fb 1/EJ$$

$$= (-1/2 b + b - 1/2 b) Fb 1/EJ = 0$$

$$L_{ED}^{xo} = \int_0^b (x/b - 3/2 x^2/b^2) Fb 1/EJ dx = [1/2 x^2/b - 1/2 x^3/b^2]_0^b Fb 1/EJ$$

$$= (1/2 b - 1/2 b) Fb 1/EJ = 0$$

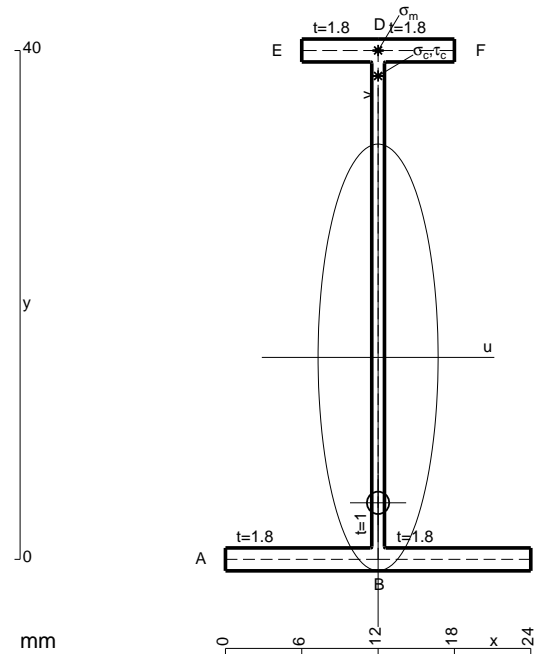

- A = 104.8 mm²
- J_u = 29473. mm⁴
- J_v = 2333. mm⁴
- J_t = 83.32 mm⁴
- y_o = -11.43 mm
- y_g = 15.88 mm
- N = -160. N
- T_y = -400. N
- M_x = -288000. Nmm
- x_m = 12. mm
- y_m = 40. mm
- v_m = 24.12 mm
- σ_m = N/A-Mv/J_u = 234.2 N/mm²
- y_c = 2. mm
- u_c = -12. mm
- v_c = -13.88 mm
- σ_c = N/A-Mv/J_u = 234.2 N/mm²
- τ_c = TS_t/J_u = 7.071 N/mm²
- τ_g = TS_t/J_u = 7.071 N/mm²
- t_c = 160. mm
- σ_o = √σ²+3τ² = 234.5 N/mm²

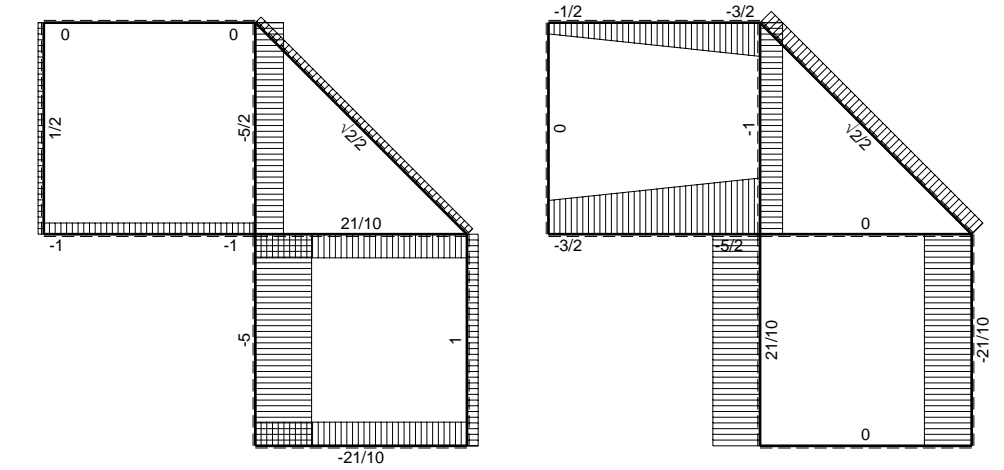
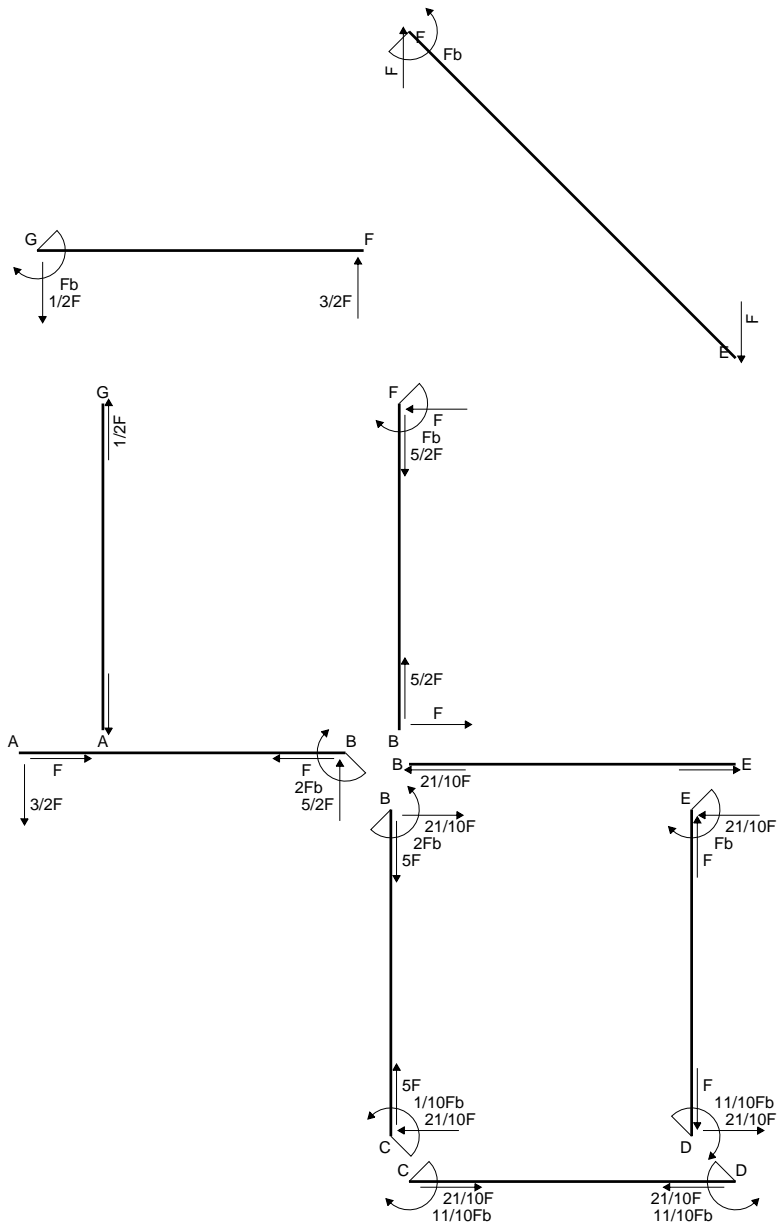

← ⊕ → F

↑ ⊕ ↓ F

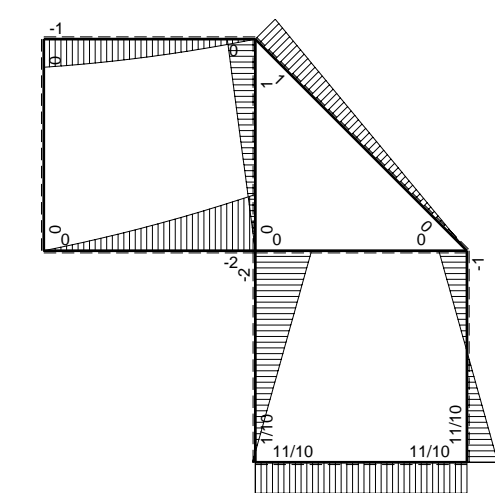

⊕ ⊖ F_b

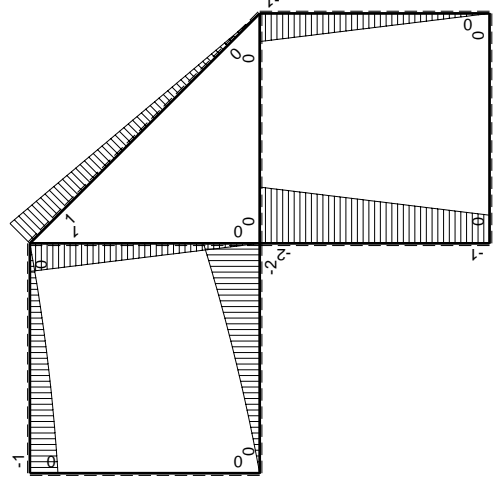
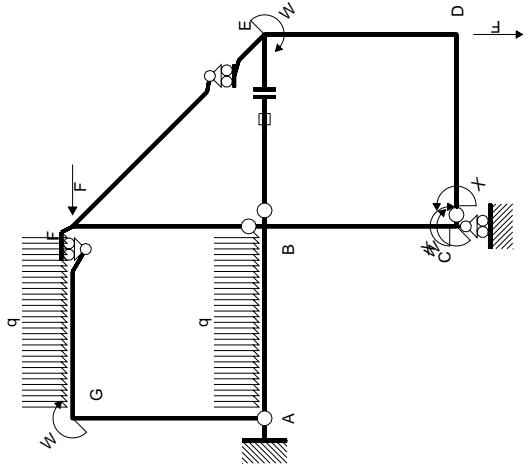

Schema di calcolo iperstatico

M_0 flessione da carichi assegnati

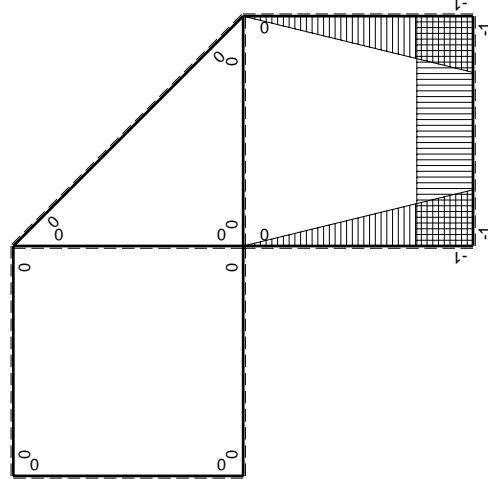

M_x flessione da iperstatica $X=1$

Quadro contribuiti PLV per iperstatica $X=W_{cd}$

\rightarrow	$M_x(x)$	$M_0(x)$	$M_x M_0$	$M_x M_x$	$\int M_x M_0 / EJ dx$	$\int X M_x M_x / EJ dx$
AB b	0	$-3/2Fx - 1/2qx^2$	0	0	0	0
BA b	0	$2Fb - 5/2Fx + 1/2qx^2$	0	0	0	0
BC b	$-x/b$	$-2Fb + Fx$	$2Fx - Fx^2/b$	x^2/b^2	$2/3Fb^2/EJ$	$1/3Xb/EJ$
CB b	$1-x/b$	$Fb + Fx$	$Fb - Fx^2/b$	$1 - 2x/b + x^2/b^2$		
CD b	-1	0	0	1	0	Xb/EJ
DC b	1	0	0	1	0	
DE b	$-1+x/b$	$-Fx$	$Fx - Fx^2/b$	$1 - 2x/b + x^2/b^2$	$1/6Fb^2/EJ$	$1/3Xb/EJ$
ED b	x/b	$Fb - Fx$	$Fx - Fx^2/b$	x^2/b^2		
EF $\sqrt{2}b$	0	$\sqrt{2}/2Fx$	0	0	0	0
FG b	0	$-3/2Fx + 1/2qx^2$	0	0	0	0
GF b	0	$Fb - 1/2Fx - 1/2qx^2$	0	0	0	0
GA b	0	0	0	0	0	0
AG b	0	0	0	0	0	0
FB b	0	$Fb - Fx$	0	0	0	0
BF b	0	$-Fx$	0	0	0	0
BE b	0	0	0	0	0	0
EB b	0	0	0	0	0	0
BE	elongazione asta $N_{1, BE} \epsilon_{BE} L_{BE}$				Fb^2/EJ	
	totali				$11/6Fb^2/EJ$	$5/3Xb/EJ$
	iperstatica $X=W_{cd}$					$-11/10Fb$

Sviluppi di calcolo iperstatica

$$L_{BC}^{xx} = \int_0^b (x^2/b^2) 1/EJ dx = [1/3 x^3/b^2]_0^b 1/EJ$$

$$= (1/3 b) 1/EJ = 1/3 b/EJ$$

$$L_{CB}^{xx} = \int_0^b (1 - 2x/b + x^2/b^2) 1/EJ dx = [x - x^2/b + 1/3 x^3/b^2]_0^b 1/EJ$$

$$= (b - b + 1/3 b) 1/EJ = 1/3 b/EJ$$

$$L_{CD}^{xx} = \int_0^b (1) 1/EJ dx = [x]_0^b 1/EJ$$

$$= (b) 1/EJ = b/EJ$$

$$L_{DC}^{xx} = \int_0^b (1) 1/EJ dx = [x]_0^b 1/EJ$$

$$= (b) 1/EJ = b/EJ$$

$$L_{DE}^{xx} = \int_0^b (1 - 2x/b + x^2/b^2) 1/EJ dx = [x - x^2/b + 1/3 x^3/b^2]_0^b 1/EJ$$

$$= (b - b + 1/3 b) 1/EJ = 1/3 b/EJ$$

$$L_{ED}^{xx} = \int_0^b (x^2/b^2) 1/EJ dx = [1/3 x^3/b^2]_0^b 1/EJ$$

$$= (1/3 b) 1/EJ = 1/3 b/EJ$$

$$L_{BC}^{x_0} = \int_0^b (2x/b - x^2/b^2) Fb 1/EJ dx = [x^2/b - 1/3 x^3/b^2]_0^b Fb 1/EJ$$

$$= (b - 1/3 b) Fb 1/EJ = 2/3 Fb^2/EJ$$

$$L_{CB}^{x_0} = \int_0^b (1 - x^2/b^2) Fb 1/EJ dx = [x - 1/3 x^3/b^2]_0^b Fb 1/EJ$$

$$= (b - 1/3 b) Fb 1/EJ = 2/3 Fb^2/EJ$$

$$L_{DE}^{x_0} = \int_0^b (x/b - x^2/b^2) Fb 1/EJ dx = [1/2 x^2/b - 1/3 x^3/b^2]_0^b Fb 1/EJ$$

$$= (1/2 b - 1/3 b) Fb 1/EJ = 1/6 Fb^2/EJ$$

$$L_{ED}^{x_0} = \int_0^b (x/b - x^2/b^2) Fb 1/EJ dx = [1/2 x^2/b - 1/3 x^3/b^2]_0^b Fb 1/EJ$$

$$= (1/2 b - 1/3 b) Fb 1/EJ = 1/6 Fb^2/EJ$$

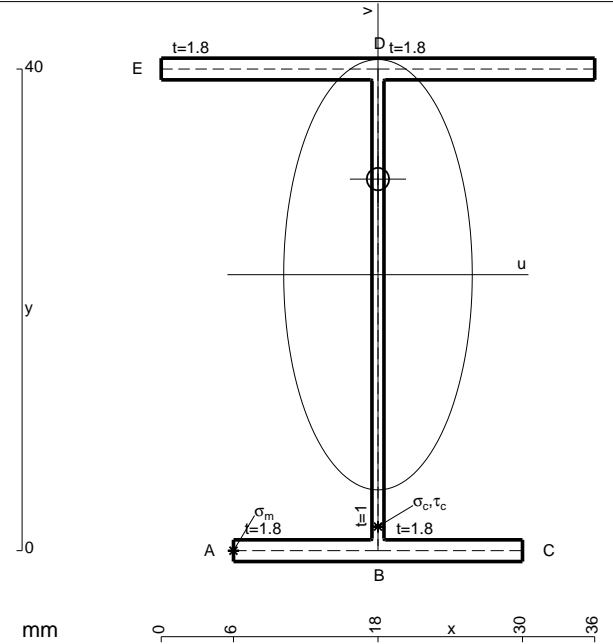

- A = 148. mm²
- J_u = 47272. mm⁴
- J_v = 9072. mm⁴
- J_i = 130. mm⁴
- y_o = 7.938 mm
- y_g = 22.92 mm
- N = -530. N
- T_y = -1325. N
- M_x = -402800. Nmm
- x_m = 6. mm
- u_m = -12. mm
- v_m = -22.92 mm
- σ_m = N/A-Mv/J_u = -198.9 N/mm²
- x_c = 18. mm
- v_c = -22.92 mm
- σ_c = N/A-Mv/J_u = -198.9 N/mm²
- τ_c = TS¹/tJ_u = 27.75 N/mm²
- τ_g = TS¹/tJ_u = 27.75 N/mm²
- t_c = 530. mm
- σ_o = √σ²+3τ² = 204.6 N/mm²

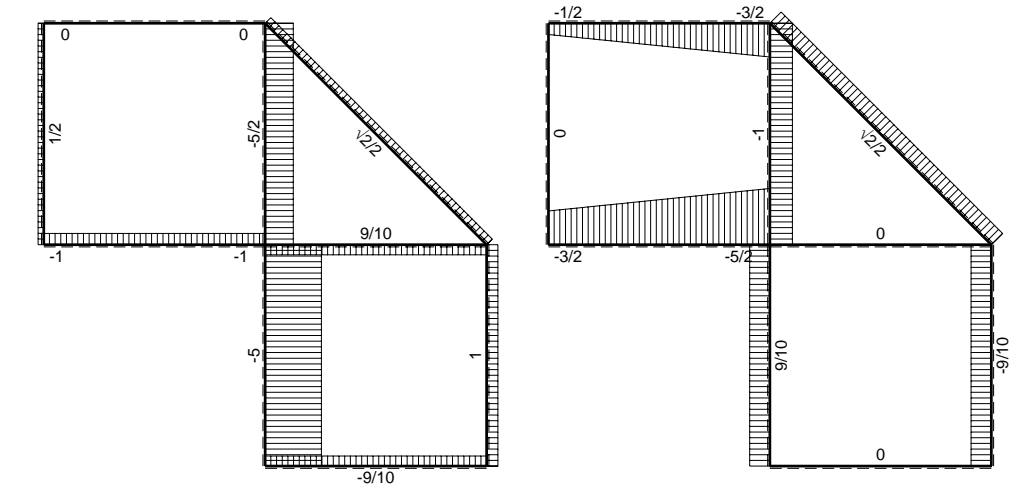
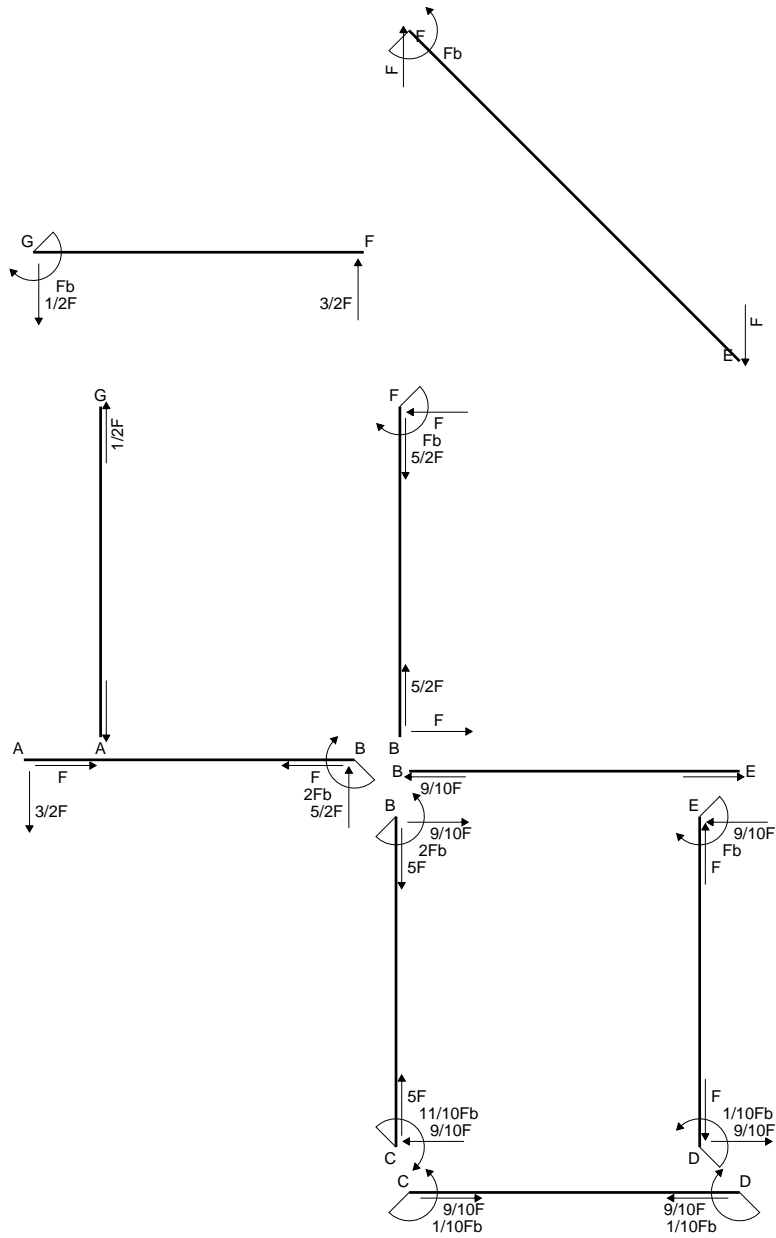

← ⊕ → F

↑ ⊕ ↓ F

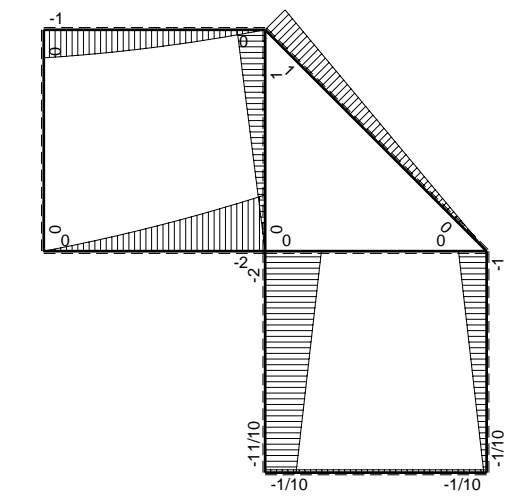

⊕ ⊖ F_b

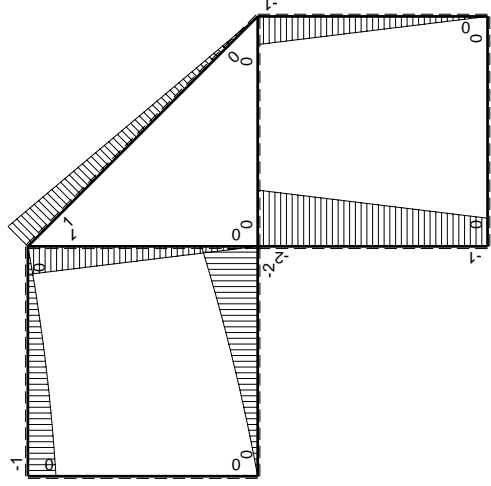
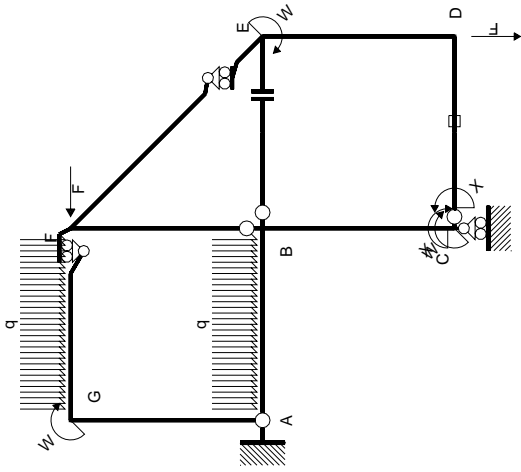

Schema di calcolo iperstatico

M_0 flessione da carichi assegnati

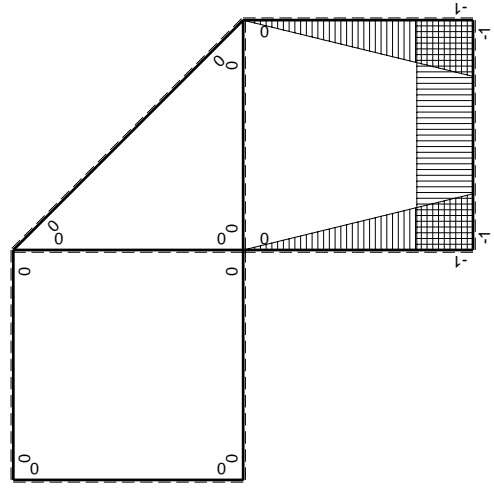

M_x flessione da iperstatica $X=1$

Quadro contribuiti PLV per iperstatica $X=W_{cd}$

\rightarrow	$M_x(x)$	$M_0(x)$	$M_x M_0$	$M_x M_x$	$\int M_x M_0 / EJ dx$	$\int M_x M_x / EJ dx$
AB b	0	$-3/2Fx - 1/2qx^2$	0	0	0	0
BA b	0	$2Fb - 5/2Fx + 1/2qx^2$	0	0	0	0
BC b	$-x/b$	$-2Fb + Fx$	$2Fx - Fx^2/b$	x^2/b^2	$2/3Fb^2/EJ$	$1/3Xb/EJ$
CB b	$1-x/b$	$Fb + Fx$	$Fb - Fx^2/b$	$1 - 2x/b + x^2/b^2$		
CD b	-1	0	0	1	0	Xb/EJ
DC b	1	0	0	1	0	
DE b	$-1+x/b$	$-Fx$	$Fx - Fx^2/b$	$1 - 2x/b + x^2/b^2$	$1/6Fb^2/EJ$	$1/3Xb/EJ$
ED b	x/b	$Fb - Fx$	$Fx - Fx^2/b$	x^2/b^2		
EF $\sqrt{2}b$	0	$\sqrt{2}/2Fx$	0	0	0	0
FG b	0	$-3/2Fx + 1/2qx^2$	0	0	0	0
GF b	0	$Fb - 1/2Fx - 1/2qx^2$	0	0	0	0
GA b	0	0	0	0	0	0
AG b	0	0	0	0	0	0
FB b	0	$Fb - Fx$	0	0	0	0
BF b	0	$-Fx$	0	0	0	0
BE b	0	0	0	0	0	0
EB b	0	0	0	0	0	0
CD	elongazione asta $N_{1,cd} \epsilon_{cd} L_{cd}$				$-Fb^2/EJ$	
	totali				$-1/6Fb^2/EJ$	$5/3Xb/EJ$
	iperstatica $X=W_{cd}$				$1/10Fb$	

Sviluppi di calcolo iperstatica

$$L_{BC}^{xx} = \int_0^b (x^2/b^2) 1/EJ dx = [1/3 x^3/b^2]_0^b 1/EJ$$

$$= (1/3 b) 1/EJ = 1/3 b/EJ$$

$$L_{CB}^{xx} = \int_0^b (1 - 2x/b + x^2/b^2) 1/EJ dx = [x - x^2/b + 1/3 x^3/b^2]_0^b 1/EJ$$

$$= (b - b + 1/3 b) 1/EJ = 1/3 b/EJ$$

$$L_{CD}^{xx} = \int_0^b (1) 1/EJ dx = [x]_0^b 1/EJ$$

$$= (b) 1/EJ = b/EJ$$

$$L_{DC}^{xx} = \int_0^b (1) 1/EJ dx = [x]_0^b 1/EJ$$

$$= (b) 1/EJ = b/EJ$$

$$L_{DE}^{xx} = \int_0^b (1 - 2x/b + x^2/b^2) 1/EJ dx = [x - x^2/b + 1/3 x^3/b^2]_0^b 1/EJ$$

$$= (b - b + 1/3 b) 1/EJ = 1/3 b/EJ$$

$$L_{ED}^{xx} = \int_0^b (x^2/b^2) 1/EJ dx = [1/3 x^3/b^2]_0^b 1/EJ$$

$$= (1/3 b) 1/EJ = 1/3 b/EJ$$

$$L_{BC}^{x_0} = \int_0^b (2x/b - x^2/b^2) Fb 1/EJ dx = [x^2/b - 1/3 x^3/b^2]_0^b Fb 1/EJ$$

$$= (b - 1/3 b) Fb 1/EJ = 2/3 Fb^2/EJ$$

$$L_{CB}^{x_0} = \int_0^b (1 - x^2/b^2) Fb 1/EJ dx = [x - 1/3 x^3/b^2]_0^b Fb 1/EJ$$

$$= (b - 1/3 b) Fb 1/EJ = 2/3 Fb^2/EJ$$

$$L_{DE}^{x_0} = \int_0^b (x/b - x^2/b^2) Fb 1/EJ dx = [1/2 x^2/b - 1/3 x^3/b^2]_0^b Fb 1/EJ$$

$$= (1/2 b - 1/3 b) Fb 1/EJ = 1/6 Fb^2/EJ$$

$$L_{ED}^{x_0} = \int_0^b (x/b - x^2/b^2) Fb 1/EJ dx = [1/2 x^2/b - 1/3 x^3/b^2]_0^b Fb 1/EJ$$

$$= (1/2 b - 1/3 b) Fb 1/EJ = 1/6 Fb^2/EJ$$

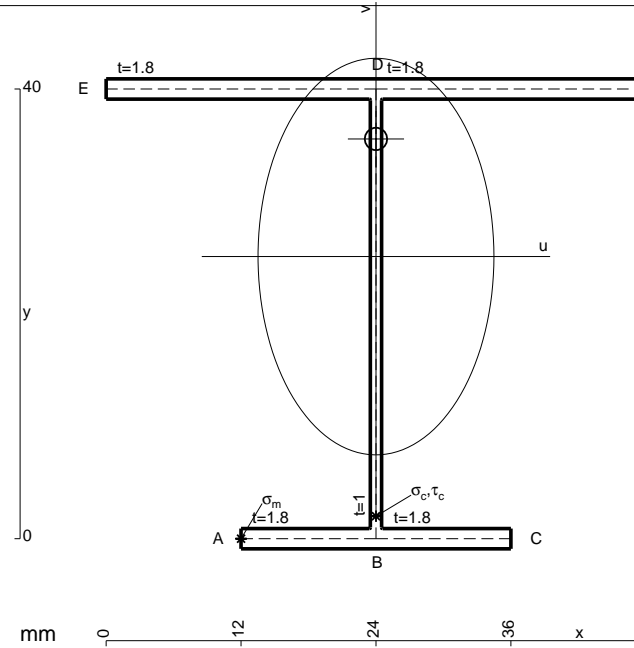

- A = 169.6 mm²
- J_u = 52772. mm⁴
- J_v = 18662. mm⁴
- J_t = 153.3 mm⁴
- y_o = 10.46 mm
- y_g = 25.09 mm
- N = -530. N
- T_y = -1325. N
- M_x = -434600. Nmm
- x_m = 12. mm
- u_m = -12. mm
- v_m = -25.09 mm
- σ_m = N/A-Mv/J_u = -209.8 N/mm²
- x_c = 24. mm
- v_c = -25.09 mm
- σ_c = N/A-Mv/J_u = -209.8 N/mm²
- τ_c = TS¹/tJ_u = 27.22 N/mm²
- τ_g = TS¹/tJ_u = 27.22 N/mm²
- t_c = 530. mm
- σ_o = √σ²+3τ² = 215. N/mm²

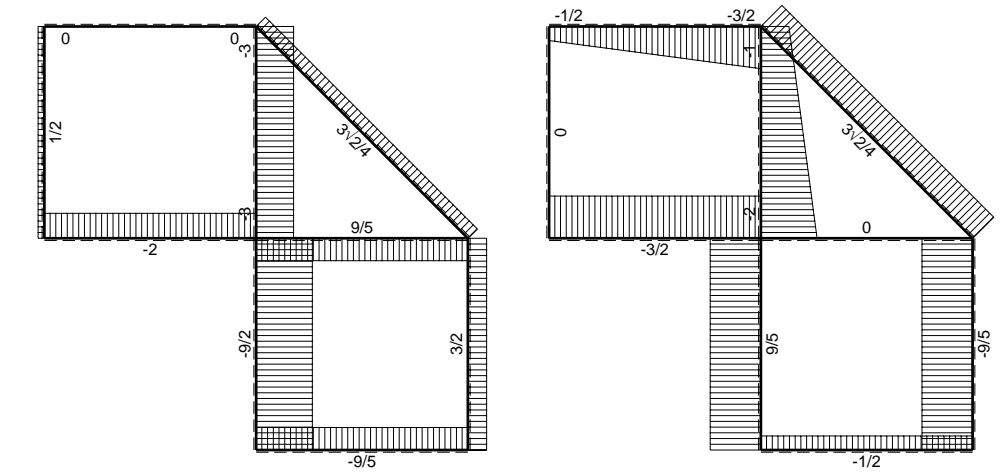
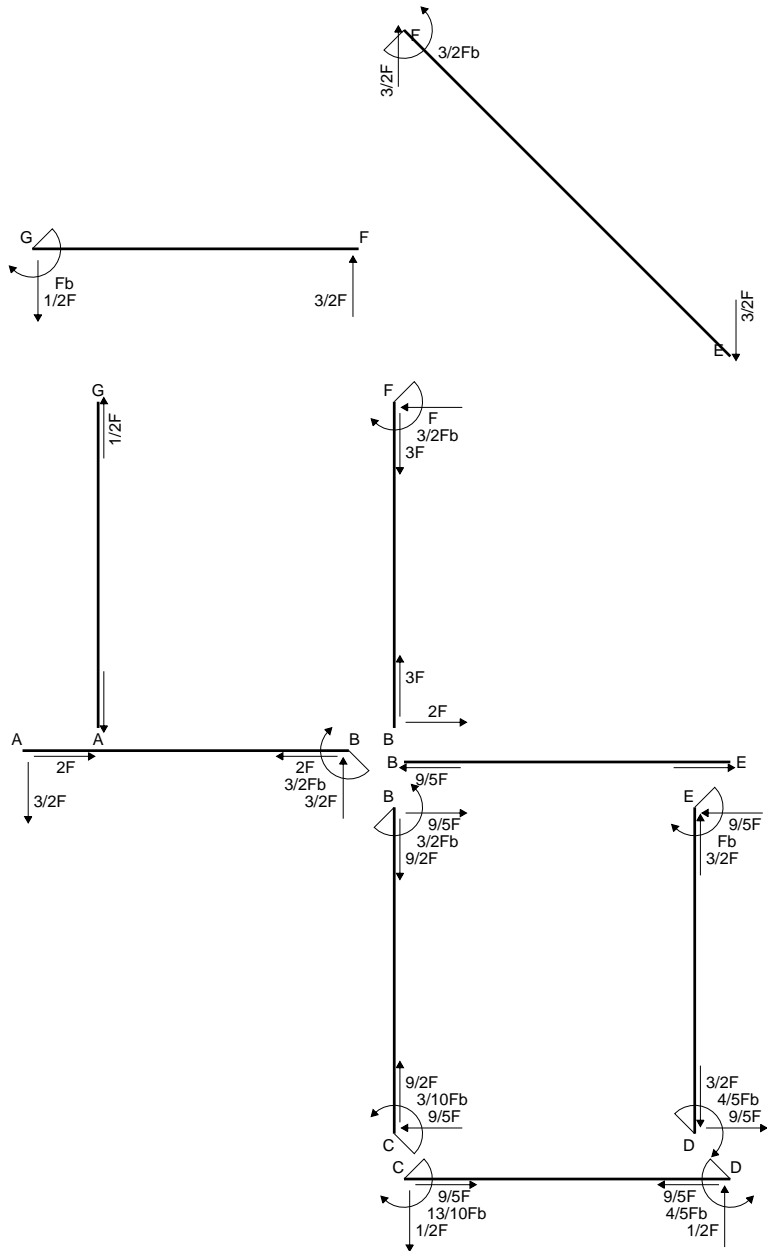

← ⊕ → F

↑ ⊕ ↓ F

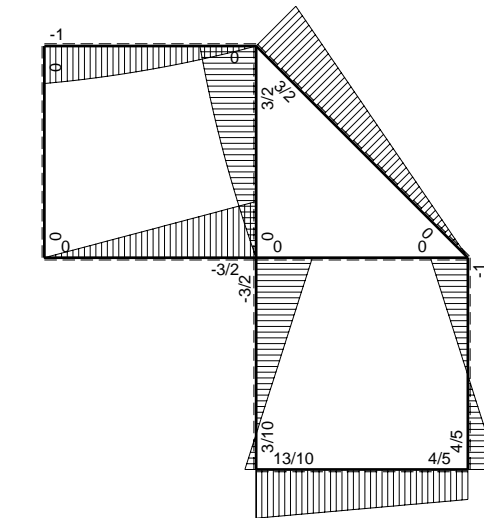

⊕ ⊖ Fb

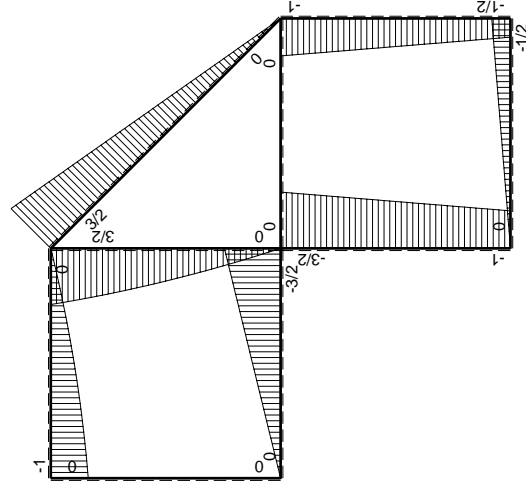
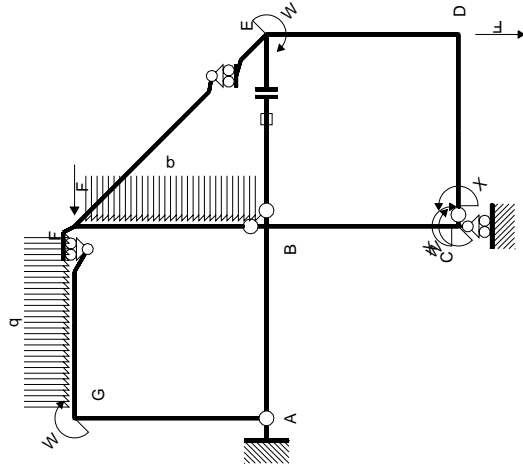

Schema di calcolo iperstatico

M_0 flessione da carichi assegnati

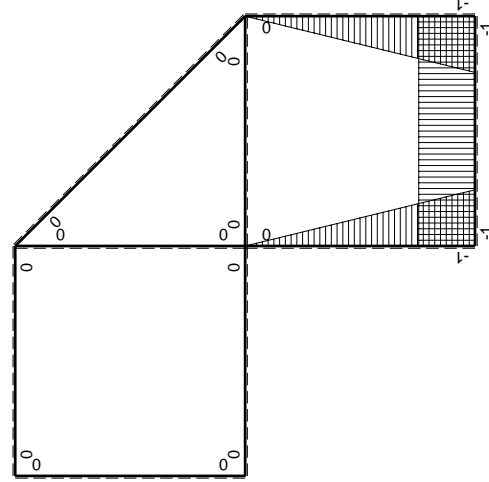

M_x flessione da iperstatica $X=1$

Quadro contribuiti PLV per iperstatica $X=W_{cd}$

\rightarrow	$M_x(x)$	$M_0(x)$	$M_x M_0$	$M_x M_x$	$\int M_x M_0 / E J dx$	$\int M_x M_x / E J dx$
AB b	0	-3/2Fx	0	0	0	0
BA b	0	3/2Fb-3/2Fx	0	0	0	0
BC b	-x/b	-3/2Fb+1/2Fx	3/2Fx-1/2Fx ² /b	x ² /b ²	7/12Fb ² /EJ	1/3Xb/EJ
CB b	1-x/b	Fb+1/2Fx	Fb-1/2Fx-1/2Fx ² /b	1-2x/b+x ² /b ²	1/4Fb ² /EJ	Xb/EJ
CD b	-1	-1/2Fx	1/2Fx	1	1/4Fb ² /EJ	Xb/EJ
DC b	1	1/2Fb-1/2Fx	1/2Fb-1/2Fx	1	1/3Fb ² /EJ	1/3Xb/EJ
DE b	-1+x/b	-1/2Fb-1/2Fx	1/2Fb-1/2Fx ² /b	1-2x/b+x ² /b ²	1/3Fb ² /EJ	1/3Xb/EJ
ED b	x/b	Fb-1/2Fx	Fx-1/2Fx ² /b	x ² /b ²	0	0
EF $\sqrt{2}b$	0	3\sqrt{2}/4Fx	0	0	0	0
FG b	0	-3/2Fx+1/2qx ²	0	0	0	0
GF b	0	Fb-1/2Fx-1/2qx ²	0	0	0	0
GA b	0	0	0	0	0	0
AG b	0	0	0	0	0	0
FB b	0	3/2Fb-Fx-1/2qx ²	0	0	0	0
BF b	0	-2Fx+1/2qx ²	0	0	0	0
BE b	0	0	0	0	0	0
EB b	0	0	0	0	0	0
BE	elongazione asta $N_{1, BE}^{\epsilon_{BE} - BE}$				Fb ² /EJ	
	totali				13/6Fb ² /EJ	5/3Xb/EJ
	iperstatica $X=W_{cd}$				-13/10Fb	

Sviluppi di calcolo iperstatica

$$L_{BC}^{xx} = \int_0^b (x^2/b^2) 1/EJ dx = [1/3 x^3/b^2]_0^b 1/EJ$$

$$= (1/3 b) 1/EJ = 1/3 b/EJ$$

$$L_{CB}^{xx} = \int_0^b (1 - 2x/b + x^2/b^2) 1/EJ dx = [x - x^2/b + 1/3 x^3/b^2]_0^b 1/EJ$$

$$= (b - b + 1/3 b) 1/EJ = 1/3 b/EJ$$

$$L_{CD}^{xx} = \int_0^b (1) 1/EJ dx = [x]_0^b 1/EJ$$

$$= (b) 1/EJ = b/EJ$$

$$L_{DC}^{xx} = \int_0^b (1) 1/EJ dx = [x]_0^b 1/EJ$$

$$= (b) 1/EJ = b/EJ$$

$$L_{DE}^{xx} = \int_0^b (1 - 2x/b + x^2/b^2) 1/EJ dx = [x - x^2/b + 1/3 x^3/b^2]_0^b 1/EJ$$

$$= (b - b + 1/3 b) 1/EJ = 1/3 b/EJ$$

$$L_{ED}^{xx} = \int_0^b (x^2/b^2) 1/EJ dx = [1/3 x^3/b^2]_0^b 1/EJ$$

$$= (1/3 b) 1/EJ = 1/3 b/EJ$$

$$L_{BC}^{x_0} = \int_0^b (3/2 x/b - 1/2 x^2/b^2) Fb 1/EJ dx = [3/4 x^2/b - 1/6 x^3/b^2]_0^b Fb 1/EJ$$

$$= (3/4 b - 1/6 b) Fb 1/EJ = 7/12 Fb^2/EJ$$

$$L_{CB}^{x_0} = \int_0^b (1 - 1/2 x/b - 1/2 x^2/b^2) Fb 1/EJ dx = [x - 1/4 x^2/b - 1/6 x^3/b^2]_0^b Fb 1/EJ$$

$$= (b - 1/4 b - 1/6 b) Fb 1/EJ = 7/12 Fb^2/EJ$$

$$L_{CD}^{x_0} = \int_0^b (1/2 x/b) Fb 1/EJ dx = [1/4 x^2/b]_0^b Fb 1/EJ$$

$$= (1/4 b) Fb 1/EJ = 1/4 Fb^2/EJ$$

$$L_{DC}^{x_0} = \int_0^b (1/2 - 1/2 x/b) Fb 1/EJ dx = [1/2 x - 1/4 x^2/b]_0^b Fb 1/EJ$$

$$= (1/2 b - 1/4 b) Fb 1/EJ = 1/4 Fb^2/EJ$$

$$L_{DE}^{x_0} = \int_0^b (1/2 - 1/2 x^2/b^2) Fb 1/EJ dx = [1/2 x - 1/6 x^3/b^2]_0^b Fb 1/EJ$$

$$= (1/2 b - 1/6 b) Fb 1/EJ = 1/3 Fb^2/EJ$$

$$L_{ED}^{x_0} = \int_0^b (x/b - 1/2 x^2/b^2) Fb 1/EJ dx = [1/2 x^2/b - 1/6 x^3/b^2]_0^b Fb 1/EJ$$

$$= (1/2 b - 1/6 b) Fb 1/EJ = 1/3 Fb^2/EJ$$

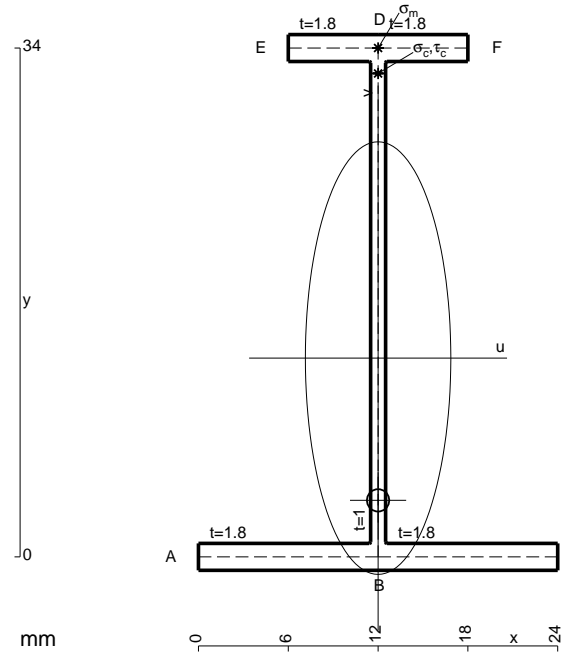

$A = 98.8 \text{ mm}^2$
 $J_u = 20638. \text{ mm}^4$
 $J_v = 2333. \text{ mm}^4$
 $J_t = 81.32 \text{ mm}^4$
 $y_o = -9.506 \text{ mm}$
 $y_g = 13.28 \text{ mm}$
 $N = -780. \text{ N}$
 $T_y = -585. \text{ N}$
 $M_x = -222300. \text{ Nmm}$
 $x_m = 12. \text{ mm}$
 $y_m = 34. \text{ mm}$
 $v_m = 20.72 \text{ mm}$
 $\sigma_m = N/A - Mv/J_u = 215.3 \text{ N/mm}^2$
 $y_c = 2. \text{ mm}$
 $u_c = -12. \text{ mm}$
 $v_c = -11.28 \text{ mm}$
 $\sigma_c = N/A - Mv/J_u = 215.3 \text{ N/mm}^2$
 $\tau_c = TS/tJ_u = 12.68 \text{ N/mm}^2$
 $\tau_g = TS/tJ_u = 12.68 \text{ N/mm}^2$
 $t_c = 390. \text{ mm}$
 $\sigma_o = \sqrt{\sigma^2 + 3\tau^2} = 216.4 \text{ N/mm}^2$

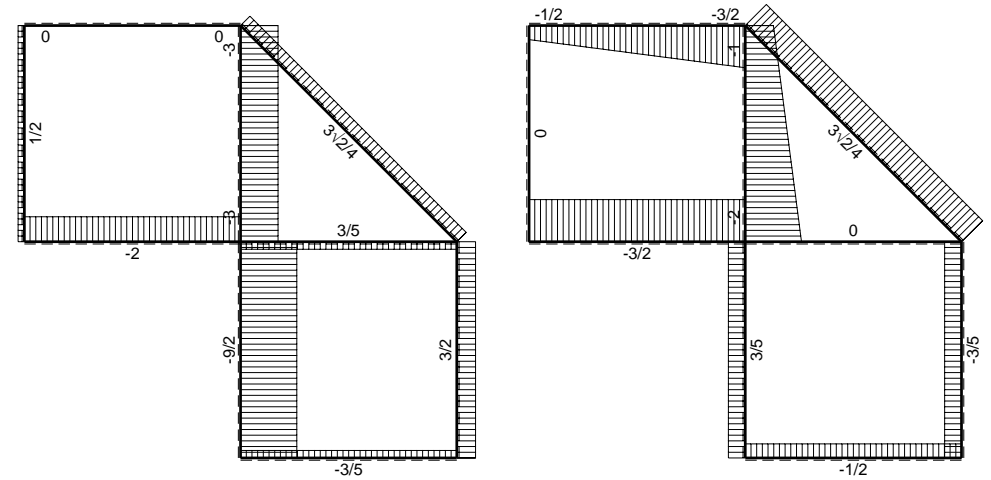
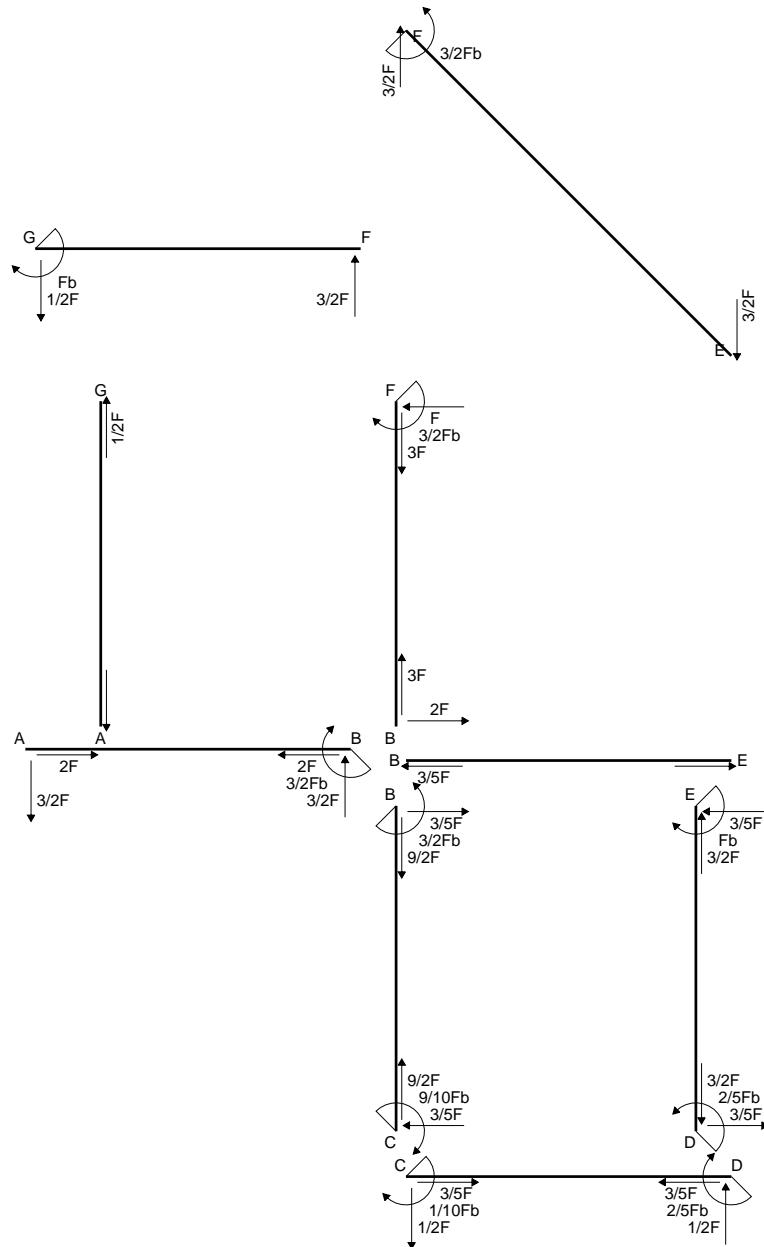

← ⊕ → F

↑ ⊕ ↓ F

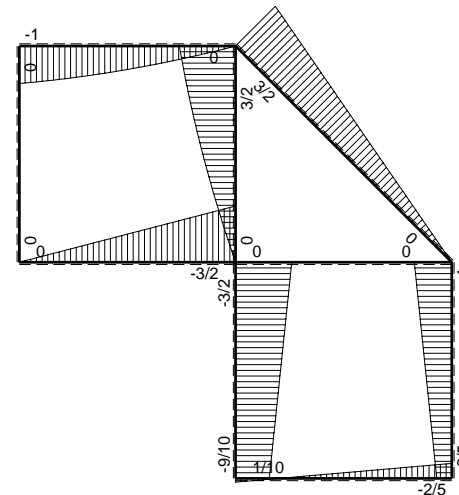

⊕ ⊖ Fb

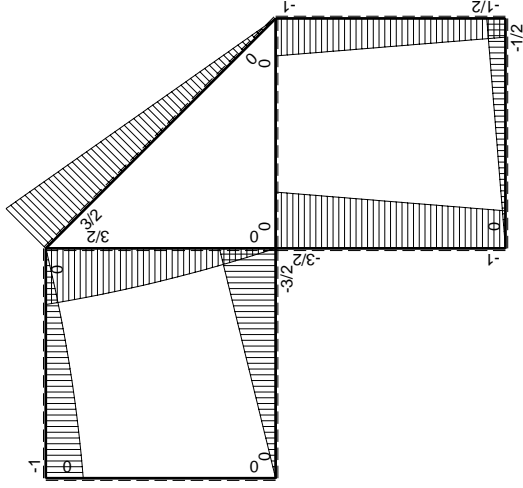
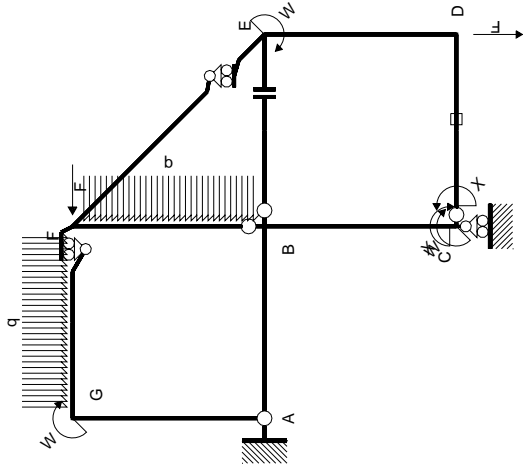

Schema di calcolo iperstatico

M_0 flessione da carichi assegnati

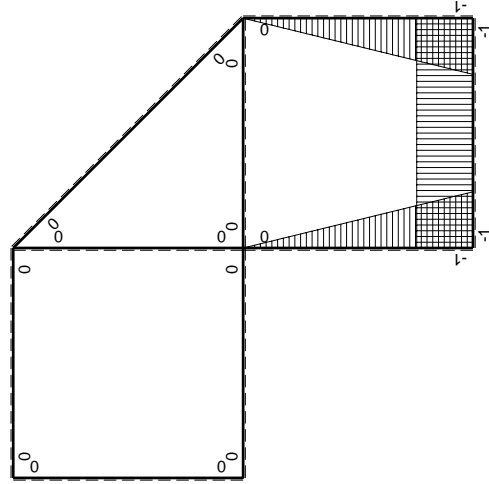

M_x flessione da iperstatica X=1

Quadro contribuiti PLV per iperstatica X=W_{cd}

→	$M_x(x)$	$M_0(x)$	$M_x M_0$	$M_x M_x$	$\int M_x M_0 / E J dx$	$\int M_x M_x / E J dx$
AB b	0	-3/2Fx	0	0	0	0
BA b	0	3/2Fb-3/2Fx	0	0	0	0
BC b	-x/b	-3/2Fb+1/2Fx	3/2Fx-1/2Fx ² /b	x ² /b ²	7/12Fb ² /EJ	1/3Xb/EJ
CB b	1-x/b	Fb+1/2Fx	Fb-1/2Fx-1/2Fx ² /b	1-2x/b+x ² /b ²	1/4Fb ² /EJ	Xb/EJ
CD b	-1	-1/2Fx	1/2Fx	1	1/4Fb ² /EJ	Xb/EJ
DC b	1	1/2Fb-1/2Fx	1/2Fb-1/2Fx	1	1/4Fb ² /EJ	Xb/EJ
DE b	-1+x/b	-1/2Fb-1/2Fx	1/2Fb-1/2Fx ² /b	1-2x/b+x ² /b ²	1/3Fb ² /EJ	1/3Xb/EJ
ED b	x/b	Fb-1/2Fx	Fx-1/2Fx ² /b	x ² /b ²	1/3Fb ² /EJ	1/3Xb/EJ
EF √2b	0	3√2/4Fx	0	0	0	0
FG b	0	-3/2Fx+1/2qx ²	0	0	0	0
GF b	0	Fb-1/2Fx-1/2qx ²	0	0	0	0
GA b	0	0	0	0	0	0
AG b	0	0	0	0	0	0
FB b	0	3/2Fb-Fx-1/2qx ²	0	0	0	0
BF b	0	-2Fx+1/2qx ²	0	0	0	0
BE b	0	0	0	0	0	0
EB b	0	0	0	0	0	0
CD	elongazione asta $N_{1,cd} \epsilon_{cd} L_{cd}$				-Fb ² /EJ	
	totali				1/6Fb ² /EJ	5/3Xb/EJ
	iperstatica X=W _{cd}				-1/10Fb	

Sviluppi di calcolo iperstatica

$$L_{BC}^{xx} = \int_0^b (x^2/b^2) 1/EJ dx = [1/3 x^3/b^2]_0^b 1/EJ$$

$$= (1/3 b) 1/EJ = 1/3 b/EJ$$

$$L_{CB}^{xx} = \int_0^b (1 - 2x/b + x^2/b^2) 1/EJ dx = [x - x^2/b + 1/3 x^3/b^2]_0^b 1/EJ$$

$$= (b - b + 1/3 b) 1/EJ = 1/3 b/EJ$$

$$L_{CD}^{xx} = \int_0^b (1) 1/EJ dx = [x]_0^b 1/EJ$$

$$= (b) 1/EJ = b/EJ$$

$$L_{DC}^{xx} = \int_0^b (1) 1/EJ dx = [x]_0^b 1/EJ$$

$$= (b) 1/EJ = b/EJ$$

$$L_{DE}^{xx} = \int_0^b (1 - 2x/b + x^2/b^2) 1/EJ dx = [x - x^2/b + 1/3 x^3/b^2]_0^b 1/EJ$$

$$= (b - b + 1/3 b) 1/EJ = 1/3 b/EJ$$

$$L_{ED}^{xx} = \int_0^b (x^2/b^2) 1/EJ dx = [1/3 x^3/b^2]_0^b 1/EJ$$

$$= (1/3 b) 1/EJ = 1/3 b/EJ$$

$$L_{BC}^{xo} = \int_0^b (3/2 x/b - 1/2 x^2/b^2) Fb 1/EJ dx = [3/4 x^2/b - 1/6 x^3/b^2]_0^b Fb 1/EJ$$

$$= (3/4 b - 1/6 b) Fb 1/EJ = 7/12 Fb^2/EJ$$

$$L_{CB}^{xo} = \int_0^b (1 - 1/2 x/b - 1/2 x^2/b^2) Fb 1/EJ dx = [x - 1/4 x^2/b - 1/6 x^3/b^2]_0^b Fb 1/EJ$$

$$= (b - 1/4 b - 1/6 b) Fb 1/EJ = 7/12 Fb^2/EJ$$

$$L_{CD}^{xo} = \int_0^b (1/2 x/b) Fb 1/EJ dx + 1 (-1) 1 Fb^2/EJ = [1/4 x^2/b]_0^b Fb 1/EJ + 1 (-1) 1 Fb^2/EJ$$

$$= (1/4 b) Fb 1/EJ + 1 (-1) 1 Fb^2/EJ = -3/4 Fb^2/EJ$$

$$L_{DC}^{xo} = \int_0^b (1/2 - 1/2 x/b) Fb 1/EJ dx + 1 (-1) 1 Fb^2/EJ = [1/2 x - 1/4 x^2/b]_0^b Fb 1/EJ + 1 (-1) 1 Fb^2/EJ$$

$$= (1/2 b - 1/4 b) Fb 1/EJ + 1 (-1) 1 Fb^2/EJ = -3/4 Fb^2/EJ$$

$$L_{DE}^{xo} = \int_0^b (1/2 - 1/2 x^2/b^2) Fb 1/EJ dx = [1/2 x - 1/6 x^3/b^2]_0^b Fb 1/EJ$$

$$= (1/2 b - 1/6 b) Fb 1/EJ = 1/3 Fb^2/EJ$$

$$L_{ED}^{xo} = \int_0^b (x/b - 1/2 x^2/b^2) Fb 1/EJ dx = [1/2 x^2/b - 1/6 x^3/b^2]_0^b Fb 1/EJ$$

$$= (1/2 b - 1/6 b) Fb 1/EJ = 1/3 Fb^2/EJ$$

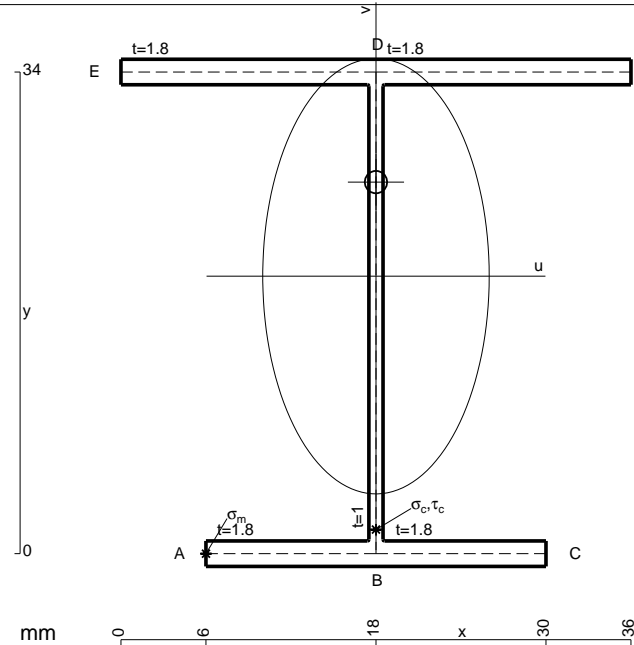

- A = 142. mm²
- J_u = 33538. mm⁴
- J_v = 9072. mm⁴
- J_t = 128. mm⁴
- y_o = 6.643 mm
- y_g = 19.59 mm
- N = -1220. N
- T_y = -915. N
- M_x = -375150. Nmm
- x_m = 6. mm
- u_m = -12. mm
- v_m = -19.59 mm
- σ_m = N/A-Mv/J_u = -227.7 N/mm²
- x_c = 18. mm
- v_c = -19.59 mm
- σ_c = N/A-Mv/J_u = -227.7 N/mm²
- τ_c = TS¹/tJ_u = 23.08 N/mm²
- τ_g = TS¹/tJ_u = 23.08 N/mm²
- t_c = 610. mm
- σ_o = √σ²+3τ² = 231.2 N/mm²

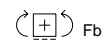
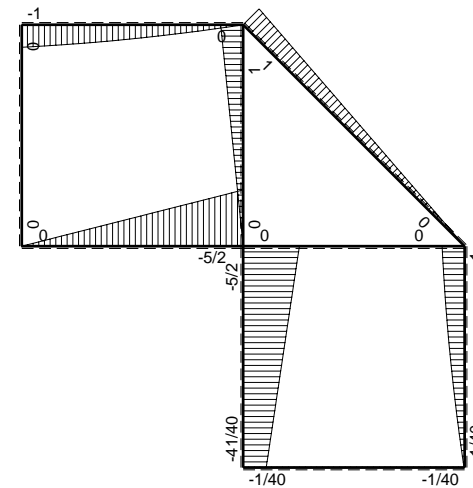
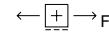
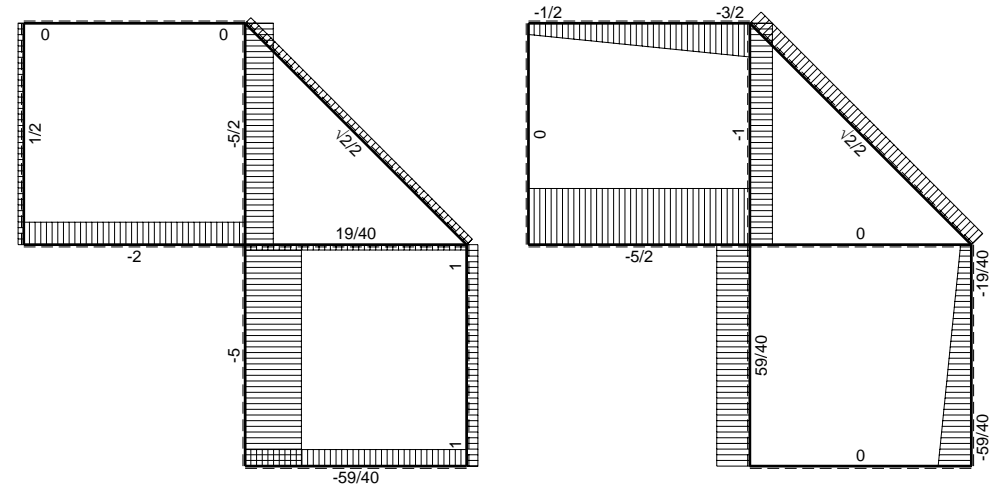
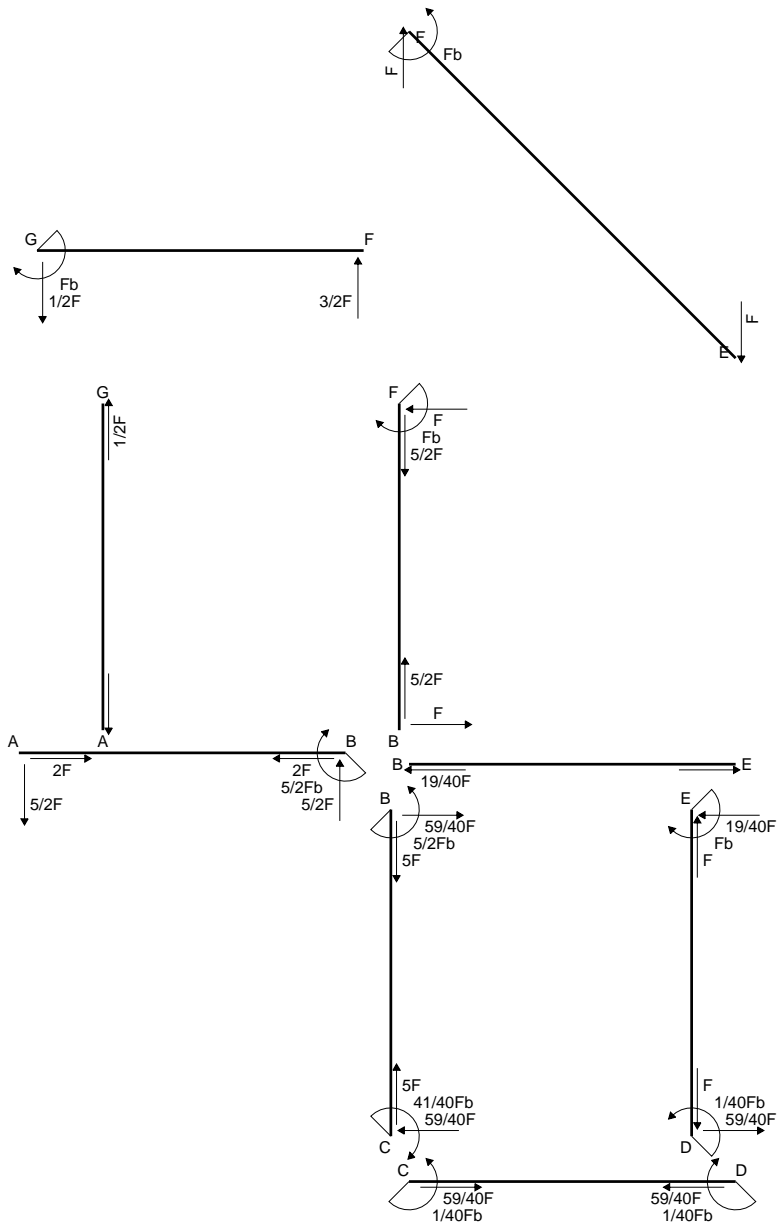

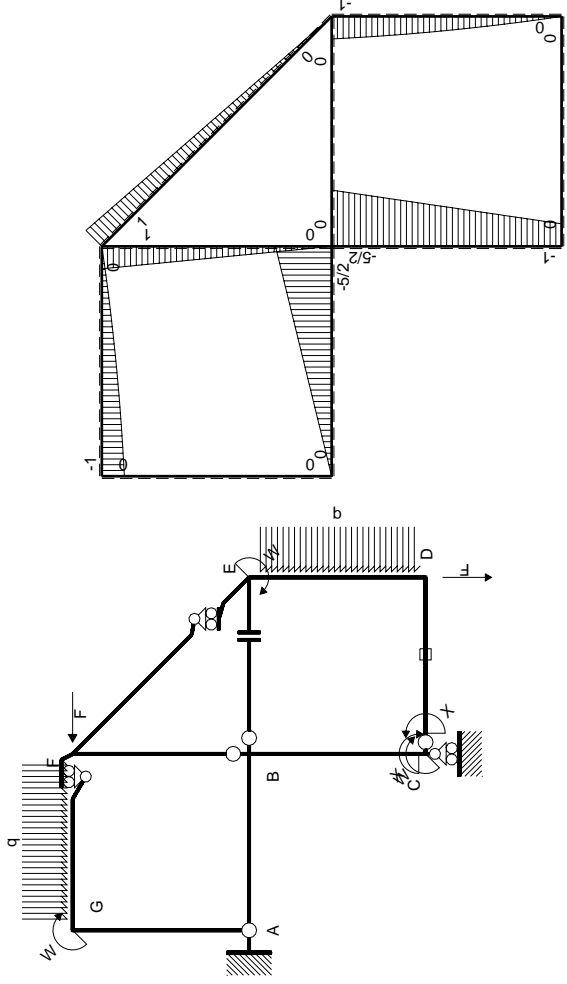

Schema di calcolo iperstatico

M_0 flessione da carichi assegnati

M_x flessione da iperstatica $X=1$

Quadro contributi PLV per iperstatica $X=W_{cd}$

\rightarrow	$M_x(x)$	$M_0(x)$	$M_x M_0$	$M_x M_x$	$\int M_x M_0 / EJ dx$	$\int M_x M_x / EJ dx$
AB b	0	-5/2Fx	0	0	0	0
BA b	0	5/2Fb-5/2Fx	0	0	0	0
BC b	-x/b	-5/2Fb+3/2Fx	5/2Fx-3/2Fx ² /b	x ² /b ²	3/4Fb ² /EJ	1/3Xb/EJ
CB b	1-x/b	Fb+3/2Fx	Fb+1/2Fx-3/2Fx ² /b	1-2x/b+x ² /b ²	0	Xb/EJ
CD b	-1	0	0	1	0	0
DC b	1	0	0	1	0	0
DE b	-1+x/b	-3/2Fx+1/2qx ²	3/2Fx-2Fx ² /b+1/2qx ³ /b	1-2x/b+x ² /b ²	5/24Fb ² /EJ	1/3Xb/EJ
ED b	x/b	Fb-1/2Fx-1/2qx ²	Fx-1/2Fx ² /b-1/2qx ³ /b	x ² /b ²	0	0
EF $\sqrt{2}b$	0	$\sqrt{2}/2Fx$	0	0	0	0
FG b	0	-3/2Fx+1/2qx ²	0	0	0	0
GF b	0	Fb-1/2Fx-1/2qx ²	0	0	0	0
GA b	0	0	0	0	0	0
AG b	0	0	0	0	0	0
FB b	0	Fb-Fx	0	0	0	0
BF b	0	-Fx	0	0	0	0
BE b	0	0	0	0	0	0
EB b	0	0	0	0	0	0
CD	elongazione asta $N_{1,cd} \epsilon_{cd} L_{cd}$				-Fb ² /EJ	
	totali				-1/24Fb ² /EJ	5/3Xb/EJ
	iperstatica $X=W_{cd}$				1/40Fb	

Sviluppi di calcolo iperstatica

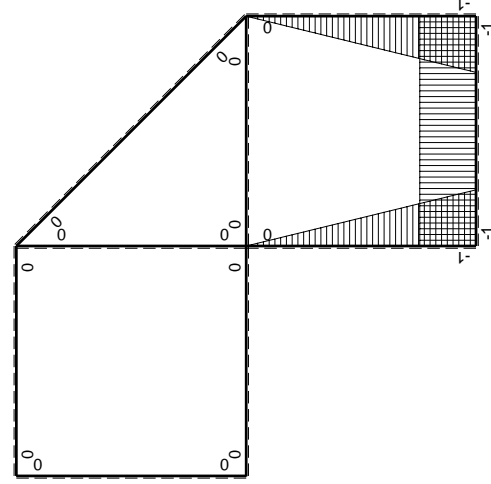

$$L_{BC}^{xx} = \int_0^b (x^2/b^2) 1/EJ dx = [1/3 x^3/b^2]_0^b 1/EJ$$

$$= (1/3 b) 1/EJ = 1/3 b/EJ$$

$$L_{CB}^{xx} = \int_0^b (1 - 2x/b + x^2/b^2) 1/EJ dx = [x - x^2/b + 1/3 x^3/b^2]_0^b 1/EJ$$

$$= (b - b + 1/3 b) 1/EJ = 1/3 b/EJ$$

$$L_{CD}^{xx} = \int_0^b (1) 1/EJ dx = [x]_0^b 1/EJ$$

$$= (b) 1/EJ = b/EJ$$

$$L_{DC}^{xx} = \int_0^b (1) 1/EJ dx = [x]_0^b 1/EJ$$

$$= (b) 1/EJ = b/EJ$$

$$L_{DE}^{xx} = \int_0^b (1 - 2x/b + x^2/b^2) 1/EJ dx = [x - x^2/b + 1/3 x^3/b^2]_0^b 1/EJ$$

$$= (b - b + 1/3 b) 1/EJ = 1/3 b/EJ$$

$$L_{ED}^{xx} = \int_0^b (x^2/b^2) 1/EJ dx = [1/3 x^3/b^2]_0^b 1/EJ$$

$$= (1/3 b) 1/EJ = 1/3 b/EJ$$

$$L_{BC}^{x_0} = \int_0^b (5/2 x/b - 3/2 x^2/b^2) Fb 1/EJ dx = [5/4 x^2/b - 1/2 x^3/b^2]_0^b Fb 1/EJ$$

$$= (5/4 b - 1/2 b) Fb 1/EJ = 3/4 Fb^2/EJ$$

$$L_{CB}^{x_0} = \int_0^b (1 + 1/2 x/b - 3/2 x^2/b^2) Fb 1/EJ dx = [x + 1/4 x^2/b - 1/2 x^3/b^2]_0^b Fb 1/EJ$$

$$= (b + 1/4 b - 1/2 b) Fb 1/EJ = 3/4 Fb^2/EJ$$

$$L_{DE}^{x_0} = \int_0^b (3/2 x/b - 2 x^2/b^2 + 1/2 x^3/b^3) Fb 1/EJ dx = [3/4 x^2/b - 2/3 x^3/b^2 + 1/8 x^4/b^3]_0^b Fb 1/EJ$$

$$= (3/4 b - 2/3 b + 1/8 b) Fb 1/EJ = 5/24 Fb^2/EJ$$

$$L_{ED}^{x_0} = \int_0^b (x/b - 1/2 x^2/b^2 - 1/2 x^3/b^3) Fb 1/EJ dx = [1/2 x^2/b - 1/6 x^3/b^2 - 1/8 x^4/b^3]_0^b Fb 1/EJ$$

$$= (1/2 b - 1/6 b - 1/8 b) Fb 1/EJ = 5/24 Fb^2/EJ$$

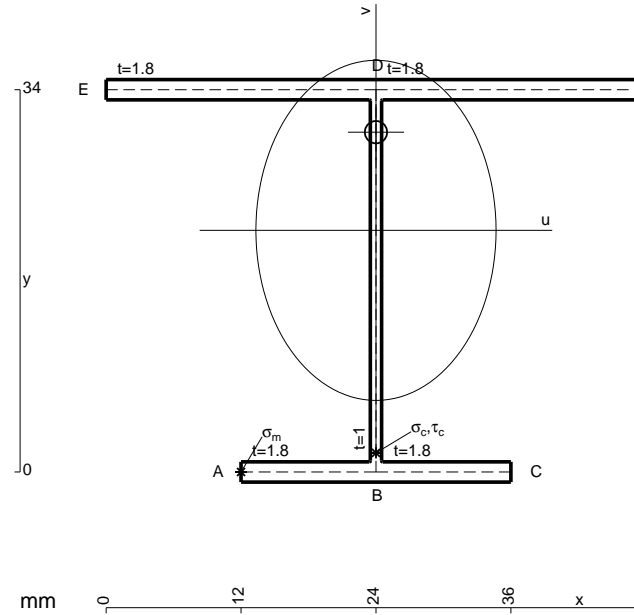

- A = 163.6 mm²
- J_u = 37433. mm⁴
- J_v = 18662. mm⁴
- J_i = 151.3 mm⁴
- y_o = 8.733 mm
- y_g = 21.49 mm
- N = -740. N
- T_y = -925. N
- M_x = -407000. Nmm
- x_m = 12. mm
- u_m = -12. mm
- v_m = -21.49 mm
- σ_m = N/A-Mv/J_u = -238.2 N/mm²
- x_c = 24. mm
- v_c = -21.49 mm
- σ_c = N/A-Mv/J_u = -238.2 N/mm²
- τ_c = TS'/tJ_u = 22.94 N/mm²
- τ_g = TS'/tJ_u = 22.94 N/mm²
- t_c = 370. mm
- σ_o = √σ²+3τ² = 241.5 N/mm²

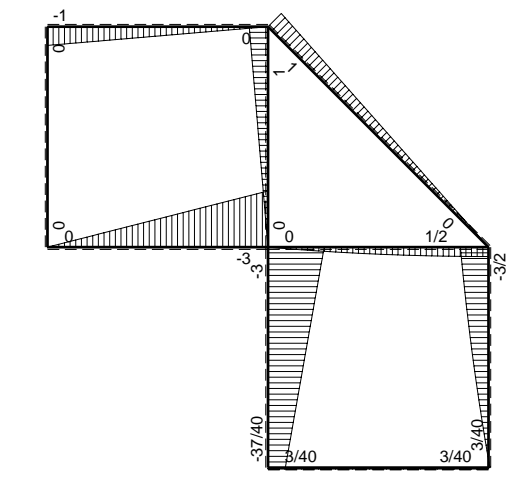
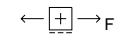
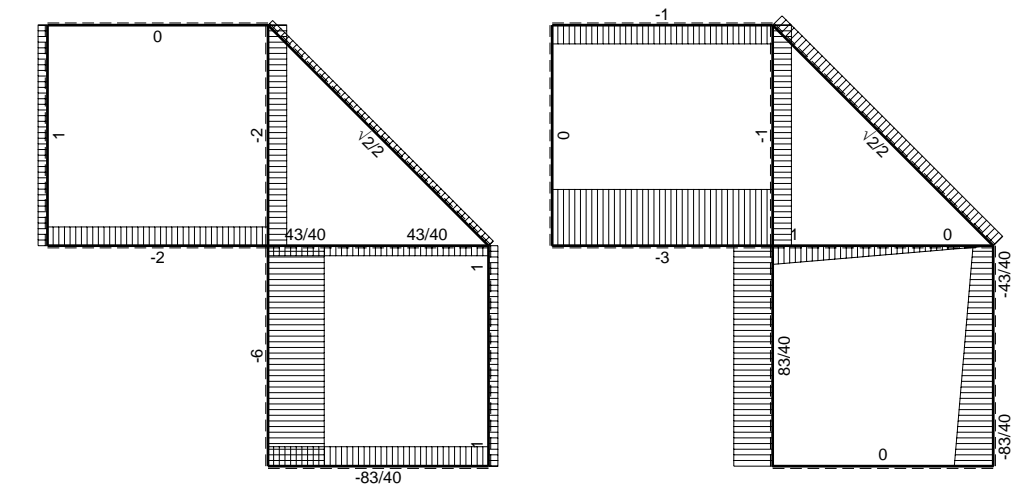
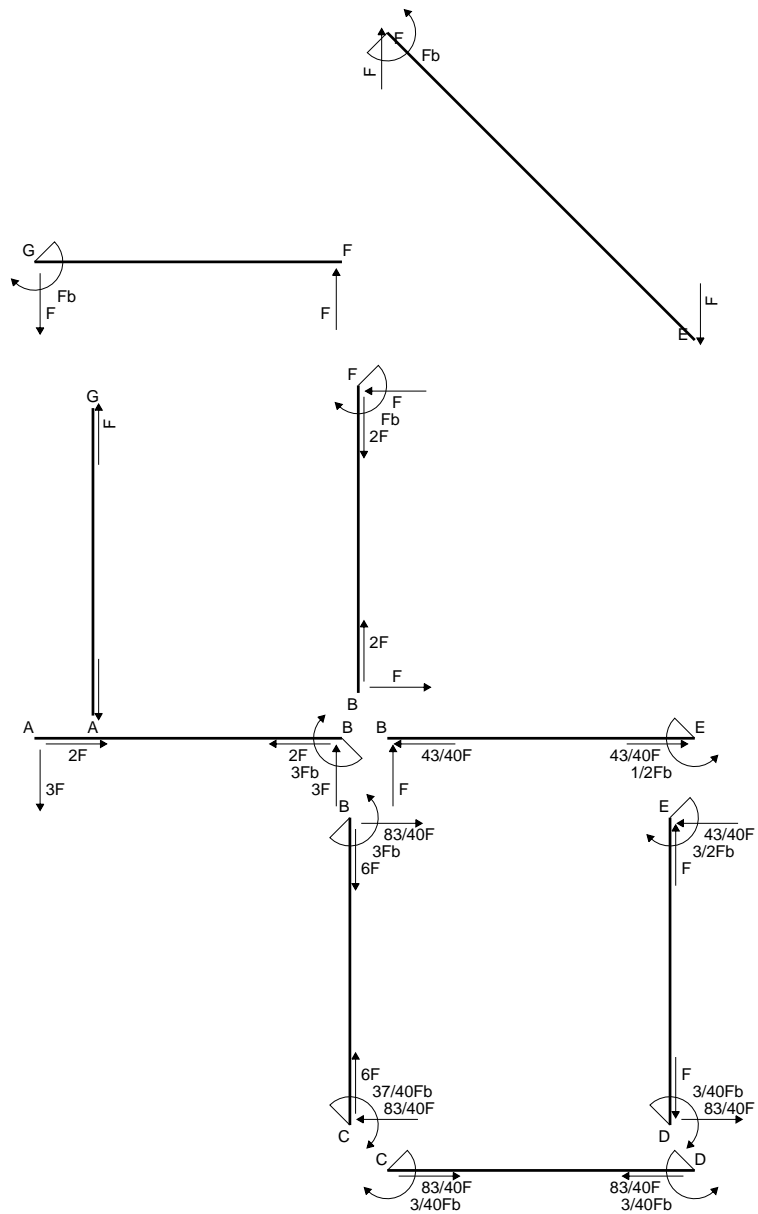

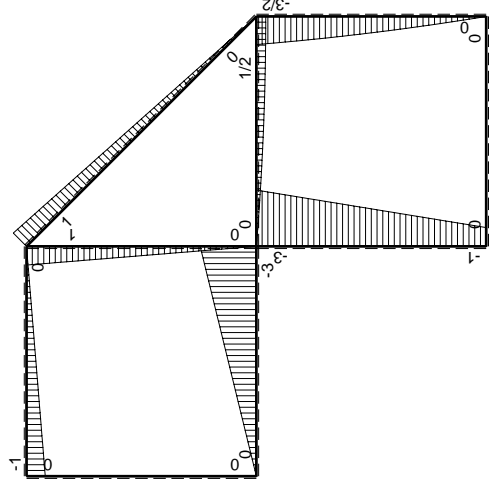
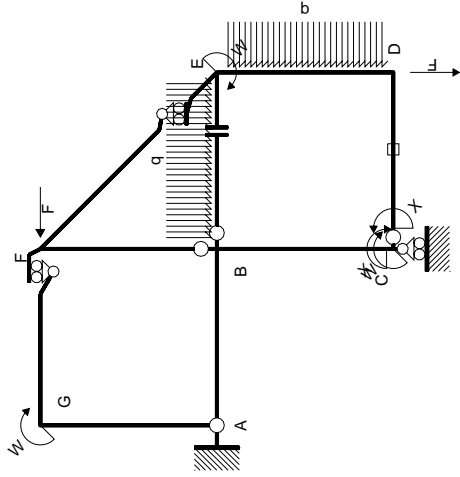

Schema di calcolo iperstatico

M_0 flessione da carichi assegnati

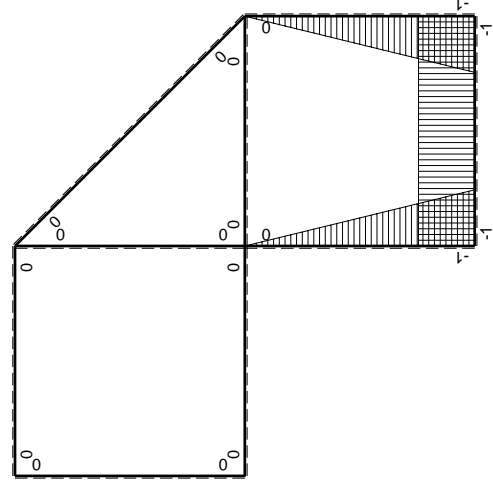

M_x flessione da iperstatica $X=1$

Quadro contribuiti PLV per iperstatica $X=W_{cd}$

\rightarrow	$M_x(x)$	$M_0(x)$	$M_x M_0$	$M_x M_x$	$\int M_x M_0 / EJ dx$	$\int M_x M_x / EJ dx$
AB b	0	-3Fx	0	0	0	0
BA b	0	3Fb-3Fx	0	0	0	0
BC b	-x/b	-3Fb+2Fx	3Fx-2Fx ² /b	x ² /b ²	5/6Fb ² /EJ	1/3Xb/EJ
CB b	1-x/b	Fb+2Fx	Fb+Fx-2Fx ² /b	1-2x/b+x ² /b ²	0	Xb/EJ
CD b	-1	0	0	1	0	Xb/EJ
DC b	1	0	0	1	0	Xb/EJ
DE b	-1+x/b	-2Fx+1/2qx ²	2Fx-5/2Fx ² /b+1/2qx ³ /b	1-2x/b+x ² /b ²	7/24Fb ² /EJ	1/3Xb/EJ
ED b	x/b	3/2Fb-Fx-1/2qx ²	3/2Fx-Fx ² /b-1/2qx ³ /b	x ² /b ²	0	0
EF $\sqrt{2}b$	0	$\sqrt{2}2Fx$	0	0	0	0
FG b	0	-Fx	0	0	0	0
GF b	0	Fb-Fx	0	0	0	0
GA b	0	0	0	0	0	0
AG b	0	0	0	0	0	0
FB b	0	Fb-Fx	0	0	0	0
BF b	0	-Fx	0	0	0	0
BE b	0	Fx-1/2qx ²	0	0	0	0
EB b	0	-1/2Fb+1/2qx ²	0	0	0	0
CD	elongazione asta $N_{1,cd} \epsilon_{cd} L_{cd}$				-Fb ² /EJ	
	totali				1/8Fb ² /EJ	5/3Xb/EJ
	iperstatica $X=W_{cd}$				-3/40Fb	

Sviluppi di calcolo iperstatica

$$L_{BC}^{xx} = \int_0^b (x^2/b^2) 1/EJ dx = [1/3 x^3/b^2]_0^b 1/EJ$$

$$= (1/3 b) 1/EJ = 1/3 b/EJ$$

$$L_{CB}^{xx} = \int_0^b (1 - 2x/b + x^2/b^2) 1/EJ dx = [x - x^2/b + 1/3 x^3/b^2]_0^b 1/EJ$$

$$= (b - b + 1/3 b) 1/EJ = 1/3 b/EJ$$

$$L_{CD}^{xx} = \int_0^b (1) 1/EJ dx = [x]_0^b 1/EJ$$

$$= (b) 1/EJ = b/EJ$$

$$L_{DC}^{xx} = \int_0^b (1) 1/EJ dx = [x]_0^b 1/EJ$$

$$= (b) 1/EJ = b/EJ$$

$$L_{DE}^{xx} = \int_0^b (1 - 2x/b + x^2/b^2) 1/EJ dx = [x - x^2/b + 1/3 x^3/b^2]_0^b 1/EJ$$

$$= (b - b + 1/3 b) 1/EJ = 1/3 b/EJ$$

$$L_{ED}^{xx} = \int_0^b (x^2/b^2) 1/EJ dx = [1/3 x^3/b^2]_0^b 1/EJ$$

$$= (1/3 b) 1/EJ = 1/3 b/EJ$$

$$L_{BC}^{xo} = \int_0^b (3x/b - 2x^2/b^2) Fb 1/EJ dx = [3/2 x^2/b - 2/3 x^3/b^2]_0^b Fb 1/EJ$$

$$= (3/2 b - 2/3 b) Fb 1/EJ = 5/6 Fb^2/EJ$$

$$L_{CB}^{xo} = \int_0^b (1 + x/b - 2x^2/b^2) Fb 1/EJ dx = [x + 1/2 x^2/b - 2/3 x^3/b^2]_0^b Fb 1/EJ$$

$$= (b + 1/2 b - 2/3 b) Fb 1/EJ = 5/6 Fb^2/EJ$$

$$L_{DE}^{xo} = \int_0^b (2x/b - 5/2 x^2/b^2 + 1/2 x^3/b^3) Fb 1/EJ dx = [x^2/b - 5/6 x^3/b^2 + 1/8 x^4/b^3]_0^b Fb 1/EJ$$

$$= (b - 5/6 b + 1/8 b) Fb 1/EJ = 7/24 Fb^2/EJ$$

$$L_{ED}^{xo} = \int_0^b (3/2 x/b - x^2/b^2 - 1/2 x^3/b^3) Fb 1/EJ dx = [3/4 x^2/b - 1/3 x^3/b^2 - 1/8 x^4/b^3]_0^b Fb 1/EJ$$

$$= (3/4 b - 1/3 b - 1/8 b) Fb 1/EJ = 7/24 Fb^2/EJ$$

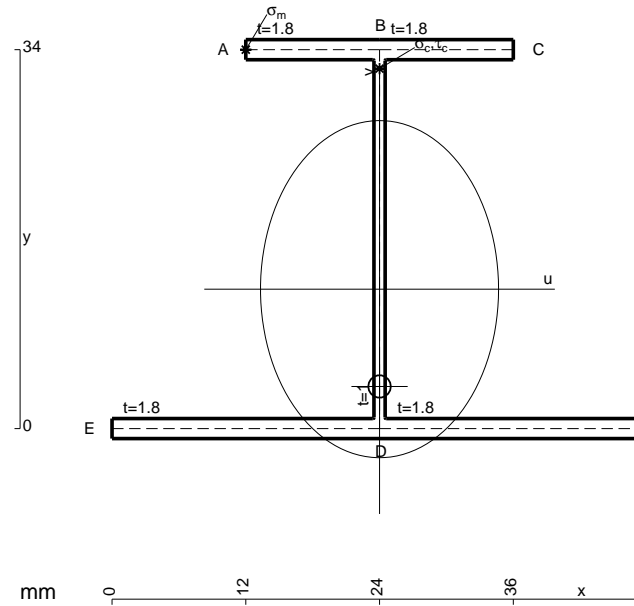

- A = 163.6 mm²
- J_u = 37433. mm⁴
- J_v = 18662. mm⁴
- J_t = 151.3 mm⁴
- y_o = -8.733 mm
- y_g = 12.51 mm
- N = -480. N
- T_y = -720. N
- M_x = -345600. Nmm
- x_m = 12. mm
- y_m = 34. mm
- u_m = -12. mm
- v_m = 21.49 mm
- σ_m = N/A-Mv/J_u = 195.5 N/mm²
- x_c = 24. mm
- y_c = 34. mm
- v_c = 21.49 mm
- σ_c = N/A-Mv/J_u = 195.5 N/mm²
- τ_c = TS'/tJ_u = 17.86 N/mm²
- τ_g = TS'/tJ_u = 17.86 N/mm²
- t_c = 240. mm
- σ_o = √σ²+3τ² = 197.9 N/mm²

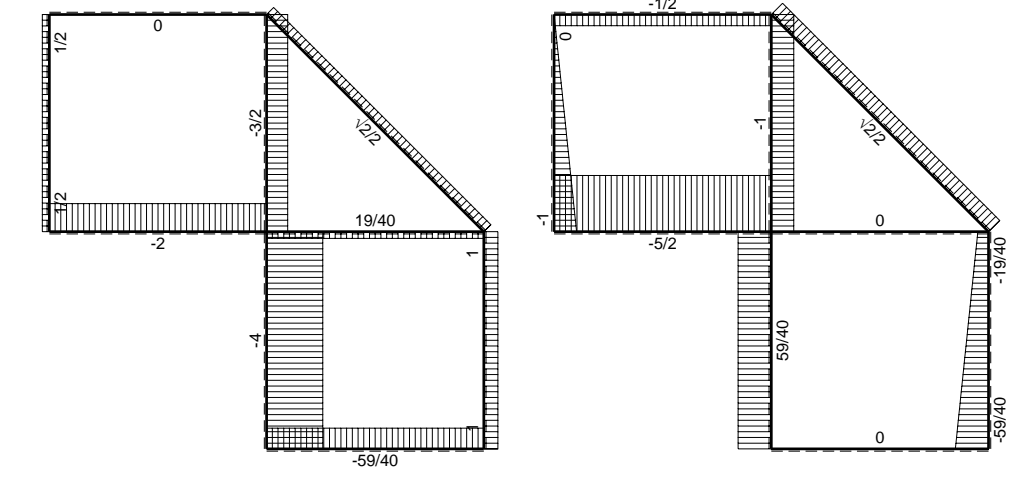
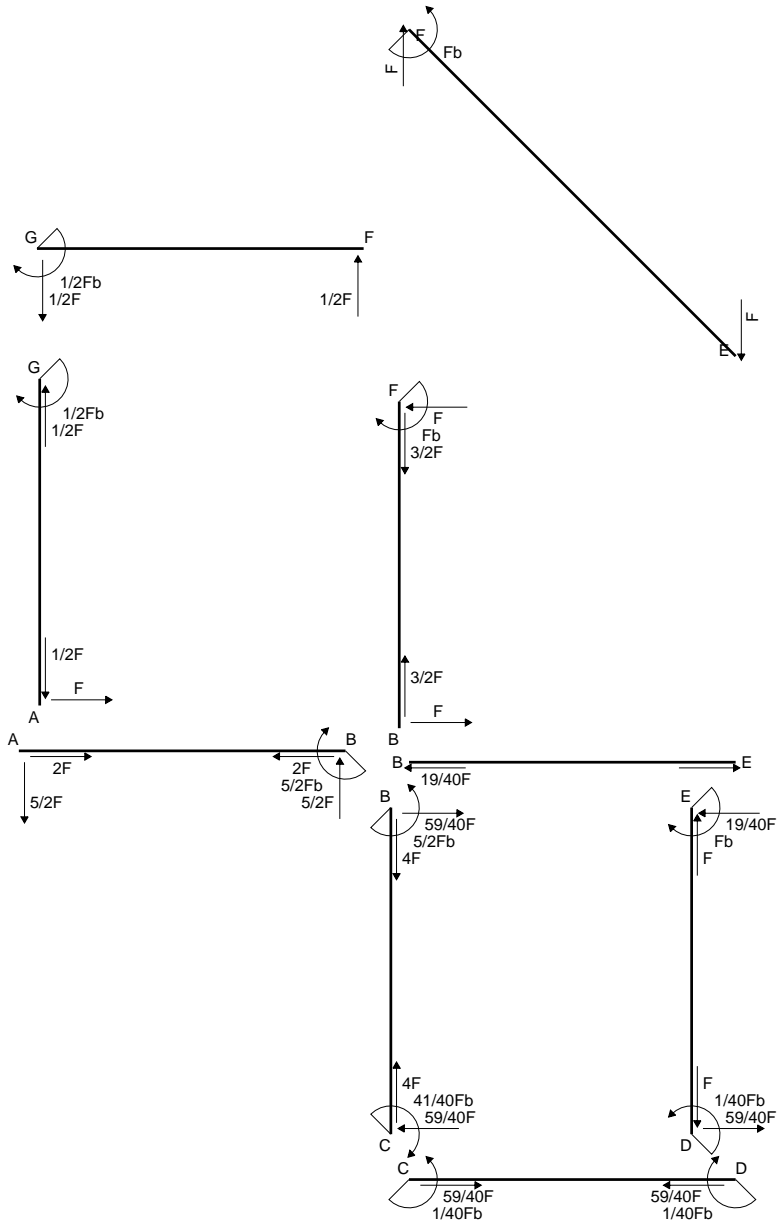

← ⊕ → F

↑ ⊕ ↓ F

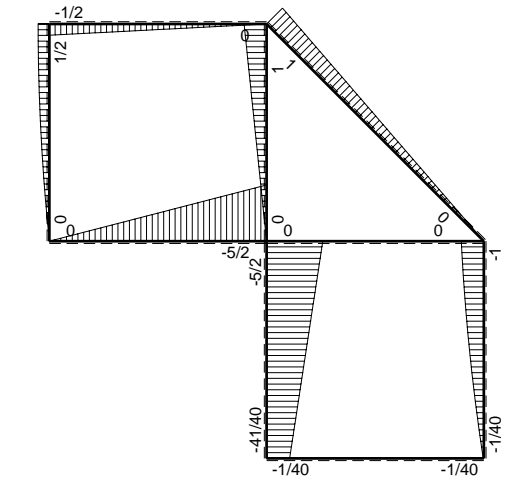

⊕ ⊖ F_b

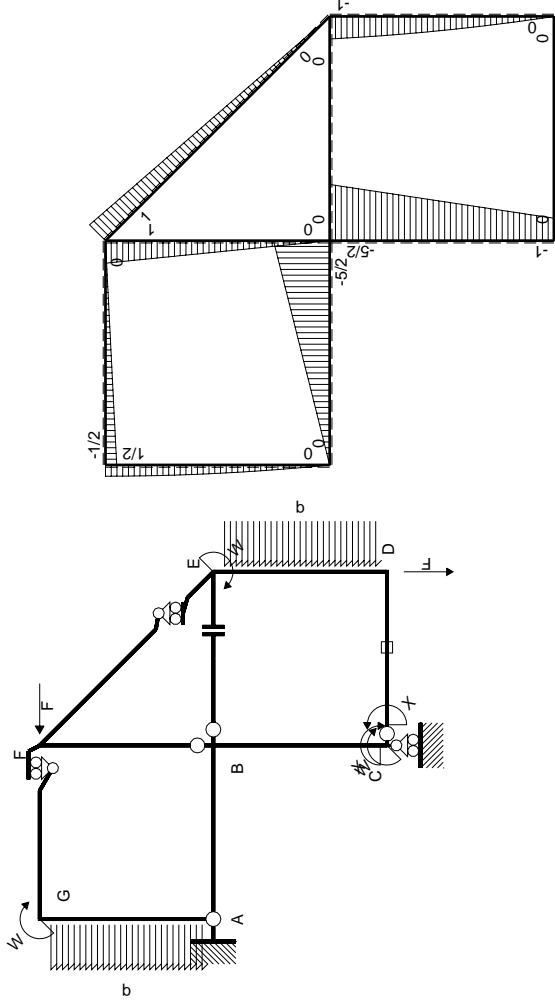

Schema di calcolo iperstatico

M_0 flessione da carichi assegnati

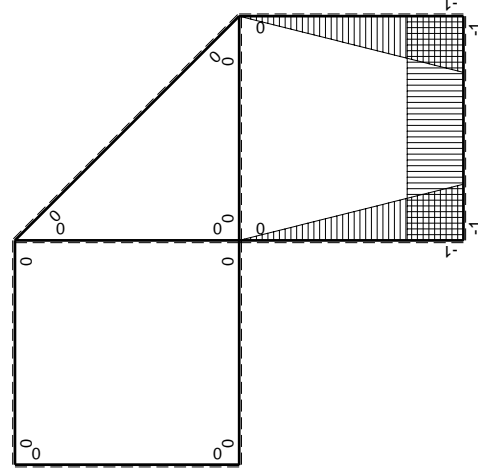

M_x flessione da iperstatica $X=1$

Quadro contribuiti PLV per iperstatica $X=W_{cd}$

\rightarrow	$M_x(x)$	$M_0(x)$	$M_x M_0$	$M_x M_x$	$\int M_x M_0 / EJ dx$	$\int M_x M_x / EJ dx$
AB b	0	$-5/2Fx$	0	0	0	0
BA b	0	$5/2Fb-5/2Fx$	0	0	0	0
BC b	$-x/b$	$-5/2Fb+3/2Fx$	$5/2Fx-3/2Fx^2/b$	x^2/b^2	$3/4Fb^2/EJ$	$1/3Xb/EJ$
CB b	$1-x/b$	$Fb+3/2Fx$	$Fb+1/2Fx-3/2Fx^2/b$	$1-2x/b+x^2/b^2$	0	Xb/EJ
CD b	-1	0	0	1	0	0
DC b	1	0	0	1	0	0
DE b	$-1+x/b$	$-3/2Fx+1/2qx^2$	$3/2Fx-2Fx^2/b+1/2qx^3/b$	$1-2x/b+x^2/b^2$	$5/24Fb^2/EJ$	$1/3Xb/EJ$
ED b	x/b	$Fb-1/2Fx-1/2qx^2$	$Fx-1/2Fx^2/b-1/2qx^3/b$	x^2/b^2	0	0
EF $\sqrt{2}b$	0	$\sqrt{2}/2Fx$	0	0	0	0
FG b	0	$-1/2Fx$	0	0	0	0
GF b	0	$1/2Fb-1/2Fx$	0	0	0	0
GA b	0	$1/2Fb-1/2qx^2$	0	0	0	0
AG b	0	$-Fx+1/2qx^2$	0	0	0	0
FB b	0	$Fb-Fx$	0	0	0	0
BF b	0	$-Fx$	0	0	0	0
BE b	0	0	0	0	0	0
EB b	0	0	0	0	0	0
CD	elongazione asta $N_{1,cd} \epsilon_{cd} L_{cd}$				$-Fb^2/EJ$	
	totali				$-1/24Fb^2/EJ$	$5/3Xb/EJ$
	iperstatica $X=W_{cd}$				$1/40Fb$	

Sviluppi di calcolo iperstatica

$$L_{BC}^{xx} = \int_0^b (x^2/b^2) 1/EJ dx = [1/3 x^3/b^2]_0^b 1/EJ$$

$$= (1/3 b) 1/EJ = 1/3 b/EJ$$

$$L_{CB}^{xx} = \int_0^b (1 - 2x/b + x^2/b^2) 1/EJ dx = [x - x^2/b + 1/3 x^3/b^2]_0^b 1/EJ$$

$$= (b - b + 1/3 b) 1/EJ = 1/3 b/EJ$$

$$L_{CD}^{xx} = \int_0^b (1) 1/EJ dx = [x]_0^b 1/EJ$$

$$= (b) 1/EJ = b/EJ$$

$$L_{DC}^{xx} = \int_0^b (1) 1/EJ dx = [x]_0^b 1/EJ$$

$$= (b) 1/EJ = b/EJ$$

$$L_{DE}^{xx} = \int_0^b (1 - 2x/b + x^2/b^2) 1/EJ dx = [x - x^2/b + 1/3 x^3/b^2]_0^b 1/EJ$$

$$= (b - b + 1/3 b) 1/EJ = 1/3 b/EJ$$

$$L_{ED}^{xx} = \int_0^b (x^2/b^2) 1/EJ dx = [1/3 x^3/b^2]_0^b 1/EJ$$

$$= (1/3 b) 1/EJ = 1/3 b/EJ$$

$$L_{BC}^{xo} = \int_0^b (5/2 x/b - 3/2 x^2/b^2) Fb 1/EJ dx = [5/4 x^2/b - 1/2 x^3/b^2]_0^b Fb 1/EJ$$

$$= (5/4 b - 1/2 b) Fb 1/EJ = 3/4 Fb^2/EJ$$

$$L_{CB}^{xo} = \int_0^b (1 + 1/2 x/b - 3/2 x^2/b^2) Fb 1/EJ dx = [x + 1/4 x^2/b - 1/2 x^3/b^2]_0^b Fb 1/EJ$$

$$= (b + 1/4 b - 1/2 b) Fb 1/EJ = 3/4 Fb^2/EJ$$

$$L_{DE}^{xo} = \int_0^b (3/2 x/b - 2 x^2/b^2 + 1/2 x^3/b^3) Fb 1/EJ dx = [3/4 x^2/b - 2/3 x^3/b^2 + 1/8 x^4/b^3]_0^b Fb 1/EJ$$

$$= (3/4 b - 2/3 b + 1/8 b) Fb 1/EJ = 5/24 Fb^2/EJ$$

$$L_{ED}^{xo} = \int_0^b (x/b - 1/2 x^2/b^2 - 1/2 x^3/b^3) Fb 1/EJ dx = [1/2 x^2/b - 1/6 x^3/b^2 - 1/8 x^4/b^3]_0^b Fb 1/EJ$$

$$= (1/2 b - 1/6 b - 1/8 b) Fb 1/EJ = 5/24 Fb^2/EJ$$

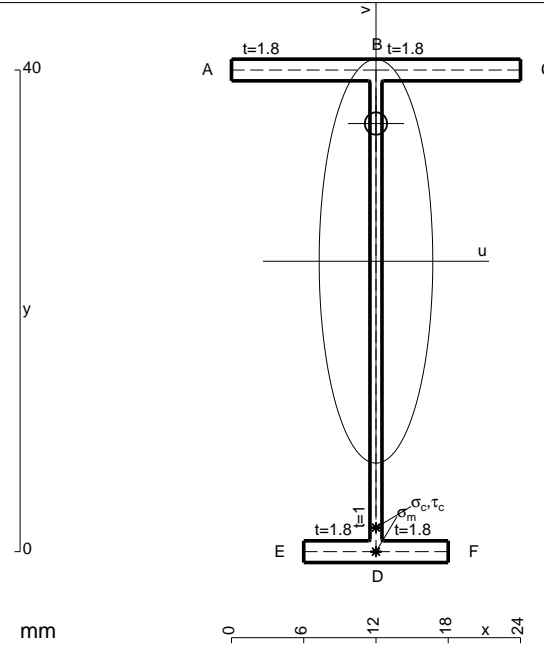

- A = 104.8 mm²
- J_u = 29473. mm⁴
- J_v = 2333. mm⁴
- J_I = 83.32 mm⁴
- y_o = 11.43 mm
- y_g = 24.12 mm
- N = -320. N
- T_y = -400. N
- M_x = -240000. Nmm
- x_m = 12. mm
- v_m = -24.12 mm
- σ_m = N/A - Mv/J_u = -199.5 N/mm²
- y_c = 3. mm
- u_c = -12. mm
- v_c = -21.12 mm
- σ_c = N/A - Mv/J_u = -199.5 N/mm²
- τ_c = TS'/tJ_u = 7.071 N/mm²
- τ_g = TS'/tJ_u = 7.071 N/mm²
- t_c = 160. mm
- σ_o = √σ² + 3τ² = 199.9 N/mm²

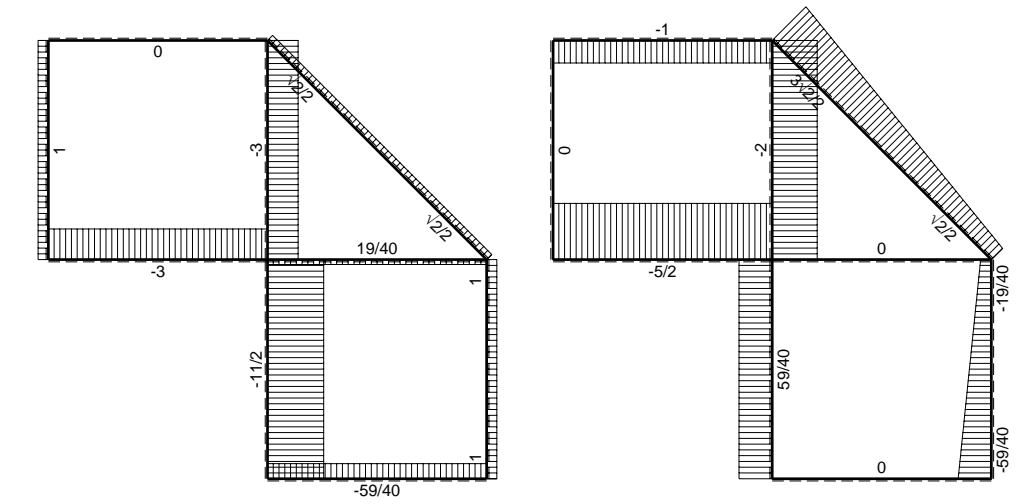
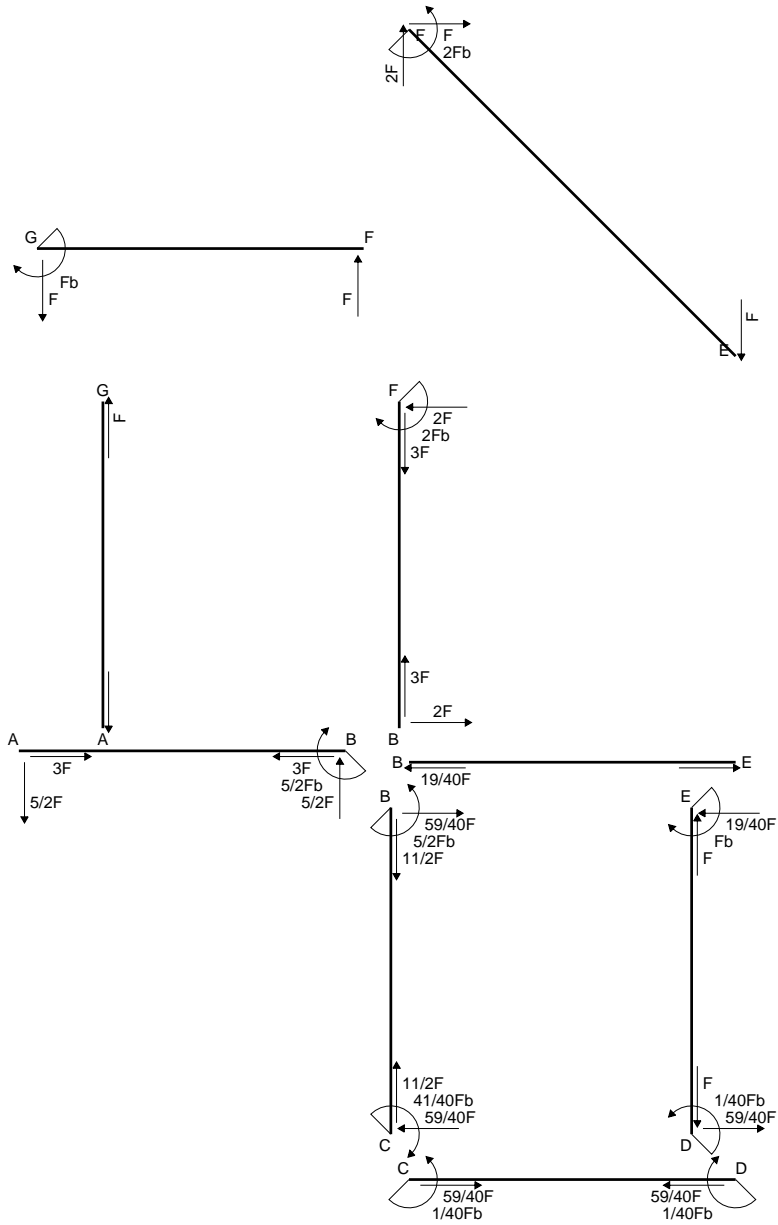

← ⊕ → F

↑ ⊕ ↓ F

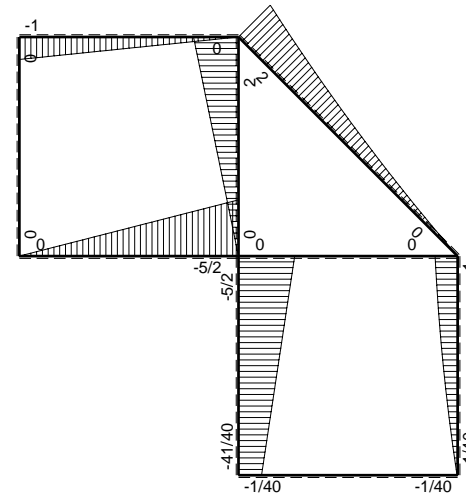

⊕ ⊖ F_b

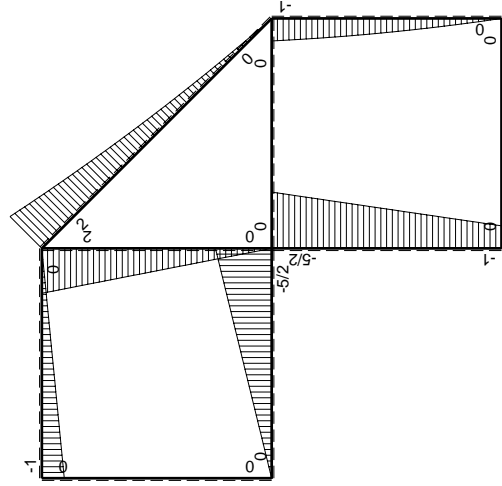
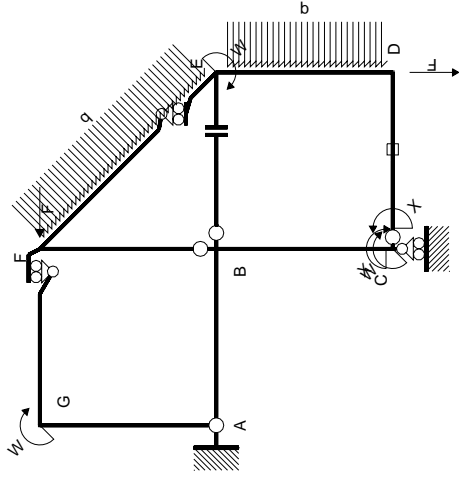

Schema di calcolo iperstatico

M_0 flessione da carichi assegnati

Quadro contribuiti PLV per iperstatica $X=W_{cd}$

\rightarrow	$M_x(x)$	$M_0(x)$	$M_x M_0$	$M_x M_x$	$\int M_x M_0 / EJ dx$	$\int M_x M_x / EJ dx$
AB b	0	-5/2Fx	0	0	0	0
BA b	0	5/2Fb-5/2Fx	0	0	0	0
BC b	-x/b	-5/2Fb+3/2Fx	5/2Fx-3/2Fx ² /b	x ² /b ²	3/4Fb ² /EJ	1/3Xb/EJ
CB b	1-x/b	Fb+3/2Fx	Fb+1/2Fx-3/2Fx ² /b	1-2x/b+x ² /b ²	0	Xb/EJ
CD b	-1	0	0	1	0	0
DC b	1	0	0	1	0	0
DE b	-1+x/b	-3/2Fx+1/2qx ²	3/2Fx-2Fx ² /b+1/2qx ³ /b	1-2x/b+x ² /b ²	5/24Fb ² /EJ	1/3Xb/EJ
ED b	x/b	Fb-1/2Fx-1/2qx ²	Fx-1/2Fx ² /b-1/2qx ³ /b	x ² /b ²	0	0
EF $\sqrt{2}b$	0	$\sqrt{2}Fx+1/2qx^2$	0	0	0	0
FG b	0	-Fx	0	0	0	0
GF b	0	Fb-Fx	0	0	0	0
GA b	0	0	0	0	0	0
AG b	0	0	0	0	0	0
FB b	0	2Fb-2Fx	0	0	0	0
BF b	0	-2Fx	0	0	0	0
BE b	0	0	0	0	0	0
EB b	0	0	0	0	0	0
CD	elongazione asta $N_{1,cd} \epsilon_{cd} L_{cd}$				-Fb ² /EJ	
	totali				-1/24Fb ² /EJ	5/3Xb/EJ
	iperstatica $X=W_{cd}$				1/40Fb	

Sviluppi di calcolo iperstatica

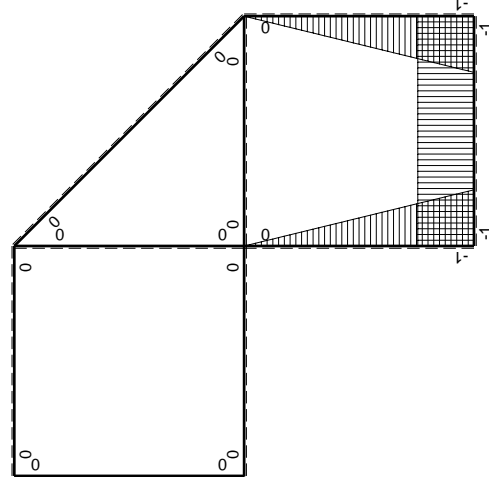

M_x flessione da iperstatica $X=1$

$$L_{BC}^{xx} = \int_0^b (x^2/b^2) 1/EJ dx = [1/3 x^3/b^2]_0^b 1/EJ$$

$$= (1/3 b) 1/EJ = 1/3 b/EJ$$

$$L_{CB}^{xx} = \int_0^b (1 - 2x/b + x^2/b^2) 1/EJ dx = [x - x^2/b + 1/3 x^3/b^2]_0^b 1/EJ$$

$$= (b - b + 1/3 b) 1/EJ = 1/3 b/EJ$$

$$L_{CD}^{xx} = \int_0^b (1) 1/EJ dx = [x]_0^b 1/EJ$$

$$= (b) 1/EJ = b/EJ$$

$$L_{DC}^{xx} = \int_0^b (1) 1/EJ dx = [x]_0^b 1/EJ$$

$$= (b) 1/EJ = b/EJ$$

$$L_{DE}^{xx} = \int_0^b (1 - 2x/b + x^2/b^2) 1/EJ dx = [x - x^2/b + 1/3 x^3/b^2]_0^b 1/EJ$$

$$= (b - b + 1/3 b) 1/EJ = 1/3 b/EJ$$

$$L_{ED}^{xx} = \int_0^b (x^2/b^2) 1/EJ dx = [1/3 x^3/b^2]_0^b 1/EJ$$

$$= (1/3 b) 1/EJ = 1/3 b/EJ$$

$$L_{BC}^{xo} = \int_0^b (5/2 x/b - 3/2 x^2/b^2) Fb 1/EJ dx = [5/4 x^2/b - 1/2 x^3/b^2]_0^b Fb 1/EJ$$

$$= (5/4 b - 1/2 b) Fb 1/EJ = 3/4 Fb^2/EJ$$

$$L_{CB}^{xo} = \int_0^b (1 + 1/2 x/b - 3/2 x^2/b^2) Fb 1/EJ dx = [x + 1/4 x^2/b - 1/2 x^3/b^2]_0^b Fb 1/EJ$$

$$= (b + 1/4 b - 1/2 b) Fb 1/EJ = 3/4 Fb^2/EJ$$

$$L_{DE}^{xo} = \int_0^b (3/2 x/b - 2 x^2/b^2 + 1/2 x^3/b^3) Fb 1/EJ dx = [3/4 x^2/b - 2/3 x^3/b^2 + 1/8 x^4/b^3]_0^b Fb 1/EJ$$

$$= (3/4 b - 2/3 b + 1/8 b) Fb 1/EJ = 5/24 Fb^2/EJ$$

$$L_{ED}^{xo} = \int_0^b (x/b - 1/2 x^2/b^2 - 1/2 x^3/b^3) Fb 1/EJ dx = [1/2 x^2/b - 1/6 x^3/b^2 - 1/8 x^4/b^3]_0^b Fb 1/EJ$$

$$= (1/2 b - 1/6 b - 1/8 b) Fb 1/EJ = 5/24 Fb^2/EJ$$

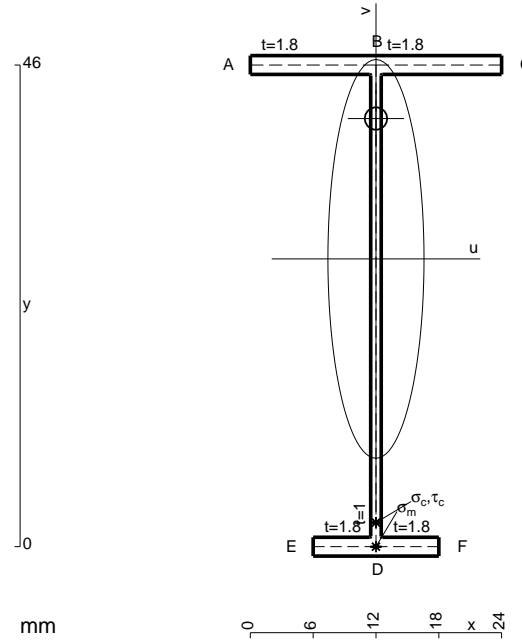

- A = 110.8 mm²
- J_u = 40163. mm⁴
- J_v = 2333. mm⁴
- J_i = 85.32 mm⁴
- y_o = 13.41 mm
- y_g = 27.48 mm
- N = -510. N
- T_y = -425. N
- M_x = -310250. Nmm
- x_m = 12. mm
- v_m = -27.48 mm
- σ_m = N/A - Mv/J_u = -216.9 N/mm²
- y_c = 3. mm
- u_c = -12. mm
- v_c = -24.48 mm
- σ_c = N/A - Mv/J_u = -216.9 N/mm²
- τ_c = TS'/tJ_u = 6.282 N/mm²
- τ_g = TS'/tJ_u = 6.282 N/mm²
- t_c = 170. mm
- σ_o = √σ² + 3τ² = 217.2 N/mm²

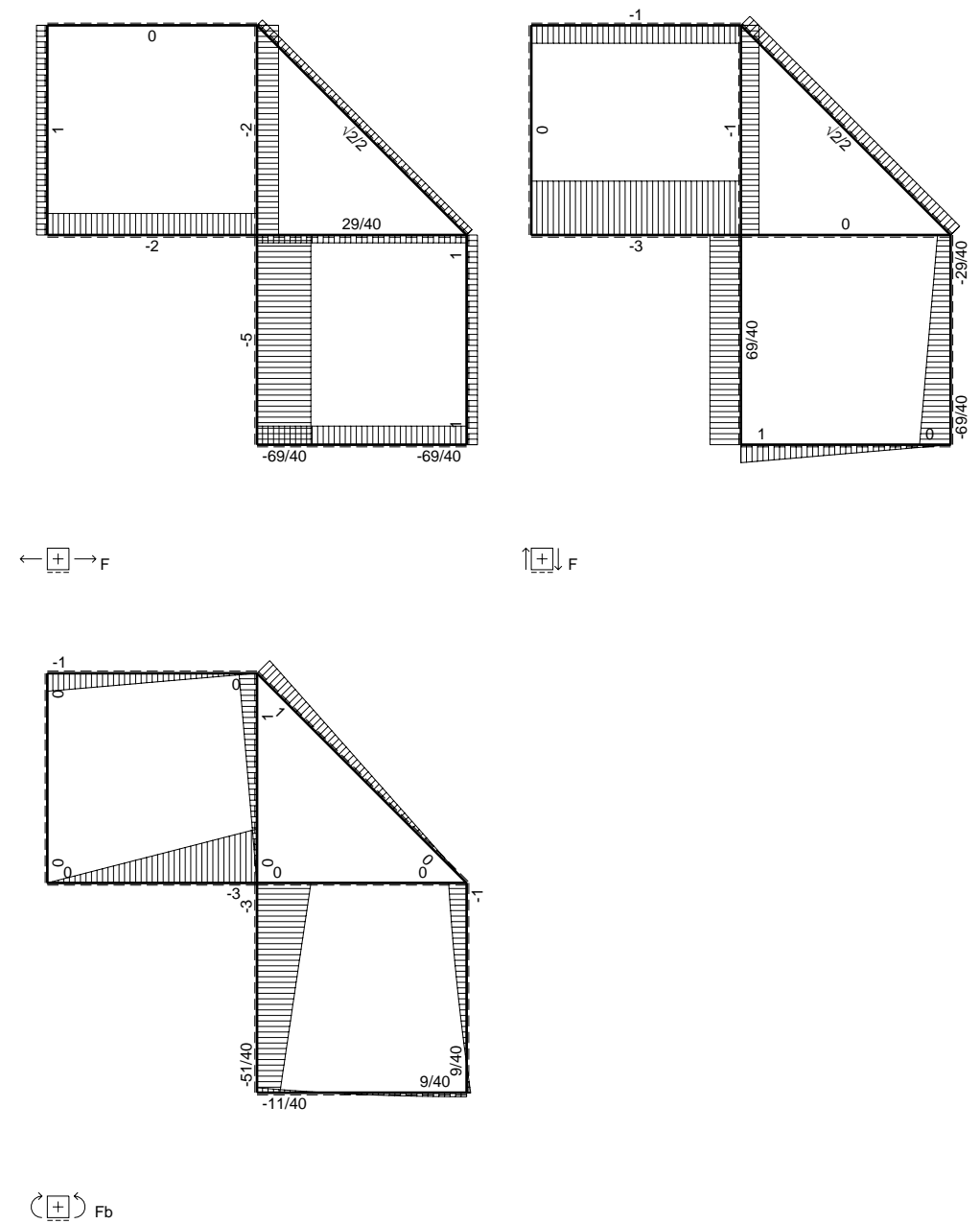
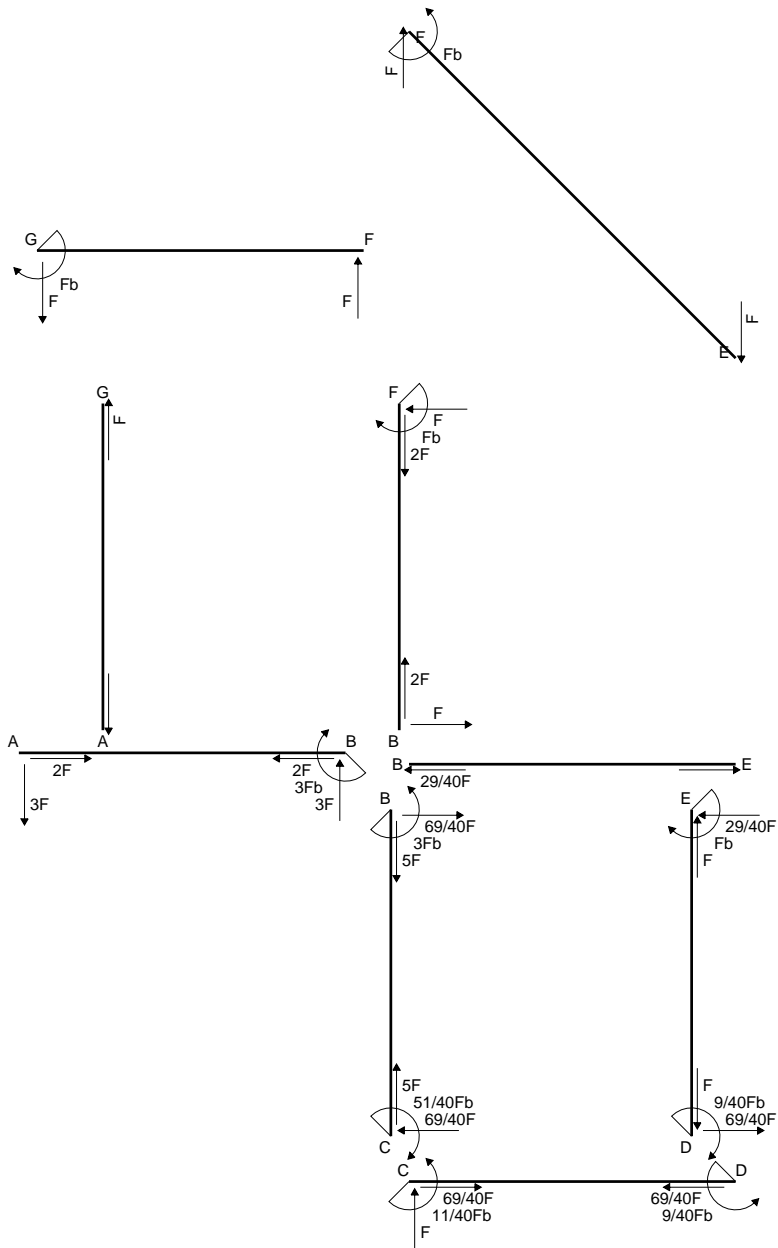

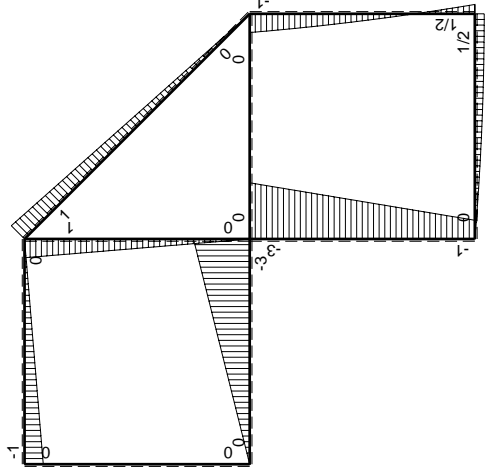
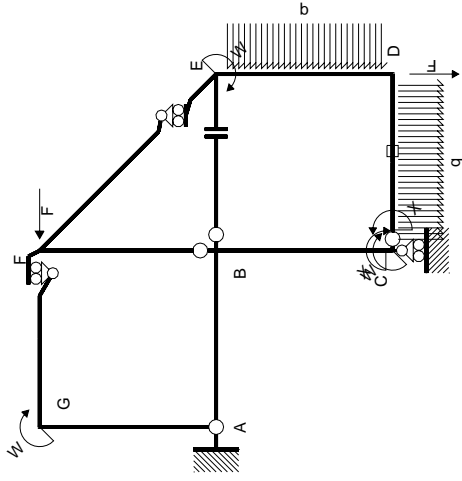

Schema di calcolo iperstatico

M_0 flessione da carichi assegnati

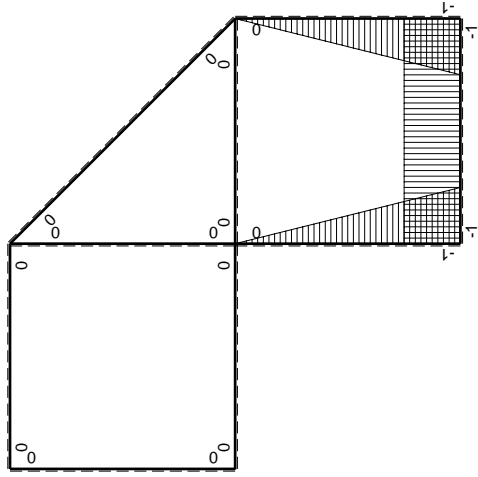

M_x flessione da iperstatica $X=1$

Quadro contributi PLV per iperstatica $X=W_{CD}$

→	$M_x(x)$	$M_o(x)$	$M_x M_o$	$M_x M_x$	$\int M_x M_o / EJ dx$	$\int X M_x M_x / EJ dx$
AB b	0	-3Fx	0	0	0	0
BA b	0	3Fb-3Fx	0	0	0	0
BC b	-x/b	-3Fb+2Fx	$3Fx-2Fx^2/b$	x^2/b^2	$5/6Fb^2/EJ$	$1/3Xb/EJ$
CB b	1-x/b	Fb+2Fx	$Fb+Fx-2Fx^2/b$	$1-2x/b+x^2/b^2$		
CD b	-1	$Fx-1/2qx^2$	$-Fx+1/2Fx^2/b$	1	$-1/3Fb^2/EJ$	Xb/EJ
DC b	1	$-1/2Fb+1/2qx^2$	$-1/2Fb+1/2Fx^2/b$	1		
DE b	-1+x/b	$1/2Fb-2Fx+1/2qx^2$	$-1/2Fb+5/2Fx-5/2Fx^2/b+1/2qx^3/b$	$1-2x/b+x^2/b^2$	$1/24Fb^2/EJ$	$1/3Xb/EJ$
ED b	x/b	$Fb-Fx-1/2qx^2$	$Fx-Fx^2/b-1/2qx^3/b$	x^2/b^2		
EF $\sqrt{2}b$	0	$\sqrt{2}/2Fx$	0	0	0	0
FG b	0	-Fx	0	0	0	0
GF b	0	Fb-Fx	0	0	0	0
GA b	0	0	0	0	0	0
AG b	0	0	0	0	0	0
FB b	0	Fb-Fx	0	0	0	0
BF b	0	-Fx	0	0	0	0
BE b	0	0	0	0	0	0
EB b	0	0	0	0	0	0
CD	elongazione asta $N_{1CD} \epsilon_{CD} L_{CD}$				$-Fb^2/EJ$	
	totali				$-11/24Fb^2/EJ$	$5/3Xb/EJ$
	iperstatica $X=W_{CD}$				$11/40Fb$	

Sviluppi di calcolo iperstatica

$$L_{BC}^{xx} = \int_0^b (x^2/b^2) 1/EJ dx = [1/3 x^3/b^2]_0^b 1/EJ$$

$$= (1/3 b) 1/EJ = 1/3 b/EJ$$

$$L_{CB}^{xx} = \int_0^b (1 - 2x/b + x^2/b^2) 1/EJ dx = [x - x^2/b + 1/3 x^3/b^2]_0^b 1/EJ$$

$$= (b - b + 1/3 b) 1/EJ = 1/3 b/EJ$$

$$L_{CD}^{xx} = \int_0^b (1) 1/EJ dx = [x]_0^b 1/EJ$$

$$= (b) 1/EJ = b/EJ$$

$$L_{DC}^{xx} = \int_0^b (1) 1/EJ dx = [x]_0^b 1/EJ$$

$$= (b) 1/EJ = b/EJ$$

$$L_{DE}^{xx} = \int_0^b (1 - 2x/b + x^2/b^2) 1/EJ dx = [x - x^2/b + 1/3 x^3/b^2]_0^b 1/EJ$$

$$= (b - b + 1/3 b) 1/EJ = 1/3 b/EJ$$

$$L_{ED}^{xx} = \int_0^b (x^2/b^2) 1/EJ dx = [1/3 x^3/b^2]_0^b 1/EJ$$

$$= (1/3 b) 1/EJ = 1/3 b/EJ$$

$$L_{BC}^{x_0} = \int_0^b (3x/b - 2x^2/b^2) Fb 1/EJ dx = [3/2 x^2/b - 2/3 x^3/b^2]_0^b Fb 1/EJ$$

$$= (3/2 b - 2/3 b) Fb 1/EJ = 5/6 Fb^2/EJ$$

$$L_{CB}^{x_0} = \int_0^b (1 + x/b - 2x^2/b^2) Fb 1/EJ dx = [x + 1/2 x^2/b - 2/3 x^3/b^2]_0^b Fb 1/EJ$$

$$= (b + 1/2 b - 2/3 b) Fb 1/EJ = 5/6 Fb^2/EJ$$

$$L_{CD}^{x_0} = \int_0^b (-x/b + 1/2 x^2/b^2) Fb 1/EJ dx + 1 (-1) 1 Fb^2/EJ$$

$$= [-1/2 x^2/b + 1/6 x^3/b^2]_0^b Fb 1/EJ + 1 (-1) 1 Fb^2/EJ$$

$$= (-1/2 b + 1/6 b) Fb 1/EJ + 1 (-1) 1 Fb^2/EJ = -4/3 Fb^2/EJ$$

$$L_{DC}^{x_0} = \int_0^b (-1/2 + 1/2 x^2/b^2) Fb 1/EJ dx + 1 (-1) 1 Fb^2/EJ$$

$$= [-1/2 x + 1/6 x^3/b^2]_0^b Fb 1/EJ + 1 (-1) 1 Fb^2/EJ$$

$$= (-1/2 b + 1/6 b) Fb 1/EJ + 1 (-1) 1 Fb^2/EJ = -4/3 Fb^2/EJ$$

$$L_{DE}^{x_0} = \int_0^b (-1/2 + 5/2 x/b - 5/2 x^2/b^2 + 1/2 x^3/b^3) Fb 1/EJ dx$$

$$= [-1/2 x + 5/4 x^2/b - 5/6 x^3/b^2 + 1/8 x^4/b^3]_0^b Fb 1/EJ$$

$$= (-1/2 b + 5/4 b - 5/6 b + 1/8 b) Fb 1/EJ = 1/24 Fb^2/EJ$$

$$L_{ED}^{x_0} = \int_0^b (x/b - x^2/b^2 - 1/2 x^3/b^3) Fb 1/EJ dx = [1/2 x^2/b - 1/3 x^3/b^2 - 1/8 x^4/b^3]_0^b Fb 1/EJ$$

$$= (1/2 b - 1/3 b - 1/8 b) Fb 1/EJ = 1/24 Fb^2/EJ$$

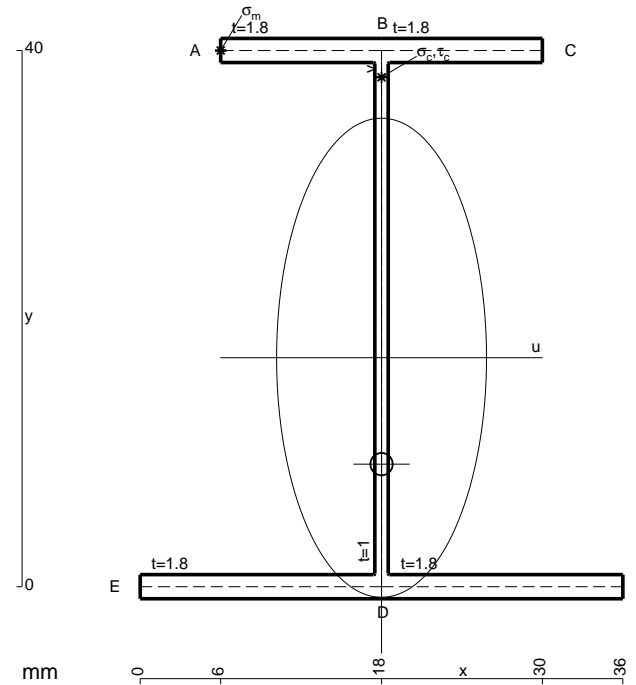

- A = 148. mm²
- J_u = 47272. mm⁴
- J_v = 9072. mm⁴
- J_t = 130. mm⁴
- y_o = -7.938 mm
- y_g = 17.08 mm
- N = -460. N
- T_y = -690. N
- M_x = -469200. Nmm
- x_m = 6. mm
- y_m = 40. mm
- u_m = -12. mm
- v_m = 22.92 mm
- σ_m = N/A-Mv/J_u = 224.4 N/mm²
- x_c = 18. mm
- y_c = 40. mm
- v_c = 22.92 mm
- σ_c = N/A-Mv/J_u = 224.4 N/mm²
- τ_c = TS'/J_u = 14.45 N/mm²
- τ_g = TS'/J_u = 14.45 N/mm²
- t_c = 230. mm
- σ_o = √(σ²+3τ²) = 225.8 N/mm²

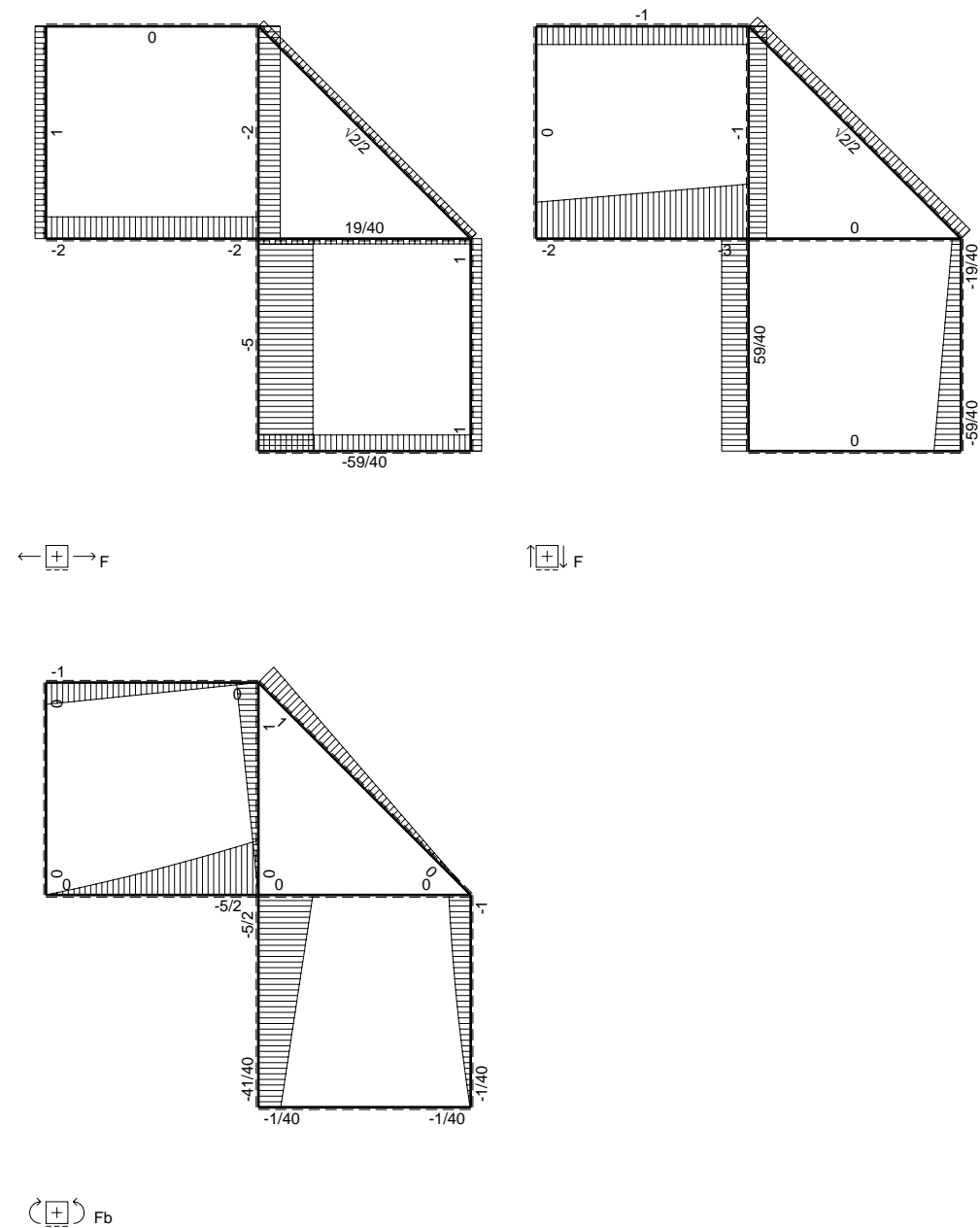
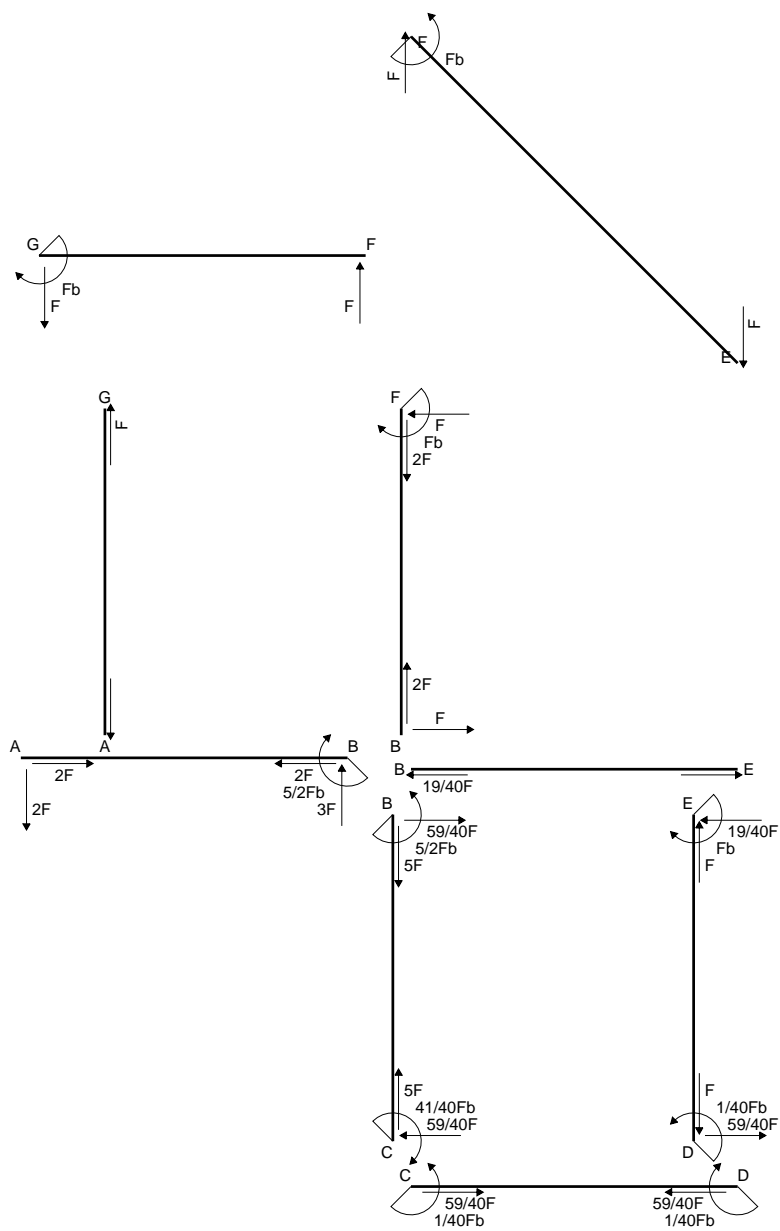

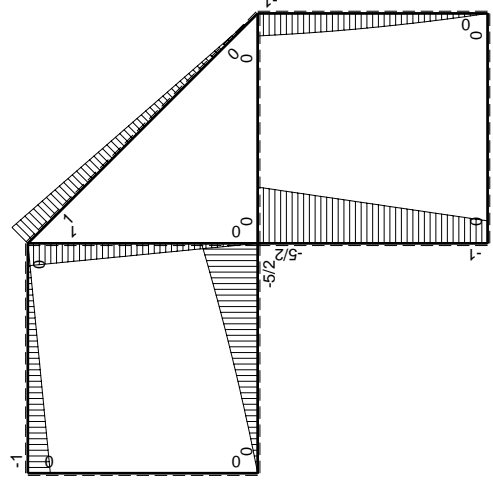
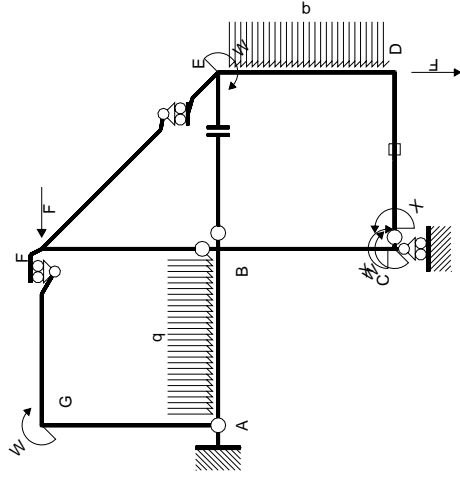

Schema di calcolo iperstatico

M_0 flessione da carichi assegnati

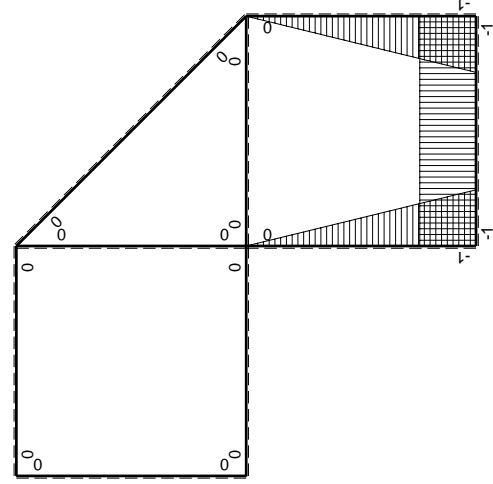

M_x flessione da iperstatica X=1

Quadro contributi PLV per iperstatica X=W_{CD}

→	$M_x(x)$	$M_0(x)$	$M_x M_0$	$M_x M_x$	$\int M_x M_0 / EJ dx$	$\int M_x M_x / EJ dx$
AB b	0	$-2Fx - 1/2qx^2$	0	0	0	0
BA b	0	$5/2Fb - 3Fx + 1/2qx^2$	0	0	0	0
BC b	$-x/b$	$-5/2Fb + 3/2Fx$	$5/2Fx - 3/2Fx^2/b$	x^2/b^2	$3/4Fb^2/EJ$	$1/3Xb/EJ$
CB b	$1-x/b$	$Fb + 3/2Fx$	$Fb + 1/2Fx - 3/2Fx^2/b$	$1 - 2x/b + x^2/b^2$	0	Xb/EJ
CD b	-1	0	0	1	0	0
DC b	1	0	0	1	0	0
DE b	$-1+x/b$	$-3/2Fx + 1/2qx^2$	$3/2Fx - 2Fx^2/b + 1/2qx^3/b$	$1 - 2x/b + x^2/b^2$	$5/24Fb^2/EJ$	$1/3Xb/EJ$
ED b	x/b	$Fb - 1/2Fx - 1/2qx^2$	$Fx - 1/2Fx^2/b - 1/2qx^3/b$	x^2/b^2	0	0
EF $\sqrt{2}b$	0	$\sqrt{2}/2Fx$	0	0	0	0
FG b	0	-Fx	0	0	0	0
GF b	0	$Fb - Fx$	0	0	0	0
GA b	0	0	0	0	0	0
AG b	0	0	0	0	0	0
FB b	0	$Fb - Fx$	0	0	0	0
BF b	0	-Fx	0	0	0	0
BE b	0	0	0	0	0	0
EB b	0	0	0	0	0	0
CD	elongazione asta $N_{1,CD} \epsilon_{CD} L_{CD}$				$-Fb^2/EJ$	
	totali				$-1/24Fb^2/EJ$	$5/3Xb/EJ$
	iperstatica X=W _{CD}				$1/40Fb$	

Sviluppi di calcolo iperstatica

$$L_{BC}^{xx} = \int_0^b (x^2/b^2) 1/EJ dx = [1/3 x^3/b^2]_0^b 1/EJ$$

$$= (1/3 b) 1/EJ = 1/3 b/EJ$$

$$L_{CB}^{xx} = \int_0^b (1 - 2x/b + x^2/b^2) 1/EJ dx = [x - x^2/b + 1/3 x^3/b^2]_0^b 1/EJ$$

$$= (b - b + 1/3 b) 1/EJ = 1/3 b/EJ$$

$$L_{CD}^{xx} = \int_0^b (1) 1/EJ dx = [x]_0^b 1/EJ$$

$$= (b) 1/EJ = b/EJ$$

$$L_{DC}^{xx} = \int_0^b (1) 1/EJ dx = [x]_0^b 1/EJ$$

$$= (b) 1/EJ = b/EJ$$

$$L_{DE}^{xx} = \int_0^b (1 - 2x/b + x^2/b^2) 1/EJ dx = [x - x^2/b + 1/3 x^3/b^2]_0^b 1/EJ$$

$$= (b - b + 1/3 b) 1/EJ = 1/3 b/EJ$$

$$L_{ED}^{xx} = \int_0^b (x^2/b^2) 1/EJ dx = [1/3 x^3/b^2]_0^b 1/EJ$$

$$= (1/3 b) 1/EJ = 1/3 b/EJ$$

$$L_{BC}^{xo} = \int_0^b (5/2 x/b - 3/2 x^2/b^2) Fb 1/EJ dx = [5/4 x^2/b - 1/2 x^3/b^2]_0^b Fb 1/EJ$$

$$= (5/4 b - 1/2 b) Fb 1/EJ = 3/4 Fb^2/EJ$$

$$L_{CB}^{xo} = \int_0^b (1 + 1/2 x/b - 3/2 x^2/b^2) Fb 1/EJ dx = [x + 1/4 x^2/b - 1/2 x^3/b^2]_0^b Fb 1/EJ$$

$$= (b + 1/4 b - 1/2 b) Fb 1/EJ = 3/4 Fb^2/EJ$$

$$L_{DE}^{xo} = \int_0^b (3/2 x/b - 2 x^2/b^2 + 1/2 x^3/b^3) Fb 1/EJ dx = [3/4 x^2/b - 2/3 x^3/b^2 + 1/8 x^4/b^3]_0^b Fb 1/EJ$$

$$= (3/4 b - 2/3 b + 1/8 b) Fb 1/EJ = 5/24 Fb^2/EJ$$

$$L_{ED}^{xo} = \int_0^b (x/b - 1/2 x^2/b^2 - 1/2 x^3/b^3) Fb 1/EJ dx = [1/2 x^2/b - 1/6 x^3/b^2 - 1/8 x^4/b^3]_0^b Fb 1/EJ$$

$$= (1/2 b - 1/6 b - 1/8 b) Fb 1/EJ = 5/24 Fb^2/EJ$$

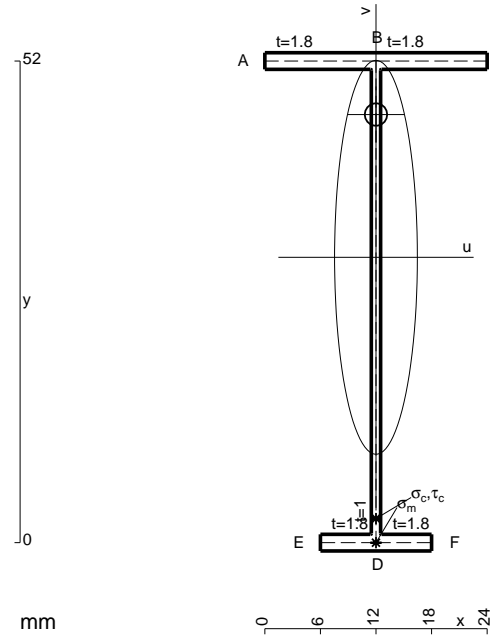

- A = 116.8 mm²
- J_u = 52822. mm⁴
- J_v = 2333. mm⁴
- J_t = 87.32 mm⁴
- y_o = 15.41 mm
- y_g = 30.81 mm
- N = -340. N
- T_y = -510. N
- M_x = -395250. Nmm
- x_m = 12. mm
- v_m = -30.81 mm
- σ_m = N/A-Mv/J_u = -233.4 N/mm²
- y_c = 3. mm
- u_c = -12. mm
- v_c = -27.81 mm
- σ_c = N/A-Mv/J_u = -233.4 N/mm²
- τ_c = TS^{*}/tJ_u = 6.425 N/mm²
- τ_g = TS^{*}/tJ_u = 6.425 N/mm²
- t_c = 170. mm
- σ_o = √σ²+3τ² = 233.7 N/mm²

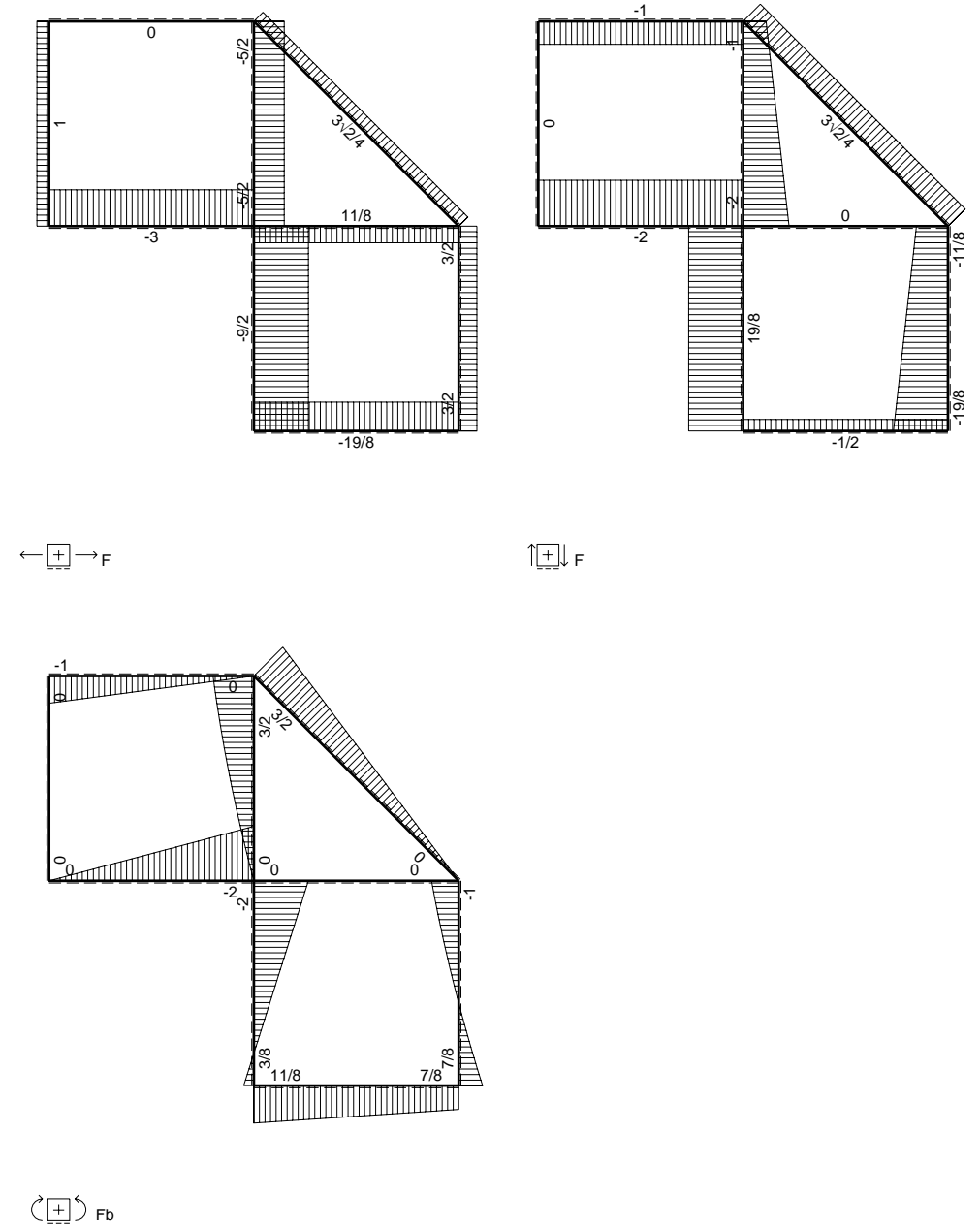
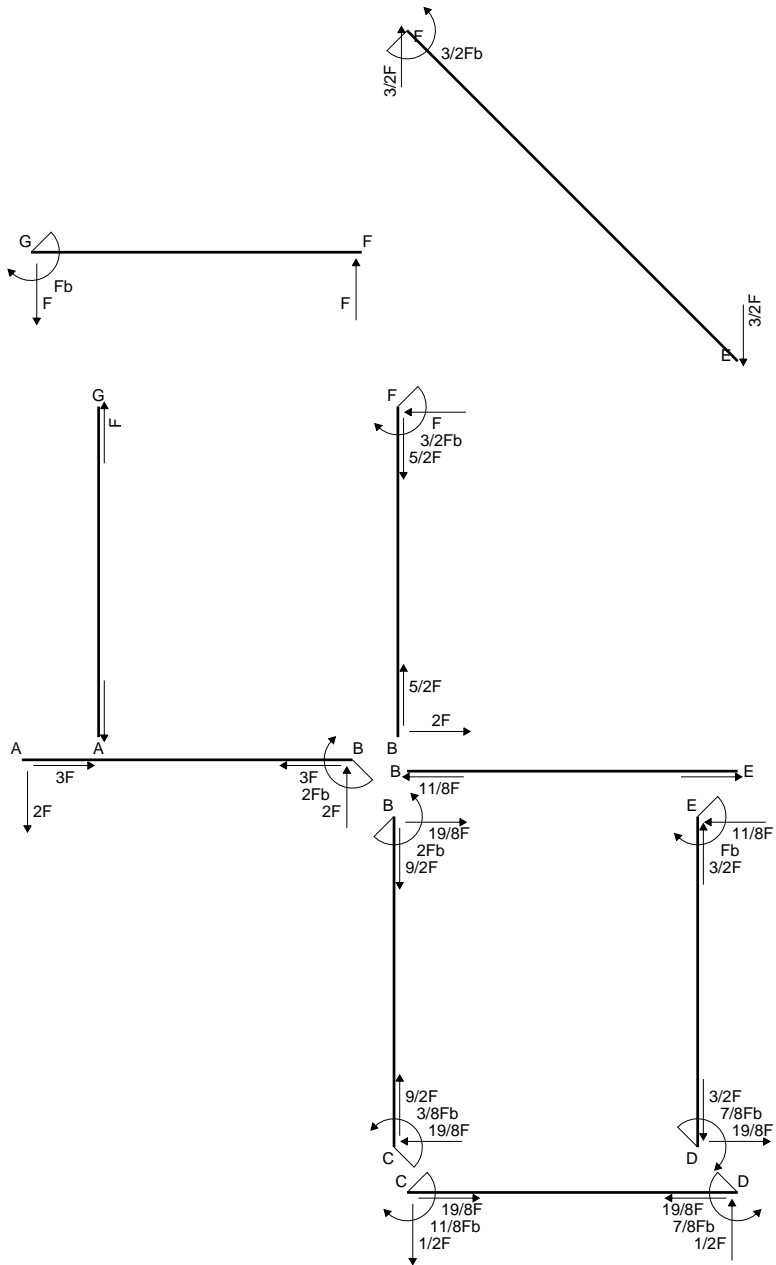

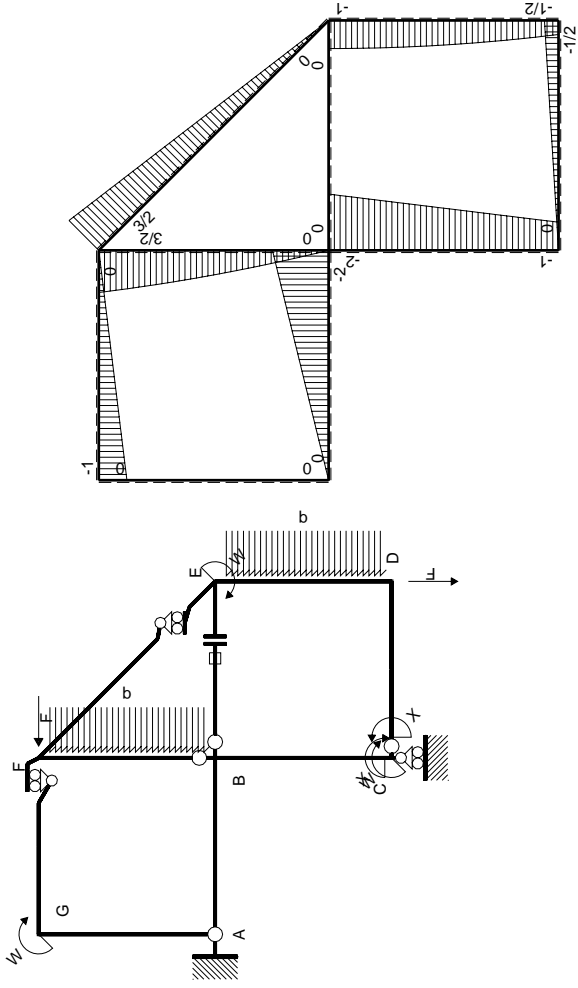

Schema di calcolo iperstatico

M_0 flessione da carichi assegnati

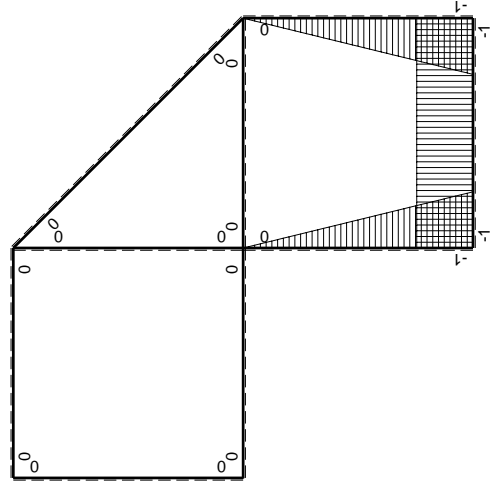

M_x flessione da iperstatica $X=1$

Quadro contributi PLV per iperstatica $X=W_{CD}$

→	$M_x(x)$	$M_o(x)$	$M_x M_o$	$M_x M_x$	$\int M_x M_o / EJ dx$	$\int X M_x M_x / EJ dx$
AB b	0	-2Fx	0	0	0	0
BA b	0	2Fb-2Fx	0	0		
BC b	-x/b	-2Fb+Fx	$2Fx-Fx^2/b$	x^2/b^2	$2/3Fb^2/EJ$	$1/3Xb/EJ$
CB b	1-x/b	Fb+Fx	$Fb-Fx^2/b$	$1-2x/b+x^2/b^2$		
CD b	-1	-1/2Fx	1/2Fx	1	$1/4Fb^2/EJ$	Xb/EJ
DC b	1	1/2Fb-1/2Fx	1/2Fb-1/2Fx	1		
DE b	-1+x/b	$-1/2Fb-Fx+1/2qx^2$	$1/2Fb+1/2Fx-3/2Fx^2/b+1/2qx^3/b$	$1-2x/b+x^2/b^2$	$3/8Fb^2/EJ$	$1/3Xb/EJ$
ED b	x/b	$Fb-1/2qx^2$	$Fx-1/2qx^3/b$	x^2/b^2		
EF $\sqrt{2}b$	0	$3\sqrt{2}/4Fx$	0	0	0	0
FG b	0	-Fx	0	0	0	0
GF b	0	Fb-Fx	0	0		
GA b	0	0	0	0	0	0
AG b	0	0	0	0		
FB b	0	$3/2Fb-Fx-1/2qx^2$	0	0	0	0
BF b	0	$-2Fx+1/2qx^2$	0	0		
BE b	0	0	0	0	0	0
EB b	0	0	0	0		
BE	elongazione asta $N_{1BE} \epsilon_{BE} L_{BE}$				Fb^2/EJ	
	totali				$55/24Fb^2/EJ$	$5/3Xb/EJ$
	iperstatica $X=W_{CD}$				$-11/8Fb$	

Sviluppi di calcolo iperstatica

$$L_{BC}^{xx} = \int_0^b (x^2/b^2) 1/EJ dx = [1/3 x^3/b^2]_0^b 1/EJ$$

$$= (1/3 b) 1/EJ = 1/3 b/EJ$$

$$L_{CB}^{xx} = \int_0^b (1 - 2x/b + x^2/b^2) 1/EJ dx = [x - x^2/b + 1/3 x^3/b^2]_0^b 1/EJ$$

$$= (b - b + 1/3 b) 1/EJ = 1/3 b/EJ$$

$$L_{CD}^{xx} = \int_0^b (1) 1/EJ dx = [x]_0^b 1/EJ$$

$$= (b) 1/EJ = b/EJ$$

$$L_{DC}^{xx} = \int_0^b (1) 1/EJ dx = [x]_0^b 1/EJ$$

$$= (b) 1/EJ = b/EJ$$

$$L_{DE}^{xx} = \int_0^b (1 - 2x/b + x^2/b^2) 1/EJ dx = [x - x^2/b + 1/3 x^3/b^2]_0^b 1/EJ$$

$$= (b - b + 1/3 b) 1/EJ = 1/3 b/EJ$$

$$L_{ED}^{xx} = \int_0^b (x^2/b^2) 1/EJ dx = [1/3 x^3/b^2]_0^b 1/EJ$$

$$= (1/3 b) 1/EJ = 1/3 b/EJ$$

$$L_{BC}^{x_0} = \int_0^b (2x/b - x^2/b^2) Fb 1/EJ dx = [x^2/b - 1/3 x^3/b^2]_0^b Fb 1/EJ$$

$$= (b - 1/3 b) Fb 1/EJ = 2/3 Fb^2/EJ$$

$$L_{CB}^{x_0} = \int_0^b (1 - x^2/b^2) Fb 1/EJ dx = [x - 1/3 x^3/b^2]_0^b Fb 1/EJ$$

$$= (b - 1/3 b) Fb 1/EJ = 2/3 Fb^2/EJ$$

$$L_{CD}^{x_0} = \int_0^b (1/2 x/b) Fb 1/EJ dx = [1/4 x^2/b]_0^b Fb 1/EJ$$

$$= (1/4 b) Fb 1/EJ = 1/4 Fb^2/EJ$$

$$L_{DC}^{x_0} = \int_0^b (1/2 - 1/2 x/b) Fb 1/EJ dx = [1/2 x - 1/4 x^2/b]_0^b Fb 1/EJ$$

$$= (1/2 b - 1/4 b) Fb 1/EJ = 1/4 Fb^2/EJ$$

$$L_{DE}^{x_0} = \int_0^b (1/2 + 1/2 x/b - 3/2 x^2/b^2 + 1/2 x^3/b^3) Fb 1/EJ dx$$

$$= [1/2 x + 1/4 x^2/b - 1/2 x^3/b^2 + 1/8 x^4/b^3]_0^b Fb 1/EJ$$

$$= (1/2 b + 1/4 b - 1/2 b + 1/8 b) Fb 1/EJ = 3/8 Fb^2/EJ$$

$$L_{ED}^{x_0} = \int_0^b (x/b - 1/2 x^3/b^3) Fb 1/EJ dx = [1/2 x^2/b - 1/8 x^4/b^3]_0^b Fb 1/EJ$$

$$= (1/2 b - 1/8 b) Fb 1/EJ = 3/8 Fb^2/EJ$$

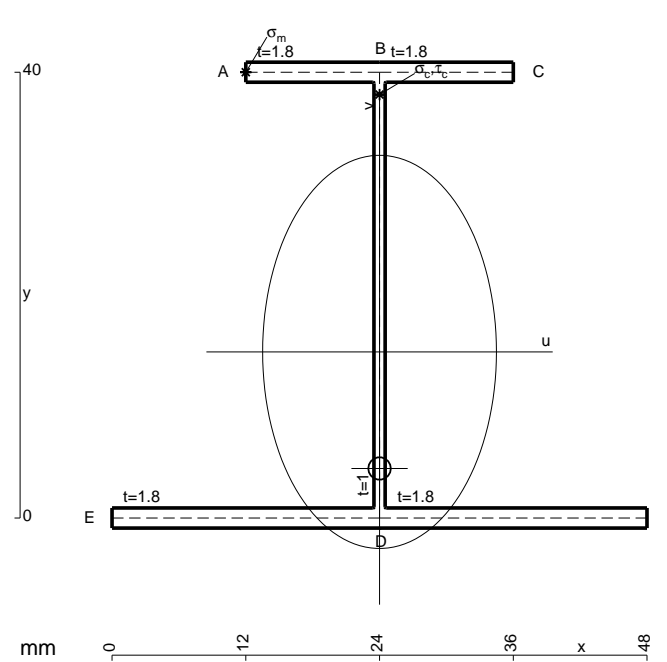

- A = 169.6 mm²
- J_u = 52772. mm⁴
- J_v = 18662. mm⁴
- J_t = 153.3 mm⁴
- y_o = -10.46 mm
- y_g = 14.91 mm
- N = -1740. N
- T_y = -1160. N
- M_x = -440800. Nmm
- x_m = 12. mm
- y_m = 40. mm
- u_m = -12. mm
- v_m = 25.09 mm
- σ_m = N/A-Mv/J_u = 199.4 N/mm²
- x_c = 24. mm
- y_c = 40. mm
- v_c = 25.09 mm
- σ_c = N/A-Mv/J_u = 199.4 N/mm²
- τ_c = TS_t/tJ_u = 23.83 N/mm²
- τ_g = TS_t/tJ_u = 23.83 N/mm²
- t_c = 580. mm
- σ_o = √σ²+3τ² = 203.6 N/mm²

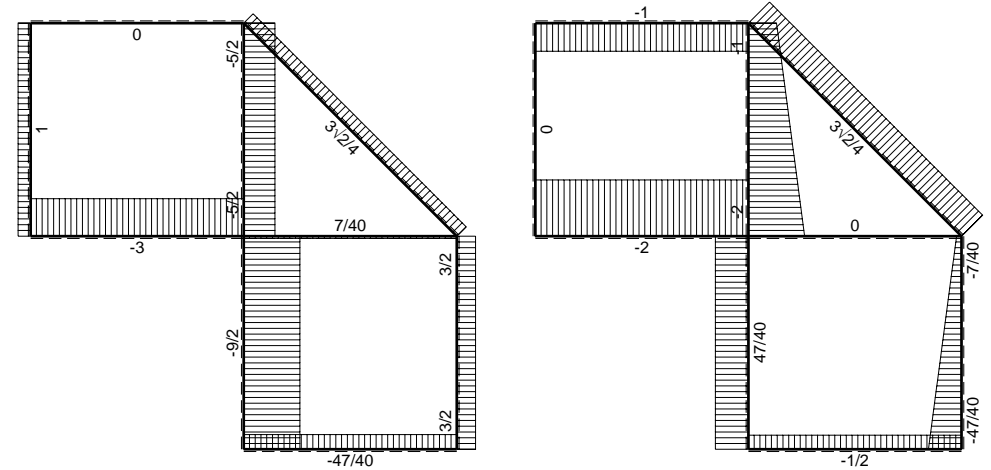
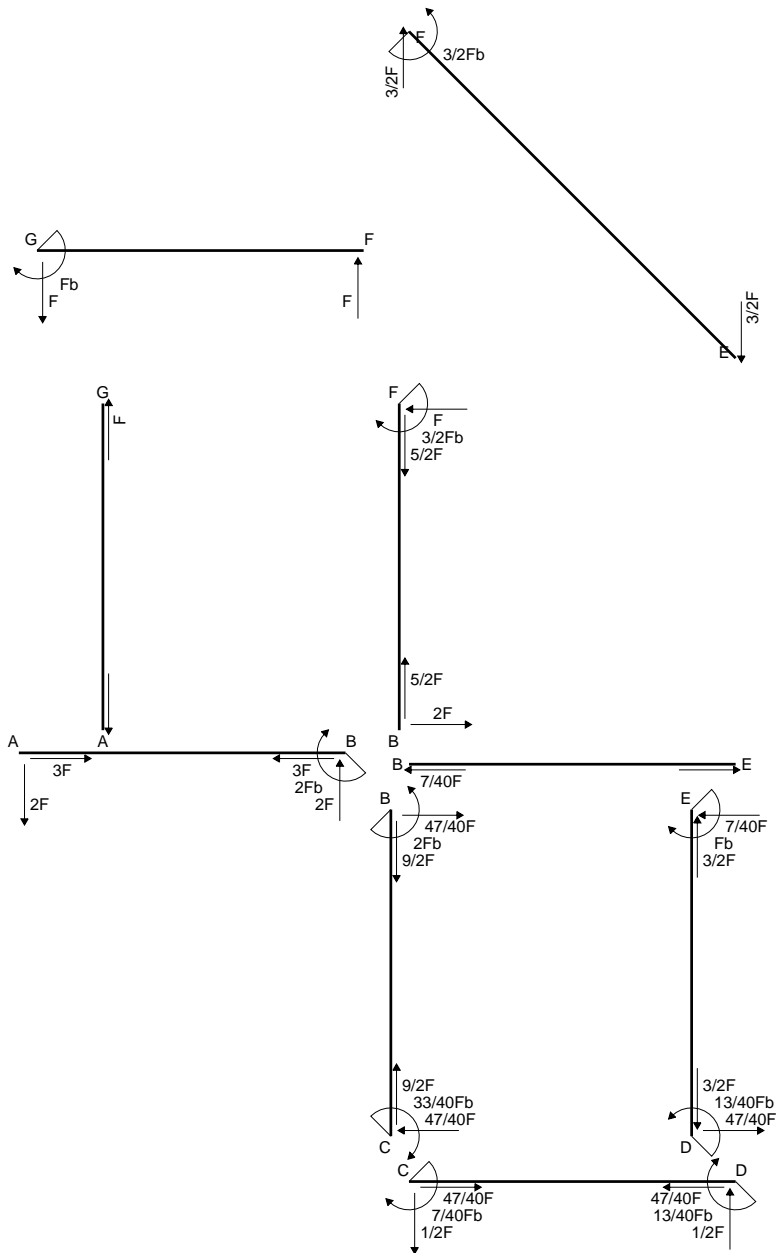

← ⊕ → F

↑ ⊕ ↓ F

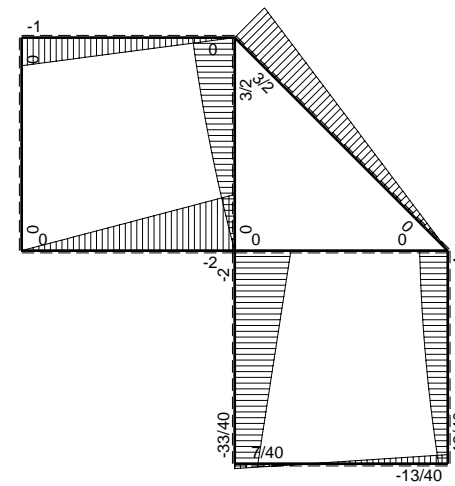

⊕ ⊖ Fb

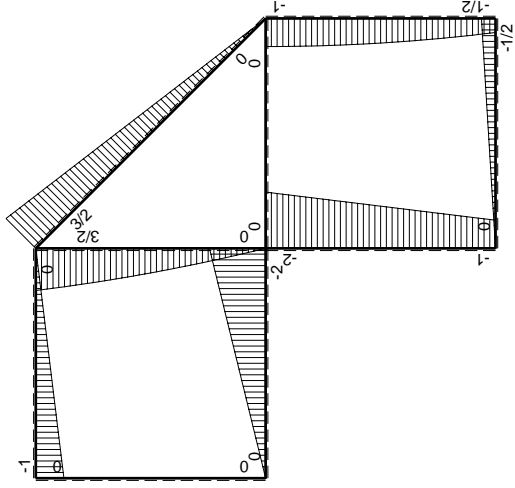
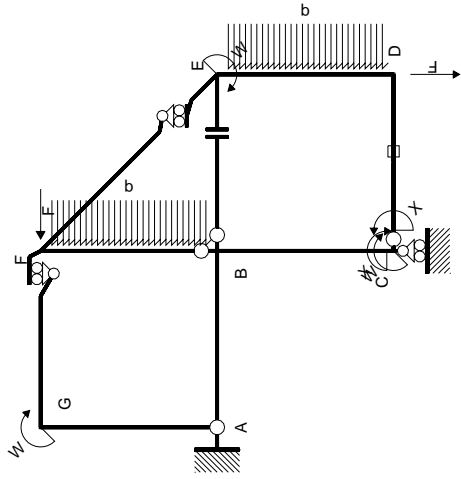

Schema di calcolo iperstatico

M_0 flessione da carichi assegnati

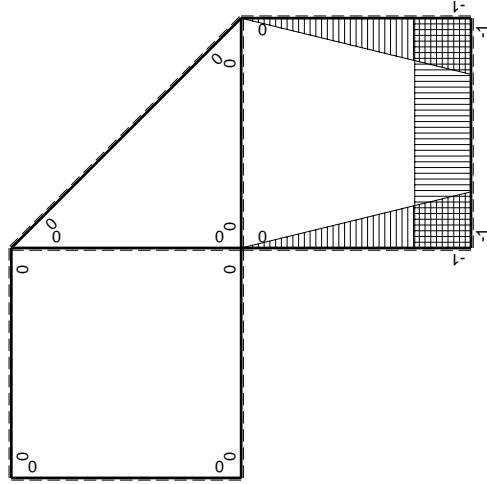

M_x flessione da iperstatica $X=1$

Quadro contributi PLV per iperstatica $X=W_{CD}$

→	$M_x(x)$	$M_o(x)$	$M_x M_o$	$M_x M_x$	$\int M_x M_o / EJ dx$	$\int X M_x M_x / EJ dx$
AB b	0	-2Fx	0	0	0	0
BA b	0	2Fb-2Fx	0	0		
BC b	-x/b	-2Fb+Fx	$2Fx-Fx^2/b$	x^2/b^2	$2/3Fb^2/EJ$	$1/3Xb/EJ$
CB b	1-x/b	Fb+Fx	$Fb-Fx^2/b$	$1-2x/b+x^2/b^2$		
CD b	-1	-1/2Fx	1/2Fx	1	$1/4Fb^2/EJ$	Xb/EJ
DC b	1	1/2Fb-1/2Fx	1/2Fb-1/2Fx	1		
DE b	-1+x/b	$-1/2Fb-Fx+1/2qx^2$	$1/2Fb+1/2Fx-3/2Fx^2/b+1/2qx^3/b$	$1-2x/b+x^2/b^2$	$3/8Fb^2/EJ$	$1/3Xb/EJ$
ED b	x/b	$Fb-1/2qx^2$	$Fx-1/2qx^3/b$	x^2/b^2		
EF $\sqrt{2}b$	0	$3\sqrt{2}/4Fx$	0	0	0	0
FG b	0	-Fx	0	0	0	0
GF b	0	Fb-Fx	0	0		
GA b	0	0	0	0	0	0
AG b	0	0	0	0		
FB b	0	$3/2Fb-Fx-1/2qx^2$	0	0	0	0
BF b	0	$-2Fx+1/2qx^2$	0	0		
BE b	0	0	0	0	0	0
EB b	0	0	0	0		
CD	elongazione asta $N_{iCD} \epsilon_{CD} L_{CD}$				$-Fb^2/EJ$	
	totali				$7/24Fb^2/EJ$	$5/3Xb/EJ$
	iperstatica $X=W_{CD}$				$-7/40Fb$	

Sviluppi di calcolo iperstatica

$$L_{BC}^{xx} = \int_0^b (x^2/b^2) 1/EJ dx = [1/3 x^3/b^2]_0^b 1/EJ$$

$$= (1/3 b) 1/EJ = 1/3 b/EJ$$

$$L_{CB}^{xx} = \int_0^b (1 - 2x/b + x^2/b^2) 1/EJ dx = [x - x^2/b + 1/3 x^3/b^2]_0^b 1/EJ$$

$$= (b - b + 1/3 b) 1/EJ = 1/3 b/EJ$$

$$L_{CD}^{xx} = \int_0^b (1) 1/EJ dx = [x]_0^b 1/EJ$$

$$= (b) 1/EJ = b/EJ$$

$$L_{DC}^{xx} = \int_0^b (1) 1/EJ dx = [x]_0^b 1/EJ$$

$$= (b) 1/EJ = b/EJ$$

$$L_{DE}^{xx} = \int_0^b (1 - 2x/b + x^2/b^2) 1/EJ dx = [x - x^2/b + 1/3 x^3/b^2]_0^b 1/EJ$$

$$= (b - b + 1/3 b) 1/EJ = 1/3 b/EJ$$

$$L_{ED}^{xx} = \int_0^b (x^2/b^2) 1/EJ dx = [1/3 x^3/b^2]_0^b 1/EJ$$

$$= (1/3 b) 1/EJ = 1/3 b/EJ$$

$$L_{BC}^{x_0} = \int_0^b (2x/b - x^2/b^2) Fb 1/EJ dx = [x^2/b - 1/3 x^3/b^2]_0^b Fb 1/EJ$$

$$= (b - 1/3 b) Fb 1/EJ = 2/3 Fb^2/EJ$$

$$L_{CB}^{x_0} = \int_0^b (1 - x^2/b^2) Fb 1/EJ dx = [x - 1/3 x^3/b^2]_0^b Fb 1/EJ$$

$$= (b - 1/3 b) Fb 1/EJ = 2/3 Fb^2/EJ$$

$$L_{CD}^{x_0} = \int_0^b (1/2 x/b) Fb 1/EJ dx + 1 (-1) 1 Fb^2/EJ = [1/4 x^2/b]_0^b Fb 1/EJ + 1 (-1) 1 Fb^2/EJ$$

$$= (1/4 b) Fb 1/EJ + 1 (-1) 1 Fb^2/EJ = -3/4 Fb^2/EJ$$

$$L_{DC}^{x_0} = \int_0^b (1/2 - 1/2 x/b) Fb 1/EJ dx + 1 (-1) 1 Fb^2/EJ = [1/2 x - 1/4 x^2/b]_0^b Fb 1/EJ + 1 (-1) 1 Fb^2/EJ$$

$$= (1/2 b - 1/4 b) Fb 1/EJ + 1 (-1) 1 Fb^2/EJ = -3/4 Fb^2/EJ$$

$$L_{DE}^{x_0} = \int_0^b (1/2 + 1/2 x/b - 3/2 x^2/b^2 + 1/2 x^3/b^3) Fb 1/EJ dx$$

$$= [1/2 x + 1/4 x^2/b - 1/2 x^3/b^2 + 1/8 x^4/b^3]_0^b Fb 1/EJ$$

$$= (1/2 b + 1/4 b - 1/2 b + 1/8 b) Fb 1/EJ = 3/8 Fb^2/EJ$$

$$L_{ED}^{x_0} = \int_0^b (x/b - 1/2 x^3/b^3) Fb 1/EJ dx = [1/2 x^2/b - 1/8 x^4/b^3]_0^b Fb 1/EJ$$

$$= (1/2 b - 1/8 b) Fb 1/EJ = 3/8 Fb^2/EJ$$

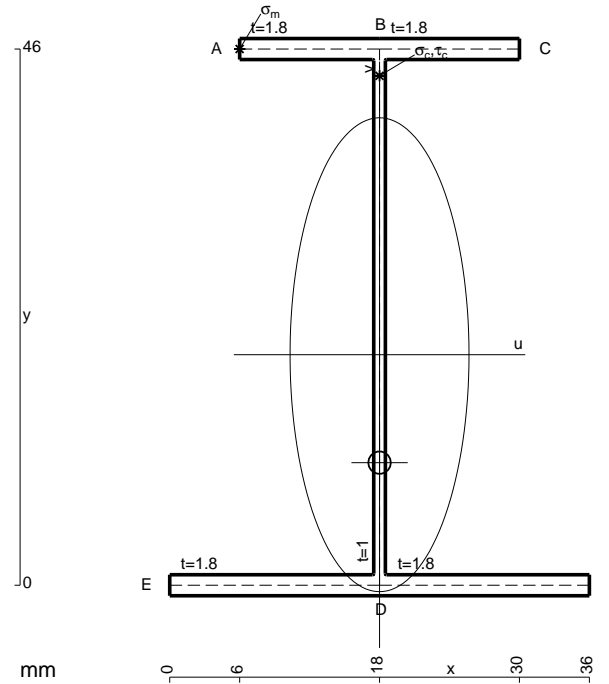

- A = 154. mm²
- J_u = 63641. mm⁴
- J_v = 9072. mm⁴
- J_t = 132. mm⁴
- y_o = -9.26 mm
- y_g = 19.77 mm
- N = -1710. N
- T_y = -1140. N
- M_x = -535800. Nmm
- x_m = 6. mm
- y_m = 46. mm
- u_m = -12. mm
- v_m = 26.23 mm
- σ_m = N/A - Mv/J_u = 209.7 N/mm²
- x_c = 18. mm
- y_c = 46. mm
- v_c = 26.23 mm
- σ_c = N/A - Mv/J_u = 209.7 N/mm²
- τ_c = TS_y/tJ_u = 20.29 N/mm²
- τ_g = TS_y/tJ_u = 20.29 N/mm²
- t_c = 570. mm
- σ_o = √σ² + 3τ² = 212.6 N/mm²

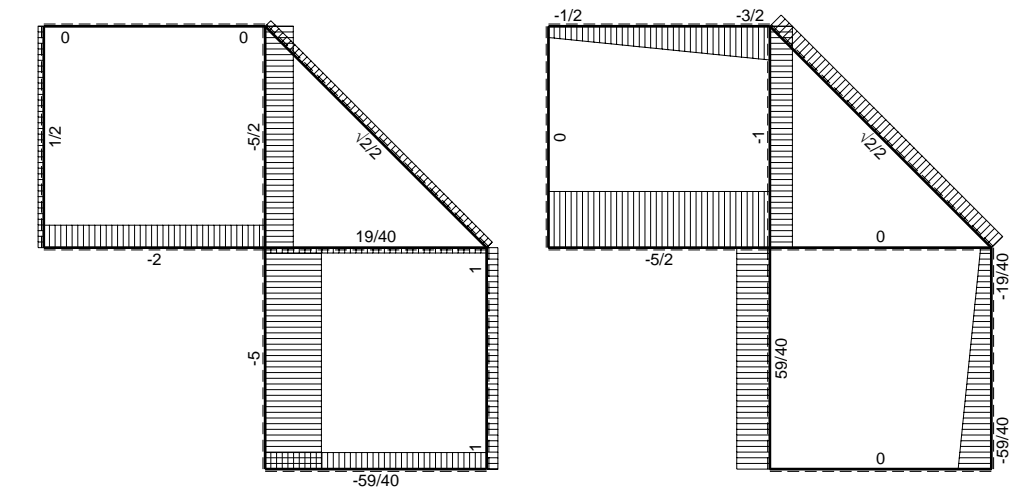
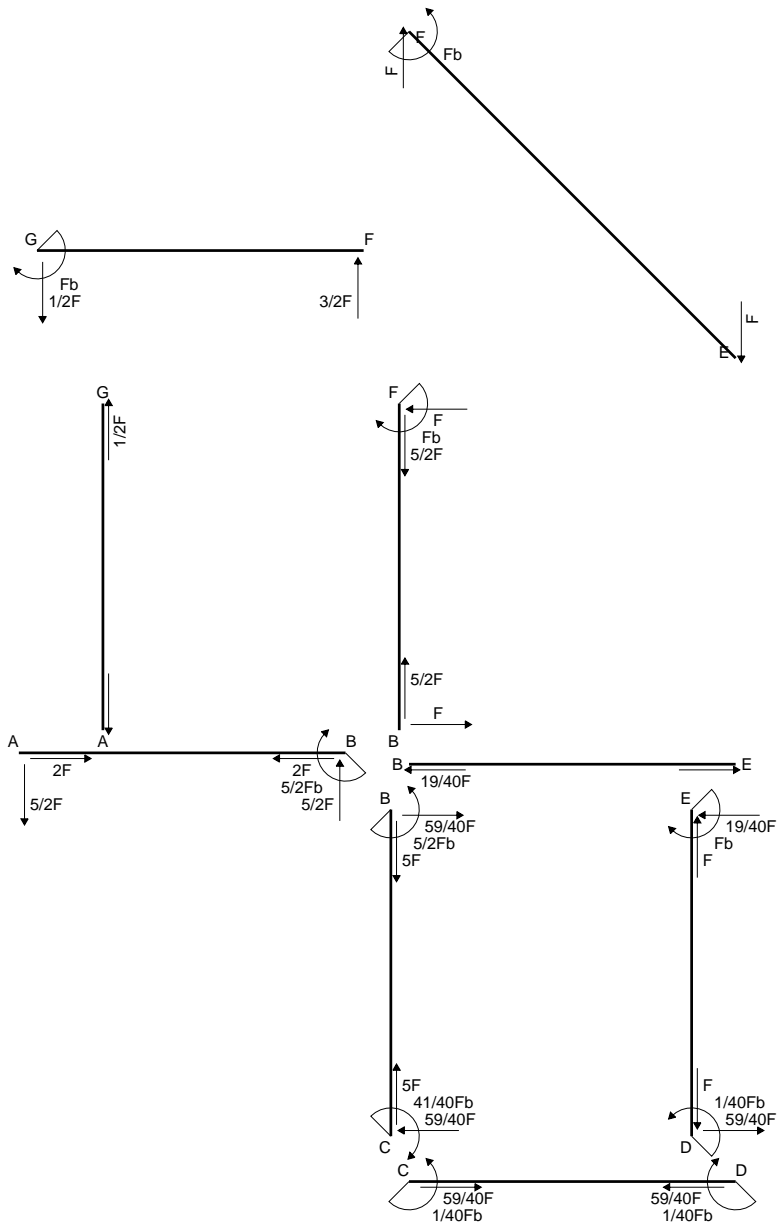

← ⊕ → F

↑ ⊕ ↓ F

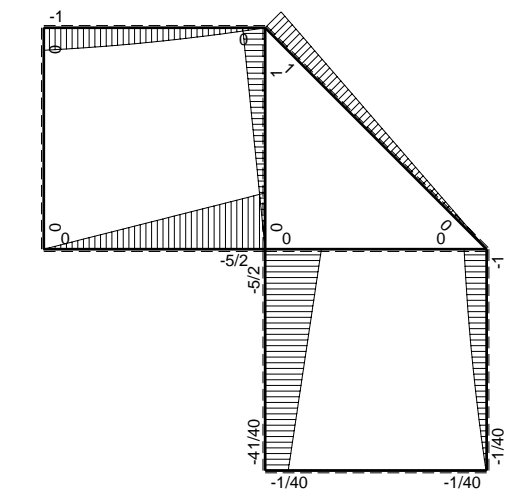

⊕ ⊖ F_b

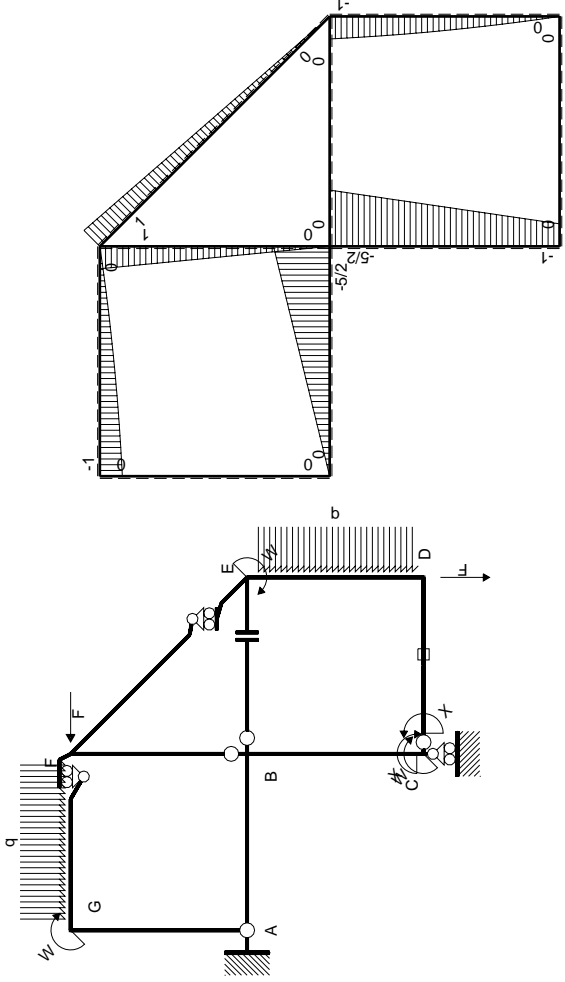

Schema di calcolo iperstatico

M_0 flessione da carichi assegnati

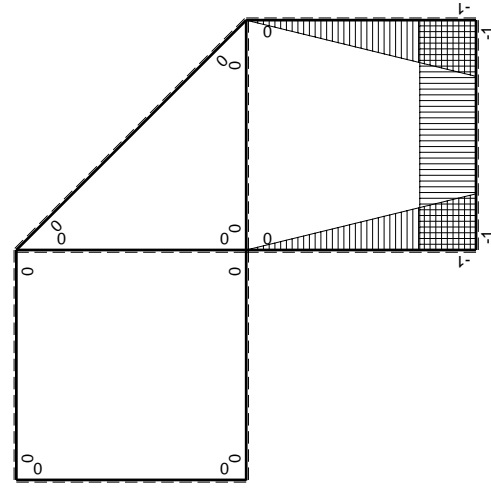

M_x flessione da iperstatica $X=1$

Quadro contributi PLV per iperstatica $X=W_{cd}$

\rightarrow	$M_x(x)$	$M_0(x)$	$M_x M_0$	$M_x M_x$	$\int M_x M_0 / EJ dx$	$\int M_x M_x / EJ dx$
AB b	0	-5/2Fx	0	0	0	0
BA b	0	5/2Fb-5/2Fx	0	0	0	0
BC b	-x/b	-5/2Fb+3/2Fx	5/2Fx-3/2Fx ² /b	x ² /b ²	3/4Fb ² /EJ	1/3Xb/EJ
CB b	1-x/b	Fb+3/2Fx	Fb+1/2Fx-3/2Fx ² /b	1-2x/b+x ² /b ²	0	Xb/EJ
CD b	-1	0	0	1	0	0
DC b	1	0	0	1	0	0
DE b	-1+x/b	-3/2Fx+1/2qx ²	3/2Fx-2Fx ² /b+1/2qx ³ /b	1-2x/b+x ² /b ²	5/24Fb ² /EJ	1/3Xb/EJ
ED b	x/b	Fb-1/2Fx-1/2qx ²	Fx-1/2Fx ² /b-1/2qx ³ /b	x ² /b ²	0	0
EF $\sqrt{2}b$	0	$\sqrt{2}/2Fx$	0	0	0	0
FG b	0	-3/2Fx+1/2qx ²	0	0	0	0
GF b	0	Fb-1/2Fx-1/2qx ²	0	0	0	0
GA b	0	0	0	0	0	0
AG b	0	0	0	0	0	0
FB b	0	Fb-Fx	0	0	0	0
BF b	0	-Fx	0	0	0	0
BE b	0	0	0	0	0	0
EB b	0	0	0	0	0	0
CD	elongazione asta $N_{1,cd} \epsilon_{cd} L_{cd}$				-Fb ² /EJ	
	totali				-1/24Fb ² /EJ	5/3Xb/EJ
	iperstatica $X=W_{cd}$				1/40Fb	

Sviluppi di calcolo iperstatica

$$L_{BC}^{xx} = \int_0^b (x^2/b^2) 1/EJ dx = [1/3 x^3/b^2]_0^b 1/EJ$$

$$= (1/3 b) 1/EJ = 1/3 b/EJ$$

$$L_{CB}^{xx} = \int_0^b (1 - 2x/b + x^2/b^2) 1/EJ dx = [x - x^2/b + 1/3 x^3/b^2]_0^b 1/EJ$$

$$= (b - b + 1/3 b) 1/EJ = 1/3 b/EJ$$

$$L_{CD}^{xx} = \int_0^b (1) 1/EJ dx = [x]_0^b 1/EJ$$

$$= (b) 1/EJ = b/EJ$$

$$L_{DC}^{xx} = \int_0^b (1) 1/EJ dx = [x]_0^b 1/EJ$$

$$= (b) 1/EJ = b/EJ$$

$$L_{DE}^{xx} = \int_0^b (1 - 2x/b + x^2/b^2) 1/EJ dx = [x - x^2/b + 1/3 x^3/b^2]_0^b 1/EJ$$

$$= (b - b + 1/3 b) 1/EJ = 1/3 b/EJ$$

$$L_{ED}^{xx} = \int_0^b (x^2/b^2) 1/EJ dx = [1/3 x^3/b^2]_0^b 1/EJ$$

$$= (1/3 b) 1/EJ = 1/3 b/EJ$$

$$L_{BC}^{xo} = \int_0^b (5/2 x/b - 3/2 x^2/b^2) Fb 1/EJ dx = [5/4 x^2/b - 1/2 x^3/b^2]_0^b Fb 1/EJ$$

$$= (5/4 b - 1/2 b) Fb 1/EJ = 3/4 Fb^2/EJ$$

$$L_{CB}^{xo} = \int_0^b (1 + 1/2 x/b - 3/2 x^2/b^2) Fb 1/EJ dx = [x + 1/4 x^2/b - 1/2 x^3/b^2]_0^b Fb 1/EJ$$

$$= (b + 1/4 b - 1/2 b) Fb 1/EJ = 3/4 Fb^2/EJ$$

$$L_{DE}^{xo} = \int_0^b (3/2 x/b - 2 x^2/b^2 + 1/2 x^3/b^3) Fb 1/EJ dx = [3/4 x^2/b - 2/3 x^3/b^2 + 1/8 x^4/b^3]_0^b Fb 1/EJ$$

$$= (3/4 b - 2/3 b + 1/8 b) Fb 1/EJ = 5/24 Fb^2/EJ$$

$$L_{ED}^{xo} = \int_0^b (x/b - 1/2 x^2/b^2 - 1/2 x^3/b^3) Fb 1/EJ dx = [1/2 x^2/b - 1/6 x^3/b^2 - 1/8 x^4/b^3]_0^b Fb 1/EJ$$

$$= (1/2 b - 1/6 b - 1/8 b) Fb 1/EJ = 5/24 Fb^2/EJ$$

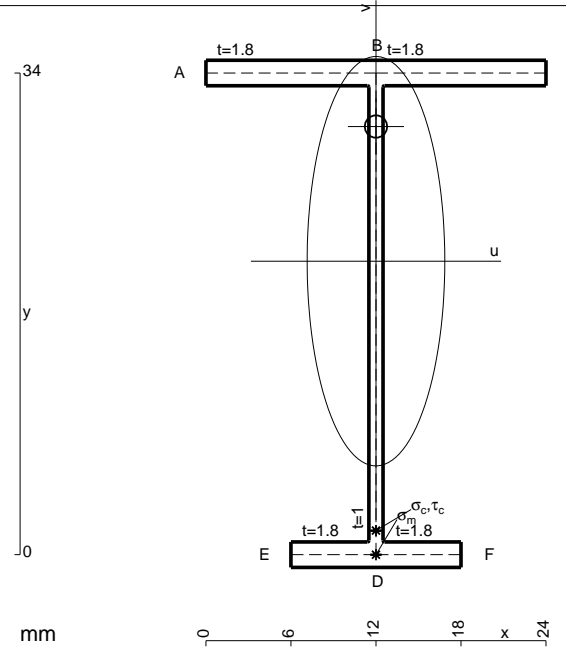

- A = 98.8 mm²
- J_u = 20638. mm⁴
- J_v = 2333. mm⁴
- J_I = 81.32 mm⁴
- y_o = 9.506 mm
- y_g = 20.72 mm
- N = -440. N
- T_y = -550. N
- M_x = -209000. Nmm
- x_m = 12. mm
- v_m = -20.72 mm
- σ_m = N/A - Mv/J_u = -214.3 N/mm²
- y_c = 3. mm
- u_c = -12. mm
- v_c = -17.72 mm
- σ_c = N/A - Mv/J_u = -214.3 N/mm²
- τ_c = TS^{*}/tJ_u = 11.93 N/mm²
- τ_g = TS^{*}/tJ_u = 11.93 N/mm²
- t_c = 220. mm
- σ_o = √σ² + 3τ² = 215.2 N/mm²

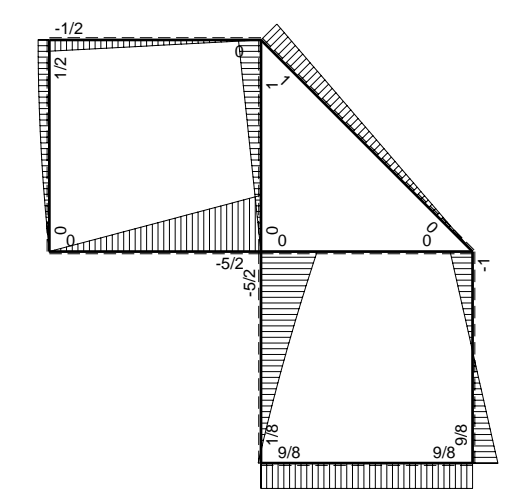
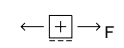
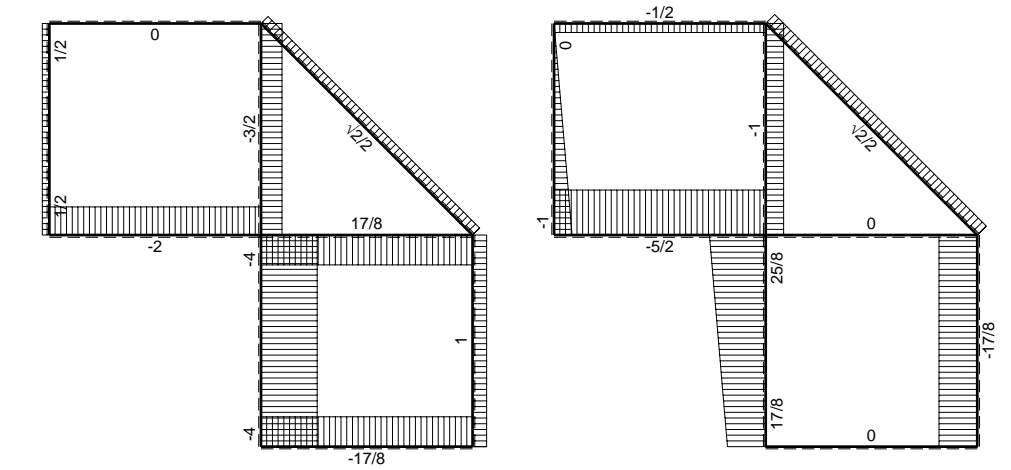
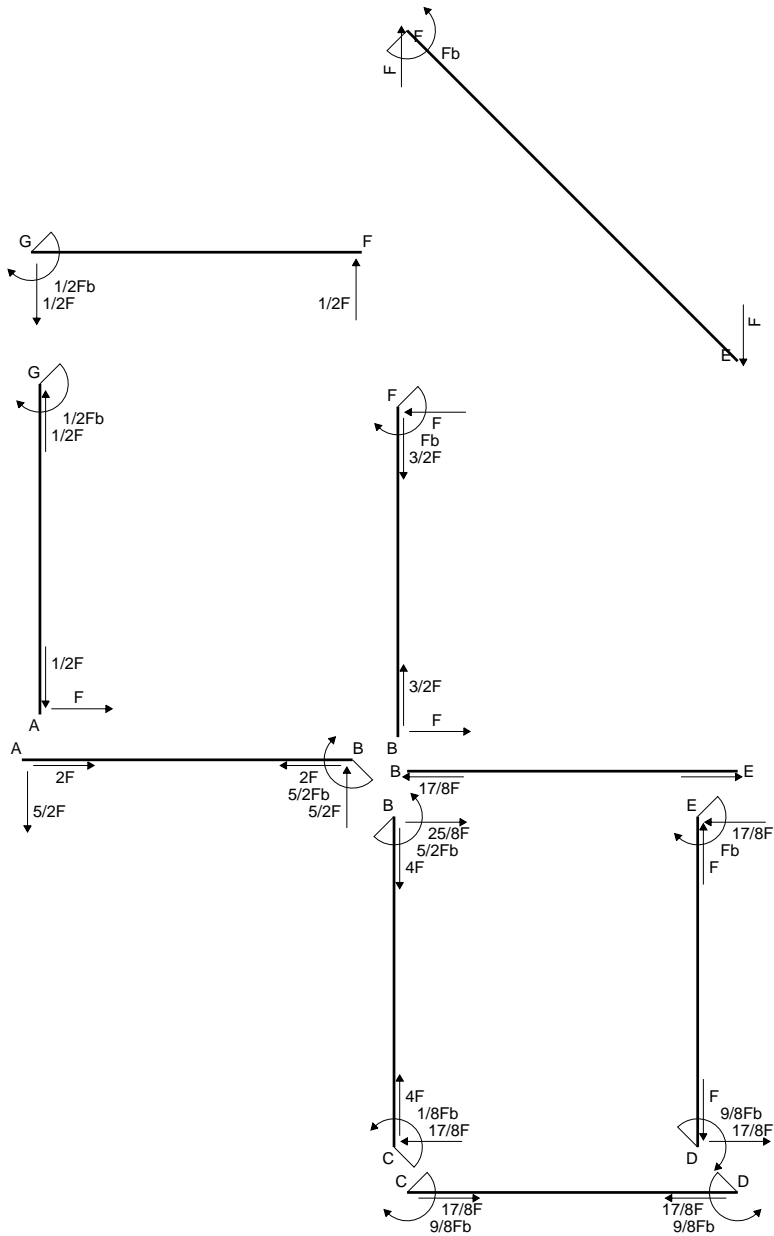

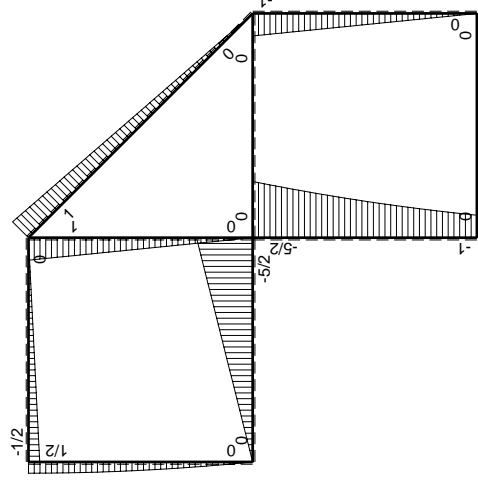
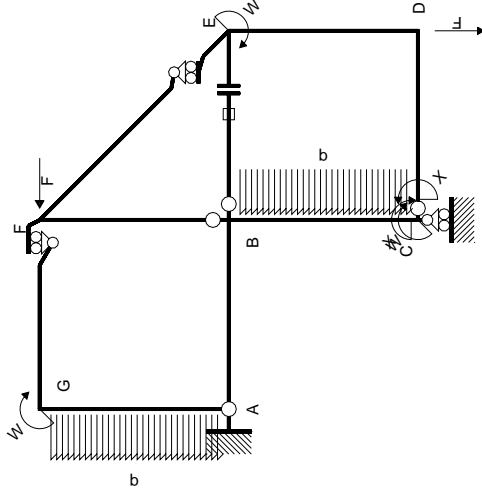

Schema di calcolo iperstatico

$\left(\begin{matrix} + \\ - \end{matrix} \right) M_0$ flessione da carichi assegnati

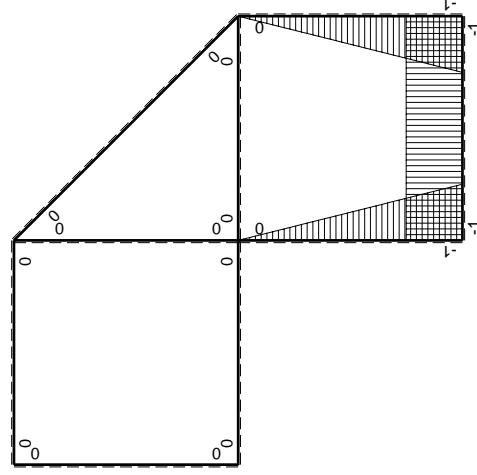

$\left(\begin{matrix} + \\ - \end{matrix} \right) M_x$ flessione da iperstatica $X=1$

Quadro contributi PLV per iperstatica $X=W_{cd}$

\rightarrow	$M_x(x)$	$M_0(x)$	$M_x M_0$	$M_x M_x$	$\int M_x M_0 / E J dx$	$\int M_x M_x / E J dx$
AB b	0	-5/2Fx	0	0	0	0
BA b	0	5/2Fb-5/2Fx	0	0	0	0
BC b	-x/b	-5/2Fb+2Fx-1/2qx ²	5/2Fx-2Fx ² /b+1/2qx ³ /b	x ² /b ²	17/24Fb ² /EJ	1/3Xb/EJ
CB b	1-x/b	Fb+Fx+1/2qx ²	Fb-1/2Fx ² /b-1/2qx ³ /b	1-2x/b+x ² /b ²	0	Xb/EJ
CD b	-1	0	0	1	0	0
DC b	1	0	0	1	0	0
DE b	-1+x/b	-Fx	Fx-Fx ² /b	1-2x/b+x ² /b ²	1/6Fb ² /EJ	1/3Xb/EJ
ED b	x/b	Fb-Fx	Fx-Fx ² /b	x ² /b ²	0	0
EF $\sqrt{2}b$	0	$\sqrt{2}/2Fx$	0	0	0	0
FG b	0	-1/2Fx	0	0	0	0
GF b	0	1/2Fb-1/2Fx	0	0	0	0
GA b	0	1/2Fb-1/2qx ²	0	0	0	0
AG b	0	-Fx+1/2qx ²	0	0	0	0
FB b	0	Fb-Fx	0	0	0	0
BF b	0	-Fx	0	0	0	0
BE b	0	0	0	0	0	0
EB b	0	0	0	0	0	0
BE	elongazione asta $N_{1, BE} \epsilon_{BE} L_{BE}$				Fb ² /EJ	
	totali				15/8Fb ² /EJ	5/3Xb/EJ
	iperstatica $X=W_{cd}$				-9/8Fb	

Sviluppi di calcolo iperstatica

$$L_{BC}^{xx} = \int_0^b (x^2/b^2) 1/EJ dx = [1/3 x^3/b^2]_0^b 1/EJ$$

$$= (1/3 b) 1/EJ = 1/3 b/EJ$$

$$L_{CB}^{xx} = \int_0^b (1 - 2x/b + x^2/b^2) 1/EJ dx = [x - x^2/b + 1/3 x^3/b^2]_0^b 1/EJ$$

$$= (b - b + 1/3 b) 1/EJ = 1/3 b/EJ$$

$$L_{CD}^{xx} = \int_0^b (1) 1/EJ dx = [x]_0^b 1/EJ$$

$$= (b) 1/EJ = b/EJ$$

$$L_{DC}^{xx} = \int_0^b (1) 1/EJ dx = [x]_0^b 1/EJ$$

$$= (b) 1/EJ = b/EJ$$

$$L_{DE}^{xx} = \int_0^b (1 - 2x/b + x^2/b^2) 1/EJ dx = [x - x^2/b + 1/3 x^3/b^2]_0^b 1/EJ$$

$$= (b - b + 1/3 b) 1/EJ = 1/3 b/EJ$$

$$L_{ED}^{xx} = \int_0^b (x^2/b^2) 1/EJ dx = [1/3 x^3/b^2]_0^b 1/EJ$$

$$= (1/3 b) 1/EJ = 1/3 b/EJ$$

$$L_{BC}^{xo} = \int_0^b (5/2 x/b - 2x^2/b^2 + 1/2 x^3/b^3) Fb 1/EJ dx = [5/4 x^2/b - 2/3 x^3/b^2 + 1/8 x^4/b^3]_0^b Fb 1/EJ$$

$$= (5/4 b - 2/3 b + 1/8 b) Fb 1/EJ = 17/24 Fb^2/EJ$$

$$L_{CB}^{xo} = \int_0^b (1 - 1/2 x^2/b^2 - 1/2 x^3/b^3) Fb 1/EJ dx = [x - 1/6 x^3/b^2 - 1/8 x^4/b^3]_0^b Fb 1/EJ$$

$$= (b - 1/6 b - 1/8 b) Fb 1/EJ = 17/24 Fb^2/EJ$$

$$L_{DE}^{xo} = \int_0^b (x/b - x^2/b^2) Fb 1/EJ dx = [1/2 x^2/b - 1/3 x^3/b^2]_0^b Fb 1/EJ$$

$$= (1/2 b - 1/3 b) Fb 1/EJ = 1/6 Fb^2/EJ$$

$$L_{ED}^{xo} = \int_0^b (x/b - x^2/b^2) Fb 1/EJ dx = [1/2 x^2/b - 1/3 x^3/b^2]_0^b Fb 1/EJ$$

$$= (1/2 b - 1/3 b) Fb 1/EJ = 1/6 Fb^2/EJ$$

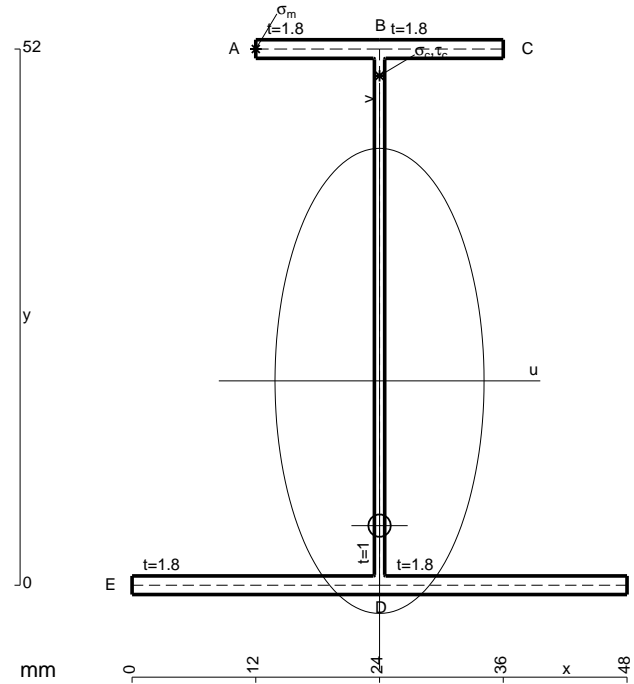

- A = 181.6 mm²
- J_u = 92380. mm⁴
- J_v = 18662. mm⁴
- J_t = 157.3 mm⁴
- y_o = -14.04 mm
- y_g = 19.82 mm
- N = -840. N
- T_y = -1050. N
- M_x = -661500. Nmm
- x_m = 12. mm
- y_m = 52. mm
- u_m = -12. mm
- v_m = 32.19 mm
- σ_m = N/A - M_v/J_u = 225.8 N/mm²
- x_c = 24. mm
- y_c = 52. mm
- v_c = 32.19 mm
- σ_c = N/A - M_v/J_u = 225.8 N/mm²
- τ_c = T_S/t_J_u = 15.8 N/mm²
- τ_g = T_S/t_J_u = 15.8 N/mm²
- t_c = 420. mm
- σ_o = √σ² + 3τ² = 227.5 N/mm²

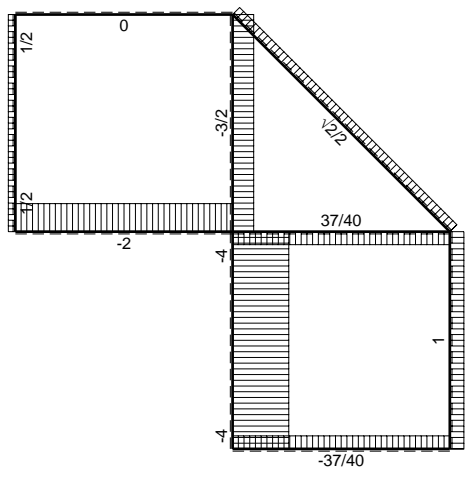
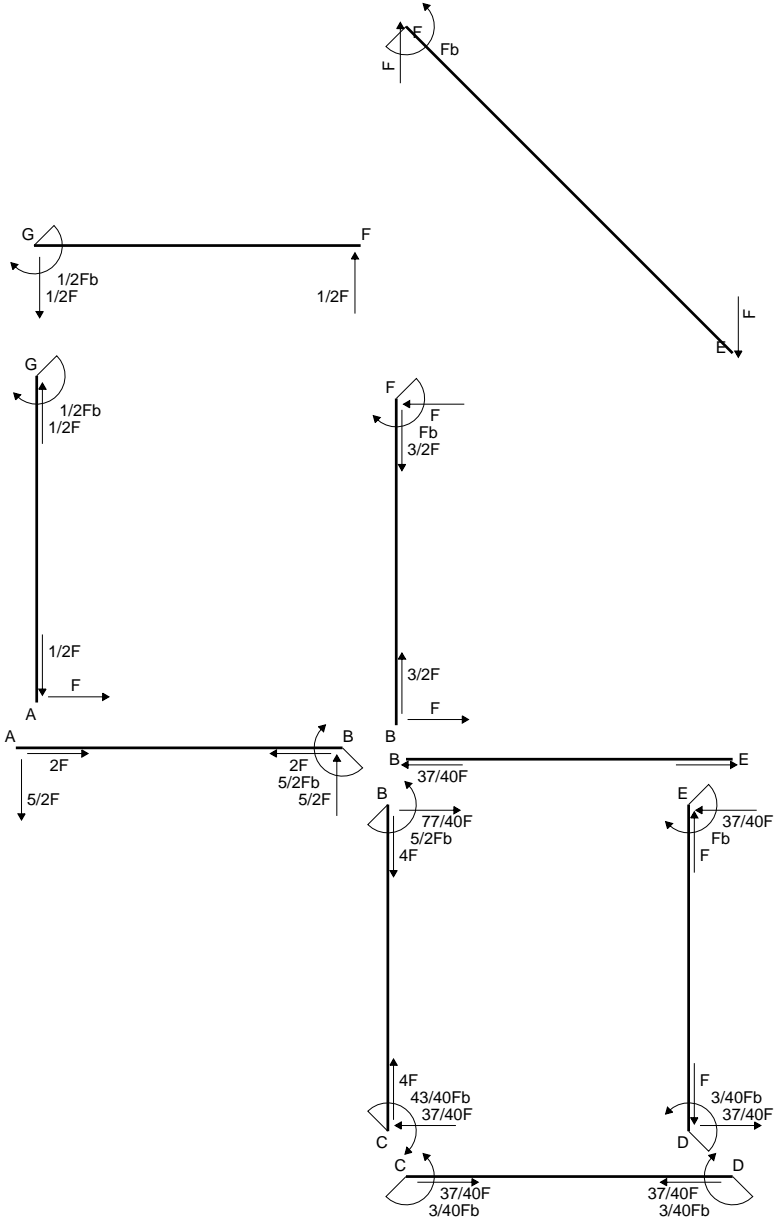

← ⊕ → F

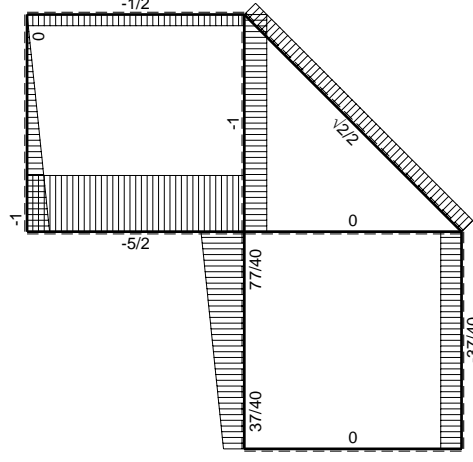

↑ ⊕ ↓ F

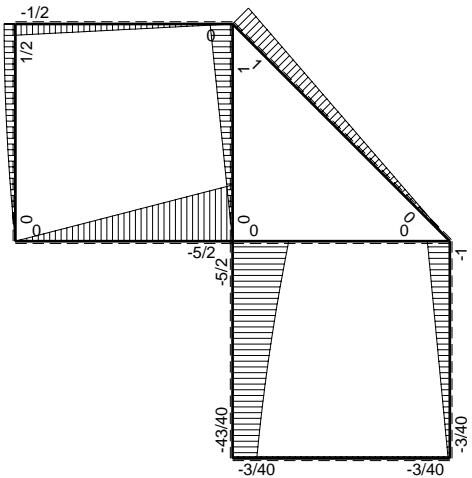

⊕ ⊖ F_b

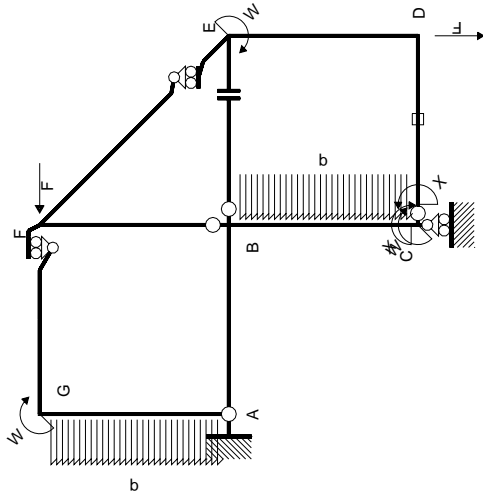

Schema di calcolo iperstatico

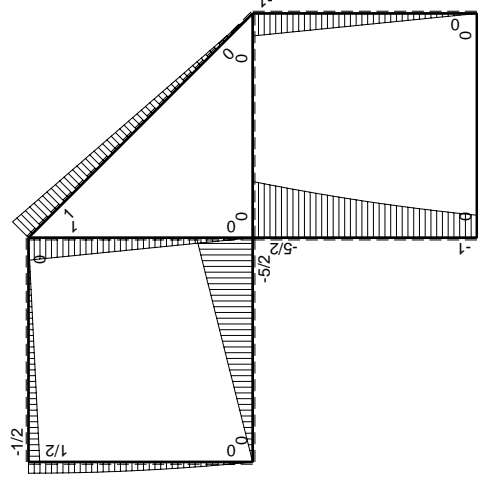

M_0 flessione da carichi assegnati

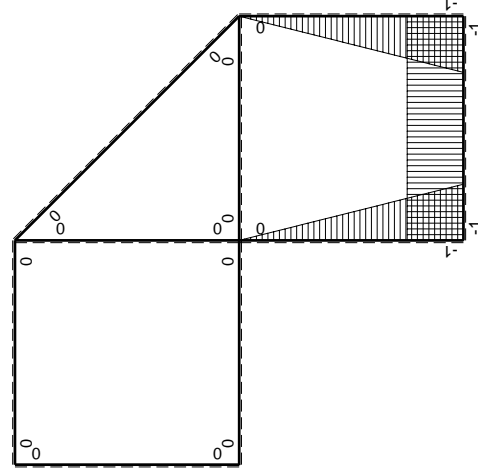

M_x flessione da iperstatica $X=1$

Quadro contributi PLV per iperstatica $X=W_{cd}$

\rightarrow	$M_x(x)$	$M_0(x)$	$M_x M_0$	$M_x M_x$	$\int M_x M_0 / E J dx$	$\int M_x M_x / E J dx$
AB b	0	-5/2Fx	0	0	0	0
BA b	0	5/2Fb-5/2Fx	0	0	0	0
BC b	-x/b	-5/2Fb+2Fx-1/2qx ²	5/2Fx-2Fx ² /b+1/2qx ³ /b	x ² /b ²	17/24Fb ² /EJ	1/3Xb/EJ
CB b	1-x/b	Fb+Fx+1/2qx ²	Fb-1/2Fx ² /b-1/2qx ³ /b	1-2x/b+x ² /b ²	0	Xb/EJ
CD b	-1	0	0	1	0	0
DC b	1	0	0	1	0	0
DE b	-1+x/b	-Fx	Fx-Fx ² /b	1-2x/b+x ² /b ²	1/6Fb ² /EJ	1/3Xb/EJ
ED b	x/b	Fb-Fx	Fx-Fx ² /b	x ² /b ²	0	0
EF $\sqrt{2}b$	0	$\sqrt{2}/2Fx$	0	0	0	0
FG b	0	-1/2Fx	0	0	0	0
GF b	0	1/2Fb-1/2Fx	0	0	0	0
GA b	0	1/2Fb-1/2qx ²	0	0	0	0
AG b	0	-Fx+1/2qx ²	0	0	0	0
FB b	0	Fb-Fx	0	0	0	0
BF b	0	-Fx	0	0	0	0
BE b	0	0	0	0	0	0
EB b	0	0	0	0	0	0
CD	elongazione asta $N_{1,cd} \epsilon_{cd} l_{cd}$				-Fb ² /EJ	
	totali				-1/8Fb ² /EJ	5/3Xb/EJ
	iperstatica $X=W_{cd}$				3/40Fb	

Sviluppi di calcolo iperstatica

$$L_{BC}^{xx} = \int_0^b (x^2/b^2) 1/EJ dx = [1/3 x^3/b^2]_0^b 1/EJ$$

$$= (1/3 b) 1/EJ = 1/3 b/EJ$$

$$L_{CB}^{xx} = \int_0^b (1 - 2x/b + x^2/b^2) 1/EJ dx = [x - x^2/b + 1/3 x^3/b^2]_0^b 1/EJ$$

$$= (b - b + 1/3 b) 1/EJ = 1/3 b/EJ$$

$$L_{CD}^{xx} = \int_0^b (1) 1/EJ dx = [x]_0^b 1/EJ$$

$$= (b) 1/EJ = b/EJ$$

$$L_{DC}^{xx} = \int_0^b (1) 1/EJ dx = [x]_0^b 1/EJ$$

$$= (b) 1/EJ = b/EJ$$

$$L_{DE}^{xx} = \int_0^b (1 - 2x/b + x^2/b^2) 1/EJ dx = [x - x^2/b + 1/3 x^3/b^2]_0^b 1/EJ$$

$$= (b - b + 1/3 b) 1/EJ = 1/3 b/EJ$$

$$L_{ED}^{xx} = \int_0^b (x^2/b^2) 1/EJ dx = [1/3 x^3/b^2]_0^b 1/EJ$$

$$= (1/3 b) 1/EJ = 1/3 b/EJ$$

$$L_{BC}^{xo} = \int_0^b (5/2 x/b - 2x^2/b^2 + 1/2 x^3/b^3) Fb 1/EJ dx = [5/4 x^2/b - 2/3 x^3/b^2 + 1/8 x^4/b^3]_0^b Fb 1/EJ$$

$$= (5/4 b - 2/3 b + 1/8 b) Fb 1/EJ = 17/24 Fb^2/EJ$$

$$L_{CB}^{xo} = \int_0^b (1 - 1/2 x^2/b^2 - 1/2 x^3/b^3) Fb 1/EJ dx = [x - 1/6 x^3/b^2 - 1/8 x^4/b^3]_0^b Fb 1/EJ$$

$$= (b - 1/6 b - 1/8 b) Fb 1/EJ = 17/24 Fb^2/EJ$$

$$L_{DE}^{xo} = \int_0^b (x/b - x^2/b^2) Fb 1/EJ dx = [1/2 x^2/b - 1/3 x^3/b^2]_0^b Fb 1/EJ$$

$$= (1/2 b - 1/3 b) Fb 1/EJ = 1/6 Fb^2/EJ$$

$$L_{ED}^{xo} = \int_0^b (x/b - x^2/b^2) Fb 1/EJ dx = [1/2 x^2/b - 1/3 x^3/b^2]_0^b Fb 1/EJ$$

$$= (1/2 b - 1/3 b) Fb 1/EJ = 1/6 Fb^2/EJ$$

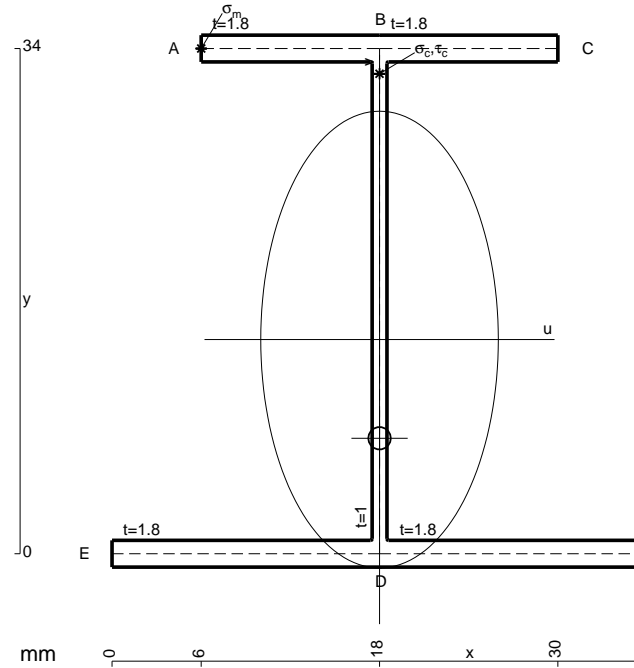

- A = 142. mm²
- J_u = 33538. mm⁴
- J_v = 9072. mm⁴
- J_t = 128. mm⁴
- y_o = -6.643 mm
- y_g = 14.41 mm
- N = -760. N
- T_y = -950. N
- M_x = -418000. Nmm
- x_m = 6. mm
- y_m = 34. mm
- u_m = -12. mm
- v_m = 19.59 mm
- σ_m = N/A-Mv/J_u = 238.8 N/mm²
- x_c = 18. mm
- y_c = 34. mm
- v_c = 19.59 mm
- σ_c = N/A-Mv/J_u = 238.8 N/mm²
- τ_c = TS/tJ_u = 23.97 N/mm²
- τ_g = TS/tJ_u = 23.97 N/mm²
- t_c = 380. mm
- σ_o = √σ²+3τ² = 242.3 N/mm²

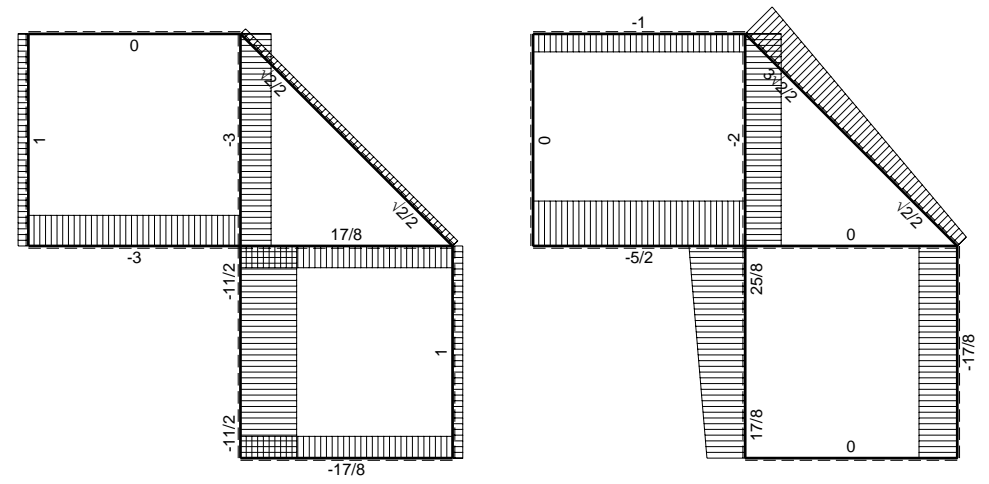
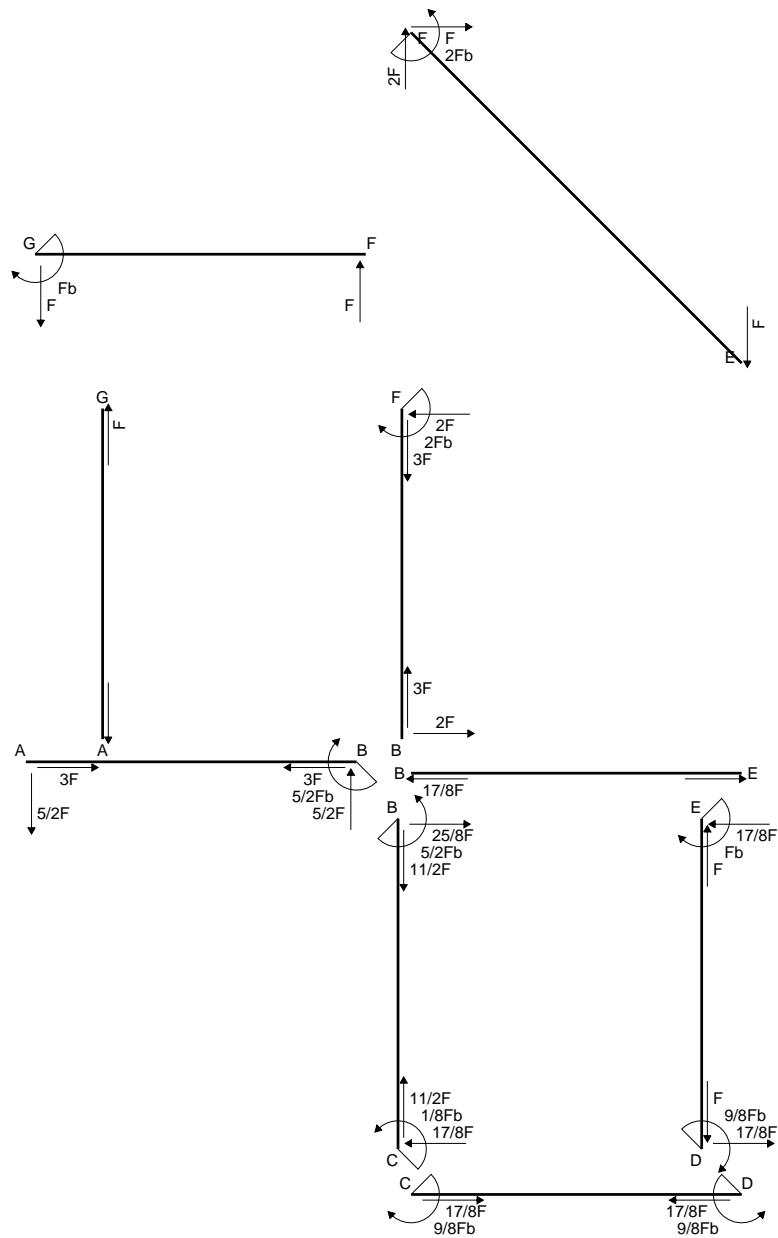

← ⊕ → F

↑ ⊕ ↓ F

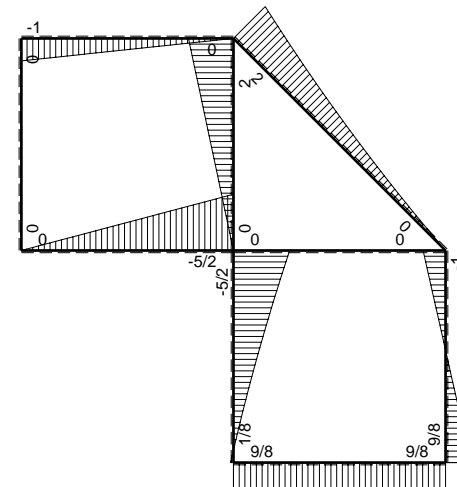

⊕ ⊖ Fb

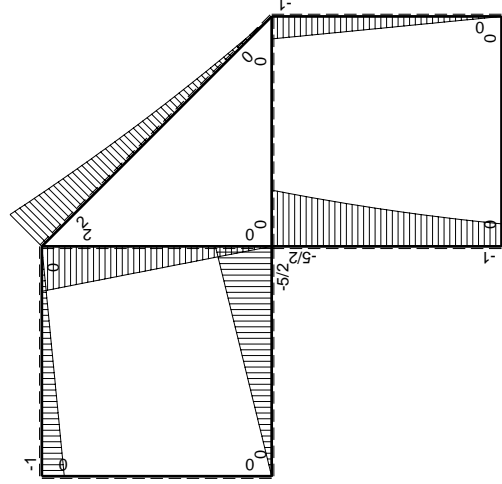
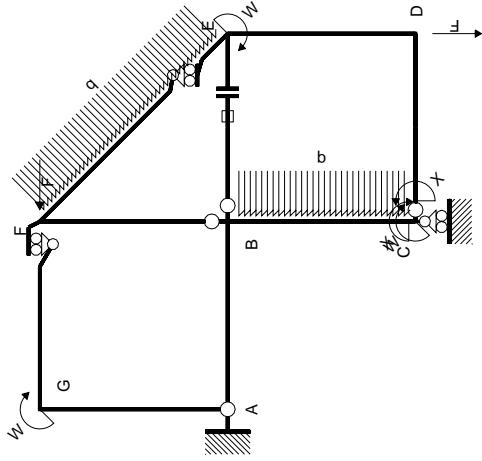

Schema di calcolo iperstatico

M_0 flessione da carichi assegnati

Quadro contribuiti PLV per iperstatica $X=W_{cd}$

\rightarrow	$M_x(x)$	$M_0(x)$	$M_x M_0$	$M_x M_x$	$\int M_x M_0 / E J dx$	$\int M_x M_x / E J dx$
AB b	0	-5/2Fx	0	0	0	0
BA b	0	5/2Fb-5/2Fx	0	0	0	0
BC b	-x/b	-5/2Fb+2Fx-1/2qx ²	5/2Fx-2Fx ² /b+1/2qx ³ /b	x ² /b ²	17/24Fb ² /EJ	1/3Xb/EJ
CB b	1-x/b	Fb+Fx+1/2qx ²	Fb-1/2Fx ² /b-1/2qx ³ /b	1-2x/b+x ² /b ²	0	Xb/EJ
CD b	-1	0	0	1	0	0
DC b	1	0	0	1	0	0
DE b	-1+x/b	-Fx	Fx-Fx ² /b	1-2x/b+x ² /b ²	1/6Fb ² /EJ	1/3Xb/EJ
ED b	x/b	Fb-Fx	Fx-Fx ² /b	x ² /b ²	0	0
EF $\sqrt{2}b$	0	$\sqrt{2}/2Fx+1/2qx2$	0	0	0	0
FG b	0	-Fx	0	0	0	0
GF b	0	Fb-Fx	0	0	0	0
GA b	0	0	0	0	0	0
AG b	0	0	0	0	0	0
FB b	0	2Fb-2Fx	0	0	0	0
BF b	0	-2Fx	0	0	0	0
BE b	0	0	0	0	0	0
EB b	0	0	0	0	0	0
BE	elongazione asta $N_{1, BE} \epsilon_{BE} L_{BE}$				Fb ² /EJ	
	totali				15/8Fb ² /EJ	5/3Xb/EJ
	iperstatica $X=W_{cd}$				-9/8Fb	

Sviluppi di calcolo iperstatica

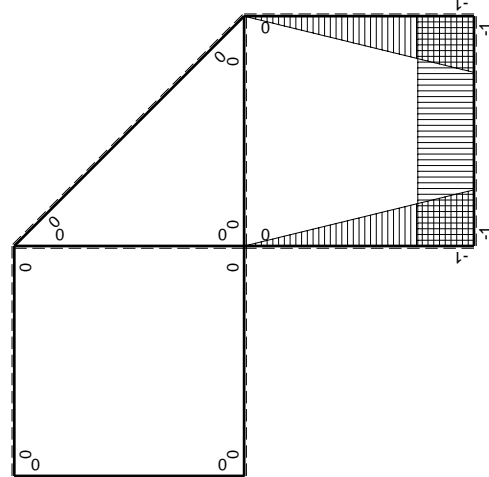

M_x flessione da iperstatica $X=1$

$$L_{BC}^{xx} = \int_0^b (x^2/b^2) 1/EJ dx = [1/3 x^3/b^2]_0^b 1/EJ$$

$$= (1/3 b) 1/EJ = 1/3 b/EJ$$

$$L_{CB}^{xx} = \int_0^b (1 - 2x/b + x^2/b^2) 1/EJ dx = [x - x^2/b + 1/3 x^3/b^2]_0^b 1/EJ$$

$$= (b - b + 1/3 b) 1/EJ = 1/3 b/EJ$$

$$L_{CD}^{xx} = \int_0^b (1) 1/EJ dx = [x]_0^b 1/EJ$$

$$= (b) 1/EJ = b/EJ$$

$$L_{DC}^{xx} = \int_0^b (1) 1/EJ dx = [x]_0^b 1/EJ$$

$$= (b) 1/EJ = b/EJ$$

$$L_{DE}^{xx} = \int_0^b (1 - 2x/b + x^2/b^2) 1/EJ dx = [x - x^2/b + 1/3 x^3/b^2]_0^b 1/EJ$$

$$= (b - b + 1/3 b) 1/EJ = 1/3 b/EJ$$

$$L_{ED}^{xx} = \int_0^b (x^2/b^2) 1/EJ dx = [1/3 x^3/b^2]_0^b 1/EJ$$

$$= (1/3 b) 1/EJ = 1/3 b/EJ$$

$$L_{BC}^{x_0} = \int_0^b (5/2 x/b - 2x^2/b^2 + 1/2 x^3/b^3) Fb 1/EJ dx = [5/4 x^2/b - 2/3 x^3/b^2 + 1/8 x^4/b^3]_0^b Fb 1/EJ$$

$$= (5/4 b - 2/3 b + 1/8 b) Fb 1/EJ = 17/24 Fb^2/EJ$$

$$L_{CB}^{x_0} = \int_0^b (1 - 1/2 x^2/b^2 - 1/2 x^3/b^3) Fb 1/EJ dx = [x - 1/6 x^3/b^2 - 1/8 x^4/b^3]_0^b Fb 1/EJ$$

$$= (b - 1/6 b - 1/8 b) Fb 1/EJ = 17/24 Fb^2/EJ$$

$$L_{DE}^{x_0} = \int_0^b (x/b - x^2/b^2) Fb 1/EJ dx = [1/2 x^2/b - 1/3 x^3/b^2]_0^b Fb 1/EJ$$

$$= (1/2 b - 1/3 b) Fb 1/EJ = 1/6 Fb^2/EJ$$

$$L_{ED}^{x_0} = \int_0^b (x/b - x^2/b^2) Fb 1/EJ dx = [1/2 x^2/b - 1/3 x^3/b^2]_0^b Fb 1/EJ$$

$$= (1/2 b - 1/3 b) Fb 1/EJ = 1/6 Fb^2/EJ$$

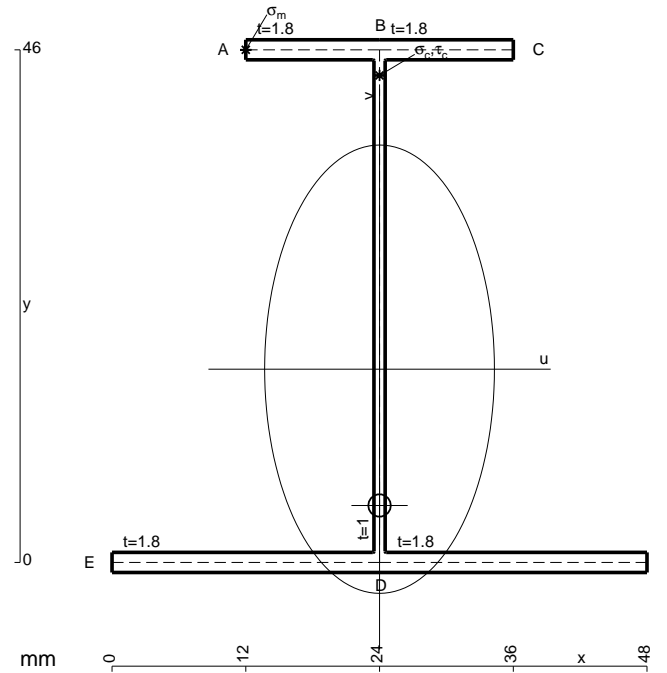

- A = 175.6 mm²
- J_u = 71048. mm⁴
- J_v = 18662. mm⁴
- J_t = 155.3 mm⁴
- y_o = -12.23 mm
- y_g = 17.34 mm
- N = -930. N
- T_y = -775. N
- M_x = -496000. Nmm
- x_m = 12. mm
- y_m = 46. mm
- u_m = -12. mm
- v_m = 28.66 mm
- σ_m = N/A - M_v/J_u = 194.8 N/mm²
- x_c = 24. mm
- y_c = 46. mm
- v_c = 28.66 mm
- σ_c = N/A - M_v/J_u = 194.8 N/mm²
- τ_c = T_S/t_{J_u} = 13.5 N/mm²
- τ_g = T_S/t_{J_u} = 13.5 N/mm²
- t_c = 310. mm
- σ_o = √(σ² + 3τ²) = 196.2 N/mm²

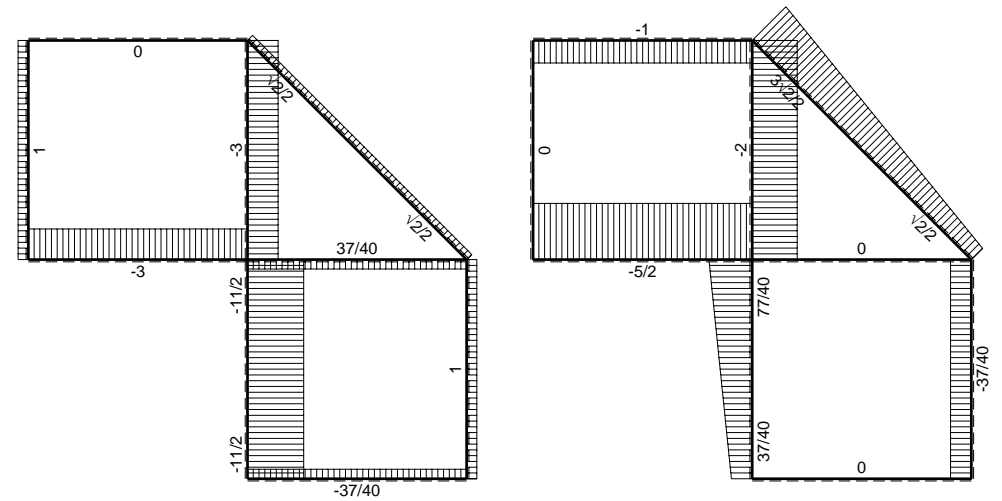
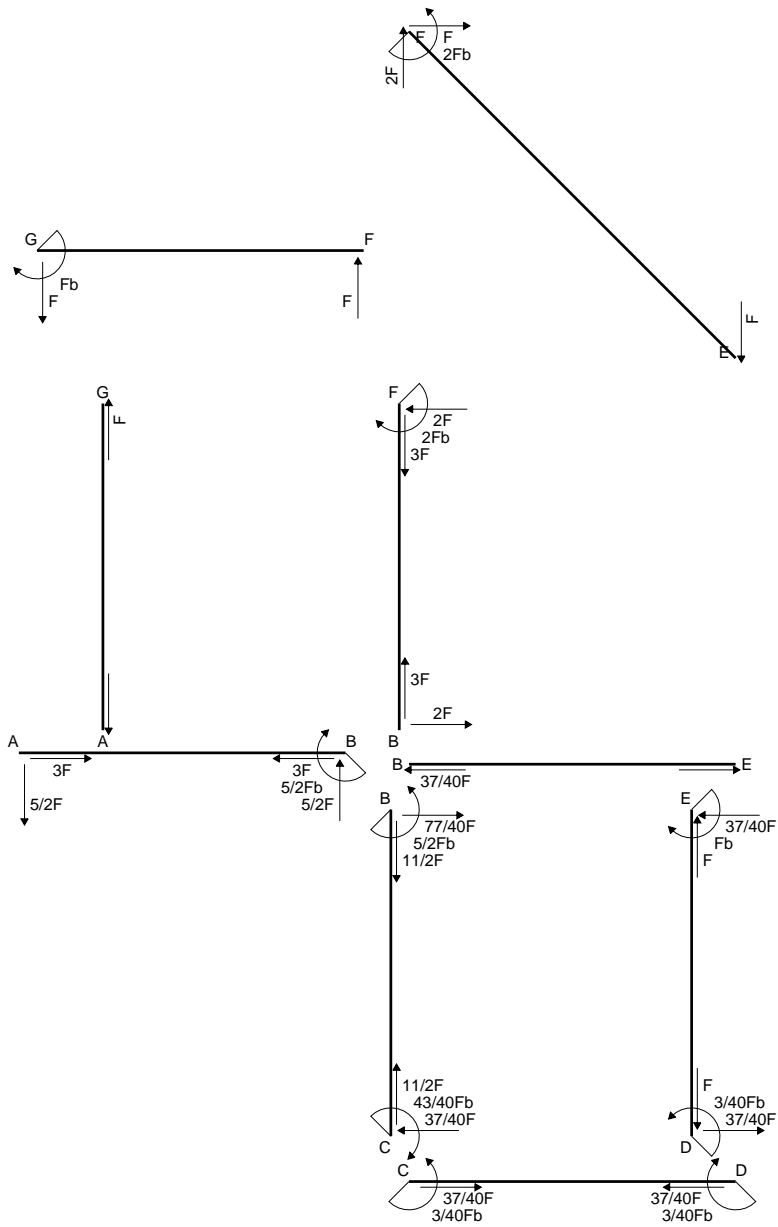

← ⊕ → F

↑ ⊕ ↓ F

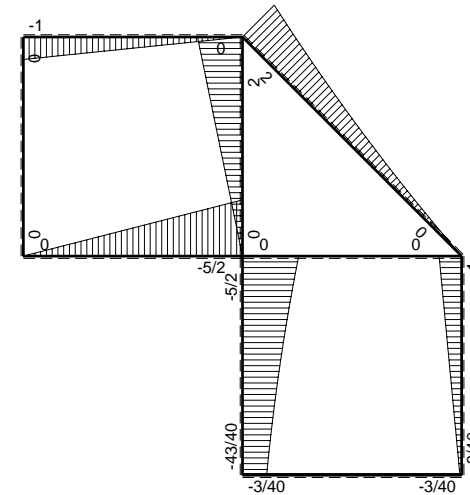

⊕ F_b

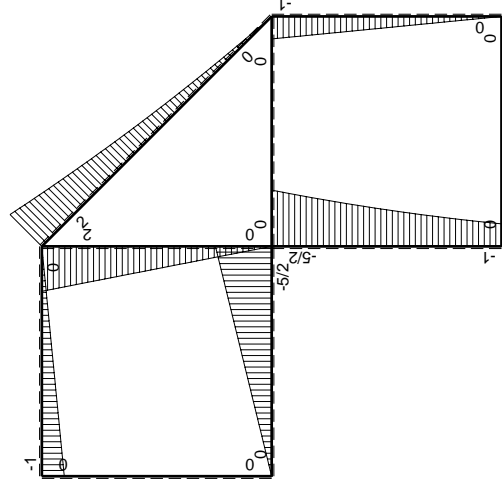
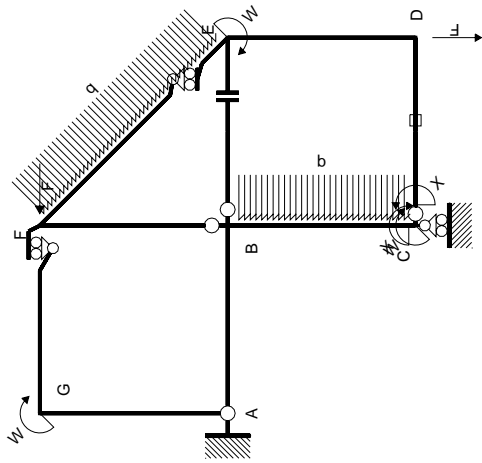

Schema di calcolo iperstatico

M_0 flessione da carichi assegnati

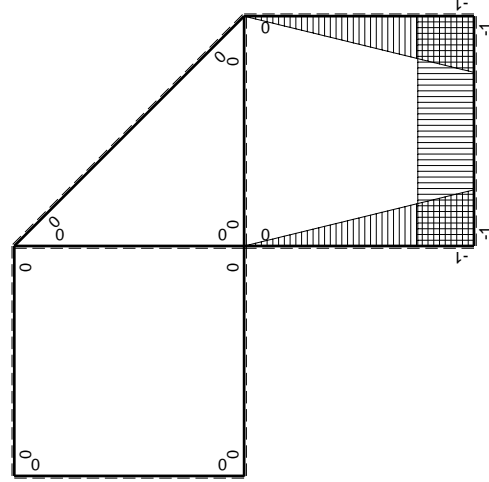

M_x flessione da iperstatica $X=1$

Quadro contribuiti PLV per iperstatica $X=W_{cd}$

\rightarrow	$M_x(x)$	$M_0(x)$	$M_x M_0$	$M_x M_x$	$\int M_x M_0 / E J dx$	$\int M_x M_x / E J dx$
AB b	0	-5/2Fx	0	0	0	0
BA b	0	5/2Fb-5/2Fx	0	0	0	0
BC b	-x/b	-5/2Fb+2Fx-1/2qx ²	5/2Fx-2Fx ² /b+1/2qx ³ /b	x ² /b ²	17/24Fb ² /EJ	1/3Xb/EJ
CB b	1-x/b	Fb+Fx+1/2qx ²	Fb-1/2Fx ² /b-1/2qx ³ /b	1-2x/b+x ² /b ²		Xb/EJ
CD b	-1	0	0	1	0	0
DC b	1	0	0	1	0	0
DE b	-1+x/b	-Fx	Fx-Fx ² /b	1-2x/b+x ² /b ²	1/6Fb ² /EJ	1/3Xb/EJ
ED b	x/b	Fb-Fx	Fx-Fx ² /b	x ² /b ²		0
EF $\sqrt{2}b$	0	$\sqrt{2}/2Fx+1/2qx2$	0	0	0	0
FG b	0	-Fx	0	0	0	0
GF b	0	Fb-Fx	0	0	0	0
GA b	0	0	0	0	0	0
AG b	0	0	0	0	0	0
FB b	0	2Fb-2Fx	0	0	0	0
BF b	0	-2Fx	0	0	0	0
BE b	0	0	0	0	0	0
EB b	0	0	0	0	0	0
CD	elongazione asta $N_{1,cd} \epsilon_{cd} L_{cd}$				-Fb ² /EJ	
	totali				-1/8Fb ² /EJ	5/3Xb/EJ
	iperstatica $X=W_{cd}$				3/40Fb	

Sviluppi di calcolo iperstatica

$$L_{BC}^{xx} = \int_0^b (x^2/b^2) 1/EJ dx = [1/3 x^3/b^2]_0^b 1/EJ$$

$$= (1/3 b) 1/EJ = 1/3 b/EJ$$

$$L_{CB}^{xx} = \int_0^b (1 - 2x/b + x^2/b^2) 1/EJ dx = [x - x^2/b + 1/3 x^3/b^2]_0^b 1/EJ$$

$$= (b - b + 1/3 b) 1/EJ = 1/3 b/EJ$$

$$L_{CD}^{xx} = \int_0^b (1) 1/EJ dx = [x]_0^b 1/EJ$$

$$= (b) 1/EJ = b/EJ$$

$$L_{DC}^{xx} = \int_0^b (1) 1/EJ dx = [x]_0^b 1/EJ$$

$$= (b) 1/EJ = b/EJ$$

$$L_{DE}^{xx} = \int_0^b (1 - 2x/b + x^2/b^2) 1/EJ dx = [x - x^2/b + 1/3 x^3/b^2]_0^b 1/EJ$$

$$= (b - b + 1/3 b) 1/EJ = 1/3 b/EJ$$

$$L_{ED}^{xx} = \int_0^b (x^2/b^2) 1/EJ dx = [1/3 x^3/b^2]_0^b 1/EJ$$

$$= (1/3 b) 1/EJ = 1/3 b/EJ$$

$$L_{BC}^{xo} = \int_0^b (5/2 x/b - 2x^2/b^2 + 1/2 x^3/b^3) Fb 1/EJ dx = [5/4 x^2/b - 2/3 x^3/b^2 + 1/8 x^4/b^3]_0^b Fb 1/EJ$$

$$= (5/4 b - 2/3 b + 1/8 b) Fb 1/EJ = 17/24 Fb^2/EJ$$

$$L_{CB}^{xo} = \int_0^b (1 - 1/2 x^2/b^2 - 1/2 x^3/b^3) Fb 1/EJ dx = [x - 1/6 x^3/b^2 - 1/8 x^4/b^3]_0^b Fb 1/EJ$$

$$= (b - 1/6 b - 1/8 b) Fb 1/EJ = 17/24 Fb^2/EJ$$

$$L_{DE}^{xo} = \int_0^b (x/b - x^2/b^2) Fb 1/EJ dx = [1/2 x^2/b - 1/3 x^3/b^2]_0^b Fb 1/EJ$$

$$= (1/2 b - 1/3 b) Fb 1/EJ = 1/6 Fb^2/EJ$$

$$L_{ED}^{xo} = \int_0^b (x/b - x^2/b^2) Fb 1/EJ dx = [1/2 x^2/b - 1/3 x^3/b^2]_0^b Fb 1/EJ$$

$$= (1/2 b - 1/3 b) Fb 1/EJ = 1/6 Fb^2/EJ$$

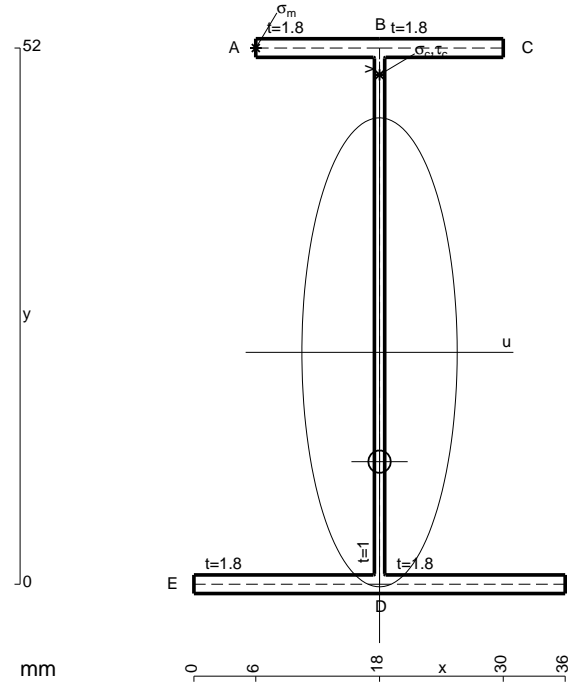

- A = 160. mm²
- J_u = 82754. mm⁴
- J_v = 9072. mm⁴
- J_t = 134. mm⁴
- y_o = -10.6 mm
- y_g = 22.49 mm
- N = -930. N
- T_y = -775. N
- M_x = -604500. Nmm
- x_m = 6. mm
- y_m = 52. mm
- u_m = -12. mm
- v_m = 29.51 mm
- σ_m = N/A-Mv/J_u = 209.8 N/mm²
- x_c = 18. mm
- y_c = 52. mm
- v_c = 29.51 mm
- σ_c = N/A-Mv/J_u = 209.8 N/mm²
- τ_c = TS'/tJ_u = 11.94 N/mm²
- τ_g = TS'/tJ_u = 11.94 N/mm²
- t_c = 310. mm
- σ_o = √σ²+3τ² = 210.8 N/mm²

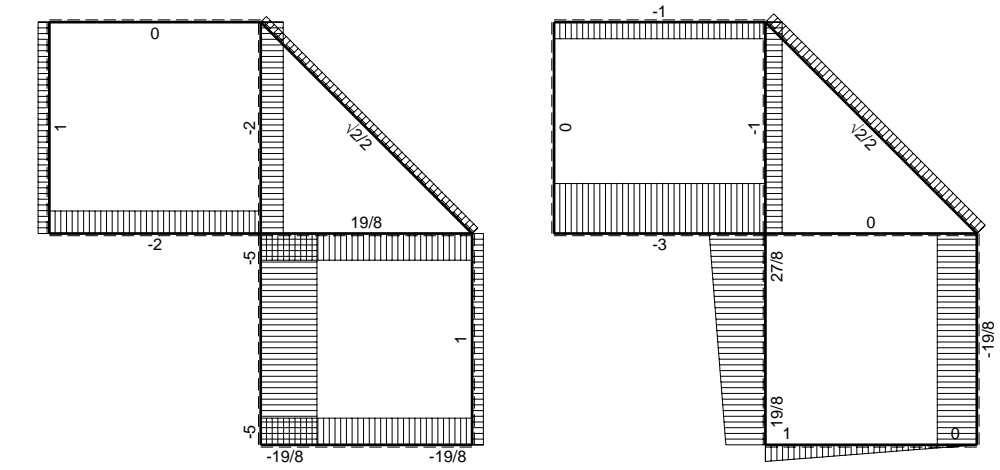
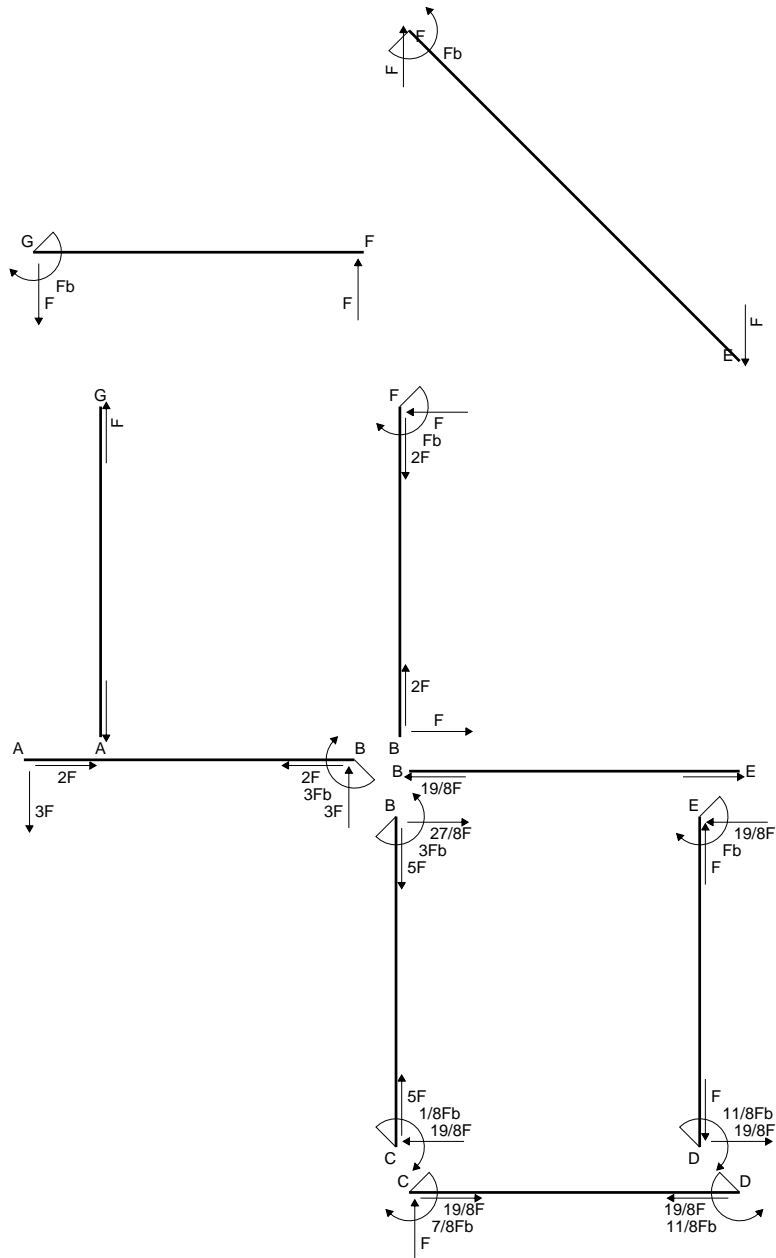

← ⊕ → F

↑ ⊕ ↓ F

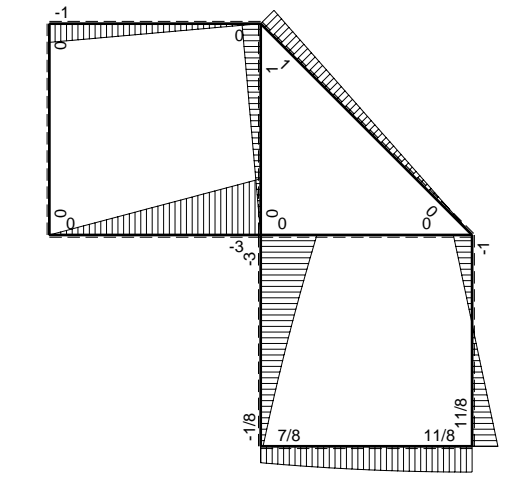

⊕ ⊖ F_b

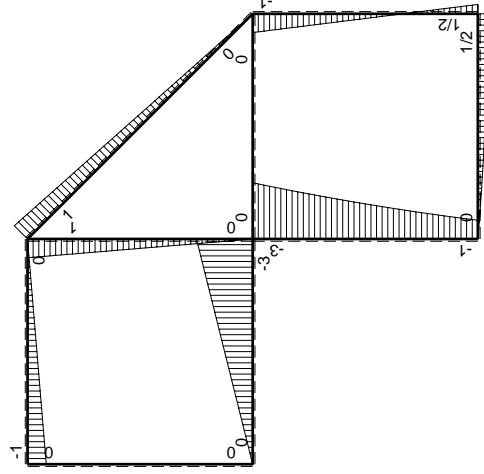
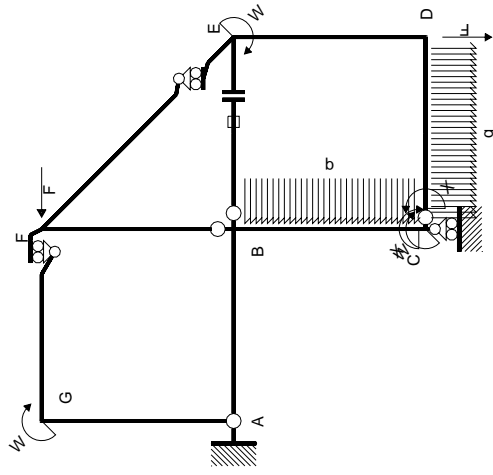

Schema di calcolo iperstatico

(\oplus) M_0 flessione da carichi assegnati

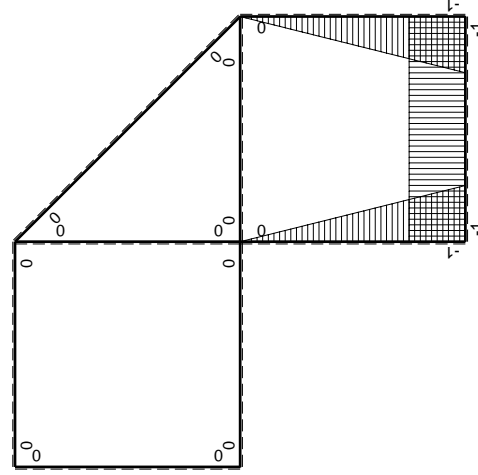

(\oplus) M_x flessione da iperstatica X=1

Quadro contributi PLV per iperstatica X=W_{CD}

→	$M_x(x)$	$M_0(x)$	$M_x M_0$	$M_x M_x$	$\int M_x M_0 / EJ dx$	$\int X M_x M_x / EJ dx$
AB b	0	-3Fx	0	0	0	0
BA b	0	3Fb-3Fx	0	0	0	0
BC b	-x/b	-3Fb+5/2Fx-1/2qx ²	3Fx-5/2Fx ² /b+1/2qx ³ /b	x ² /b ²	19/24Fb ² /EJ	1/3Xb/EJ
CB b	1-x/b	Fb+3/2Fx+1/2qx ²	Fb+1/2Fx-Fx ² /b-1/2qx ³ /b	1-2x/b+x ² /b ²		
CD b	-1	Fx-1/2qx ²	-Fx+1/2Fx ² /b	1	-1/3Fb ² /EJ	Xb/EJ
DC b	1	-1/2Fb+1/2qx ²	-1/2Fb+1/2Fx ² /b	1		
DE b	-1+x/b	1/2Fb-3/2Fx	-1/2Fb+2Fx-3/2Fx ² /b	1-2x/b+x ² /b ²	0	1/3Xb/EJ
ED b	x/b	Fb-3/2Fx	Fx-3/2Fx ² /b	x ² /b ²	0	1/3Xb/EJ
EF √2b	0	√2/2Fx	0	0	0	0
FG b	0	-Fx	0	0	0	0
GF b	0	Fb-Fx	0	0	0	0
GA b	0	0	0	0	0	0
AG b	0	0	0	0	0	0
FB b	0	Fb-Fx	0	0	0	0
BF b	0	-Fx	0	0	0	0
BE b	0	0	0	0	0	0
EB b	0	0	0	0	0	0
BE	elongazione asta $N_{1, BE} \epsilon_{BE} L_{BE}$				Fb ² /EJ	
	totali				35/24Fb ² /EJ	5/3Xb/EJ
	iperstatica X=W _{CD}				-7/8Fb	

Sviluppi di calcolo iperstatica

$$L_{BC}^{xx} = \int_0^b (x^2/b^2) 1/EJ dx = [1/3 x^3/b^2]_0^b 1/EJ$$

$$= (1/3 b) 1/EJ = 1/3 b/EJ$$

$$L_{CB}^{xx} = \int_0^b (1 - 2x/b + x^2/b^2) 1/EJ dx = [x - x^2/b + 1/3 x^3/b^2]_0^b 1/EJ$$

$$= (b - b + 1/3 b) 1/EJ = 1/3 b/EJ$$

$$L_{CD}^{xx} = \int_0^b (1) 1/EJ dx = [x]_0^b 1/EJ$$

$$= (b) 1/EJ = b/EJ$$

$$L_{DC}^{xx} = \int_0^b (1) 1/EJ dx = [x]_0^b 1/EJ$$

$$= (b) 1/EJ = b/EJ$$

$$L_{DE}^{xx} = \int_0^b (1 - 2x/b + x^2/b^2) 1/EJ dx = [x - x^2/b + 1/3 x^3/b^2]_0^b 1/EJ$$

$$= (b - b + 1/3 b) 1/EJ = 1/3 b/EJ$$

$$L_{ED}^{xx} = \int_0^b (x^2/b^2) 1/EJ dx = [1/3 x^3/b^2]_0^b 1/EJ$$

$$= (1/3 b) 1/EJ = 1/3 b/EJ$$

$$L_{BC}^{x_0} = \int_0^b (3x/b - 5/2 x^2/b^2 + 1/2 x^3/b^3) Fb 1/EJ dx = [3/2 x^2/b - 5/6 x^3/b^2 + 1/8 x^4/b^3]_0^b Fb 1/EJ$$

$$= (3/2 b - 5/6 b + 1/8 b) Fb 1/EJ = 19/24 Fb^2/EJ$$

$$L_{CB}^{x_0} = \int_0^b (1 + 1/2 x/b - x^2/b^2 - 1/2 x^3/b^3) Fb 1/EJ dx = [x + 1/4 x^2/b - 1/3 x^3/b^2 - 1/8 x^4/b^3]_0^b Fb 1/EJ$$

$$= (b + 1/4 b - 1/3 b - 1/8 b) Fb 1/EJ = 19/24 Fb^2/EJ$$

$$L_{CD}^{x_0} = \int_0^b (-x/b + 1/2 x^2/b^2) Fb 1/EJ dx = [-1/2 x^2/b + 1/6 x^3/b^2]_0^b Fb 1/EJ$$

$$= (-1/2 b + 1/6 b) Fb 1/EJ = -1/3 Fb^2/EJ$$

$$L_{DC}^{x_0} = \int_0^b (-1/2 + 1/2 x^2/b^2) Fb 1/EJ dx = [-1/2 x + 1/6 x^3/b^2]_0^b Fb 1/EJ$$

$$= (-1/2 b + 1/6 b) Fb 1/EJ = -1/3 Fb^2/EJ$$

$$L_{DE}^{x_0} = \int_0^b (-1/2 + 2x/b - 3/2 x^2/b^2) Fb 1/EJ dx = [-1/2 x + x^2/b - 1/2 x^3/b^2]_0^b Fb 1/EJ$$

$$= (-1/2 b + b - 1/2 b) Fb 1/EJ = 0$$

$$L_{ED}^{x_0} = \int_0^b (x/b - 3/2 x^2/b^2) Fb 1/EJ dx = [1/2 x^2/b - 1/2 x^3/b^2]_0^b Fb 1/EJ$$

$$= (1/2 b - 1/2 b) Fb 1/EJ = 0$$

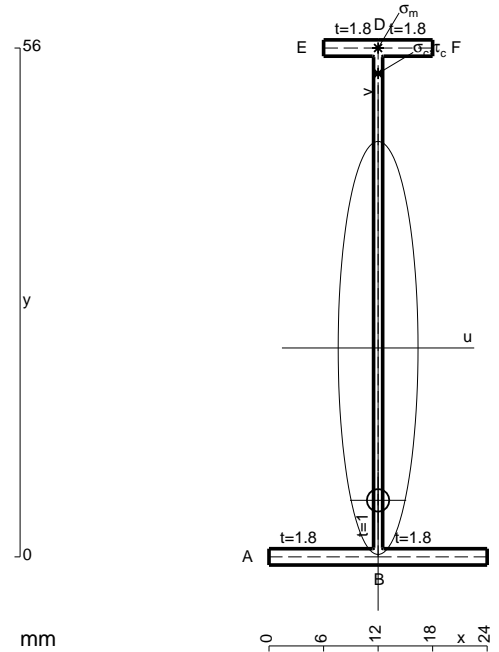

- A = 120.8 mm²
- J_u = 62410. mm⁴
- J_v = 2333. mm⁴
- J_t = 88.65 mm⁴
- y_o = -16.77 mm
- y_g = 22.99 mm
- N = -300. N
- T_y = -450. N
- M_x = -405000. Nmm
- x_m = 12. mm
- y_m = 56. mm
- v_m = 33.01 mm
- σ_m = N/A-Mv/J_u = 211.7 N/mm²
- y_c = 2. mm
- u_c = -12. mm
- v_c = -20.99 mm
- σ_c = N/A-Mv/J_u = 211.7 N/mm²
- τ_c = TS_t/tJ_u = 5.141 N/mm²
- τ_g = TS_t/tJ_u = 5.141 N/mm²
- t_c = 150. mm
- σ_o = √σ²+3τ² = 211.9 N/mm²

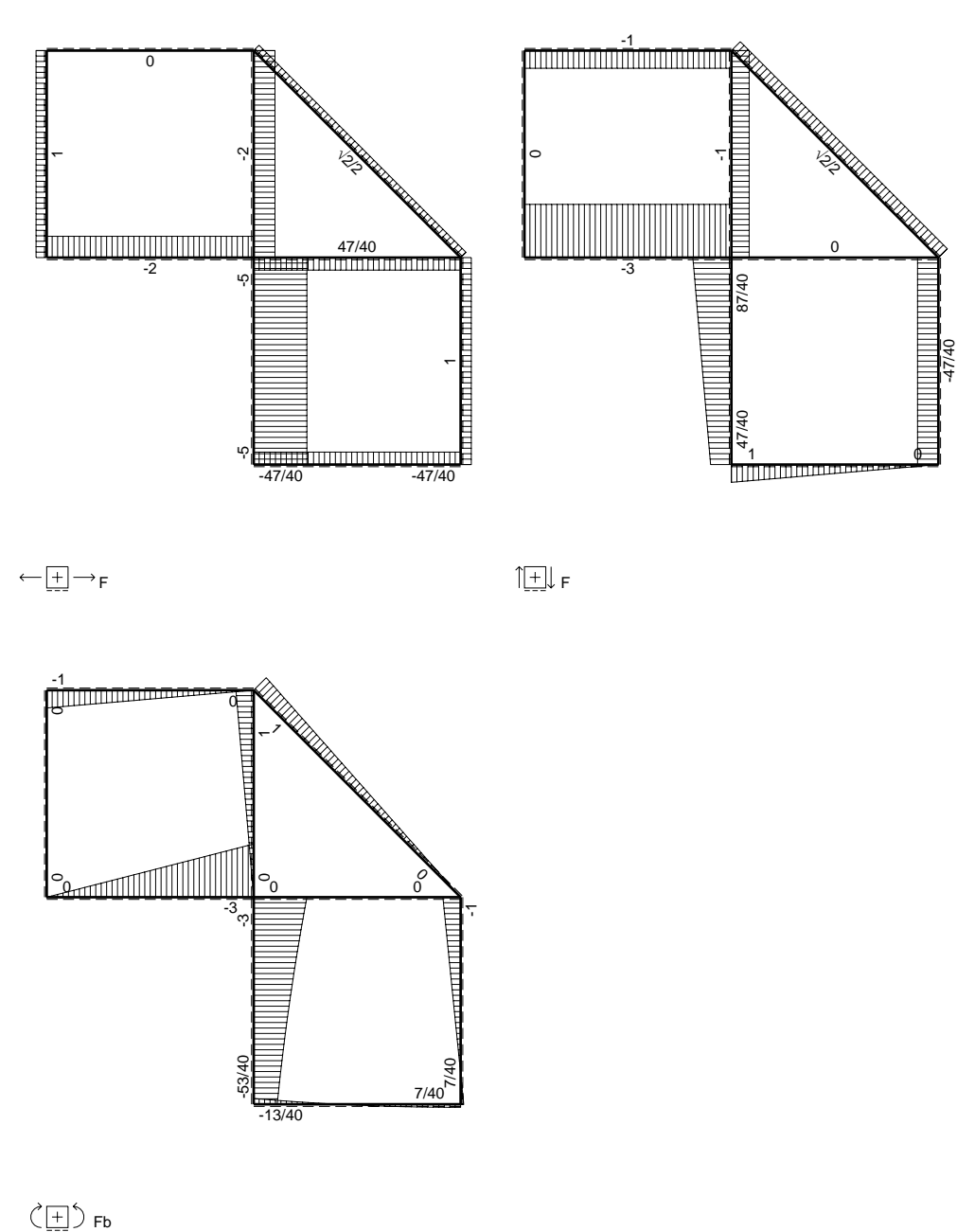
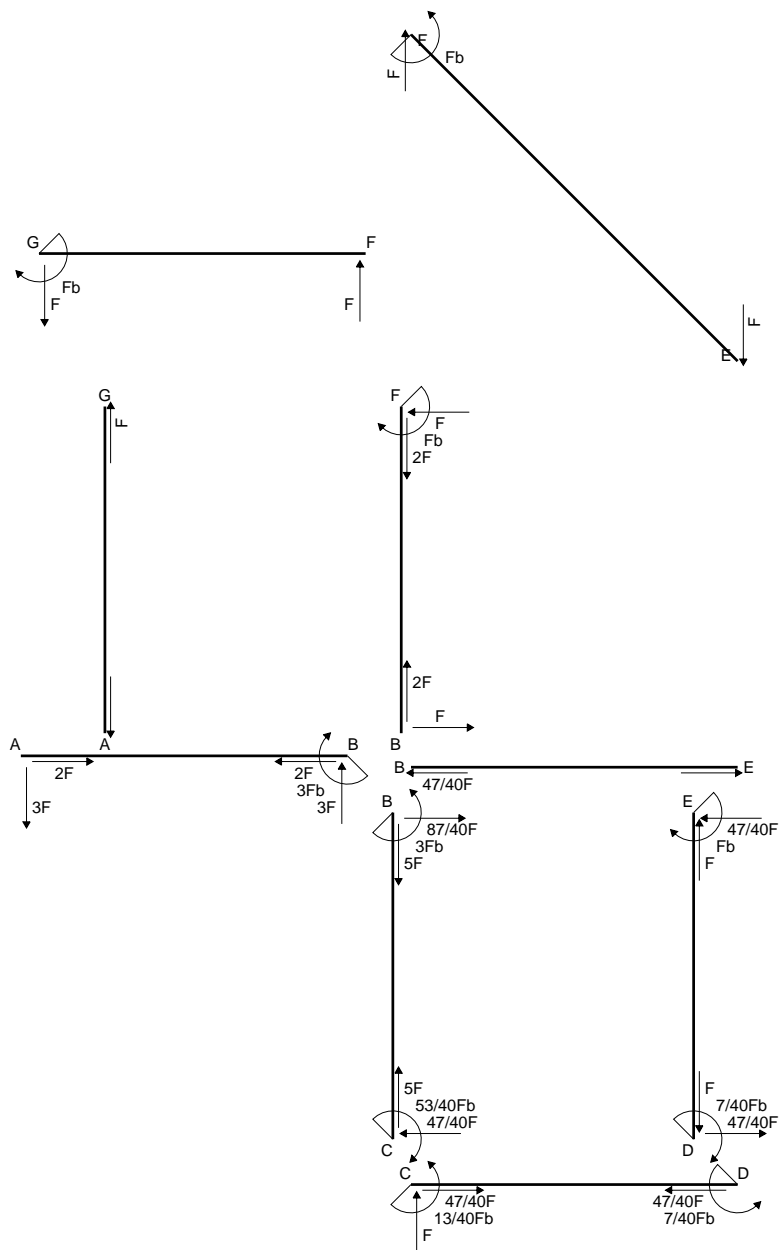

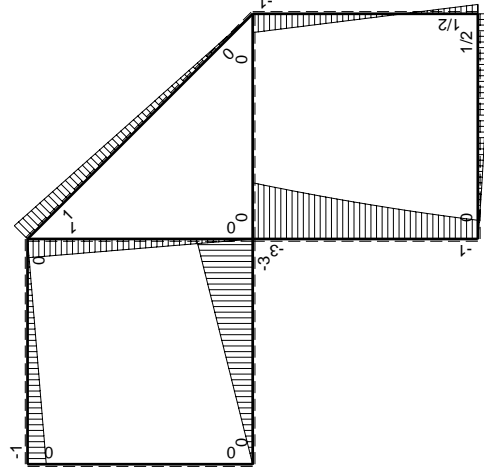
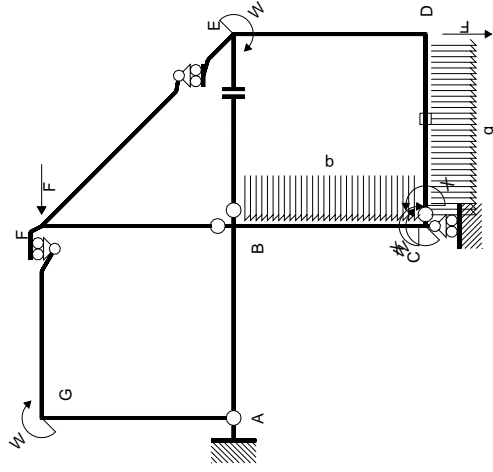

Schema di calcolo iperstatico

M_0 flessione da carichi assegnati

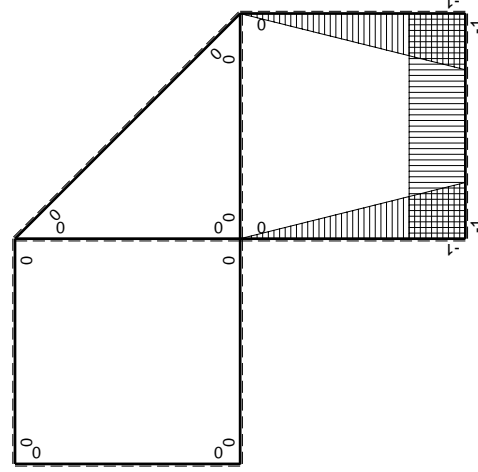

M_x flessione da iperstatica $X=1$

Quadro contributi PLV per iperstatica $X=W_{cd}$

\rightarrow	$M_x(x)$	$M_0(x)$	$M_x M_0$	$M_x M_x$	$\int M_x M_0 / EJ dx$	$\int X M_x M_x / EJ dx$
AB b	0	-3Fx	0	0	0	0
BA b	0	3Fb-3Fx	0	0	0	0
BC b	-x/b	$-3Fb+5/2Fx-1/2qx^2$	$3Fx-5/2Fx^2/b+1/2qx^3/b$	x^2/b^2	$19/24Fb^2/EJ$	$1/3Xb/EJ$
CB b	1-x/b	$Fb+3/2Fx+1/2qx^2$	$Fb+1/2Fx-Fx^2/b-1/2qx^3/b$	$1-2x/b+x^2/b^2$		
CD b	-1	$Fx-1/2qx^2$	$-Fx+1/2Fx^2/b$	1	$-1/3Fb^2/EJ$	Xb/EJ
DC b	1	$-1/2Fb+1/2qx^2$	$-1/2Fb+1/2Fx^2/b$	1		
DE b	-1+x/b	$1/2Fb-3/2Fx$	$-1/2Fb+2Fx-3/2Fx^2/b$	$1-2x/b+x^2/b^2$	0	$1/3Xb/EJ$
ED b	x/b	$Fb-3/2Fx$	$Fx-3/2Fx^2/b$	x^2/b^2		
EF $\sqrt{2}b$	0	$\sqrt{2}/2Fx$	0	0	0	0
FG b	0	-Fx	0	0	0	0
GF b	0	Fb-Fx	0	0	0	0
GA b	0	0	0	0	0	0
AG b	0	0	0	0	0	0
FB b	0	Fb-Fx	0	0	0	0
BF b	0	-Fx	0	0	0	0
BE b	0	0	0	0	0	0
EB b	0	0	0	0	0	0
CD	elongazione asta $N_{1,cd} \epsilon_{cd} l_{cd}$				$-Fb^2/EJ$	
	totali				$-13/24Fb^2/EJ$	$5/3Xb/EJ$
	iperstatica $X=W_{cd}$				13/40Fb	

Sviluppi di calcolo iperstatica

$$L_{BC}^{xx} = \int_0^b (x^2/b^2) 1/EJ dx = [1/3 x^3/b^2]_0^b 1/EJ$$

$$= (1/3 b) 1/EJ = 1/3 b/EJ$$

$$L_{CB}^{xx} = \int_0^b (1 - 2x/b + x^2/b^2) 1/EJ dx = [x - x^2/b + 1/3 x^3/b^2]_0^b 1/EJ$$

$$= (b - b + 1/3 b) 1/EJ = 1/3 b/EJ$$

$$L_{CD}^{xx} = \int_0^b (1) 1/EJ dx = [x]_0^b 1/EJ$$

$$= (b) 1/EJ = b/EJ$$

$$L_{DC}^{xx} = \int_0^b (1) 1/EJ dx = [x]_0^b 1/EJ$$

$$= (b) 1/EJ = b/EJ$$

$$L_{DE}^{xx} = \int_0^b (1 - 2x/b + x^2/b^2) 1/EJ dx = [x - x^2/b + 1/3 x^3/b^2]_0^b 1/EJ$$

$$= (b - b + 1/3 b) 1/EJ = 1/3 b/EJ$$

$$L_{ED}^{xx} = \int_0^b (x^2/b^2) 1/EJ dx = [1/3 x^3/b^2]_0^b 1/EJ$$

$$= (1/3 b) 1/EJ = 1/3 b/EJ$$

$$L_{BC}^{x_0} = \int_0^b (3x/b - 5/2 x^2/b^2 + 1/2 x^3/b^3) Fb 1/EJ dx = [3/2 x^2/b - 5/6 x^3/b^2 + 1/8 x^4/b^3]_0^b Fb 1/EJ$$

$$= (3/2 b - 5/6 b + 1/8 b) Fb 1/EJ = 19/24 Fb^2/EJ$$

$$L_{CB}^{x_0} = \int_0^b (1 + 1/2 x/b - x^2/b^2 - 1/2 x^3/b^3) Fb 1/EJ dx = [x + 1/4 x^2/b - 1/3 x^3/b^2 - 1/8 x^4/b^3]_0^b Fb 1/EJ$$

$$= (b + 1/4 b - 1/3 b - 1/8 b) Fb 1/EJ = 19/24 Fb^2/EJ$$

$$L_{CD}^{x_0} = \int_0^b (-x/b + 1/2 x^2/b^2) Fb 1/EJ dx + 1 (-1) 1 Fb^2/EJ$$

$$= [-1/2 x^2/b + 1/6 x^3/b^2]_0^b Fb 1/EJ + 1 (-1) 1 Fb^2/EJ$$

$$= (-1/2 b + 1/6 b) Fb 1/EJ + 1 (-1) 1 Fb^2/EJ = -4/3 Fb^2/EJ$$

$$L_{DC}^{x_0} = \int_0^b (-1/2 + 1/2 x^2/b^2) Fb 1/EJ dx + 1 (-1) 1 Fb^2/EJ$$

$$= [-1/2 x + 1/6 x^3/b^2]_0^b Fb 1/EJ + 1 (-1) 1 Fb^2/EJ$$

$$= (-1/2 b + 1/6 b) Fb 1/EJ + 1 (-1) 1 Fb^2/EJ = -4/3 Fb^2/EJ$$

$$L_{DE}^{x_0} = \int_0^b (-1/2 + 2x/b - 3/2 x^2/b^2) Fb 1/EJ dx = [-1/2 x + x^2/b - 1/2 x^3/b^2]_0^b Fb 1/EJ$$

$$= (-1/2 b + b - 1/2 b) Fb 1/EJ = 0$$

$$L_{ED}^{x_0} = \int_0^b (x/b - 3/2 x^2/b^2) Fb 1/EJ dx = [1/2 x^2/b - 1/2 x^3/b^2]_0^b Fb 1/EJ$$

$$= (1/2 b - 1/2 b) Fb 1/EJ = 0$$

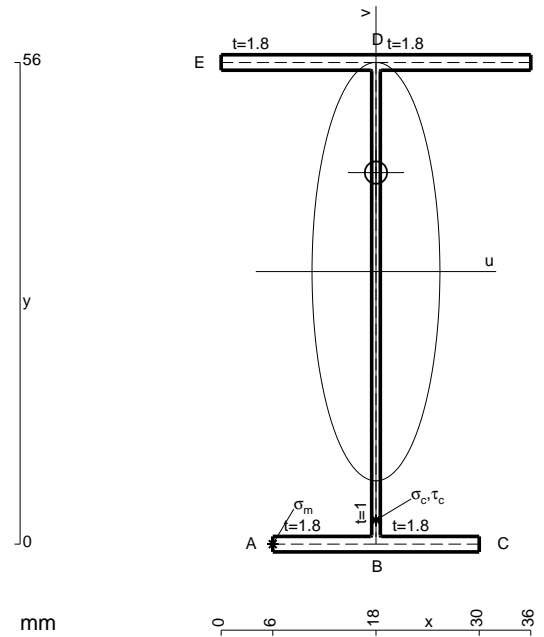

- A = 164. mm²
- J_u = 97076. mm⁴
- J_v = 9072. mm⁴
- J_t = 135.3 mm⁴
- y_o = 11.51 mm
- y_g = 31.69 mm
- N = -480. N
- T_y = -720. N
- M_x = -684000. Nmm
- x_m = 6. mm
- u_m = -12. mm
- v_m = -31.69 mm
- σ_m = N/A-Mv/J_u = -226.2 N/mm²
- x_c = 18. mm
- v_c = -31.69 mm
- σ_c = N/A-Mv/J_u = -226.2 N/mm²
- τ_c = TS/tJ_u = 10.15 N/mm²
- τ_g = TS/tJ_u = 10.15 N/mm²
- t_c = 240. mm
- σ_o = √σ²+3τ² = 226.9 N/mm²

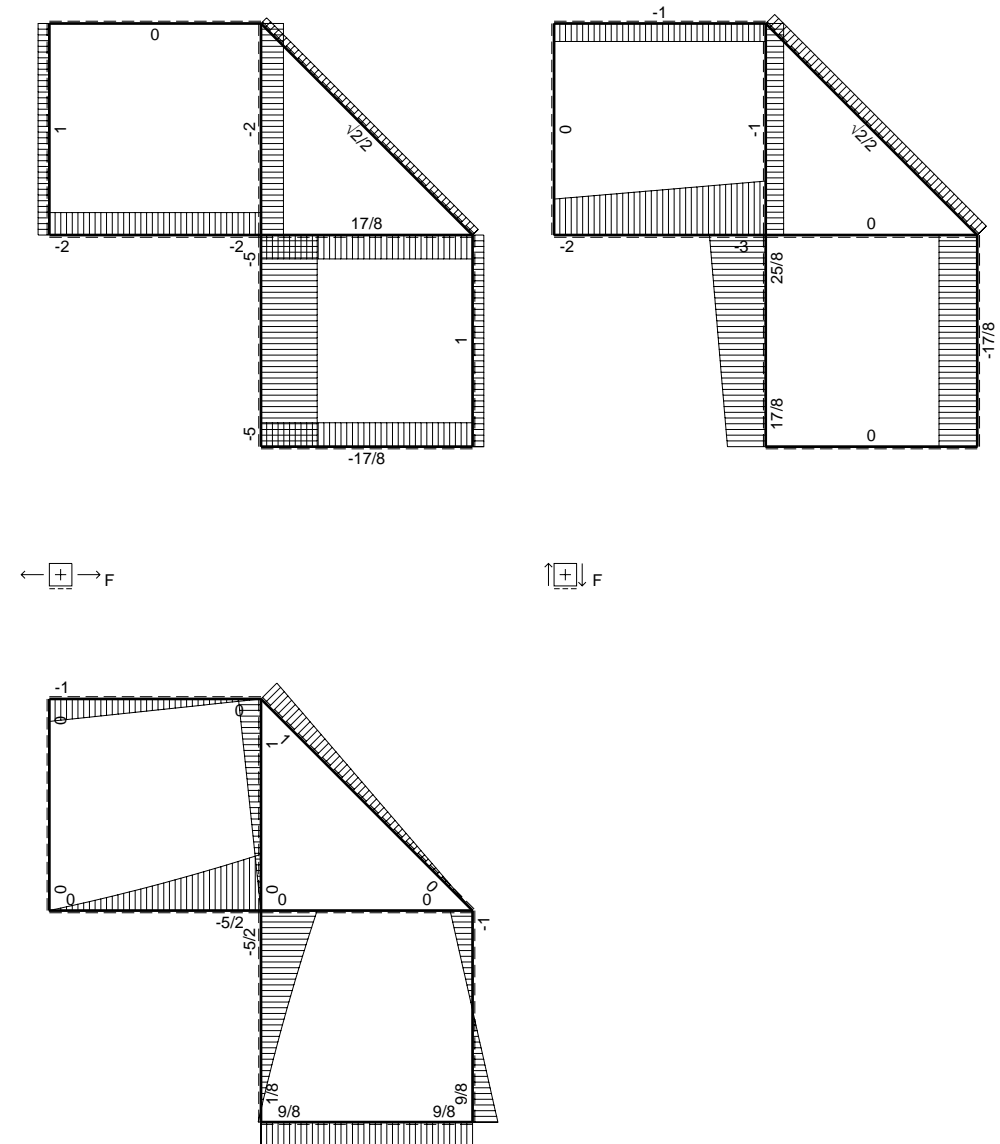
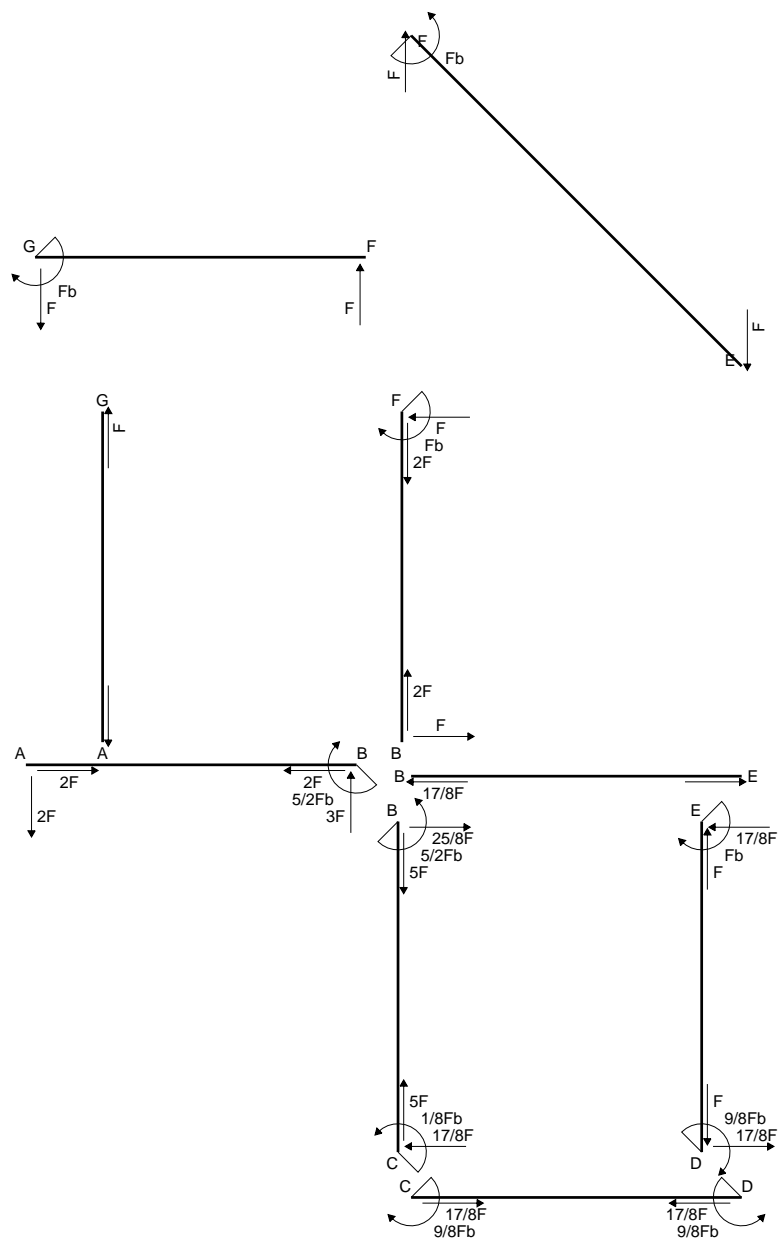

⊕ F_b

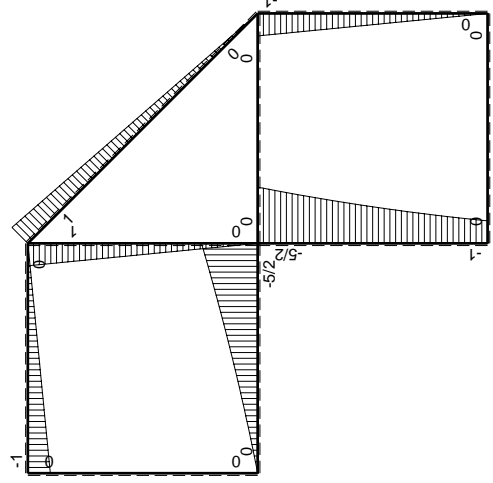
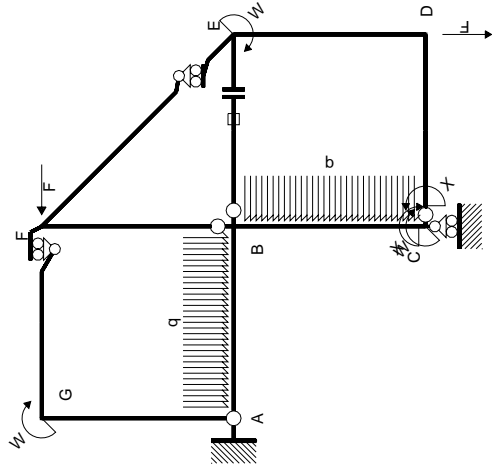

Schema di calcolo iperstatico

M_0 flessione da carichi assegnati

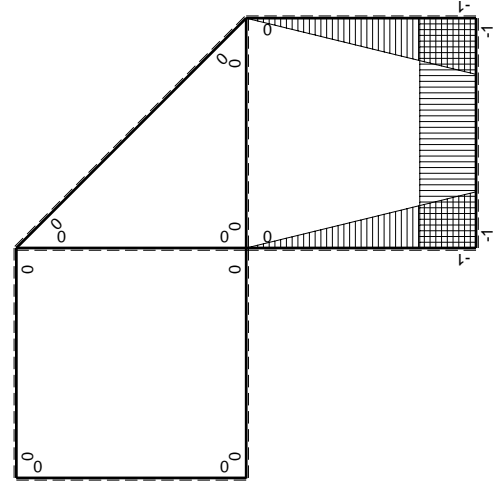

M_x flessione da iperstatica X=1

Quadro contributi PLV per iperstatica X=W_{cd}

→	$M_x(x)$	$M_0(x)$	$M_x M_0$	$M_x M_x$	$\int M_x M_0 / E J dx$	$\int X M_x M_x / E J dx$
AB b	0	$-2Fx - 1/2qx^2$	0	0	0	0
BA b	0	$5/2Fb - 3Fx + 1/2qx^2$	0	0	0	0
BC b	$-x/b$	$-5/2Fb + 2Fx - 1/2qx^2$	$5/2Fx - 2Fx^2/b + 1/2qx^3/b$	x^2/b^2	$17/24Fb^2/EJ$	$1/3Xb/EJ$
CB b	$1-x/b$	$Fb + Fx + 1/2qx^2$	$Fb - 1/2Fx^2/b - 1/2qx^3/b$	$1 - 2x/b + x^2/b^2$	0	Xb/EJ
CD b	-1	0	0	1	0	0
DC b	1	0	0	1	0	0
DE b	$-1+x/b$	-Fx	$Fx - Fx^2/b$	$1 - 2x/b + x^2/b^2$	$1/6Fb^2/EJ$	$1/3Xb/EJ$
ED b	x/b	$Fb - Fx$	$Fx - Fx^2/b$	x^2/b^2	0	0
EF $\sqrt{2}b$	0	$\sqrt{2}/2Fx$	0	0	0	0
FG b	0	-Fx	0	0	0	0
GF b	0	$Fb - Fx$	0	0	0	0
GA b	0	0	0	0	0	0
AG b	0	0	0	0	0	0
FB b	0	$Fb - Fx$	0	0	0	0
BF b	0	-Fx	0	0	0	0
BE b	0	0	0	0	0	0
EB b	0	0	0	0	0	0
BE	elongazione asta $N_{1, BE} \epsilon_{BE} L_{BE}$				Fb^2/EJ	
	totali				$15/8Fb^2/EJ$	$5/3Xb/EJ$
	iperstatica X=W _{cd}				-9/8Fb	

Sviluppi di calcolo iperstatica

$$L_{BC}^{xx} = \int_0^b (x^2/b^2) 1/EJ dx = [1/3 x^3/b^2]_0^b 1/EJ$$

$$= (1/3 b) 1/EJ = 1/3 b/EJ$$

$$L_{CB}^{xx} = \int_0^b (1 - 2x/b + x^2/b^2) 1/EJ dx = [x - x^2/b + 1/3 x^3/b^2]_0^b 1/EJ$$

$$= (b - b + 1/3 b) 1/EJ = 1/3 b/EJ$$

$$L_{CD}^{xx} = \int_0^b (1) 1/EJ dx = [x]_0^b 1/EJ$$

$$= (b) 1/EJ = b/EJ$$

$$L_{DC}^{xx} = \int_0^b (1) 1/EJ dx = [x]_0^b 1/EJ$$

$$= (b) 1/EJ = b/EJ$$

$$L_{DE}^{xx} = \int_0^b (1 - 2x/b + x^2/b^2) 1/EJ dx = [x - x^2/b + 1/3 x^3/b^2]_0^b 1/EJ$$

$$= (b - b + 1/3 b) 1/EJ = 1/3 b/EJ$$

$$L_{ED}^{xx} = \int_0^b (x^2/b^2) 1/EJ dx = [1/3 x^3/b^2]_0^b 1/EJ$$

$$= (1/3 b) 1/EJ = 1/3 b/EJ$$

$$L_{BC}^{x_0} = \int_0^b (5/2 x/b - 2x^2/b^2 + 1/2 x^3/b^3) Fb 1/EJ dx = [5/4 x^2/b - 2/3 x^3/b^2 + 1/8 x^4/b^3]_0^b Fb 1/EJ$$

$$= (5/4 b - 2/3 b + 1/8 b) Fb 1/EJ = 17/24 Fb^2/EJ$$

$$L_{CB}^{x_0} = \int_0^b (1 - 1/2 x^2/b^2 - 1/2 x^3/b^3) Fb 1/EJ dx = [x - 1/6 x^3/b^2 - 1/8 x^4/b^3]_0^b Fb 1/EJ$$

$$= (b - 1/6 b - 1/8 b) Fb 1/EJ = 17/24 Fb^2/EJ$$

$$L_{DE}^{x_0} = \int_0^b (x/b - x^2/b^2) Fb 1/EJ dx = [1/2 x^2/b - 1/3 x^3/b^2]_0^b Fb 1/EJ$$

$$= (1/2 b - 1/3 b) Fb 1/EJ = 1/6 Fb^2/EJ$$

$$L_{ED}^{x_0} = \int_0^b (x/b - x^2/b^2) Fb 1/EJ dx = [1/2 x^2/b - 1/3 x^3/b^2]_0^b Fb 1/EJ$$

$$= (1/2 b - 1/3 b) Fb 1/EJ = 1/6 Fb^2/EJ$$

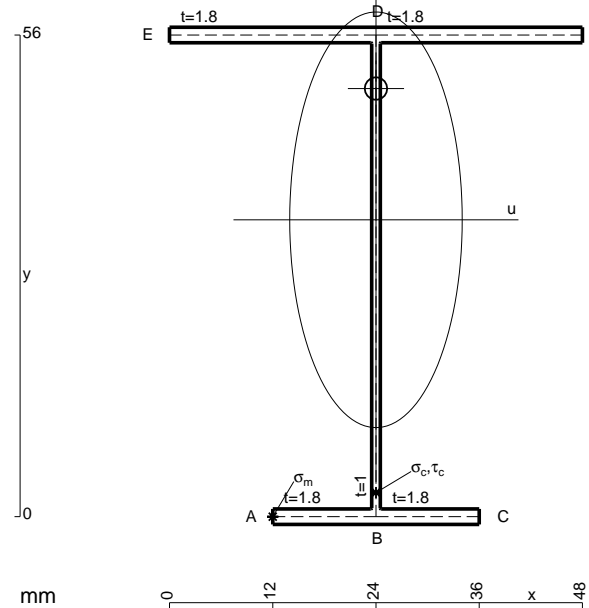

- A = 185.6 mm²
- J_u = 108358. mm⁴
- J_v = 18662. mm⁴
- J_I = 158.6 mm⁴
- y_o = 15.26 mm
- y_g = 34.52 mm
- N = -580. N
- T_y = -870. N
- M_x = -725000. Nmm
- x_m = 12. mm
- u_m = -12. mm
- v_m = -34.52 mm
- σ_m = N/A-Mv/J_u = -234.1 N/mm²
- x_c = 24. mm
- v_c = -34.52 mm
- σ_c = N/A-Mv/J_u = -234.1 N/mm²
- τ_c = TS^{*}/tJ_u = 11.97 N/mm²
- τ_g = TS^{*}/tJ_u = 11.97 N/mm²
- t_c = 290. mm
- σ_o = √σ²+3τ² = 235. N/mm²

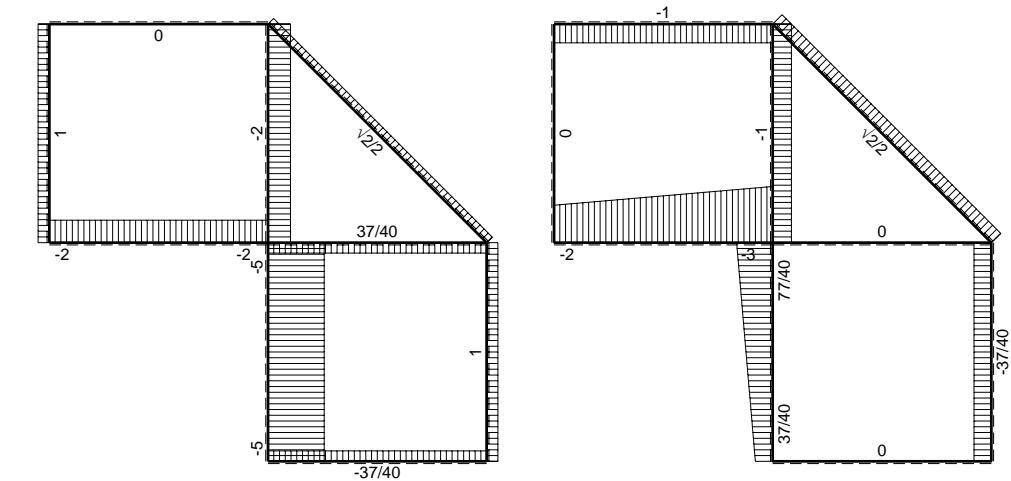
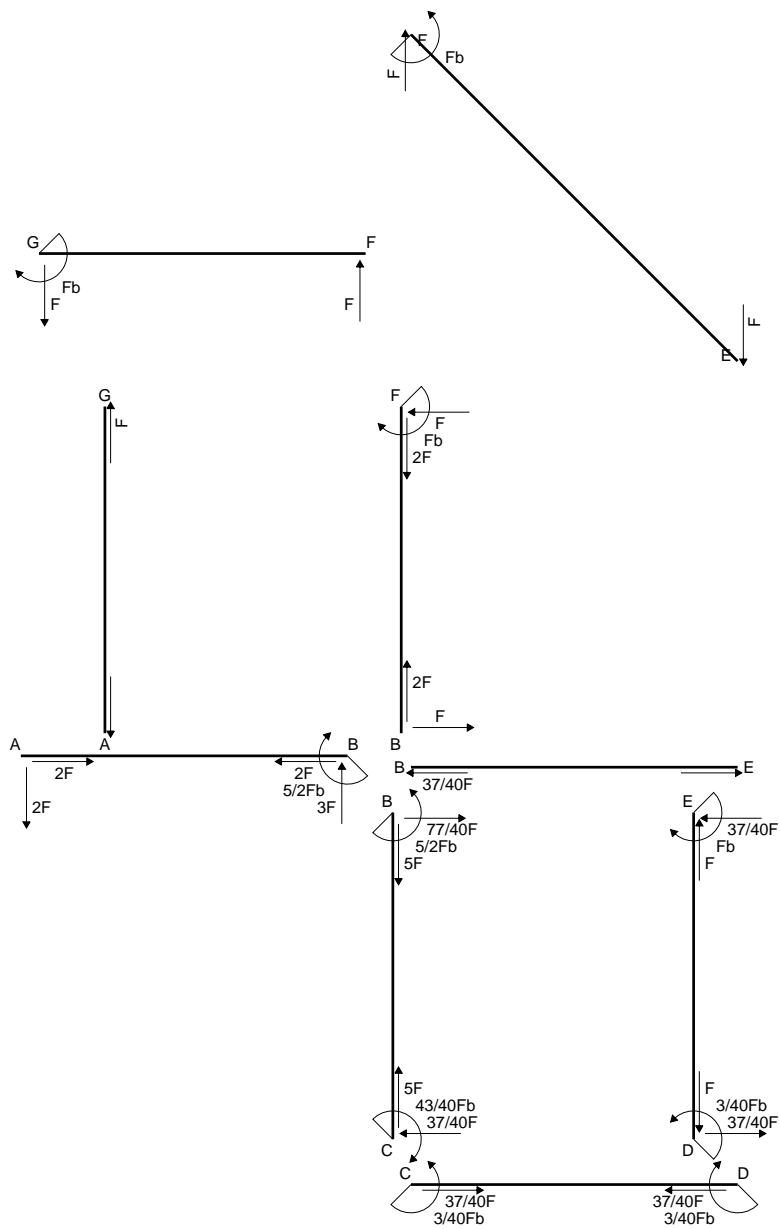

← ⊕ → F

↑ ⊕ ↓ F

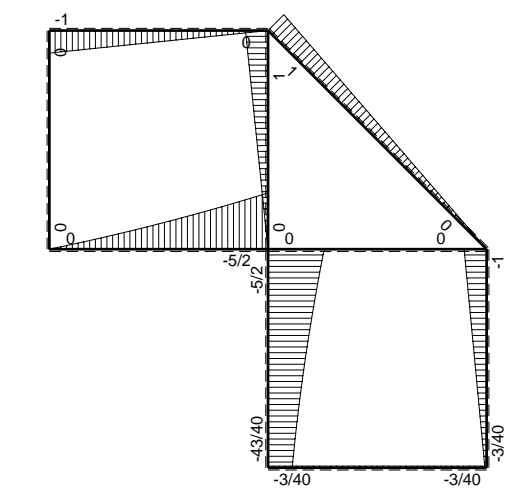

⊕ ⊖ Fb

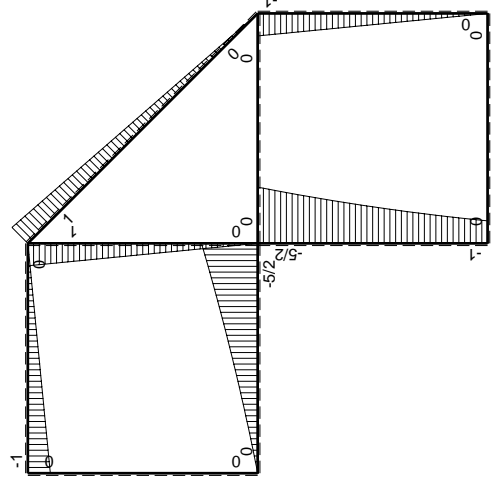
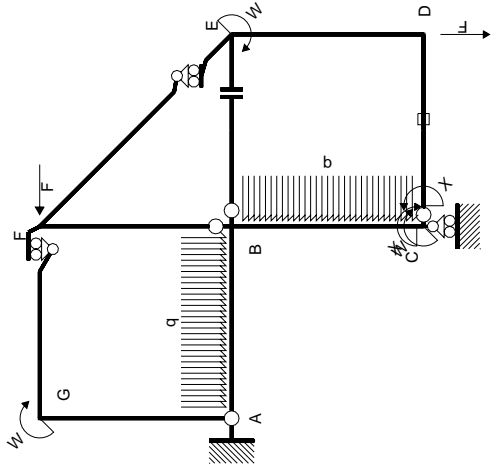

Schema di calcolo iperstatico

(\oplus) M_0 flessione da carichi assegnati

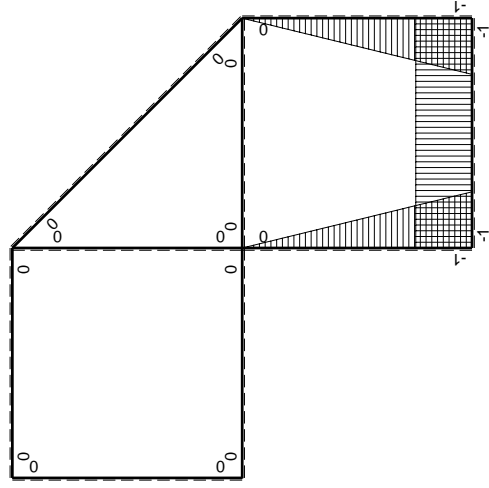

(\oplus) M_x flessione da iperstatica X=1

Quadro contributi PLV per iperstatica X=W_{cd}

→	$M_x(x)$	$M_0(x)$	$M_x M_0$	$M_x M_x$	$\int M_x M_0 / E J dx$	$\int M_x M_x / E J dx$
AB b	0	$-2Fx - 1/2qx^2$	0	0	0	0
BA b	0	$5/2Fb - 3Fx + 1/2qx^2$	0	0	0	0
BC b	$-x/b$	$-5/2Fb + 2Fx - 1/2qx^2$	$5/2Fx - 2Fx^2/b + 1/2qx^3/b$	x^2/b^2	$17/24Fb^2/EJ$	$1/3Xb/EJ$
CB b	$1-x/b$	$Fb + Fx + 1/2qx^2$	$Fb - 1/2Fx^2/b - 1/2qx^3/b$	$1 - 2x/b + x^2/b^2$	0	Xb/EJ
CD b	-1	0	0	1	0	0
DC b	1	0	0	1	0	0
DE b	$-1+x/b$	-Fx	$Fx - Fx^2/b$	$1 - 2x/b + x^2/b^2$	$1/6Fb^2/EJ$	$1/3Xb/EJ$
ED b	x/b	$Fb - Fx$	$Fx - Fx^2/b$	x^2/b^2	0	0
EF $\sqrt{2}b$	0	$\sqrt{2}/2Fx$	0	0	0	0
FG b	0	-Fx	0	0	0	0
GF b	0	$Fb - Fx$	0	0	0	0
GA b	0	0	0	0	0	0
AG b	0	0	0	0	0	0
FB b	0	$Fb - Fx$	0	0	0	0
BF b	0	-Fx	0	0	0	0
BE b	0	0	0	0	0	0
EB b	0	0	0	0	0	0
CD	elongazione asta $N_{1,cd} \epsilon_{cd} l_{cd}$				$-Fb^2/EJ$	
	totali				$-1/8Fb^2/EJ$	$5/3Xb/EJ$
	iperstatica X=W _{cd}				$3/40Fb$	

Sviluppi di calcolo iperstatica

$$L_{BC}^{xx} = \int_0^b (x^2/b^2) 1/EJ dx = [1/3 x^3/b^2]_0^b 1/EJ$$

$$= (1/3 b) 1/EJ = 1/3 b/EJ$$

$$L_{CB}^{xx} = \int_0^b (1 - 2x/b + x^2/b^2) 1/EJ dx = [x - x^2/b + 1/3 x^3/b^2]_0^b 1/EJ$$

$$= (b - b + 1/3 b) 1/EJ = 1/3 b/EJ$$

$$L_{CD}^{xx} = \int_0^b (1) 1/EJ dx = [x]_0^b 1/EJ$$

$$= (b) 1/EJ = b/EJ$$

$$L_{DC}^{xx} = \int_0^b (1) 1/EJ dx = [x]_0^b 1/EJ$$

$$= (b) 1/EJ = b/EJ$$

$$L_{DE}^{xx} = \int_0^b (1 - 2x/b + x^2/b^2) 1/EJ dx = [x - x^2/b + 1/3 x^3/b^2]_0^b 1/EJ$$

$$= (b - b + 1/3 b) 1/EJ = 1/3 b/EJ$$

$$L_{ED}^{xx} = \int_0^b (x^2/b^2) 1/EJ dx = [1/3 x^3/b^2]_0^b 1/EJ$$

$$= (1/3 b) 1/EJ = 1/3 b/EJ$$

$$L_{BC}^{xo} = \int_0^b (5/2 x/b - 2x^2/b^2 + 1/2 x^3/b^3) Fb 1/EJ dx = [5/4 x^2/b - 2/3 x^3/b^2 + 1/8 x^4/b^3]_0^b Fb 1/EJ$$

$$= (5/4 b - 2/3 b + 1/8 b) Fb 1/EJ = 17/24 Fb^2/EJ$$

$$L_{CB}^{xo} = \int_0^b (1 - 1/2 x^2/b^2 - 1/2 x^3/b^3) Fb 1/EJ dx = [x - 1/6 x^3/b^2 - 1/8 x^4/b^3]_0^b Fb 1/EJ$$

$$= (b - 1/6 b - 1/8 b) Fb 1/EJ = 17/24 Fb^2/EJ$$

$$L_{DE}^{xo} = \int_0^b (x/b - x^2/b^2) Fb 1/EJ dx = [1/2 x^2/b - 1/3 x^3/b^2]_0^b Fb 1/EJ$$

$$= (1/2 b - 1/3 b) Fb 1/EJ = 1/6 Fb^2/EJ$$

$$L_{ED}^{xo} = \int_0^b (x/b - x^2/b^2) Fb 1/EJ dx = [1/2 x^2/b - 1/3 x^3/b^2]_0^b Fb 1/EJ$$

$$= (1/2 b - 1/3 b) Fb 1/EJ = 1/6 Fb^2/EJ$$

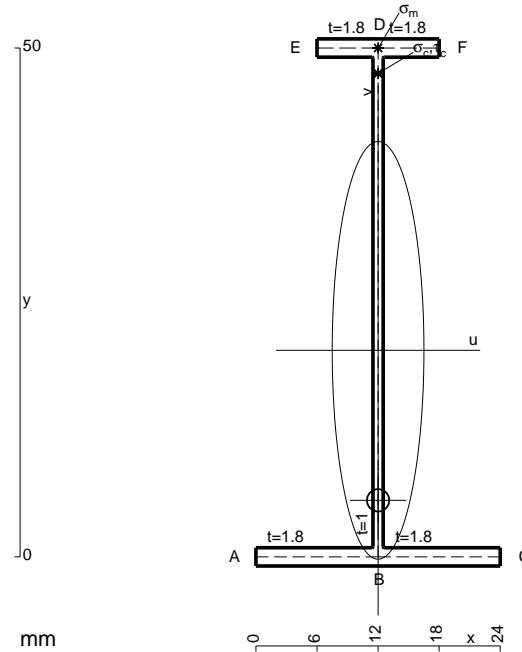

- A = 114.8 mm²
- J_u = 48377. mm⁴
- J_v = 2333. mm⁴
- J_t = 86.65 mm⁴
- y_o = -14.74 mm
- y_g = 20.3 mm
- N = -560. N
- T_y = -840. N
- M_x = -329000. Nmm
- x_m = 12. mm
- y_m = 50. mm
- v_m = 29.7 mm
- σ_m = N/A-Mv/J_u = 197.1 N/mm²
- y_c = 2. mm
- u_c = -12. mm
- v_c = -18.3 mm
- σ_c = N/A-Mv/J_u = 197.1 N/mm²
- τ_c = TS/tJ_u = 11.14 N/mm²
- τ_g = TS/tJ_u = 11.14 N/mm²
- t_c = 280. mm
- σ_o = √σ²+3τ² = 198.1 N/mm²

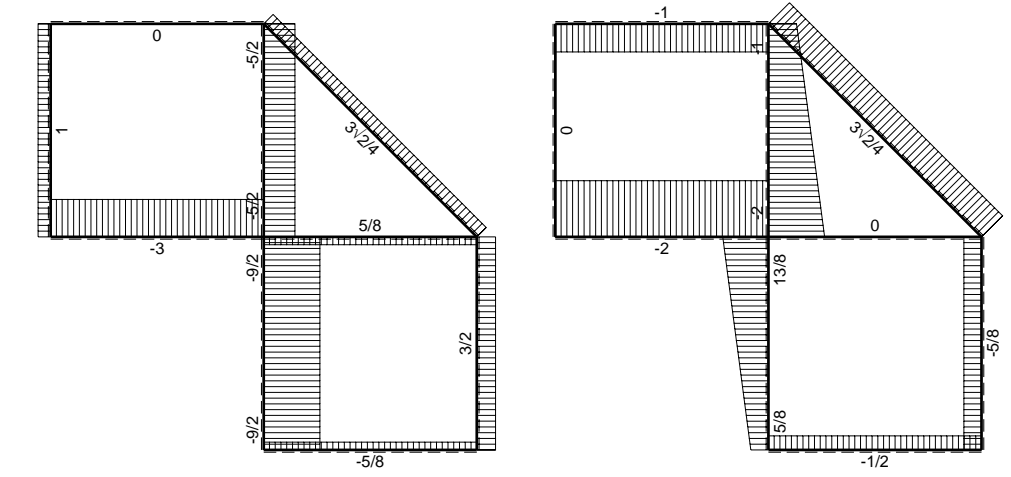
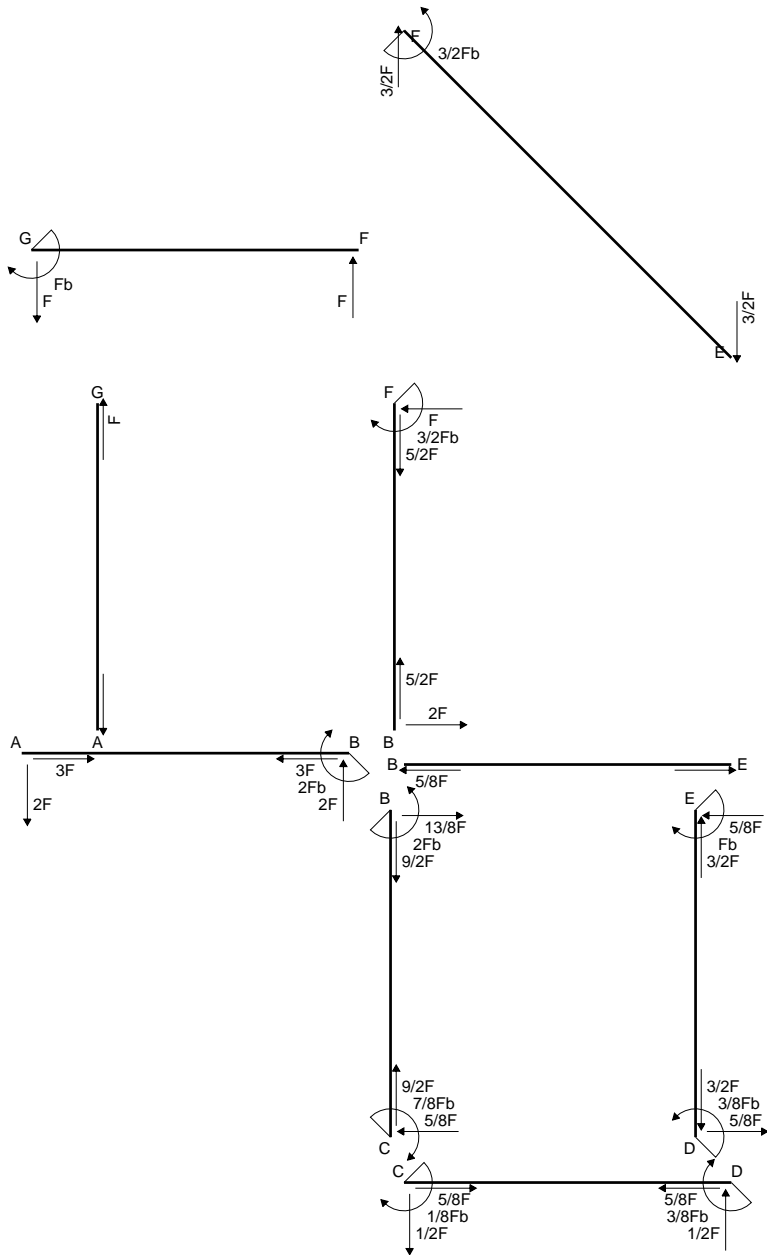

← ⊕ → F

↑ ⊕ ↓ F

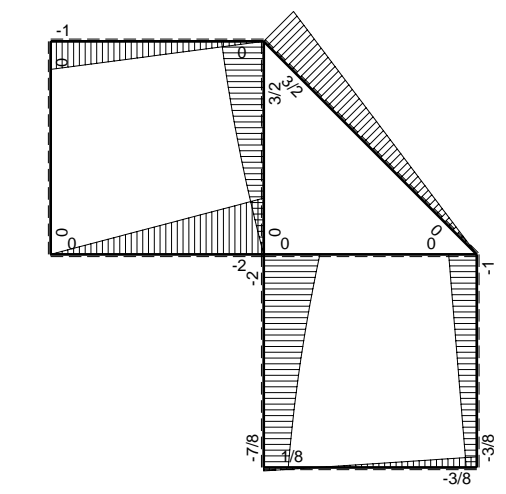

⊕ ⊖ F_b

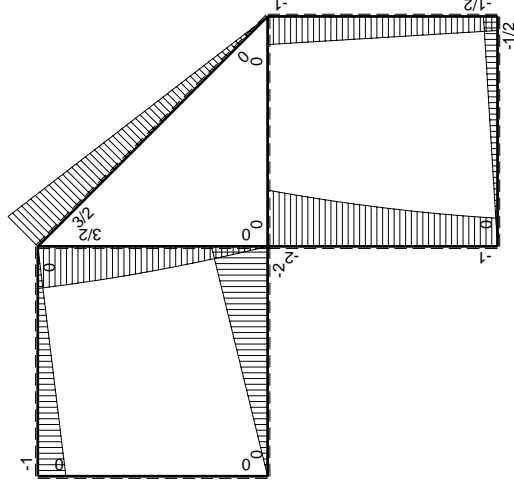
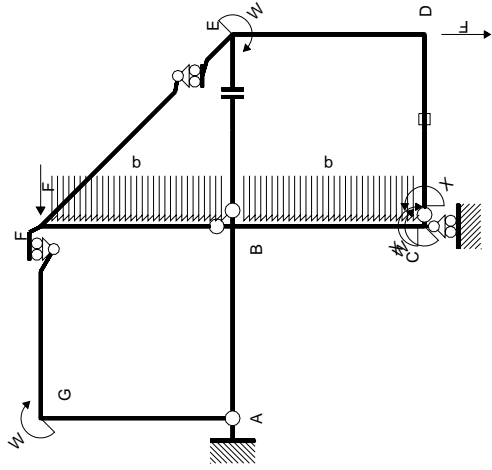

Schema di calcolo iperstatico

M_0 flessione da carichi assegnati

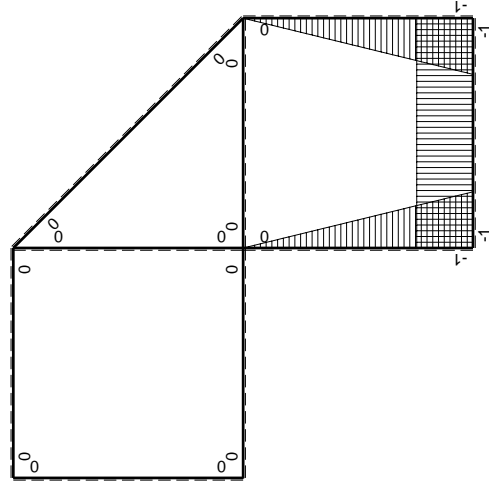

M_x flessione da iperstatica $X=1$

Quadro contribuiti PLV per iperstatica $X=W_{cd}$

\rightarrow	$M_x(x)$	$M_0(x)$	$M_x M_0$	$M_x M_x$	$\int M_x M_0 / EJ dx$	$\int M_x M_x / EJ dx$
AB b	0	-2Fx	0	0	0	0
BA b	0	2Fb-2Fx	0	0	0	0
BC b	-x/b	$-2Fb+3/2Fx-1/2qx^2$	$2Fx-3/2Fx^2/b+1/2qx^3/b$	x^2/b^2	$5/8Fb^2/EJ$	$1/3Xb/EJ$
CB b	1-x/b	$Fb+1/2Fx+1/2qx^2$	$Fb-1/2Fx-1/2qx^3/b$	$1-2x/b+x^2/b^2$	$1/4Fb^2/EJ$	Xb/EJ
CD b	-1	-1/2Fx	1/2Fx	1	$1/4Fb^2/EJ$	Xb/EJ
DC b	1	1/2Fb-1/2Fx	1/2Fb-1/2Fx	1	$1/4Fb^2/EJ$	Xb/EJ
DE b	-1+x/b	-1/2Fb-1/2Fx	$1/2Fb-1/2Fx^2/b$	$1-2x/b+x^2/b^2$	$1/3Fb^2/EJ$	$1/3Xb/EJ$
ED b	x/b	Fb-1/2Fx	$Fx-1/2Fx^2/b$	x^2/b^2	$1/3Fb^2/EJ$	$1/3Xb/EJ$
EF $\sqrt{2}b$	0	$3\sqrt{2}/4Fx$	0	0	0	0
FG b	0	-Fx	0	0	0	0
GF b	0	Fb-Fx	0	0	0	0
GA b	0	0	0	0	0	0
AG b	0	0	0	0	0	0
FB b	0	$3/2Fb-Fx-1/2qx^2$	0	0	0	0
BF b	0	$-2Fx+1/2qx^2$	0	0	0	0
BE b	0	0	0	0	0	0
EB b	0	0	0	0	0	0
CD	elongazione asta $N_{1,cd} \epsilon_{cd} L_{cd}$				$-Fb^2/EJ$	
	totali				$5/24Fb^2/EJ$	$5/3Xb/EJ$
	iperstatica $X=W_{cd}$				$-1/8Fb$	

Sviluppi di calcolo iperstatica

$$L_{BC}^{xx} = \int_0^b (x^2/b^2) 1/EJ dx = [1/3 x^3/b^2]_0^b 1/EJ$$

$$= (1/3 b) 1/EJ = 1/3 b/EJ$$

$$L_{CB}^{xx} = \int_0^b (1 - 2x/b + x^2/b^2) 1/EJ dx = [x - x^2/b + 1/3 x^3/b^2]_0^b 1/EJ$$

$$= (b - b + 1/3 b) 1/EJ = 1/3 b/EJ$$

$$L_{CD}^{xx} = \int_0^b (1) 1/EJ dx = [x]_0^b 1/EJ$$

$$= (b) 1/EJ = b/EJ$$

$$L_{DC}^{xx} = \int_0^b (1) 1/EJ dx = [x]_0^b 1/EJ$$

$$= (b) 1/EJ = b/EJ$$

$$L_{DE}^{xx} = \int_0^b (1 - 2x/b + x^2/b^2) 1/EJ dx = [x - x^2/b + 1/3 x^3/b^2]_0^b 1/EJ$$

$$= (b - b + 1/3 b) 1/EJ = 1/3 b/EJ$$

$$L_{ED}^{xx} = \int_0^b (x^2/b^2) 1/EJ dx = [1/3 x^3/b^2]_0^b 1/EJ$$

$$= (1/3 b) 1/EJ = 1/3 b/EJ$$

$$L_{BC}^{xo} = \int_0^b (2x/b - 3/2 x^2/b^2 + 1/2 x^3/b^3) Fb 1/EJ dx = [x^2/b - 1/2 x^3/b^2 + 1/8 x^4/b^3]_0^b Fb 1/EJ$$

$$= (b - 1/2 b + 1/8 b) Fb 1/EJ = 5/8 Fb^2/EJ$$

$$L_{CB}^{xo} = \int_0^b (1 - 1/2 x/b - 1/2 x^3/b^3) Fb 1/EJ dx = [x - 1/4 x^2/b - 1/8 x^4/b^3]_0^b Fb 1/EJ$$

$$= (b - 1/4 b - 1/8 b) Fb 1/EJ = 5/8 Fb^2/EJ$$

$$L_{CD}^{xo} = \int_0^b (1/2 x/b) Fb 1/EJ dx + 1 (-1) 1 Fb^2/EJ = [1/4 x^2/b]_0^b Fb 1/EJ + 1 (-1) 1 Fb^2/EJ$$

$$= (1/4 b) Fb 1/EJ + 1 (-1) 1 Fb^2/EJ = -3/4 Fb^2/EJ$$

$$L_{DC}^{xo} = \int_0^b (1/2 - 1/2 x/b) Fb 1/EJ dx + 1 (-1) 1 Fb^2/EJ = [1/2 x - 1/4 x^2/b]_0^b Fb 1/EJ + 1 (-1) 1 Fb^2/EJ$$

$$= (1/2 b - 1/4 b) Fb 1/EJ + 1 (-1) 1 Fb^2/EJ = -3/4 Fb^2/EJ$$

$$L_{DE}^{xo} = \int_0^b (1/2 - 1/2 x^2/b^2) Fb 1/EJ dx = [1/2 x - 1/6 x^3/b^2]_0^b Fb 1/EJ$$

$$= (1/2 b - 1/6 b) Fb 1/EJ = 1/3 Fb^2/EJ$$

$$L_{ED}^{xo} = \int_0^b (x/b - 1/2 x^2/b^2) Fb 1/EJ dx = [1/2 x^2/b - 1/6 x^3/b^2]_0^b Fb 1/EJ$$

$$= (1/2 b - 1/6 b) Fb 1/EJ = 1/3 Fb^2/EJ$$

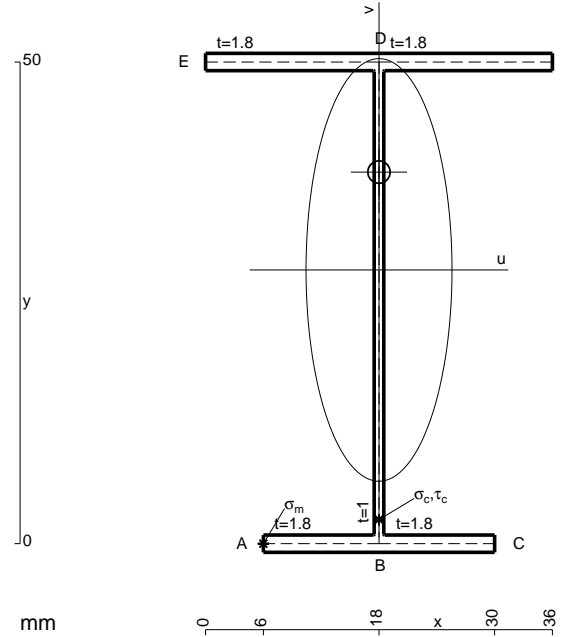

- A = 158. mm²
- J_u = 76071. mm⁴
- J_v = 9072. mm⁴
- J_I = 133.3 mm⁴
- y_o = 10.15 mm
- y_g = 28.42 mm
- N = -1560. N
- T_y = -1040. N
- M_x = -530400. Nmm
- x_m = 6. mm
- u_m = -12. mm
- v_m = -28.42 mm
- σ_m = N/A - Mv/J_u = -208. N/mm²
- x_c = 18. mm
- v_c = -28.42 mm
- σ_c = N/A - Mv/J_u = -208. N/mm²
- τ_c = TS_v/tJ_u = 16.78 N/mm²
- τ_g = TS_v/tJ_u = 16.78 N/mm²
- t_c = 520. mm
- σ_o = √(σ² + 3τ²) = 210. N/mm²

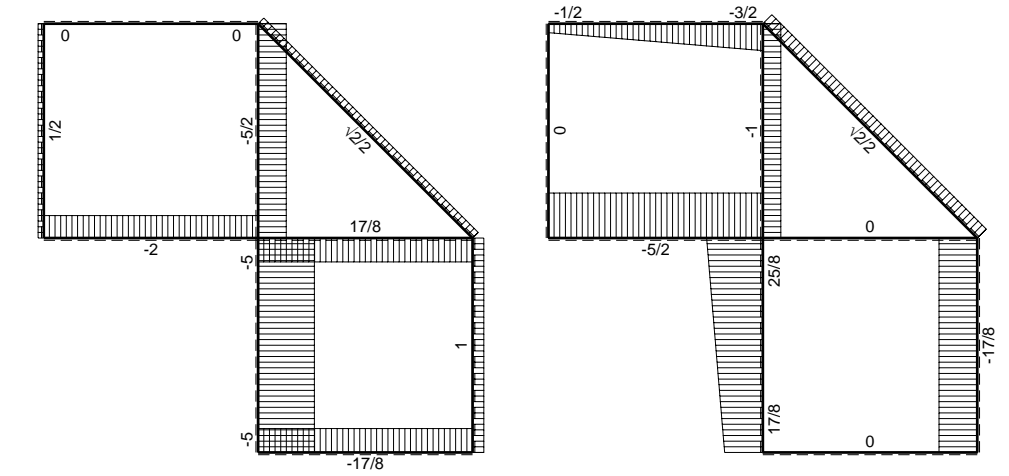
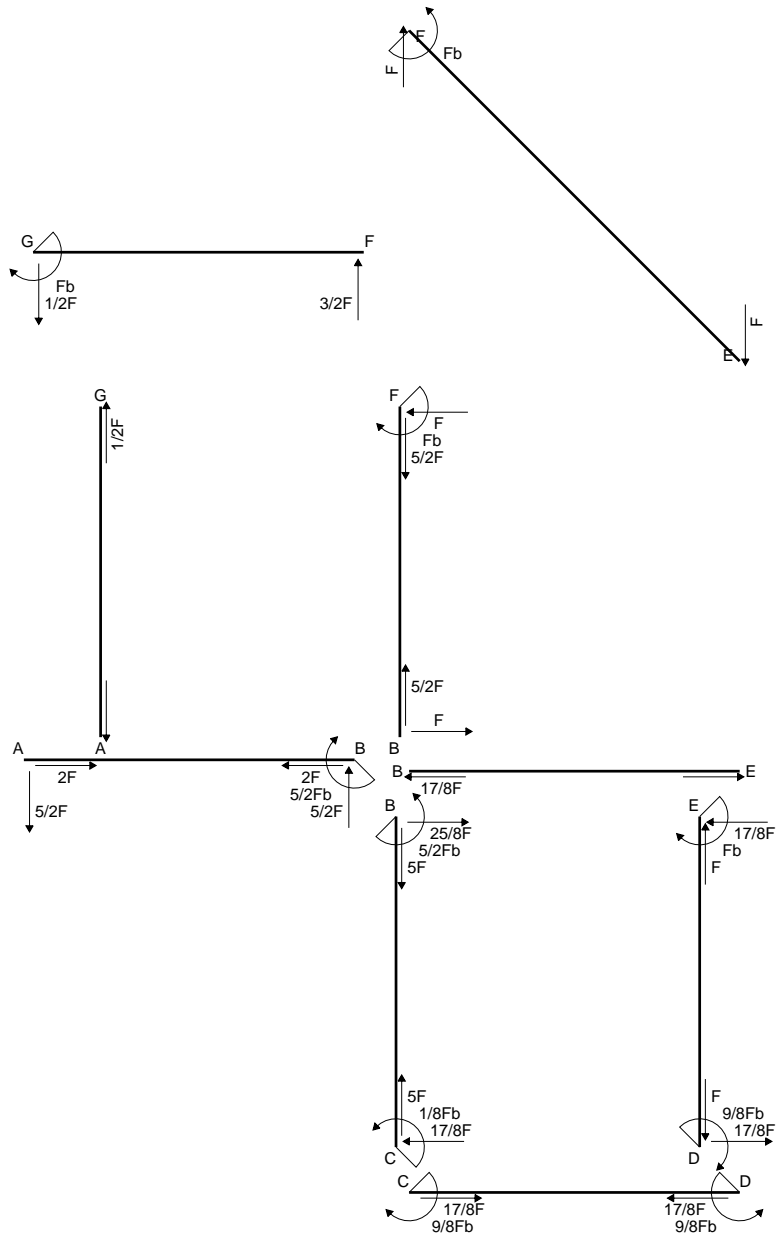

← ⊕ → F

↑ ⊕ ↓ F

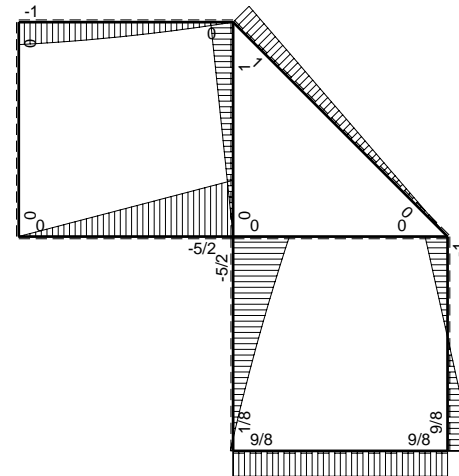

⊕ ⊖ F_b

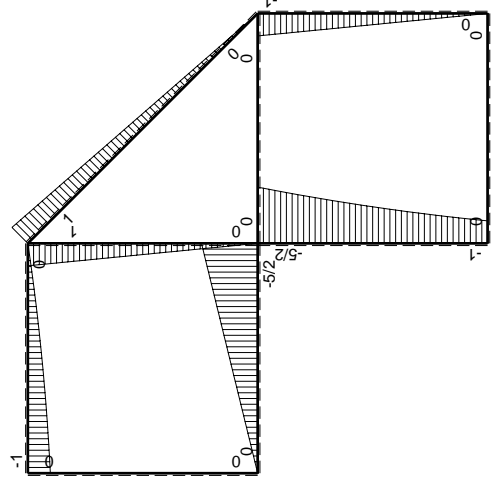
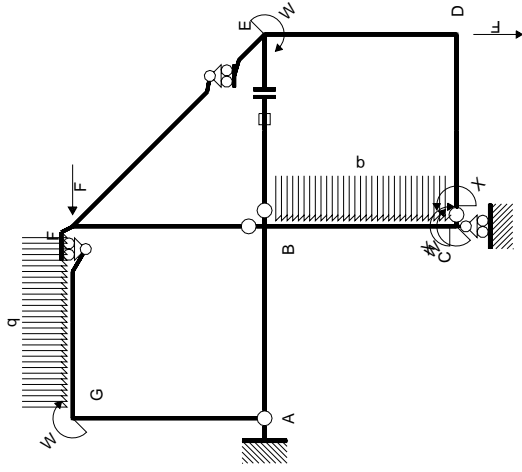

Schema di calcolo iperstatico

M_0 flessione da carichi assegnati

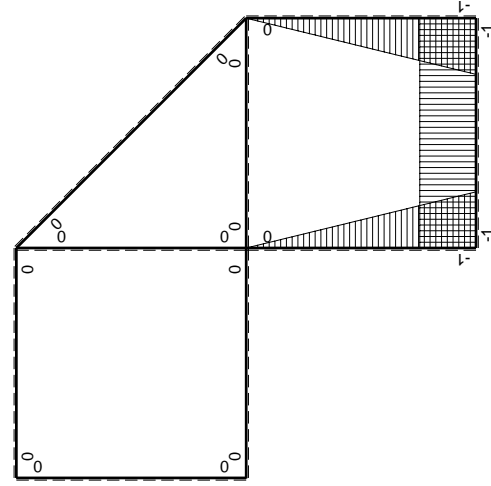

M_x flessione da iperstatica X=1

Quadro contributi PLV per iperstatica X=W_{cd}

→	$M_x(x)$	$M_0(x)$	$M_x M_0$	$M_x M_x$	$\int M_x M_0 / E J dx$	$\int X M_x M_x / E J dx$
AB b	0	-5/2Fx	0	0	0	0
BA b	0	5/2Fb-5/2Fx	0	0	0	0
BC b	-x/b	-5/2Fb+2Fx-1/2qx ²	5/2Fx-2Fx ² /b+1/2qx ³ /b	x ² /b ²	17/24Fb ² /EJ	1/3Xb/EJ
CB b	1-x/b	Fb+Fx+1/2qx ²	Fb-1/2Fx ² /b-1/2qx ³ /b	1-2x/b+x ² /b ²	0	Xb/EJ
CD b	-1	0	0	1	0	0
DC b	1	0	0	1	0	0
DE b	-1+x/b	-Fx	Fx-Fx ² /b	1-2x/b+x ² /b ²	1/6Fb ² /EJ	1/3Xb/EJ
ED b	x/b	Fb-Fx	Fx-Fx ² /b	x ² /b ²	0	0
EF √2b	0	√2/2Fx	0	0	0	0
FG b	0	-3/2Fx+1/2qx ²	0	0	0	0
GF b	0	Fb-1/2Fx-1/2qx ²	0	0	0	0
GA b	0	0	0	0	0	0
AG b	0	0	0	0	0	0
FB b	0	Fb-Fx	0	0	0	0
BF b	0	-Fx	0	0	0	0
BE b	0	0	0	0	0	0
EB b	0	0	0	0	0	0
BE	elongazione asta $N_{1, BE} \epsilon_{BE} L_{BE}$				Fb ² /EJ	
	totali				15/8Fb ² /EJ	5/3Xb/EJ
	iperstatica X=W _{cd}				-9/8Fb	

Sviluppi di calcolo iperstatica

$$L_{BC}^{xx} = \int_0^b (x^2/b^2) 1/EJ dx = [1/3 x^3/b^2]_0^b 1/EJ$$

$$= (1/3 b) 1/EJ = 1/3 b/EJ$$

$$L_{CB}^{xx} = \int_0^b (1 - 2x/b + x^2/b^2) 1/EJ dx = [x - x^2/b + 1/3 x^3/b^2]_0^b 1/EJ$$

$$= (b - b + 1/3 b) 1/EJ = 1/3 b/EJ$$

$$L_{CD}^{xx} = \int_0^b (1) 1/EJ dx = [x]_0^b 1/EJ$$

$$= (b) 1/EJ = b/EJ$$

$$L_{DC}^{xx} = \int_0^b (1) 1/EJ dx = [x]_0^b 1/EJ$$

$$= (b) 1/EJ = b/EJ$$

$$L_{DE}^{xx} = \int_0^b (1 - 2x/b + x^2/b^2) 1/EJ dx = [x - x^2/b + 1/3 x^3/b^2]_0^b 1/EJ$$

$$= (b - b + 1/3 b) 1/EJ = 1/3 b/EJ$$

$$L_{ED}^{xx} = \int_0^b (x^2/b^2) 1/EJ dx = [1/3 x^3/b^2]_0^b 1/EJ$$

$$= (1/3 b) 1/EJ = 1/3 b/EJ$$

$$L_{BC}^{xo} = \int_0^b (5/2 x/b - 2x^2/b^2 + 1/2 x^3/b^3) Fb 1/EJ dx = [5/4 x^2/b - 2/3 x^3/b^2 + 1/8 x^4/b^3]_0^b Fb 1/EJ$$

$$= (5/4 b - 2/3 b + 1/8 b) Fb 1/EJ = 17/24 Fb^2/EJ$$

$$L_{CB}^{xo} = \int_0^b (1 - 1/2 x^2/b^2 - 1/2 x^3/b^3) Fb 1/EJ dx = [x - 1/6 x^3/b^2 - 1/8 x^4/b^3]_0^b Fb 1/EJ$$

$$= (b - 1/6 b - 1/8 b) Fb 1/EJ = 17/24 Fb^2/EJ$$

$$L_{DE}^{xo} = \int_0^b (x/b - x^2/b^2) Fb 1/EJ dx = [1/2 x^2/b - 1/3 x^3/b^2]_0^b Fb 1/EJ$$

$$= (1/2 b - 1/3 b) Fb 1/EJ = 1/6 Fb^2/EJ$$

$$L_{ED}^{xo} = \int_0^b (x/b - x^2/b^2) Fb 1/EJ dx = [1/2 x^2/b - 1/3 x^3/b^2]_0^b Fb 1/EJ$$

$$= (1/2 b - 1/3 b) Fb 1/EJ = 1/6 Fb^2/EJ$$

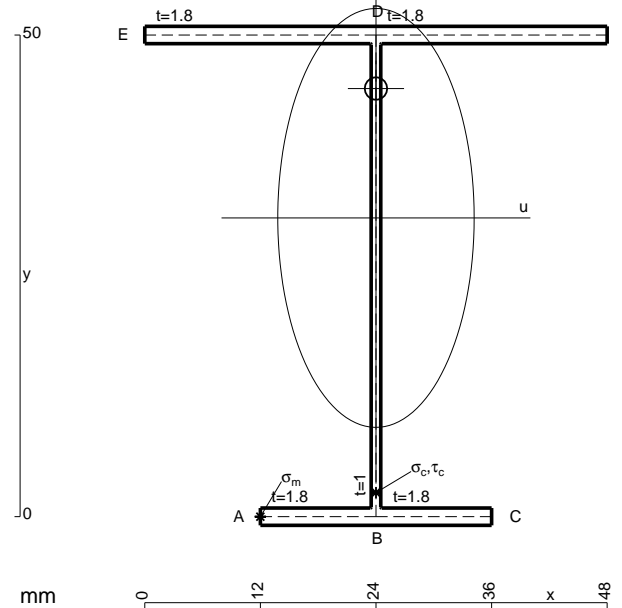

- A = 179.6 mm²
- J_u = 84922. mm⁴
- J_v = 18662. mm⁴
- J_I = 156.6 mm⁴
- y_o = 13.43 mm
- y_g = 31.01 mm
- N = -840. N
- T_y = -1050. N
- M_x = -588000. Nmm
- x_m = 12. mm
- u_m = -12. mm
- v_m = -31.01 mm
- σ_m = N/A-Mv/J_u = -219.4 N/mm²
- x_c = 24. mm
- v_c = -31.01 mm
- σ_c = N/A-Mv/J_u = -219.4 N/mm²
- τ_c = TS^{*}/tJ_u = 16.57 N/mm²
- τ_g = TS^{*}/tJ_u = 16.57 N/mm²
- t_c = 420. mm
- σ_o = √σ²+3τ² = 221.3 N/mm²

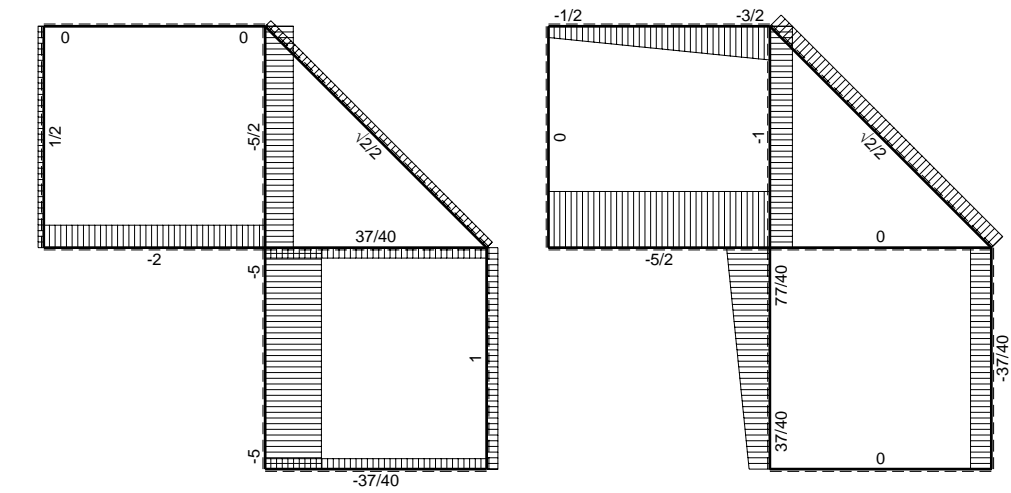
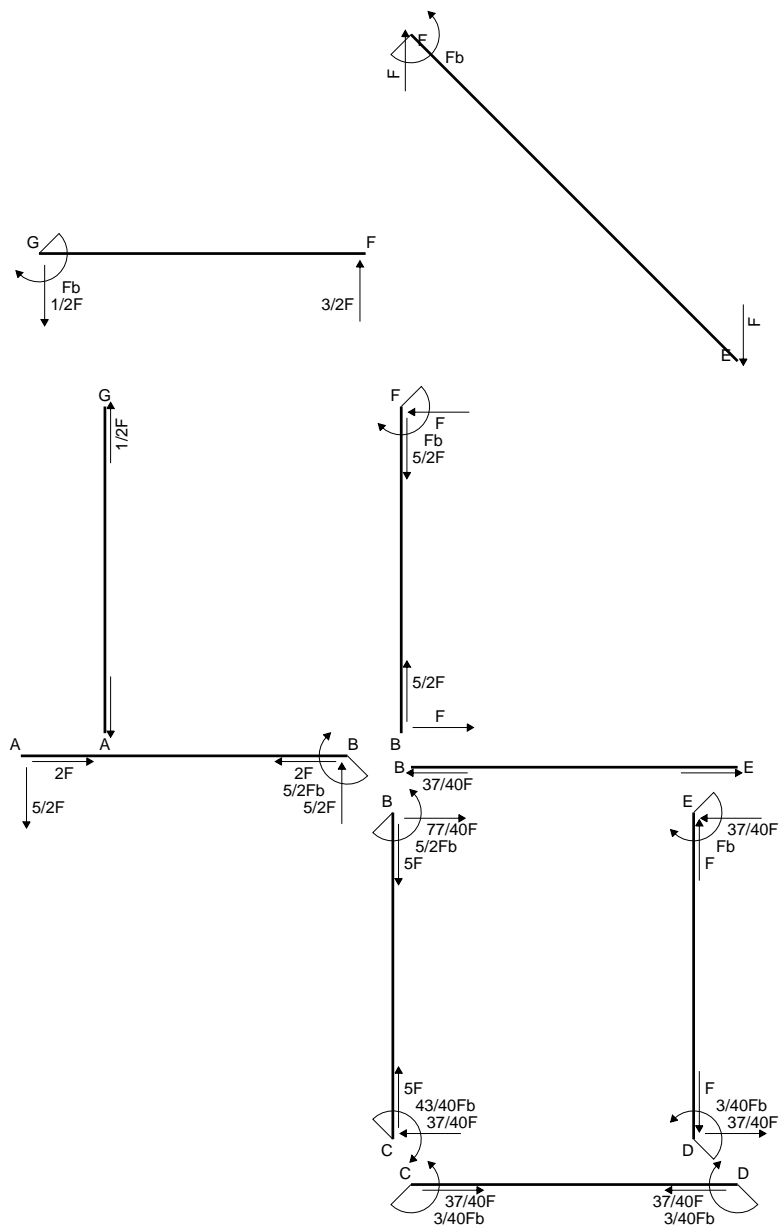

← ⊕ → F

↑ ⊕ ↓ F

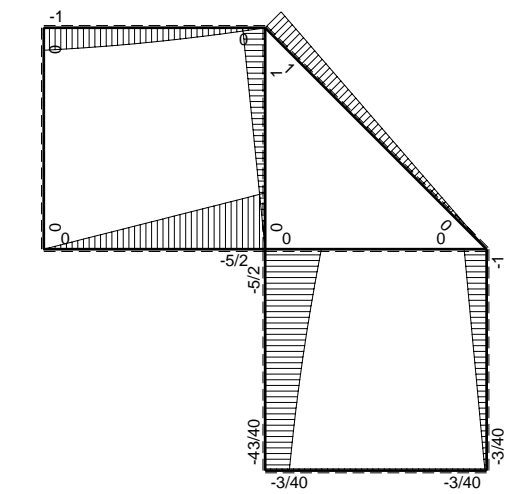

⊕ ⊖ F_b

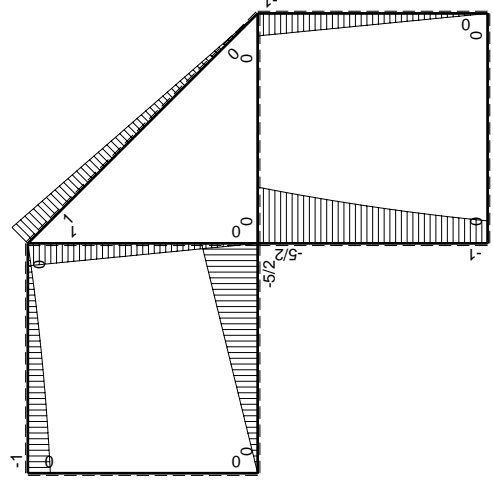
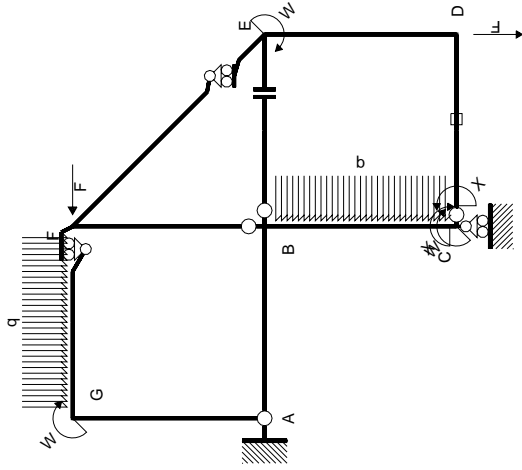

Schema di calcolo iperstatico

M_0 flessione da carichi assegnati

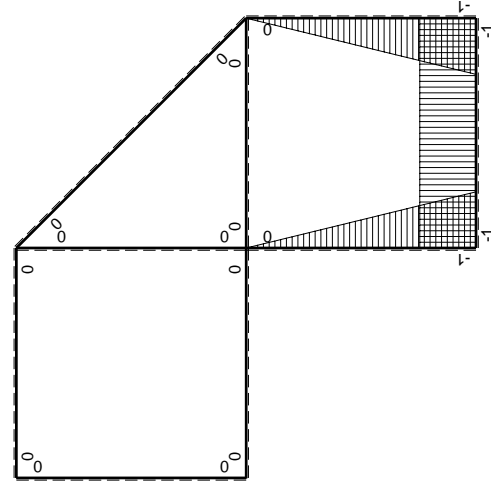

M_x flessione da iperstatica $X=1$

Quadro contribuiti PLV per iperstatica $X=W_{cd}$

\rightarrow	$M_x(x)$	$M_0(x)$	$M_x M_0$	$M_x M_x$	$\int M_x M_0 / E J dx$	$\int M_x M_x / E J dx$
AB b	0	-5/2Fx	0	0	0	0
BA b	0	5/2Fb-5/2Fx	0	0	0	0
BC b	-x/b	-5/2Fb+2Fx-1/2qx ²	5/2Fx-2Fx ² /b+1/2qx ³ /b	x ² /b ²	17/24Fb ² /EJ	1/3Xb/EJ
CB b	1-x/b	Fb+Fx+1/2qx ²	Fb-1/2Fx ² /b-1/2qx ³ /b	1-2x/b+x ² /b ²		
CD b	-1	0	0	1	0	Xb/EJ
DC b	1	0	0	1	0	
DE b	-1+x/b	-Fx	Fx-Fx ² /b	1-2x/b+x ² /b ²	1/6Fb ² /EJ	1/3Xb/EJ
ED b	x/b	Fb-Fx	Fx-Fx ² /b	x ² /b ²		
EF $\sqrt{2}b$	0	$\sqrt{2}/2Fx$	0	0	0	0
FG b	0	-3/2Fx+1/2qx ²	0	0	0	0
GF b	0	Fb-1/2Fx-1/2qx ²	0	0	0	0
GA b	0	0	0	0	0	0
AG b	0	0	0	0	0	0
FB b	0	Fb-Fx	0	0	0	0
BF b	0	-Fx	0	0	0	0
BE b	0	0	0	0	0	0
EB b	0	0	0	0	0	0
CD	elongazione asta $N_{1,cd} \epsilon_{cd} L_{cd}$				-Fb ² /EJ	
	totali				-1/8Fb ² /EJ	5/3Xb/EJ
	iperstatica $X=W_{cd}$				3/40Fb	

Sviluppi di calcolo iperstatica

$$L_{BC}^{xx} = \int_0^b (x^2/b^2) 1/EJ dx = [1/3 x^3/b^2]_0^b 1/EJ$$

$$= (1/3 b) 1/EJ = 1/3 b/EJ$$

$$L_{CB}^{xx} = \int_0^b (1 - 2x/b + x^2/b^2) 1/EJ dx = [x - x^2/b + 1/3 x^3/b^2]_0^b 1/EJ$$

$$= (b - b + 1/3 b) 1/EJ = 1/3 b/EJ$$

$$L_{CD}^{xx} = \int_0^b (1) 1/EJ dx = [x]_0^b 1/EJ$$

$$= (b) 1/EJ = b/EJ$$

$$L_{DC}^{xx} = \int_0^b (1) 1/EJ dx = [x]_0^b 1/EJ$$

$$= (b) 1/EJ = b/EJ$$

$$L_{DE}^{xx} = \int_0^b (1 - 2x/b + x^2/b^2) 1/EJ dx = [x - x^2/b + 1/3 x^3/b^2]_0^b 1/EJ$$

$$= (b - b + 1/3 b) 1/EJ = 1/3 b/EJ$$

$$L_{ED}^{xx} = \int_0^b (x^2/b^2) 1/EJ dx = [1/3 x^3/b^2]_0^b 1/EJ$$

$$= (1/3 b) 1/EJ = 1/3 b/EJ$$

$$L_{BC}^{xo} = \int_0^b (5/2 x/b - 2x^2/b^2 + 1/2 x^3/b^3) Fb 1/EJ dx = [5/4 x^2/b - 2/3 x^3/b^2 + 1/8 x^4/b^3]_0^b Fb 1/EJ$$

$$= (5/4 b - 2/3 b + 1/8 b) Fb 1/EJ = 17/24 Fb^2/EJ$$

$$L_{CB}^{xo} = \int_0^b (1 - 1/2 x^2/b^2 - 1/2 x^3/b^3) Fb 1/EJ dx = [x - 1/6 x^3/b^2 - 1/8 x^4/b^3]_0^b Fb 1/EJ$$

$$= (b - 1/6 b - 1/8 b) Fb 1/EJ = 17/24 Fb^2/EJ$$

$$L_{DE}^{xo} = \int_0^b (x/b - x^2/b^2) Fb 1/EJ dx = [1/2 x^2/b - 1/3 x^3/b^2]_0^b Fb 1/EJ$$

$$= (1/2 b - 1/3 b) Fb 1/EJ = 1/6 Fb^2/EJ$$

$$L_{ED}^{xo} = \int_0^b (x/b - x^2/b^2) Fb 1/EJ dx = [1/2 x^2/b - 1/3 x^3/b^2]_0^b Fb 1/EJ$$

$$= (1/2 b - 1/3 b) Fb 1/EJ = 1/6 Fb^2/EJ$$

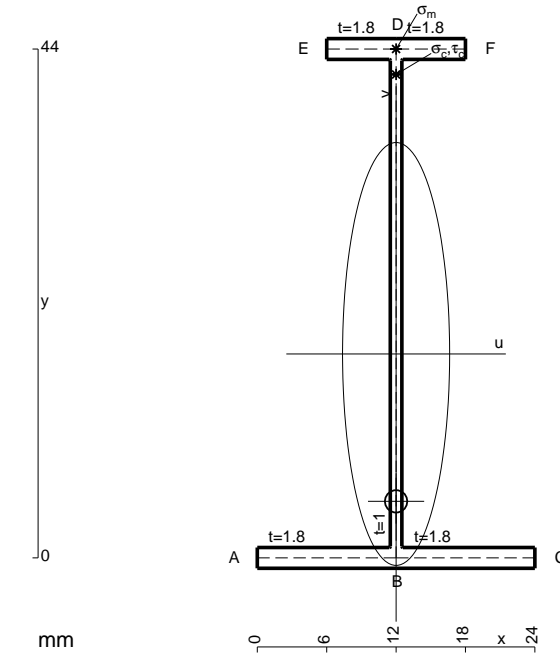

$$A = 108.8 \text{ mm}^2$$

$$J_u = 36386. \text{ mm}^4$$

$$J_v = 2333. \text{ mm}^4$$

$$J_t = 84.65 \text{ mm}^4$$

$$y_o = -12.74 \text{ mm}$$

$$y_g = 17.63 \text{ mm}$$

$$N = -460. \text{ N}$$

$$T_y = -575. \text{ N}$$

$$M_x = -310500. \text{ Nmm}$$

$$x_m = 12. \text{ mm}$$

$$y_m = 44. \text{ mm}$$

$$v_m = 26.37 \text{ mm}$$

$$\sigma_m = N/A - Mv/J_u = 220.8 \text{ N/mm}^2$$

$$y_c = 2. \text{ mm}$$

$$u_c = -12. \text{ mm}$$

$$v_c = -15.63 \text{ mm}$$

$$\sigma_c = N/A - Mv/J_u = 220.8 \text{ N/mm}^2$$

$$\tau_c = TS/tJ_u = 9. \text{ N/mm}^2$$

$$\tau_g = TS/tJ_u = 9. \text{ N/mm}^2$$

$$t_c = 230. \text{ mm}$$

$$\sigma_o = \sqrt{\sigma^2 + 3\tau^2} = 221.3 \text{ N/mm}^2$$

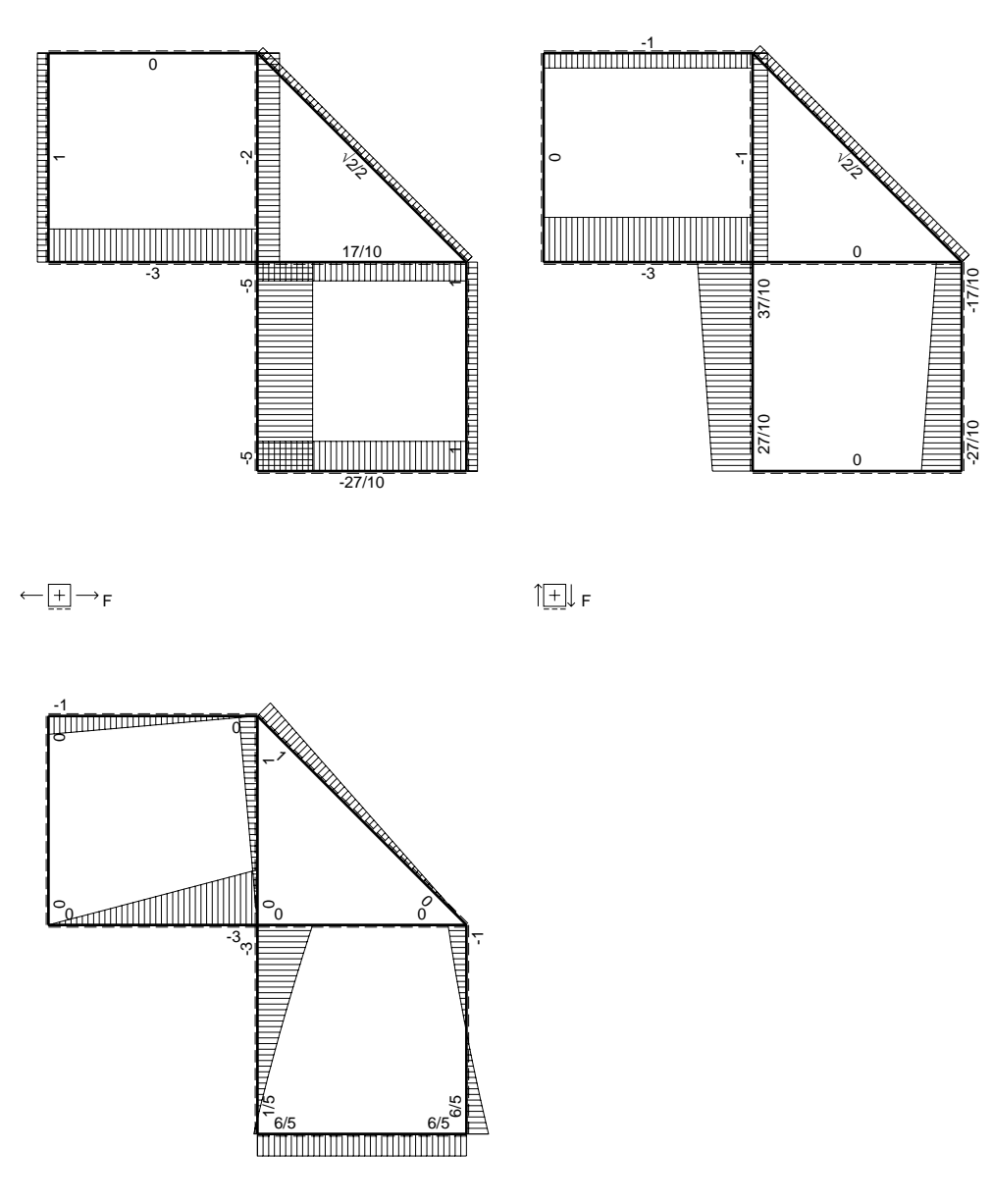
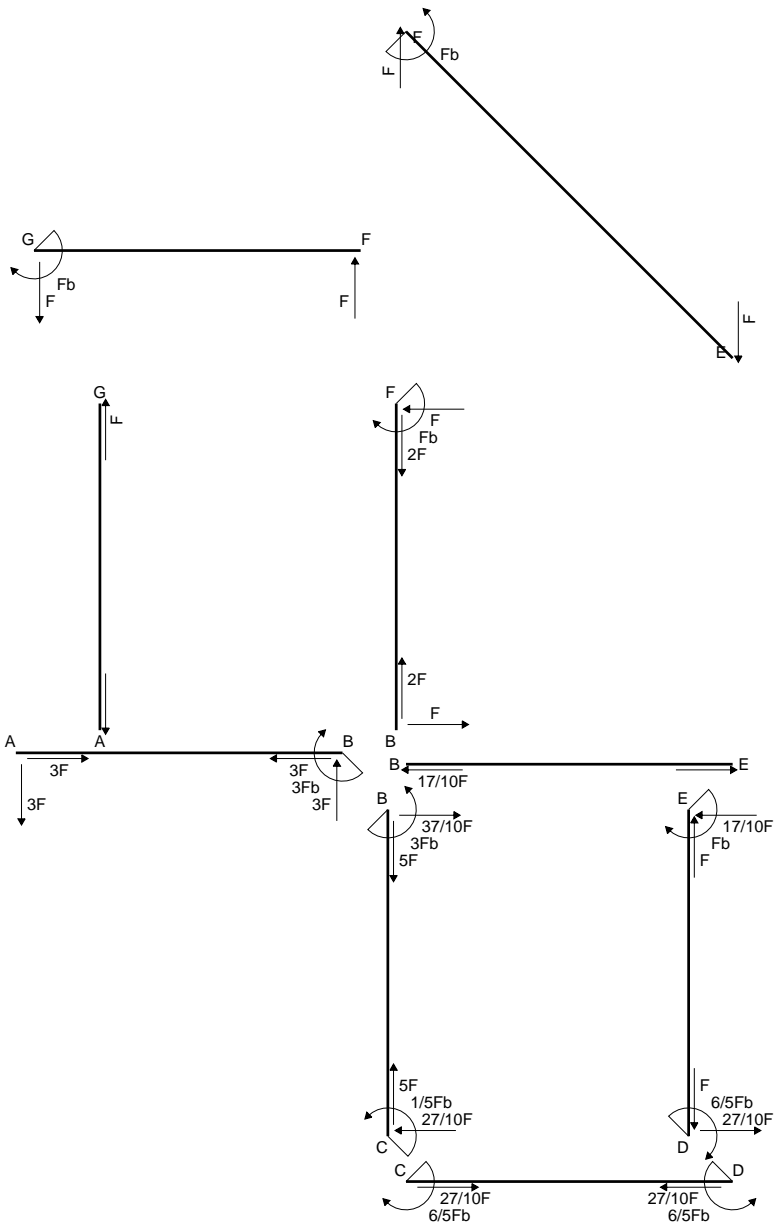

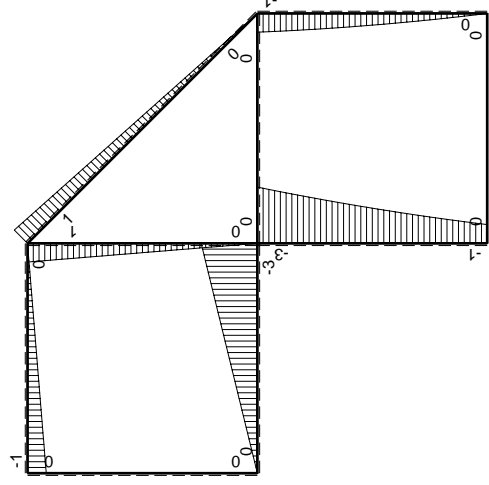
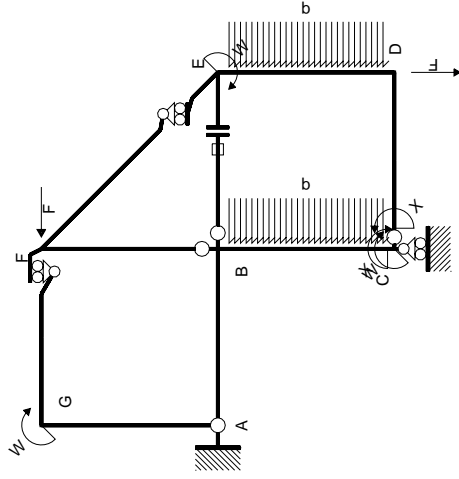

Schema di calcolo iperstatico

M₀ flessione da carichi assegnati

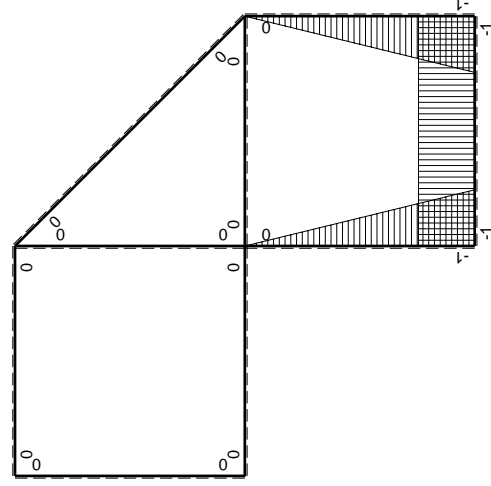

M_x flessione da iperstatica X=1

Quadro contribuiti PLV per iperstatica X=W_{cd}

→	M _x (x)	M ₀ (x)	M _x M ₀	M _x M _x	∫M _x M ₀ /EJdx	∫XM _x M _x /EJdx
AB b	0	-3Fx	0	0	0	0
BA b	0	3Fb-3Fx	0	0	0	0
BC b	-x/b	-3Fb+5/2Fx-1/2qx ²	3/2Fx-5/2Fx ² /b+1/2qx ³ /b	x ² /b ²	19/24Fb ² /EJ	1/3Xb/EJ
CB b	1-x/b	Fb+3/2Fx+1/2qx ²	Fb+1/2Fx-Fx ² /b-1/2qx ³ /b	1-2x/b+x ² /b ²	0	Xb/EJ
CD b	-1	0	0	1	0	0
DC b	1	0	0	1	0	0
DE b	-1+x/b	-3/2Fx+1/2qx ²	3/2Fx-2Fx ² /b+1/2qx ³ /b	1-2x/b+x ² /b ²	5/24Fb ² /EJ	1/3Xb/EJ
ED b	x/b	Fb-1/2Fx-1/2qx ²	Fb-1/2Fx ² /b-1/2qx ³ /b	x ² /b ²	0	0
EF √2b	0	√2/2Fx	0	0	0	0
FG b	0	-Fx	0	0	0	0
GF b	0	Fb-Fx	0	0	0	0
GA b	0	0	0	0	0	0
AG b	0	0	0	0	0	0
FB b	0	Fb-Fx	0	0	0	0
BF b	0	-Fx	0	0	0	0
BE b	0	0	0	0	0	0
EB b	0	0	0	0	0	0
BE	elongazione asta N _{1, BE} ε _{BE} L _{BE}				Fb ² /EJ	
	totali				2Fb ² /EJ	5/3Xb/EJ
	iperstatica X=W _{cd}				-6/5Fb	

Sviluppi di calcolo iperstatica

$$L_{BC}^{xx} = \int_0^b (x^2/b^2) 1/EJ dx = [1/3 x^3/b^2]_0^b 1/EJ$$

$$= (1/3 b) 1/EJ = 1/3 b/EJ$$

$$L_{CB}^{xx} = \int_0^b (1 - 2x/b + x^2/b^2) 1/EJ dx = [x - x^2/b + 1/3 x^3/b^2]_0^b 1/EJ$$

$$= (b - b + 1/3 b) 1/EJ = 1/3 b/EJ$$

$$L_{CD}^{xx} = \int_0^b (1) 1/EJ dx = [x]_0^b 1/EJ$$

$$= (b) 1/EJ = b/EJ$$

$$L_{DC}^{xx} = \int_0^b (1) 1/EJ dx = [x]_0^b 1/EJ$$

$$= (b) 1/EJ = b/EJ$$

$$L_{DE}^{xx} = \int_0^b (1 - 2x/b + x^2/b^2) 1/EJ dx = [x - x^2/b + 1/3 x^3/b^2]_0^b 1/EJ$$

$$= (b - b + 1/3 b) 1/EJ = 1/3 b/EJ$$

$$L_{ED}^{xx} = \int_0^b (x^2/b^2) 1/EJ dx = [1/3 x^3/b^2]_0^b 1/EJ$$

$$= (1/3 b) 1/EJ = 1/3 b/EJ$$

$$L_{BC}^{x_0} = \int_0^b (3x/b - 5/2 x^2/b^2 + 1/2 x^3/b^3) Fb 1/EJ dx = [3/2 x^2/b - 5/6 x^3/b^2 + 1/8 x^4/b^3]_0^b Fb 1/EJ$$

$$= (3/2 b - 5/6 b + 1/8 b) Fb 1/EJ = 19/24 Fb^2/EJ$$

$$L_{CB}^{x_0} = \int_0^b (1 + 1/2 x/b - x^2/b^2 - 1/2 x^3/b^3) Fb 1/EJ dx = [x + 1/4 x^2/b - 1/3 x^3/b^2 - 1/8 x^4/b^3]_0^b Fb 1/EJ$$

$$= (b + 1/4 b - 1/3 b - 1/8 b) Fb 1/EJ = 19/24 Fb^2/EJ$$

$$L_{DE}^{x_0} = \int_0^b (3/2 x/b - 2 x^2/b^2 + 1/2 x^3/b^3) Fb 1/EJ dx = [3/4 x^2/b - 2/3 x^3/b^2 + 1/8 x^4/b^3]_0^b Fb 1/EJ$$

$$= (3/4 b - 2/3 b + 1/8 b) Fb 1/EJ = 5/24 Fb^2/EJ$$

$$L_{ED}^{x_0} = \int_0^b (x/b - 1/2 x^2/b^2 - 1/2 x^3/b^3) Fb 1/EJ dx = [1/2 x^2/b - 1/6 x^3/b^2 - 1/8 x^4/b^3]_0^b Fb 1/EJ$$

$$= (1/2 b - 1/6 b - 1/8 b) Fb 1/EJ = 5/24 Fb^2/EJ$$

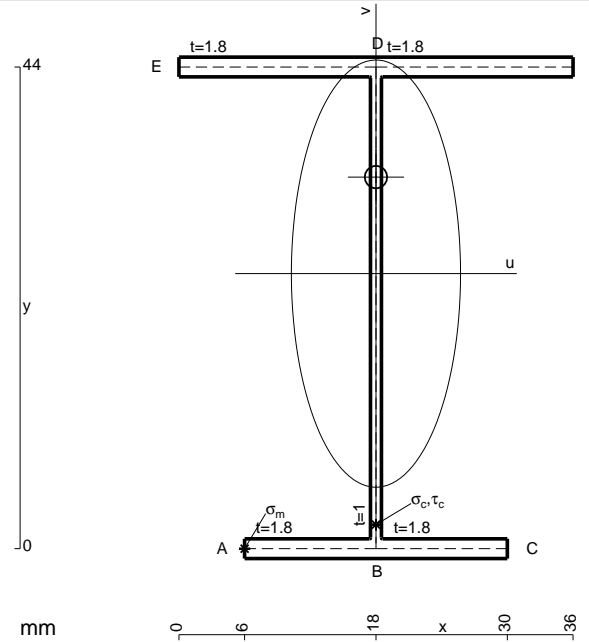

- A = 152. mm²
- J_u = 57885. mm⁴
- J_v = 9072. mm⁴
- J_I = 131.3 mm⁴
- y_o = 8.817 mm
- y_g = 25.13 mm
- N = -900. N
- T_y = -900. N
- M_x = -522000. Nmm
- x_m = 6. mm
- u_m = -12. mm
- v_m = -25.13 mm
- σ_m = N/A-Mv/J_u = -232.5 N/mm²
- x_c = 18. mm
- v_c = -25.13 mm
- σ_c = N/A-Mv/J_u = -232.5 N/mm²
- τ_c = TS³/tJ_u = 16.88 N/mm²
- τ_g = TS³/tJ_u = 16.88 N/mm²
- t_c = 300. mm
- σ_o = √σ²+3τ² = 234.3 N/mm²

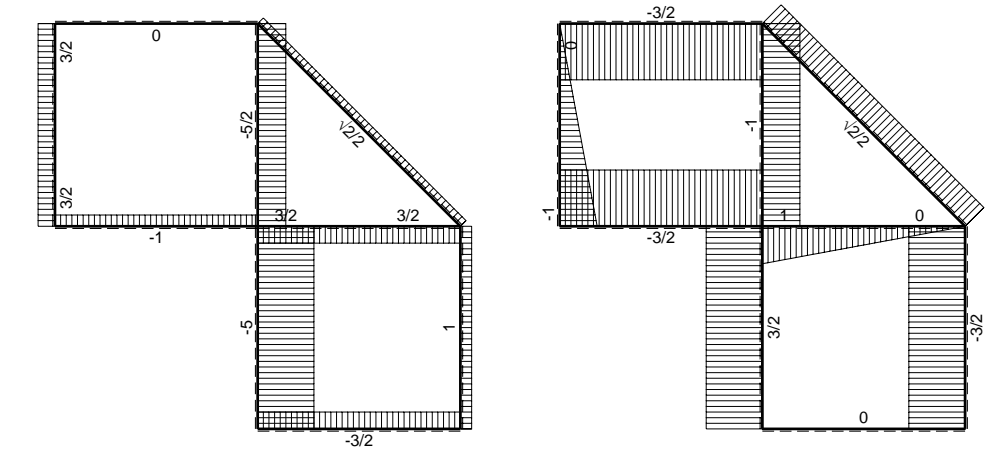
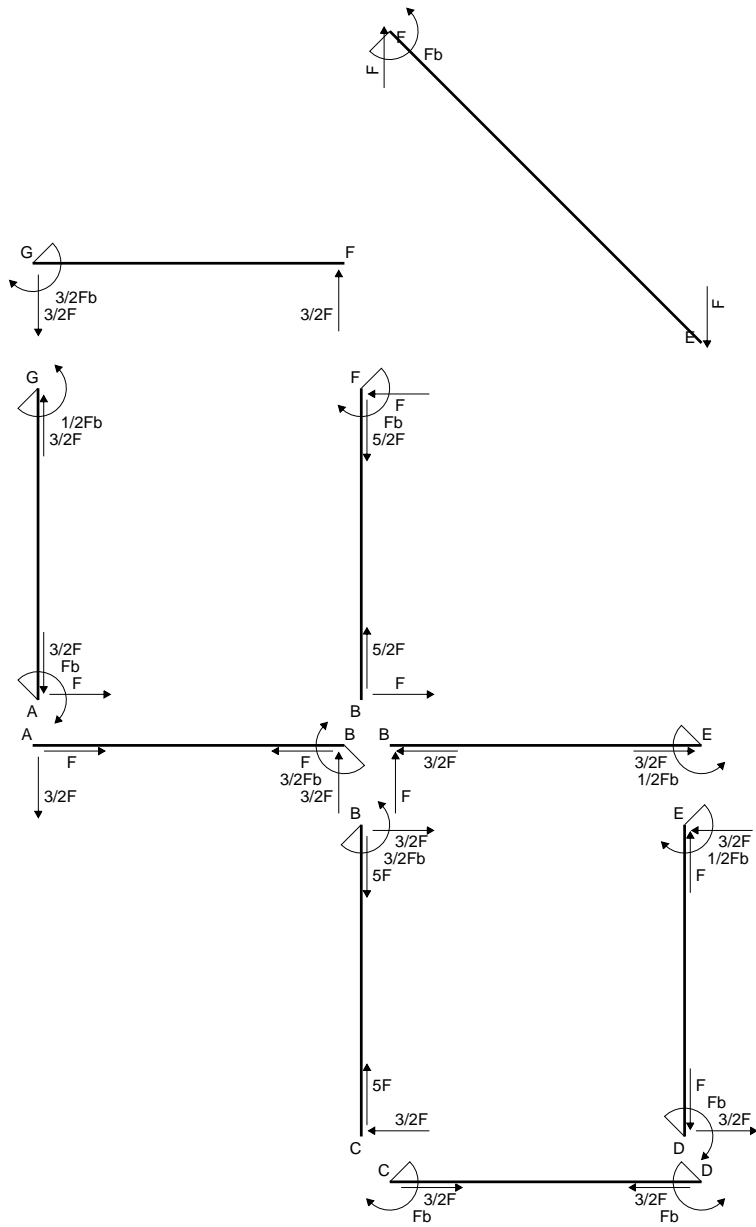

← ⊕ → F

↑ ⊕ ↓ F

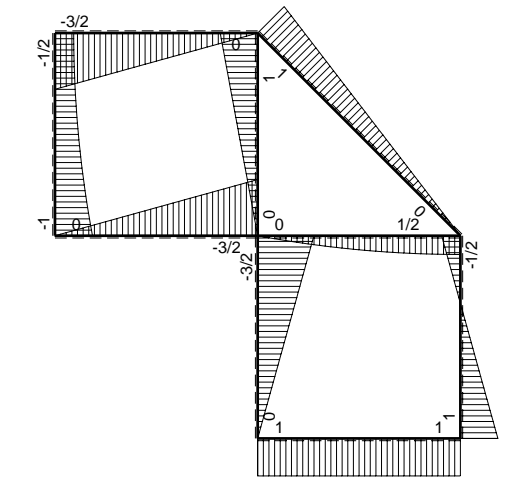

⊕ ⊖ F_b

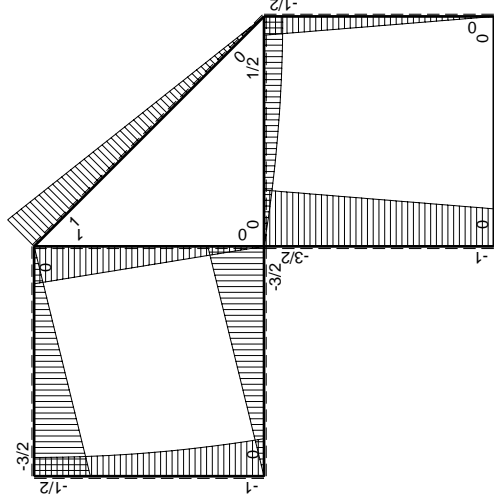
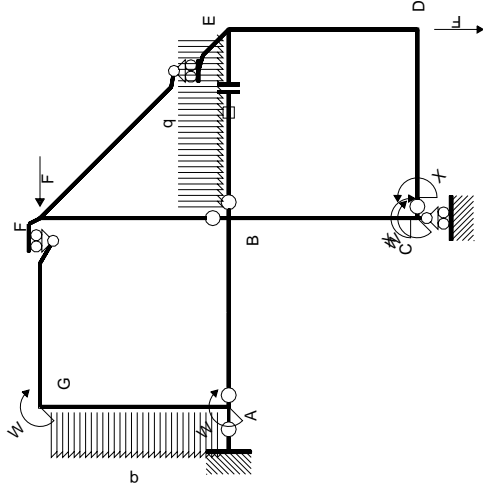

Schema di calcolo iperstatico

M_0 flessione da carichi assegnati

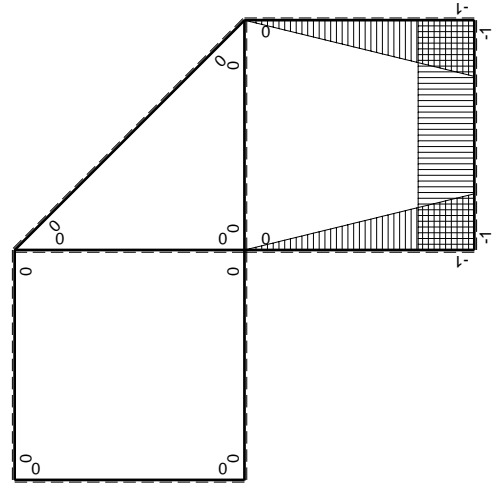

M_x flessione da iperstatica X=1

Quadro contribuiti PLV per iperstatica X=W_{cd}

→	$M_x(x)$	$M_0(x)$	$M_x M_0$	$M_x M_x$	$\int M_x M_0 / EJ dx$	$\int X M_x M_x / EJ dx$
AB b	0	-3/2Fx	0	0	0	0
BA b	0	3/2Fb-3/2Fx	0	0	0	0
BC b	-x/b	-3/2Fb+1/2Fx	3/2Fx-1/2Fx ² /b	x ² /b ²	7/12Fb ² /EJ	1/3Xb/EJ
CB b	1-x/b	Fb+1/2Fx	Fb-1/2Fx-1/2Fx ² /b	1-2x/b+x ² /b ²		
CD b	-1	0	0	1	0	Xb/EJ
DC b	1	0	0	1	0	
DE b	-1+x/b	-1/2Fx	1/2Fx-1/2Fx ² /b	1-2x/b+x ² /b ²	1/12Fb ² /EJ	1/3Xb/EJ
ED b	x/b	1/2Fb-1/2Fx	1/2Fx-1/2Fx ² /b	x ² /b ²		
EF √2b	0	√2/2Fx	0	0	0	0
FG b	0	-3/2Fx	0	0	0	0
GF b	0	3/2Fb-3/2Fx	0	0	0	0
GA b	0	-1/2Fb-1/2qx ²	0	0	0	0
AG b	0	Fb-Fx+1/2qx ²	0	0	0	0
FB b	0	Fb-Fx	0	0	0	0
BF b	0	-Fx	0	0	0	0
BE b	0	Fx-1/2qx ²	0	0	0	0
EB b	0	-1/2Fb+1/2qx ²	0	0	0	0
BE	elongazione asta $N_{1, BE} \epsilon_{BE} = L_{BE}$				Fb ² /EJ	
	totali				5/3Fb ² /EJ	5/3Xb/EJ
	iperstatica X=W _{cd}				-Fb	

Sviluppi di calcolo iperstatica

$$L_{BC}^{xx} = \int_0^b (x^2/b^2) 1/EJ dx = [1/3 x^3/b^2]_0^b 1/EJ$$

$$= (1/3 b) 1/EJ = 1/3 b/EJ$$

$$L_{CB}^{xx} = \int_0^b (1 - 2x/b + x^2/b^2) 1/EJ dx = [x - x^2/b + 1/3 x^3/b^2]_0^b 1/EJ$$

$$= (b - b + 1/3 b) 1/EJ = 1/3 b/EJ$$

$$L_{CD}^{xx} = \int_0^b (1) 1/EJ dx = [x]_0^b 1/EJ$$

$$= (b) 1/EJ = b/EJ$$

$$L_{DC}^{xx} = \int_0^b (1) 1/EJ dx = [x]_0^b 1/EJ$$

$$= (b) 1/EJ = b/EJ$$

$$L_{DE}^{xx} = \int_0^b (1 - 2x/b + x^2/b^2) 1/EJ dx = [x - x^2/b + 1/3 x^3/b^2]_0^b 1/EJ$$

$$= (b - b + 1/3 b) 1/EJ = 1/3 b/EJ$$

$$L_{ED}^{xx} = \int_0^b (x^2/b^2) 1/EJ dx = [1/3 x^3/b^2]_0^b 1/EJ$$

$$= (1/3 b) 1/EJ = 1/3 b/EJ$$

$$L_{BC}^{x_0} = \int_0^b (3/2 x/b - 1/2 x^2/b^2) Fb 1/EJ dx = [3/4 x^2/b - 1/6 x^3/b^2]_0^b Fb 1/EJ$$

$$= (3/4 b - 1/6 b) Fb 1/EJ = 7/12 Fb^2/EJ$$

$$L_{CB}^{x_0} = \int_0^b (1 - 1/2 x/b - 1/2 x^2/b^2) Fb 1/EJ dx = [x - 1/4 x^2/b - 1/6 x^3/b^2]_0^b Fb 1/EJ$$

$$= (b - 1/4 b - 1/6 b) Fb 1/EJ = 7/12 Fb^2/EJ$$

$$L_{DE}^{x_0} = \int_0^b (1/2 x/b - 1/2 x^2/b^2) Fb 1/EJ dx = [1/4 x^2/b - 1/6 x^3/b^2]_0^b Fb 1/EJ$$

$$= (1/4 b - 1/6 b) Fb 1/EJ = 1/12 Fb^2/EJ$$

$$L_{ED}^{x_0} = \int_0^b (1/2 x/b - 1/2 x^2/b^2) Fb 1/EJ dx = [1/4 x^2/b - 1/6 x^3/b^2]_0^b Fb 1/EJ$$

$$= (1/4 b - 1/6 b) Fb 1/EJ = 1/12 Fb^2/EJ$$

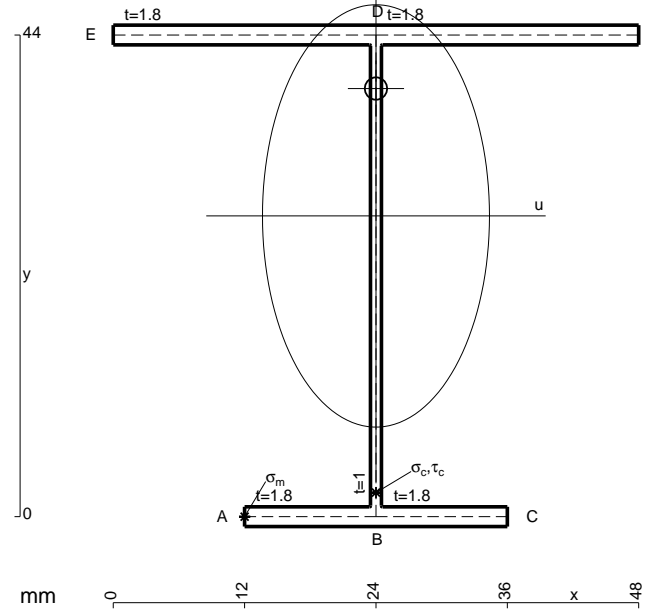

- A = 173.6 mm²
- J_u = 64622. mm⁴
- J_v = 18662. mm⁴
- J_i = 154.6 mm⁴
- y_o = 11.64 mm
- y_g = 27.47 mm
- N = -490. N
- T_y = -735. N
- M_x = -463050. Nmm
- x_m = 12. mm
- u_m = -12. mm
- v_m = -27.47 mm
- σ_m = N/A-Mv/J_u = -199.7 N/mm²
- x_c = 24. mm
- v_c = -27.47 mm
- σ_c = N/A-Mv/J_u = -199.7 N/mm²
- τ_c = TS'/tJ_u = 13.5 N/mm²
- τ_g = TS'/tJ_u = 13.5 N/mm²
- t_c = 490. mm
- σ_o = √σ²+3τ² = 201.1 N/mm²

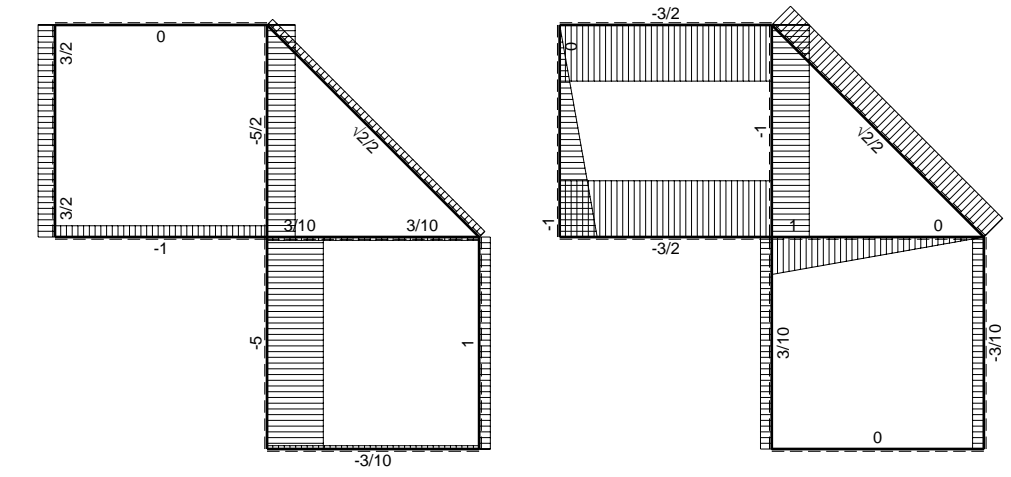
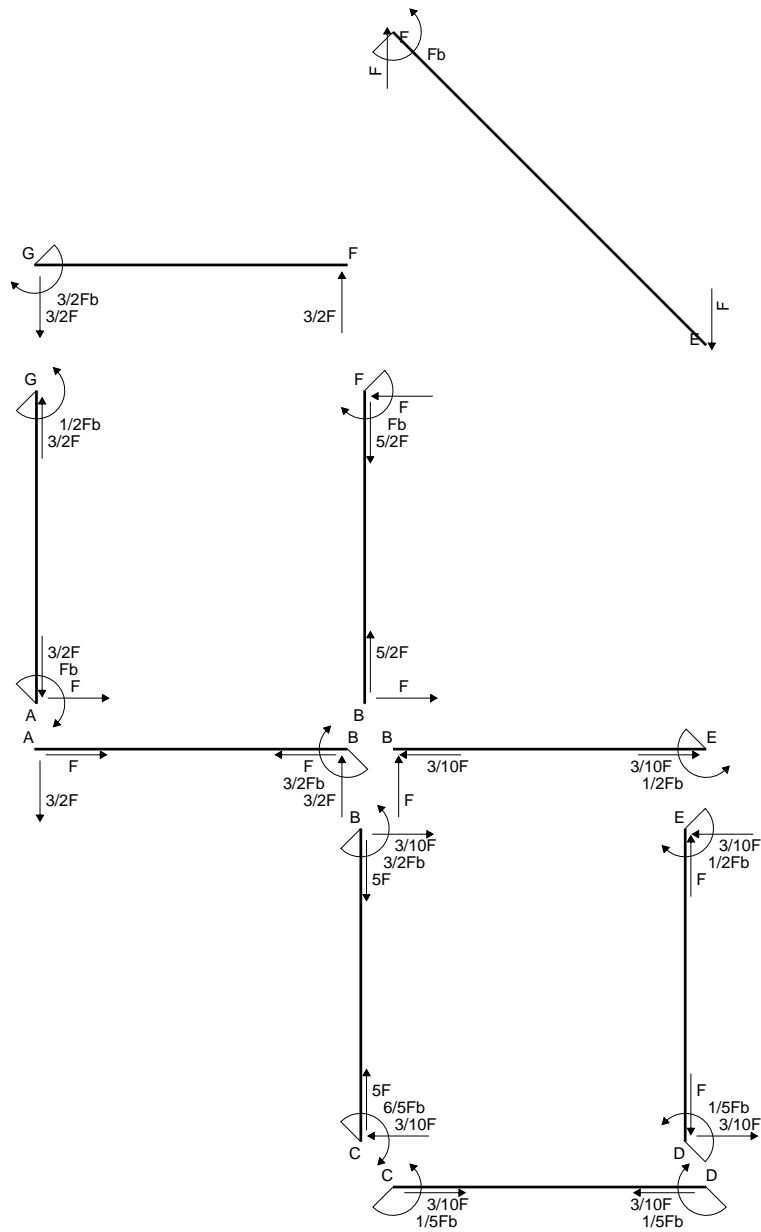

← ⊕ → F

↑ ⊕ ↓ F

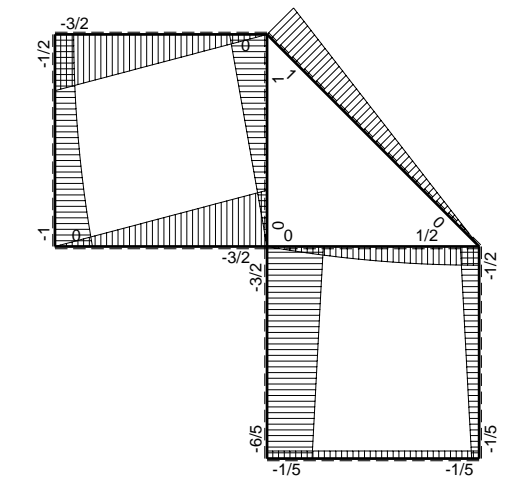

⊕ ⊖ F_b

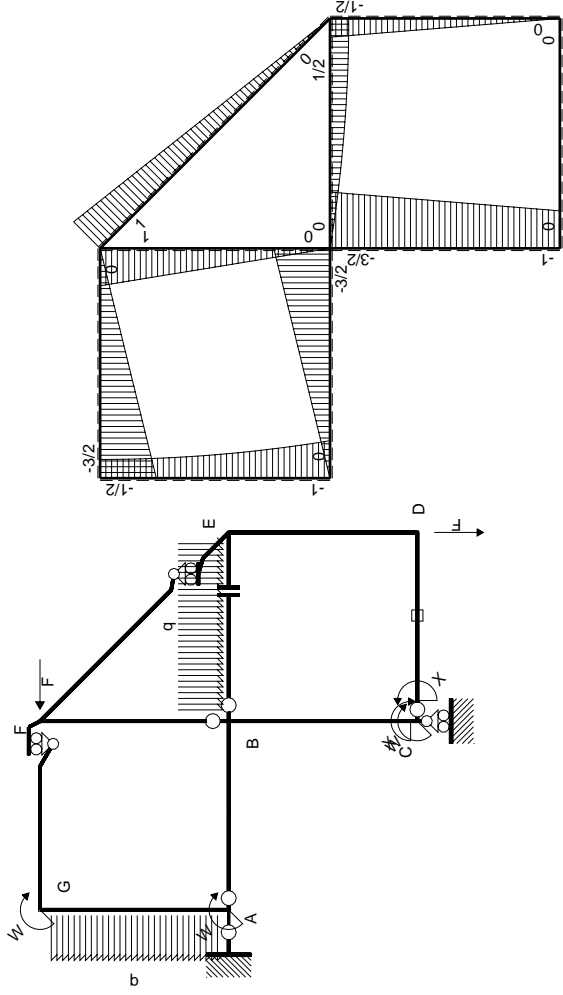

Schema di calcolo iperstatico

M_0 flessione da carichi assegnati

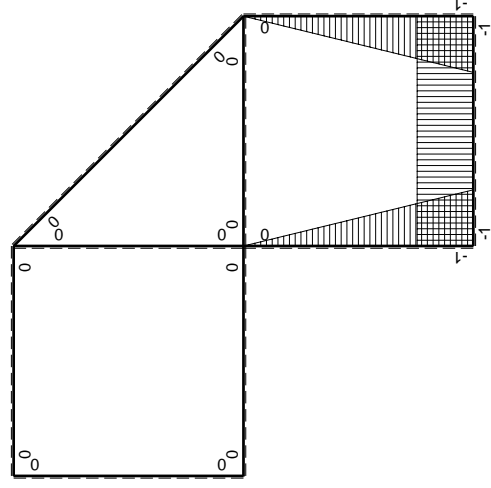

M_x flessione da iperstatica X=1

Quadro contribuiti PLV per iperstatica X=W_{cd}

→	$M_x(x)$	$M_0(x)$	$M_x M_0$	$M_x M_x$	$\int M_x M_0 / EJ dx$	$\int X M_x M_x / EJ dx$
AB b	0	-3/2Fx	0	0	0	0
BA b	0	3/2Fb-3/2Fx	0	0	0	0
BC b	-x/b	-3/2Fb+1/2Fx	3/2Fx-1/2Fx ² /b	x ² /b ²	7/12Fb ² /EJ	1/3Xb/EJ
CB b	1-x/b	Fb+1/2Fx	Fb-1/2Fx-1/2Fx ² /b	1-2x/b+x ² /b ²		
CD b	-1	0	0	1	0	Xb/EJ
DC b	1	0	0	1	0	Xb/EJ
DE b	-1+x/b	-1/2Fx	1/2Fx-1/2Fx ² /b	1-2x/b+x ² /b ²	1/12Fb ² /EJ	1/3Xb/EJ
ED b	x/b	1/2Fb-1/2Fx	1/2Fx-1/2Fx ² /b	x ² /b ²		
EF √2b	0	√2/2Fx	0	0	0	0
FG b	0	-3/2Fx	0	0	0	0
GF b	0	3/2Fb-3/2Fx	0	0	0	0
GA b	0	-1/2Fb-1/2qx ²	0	0	0	0
AG b	0	Fb-Fx+1/2qx ²	0	0	0	0
FB b	0	Fb-Fx	0	0	0	0
BF b	0	-Fx	0	0	0	0
BE b	0	Fx-1/2qx ²	0	0	0	0
EB b	0	-1/2Fb+1/2qx ²	0	0	0	0
CD	elongazione asta $N_{1,cd} \epsilon_{cd} L_{cd}$				-Fb ² /EJ	
	totali				-1/3Fb ² /EJ	5/3Xb/EJ
	iperstatica X=W _{cd}				1/5Fb	

Sviluppi di calcolo iperstatica

$$L_{BC}^{xx} = \int_0^b (x^2/b^2) 1/EJ dx = [1/3 x^3/b^2]_0^b 1/EJ$$

$$= (1/3 b) 1/EJ = 1/3 b/EJ$$

$$L_{CB}^{xx} = \int_0^b (1 - 2x/b + x^2/b^2) 1/EJ dx = [x - x^2/b + 1/3 x^3/b^2]_0^b 1/EJ$$

$$= (b - b + 1/3 b) 1/EJ = 1/3 b/EJ$$

$$L_{CD}^{xx} = \int_0^b (1) 1/EJ dx = [x]_0^b 1/EJ$$

$$= (b) 1/EJ = b/EJ$$

$$L_{DC}^{xx} = \int_0^b (1) 1/EJ dx = [x]_0^b 1/EJ$$

$$= (b) 1/EJ = b/EJ$$

$$L_{DE}^{xx} = \int_0^b (1 - 2x/b + x^2/b^2) 1/EJ dx = [x - x^2/b + 1/3 x^3/b^2]_0^b 1/EJ$$

$$= (b - b + 1/3 b) 1/EJ = 1/3 b/EJ$$

$$L_{ED}^{xx} = \int_0^b (x^2/b^2) 1/EJ dx = [1/3 x^3/b^2]_0^b 1/EJ$$

$$= (1/3 b) 1/EJ = 1/3 b/EJ$$

$$L_{BC}^{x_0} = \int_0^b (3/2 x/b - 1/2 x^2/b^2) Fb 1/EJ dx = [3/4 x^2/b - 1/6 x^3/b^2]_0^b Fb 1/EJ$$

$$= (3/4 b - 1/6 b) Fb 1/EJ = 7/12 Fb^2/EJ$$

$$L_{CB}^{x_0} = \int_0^b (1 - 1/2 x/b - 1/2 x^2/b^2) Fb 1/EJ dx = [x - 1/4 x^2/b - 1/6 x^3/b^2]_0^b Fb 1/EJ$$

$$= (b - 1/4 b - 1/6 b) Fb 1/EJ = 7/12 Fb^2/EJ$$

$$L_{DE}^{x_0} = \int_0^b (1/2 x/b - 1/2 x^2/b^2) Fb 1/EJ dx = [1/4 x^2/b - 1/6 x^3/b^2]_0^b Fb 1/EJ$$

$$= (1/4 b - 1/6 b) Fb 1/EJ = 1/12 Fb^2/EJ$$

$$L_{ED}^{x_0} = \int_0^b (1/2 x/b - 1/2 x^2/b^2) Fb 1/EJ dx = [1/4 x^2/b - 1/6 x^3/b^2]_0^b Fb 1/EJ$$

$$= (1/4 b - 1/6 b) Fb 1/EJ = 1/12 Fb^2/EJ$$

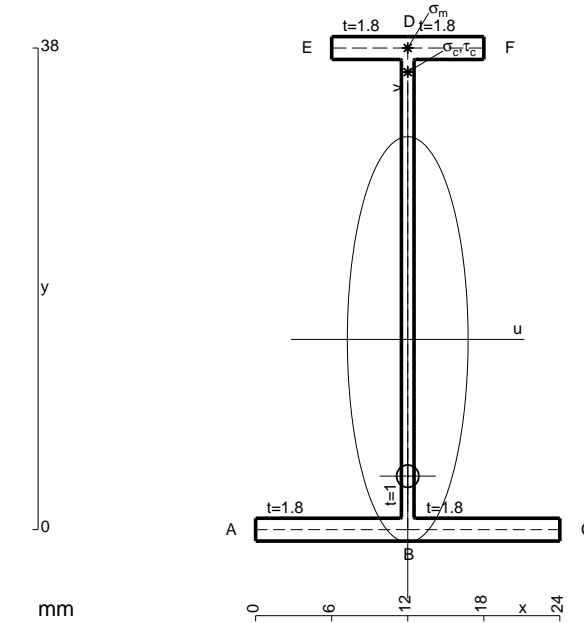

- A = 102.8 mm²
- J_u = 26327. mm⁴
- J_v = 2333. mm⁴
- J_i = 82.65 mm⁴
- y_o = -10.79 mm
- y_g = 15.01 mm
- T_y = -420. N
- M_x = -239400. Nmm
- x_m = 12. mm
- y_m = 38. mm
- v_m = 22.99 mm
- σ_m = -Mv/J_u = 209.1 N/mm²
- y_c = 2. mm
- u_c = -12. mm
- v_c = -13.01 mm
- σ_c = -Mv/J_u = 209.1 N/mm²
- τ_c = TS_y/tJ_u = 7.923 N/mm²
- τ_g = TS_y/tJ_u = 7.923 N/mm²
- t_c = 280. mm
- σ_o = √σ_c² + 3τ_c² = 209.5 N/mm²

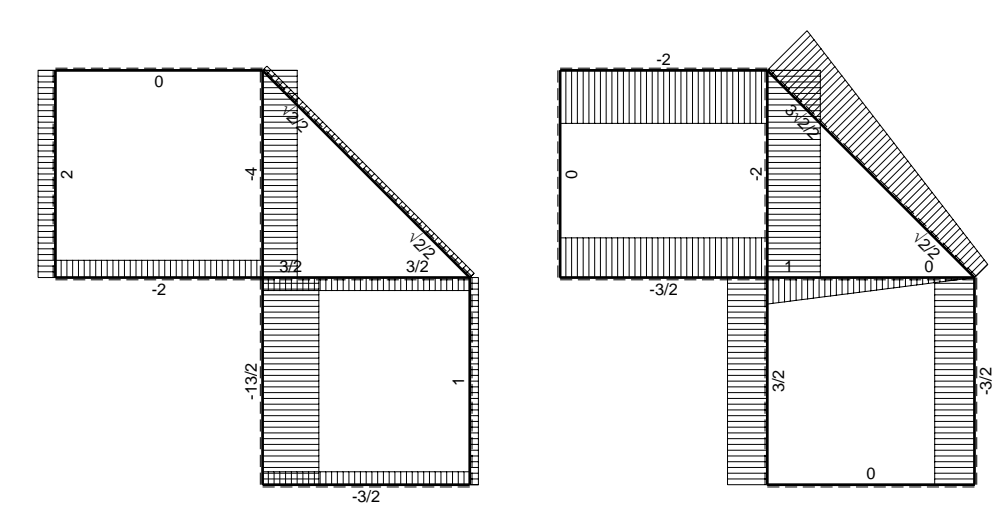
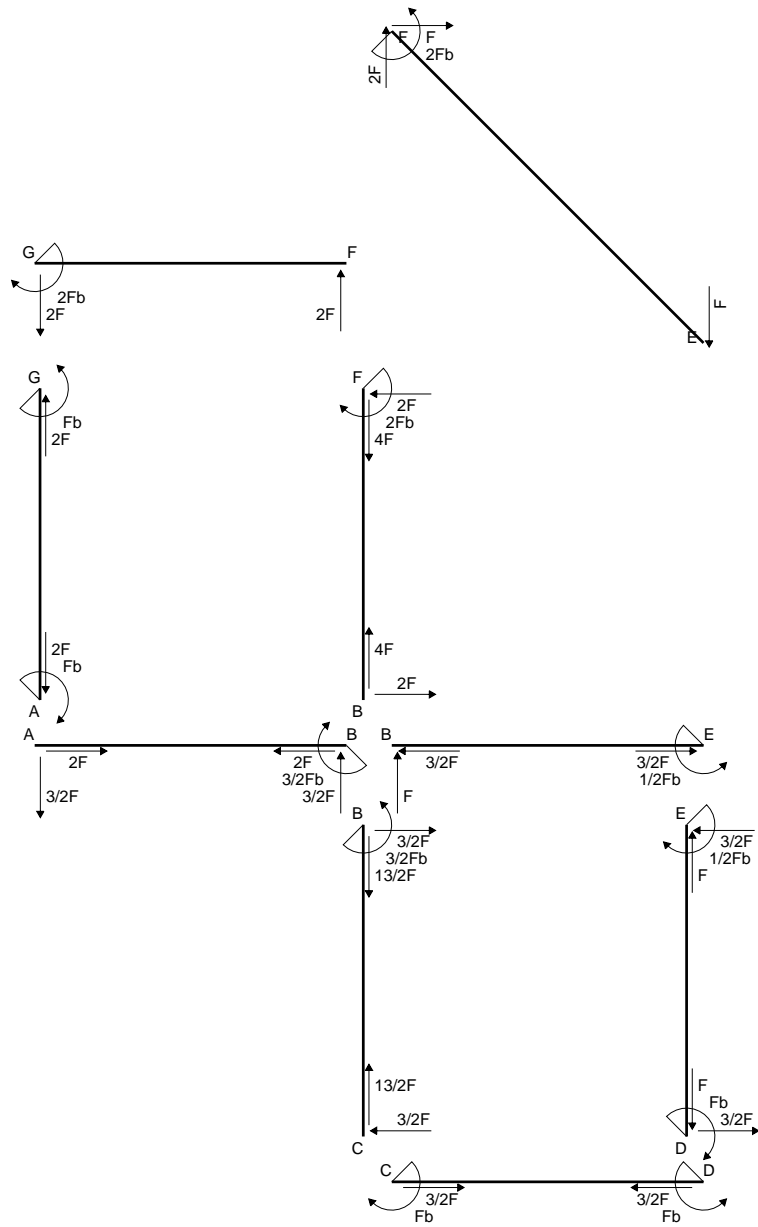

← ⊕ → F

↑ ⊕ ↓ F

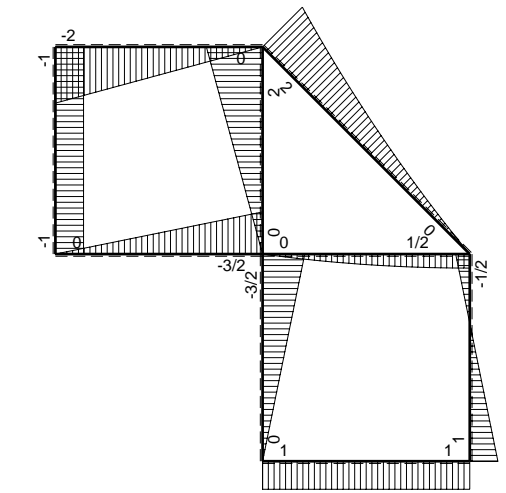

⊕ ⊖ F_b

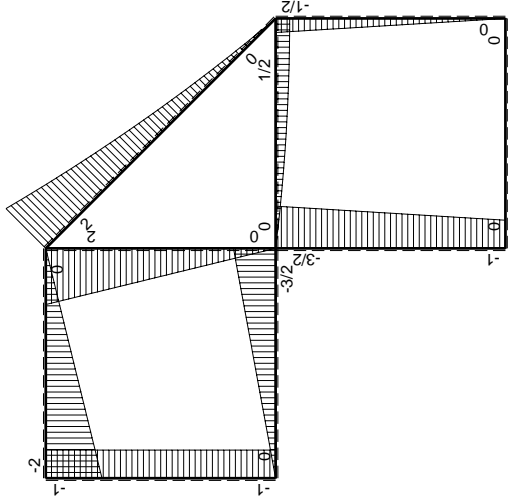
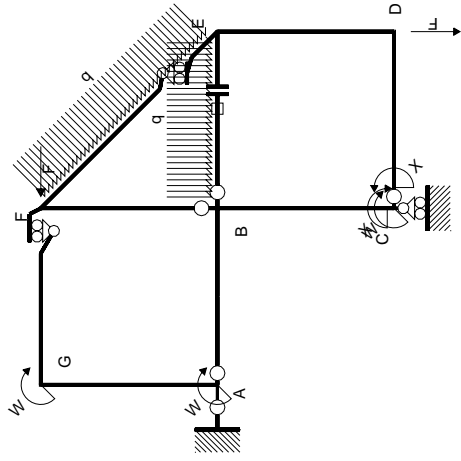

Schema di calcolo iperstatico

(\oplus) M_0 flessione da carichi assegnati

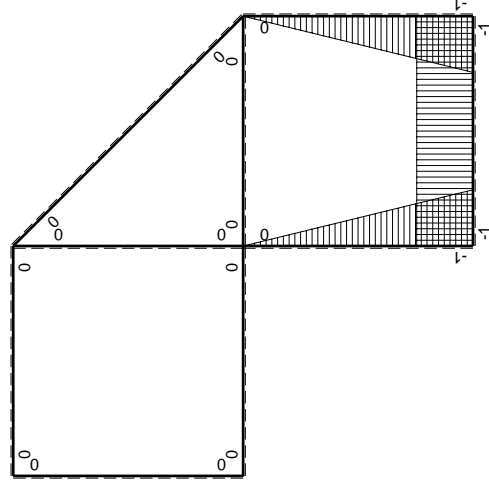

(\oplus) M_x flessione da iperstatica $X=1$

Quadro contribuiti PLV per iperstatica $X=W_{cd}$

\rightarrow	$M_x(x)$	$M_0(x)$	$M_x M_0$	$M_x M_x$	$\int M_x M_0 / E J dx$	$\int X M_x M_x / E J dx$
AB b	0	-3/2Fx	0	0	0	0
BA b	0	3/2Fb-3/2Fx	0	0	0	0
BC b	-x/b	-3/2Fb+1/2Fx	3/2Fx-1/2Fx ² /b	x ² /b ²	7/12Fb ² /EJ	1/3Xb/EJ
CB b	1-x/b	Fb+1/2Fx	Fb-1/2Fx-1/2Fx ² /b	1-2x/b+x ² /b ²		
CD b	-1	0	0	1	0	Xb/EJ
DC b	1	0	0	1	0	
DE b	-1+x/b	-1/2Fx	1/2Fx-1/2Fx ² /b	1-2x/b+x ² /b ²	1/12Fb ² /EJ	1/3Xb/EJ
ED b	x/b	1/2Fb-1/2Fx	1/2Fx-1/2Fx ² /b	x ² /b ²		
EF $\sqrt{2}b$	0	$\sqrt{2}/2Fx+1/2qx^2$	0	0	0	0
FG b	0	-2Fx	0	0	0	0
GF b	0	2Fb-2Fx	0	0	0	0
GA b	0	-Fb	0	0	0	0
AG b	0	Fb	0	0	0	0
FB b	0	2Fb-2Fx	0	0	0	0
BF b	0	-2Fx	0	0	0	0
BE b	0	Fx-1/2qx ²	0	0	0	0
EB b	0	-1/2Fb+1/2qx ²	0	0	0	0
BE	elongazione asta $N_{1, BE} \epsilon_{BE} L_{BE}$				Fb ² /EJ	
	totali				5/3Fb ² /EJ	5/3Xb/EJ
	iperstatica $X=W_{cd}$				-Fb	

Sviluppi di calcolo iperstatica

$$L_{BC}^{xx} = \int_0^b (x^2/b^2) 1/EJ dx = [1/3 x^3/b^2]_0^b 1/EJ$$

$$= (1/3 b) 1/EJ = 1/3 b/EJ$$

$$L_{CB}^{xx} = \int_0^b (1 - 2x/b + x^2/b^2) 1/EJ dx = [x - x^2/b + 1/3 x^3/b^2]_0^b 1/EJ$$

$$= (b - b + 1/3 b) 1/EJ = 1/3 b/EJ$$

$$L_{CD}^{xx} = \int_0^b (1) 1/EJ dx = [x]_0^b 1/EJ$$

$$= (b) 1/EJ = b/EJ$$

$$L_{DC}^{xx} = \int_0^b (1) 1/EJ dx = [x]_0^b 1/EJ$$

$$= (b) 1/EJ = b/EJ$$

$$L_{DE}^{xx} = \int_0^b (1 - 2x/b + x^2/b^2) 1/EJ dx = [x - x^2/b + 1/3 x^3/b^2]_0^b 1/EJ$$

$$= (b - b + 1/3 b) 1/EJ = 1/3 b/EJ$$

$$L_{ED}^{xx} = \int_0^b (x^2/b^2) 1/EJ dx = [1/3 x^3/b^2]_0^b 1/EJ$$

$$= (1/3 b) 1/EJ = 1/3 b/EJ$$

$$L_{BC}^{xo} = \int_0^b (3/2 x/b - 1/2 x^2/b^2) Fb 1/EJ dx = [3/4 x^2/b - 1/6 x^3/b^2]_0^b Fb 1/EJ$$

$$= (3/4 b - 1/6 b) Fb 1/EJ = 7/12 Fb^2/EJ$$

$$L_{CB}^{xo} = \int_0^b (1 - 1/2 x/b - 1/2 x^2/b^2) Fb 1/EJ dx = [x - 1/4 x^2/b - 1/6 x^3/b^2]_0^b Fb 1/EJ$$

$$= (b - 1/4 b - 1/6 b) Fb 1/EJ = 7/12 Fb^2/EJ$$

$$L_{DE}^{xo} = \int_0^b (1/2 x/b - 1/2 x^2/b^2) Fb 1/EJ dx = [1/4 x^2/b - 1/6 x^3/b^2]_0^b Fb 1/EJ$$

$$= (1/4 b - 1/6 b) Fb 1/EJ = 1/12 Fb^2/EJ$$

$$L_{ED}^{xo} = \int_0^b (1/2 x/b - 1/2 x^2/b^2) Fb 1/EJ dx = [1/4 x^2/b - 1/6 x^3/b^2]_0^b Fb 1/EJ$$

$$= (1/4 b - 1/6 b) Fb 1/EJ = 1/12 Fb^2/EJ$$

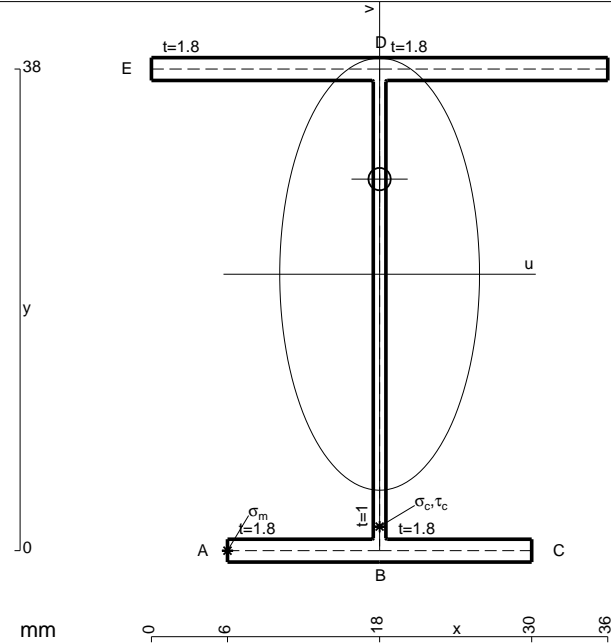

- A = 146. mm²
- J_u = 42407. mm⁴
- J_v = 9072. mm⁴
- J_i = 129.3 mm⁴
- y_o = 7.503 mm
- y_g = 21.81 mm
- N = 240.4 N
- T_y = 721.2 N
- M_x = 414800. Nmm
- x_m = 6. mm
- u_m = -12. mm
- v_m = -21.81 mm
- σ_m = N/A-Mv/J_u = 215. N/mm²
- x_c = 18. mm
- v_c = -21.81 mm
- σ_c = N/A-Mv/J_u = 215. N/mm²
- τ_c = TS_v/tJ_u = 16.03 N/mm²
- τ_g = TS_v/tJ_u = 16.03 N/mm²
- t_c = 340. mm
- σ_o = √σ²+3τ² = 216.8 N/mm²

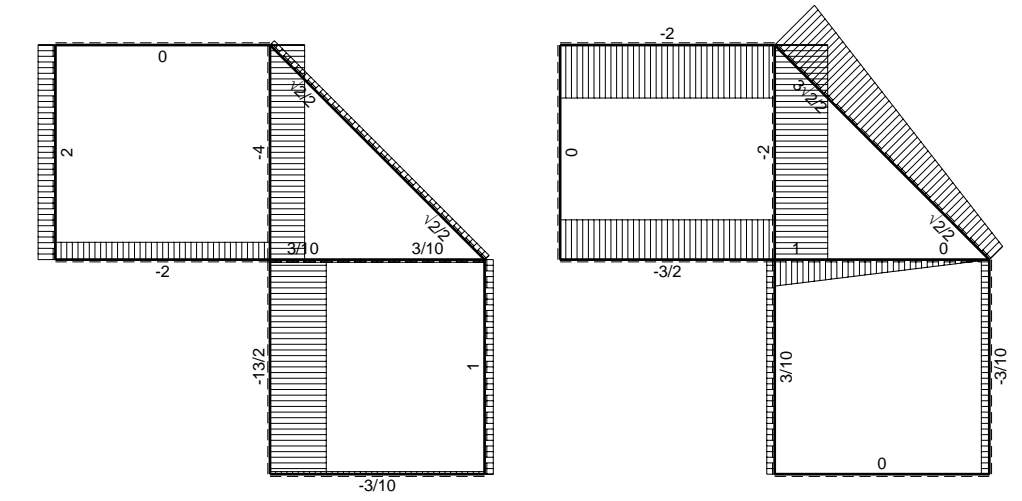
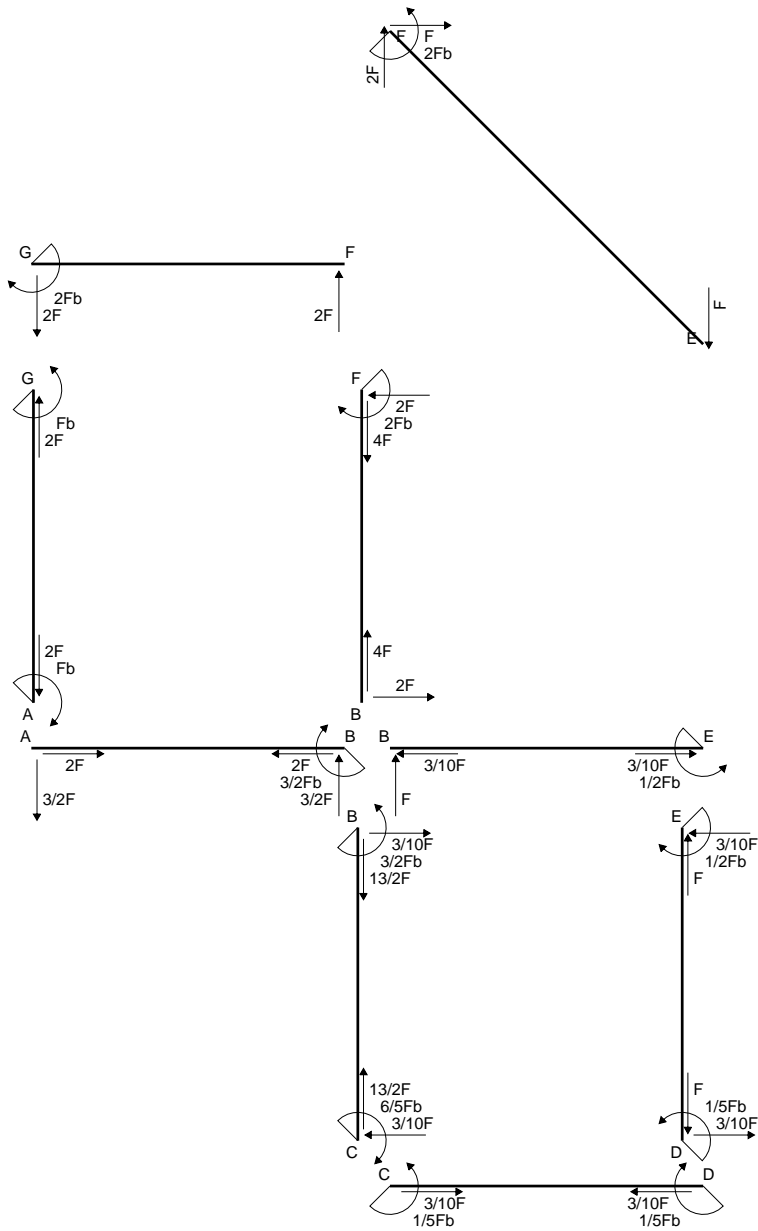

← (+) → F

↑ (+) ↓ F

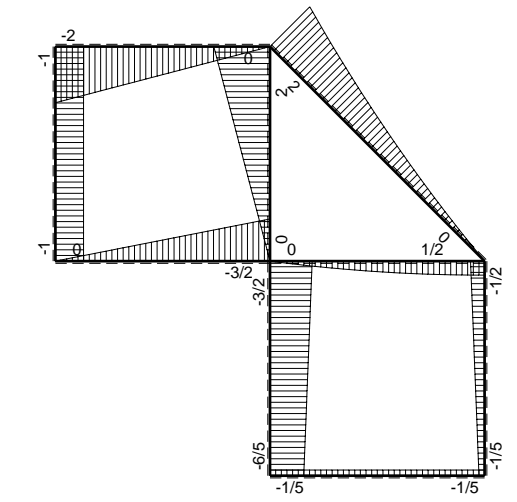

⊙ (+) ⊙ F_b

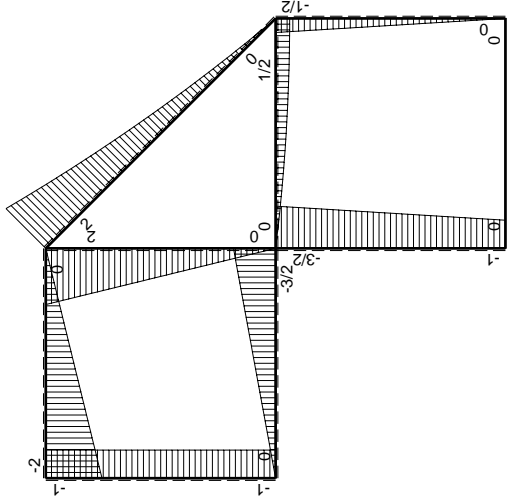
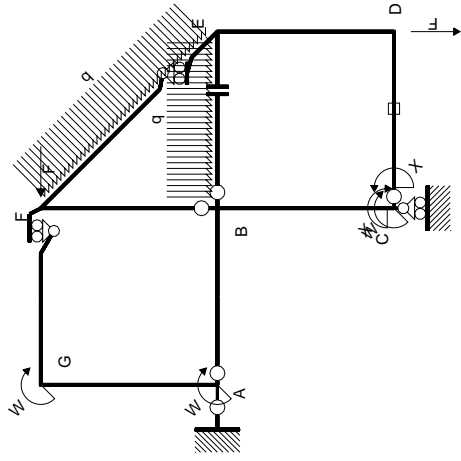

Schema di calcolo iperstatico

(\oplus) M_0 flessione da carichi assegnati

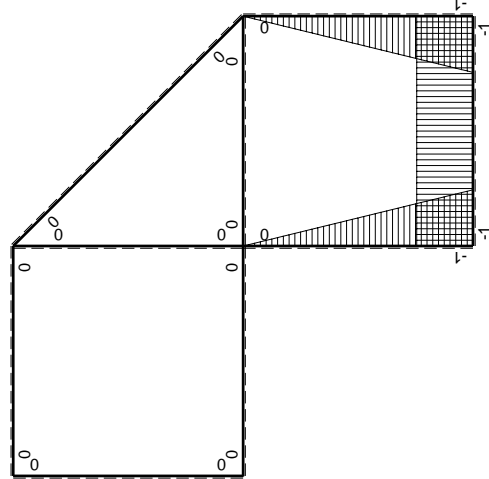

(\oplus) M_x flessione da iperstatica $X=1$

Quadro contribuiti PLV per iperstatica $X=W_{cd}$

\rightarrow	$M_x(x)$	$M_0(x)$	$M_x M_0$	$M_x M_x$	$\int M_x M_0 / E J dx$	$\int X M_x M_x / E J dx$
AB b	0	-3/2Fx	0	0	0	0
BA b	0	3/2Fb-3/2Fx	0	0	0	0
BC b	-x/b	-3/2Fb+1/2Fx	3/2Fx-1/2Fx ² /b	x ² /b ²	7/12Fb ² /EJ	1/3Xb/EJ
CB b	1-x/b	Fb+1/2Fx	Fb-1/2Fx-1/2Fx ² /b	1-2x/b+x ² /b ²	0	Xb/EJ
CD b	-1	0	0	1	0	0
DC b	1	0	0	1	0	0
DE b	-1+x/b	-1/2Fx	1/2Fx-1/2Fx ² /b	1-2x/b+x ² /b ²	1/12Fb ² /EJ	1/3Xb/EJ
ED b	x/b	1/2Fb-1/2Fx	1/2Fx-1/2Fx ² /b	x ² /b ²	0	0
EF $\sqrt{2}b$	0	$\sqrt{2}/2Fx+1/2qx^2$	0	0	0	0
FG b	0	-2Fx	0	0	0	0
GF b	0	2Fb-2Fx	0	0	0	0
GA b	0	-Fb	0	0	0	0
AG b	0	Fb	0	0	0	0
FB b	0	2Fb-2Fx	0	0	0	0
BF b	0	-2Fx	0	0	0	0
BE b	0	Fx-1/2qx ²	0	0	0	0
EB b	0	-1/2Fb+1/2qx ²	0	0	0	0
CD	elongazione asta $N_{1,cd} \epsilon_{cd} L_{cd}$				-Fb ² /EJ	
	totali				-1/3Fb ² /EJ	5/3Xb/EJ
	iperstatica $X=W_{cd}$				1/5Fb	

Sviluppi di calcolo iperstatica

$$L_{BC}^{xx} = \int_0^b (x^2/b^2) 1/EJ dx = [1/3 x^3/b^2]_0^b 1/EJ$$

$$= (1/3 b) 1/EJ = 1/3 b/EJ$$

$$L_{CB}^{xx} = \int_0^b (1 - 2x/b + x^2/b^2) 1/EJ dx = [x - x^2/b + 1/3 x^3/b^2]_0^b 1/EJ$$

$$= (b - b + 1/3 b) 1/EJ = 1/3 b/EJ$$

$$L_{CD}^{xx} = \int_0^b (1) 1/EJ dx = [x]_0^b 1/EJ$$

$$= (b) 1/EJ = b/EJ$$

$$L_{DC}^{xx} = \int_0^b (1) 1/EJ dx = [x]_0^b 1/EJ$$

$$= (b) 1/EJ = b/EJ$$

$$L_{DE}^{xx} = \int_0^b (1 - 2x/b + x^2/b^2) 1/EJ dx = [x - x^2/b + 1/3 x^3/b^2]_0^b 1/EJ$$

$$= (b - b + 1/3 b) 1/EJ = 1/3 b/EJ$$

$$L_{ED}^{xx} = \int_0^b (x^2/b^2) 1/EJ dx = [1/3 x^3/b^2]_0^b 1/EJ$$

$$= (1/3 b) 1/EJ = 1/3 b/EJ$$

$$L_{BC}^{x_0} = \int_0^b (3/2 x/b - 1/2 x^2/b^2) Fb 1/EJ dx = [3/4 x^2/b - 1/6 x^3/b^2]_0^b Fb 1/EJ$$

$$= (3/4 b - 1/6 b) Fb 1/EJ = 7/12 Fb^2/EJ$$

$$L_{CB}^{x_0} = \int_0^b (1 - 1/2 x/b - 1/2 x^2/b^2) Fb 1/EJ dx = [x - 1/4 x^2/b - 1/6 x^3/b^2]_0^b Fb 1/EJ$$

$$= (b - 1/4 b - 1/6 b) Fb 1/EJ = 7/12 Fb^2/EJ$$

$$L_{DE}^{x_0} = \int_0^b (1/2 x/b - 1/2 x^2/b^2) Fb 1/EJ dx = [1/4 x^2/b - 1/6 x^3/b^2]_0^b Fb 1/EJ$$

$$= (1/4 b - 1/6 b) Fb 1/EJ = 1/12 Fb^2/EJ$$

$$L_{ED}^{x_0} = \int_0^b (1/2 x/b - 1/2 x^2/b^2) Fb 1/EJ dx = [1/4 x^2/b - 1/6 x^3/b^2]_0^b Fb 1/EJ$$

$$= (1/4 b - 1/6 b) Fb 1/EJ = 1/12 Fb^2/EJ$$

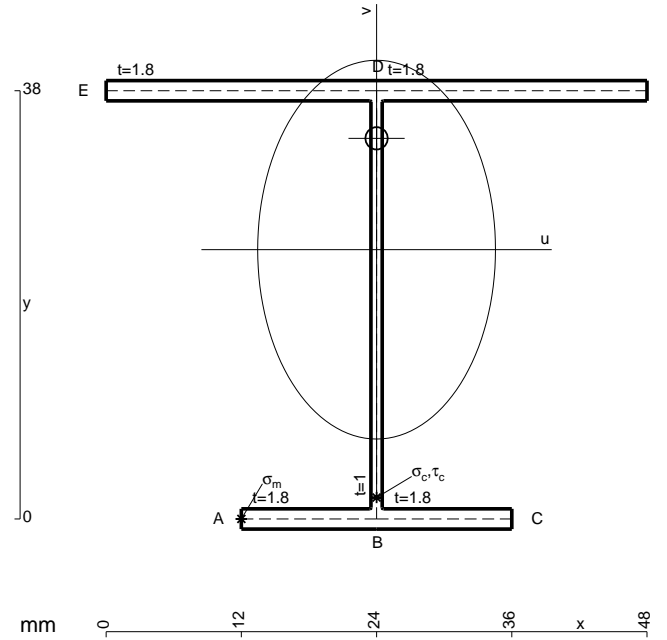

- A = 167.6 mm²
- J_u = 47339. mm⁴
- J_v = 18662. mm⁴
- J_t = 152.6 mm⁴
- y_o = 9.88 mm
- y_g = 23.9 mm
- N = 247.5 N
- T_y = 742.5 N
- M_x = 448000. Nmm
- x_m = 12. mm
- u_m = -12. mm
- v_m = -23.9 mm
- σ_m = N/A - Mv/J_u = 227.6 N/mm²
- x_c = 24. mm
- v_c = -23.9 mm
- σ_c = N/A - Mv/J_u = 227.6 N/mm²
- τ_c = TS_t/tJ_u = 16.19 N/mm²
- τ_g = TS_t/tJ_u = 16.19 N/mm²
- t_c = 350. mm
- σ_o = √(σ² + 3τ²) = 229.4 N/mm²

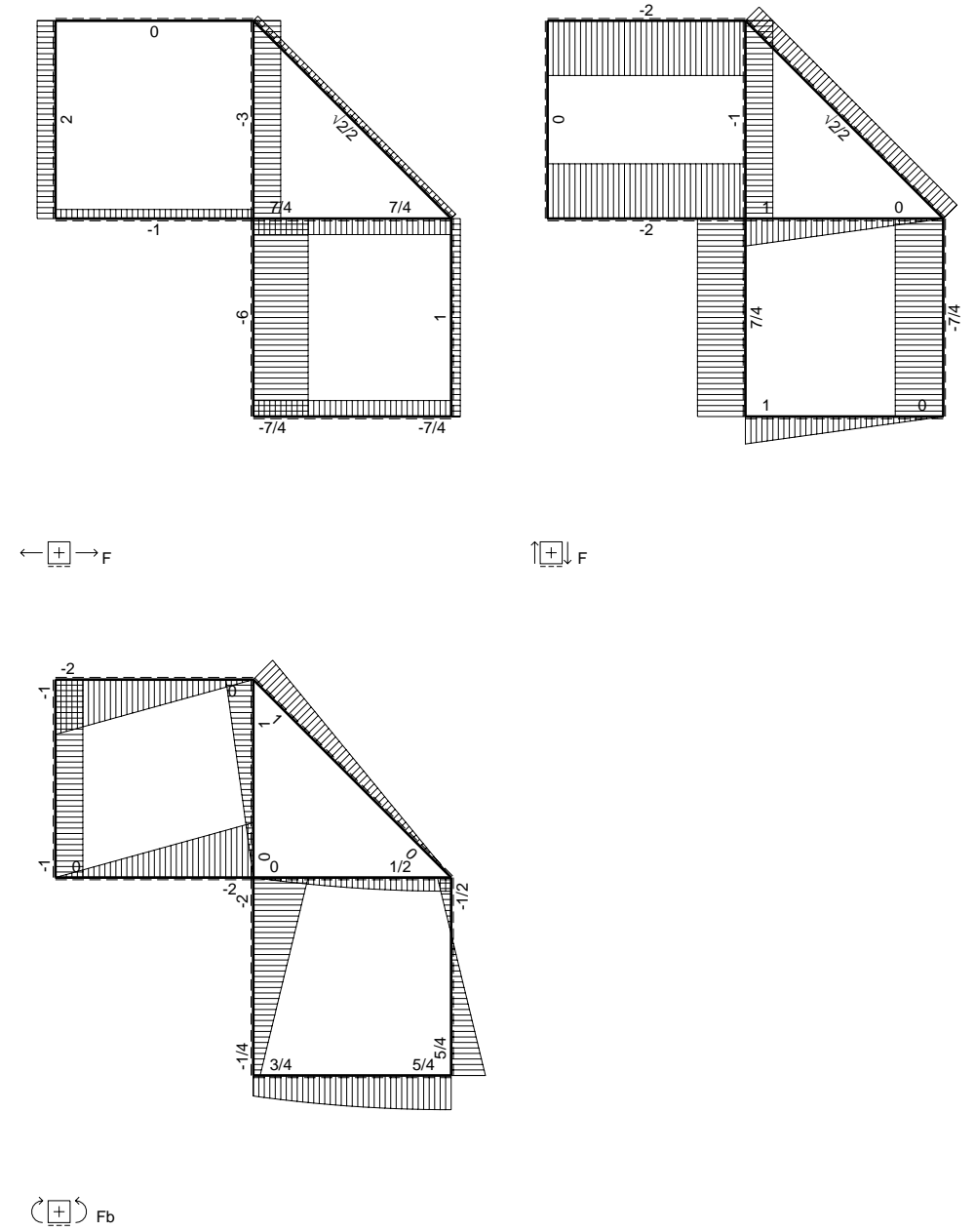
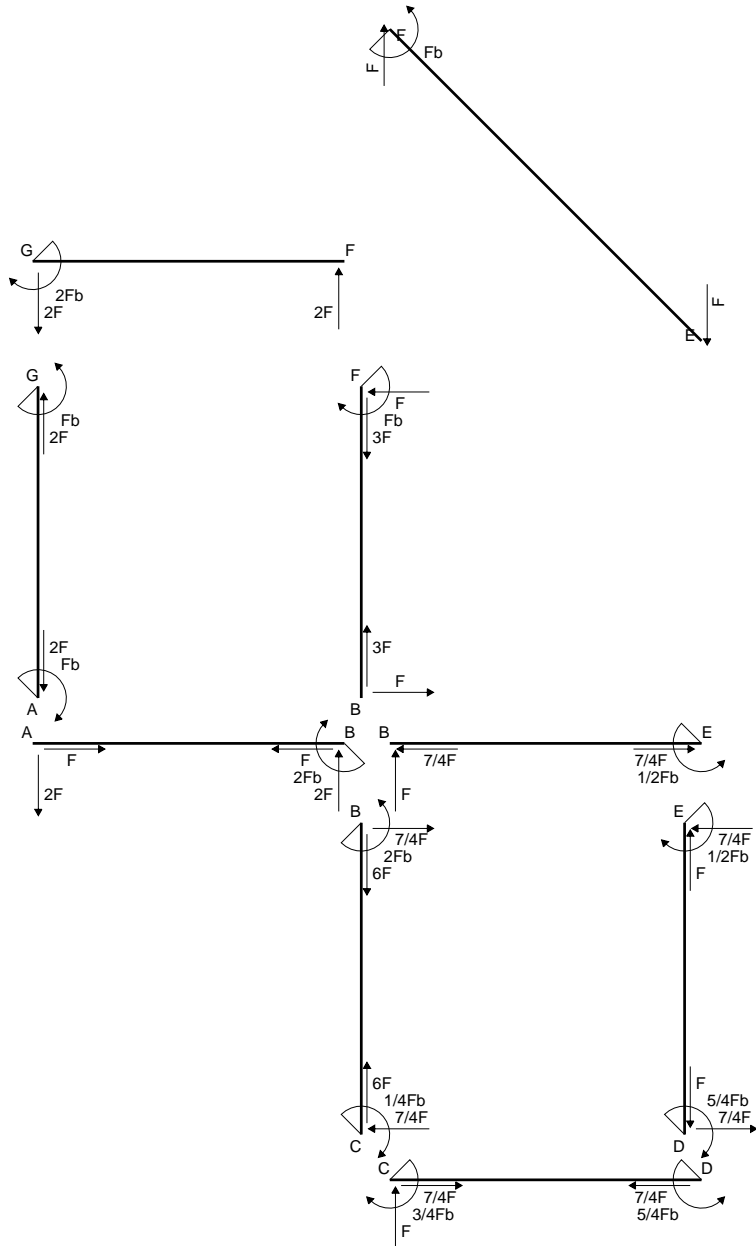

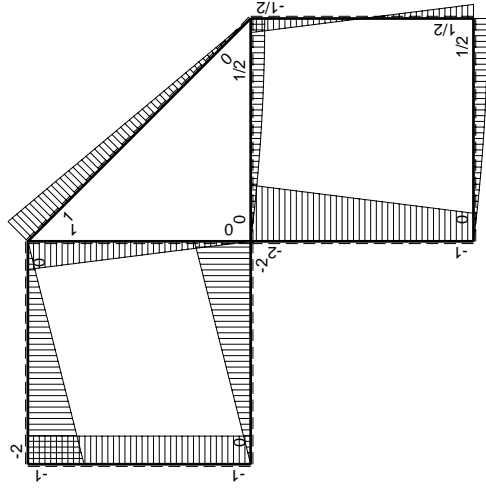
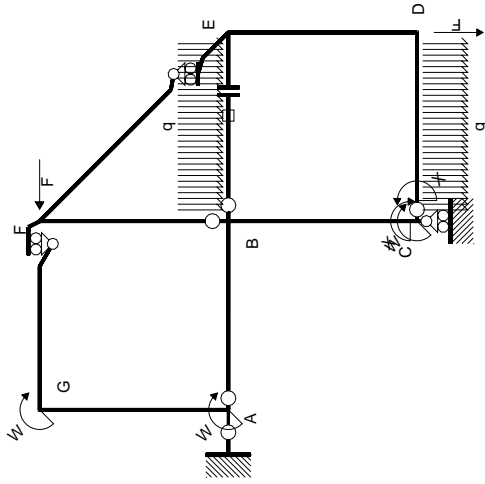

M_0 flessione da carichi assegnati

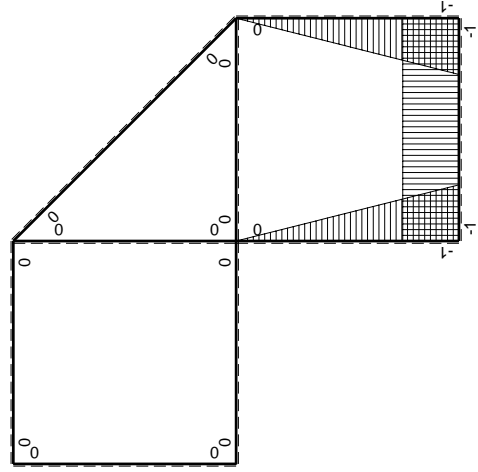

M_x flessione da iperstatica $X=1$

Quadro contribuiti PLV per iperstatica $X=W_{cd}$

\rightarrow	$M_x(x)$	$M_0(x)$	$M_x M_0$	$M_x M_x$	$\int M_x M_0 / EJ dx$	$\int X M_x M_x / EJ dx$
AB b	0	-2Fx	0	0	0	0
BA b	0	2Fb-2Fx	0	0	0	0
BC b	-x/b	-2Fb+Fx	$2Fx-Fx^2/b$	x^2/b^2	$2/3Fb^2/EJ$	$1/3Xb/EJ$
CB b	$1-x/b$	Fb+Fx	$Fb-Fx^2/b$	$1-2x/b+x^2/b^2$	$-1/3Fb^2/EJ$	Xb/EJ
CD b	-1	$Fx-1/2qx^2$	$-Fx+1/2Fx^2/b$	1	$-1/12Fb^2/EJ$	$1/3Xb/EJ$
DC b	1	$-1/2Fb+1/2qx^2$	$-1/2Fb+1/2Fx^2/b$	1	$-1/12Fb^2/EJ$	$1/3Xb/EJ$
DE b	$-1+x/b$	$1/2Fb-Fx$	$-1/2Fb+3/2Fx-Fx^2/b$	$1-2x/b+x^2/b^2$	0	0
ED b	x/b	$1/2Fb-Fx$	$1/2Fx-Fx^2/b$	x^2/b^2	0	0
EF $\sqrt{2}b$	0	$\sqrt{2}2Fx$	0	0	0	0
FG b	0	-2Fx	0	0	0	0
GF b	0	2Fb-2Fx	0	0	0	0
GA b	0	-Fb	0	0	0	0
AG b	0	Fb	0	0	0	0
FB b	0	Fb-Fx	0	0	0	0
BF b	0	-Fx	0	0	0	0
BE b	0	$Fx-1/2qx^2$	0	0	0	0
EB b	0	$-1/2Fb+1/2qx^2$	0	0	0	0
BE	elongazione asta $N_{1BE} \epsilon_{BE} = L_{BE}$				Fb^2/EJ	
	totali				$5/4Fb^2/EJ$	$5/3Xb/EJ$
	iperstatica $X=W_{cd}$				$-3/4Fb$	

Sviluppi di calcolo iperstatica

$$L_{BC}^{xx} = \int_0^b (x^2/b^2) 1/EJ dx = [1/3 x^3/b^2]_0^b 1/EJ$$

$$= (1/3 b) 1/EJ = 1/3 b/EJ$$

$$L_{CB}^{xx} = \int_0^b (1 - 2x/b + x^2/b^2) 1/EJ dx = [x - x^2/b + 1/3 x^3/b^2]_0^b 1/EJ$$

$$= (b - b + 1/3 b) 1/EJ = 1/3 b/EJ$$

$$L_{CD}^{xx} = \int_0^b (1) 1/EJ dx = [x]_0^b 1/EJ$$

$$= (b) 1/EJ = b/EJ$$

$$L_{DC}^{xx} = \int_0^b (1) 1/EJ dx = [x]_0^b 1/EJ$$

$$= (b) 1/EJ = b/EJ$$

$$L_{DE}^{xx} = \int_0^b (1 - 2x/b + x^2/b^2) 1/EJ dx = [x - x^2/b + 1/3 x^3/b^2]_0^b 1/EJ$$

$$= (b - b + 1/3 b) 1/EJ = 1/3 b/EJ$$

$$L_{ED}^{xx} = \int_0^b (x^2/b^2) 1/EJ dx = [1/3 x^3/b^2]_0^b 1/EJ$$

$$= (1/3 b) 1/EJ = 1/3 b/EJ$$

$$L_{BC}^{xo} = \int_0^b (2x/b - x^2/b^2) Fb 1/EJ dx = [x^2/b - 1/3 x^3/b^2]_0^b Fb 1/EJ$$

$$= (b - 1/3 b) Fb 1/EJ = 2/3 Fb^2/EJ$$

$$L_{CB}^{xo} = \int_0^b (1 - x^2/b^2) Fb 1/EJ dx = [x - 1/3 x^3/b^2]_0^b Fb 1/EJ$$

$$= (b - 1/3 b) Fb 1/EJ = 2/3 Fb^2/EJ$$

$$L_{CD}^{xo} = \int_0^b (-x/b + 1/2 x^2/b^2) Fb 1/EJ dx = [-1/2 x^2/b + 1/6 x^3/b^2]_0^b Fb 1/EJ$$

$$= (-1/2 b + 1/6 b) Fb 1/EJ = -1/3 Fb^2/EJ$$

$$L_{DC}^{xo} = \int_0^b (-1/2 + 1/2 x^2/b^2) Fb 1/EJ dx = [-1/2 x + 1/6 x^3/b^2]_0^b Fb 1/EJ$$

$$= (-1/2 b + 1/6 b) Fb 1/EJ = -1/3 Fb^2/EJ$$

$$L_{DE}^{xo} = \int_0^b (-1/2 + 3/2 x/b - x^2/b^2) Fb 1/EJ dx = [-1/2 x + 3/4 x^2/b - 1/3 x^3/b^2]_0^b Fb 1/EJ$$

$$= (-1/2 b + 3/4 b - 1/3 b) Fb 1/EJ = -1/12 Fb^2/EJ$$

$$L_{ED}^{xo} = \int_0^b (1/2 x/b - x^2/b^2) Fb 1/EJ dx = [1/4 x^2/b - 1/3 x^3/b^2]_0^b Fb 1/EJ$$

$$= (1/4 b - 1/3 b) Fb 1/EJ = -1/12 Fb^2/EJ$$

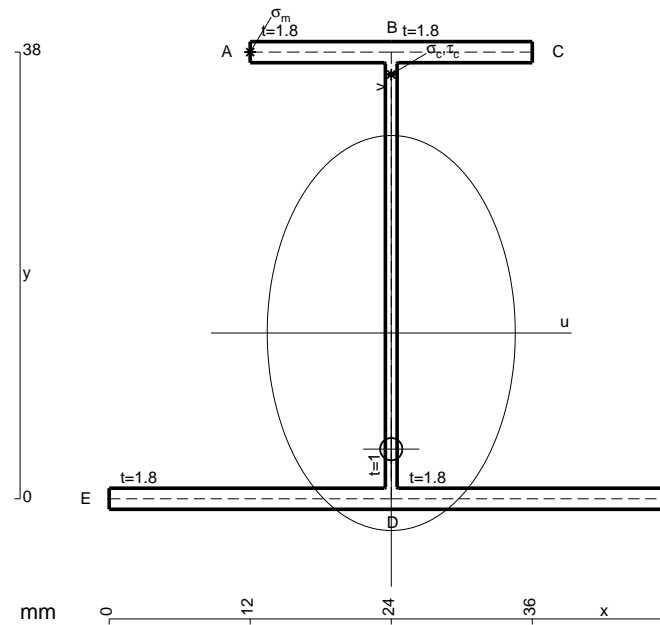

$$A = 167.6 \text{ mm}^2$$

$$J_u = 47339. \text{ mm}^4$$

$$J_v = 18662. \text{ mm}^4$$

$$J_t = 152.6 \text{ mm}^4$$

$$y_o = -9.88 \text{ mm}$$

$$y_g = 14.1 \text{ mm}$$

$$T_y = -680. \text{ N}$$

$$M_x = -462400. \text{ Nmm}$$

$$x_m = 12. \text{ mm}$$

$$y_m = 38. \text{ mm}$$

$$u_m = -12. \text{ mm}$$

$$v_m = 23.9 \text{ mm}$$

$$\sigma_m = -Mv/J_u = 233.4 \text{ N/mm}^2$$

$$x_c = 24. \text{ mm}$$

$$y_c = 38. \text{ mm}$$

$$v_c = 23.9 \text{ mm}$$

$$\sigma_c = -Mv/J_u = 233.4 \text{ N/mm}^2$$

$$\tau_c = TS/tJ_u = 14.83 \text{ N/mm}^2$$

$$\tau_g = TS/tJ_u = 14.83 \text{ N/mm}^2$$

$$t_c = 340. \text{ mm}$$

$$\sigma_o = \sqrt{\sigma^2 + 3\tau^2} = 234.8 \text{ N/mm}^2$$

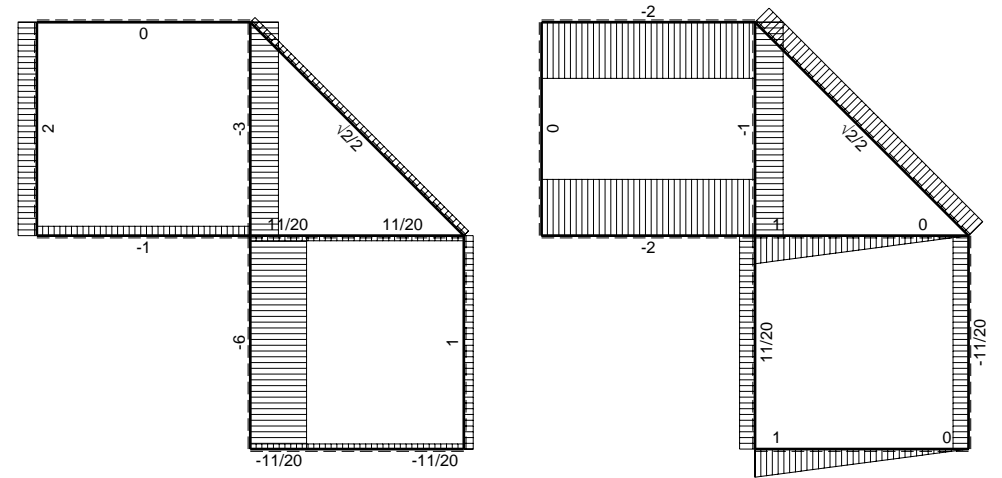
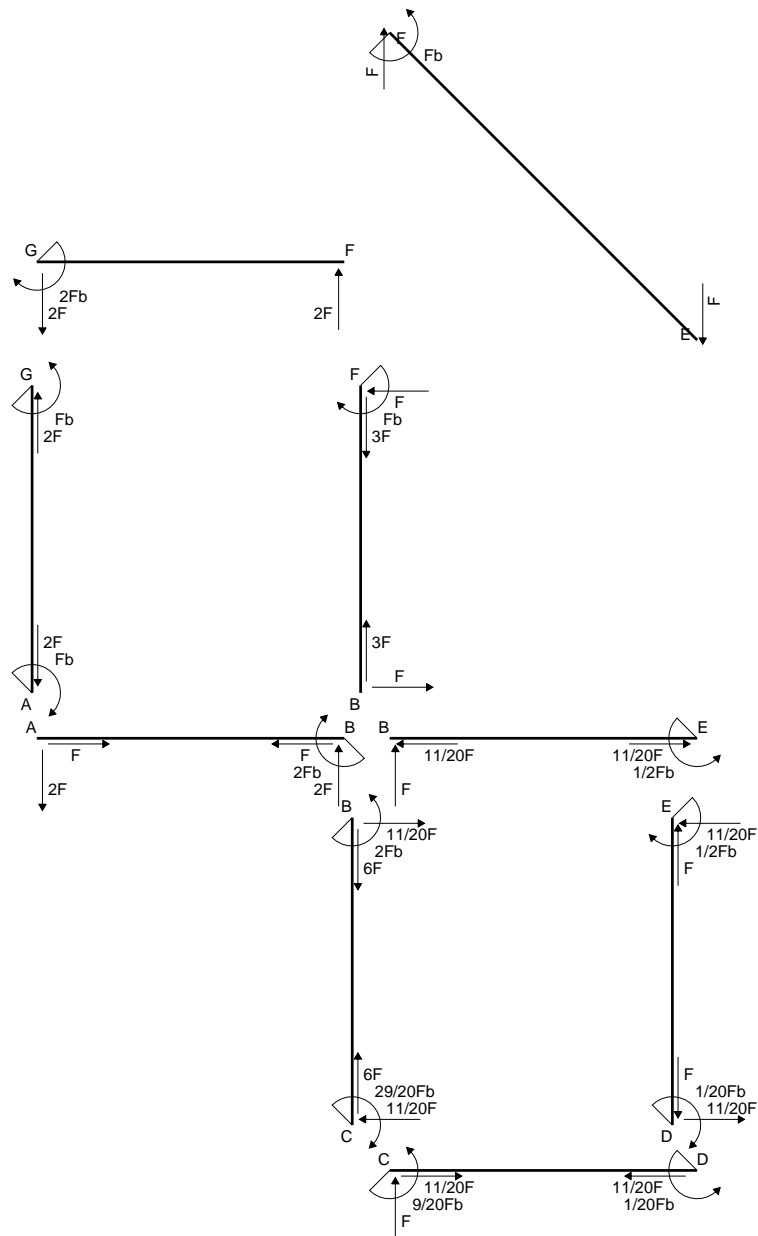

← ⊕ → F

↑ ⊕ ↓ F

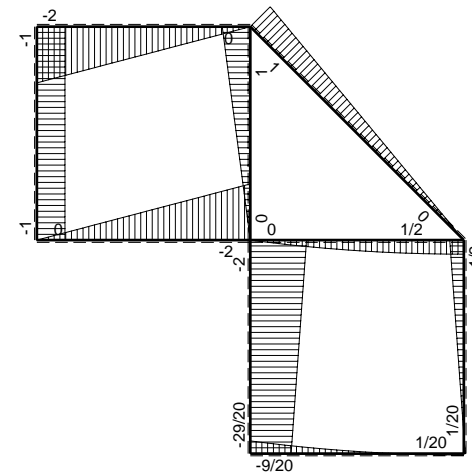

⊕ ⊖ Fb

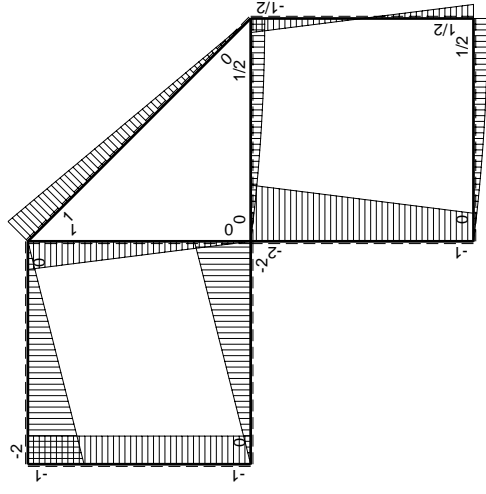
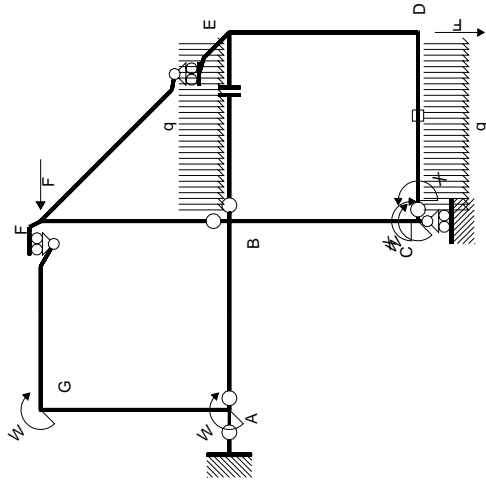

(\oplus) M_0 flessione da carichi assegnati

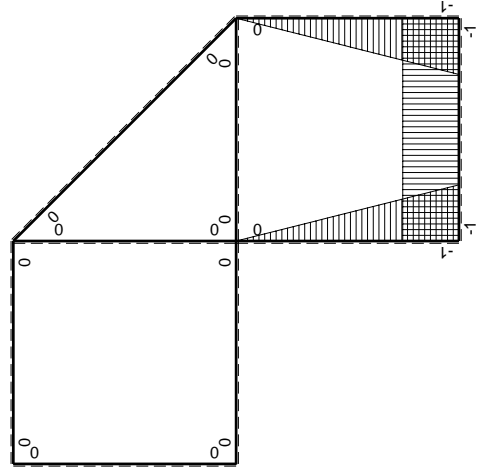

(\oplus) M_x flessione da iperstatica $X=1$

Quadro contribuiti PLV per iperstatica $X=W_{cd}$

\rightarrow	$M_x(x)$	$M_0(x)$	$M_x M_0$	$M_x M_x$	$\int M_x M_0 / EJ dx$	$\int X M_x M_x / EJ dx$
AB b	0	-2Fx	0	0	0	0
BA b	0	2Fb-2Fx	0	0	0	0
BC b	-x/b	-2Fb+Fx	$2Fx-Fx^2/b$	x^2/b^2	$2/3Fb^2/EJ$	$1/3Xb/EJ$
CB b	1-x/b	Fb+Fx	$Fb-Fx^2/b$	$1-2x/b+x^2/b^2$	$-1/3Fb^2/EJ$	Xb/EJ
CD b	-1	$Fx-1/2qx^2$	$-Fx+1/2Fx^2/b$	1	$-1/12Fb^2/EJ$	$1/3Xb/EJ$
DC b	1	$-1/2Fb+1/2qx^2$	$-1/2Fb+1/2Fx^2/b$	1	$-1/12Fb^2/EJ$	$1/3Xb/EJ$
DE b	-1+x/b	$1/2Fb-Fx$	$-1/2Fb+3/2Fx-Fx^2/b$	$1-2x/b+x^2/b^2$	0	0
ED b	x/b	$1/2Fb-Fx$	$1/2Fx-Fx^2/b$	x^2/b^2	0	0
EF $\sqrt{2}b$	0	$\sqrt{2}2Fx$	0	0	0	0
FG b	0	-2Fx	0	0	0	0
GF b	0	2Fb-2Fx	0	0	0	0
GA b	0	-Fb	0	0	0	0
AG b	0	Fb	0	0	0	0
FB b	0	Fb-Fx	0	0	0	0
BF b	0	-Fx	0	0	0	0
BE b	0	$Fx-1/2qx^2$	0	0	0	0
EB b	0	$-1/2Fb+1/2qx^2$	0	0	0	0
CD	elongazione asta $N_{1,cd} \epsilon_{cd} L_{cd}$				$-Fb^2/EJ$	
	totali				$-3/4Fb^2/EJ$	$5/3Xb/EJ$
	iperstatica $X=W_{cd}$				$9/20Fb$	

Sviluppi di calcolo iperstatica

$$L_{BC}^{xx} = \int_0^b (x^2/b^2) 1/EJ dx = [1/3 x^3/b^2]_0^b 1/EJ$$

$$= (1/3 b) 1/EJ = 1/3 b/EJ$$

$$L_{CB}^{xx} = \int_0^b (1 - 2x/b + x^2/b^2) 1/EJ dx = [x - x^2/b + 1/3 x^3/b^2]_0^b 1/EJ$$

$$= (b - b + 1/3 b) 1/EJ = 1/3 b/EJ$$

$$L_{CD}^{xx} = \int_0^b (1) 1/EJ dx = [x]_0^b 1/EJ$$

$$= (b) 1/EJ = b/EJ$$

$$L_{DC}^{xx} = \int_0^b (1) 1/EJ dx = [x]_0^b 1/EJ$$

$$= (b) 1/EJ = b/EJ$$

$$L_{DE}^{xx} = \int_0^b (1 - 2x/b + x^2/b^2) 1/EJ dx = [x - x^2/b + 1/3 x^3/b^2]_0^b 1/EJ$$

$$= (b - b + 1/3 b) 1/EJ = 1/3 b/EJ$$

$$L_{ED}^{xx} = \int_0^b (x^2/b^2) 1/EJ dx = [1/3 x^3/b^2]_0^b 1/EJ$$

$$= (1/3 b) 1/EJ = 1/3 b/EJ$$

$$L_{BC}^{xo} = \int_0^b (2x/b - x^2/b^2) Fb 1/EJ dx = [x^2/b - 1/3 x^3/b^2]_0^b Fb 1/EJ$$

$$= (b - 1/3 b) Fb 1/EJ = 2/3 Fb^2/EJ$$

$$L_{CB}^{xo} = \int_0^b (1 - x^2/b^2) Fb 1/EJ dx = [x - 1/3 x^3/b^2]_0^b Fb 1/EJ$$

$$= (b - 1/3 b) Fb 1/EJ = 2/3 Fb^2/EJ$$

$$L_{CD}^{xo} = \int_0^b (-x/b + 1/2 x^2/b^2) Fb 1/EJ dx + 1 (-1) 1 Fb^2/EJ$$

$$= [-1/2 x^2/b + 1/6 x^3/b^2]_0^b Fb 1/EJ + 1 (-1) 1 Fb^2/EJ$$

$$= (-1/2 b + 1/6 b) Fb 1/EJ + 1 (-1) 1 Fb^2/EJ = -4/3 Fb^2/EJ$$

$$L_{DC}^{xo} = \int_0^b (-1/2 + 1/2 x^2/b^2) Fb 1/EJ dx + 1 (-1) 1 Fb^2/EJ$$

$$= [-1/2 x + 1/6 x^3/b^2]_0^b Fb 1/EJ + 1 (-1) 1 Fb^2/EJ$$

$$= (-1/2 b + 1/6 b) Fb 1/EJ + 1 (-1) 1 Fb^2/EJ = -4/3 Fb^2/EJ$$

$$L_{DE}^{xo} = \int_0^b (-1/2 + 3/2 x/b - x^2/b^2) Fb 1/EJ dx = [-1/2 x + 3/4 x^2/b - 1/3 x^3/b^2]_0^b Fb 1/EJ$$

$$= (-1/2 b + 3/4 b - 1/3 b) Fb 1/EJ = -1/12 Fb^2/EJ$$

$$L_{ED}^{xo} = \int_0^b (1/2 x/b - x^2/b^2) Fb 1/EJ dx = [1/4 x^2/b - 1/3 x^3/b^2]_0^b Fb 1/EJ$$

$$= (1/4 b - 1/3 b) Fb 1/EJ = -1/12 Fb^2/EJ$$

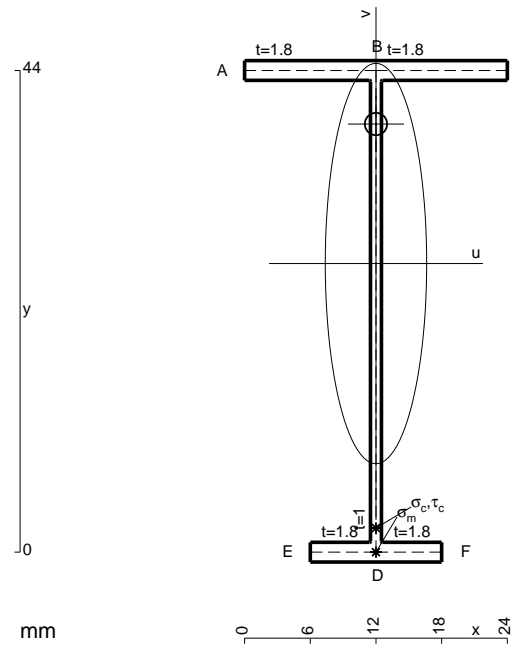

- A = 108.8 mm²
- J_u = 36386. mm⁴
- J_v = 2333. mm⁴
- J_t = 84.65 mm⁴
- y_o = 12.74 mm
- y_g = 26.37 mm
- N = -320. N
- T_y = -640. N
- M_x = -268800. Nmm
- x_m = 12. mm
- v_m = -26.37 mm
- σ_m = N/A - Mv/J_u = -197.7 N/mm²
- y_c = 3. mm
- u_c = -12. mm
- v_c = -23.37 mm
- σ_c = N/A - Mv/J_u = -197.7 N/mm²
- τ_c = TS/tJ_u = 10.02 N/mm²
- τ_g = TS/tJ_u = 10.02 N/mm²
- t_c = 320. mm
- σ_o = √σ² + 3τ² = 198.5 N/mm²

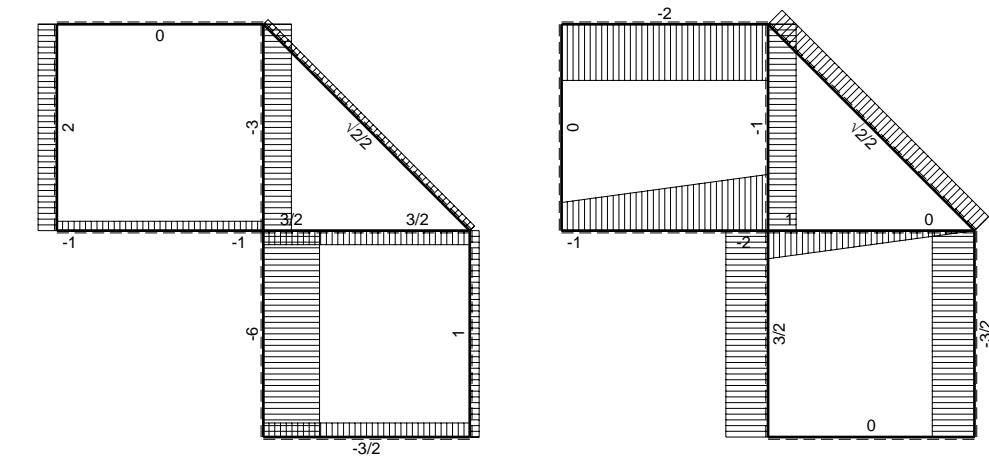
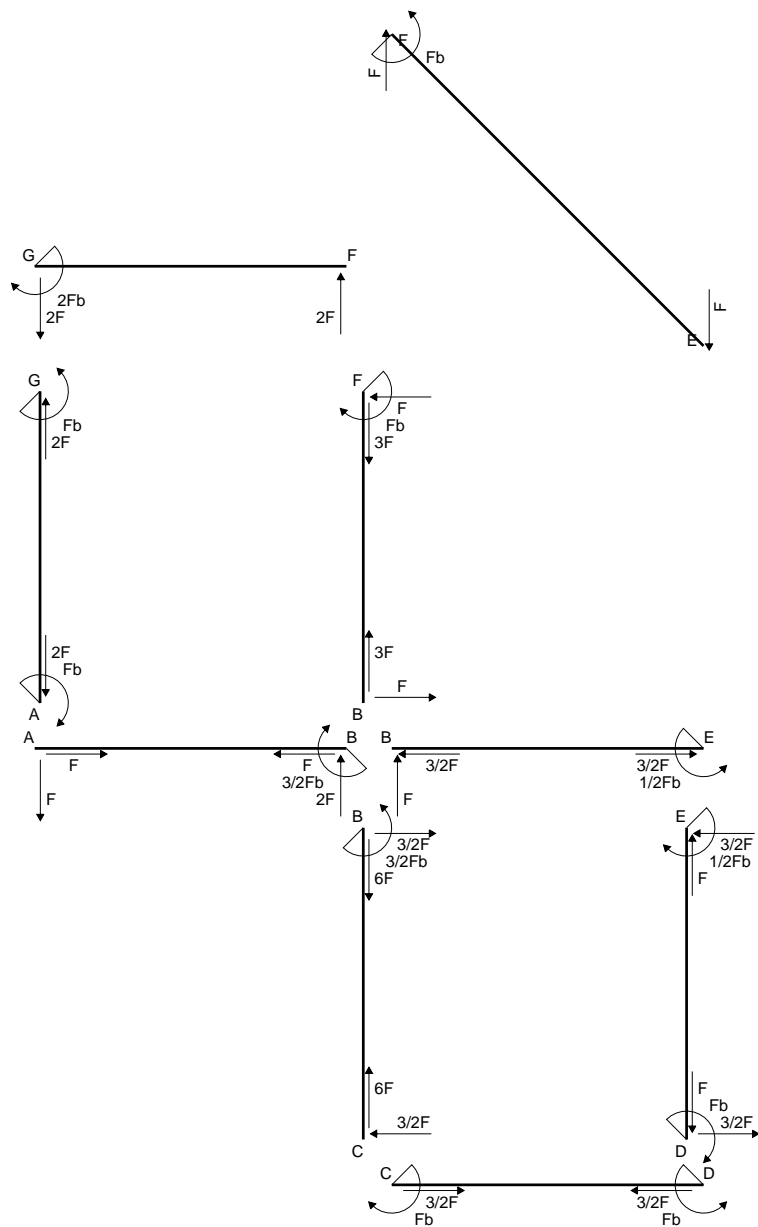

← ⊕ → F

↑ ⊕ ↓ F

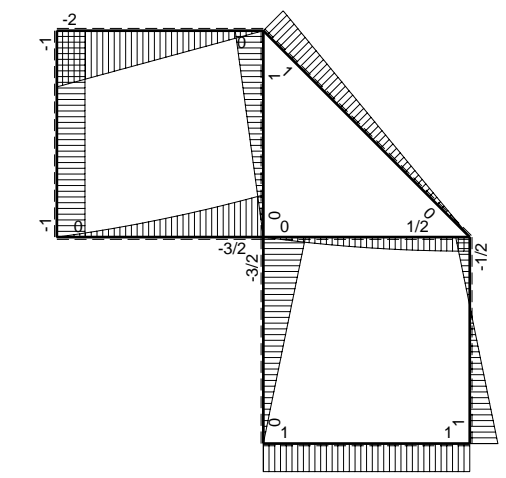

⊕ ⊖ Fb

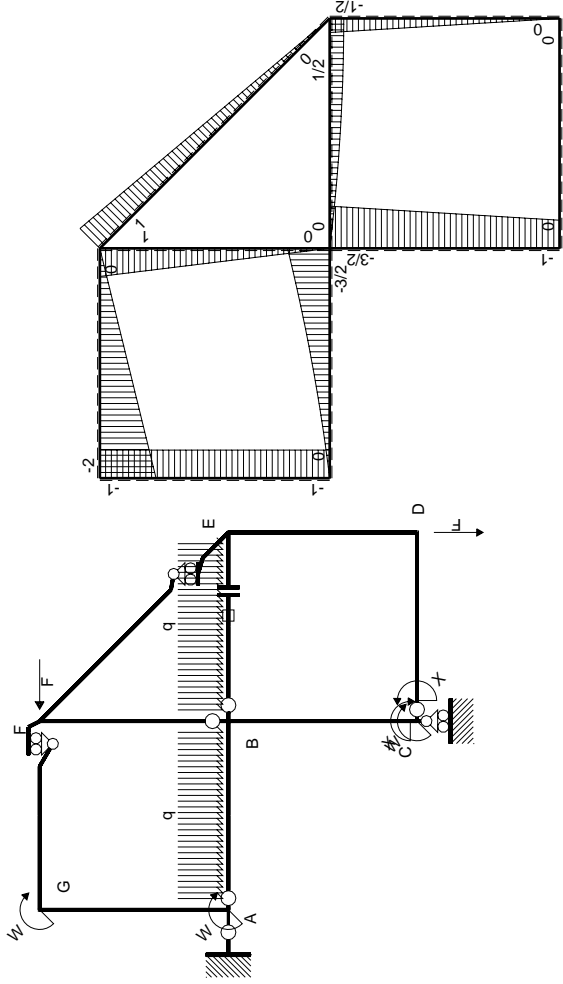

Schema di calcolo iperstatico

M_0 flessione da carichi assegnati

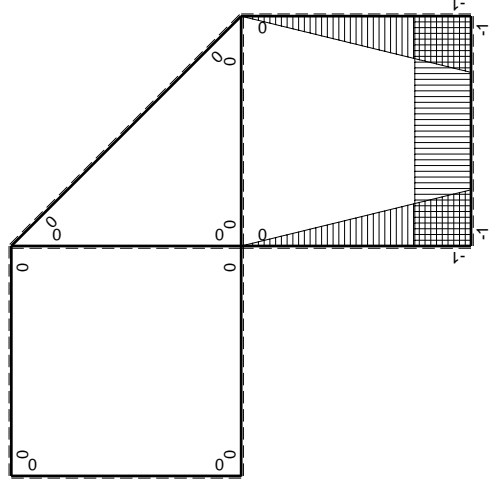

M_x flessione da iperstatica X=1

Quadro contribuiti PLV per iperstatica X=W_{cd}

→	$M_x(x)$	$M_0(x)$	$M_x M_0$	$M_x M_x$	$\int M_x M_0 / E J dx$	$\int X M_x M_x / E J dx$
AB b	0	$-Fx - 1/2qx^2$	0	0	0	0
BA b	0	$3/2Fb - 2Fx + 1/2qx^2$	0	0	0	0
BC b	$-x/b$	$-3/2Fb + 1/2Fx$	$3/2Fx - 1/2Fx^2/b$	x^2/b^2	$7/12Fb^2/EJ$	$1/3Xb/EJ$
CB b	$1-x/b$	$Fb + 1/2Fx$	$Fb - 1/2Fx - 1/2Fx^2/b$	$1 - 2x/b + x^2/b^2$	0	0
CD b	-1	0	0	1	0	Xb/EJ
DC b	1	0	0	1	0	0
DE b	$-1+x/b$	$-1/2Fx$	$1/2Fx - 1/2Fx^2/b$	$1 - 2x/b + x^2/b^2$	$1/12Fb^2/EJ$	$1/3Xb/EJ$
ED b	x/b	$1/2Fb - 1/2Fx$	$1/2Fx - 1/2Fx^2/b$	x^2/b^2	0	0
EF $\sqrt{2}b$	0	$\sqrt{2}/2Fx$	0	0	0	0
FG b	0	$-2Fx$	0	0	0	0
GF b	0	$2Fb - 2Fx$	0	0	0	0
GA b	0	$-Fb$	0	0	0	0
AG b	0	Fb	0	0	0	0
FB b	0	$Fb - Fx$	0	0	0	0
BF b	0	$-Fx$	0	0	0	0
BE b	0	$Fx - 1/2qx^2$	0	0	0	0
EB b	0	$-1/2Fb + 1/2qx^2$	0	0	0	0
BE	elongazione asta $N_{1, BE}^E - L_{BE}^{L-BE}$				Fb^2/EJ	
	totali				$5/3Fb^2/EJ$	$5/3Xb/EJ$
	iperstatica X=W _{cd}				$-Fb$	

Sviluppi di calcolo iperstatica

$$L_{BC}^{xx} = \int_0^b (x^2/b^2) 1/EJ dx = [1/3 x^3/b^2]_0^b 1/EJ$$

$$= (1/3 b) 1/EJ = 1/3 b/EJ$$

$$L_{CB}^{xx} = \int_0^b (1 - 2x/b + x^2/b^2) 1/EJ dx = [x - x^2/b + 1/3 x^3/b^2]_0^b 1/EJ$$

$$= (b - b + 1/3 b) 1/EJ = 1/3 b/EJ$$

$$L_{CD}^{xx} = \int_0^b (1) 1/EJ dx = [x]_0^b 1/EJ$$

$$= (b) 1/EJ = b/EJ$$

$$L_{DC}^{xx} = \int_0^b (1) 1/EJ dx = [x]_0^b 1/EJ$$

$$= (b) 1/EJ = b/EJ$$

$$L_{DE}^{xx} = \int_0^b (1 - 2x/b + x^2/b^2) 1/EJ dx = [x - x^2/b + 1/3 x^3/b^2]_0^b 1/EJ$$

$$= (b - b + 1/3 b) 1/EJ = 1/3 b/EJ$$

$$L_{ED}^{xx} = \int_0^b (x^2/b^2) 1/EJ dx = [1/3 x^3/b^2]_0^b 1/EJ$$

$$= (1/3 b) 1/EJ = 1/3 b/EJ$$

$$L_{BC}^{xo} = \int_0^b (3/2 x/b - 1/2 x^2/b^2) Fb 1/EJ dx = [3/4 x^2/b - 1/6 x^3/b^2]_0^b Fb 1/EJ$$

$$= (3/4 b - 1/6 b) Fb 1/EJ = 7/12 Fb^2/EJ$$

$$L_{CB}^{xo} = \int_0^b (1 - 1/2 x/b - 1/2 x^2/b^2) Fb 1/EJ dx = [x - 1/4 x^2/b - 1/6 x^3/b^2]_0^b Fb 1/EJ$$

$$= (b - 1/4 b - 1/6 b) Fb 1/EJ = 7/12 Fb^2/EJ$$

$$L_{DE}^{xo} = \int_0^b (1/2 x/b - 1/2 x^2/b^2) Fb 1/EJ dx = [1/4 x^2/b - 1/6 x^3/b^2]_0^b Fb 1/EJ$$

$$= (1/4 b - 1/6 b) Fb 1/EJ = 1/12 Fb^2/EJ$$

$$L_{ED}^{xo} = \int_0^b (1/2 x/b - 1/2 x^2/b^2) Fb 1/EJ dx = [1/4 x^2/b - 1/6 x^3/b^2]_0^b Fb 1/EJ$$

$$= (1/4 b - 1/6 b) Fb 1/EJ = 1/12 Fb^2/EJ$$

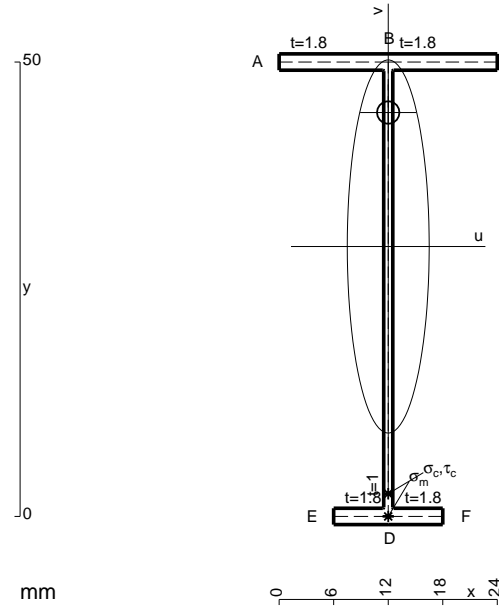

- A = 114.8 mm²
- J_u = 48377. mm⁴
- J_v = 2333. mm⁴
- J_i = 86.65 mm⁴
- y_o = 14.74 mm
- y_g = 29.7 mm
- T_y = -660. N
- M_x = -336600. Nmm
- x_m = 12. mm
- v_m = -29.7 mm
- σ_m = -Mv/J_u = -206.7 N/mm²
- y_c = 3. mm
- u_c = -12. mm
- v_c = -26.7 mm
- σ_c = -Mv/J_u = -206.7 N/mm²
- τ_c = TS'/tJ_u = 8.753 N/mm²
- τ_g = TS'/tJ_u = 8.753 N/mm²
- t_c = 330. mm
- σ_o = √σ²+3τ² = 207.2 N/mm²

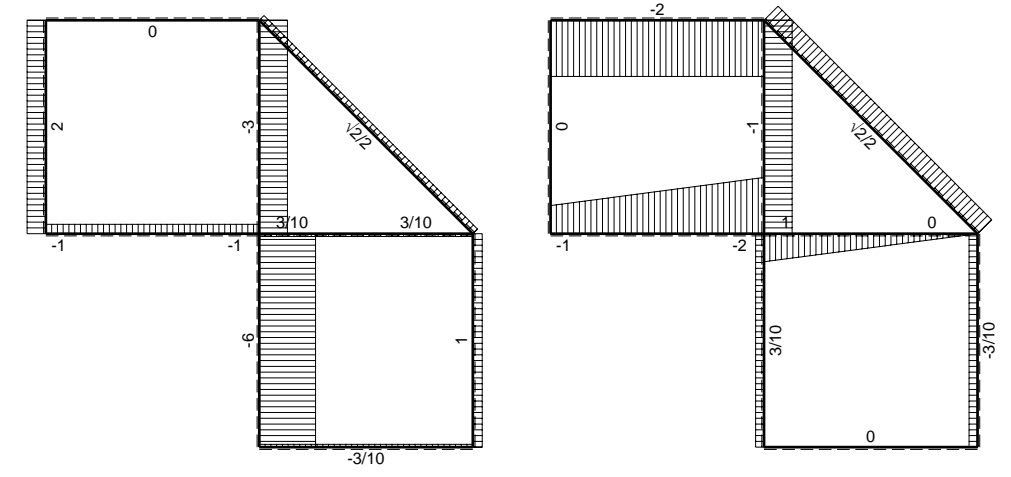
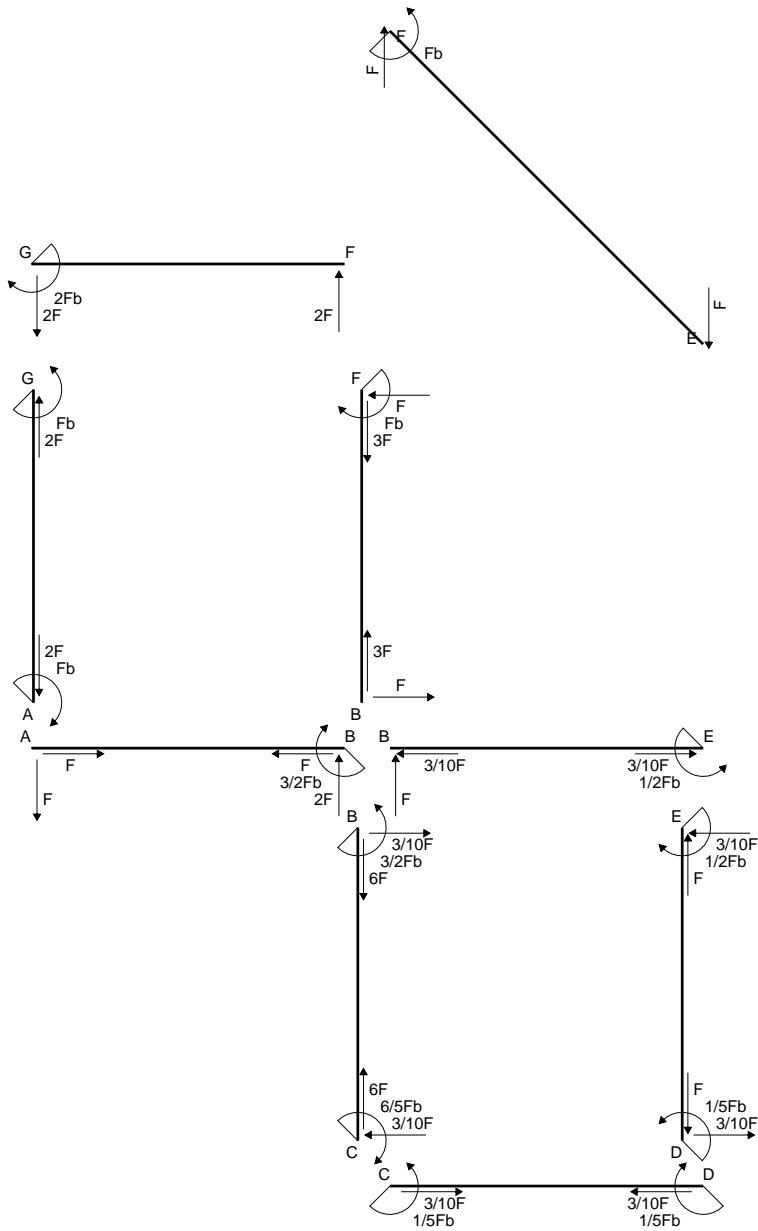

← (+) → F

↑ (+) ↓ F

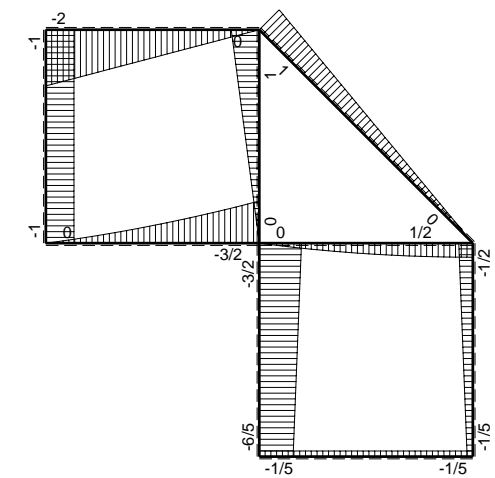

⊙ (+) ⊙ Fb

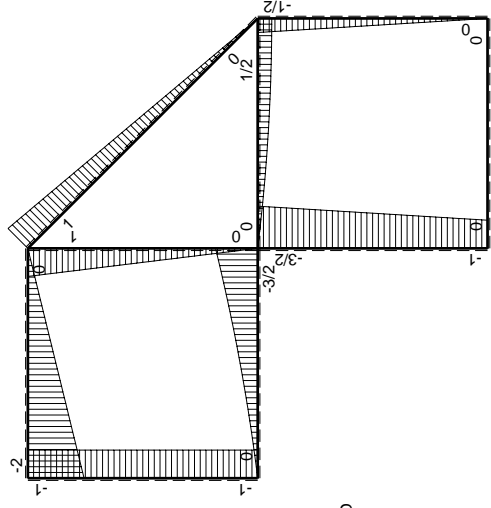
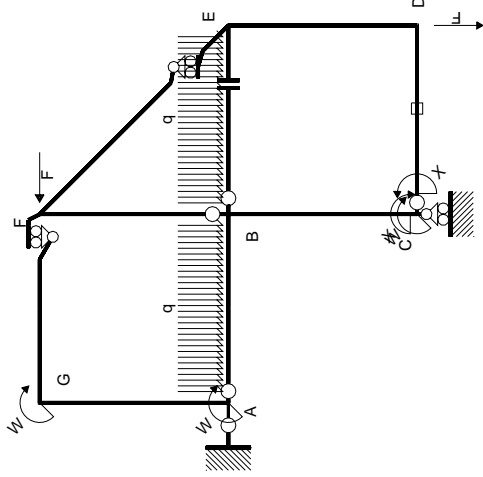

Schema di calcolo iperstatico

M_0 flessione da carichi assegnati

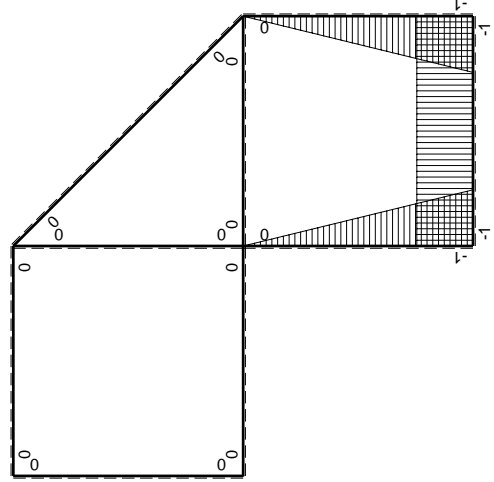

M_x flessione da iperstatica X=1

Quadro contribuiti PLV per iperstatica X=W_{cd}

→	$M_x(x)$	$M_0(x)$	$M_x M_0$	$M_x M_x$	$\int M_x M_0 / E J dx$	$\int X M_x M_x / E J dx$
AB b	0	$-Fx - 1/2qx^2$	0	0	0	0
BA b	0	$3/2Fb - 2Fx + 1/2qx^2$	0	0	0	0
BC b	$-x/b$	$-3/2Fb + 1/2Fx$	$3/2Fx - 1/2Fx^2 / b$	x^2 / b^2	$7/12Fb^2 / EJ$	$1/3Xb / EJ$
CB b	$1-x/b$	$Fb + 1/2Fx$	$Fb - 1/2Fx - 1/2Fx^2 / b$	$1 - 2x/b + x^2 / b^2$	0	0
CD b	-1	0	0	1	0	Xb / EJ
DC b	1	0	0	1	0	0
DE b	$-1+x/b$	$-1/2Fx$	$1/2Fx - 1/2Fx^2 / b$	$1 - 2x/b + x^2 / b^2$	$1/12Fb^2 / EJ$	$1/3Xb / EJ$
ED b	x/b	$1/2Fb - 1/2Fx$	$1/2Fx - 1/2Fx^2 / b$	x^2 / b^2	0	0
EF $\sqrt{2}b$	0	$\sqrt{2}/2Fx$	0	0	0	0
FG b	0	$-2Fx$	0	0	0	0
GF b	0	$2Fb - 2Fx$	0	0	0	0
GA b	0	$-Fb$	0	0	0	0
AG b	0	Fb	0	0	0	0
FB b	0	$Fb - Fx$	0	0	0	0
BF b	0	$-Fx$	0	0	0	0
BE b	0	$Fx - 1/2qx^2$	0	0	0	0
EB b	0	$-1/2Fb + 1/2qx^2$	0	0	0	0
CD	elongazione asta $N_{1,cd} \epsilon_{cd} L_{cd}$				$-Fb^2 / EJ$	
	totali				$-1/3Fb^2 / EJ$	$5/3Xb / EJ$
	iperstatica X=W _{cd}				$1/5Fb$	

Sviluppi di calcolo iperstatica

$$L_{BC}^{xx} = \int_0^b (x^2/b^2) 1/EJ dx = [1/3 x^3/b^2]_0^b 1/EJ$$

$$= (1/3 b) 1/EJ = 1/3 b/EJ$$

$$L_{CB}^{xx} = \int_0^b (1 - 2x/b + x^2/b^2) 1/EJ dx = [x - x^2/b + 1/3 x^3/b^2]_0^b 1/EJ$$

$$= (b - b + 1/3 b) 1/EJ = 1/3 b/EJ$$

$$L_{CD}^{xx} = \int_0^b (1) 1/EJ dx = [x]_0^b 1/EJ$$

$$= (b) 1/EJ = b/EJ$$

$$L_{DC}^{xx} = \int_0^b (1) 1/EJ dx = [x]_0^b 1/EJ$$

$$= (b) 1/EJ = b/EJ$$

$$L_{DE}^{xx} = \int_0^b (1 - 2x/b + x^2/b^2) 1/EJ dx = [x - x^2/b + 1/3 x^3/b^2]_0^b 1/EJ$$

$$= (b - b + 1/3 b) 1/EJ = 1/3 b/EJ$$

$$L_{ED}^{xx} = \int_0^b (x^2/b^2) 1/EJ dx = [1/3 x^3/b^2]_0^b 1/EJ$$

$$= (1/3 b) 1/EJ = 1/3 b/EJ$$

$$L_{BC}^{x_0} = \int_0^b (3/2 x/b - 1/2 x^2/b^2) Fb 1/EJ dx = [3/4 x^2/b - 1/6 x^3/b^2]_0^b Fb 1/EJ$$

$$= (3/4 b - 1/6 b) Fb 1/EJ = 7/12 Fb^2/EJ$$

$$L_{CB}^{x_0} = \int_0^b (1 - 1/2 x/b - 1/2 x^2/b^2) Fb 1/EJ dx = [x - 1/4 x^2/b - 1/6 x^3/b^2]_0^b Fb 1/EJ$$

$$= (b - 1/4 b - 1/6 b) Fb 1/EJ = 7/12 Fb^2/EJ$$

$$L_{DE}^{x_0} = \int_0^b (1/2 x/b - 1/2 x^2/b^2) Fb 1/EJ dx = [1/4 x^2/b - 1/6 x^3/b^2]_0^b Fb 1/EJ$$

$$= (1/4 b - 1/6 b) Fb 1/EJ = 1/12 Fb^2/EJ$$

$$L_{ED}^{x_0} = \int_0^b (1/2 x/b - 1/2 x^2/b^2) Fb 1/EJ dx = [1/4 x^2/b - 1/6 x^3/b^2]_0^b Fb 1/EJ$$

$$= (1/4 b - 1/6 b) Fb 1/EJ = 1/12 Fb^2/EJ$$

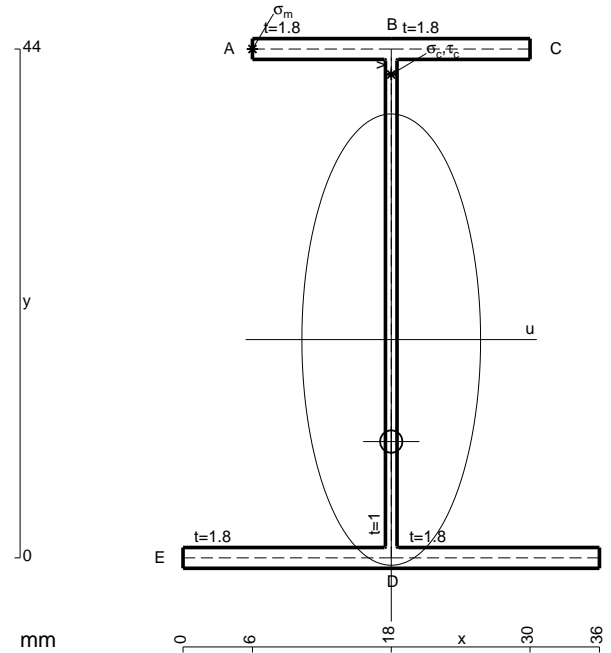

- A = 152. mm²
- J_u = 57885. mm⁴
- J_v = 9072. mm⁴
- J_i = 131.3 mm⁴
- y_o = -8.817 mm
- y_g = 18.87 mm
- T_y = -1000. N
- M_x = -500000. Nmm
- x_m = 6. mm
- y_m = 44. mm
- u_m = -12. mm
- v_m = 25.13 mm
- σ_m = -M_y/J_u = 217. N/mm²
- x_c = 18. mm
- y_c = 44. mm
- v_c = 25.13 mm
- σ_c = -M_y/J_u = 217. N/mm²
- τ_c = T_S/tJ_u = 18.75 N/mm²
- τ_g = T_S/tJ_u = 18.75 N/mm²
- t_c = 500. mm
- σ_o = √(σ²+3τ²) = 219.5 N/mm²

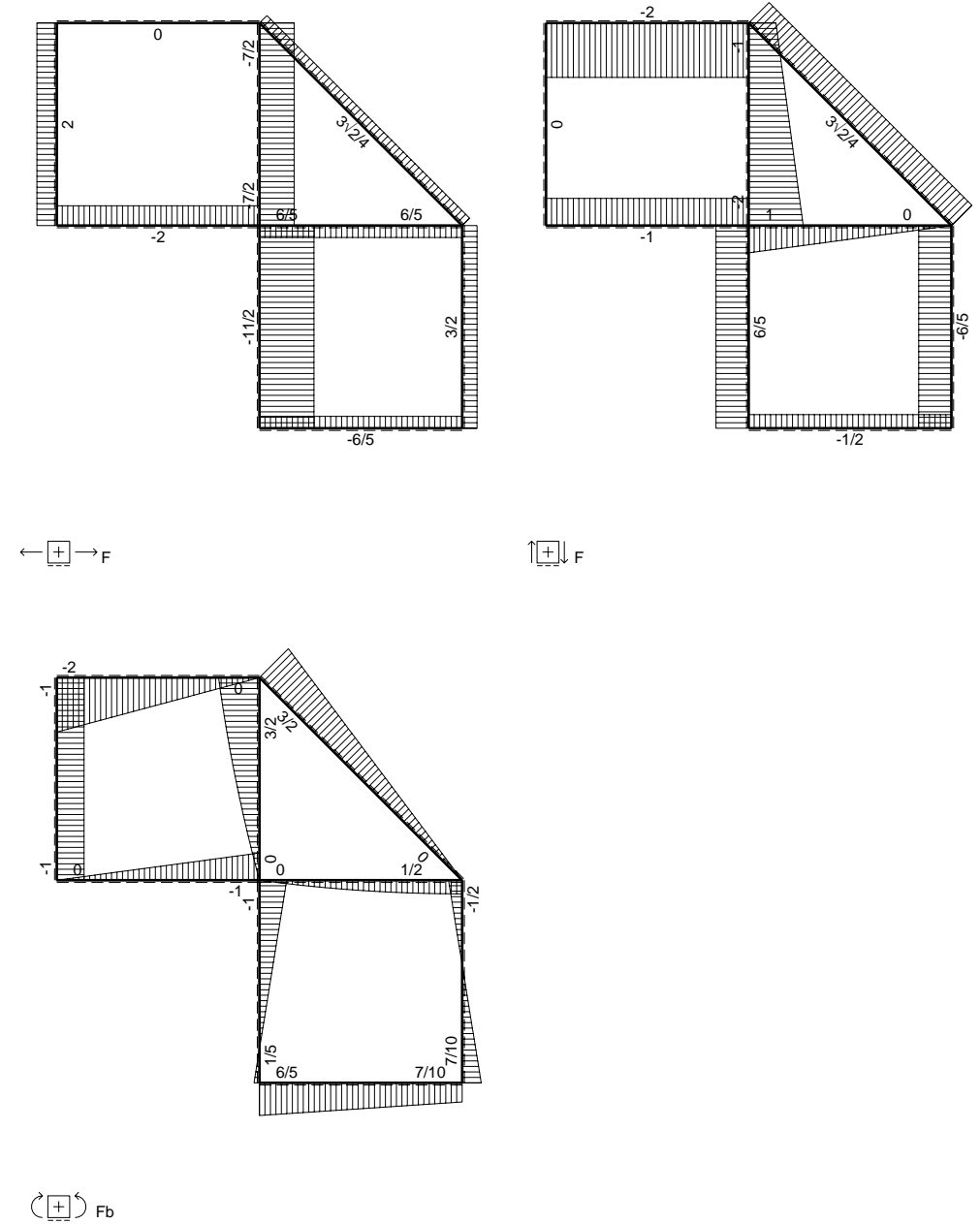
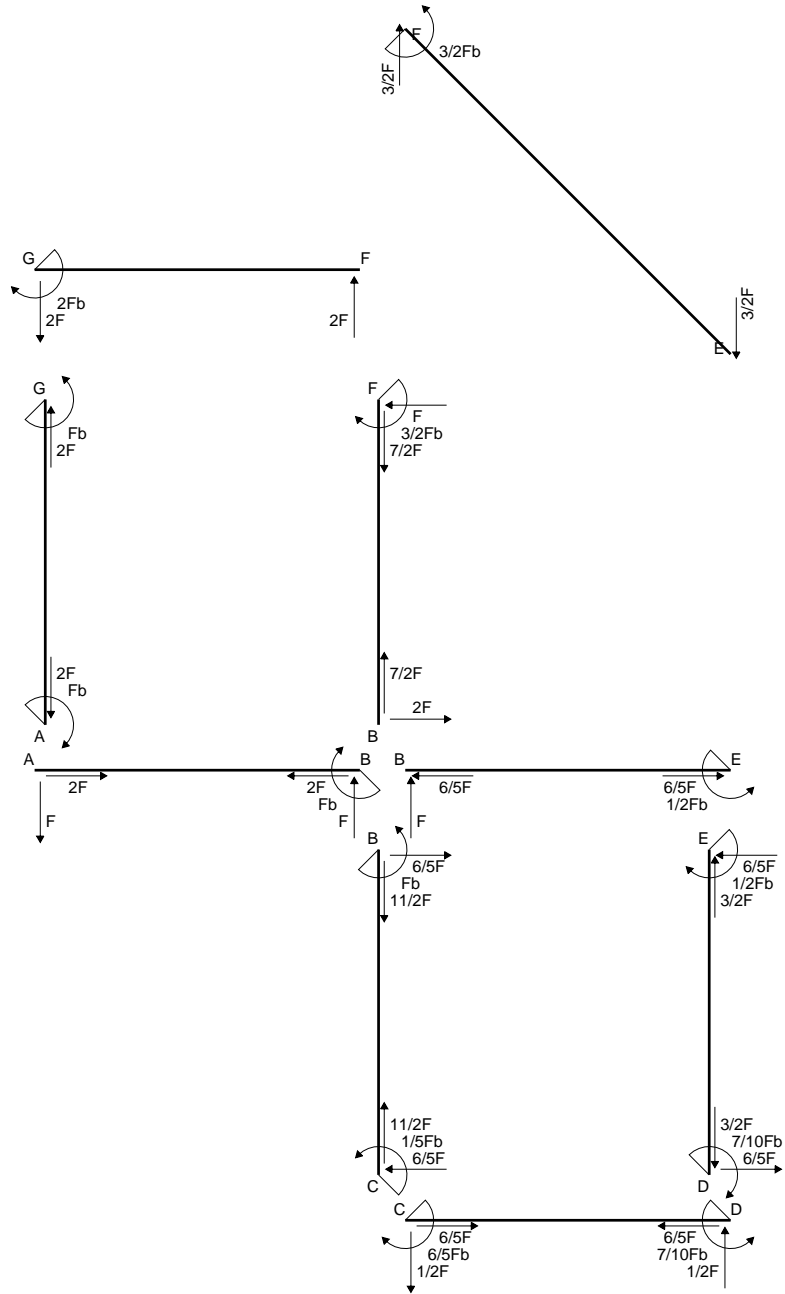

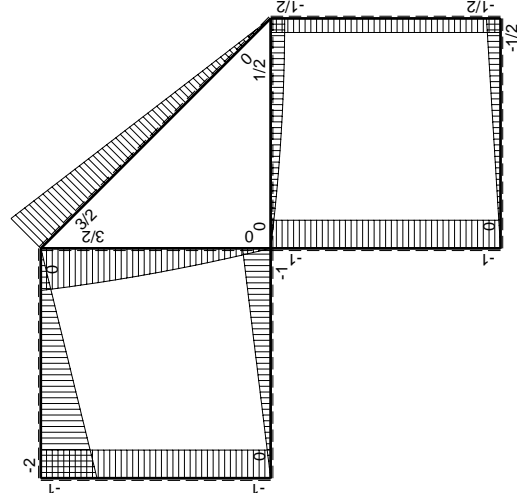
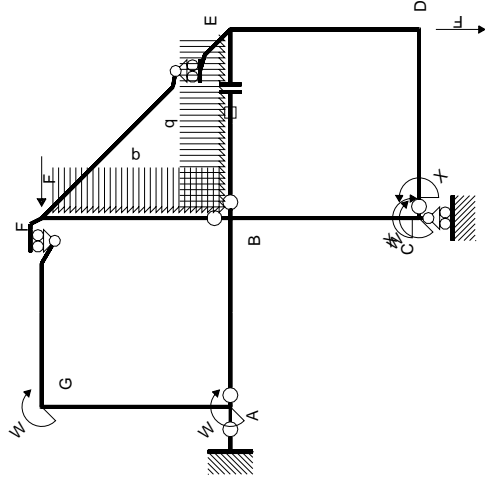

Schema di calcolo iperstatico

M_0 flessione da carichi assegnati

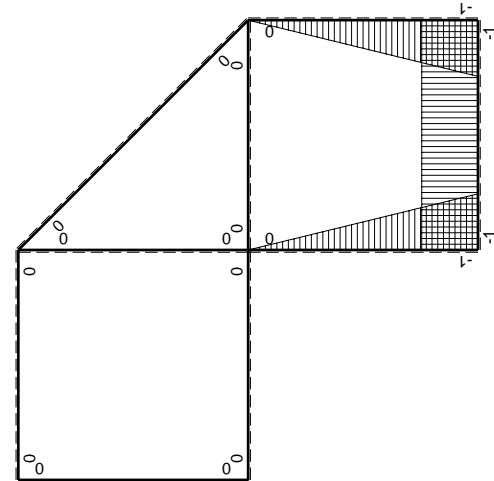

M_x flessione da iperstatica X=1

Quadro contribuiti PLV per iperstatica X=W_{cd}

→	$M_x(x)$	$M_0(x)$	$M_x M_0$	$M_x M_x$	$\int M_x M_0 / EJ dx$	$\int M_x M_x / EJ dx$
AB b	0	-Fx	0	0	0	0
BA b	0	Fb-Fx	0	0	0	0
BC b	-x/b	-Fb	Fx	x^2/b^2	$1/2 Fb^2/EJ$	$1/3 Xb/EJ$
CB b	1-x/b	Fb	Fb-Fx	$1-2x/b+x^2/b^2$	$1/2 Fb^2/EJ$	$1/3 Xb/EJ$
CD b	-1	-1/2Fx	1/2Fx	1	$1/4 Fb^2/EJ$	Xb/EJ
DC b	1	1/2Fb-1/2Fx	1/2Fb-1/2Fx	1	$1/4 Fb^2/EJ$	Xb/EJ
DE b	-1+x/b	-1/2Fb	1/2Fb-1/2Fx	$1-2x/b+x^2/b^2$	$1/4 Fb^2/EJ$	$1/3 Xb/EJ$
ED b	x/b	1/2Fb	1/2Fx	x^2/b^2	$1/4 Fb^2/EJ$	$1/3 Xb/EJ$
EF $\sqrt{2}b$	0	$3\sqrt{2}/4Fx$	0	0	0	0
FG b	0	-2Fx	0	0	0	0
GF b	0	2Fb-2Fx	0	0	0	0
GA b	0	-Fb	0	0	0	0
AG b	0	Fb	0	0	0	0
FB b	0	$3/2Fb-Fx-1/2qx^2$	0	0	0	0
BF b	0	$-2Fx+1/2qx^2$	0	0	0	0
BE b	0	$Fx-1/2qx^2$	0	0	0	0
EB b	0	$-1/2Fb+1/2qx^2$	0	0	0	0
BE	elongazione asta $N_{1, BE}^E - L_{BE}^E$				Fb^2/EJ	
	totali				$2Fb^2/EJ$	$5/3 Xb/EJ$
	iperstatica X=W _{cd}				$-6/5 Fb$	

Sviluppi di calcolo iperstatica

$$L_{BC}^{xx} = \int_0^b (x^2/b^2) 1/EJ dx = [1/3 x^3/b^2]_0^b 1/EJ$$

$$= (1/3 b) 1/EJ = 1/3 b/EJ$$

$$L_{CB}^{xx} = \int_0^b (1 - 2x/b + x^2/b^2) 1/EJ dx = [x - x^2/b + 1/3 x^3/b^2]_0^b 1/EJ$$

$$= (b - b + 1/3 b) 1/EJ = 1/3 b/EJ$$

$$L_{CD}^{xx} = \int_0^b (1) 1/EJ dx = [x]_0^b 1/EJ$$

$$= (b) 1/EJ = b/EJ$$

$$L_{DC}^{xx} = \int_0^b (1) 1/EJ dx = [x]_0^b 1/EJ$$

$$= (b) 1/EJ = b/EJ$$

$$L_{DE}^{xx} = \int_0^b (1 - 2x/b + x^2/b^2) 1/EJ dx = [x - x^2/b + 1/3 x^3/b^2]_0^b 1/EJ$$

$$= (b - b + 1/3 b) 1/EJ = 1/3 b/EJ$$

$$L_{ED}^{xx} = \int_0^b (x^2/b^2) 1/EJ dx = [1/3 x^3/b^2]_0^b 1/EJ$$

$$= (1/3 b) 1/EJ = 1/3 b/EJ$$

$$L_{BC}^{xo} = \int_0^b (x/b) Fb 1/EJ dx = [1/2 x^2/b]_0^b Fb 1/EJ$$

$$= (1/2 b) Fb 1/EJ = 1/2 Fb^2/EJ$$

$$L_{CB}^{xo} = \int_0^b (1 - x/b) Fb 1/EJ dx = [x - 1/2 x^2/b]_0^b Fb 1/EJ$$

$$= (b - 1/2 b) Fb 1/EJ = 1/2 Fb^2/EJ$$

$$L_{CD}^{xo} = \int_0^b (1/2 x/b) Fb 1/EJ dx = [1/4 x^2/b]_0^b Fb 1/EJ$$

$$= (1/4 b) Fb 1/EJ = 1/4 Fb^2/EJ$$

$$L_{DC}^{xo} = \int_0^b (1/2 - 1/2 x/b) Fb 1/EJ dx = [1/2 x - 1/4 x^2/b]_0^b Fb 1/EJ$$

$$= (1/2 b - 1/4 b) Fb 1/EJ = 1/4 Fb^2/EJ$$

$$L_{DE}^{xo} = \int_0^b (1/2 - 1/2 x/b) Fb 1/EJ dx = [1/2 x - 1/4 x^2/b]_0^b Fb 1/EJ$$

$$= (1/2 b - 1/4 b) Fb 1/EJ = 1/4 Fb^2/EJ$$

$$L_{ED}^{xo} = \int_0^b (1/2 x/b) Fb 1/EJ dx = [1/4 x^2/b]_0^b Fb 1/EJ$$

$$= (1/4 b) Fb 1/EJ = 1/4 Fb^2/EJ$$

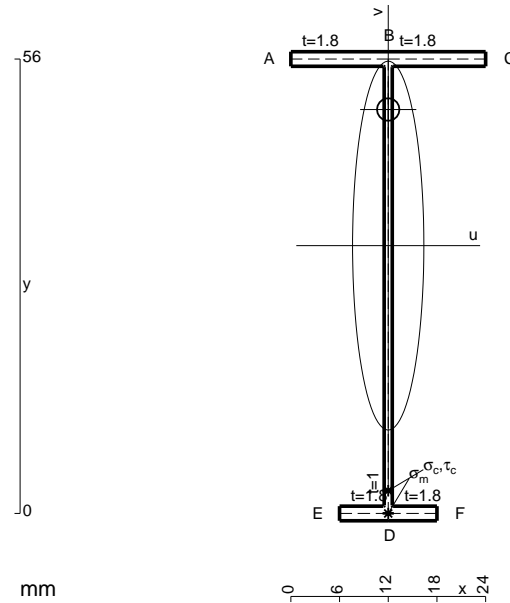

$A = 120.8 \text{ mm}^2$
 $J_u = 62410. \text{ mm}^4$
 $J_v = 2333. \text{ mm}^4$
 $J_t = 88.65 \text{ mm}^4$
 $y_o = 16.77 \text{ mm}$
 $y_g = 33.01 \text{ mm}$
 $T_y = -620. \text{ N}$
 $M_x = -421600. \text{ Nmm}$
 $x_m = 12. \text{ mm}$
 $v_m = -33.01 \text{ mm}$
 $\sigma_m = -Mv/J_u = -223. \text{ N/mm}^2$
 $y_c = 3. \text{ mm}$
 $u_c = -12. \text{ mm}$
 $v_c = -30.01 \text{ mm}$
 $\sigma_c = -Mv/J_u = -223. \text{ N/mm}^2$
 $\tau_c = TS'/tJ_u = 7.083 \text{ N/mm}^2$
 $\tau_g = TS'/tJ_u = 7.083 \text{ N/mm}^2$
 $t_c = 310. \text{ mm}$
 $\sigma_o = \sqrt{\sigma^2 + 3\tau^2} = 223.3 \text{ N/mm}^2$

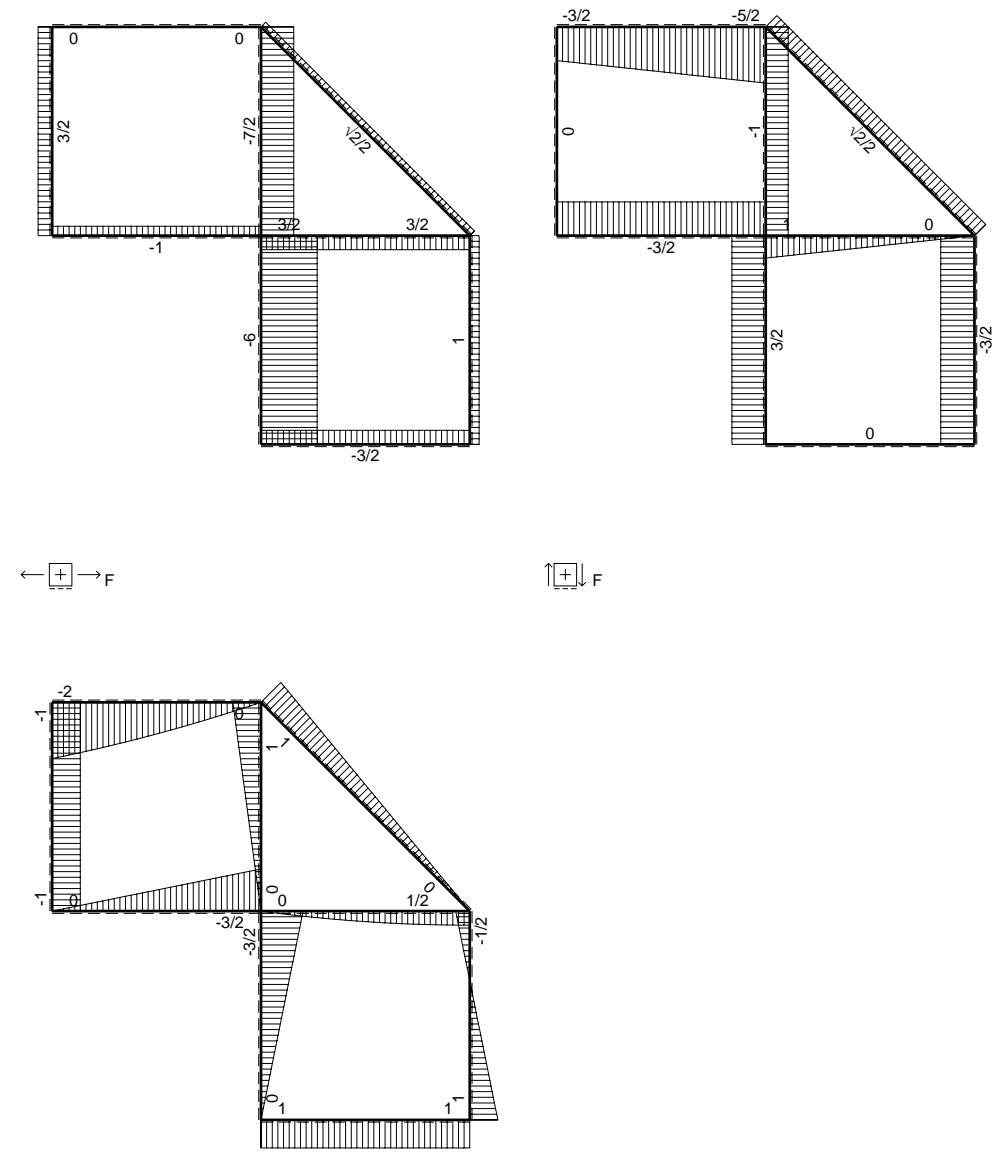
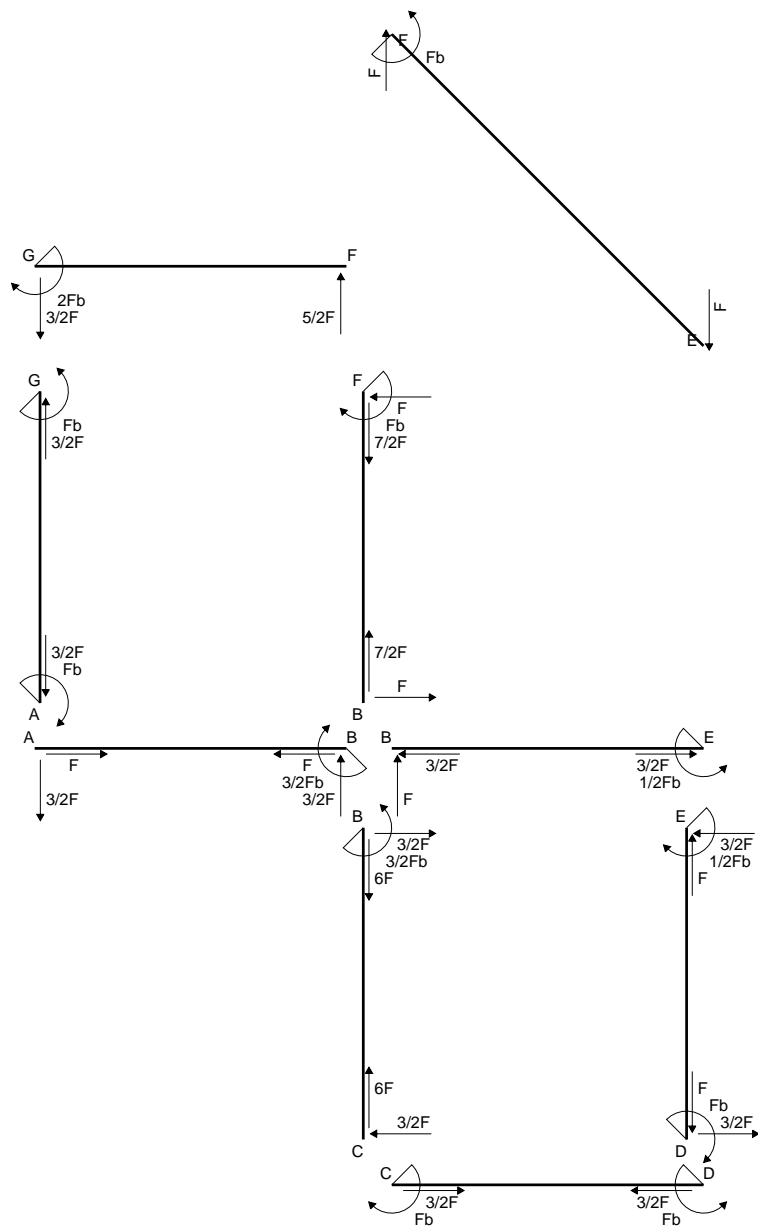

$\leftarrow \boxed{+} \rightarrow F_b$

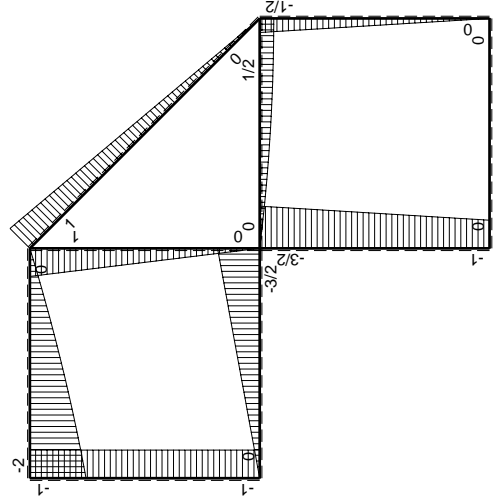
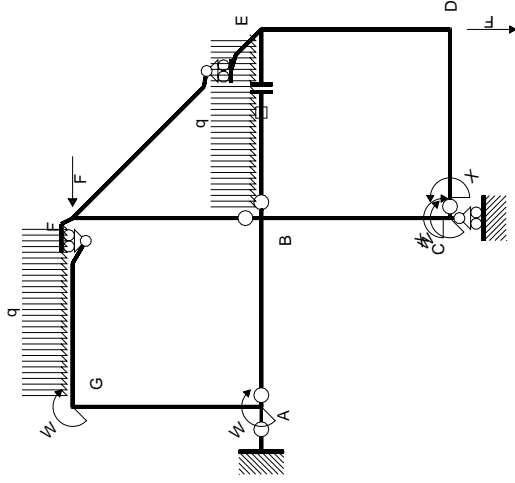

Schema di calcolo iperstatico

M_0 flessione da carichi assegnati

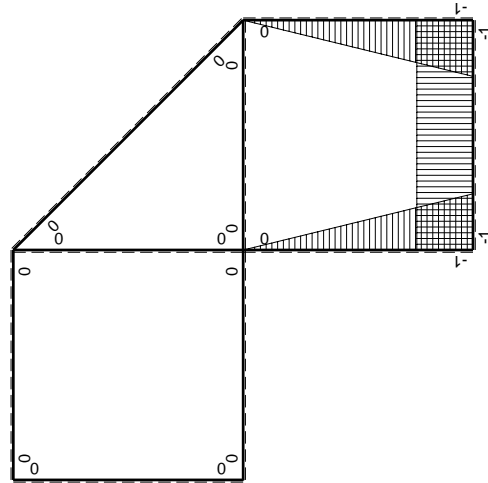

M_x flessione da iperstatica X=1

Quadro contribuiti PLV per iperstatica X=W_{CD}

→	$M_x(x)$	$M_0(x)$	$M_x M_0$	$M_x M_x$	$\int M_x M_0 / EJ dx$	$\int X M_x M_x / EJ dx$
AB b	0	-3/2Fx	0	0	0	0
BA b	0	3/2Fb-3/2Fx	0	0	0	0
BC b	-x/b	-3/2Fb+1/2Fx	3/2Fx-1/2Fx ² /b	x ² /b ²	7/12Fb ² /EJ	1/3Xb/EJ
CB b	1-x/b	Fb+1/2Fx	Fb-1/2Fx-1/2Fx ² /b	1-2x/b+x ² /b ²	0	Xb/EJ
CD b	-1	0	0	1	0	0
DC b	1	0	0	1	0	0
DE b	-1+x/b	-1/2Fx	1/2Fx-1/2Fx ² /b	1-2x/b+x ² /b ²	1/12Fb ² /EJ	1/3Xb/EJ
ED b	x/b	1/2Fb-1/2Fx	1/2Fx-1/2Fx ² /b	x ² /b ²	0	0
EF √2b	0	√2/2Fx	0	0	0	0
FG b	0	-5/2Fx+1/2qx ²	0	0	0	0
GF b	0	2Fb-3/2Fx-1/2qx ²	0	0	0	0
GA b	0	-Fb	0	0	0	0
AG b	0	Fb	0	0	0	0
FB b	0	Fb-Fx	0	0	0	0
BF b	0	-Fx	0	0	0	0
BE b	0	Fx-1/2qx ²	0	0	0	0
EB b	0	-1/2Fb+1/2qx ²	0	0	0	0
BE	elongazione asta $N_{1, BE}^{\epsilon_{BE} - BE}$			0	Fb ² /EJ	
	totali				5/3Fb ² /EJ	5/3Xb/EJ
	iperstatica X=W _{CD}				-Fb	

Sviluppi di calcolo iperstatica

$$L_{BC}^{xx} = \int_0^b (x^2/b^2) 1/EJ dx = [1/3 x^3/b^2]_0^b 1/EJ$$

$$= (1/3 b) 1/EJ = 1/3 b/EJ$$

$$L_{CB}^{xx} = \int_0^b (1 - 2x/b + x^2/b^2) 1/EJ dx = [x - x^2/b + 1/3 x^3/b^2]_0^b 1/EJ$$

$$= (b - b + 1/3 b) 1/EJ = 1/3 b/EJ$$

$$L_{CD}^{xx} = \int_0^b (1) 1/EJ dx = [x]_0^b 1/EJ$$

$$= (b) 1/EJ = b/EJ$$

$$L_{DC}^{xx} = \int_0^b (1) 1/EJ dx = [x]_0^b 1/EJ$$

$$= (b) 1/EJ = b/EJ$$

$$L_{DE}^{xx} = \int_0^b (1 - 2x/b + x^2/b^2) 1/EJ dx = [x - x^2/b + 1/3 x^3/b^2]_0^b 1/EJ$$

$$= (b - b + 1/3 b) 1/EJ = 1/3 b/EJ$$

$$L_{ED}^{xx} = \int_0^b (x^2/b^2) 1/EJ dx = [1/3 x^3/b^2]_0^b 1/EJ$$

$$= (1/3 b) 1/EJ = 1/3 b/EJ$$

$$L_{BC}^{xo} = \int_0^b (3/2 x/b - 1/2 x^2/b^2) Fb 1/EJ dx = [3/4 x^2/b - 1/6 x^3/b^2]_0^b Fb 1/EJ$$

$$= (3/4 b - 1/6 b) Fb 1/EJ = 7/12 Fb^2/EJ$$

$$L_{CB}^{xo} = \int_0^b (1 - 1/2 x/b - 1/2 x^2/b^2) Fb 1/EJ dx = [x - 1/4 x^2/b - 1/6 x^3/b^2]_0^b Fb 1/EJ$$

$$= (b - 1/4 b - 1/6 b) Fb 1/EJ = 7/12 Fb^2/EJ$$

$$L_{DE}^{xo} = \int_0^b (1/2 x/b - 1/2 x^2/b^2) Fb 1/EJ dx = [1/4 x^2/b - 1/6 x^3/b^2]_0^b Fb 1/EJ$$

$$= (1/4 b - 1/6 b) Fb 1/EJ = 1/12 Fb^2/EJ$$

$$L_{ED}^{xo} = \int_0^b (1/2 x/b - 1/2 x^2/b^2) Fb 1/EJ dx = [1/4 x^2/b - 1/6 x^3/b^2]_0^b Fb 1/EJ$$

$$= (1/4 b - 1/6 b) Fb 1/EJ = 1/12 Fb^2/EJ$$

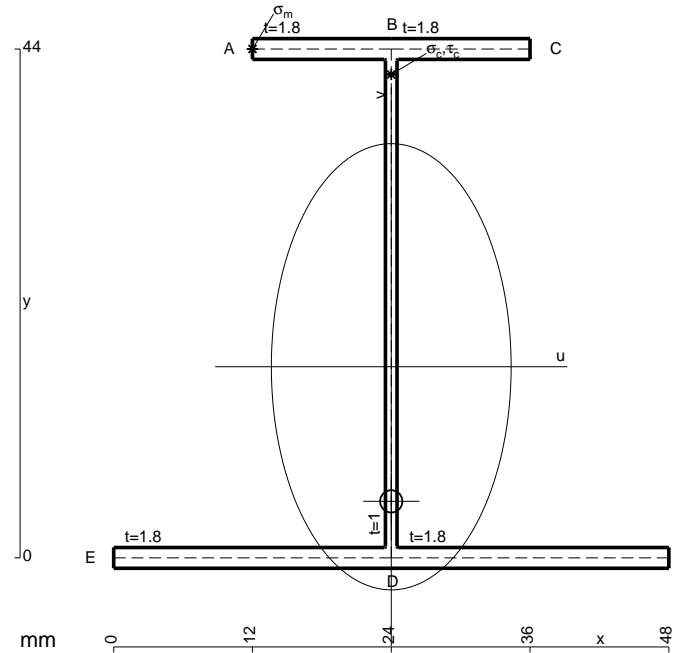

- A = 173.6 mm²
- J_u = 64622. mm⁴
- J_v = 18662. mm⁴
- J_i = 154.6 mm⁴
- y_o = -11.64 mm
- y_g = 16.53 mm
- T_y = -720. N
- M_x = -556800. Nmm
- x_m = 12. mm
- y_m = 44. mm
- u_m = -12. mm
- v_m = 27.47 mm
- σ_m = -Mv/J_u = 236.7 N/mm²
- x_c = 24. mm
- y_c = 44. mm
- v_c = 27.47 mm
- σ_c = -Mv/J_u = 236.7 N/mm²
- τ_c = TS'/tJ_u = 13.22 N/mm²
- τ_g = TS'/tJ_u = 13.22 N/mm²
- t_c = 480. mm
- σ_o = √σ²+3τ² = 237.8 N/mm²

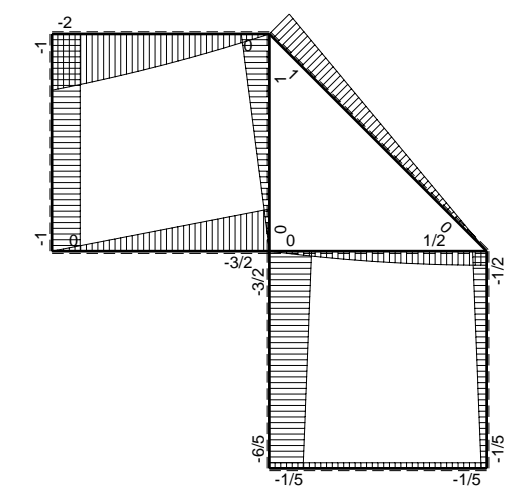
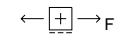
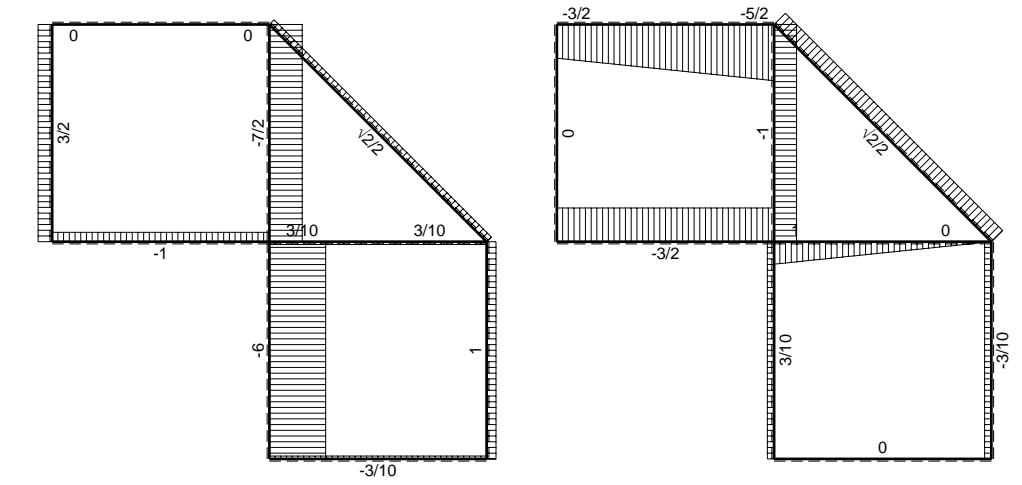
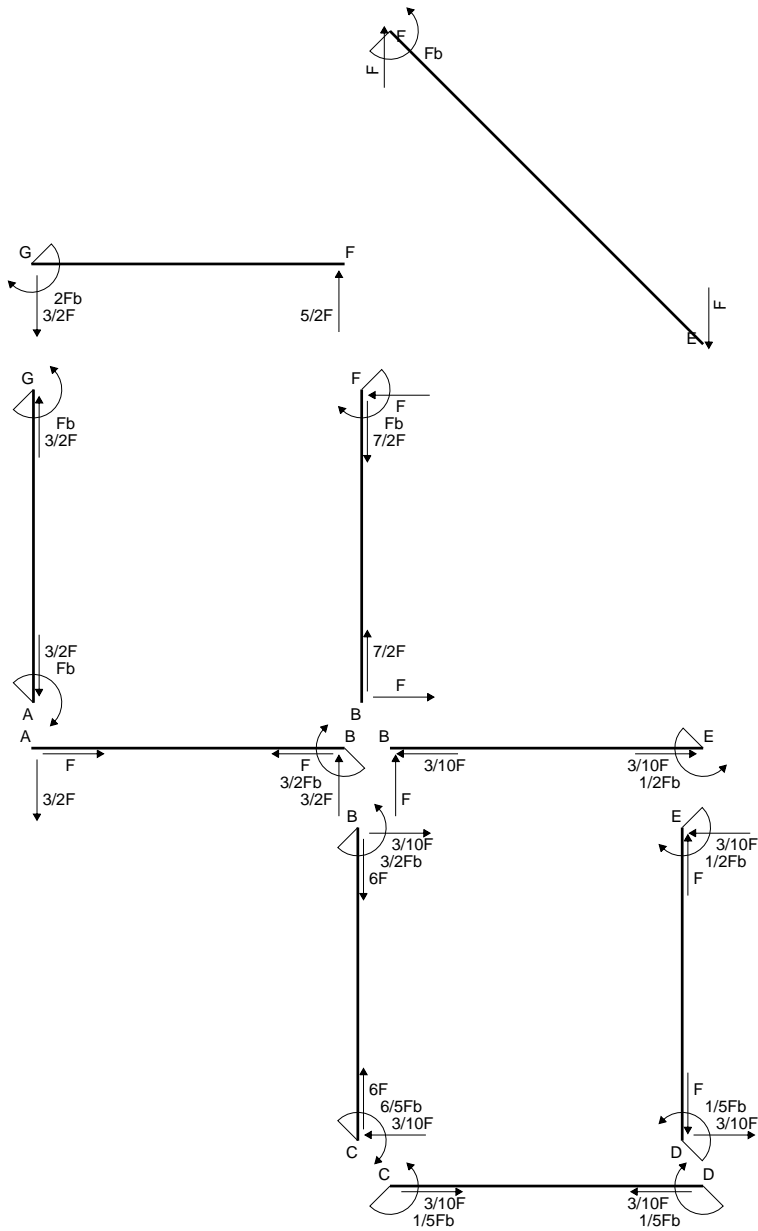

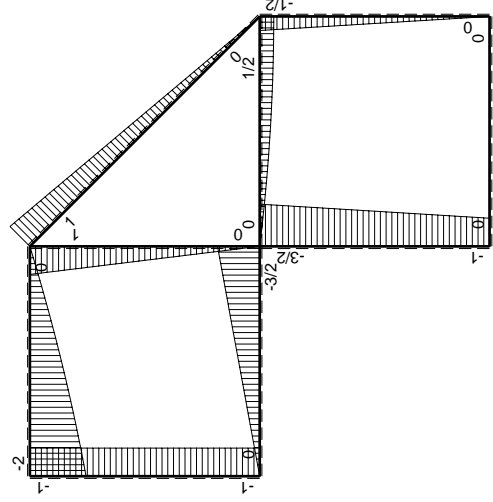
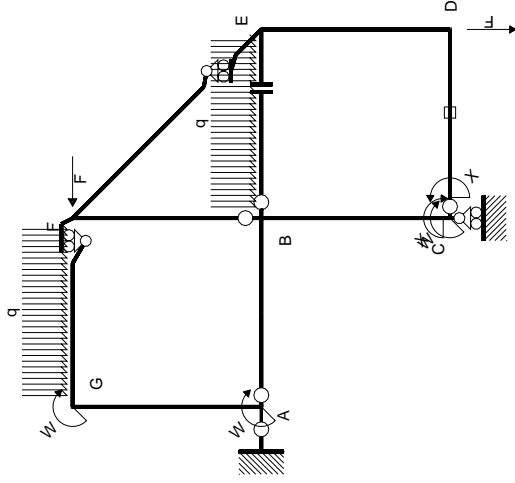

Schema di calcolo iperstatico

M_0 flessione da carichi assegnati

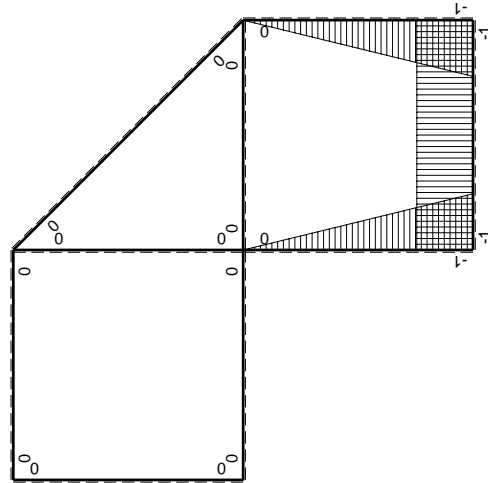

M_x flessione da iperstatica X=1

Quadro contribuiti PLV per iperstatica X=W_{cd}

→	$M_x(x)$	$M_0(x)$	$M_x M_0$	$M_x M_x$	$\int M_x M_0 / EJ dx$	$\int X M_x M_x / EJ dx$
AB b	0	-3/2Fx	0	0	0	0
BA b	0	3/2Fb-3/2Fx	0	0	0	0
BC b	-x/b	-3/2Fb+1/2Fx	3/2Fx-1/2Fx ² /b	x ² /b ²	7/12Fb ² /EJ	1/3Xb/EJ
CB b	1-x/b	Fb+1/2Fx	Fb-1/2Fx-1/2Fx ² /b	1-2x/b+x ² /b ²	0	Xb/EJ
CD b	-1	0	0	1	0	0
DC b	1	0	0	1	0	0
DE b	-1+x/b	-1/2Fx	1/2Fx-1/2Fx ² /b	1-2x/b+x ² /b ²	1/12Fb ² /EJ	1/3Xb/EJ
ED b	x/b	1/2Fb-1/2Fx	1/2Fx-1/2Fx ² /b	x ² /b ²	0	0
EF √2b	0	√2/2Fx	0	0	0	0
FG b	0	-5/2Fx+1/2qx ²	0	0	0	0
GF b	0	2Fb-3/2Fx-1/2qx ²	0	0	0	0
GA b	0	-Fb	0	0	0	0
AG b	0	Fb	0	0	0	0
FB b	0	Fb-Fx	0	0	0	0
BF b	0	-Fx	0	0	0	0
BE b	0	Fx-1/2qx ²	0	0	0	0
EB b	0	-1/2Fb+1/2qx ²	0	0	0	0
CD	elongazione asta $N_{1,cd} \epsilon_{cd} L_{cd}$				-Fb ² /EJ	
	totali				-1/3Fb ² /EJ	5/3Xb/EJ
	iperstatica X=W _{cd}				1/5Fb	

Sviluppi di calcolo iperstatica

$$L_{BC}^{xx} = \int_0^b (x^2/b^2) 1/EJ dx = [1/3 x^3/b^2]_0^b 1/EJ$$

$$= (1/3 b) 1/EJ = 1/3 b/EJ$$

$$L_{CB}^{xx} = \int_0^b (1 - 2x/b + x^2/b^2) 1/EJ dx = [x - x^2/b + 1/3 x^3/b^2]_0^b 1/EJ$$

$$= (b - b + 1/3 b) 1/EJ = 1/3 b/EJ$$

$$L_{CD}^{xx} = \int_0^b (1) 1/EJ dx = [x]_0^b 1/EJ$$

$$= (b) 1/EJ = b/EJ$$

$$L_{DC}^{xx} = \int_0^b (1) 1/EJ dx = [x]_0^b 1/EJ$$

$$= (b) 1/EJ = b/EJ$$

$$L_{DE}^{xx} = \int_0^b (1 - 2x/b + x^2/b^2) 1/EJ dx = [x - x^2/b + 1/3 x^3/b^2]_0^b 1/EJ$$

$$= (b - b + 1/3 b) 1/EJ = 1/3 b/EJ$$

$$L_{ED}^{xx} = \int_0^b (x^2/b^2) 1/EJ dx = [1/3 x^3/b^2]_0^b 1/EJ$$

$$= (1/3 b) 1/EJ = 1/3 b/EJ$$

$$L_{BC}^{xo} = \int_0^b (3/2 x/b - 1/2 x^2/b^2) Fb 1/EJ dx = [3/4 x^2/b - 1/6 x^3/b^2]_0^b Fb 1/EJ$$

$$= (3/4 b - 1/6 b) Fb 1/EJ = 7/12 Fb^2/EJ$$

$$L_{CB}^{xo} = \int_0^b (1 - 1/2 x/b - 1/2 x^2/b^2) Fb 1/EJ dx = [x - 1/4 x^2/b - 1/6 x^3/b^2]_0^b Fb 1/EJ$$

$$= (b - 1/4 b - 1/6 b) Fb 1/EJ = 7/12 Fb^2/EJ$$

$$L_{DE}^{xo} = \int_0^b (1/2 x/b - 1/2 x^2/b^2) Fb 1/EJ dx = [1/4 x^2/b - 1/6 x^3/b^2]_0^b Fb 1/EJ$$

$$= (1/4 b - 1/6 b) Fb 1/EJ = 1/12 Fb^2/EJ$$

$$L_{ED}^{xo} = \int_0^b (1/2 x/b - 1/2 x^2/b^2) Fb 1/EJ dx = [1/4 x^2/b - 1/6 x^3/b^2]_0^b Fb 1/EJ$$

$$= (1/4 b - 1/6 b) Fb 1/EJ = 1/12 Fb^2/EJ$$

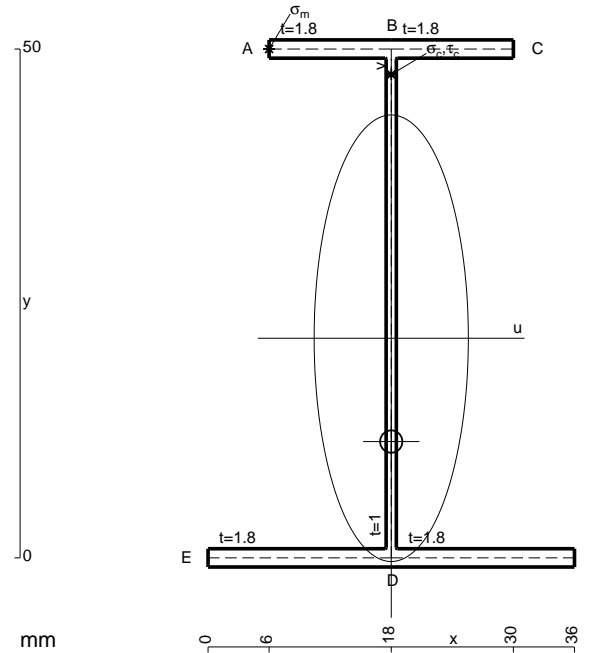

- A = 158. mm²
- J_u = 76071. mm⁴
- J_v = 9072. mm⁴
- J_i = 133.3 mm⁴
- y_o = -10.15 mm
- y_g = 21.58 mm
- T_y = -570. N
- M_x = -532000. Nmm
- x_m = 6. mm
- y_m = 50. mm
- u_m = -12. mm
- v_m = 28.42 mm
- σ_m = -M_y/J_u = 198.7 N/mm²
- x_c = 18. mm
- y_c = 50. mm
- v_c = 28.42 mm
- σ_c = -M_y/J_u = 198.7 N/mm²
- τ_c = T_S/tJ_u = 9.199 N/mm²
- τ_g = T_S/tJ_u = 9.199 N/mm²
- t_c = 380. mm
- σ_o = √(σ²+3τ²) = 199.4 N/mm²

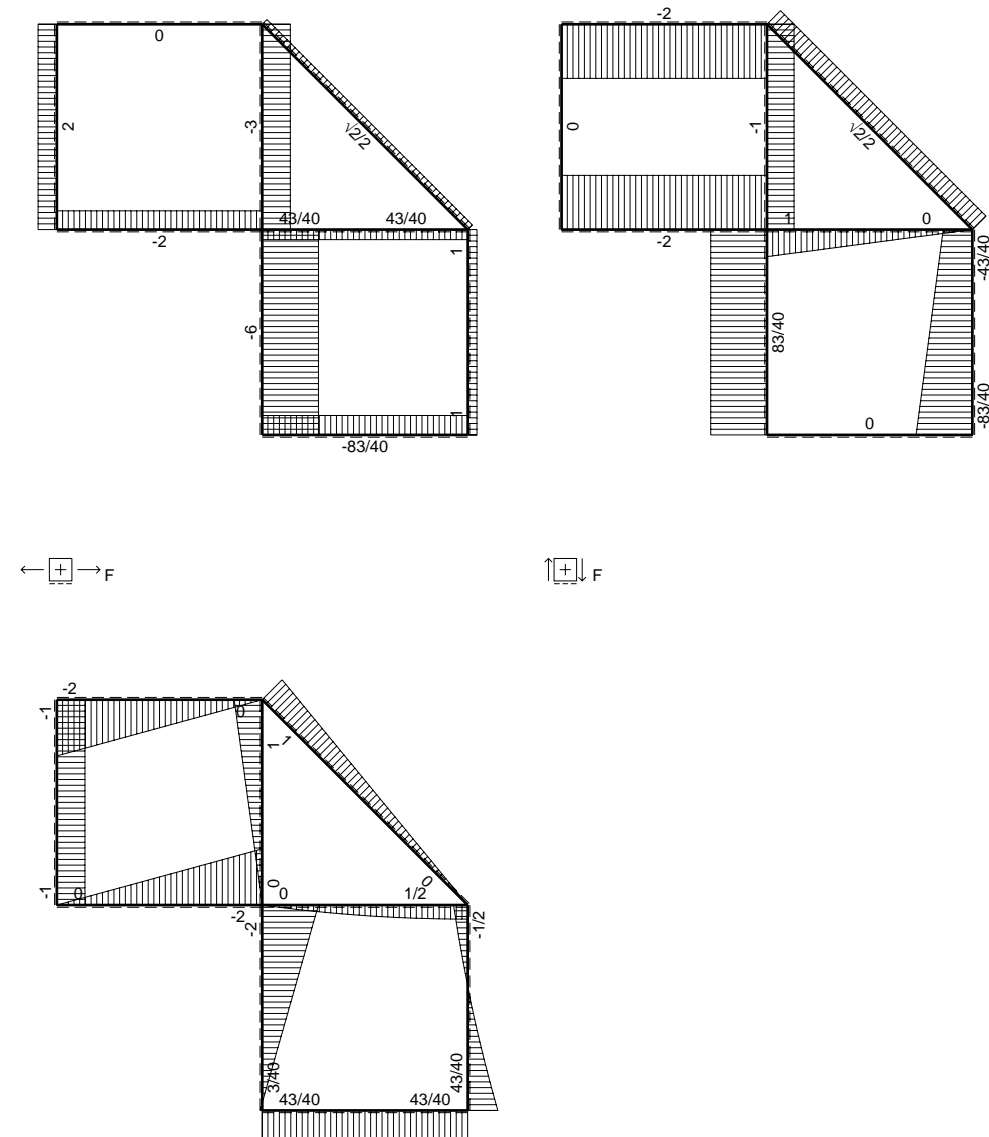
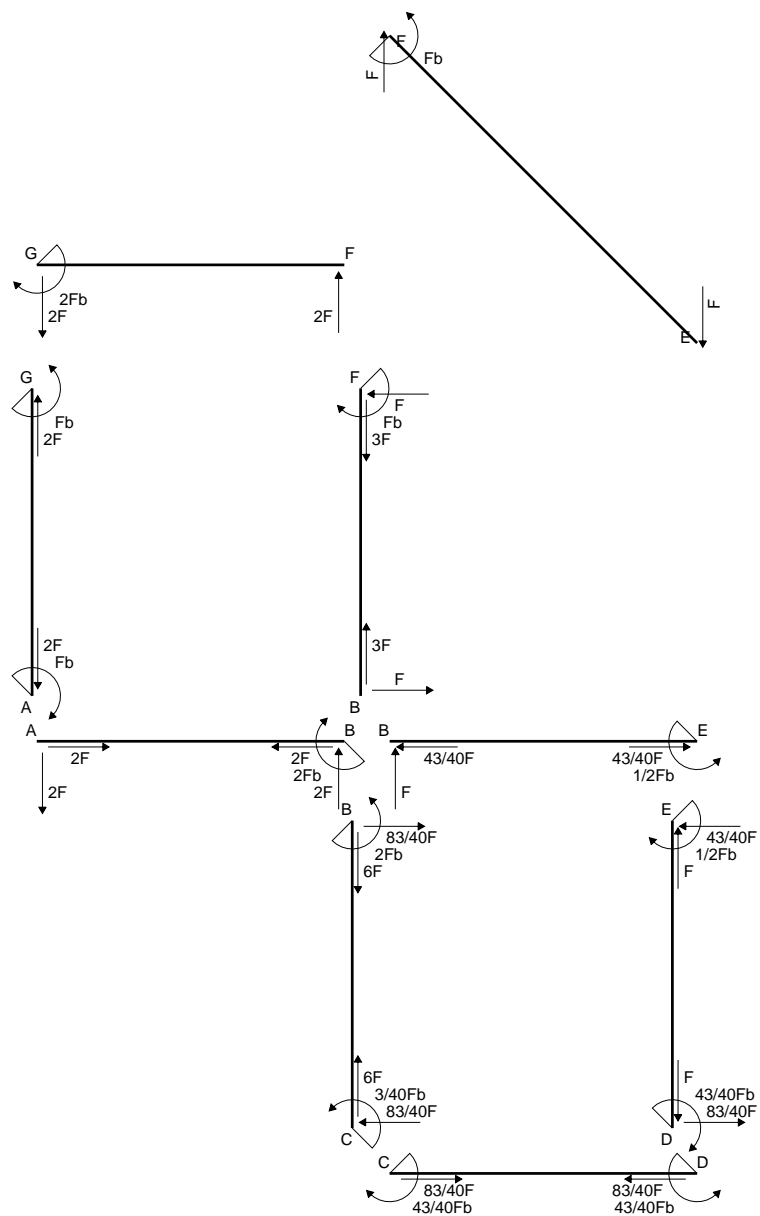

\oplus Fb

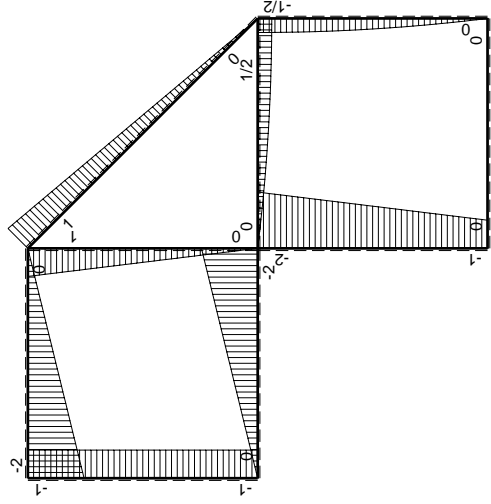
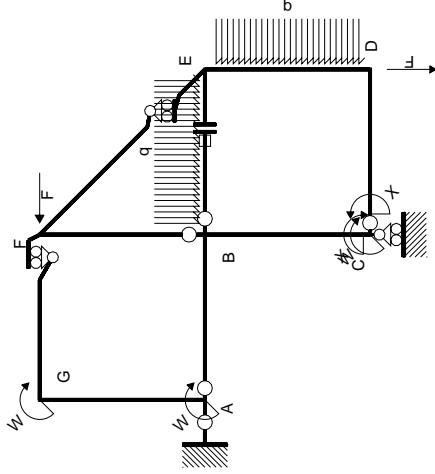

Schema di calcolo iperstatico

M_0 flessione da carichi assegnati

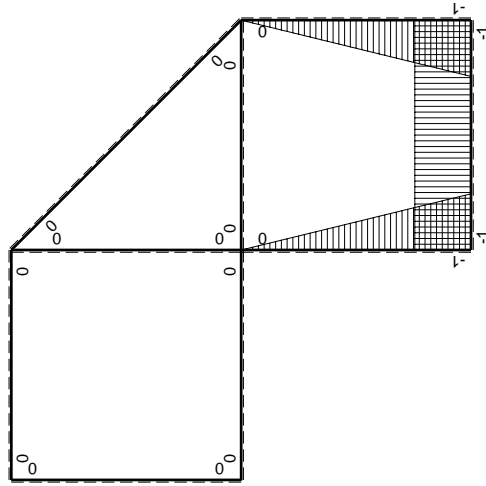

M_x flessione da iperstatica X=1

Quadro contribuiti PLV per iperstatica X=W_{CD}

→	$M_x(x)$	$M_0(x)$	$M_x M_0$	$M_x M_x$	$\int M_x M_0 / EJ dx$	$\int X M_x M_x / EJ dx$
AB b	0	-2Fx	0	0	0	0
BA b	0	2Fb-2Fx	0	0	0	0
BC b	-x/b	-2Fb+Fx	2Fx-Fx ² /b	x ² /b ²	2/3Fb ² /EJ	1/3Xb/EJ
CB b	1-x/b	Fb+Fx	Fb-Fx ² /b	1-2x/b+x ² /b ²	0	Xb/EJ
CD b	-1	0	0	1	0	0
DC b	1	0	0	1	0	0
DE b	-1+x/b	-Fx+1/2qx ²	Fx-3/2Fx ² /b+1/2qx ³ /b	1-2x/b+x ² /b ²	1/8Fb ² /EJ	1/3Xb/EJ
ED b	x/b	1/2Fb-1/2qx ²	1/2Fx-1/2qx ³ /b	x ² /b ²	0	0
EF √2b	0	√2/2Fx	0	0	0	0
FG b	0	-2Fx	0	0	0	0
GF b	0	2Fb-2Fx	0	0	0	0
GA b	0	-Fb	0	0	0	0
AG b	0	Fb	0	0	0	0
FB b	0	Fb-Fx	0	0	0	0
BF b	0	-Fx	0	0	0	0
BE b	0	Fx-1/2qx ²	0	0	0	0
EB b	0	-1/2Fb+1/2qx ²	0	0	0	0
BE	elongazione asta $N_{1, BE} \epsilon_{BE} = L_{BE}$				Fb ² /EJ	
	totali				43/24Fb ² /EJ	5/3Xb/EJ
	iperstatica X=W _{CD}				-43/40Fb	

Sviluppi di calcolo iperstatica

$$L_{BC}^{xx} = \int_0^b (x^2/b^2) 1/EJ dx = [1/3 x^3/b^2]_0^b 1/EJ$$

$$= (1/3 b) 1/EJ = 1/3 b/EJ$$

$$L_{CB}^{xx} = \int_0^b (1 - 2x/b + x^2/b^2) 1/EJ dx = [x - x^2/b + 1/3 x^3/b^2]_0^b 1/EJ$$

$$= (b - b + 1/3 b) 1/EJ = 1/3 b/EJ$$

$$L_{CD}^{xx} = \int_0^b (1) 1/EJ dx = [x]_0^b 1/EJ$$

$$= (b) 1/EJ = b/EJ$$

$$L_{DC}^{xx} = \int_0^b (1) 1/EJ dx = [x]_0^b 1/EJ$$

$$= (b) 1/EJ = b/EJ$$

$$L_{DE}^{xx} = \int_0^b (1 - 2x/b + x^2/b^2) 1/EJ dx = [x - x^2/b + 1/3 x^3/b^2]_0^b 1/EJ$$

$$= (b - b + 1/3 b) 1/EJ = 1/3 b/EJ$$

$$L_{ED}^{xx} = \int_0^b (x^2/b^2) 1/EJ dx = [1/3 x^3/b^2]_0^b 1/EJ$$

$$= (1/3 b) 1/EJ = 1/3 b/EJ$$

$$L_{BC}^{xo} = \int_0^b (2x/b - x^2/b^2) Fb 1/EJ dx = [x^2/b - 1/3 x^3/b^2]_0^b Fb 1/EJ$$

$$= (b - 1/3 b) Fb 1/EJ = 2/3 Fb^2/EJ$$

$$L_{CB}^{xo} = \int_0^b (1 - x^2/b^2) Fb 1/EJ dx = [x - 1/3 x^3/b^2]_0^b Fb 1/EJ$$

$$= (b - 1/3 b) Fb 1/EJ = 2/3 Fb^2/EJ$$

$$L_{DE}^{xo} = \int_0^b (x/b - 3/2 x^2/b^2 + 1/2 x^3/b^3) Fb 1/EJ dx = [1/2 x^2/b - 1/2 x^3/b^2 + 1/8 x^4/b^3]_0^b Fb 1/EJ$$

$$= (1/2 b - 1/2 b + 1/8 b) Fb 1/EJ = 1/8 Fb^2/EJ$$

$$L_{ED}^{xo} = \int_0^b (1/2 x/b - 1/2 x^3/b^3) Fb 1/EJ dx = [1/4 x^2/b - 1/8 x^4/b^3]_0^b Fb 1/EJ$$

$$= (1/4 b - 1/8 b) Fb 1/EJ = 1/8 Fb^2/EJ$$

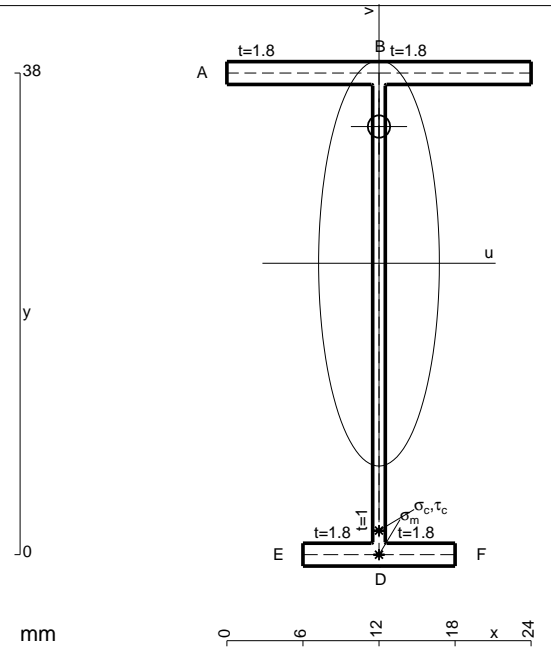

- A = 102.8 mm²
- J_u = 26327. mm⁴
- J_v = 2333. mm⁴
- J_I = 82.65 mm⁴
- y_o = 10.79 mm
- y_g = 22.99 mm
- N = -400. N
- T_y = -400. N
- M_x = -228000. Nmm
- x_m = 12. mm
- v_m = -22.99 mm
- σ_m = N/A-Mv/J_u = -203. N/mm²
- y_c = 3. mm
- u_c = -12. mm
- v_c = -19.99 mm
- σ_c = N/A-Mv/J_u = -203. N/mm²
- τ_c = TS_v/tJ_u = 7.546 N/mm²
- τ_g = TS_v/tJ_u = 7.546 N/mm²
- t_c = 200. mm
- σ_o = √σ²+3τ² = 203.4 N/mm²

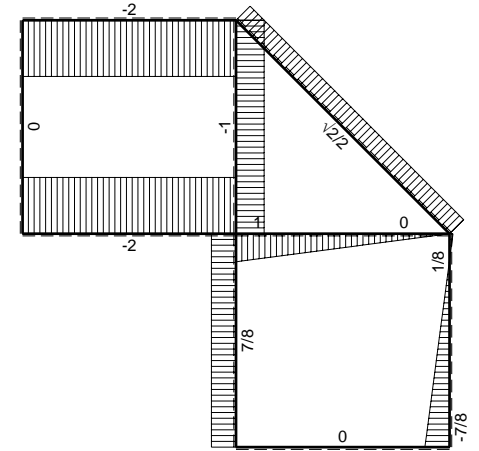
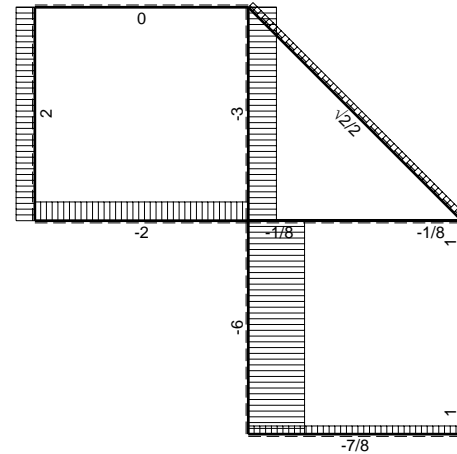
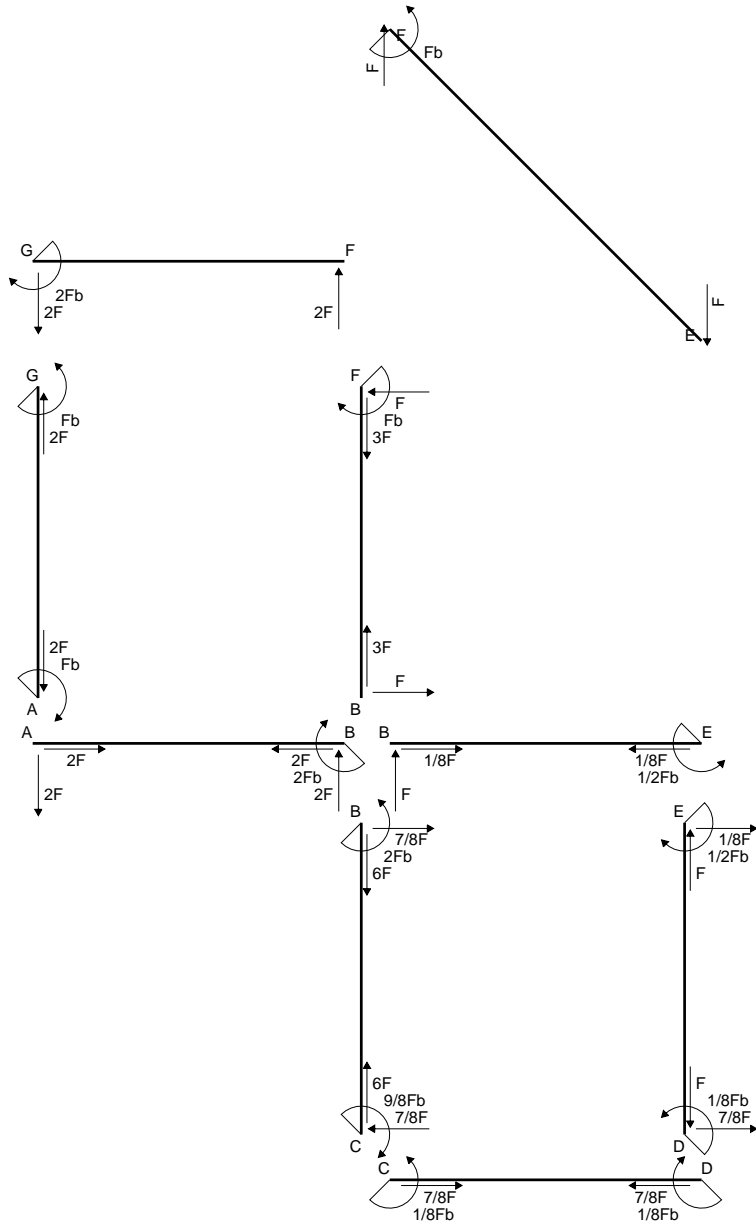

← ⊕ → F

↑ ⊕ ↓ F

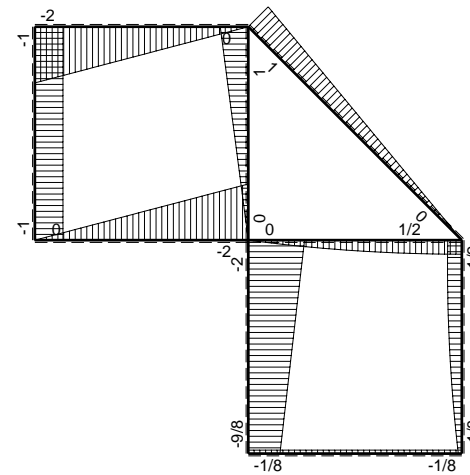

⊕ ⊖ F_b

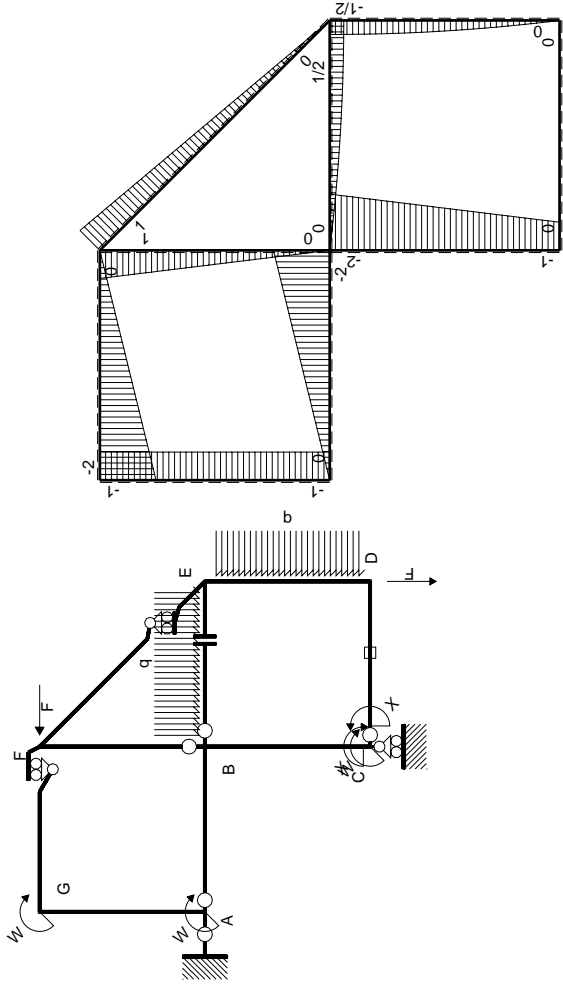

Schema di calcolo iperstatico

M_0 flessione da carichi assegnati

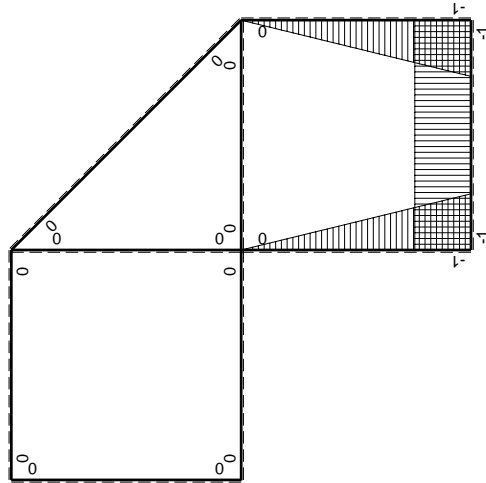

M_x flessione da iperstatica X=1

Quadro contribuiti PLV per iperstatica X=W_{CD}

→	$M_x(x)$	$M_0(x)$	$M_x M_0$	$M_x M_x$	$\int M_x M_0 / EJ dx$	$\int X M_x M_x / EJ dx$
AB b	0	-2Fx	0	0	0	0
BA b	0	2Fb-2Fx	0	0	0	0
BC b	-x/b	-2Fb+Fx	2Fx-Fx ² /b	x ² /b ²	2/3Fb ² /EJ	1/3Xb/EJ
CB b	1-x/b	Fb+Fx	Fb-Fx ² /b	1-2x/b+x ² /b ²	0	Xb/EJ
CD b	-1	0	0	1	0	0
DC b	1	0	0	1	0	0
DE b	-1+x/b	-Fx+1/2qx ²	Fx-3/2Fx ² /b+1/2qx ³ /b	1-2x/b+x ² /b ²	1/8Fb ² /EJ	1/3Xb/EJ
ED b	x/b	1/2Fb-1/2qx ²	1/2Fx-1/2qx ³ /b	x ² /b ²	0	0
EF $\sqrt{2}b$	0	$\sqrt{2}2Fx$	0	0	0	0
FG b	0	-2Fx	0	0	0	0
GF b	0	2Fb-2Fx	0	0	0	0
GA b	0	-Fb	0	0	0	0
AG b	0	Fb	0	0	0	0
FB b	0	Fb-Fx	0	0	0	0
BF b	0	-Fx	0	0	0	0
BE b	0	Fx-1/2qx ²	0	0	0	0
EB b	0	-1/2Fb+1/2qx ²	0	0	0	0
CD	elongazione asta $N_{1,cd} \epsilon_{cd} L_{cd}$				-Fb ² /EJ	
	totali				-5/24Fb ² /EJ	5/3Xb/EJ
	iperstatica X=W _{CD}				1/8Fb	

Sviluppi di calcolo iperstatica

$$L_{BC}^{xx} = \int_0^b (x^2/b^2) 1/EJ dx = [1/3 x^3/b^2]_0^b 1/EJ$$

$$= (1/3 b) 1/EJ = 1/3 b/EJ$$

$$L_{CB}^{xx} = \int_0^b (1 - 2x/b + x^2/b^2) 1/EJ dx = [x - x^2/b + 1/3 x^3/b^2]_0^b 1/EJ$$

$$= (b - b + 1/3 b) 1/EJ = 1/3 b/EJ$$

$$L_{CD}^{xx} = \int_0^b (1) 1/EJ dx = [x]_0^b 1/EJ$$

$$= (b) 1/EJ = b/EJ$$

$$L_{DC}^{xx} = \int_0^b (1) 1/EJ dx = [x]_0^b 1/EJ$$

$$= (b) 1/EJ = b/EJ$$

$$L_{DE}^{xx} = \int_0^b (1 - 2x/b + x^2/b^2) 1/EJ dx = [x - x^2/b + 1/3 x^3/b^2]_0^b 1/EJ$$

$$= (b - b + 1/3 b) 1/EJ = 1/3 b/EJ$$

$$L_{ED}^{xx} = \int_0^b (x^2/b^2) 1/EJ dx = [1/3 x^3/b^2]_0^b 1/EJ$$

$$= (1/3 b) 1/EJ = 1/3 b/EJ$$

$$L_{BC}^{x_0} = \int_0^b (2x/b - x^2/b^2) Fb 1/EJ dx = [x^2/b - 1/3 x^3/b^2]_0^b Fb 1/EJ$$

$$= (b - 1/3 b) Fb 1/EJ = 2/3 Fb^2/EJ$$

$$L_{CB}^{x_0} = \int_0^b (1 - x^2/b^2) Fb 1/EJ dx = [x - 1/3 x^3/b^2]_0^b Fb 1/EJ$$

$$= (b - 1/3 b) Fb 1/EJ = 2/3 Fb^2/EJ$$

$$L_{DE}^{x_0} = \int_0^b (x/b - 3/2 x^2/b^2 + 1/2 x^3/b^3) Fb 1/EJ dx = [1/2 x^2/b - 1/2 x^3/b^2 + 1/8 x^4/b^3]_0^b Fb 1/EJ$$

$$= (1/2 b - 1/2 b + 1/8 b) Fb 1/EJ = 1/8 Fb^2/EJ$$

$$L_{ED}^{x_0} = \int_0^b (1/2 x/b - 1/2 x^3/b^3) Fb 1/EJ dx = [1/4 x^2/b - 1/8 x^4/b^3]_0^b Fb 1/EJ$$

$$= (1/4 b - 1/8 b) Fb 1/EJ = 1/8 Fb^2/EJ$$

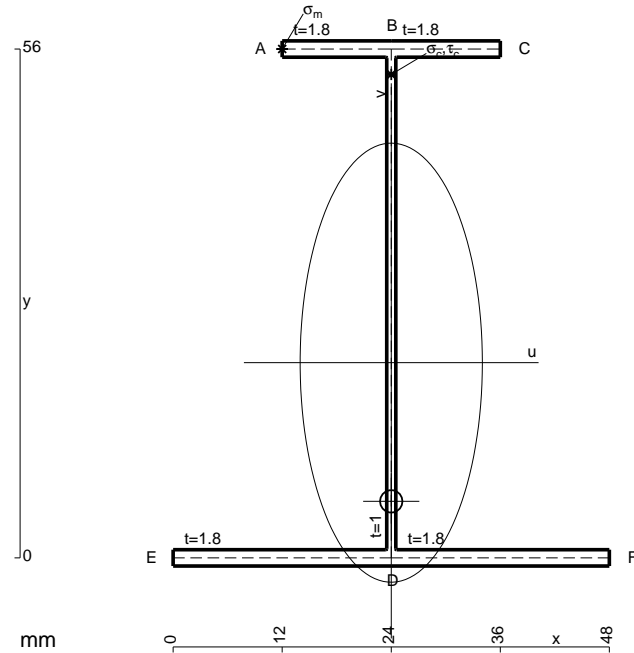

- A = 185.6 mm²
- J_u = 108358. mm⁴
- J_v = 18662. mm⁴
- J_i = 158.6 mm⁴
- y_o = -15.26 mm
- y_g = 21.48 mm
- T_y = -760. N
- M_x = -684000. Nmm
- x_m = 12. mm
- y_m = 56. mm
- u_m = -12. mm
- v_m = 34.52 mm
- σ_m = -M_y/J_u = 217.9 N/mm²
- x_c = 24. mm
- y_c = 56. mm
- v_c = 34.52 mm
- σ_c = -M_y/J_u = 217.9 N/mm²
- τ_c = T_S/tJ_u = 10.46 N/mm²
- τ_g = T_S/tJ_u = 10.46 N/mm²
- t_c = 380. mm
- σ_o = √σ²+3τ² = 218.6 N/mm²

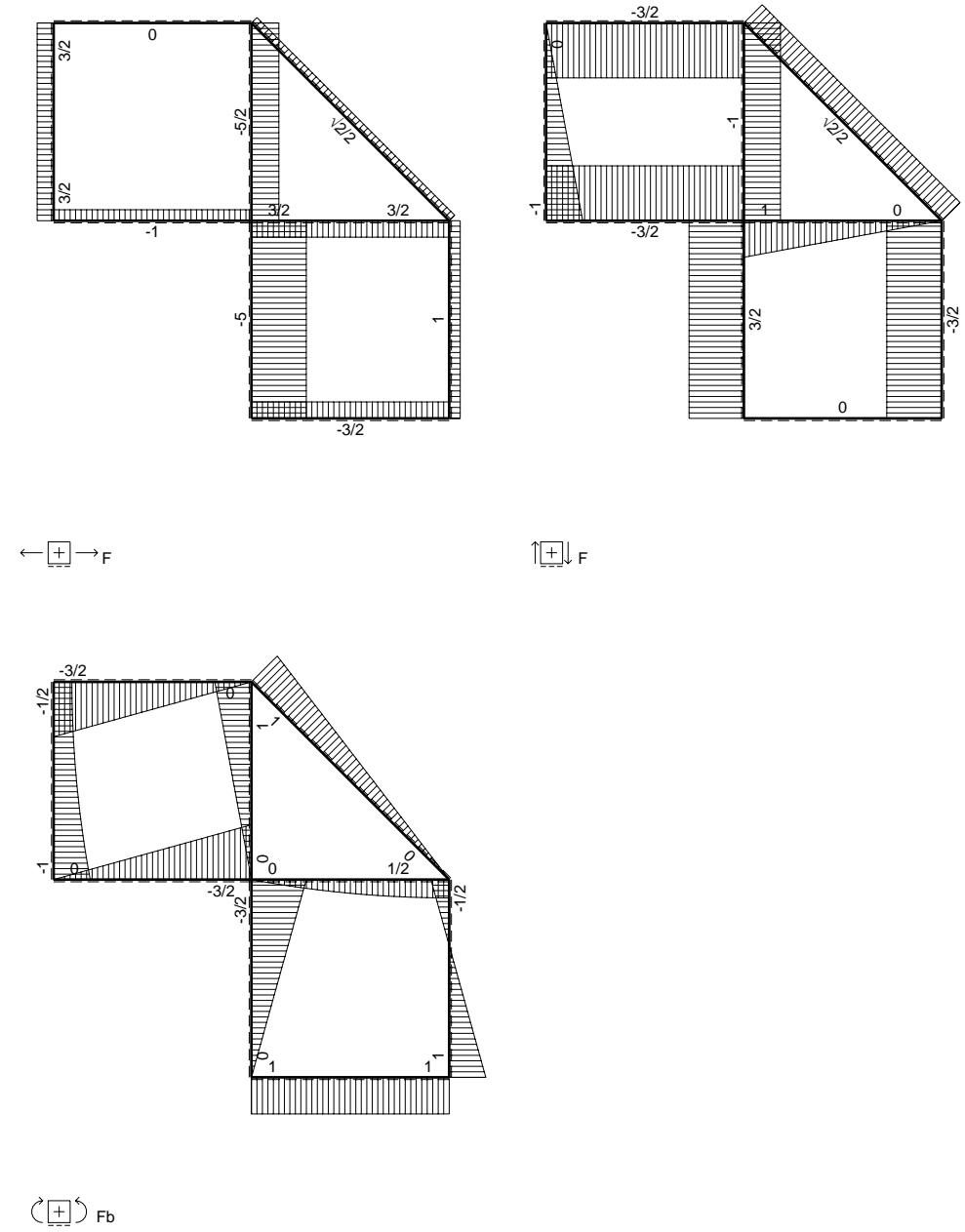
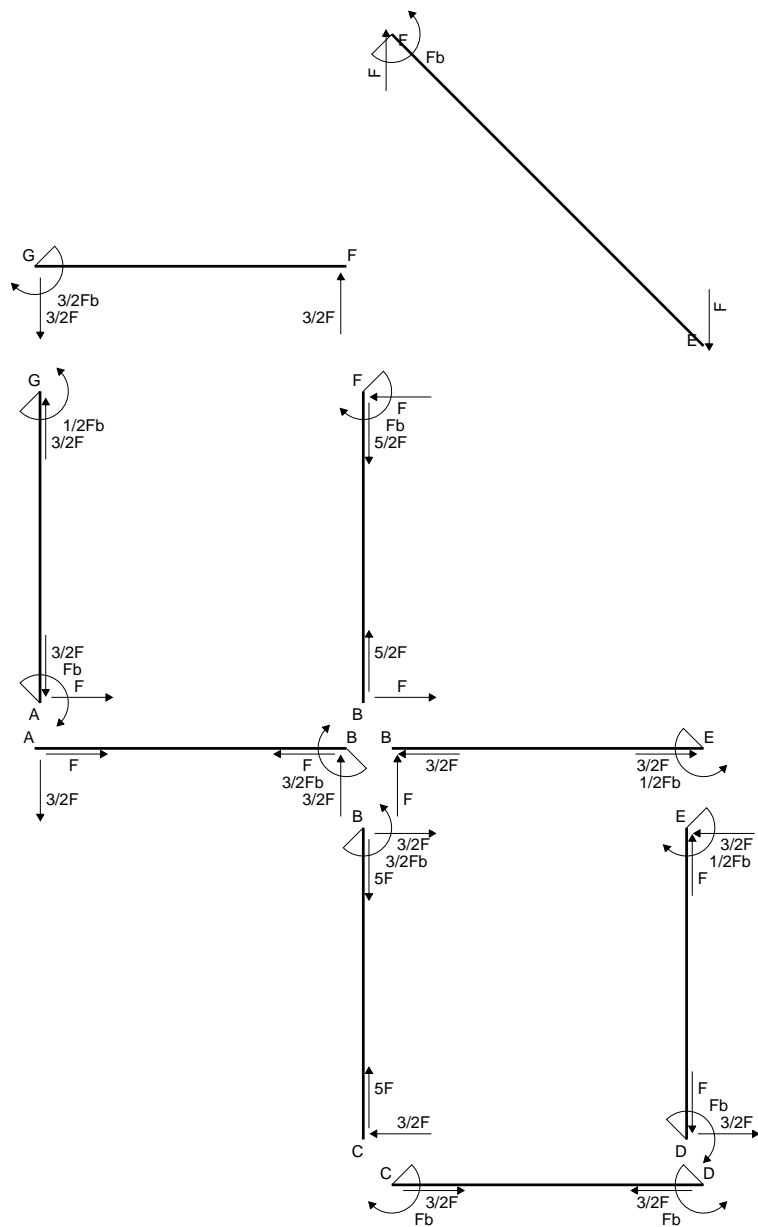

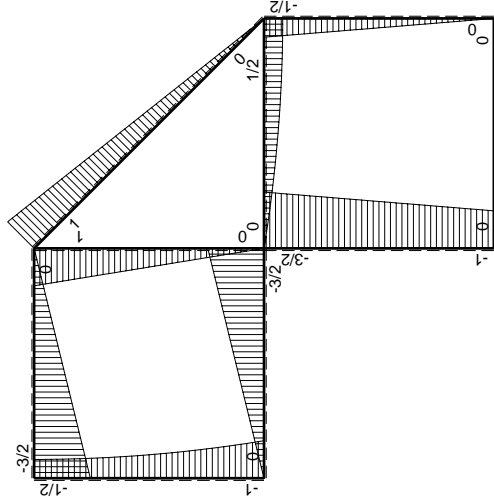
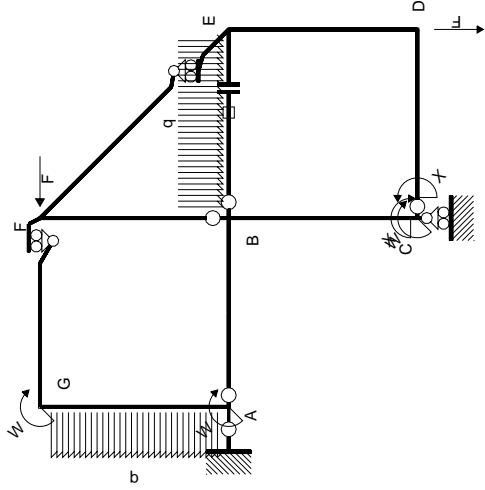

Schema di calcolo iperstatico

(\oplus) M_0 flessione da carichi assegnati

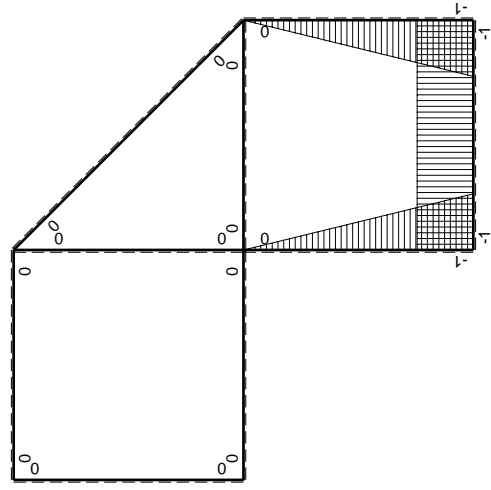

(\oplus) M_x flessione da iperstatica X=1

Quadro contribuiti PLV per iperstatica X=W_{cd}

→	$M_x(x)$	$M_0(x)$	$M_x M_0$	$M_x M_x$	$\int M_x M_0 / EJ dx$	$\int X M_x M_x / EJ dx$
AB b	0	-3/2Fx	0	0	0	0
BA b	0	3/2Fb-3/2Fx	0	0	0	0
BC b	-x/b	-3/2Fb+1/2Fx	3/2Fx-1/2Fx ² /b	x ² /b ²	7/12Fb ² /EJ	1/3Xb/EJ
CB b	1-x/b	Fb+1/2Fx	Fb-1/2Fx-1/2Fx ² /b	1-2x/b+x ² /b ²		
CD b	-1	0	0	1	0	Xb/EJ
DC b	1	0	0	1	0	
DE b	-1+x/b	-1/2Fx	1/2Fx-1/2Fx ² /b	1-2x/b+x ² /b ²	1/12Fb ² /EJ	1/3Xb/EJ
ED b	x/b	1/2Fb-1/2Fx	1/2Fx-1/2Fx ² /b	x ² /b ²		
EF √2b	0	√2/2Fx	0	0	0	0
FG b	0	-3/2Fx	0	0	0	0
GF b	0	3/2Fb-3/2Fx	0	0	0	0
GA b	0	-1/2Fb-1/2qx ²	0	0	0	0
AG b	0	Fb-Fx+1/2qx ²	0	0	0	0
FB b	0	Fb-Fx	0	0	0	0
BF b	0	-Fx	0	0	0	0
BE b	0	Fx-1/2qx ²	0	0	0	0
EB b	0	-1/2Fb+1/2qx ²	0	0	0	0
BE	elongazione asta $N_{1, BE} \epsilon_{BE} = L_{BE}$				Fb ² /EJ	
	totali				5/3Fb ² /EJ	5/3Xb/EJ
	iperstatica X=W _{cd}				-Fb	

Sviluppi di calcolo iperstatica

$$L_{BC}^{xx} = \int_0^b (x^2/b^2) 1/EJ dx = [1/3 x^3/b^2]_0^b 1/EJ$$

$$= (1/3 b) 1/EJ = 1/3 b/EJ$$

$$L_{CB}^{xx} = \int_0^b (1 - 2x/b + x^2/b^2) 1/EJ dx = [x - x^2/b + 1/3 x^3/b^2]_0^b 1/EJ$$

$$= (b - b + 1/3 b) 1/EJ = 1/3 b/EJ$$

$$L_{CD}^{xx} = \int_0^b (1) 1/EJ dx = [x]_0^b 1/EJ$$

$$= (b) 1/EJ = b/EJ$$

$$L_{DC}^{xx} = \int_0^b (1) 1/EJ dx = [x]_0^b 1/EJ$$

$$= (b) 1/EJ = b/EJ$$

$$L_{DE}^{xx} = \int_0^b (1 - 2x/b + x^2/b^2) 1/EJ dx = [x - x^2/b + 1/3 x^3/b^2]_0^b 1/EJ$$

$$= (b - b + 1/3 b) 1/EJ = 1/3 b/EJ$$

$$L_{ED}^{xx} = \int_0^b (x^2/b^2) 1/EJ dx = [1/3 x^3/b^2]_0^b 1/EJ$$

$$= (1/3 b) 1/EJ = 1/3 b/EJ$$

$$L_{BC}^{xo} = \int_0^b (3/2 x/b - 1/2 x^2/b^2) Fb 1/EJ dx = [3/4 x^2/b - 1/6 x^3/b^2]_0^b Fb 1/EJ$$

$$= (3/4 b - 1/6 b) Fb 1/EJ = 7/12 Fb^2/EJ$$

$$L_{CB}^{xo} = \int_0^b (1 - 1/2 x/b - 1/2 x^2/b^2) Fb 1/EJ dx = [x - 1/4 x^2/b - 1/6 x^3/b^2]_0^b Fb 1/EJ$$

$$= (b - 1/4 b - 1/6 b) Fb 1/EJ = 7/12 Fb^2/EJ$$

$$L_{DE}^{xo} = \int_0^b (1/2 x/b - 1/2 x^2/b^2) Fb 1/EJ dx = [1/4 x^2/b - 1/6 x^3/b^2]_0^b Fb 1/EJ$$

$$= (1/4 b - 1/6 b) Fb 1/EJ = 1/12 Fb^2/EJ$$

$$L_{ED}^{xo} = \int_0^b (1/2 x/b - 1/2 x^2/b^2) Fb 1/EJ dx = [1/4 x^2/b - 1/6 x^3/b^2]_0^b Fb 1/EJ$$

$$= (1/4 b - 1/6 b) Fb 1/EJ = 1/12 Fb^2/EJ$$

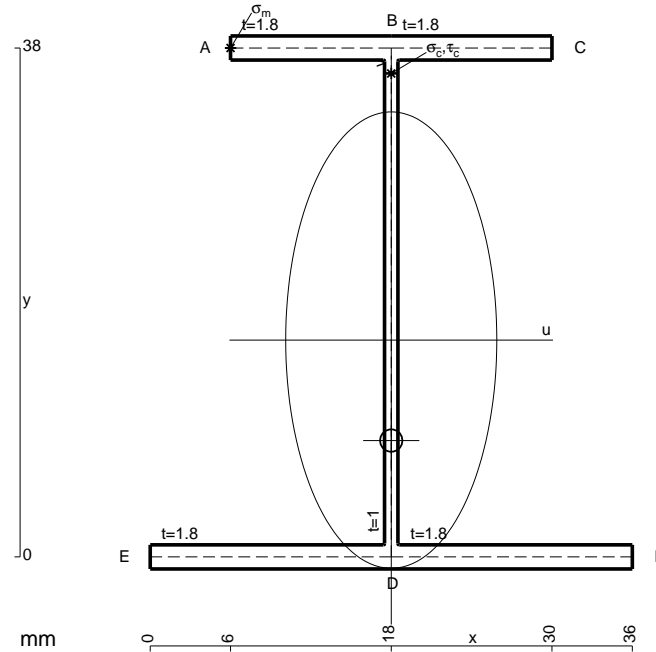

- A = 146. mm²
- J_u = 42407. mm⁴
- J_v = 9072. mm⁴
- J_i = 129.3 mm⁴
- y_o = -7.503 mm
- y_g = 16.19 mm
- T_y = -690. N
- M_x = -441600. Nmm
- x_m = 6. mm
- y_m = 38. mm
- u_m = -12. mm
- v_m = 21.81 mm
- σ_m = -M_y/J_u = 227.1 N/mm²
- x_c = 18. mm
- y_c = 38. mm
- v_c = 21.81 mm
- σ_c = -M_y/J_u = 227.1 N/mm²
- τ_c = T_S/t_{J_u} = 15.33 N/mm²
- τ_g = T_S/t_{J_u} = 15.33 N/mm²
- t_c = 460. mm
- σ_o = √σ²+3τ² = 228.7 N/mm²

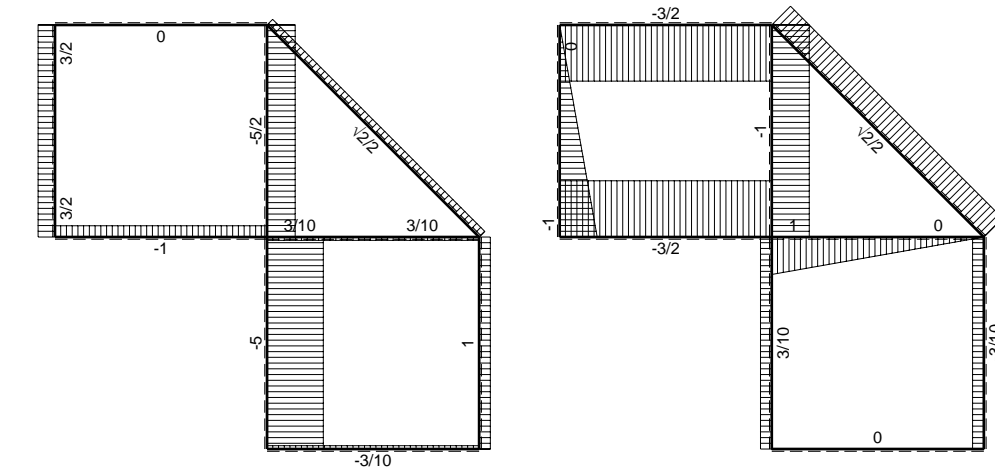
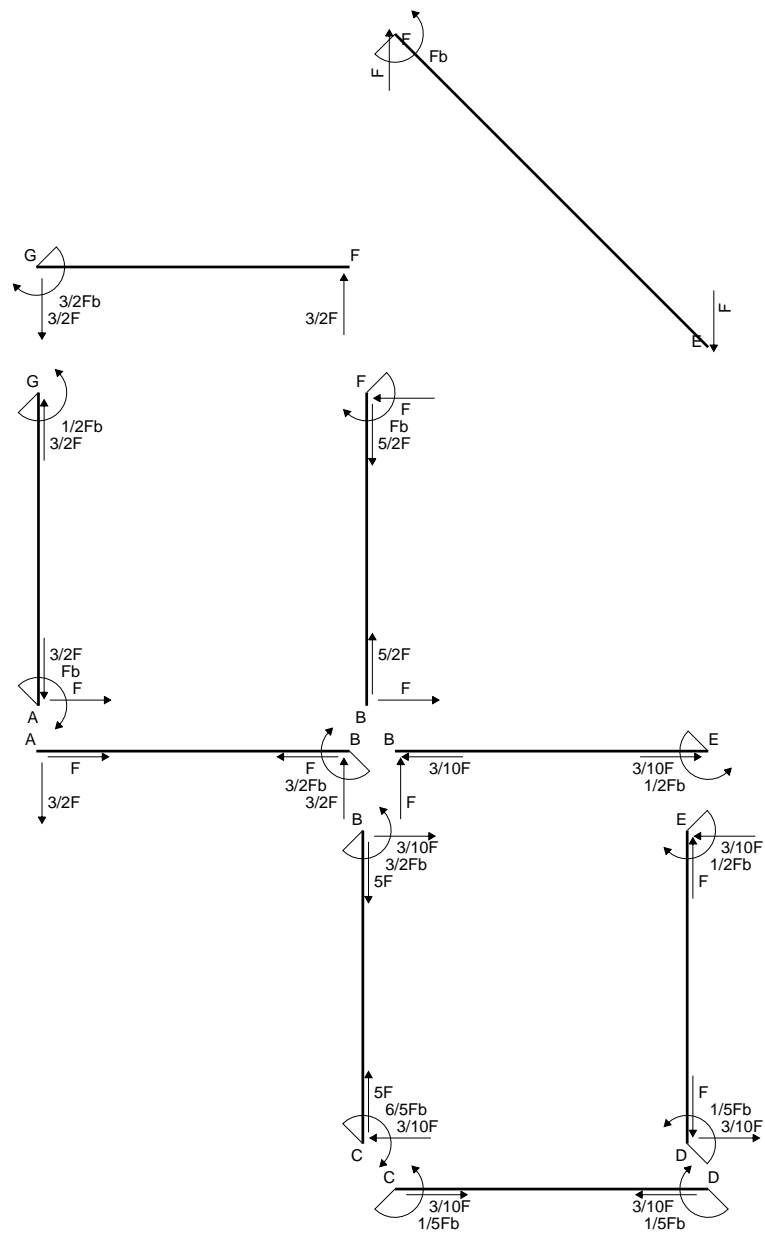

← ⊕ → F

↑ ⊕ ↓ F

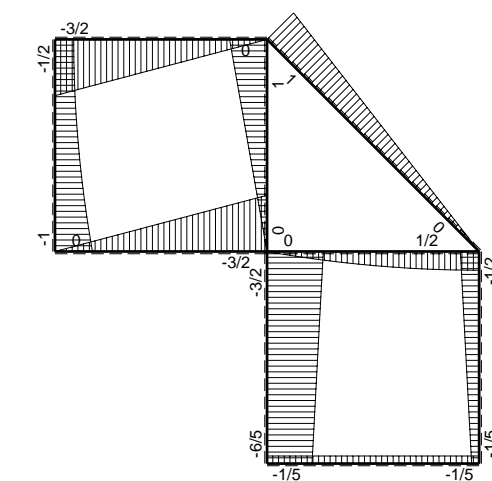

⊕ ⊖ F_b

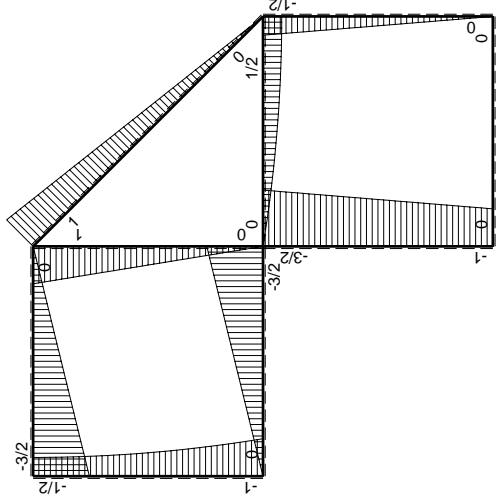
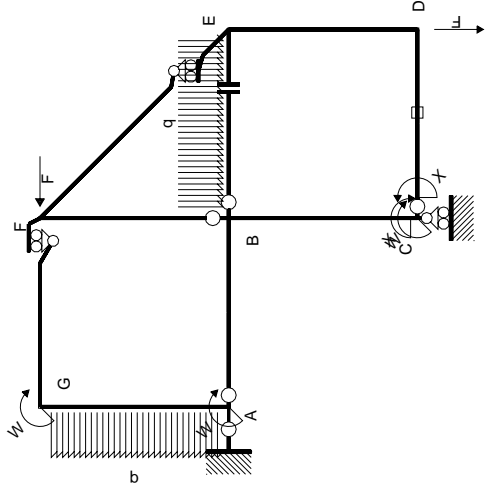

Schema di calcolo iperstatico

M_0 flessione da carichi assegnati

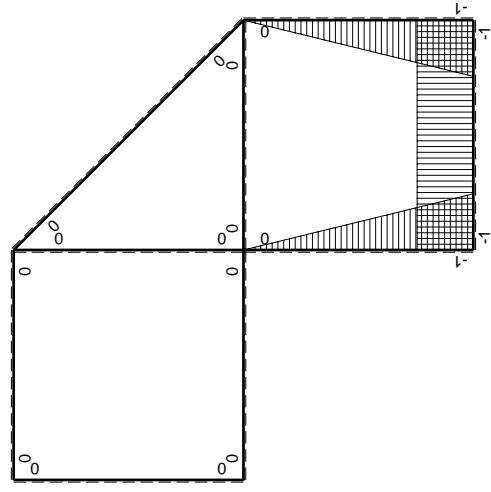

M_x flessione da iperstatica X=1

Quadro contributi PLV per iperstatica X=W_{cd}

→	$M_x(x)$	$M_0(x)$	$M_x M_0$	$M_x M_x$	$\int M_x M_0 / EJ dx$	$\int X M_x M_x / EJ dx$	
AB b	0	-3/2Fx	0	0	0	0	
BA b	0	3/2Fb-3/2Fx	0	0	0	0	
BC b	-x/b	-3/2Fb+1/2Fx	3/2Fx-1/2Fx ² /b	x ² /b ²	7/12Fb ² /EJ	1/3Xb/EJ	
CB b	1-x/b	Fb+1/2Fx	Fb-1/2Fx-1/2Fx ² /b	1-2x/b+x ² /b ²			
CD b	-1	0	0	1	0	Xb/EJ	
DC b	1	0	0	1	0		
DE b	-1+x/b	-1/2Fx	1/2Fx-1/2Fx ² /b	1-2x/b+x ² /b ²	1/12Fb ² /EJ	1/3Xb/EJ	
ED b	x/b	1/2Fb-1/2Fx	1/2Fx-1/2Fx ² /b	x ² /b ²			
EF √2b	0	√2/2Fx	0	0	0	0	
FG b	0	-3/2Fx	0	0	0	0	
GF b	0	3/2Fb-3/2Fx	0	0	0	0	
GA b	0	-1/2Fb-1/2qx ²	0	0	0	0	
AG b	0	Fb-Fx+1/2qx ²	0	0	0	0	
FB b	0	Fb-Fx	0	0	0	0	
BF b	0	-Fx	0	0	0	0	
BE b	0	Fx-1/2qx ²	0	0	0	0	
EB b	0	-1/2Fb+1/2qx ²	0	0	0	0	
CD	elongazione asta N _{1,cd} ε _{cd} l _{cd}						
	totali						
	iperstatica X=W _{cd}						
					-Fb ² /EJ		
					-1/3Fb ² /EJ	5/3Xb/EJ	
					1/5Fb		

Sviluppi di calcolo iperstatica

$$L_{BC}^{xx} = \int_0^b (x^2/b^2) 1/EJ dx = [1/3 x^3/b^2]_0^b 1/EJ$$

$$= (1/3 b) 1/EJ = 1/3 b/EJ$$

$$L_{CB}^{xx} = \int_0^b (1 - 2x/b + x^2/b^2) 1/EJ dx = [x - x^2/b + 1/3 x^3/b^2]_0^b 1/EJ$$

$$= (b - b + 1/3 b) 1/EJ = 1/3 b/EJ$$

$$L_{CD}^{xx} = \int_0^b (1) 1/EJ dx = [x]_0^b 1/EJ$$

$$= (b) 1/EJ = b/EJ$$

$$L_{DC}^{xx} = \int_0^b (1) 1/EJ dx = [x]_0^b 1/EJ$$

$$= (b) 1/EJ = b/EJ$$

$$L_{DE}^{xx} = \int_0^b (1 - 2x/b + x^2/b^2) 1/EJ dx = [x - x^2/b + 1/3 x^3/b^2]_0^b 1/EJ$$

$$= (b - b + 1/3 b) 1/EJ = 1/3 b/EJ$$

$$L_{ED}^{xx} = \int_0^b (x^2/b^2) 1/EJ dx = [1/3 x^3/b^2]_0^b 1/EJ$$

$$= (1/3 b) 1/EJ = 1/3 b/EJ$$

$$L_{BC}^{xo} = \int_0^b (3/2 x/b - 1/2 x^2/b^2) Fb 1/EJ dx = [3/4 x^2/b - 1/6 x^3/b^2]_0^b Fb 1/EJ$$

$$= (3/4 b - 1/6 b) Fb 1/EJ = 7/12 Fb^2/EJ$$

$$L_{CB}^{xo} = \int_0^b (1 - 1/2 x/b - 1/2 x^2/b^2) Fb 1/EJ dx = [x - 1/4 x^2/b - 1/6 x^3/b^2]_0^b Fb 1/EJ$$

$$= (b - 1/4 b - 1/6 b) Fb 1/EJ = 7/12 Fb^2/EJ$$

$$L_{DE}^{xo} = \int_0^b (1/2 x/b - 1/2 x^2/b^2) Fb 1/EJ dx = [1/4 x^2/b - 1/6 x^3/b^2]_0^b Fb 1/EJ$$

$$= (1/4 b - 1/6 b) Fb 1/EJ = 1/12 Fb^2/EJ$$

$$L_{ED}^{xo} = \int_0^b (1/2 x/b - 1/2 x^2/b^2) Fb 1/EJ dx = [1/4 x^2/b - 1/6 x^3/b^2]_0^b Fb 1/EJ$$

$$= (1/4 b - 1/6 b) Fb 1/EJ = 1/12 Fb^2/EJ$$

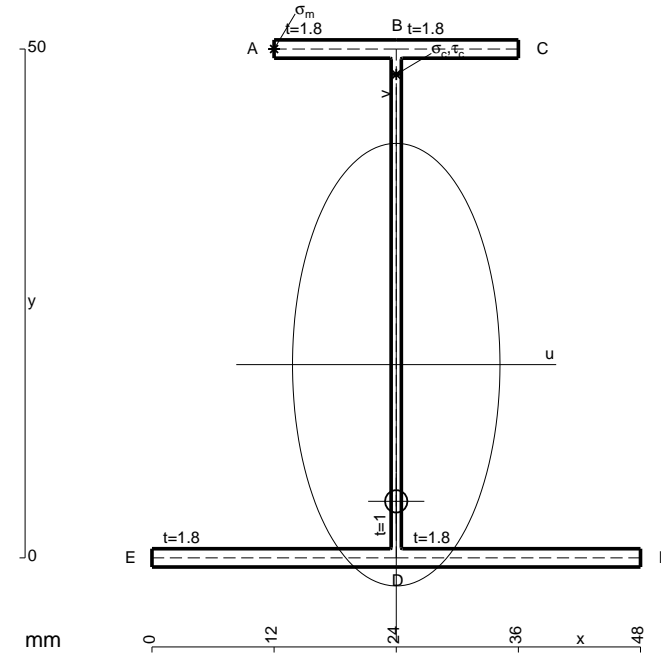

- A = 179.6 mm²
- J_u = 84922. mm⁴
- J_v = 18662. mm⁴
- J_i = 156.6 mm⁴
- y_o = -13.43 mm
- y_g = 18.99 mm
- T_y = -735. N
- M_x = -654150. Nmm
- x_m = 12. mm
- y_m = 50. mm
- u_m = -12. mm
- v_m = 31.01 mm
- σ_m = -Mv/J_u = 238.9 N/mm²
- x_c = 24. mm
- y_c = 50. mm
- v_c = 31.01 mm
- σ_c = -Mv/J_u = 238.9 N/mm²
- τ_c = TS'/tJ_u = 11.6 N/mm²
- τ_g = TS'/tJ_u = 11.6 N/mm²
- t_c = 490. mm
- σ_o = √(σ²+3τ²) = 239.7 N/mm²

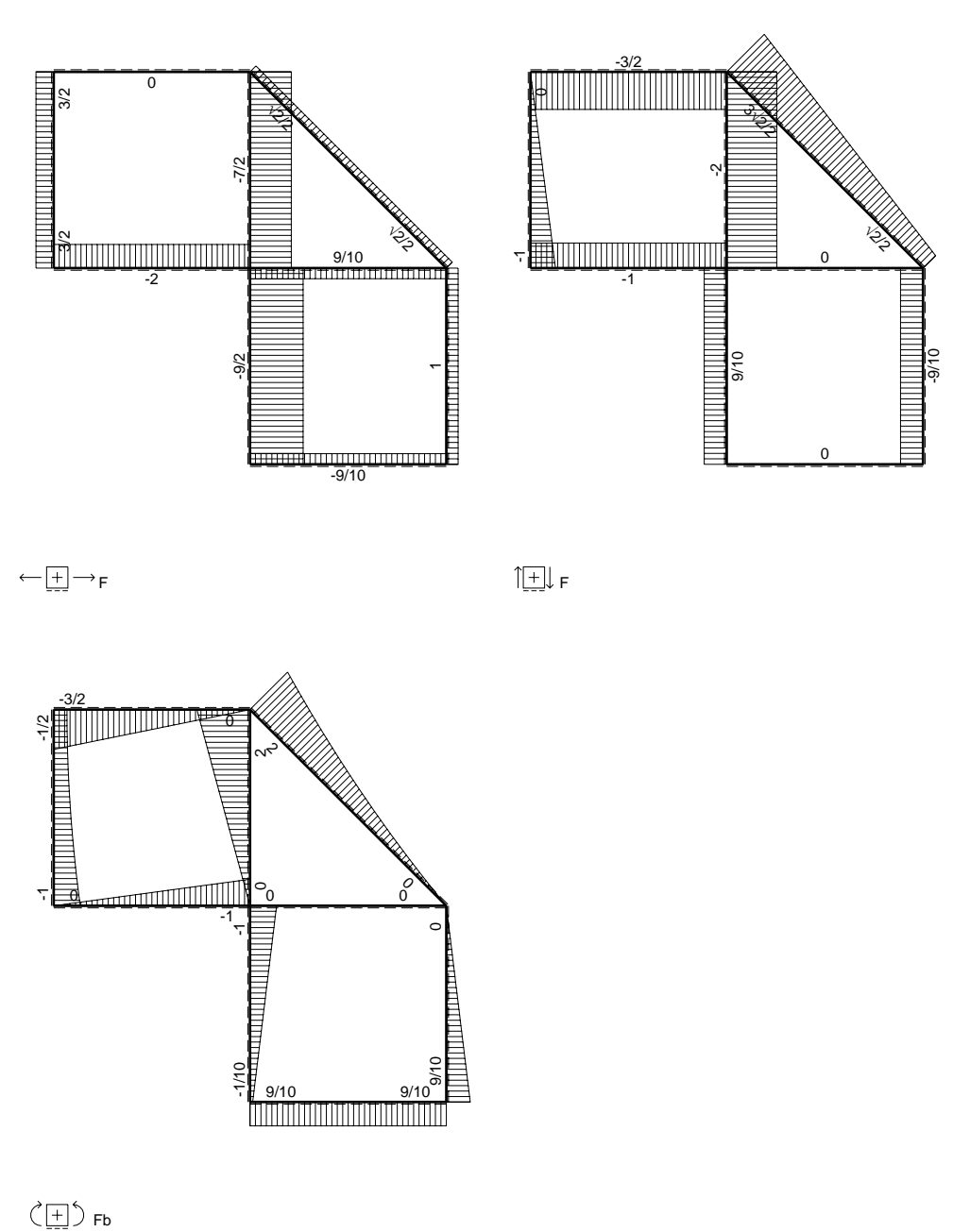
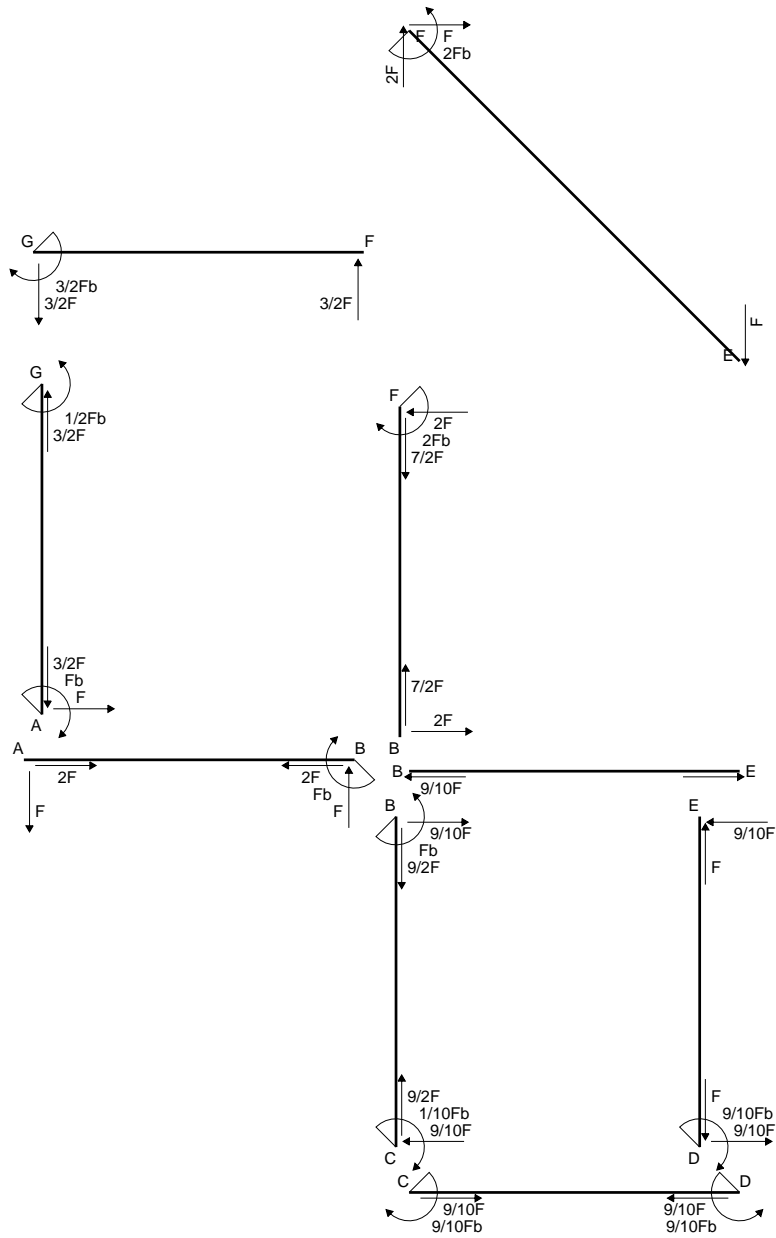

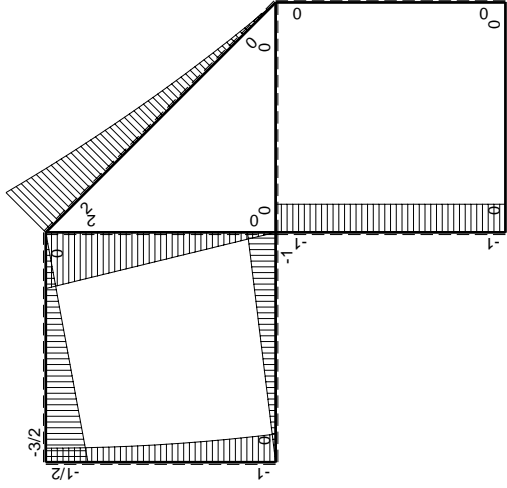
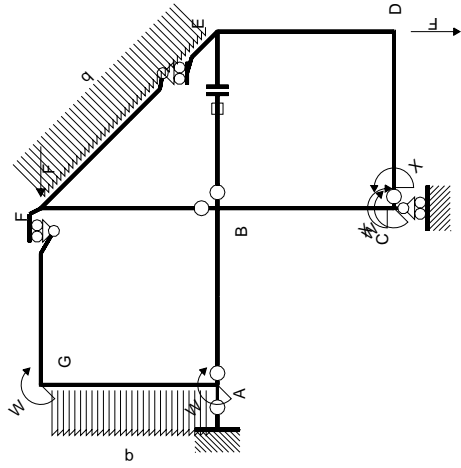

Schema di calcolo iperstatico

M_0 flessione da carichi assegnati

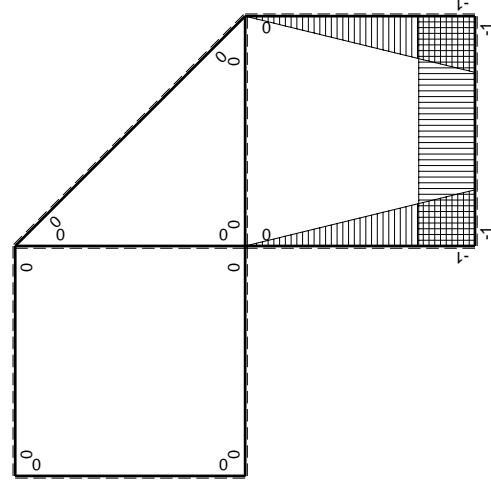

M_x flessione da iperstatica $X=1$

Quadro contribuiti PLV per iperstatica $X=W_{cd}$

\rightarrow	$M_x(x)$	$M_0(x)$	$M_x M_0$	$M_x M_x$	$\int M_x M_0 / EJ dx$	$\int M_x M_x / EJ dx$
AB b	0	-Fx	0	0	0	0
BA b	0	Fb-Fx	0	0	0	0
BC b	-x/b	-Fb	Fx	x^2/b^2	$1/2 Fb^2/EJ$	$1/3 Xb/EJ$
CB b	$1-x/b$	Fb	Fb-Fx	$1-2x/b+x^2/b^2$		
CD b	-1	0	0	1	0	Xb/EJ
DC b	1	0	0	1	0	
DE b	$-1+x/b$	0	0	$1-2x/b+x^2/b^2$	0	$1/3 Xb/EJ$
ED b	x/b	0	0	x^2/b^2	0	0
EF $\sqrt{2}b$	0	$\sqrt{2}/2 Fx + 1/2 qx^2$	0	0	0	0
FG b	0	-3/2 Fx	0	0	0	0
GF b	0	$3/2 Fb - 3/2 Fx$	0	0	0	0
GA b	0	$-1/2 Fb - 1/2 qx^2$	0	0	0	0
AG b	0	$Fb - Fx + 1/2 qx^2$	0	0	0	0
FB b	0	$2Fb - 2Fx$	0	0	0	0
BF b	0	-2Fx	0	0	0	0
BE b	0	0	0	0	0	0
EB b	0	0	0	0	0	0
BE	elongazione asta $N_{1, BE} \epsilon_{BE} = L_{BE}$				Fb^2/EJ	
	totali				$3/2 Fb^2/EJ$	$5/3 Xb/EJ$
	iperstatica $X=W_{cd}$					$-9/10 Fb$

Sviluppi di calcolo iperstatica

$$L_{BC}^{xx} = \int_0^b (x^2/b^2) 1/EJ dx = [1/3 x^3/b^2]_0^b 1/EJ$$

$$= (1/3 b) 1/EJ = 1/3 b/EJ$$

$$L_{CB}^{xx} = \int_0^b (1 - 2x/b + x^2/b^2) 1/EJ dx = [x - x^2/b + 1/3 x^3/b^2]_0^b 1/EJ$$

$$= (b - b + 1/3 b) 1/EJ = 1/3 b/EJ$$

$$L_{CD}^{xx} = \int_0^b (1) 1/EJ dx = [x]_0^b 1/EJ$$

$$= (b) 1/EJ = b/EJ$$

$$L_{DC}^{xx} = \int_0^b (1) 1/EJ dx = [x]_0^b 1/EJ$$

$$= (b) 1/EJ = b/EJ$$

$$L_{DE}^{xx} = \int_0^b (1 - 2x/b + x^2/b^2) 1/EJ dx = [x - x^2/b + 1/3 x^3/b^2]_0^b 1/EJ$$

$$= (b - b + 1/3 b) 1/EJ = 1/3 b/EJ$$

$$L_{ED}^{xx} = \int_0^b (x^2/b^2) 1/EJ dx = [1/3 x^3/b^2]_0^b 1/EJ$$

$$= (1/3 b) 1/EJ = 1/3 b/EJ$$

$$L_{BC}^{xo} = \int_0^b (x/b) Fb 1/EJ dx = [1/2 x^2/b]_0^b Fb 1/EJ$$

$$= (1/2 b) Fb 1/EJ = 1/2 Fb^2/EJ$$

$$L_{CB}^{xo} = \int_0^b (1 - x/b) Fb 1/EJ dx = [x - 1/2 x^2/b]_0^b Fb 1/EJ$$

$$= (b - 1/2 b) Fb 1/EJ = 1/2 Fb^2/EJ$$

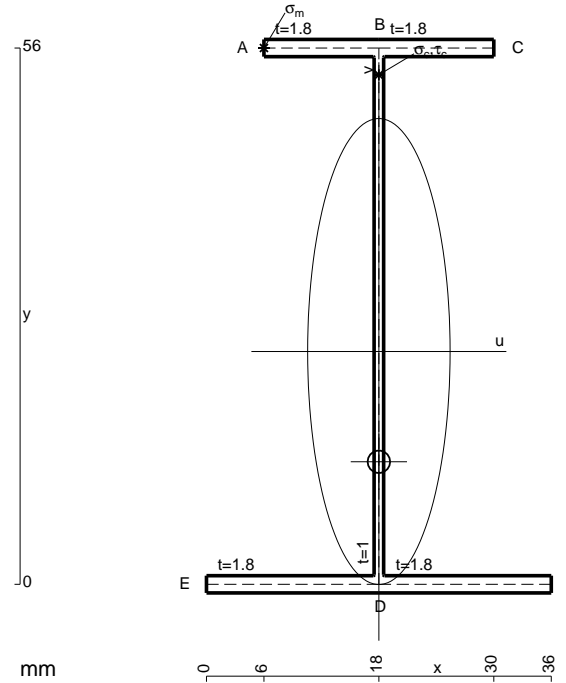

- A = 164. mm²
- J_u = 97076. mm⁴
- J_v = 9072. mm⁴
- J_i = 135.3 mm⁴
- y_o = -11.51 mm
- y_g = 24.31 mm
- N = -1890. N
- T_y = -1080. N
- M_x = 572400. Nmm
- x_m = 6. mm
- y_m = 56. mm
- u_m = -12. mm
- v_m = 31.69 mm
- σ_m = N/A - Mv/J_u = -198.4 N/mm²
- x_c = 18. mm
- y_c = 56. mm
- v_c = 31.69 mm
- σ_c = N/A - Mv/J_u = -198.4 N/mm²
- τ_c = TS/tJ_u = 15.23 N/mm²
- τ_g = TS/tJ_u = 15.23 N/mm²
- t_c = 540. mm
- σ_o = √σ² + 3τ² = 200.1 N/mm²

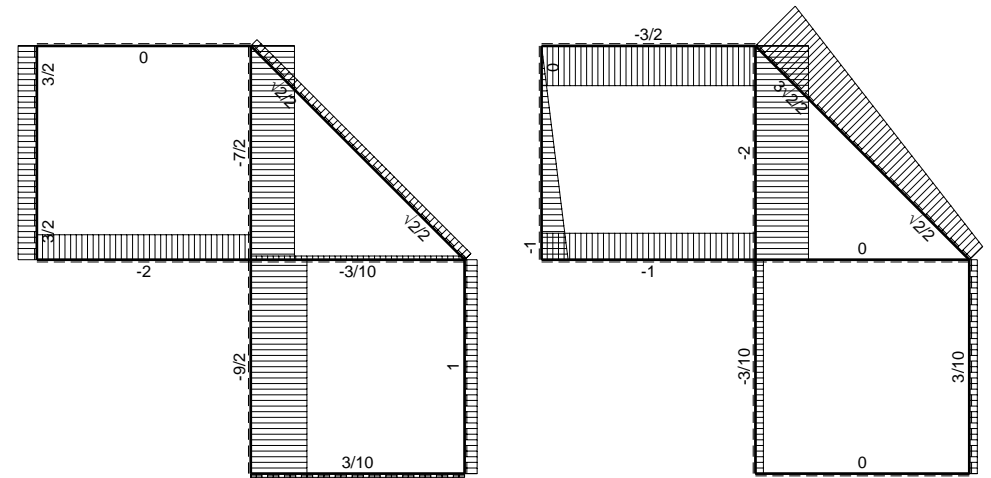
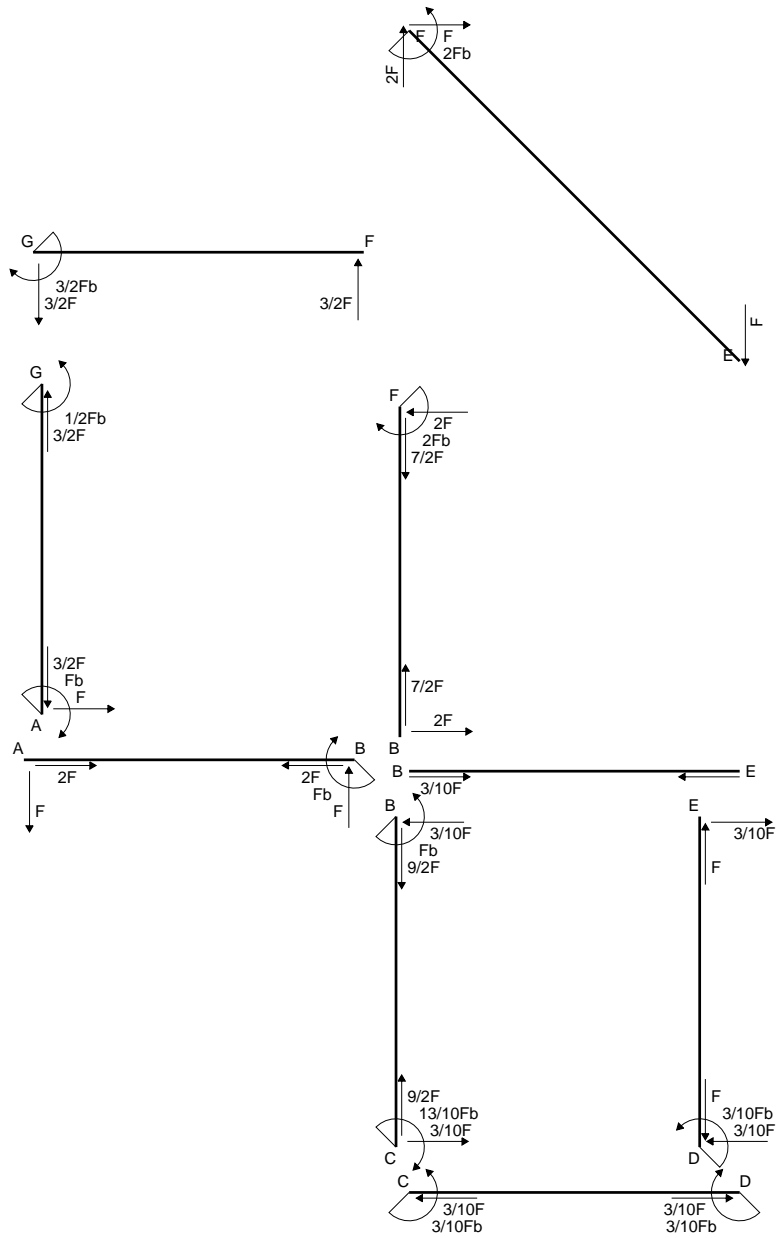

← ⊕ → F

↑ ⊕ ↓ F

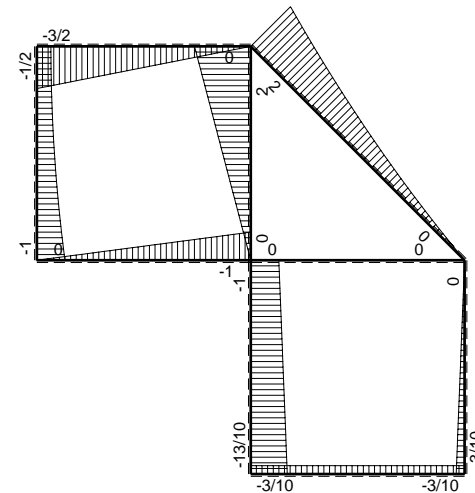

⊕ ⊖ F_b

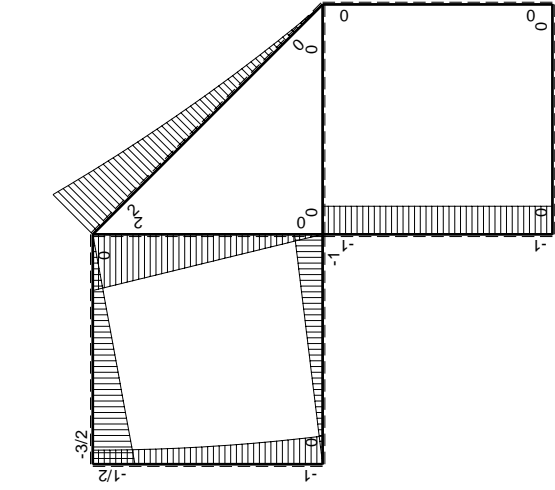
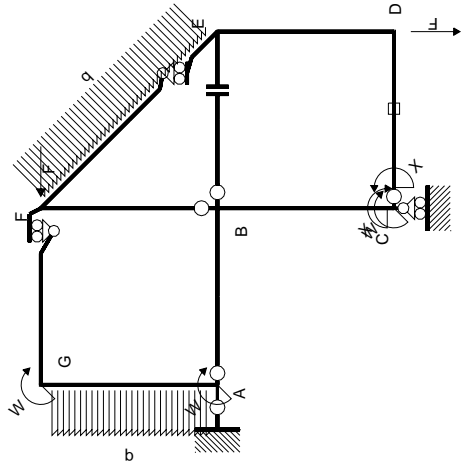

Schema di calcolo iperstatico

M_0 flessione da carichi assegnati

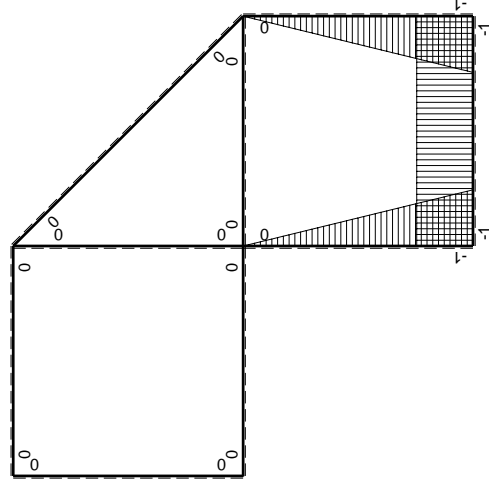

M_x flessione da iperstatica $X=1$

Quadro contributi PLV per iperstatica $X=W_{cd}$

\rightarrow	$M_x(x)$	$M_0(x)$	$M_x M_0$	$M_x M_x$	$\int M_x M_0 / EJ dx$	$\int M_x M_x / EJ dx$
AB b	0	-Fx	0	0	0	0
BA b	0	Fb-Fx	0	0	0	0
BC b	-x/b	-Fb	Fx	x^2/b^2		
CB b	1-x/b	Fb	Fb-Fx	$1-2x/b+x^2/b^2$	$1/2Fb^2/EJ$	$1/3Xb/EJ$
CD b	-1	0	0	1	0	Xb/EJ
DC b	1	0	0	1	0	$1/3Xb/EJ$
DE b	-1+x/b	0	0	$1-2x/b+x^2/b^2$	0	0
ED b	x/b	0	0	x^2/b^2	0	0
EF $\sqrt{2}b$	0	$\sqrt{2}/2Fx+1/2qx^2$	0	0	0	0
FG b	0	-3/2Fx	0	0	0	0
GF b	0	3/2Fb-3/2Fx	0	0	0	0
GA b	0	-1/2Fb-1/2qx^2	0	0	0	0
AG b	0	Fb-Fx+1/2qx^2	0	0	0	0
FB b	0	2Fb-2Fx	0	0	0	0
BF b	0	-2Fx	0	0	0	0
BE b	0	0	0	0	0	0
EB b	0	0	0	0	0	0
CD	elongazione asta $N_{1,cd} \epsilon_{cd} L_{cd}$				$-Fb^2/EJ$	
	totali				$-1/2Fb^2/EJ$	$5/3Xb/EJ$
	iperstatica $X=W_{cd}$				$3/10Fb$	

Sviluppi di calcolo iperstatica

$$L_{BC}^{xx} = \int_0^b (x^2/b^2) 1/EJ dx = [1/3 x^3/b^2]_0^b 1/EJ$$

$$= (1/3 b) 1/EJ = 1/3 b/EJ$$

$$L_{CB}^{xx} = \int_0^b (1 - 2x/b + x^2/b^2) 1/EJ dx = [x - x^2/b + 1/3 x^3/b^2]_0^b 1/EJ$$

$$= (b - b + 1/3 b) 1/EJ = 1/3 b/EJ$$

$$L_{CD}^{xx} = \int_0^b (1) 1/EJ dx = [x]_0^b 1/EJ$$

$$= (b) 1/EJ = b/EJ$$

$$L_{DC}^{xx} = \int_0^b (1) 1/EJ dx = [x]_0^b 1/EJ$$

$$= (b) 1/EJ = b/EJ$$

$$L_{DE}^{xx} = \int_0^b (1 - 2x/b + x^2/b^2) 1/EJ dx = [x - x^2/b + 1/3 x^3/b^2]_0^b 1/EJ$$

$$= (b - b + 1/3 b) 1/EJ = 1/3 b/EJ$$

$$L_{ED}^{xx} = \int_0^b (x^2/b^2) 1/EJ dx = [1/3 x^3/b^2]_0^b 1/EJ$$

$$= (1/3 b) 1/EJ = 1/3 b/EJ$$

$$L_{BC}^{xo} = \int_0^b (x/b) Fb 1/EJ dx = [1/2 x^2/b]_0^b Fb 1/EJ$$

$$= (1/2 b) Fb 1/EJ = 1/2 Fb^2/EJ$$

$$L_{CB}^{xo} = \int_0^b (1 - x/b) Fb 1/EJ dx = [x - 1/2 x^2/b]_0^b Fb 1/EJ$$

$$= (b - 1/2 b) Fb 1/EJ = 1/2 Fb^2/EJ$$

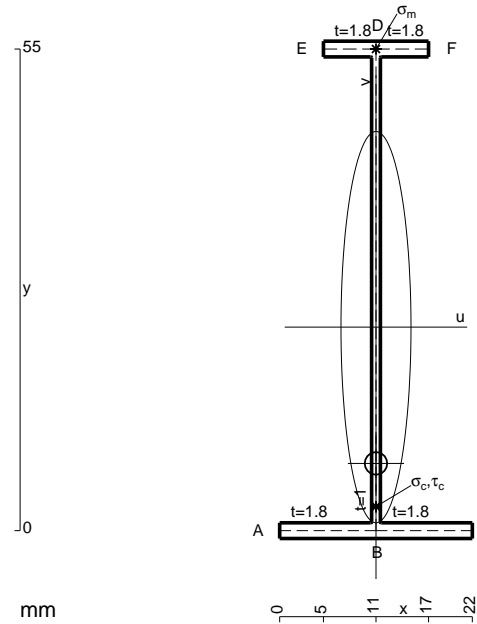

$A = 116.2 \text{ mm}^2$
 $J_u = 58038. \text{ mm}^4$
 $J_v = 1856. \text{ mm}^4$
 $J_t = 84.43 \text{ mm}^4$
 $y_o = -15.56 \text{ mm}$
 $y_g = 23.24 \text{ mm}$
 $N = 233.3 \text{ N}$
 $T_y = 700. \text{ N}$
 $M_x = 376200. \text{ Nmm}$
 $x_m = 11. \text{ mm}$
 $y_m = 55. \text{ mm}$
 $v_m = 31.76 \text{ mm}$
 $\sigma_m = N/A - Mv/J_u = -203.9 \text{ N/mm}^2$
 $x_c = 11. \text{ mm}$
 $v_c = -23.24 \text{ mm}$
 $\sigma_c = N/A - Mv/J_u = 152.6 \text{ N/mm}^2$
 $\tau_c = TS'/tJ_u = 11.1 \text{ N/mm}^2$
 $\tau_g = TS'/tJ_u = 11.1 \text{ N/mm}^2$
 $t_c = 330. \text{ mm}$
 $\sigma_o = \sqrt{\sigma^2 + 3\tau^2} = 153.9 \text{ N/mm}^2$

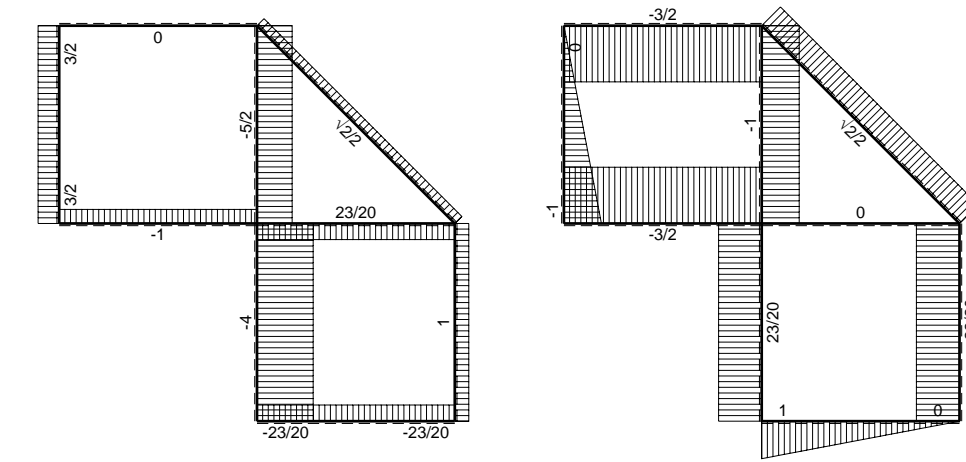
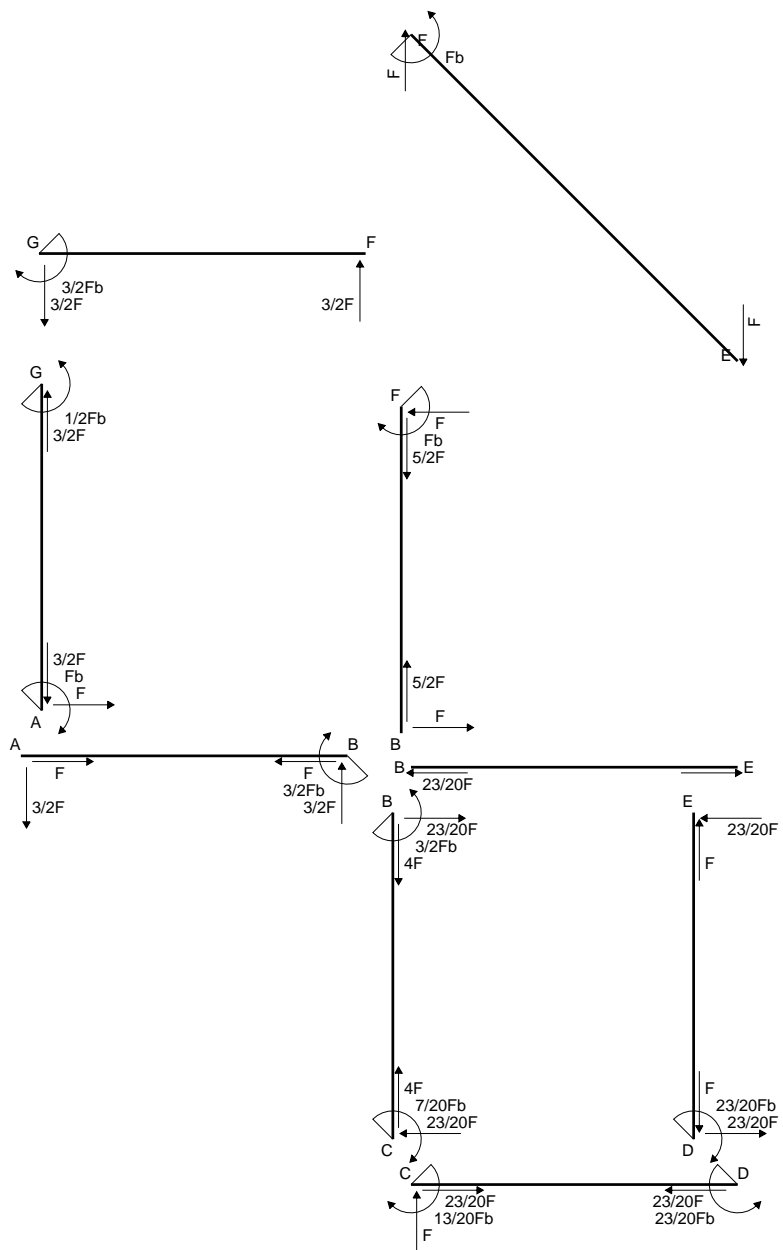

← ⊕ → F

↑ ⊕ ↓ F

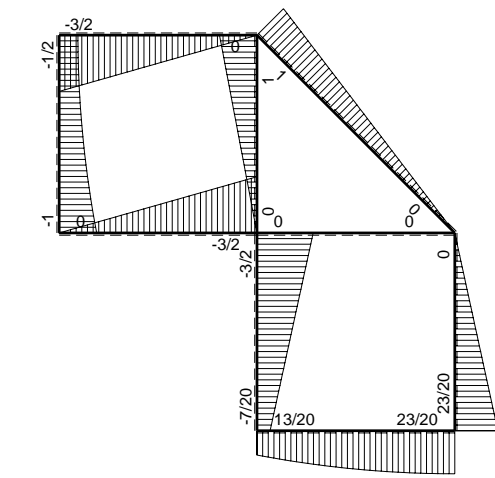

⊕ ⊖ F_b

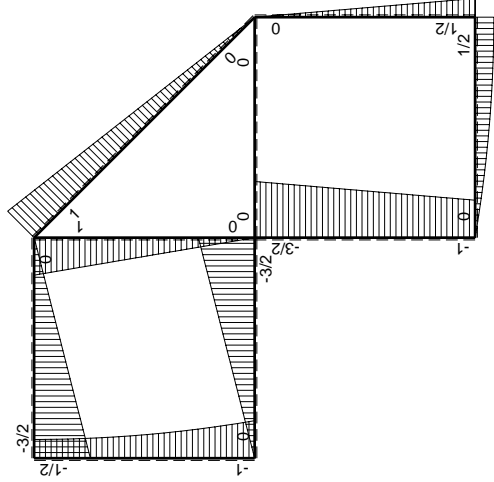
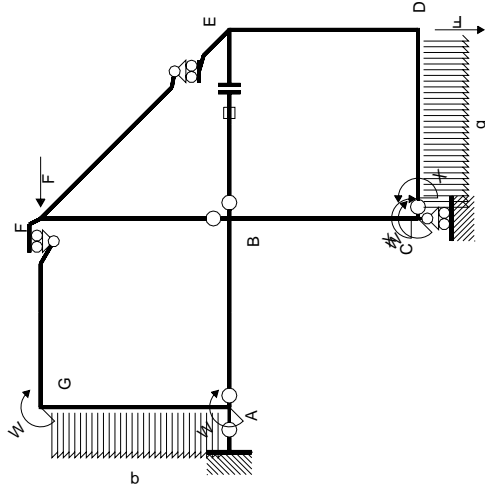

(\oplus) M_0 flessione da carichi assegnati

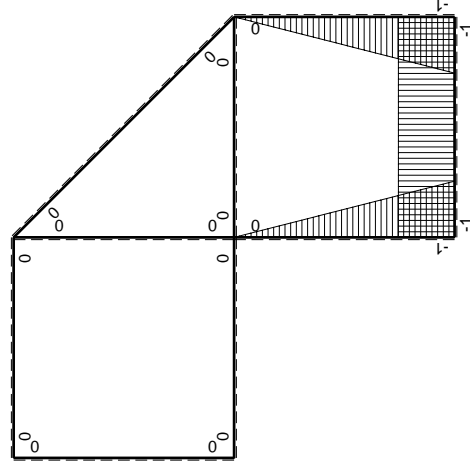

(\oplus) M_x flessione da iperstatica X=1

Quadro contribuiti PLV per iperstatica X=W_{CD}

→	$M_x(x)$	$M_0(x)$	$M_x M_0$	$M_x M_x$	$\int M_x M_0 / EJ dx$	$\int X M_x M_x / EJ dx$
AB b	0	-3/2Fx	0	0	0	0
BA b	0	3/2Fb-3/2Fx	0	0	0	0
BC b	-x/b	-3/2Fb+1/2Fx	3/2Fx-1/2Fx ² /b	x ² /b ²	7/12Fb ² /EJ	1/3Xb/EJ
CB b	1-x/b	Fb+1/2Fx	Fb-1/2Fx-1/2Fx ² /b	1-2x/b+x ² /b ²		
CD b	-1	Fx-1/2qx ²	-Fx+1/2Fx ² /b	1	-1/3Fb ² /EJ	Xb/EJ
DC b	1	-1/2Fb+1/2qx ²	-1/2Fb+1/2Fx ² /b	1		
DE b	-1+x/b	1/2Fb-1/2Fx	-1/2Fb+Fx-1/2Fx ² /b	1-2x/b+x ² /b ²	-1/6Fb ² /EJ	1/3Xb/EJ
ED b	x/b	-1/2Fx	-1/2Fx ² /b	x ² /b ²		
EF √2b	0	√2/2Fx	0	0	0	0
FG b	0	-3/2Fx	0	0	0	0
GF b	0	3/2Fb-3/2Fx	0	0	0	0
GA b	0	-1/2Fb-1/2qx ²	0	0	0	0
AG b	0	Fb-Fx+1/2qx ²	0	0	0	0
FB b	0	Fb-Fx	0	0	0	0
BF b	0	-Fx	0	0	0	0
BE b	0	0	0	0	0	0
EB b	0	0	0	0	0	0
BE	elongazione asta $N_{1, BE}^{\epsilon_{BE} - BE}$				Fb ² /EJ	
	totali				13/12Fb ² /EJ	5/3Xb/EJ
	iperstatica X=W _{CD}				-13/20Fb	

Sviluppi di calcolo iperstatica

$$L_{BC}^{xx} = \int_0^b (x^2/b^2) 1/EJ dx = [1/3 x^3/b^2]_0^b 1/EJ$$

$$= (1/3 b) 1/EJ = 1/3 b/EJ$$

$$L_{CB}^{xx} = \int_0^b (1 - 2x/b + x^2/b^2) 1/EJ dx = [x - x^2/b + 1/3 x^3/b^2]_0^b 1/EJ$$

$$= (b - b + 1/3 b) 1/EJ = 1/3 b/EJ$$

$$L_{CD}^{xx} = \int_0^b (1) 1/EJ dx = [x]_0^b 1/EJ$$

$$= (b) 1/EJ = b/EJ$$

$$L_{DC}^{xx} = \int_0^b (1) 1/EJ dx = [x]_0^b 1/EJ$$

$$= (b) 1/EJ = b/EJ$$

$$L_{DE}^{xx} = \int_0^b (1 - 2x/b + x^2/b^2) 1/EJ dx = [x - x^2/b + 1/3 x^3/b^2]_0^b 1/EJ$$

$$= (b - b + 1/3 b) 1/EJ = 1/3 b/EJ$$

$$L_{ED}^{xx} = \int_0^b (x^2/b^2) 1/EJ dx = [1/3 x^3/b^2]_0^b 1/EJ$$

$$= (1/3 b) 1/EJ = 1/3 b/EJ$$

$$L_{BC}^{x_0} = \int_0^b (3/2 x/b - 1/2 x^2/b^2) Fb 1/EJ dx = [3/4 x^2/b - 1/6 x^3/b^2]_0^b Fb 1/EJ$$

$$= (3/4 b - 1/6 b) Fb 1/EJ = 7/12 Fb^2/EJ$$

$$L_{CB}^{x_0} = \int_0^b (1 - 1/2 x/b - 1/2 x^2/b^2) Fb 1/EJ dx = [x - 1/4 x^2/b - 1/6 x^3/b^2]_0^b Fb 1/EJ$$

$$= (b - 1/4 b - 1/6 b) Fb 1/EJ = 7/12 Fb^2/EJ$$

$$L_{CD}^{x_0} = \int_0^b (-x/b + 1/2 x^2/b^2) Fb 1/EJ dx = [-1/2 x^2/b + 1/6 x^3/b^2]_0^b Fb 1/EJ$$

$$= (-1/2 b + 1/6 b) Fb 1/EJ = -1/3 Fb^2/EJ$$

$$L_{DC}^{x_0} = \int_0^b (-1/2 + 1/2 x^2/b^2) Fb 1/EJ dx = [-1/2 x + 1/6 x^3/b^2]_0^b Fb 1/EJ$$

$$= (-1/2 b + 1/6 b) Fb 1/EJ = -1/3 Fb^2/EJ$$

$$L_{DE}^{x_0} = \int_0^b (-1/2 + x/b - 1/2 x^2/b^2) Fb 1/EJ dx = [-1/2 x + 1/2 x^2/b - 1/6 x^3/b^2]_0^b Fb 1/EJ$$

$$= (-1/2 b + 1/2 b - 1/6 b) Fb 1/EJ = -1/6 Fb^2/EJ$$

$$L_{ED}^{x_0} = \int_0^b (-1/2 x^2/b^2) Fb 1/EJ dx = [-1/6 x^3/b^2]_0^b Fb 1/EJ$$

$$= (-1/6 b) Fb 1/EJ = -1/6 Fb^2/EJ$$

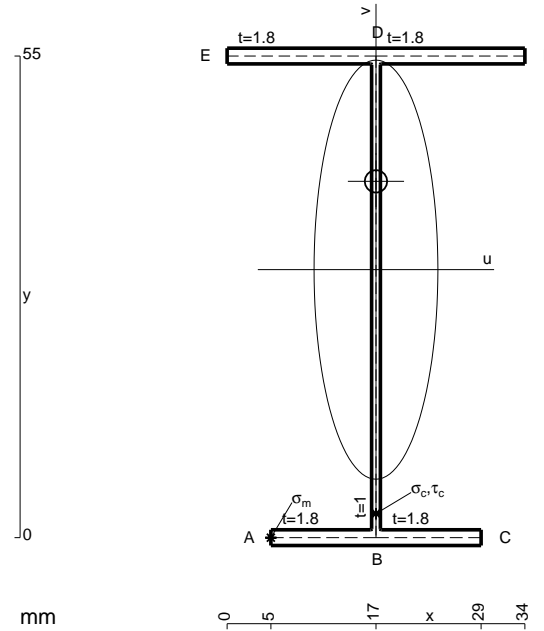

- A = 159.4 mm²
- J_u = 91280. mm⁴
- J_v = 7969. mm⁴
- J_i = 131.1 mm⁴
- y_o = 10.08 mm
- y_g = 30.61 mm
- N = -690. N
- T_y = -1035. N
- M_x = -641700. Nmm
- x_m = 5. mm
- u_m = -12. mm
- v_m = -30.61 mm
- σ_m = N/A-Mv/J_u = -219.5 N/mm²
- x_c = 17. mm
- v_c = -30.61 mm
- σ_c = N/A-Mv/J_u = -219.5 N/mm²
- τ_c = TS_v/tJ_u = 14.99 N/mm²
- τ_g = TS_v/tJ_u = 14.99 N/mm²
- t_c = 690. mm
- σ_o = √σ²+3τ² = 221. N/mm²

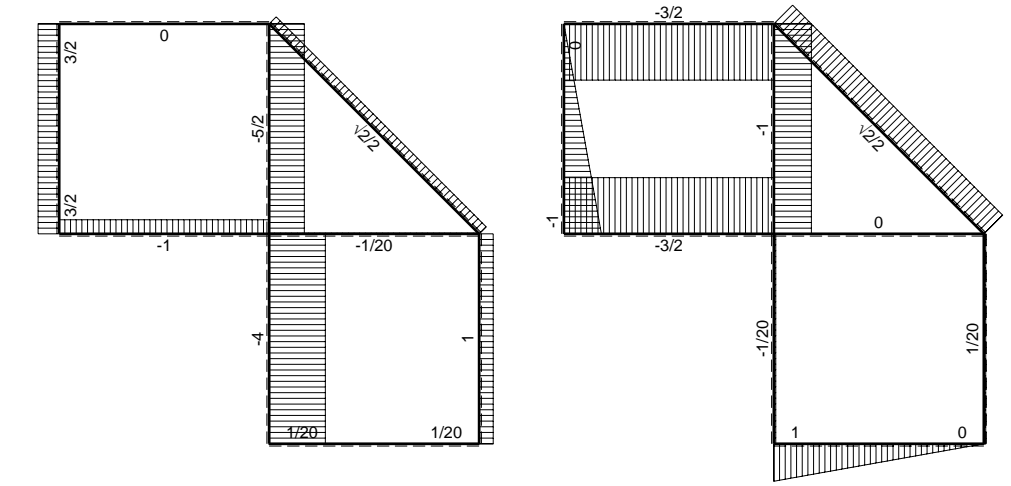
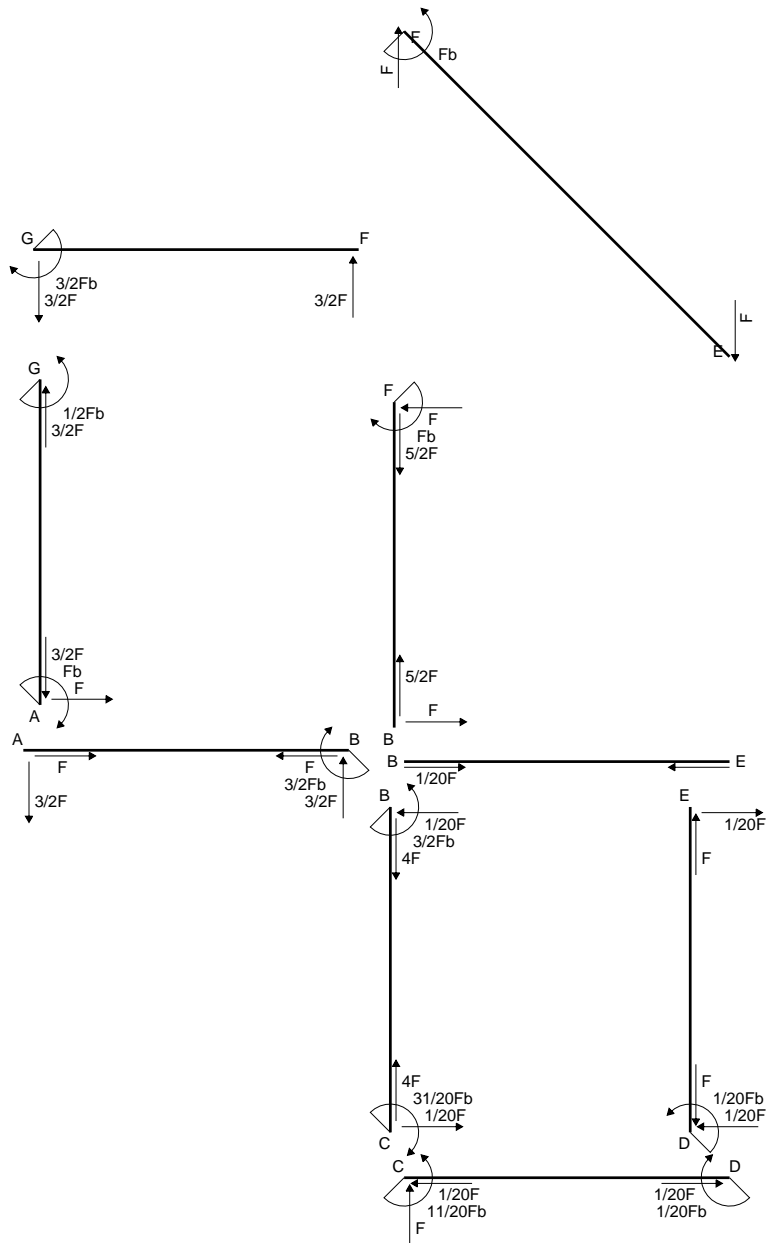

← ⊕ → F

↑ ⊕ ↓ F_b

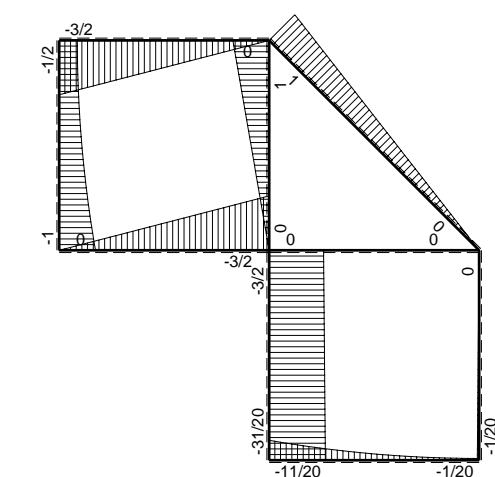

⊕ ⊖ F_b

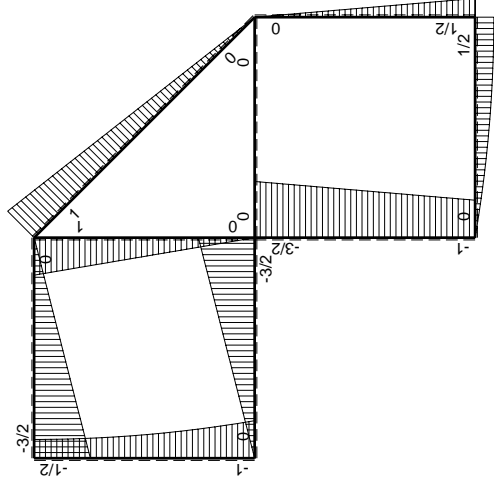
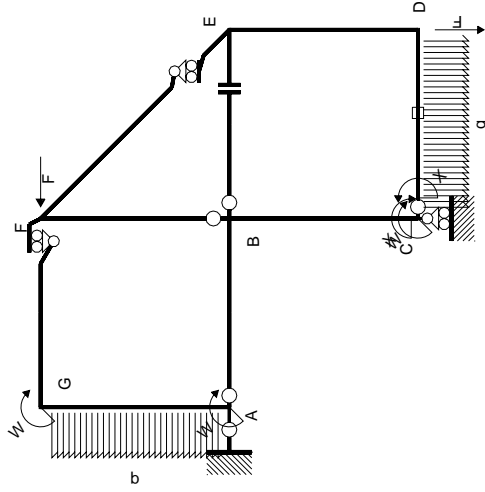

(\oplus) M_0 flessione da carichi assegnati

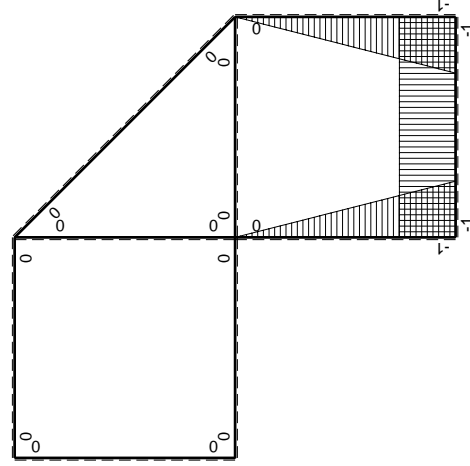

(\oplus) M_x flessione da iperstatica $X=1$

Quadro contribuiti PLV per iperstatica $X=W_{cd}$

\rightarrow	$M_x(x)$	$M_0(x)$	$M_x M_0$	$M_x M_x$	$\int M_x M_0 / EJ dx$	$\int X M_x M_x / EJ dx$
AB b	0	-3/2Fx	0	0	0	0
BA b	0	3/2Fb-3/2Fx	0	0	0	0
BC b	-x/b	-3/2Fb+1/2Fx	3/2Fx-1/2Fx ² /b	x ² /b ²	7/12Fb ² /EJ	1/3Xb/EJ
CB b	1-x/b	Fb+1/2Fx	Fb-1/2Fx-1/2Fx ² /b	1-2x/b+x ² /b ²		
CD b	-1	Fx-1/2qx ²	-Fx+1/2Fx ² /b	1	-1/3Fb ² /EJ	Xb/EJ
DC b	1	-1/2Fb+1/2qx ²	-1/2Fb+1/2Fx ² /b	1		
DE b	-1+x/b	1/2Fb-1/2Fx	-1/2Fb+Fx-1/2Fx ² /b	1-2x/b+x ² /b ²	-1/6Fb ² /EJ	1/3Xb/EJ
ED b	x/b	-1/2Fx	-1/2Fx ² /b	x ² /b ²		
EF $\sqrt{2}b$	0	$\sqrt{2}2Fx$	0	0	0	0
FG b	0	-3/2Fx	0	0	0	0
GF b	0	3/2Fb-3/2Fx	0	0	0	0
GA b	0	-1/2Fb-1/2qx ²	0	0	0	0
AG b	0	Fb-Fx+1/2qx ²	0	0	0	0
FB b	0	Fb-Fx	0	0	0	0
BF b	0	-Fx	0	0	0	0
BE b	0	0	0	0	0	0
EB b	0	0	0	0	0	0
CD	elongazione asta $N_{1,cd} \epsilon_{cd} L_{cd}$				-Fb ² /EJ	
	totali				-11/12Fb ² /EJ	5/3Xb/EJ
	iperstatica $X=W_{cd}$				11/20Fb	

Sviluppi di calcolo iperstatica

$$L_{BC}^{xx} = \int_0^b (x^2/b^2) 1/EJ dx = [1/3 x^3/b^2]_0^b 1/EJ$$

$$= (1/3 b) 1/EJ = 1/3 b/EJ$$

$$L_{CB}^{xx} = \int_0^b (1 - 2x/b + x^2/b^2) 1/EJ dx = [x - x^2/b + 1/3 x^3/b^2]_0^b 1/EJ$$

$$= (b - b + 1/3 b) 1/EJ = 1/3 b/EJ$$

$$L_{CD}^{xx} = \int_0^b (1) 1/EJ dx = [x]_0^b 1/EJ$$

$$= (b) 1/EJ = b/EJ$$

$$L_{DC}^{xx} = \int_0^b (1) 1/EJ dx = [x]_0^b 1/EJ$$

$$= (b) 1/EJ = b/EJ$$

$$L_{DE}^{xx} = \int_0^b (1 - 2x/b + x^2/b^2) 1/EJ dx = [x - x^2/b + 1/3 x^3/b^2]_0^b 1/EJ$$

$$= (b - b + 1/3 b) 1/EJ = 1/3 b/EJ$$

$$L_{ED}^{xx} = \int_0^b (x^2/b^2) 1/EJ dx = [1/3 x^3/b^2]_0^b 1/EJ$$

$$= (1/3 b) 1/EJ = 1/3 b/EJ$$

$$L_{BC}^{xo} = \int_0^b (3/2 x/b - 1/2 x^2/b^2) Fb 1/EJ dx = [3/4 x^2/b - 1/6 x^3/b^2]_0^b Fb 1/EJ$$

$$= (3/4 b - 1/6 b) Fb 1/EJ = 7/12 Fb^2/EJ$$

$$L_{CB}^{xo} = \int_0^b (1 - 1/2 x/b - 1/2 x^2/b^2) Fb 1/EJ dx = [x - 1/4 x^2/b - 1/6 x^3/b^2]_0^b Fb 1/EJ$$

$$= (b - 1/4 b - 1/6 b) Fb 1/EJ = 7/12 Fb^2/EJ$$

$$L_{CD}^{xo} = \int_0^b (-x/b + 1/2 x^2/b^2) Fb 1/EJ dx + 1 (-1) 1 Fb^2/EJ$$

$$= [-1/2 x^2/b + 1/6 x^3/b^2]_0^b Fb 1/EJ + 1 (-1) 1 Fb^2/EJ$$

$$= (-1/2 b + 1/6 b) Fb 1/EJ + 1 (-1) 1 Fb^2/EJ = -4/3 Fb^2/EJ$$

$$L_{DC}^{xo} = \int_0^b (-1/2 + 1/2 x^2/b^2) Fb 1/EJ dx + 1 (-1) 1 Fb^2/EJ$$

$$= [-1/2 x + 1/6 x^3/b^2]_0^b Fb 1/EJ + 1 (-1) 1 Fb^2/EJ$$

$$= (-1/2 b + 1/6 b) Fb 1/EJ + 1 (-1) 1 Fb^2/EJ = -4/3 Fb^2/EJ$$

$$L_{DE}^{xo} = \int_0^b (-1/2 + x/b - 1/2 x^2/b^2) Fb 1/EJ dx = [-1/2 x + 1/2 x^2/b - 1/6 x^3/b^2]_0^b Fb 1/EJ$$

$$= (-1/2 b + 1/2 b - 1/6 b) Fb 1/EJ = -1/6 Fb^2/EJ$$

$$L_{ED}^{xo} = \int_0^b (-1/2 x^2/b^2) Fb 1/EJ dx = [-1/6 x^3/b^2]_0^b Fb 1/EJ$$

$$= (-1/6 b) Fb 1/EJ = -1/6 Fb^2/EJ$$

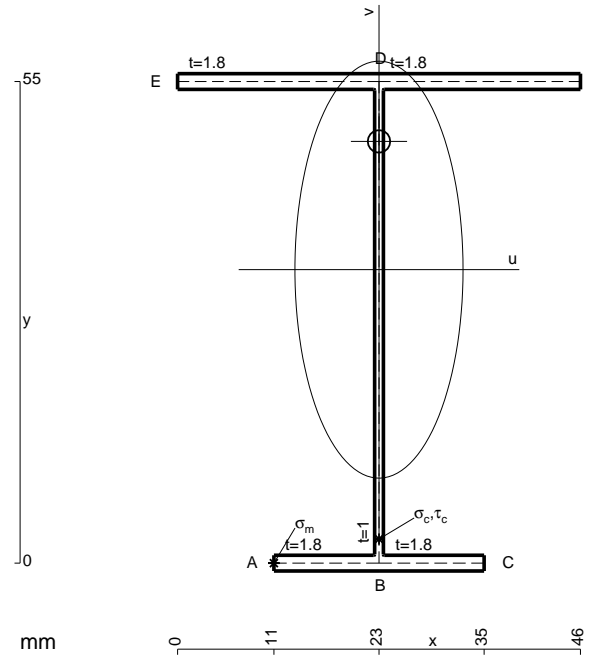

$A = 181. \text{ mm}^2$
 $J_u = 102600. \text{ mm}^4$
 $J_v = 16674. \text{ mm}^4$
 $J_t = 154.4 \text{ mm}^4$
 $y_o = 14.64 \text{ mm}$
 $y_g = 33.52 \text{ mm}$
 $N = -680. \text{ N}$
 $T_y = -1020. \text{ N}$
 $M_x = -683400. \text{ Nmm}$
 $x_m = 11. \text{ mm}$
 $u_m = -12. \text{ mm}$
 $v_m = -33.52 \text{ mm}$
 $\sigma_m = N/A - Mv/J_u = -227. \text{ N/mm}^2$
 $x_c = 23. \text{ mm}$
 $v_c = -33.52 \text{ mm}$
 $\sigma_c = N/A - Mv/J_u = -227. \text{ N/mm}^2$
 $\tau_c = TS'/tJ_u = 14.39 \text{ N/mm}^2$
 $\tau_g = TS'/tJ_u = 14.39 \text{ N/mm}^2$
 $t_c = 680. \text{ mm}$
 $\sigma_o = \sqrt{\sigma^2 + 3\tau^2} = 228.4 \text{ N/mm}^2$

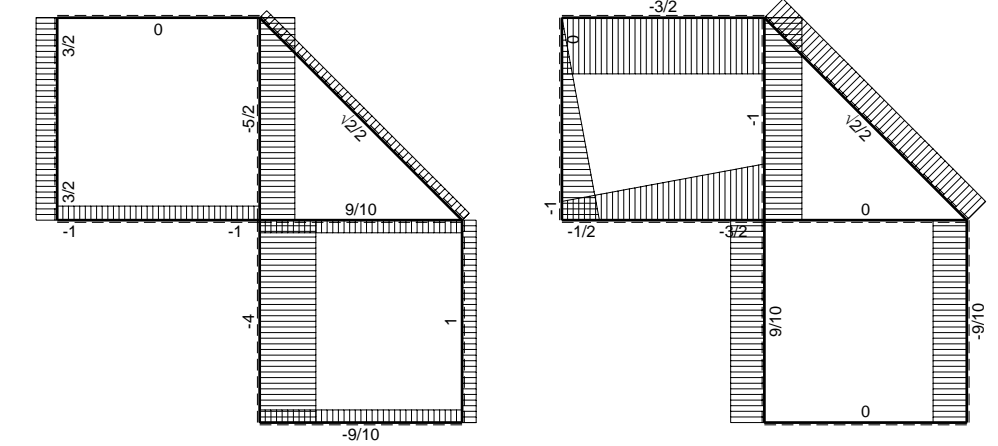
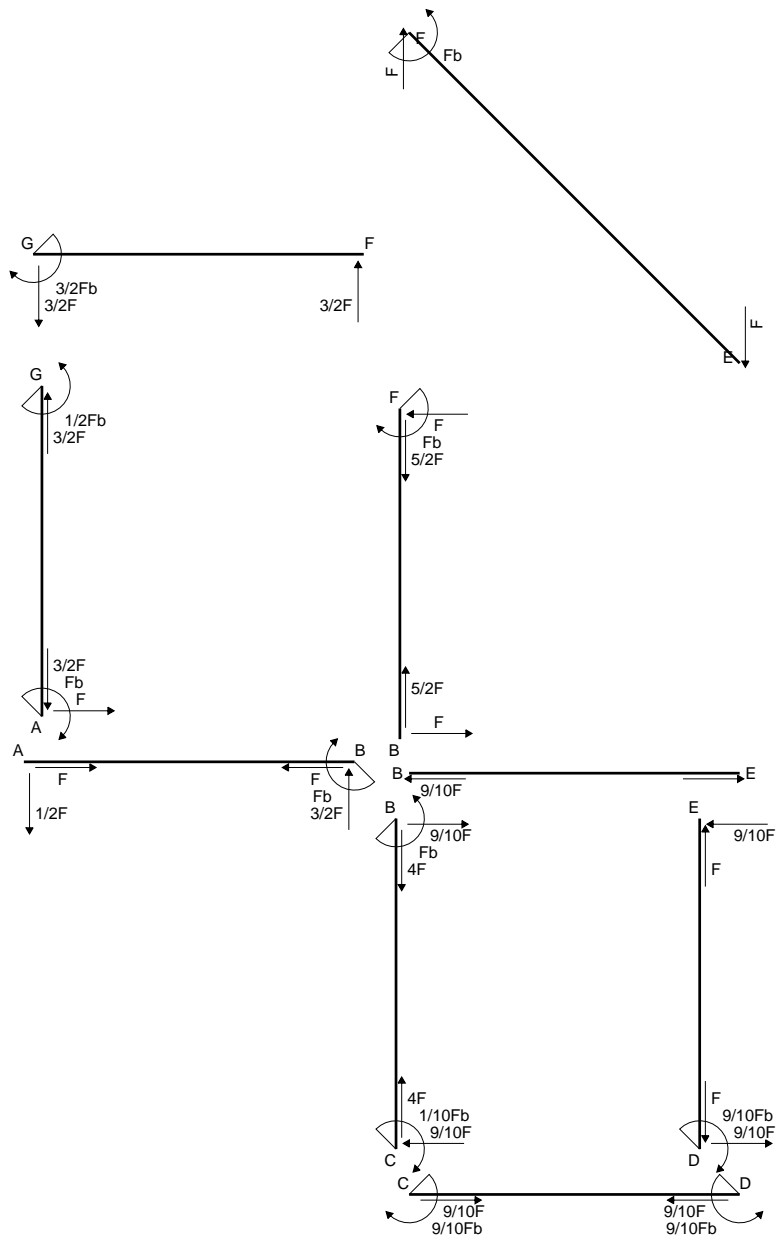

← (+) → F

↑ (+) ↓ F

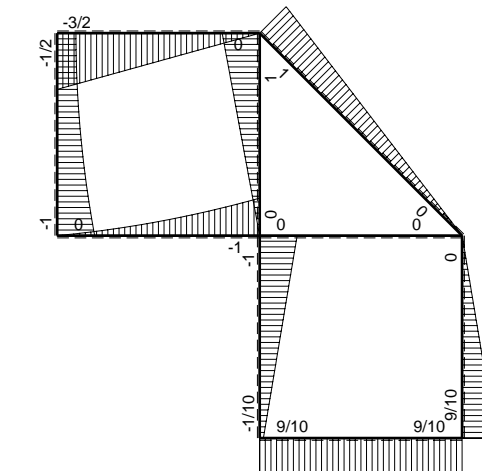

⊙ (+) ⊙ F_b

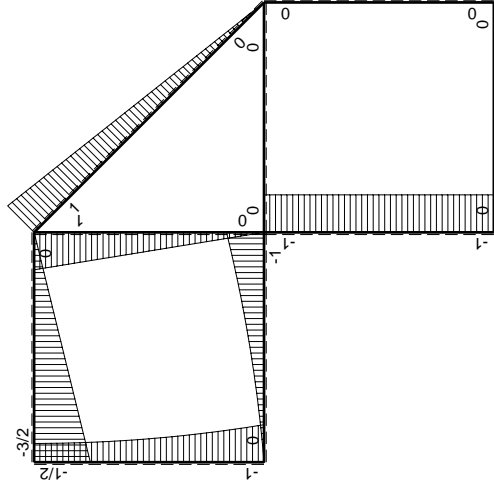
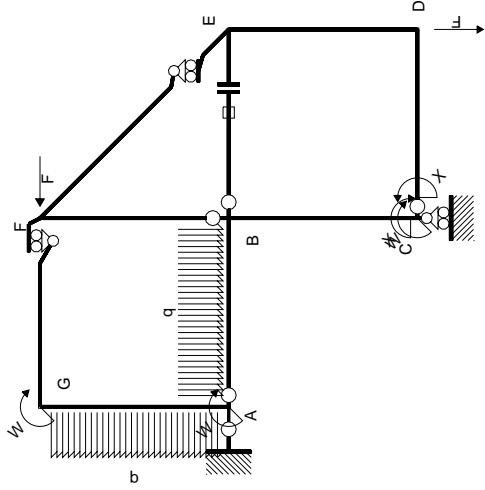

Schema di calcolo iperstatico

M_0 flessione da carichi assegnati

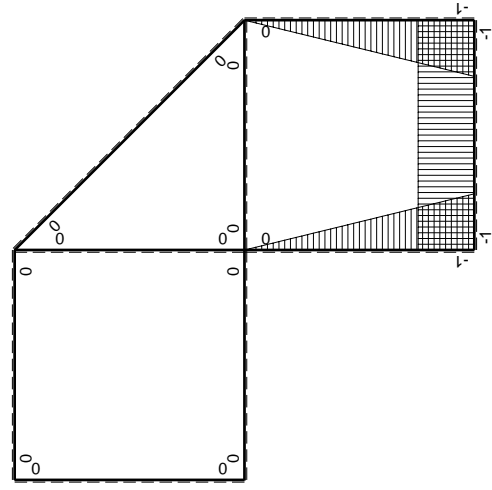

M_x flessione da iperstatica $X=1$

Quadro contribuiti PLV per iperstatica $X=W_{cd}$

\rightarrow	$M_x(x)$	$M_0(x)$	$M_x M_0$	$M_x M_x$	$\int M_x M_0 / E J dx$	$\int X M_x M_x / E J dx$
AB b	0	$-1/2Fx - 1/2qx^2$	0	0	0	0
BA b	0	$Fb - 3/2Fx + 1/2qx^2$	0	0	0	0
BC b	$-x/b$	$-Fb$	Fx	x^2/b^2	$1/2Fb^2/EJ$	$1/3Xb/EJ$
CB b	$1-x/b$	Fb	$Fb-Fx$	$1-2x/b+x^2/b^2$		
CD b	-1	0	0	1	0	Xb/EJ
DC b	1	0	0	1	0	
DE b	$-1+x/b$	0	0	$1-2x/b+x^2/b^2$	0	$1/3Xb/EJ$
ED b	x/b	0	0	x^2/b^2	0	0
EF $\sqrt{2}b$	0	$\sqrt{2}/2Fx$	0	0	0	0
FG b	0	$-3/2Fx$	0	0	0	0
GF b	0	$3/2Fb - 3/2Fx$	0	0	0	0
GA b	0	$-1/2Fb - 1/2qx^2$	0	0	0	0
AG b	0	$Fb-Fx + 1/2qx^2$	0	0	0	0
FB b	0	$Fb-Fx$	0	0	0	0
BF b	0	$-Fx$	0	0	0	0
BE b	0	0	0	0	0	0
EB b	0	0	0	0	0	0
BE	elongazione asta $N_{1, BE} \epsilon_{BE} L_{BE}$				Fb^2/EJ	
	totali				$3/2Fb^2/EJ$	$5/3Xb/EJ$
	iperstatica $X=W_{cd}$				$-9/10Fb$	

Sviluppi di calcolo iperstatica

$$L_{BC}^{xx} = \int_0^b (x^2/b^2) 1/EJ dx = [1/3 x^3/b^2]_0^b 1/EJ$$

$$= (1/3 b) 1/EJ = 1/3 b/EJ$$

$$L_{CB}^{xx} = \int_0^b (1 - 2x/b + x^2/b^2) 1/EJ dx = [x - x^2/b + 1/3 x^3/b^2]_0^b 1/EJ$$

$$= (b - b + 1/3 b) 1/EJ = 1/3 b/EJ$$

$$L_{CD}^{xx} = \int_0^b (1) 1/EJ dx = [x]_0^b 1/EJ$$

$$= (b) 1/EJ = b/EJ$$

$$L_{DC}^{xx} = \int_0^b (1) 1/EJ dx = [x]_0^b 1/EJ$$

$$= (b) 1/EJ = b/EJ$$

$$L_{DE}^{xx} = \int_0^b (1 - 2x/b + x^2/b^2) 1/EJ dx = [x - x^2/b + 1/3 x^3/b^2]_0^b 1/EJ$$

$$= (b - b + 1/3 b) 1/EJ = 1/3 b/EJ$$

$$L_{ED}^{xx} = \int_0^b (x^2/b^2) 1/EJ dx = [1/3 x^3/b^2]_0^b 1/EJ$$

$$= (1/3 b) 1/EJ = 1/3 b/EJ$$

$$L_{BC}^{xo} = \int_0^b (x/b) Fb 1/EJ dx = [1/2 x^2/b]_0^b Fb 1/EJ$$

$$= (1/2 b) Fb 1/EJ = 1/2 Fb^2/EJ$$

$$L_{CB}^{xo} = \int_0^b (1 - x/b) Fb 1/EJ dx = [x - 1/2 x^2/b]_0^b Fb 1/EJ$$

$$= (b - 1/2 b) Fb 1/EJ = 1/2 Fb^2/EJ$$

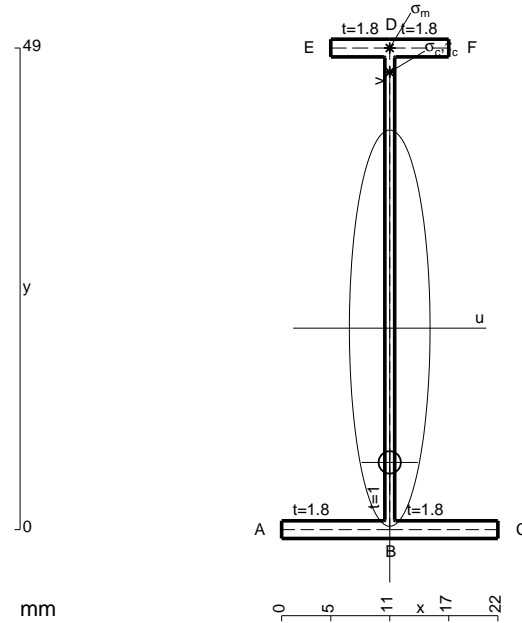

- A = 110.2 mm²
- J_u = 44775. mm⁴
- J_v = 1856. mm⁴
- J_i = 82.43 mm⁴
- y_o = -13.66 mm
- y_g = 20.5 mm
- T_y = -585. N
- M_x = -374400. Nmm
- x_m = 11. mm
- y_m = 49. mm
- v_m = 28.5 mm
- σ_m = -Mv/J_u = 238.3 N/mm²
- y_c = 2. mm
- u_c = -11. mm
- v_c = -18.5 mm
- σ_c = -Mv/J_u = 238.3 N/mm²
- τ_c = TS_y/tJ_u = 8.044 N/mm²
- τ_g = TS_y/tJ_u = 8.044 N/mm²
- t_c = 390. mm
- σ_o = √σ²+3τ² = 238.7 N/mm²

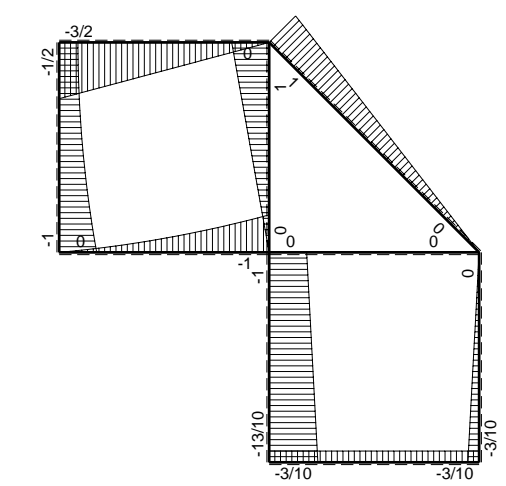
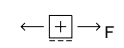
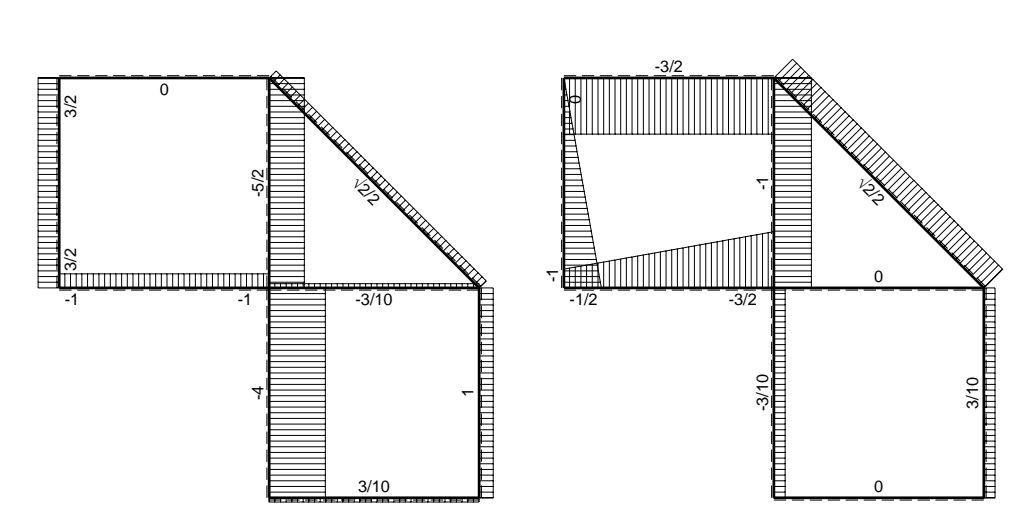
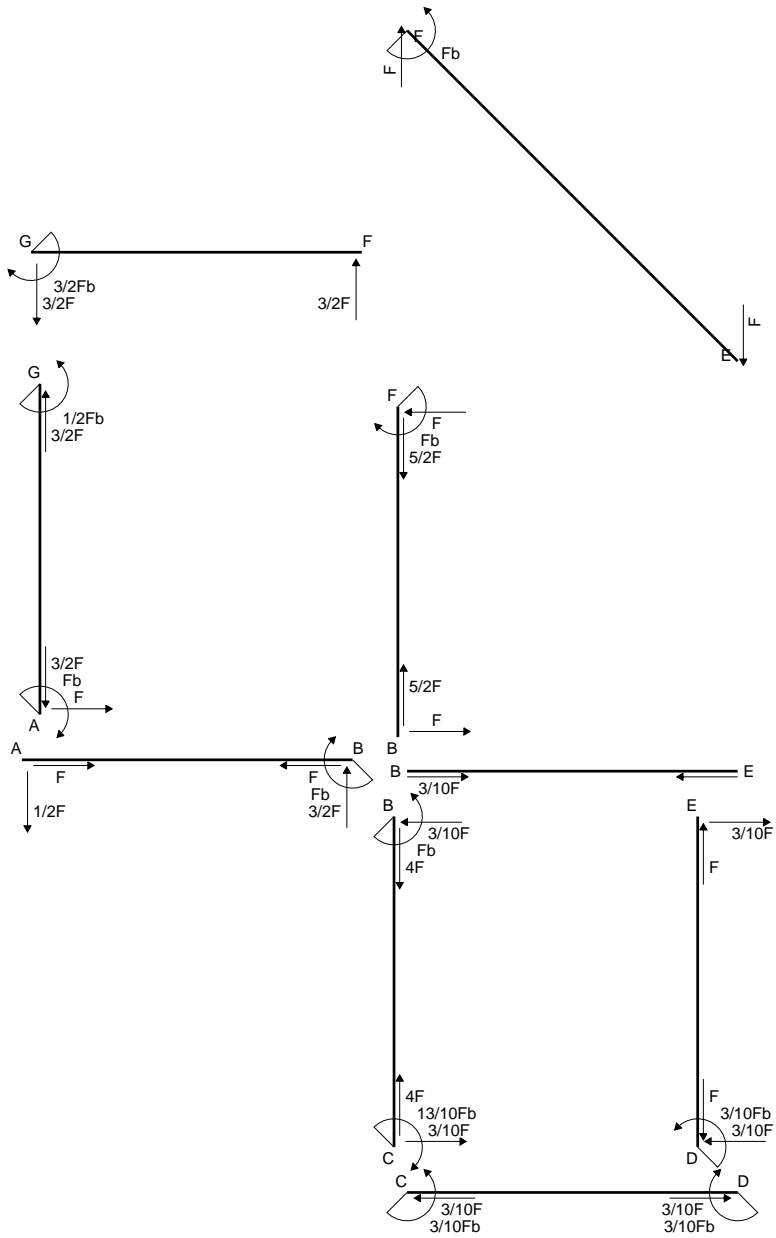

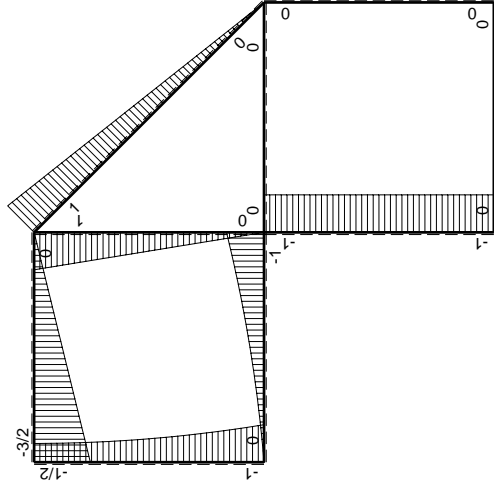
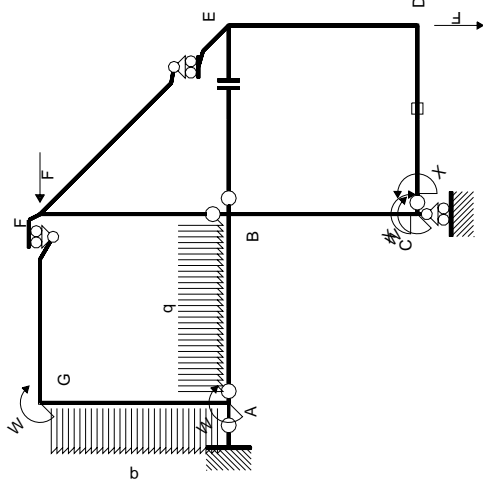

Schema di calcolo iperstatico

M_0 flessione da carichi assegnati

M_x flessione da iperstatica $X=1$

Quadro contributi PLV per iperstatica $X=W_{cd}$

\rightarrow	$M_x(x)$	$M_0(x)$	$M_x M_0$	$M_x M_x$	$\int M_x M_0 / E J dx$	$\int X M_x M_x / E J dx$
AB b	0	$-1/2Fx - 1/2qx^2$	0	0	0	0
BA b	0	$Fb - 3/2Fx + 1/2qx^2$	0	0	0	0
BC b	$-x/b$	$-Fb$	Fx	x^2/b^2	$1/2Fb^2/EJ$	$1/3Xb/EJ$
CB b	$1-x/b$	Fb	$Fb-Fx$	$1-2x/b+x^2/b^2$		
CD b	-1	0	0	1	0	Xb/EJ
DC b	1	0	0	1	0	
DE b	$-1+x/b$	0	0	$1-2x/b+x^2/b^2$	0	$1/3Xb/EJ$
ED b	x/b	0	0	x^2/b^2	0	0
EF $\sqrt{2}b$	0	$\sqrt{2}/2Fx$	0	0	0	0
FG b	0	$-3/2Fx$	0	0	0	0
GF b	0	$3/2Fb - 3/2Fx$	0	0	0	0
GA b	0	$-1/2Fb - 1/2qx^2$	0	0	0	0
AG b	0	$Fb-Fx + 1/2qx^2$	0	0	0	0
FB b	0	$Fb-Fx$	0	0	0	0
BF b	0	$-Fx$	0	0	0	0
BE b	0	0	0	0	0	0
EB b	0	0	0	0	0	0
CD	elongazione asta $N_{1,cd} \epsilon_{cd} L_{cd}$				$-Fb^2/EJ$	
	totali				$-1/2Fb^2/EJ$	$5/3Xb/EJ$
	iperstatica $X=W_{cd}$				$3/10Fb$	

Sviluppi di calcolo iperstatica

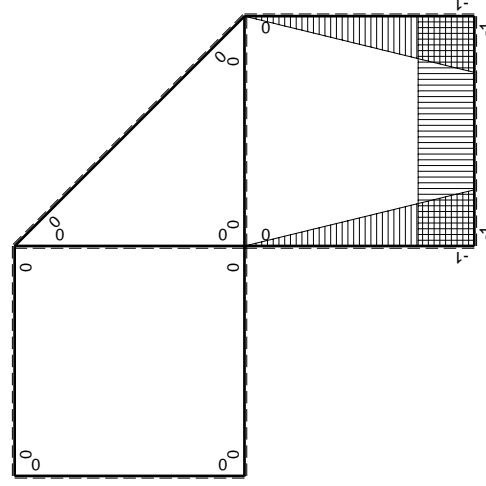

$$L_{BC}^{xx} = \int_0^b (x^2/b^2) 1/EJ dx = [1/3 x^3/b^2]_0^b 1/EJ$$

$$= (1/3 b) 1/EJ = 1/3 b/EJ$$

$$L_{CB}^{xx} = \int_0^b (1 - 2x/b + x^2/b^2) 1/EJ dx = [x - x^2/b + 1/3 x^3/b^2]_0^b 1/EJ$$

$$= (b - b + 1/3 b) 1/EJ = 1/3 b/EJ$$

$$L_{CD}^{xx} = \int_0^b (1) 1/EJ dx = [x]_0^b 1/EJ$$

$$= (b) 1/EJ = b/EJ$$

$$L_{DC}^{xx} = \int_0^b (1) 1/EJ dx = [x]_0^b 1/EJ$$

$$= (b) 1/EJ = b/EJ$$

$$L_{DE}^{xx} = \int_0^b (1 - 2x/b + x^2/b^2) 1/EJ dx = [x - x^2/b + 1/3 x^3/b^2]_0^b 1/EJ$$

$$= (b - b + 1/3 b) 1/EJ = 1/3 b/EJ$$

$$L_{ED}^{xx} = \int_0^b (x^2/b^2) 1/EJ dx = [1/3 x^3/b^2]_0^b 1/EJ$$

$$= (1/3 b) 1/EJ = 1/3 b/EJ$$

$$L_{BC}^{x_0} = \int_0^b (x/b) Fb 1/EJ dx = [1/2 x^2/b]_0^b Fb 1/EJ$$

$$= (1/2 b) Fb 1/EJ = 1/2 Fb^2/EJ$$

$$L_{CB}^{x_0} = \int_0^b (1 - x/b) Fb 1/EJ dx = [x - 1/2 x^2/b]_0^b Fb 1/EJ$$

$$= (b - 1/2 b) Fb 1/EJ = 1/2 Fb^2/EJ$$

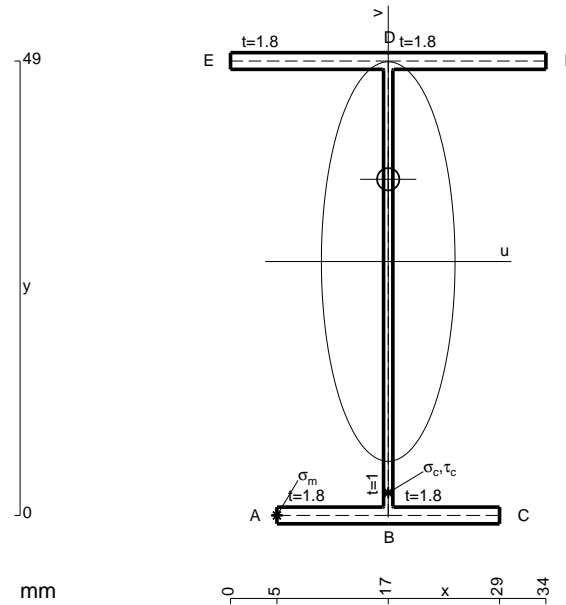

- A = 153.4 mm²
- J_u = 71202. mm⁴
- J_v = 7969. mm⁴
- J_i = 129.1 mm⁴
- y_o = 8.875 mm
- y_g = 27.37 mm
- T_y = -750. N
- M_x = -517500. Nmm
- x_m = 5. mm
- u_m = -12. mm
- v_m = -27.37 mm
- σ_m = -Mv/J_u = -199. N/mm²
- x_c = 17. mm
- v_c = -27.37 mm
- σ_c = -Mv/J_u = -199. N/mm²
- τ_c = TS'/tJ_u = 12.46 N/mm²
- τ_g = TS'/tJ_u = 12.46 N/mm²
- t_c = 500. mm
- σ_o = √σ²+3τ² = 200.1 N/mm²

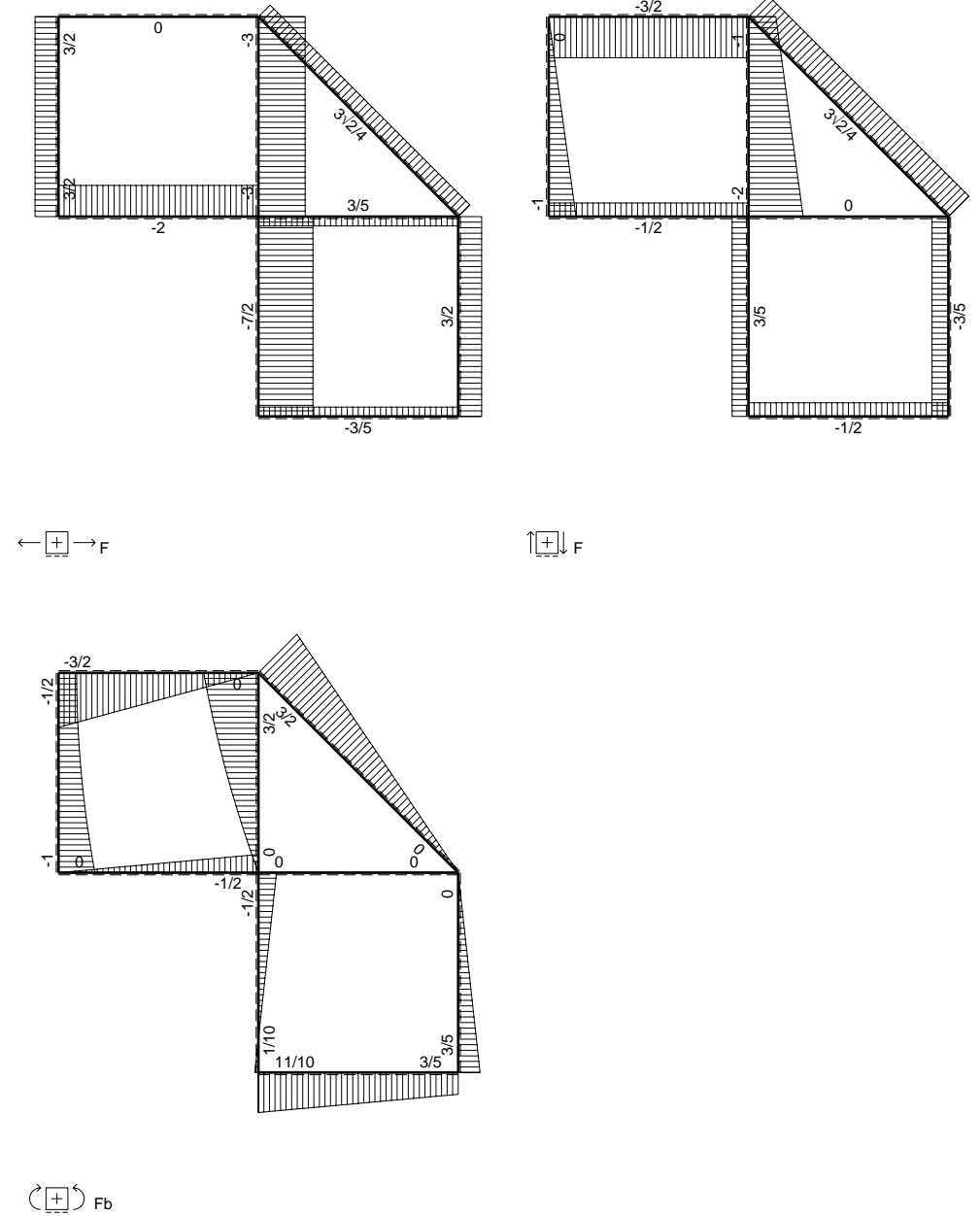
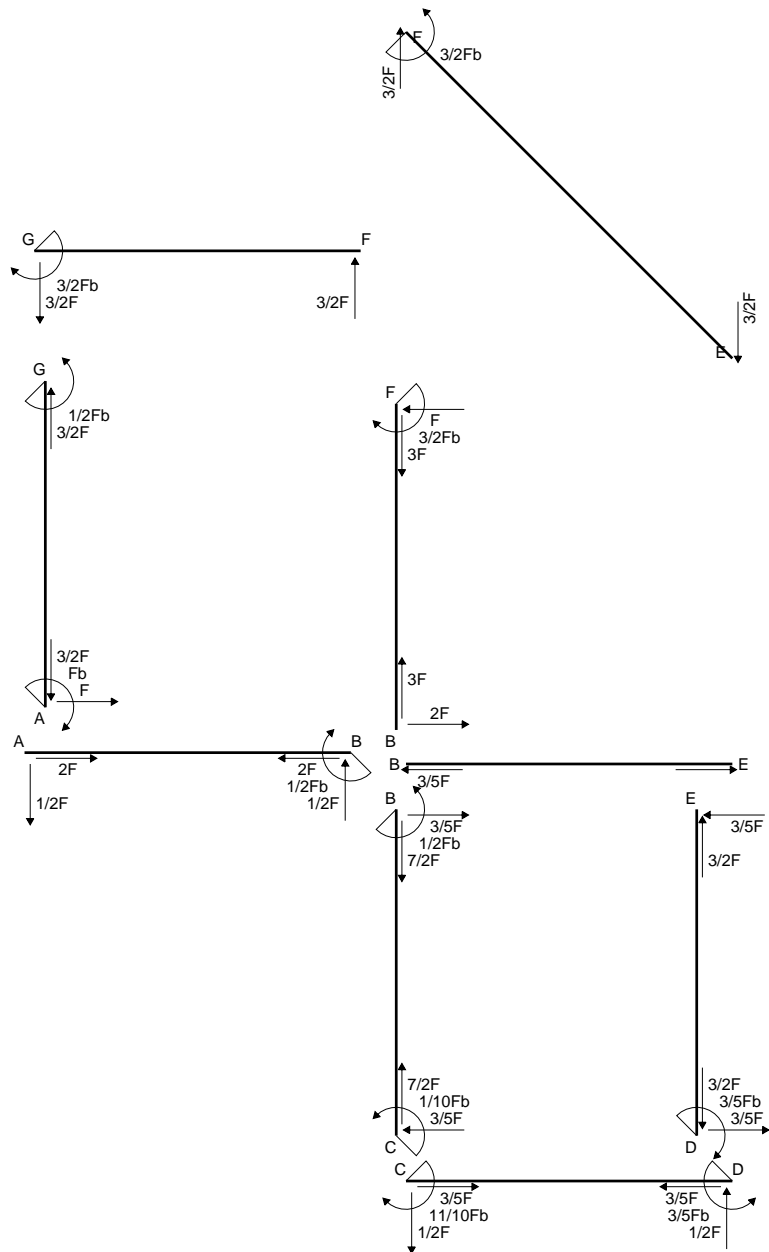

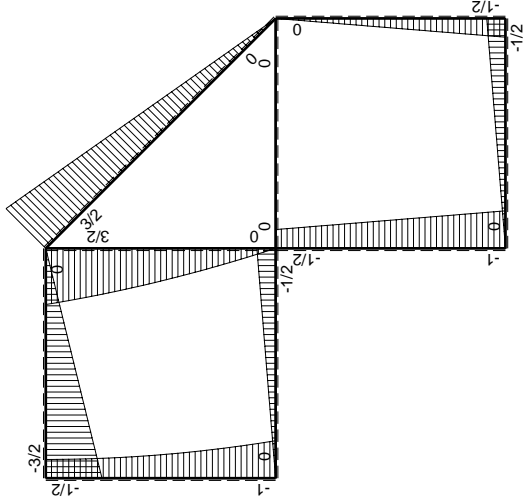
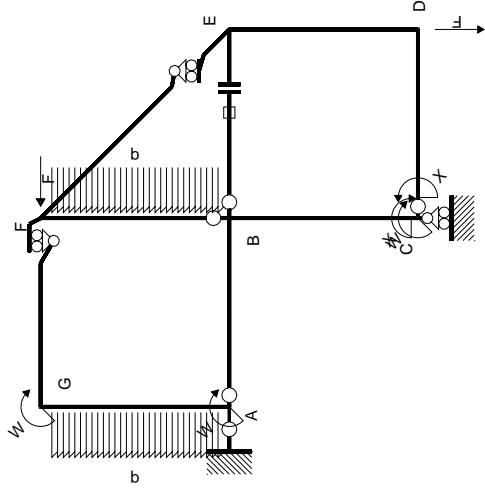

Schema di calcolo iperstatico

M_0 flessione da carichi assegnati

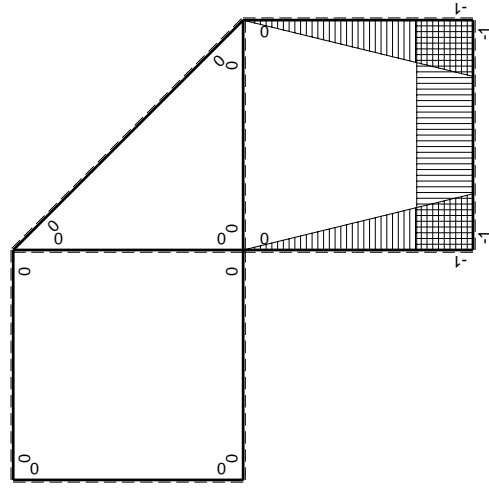

M_x flessione da iperstatica $X=1$

Quadro contribuiti PLV per iperstatica $X=W_{cd}$

\rightarrow	$M_x(x)$	$M_0(x)$	$M_x M_0$	$M_x M_x$	$\int M_x M_0 / EJ dx$	$\int M_x M_x / EJ dx$
AB b	0	$-1/2Fx$	0	0	0	0
BA b	0	$1/2Fb-1/2Fx$	0	0	0	0
BC b	$-x/b$	$-1/2Fb-1/2Fx$	$1/2Fx+1/2Fx^2/b$	x^2/b^2	$5/12Fb^2/EJ$	$1/3xb/EJ$
CB b	$1-x/b$	$Fb-1/2Fx$	$Fb-3/2Fx+1/2Fx^2/b$	$1-2x/b+x^2/b^2$	$1/4Fb^2/EJ$	Xb/EJ
CD b	-1	$-1/2Fx$	$1/2Fx$	1	$1/6Fb^2/EJ$	$1/3xb/EJ$
DC b	1	$1/2Fb-1/2Fx$	$1/2Fb-1/2Fx$	1	$1/6Fb^2/EJ$	0
DE b	$-1+x/b$	$-1/2Fb+1/2Fx$	$1/2Fb-Fx+1/2Fx^2/b$	$1-2x/b+x^2/b^2$	0	0
ED b	x/b	$1/2Fx$	$1/2Fx^2/b$	x^2/b^2	0	0
EF $\sqrt{2}b$	0	$3\sqrt{2}/4Fx$	0	0	0	0
FG b	0	$-3/2Fx$	0	0	0	0
GF b	0	$3/2Fb-3/2Fx$	0	0	0	0
GA b	0	$-1/2Fb-1/2qx^2$	0	0	0	0
AG b	0	$Fb-Fx+1/2qx^2$	0	0	0	0
FB b	0	$3/2Fb-Fx-1/2qx^2$	0	0	0	0
BF b	0	$-2Fx+1/2qx^2$	0	0	0	0
BE b	0	0	0	0	0	0
EB b	0	0	0	0	0	0
BE	elongazione asta $N_{1, BE}^{\epsilon_{BE}} L_{BE}$				Fb^2/EJ	$5/3xb/EJ$
	totali				$11/6Fb^2/EJ$	$1/3xb/EJ$
	iperstatica $X=W_{cd}$				$-11/10Fb$	

Sviluppi di calcolo iperstatica

$$L_{BC}^{xx} = \int_0^b (x^2/b^2) 1/EJ dx = [1/3 x^3/b^2]_0^b 1/EJ$$

$$= (1/3 b) 1/EJ = 1/3 b/EJ$$

$$L_{CB}^{xx} = \int_0^b (1 - 2x/b + x^2/b^2) 1/EJ dx = [x - x^2/b + 1/3 x^3/b^2]_0^b 1/EJ$$

$$= (b - b + 1/3 b) 1/EJ = 1/3 b/EJ$$

$$L_{CD}^{xx} = \int_0^b (1) 1/EJ dx = [x]_0^b 1/EJ$$

$$= (b) 1/EJ = b/EJ$$

$$L_{DC}^{xx} = \int_0^b (1) 1/EJ dx = [x]_0^b 1/EJ$$

$$= (b) 1/EJ = b/EJ$$

$$L_{DE}^{xx} = \int_0^b (1 - 2x/b + x^2/b^2) 1/EJ dx = [x - x^2/b + 1/3 x^3/b^2]_0^b 1/EJ$$

$$= (b - b + 1/3 b) 1/EJ = 1/3 b/EJ$$

$$L_{ED}^{xx} = \int_0^b (x^2/b^2) 1/EJ dx = [1/3 x^3/b^2]_0^b 1/EJ$$

$$= (1/3 b) 1/EJ = 1/3 b/EJ$$

$$L_{BC}^{x_0} = \int_0^b (1/2 x/b + 1/2 x^2/b^2) Fb 1/EJ dx = [1/4 x^2/b + 1/6 x^3/b^2]_0^b Fb 1/EJ$$

$$= (1/4 b + 1/6 b) Fb 1/EJ = 5/12 Fb^2/EJ$$

$$L_{CB}^{x_0} = \int_0^b (1 - 3/2 x/b + 1/2 x^2/b^2) Fb 1/EJ dx = [x - 3/4 x^2/b + 1/6 x^3/b^2]_0^b Fb 1/EJ$$

$$= (b - 3/4 b + 1/6 b) Fb 1/EJ = 5/12 Fb^2/EJ$$

$$L_{CD}^{x_0} = \int_0^b (1/2 x/b) Fb 1/EJ dx = [1/4 x^2/b]_0^b Fb 1/EJ$$

$$= (1/4 b) Fb 1/EJ = 1/4 Fb^2/EJ$$

$$L_{DC}^{x_0} = \int_0^b (1/2 - 1/2 x/b) Fb 1/EJ dx = [1/2 x - 1/4 x^2/b]_0^b Fb 1/EJ$$

$$= (1/2 b - 1/4 b) Fb 1/EJ = 1/4 Fb^2/EJ$$

$$L_{DE}^{x_0} = \int_0^b (1/2 - x/b + 1/2 x^2/b^2) Fb 1/EJ dx = [1/2 x - 1/2 x^2/b + 1/6 x^3/b^2]_0^b Fb 1/EJ$$

$$= (1/2 b - 1/2 b + 1/6 b) Fb 1/EJ = 1/6 Fb^2/EJ$$

$$L_{ED}^{x_0} = \int_0^b (1/2 x^2/b^2) Fb 1/EJ dx = [1/6 x^3/b^2]_0^b Fb 1/EJ$$

$$= (1/6 b) Fb 1/EJ = 1/6 Fb^2/EJ$$

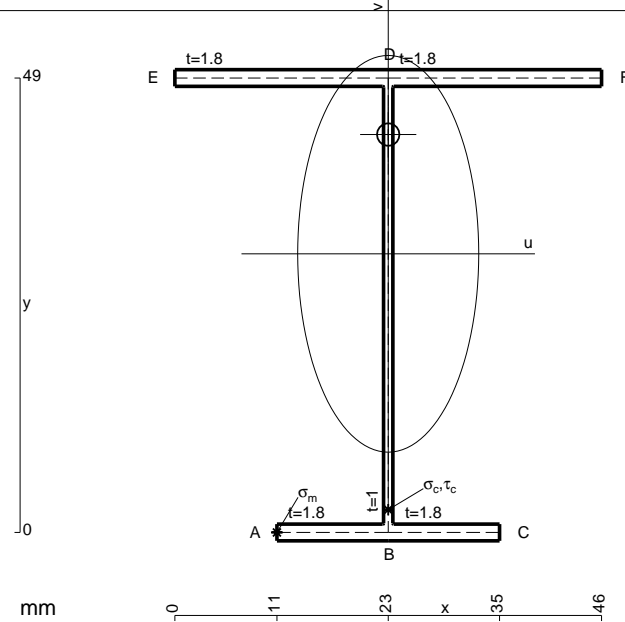

- A = 175. mm²
- J_u = 80057. mm⁴
- J_v = 16674. mm⁴
- J_i = 152.4 mm⁴
- y_o = 12.86 mm
- y_g = 30.04 mm
- T_y = -765. N
- M_x = -558450. Nmm
- x_m = 11. mm
- u_m = -12. mm
- v_m = -30.04 mm
- σ_m = -Mv/J_u = -209.6 N/mm²
- x_c = 23. mm
- v_c = -30.04 mm
- σ_c = -Mv/J_u = -209.6 N/mm²
- τ_c = TS_v/tJ_u = 12.4 N/mm²
- τ_g = TS_v/tJ_u = 12.4 N/mm²
- t_c = 510. mm
- σ_o = √σ²+3τ² = 210.7 N/mm²

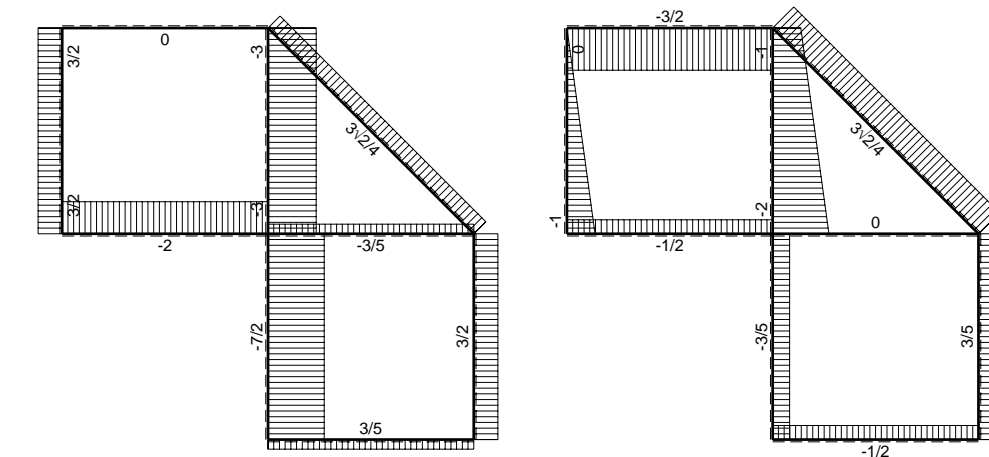
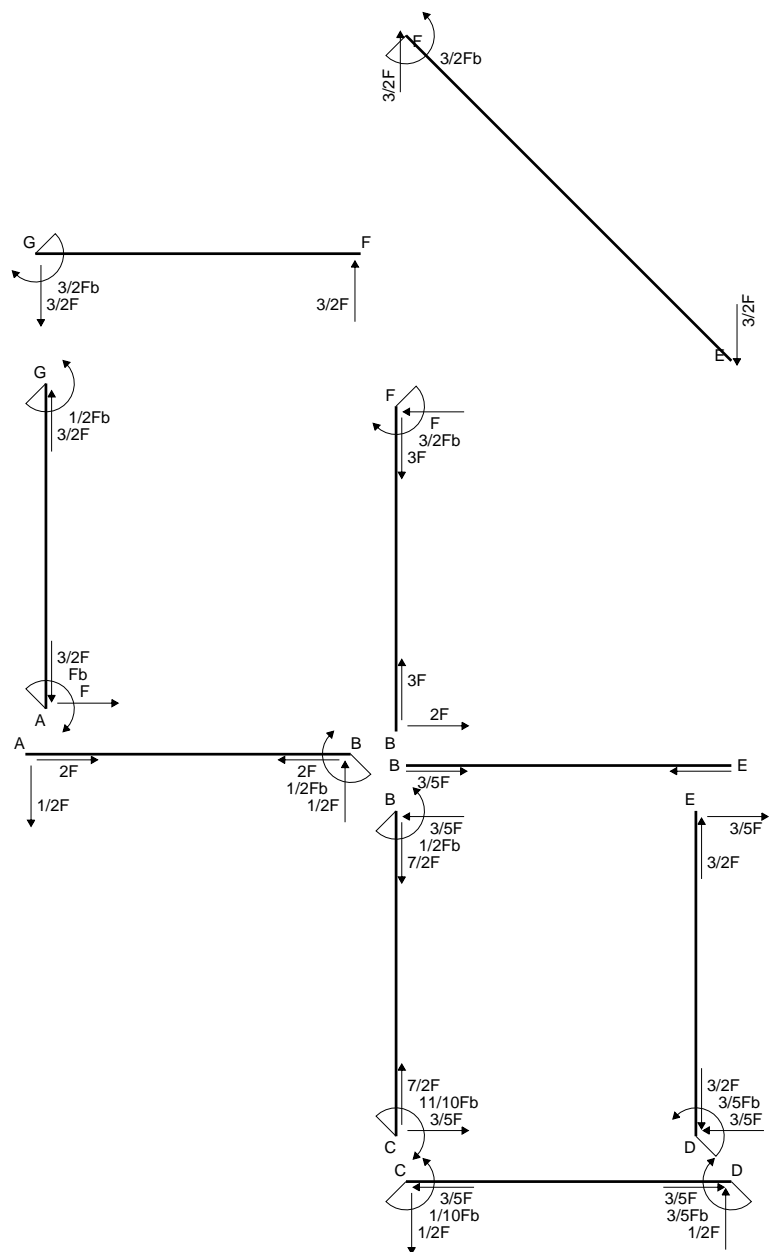

← ⊕ → F

↑ ⊕ ↓ F

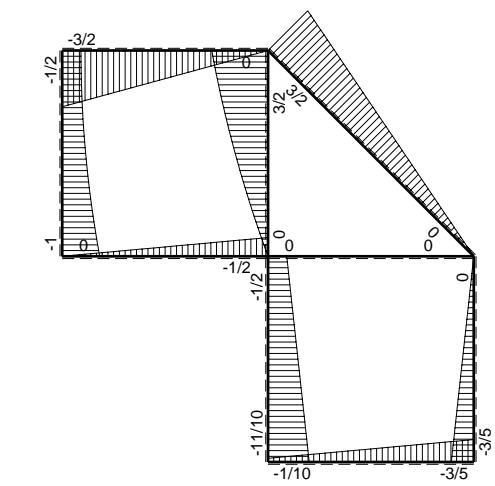

⊕ ⊖ F_b

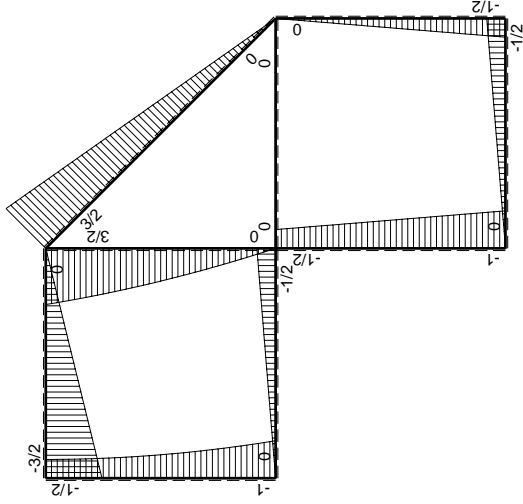
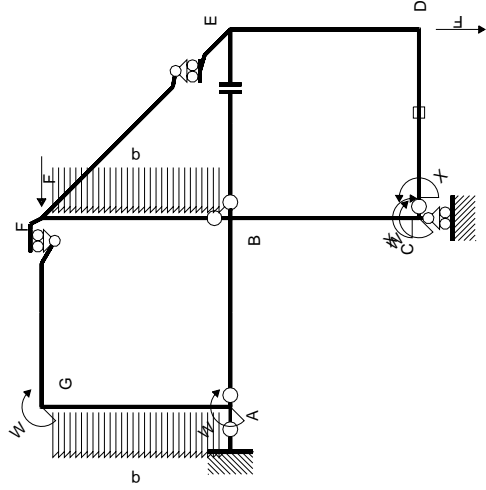

Schema di calcolo iperstatico

M_0 flessione da carichi assegnati

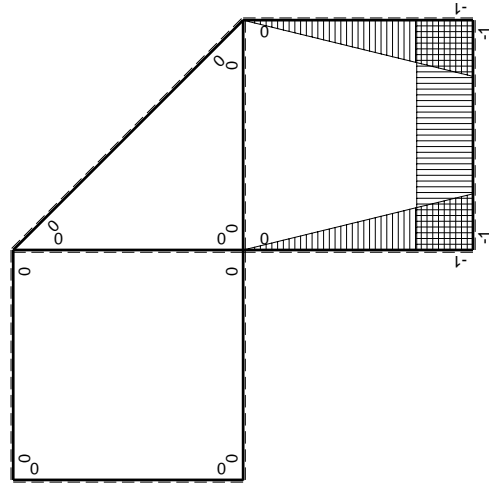

M_x flessione da iperstatica X=1

Quadro contribuiti PLV per iperstatica X=W_{cd}

→	$M_x(x)$	$M_0(x)$	$M_x M_0$	$M_x M_x$	$\int M_x M_0 / EJ dx$	$\int M_x M_x / EJ dx$
AB b	0	-1/2Fx	0	0	0	0
BA b	0	1/2Fb-1/2Fx	0	0	0	0
BC b	-x/b	-1/2Fb-1/2Fx	1/2Fx+1/2Fx ² /b	x ² /b ²	5/12Fb ² /EJ	1/3Xb/EJ
CB b	1-x/b	Fb-1/2Fx	Fb-3/2Fx+1/2Fx ² /b	1-2x/b+x ² /b ²	1/4Fb ² /EJ	Xb/EJ
CD b	-1	-1/2Fx	1/2Fx	1	1/4Fb ² /EJ	Xb/EJ
DC b	1	1/2Fb-1/2Fx	1/2Fb-1/2Fx	1	1/4Fb ² /EJ	Xb/EJ
DE b	-1+x/b	-1/2Fb+1/2Fx	1/2Fb-Fx+1/2Fx ² /b	1-2x/b+x ² /b ²	1/6Fb ² /EJ	1/3Xb/EJ
ED b	x/b	1/2Fx	1/2Fx ² /b	x ² /b ²	1/6Fb ² /EJ	1/3Xb/EJ
EF √2b	0	3√2/4Fx	0	0	0	0
FG b	0	-3/2Fx	0	0	0	0
GF b	0	3/2Fb-3/2Fx	0	0	0	0
GA b	0	-1/2Fb-1/2qx ²	0	0	0	0
AG b	0	Fb-Fx+1/2qx ²	0	0	0	0
FB b	0	3/2Fb-Fx-1/2qx ²	0	0	0	0
BF b	0	-2Fx+1/2qx ²	0	0	0	0
BE b	0	0	0	0	0	0
EB b	0	0	0	0	0	0
CD	elongazione asta $N_{1,cd} \epsilon_{cd} l_{cd}$				-Fb ² /EJ	5/3Xb/EJ
	totali				-1/6Fb ² /EJ	5/3Xb/EJ
	iperstatica X=W _{cd}				1/10Fb	

Sviluppi di calcolo iperstatica

$$L_{BC}^{xx} = \int_0^b (x^2/b^2) 1/EJ dx = [1/3 x^3/b^2]_0^b 1/EJ$$

$$= (1/3 b) 1/EJ = 1/3 b/EJ$$

$$L_{CB}^{xx} = \int_0^b (1 - 2x/b + x^2/b^2) 1/EJ dx = [x - x^2/b + 1/3 x^3/b^2]_0^b 1/EJ$$

$$= (b - b + 1/3 b) 1/EJ = 1/3 b/EJ$$

$$L_{CD}^{xx} = \int_0^b (1) 1/EJ dx = [x]_0^b 1/EJ$$

$$= (b) 1/EJ = b/EJ$$

$$L_{DC}^{xx} = \int_0^b (1) 1/EJ dx = [x]_0^b 1/EJ$$

$$= (b) 1/EJ = b/EJ$$

$$L_{DE}^{xx} = \int_0^b (1 - 2x/b + x^2/b^2) 1/EJ dx = [x - x^2/b + 1/3 x^3/b^2]_0^b 1/EJ$$

$$= (b - b + 1/3 b) 1/EJ = 1/3 b/EJ$$

$$L_{ED}^{xx} = \int_0^b (x^2/b^2) 1/EJ dx = [1/3 x^3/b^2]_0^b 1/EJ$$

$$= (1/3 b) 1/EJ = 1/3 b/EJ$$

$$L_{BC}^{xo} = \int_0^b (1/2 x/b + 1/2 x^2/b^2) Fb 1/EJ dx = [1/4 x^2/b + 1/6 x^3/b^2]_0^b Fb 1/EJ$$

$$= (1/4 b + 1/6 b) Fb 1/EJ = 5/12 Fb^2/EJ$$

$$L_{CB}^{xo} = \int_0^b (1 - 3/2 x/b + 1/2 x^2/b^2) Fb 1/EJ dx = [x - 3/4 x^2/b + 1/6 x^3/b^2]_0^b Fb 1/EJ$$

$$= (b - 3/4 b + 1/6 b) Fb 1/EJ = 5/12 Fb^2/EJ$$

$$L_{CD}^{xo} = \int_0^b (1/2 x/b) Fb 1/EJ dx + 1 (-1) 1 Fb^2/EJ = [1/4 x^2/b]_0^b Fb 1/EJ + 1 (-1) 1 Fb^2/EJ$$

$$= (1/4 b) Fb 1/EJ + 1 (-1) 1 Fb^2/EJ = -3/4 Fb^2/EJ$$

$$L_{DC}^{xo} = \int_0^b (1/2 - 1/2 x/b) Fb 1/EJ dx + 1 (-1) 1 Fb^2/EJ = [1/2 x - 1/4 x^2/b]_0^b Fb 1/EJ + 1 (-1) 1 Fb^2/EJ$$

$$= (1/2 b - 1/4 b) Fb 1/EJ + 1 (-1) 1 Fb^2/EJ = -3/4 Fb^2/EJ$$

$$L_{DE}^{xo} = \int_0^b (1/2 - x/b + 1/2 x^2/b^2) Fb 1/EJ dx = [1/2 x - 1/2 x^2/b + 1/6 x^3/b^2]_0^b Fb 1/EJ$$

$$= (1/2 b - 1/2 b + 1/6 b) Fb 1/EJ = 1/6 Fb^2/EJ$$

$$L_{ED}^{xo} = \int_0^b (1/2 x^2/b^2) Fb 1/EJ dx = [1/6 x^3/b^2]_0^b Fb 1/EJ$$

$$= (1/6 b) Fb 1/EJ = 1/6 Fb^2/EJ$$

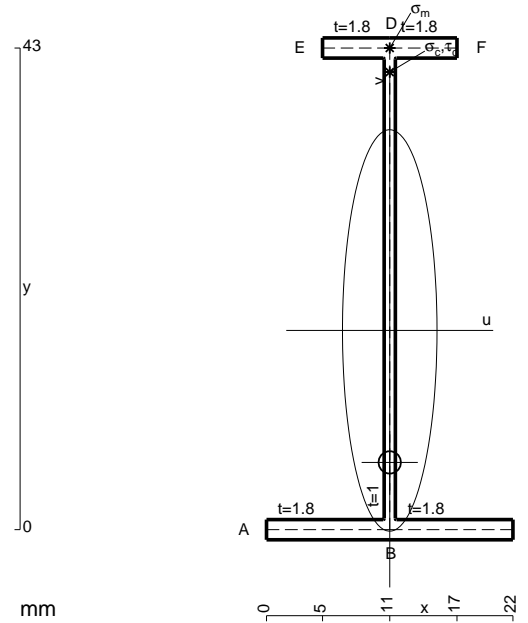

- A = 104.2 mm²
- J_u = 33478. mm⁴
- J_v = 1856. mm⁴
- J_i = 80.43 mm⁴
- y_o = -11.78 mm
- y_g = 17.79 mm
- T_y = -420. N
- M_x = -289800. Nmm
- x_m = 11. mm
- y_m = 43. mm
- v_m = 25.21 mm
- σ_m = -Mv/J_u = 218.3 N/mm²
- y_c = 2. mm
- u_c = -11. mm
- v_c = -15.79 mm
- σ_c = -Mv/J_u = 218.3 N/mm²
- τ_c = TS_y/tJ_u = 6.833 N/mm²
- τ_g = TS_y/tJ_u = 6.833 N/mm²
- t_c = 280. mm
- σ_o = √σ²+3τ² = 218.6 N/mm²

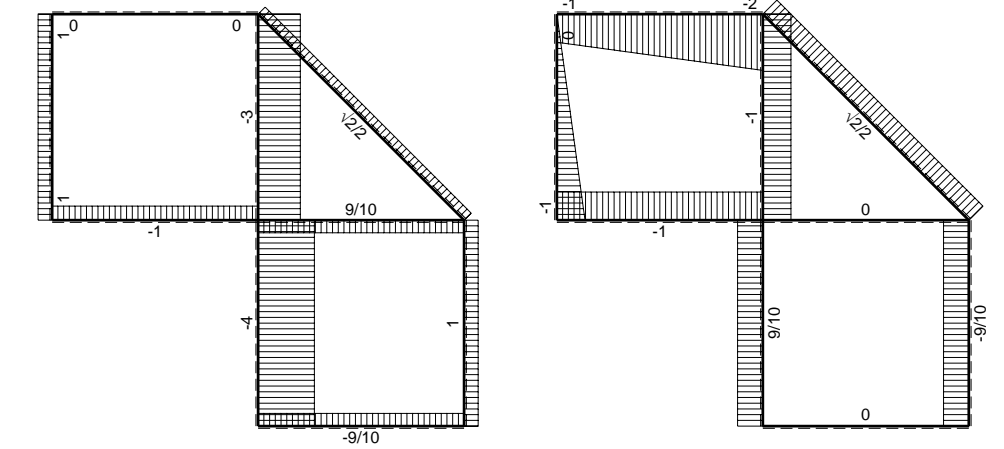
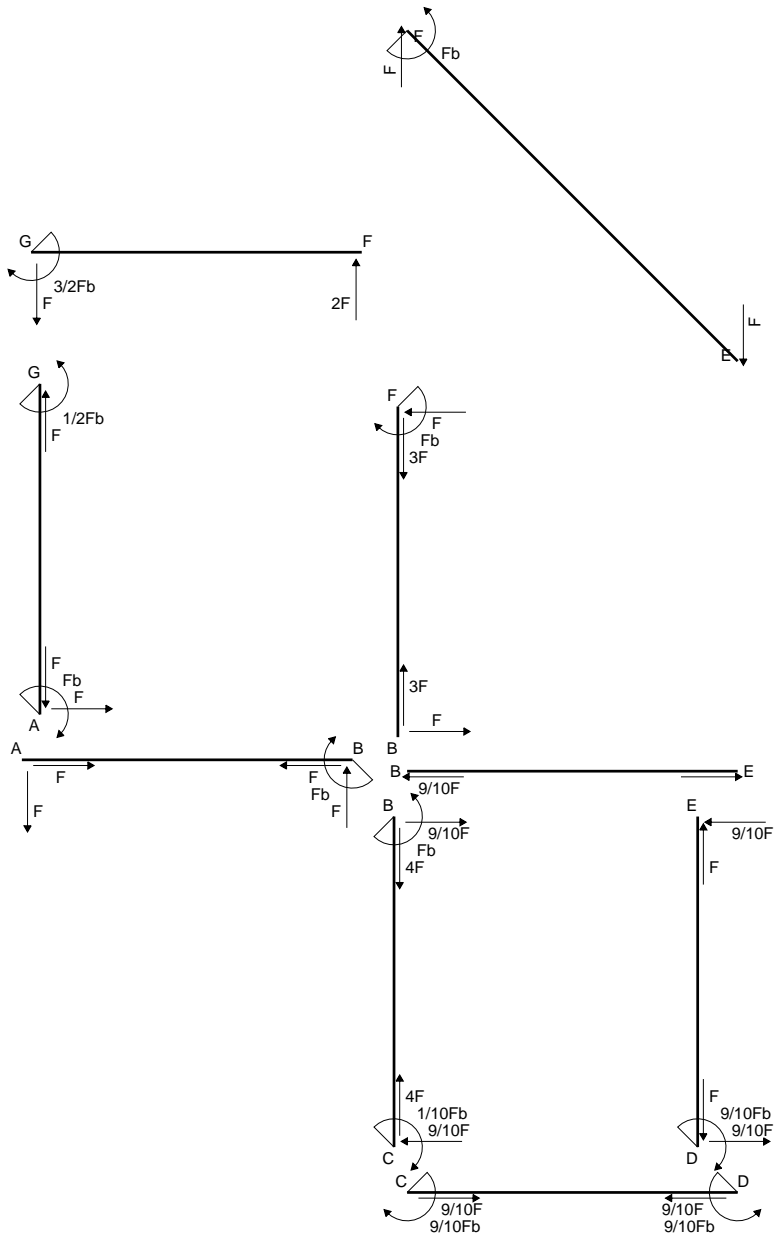

← ⊕ → F

↑ ⊕ ↓ F

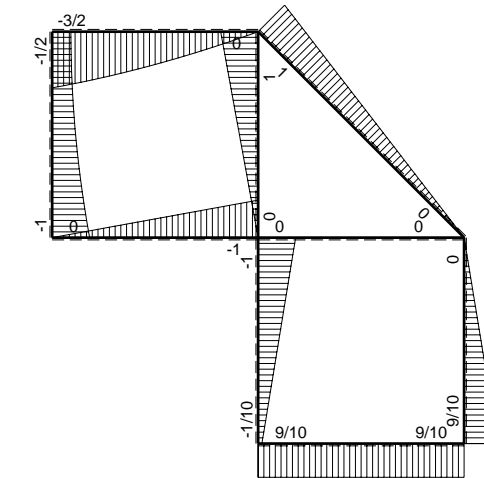

⊕ ⊖ Fb

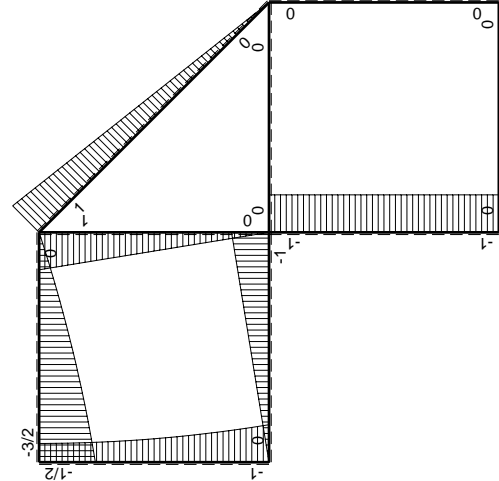
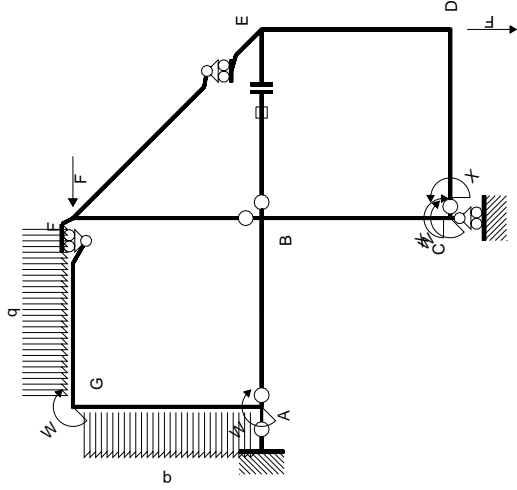

Schema di calcolo iperstatico

M_0 flessione da carichi assegnati

M_x flessione da iperstatica $X=1$

Quadro contribuiti PLV per iperstatica $X=W_{cd}$

\rightarrow	$M_x(x)$	$M_0(x)$	$M_x M_0$	$M_x M_x$	$\int M_x M_0 / EJ dx$	$\int X M_x M_x / EJ dx$
AB b	0	-Fx	0	0	0	0
BA b	0	Fb-Fx	0	0	0	0
BC b	-x/b	-Fb	Fx	x^2/b^2	$1/2 Fb^2/EJ$	$1/3 Xb/EJ$
CB b	$1-x/b$	Fb	Fb-Fx	$1-2x/b+x^2/b^2$		
CD b	-1	0	0	1	0	Xb/EJ
DC b	1	0	0	1	0	
DE b	$-1+x/b$	0	0	$1-2x/b+x^2/b^2$	0	$1/3 Xb/EJ$
ED b	x/b	0	0	x^2/b^2	0	0
EF $\sqrt{2}b$	0	$\sqrt{2}/2 Fx$	0	0	0	0
FG b	0	$-2Fx+1/2qx^2$	0	0	0	0
GF b	0	$3/2 Fb-Fx-1/2qx^2$	0	0	0	0
GA b	0	$-1/2 Fb-1/2qx^2$	0	0	0	0
AG b	0	$Fb-Fx+1/2qx^2$	0	0	0	0
FB b	0	Fb-Fx	0	0	0	0
BF b	0	-Fx	0	0	0	0
BE b	0	0	0	0	0	0
EB b	0	0	0	0	0	0
BE	elongazione asta $N_{1, BE} \epsilon_{BE} L_{BE}$				Fb^2/EJ	
	totali				$3/2 Fb^2/EJ$	$5/3 Xb/EJ$
	iperstatica $X=W_{cd}$				$-9/10 Fb$	

Sviluppi di calcolo iperstatica

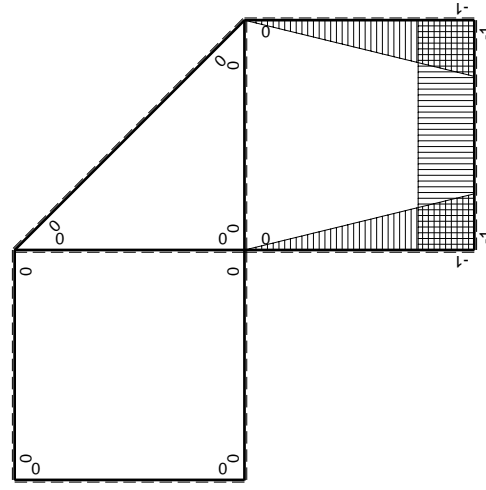

$$L_{BC}^{xx} = \int_0^b (x^2/b^2) 1/EJ dx = [1/3 x^3/b^2]_0^b 1/EJ$$

$$= (1/3 b) 1/EJ = 1/3 b/EJ$$

$$L_{CB}^{xx} = \int_0^b (1 - 2x/b + x^2/b^2) 1/EJ dx = [x - x^2/b + 1/3 x^3/b^2]_0^b 1/EJ$$

$$= (b - b + 1/3 b) 1/EJ = 1/3 b/EJ$$

$$L_{CD}^{xx} = \int_0^b (1) 1/EJ dx = [x]_0^b 1/EJ$$

$$= (b) 1/EJ = b/EJ$$

$$L_{DC}^{xx} = \int_0^b (1) 1/EJ dx = [x]_0^b 1/EJ$$

$$= (b) 1/EJ = b/EJ$$

$$L_{DE}^{xx} = \int_0^b (1 - 2x/b + x^2/b^2) 1/EJ dx = [x - x^2/b + 1/3 x^3/b^2]_0^b 1/EJ$$

$$= (b - b + 1/3 b) 1/EJ = 1/3 b/EJ$$

$$L_{ED}^{xx} = \int_0^b (x^2/b^2) 1/EJ dx = [1/3 x^3/b^2]_0^b 1/EJ$$

$$= (1/3 b) 1/EJ = 1/3 b/EJ$$

$$L_{BC}^{x_0} = \int_0^b (x/b) Fb 1/EJ dx = [1/2 x^2/b]_0^b Fb 1/EJ$$

$$= (1/2 b) Fb 1/EJ = 1/2 Fb^2/EJ$$

$$L_{CB}^{x_0} = \int_0^b (1 - x/b) Fb 1/EJ dx = [x - 1/2 x^2/b]_0^b Fb 1/EJ$$

$$= (b - 1/2 b) Fb 1/EJ = 1/2 Fb^2/EJ$$

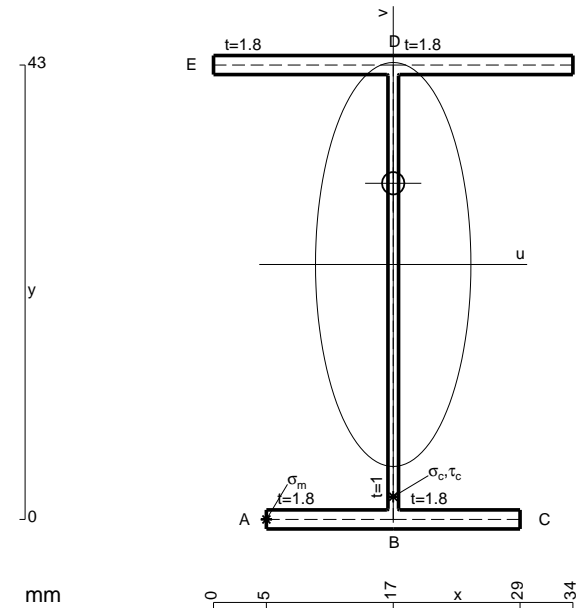

- A = 147.4 mm²
- J_u = 53868. mm⁴
- J_v = 7969. mm⁴
- J_i = 127.1 mm⁴
- y_o = 7.686 mm
- y_g = 24.13 mm
- T_y = -460. N
- M_x = -503700. Nmm
- x_m = 5. mm
- u_m = -12. mm
- v_m = -24.13 mm
- σ_m = -Mv/J_u = -225.6 N/mm²
- x_c = 17. mm
- v_c = -24.13 mm
- σ_c = -Mv/J_u = -225.6 N/mm²
- τ_c = TS'/tJ_u = 8.9 N/mm²
- τ_g = TS'/tJ_u = 8.9 N/mm²
- t_c = 460. mm
- σ_o = √σ²+3τ² = 226.1 N/mm²

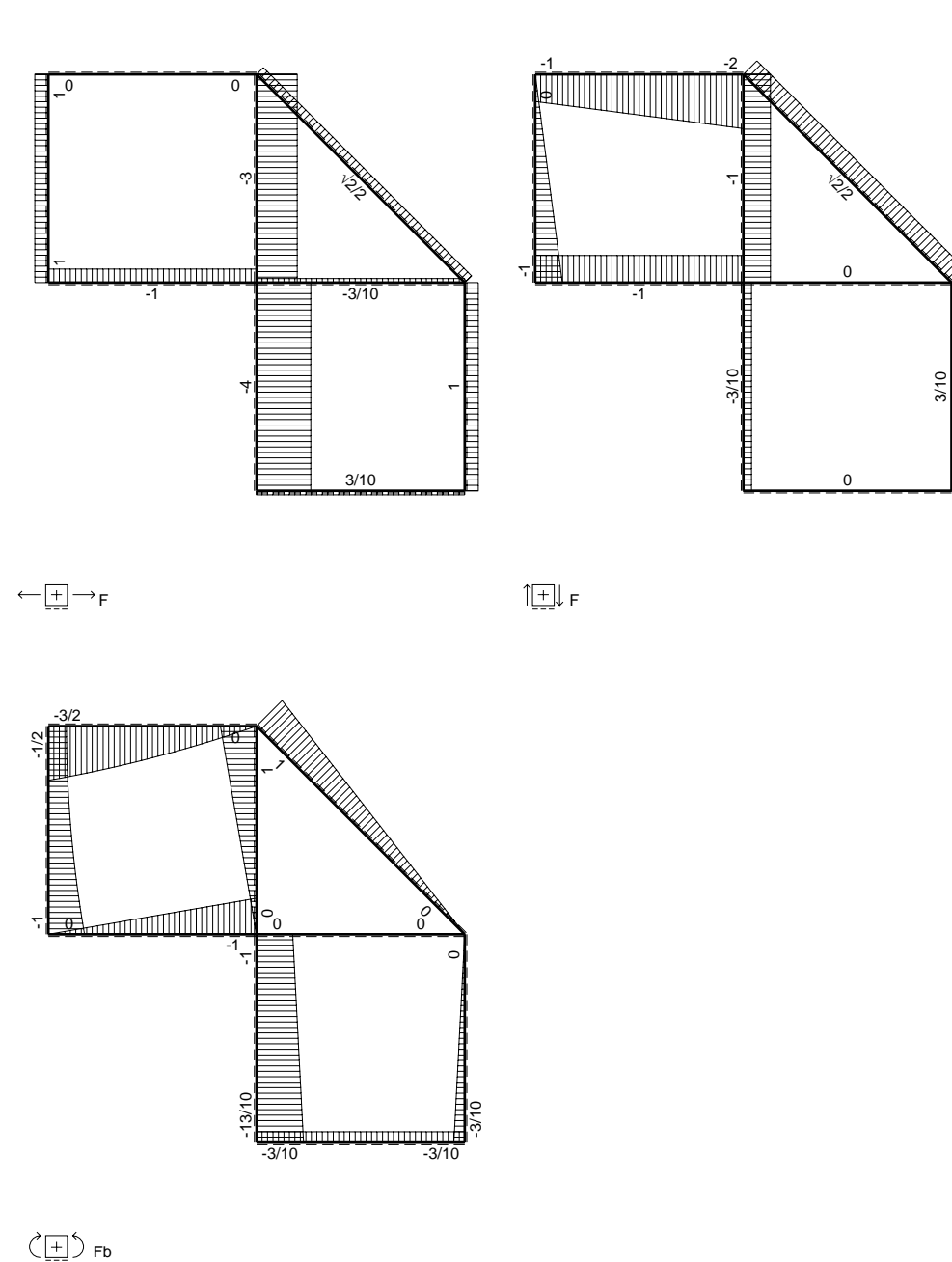
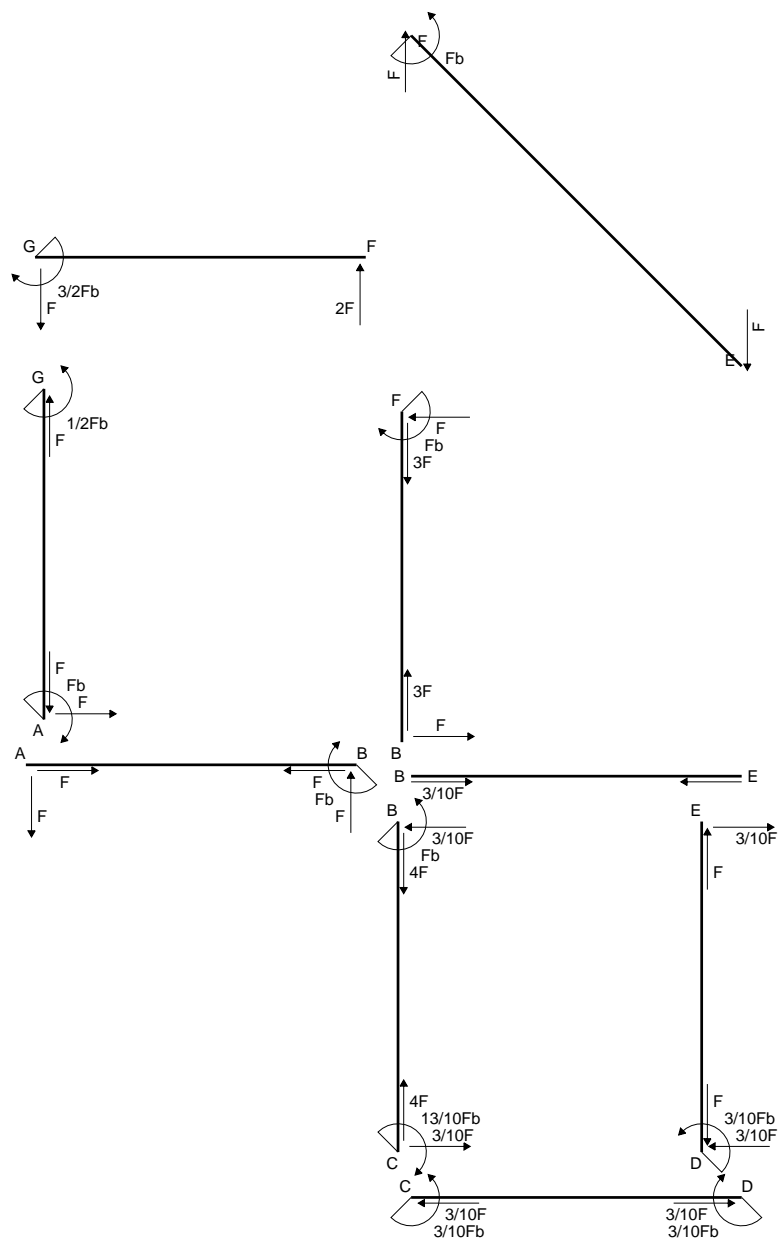

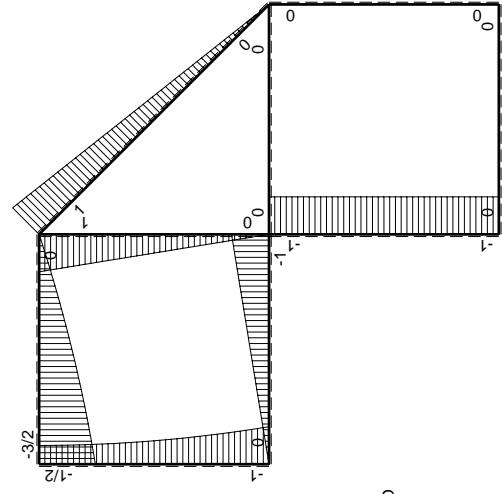
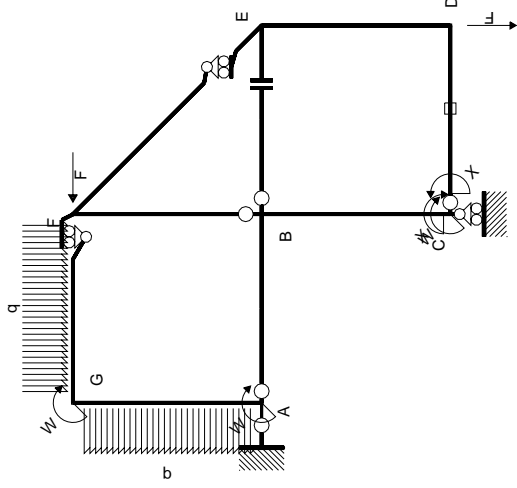

Schema di calcolo iperstatico

M_0 flessione da carichi assegnati

M_x flessione da iperstatica $X=1$

Quadro contribuiti PLV per iperstatica $X=W_{cd}$

\rightarrow	$M_x(x)$	$M_0(x)$	$M_x M_0$	$M_x M_x$	$\int M_x M_0 / EJ dx$	$\int X M_x M_x / EJ dx$
AB b	0	-Fx	0	0	0	0
BA b	0	Fb-Fx	0	0	0	0
BC b	-x/b	-Fb	Fx	x^2/b^2	$1/2 Fb^2/EJ$	$1/3 Xb^2/EJ$
CB b	$1-x/b$	Fb	Fb-Fx	$1-2x/b+x^2/b^2$		
CD b	-1	0	0	1	0	Xb/EJ
DC b	1	0	0	1	0	
DE b	$-1+x/b$	0	0	$1-2x/b+x^2/b^2$	0	$1/3 Xb^2/EJ$
ED b	x/b	0	0	x^2/b^2	0	0
EF $\sqrt{2}b$	0	$\sqrt{2}/2 Fx$	0	0	0	0
FG b	0	$-2Fx+1/2qx^2$	0	0	0	0
GF b	0	$3/2 Fb-Fx-1/2qx^2$	0	0	0	0
GA b	0	$-1/2 Fb-1/2qx^2$	0	0	0	0
AG b	0	$Fb-Fx+1/2qx^2$	0	0	0	0
FB b	0	Fb-Fx	0	0	0	0
BF b	0	-Fx	0	0	0	0
BE b	0	0	0	0	0	0
EB b	0	0	0	0	0	0
CD	elongazione asta $N_{1,cd} \epsilon_{cd} L_{cd}$				$-Fb^2/EJ$	
	totali				$-1/2 Fb^2/EJ$	$5/3 Xb^2/EJ$
	iperstatica $X=W_{cd}$				$3/10 Fb$	

Sviluppi di calcolo iperstatica

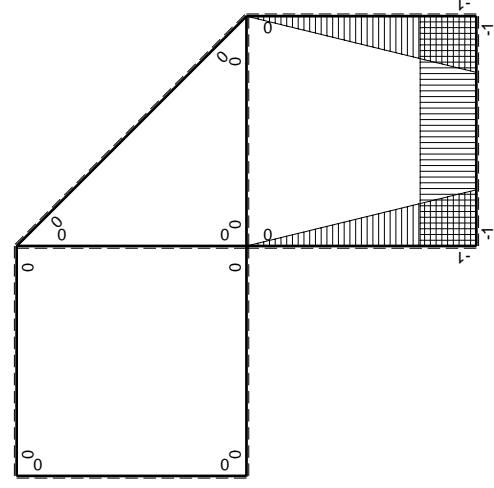

$$L_{BC}^{xx} = \int_0^b (x^2/b^2) 1/EJ dx = [1/3 x^3/b^2]_0^b 1/EJ$$

$$= (1/3 b) 1/EJ = 1/3 b/EJ$$

$$L_{CB}^{xx} = \int_0^b (1 - 2x/b + x^2/b^2) 1/EJ dx = [x - x^2/b + 1/3 x^3/b^2]_0^b 1/EJ$$

$$= (b - b + 1/3 b) 1/EJ = 1/3 b/EJ$$

$$L_{CD}^{xx} = \int_0^b (1) 1/EJ dx = [x]_0^b 1/EJ$$

$$= (b) 1/EJ = b/EJ$$

$$L_{DC}^{xx} = \int_0^b (1) 1/EJ dx = [x]_0^b 1/EJ$$

$$= (b) 1/EJ = b/EJ$$

$$L_{DE}^{xx} = \int_0^b (1 - 2x/b + x^2/b^2) 1/EJ dx = [x - x^2/b + 1/3 x^3/b^2]_0^b 1/EJ$$

$$= (b - b + 1/3 b) 1/EJ = 1/3 b/EJ$$

$$L_{ED}^{xx} = \int_0^b (x^2/b^2) 1/EJ dx = [1/3 x^3/b^2]_0^b 1/EJ$$

$$= (1/3 b) 1/EJ = 1/3 b/EJ$$

$$L_{BC}^{x_0} = \int_0^b (x/b) Fb 1/EJ dx = [1/2 x^2/b]_0^b Fb 1/EJ$$

$$= (1/2 b) Fb 1/EJ = 1/2 Fb^2/EJ$$

$$L_{CB}^{x_0} = \int_0^b (1 - x/b) Fb 1/EJ dx = [x - 1/2 x^2/b]_0^b Fb 1/EJ$$

$$= (b - 1/2 b) Fb 1/EJ = 1/2 Fb^2/EJ$$

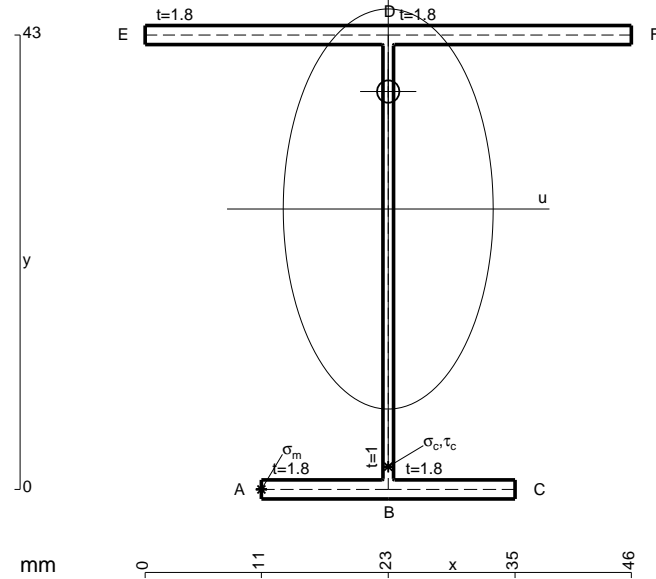

- A = 169. mm²
- J_u = 60580. mm⁴
- J_v = 16674. mm⁴
- J_i = 150.4 mm⁴
- y_o = 11.11 mm
- y_g = 26.54 mm
- T_y = -470. N
- M_x = -542850. Nmm
- x_m = 11. mm
- u_m = -12. mm
- v_m = -26.54 mm
- σ_m = -Mv/J_u = -237.8 N/mm²
- x_c = 23. mm
- v_c = -26.54 mm
- σ_c = -Mv/J_u = -237.8 N/mm²
- τ_c = TS'/tJ_u = 8.894 N/mm²
- τ_g = TS'/tJ_u = 8.894 N/mm²
- t_c = 470. mm
- σ_o = √σ²+3τ² = 238.3 N/mm²

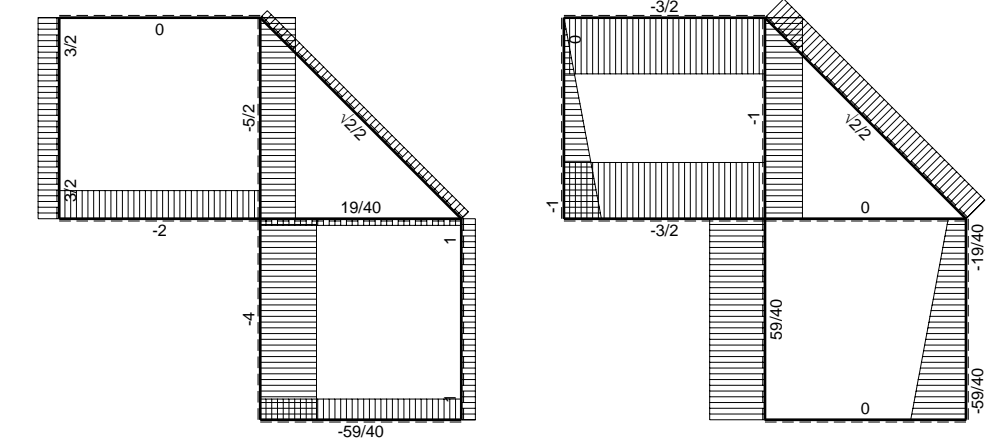
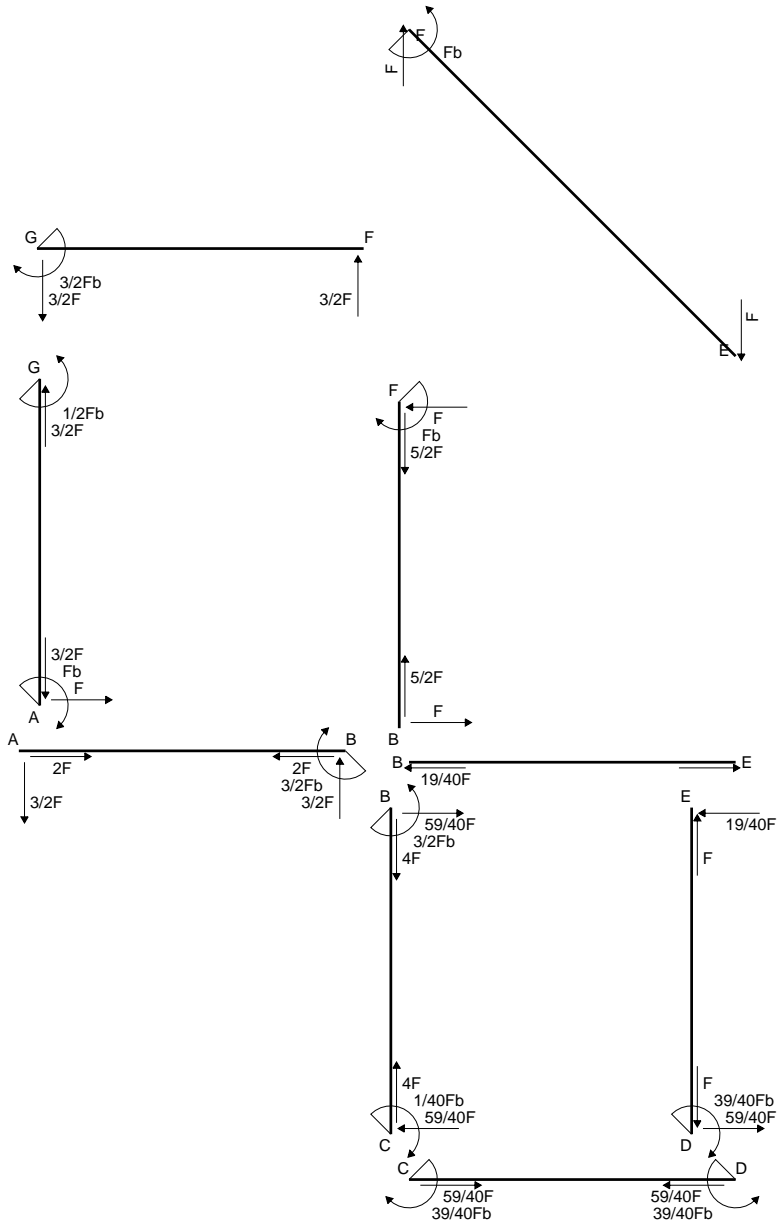

← ⊕ → F

↑ ⊕ ↓ F

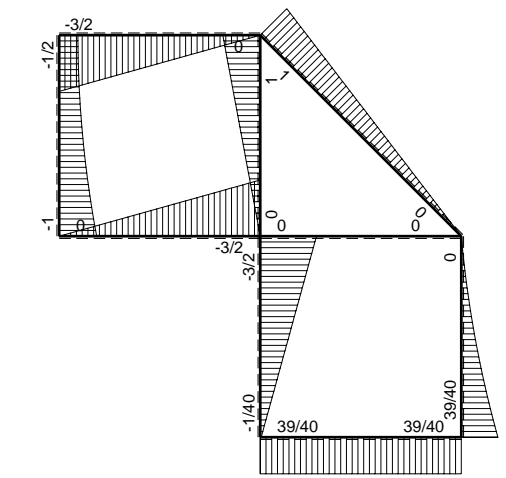

⊕ ⊕ F_b

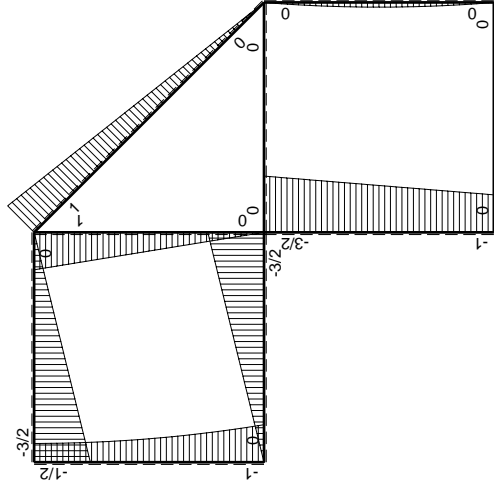
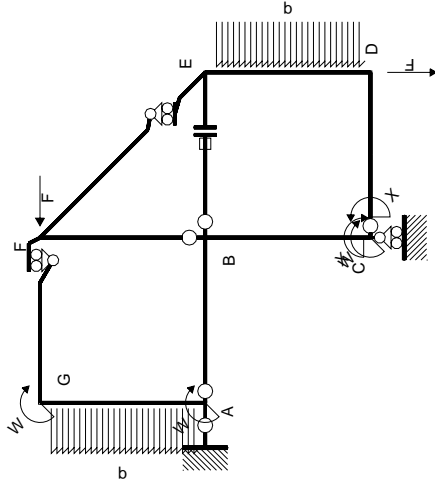

Schema di calcolo iperstatico

M_0 flessione da carichi assegnati

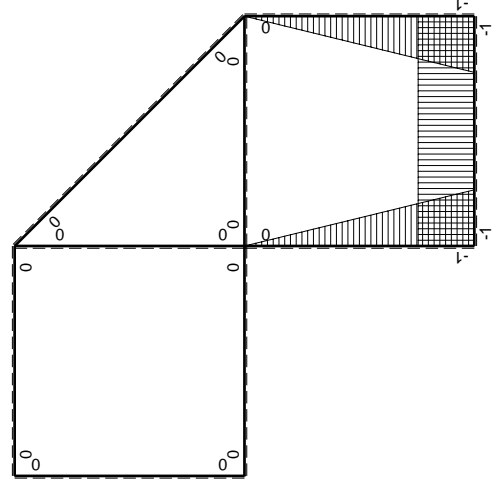

M_x flessione da iperstatica $X=1$

Quadro contribuiti PLV per iperstatica $X=W_{cd}$

\rightarrow	$M_x(x)$	$M_0(x)$	$M_x M_0$	$M_x M_x$	$\int M_x M_0 / EJ dx$	$\int X M_x M_x / EJ dx$
AB b	0	-3/2Fx	0	0	0	0
BA b	0	3/2Fb-3/2Fx	0	0	0	0
BC b	-x/b	-3/2Fb+1/2Fx	3/2Fx-1/2Fx ² /b	x ² /b ²	7/12Fb ² /EJ	1/3Xb/EJ
CB b	1-x/b	Fb+1/2Fx	Fb-1/2Fx-1/2Fx ² /b	1-2x/b+x ² /b ²	0	Xb/EJ
CD b	-1	0	0	1	0	0
DC b	1	0	0	1	0	0
DE b	-1+x/b	-1/2Fx+1/2qx ²	1/2Fx-Fx ² /b+1/2qx ³ /b	1-2x/b+x ² /b ²	1/24Fb ² /EJ	1/3Xb/EJ
ED b	x/b	1/2Fx-1/2qx ²	1/2Fx ² /b-1/2qx ³ /b	x ² /b ²	0	0
EF $\sqrt{2}b$	0	$\sqrt{2}2Fx$	0	0	0	0
FG b	0	-3/2Fx	0	0	0	0
GF b	0	3/2Fb-3/2Fx	0	0	0	0
GA b	0	-1/2Fb-1/2qx ²	0	0	0	0
AG b	0	Fb-Fx+1/2qx ²	0	0	0	0
FB b	0	Fb-Fx	0	0	0	0
BF b	0	-Fx	0	0	0	0
BE b	0	0	0	0	0	0
EB b	0	0	0	0	0	0
BE	elongazione asta $N_{1, BE} \epsilon_{BE} L_{BE}$				Fb ² /EJ	
	totali				13/8Fb ² /EJ	5/3Xb/EJ
	iperstatica $X=W_{cd}$				-39/40Fb	

Sviluppi di calcolo iperstatica

$$L_{BC}^{xx} = \int_0^b (x^2/b^2) 1/EJ dx = [1/3 x^3/b^2]_0^b 1/EJ$$

$$= (1/3 b) 1/EJ = 1/3 b/EJ$$

$$L_{CB}^{xx} = \int_0^b (1 - 2x/b + x^2/b^2) 1/EJ dx = [x - x^2/b + 1/3 x^3/b^2]_0^b 1/EJ$$

$$= (b - b + 1/3 b) 1/EJ = 1/3 b/EJ$$

$$L_{CD}^{xx} = \int_0^b (1) 1/EJ dx = [x]_0^b 1/EJ$$

$$= (b) 1/EJ = b/EJ$$

$$L_{DC}^{xx} = \int_0^b (1) 1/EJ dx = [x]_0^b 1/EJ$$

$$= (b) 1/EJ = b/EJ$$

$$L_{DE}^{xx} = \int_0^b (1 - 2x/b + x^2/b^2) 1/EJ dx = [x - x^2/b + 1/3 x^3/b^2]_0^b 1/EJ$$

$$= (b - b + 1/3 b) 1/EJ = 1/3 b/EJ$$

$$L_{ED}^{xx} = \int_0^b (x^2/b^2) 1/EJ dx = [1/3 x^3/b^2]_0^b 1/EJ$$

$$= (1/3 b) 1/EJ = 1/3 b/EJ$$

$$L_{BC}^{xo} = \int_0^b (3/2 x/b - 1/2 x^2/b^2) Fb 1/EJ dx = [3/4 x^2/b - 1/6 x^3/b^2]_0^b Fb 1/EJ$$

$$= (3/4 b - 1/6 b) Fb 1/EJ = 7/12 Fb^2/EJ$$

$$L_{CB}^{xo} = \int_0^b (1 - 1/2 x/b - 1/2 x^2/b^2) Fb 1/EJ dx = [x - 1/4 x^2/b - 1/6 x^3/b^2]_0^b Fb 1/EJ$$

$$= (b - 1/4 b - 1/6 b) Fb 1/EJ = 7/12 Fb^2/EJ$$

$$L_{DE}^{xo} = \int_0^b (1/2 x/b - x^2/b^2 + 1/2 x^3/b^3) Fb 1/EJ dx = [1/4 x^2/b - 1/3 x^3/b^2 + 1/8 x^4/b^3]_0^b Fb 1/EJ$$

$$= (1/4 b - 1/3 b + 1/8 b) Fb 1/EJ = 1/24 Fb^2/EJ$$

$$L_{ED}^{xo} = \int_0^b (1/2 x^2/b^2 - 1/2 x^3/b^3) Fb 1/EJ dx = [1/6 x^3/b^2 - 1/8 x^4/b^3]_0^b Fb 1/EJ$$

$$= (1/6 b - 1/8 b) Fb 1/EJ = 1/24 Fb^2/EJ$$

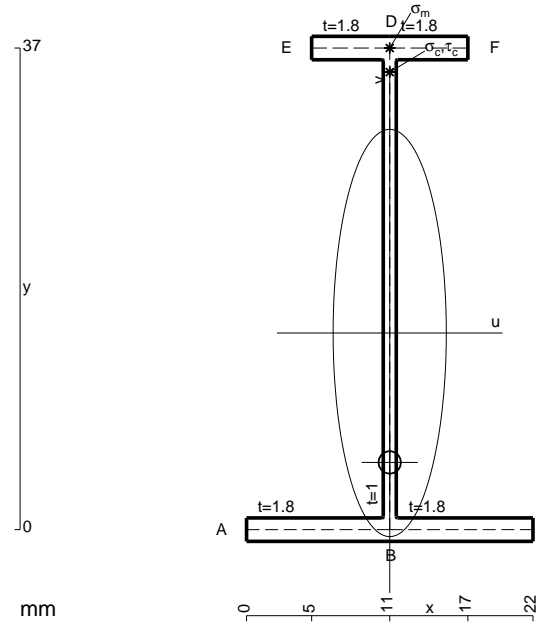

- A = 98.2 mm²
- J_u = 24038. mm⁴
- J_v = 1856. mm⁴
- J_i = 78.43 mm⁴
- y_o = -9.943 mm
- y_g = 15.11 mm
- T_y = -615. N
- M_x = -215250. Nmm
- x_m = 11. mm
- y_m = 37. mm
- v_m = 21.89 mm
- σ_m = -Mv/J_u = 196. N/mm²
- y_c = 2. mm
- u_c = -11. mm
- v_c = -13.11 mm
- σ_c = -Mv/J_u = 196. N/mm²
- τ_c = TS_i/tJ_u = 12.1 N/mm²
- τ_g = TS_i/tJ_u = 12.1 N/mm²
- t_c = 410. mm
- σ_o = √σ²+3τ² = 197.1 N/mm²

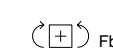
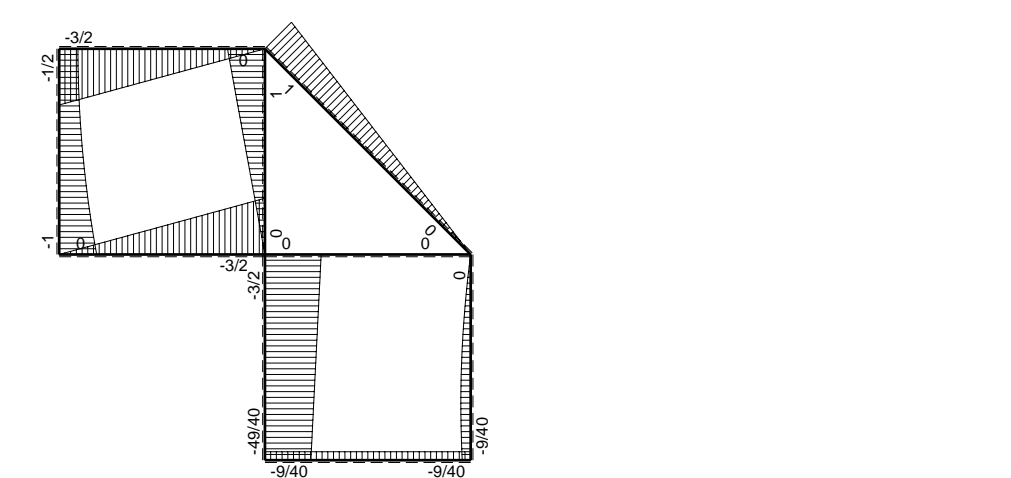
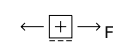
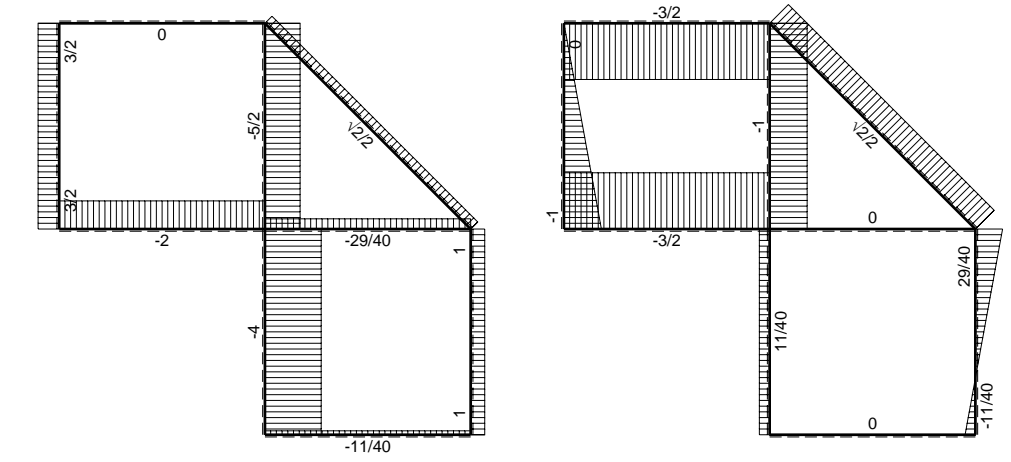
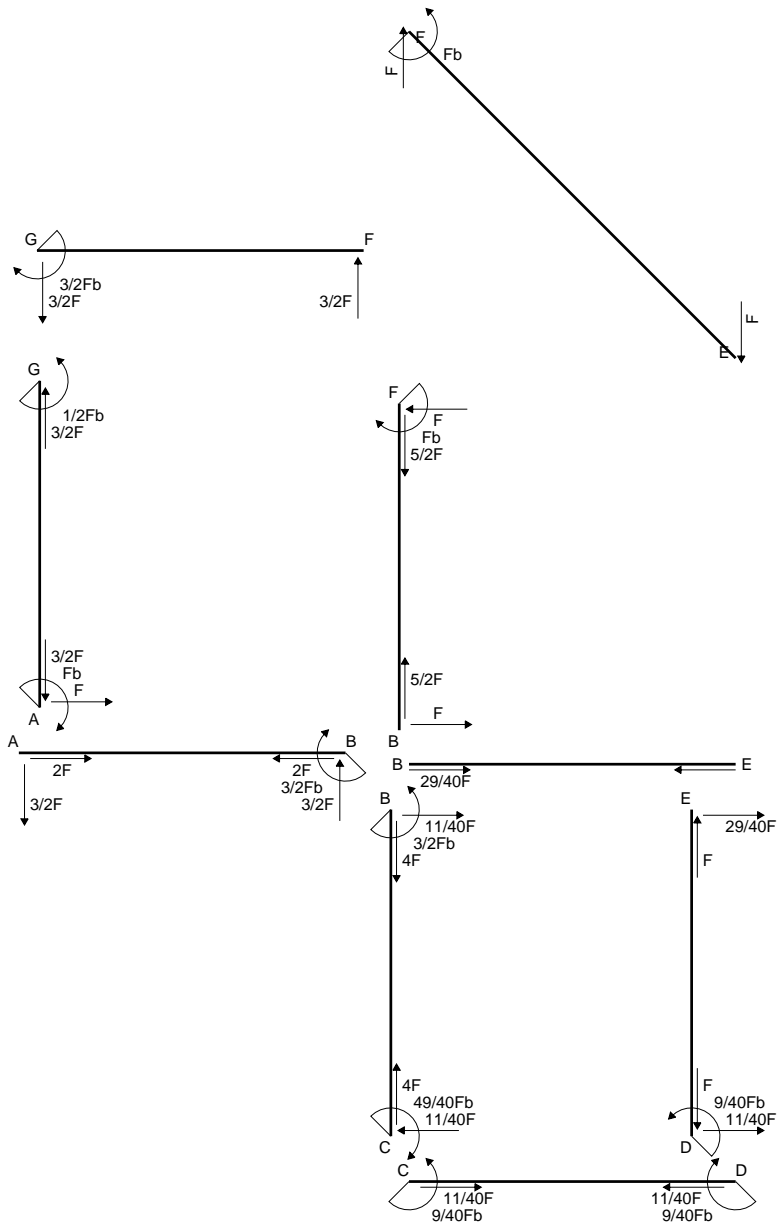

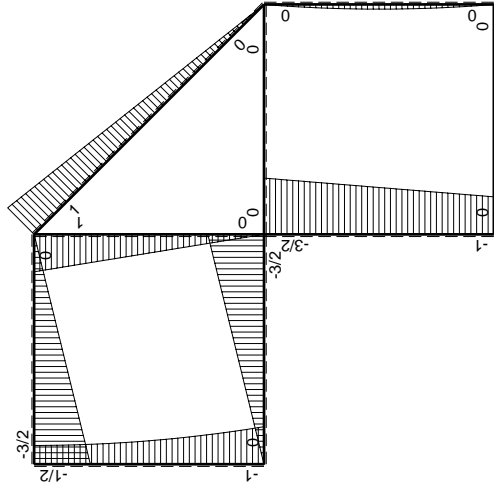
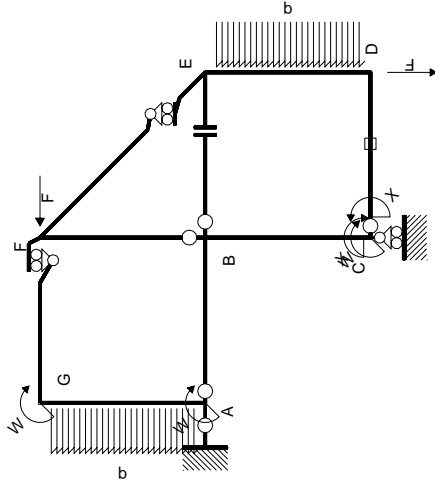

Schema di calcolo iperstatico

M_0 flessione da carichi assegnati

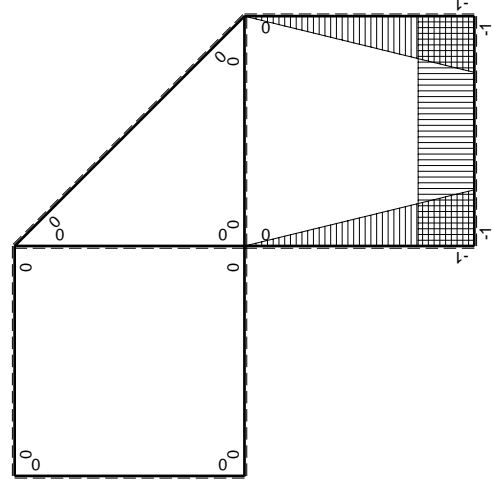

M_x flessione da iperstatica X=1

Quadro contribuiti PLV per iperstatica X=W_{cd}

→	$M_x(x)$	$M_0(x)$	$M_x M_0$	$M_x M_x$	$\int M_x M_0 / EJ dx$	$\int X M_x M_x / EJ dx$
AB b	0	-3/2Fx	0	0	0	0
BA b	0	3/2Fb-3/2Fx	0	0	0	0
BC b	-x/b	-3/2Fb+1/2Fx	3/2Fx-1/2Fx ² /b	x ² /b ²	7/12Fb ² /EJ	1/3Xb/EJ
CB b	1-x/b	Fb+1/2Fx	Fb-1/2Fx-1/2Fx ² /b	1-2x/b+x ² /b ²	0	Xb/EJ
CD b	-1	0	0	1	0	0
DC b	1	0	0	1	0	0
DE b	-1+x/b	-1/2Fx+1/2qx ²	1/2Fx-Fx ² /b+1/2qx ³ /b	1-2x/b+x ² /b ²	1/24Fb ² /EJ	1/3Xb/EJ
ED b	x/b	1/2Fx-1/2qx ²	1/2Fx ² /b-1/2qx ³ /b	x ² /b ²	0	0
EF √2b	0	√2/2Fx	0	0	0	0
FG b	0	-3/2Fx	0	0	0	0
GF b	0	3/2Fb-3/2Fx	0	0	0	0
GA b	0	-1/2Fb-1/2qx ²	0	0	0	0
AG b	0	Fb-Fx+1/2qx ²	0	0	0	0
FB b	0	Fb-Fx	0	0	0	0
BF b	0	-Fx	0	0	0	0
BE b	0	0	0	0	0	0
EB b	0	0	0	0	0	0
CD	elongazione asta $N_{1,cd} \epsilon_{cd} L_{cd}$				-Fb ² /EJ	
	totali				-3/8Fb ² /EJ	5/3Xb/EJ
	iperstatica X=W _{cd}				9/40Fb	

Sviluppi di calcolo iperstatica

$$L_{BC}^{xx} = \int_0^b (x^2/b^2) 1/EJ dx = [1/3 x^3/b^2]_0^b 1/EJ$$

$$= (1/3 b) 1/EJ = 1/3 b/EJ$$

$$L_{CB}^{xx} = \int_0^b (1 - 2x/b + x^2/b^2) 1/EJ dx = [x - x^2/b + 1/3 x^3/b^2]_0^b 1/EJ$$

$$= (b - b + 1/3 b) 1/EJ = 1/3 b/EJ$$

$$L_{CD}^{xx} = \int_0^b (1) 1/EJ dx = [x]_0^b 1/EJ$$

$$= (b) 1/EJ = b/EJ$$

$$L_{DC}^{xx} = \int_0^b (1) 1/EJ dx = [x]_0^b 1/EJ$$

$$= (b) 1/EJ = b/EJ$$

$$L_{DE}^{xx} = \int_0^b (1 - 2x/b + x^2/b^2) 1/EJ dx = [x - x^2/b + 1/3 x^3/b^2]_0^b 1/EJ$$

$$= (b - b + 1/3 b) 1/EJ = 1/3 b/EJ$$

$$L_{ED}^{xx} = \int_0^b (x^2/b^2) 1/EJ dx = [1/3 x^3/b^2]_0^b 1/EJ$$

$$= (1/3 b) 1/EJ = 1/3 b/EJ$$

$$L_{BC}^{xo} = \int_0^b (3/2 x/b - 1/2 x^2/b^2) Fb 1/EJ dx = [3/4 x^2/b - 1/6 x^3/b^2]_0^b Fb 1/EJ$$

$$= (3/4 b - 1/6 b) Fb 1/EJ = 7/12 Fb^2/EJ$$

$$L_{CB}^{xo} = \int_0^b (1 - 1/2 x/b - 1/2 x^2/b^2) Fb 1/EJ dx = [x - 1/4 x^2/b - 1/6 x^3/b^2]_0^b Fb 1/EJ$$

$$= (b - 1/4 b - 1/6 b) Fb 1/EJ = 7/12 Fb^2/EJ$$

$$L_{DE}^{xo} = \int_0^b (1/2 x/b - x^2/b^2 + 1/2 x^3/b^3) Fb 1/EJ dx = [1/4 x^2/b - 1/3 x^3/b^2 + 1/8 x^4/b^3]_0^b Fb 1/EJ$$

$$= (1/4 b - 1/3 b + 1/8 b) Fb 1/EJ = 1/24 Fb^2/EJ$$

$$L_{ED}^{xo} = \int_0^b (1/2 x^2/b^2 - 1/2 x^3/b^3) Fb 1/EJ dx = [1/6 x^3/b^2 - 1/8 x^4/b^3]_0^b Fb 1/EJ$$

$$= (1/6 b - 1/8 b) Fb 1/EJ = 1/24 Fb^2/EJ$$

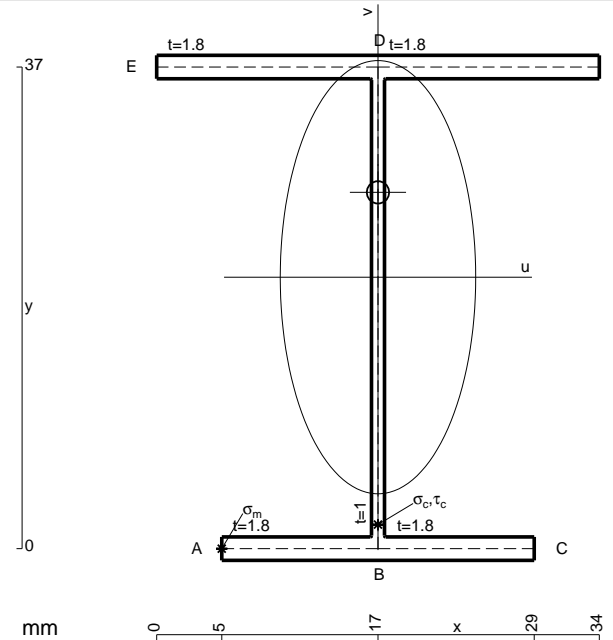

- A = 141.4 mm²
- J_u = 39168. mm⁴
- J_v = 7969. mm⁴
- J_I = 125.1 mm⁴
- y_o = 6.518 mm
- y_g = 20.85 mm
- N = -1320. N
- T_y = -990. N
- M_x = -376200. Nmm
- x_m = 5. mm
- u_m = -12. mm
- v_m = -20.85 mm
- σ_m = N/A-Mv/J_u = -209.6 N/mm²
- x_c = 17. mm
- v_c = -20.85 mm
- σ_c = N/A-Mv/J_u = -209.6 N/mm²
- τ_c = TS¹/tJ_u = 22.77 N/mm²
- τ_g = TS¹/tJ_u = 22.77 N/mm²
- t_c = 660. mm
- σ_o = √σ²+3τ² = 213.3 N/mm²

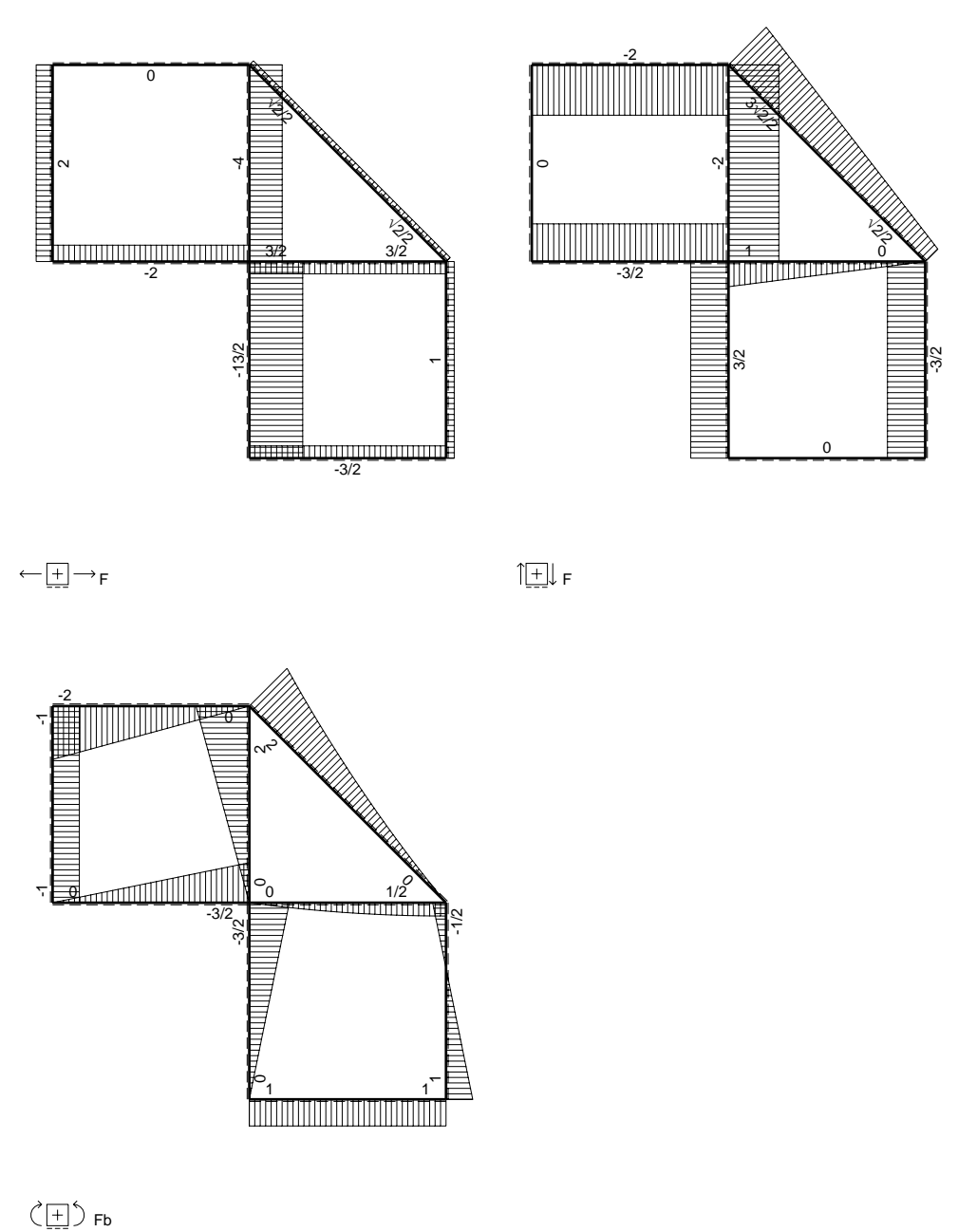
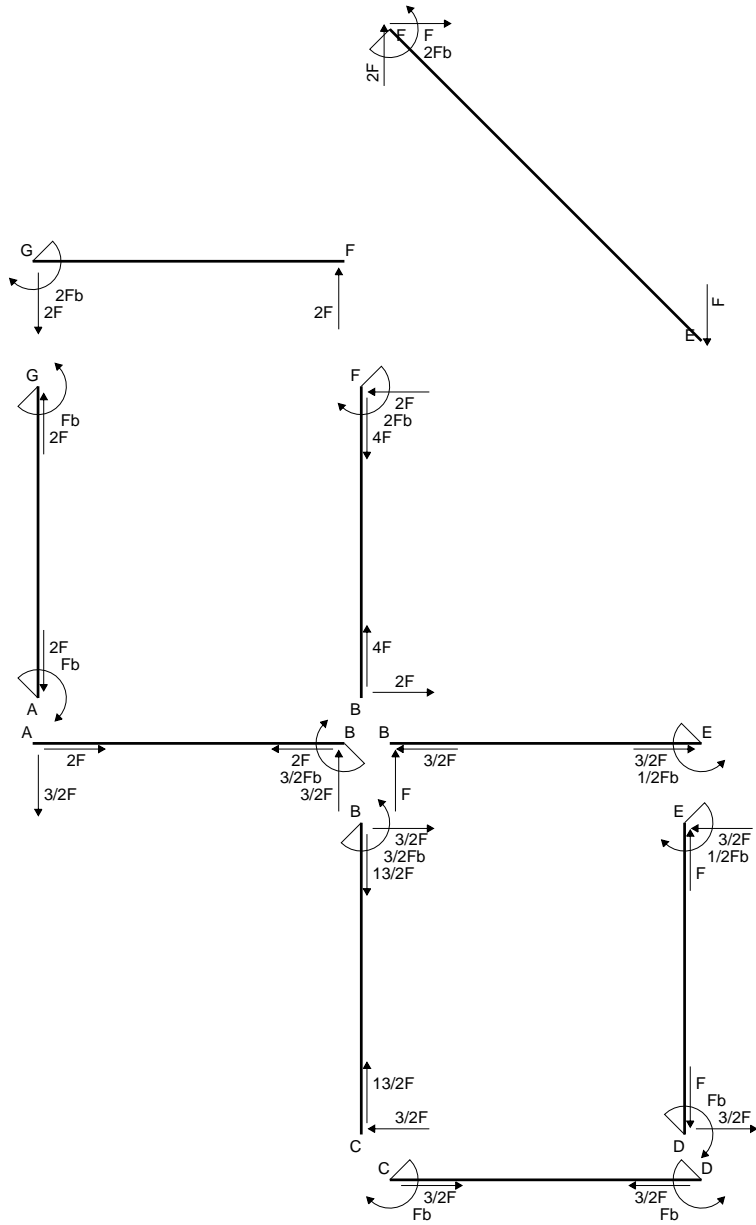

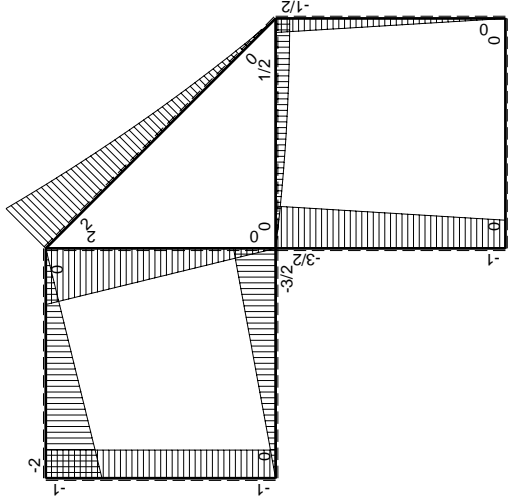
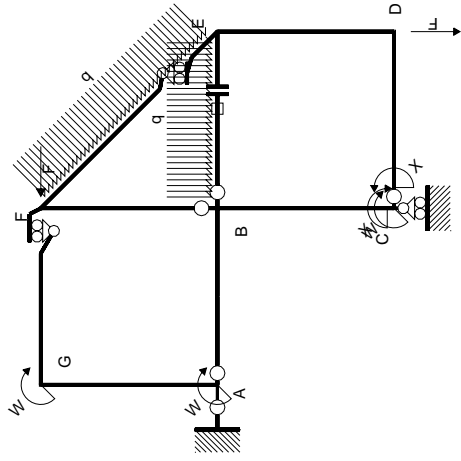

Schema di calcolo iperstatico

M_0 flessione da carichi assegnati

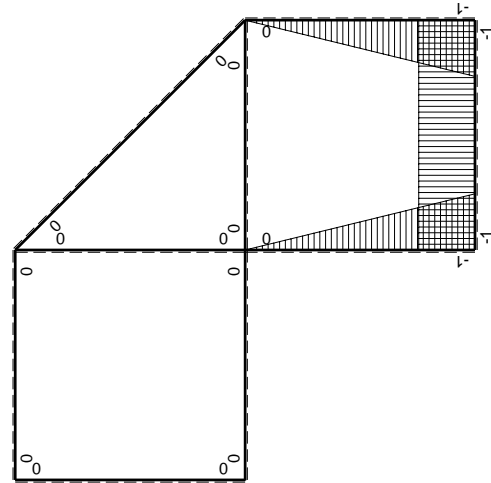

M_x flessione da iperstatica $X=1$

Quadro contribuiti PLV per iperstatica $X=W_{cd}$

\rightarrow	$M_x(x)$	$M_0(x)$	$M_x M_0$	$M_x M_x$	$\int M_x M_0 / E J dx$	$\int X M_x M_x / E J dx$
AB b	0	-3/2Fx	0	0	0	0
BA b	0	3/2Fb-3/2Fx	0	0	0	0
BC b	-x/b	-3/2Fb+1/2Fx	3/2Fx-1/2Fx ² /b	x ² /b ²	7/12Fb ² /EJ	1/3Xb/EJ
CB b	1-x/b	Fb+1/2Fx	Fb-1/2Fx-1/2Fx ² /b	1-2x/b+x ² /b ²	0	Xb/EJ
CD b	-1	0	0	1	0	0
DC b	1	0	0	1	0	0
DE b	-1+x/b	-1/2Fx	1/2Fx-1/2Fx ² /b	1-2x/b+x ² /b ²	1/12Fb ² /EJ	1/3Xb/EJ
ED b	x/b	1/2Fb-1/2Fx	1/2Fx-1/2Fx ² /b	x ² /b ²	0	0
EF $\sqrt{2}b$	0	$\sqrt{2}/2Fx+1/2qx^2$	0	0	0	0
FG b	0	-2Fx	0	0	0	0
GF b	0	2Fb-2Fx	0	0	0	0
GA b	0	-Fb	0	0	0	0
AG b	0	Fb	0	0	0	0
FB b	0	2Fb-2Fx	0	0	0	0
BF b	0	-2Fx	0	0	0	0
BE b	0	Fx-1/2qx ²	0	0	0	0
EB b	0	-1/2Fb+1/2qx ²	0	0	0	0
BE	elongazione asta $N_{1, BE} \epsilon_{BE} L_{BE}$				Fb ² /EJ	
	totali				5/3Fb ² /EJ	5/3Xb/EJ
	iperstatica $X=W_{cd}$				-Fb	

Sviluppi di calcolo iperstatica

$$L_{BC}^{xx} = \int_0^b (x^2/b^2) 1/EJ dx = [1/3 x^3/b^2]_0^b 1/EJ$$

$$= (1/3 b) 1/EJ = 1/3 b/EJ$$

$$L_{CB}^{xx} = \int_0^b (1 - 2x/b + x^2/b^2) 1/EJ dx = [x - x^2/b + 1/3 x^3/b^2]_0^b 1/EJ$$

$$= (b - b + 1/3 b) 1/EJ = 1/3 b/EJ$$

$$L_{CD}^{xx} = \int_0^b (1) 1/EJ dx = [x]_0^b 1/EJ$$

$$= (b) 1/EJ = b/EJ$$

$$L_{DC}^{xx} = \int_0^b (1) 1/EJ dx = [x]_0^b 1/EJ$$

$$= (b) 1/EJ = b/EJ$$

$$L_{DE}^{xx} = \int_0^b (1 - 2x/b + x^2/b^2) 1/EJ dx = [x - x^2/b + 1/3 x^3/b^2]_0^b 1/EJ$$

$$= (b - b + 1/3 b) 1/EJ = 1/3 b/EJ$$

$$L_{ED}^{xx} = \int_0^b (x^2/b^2) 1/EJ dx = [1/3 x^3/b^2]_0^b 1/EJ$$

$$= (1/3 b) 1/EJ = 1/3 b/EJ$$

$$L_{BC}^{x_0} = \int_0^b (3/2 x/b - 1/2 x^2/b^2) Fb 1/EJ dx = [3/4 x^2/b - 1/6 x^3/b^2]_0^b Fb 1/EJ$$

$$= (3/4 b - 1/6 b) Fb 1/EJ = 7/12 Fb^2/EJ$$

$$L_{CB}^{x_0} = \int_0^b (1 - 1/2 x/b - 1/2 x^2/b^2) Fb 1/EJ dx = [x - 1/4 x^2/b - 1/6 x^3/b^2]_0^b Fb 1/EJ$$

$$= (b - 1/4 b - 1/6 b) Fb 1/EJ = 7/12 Fb^2/EJ$$

$$L_{DE}^{x_0} = \int_0^b (1/2 x/b - 1/2 x^2/b^2) Fb 1/EJ dx = [1/4 x^2/b - 1/6 x^3/b^2]_0^b Fb 1/EJ$$

$$= (1/4 b - 1/6 b) Fb 1/EJ = 1/12 Fb^2/EJ$$

$$L_{ED}^{x_0} = \int_0^b (1/2 x/b - 1/2 x^2/b^2) Fb 1/EJ dx = [1/4 x^2/b - 1/6 x^3/b^2]_0^b Fb 1/EJ$$

$$= (1/4 b - 1/6 b) Fb 1/EJ = 1/12 Fb^2/EJ$$

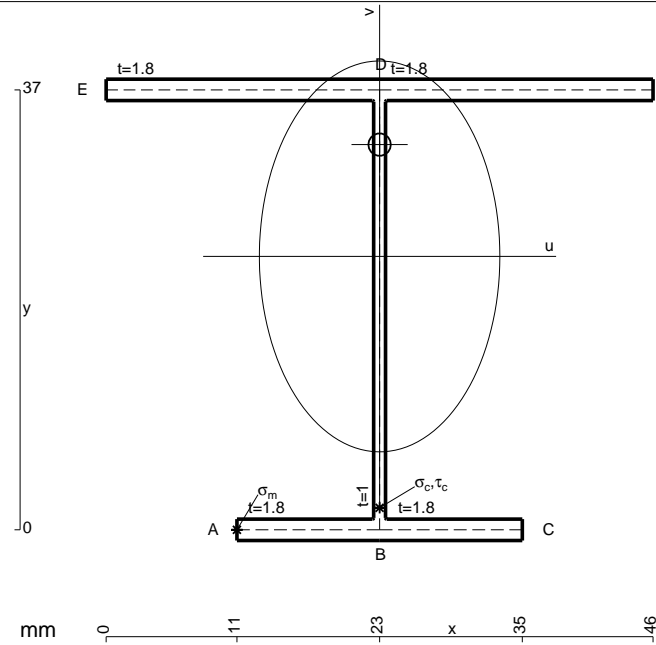

- A = 163. mm²
- J_u = 44052. mm⁴
- J_v = 16674. mm⁴
- J_t = 148.4 mm⁴
- y₀ = 9.404 mm
- y_g = 22.99 mm
- N = 346.5 N
- T_y = 1039. N
- M_x = 411600. Nmm
- x_m = 11. mm
- u_m = -12. mm
- v_m = -22.99 mm
- σ_m = N/A - Mv/J_u = 217. N/mm²
- x_c = 23. mm
- v_c = -22.99 mm
- σ_c = N/A - Mv/J_u = 217. N/mm²
- τ_c = TS_v/tJ_u = 23.44 N/mm²
- τ_g = TS_v/tJ_u = 23.44 N/mm²
- t_c = 490. mm
- σ₀ = √σ² + 3τ² = 220.7 N/mm²

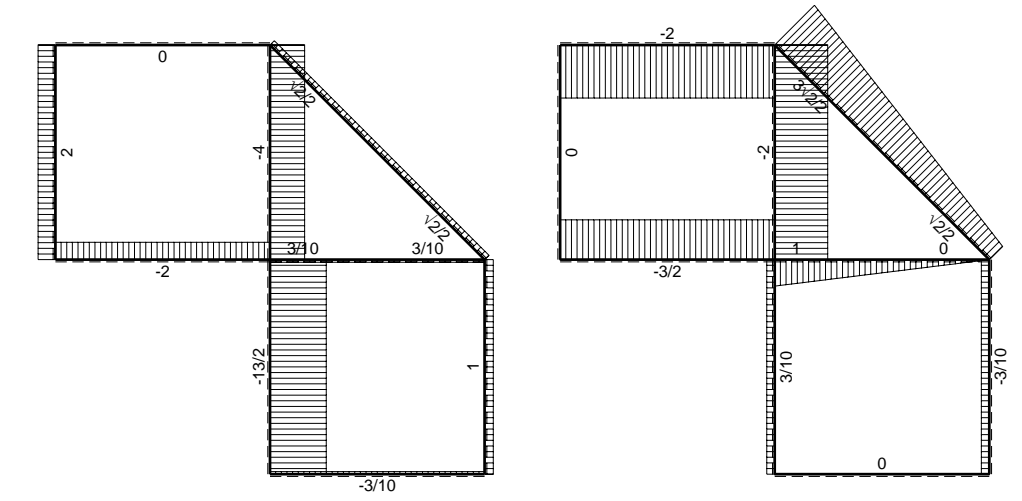
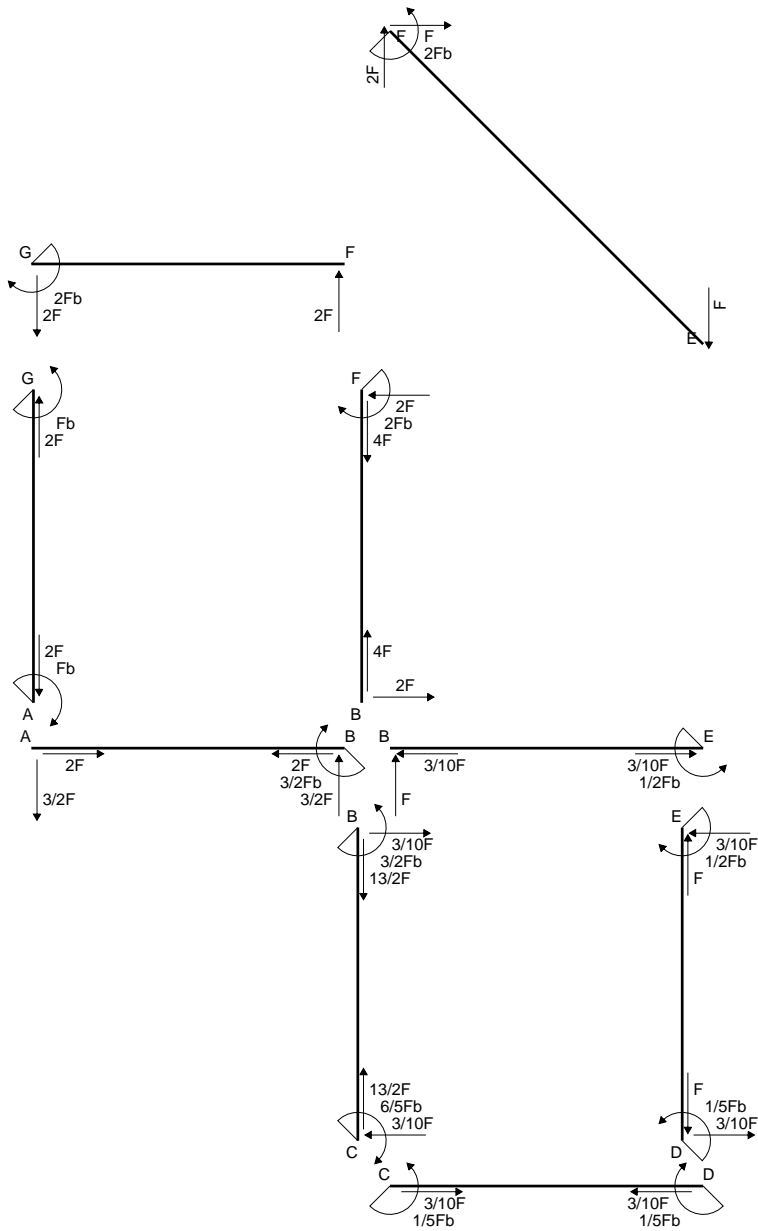

← (+) → F

↑ (+) ↓ F

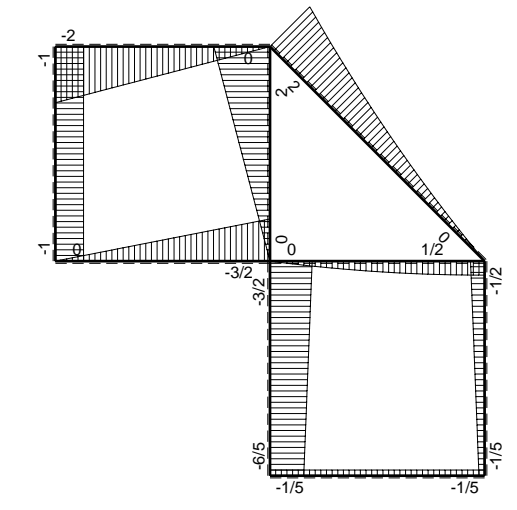

⊙ (+) ⊙ F_b

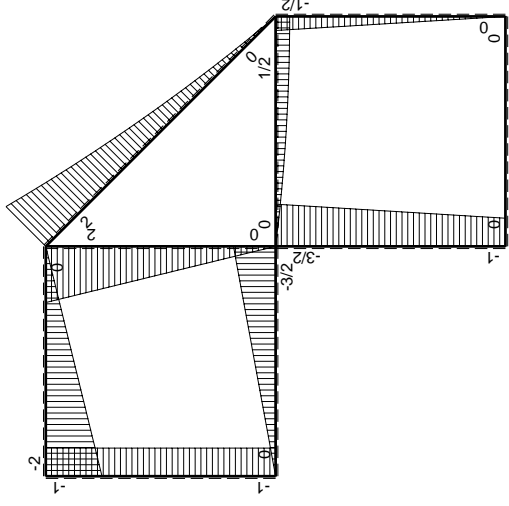
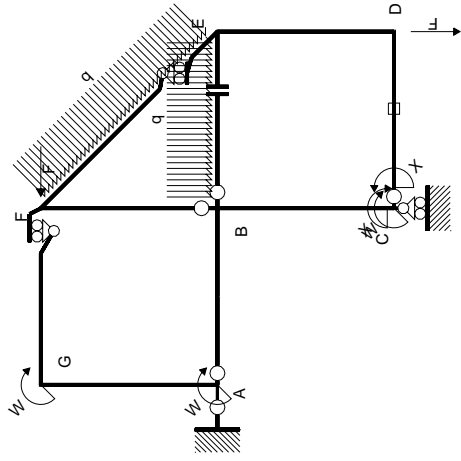

Schema di calcolo iperstatico

M_0 flessione da carichi assegnati

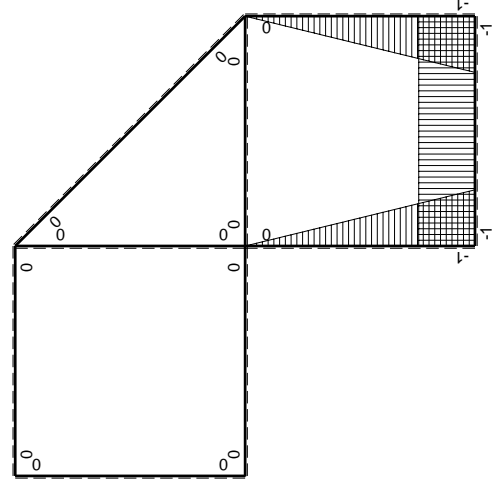

M_x flessione da iperstatica $X=1$

Quadro contribuiti PLV per iperstatica $X=W_{cd}$

\rightarrow	$M_x(x)$	$M_0(x)$	$M_x M_0$	$M_x M_x$	$\int M_x M_0 / E J dx$	$\int X M_x M_x / E J dx$
AB b	0	-3/2Fx	0	0	0	0
BA b	0	3/2Fb-3/2Fx	0	0	0	0
BC b	-x/b	-3/2Fb+1/2Fx	3/2Fx-1/2Fx ² /b	x ² /b ²	7/12Fb ² /EJ	1/3Xb/EJ
CB b	1-x/b	Fb+1/2Fx	Fb-1/2Fx-1/2Fx ² /b	1-2x/b+x ² /b ²	0	Xb/EJ
CD b	-1	0	0	1	0	0
DC b	1	0	0	1	0	0
DE b	-1+x/b	-1/2Fx	1/2Fx-1/2Fx ² /b	1-2x/b+x ² /b ²	1/12Fb ² /EJ	1/3Xb/EJ
ED b	x/b	1/2Fb-1/2Fx	1/2Fx-1/2Fx ² /b	x ² /b ²	0	0
EF $\sqrt{2}b$	0	$\sqrt{2}/2Fx+1/2qx^2$	0	0	0	0
FG b	0	-2Fx	0	0	0	0
GF b	0	2Fb-2Fx	0	0	0	0
GA b	0	-Fb	0	0	0	0
AG b	0	Fb	0	0	0	0
FB b	0	2Fb-2Fx	0	0	0	0
BF b	0	-2Fx	0	0	0	0
BE b	0	Fx-1/2qx ²	0	0	0	0
EB b	0	-1/2Fb+1/2qx ²	0	0	0	0
CD	elongazione asta $N_{1,cd} \epsilon_{cd} L_{cd}$				-Fb ² /EJ	
	totali				-1/3Fb ² /EJ	5/3Xb/EJ
	iperstatica $X=W_{cd}$				1/5Fb	

Sviluppi di calcolo iperstatica

$$L_{BC}^{xx} = \int_0^b (x^2/b^2) 1/EJ dx = [1/3 x^3/b^2]_0^b 1/EJ$$

$$= (1/3 b) 1/EJ = 1/3 b/EJ$$

$$L_{CB}^{xx} = \int_0^b (1 - 2x/b + x^2/b^2) 1/EJ dx = [x - x^2/b + 1/3 x^3/b^2]_0^b 1/EJ$$

$$= (b - b + 1/3 b) 1/EJ = 1/3 b/EJ$$

$$L_{CD}^{xx} = \int_0^b (1) 1/EJ dx = [x]_0^b 1/EJ$$

$$= (b) 1/EJ = b/EJ$$

$$L_{DC}^{xx} = \int_0^b (1) 1/EJ dx = [x]_0^b 1/EJ$$

$$= (b) 1/EJ = b/EJ$$

$$L_{DE}^{xx} = \int_0^b (1 - 2x/b + x^2/b^2) 1/EJ dx = [x - x^2/b + 1/3 x^3/b^2]_0^b 1/EJ$$

$$= (b - b + 1/3 b) 1/EJ = 1/3 b/EJ$$

$$L_{ED}^{xx} = \int_0^b (x^2/b^2) 1/EJ dx = [1/3 x^3/b^2]_0^b 1/EJ$$

$$= (1/3 b) 1/EJ = 1/3 b/EJ$$

$$L_{BC}^{x_0} = \int_0^b (3/2 x/b - 1/2 x^2/b^2) Fb 1/EJ dx = [3/4 x^2/b - 1/6 x^3/b^2]_0^b Fb 1/EJ$$

$$= (3/4 b - 1/6 b) Fb 1/EJ = 7/12 Fb^2/EJ$$

$$L_{CB}^{x_0} = \int_0^b (1 - 1/2 x/b - 1/2 x^2/b^2) Fb 1/EJ dx = [x - 1/4 x^2/b - 1/6 x^3/b^2]_0^b Fb 1/EJ$$

$$= (b - 1/4 b - 1/6 b) Fb 1/EJ = 7/12 Fb^2/EJ$$

$$L_{DE}^{x_0} = \int_0^b (1/2 x/b - 1/2 x^2/b^2) Fb 1/EJ dx = [1/4 x^2/b - 1/6 x^3/b^2]_0^b Fb 1/EJ$$

$$= (1/4 b - 1/6 b) Fb 1/EJ = 1/12 Fb^2/EJ$$

$$L_{ED}^{x_0} = \int_0^b (1/2 x/b - 1/2 x^2/b^2) Fb 1/EJ dx = [1/4 x^2/b - 1/6 x^3/b^2]_0^b Fb 1/EJ$$

$$= (1/4 b - 1/6 b) Fb 1/EJ = 1/12 Fb^2/EJ$$

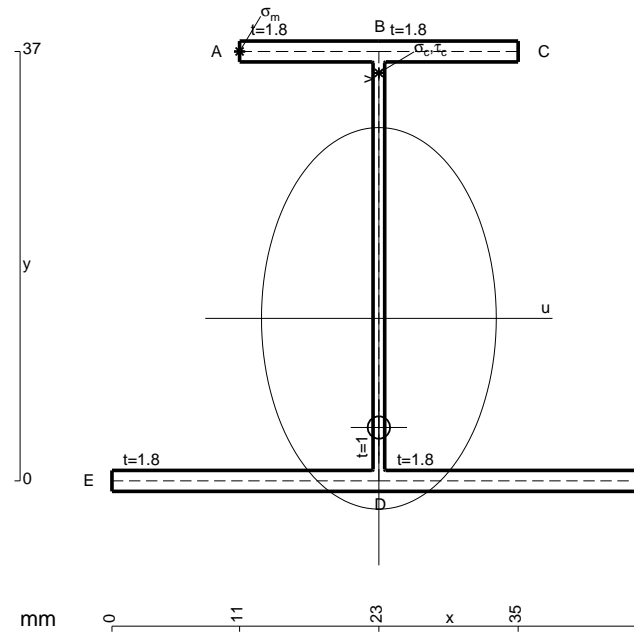

- A = 163. mm²
- J_u = 44052. mm⁴
- J_v = 16674. mm⁴
- J_i = 148.4 mm⁴
- y_o = -9.404 mm
- y_g = 14.01 mm
- N = -1840. N
- T_y = -920. N
- M_x = 414000. Nmm
- x_m = 11. mm
- y_m = 37. mm
- u_m = -12. mm
- v_m = 22.99 mm
- σ_m = N/A-Mv/J_u = -227.4 N/mm²
- x_c = 23. mm
- y_c = 37. mm
- v_c = 22.99 mm
- σ_c = N/A-Mv/J_u = -227.4 N/mm²
- τ_c = TS/tJ_u = 20.75 N/mm²
- τ_g = TS/tJ_u = 20.75 N/mm²
- t_c = 460. mm
- σ_o = √σ²+3τ² = 230.2 N/mm²

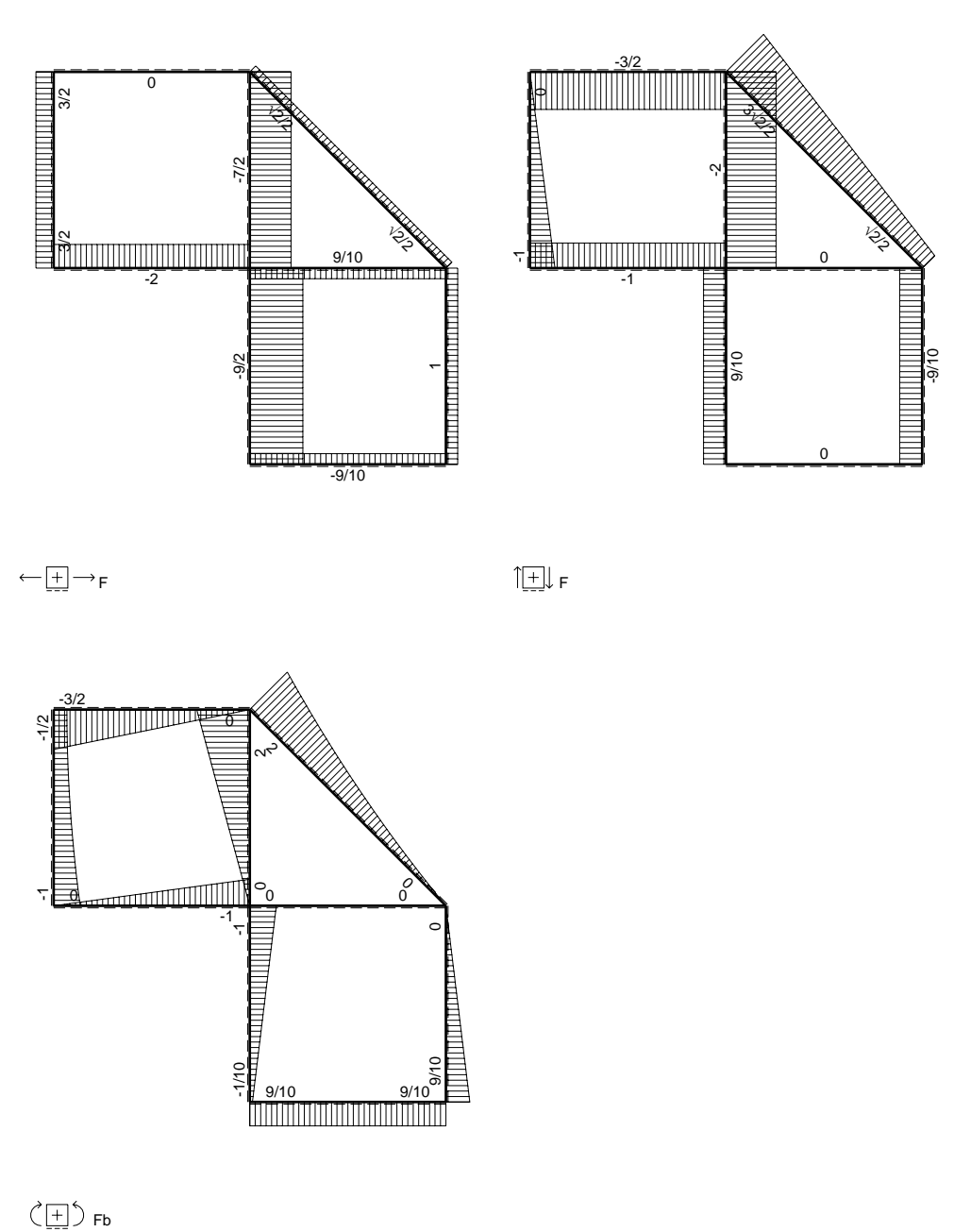
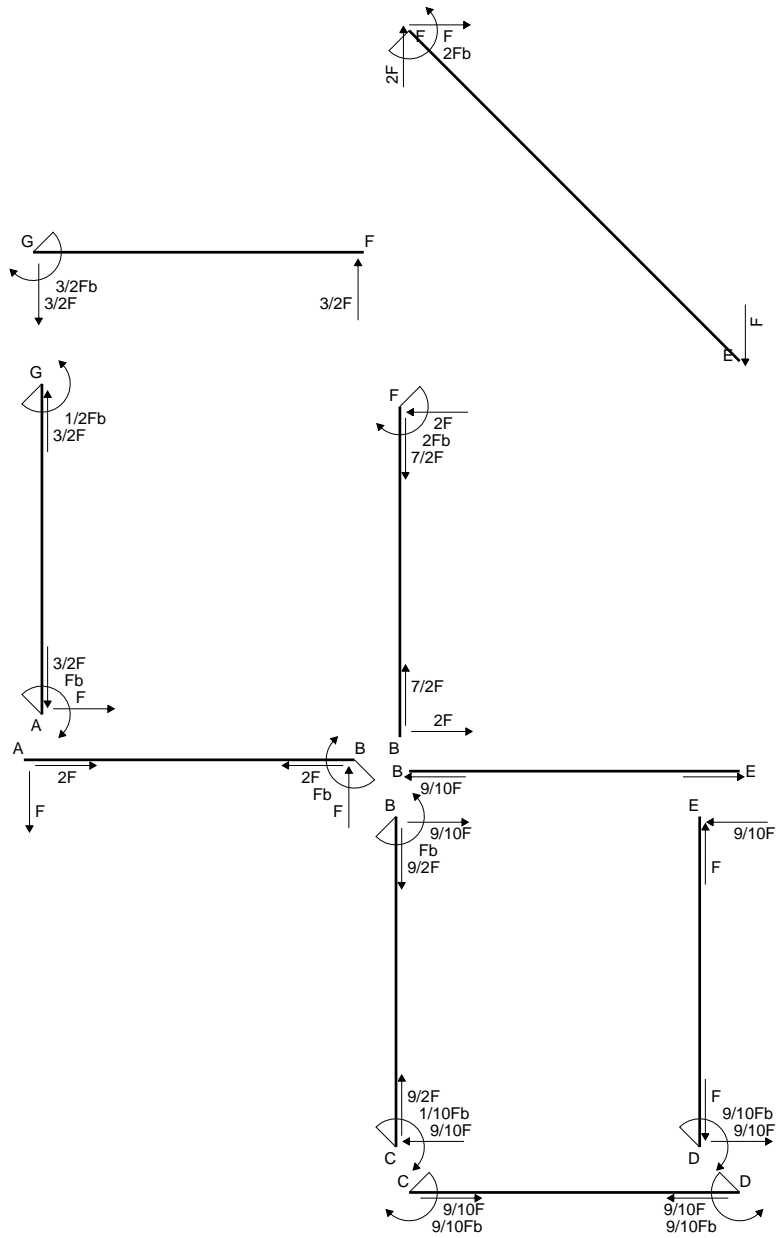

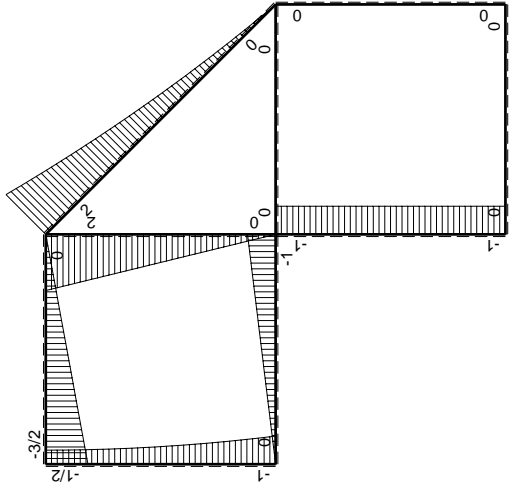
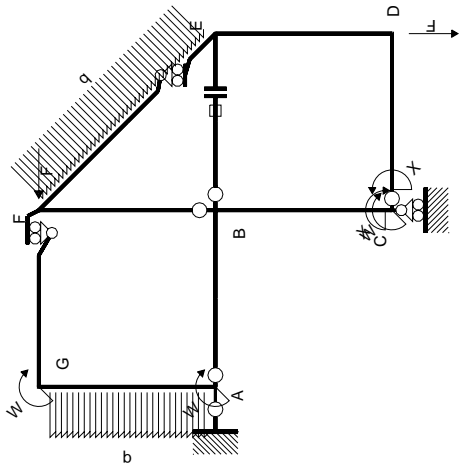

Schema di calcolo iperstatico

M_0 flessione da carichi assegnati

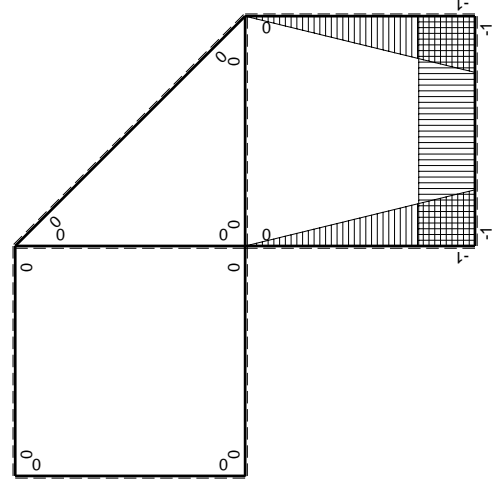

M_x flessione da iperstatica $X=1$

Quadro contribuiti PLV per iperstatica $X=W_{cd}$

\rightarrow	$M_x(x)$	$M_0(x)$	$M_x M_0$	$M_x M_x$	$\int M_x M_0 / EJ dx$	$\int M_x M_x / EJ dx$
AB b	0	-Fx	0	0	0	0
BA b	0	Fb-Fx	0	0	0	0
BC b	-x/b	-Fb	Fx	x^2/b^2	$1/2 Fb^2/EJ$	$1/3 Xb/EJ$
CB b	$1-x/b$	Fb	Fb-Fx	$1-2x/b+x^2/b^2$		
CD b	-1	0	0	1	0	Xb/EJ
DC b	1	0	0	1	0	
DE b	$-1+x/b$	0	0	$1-2x/b+x^2/b^2$	0	$1/3 Xb/EJ$
ED b	x/b	0	0	x^2/b^2	0	0
EF $\sqrt{2}b$	0	$\sqrt{2}/2 Fx + 1/2 qx^2$	0	0	0	0
FG b	0	-3/2 Fx	0	0	0	0
GF b	0	$3/2 Fb - 3/2 Fx$	0	0	0	0
GA b	0	$-1/2 Fb - 1/2 qx^2$	0	0	0	0
AG b	0	$Fb - Fx + 1/2 qx^2$	0	0	0	0
FB b	0	$2Fb - 2Fx$	0	0	0	0
BF b	0	-2Fx	0	0	0	0
BE b	0	0	0	0	0	0
EB b	0	0	0	0	0	0
BE	elongazione asta $N_{1, BE} \epsilon_{BE} = L_{BE}$				Fb^2/EJ	
	totali				$3/2 Fb^2/EJ$	$5/3 Xb/EJ$
	iperstatica $X=W_{cd}$				$-9/10 Fb$	

Sviluppi di calcolo iperstatica

$$L_{BC}^{xx} = \int_0^b (x^2/b^2) 1/EJ dx = [1/3 x^3/b^2]_0^b 1/EJ$$

$$= (1/3 b) 1/EJ = 1/3 b/EJ$$

$$L_{CB}^{xx} = \int_0^b (1 - 2x/b + x^2/b^2) 1/EJ dx = [x - x^2/b + 1/3 x^3/b^2]_0^b 1/EJ$$

$$= (b - b + 1/3 b) 1/EJ = 1/3 b/EJ$$

$$L_{CD}^{xx} = \int_0^b (1) 1/EJ dx = [x]_0^b 1/EJ$$

$$= (b) 1/EJ = b/EJ$$

$$L_{DC}^{xx} = \int_0^b (1) 1/EJ dx = [x]_0^b 1/EJ$$

$$= (b) 1/EJ = b/EJ$$

$$L_{DE}^{xx} = \int_0^b (1 - 2x/b + x^2/b^2) 1/EJ dx = [x - x^2/b + 1/3 x^3/b^2]_0^b 1/EJ$$

$$= (b - b + 1/3 b) 1/EJ = 1/3 b/EJ$$

$$L_{ED}^{xx} = \int_0^b (x^2/b^2) 1/EJ dx = [1/3 x^3/b^2]_0^b 1/EJ$$

$$= (1/3 b) 1/EJ = 1/3 b/EJ$$

$$L_{BC}^{xo} = \int_0^b (x/b) Fb 1/EJ dx = [1/2 x^2/b]_0^b Fb 1/EJ$$

$$= (1/2 b) Fb 1/EJ = 1/2 Fb^2/EJ$$

$$L_{CB}^{xo} = \int_0^b (1 - x/b) Fb 1/EJ dx = [x - 1/2 x^2/b]_0^b Fb 1/EJ$$

$$= (b - 1/2 b) Fb 1/EJ = 1/2 Fb^2/EJ$$

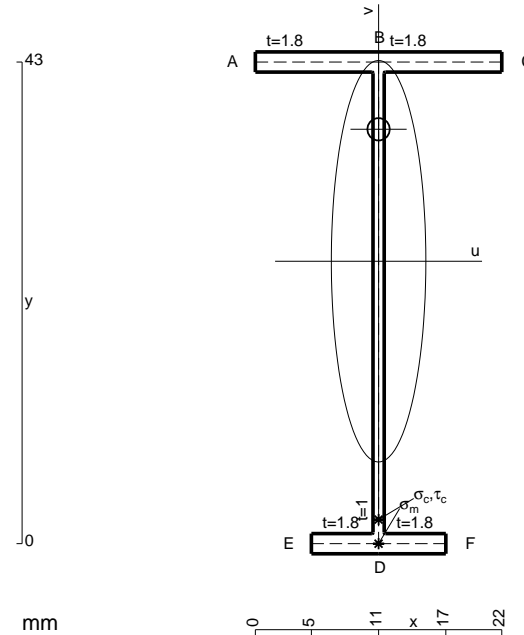

- A = 104.2 mm²
- J_u = 33478. mm⁴
- J_v = 1856. mm⁴
- J_t = 80.43 mm⁴
- y_o = 11.78 mm
- y_g = 25.21 mm
- N = 190.9 N
- T_y = 572.8 N
- M_x = 307800. Nmm
- x_m = 11. mm
- v_m = -25.21 mm
- σ_m = N/A-Mv/J_u = 233.7 N/mm²
- y_c = 3. mm
- u_c = -11. mm
- v_c = -22.21 mm
- σ_c = N/A-Mv/J_u = 233.7 N/mm²
- τ_c = TS'/tJ_u = 9.318 N/mm²
- τ_g = TS'/tJ_u = 9.318 N/mm²
- t_c = 270. mm
- σ_o = √σ²+3τ² = 234.2 N/mm²

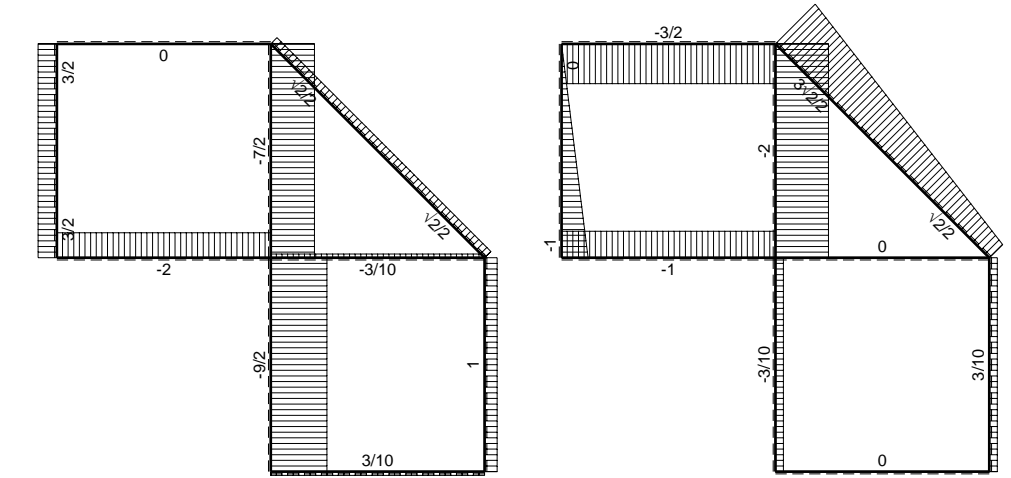
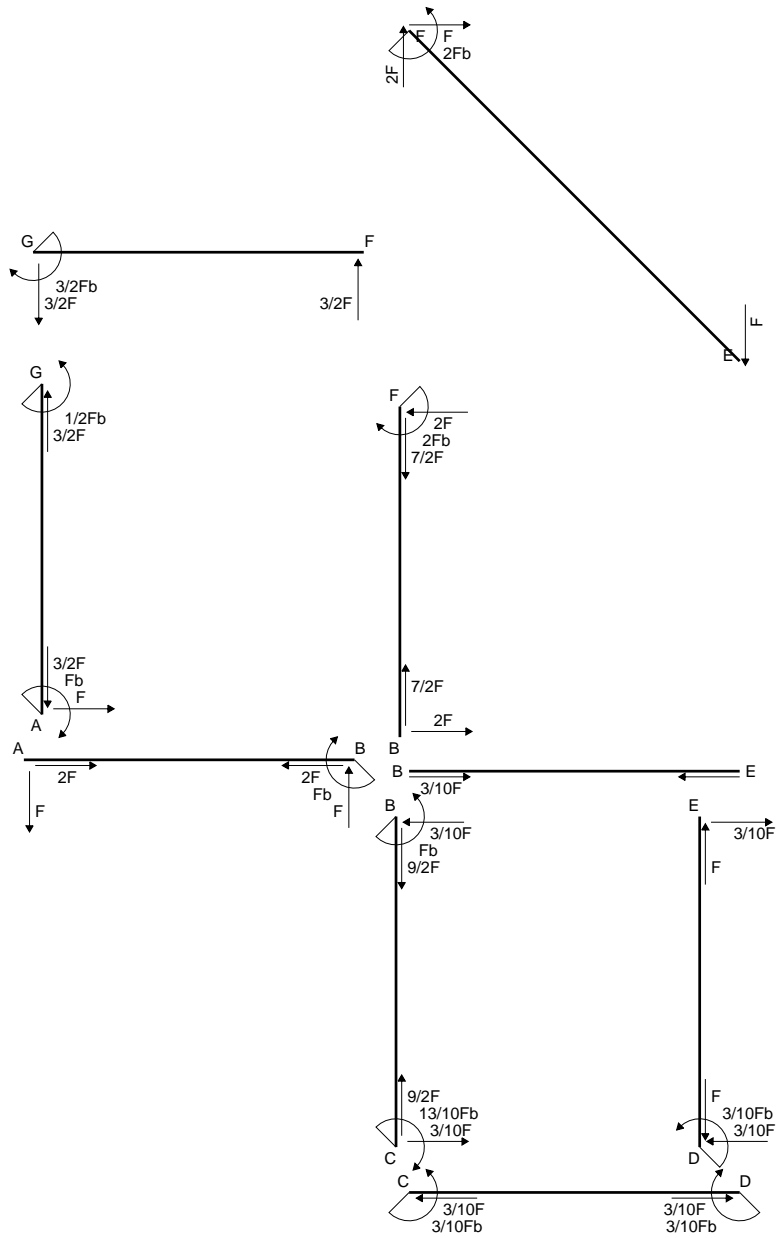

← ⊕ → F

↑ ⊕ ↓ F

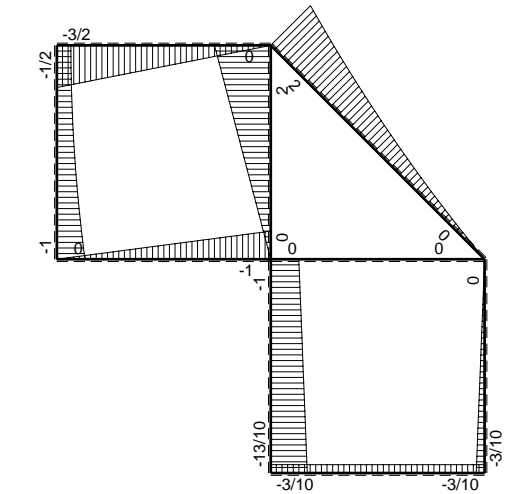

⊕ ⊖ F_b

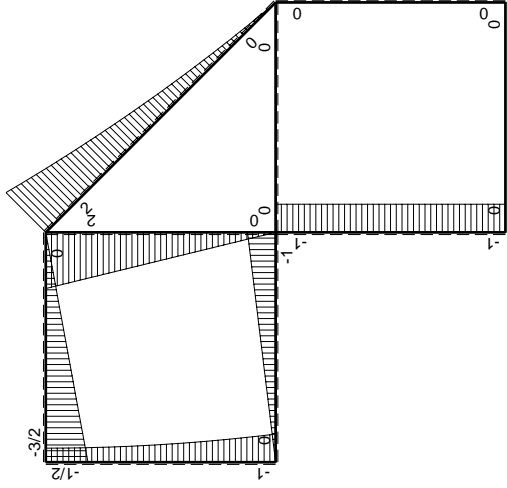
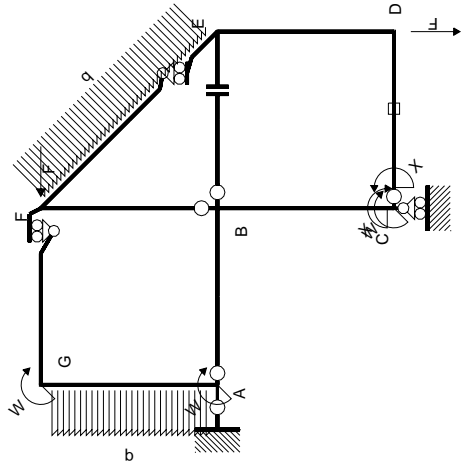

Schema di calcolo iperstatico

M_0 flessione da carichi assegnati

Quadro contributi PLV per iperstatica $X=W_{cd}$

\rightarrow	$M_x(x)$	$M_0(x)$	$M_x M_0$	$M_x M_x$	$\int M_x M_0 / EJ dx$	$\int X M_x M_x / EJ dx$
AB b	0	-Fx	0	0	0	0
BA b	0	Fb-Fx	0	0	0	0
BC b	-x/b	-Fb	Fx	x^2/b^2	$1/2 Fb^2/EJ$	$1/3 Xb/EJ$
CB b	$1-x/b$	Fb	Fb-Fx	$1-2x/b+x^2/b^2$		
CD b	-1	0	0	1	0	Xb/EJ
DC b	1	0	0	1	0	
DE b	$-1+x/b$	0	0	$1-2x/b+x^2/b^2$	0	$1/3 Xb/EJ$
ED b	x/b	0	0	x^2/b^2	0	0
EF $\sqrt{2}b$	0	$\sqrt{2}/2 Fx + 1/2 qx^2$	0	0	0	0
FG b	0	-3/2 Fx	0	0	0	0
GF b	0	3/2 Fb - 3/2 Fx	0	0	0	0
GA b	0	$-1/2 Fb - 1/2 qx^2$	0	0	0	0
AG b	0	$Fb - Fx + 1/2 qx^2$	0	0	0	0
FB b	0	2Fb - 2Fx	0	0	0	0
BF b	0	-2Fx	0	0	0	0
BE b	0	0	0	0	0	0
EB b	0	0	0	0	0	0
CD	elongazione asta $N_{1,cd} \epsilon_{cd} L_{cd}$				$-Fb^2/EJ$	
	totali				$-1/2 Fb^2/EJ$	$5/3 Xb/EJ$
	iperstatica $X=W_{cd}$				$3/10 Fb$	

Sviluppi di calcolo iperstatica

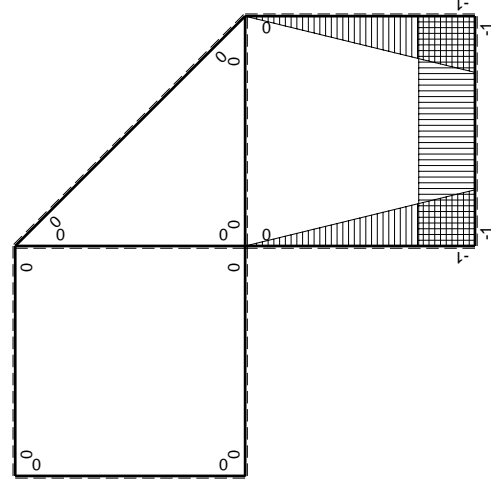

M_x flessione da iperstatica $X=1$

$$L_{BC}^{xx} = \int_0^b (x^2/b^2) 1/EJ dx = [1/3 x^3/b^2]_0^b 1/EJ$$

$$= (1/3 b) 1/EJ = 1/3 b/EJ$$

$$L_{CB}^{xx} = \int_0^b (1 - 2x/b + x^2/b^2) 1/EJ dx = [x - x^2/b + 1/3 x^3/b^2]_0^b 1/EJ$$

$$= (b - b + 1/3 b) 1/EJ = 1/3 b/EJ$$

$$L_{CD}^{xx} = \int_0^b (1) 1/EJ dx = [x]_0^b 1/EJ$$

$$= (b) 1/EJ = b/EJ$$

$$L_{DC}^{xx} = \int_0^b (1) 1/EJ dx = [x]_0^b 1/EJ$$

$$= (b) 1/EJ = b/EJ$$

$$L_{DE}^{xx} = \int_0^b (1 - 2x/b + x^2/b^2) 1/EJ dx = [x - x^2/b + 1/3 x^3/b^2]_0^b 1/EJ$$

$$= (b - b + 1/3 b) 1/EJ = 1/3 b/EJ$$

$$L_{ED}^{xx} = \int_0^b (x^2/b^2) 1/EJ dx = [1/3 x^3/b^2]_0^b 1/EJ$$

$$= (1/3 b) 1/EJ = 1/3 b/EJ$$

$$L_{BC}^{xo} = \int_0^b (x/b) Fb 1/EJ dx = [1/2 x^2/b]_0^b Fb 1/EJ$$

$$= (1/2 b) Fb 1/EJ = 1/2 Fb^2/EJ$$

$$L_{CB}^{xo} = \int_0^b (1 - x/b) Fb 1/EJ dx = [x - 1/2 x^2/b]_0^b Fb 1/EJ$$

$$= (b - 1/2 b) Fb 1/EJ = 1/2 Fb^2/EJ$$

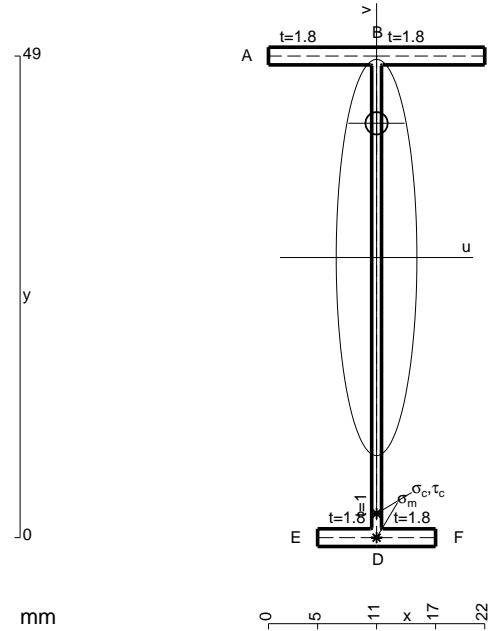

- A = 110.2 mm²
- J_u = 44775. mm⁴
- J_v = 1856. mm⁴
- J_t = 82.43 mm⁴
- y_o = 13.66 mm
- y_g = 28.5 mm
- N = 155.6 N
- T_y = 466.7 N
- M_x = 303600. Nmm
- x_m = 11. mm
- v_m = -28.5 mm
- σ_m = N/A - Mv/J_u = 194.7 N/mm²
- y_c = 3. mm
- u_c = -11. mm
- v_c = -25.5 mm
- σ_c = N/A - Mv/J_u = 194.7 N/mm²
- τ_c = TS⁺/tJ_u = 6.417 N/mm²
- τ_g = TS⁺/tJ_u = 6.417 N/mm²
- t_c = 220. mm
- σ_o = √σ² + 3τ² = 195. N/mm²

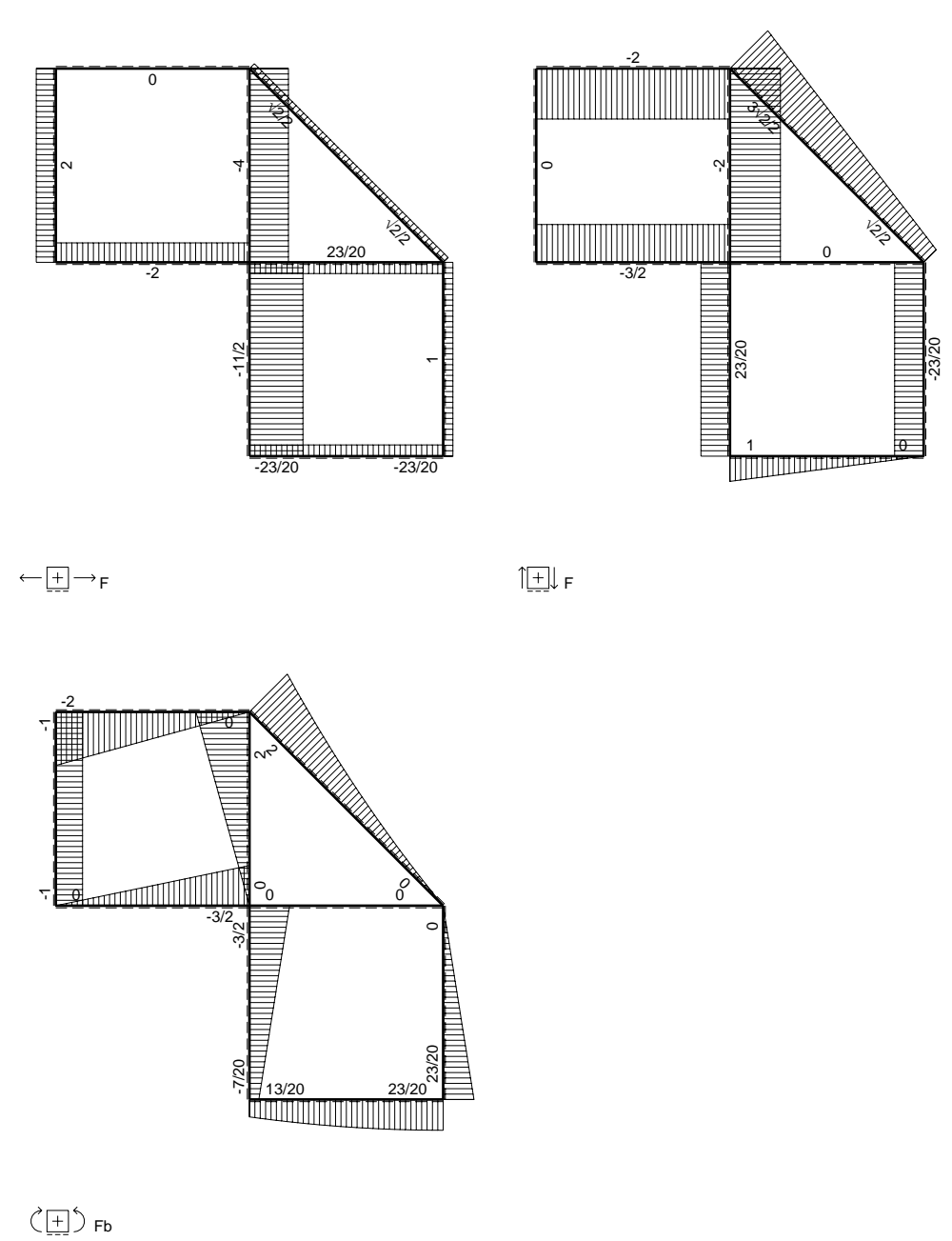
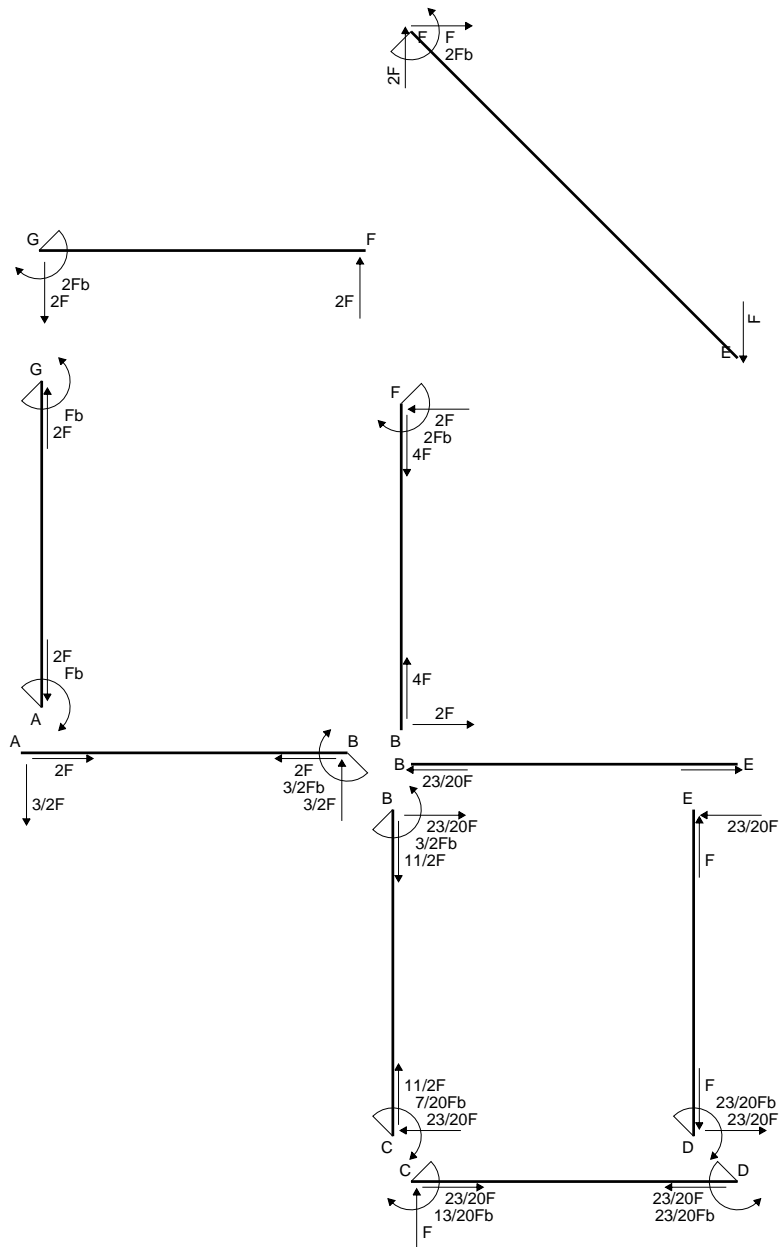

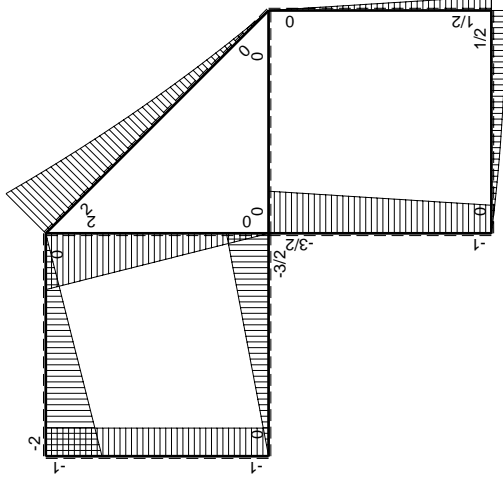
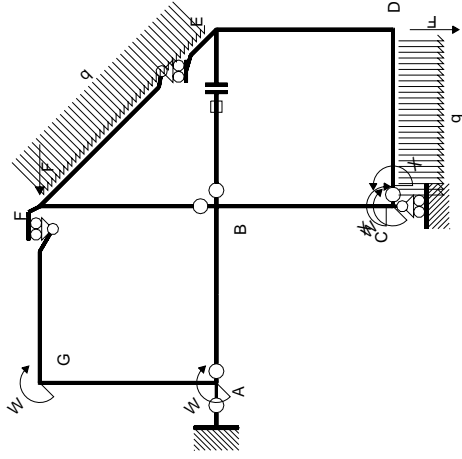

(\oplus) M_0 flessione da carichi assegnati

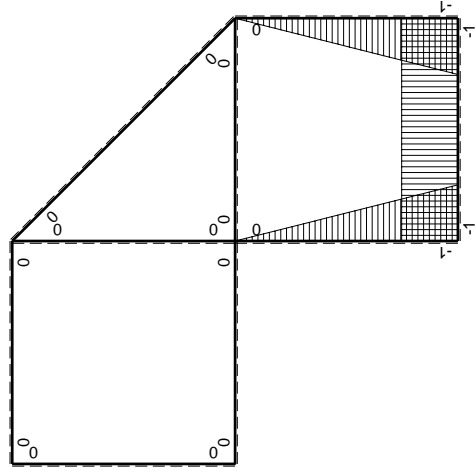

(\oplus) M_x flessione da iperstatica $X=1$

Quadro contribuiti PLV per iperstatica $X=W_{cd}$

\rightarrow	$M_x(x)$	$M_0(x)$	$M_x M_0$	$M_x M_x$	$\int M_x M_0 / EJ dx$	$\int M_x M_x / EJ dx$
AB b	0	-3/2Fx	0	0	0	0
BA b	0	3/2Fb-3/2Fx	0	0	0	0
BC b	-x/b	-3/2Fb+1/2Fx	3/2Fx-1/2Fx ² /b	x ² /b ²	7/12Fb ² /EJ	1/3Xb/EJ
CB b	1-x/b	Fb+1/2Fx	Fb-1/2Fx-1/2Fx ² /b	1-2x/b+x ² /b ²	-1/3Fb ² /EJ	Xb/EJ
CD b	-1	Fx-1/2qx ²	-Fx+1/2Fx ² /b	1	-1/6Fb ² /EJ	1/3Xb/EJ
DC b	1	-1/2Fb+1/2qx ²	-1/2Fb+1/2Fx ² /b	1	0	0
DE b	-1+x/b	1/2Fb-1/2Fx	-1/2Fb+Fx-1/2Fx ² /b	1-2x/b+x ² /b ²	-1/6Fb ² /EJ	1/3Xb/EJ
ED b	x/b	-1/2Fx	-1/2Fx ² /b	x ² /b ²	0	0
EF $\sqrt{2}b$	0	$\sqrt{2}/2Fx+1/2qx^2$	0	0	0	0
FG b	0	-2Fx	0	0	0	0
GF b	0	2Fb-2Fx	0	0	0	0
GA b	0	-Fb	0	0	0	0
AG b	0	Fb	0	0	0	0
FB b	0	2Fb-2Fx	0	0	0	0
BF b	0	-2Fx	0	0	0	0
BE b	0	0	0	0	0	0
EB b	0	0	0	0	0	0
BE	elongazione asta $N_{1, BE} \epsilon_{BE} L_{BE}$				Fb ² /EJ	
	totali				13/12Fb ² /EJ	5/3Xb/EJ
	iperstatica $X=W_{cd}$				-13/20Fb	

Sviluppi di calcolo iperstatica

$$L_{BC}^{xx} = \int_0^b (x^2/b^2) 1/EJ dx = [1/3 x^3/b^2]_0^b 1/EJ$$

$$= (1/3 b) 1/EJ = 1/3 b/EJ$$

$$L_{CB}^{xx} = \int_0^b (1 - 2x/b + x^2/b^2) 1/EJ dx = [x - x^2/b + 1/3 x^3/b^2]_0^b 1/EJ$$

$$= (b - b + 1/3 b) 1/EJ = 1/3 b/EJ$$

$$L_{CD}^{xx} = \int_0^b (1) 1/EJ dx = [x]_0^b 1/EJ$$

$$= (b) 1/EJ = b/EJ$$

$$L_{DC}^{xx} = \int_0^b (1) 1/EJ dx = [x]_0^b 1/EJ$$

$$= (b) 1/EJ = b/EJ$$

$$L_{DE}^{xx} = \int_0^b (1 - 2x/b + x^2/b^2) 1/EJ dx = [x - x^2/b + 1/3 x^3/b^2]_0^b 1/EJ$$

$$= (b - b + 1/3 b) 1/EJ = 1/3 b/EJ$$

$$L_{ED}^{xx} = \int_0^b (x^2/b^2) 1/EJ dx = [1/3 x^3/b^2]_0^b 1/EJ$$

$$= (1/3 b) 1/EJ = 1/3 b/EJ$$

$$L_{BC}^{xo} = \int_0^b (3/2 x/b - 1/2 x^2/b^2) Fb 1/EJ dx = [3/4 x^2/b - 1/6 x^3/b^2]_0^b Fb 1/EJ$$

$$= (3/4 b - 1/6 b) Fb 1/EJ = 7/12 Fb^2/EJ$$

$$L_{CB}^{xo} = \int_0^b (1 - 1/2 x/b - 1/2 x^2/b^2) Fb 1/EJ dx = [x - 1/4 x^2/b - 1/6 x^3/b^2]_0^b Fb 1/EJ$$

$$= (b - 1/4 b - 1/6 b) Fb 1/EJ = 7/12 Fb^2/EJ$$

$$L_{CD}^{xo} = \int_0^b (-x/b + 1/2 x^2/b^2) Fb 1/EJ dx = [-1/2 x^2/b + 1/6 x^3/b^2]_0^b Fb 1/EJ$$

$$= (-1/2 b + 1/6 b) Fb 1/EJ = -1/3 Fb^2/EJ$$

$$L_{DC}^{xo} = \int_0^b (-1/2 + 1/2 x^2/b^2) Fb 1/EJ dx = [-1/2 x + 1/6 x^3/b^2]_0^b Fb 1/EJ$$

$$= (-1/2 b + 1/6 b) Fb 1/EJ = -1/3 Fb^2/EJ$$

$$L_{DE}^{xo} = \int_0^b (-1/2 + x/b - 1/2 x^2/b^2) Fb 1/EJ dx = [-1/2 x + 1/2 x^2/b - 1/6 x^3/b^2]_0^b Fb 1/EJ$$

$$= (-1/2 b + 1/2 b - 1/6 b) Fb 1/EJ = -1/6 Fb^2/EJ$$

$$L_{ED}^{xo} = \int_0^b (-1/2 x^2/b^2) Fb 1/EJ dx = [-1/6 x^3/b^2]_0^b Fb 1/EJ$$

$$= (-1/6 b) Fb 1/EJ = -1/6 Fb^2/EJ$$

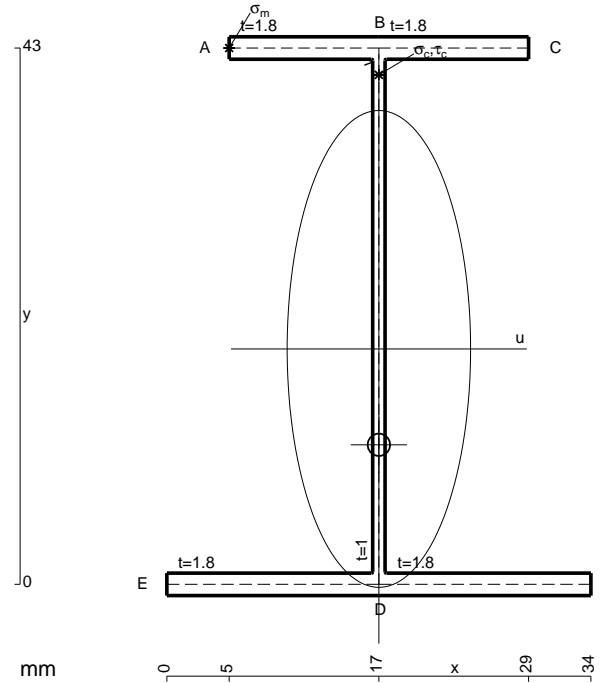

- A = 147.4 mm²
- J_u = 53868. mm⁴
- J_v = 7969. mm⁴
- J_i = 127.1 mm⁴
- y_o = -7.686 mm
- y_g = 18.87 mm
- N = 254.6 N
- T_y = 763.7 N
- M_x = 468000. Nmm
- x_m = 5. mm
- y_m = 43. mm
- u_m = -12. mm
- v_m = 24.13 mm
- σ_m = N/A-Mv/J_u = -207.9 N/mm²
- x_c = 17. mm
- y_c = 43. mm
- v_c = 24.13 mm
- σ_c = N/A-Mv/J_u = -207.9 N/mm²
- τ_c = TS/tJ_u = 14.78 N/mm²
- τ_g = TS/tJ_u = 14.78 N/mm²
- t_c = 360. mm
- σ_o = √σ²+3τ² = 209.4 N/mm²

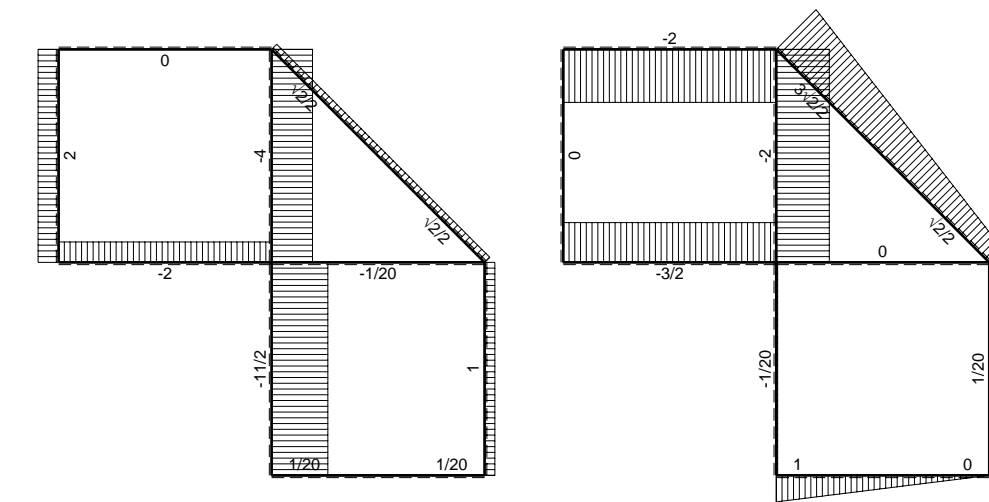
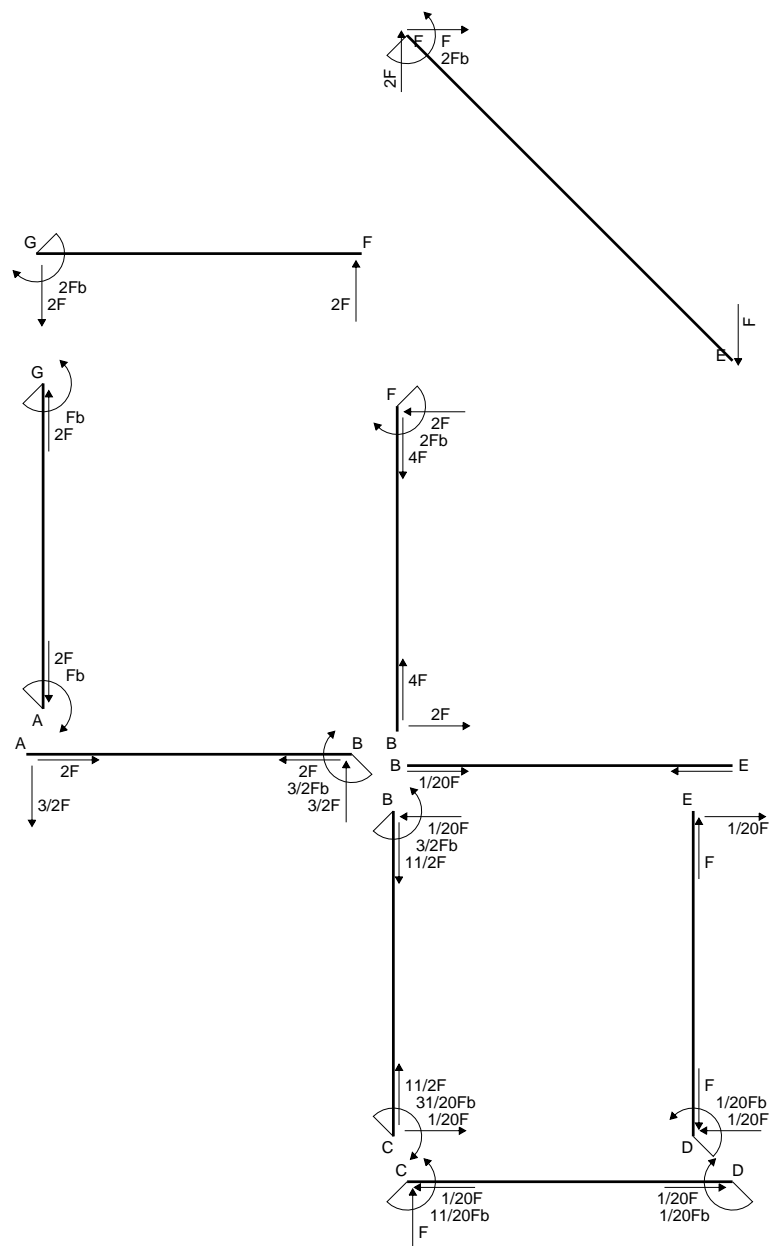

← ⊕ → F

↑ ⊕ ↓ F

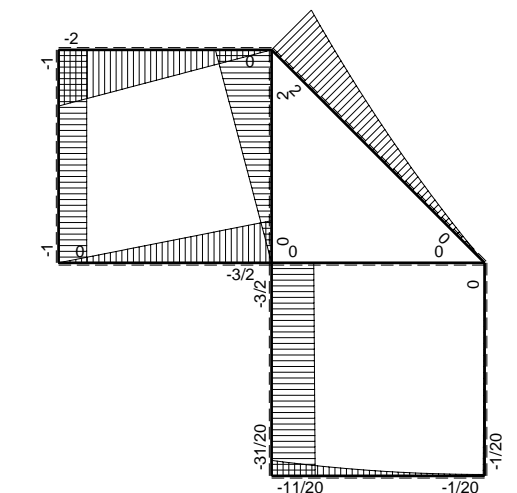

⊕ ⊖ Fb

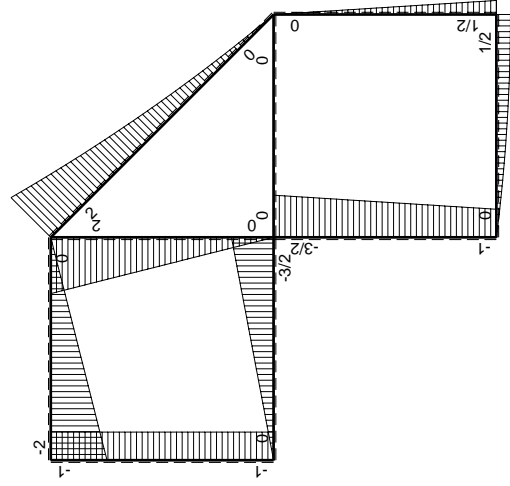
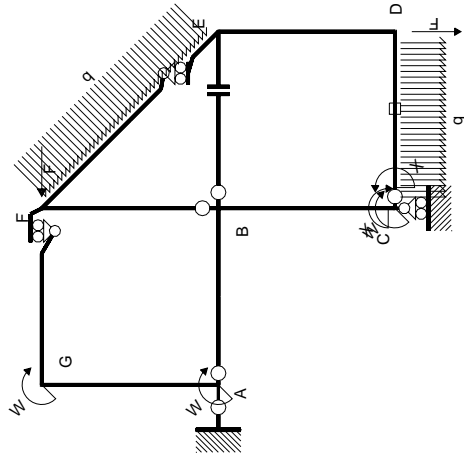

(\oplus) M_0 flessione da carichi assegnati

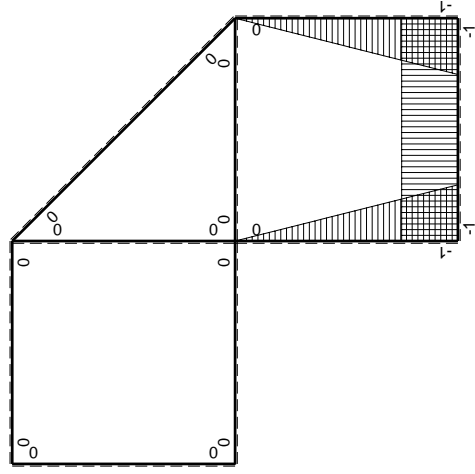

(\oplus) M_x flessione da iperstatica $X=1$

Quadro contribuiti PLV per iperstatica $X=W_{cd}$

\rightarrow	$M_x(x)$	$M_0(x)$	$M_x M_0$	$M_x M_x$	$\int M_x M_0 / EJ dx$	$\int X M_x M_x / EJ dx$
AB b	0	-3/2Fx	0	0	0	0
BA b	0	3/2Fb-3/2Fx	0	0	0	0
BC b	-x/b	-3/2Fb+1/2Fx	3/2Fx-1/2Fx ² /b	x ² /b ²	7/12Fb ² /EJ	1/3Xb/EJ
CB b	1-x/b	Fb+1/2Fx	Fb-1/2Fx-1/2Fx ² /b	1-2x/b+x ² /b ²	-1/3Fb ² /EJ	Xb/EJ
CD b	-1	Fx-1/2qx ²	-Fx+1/2Fx ² /b	1	-1/3Fb ² /EJ	Xb/EJ
DC b	1	-1/2Fb+1/2qx ²	-1/2Fb+1/2Fx ² /b	1	-1/3Fb ² /EJ	Xb/EJ
DE b	-1+x/b	1/2Fb-1/2Fx	-1/2Fb+Fx-1/2Fx ² /b	1-2x/b+x ² /b ²	-1/6Fb ² /EJ	1/3Xb/EJ
ED b	x/b	-1/2Fx	-1/2Fx ² /b	x ² /b ²	0	0
EF $\sqrt{2}b$	0	$\sqrt{2}/2Fx+1/2qx^2$	0	0	0	0
FG b	0	-2Fx	0	0	0	0
GF b	0	2Fb-2Fx	0	0	0	0
GA b	0	-Fb	0	0	0	0
AG b	0	Fb	0	0	0	0
FB b	0	2Fb-2Fx	0	0	0	0
BF b	0	-2Fx	0	0	0	0
BE b	0	0	0	0	0	0
EB b	0	0	0	0	0	0
CD	elongazione asta $N_{1,cd} \epsilon_{cd} L_{cd}$				-Fb ² /EJ	
	totali				-11/12Fb ² /EJ	5/3Xb/EJ
	iperstatica $X=W_{cd}$				11/20Fb	

Sviluppi di calcolo iperstatica

$$L_{BC}^{xx} = \int_0^b (x^2/b^2) 1/EJ dx = [1/3 x^3/b^2]_0^b 1/EJ$$

$$= (1/3 b) 1/EJ = 1/3 b/EJ$$

$$L_{CB}^{xx} = \int_0^b (1 - 2x/b + x^2/b^2) 1/EJ dx = [x - x^2/b + 1/3 x^3/b^2]_0^b 1/EJ$$

$$= (b - b + 1/3 b) 1/EJ = 1/3 b/EJ$$

$$L_{CD}^{xx} = \int_0^b (1) 1/EJ dx = [x]_0^b 1/EJ$$

$$= (b) 1/EJ = b/EJ$$

$$L_{DC}^{xx} = \int_0^b (1) 1/EJ dx = [x]_0^b 1/EJ$$

$$= (b) 1/EJ = b/EJ$$

$$L_{DE}^{xx} = \int_0^b (1 - 2x/b + x^2/b^2) 1/EJ dx = [x - x^2/b + 1/3 x^3/b^2]_0^b 1/EJ$$

$$= (b - b + 1/3 b) 1/EJ = 1/3 b/EJ$$

$$L_{ED}^{xx} = \int_0^b (x^2/b^2) 1/EJ dx = [1/3 x^3/b^2]_0^b 1/EJ$$

$$= (1/3 b) 1/EJ = 1/3 b/EJ$$

$$L_{BC}^{xo} = \int_0^b (3/2 x/b - 1/2 x^2/b^2) Fb 1/EJ dx = [3/4 x^2/b - 1/6 x^3/b^2]_0^b Fb 1/EJ$$

$$= (3/4 b - 1/6 b) Fb 1/EJ = 7/12 Fb^2/EJ$$

$$L_{CB}^{xo} = \int_0^b (1 - 1/2 x/b - 1/2 x^2/b^2) Fb 1/EJ dx = [x - 1/4 x^2/b - 1/6 x^3/b^2]_0^b Fb 1/EJ$$

$$= (b - 1/4 b - 1/6 b) Fb 1/EJ = 7/12 Fb^2/EJ$$

$$L_{CD}^{xo} = \int_0^b (-x/b + 1/2 x^2/b^2) Fb 1/EJ dx + 1 (-1) 1 Fb^2/EJ$$

$$= [-1/2 x^2/b + 1/6 x^3/b^2]_0^b Fb 1/EJ + 1 (-1) 1 Fb^2/EJ$$

$$= (-1/2 b + 1/6 b) Fb 1/EJ + 1 (-1) 1 Fb^2/EJ = -4/3 Fb^2/EJ$$

$$L_{DC}^{xo} = \int_0^b (-1/2 + 1/2 x^2/b^2) Fb 1/EJ dx + 1 (-1) 1 Fb^2/EJ$$

$$= [-1/2 x + 1/6 x^3/b^2]_0^b Fb 1/EJ + 1 (-1) 1 Fb^2/EJ$$

$$= (-1/2 b + 1/6 b) Fb 1/EJ + 1 (-1) 1 Fb^2/EJ = -4/3 Fb^2/EJ$$

$$L_{DE}^{xo} = \int_0^b (-1/2 + x/b - 1/2 x^2/b^2) Fb 1/EJ dx = [-1/2 x + 1/2 x^2/b - 1/6 x^3/b^2]_0^b Fb 1/EJ$$

$$= (-1/2 b + 1/2 b - 1/6 b) Fb 1/EJ = -1/6 Fb^2/EJ$$

$$L_{ED}^{xo} = \int_0^b (-1/2 x^2/b^2) Fb 1/EJ dx = [-1/6 x^3/b^2]_0^b Fb 1/EJ$$

$$= (-1/6 b) Fb 1/EJ = -1/6 Fb^2/EJ$$

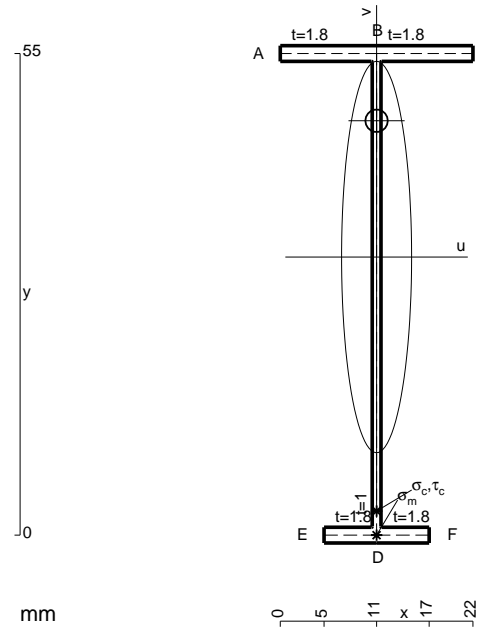

- A = 116.2 mm²
- J_u = 58038. mm⁴
- J_v = 1856. mm⁴
- J_t = 84.43 mm⁴
- y_o = 15.56 mm
- y_g = 31.76 mm
- N = 155.6 N
- T_y = 466.7 N
- M_x = 387200. Nmm
- x_m = 11. mm
- v_m = -31.76 mm
- σ_m = N/A-Mv/J_u = 213.2 N/mm²
- y_c = 3. mm
- u_c = -11. mm
- v_c = -28.76 mm
- σ_c = N/A-Mv/J_u = 213.2 N/mm²
- τ_c = TS¹/tJ_u = 5.516 N/mm²
- τ_g = TS¹/tJ_u = 5.516 N/mm²
- t_c = 220. mm
- σ_o = √σ²+3τ² = 213.4 N/mm²

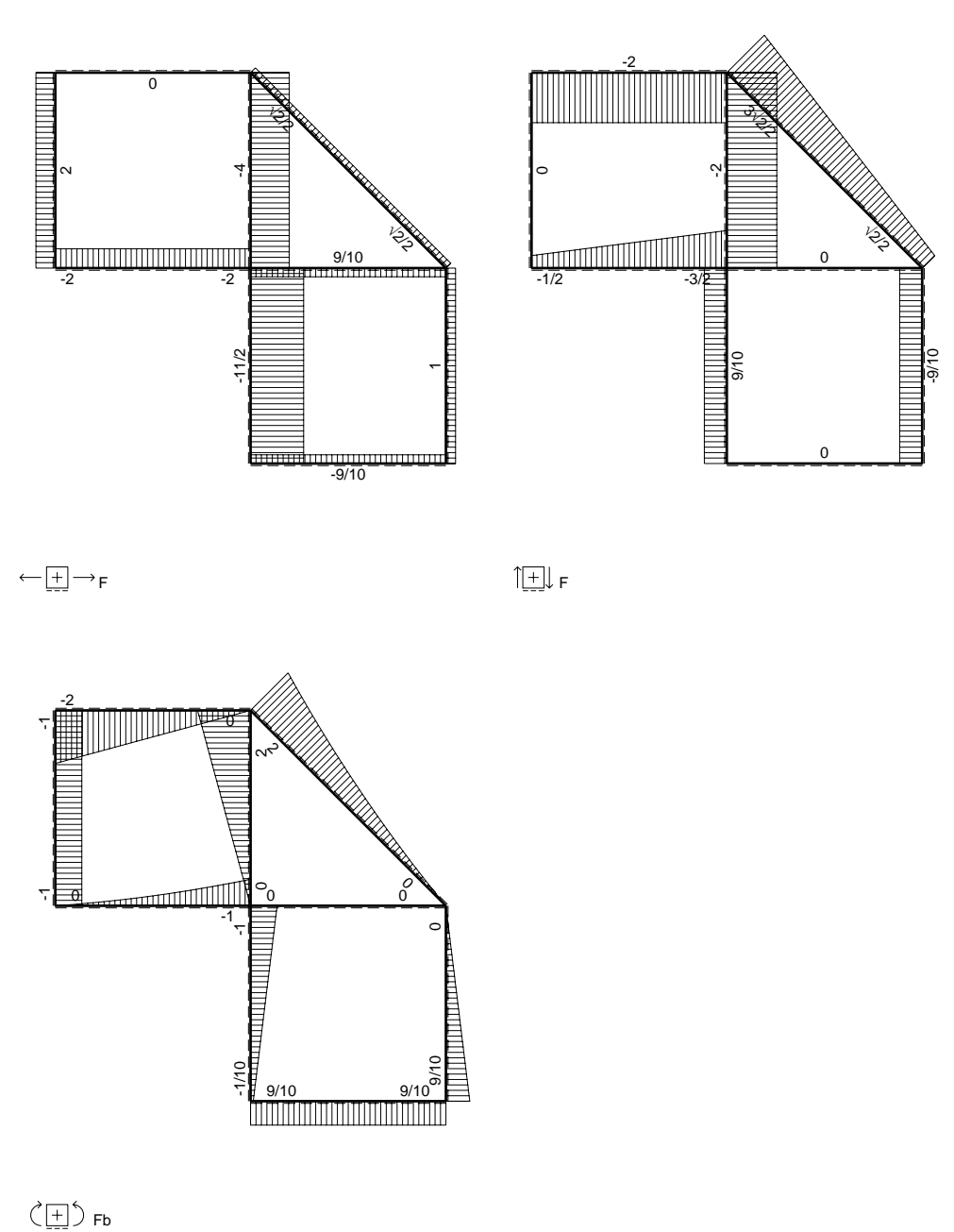
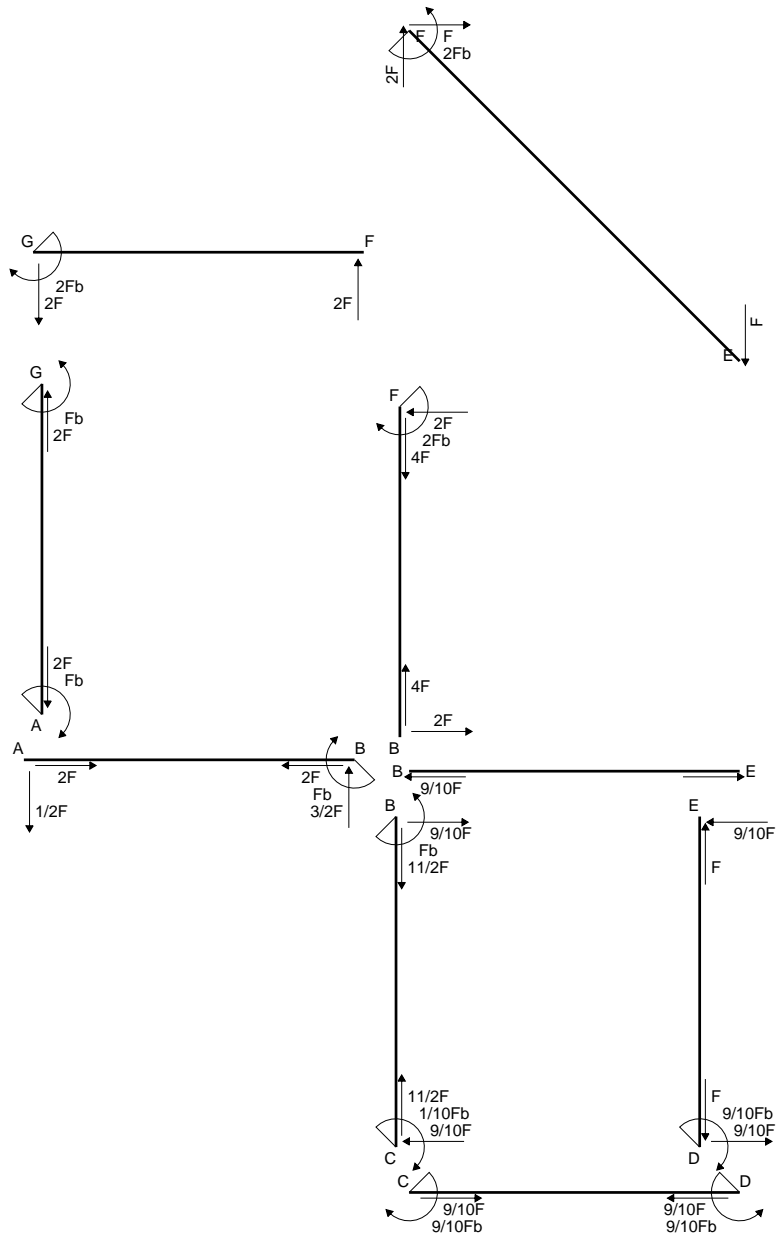

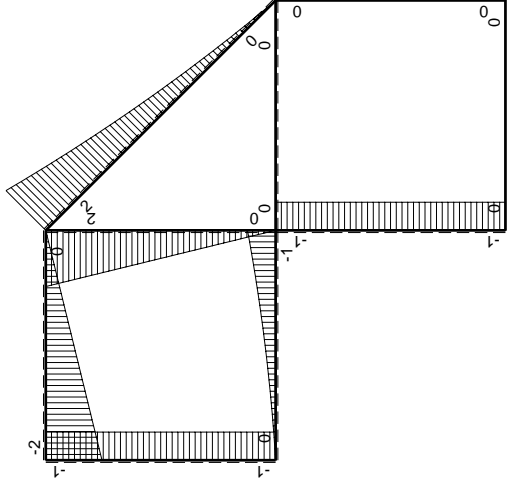
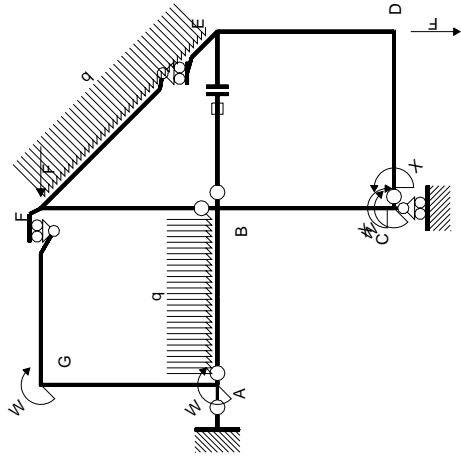

Schema di calcolo iperstatico

M_0 flessione da carichi assegnati

Quadro contribuiti PLV per iperstatica $X=W_{cd}$

\rightarrow	$M_x(x)$	$M_0(x)$	$M_x M_0$	$M_x M_x$	$\int M_x M_0 / E J dx$	$\int X M_x M_x / E J dx$
AB b	0	$-1/2Fx - 1/2qx^2$	0	0	0	0
BA b	0	$Fb - 3/2Fx + 1/2qx^2$	0	0	0	0
BC b	$-x/b$	$-Fb$	Fx	x^2/b^2	$1/2Fb^2/EJ$	$1/3Xb/EJ$
CB b	$1-x/b$	Fb	$Fb-Fx$	$1-2x/b+x^2/b^2$		
CD b	-1	0	0	1	0	Xb/EJ
DC b	1	0	0	1	0	0
DE b	$-1+x/b$	0	0	$1-2x/b+x^2/b^2$	0	$1/3Xb/EJ$
ED b	x/b	0	0	x^2/b^2	0	0
EF $\sqrt{2}b$	0	$\sqrt{2}/2Fx + 1/2qx^2$	0	0	0	0
FG b	0	$-2Fx$	0	0	0	0
GF b	0	$2Fb-2Fx$	0	0	0	0
GA b	0	$-Fb$	0	0	0	0
AG b	0	Fb	0	0	0	0
FB b	0	$2Fb-2Fx$	0	0	0	0
BF b	0	$-2Fx$	0	0	0	0
BE b	0	0	0	0	0	0
EB b	0	0	0	0	0	0
BE	elongazione asta $N_{1, BE} \epsilon_{BE} L_{BE}$				Fb^2/EJ	
	totali				$3/2Fb^2/EJ$	$5/3Xb/EJ$
	iperstatica $X=W_{cd}$				$-9/10Fb$	

Sviluppi di calcolo iperstatica

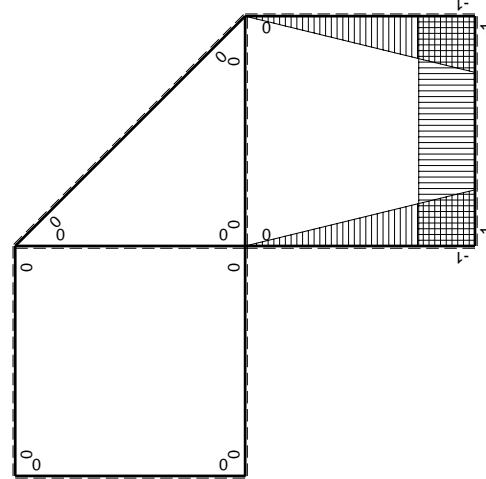

M_x flessione da iperstatica $X=1$

$$L_{BC}^{xx} = \int_0^b (x^2/b^2) 1/EJ dx = [1/3 x^3/b^2]_0^b 1/EJ$$

$$= (1/3 b) 1/EJ = 1/3 b/EJ$$

$$L_{CB}^{xx} = \int_0^b (1 - 2x/b + x^2/b^2) 1/EJ dx = [x - x^2/b + 1/3 x^3/b^2]_0^b 1/EJ$$

$$= (b - b + 1/3 b) 1/EJ = 1/3 b/EJ$$

$$L_{CD}^{xx} = \int_0^b (1) 1/EJ dx = [x]_0^b 1/EJ$$

$$= (b) 1/EJ = b/EJ$$

$$L_{DC}^{xx} = \int_0^b (1) 1/EJ dx = [x]_0^b 1/EJ$$

$$= (b) 1/EJ = b/EJ$$

$$L_{DE}^{xx} = \int_0^b (1 - 2x/b + x^2/b^2) 1/EJ dx = [x - x^2/b + 1/3 x^3/b^2]_0^b 1/EJ$$

$$= (b - b + 1/3 b) 1/EJ = 1/3 b/EJ$$

$$L_{ED}^{xx} = \int_0^b (x^2/b^2) 1/EJ dx = [1/3 x^3/b^2]_0^b 1/EJ$$

$$= (1/3 b) 1/EJ = 1/3 b/EJ$$

$$L_{BC}^{xo} = \int_0^b (x/b) Fb 1/EJ dx = [1/2 x^2/b]_0^b Fb 1/EJ$$

$$= (1/2 b) Fb 1/EJ = 1/2 Fb^2/EJ$$

$$L_{CB}^{xo} = \int_0^b (1 - x/b) Fb 1/EJ dx = [x - 1/2 x^2/b]_0^b Fb 1/EJ$$

$$= (b - 1/2 b) Fb 1/EJ = 1/2 Fb^2/EJ$$

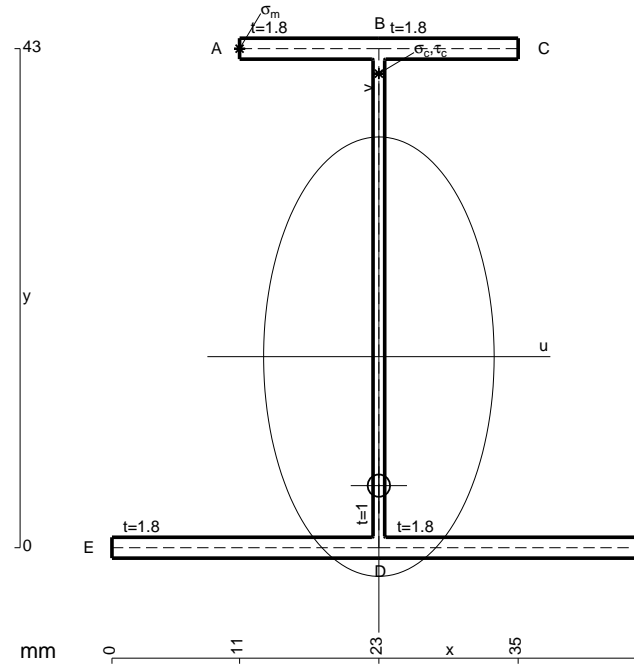

- A = 169. mm²
- J_u = 60580. mm⁴
- J_v = 16674. mm⁴
- J_i = 150.4 mm⁴
- y_o = -11.11 mm
- y_g = 16.46 mm
- N = 254.6 N
- T_y = 763.7 N
- M_x = 525600. Nmm
- x_m = 11. mm
- y_m = 43. mm
- u_m = -12. mm
- v_m = 26.54 mm
- σ_m = N/A-Mv/J_u = -228.7 N/mm²
- x_c = 23. mm
- y_c = 43. mm
- v_c = 26.54 mm
- σ_c = N/A-Mv/J_u = -228.7 N/mm²
- τ_c = TS/tJ_u = 14.45 N/mm²
- τ_g = TS/tJ_u = 14.45 N/mm²
- t_c = 360. mm
- σ_o = √σ²+3τ² = 230.1 N/mm²

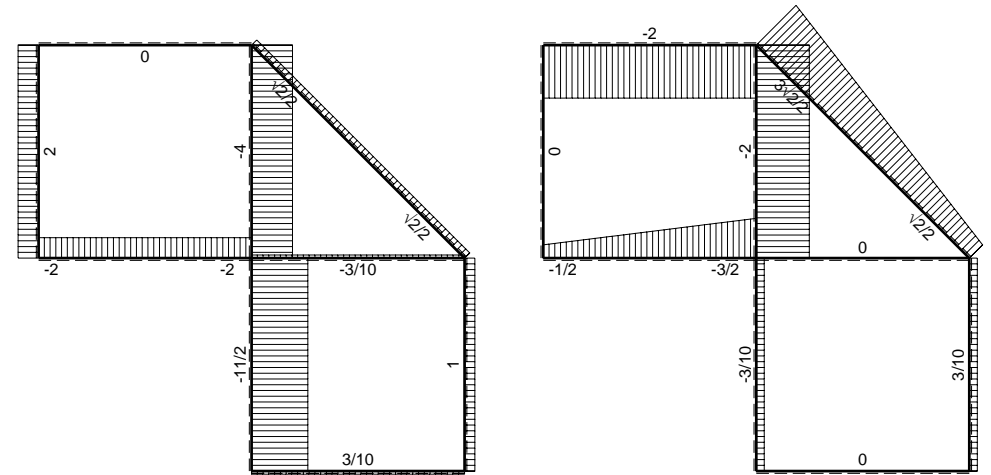
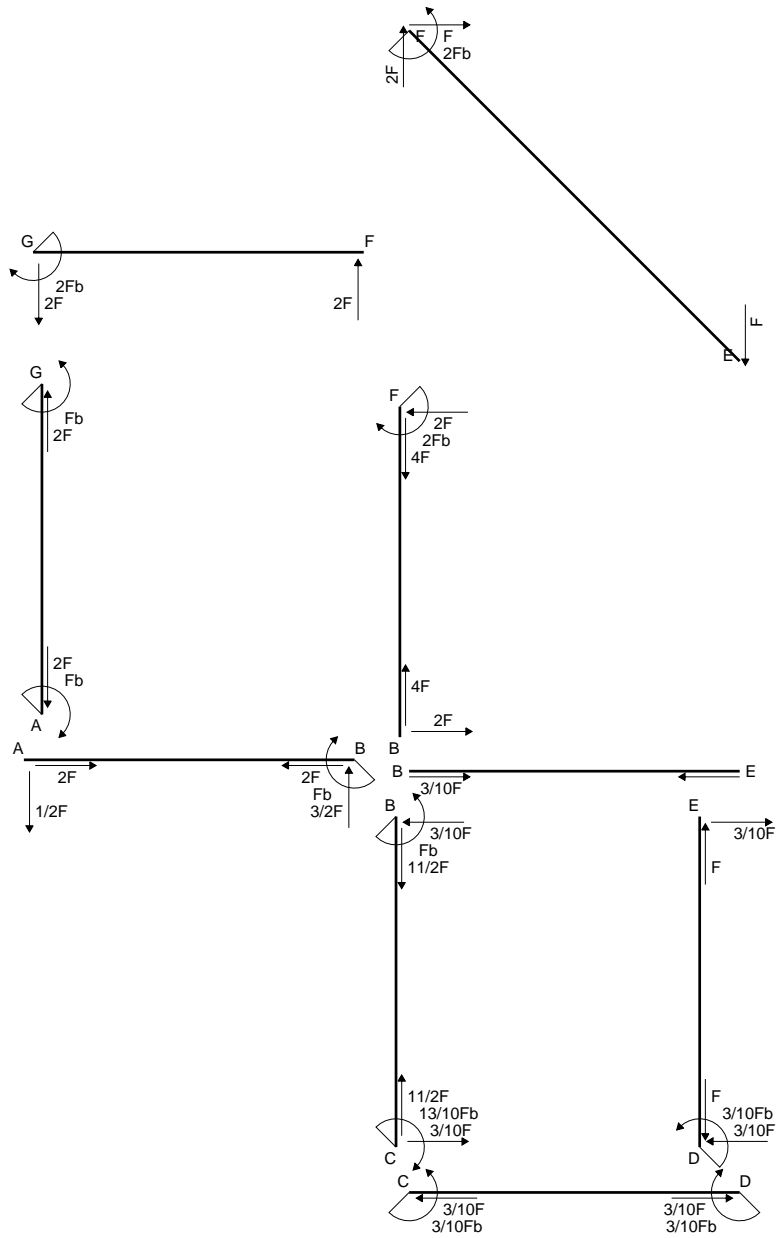

← ⊕ → F

↑ ⊕ ↓ F

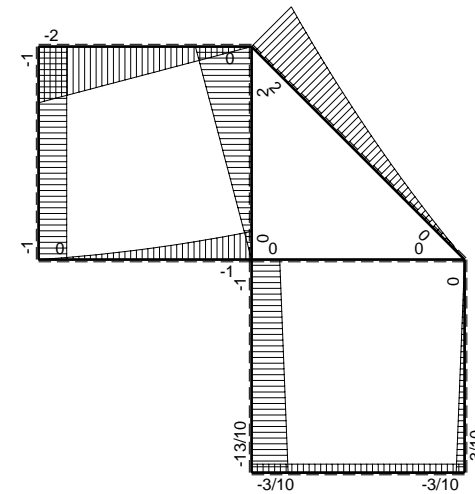

⊕ ⊖ F_b

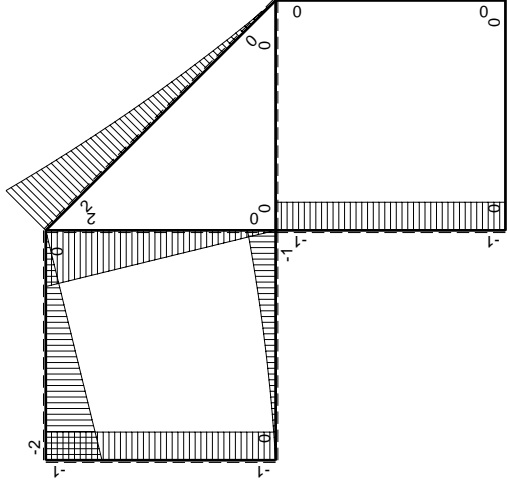
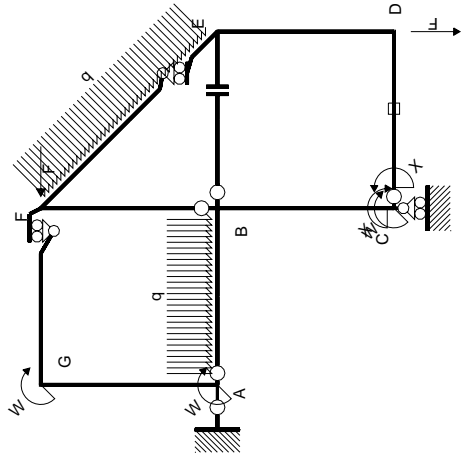

Schema di calcolo iperstatico

M_0 flessione da carichi assegnati

Quadro contribuiti PLV per iperstatica $X=W_{cd}$

\rightarrow	$M_x(x)$	$M_0(x)$	$M_x M_0$	$M_x M_x$	$\int M_x M_0 / E J dx$	$\int X M_x M_x / E J dx$
AB b	0	$-1/2Fx - 1/2qx^2$	0	0	0	0
BA b	0	$Fb - 3/2Fx + 1/2qx^2$	0	0	0	0
BC b	$-x/b$	$-Fb$	Fx	x^2/b^2	$1/2Fb^2/EJ$	$1/3Xb/EJ$
CB b	$1-x/b$	Fb	$Fb-Fx$	$1-2x/b+x^2/b^2$		
CD b	-1	0	0	1	0	Xb/EJ
DC b	1	0	0	1	0	
DE b	$-1+x/b$	0	0	$1-2x/b+x^2/b^2$	0	$1/3Xb/EJ$
ED b	x/b	0	0	x^2/b^2	0	0
EF $\sqrt{2}b$	0	$\sqrt{2}/2Fx + 1/2qx^2$	0	0	0	0
FG b	0	$-2Fx$	0	0	0	0
GF b	0	$2Fb-2Fx$	0	0	0	0
GA b	0	$-Fb$	0	0	0	0
AG b	0	Fb	0	0	0	0
FB b	0	$2Fb-2Fx$	0	0	0	0
BF b	0	$-2Fx$	0	0	0	0
BE b	0	0	0	0	0	0
EB b	0	0	0	0	0	0
CD	elongazione asta $N_{1,cd} \epsilon_{cd} L_{cd}$				$-Fb^2/EJ$	
	totali				$-1/2Fb^2/EJ$	$5/3Xb/EJ$
	iperstatica $X=W_{cd}$				$3/10Fb$	

Sviluppi di calcolo iperstatica

M_x flessione da iperstatica $X=1$

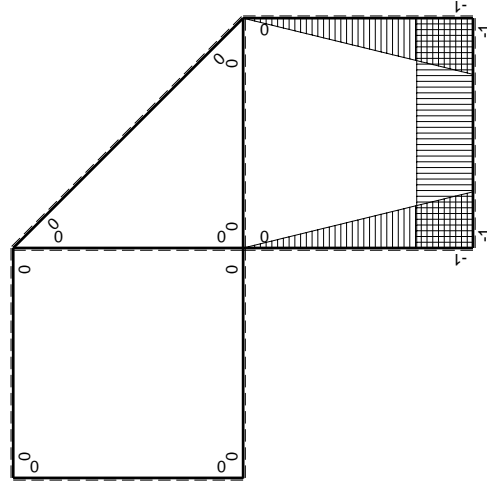

$$L_{BC}^{xx} = \int_0^b (x^2/b^2) 1/EJ dx = [1/3 x^3/b^2]_0^b 1/EJ$$

$$= (1/3 b) 1/EJ = 1/3 b/EJ$$

$$L_{CB}^{xx} = \int_0^b (1 - 2x/b + x^2/b^2) 1/EJ dx = [x - x^2/b + 1/3 x^3/b^2]_0^b 1/EJ$$

$$= (b - b + 1/3 b) 1/EJ = 1/3 b/EJ$$

$$L_{CD}^{xx} = \int_0^b (1) 1/EJ dx = [x]_0^b 1/EJ$$

$$= (b) 1/EJ = b/EJ$$

$$L_{DC}^{xx} = \int_0^b (1) 1/EJ dx = [x]_0^b 1/EJ$$

$$= (b) 1/EJ = b/EJ$$

$$L_{DE}^{xx} = \int_0^b (1 - 2x/b + x^2/b^2) 1/EJ dx = [x - x^2/b + 1/3 x^3/b^2]_0^b 1/EJ$$

$$= (b - b + 1/3 b) 1/EJ = 1/3 b/EJ$$

$$L_{ED}^{xx} = \int_0^b (x^2/b^2) 1/EJ dx = [1/3 x^3/b^2]_0^b 1/EJ$$

$$= (1/3 b) 1/EJ = 1/3 b/EJ$$

$$L_{BC}^{xo} = \int_0^b (x/b) Fb 1/EJ dx = [1/2 x^2/b]_0^b Fb 1/EJ$$

$$= (1/2 b) Fb 1/EJ = 1/2 Fb^2/EJ$$

$$L_{CB}^{xo} = \int_0^b (1 - x/b) Fb 1/EJ dx = [x - 1/2 x^2/b]_0^b Fb 1/EJ$$

$$= (b - 1/2 b) Fb 1/EJ = 1/2 Fb^2/EJ$$

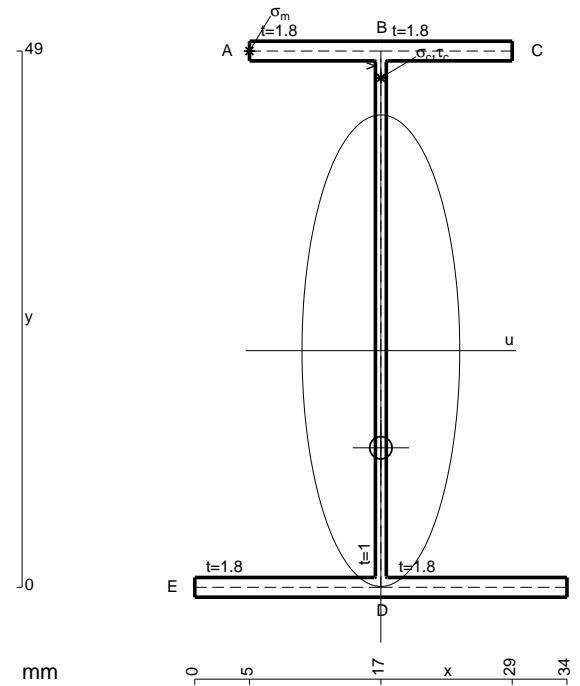

- A = 153.4 mm²
- J_u = 71202. mm⁴
- J_v = 7969. mm⁴
- J_I = 129.1 mm⁴
- y_o = -8.875 mm
- y_g = 21.63 mm
- N = 254.6 N
- T_y = 763.7 N
- M_x = 626400. Nmm
- x_m = 5. mm
- y_m = 49. mm
- u_m = -12. mm
- v_m = 27.37 mm
- σ_m = N/A-Mv/J_u = -239.2 N/mm²
- x_c = 17. mm
- y_c = 49. mm
- v_c = 27.37 mm
- σ_c = N/A-Mv/J_u = -239.2 N/mm²
- τ_c = TS/tJ_u = 12.68 N/mm²
- τ_g = TS/tJ_u = 12.68 N/mm²
- t_c = 360. mm
- σ_o = √σ²+3τ² = 240.2 N/mm²

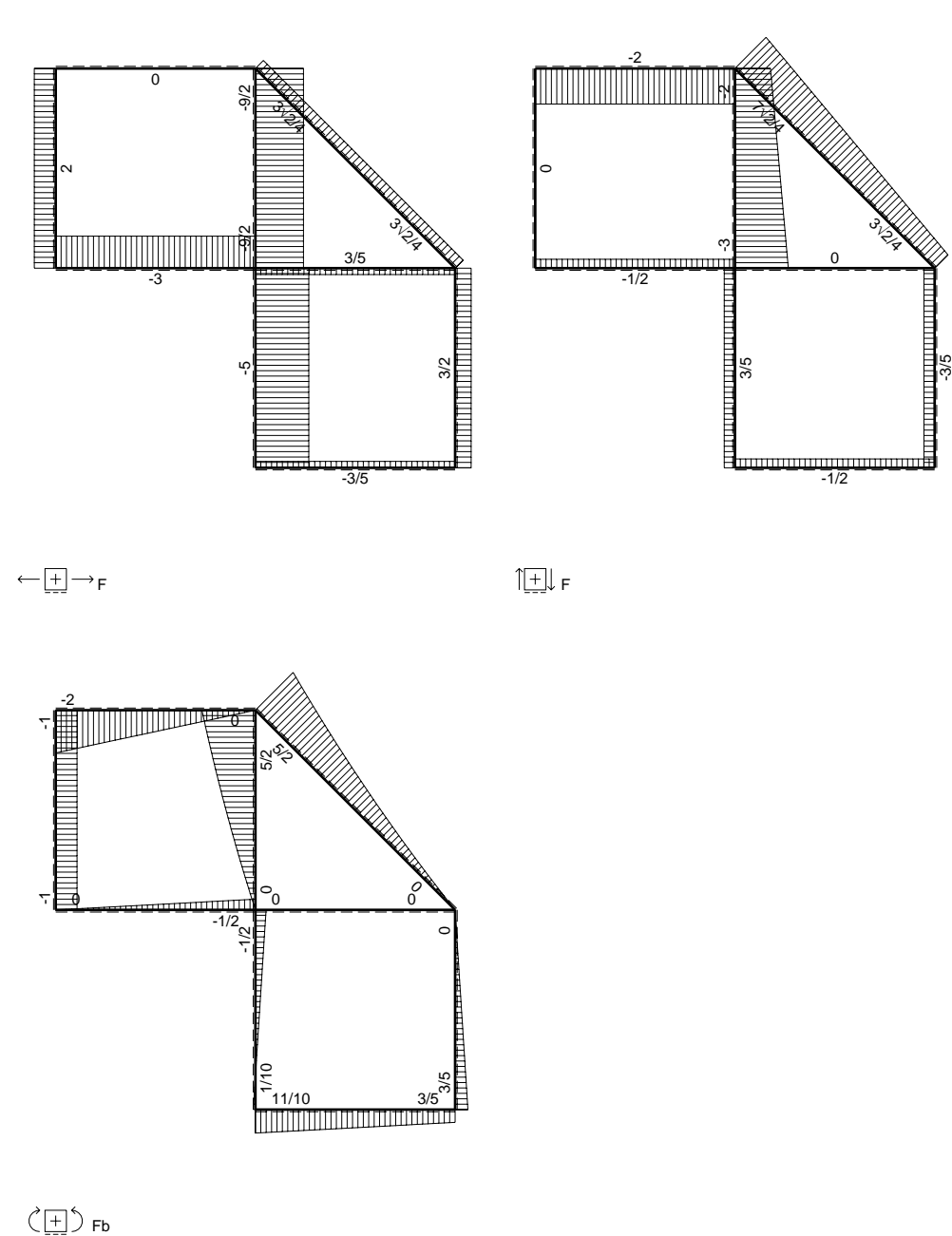
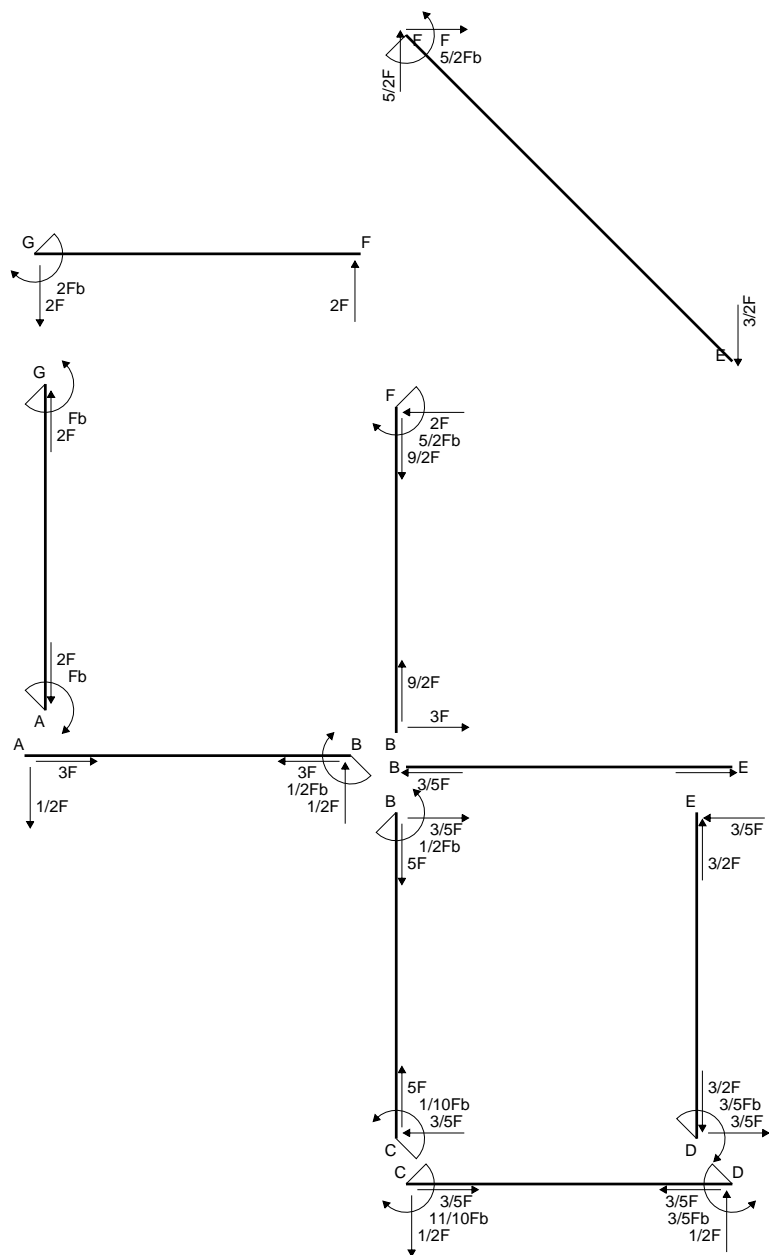

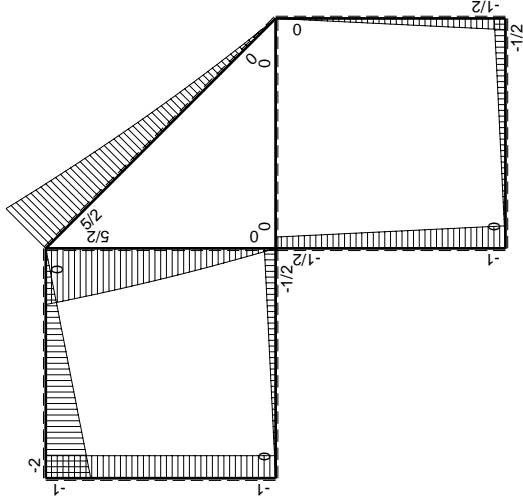
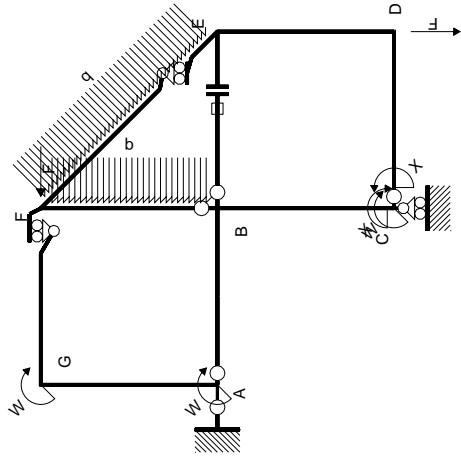

Schema di calcolo iperstatico

M_0 flessione da carichi assegnati

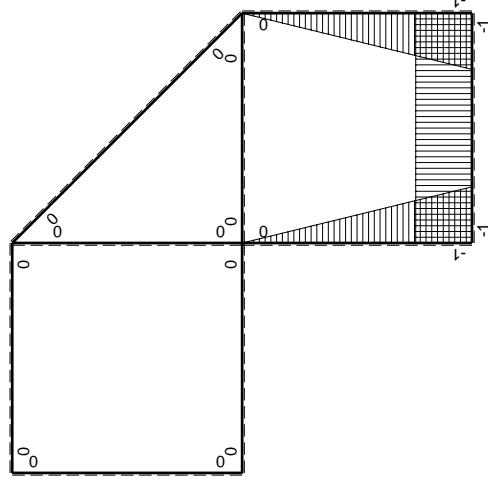

M_x flessione da iperstatica X=1

Quadro contribuiti PLV per iperstatica X=W_{cd}

→	$M_x(x)$	$M_0(x)$	$M_x M_0$	$M_x M_x$	$\int M_x M_0 / E J dx$	$\int M_x M_x / E J dx$
AB b	0	-1/2Fx	0	0	0	0
BA b	0	1/2Fb-1/2Fx	0	0	0	0
BC b	-x/b	-1/2Fb-1/2Fx	1/2Fx+1/2Fx ² /b	x ² /b ²	5/12Fb ² /EJ	1/3Xb/EJ
CB b	1-x/b	Fb-1/2Fx	Fb-3/2Fx+1/2Fx ² /b	1-2x/b+x ² /b ²	1/4Fb ² /EJ	Xb/EJ
CD b	-1	-1/2Fx	1/2Fx	1	1/4Fb ² /EJ	Xb/EJ
DC b	1	1/2Fb-1/2Fx	1/2Fb-1/2Fx	1	1/4Fb ² /EJ	Xb/EJ
DE b	-1+x/b	-1/2Fb+1/2Fx	1/2Fb-Fx+1/2Fx ² /b	1-2x/b+x ² /b ²	1/6Fb ² /EJ	1/3Xb/EJ
ED b	x/b	1/2Fx	1/2Fx ² /b	x ² /b ²	1/6Fb ² /EJ	1/3Xb/EJ
EF √2b	0	3√2/4Fx+1/2qx ²	0	0	0	0
FG b	0	-2Fx	0	0	0	0
GF b	0	2Fb-2Fx	0	0	0	0
GA b	0	-Fb	0	0	0	0
AG b	0	Fb	0	0	0	0
FB b	0	5/2Fb-2Fx-1/2qx ²	0	0	0	0
BF b	0	-3Fx+1/2qx ²	0	0	0	0
BE b	0	0	0	0	0	0
EB b	0	0	0	0	0	0
BE	elongazione asta $N_{1, BE} \epsilon_{BE} L_{BE}$				Fb ² /EJ	
	totali				11/6Fb ² /EJ	5/3Xb/EJ
	iperstatica X=W _{cd}				-11/10Fb	

Sviluppi di calcolo iperstatica

$$L_{BC}^{xx} = \int_0^b (x^2/b^2) 1/EJ dx = [1/3 x^3/b^2]_0^b 1/EJ$$

$$= (1/3 b) 1/EJ = 1/3 b/EJ$$

$$L_{CB}^{xx} = \int_0^b (1 - 2x/b + x^2/b^2) 1/EJ dx = [x - x^2/b + 1/3 x^3/b^2]_0^b 1/EJ$$

$$= (b - b + 1/3 b) 1/EJ = 1/3 b/EJ$$

$$L_{CD}^{xx} = \int_0^b (1) 1/EJ dx = [x]_0^b 1/EJ$$

$$= (b) 1/EJ = b/EJ$$

$$L_{DC}^{xx} = \int_0^b (1) 1/EJ dx = [x]_0^b 1/EJ$$

$$= (b) 1/EJ = b/EJ$$

$$L_{DE}^{xx} = \int_0^b (1 - 2x/b + x^2/b^2) 1/EJ dx = [x - x^2/b + 1/3 x^3/b^2]_0^b 1/EJ$$

$$= (b - b + 1/3 b) 1/EJ = 1/3 b/EJ$$

$$L_{ED}^{xx} = \int_0^b (x^2/b^2) 1/EJ dx = [1/3 x^3/b^2]_0^b 1/EJ$$

$$= (1/3 b) 1/EJ = 1/3 b/EJ$$

$$L_{BC}^{xo} = \int_0^b (1/2 x/b + 1/2 x^2/b^2) Fb 1/EJ dx = [1/4 x^2/b + 1/6 x^3/b^2]_0^b Fb 1/EJ$$

$$= (1/4 b + 1/6 b) Fb 1/EJ = 5/12 Fb^2/EJ$$

$$L_{CB}^{xo} = \int_0^b (1 - 3/2 x/b + 1/2 x^2/b^2) Fb 1/EJ dx = [x - 3/4 x^2/b + 1/6 x^3/b^2]_0^b Fb 1/EJ$$

$$= (b - 3/4 b + 1/6 b) Fb 1/EJ = 5/12 Fb^2/EJ$$

$$L_{CD}^{xo} = \int_0^b (1/2 x/b) Fb 1/EJ dx = [1/4 x^2/b]_0^b Fb 1/EJ$$

$$= (1/4 b) Fb 1/EJ = 1/4 Fb^2/EJ$$

$$L_{DC}^{xo} = \int_0^b (1/2 - 1/2 x/b) Fb 1/EJ dx = [1/2 x - 1/4 x^2/b]_0^b Fb 1/EJ$$

$$= (1/2 b - 1/4 b) Fb 1/EJ = 1/4 Fb^2/EJ$$

$$L_{DE}^{xo} = \int_0^b (1/2 - x/b + 1/2 x^2/b^2) Fb 1/EJ dx = [1/2 x - 1/2 x^2/b + 1/6 x^3/b^2]_0^b Fb 1/EJ$$

$$= (1/2 b - 1/2 b + 1/6 b) Fb 1/EJ = 1/6 Fb^2/EJ$$

$$L_{ED}^{xo} = \int_0^b (1/2 x^2/b^2) Fb 1/EJ dx = [1/6 x^3/b^2]_0^b Fb 1/EJ$$

$$= (1/6 b) Fb 1/EJ = 1/6 Fb^2/EJ$$

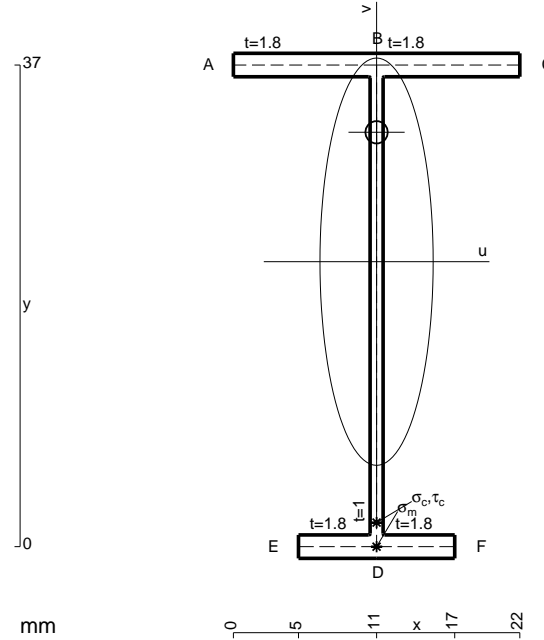

- A = 98.2 mm²
- J_u = 24038. mm⁴
- J_v = 1856. mm⁴
- J_t = 78.43 mm⁴
- y_o = 9.943 mm
- y_g = 21.89 mm
- N = 254.6 N
- T_y = 594. N
- M_x = 210000. Nmm
- x_m = 11. mm
- v_m = -21.89 mm
- σ_m = N/A-Mv/J_u = 193.8 N/mm²
- y_c = 3. mm
- u_c = -11. mm
- v_c = -18.89 mm
- σ_c = N/A-Mv/J_u = 193.8 N/mm²
- τ_c = TS_t/tJ_u = 11.68 N/mm²
- τ_g = TS_t/tJ_u = 11.68 N/mm²
- t_c = 240. mm
- σ_o = √σ²+3τ² = 194.9 N/mm²

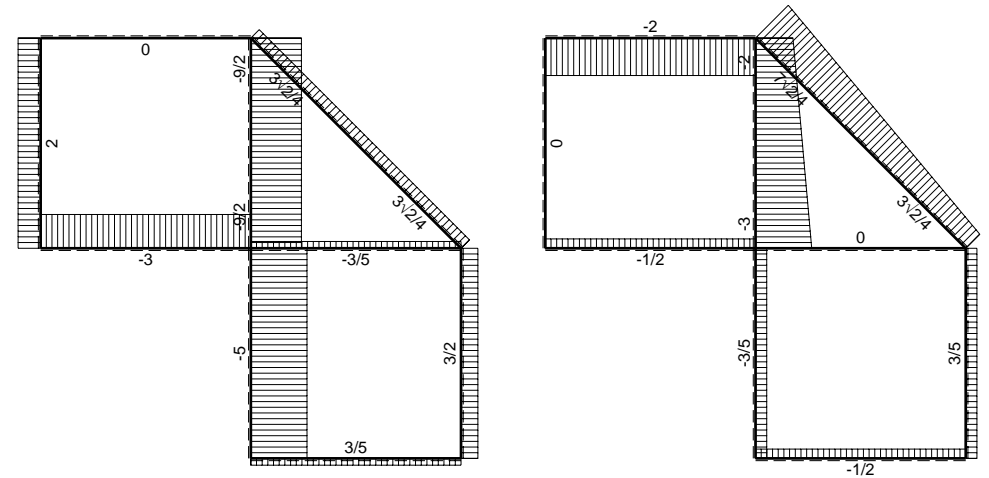
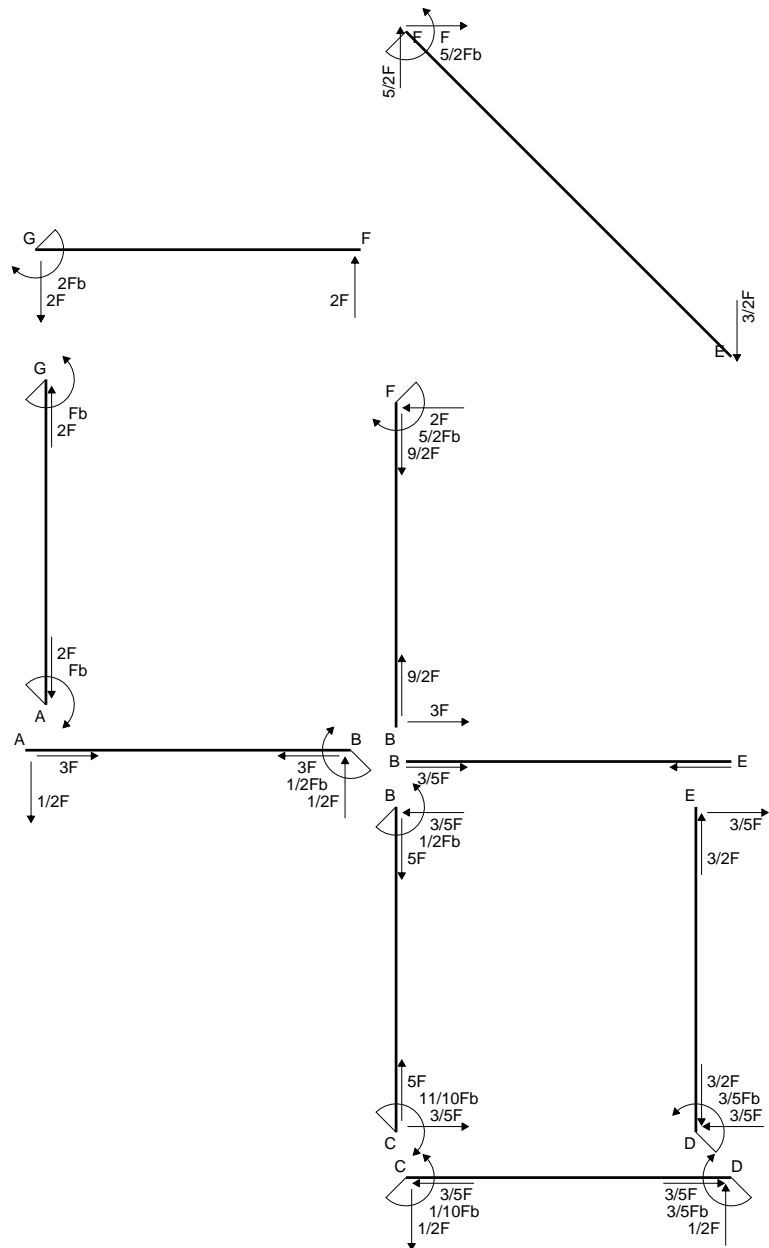

← ⊕ → F

↑ ⊕ ↓ F

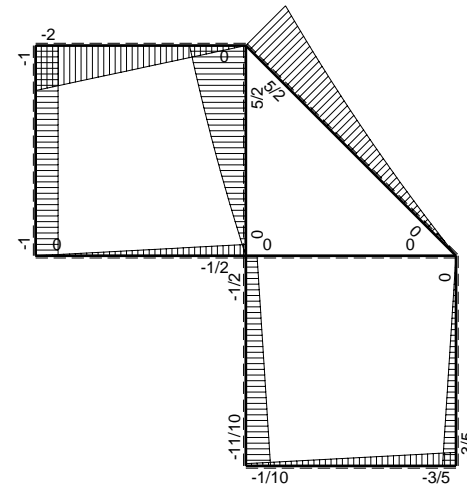

⊕ ⊖ F_b

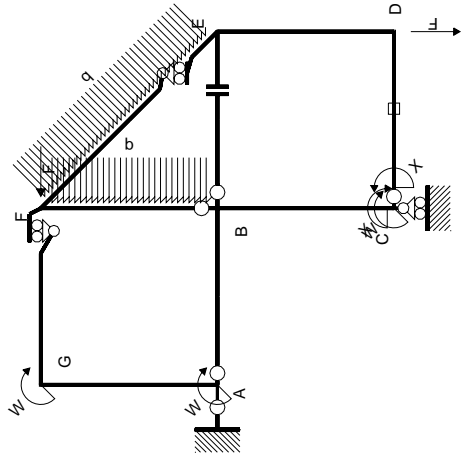

Schema di calcolo iperstatico

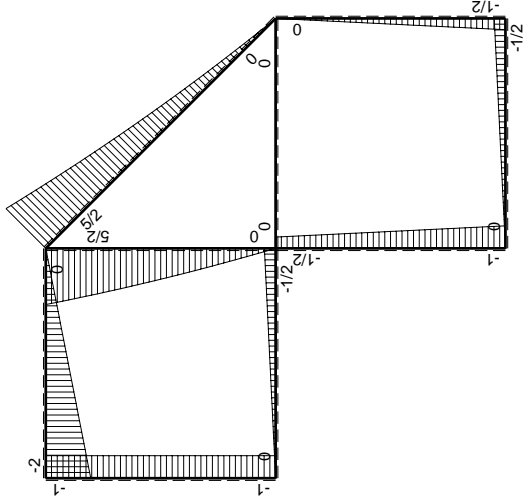

M_0 flessione da carichi assegnati

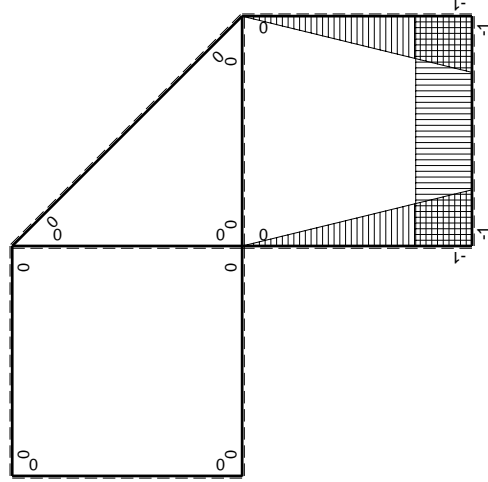

M_x flessione da iperstatica $X=1$

Quadro contribuiti PLV per iperstatica $X=W_{cd}$

\rightarrow	$M_x(x)$	$M_0(x)$	$M_x M_0$	$M_x M_x$	$\int M_x M_0 / EJ dx$	$\int X M_x M_x / EJ dx$
AB b	0	$-1/2Fx$	0	0	0	0
BA b	0	$1/2Fb-1/2Fx$	0	0	0	0
BC b	$-x/b$	$-1/2Fb-1/2Fx$	$1/2Fx+1/2Fx^2/b$	x^2/b^2	$5/12Fb^2/EJ$	$1/3Xb/EJ$
CB b	$1-x/b$	$Fb-1/2Fx$	$Fb-3/2Fx+1/2Fx^2/b$	$1-2x/b+x^2/b^2$	$1/4Fb^2/EJ$	Xb/EJ
CD b	-1	$-1/2Fx$	$1/2Fx$	1	$1/4Fb^2/EJ$	Xb/EJ
DC b	1	$1/2Fb-1/2Fx$	$1/2Fb-1/2Fx$	1	$1/4Fb^2/EJ$	Xb/EJ
DE b	$-1+x/b$	$-1/2Fb+1/2Fx$	$1/2Fb-Fx+1/2Fx^2/b$	$1-2x/b+x^2/b^2$	$1/6Fb^2/EJ$	$1/3Xb/EJ$
ED b	x/b	$1/2Fx$	$1/2Fx^2/b$	x^2/b^2	$1/6Fb^2/EJ$	$1/3Xb/EJ$
EF $\sqrt{2}b$	0	$3\sqrt{2}4Fx+1/2qx^2$	0	0	0	0
FG b	0	$-2Fx$	0	0	0	0
GF b	0	$2Fb-2Fx$	0	0	0	0
GA b	0	$-Fb$	0	0	0	0
AG b	0	Fb	0	0	0	0
FB b	0	$5/2Fb-2Fx-1/2qx^2$	0	0	0	0
BF b	0	$-3Fx+1/2qx^2$	0	0	0	0
BE b	0	0	0	0	0	0
EB b	0	0	0	0	0	0
CD	elongazione asta $N_{1,cd} \epsilon_{cd} L_{cd}$				$-Fb^2/EJ$	
	totali				$-1/6Fb^2/EJ$	$5/3Xb/EJ$
	iperstatica $X=W_{cd}$				$1/10Fb$	

Sviluppi di calcolo iperstatica

$$L_{BC}^{xx} = \int_0^b (x^2/b^2) 1/EJ dx = [1/3 x^3/b^2]_0^b 1/EJ$$

$$= (1/3 b) 1/EJ = 1/3 b/EJ$$

$$L_{CB}^{xx} = \int_0^b (1 - 2x/b + x^2/b^2) 1/EJ dx = [x - x^2/b + 1/3 x^3/b^2]_0^b 1/EJ$$

$$= (b - b + 1/3 b) 1/EJ = 1/3 b/EJ$$

$$L_{CD}^{xx} = \int_0^b (1) 1/EJ dx = [x]_0^b 1/EJ$$

$$= (b) 1/EJ = b/EJ$$

$$L_{DC}^{xx} = \int_0^b (1) 1/EJ dx = [x]_0^b 1/EJ$$

$$= (b) 1/EJ = b/EJ$$

$$L_{DE}^{xx} = \int_0^b (1 - 2x/b + x^2/b^2) 1/EJ dx = [x - x^2/b + 1/3 x^3/b^2]_0^b 1/EJ$$

$$= (b - b + 1/3 b) 1/EJ = 1/3 b/EJ$$

$$L_{ED}^{xx} = \int_0^b (x^2/b^2) 1/EJ dx = [1/3 x^3/b^2]_0^b 1/EJ$$

$$= (1/3 b) 1/EJ = 1/3 b/EJ$$

$$L_{BC}^{x_0} = \int_0^b (1/2 x/b + 1/2 x^2/b^2) Fb 1/EJ dx = [1/4 x^2/b + 1/6 x^3/b^2]_0^b Fb 1/EJ$$

$$= (1/4 b + 1/6 b) Fb 1/EJ = 5/12 Fb^2/EJ$$

$$L_{CB}^{x_0} = \int_0^b (1 - 3/2 x/b + 1/2 x^2/b^2) Fb 1/EJ dx = [x - 3/4 x^2/b + 1/6 x^3/b^2]_0^b Fb 1/EJ$$

$$= (b - 3/4 b + 1/6 b) Fb 1/EJ = 5/12 Fb^2/EJ$$

$$L_{CD}^{x_0} = \int_0^b (1/2 x/b) Fb 1/EJ dx + 1 (-1) 1 Fb^2/EJ = [1/4 x^2/b]_0^b Fb 1/EJ + 1 (-1) 1 Fb^2/EJ$$

$$= (1/4 b) Fb 1/EJ + 1 (-1) 1 Fb^2/EJ = -3/4 Fb^2/EJ$$

$$L_{DC}^{x_0} = \int_0^b (1/2 - 1/2 x/b) Fb 1/EJ dx + 1 (-1) 1 Fb^2/EJ = [1/2 x - 1/4 x^2/b]_0^b Fb 1/EJ + 1 (-1) 1 Fb^2/EJ$$

$$= (1/2 b - 1/4 b) Fb 1/EJ + 1 (-1) 1 Fb^2/EJ = -3/4 Fb^2/EJ$$

$$L_{DE}^{x_0} = \int_0^b (1/2 - x/b + 1/2 x^2/b^2) Fb 1/EJ dx = [1/2 x - 1/2 x^2/b + 1/6 x^3/b^2]_0^b Fb 1/EJ$$

$$= (1/2 b - 1/2 b + 1/6 b) Fb 1/EJ = 1/6 Fb^2/EJ$$

$$L_{ED}^{x_0} = \int_0^b (1/2 x^2/b^2) Fb 1/EJ dx = [1/6 x^3/b^2]_0^b Fb 1/EJ$$

$$= (1/6 b) Fb 1/EJ = 1/6 Fb^2/EJ$$

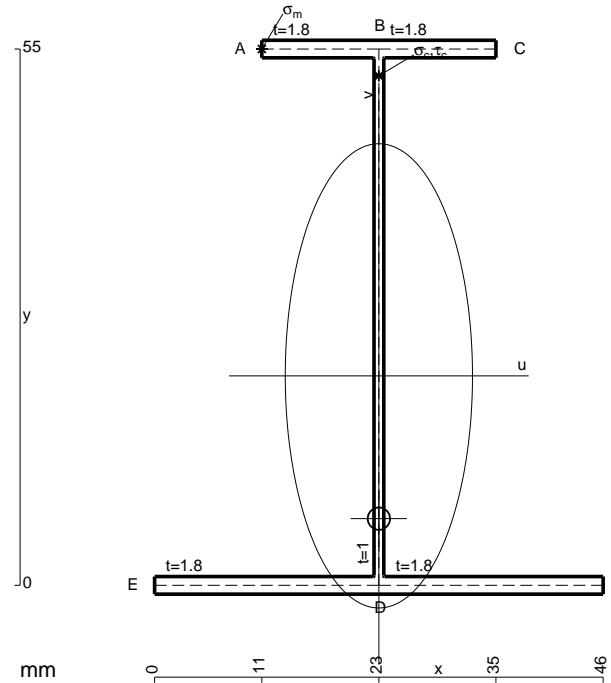

- A = 181. mm²
- J_u = 102600. mm⁴
- J_v = 16674. mm⁴
- J_i = 154.4 mm⁴
- y_o = -14.64 mm
- y_g = 21.48 mm
- N = 477.3 N
- T_y = 1114. N
- M_x = 641250. Nmm
- x_m = 11. mm
- y_m = 55. mm
- u_m = -12. mm
- v_m = 33.52 mm
- σ_m = N/A - M_v/J_u = -206.8 N/mm²
- x_c = 23. mm
- y_c = 55. mm
- v_c = 33.52 mm
- σ_c = N/A - M_v/J_u = -206.8 N/mm²
- τ_c = T_S/t_{J_u} = 15.72 N/mm²
- τ_g = T_S/t_{J_u} = 15.72 N/mm²
- t_c = 450. mm
- σ_o = √σ² + 3τ² = 208.6 N/mm²

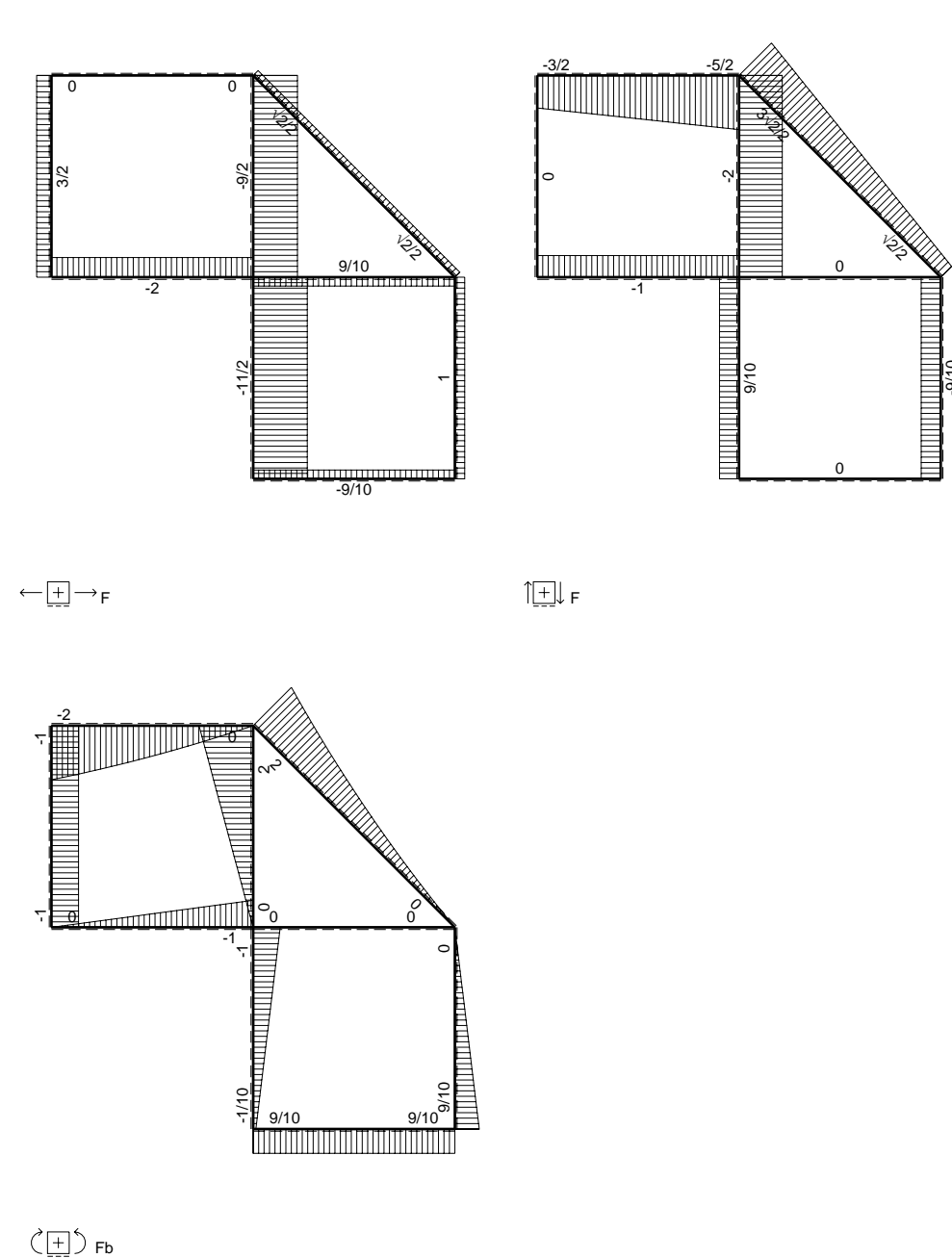
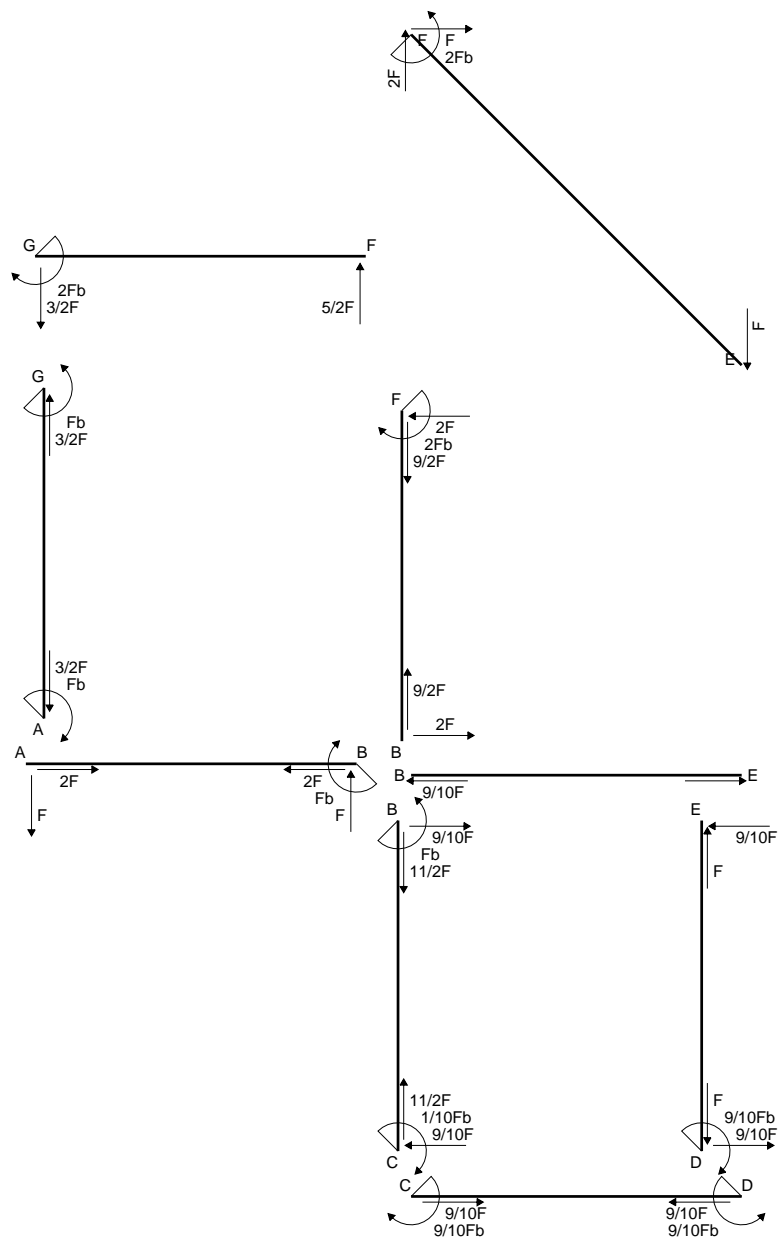

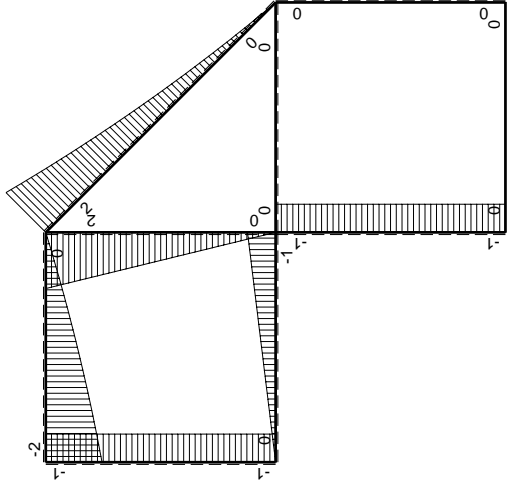
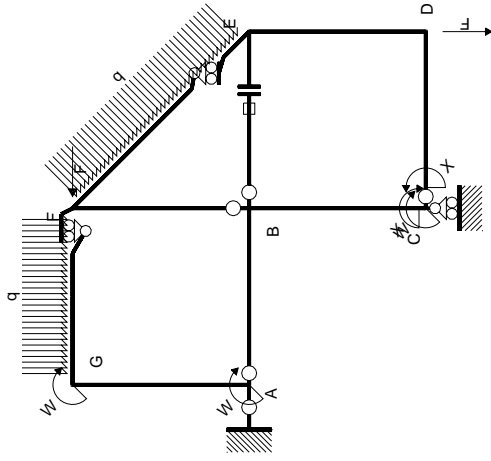

Schema di calcolo iperstatico

M_0 flessione da carichi assegnati

M_x flessione da iperstatica $X=1$

Quadro contribuiti PLV per iperstatica $X=W_{cd}$

\rightarrow	$M_x(x)$	$M_0(x)$	$M_x M_0$	$M_x M_x$	$\int M_x M_0 / EJ dx$	$\int M_x M_x / EJ dx$
AB b	0	-Fx	0	0	0	0
BA b	0	Fb-Fx	0	0	0	0
BC b	-x/b	-Fb	Fx	x^2/b^2	$1/2 Fb^2/EJ$	$1/3 Xb/EJ$
CB b	1-x/b	Fb	Fb-Fx	$1-2x/b+x^2/b^2$		
CD b	-1	0	0	1	0	Xb/EJ
DC b	1	0	0	1	0	
DE b	-1+x/b	0	0	$1-2x/b+x^2/b^2$	0	$1/3 Xb/EJ$
ED b	x/b	0	0	x^2/b^2	0	0
EF $\sqrt{2}b$	0	$\sqrt{2}/2 Fx + 1/2 qx^2$	0	0	0	0
FG b	0	$-5/2 Fx + 1/2 qx^2$	0	0	0	0
GF b	0	$2Fb - 3/2 Fx - 1/2 qx^2$	0	0	0	0
GA b	0	-Fb	0	0	0	0
AG b	0	Fb	0	0	0	0
FB b	0	$2Fb - 2Fx$	0	0	0	0
BF b	0	-2Fx	0	0	0	0
BE b	0	0	0	0	0	0
EB b	0	0	0	0	0	0
BE	elongazione asta $N_{1, BE} \epsilon_{BE} L_{BE}$				Fb^2/EJ	
	totali				$3/2 Fb^2/EJ$	$5/3 Xb/EJ$
	iperstatica $X=W_{cd}$				$-9/10 Fb$	

Sviluppi di calcolo iperstatica

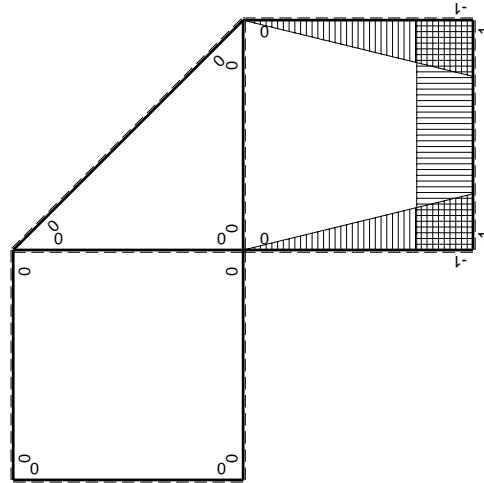

$$L_{BC}^{xx} = \int_0^b (x^2/b^2) 1/EJ dx = [1/3 x^3/b^2]_0^b 1/EJ$$

$$= (1/3 b) 1/EJ = 1/3 b/EJ$$

$$L_{CB}^{xx} = \int_0^b (1 - 2x/b + x^2/b^2) 1/EJ dx = [x - x^2/b + 1/3 x^3/b^2]_0^b 1/EJ$$

$$= (b - b + 1/3 b) 1/EJ = 1/3 b/EJ$$

$$L_{CD}^{xx} = \int_0^b (1) 1/EJ dx = [x]_0^b 1/EJ$$

$$= (b) 1/EJ = b/EJ$$

$$L_{DC}^{xx} = \int_0^b (1) 1/EJ dx = [x]_0^b 1/EJ$$

$$= (b) 1/EJ = b/EJ$$

$$L_{DE}^{xx} = \int_0^b (1 - 2x/b + x^2/b^2) 1/EJ dx = [x - x^2/b + 1/3 x^3/b^2]_0^b 1/EJ$$

$$= (b - b + 1/3 b) 1/EJ = 1/3 b/EJ$$

$$L_{ED}^{xx} = \int_0^b (x^2/b^2) 1/EJ dx = [1/3 x^3/b^2]_0^b 1/EJ$$

$$= (1/3 b) 1/EJ = 1/3 b/EJ$$

$$L_{BC}^{xo} = \int_0^b (x/b) Fb 1/EJ dx = [1/2 x^2/b]_0^b Fb 1/EJ$$

$$= (1/2 b) Fb 1/EJ = 1/2 Fb^2/EJ$$

$$L_{CB}^{xo} = \int_0^b (1 - x/b) Fb 1/EJ dx = [x - 1/2 x^2/b]_0^b Fb 1/EJ$$

$$= (b - 1/2 b) Fb 1/EJ = 1/2 Fb^2/EJ$$

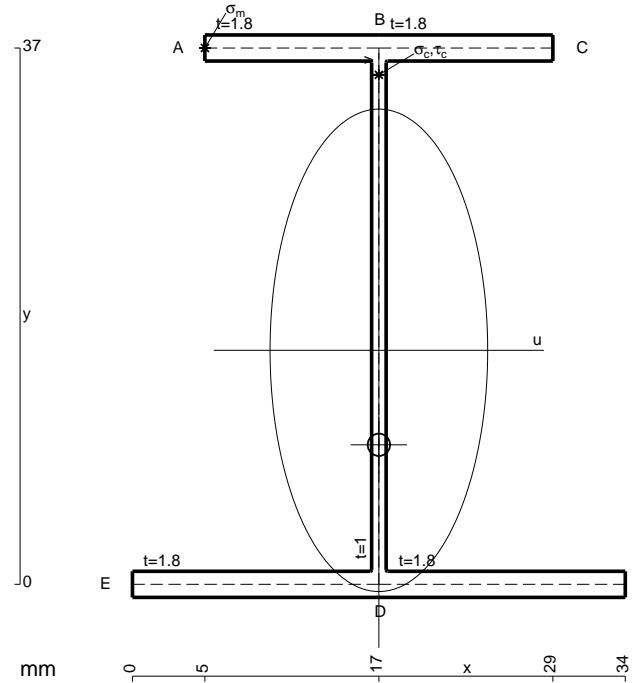

- A = 141.4 mm²
- J_u = 39168. mm⁴
- J_v = 7969. mm⁴
- J_I = 125.1 mm⁴
- y_o = -6.518 mm
- y_g = 16.15 mm
- N = -2025. N
- T_y = -900. N
- M_x = 378000. Nmm
- x_m = 5. mm
- y_m = 37. mm
- u_m = -12. mm
- v_m = 20.85 mm
- σ_m = N/A-Mv/J_u = -215.6 N/mm²
- x_c = 17. mm
- y_c = 37. mm
- v_c = 20.85 mm
- σ_c = N/A-Mv/J_u = -215.6 N/mm²
- τ_c = TS/tJ_u = 20.7 N/mm²
- τ_g = TS/tJ_u = 20.7 N/mm²
- t_c = 450. mm
- σ_o = √σ²+3τ² = 218.6 N/mm²

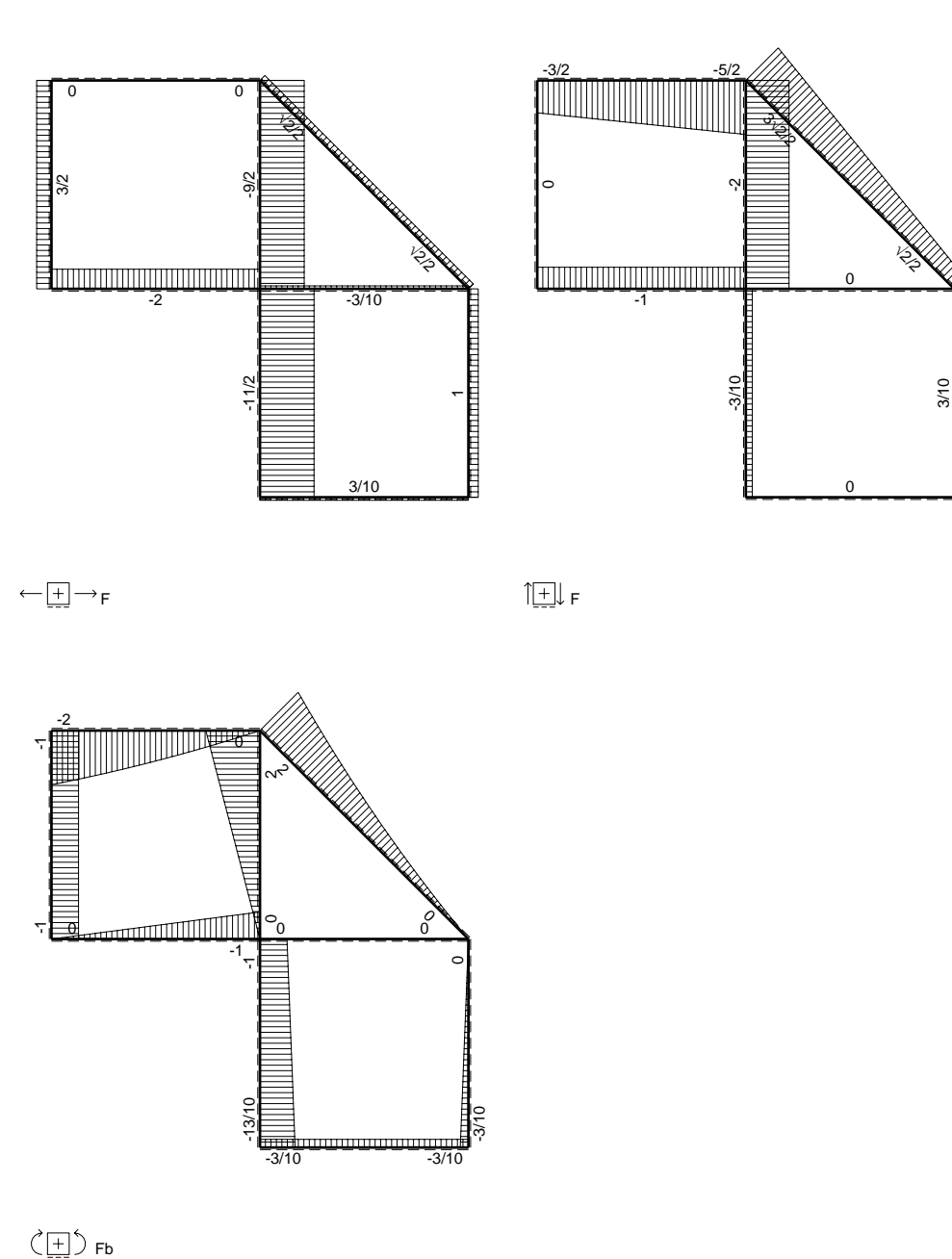
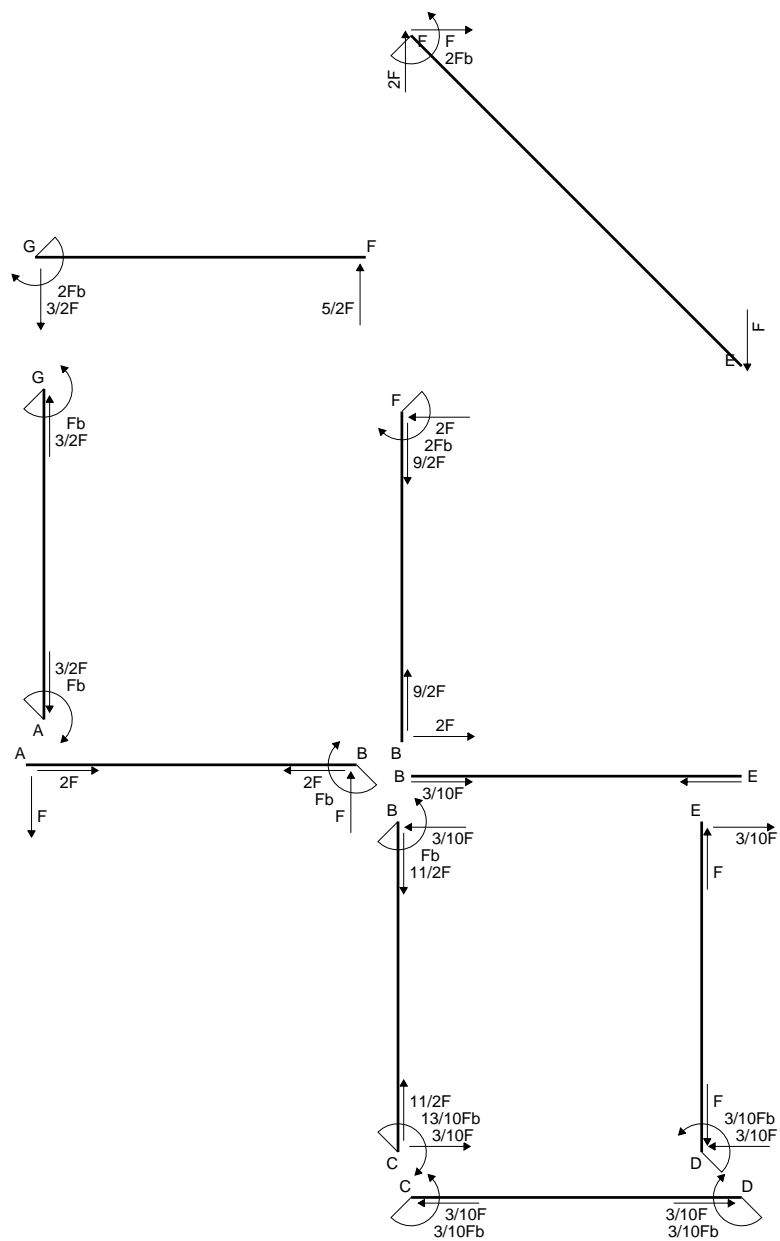

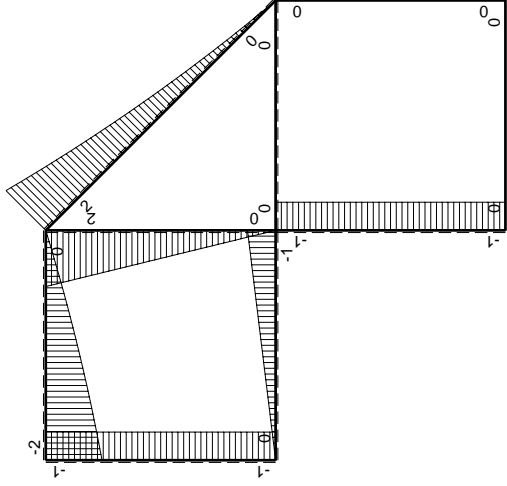
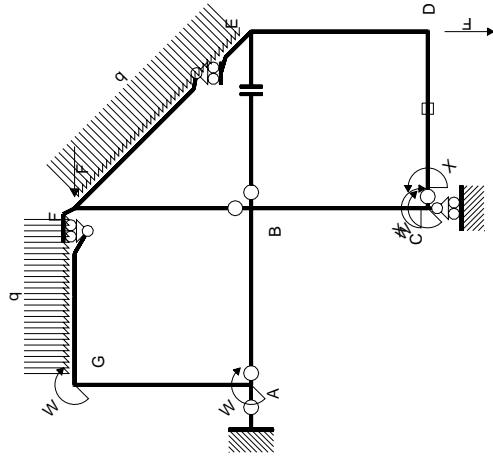

Schema di calcolo iperstatico

M_0 flessione da carichi assegnati

M_x flessione da iperstatica $X=1$

Quadro contributi PLV per iperstatica $X=W_{cd}$

\rightarrow	$M_x(x)$	$M_0(x)$	$M_x M_0$	$M_x M_x$	$\int M_x M_0 / EJ dx$	$\int M_x M_x / EJ dx$
AB b	0	-Fx	0	0	0	0
BA b	0	Fb-Fx	0	0	0	0
BC b	-x/b	-Fb	Fx	x^2/b^2	$1/2 Fb^2/EJ$	$1/3 Xb/EJ$
CB b	1-x/b	Fb	Fb-Fx	$1-2x/b+x^2/b^2$		
CD b	-1	0	0	1	0	Xb/EJ
DC b	1	0	0	1	0	$1/3 Xb/EJ$
DE b	-1+x/b	0	0	$1-2x/b+x^2/b^2$	0	$1/3 Xb/EJ$
ED b	x/b	0	0	x^2/b^2	0	0
EF $\sqrt{2}b$	0	$\sqrt{2}/2 Fx + 1/2 qx^2$	0	0	0	0
FG b	0	$-5/2 Fx + 1/2 qx^2$	0	0	0	0
GF b	0	$2Fb - 3/2 Fx - 1/2 qx^2$	0	0	0	0
GA b	0	-Fb	0	0	0	0
AG b	0	Fb	0	0	0	0
FB b	0	$2Fb - 2Fx$	0	0	0	0
BF b	0	-2Fx	0	0	0	0
BE b	0	0	0	0	0	0
EB b	0	0	0	0	0	0
CD	elongazione asta $N_{1,cd} \epsilon_{cd} L_{cd}$				-Fb ² /EJ	
	totali				-1/2 Fb ² /EJ	5/3 Xb/EJ
	iperstatica $X=W_{cd}$				3/10 Fb	

Sviluppi di calcolo iperstatica

$$L_{BC}^{xx} = \int_0^b (x^2/b^2) 1/EJ dx = [1/3 x^3/b^2]_0^b 1/EJ$$

$$= (1/3 b) 1/EJ = 1/3 b/EJ$$

$$L_{CB}^{xx} = \int_0^b (1 - 2x/b + x^2/b^2) 1/EJ dx = [x - x^2/b + 1/3 x^3/b^2]_0^b 1/EJ$$

$$= (b - b + 1/3 b) 1/EJ = 1/3 b/EJ$$

$$L_{CD}^{xx} = \int_0^b (1) 1/EJ dx = [x]_0^b 1/EJ$$

$$= (b) 1/EJ = b/EJ$$

$$L_{DC}^{xx} = \int_0^b (1) 1/EJ dx = [x]_0^b 1/EJ$$

$$= (b) 1/EJ = b/EJ$$

$$L_{DE}^{xx} = \int_0^b (1 - 2x/b + x^2/b^2) 1/EJ dx = [x - x^2/b + 1/3 x^3/b^2]_0^b 1/EJ$$

$$= (b - b + 1/3 b) 1/EJ = 1/3 b/EJ$$

$$L_{ED}^{xx} = \int_0^b (x^2/b^2) 1/EJ dx = [1/3 x^3/b^2]_0^b 1/EJ$$

$$= (1/3 b) 1/EJ = 1/3 b/EJ$$

$$L_{BC}^{xo} = \int_0^b (x/b) Fb 1/EJ dx = [1/2 x^2/b]_0^b Fb 1/EJ$$

$$= (1/2 b) Fb 1/EJ = 1/2 Fb^2/EJ$$

$$L_{CB}^{xo} = \int_0^b (1 - x/b) Fb 1/EJ dx = [x - 1/2 x^2/b]_0^b Fb 1/EJ$$

$$= (b - 1/2 b) Fb 1/EJ = 1/2 Fb^2/EJ$$

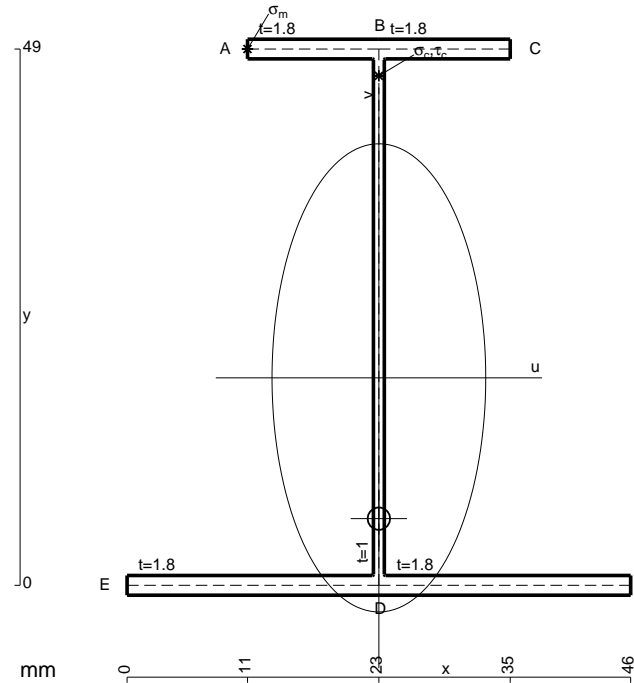

- A = 175. mm²
- J_u = 80057. mm⁴
- J_v = 16674. mm⁴
- J_I = 152.4 mm⁴
- y_o = -12.86 mm
- y_g = 18.96 mm
- N = -2205. N
- T_y = -980. N
- M_x = 578200. Nmm
- x_m = 11. mm
- y_m = 49. mm
- u_m = -12. mm
- v_m = 30.04 mm
- σ_m = N/A-Mv/J_u = -229.6 N/mm²
- x_c = 23. mm
- y_c = 49. mm
- v_c = 30.04 mm
- σ_c = N/A-Mv/J_u = -229.6 N/mm²
- τ_c = TS/tJ_u = 15.89 N/mm²
- τ_g = TS/tJ_u = 15.89 N/mm²
- t_c = 490. mm
- σ_o = √σ²+3τ² = 231.2 N/mm²

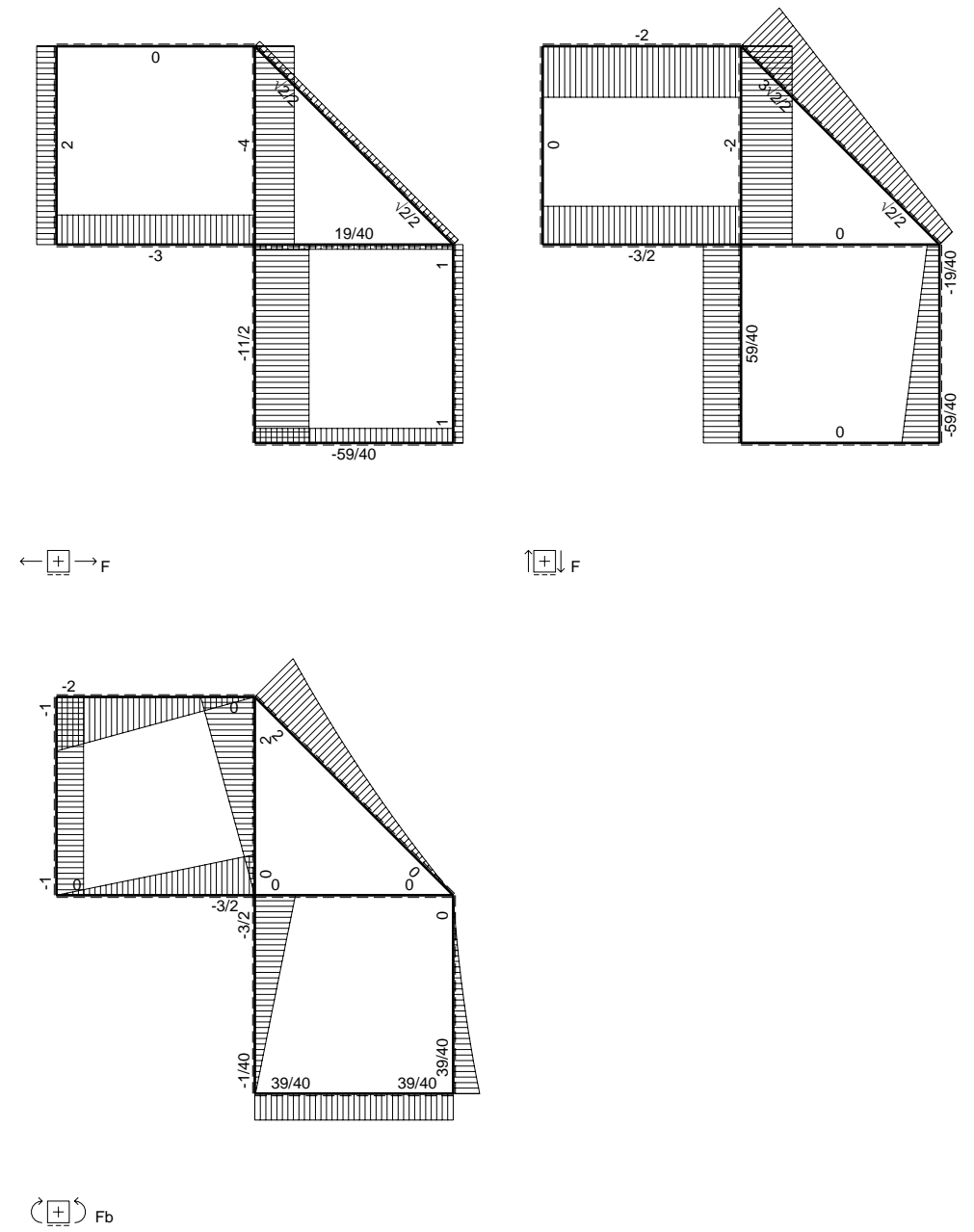
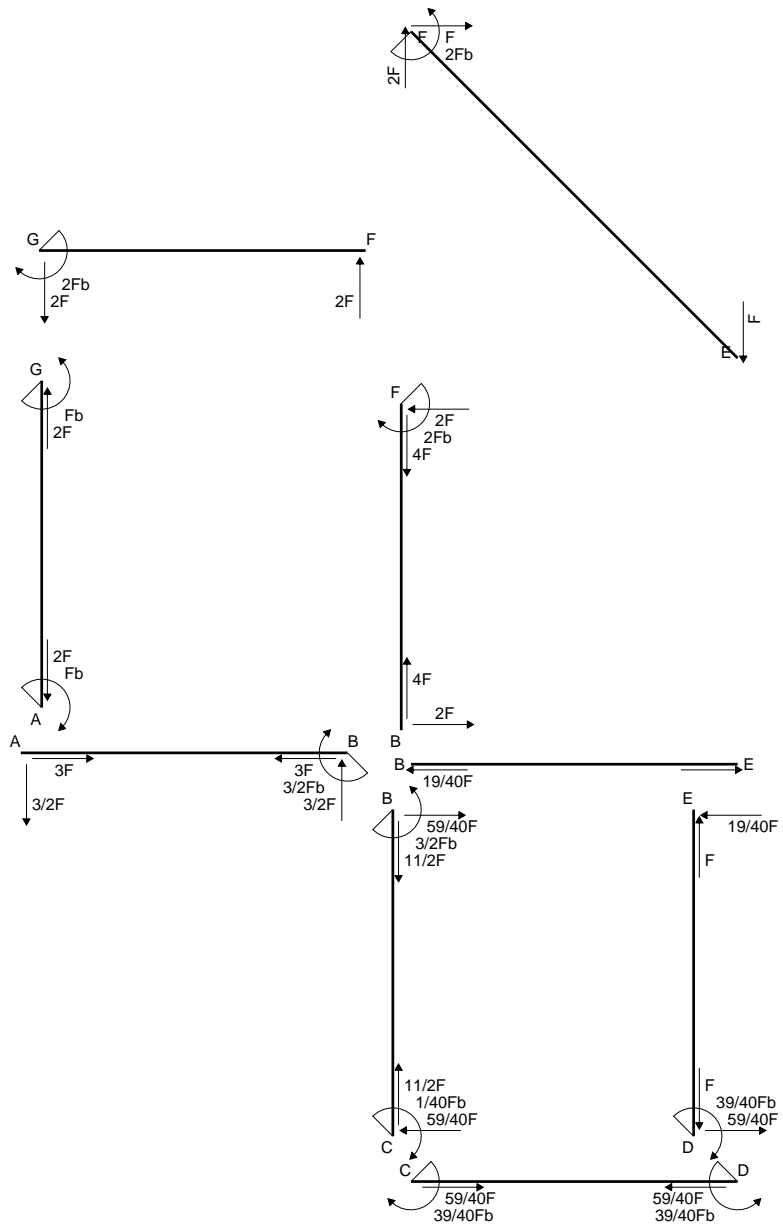

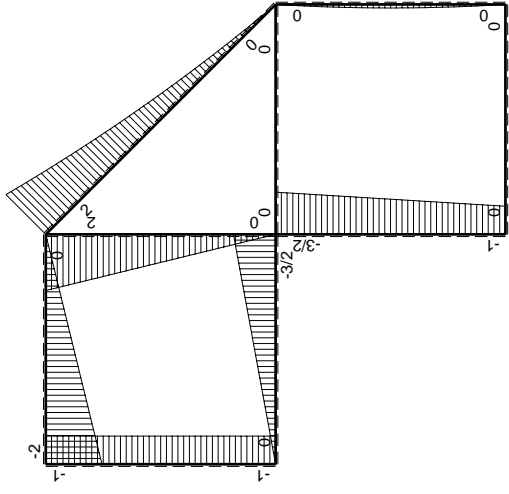
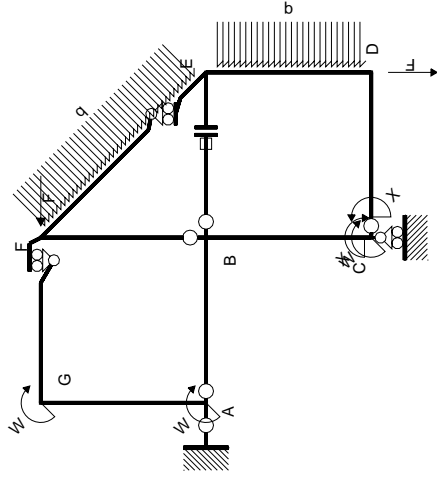

Schema di calcolo iperstatico

M_0 flessione da carichi assegnati

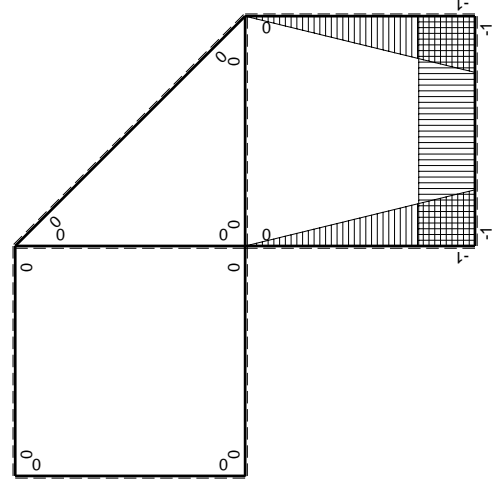

M_x flessione da iperstatica X=1

Quadro contribuiti PLV per iperstatica X=W_{cd}

→	$M_x(x)$	$M_0(x)$	$M_x M_0$	$M_x M_x$	$\int M_x M_0 / EJ dx$	$\int X M_x M_x / EJ dx$
AB b	0	-3/2Fx	0	0	0	0
BA b	0	3/2Fb-3/2Fx	0	0	0	0
BC b	-x/b	-3/2Fb+1/2Fx	3/2Fx-1/2Fx ² /b	x ² /b ²	7/12Fb ² /EJ	1/3Xb/EJ
CB b	1-x/b	Fb+1/2Fx	Fb-1/2Fx-1/2Fx ² /b	1-2x/b+x ² /b ²	0	Xb/EJ
CD b	-1	0	0	1	0	0
DC b	1	0	0	1	0	0
DE b	-1+x/b	-1/2Fx+1/2qx ²	1/2Fx-Fx ² /b+1/2qx ³ /b	1-2x/b+x ² /b ²	1/24Fb ² /EJ	1/3Xb/EJ
ED b	x/b	1/2Fx-1/2qx ²	1/2Fx ² /b-1/2qx ³ /b	x ² /b ²	0	0
EF √2b	0	√2/2Fx+1/2qx ²	0	0	0	0
FG b	0	-2Fx	0	0	0	0
GF b	0	2Fb-2Fx	0	0	0	0
GA b	0	-Fb	0	0	0	0
AG b	0	Fb	0	0	0	0
FB b	0	2Fb-2Fx	0	0	0	0
BF b	0	-2Fx	0	0	0	0
BE b	0	0	0	0	0	0
EB b	0	0	0	0	0	0
BE	elongazione asta $N_{1, BE} \epsilon_{BE} L_{BE}$				Fb ² /EJ	
	totali				13/8Fb ² /EJ	5/3Xb/EJ
	iperstatica X=W _{cd}				-39/40Fb	

Sviluppi di calcolo iperstatica

$$L_{BC}^{xx} = \int_0^b (x^2/b^2) 1/EJ dx = [1/3 x^3/b^2]_0^b 1/EJ$$

$$= (1/3 b) 1/EJ = 1/3 b/EJ$$

$$L_{CB}^{xx} = \int_0^b (1 - 2x/b + x^2/b^2) 1/EJ dx = [x - x^2/b + 1/3 x^3/b^2]_0^b 1/EJ$$

$$= (b - b + 1/3 b) 1/EJ = 1/3 b/EJ$$

$$L_{CD}^{xx} = \int_0^b (1) 1/EJ dx = [x]_0^b 1/EJ$$

$$= (b) 1/EJ = b/EJ$$

$$L_{DC}^{xx} = \int_0^b (1) 1/EJ dx = [x]_0^b 1/EJ$$

$$= (b) 1/EJ = b/EJ$$

$$L_{DE}^{xx} = \int_0^b (1 - 2x/b + x^2/b^2) 1/EJ dx = [x - x^2/b + 1/3 x^3/b^2]_0^b 1/EJ$$

$$= (b - b + 1/3 b) 1/EJ = 1/3 b/EJ$$

$$L_{ED}^{xx} = \int_0^b (x^2/b^2) 1/EJ dx = [1/3 x^3/b^2]_0^b 1/EJ$$

$$= (1/3 b) 1/EJ = 1/3 b/EJ$$

$$L_{BC}^{xo} = \int_0^b (3/2 x/b - 1/2 x^2/b^2) Fb 1/EJ dx = [3/4 x^2/b - 1/6 x^3/b^2]_0^b Fb 1/EJ$$

$$= (3/4 b - 1/6 b) Fb 1/EJ = 7/12 Fb^2/EJ$$

$$L_{CB}^{xo} = \int_0^b (1 - 1/2 x/b - 1/2 x^2/b^2) Fb 1/EJ dx = [x - 1/4 x^2/b - 1/6 x^3/b^2]_0^b Fb 1/EJ$$

$$= (b - 1/4 b - 1/6 b) Fb 1/EJ = 7/12 Fb^2/EJ$$

$$L_{DE}^{xo} = \int_0^b (1/2 x/b - x^2/b^2 + 1/2 x^3/b^3) Fb 1/EJ dx = [1/4 x^2/b - 1/3 x^3/b^2 + 1/8 x^4/b^3]_0^b Fb 1/EJ$$

$$= (1/4 b - 1/3 b + 1/8 b) Fb 1/EJ = 1/24 Fb^2/EJ$$

$$L_{ED}^{xo} = \int_0^b (1/2 x^2/b^2 - 1/2 x^3/b^3) Fb 1/EJ dx = [1/6 x^3/b^2 - 1/8 x^4/b^3]_0^b Fb 1/EJ$$

$$= (1/6 b - 1/8 b) Fb 1/EJ = 1/24 Fb^2/EJ$$

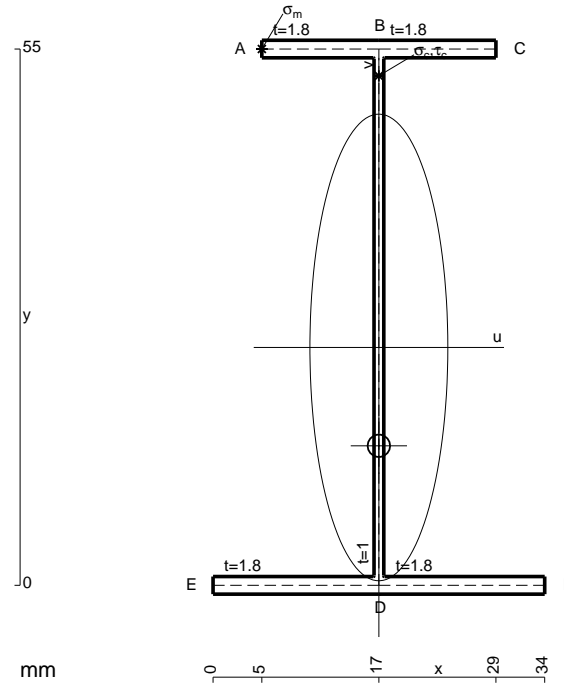

$$A = 159.4 \text{ mm}^2$$

$$J_u = 91280. \text{ mm}^4$$

$$J_v = 7969. \text{ mm}^4$$

$$J_t = 131.1 \text{ mm}^4$$

$$y_o = -10.08 \text{ mm}$$

$$y_g = 24.39 \text{ mm}$$

$$N = -1880. \text{ N}$$

$$T_y = -940. \text{ N}$$

$$M_x = 676800. \text{ Nmm}$$

$$x_m = 5. \text{ mm}$$

$$y_m = 55. \text{ mm}$$

$$u_m = -12. \text{ mm}$$

$$v_m = 30.61 \text{ mm}$$

$$\sigma_m = N/A - Mv/J_u = -238.7 \text{ N/mm}^2$$

$$x_c = 17. \text{ mm}$$

$$y_c = 55. \text{ mm}$$

$$v_c = 30.61 \text{ mm}$$

$$\sigma_c = N/A - Mv/J_u = -238.7 \text{ N/mm}^2$$

$$\tau_c = TS/tJ_u = 13.62 \text{ N/mm}^2$$

$$\tau_g = TS/tJ_u = 13.62 \text{ N/mm}^2$$

$$t_c = 470. \text{ mm}$$

$$\sigma_o = \sqrt{\sigma^2 + 3\tau^2} = 239.9 \text{ N/mm}^2$$

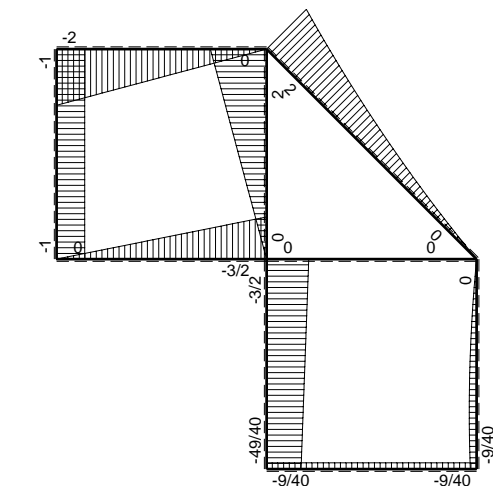
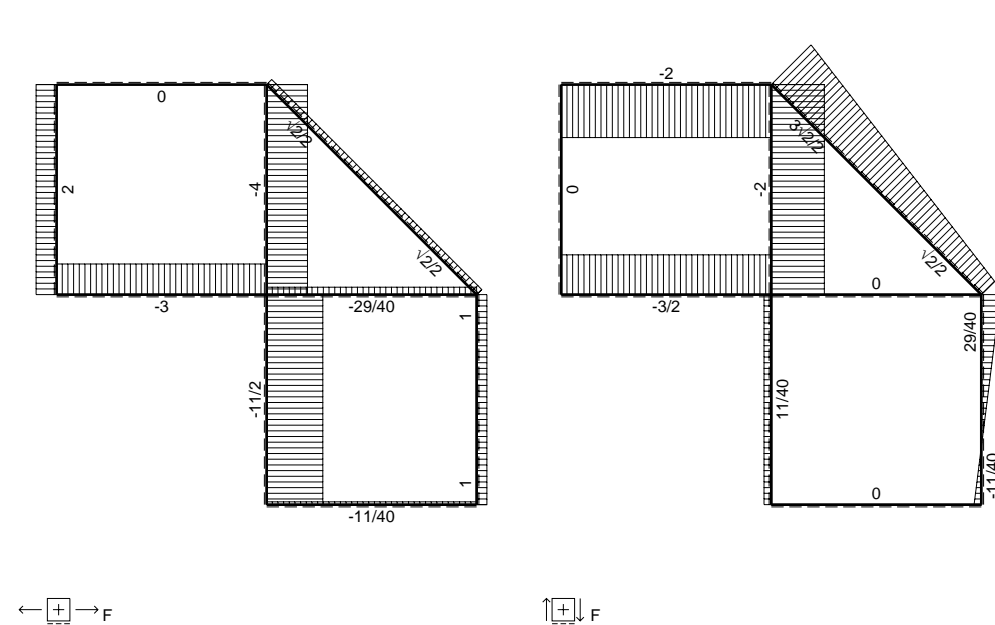
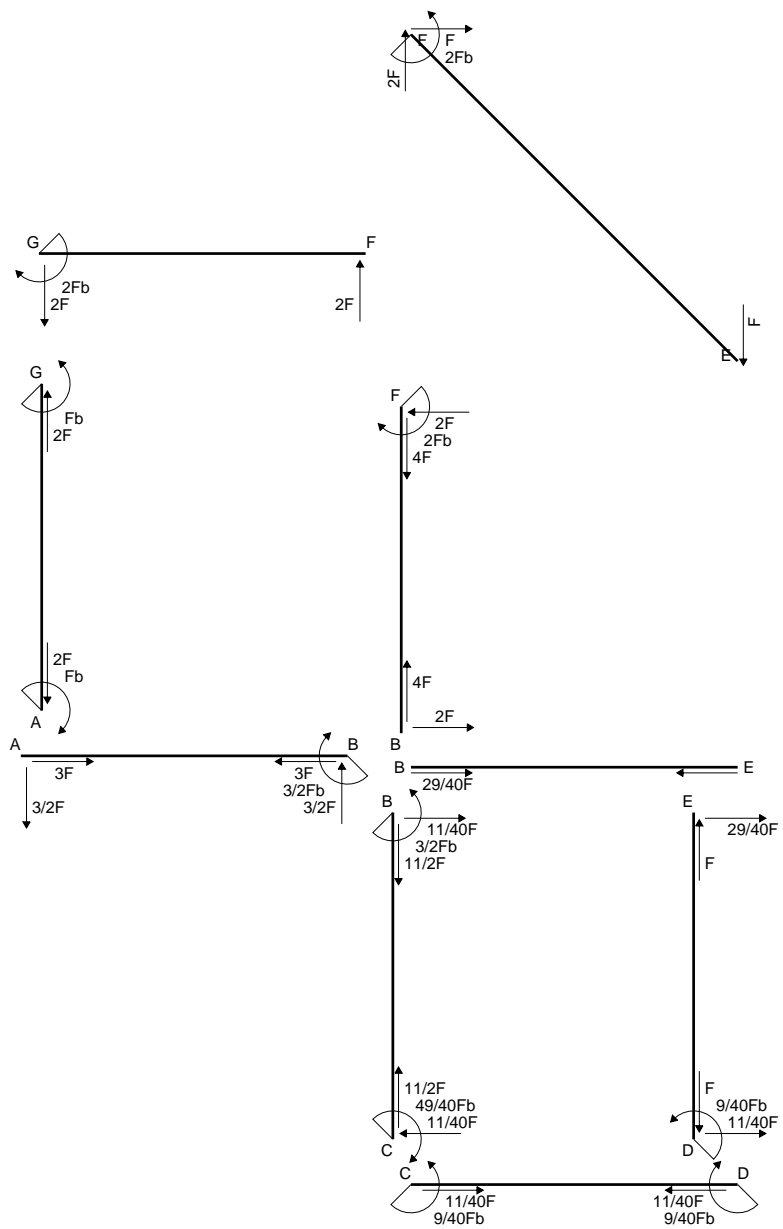

$\leftarrow \boxed{+} \rightarrow F_b$

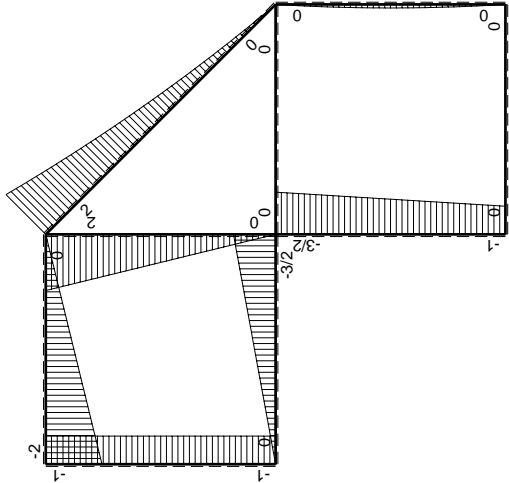
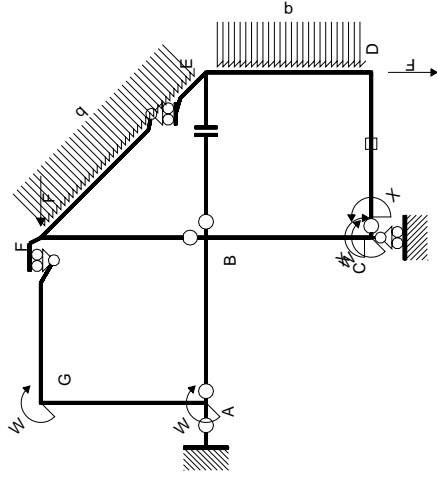

Schema di calcolo iperstatico

M_0 flessione da carichi assegnati

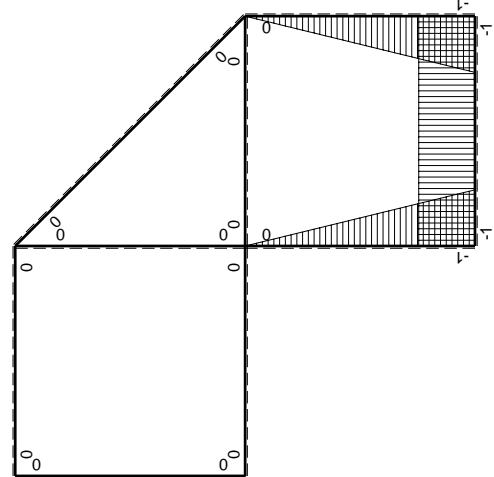

M_x flessione da iperstatica X=1

Quadro contribuiti PLV per iperstatica X=W_{cd}

→	$M_x(x)$	$M_0(x)$	$M_x M_0$	$M_x M_x$	$\int M_x M_0 / EJ dx$	$\int X M_x M_x / EJ dx$
AB b	0	-3/2Fx	0	0	0	0
BA b	0	3/2Fb-3/2Fx	0	0	0	0
BC b	-x/b	-3/2Fb+1/2Fx	3/2Fx-1/2Fx ² /b	x ² /b ²	7/12Fb ² /EJ	1/3Xb/EJ
CB b	1-x/b	Fb+1/2Fx	Fb-1/2Fx-1/2Fx ² /b	1-2x/b+x ² /b ²	0	Xb/EJ
CD b	-1	0	0	1	0	0
DC b	1	0	0	1	0	0
DE b	-1+x/b	-1/2Fx+1/2qx ²	1/2Fx-Fx ² /b+1/2qx ³ /b	1-2x/b+x ² /b ²	1/24Fb ² /EJ	1/3Xb/EJ
ED b	x/b	1/2Fx-1/2qx ²	1/2Fx ² /b-1/2qx ³ /b	x ² /b ²	0	0
EF √2b	0	√2/2Fx+1/2qx ²	0	0	0	0
FG b	0	-2Fx	0	0	0	0
GF b	0	2Fb-2Fx	0	0	0	0
GA b	0	-Fb	0	0	0	0
AG b	0	Fb	0	0	0	0
FB b	0	2Fb-2Fx	0	0	0	0
BF b	0	-2Fx	0	0	0	0
BE b	0	0	0	0	0	0
EB b	0	0	0	0	0	0
CD	elongazione asta $N_{1,cd} \epsilon_{cd} L_{cd}$				-Fb ² /EJ	
	totali				-3/8Fb ² /EJ	5/3Xb/EJ
	iperstatica X=W _{cd}				9/40Fb	

Sviluppi di calcolo iperstatica

$$L_{BC}^{xx} = \int_0^b (x^2/b^2) 1/EJ dx = [1/3 x^3/b^2]_0^b 1/EJ$$

$$= (1/3 b) 1/EJ = 1/3 b/EJ$$

$$L_{CB}^{xx} = \int_0^b (1 - 2x/b + x^2/b^2) 1/EJ dx = [x - x^2/b + 1/3 x^3/b^2]_0^b 1/EJ$$

$$= (b - b + 1/3 b) 1/EJ = 1/3 b/EJ$$

$$L_{CD}^{xx} = \int_0^b (1) 1/EJ dx = [x]_0^b 1/EJ$$

$$= (b) 1/EJ = b/EJ$$

$$L_{DC}^{xx} = \int_0^b (1) 1/EJ dx = [x]_0^b 1/EJ$$

$$= (b) 1/EJ = b/EJ$$

$$L_{DE}^{xx} = \int_0^b (1 - 2x/b + x^2/b^2) 1/EJ dx = [x - x^2/b + 1/3 x^3/b^2]_0^b 1/EJ$$

$$= (b - b + 1/3 b) 1/EJ = 1/3 b/EJ$$

$$L_{ED}^{xx} = \int_0^b (x^2/b^2) 1/EJ dx = [1/3 x^3/b^2]_0^b 1/EJ$$

$$= (1/3 b) 1/EJ = 1/3 b/EJ$$

$$L_{BC}^{xo} = \int_0^b (3/2 x/b - 1/2 x^2/b^2) Fb 1/EJ dx = [3/4 x^2/b - 1/6 x^3/b^2]_0^b Fb 1/EJ$$

$$= (3/4 b - 1/6 b) Fb 1/EJ = 7/12 Fb^2/EJ$$

$$L_{CB}^{xo} = \int_0^b (1 - 1/2 x/b - 1/2 x^2/b^2) Fb 1/EJ dx = [x - 1/4 x^2/b - 1/6 x^3/b^2]_0^b Fb 1/EJ$$

$$= (b - 1/4 b - 1/6 b) Fb 1/EJ = 7/12 Fb^2/EJ$$

$$L_{DE}^{xo} = \int_0^b (1/2 x/b - x^2/b^2 + 1/2 x^3/b^3) Fb 1/EJ dx = [1/4 x^2/b - 1/3 x^3/b^2 + 1/8 x^4/b^3]_0^b Fb 1/EJ$$

$$= (1/4 b - 1/3 b + 1/8 b) Fb 1/EJ = 1/24 Fb^2/EJ$$

$$L_{ED}^{xo} = \int_0^b (1/2 x^2/b^2 - 1/2 x^3/b^3) Fb 1/EJ dx = [1/6 x^3/b^2 - 1/8 x^4/b^3]_0^b Fb 1/EJ$$

$$= (1/6 b - 1/8 b) Fb 1/EJ = 1/24 Fb^2/EJ$$

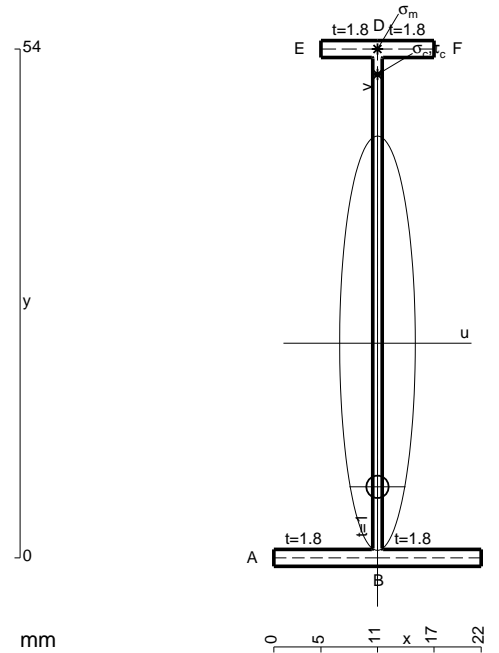

- A = 115.2 mm²
- J_u = 55687. mm⁴
- J_v = 1856. mm⁴
- J_i = 84.1 mm⁴
- y_o = -15.24 mm
- y_g = 22.78 mm
- N = 162.6 N
- T_y = 487.9 N
- M_x = 349600. Nmm
- x_m = 11. mm
- y_m = 54. mm
- v_m = 31.22 mm
- σ_m = N/A-Mv/J_u = -194.6 N/mm²
- y_c = 2. mm
- u_c = -11. mm
- v_c = -20.78 mm
- σ_c = N/A-Mv/J_u = -194.6 N/mm²
- τ_c = TS/tJ_u = 5.908 N/mm²
- τ_g = TS/tJ_u = 5.908 N/mm²
- t_c = 230. mm
- σ_o = √σ²+3τ² = 194.8 N/mm²

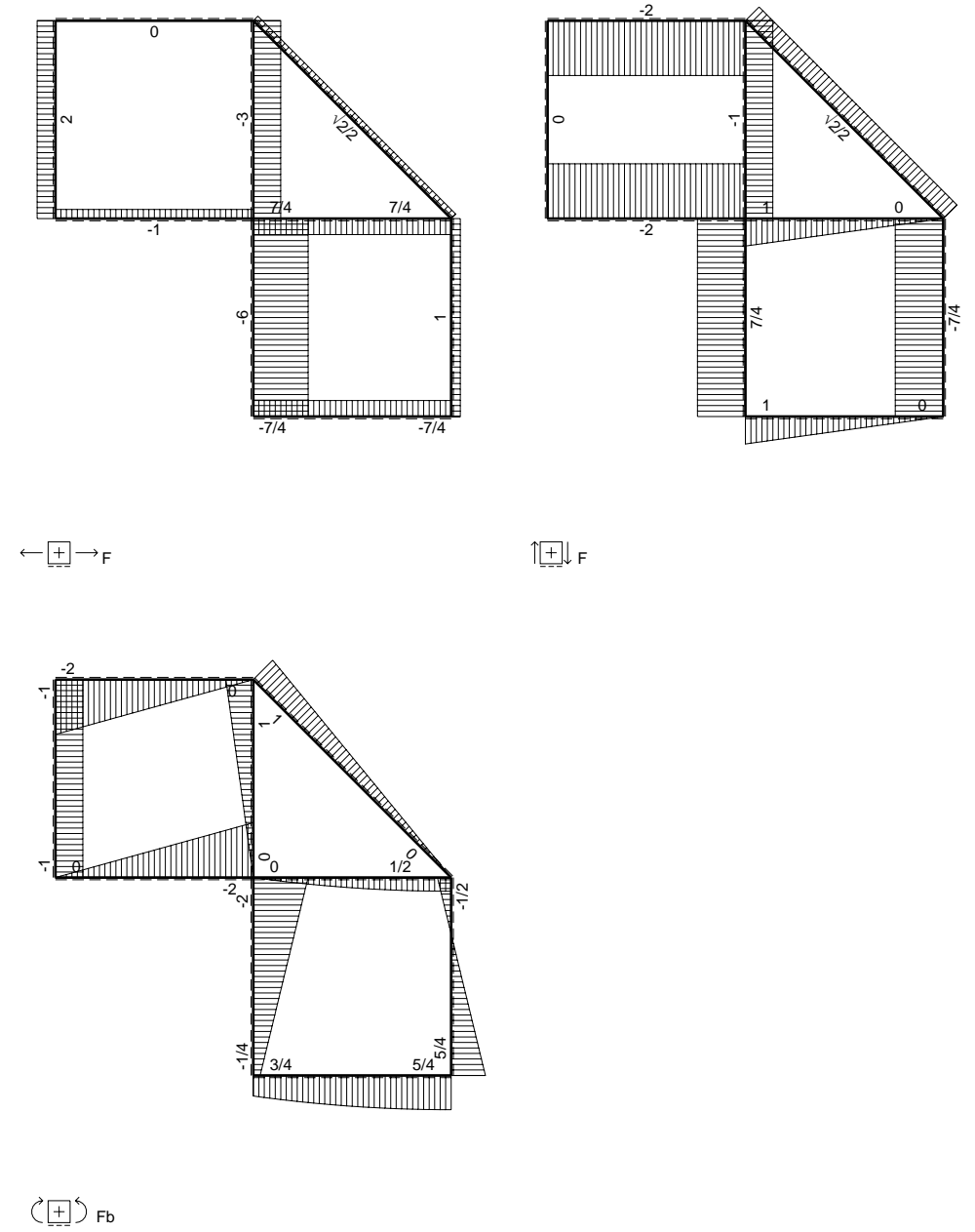
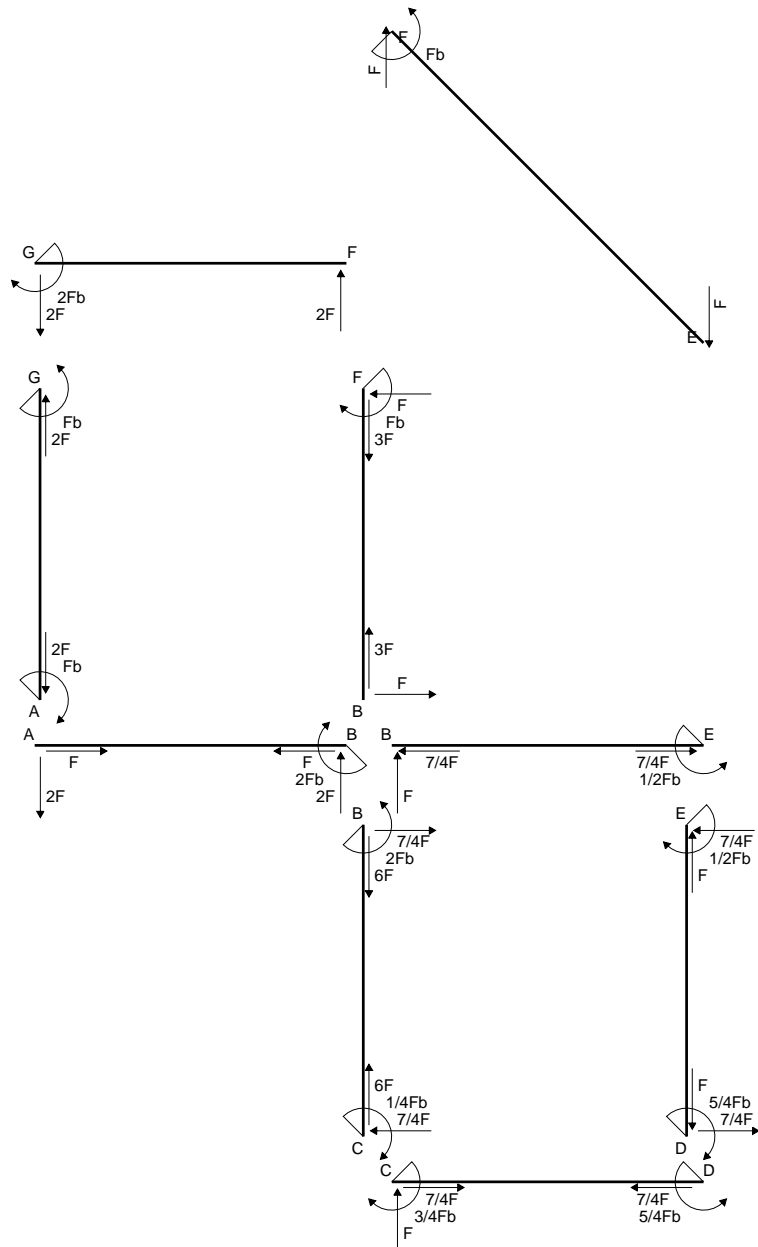

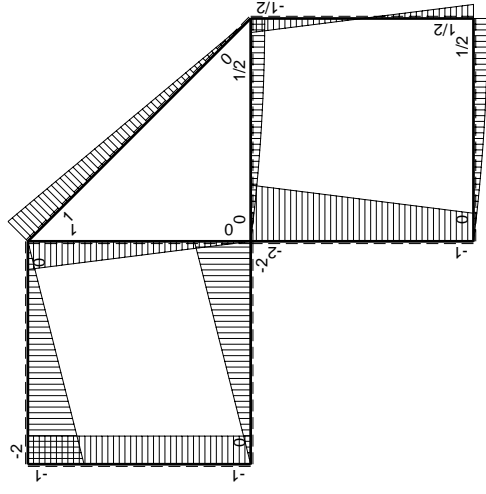
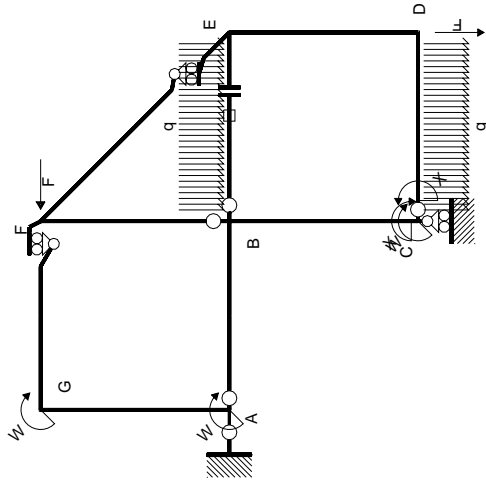

M_0 flessione da carichi assegnati

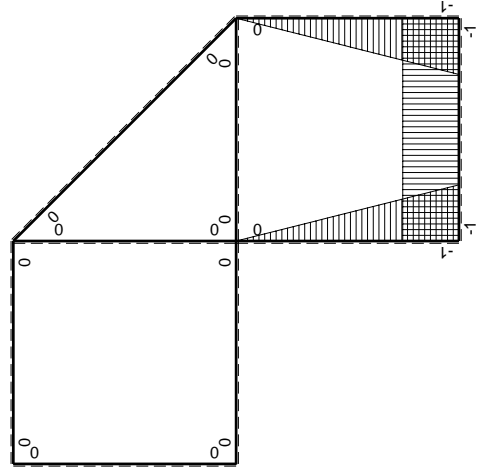

M_x flessione da iperstatica $X=1$

Quadro contribuiti PLV per iperstatica $X=W_{cd}$

\rightarrow	$M_x(x)$	$M_0(x)$	$M_x M_0$	$M_x M_x$	$\int M_x M_0 / EJ dx$	$\int X M_x M_x / EJ dx$
AB b	0	-2Fx	0	0	0	0
BA b	0	2Fb-2Fx	0	0	0	0
BC b	-x/b	-2Fb+Fx	2Fx-Fx ² /b	x ² /b ²	2/3Fb ² /EJ	1/3Xb/EJ
CB b	1-x/b	Fb+Fx	Fb-Fx ² /b	1-2x/b+x ² /b ²	-1/3Fb ² /EJ	Xb/EJ
CD b	-1	Fx-1/2qx ²	-Fx+1/2Fx ² /b	1	-1/3Fb ² /EJ	Xb/EJ
DC b	1	-1/2Fb+1/2qx ²	-1/2Fb+1/2Fx ² /b	1	-1/12Fb ² /EJ	1/3Xb/EJ
DE b	-1+x/b	1/2Fb-Fx	-1/2Fb+3/2Fx-Fx ² /b	1-2x/b+x ² /b ²	-1/12Fb ² /EJ	1/3Xb/EJ
ED b	x/b	1/2Fb-Fx	1/2Fx-Fx ² /b	x ² /b ²	-1/12Fb ² /EJ	1/3Xb/EJ
EF $\sqrt{2}b$	0	$\sqrt{2}2Fx$	0	0	0	0
FG b	0	-2Fx	0	0	0	0
GF b	0	2Fb-2Fx	0	0	0	0
GA b	0	-Fb	0	0	0	0
AG b	0	Fb	0	0	0	0
FB b	0	Fb-Fx	0	0	0	0
BF b	0	-Fx	0	0	0	0
BE b	0	Fx-1/2qx ²	0	0	0	0
EB b	0	-1/2Fb+1/2qx ²	0	0	0	0
BE	elongazione asta $N_{1BE} \epsilon_{BE} = L_{BE}$				Fb ² /EJ	
	totali				5/4Fb ² /EJ	5/3Xb/EJ
	iperstatica $X=W_{cd}$				-3/4Fb	

Sviluppi di calcolo iperstatica

$$L_{BC}^{xx} = \int_0^b (x^2/b^2) 1/EJ dx = [1/3 x^3/b^2]_0^b 1/EJ$$

$$= (1/3 b) 1/EJ = 1/3 b/EJ$$

$$L_{CB}^{xx} = \int_0^b (1 - 2x/b + x^2/b^2) 1/EJ dx = [x - x^2/b + 1/3 x^3/b^2]_0^b 1/EJ$$

$$= (b - b + 1/3 b) 1/EJ = 1/3 b/EJ$$

$$L_{CD}^{xx} = \int_0^b (1) 1/EJ dx = [x]_0^b 1/EJ$$

$$= (b) 1/EJ = b/EJ$$

$$L_{DC}^{xx} = \int_0^b (1) 1/EJ dx = [x]_0^b 1/EJ$$

$$= (b) 1/EJ = b/EJ$$

$$L_{DE}^{xx} = \int_0^b (1 - 2x/b + x^2/b^2) 1/EJ dx = [x - x^2/b + 1/3 x^3/b^2]_0^b 1/EJ$$

$$= (b - b + 1/3 b) 1/EJ = 1/3 b/EJ$$

$$L_{ED}^{xx} = \int_0^b (x^2/b^2) 1/EJ dx = [1/3 x^3/b^2]_0^b 1/EJ$$

$$= (1/3 b) 1/EJ = 1/3 b/EJ$$

$$L_{BC}^{xo} = \int_0^b (2x/b - x^2/b^2) Fb 1/EJ dx = [x^2/b - 1/3 x^3/b^2]_0^b Fb 1/EJ$$

$$= (b - 1/3 b) Fb 1/EJ = 2/3 Fb^2/EJ$$

$$L_{CB}^{xo} = \int_0^b (1 - x^2/b^2) Fb 1/EJ dx = [x - 1/3 x^3/b^2]_0^b Fb 1/EJ$$

$$= (b - 1/3 b) Fb 1/EJ = 2/3 Fb^2/EJ$$

$$L_{CD}^{xo} = \int_0^b (-x/b + 1/2 x^2/b^2) Fb 1/EJ dx = [-1/2 x^2/b + 1/6 x^3/b^2]_0^b Fb 1/EJ$$

$$= (-1/2 b + 1/6 b) Fb 1/EJ = -1/3 Fb^2/EJ$$

$$L_{DC}^{xo} = \int_0^b (-1/2 + 1/2 x^2/b^2) Fb 1/EJ dx = [-1/2 x + 1/6 x^3/b^2]_0^b Fb 1/EJ$$

$$= (-1/2 b + 1/6 b) Fb 1/EJ = -1/3 Fb^2/EJ$$

$$L_{DE}^{xo} = \int_0^b (-1/2 + 3/2 x/b - x^2/b^2) Fb 1/EJ dx = [-1/2 x + 3/4 x^2/b - 1/3 x^3/b^2]_0^b Fb 1/EJ$$

$$= (-1/2 b + 3/4 b - 1/3 b) Fb 1/EJ = -1/12 Fb^2/EJ$$

$$L_{ED}^{xo} = \int_0^b (1/2 x/b - x^2/b^2) Fb 1/EJ dx = [1/4 x^2/b - 1/3 x^3/b^2]_0^b Fb 1/EJ$$

$$= (1/4 b - 1/3 b) Fb 1/EJ = -1/12 Fb^2/EJ$$

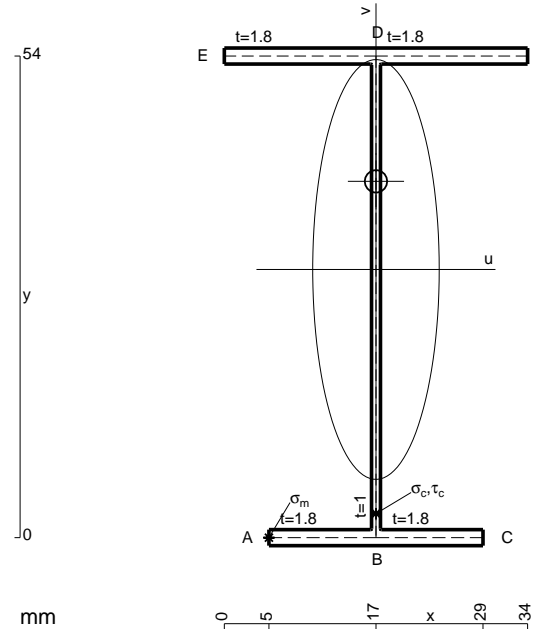

- A = 158.4 mm²
- J_u = 87739. mm⁴
- J_v = 7969. mm⁴
- J_t = 130.8 mm⁴
- y_o = 9.881 mm
- y_g = 30.07 mm
- N = -370. N
- T_y = -740. N
- M_x = -599400. Nmm
- x_m = 5. mm
- u_m = -12. mm
- v_m = -30.07 mm
- σ_m = N/A-Mv/J_u = -207.8 N/mm²
- x_c = 17. mm
- v_c = -30.07 mm
- σ_c = N/A-Mv/J_u = -207.8 N/mm²
- τ_c = TS¹/tJ_u = 10.96 N/mm²
- τ_g = TS¹/tJ_u = 10.96 N/mm²
- t_c = 370. mm
- σ_o = √σ²+3τ² = 208.6 N/mm²

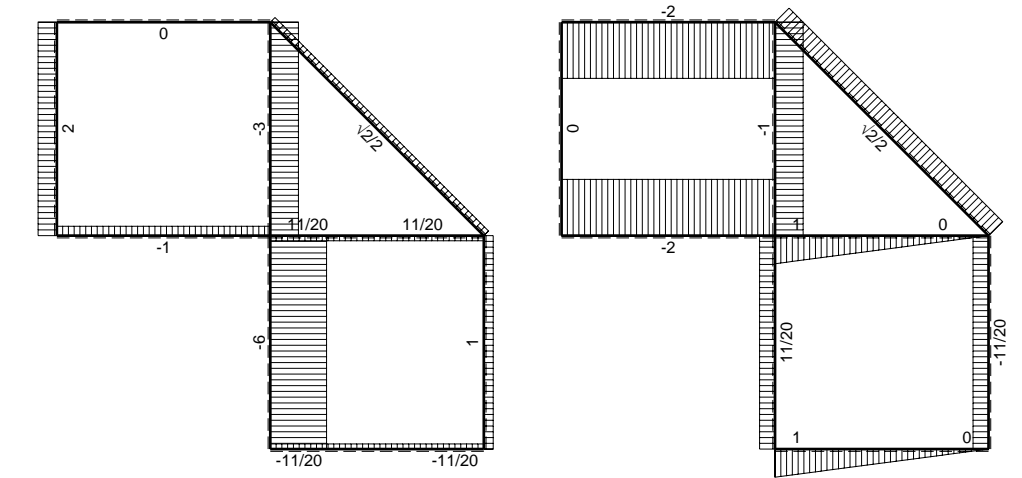
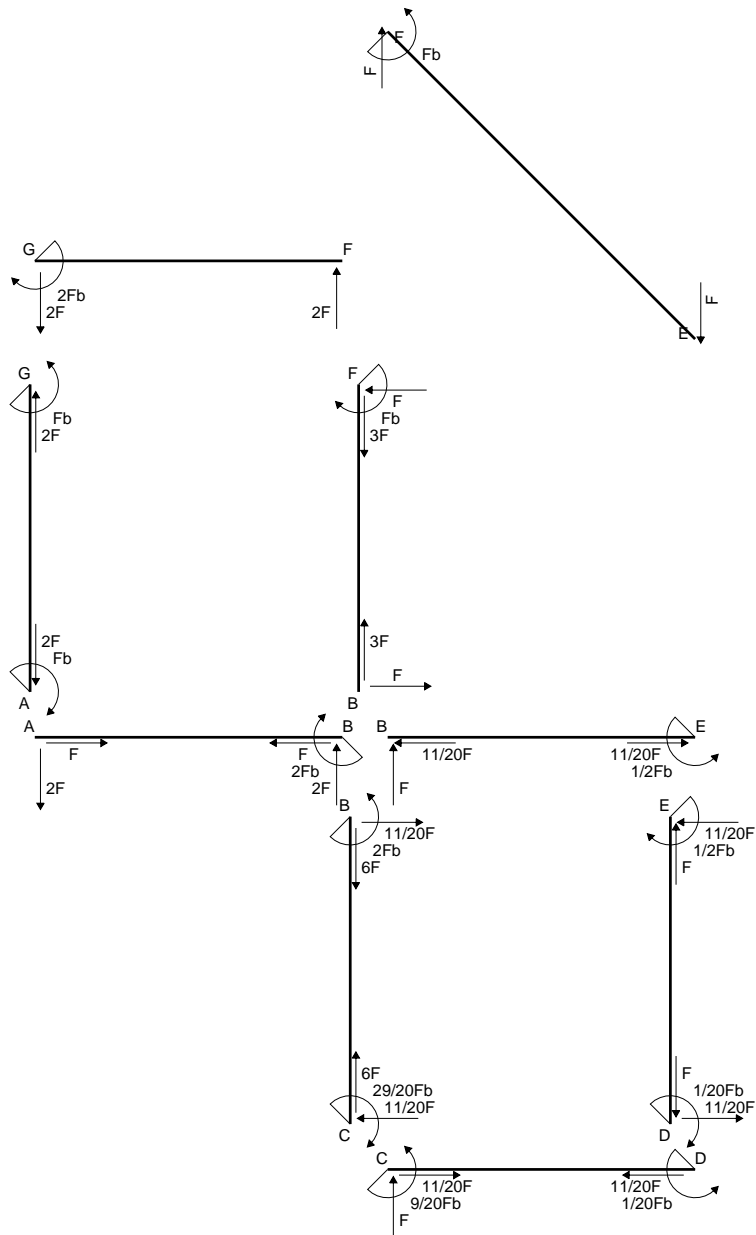

← ⊕ → F

↑ ⊕ ↓ F

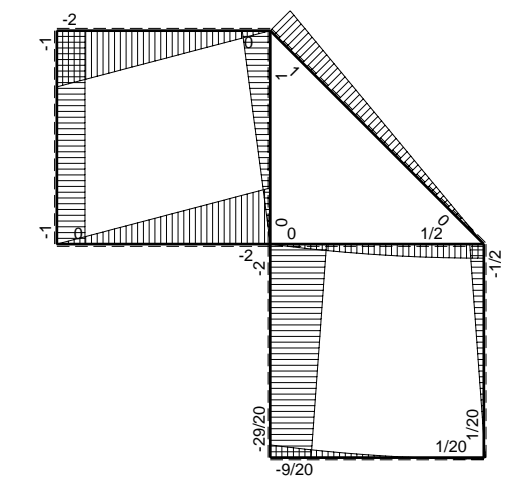

⊕ ⊖ F_b

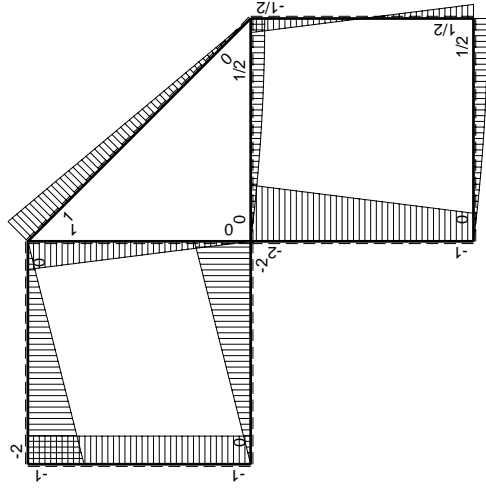
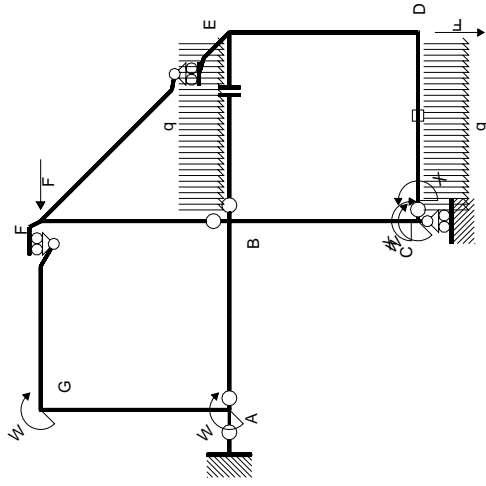

(\oplus) M_0 flessione da carichi assegnati

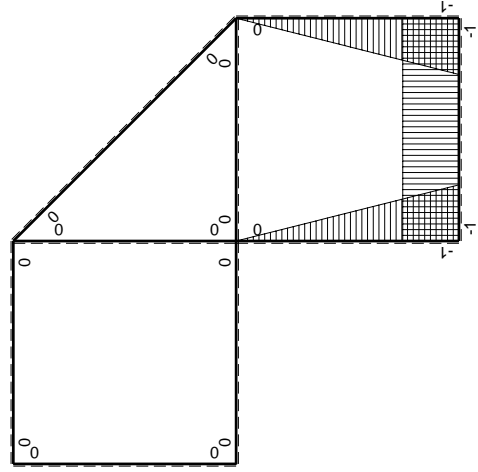

(\oplus) M_x flessione da iperstatica $X=1$

Quadro contribuiti PLV per iperstatica $X=W_{cd}$

\rightarrow	$M_x(x)$	$M_0(x)$	$M_x M_0$	$M_x^2 M_x$	$\int M_x M_0 / EJ dx$	$\int X M_x^2 M_x / EJ dx$
AB b	0	-2Fx	0	0	0	0
BA b	0	2Fb-2Fx	0	0	0	0
BC b	-x/b	-2Fb+Fx	2Fx-Fx ² /b	x ² /b ²	2/3Fb ² /EJ	1/3Xb/EJ
CB b	1-x/b	Fb+Fx	Fb-Fx ² /b	1-2x/b+x ² /b ²	-1/3Fb ² /EJ	Xb/EJ
CD b	-1	Fx-1/2qx ²	-Fx+1/2Fx ² /b	1	-1/12Fb ² /EJ	1/3Xb/EJ
DC b	1	-1/2Fb+1/2qx ²	-1/2Fb+1/2Fx ² /b	1	-1/12Fb ² /EJ	1/3Xb/EJ
DE b	-1+x/b	1/2Fb-Fx	-1/2Fb+3/2Fx-Fx ² /b	1-2x/b+x ² /b ²	-1/12Fb ² /EJ	1/3Xb/EJ
ED b	x/b	1/2Fb-Fx	1/2Fx-Fx ² /b	x ² /b ²	0	0
EF $\sqrt{2}b$	0	$\sqrt{2}2Fx$	0	0	0	0
FG b	0	-2Fx	0	0	0	0
GF b	0	2Fb-2Fx	0	0	0	0
GA b	0	-Fb	0	0	0	0
AG b	0	Fb	0	0	0	0
FB b	0	Fb-Fx	0	0	0	0
BF b	0	-Fx	0	0	0	0
BE b	0	Fx-1/2qx ²	0	0	0	0
EB b	0	-1/2Fb+1/2qx ²	0	0	0	0
CD	elongazione asta $N_{1,cd} \epsilon_{cd} l_{cd}$				-Fb ² /EJ	
	totali				-3/4Fb ² /EJ	5/3Xb/EJ
	iperstatica $X=W_{cd}$				9/20Fb	

Sviluppi di calcolo iperstatica

$$L_{BC}^{xx} = \int_0^b (x^2/b^2) 1/EJ dx = [1/3 x^3/b^2]_0^b 1/EJ$$

$$= (1/3 b) 1/EJ = 1/3 b/EJ$$

$$L_{CB}^{xx} = \int_0^b (1 - 2x/b + x^2/b^2) 1/EJ dx = [x - x^2/b + 1/3 x^3/b^2]_0^b 1/EJ$$

$$= (b - b + 1/3 b) 1/EJ = 1/3 b/EJ$$

$$L_{CD}^{xx} = \int_0^b (1) 1/EJ dx = [x]_0^b 1/EJ$$

$$= (b) 1/EJ = b/EJ$$

$$L_{DC}^{xx} = \int_0^b (1) 1/EJ dx = [x]_0^b 1/EJ$$

$$= (b) 1/EJ = b/EJ$$

$$L_{DE}^{xx} = \int_0^b (1 - 2x/b + x^2/b^2) 1/EJ dx = [x - x^2/b + 1/3 x^3/b^2]_0^b 1/EJ$$

$$= (b - b + 1/3 b) 1/EJ = 1/3 b/EJ$$

$$L_{ED}^{xx} = \int_0^b (x^2/b^2) 1/EJ dx = [1/3 x^3/b^2]_0^b 1/EJ$$

$$= (1/3 b) 1/EJ = 1/3 b/EJ$$

$$L_{BC}^{x_0} = \int_0^b (2x/b - x^2/b^2) Fb 1/EJ dx = [x^2/b - 1/3 x^3/b^2]_0^b Fb 1/EJ$$

$$= (b - 1/3 b) Fb 1/EJ = 2/3 Fb^2/EJ$$

$$L_{CB}^{x_0} = \int_0^b (1 - x^2/b^2) Fb 1/EJ dx = [x - 1/3 x^3/b^2]_0^b Fb 1/EJ$$

$$= (b - 1/3 b) Fb 1/EJ = 2/3 Fb^2/EJ$$

$$L_{CD}^{x_0} = \int_0^b (-x/b + 1/2 x^2/b^2) Fb 1/EJ dx + 1 (-1) 1 Fb^2/EJ$$

$$= [-1/2 x^2/b + 1/6 x^3/b^2]_0^b Fb 1/EJ + 1 (-1) 1 Fb^2/EJ$$

$$= (-1/2 b + 1/6 b) Fb 1/EJ + 1 (-1) 1 Fb^2/EJ = -4/3 Fb^2/EJ$$

$$L_{DC}^{x_0} = \int_0^b (-1/2 + 1/2 x^2/b^2) Fb 1/EJ dx + 1 (-1) 1 Fb^2/EJ$$

$$= [-1/2 x + 1/6 x^3/b^2]_0^b Fb 1/EJ + 1 (-1) 1 Fb^2/EJ$$

$$= (-1/2 b + 1/6 b) Fb 1/EJ + 1 (-1) 1 Fb^2/EJ = -4/3 Fb^2/EJ$$

$$L_{DE}^{x_0} = \int_0^b (-1/2 + 3/2 x/b - x^2/b^2) Fb 1/EJ dx = [-1/2 x + 3/4 x^2/b - 1/3 x^3/b^2]_0^b Fb 1/EJ$$

$$= (-1/2 b + 3/4 b - 1/3 b) Fb 1/EJ = -1/12 Fb^2/EJ$$

$$L_{ED}^{x_0} = \int_0^b (1/2 x/b - x^2/b^2) Fb 1/EJ dx = [1/4 x^2/b - 1/3 x^3/b^2]_0^b Fb 1/EJ$$

$$= (1/4 b - 1/3 b) Fb 1/EJ = -1/12 Fb^2/EJ$$

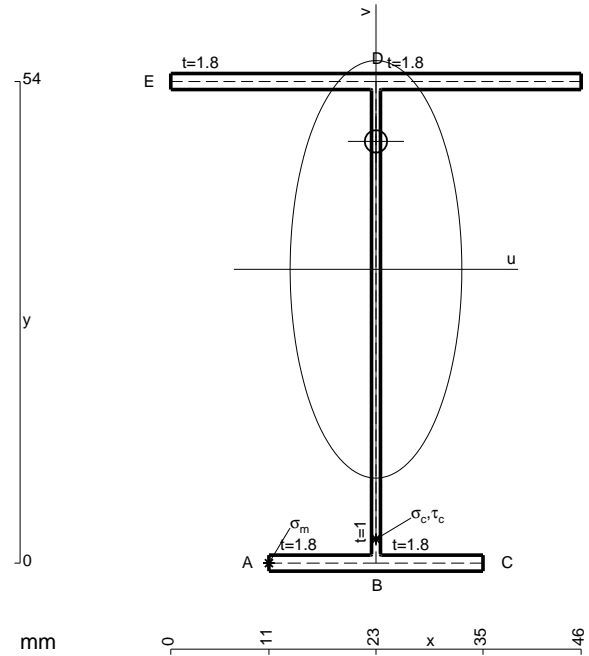

- A = 180. mm²
- J_u = 98625. mm⁴
- J_v = 16674. mm⁴
- J_t = 154.1 mm⁴
- y_o = 14.34 mm
- y_g = 32.94 mm
- N = -370. N
- T_y = -740. N
- M_x = -636400. Nmm
- x_m = 11. mm
- u_m = -12. mm
- v_m = -32.94 mm
- σ_m = N/A-Mv/J_u = -214.6 N/mm²
- x_c = 23. mm
- v_c = -32.94 mm
- σ_c = N/A-Mv/J_v = -214.6 N/mm²
- τ_c = TS/tJ_u = 10.68 N/mm²
- τ_g = TS/tJ_v = 10.68 N/mm²
- t_c = 370. mm
- σ_o = √σ²+3τ² = 215.4 N/mm²

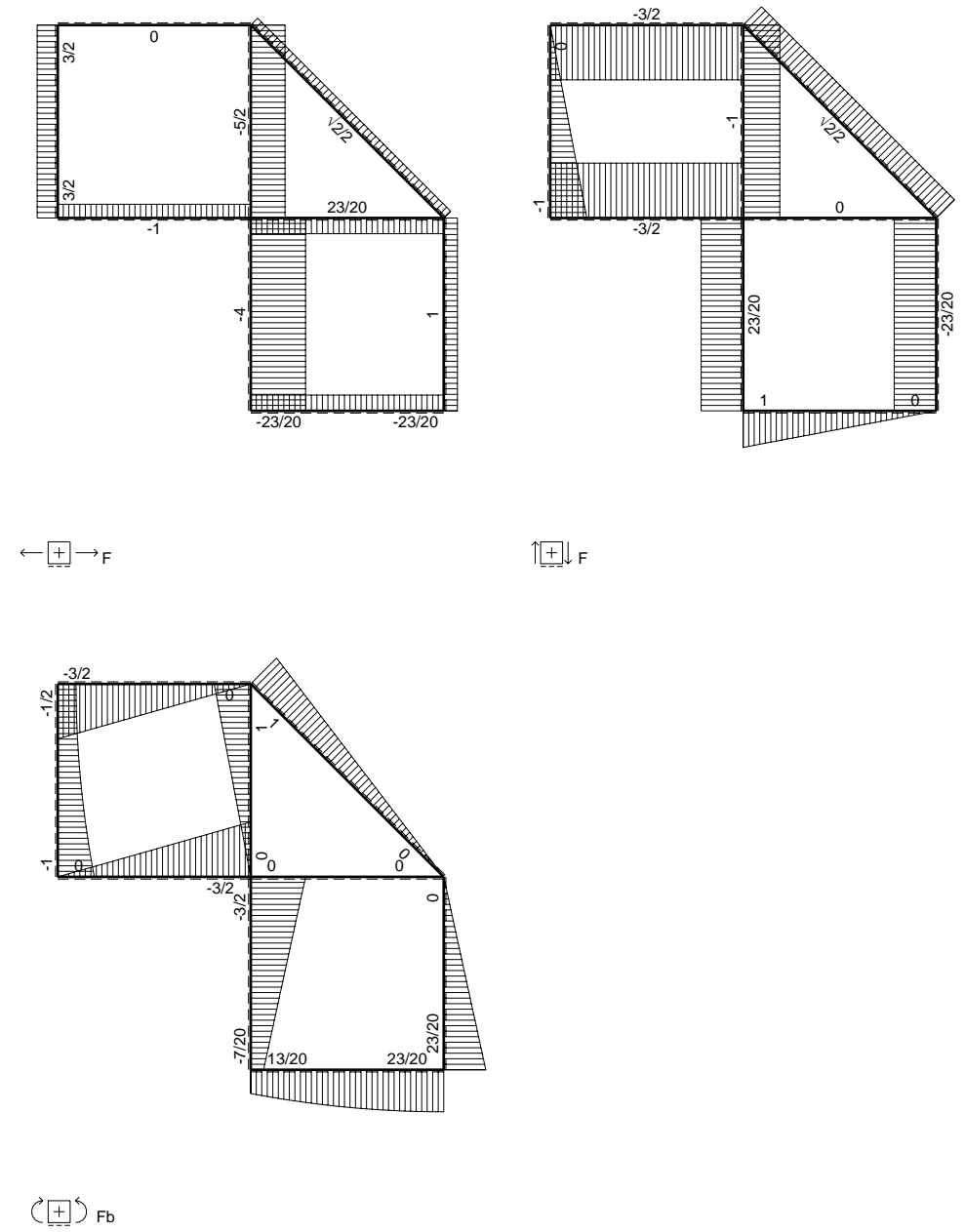
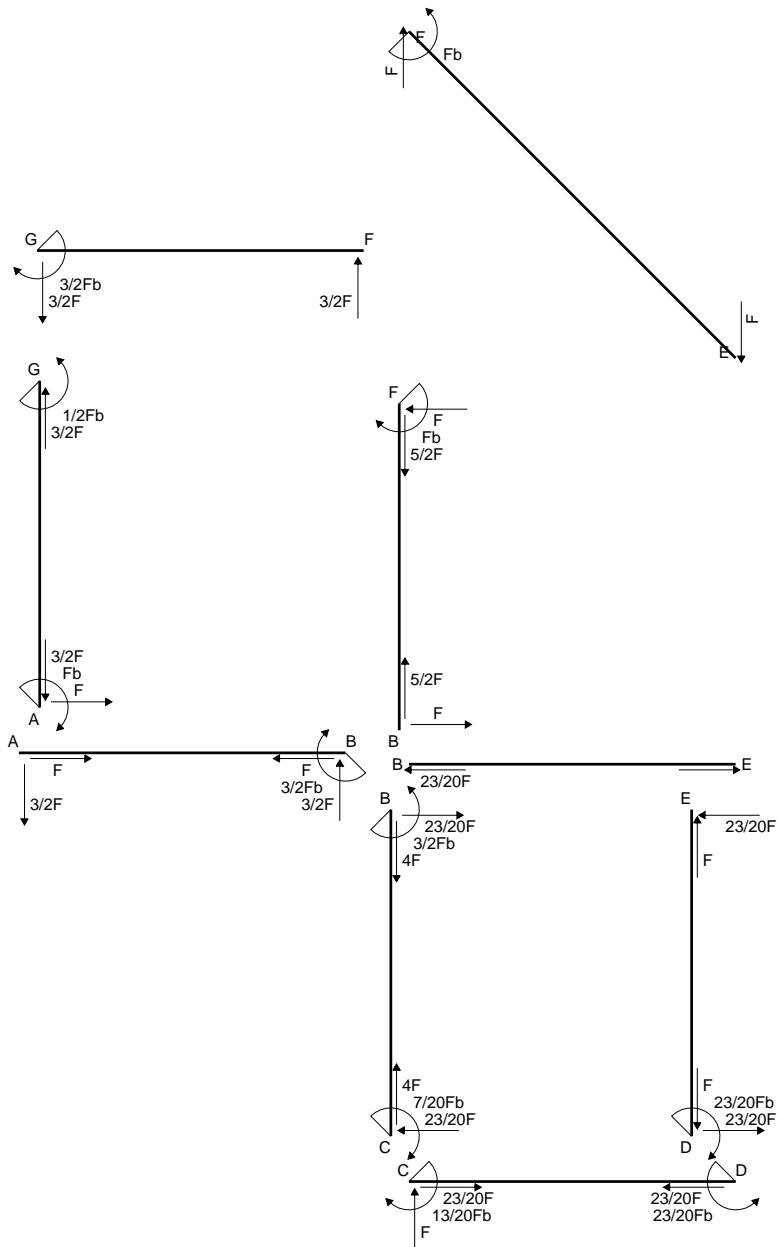

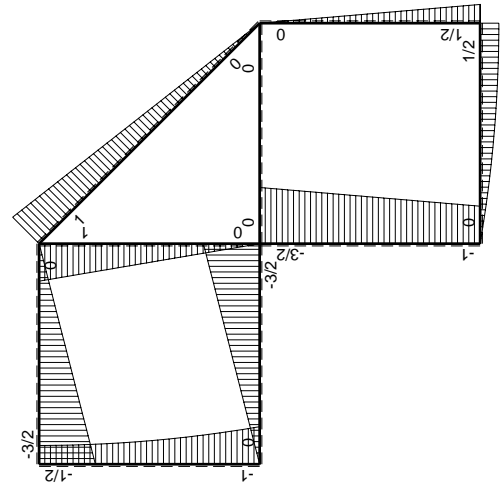
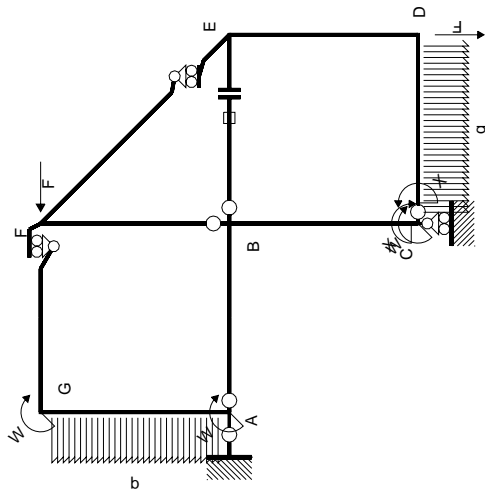

(\oplus) M_0 flessione da carichi assegnati

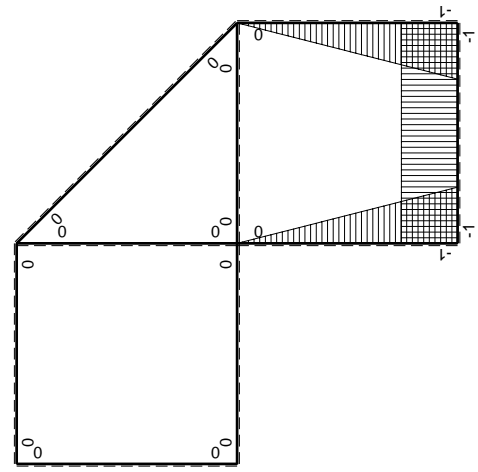

(\oplus) M_x flessione da iperstatica $X=1$

Quadro contribuiti PLV per iperstatica $X=W_{cd}$

\rightarrow	$M_x(x)$	$M_0(x)$	$M_x M_0$	$M_x M_x$	$\int M_x M_0 / EJ dx$	$\int X M_x M_x / EJ dx$
AB b	0	-3/2Fx	0	0	0	0
BA b	0	3/2Fb-3/2Fx	0	0	0	0
BC b	-x/b	-3/2Fb+1/2Fx	3/2Fx-1/2Fx ² /b	x ² /b ²	7/12Fb ² /EJ	1/3Xb/EJ
CB b	1-x/b	Fb+1/2Fx	Fb-1/2Fx-1/2Fx ² /b	1-2x/b+x ² /b ²	-1/3Fb ² /EJ	Xb/EJ
CD b	-1	Fx-1/2qx ²	-Fx+1/2Fx ² /b	1	-1/3Fb ² /EJ	Xb/EJ
DC b	1	-1/2Fb+1/2qx ²	-1/2Fb+1/2Fx ² /b	1	-1/3Fb ² /EJ	Xb/EJ
DE b	-1+x/b	1/2Fb-1/2Fx	-1/2Fb+Fx-1/2Fx ² /b	1-2x/b+x ² /b ²	-1/6Fb ² /EJ	1/3Xb/EJ
ED b	x/b	-1/2Fx	-1/2Fx ² /b	x ² /b ²	-1/6Fb ² /EJ	1/3Xb/EJ
EF $\sqrt{2}b$	0	$\sqrt{2}2Fx$	0	0	0	0
FG b	0	-3/2Fx	0	0	0	0
GF b	0	3/2Fb-3/2Fx	0	0	0	0
GA b	0	-1/2Fb-1/2qx ²	0	0	0	0
AG b	0	Fb-Fx+1/2qx ²	0	0	0	0
FB b	0	Fb-Fx	0	0	0	0
BF b	0	-Fx	0	0	0	0
BE b	0	0	0	0	0	0
EB b	0	0	0	0	0	0
BE	elongazione asta $N_{1, BE} \epsilon_{BE} = L_{BE}$				Fb ² /EJ	
	totali				13/12Fb ² /EJ	5/3Xb/EJ
	iperstatica $X=W_{cd}$				-13/20Fb	

Sviluppi di calcolo iperstatica

$$L_{BC}^{xx} = \int_0^b (x^2/b^2) 1/EJ dx = [1/3 x^3/b^2]_0^b 1/EJ$$

$$= (1/3 b) 1/EJ = 1/3 b/EJ$$

$$L_{CB}^{xx} = \int_0^b (1 - 2x/b + x^2/b^2) 1/EJ dx = [x - x^2/b + 1/3 x^3/b^2]_0^b 1/EJ$$

$$= (b - b + 1/3 b) 1/EJ = 1/3 b/EJ$$

$$L_{CD}^{xx} = \int_0^b (1) 1/EJ dx = [x]_0^b 1/EJ$$

$$= (b) 1/EJ = b/EJ$$

$$L_{DC}^{xx} = \int_0^b (1) 1/EJ dx = [x]_0^b 1/EJ$$

$$= (b) 1/EJ = b/EJ$$

$$L_{DE}^{xx} = \int_0^b (1 - 2x/b + x^2/b^2) 1/EJ dx = [x - x^2/b + 1/3 x^3/b^2]_0^b 1/EJ$$

$$= (b - b + 1/3 b) 1/EJ = 1/3 b/EJ$$

$$L_{ED}^{xx} = \int_0^b (x^2/b^2) 1/EJ dx = [1/3 x^3/b^2]_0^b 1/EJ$$

$$= (1/3 b) 1/EJ = 1/3 b/EJ$$

$$L_{BC}^{xo} = \int_0^b (3/2 x/b - 1/2 x^2/b^2) Fb 1/EJ dx = [3/4 x^2/b - 1/6 x^3/b^2]_0^b Fb 1/EJ$$

$$= (3/4 b - 1/6 b) Fb 1/EJ = 7/12 Fb^2/EJ$$

$$L_{CB}^{xo} = \int_0^b (1 - 1/2 x/b - 1/2 x^2/b^2) Fb 1/EJ dx = [x - 1/4 x^2/b - 1/6 x^3/b^2]_0^b Fb 1/EJ$$

$$= (b - 1/4 b - 1/6 b) Fb 1/EJ = 7/12 Fb^2/EJ$$

$$L_{CD}^{xo} = \int_0^b (-x/b + 1/2 x^2/b^2) Fb 1/EJ dx = [-1/2 x^2/b + 1/6 x^3/b^2]_0^b Fb 1/EJ$$

$$= (-1/2 b + 1/6 b) Fb 1/EJ = -1/3 Fb^2/EJ$$

$$L_{DC}^{xo} = \int_0^b (-1/2 + 1/2 x^2/b^2) Fb 1/EJ dx = [-1/2 x + 1/6 x^3/b^2]_0^b Fb 1/EJ$$

$$= (-1/2 b + 1/6 b) Fb 1/EJ = -1/3 Fb^2/EJ$$

$$L_{DE}^{xo} = \int_0^b (-1/2 + x/b - 1/2 x^2/b^2) Fb 1/EJ dx = [-1/2 x + 1/2 x^2/b - 1/6 x^3/b^2]_0^b Fb 1/EJ$$

$$= (-1/2 b + 1/2 b - 1/6 b) Fb 1/EJ = -1/6 Fb^2/EJ$$

$$L_{ED}^{xo} = \int_0^b (-1/2 x^2/b^2) Fb 1/EJ dx = [-1/6 x^3/b^2]_0^b Fb 1/EJ$$

$$= (-1/6 b) Fb 1/EJ = -1/6 Fb^2/EJ$$

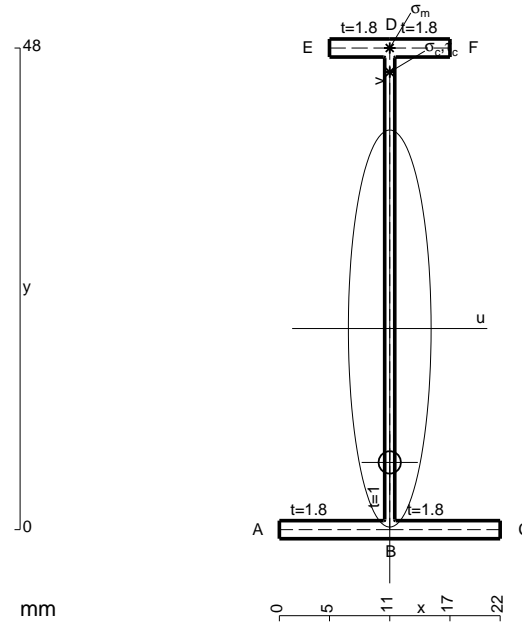

$$A = 109.2 \text{ mm}^2$$

$$J_u = 42758. \text{ mm}^4$$

$$J_v = 1856. \text{ mm}^4$$

$$J_t = 82.1 \text{ mm}^4$$

$$y_o = -13.34 \text{ mm}$$

$$y_g = 20.04 \text{ mm}$$

$$T_y = -420. \text{ N}$$

$$M_x = -340200. \text{ Nmm}$$

$$x_m = 11. \text{ mm}$$

$$y_m = 48. \text{ mm}$$

$$v_m = 27.96 \text{ mm}$$

$$\sigma_m = -Mv/J_u = 222.4 \text{ N/mm}^2$$

$$y_c = 2. \text{ mm}$$

$$u_c = -11. \text{ mm}$$

$$v_c = -18.04 \text{ mm}$$

$$\sigma_c = -Mv/J_u = 222.4 \text{ N/mm}^2$$

$$\tau_c = TS'/tJ_u = 5.931 \text{ N/mm}^2$$

$$\tau_g = TS'/tJ_u = 5.931 \text{ N/mm}^2$$

$$t_c = 280. \text{ mm}$$

$$\sigma_o = \sqrt{\sigma^2 + 3\tau^2} = 222.7 \text{ N/mm}^2$$

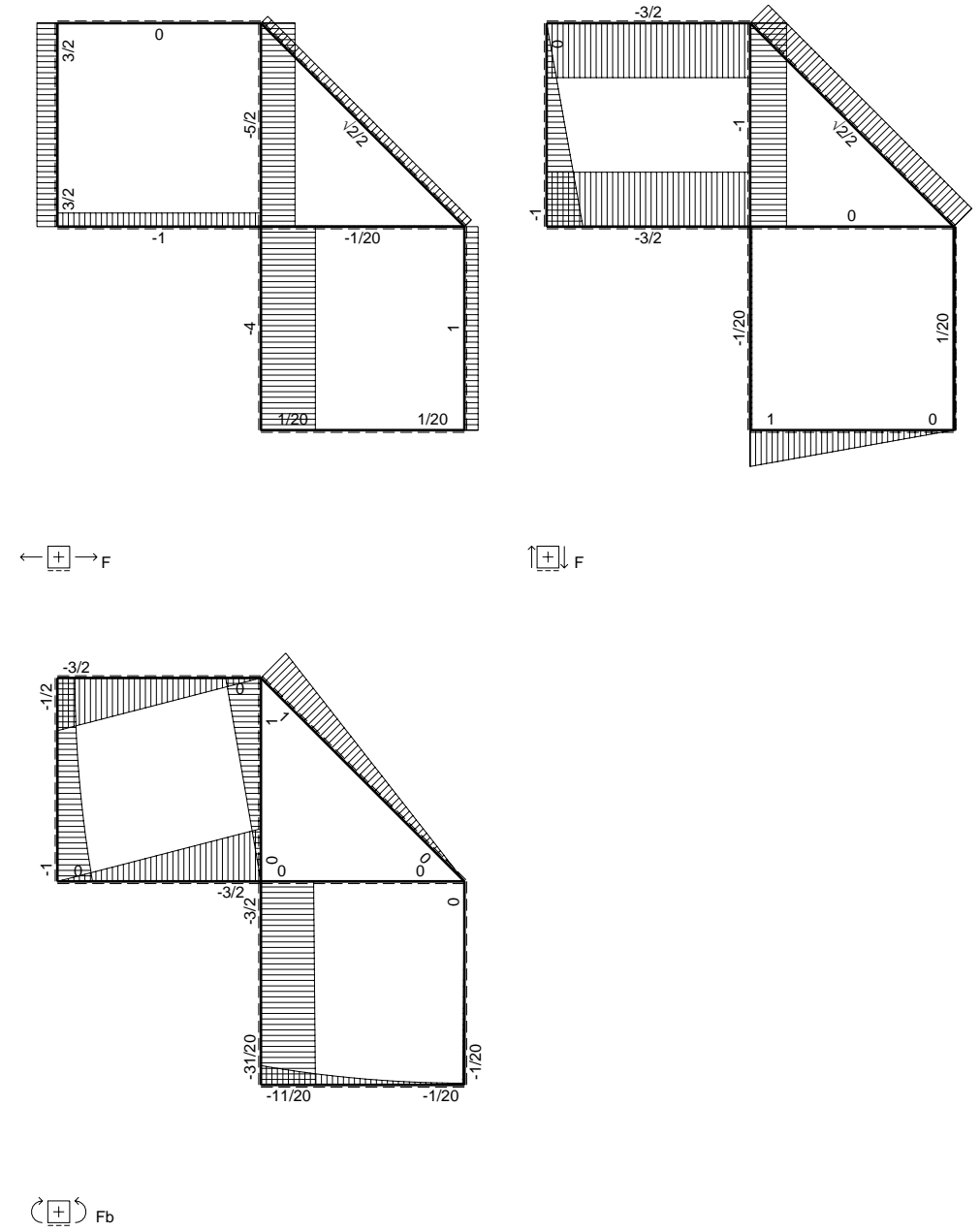
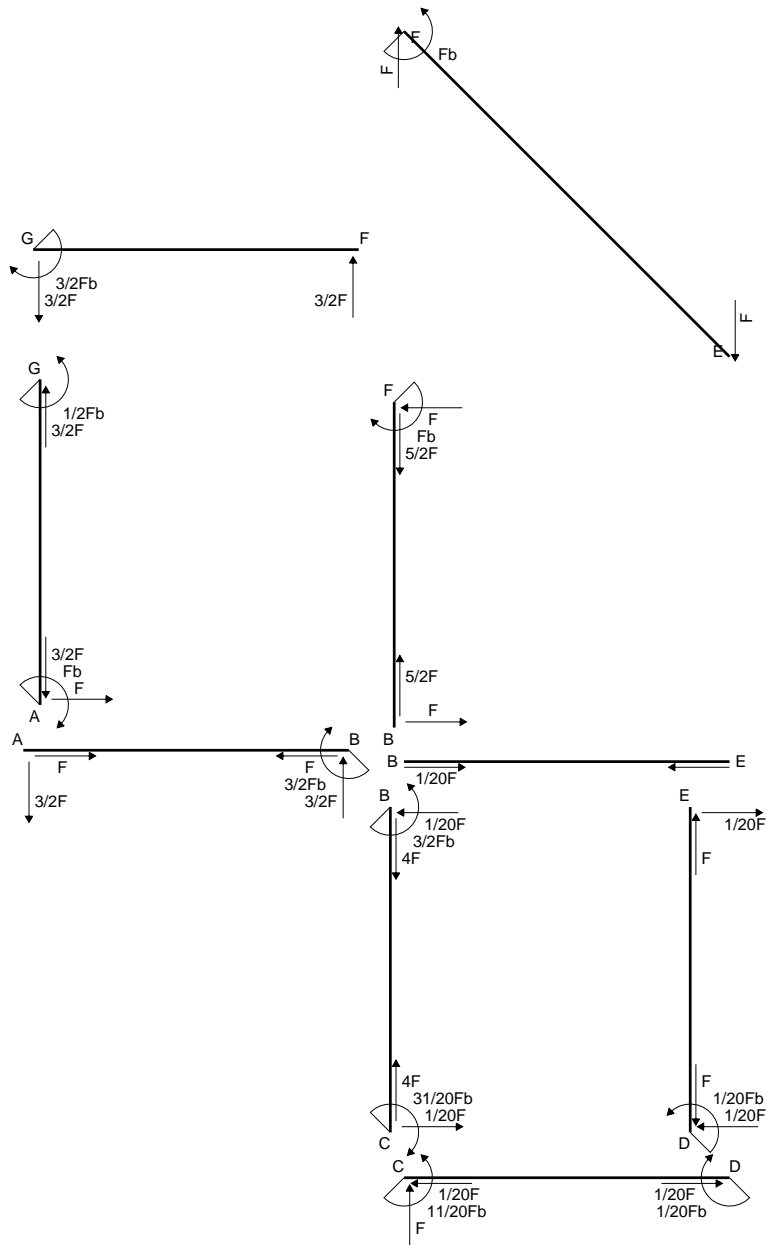

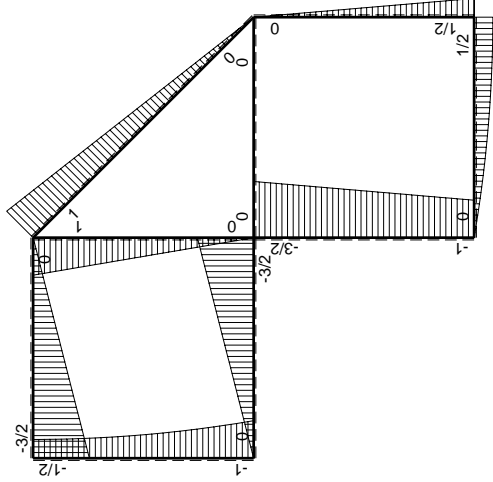
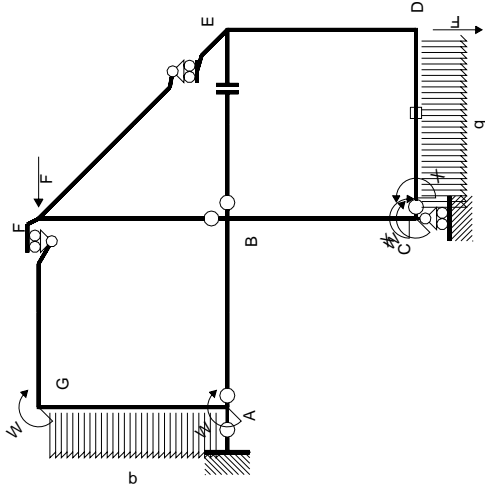

M_0 flessione da carichi assegnati

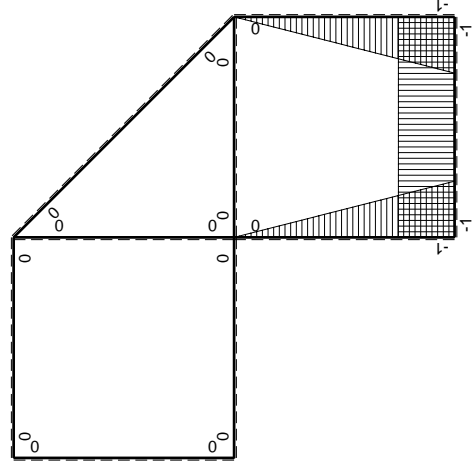

M_x flessione da iperstatica $X=1$

Quadro contribuiti PLV per iperstatica $X=W_{cd}$

\rightarrow	$M_x(x)$	$M_0(x)$	$M_x M_0$	$M_x M_x$	$\int M_x M_0 / EJ dx$	$\int X M_x M_x / EJ dx$
AB b	0	-3/2Fx	0	0	0	0
BA b	0	3/2Fb-3/2Fx	0	0	0	0
BC b	-x/b	-3/2Fb+1/2Fx	3/2Fx-1/2Fx ² /b	x ² /b ²	7/12Fb ² /EJ	1/3Xb/EJ
CB b	1-x/b	Fb+1/2Fx	Fb-1/2Fx-1/2Fx ² /b	1-2x/b+x ² /b ²		
CD b	-1	Fx-1/2qx ²	-Fx+1/2Fx ² /b	1	-1/3Fb ² /EJ	Xb/EJ
DC b	1	-1/2Fb+1/2qx ²	-1/2Fb+1/2Fx ² /b	1		
DE b	-1+x/b	1/2Fb-1/2Fx	-1/2Fb+Fx-1/2Fx ² /b	1-2x/b+x ² /b ²	-1/6Fb ² /EJ	1/3Xb/EJ
ED b	x/b	-1/2Fx	-1/2Fx ² /b	x ² /b ²		
EF $\sqrt{2}b$	0	$\sqrt{2}2Fx$	0	0	0	0
FG b	0	-3/2Fx	0	0	0	0
GF b	0	3/2Fb-3/2Fx	0	0	0	0
GA b	0	-1/2Fb-1/2qx ²	0	0	0	0
AG b	0	Fb-Fx+1/2qx ²	0	0	0	0
FB b	0	Fb-Fx	0	0	0	0
BF b	0	-Fx	0	0	0	0
BE b	0	0	0	0	0	0
EB b	0	0	0	0	0	0
CD	elongazione asta $N_{1,cd} \epsilon_{cd} L_{cd}$				-Fb ² /EJ	
	totali				-11/12Fb ² /EJ	5/3Xb/EJ
	iperstatica $X=W_{cd}$				11/20Fb	

Sviluppi di calcolo iperstatica

$$L_{BC}^{xx} = \int_0^b (x^2/b^2) 1/EJ dx = [1/3 x^3/b^2]_0^b 1/EJ$$

$$= (1/3 b) 1/EJ = 1/3 b/EJ$$

$$L_{CB}^{xx} = \int_0^b (1 - 2x/b + x^2/b^2) 1/EJ dx = [x - x^2/b + 1/3 x^3/b^2]_0^b 1/EJ$$

$$= (b - b + 1/3 b) 1/EJ = 1/3 b/EJ$$

$$L_{CD}^{xx} = \int_0^b (1) 1/EJ dx = [x]_0^b 1/EJ$$

$$= (b) 1/EJ = b/EJ$$

$$L_{DC}^{xx} = \int_0^b (1) 1/EJ dx = [x]_0^b 1/EJ$$

$$= (b) 1/EJ = b/EJ$$

$$L_{DE}^{xx} = \int_0^b (1 - 2x/b + x^2/b^2) 1/EJ dx = [x - x^2/b + 1/3 x^3/b^2]_0^b 1/EJ$$

$$= (b - b + 1/3 b) 1/EJ = 1/3 b/EJ$$

$$L_{ED}^{xx} = \int_0^b (x^2/b^2) 1/EJ dx = [1/3 x^3/b^2]_0^b 1/EJ$$

$$= (1/3 b) 1/EJ = 1/3 b/EJ$$

$$L_{BC}^{xo} = \int_0^b (3/2 x/b - 1/2 x^2/b^2) Fb 1/EJ dx = [3/4 x^2/b - 1/6 x^3/b^2]_0^b Fb 1/EJ$$

$$= (3/4 b - 1/6 b) Fb 1/EJ = 7/12 Fb^2/EJ$$

$$L_{CB}^{xo} = \int_0^b (1 - 1/2 x/b - 1/2 x^2/b^2) Fb 1/EJ dx = [x - 1/4 x^2/b - 1/6 x^3/b^2]_0^b Fb 1/EJ$$

$$= (b - 1/4 b - 1/6 b) Fb 1/EJ = 7/12 Fb^2/EJ$$

$$L_{CD}^{xo} = \int_0^b (-x/b + 1/2 x^2/b^2) Fb 1/EJ dx + 1 (-1) 1 Fb^2/EJ$$

$$= [-1/2 x^2/b + 1/6 x^3/b^2]_0^b Fb 1/EJ + 1 (-1) 1 Fb^2/EJ$$

$$= (-1/2 b + 1/6 b) Fb 1/EJ + 1 (-1) 1 Fb^2/EJ = -4/3 Fb^2/EJ$$

$$L_{DC}^{xo} = \int_0^b (-1/2 + 1/2 x^2/b^2) Fb 1/EJ dx + 1 (-1) 1 Fb^2/EJ$$

$$= [-1/2 x + 1/6 x^3/b^2]_0^b Fb 1/EJ + 1 (-1) 1 Fb^2/EJ$$

$$= (-1/2 b + 1/6 b) Fb 1/EJ + 1 (-1) 1 Fb^2/EJ = -4/3 Fb^2/EJ$$

$$L_{DE}^{xo} = \int_0^b (-1/2 + x/b - 1/2 x^2/b^2) Fb 1/EJ dx = [-1/2 x + 1/2 x^2/b - 1/6 x^3/b^2]_0^b Fb 1/EJ$$

$$= (-1/2 b + 1/2 b - 1/6 b) Fb 1/EJ = -1/6 Fb^2/EJ$$

$$L_{ED}^{xo} = \int_0^b (-1/2 x^2/b^2) Fb 1/EJ dx = [-1/6 x^3/b^2]_0^b Fb 1/EJ$$

$$= (-1/6 b) Fb 1/EJ = -1/6 Fb^2/EJ$$

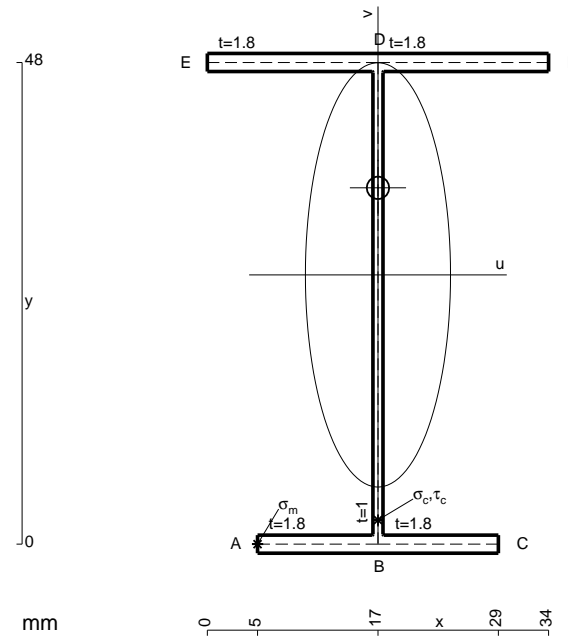

$A = 152.4 \text{ mm}^2$
 $J_u = 68126. \text{ mm}^4$
 $J_v = 7969. \text{ mm}^4$
 $J_t = 128.8 \text{ mm}^4$
 $y_o = 8.676 \text{ mm}$
 $y_g = 26.83 \text{ mm}$
 $N = -470. \text{ N}$
 $T_y = -705. \text{ N}$
 $M_x = -599250. \text{ Nmm}$
 $x_m = 5. \text{ mm}$
 $u_m = -12. \text{ mm}$
 $v_m = -26.83 \text{ mm}$
 $\sigma_m = N/A - Mv/J_u = -239.1 \text{ N/mm}^2$
 $x_c = 17. \text{ mm}$
 $v_c = -26.83 \text{ mm}$
 $\sigma_c = N/A - Mv/J_u = -239.1 \text{ N/mm}^2$
 $\tau_c = TS/tJ_u = 12. \text{ N/mm}^2$
 $\tau_g = TS/tJ_u = 12. \text{ N/mm}^2$
 $t_c = 470. \text{ mm}$
 $\sigma_o = \sqrt{\sigma^2 + 3\tau^2} = 240. \text{ N/mm}^2$

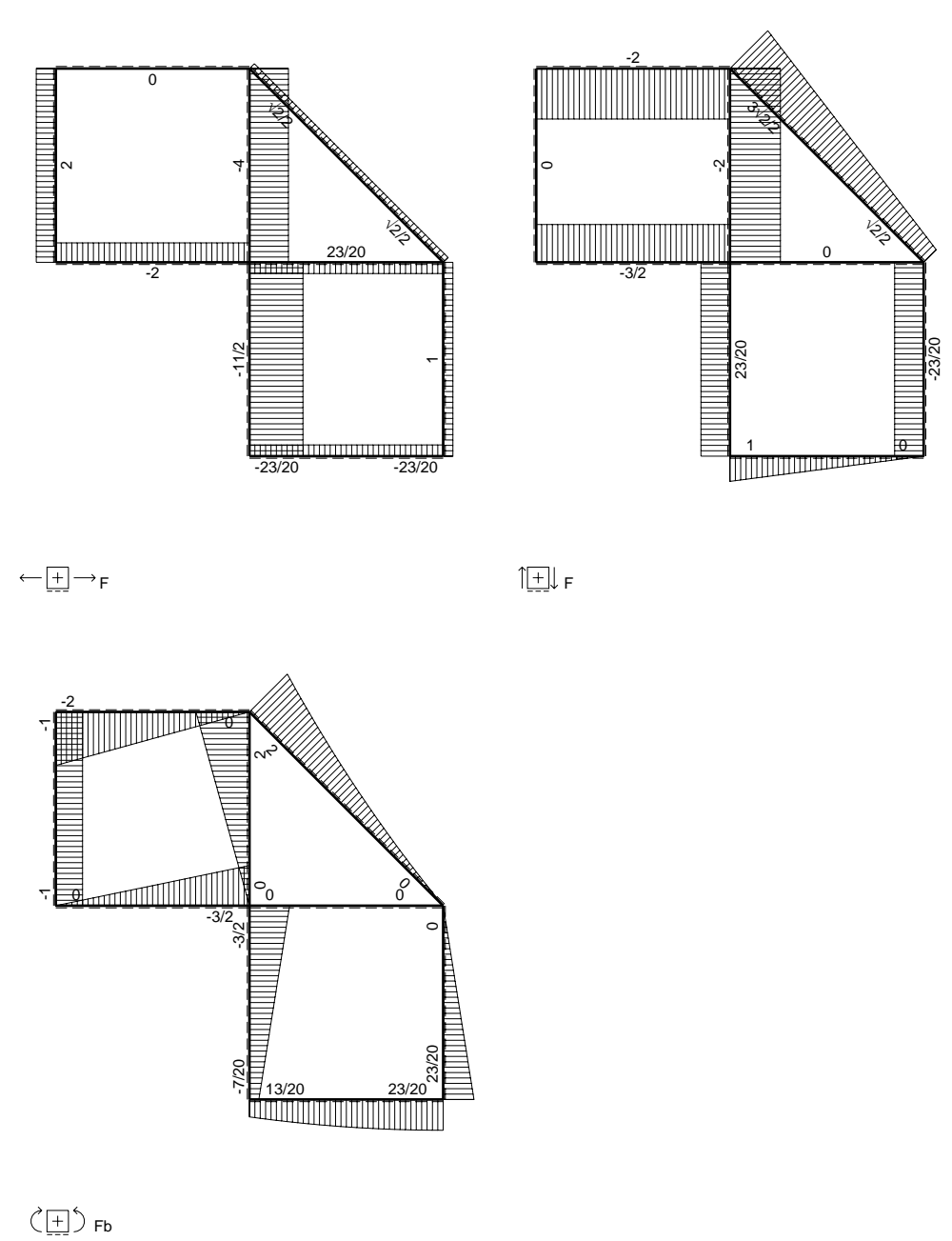
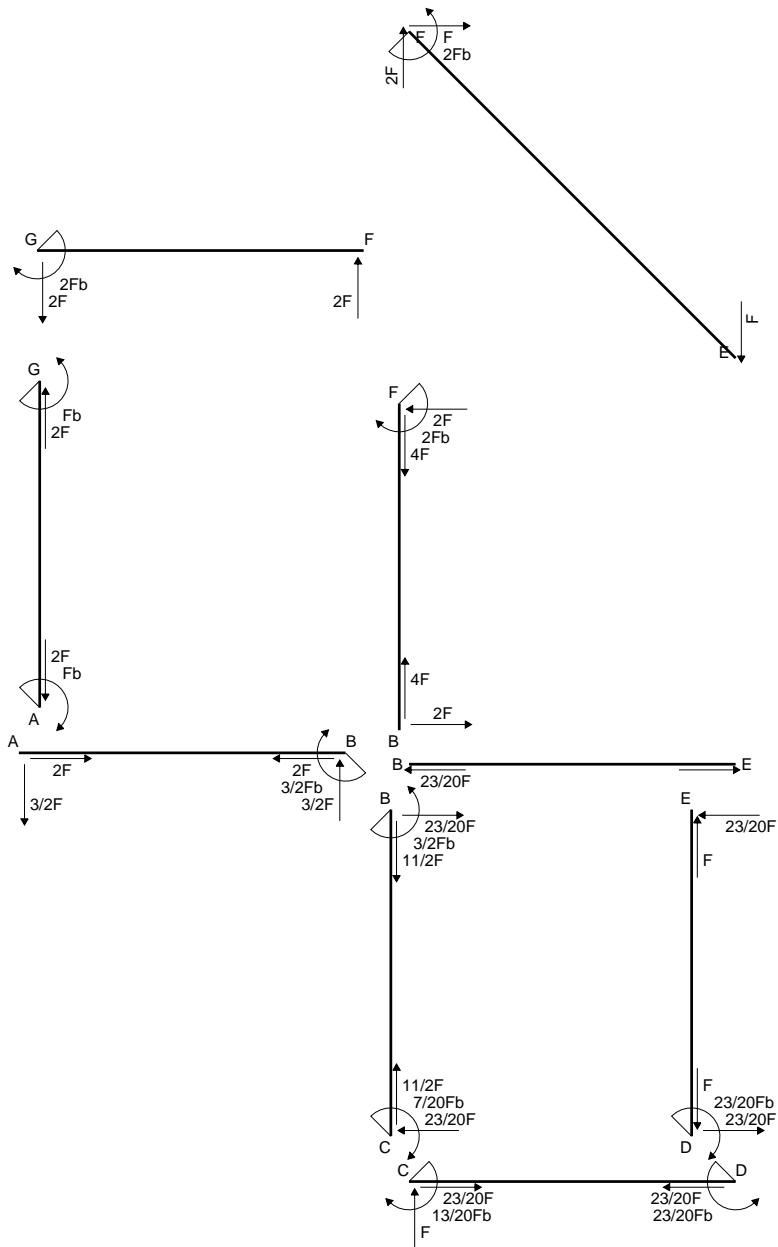

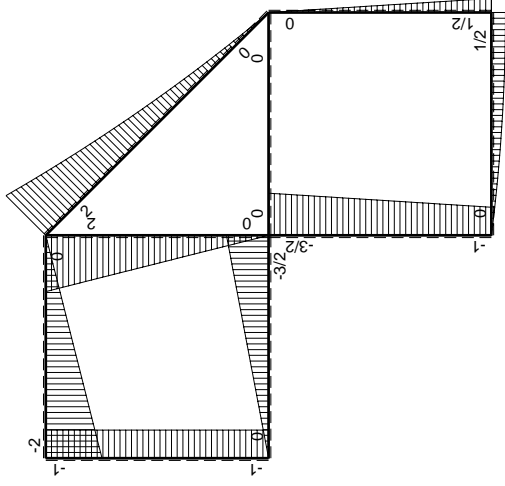
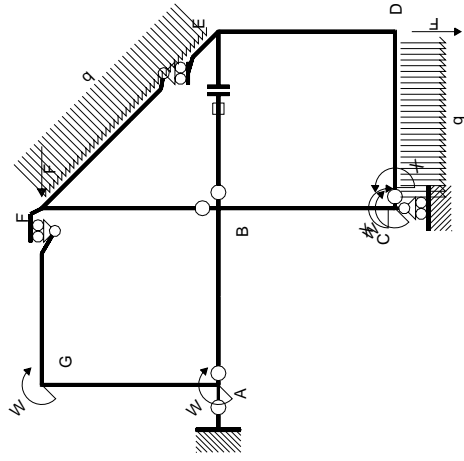

(\oplus) M_0 flessione da carichi assegnati

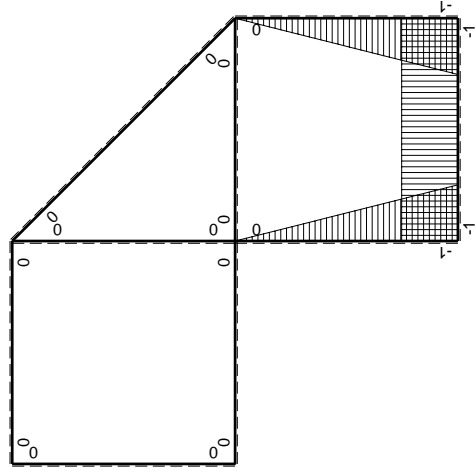

(\oplus) M_x flessione da iperstatica $X=1$

Quadro contribuiti PLV per iperstatica $X=W_{cd}$

\rightarrow	$M_x(x)$	$M_0(x)$	$M_x M_0$	$M_x M_x$	$\int M_x M_0 / EJ dx$	$\int M_x M_x / EJ dx$
AB b	0	-3/2Fx	0	0	0	0
BA b	0	3/2Fb-3/2Fx	0	0	0	0
BC b	-x/b	-3/2Fb+1/2Fx	3/2Fx-1/2Fx ² /b	x ² /b ²	7/12Fb ² /EJ	1/3Xb/EJ
CB b	1-x/b	Fb+1/2Fx	Fb-1/2Fx-1/2Fx ² /b	1-2x/b+x ² /b ²	-1/3Fb ² /EJ	Xb/EJ
CD b	-1	Fx-1/2qx ²	-Fx+1/2Fx ² /b	1	-1/6Fb ² /EJ	1/3Xb/EJ
DC b	1	-1/2Fb+1/2qx ²	-1/2Fb+1/2Fx ² /b	1	0	0
DE b	-1+x/b	1/2Fb-1/2Fx	-1/2Fb+Fx-1/2Fx ² /b	1-2x/b+x ² /b ²	-1/6Fb ² /EJ	1/3Xb/EJ
ED b	x/b	-1/2Fx	-1/2Fx ² /b	x ² /b ²	0	0
EF $\sqrt{2}b$	0	$\sqrt{2}/2Fx+1/2qx^2$	0	0	0	0
FG b	0	-2Fx	0	0	0	0
GF b	0	2Fb-2Fx	0	0	0	0
GA b	0	-Fb	0	0	0	0
AG b	0	Fb	0	0	0	0
FB b	0	2Fb-2Fx	0	0	0	0
BF b	0	-2Fx	0	0	0	0
BE b	0	0	0	0	0	0
EB b	0	0	0	0	0	0
BE	elongazione asta $N_{1, BE} \epsilon_{BE} L_{BE}$				Fb ² /EJ	
	totali				13/12Fb ² /EJ	5/3Xb/EJ
	iperstatica $X=W_{cd}$				-13/20Fb	

Sviluppi di calcolo iperstatica

$$L_{BC}^{xx} = \int_0^b (x^2/b^2) 1/EJ dx = [1/3 x^3/b^2]_0^b 1/EJ$$

$$= (1/3 b) 1/EJ = 1/3 b/EJ$$

$$L_{CB}^{xx} = \int_0^b (1 - 2x/b + x^2/b^2) 1/EJ dx = [x - x^2/b + 1/3 x^3/b^2]_0^b 1/EJ$$

$$= (b - b + 1/3 b) 1/EJ = 1/3 b/EJ$$

$$L_{CD}^{xx} = \int_0^b (1) 1/EJ dx = [x]_0^b 1/EJ$$

$$= (b) 1/EJ = b/EJ$$

$$L_{DC}^{xx} = \int_0^b (1) 1/EJ dx = [x]_0^b 1/EJ$$

$$= (b) 1/EJ = b/EJ$$

$$L_{DE}^{xx} = \int_0^b (1 - 2x/b + x^2/b^2) 1/EJ dx = [x - x^2/b + 1/3 x^3/b^2]_0^b 1/EJ$$

$$= (b - b + 1/3 b) 1/EJ = 1/3 b/EJ$$

$$L_{ED}^{xx} = \int_0^b (x^2/b^2) 1/EJ dx = [1/3 x^3/b^2]_0^b 1/EJ$$

$$= (1/3 b) 1/EJ = 1/3 b/EJ$$

$$L_{BC}^{xo} = \int_0^b (3/2 x/b - 1/2 x^2/b^2) Fb 1/EJ dx = [3/4 x^2/b - 1/6 x^3/b^2]_0^b Fb 1/EJ$$

$$= (3/4 b - 1/6 b) Fb 1/EJ = 7/12 Fb^2/EJ$$

$$L_{CB}^{xo} = \int_0^b (1 - 1/2 x/b - 1/2 x^2/b^2) Fb 1/EJ dx = [x - 1/4 x^2/b - 1/6 x^3/b^2]_0^b Fb 1/EJ$$

$$= (b - 1/4 b - 1/6 b) Fb 1/EJ = 7/12 Fb^2/EJ$$

$$L_{CD}^{xo} = \int_0^b (-x/b + 1/2 x^2/b^2) Fb 1/EJ dx = [-1/2 x^2/b + 1/6 x^3/b^2]_0^b Fb 1/EJ$$

$$= (-1/2 b + 1/6 b) Fb 1/EJ = -1/3 Fb^2/EJ$$

$$L_{DC}^{xo} = \int_0^b (-1/2 + 1/2 x^2/b^2) Fb 1/EJ dx = [-1/2 x + 1/6 x^3/b^2]_0^b Fb 1/EJ$$

$$= (-1/2 b + 1/6 b) Fb 1/EJ = -1/3 Fb^2/EJ$$

$$L_{DE}^{xo} = \int_0^b (-1/2 + x/b - 1/2 x^2/b^2) Fb 1/EJ dx = [-1/2 x + 1/2 x^2/b - 1/6 x^3/b^2]_0^b Fb 1/EJ$$

$$= (-1/2 b + 1/2 b - 1/6 b) Fb 1/EJ = -1/6 Fb^2/EJ$$

$$L_{ED}^{xo} = \int_0^b (-1/2 x^2/b^2) Fb 1/EJ dx = [-1/6 x^3/b^2]_0^b Fb 1/EJ$$

$$= (-1/6 b) Fb 1/EJ = -1/6 Fb^2/EJ$$

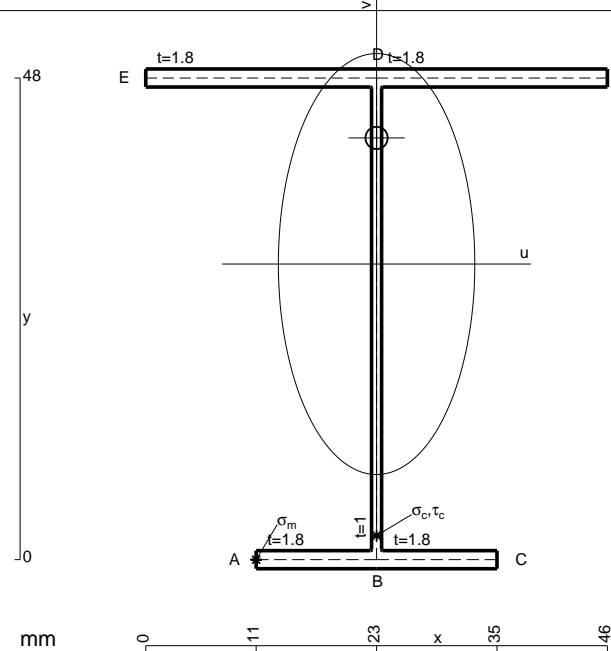

- A = 174. mm²
- J_u = 76601. mm⁴
- J_v = 16674. mm⁴
- J_t = 152.1 mm⁴
- y_o = 12.57 mm
- y_g = 29.46 mm
- N = 403.1 N
- T_y = 1209. N
- M_x = 513000. Nmm
- x_m = 11. mm
- u_m = -12. mm
- v_m = -29.46 mm
- σ_m = N/A-Mv/J_u = 199.6 N/mm²
- x_c = 23. mm
- v_c = -29.46 mm
- σ_c = N/A-Mv/J_u = 199.6 N/mm²
- τ_c = TS_t/tJ_u = 20.09 N/mm²
- τ_g = TS_t/tJ_u = 20.09 N/mm²
- t_c = 570. mm
- σ_o = √σ²+3τ² = 202.6 N/mm²

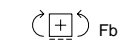
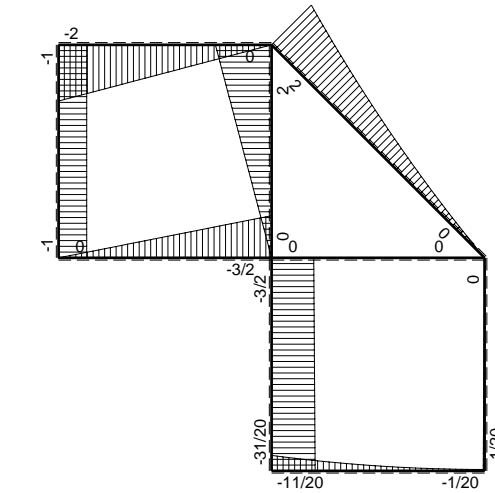
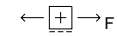
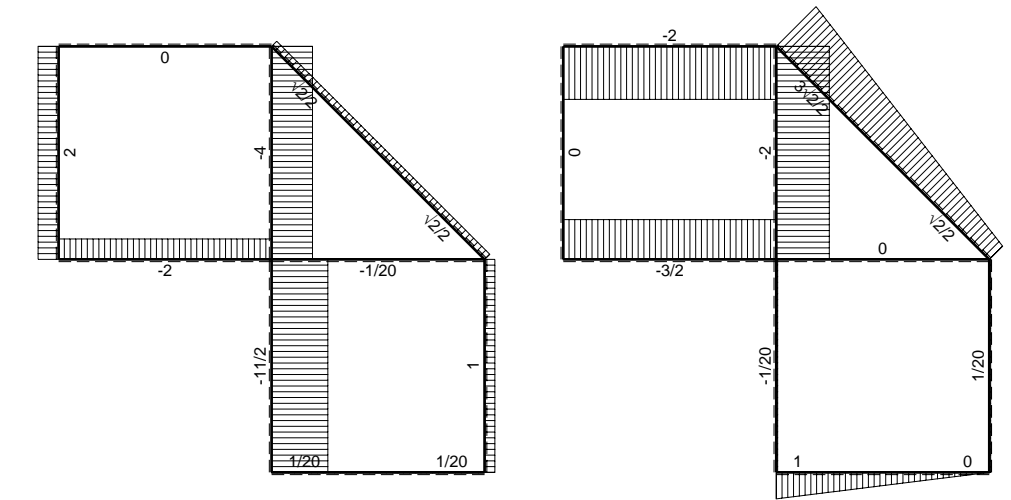
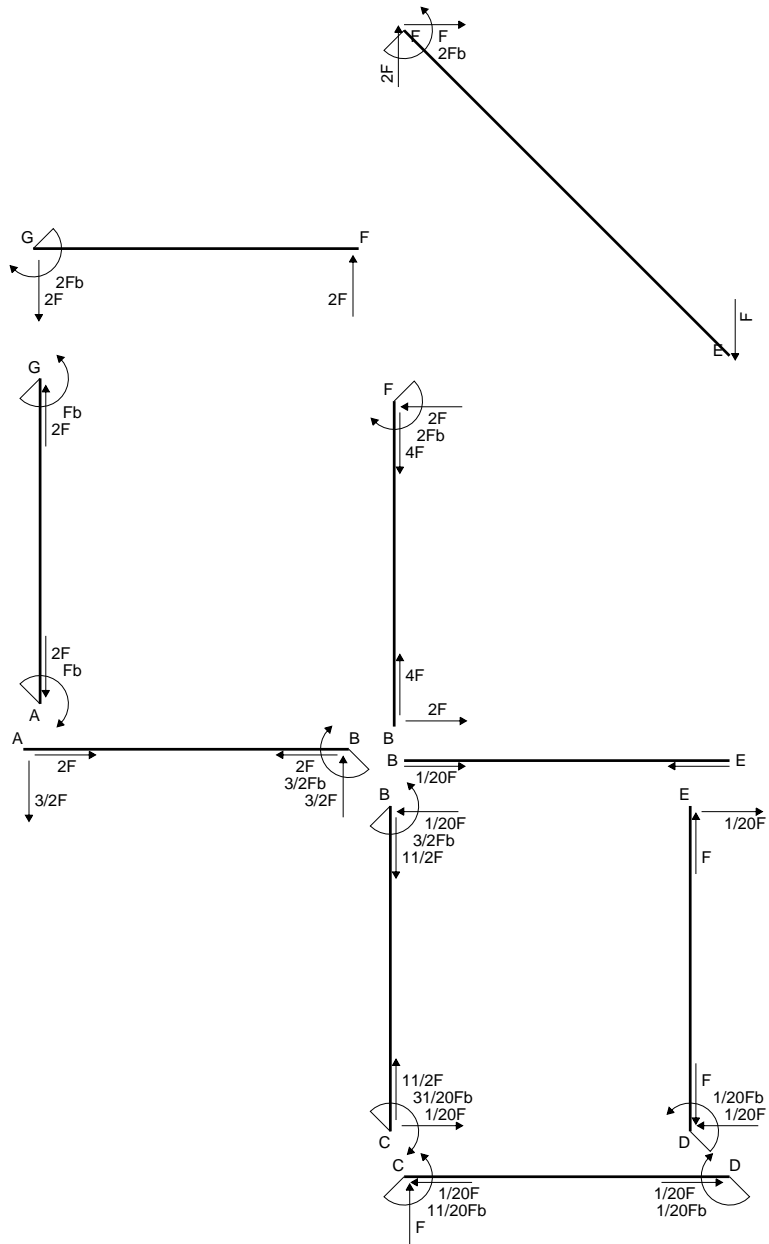

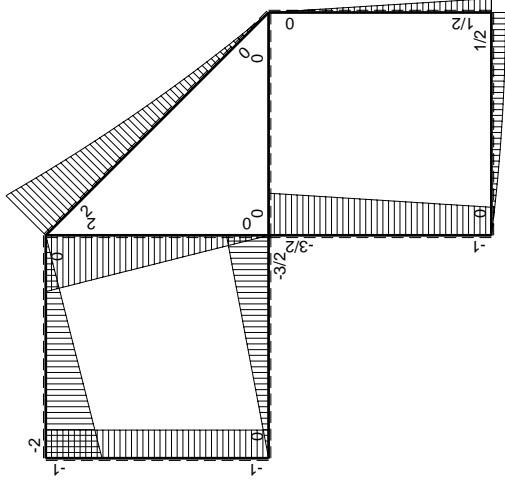
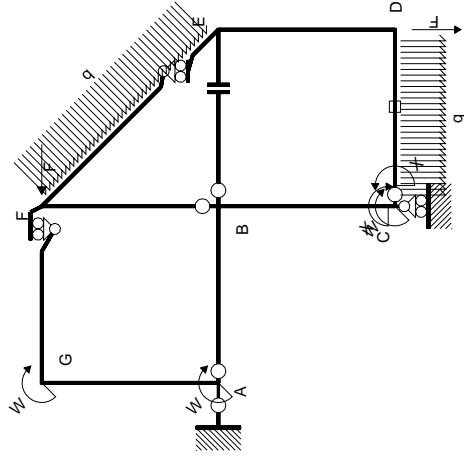

M_0 flessione da carichi assegnati

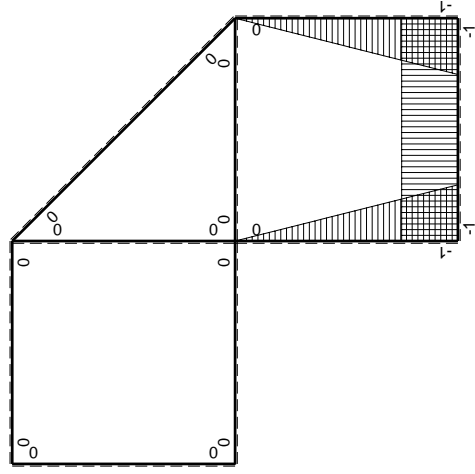

M_x flessione da iperstatica $X=1$

Quadro contribuiti PLV per iperstatica $X=W_{cd}$

\rightarrow	$M_x(x)$	$M_0(x)$	$M_x M_0$	$M_x M_x$	$\int M_x M_0 / EJ dx$	$\int M_x M_x / EJ dx$
AB b	0	-3/2Fx	0	0	0	0
BA b	0	3/2Fb-3/2Fx	0	0	0	0
BC b	-x/b	-3/2Fb+1/2Fx	3/2Fx-1/2Fx ² /b	x ² /b ²	7/12Fb ² /EJ	1/3Xb/EJ
CB b	1-x/b	Fb+1/2Fx	Fb-1/2Fx-1/2Fx ² /b	1-2x/b+x ² /b ²	-1/3Fb ² /EJ	Xb/EJ
CD b	-1	Fx-1/2qx ²	-Fx+1/2Fx ² /b	1	-1/6Fb ² /EJ	1/3Xb/EJ
DC b	1	-1/2Fb+1/2qx ²	-1/2Fb+1/2Fx ² /b	1	0	0
DE b	-1+x/b	1/2Fb-1/2Fx	-1/2Fb+Fx-1/2Fx ² /b	1-2x/b+x ² /b ²	-1/6Fb ² /EJ	1/3Xb/EJ
ED b	x/b	-1/2Fx	-1/2Fx ² /b	x ² /b ²	0	0
EF $\sqrt{2}b$	0	$\sqrt{2}/2Fx+1/2qx^2$	0	0	0	0
FG b	0	-2Fx	0	0	0	0
GF b	0	2Fb-2Fx	0	0	0	0
GA b	0	-Fb	0	0	0	0
AG b	0	Fb	0	0	0	0
FB b	0	2Fb-2Fx	0	0	0	0
BF b	0	-2Fx	0	0	0	0
BE b	0	0	0	0	0	0
EB b	0	0	0	0	0	0
CD	elongazione asta $N_{1,cd} \epsilon_{cd} L_{cd}$				-Fb ² /EJ	
	totali				-11/12Fb ² /EJ	5/3Xb/EJ
	iperstatica $X=W_{cd}$				11/20Fb	

Sviluppi di calcolo iperstatica

$$L_{BC}^{xx} = \int_0^b (x^2/b^2) 1/EJ dx = [1/3 x^3/b^2]_0^b 1/EJ$$

$$= (1/3 b) 1/EJ = 1/3 b/EJ$$

$$L_{CB}^{xx} = \int_0^b (1 - 2x/b + x^2/b^2) 1/EJ dx = [x - x^2/b + 1/3 x^3/b^2]_0^b 1/EJ$$

$$= (b - b + 1/3 b) 1/EJ = 1/3 b/EJ$$

$$L_{CD}^{xx} = \int_0^b (1) 1/EJ dx = [x]_0^b 1/EJ$$

$$= (b) 1/EJ = b/EJ$$

$$L_{DC}^{xx} = \int_0^b (1) 1/EJ dx = [x]_0^b 1/EJ$$

$$= (b) 1/EJ = b/EJ$$

$$L_{DE}^{xx} = \int_0^b (1 - 2x/b + x^2/b^2) 1/EJ dx = [x - x^2/b + 1/3 x^3/b^2]_0^b 1/EJ$$

$$= (b - b + 1/3 b) 1/EJ = 1/3 b/EJ$$

$$L_{ED}^{xx} = \int_0^b (x^2/b^2) 1/EJ dx = [1/3 x^3/b^2]_0^b 1/EJ$$

$$= (1/3 b) 1/EJ = 1/3 b/EJ$$

$$L_{BC}^{xo} = \int_0^b (3/2 x/b - 1/2 x^2/b^2) Fb 1/EJ dx = [3/4 x^2/b - 1/6 x^3/b^2]_0^b Fb 1/EJ$$

$$= (3/4 b - 1/6 b) Fb 1/EJ = 7/12 Fb^2/EJ$$

$$L_{CB}^{xo} = \int_0^b (1 - 1/2 x/b - 1/2 x^2/b^2) Fb 1/EJ dx = [x - 1/4 x^2/b - 1/6 x^3/b^2]_0^b Fb 1/EJ$$

$$= (b - 1/4 b - 1/6 b) Fb 1/EJ = 7/12 Fb^2/EJ$$

$$L_{CD}^{xo} = \int_0^b (-x/b + 1/2 x^2/b^2) Fb 1/EJ dx + 1 (-1) 1 Fb^2/EJ$$

$$= [-1/2 x^2/b + 1/6 x^3/b^2]_0^b Fb 1/EJ + 1 (-1) 1 Fb^2/EJ$$

$$= (-1/2 b + 1/6 b) Fb 1/EJ + 1 (-1) 1 Fb^2/EJ = -4/3 Fb^2/EJ$$

$$L_{DC}^{xo} = \int_0^b (-1/2 + 1/2 x^2/b^2) Fb 1/EJ dx + 1 (-1) 1 Fb^2/EJ$$

$$= [-1/2 x + 1/6 x^3/b^2]_0^b Fb 1/EJ + 1 (-1) 1 Fb^2/EJ$$

$$= (-1/2 b + 1/6 b) Fb 1/EJ + 1 (-1) 1 Fb^2/EJ = -4/3 Fb^2/EJ$$

$$L_{DE}^{xo} = \int_0^b (-1/2 + x/b - 1/2 x^2/b^2) Fb 1/EJ dx = [-1/2 x + 1/2 x^2/b - 1/6 x^3/b^2]_0^b Fb 1/EJ$$

$$= (-1/2 b + 1/2 b - 1/6 b) Fb 1/EJ = -1/6 Fb^2/EJ$$

$$L_{ED}^{xo} = \int_0^b (-1/2 x^2/b^2) Fb 1/EJ dx = [-1/6 x^3/b^2]_0^b Fb 1/EJ$$

$$= (-1/6 b) Fb 1/EJ = -1/6 Fb^2/EJ$$

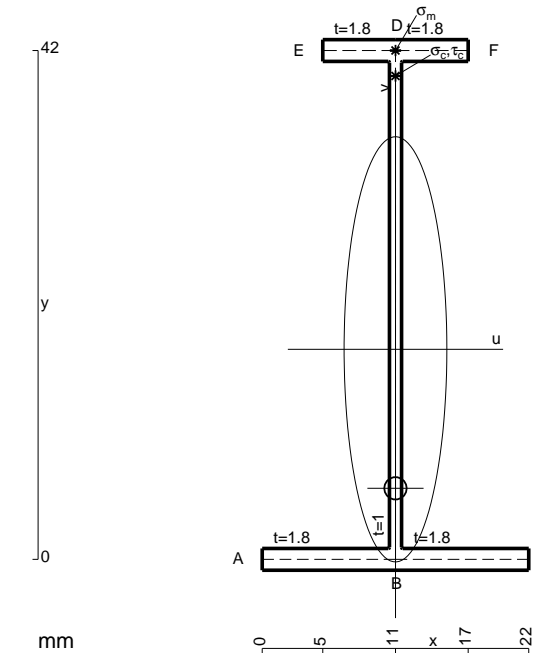

- A = 103.2 mm²
- J_u = 31779. mm⁴
- J_v = 1856. mm⁴
- J_t = 80.1 mm⁴
- y_o = -11.47 mm
- y_g = 17.34 mm
- N = -1160. N
- T_y = -580. N
- M_x = 255200. Nmm
- x_m = 11. mm
- y_m = 42. mm
- v_m = 24.66 mm
- σ_m = N/A-Mv/J_u = -209.3 N/mm²
- y_c = 2. mm
- u_c = -11. mm
- v_c = -15.34 mm
- σ_c = N/A-Mv/J_u = -209.3 N/mm²
- τ_c = TS¹/tJ_u = 9.723 N/mm²
- τ_g = TS¹/tJ_u = 9.723 N/mm²
- t_c = 290. mm
- σ_o = √σ²+3τ² = 210. N/mm²

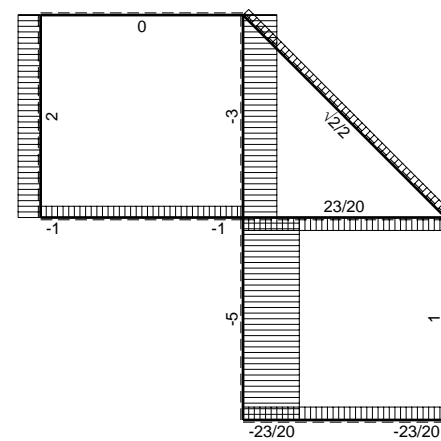
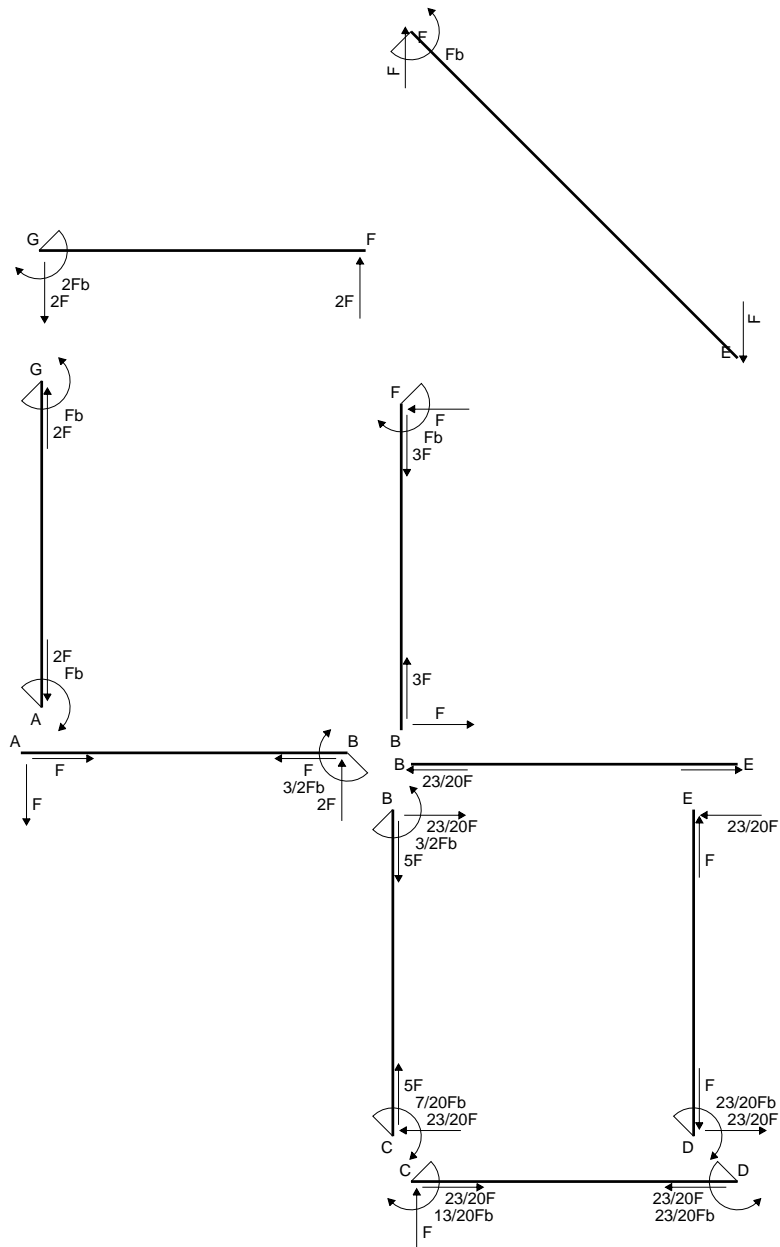

← ⊕ → F

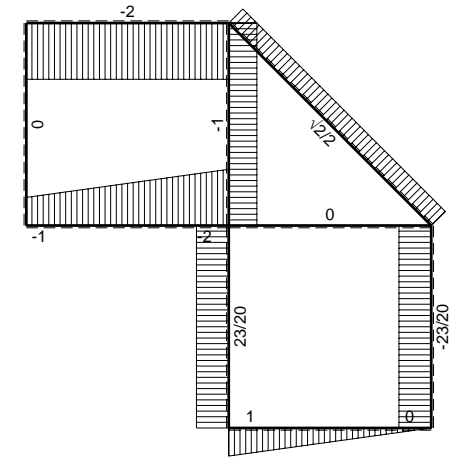

↑ ⊕ ↓ F

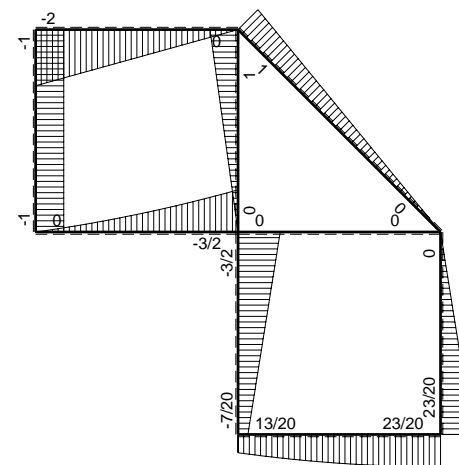

⊕ ⊖ Fb

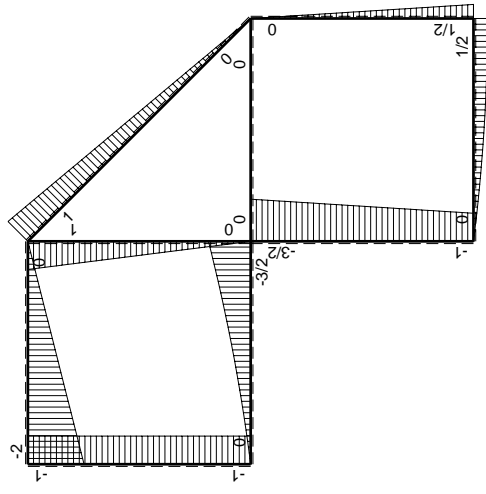
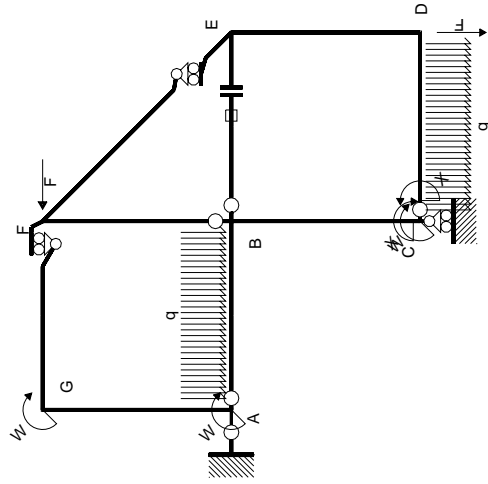

(\oplus) M_0 flessione da carichi assegnati

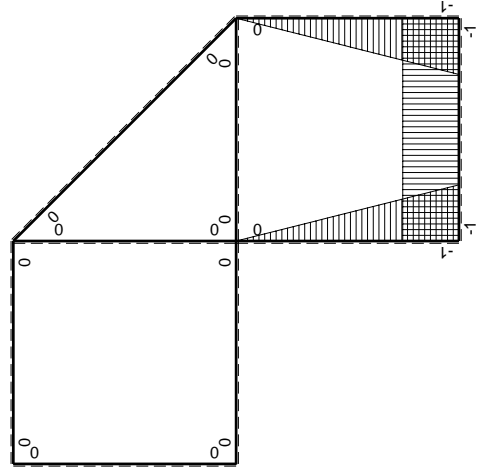

(\oplus) M_x flessione da iperstatica $X=1$

Quadro contribuiti PLV per iperstatica $X=W_{cd}$

\rightarrow	$M_x(x)$	$M_0(x)$	$M_x M_0$	$M_x M_x$	$\int M_x M_0 / EJ dx$	$\int M_x M_x / EJ dx$
AB b	0	$-Fx - 1/2qx^2$	0	0	0	0
BA b	0	$3/2Fb - 2Fx + 1/2qx^2$	0	0	0	0
BC b	$-x/b$	$-3/2Fb + 1/2Fx$	$3/2Fx - 1/2Fx^2/b$	x^2/b^2	$7/12Fb^2/EJ$	$1/3Xb/EJ$
CB b	$1-x/b$	$Fb + 1/2Fx$	$Fb - 1/2Fx - 1/2Fx^2/b$	$1 - 2x/b + x^2/b^2$	$-1/3Fb^2/EJ$	Xb/EJ
CD b	-1	$Fx - 1/2qx^2$	$-Fx + 1/2Fx^2/b$	1	$-1/3Fb^2/EJ$	Xb/EJ
DC b	1	$-1/2Fb + 1/2qx^2$	$-1/2Fb + 1/2Fx^2/b$	1	$-1/3Fb^2/EJ$	Xb/EJ
DE b	$-1+x/b$	$1/2Fb - 1/2Fx$	$-1/2Fb + Fx - 1/2Fx^2/b$	$1 - 2x/b + x^2/b^2$	$-1/6Fb^2/EJ$	$1/3Xb/EJ$
ED b	x/b	$-1/2Fx$	$-1/2Fx^2/b$	x^2/b^2	$-1/6Fb^2/EJ$	$1/3Xb/EJ$
EF $\sqrt{2}b$	0	$\sqrt{2}/2Fx$	0	0	0	0
FG b	0	$-2Fx$	0	0	0	0
GF b	0	$2Fb - 2Fx$	0	0	0	0
GA b	0	$-Fb$	0	0	0	0
AG b	0	Fb	0	0	0	0
FB b	0	$Fb - Fx$	0	0	0	0
BF b	0	$-Fx$	0	0	0	0
BE b	0	0	0	0	0	0
EB b	0	0	0	0	0	0
BE	elongazione asta $N_{1, BE}^E - L_{BE}^{BE}$				Fb^2/EJ	
	totali				$13/12Fb^2/EJ$	$5/3Xb/EJ$
	iperstatica $X=W_{cd}$				$-13/20Fb$	

Sviluppi di calcolo iperstatica

$$L_{BC}^{xx} = \int_0^b (x^2/b^2) 1/EJ dx = [1/3 x^3/b^2]_0^b 1/EJ$$

$$= (1/3 b) 1/EJ = 1/3 b/EJ$$

$$L_{CB}^{xx} = \int_0^b (1 - 2x/b + x^2/b^2) 1/EJ dx = [x - x^2/b + 1/3 x^3/b^2]_0^b 1/EJ$$

$$= (b - b + 1/3 b) 1/EJ = 1/3 b/EJ$$

$$L_{CD}^{xx} = \int_0^b (1) 1/EJ dx = [x]_0^b 1/EJ$$

$$= (b) 1/EJ = b/EJ$$

$$L_{DC}^{xx} = \int_0^b (1) 1/EJ dx = [x]_0^b 1/EJ$$

$$= (b) 1/EJ = b/EJ$$

$$L_{DE}^{xx} = \int_0^b (1 - 2x/b + x^2/b^2) 1/EJ dx = [x - x^2/b + 1/3 x^3/b^2]_0^b 1/EJ$$

$$= (b - b + 1/3 b) 1/EJ = 1/3 b/EJ$$

$$L_{ED}^{xx} = \int_0^b (x^2/b^2) 1/EJ dx = [1/3 x^3/b^2]_0^b 1/EJ$$

$$= (1/3 b) 1/EJ = 1/3 b/EJ$$

$$L_{BC}^{x_0} = \int_0^b (3/2 x/b - 1/2 x^2/b^2) Fb 1/EJ dx = [3/4 x^2/b - 1/6 x^3/b^2]_0^b Fb 1/EJ$$

$$= (3/4 b - 1/6 b) Fb 1/EJ = 7/12 Fb^2/EJ$$

$$L_{CB}^{x_0} = \int_0^b (1 - 1/2 x/b - 1/2 x^2/b^2) Fb 1/EJ dx = [x - 1/4 x^2/b - 1/6 x^3/b^2]_0^b Fb 1/EJ$$

$$= (b - 1/4 b - 1/6 b) Fb 1/EJ = 7/12 Fb^2/EJ$$

$$L_{CD}^{x_0} = \int_0^b (-x/b + 1/2 x^2/b^2) Fb 1/EJ dx = [-1/2 x^2/b + 1/6 x^3/b^2]_0^b Fb 1/EJ$$

$$= (-1/2 b + 1/6 b) Fb 1/EJ = -1/3 Fb^2/EJ$$

$$L_{DC}^{x_0} = \int_0^b (-1/2 + 1/2 x^2/b^2) Fb 1/EJ dx = [-1/2 x + 1/6 x^3/b^2]_0^b Fb 1/EJ$$

$$= (-1/2 b + 1/6 b) Fb 1/EJ = -1/3 Fb^2/EJ$$

$$L_{DE}^{x_0} = \int_0^b (-1/2 + x/b - 1/2 x^2/b^2) Fb 1/EJ dx = [-1/2 x + 1/2 x^2/b - 1/6 x^3/b^2]_0^b Fb 1/EJ$$

$$= (-1/2 b + 1/2 b - 1/6 b) Fb 1/EJ = -1/6 Fb^2/EJ$$

$$L_{ED}^{x_0} = \int_0^b (-1/2 x^2/b^2) Fb 1/EJ dx = [-1/6 x^3/b^2]_0^b Fb 1/EJ$$

$$= (-1/6 b) Fb 1/EJ = -1/6 Fb^2/EJ$$

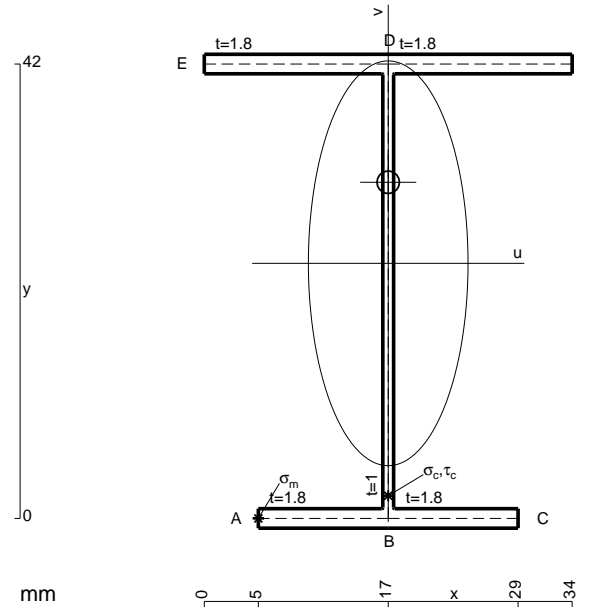

- A = 146.4 mm²
- J_u = 51238. mm⁴
- J_v = 7969. mm⁴
- J_i = 126.8 mm⁴
- y_o = 7.49 mm
- y_g = 23.58 mm
- T_y = -980. N
- M_x = -470400. Nmm
- x_m = 5. mm
- u_m = -12. mm
- v_m = -23.58 mm
- σ_m = -Mv/J_u = -216.5 N/mm²
- x_c = 17. mm
- v_c = -23.58 mm
- σ_c = -Mv/J_u = -216.5 N/mm²
- τ_c = TS'/tJ_u = 19.48 N/mm²
- τ_g = TS'/tJ_u = 19.48 N/mm²
- t_c = 490. mm
- σ_o = √σ²+3τ² = 219.1 N/mm²

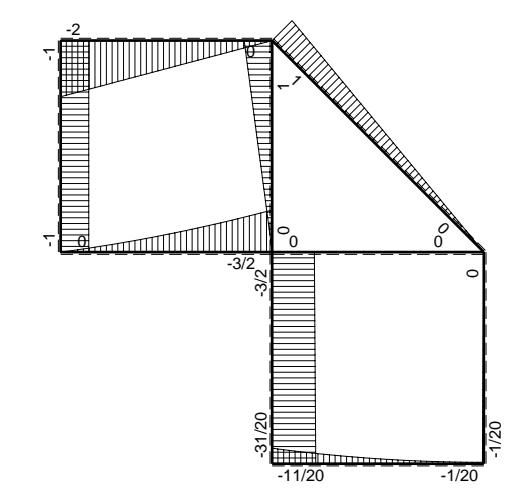
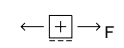
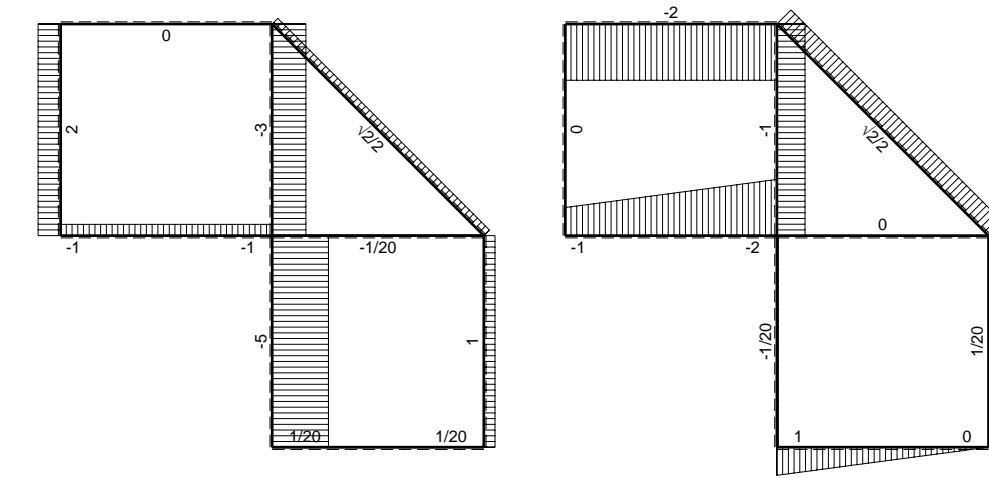
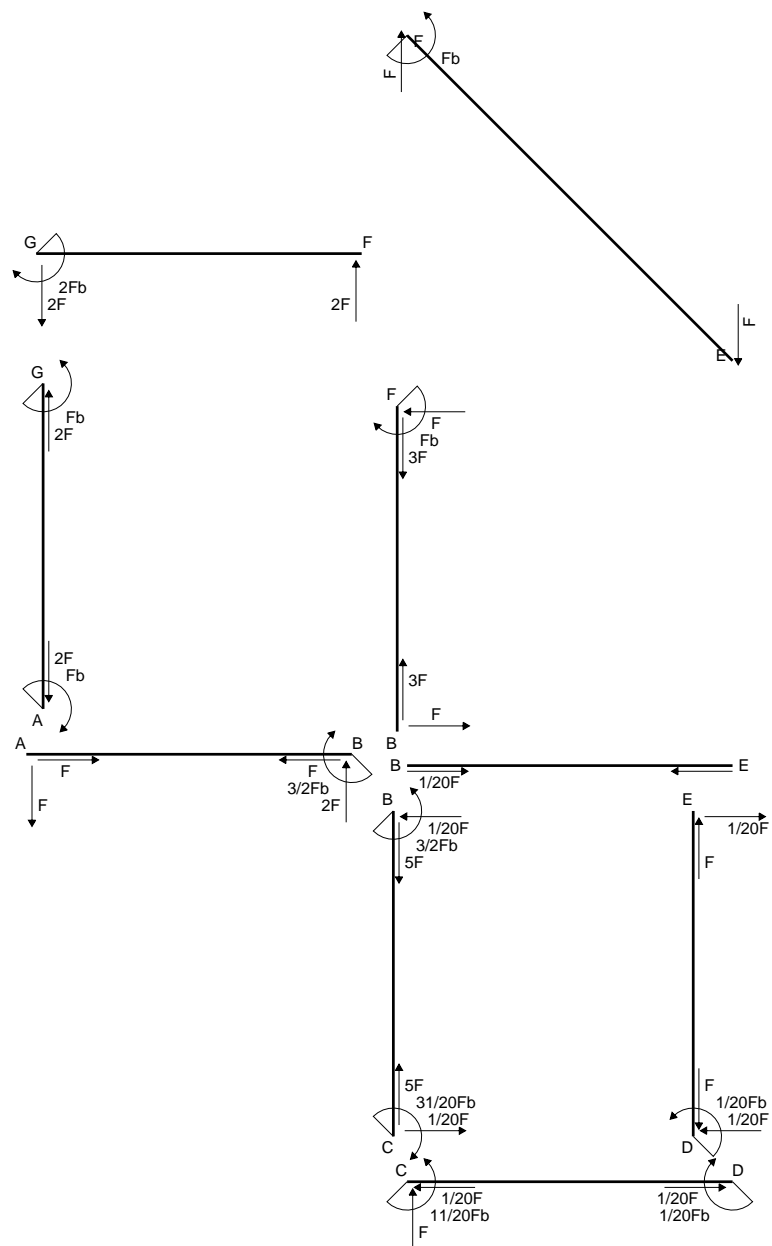

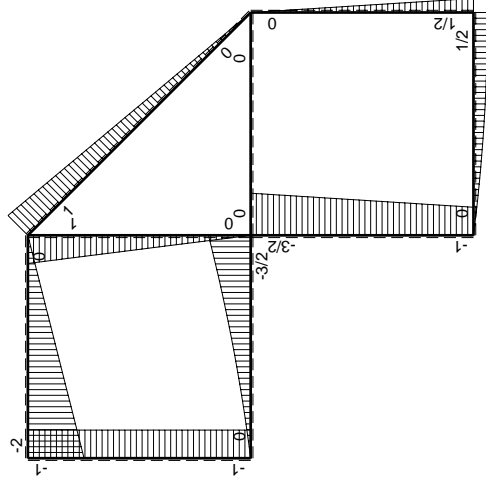
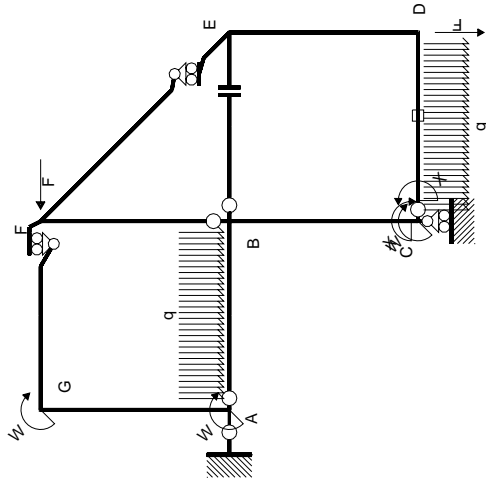

(\oplus) M_0 flessione da carichi assegnati

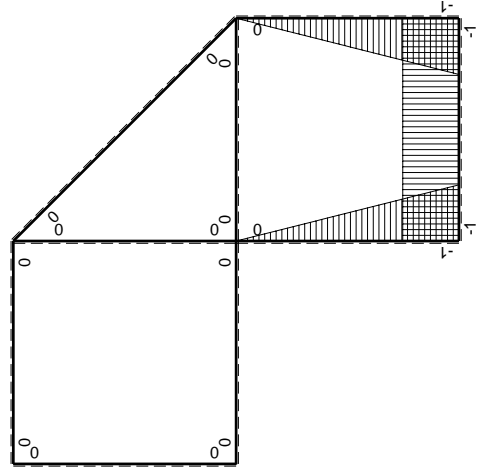

(\oplus) M_x flessione da iperstatica $X=1$

Quadro contribuiti PLV per iperstatica $X=W_{cd}$

\rightarrow	$M_x(x)$	$M_0(x)$	$M_x M_0$	$M_x M_x$	$\int M_x M_0 / EJ dx$	$\int X M_x M_x / EJ dx$
AB b	0	$-Fx - 1/2qx^2$	0	0	0	0
BA b	0	$3/2Fb - 2Fx + 1/2qx^2$	0	0	0	0
BC b	$-x/b$	$-3/2Fb + 1/2Fx$	$3/2Fx - 1/2Fx^2/b$	x^2/b^2	$7/12Fb^2/EJ$	$1/3Xb/EJ$
CB b	$1-x/b$	$Fb + 1/2Fx$	$Fb - 1/2Fx - 1/2Fx^2/b$	$1 - 2x/b + x^2/b^2$	$-1/3Fb^2/EJ$	Xb/EJ
CD b	-1	$Fx - 1/2qx^2$	$-Fx + 1/2Fx^2/b$	1	$-1/3Fb^2/EJ$	Xb/EJ
DC b	1	$-1/2Fb + 1/2qx^2$	$-1/2Fb + 1/2Fx^2/b$	1	$-1/3Fb^2/EJ$	Xb/EJ
DE b	$-1+x/b$	$1/2Fb - 1/2Fx$	$-1/2Fb + Fx - 1/2Fx^2/b$	$1 - 2x/b + x^2/b^2$	$-1/6Fb^2/EJ$	$1/3Xb/EJ$
ED b	x/b	$-1/2Fx$	$-1/2Fx^2/b$	x^2/b^2	$-1/6Fb^2/EJ$	$1/3Xb/EJ$
EF $\sqrt{2}b$	0	$\sqrt{2}/2Fx$	0	0	0	0
FG b	0	$-2Fx$	0	0	0	0
GF b	0	$2Fb - 2Fx$	0	0	0	0
GA b	0	$-Fb$	0	0	0	0
AG b	0	Fb	0	0	0	0
FB b	0	$Fb - Fx$	0	0	0	0
BF b	0	$-Fx$	0	0	0	0
BE b	0	0	0	0	0	0
EB b	0	0	0	0	0	0
CD	elongazione asta $N_{1,cd} \epsilon_{cd} L_{cd}$				$-Fb^2/EJ$	
	totali				$-11/12Fb^2/EJ$	$5/3Xb/EJ$
	iperstatica $X=W_{cd}$				$11/20Fb$	

Sviluppi di calcolo iperstatica

$$L_{BC}^{xx} = \int_0^b (x^2/b^2) 1/EJ dx = [1/3 x^3/b^2]_0^b 1/EJ$$

$$= (1/3 b) 1/EJ = 1/3 b/EJ$$

$$L_{CB}^{xx} = \int_0^b (1 - 2x/b + x^2/b^2) 1/EJ dx = [x - x^2/b + 1/3 x^3/b^2]_0^b 1/EJ$$

$$= (b - b + 1/3 b) 1/EJ = 1/3 b/EJ$$

$$L_{CD}^{xx} = \int_0^b (1) 1/EJ dx = [x]_0^b 1/EJ$$

$$= (b) 1/EJ = b/EJ$$

$$L_{DC}^{xx} = \int_0^b (1) 1/EJ dx = [x]_0^b 1/EJ$$

$$= (b) 1/EJ = b/EJ$$

$$L_{DE}^{xx} = \int_0^b (1 - 2x/b + x^2/b^2) 1/EJ dx = [x - x^2/b + 1/3 x^3/b^2]_0^b 1/EJ$$

$$= (b - b + 1/3 b) 1/EJ = 1/3 b/EJ$$

$$L_{ED}^{xx} = \int_0^b (x^2/b^2) 1/EJ dx = [1/3 x^3/b^2]_0^b 1/EJ$$

$$= (1/3 b) 1/EJ = 1/3 b/EJ$$

$$L_{BC}^{x_0} = \int_0^b (3/2 x/b - 1/2 x^2/b^2) Fb 1/EJ dx = [3/4 x^2/b - 1/6 x^3/b^2]_0^b Fb 1/EJ$$

$$= (3/4 b - 1/6 b) Fb 1/EJ = 7/12 Fb^2/EJ$$

$$L_{CB}^{x_0} = \int_0^b (1 - 1/2 x/b - 1/2 x^2/b^2) Fb 1/EJ dx = [x - 1/4 x^2/b - 1/6 x^3/b^2]_0^b Fb 1/EJ$$

$$= (b - 1/4 b - 1/6 b) Fb 1/EJ = 7/12 Fb^2/EJ$$

$$L_{CD}^{x_0} = \int_0^b (-x/b + 1/2 x^2/b^2) Fb 1/EJ dx + 1 (-1) 1 Fb^2/EJ$$

$$= [-1/2 x^2/b + 1/6 x^3/b^2]_0^b Fb 1/EJ + 1 (-1) 1 Fb^2/EJ$$

$$= (-1/2 b + 1/6 b) Fb 1/EJ + 1 (-1) 1 Fb^2/EJ = -4/3 Fb^2/EJ$$

$$L_{DC}^{x_0} = \int_0^b (-1/2 + 1/2 x^2/b^2) Fb 1/EJ dx + 1 (-1) 1 Fb^2/EJ$$

$$= [-1/2 x + 1/6 x^3/b^2]_0^b Fb 1/EJ + 1 (-1) 1 Fb^2/EJ$$

$$= (-1/2 b + 1/6 b) Fb 1/EJ + 1 (-1) 1 Fb^2/EJ = -4/3 Fb^2/EJ$$

$$L_{DE}^{x_0} = \int_0^b (-1/2 + x/b - 1/2 x^2/b^2) Fb 1/EJ dx = [-1/2 x + 1/2 x^2/b - 1/6 x^3/b^2]_0^b Fb 1/EJ$$

$$= (-1/2 b + 1/2 b - 1/6 b) Fb 1/EJ = -1/6 Fb^2/EJ$$

$$L_{ED}^{x_0} = \int_0^b (-1/2 x^2/b^2) Fb 1/EJ dx = [-1/6 x^3/b^2]_0^b Fb 1/EJ$$

$$= (-1/6 b) Fb 1/EJ = -1/6 Fb^2/EJ$$

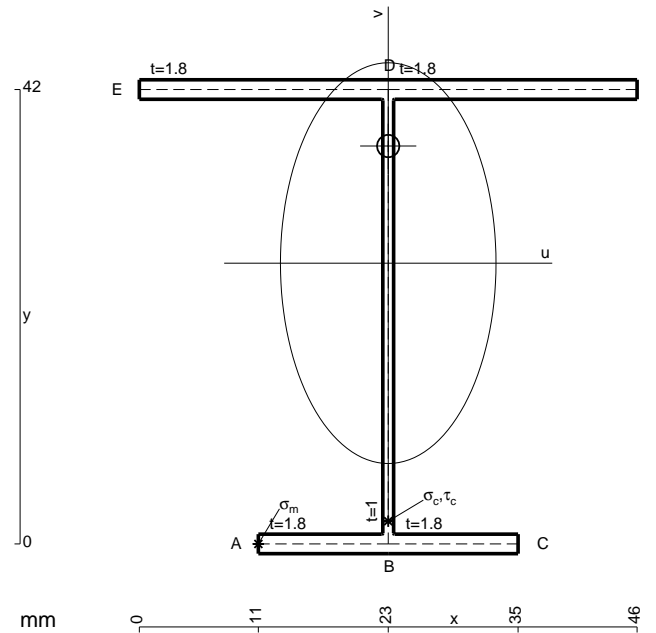

- A = 168. mm²
- J_u = 57624. mm⁴
- J_v = 16674. mm⁴
- J_t = 150.1 mm⁴
- y_o = 10.83 mm
- y_g = 25.95 mm
- T_y = -980. N
- M_x = -509600. Nmm
- x_m = 11. mm
- u_m = -12. mm
- v_m = -25.95 mm
- σ_m = -M_y/J_u = -229.5 N/mm²
- x_c = 23. mm
- v_c = -25.95 mm
- σ_c = -M_y/J_u = -229.5 N/mm²
- τ_c = T_S/t_{J_u} = 19.07 N/mm²
- τ_g = T_S/t_{J_u} = 19.07 N/mm²
- t_c = 490. mm
- σ_o = √σ²+3τ² = 231.9 N/mm²

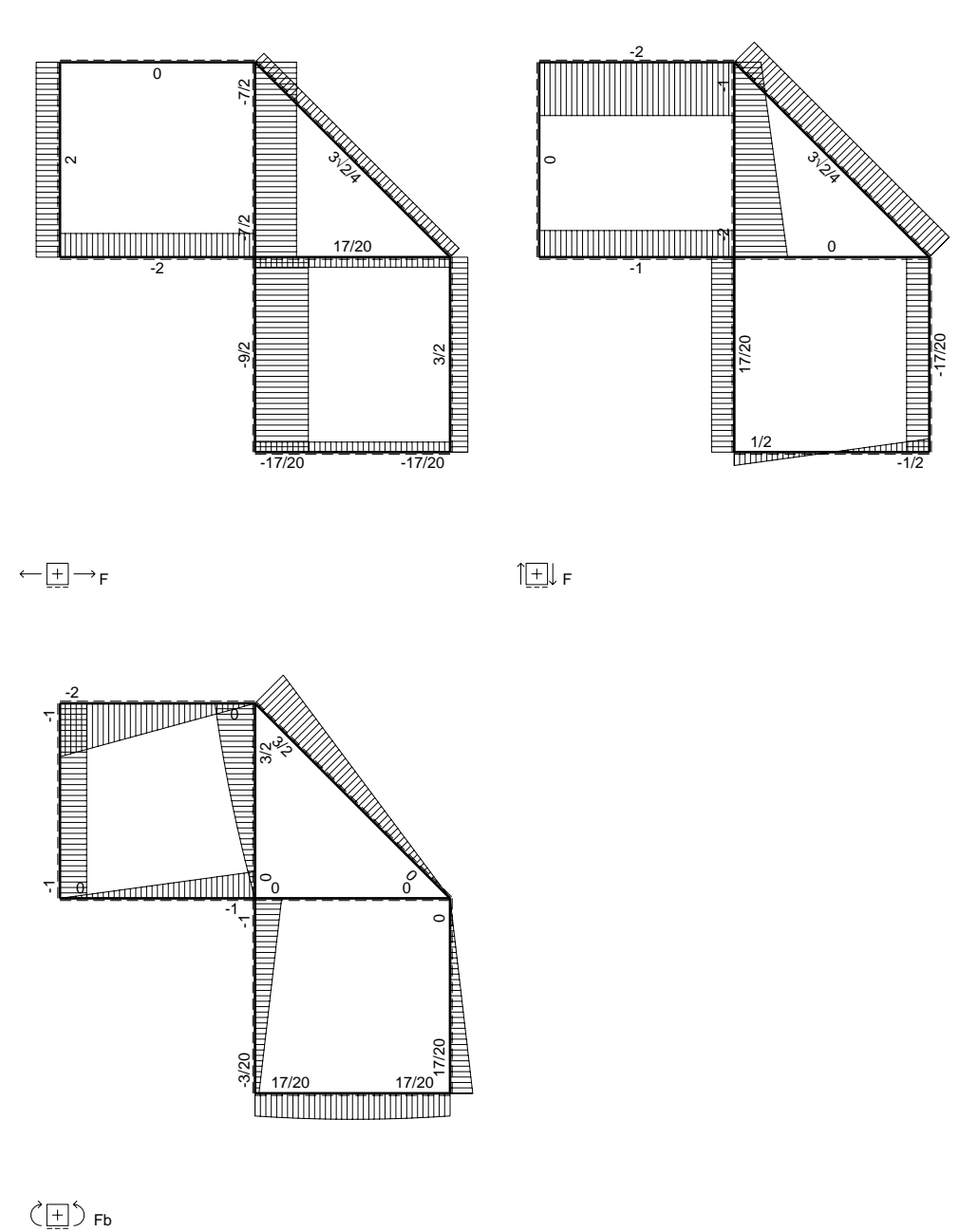
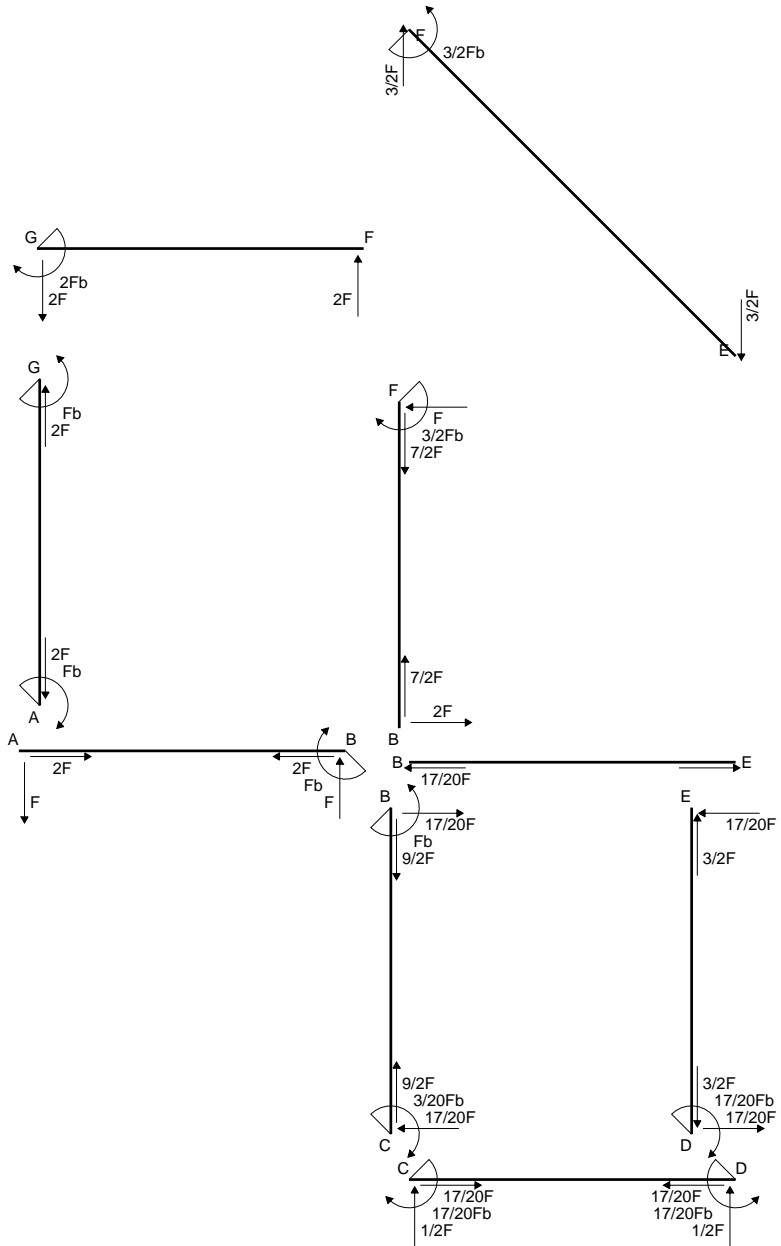

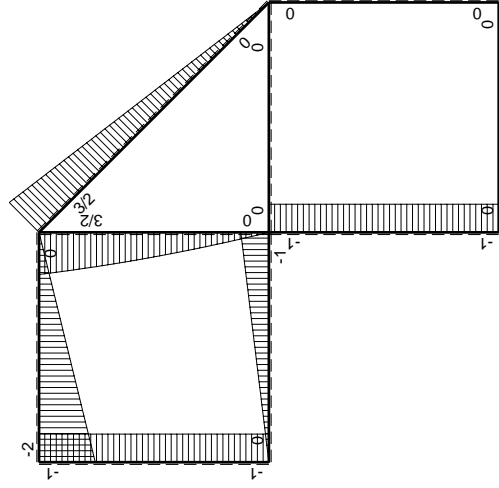
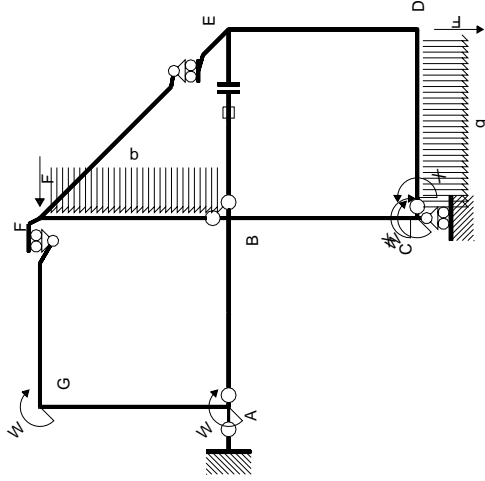

Schema di calcolo iperstatico

M_0 flessione da carichi assegnati

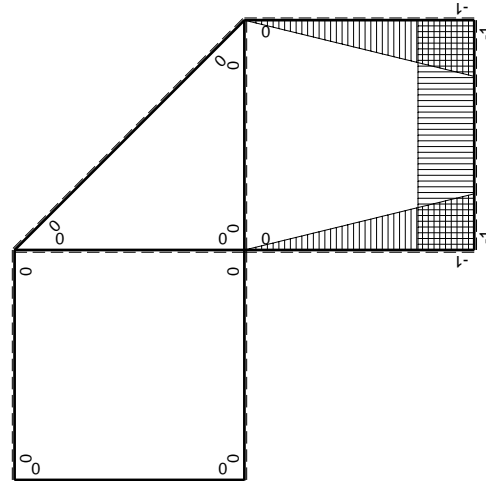

M_x flessione da iperstatica $X=1$

Quadro contribuiti PLV per iperstatica $X=W_{cd}$

\rightarrow	$M_x(x)$	$M_0(x)$	$M_x M_0$	$M_x M_x$	$\int M_x M_0 / EJ dx$	$\int X M_x M_x / EJ dx$
AB b	0	-Fx	0	0	0	0
BA b	0	Fb-Fx	0	0	0	0
BC b	-x/b	-Fb	Fx	x^2/b^2	$1/2Fb^2/EJ$	$1/3Xb/EJ$
CB b	1-x/b	Fb	Fb-Fx	$1-2x/b+x^2/b^2$	$1/2Fb^2/EJ$	$1/3Xb/EJ$
CD b	-1	$1/2Fx-1/2qx^2$	$-1/2Fx+1/2Fx^2/b$	1	$-1/12Fb^2/EJ$	Xb/EJ
DC b	1	$-1/2Fx+1/2qx^2$	$-1/2Fx+1/2Fx^2/b$	1	$-1/12Fb^2/EJ$	Xb/EJ
DE b	-1+x/b	0	0	$1-2x/b+x^2/b^2$	0	$1/3Xb/EJ$
ED b	x/b	0	0	x^2/b^2	0	$1/3Xb/EJ$
EF $\sqrt{2}b$	0	$3\sqrt{2}/4Fx$	0	0	0	0
FG b	0	-2Fx	0	0	0	0
GF b	0	2Fb-2Fx	0	0	0	0
GA b	0	-Fb	0	0	0	0
AG b	0	Fb	0	0	0	0
FB b	0	$3/2Fb-Fx-1/2qx^2$	0	0	0	0
BF b	0	$-2Fx+1/2qx^2$	0	0	0	0
BE b	0	0	0	0	0	0
EB b	0	0	0	0	0	0
BE	elongazione asta $N_{1, BE}^E - L_{BE}$			0	Fb^2/EJ	
	totali				$17/12Fb^2/EJ$	$5/3Xb/EJ$
	iperstatica $X=W_{cd}$				$-17/20Fb$	

Sviluppi di calcolo iperstatica

$$L_{BC}^{xx} = \int_0^b (x^2/b^2) 1/EJ dx = [1/3 x^3/b^2]_0^b 1/EJ$$

$$= (1/3 b) 1/EJ = 1/3 b/EJ$$

$$L_{CB}^{xx} = \int_0^b (1 - 2x/b + x^2/b^2) 1/EJ dx = [x - x^2/b + 1/3 x^3/b^2]_0^b 1/EJ$$

$$= (b - b + 1/3 b) 1/EJ = 1/3 b/EJ$$

$$L_{CD}^{xx} = \int_0^b (1) 1/EJ dx = [x]_0^b 1/EJ$$

$$= (b) 1/EJ = b/EJ$$

$$L_{DC}^{xx} = \int_0^b (1) 1/EJ dx = [x]_0^b 1/EJ$$

$$= (b) 1/EJ = b/EJ$$

$$L_{DE}^{xx} = \int_0^b (1 - 2x/b + x^2/b^2) 1/EJ dx = [x - x^2/b + 1/3 x^3/b^2]_0^b 1/EJ$$

$$= (b - b + 1/3 b) 1/EJ = 1/3 b/EJ$$

$$L_{ED}^{xx} = \int_0^b (x^2/b^2) 1/EJ dx = [1/3 x^3/b^2]_0^b 1/EJ$$

$$= (1/3 b) 1/EJ = 1/3 b/EJ$$

$$L_{BC}^{xo} = \int_0^b (x/b) Fb 1/EJ dx = [1/2 x^2/b]_0^b Fb 1/EJ$$

$$= (1/2 b) Fb 1/EJ = 1/2 Fb^2/EJ$$

$$L_{CB}^{xo} = \int_0^b (1 - x/b) Fb 1/EJ dx = [x - 1/2 x^2/b]_0^b Fb 1/EJ$$

$$= (b - 1/2 b) Fb 1/EJ = 1/2 Fb^2/EJ$$

$$L_{CD}^{xo} = \int_0^b (-1/2 x/b + 1/2 x^2/b^2) Fb 1/EJ dx = [-1/4 x^2/b + 1/6 x^3/b^2]_0^b Fb 1/EJ$$

$$= (-1/4 b + 1/6 b) Fb 1/EJ = -1/12 Fb^2/EJ$$

$$L_{DC}^{xo} = \int_0^b (-1/2 x/b + 1/2 x^2/b^2) Fb 1/EJ dx = [-1/4 x^2/b + 1/6 x^3/b^2]_0^b Fb 1/EJ$$

$$= (-1/4 b + 1/6 b) Fb 1/EJ = -1/12 Fb^2/EJ$$

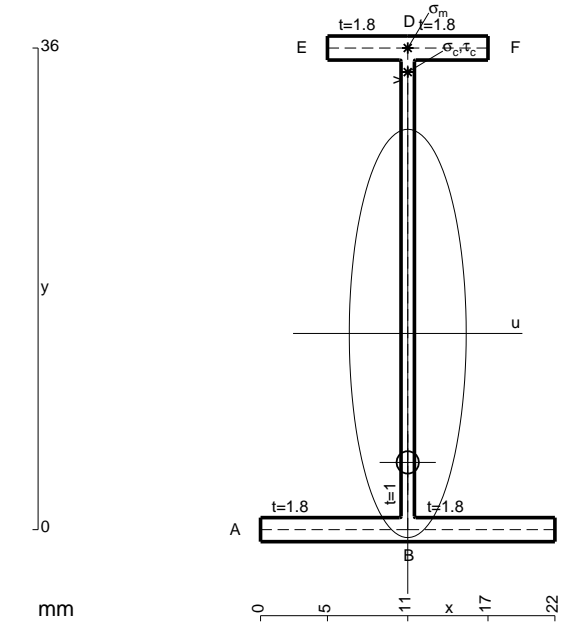

- A = 97.2 mm²
- J_u = 22637. mm⁴
- J_v = 1856. mm⁴
- J_i = 78.1 mm⁴
- y_o = -9.64 mm
- y_g = 14.67 mm
- T_y = -540. N
- M_x = -253800. Nmm
- x_m = 11. mm
- y_m = 36. mm
- v_m = 21.33 mm
- σ_m = -Mv/J_u = 239.2 N/mm²
- y_c = 2. mm
- u_c = -11. mm
- v_c = -12.67 mm
- σ_c = -Mv/J_u = 239.2 N/mm²
- τ_c = TS_i/tJ_u = 10.99 N/mm²
- τ_g = TS_i/tJ_u = 10.99 N/mm²
- t_c = 270. mm
- σ_o = √σ²+3τ² = 239.9 N/mm²

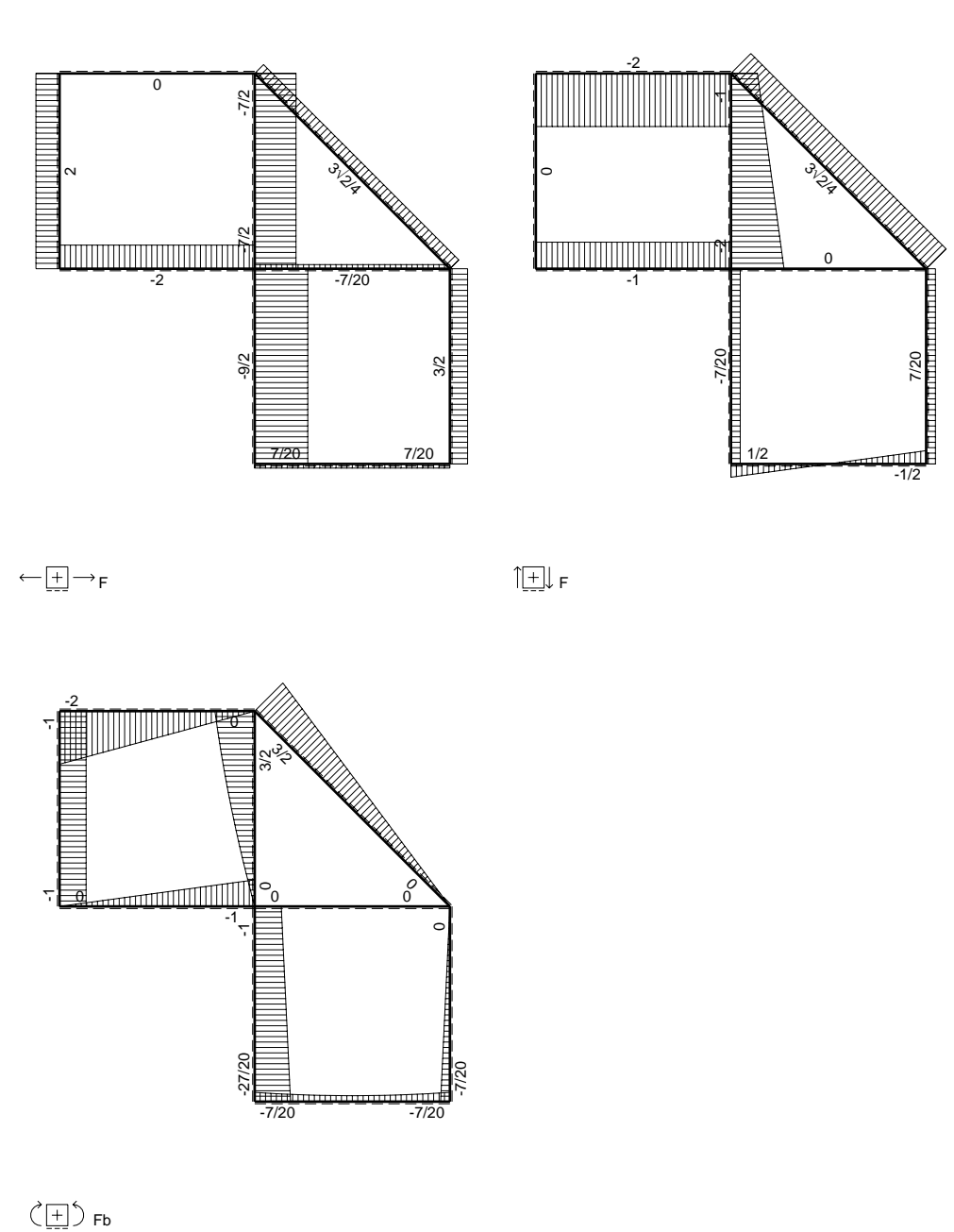
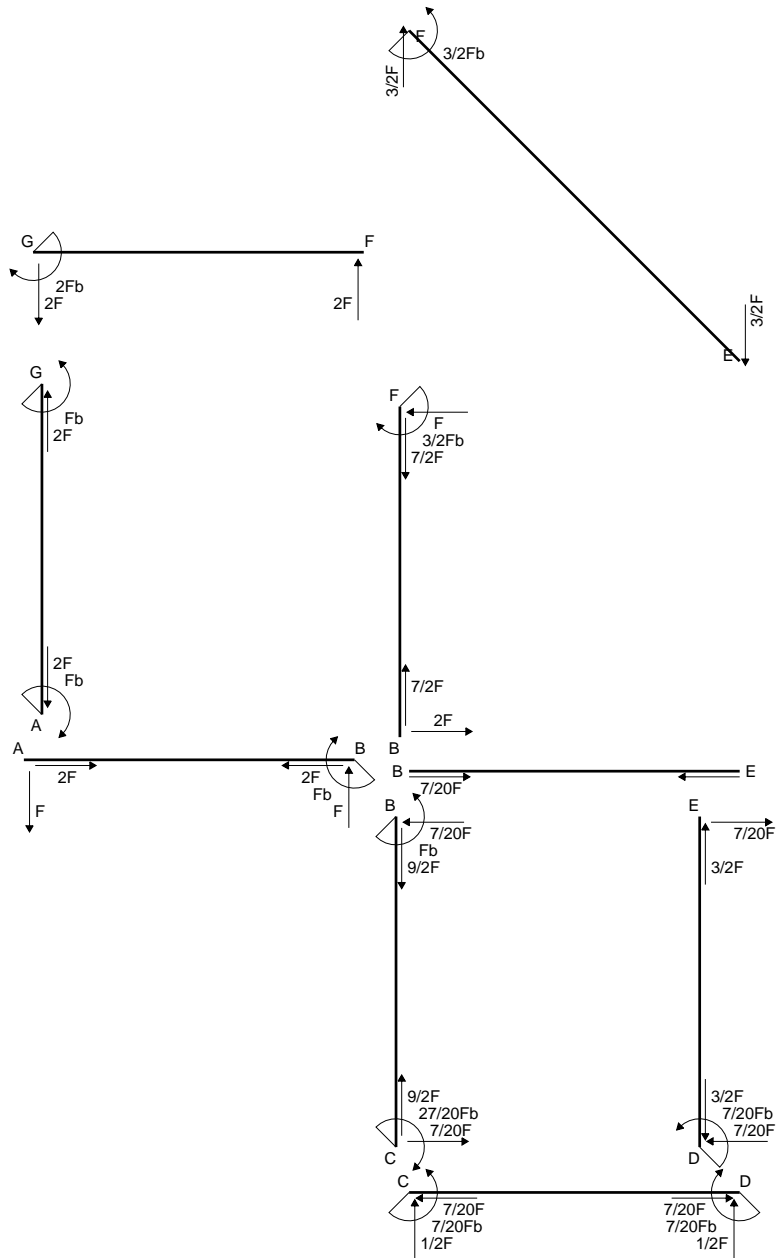

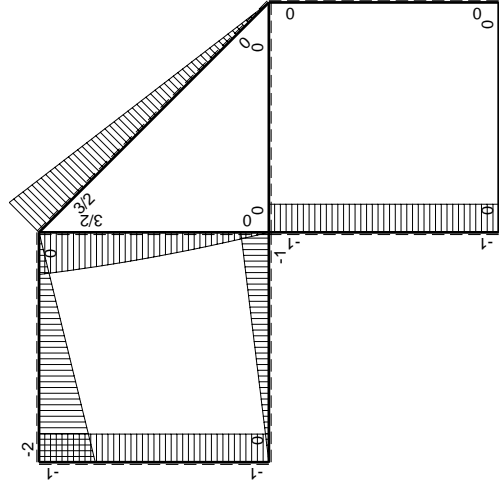
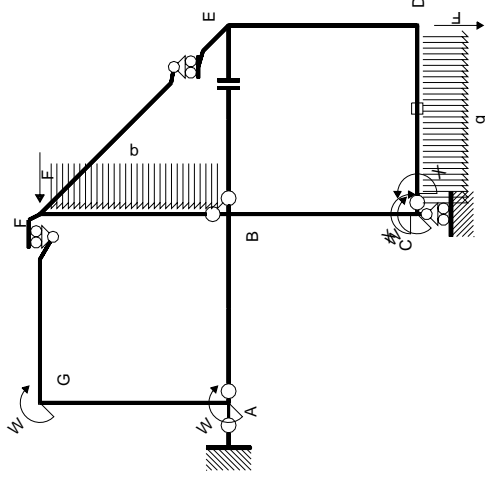

Schema di calcolo iperstatico

M_0 flessione da carichi assegnati

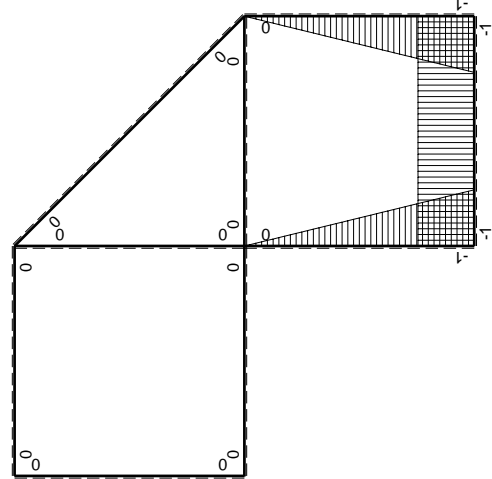

M_x flessione da iperstatica $X=1$

Quadro contribuiti PLV per iperstatica $X=W_{cd}$

→	$M_x(x)$	$M_0(x)$	$M_x M_0$	$M_x M_x$	$\int M_x M_0 / EJ dx$	$\int X M_x M_x / EJ dx$
AB b	0	-Fx	0	0	0	0
BA b	0	Fb-Fx	0	0	0	0
BC b	-x/b	-Fb	Fx	x^2/b^2	$1/2Fb^2/EJ$	$1/3Xb/EJ$
CB b	1-x/b	Fb	Fb-Fx	$1-2x/b+x^2/b^2$	$1/2Fb^2/EJ$	$1/3Xb/EJ$
CD b	-1	$1/2Fx-1/2qx^2$	$-1/2Fx+1/2Fx^2/b$	1	$-1/12Fb^2/EJ$	Xb/EJ
DC b	1	$-1/2Fx+1/2qx^2$	$-1/2Fx+1/2Fx^2/b$	1	$-1/12Fb^2/EJ$	Xb/EJ
DE b	-1+x/b	0	0	$1-2x/b+x^2/b^2$	0	$1/3Xb/EJ$
ED b	x/b	0	0	x^2/b^2	0	0
EF $\sqrt{2}b$	0	$3\sqrt{2}/4Fx$	0	0	0	0
FG b	0	-2Fx	0	0	0	0
GF b	0	2Fb-2Fx	0	0	0	0
GA b	0	-Fb	0	0	0	0
AG b	0	Fb	0	0	0	0
FB b	0	$3/2Fb-Fx-1/2qx^2$	0	0	0	0
BF b	0	$-2Fx+1/2qx^2$	0	0	0	0
BE b	0	0	0	0	0	0
EB b	0	0	0	0	0	0
CD	elongazione asta $N_{1,cd} \epsilon_{cd} L_{cd}$			0	$-Fb^2/EJ$	
	totali				$-7/12Fb^2/EJ$	$5/3Xb/EJ$
	iperstatica $X=W_{cd}$				$7/20Fb$	

Sviluppi di calcolo iperstatica

$$L_{BC}^{xx} = \int_0^b (x^2/b^2) 1/EJ dx = [1/3 x^3/b^2]_0^b 1/EJ$$

$$= (1/3 b) 1/EJ = 1/3 b/EJ$$

$$L_{CB}^{xx} = \int_0^b (1 - 2x/b + x^2/b^2) 1/EJ dx = [x - x^2/b + 1/3 x^3/b^2]_0^b 1/EJ$$

$$= (b - b + 1/3 b) 1/EJ = 1/3 b/EJ$$

$$L_{CD}^{xx} = \int_0^b (1) 1/EJ dx = [x]_0^b 1/EJ$$

$$= (b) 1/EJ = b/EJ$$

$$L_{DC}^{xx} = \int_0^b (1) 1/EJ dx = [x]_0^b 1/EJ$$

$$= (b) 1/EJ = b/EJ$$

$$L_{DE}^{xx} = \int_0^b (1 - 2x/b + x^2/b^2) 1/EJ dx = [x - x^2/b + 1/3 x^3/b^2]_0^b 1/EJ$$

$$= (b - b + 1/3 b) 1/EJ = 1/3 b/EJ$$

$$L_{ED}^{xx} = \int_0^b (x^2/b^2) 1/EJ dx = [1/3 x^3/b^2]_0^b 1/EJ$$

$$= (1/3 b) 1/EJ = 1/3 b/EJ$$

$$L_{BC}^{xo} = \int_0^b (x/b) Fb 1/EJ dx = [1/2 x^2/b]_0^b Fb 1/EJ$$

$$= (1/2 b) Fb 1/EJ = 1/2 Fb^2/EJ$$

$$L_{CB}^{xo} = \int_0^b (1 - x/b) Fb 1/EJ dx = [x - 1/2 x^2/b]_0^b Fb 1/EJ$$

$$= (b - 1/2 b) Fb 1/EJ = 1/2 Fb^2/EJ$$

$$L_{CD}^{xo} = \int_0^b (-1/2 x/b + 1/2 x^2/b^2) Fb 1/EJ dx + 1 (-1) 1 Fb^2/EJ$$

$$= [-1/4 x^2/b + 1/6 x^3/b^2]_0^b Fb 1/EJ + 1 (-1) 1 Fb^2/EJ$$

$$= (-1/4 b + 1/6 b) Fb 1/EJ + 1 (-1) 1 Fb^2/EJ = -13/12 Fb^2/EJ$$

$$L_{DC}^{xo} = \int_0^b (-1/2 x/b + 1/2 x^2/b^2) Fb 1/EJ dx + 1 (-1) 1 Fb^2/EJ$$

$$= [-1/4 x^2/b + 1/6 x^3/b^2]_0^b Fb 1/EJ + 1 (-1) 1 Fb^2/EJ$$

$$= (-1/4 b + 1/6 b) Fb 1/EJ + 1 (-1) 1 Fb^2/EJ = -13/12 Fb^2/EJ$$

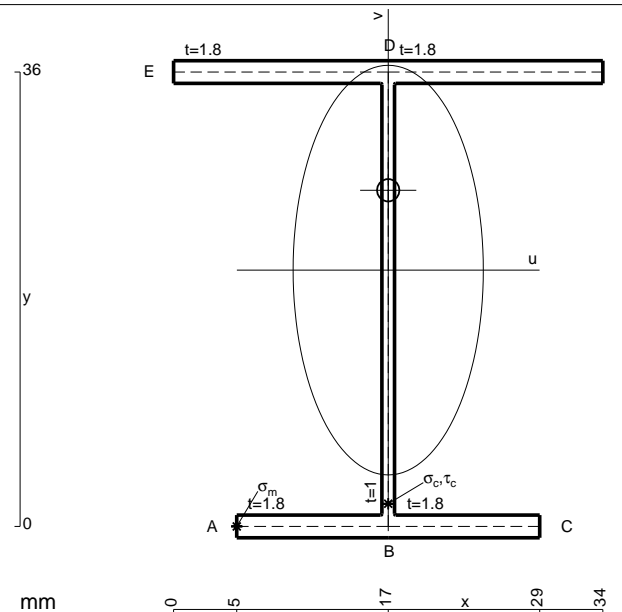

- A = 140.4 mm²
- J_u = 36966. mm⁴
- J_v = 7969. mm⁴
- J_i = 124.8 mm⁴
- y_o = 6.325 mm
- y_g = 20.31 mm
- T_y = -700. N
- M_x = -357000. Nmm
- x_m = 5. mm
- u_m = -12. mm
- v_m = -20.31 mm
- σ_m = -Mv/J_u = -196.1 N/mm²
- x_c = 17. mm
- v_c = -20.31 mm
- σ_c = -Mv/J_u = -196.1 N/mm²
- τ_c = TS'/tJ_u = 16.61 N/mm²
- τ_g = TS'/tJ_u = 16.61 N/mm²
- t_c = 350. mm
- σ_o = √σ²+3τ² = 198.2 N/mm²

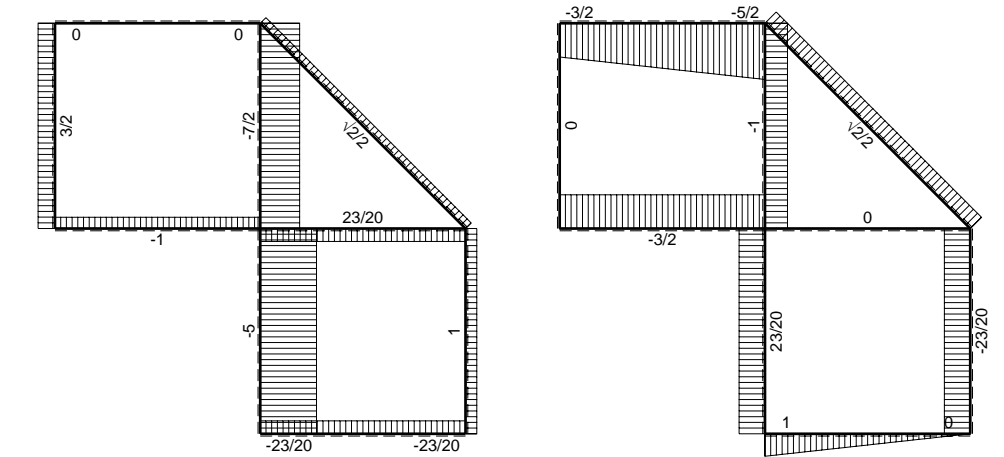
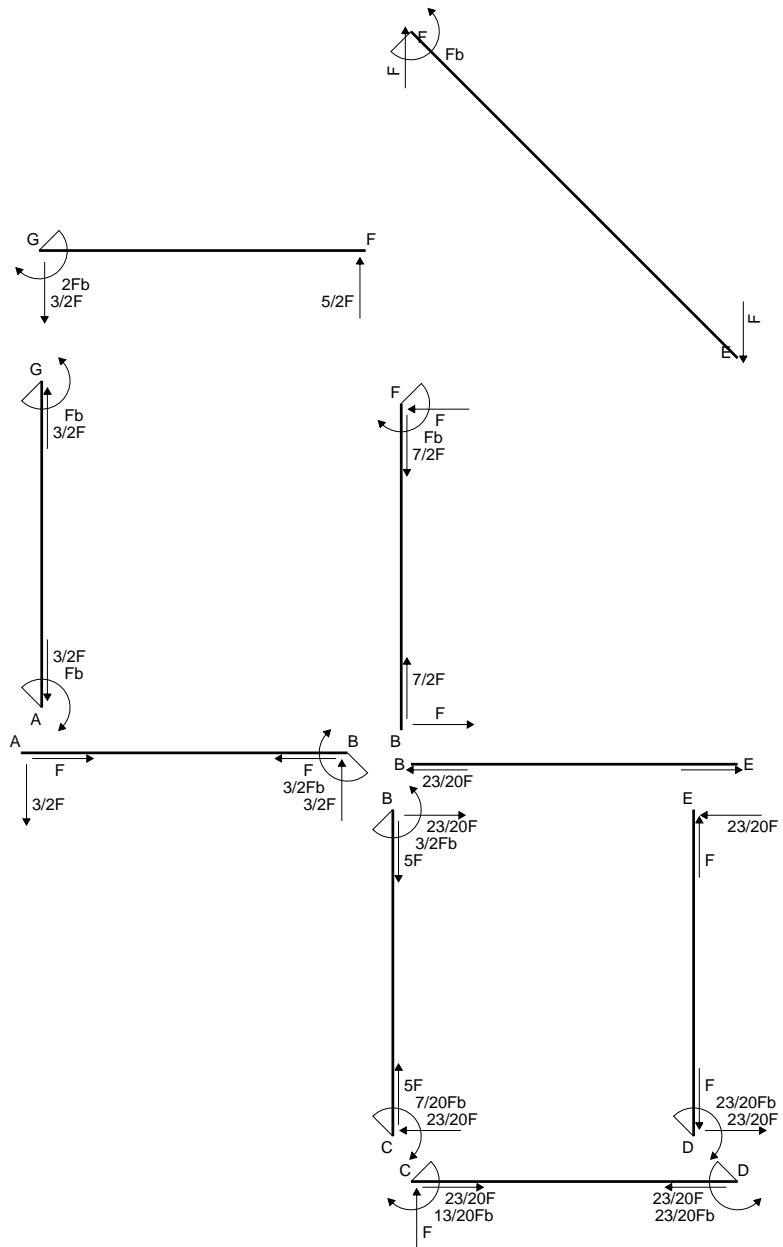

← ⊕ → F

↑ ⊕ ↓ F

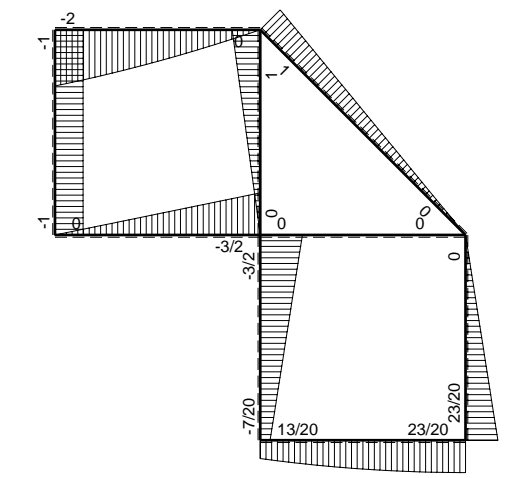

⊕ ⊖ Fb

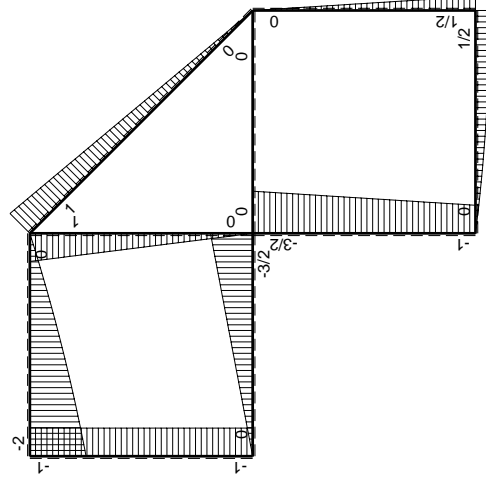
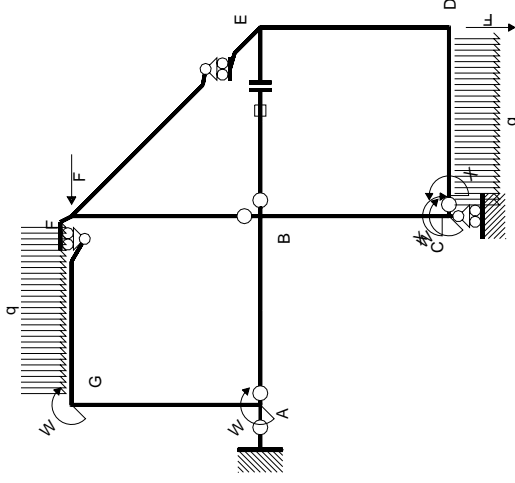

M_0 flessione da carichi assegnati

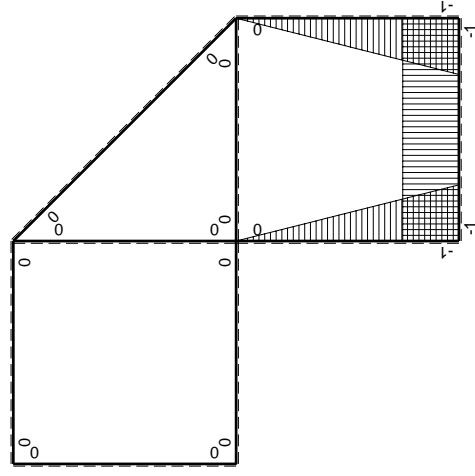

M_x flessione da iperstatica $X=1$

Quadro contribuiti PLV per iperstatica $X=W_{cd}$

\rightarrow	$M_x(x)$	$M_0(x)$	$M_x M_0$	$M_x M_x$	$\int M_x M_0 / EJ dx$	$\int M_x M_x / EJ dx$
AB b	0	-3/2Fx	0	0	0	0
BA b	0	3/2Fb-3/2Fx	0	0	0	0
BC b	-x/b	-3/2Fb+1/2Fx	3/2Fx-1/2Fx ² /b	x ² /b ²	7/12Fb ² /EJ	1/3Xb/EJ
CB b	1-x/b	Fb+1/2Fx	Fb-1/2Fx-1/2Fx ² /b	1-2x/b+x ² /b ²		
CD b	-1	Fx-1/2qx ²	-Fx+1/2Fx ² /b	1	-1/3Fb ² /EJ	Xb/EJ
DC b	1	-1/2Fb+1/2qx ²	-1/2Fb+1/2Fx ² /b	1		
DE b	-1+x/b	1/2Fb-1/2Fx	-1/2Fb+Fx-1/2Fx ² /b	1-2x/b+x ² /b ²	-1/6Fb ² /EJ	1/3Xb/EJ
ED b	x/b	-1/2Fx	-1/2Fx ² /b	x ² /b ²		
EF $\sqrt{2}b$	0	$\sqrt{2}/2Fx$	0	0	0	0
FG b	0	-5/2Fx+1/2qx ²	0	0	0	0
GF b	0	2Fb-3/2Fx-1/2qx ²	0	0	0	0
GA b	0	-Fb	0	0	0	0
AG b	0	Fb	0	0	0	0
FB b	0	Fb-Fx	0	0	0	0
BF b	0	-Fx	0	0	0	0
BE b	0	0	0	0	0	0
EB b	0	0	0	0	0	0
BE	elongazione asta $N_{1BE}^E - N_{BE}^E - N_{BE}^E$				Fb ² /EJ	
	totali				13/12Fb ² /EJ	5/3Xb/EJ
	iperstatica $X=W_{cd}$				-13/20Fb	

Sviluppi di calcolo iperstatica

$$L_{BC}^{xx} = \int_0^b (x^2/b^2) 1/EJ dx = [1/3 x^3/b^2]_0^b 1/EJ$$

$$= (1/3 b) 1/EJ = 1/3 b/EJ$$

$$L_{CB}^{xx} = \int_0^b (1 - 2x/b + x^2/b^2) 1/EJ dx = [x - x^2/b + 1/3 x^3/b^2]_0^b 1/EJ$$

$$= (b - b + 1/3 b) 1/EJ = 1/3 b/EJ$$

$$L_{CD}^{xx} = \int_0^b (1) 1/EJ dx = [x]_0^b 1/EJ$$

$$= (b) 1/EJ = b/EJ$$

$$L_{DC}^{xx} = \int_0^b (1) 1/EJ dx = [x]_0^b 1/EJ$$

$$= (b) 1/EJ = b/EJ$$

$$L_{DE}^{xx} = \int_0^b (1 - 2x/b + x^2/b^2) 1/EJ dx = [x - x^2/b + 1/3 x^3/b^2]_0^b 1/EJ$$

$$= (b - b + 1/3 b) 1/EJ = 1/3 b/EJ$$

$$L_{ED}^{xx} = \int_0^b (x^2/b^2) 1/EJ dx = [1/3 x^3/b^2]_0^b 1/EJ$$

$$= (1/3 b) 1/EJ = 1/3 b/EJ$$

$$L_{BC}^{xo} = \int_0^b (3/2 x/b - 1/2 x^2/b^2) Fb 1/EJ dx = [3/4 x^2/b - 1/6 x^3/b^2]_0^b Fb 1/EJ$$

$$= (3/4 b - 1/6 b) Fb 1/EJ = 7/12 Fb^2/EJ$$

$$L_{CB}^{xo} = \int_0^b (1 - 1/2 x/b - 1/2 x^2/b^2) Fb 1/EJ dx = [x - 1/4 x^2/b - 1/6 x^3/b^2]_0^b Fb 1/EJ$$

$$= (b - 1/4 b - 1/6 b) Fb 1/EJ = 7/12 Fb^2/EJ$$

$$L_{CD}^{xo} = \int_0^b (-x/b + 1/2 x^2/b^2) Fb 1/EJ dx = [-1/2 x^2/b + 1/6 x^3/b^2]_0^b Fb 1/EJ$$

$$= (-1/2 b + 1/6 b) Fb 1/EJ = -1/3 Fb^2/EJ$$

$$L_{DC}^{xo} = \int_0^b (-1/2 + 1/2 x^2/b^2) Fb 1/EJ dx = [-1/2 x + 1/6 x^3/b^2]_0^b Fb 1/EJ$$

$$= (-1/2 b + 1/6 b) Fb 1/EJ = -1/3 Fb^2/EJ$$

$$L_{DE}^{xo} = \int_0^b (-1/2 + x/b - 1/2 x^2/b^2) Fb 1/EJ dx = [-1/2 x + 1/2 x^2/b - 1/6 x^3/b^2]_0^b Fb 1/EJ$$

$$= (-1/2 b + 1/2 b - 1/6 b) Fb 1/EJ = -1/6 Fb^2/EJ$$

$$L_{ED}^{xo} = \int_0^b (-1/2 x^2/b^2) Fb 1/EJ dx = [-1/6 x^3/b^2]_0^b Fb 1/EJ$$

$$= (-1/6 b) Fb 1/EJ = -1/6 Fb^2/EJ$$

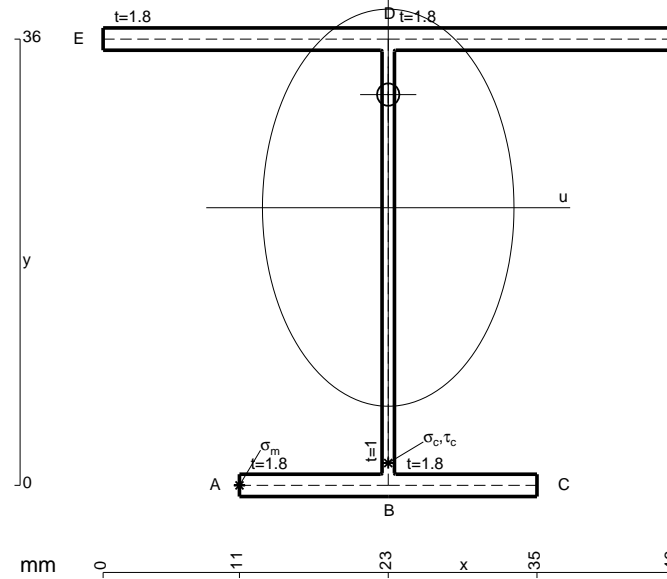

- A = 162. mm²
- J_u = 41576. mm⁴
- J_v = 16674. mm⁴
- J_i = 148.1 mm⁴
- y_o = 9.123 mm
- y_g = 22.4 mm
- T_y = -540. N
- M_x = -388800. Nmm
- x_m = 11. mm
- u_m = -12. mm
- v_m = -22.4 mm
- σ_m = -Mv/J_u = -209.5 N/mm²
- x_c = 23. mm
- v_c = -22.4 mm
- σ_c = -Mv/J_u = -209.5 N/mm²
- τ_c = TS_v/tJ_u = 12.57 N/mm²
- τ_g = TS_v/tJ_u = 12.57 N/mm²
- t_c = 360. mm
- σ_o = √σ²+3τ² = 210.6 N/mm²

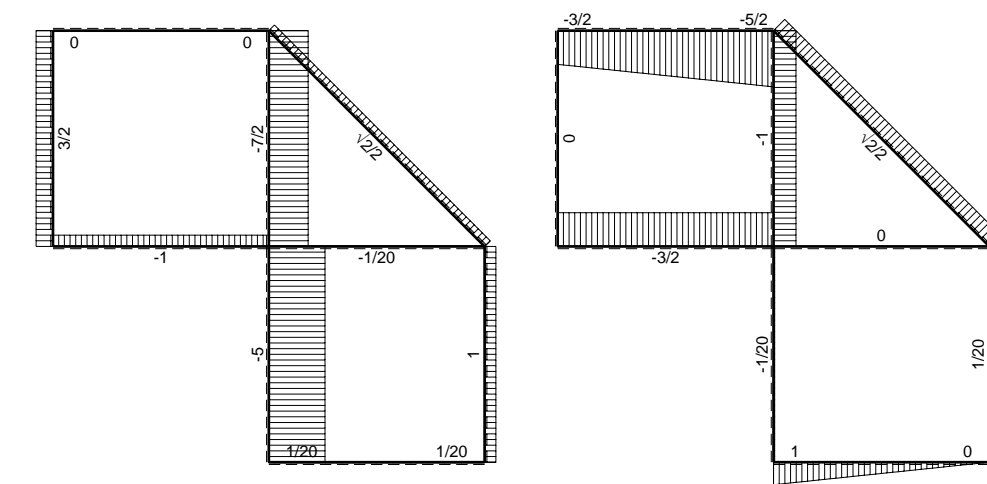
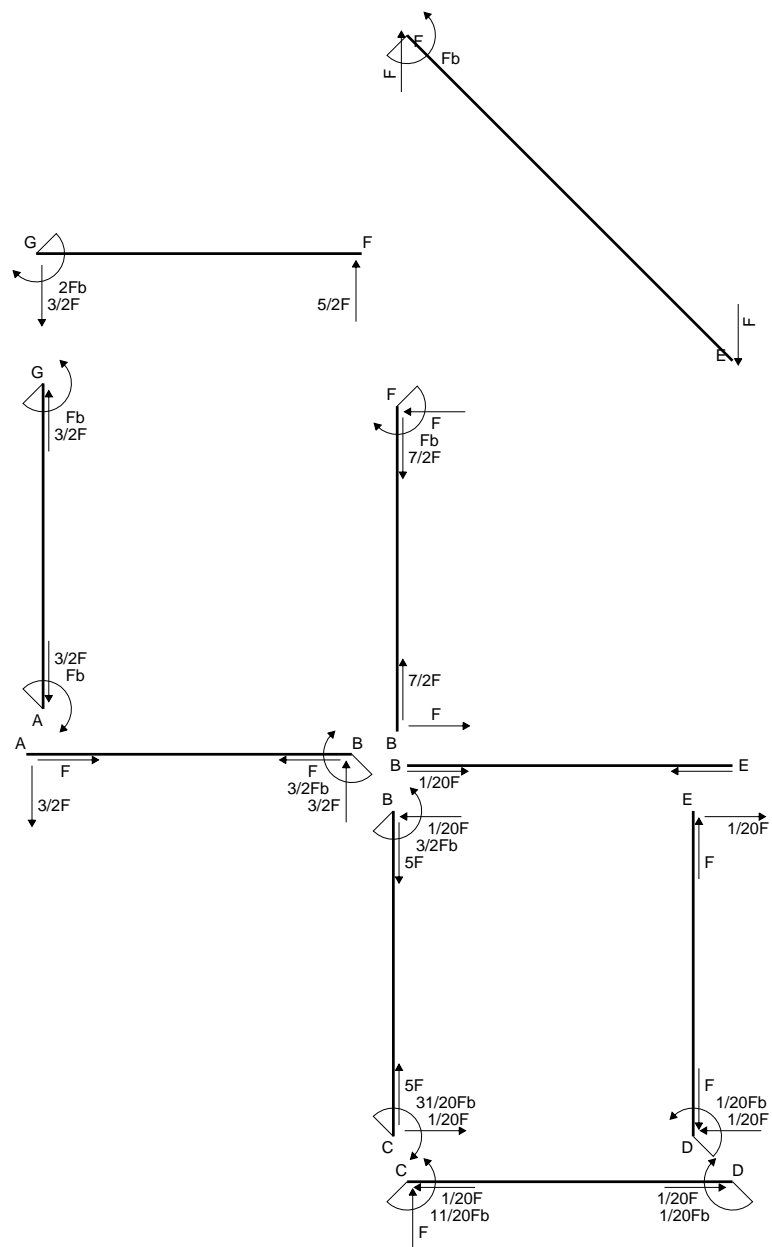

← ⊕ → F

↑ ⊕ ↓ F

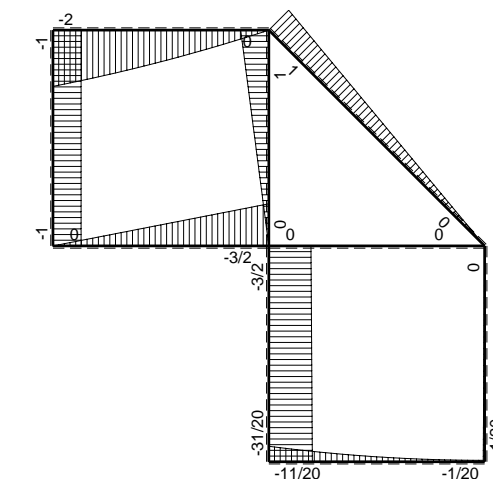

⊕ ⊖ F_b

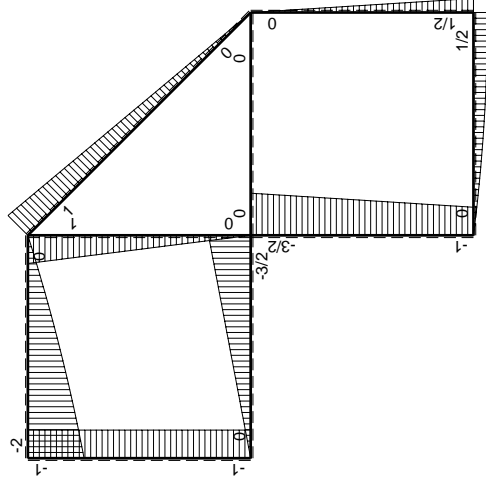
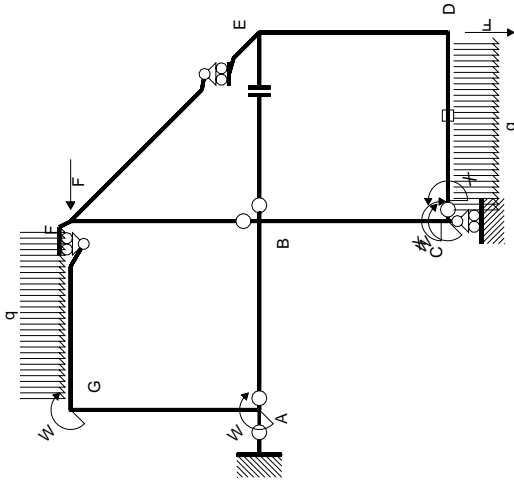

M_0 flessione da carichi assegnati

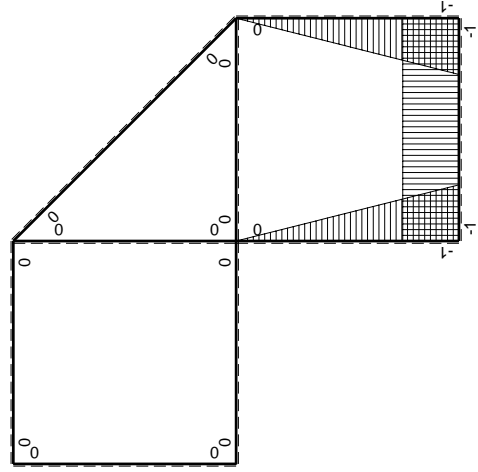

M_x flessione da iperstatica $X=1$

Quadro contribuiti PLV per iperstatica $X=W_{cd}$

\rightarrow	$M_x(x)$	$M_0(x)$	$M_x M_0$	$M_x M_x$	$\int M_x M_0 / EJ dx$	$\int M_x M_x / EJ dx$
AB b	0	-3/2Fx	0	0	0	0
BA b	0	3/2Fb-3/2Fx	0	0	0	0
BC b	-x/b	-3/2Fb+1/2Fx	3/2Fx-1/2Fx ² /b	x ² /b ²	7/12Fb ² /EJ	1/3Xb/EJ
CB b	1-x/b	Fb+1/2Fx	Fb-1/2Fx-1/2Fx ² /b	1-2x/b+x ² /b ²		
CD b	-1	Fx-1/2qx ²	-Fx+1/2Fx ² /b	1	-1/3Fb ² /EJ	Xb/EJ
DC b	1	-1/2Fb+1/2qx ²	-1/2Fb+1/2Fx ² /b	1		
DE b	-1+x/b	1/2Fb-1/2Fx	-1/2Fb+Fx-1/2Fx ² /b	1-2x/b+x ² /b ²	-1/6Fb ² /EJ	1/3Xb/EJ
ED b	x/b	-1/2Fx	-1/2Fx ² /b	x ² /b ²		
EF $\sqrt{2}b$	0	$\sqrt{2}/2Fx$	0	0	0	0
FG b	0	-5/2Fx+1/2qx ²	0	0	0	0
GF b	0	2Fb-3/2Fx-1/2qx ²	0	0	0	0
GA b	0	-Fb	0	0	0	0
AG b	0	Fb	0	0	0	0
FB b	0	Fb-Fx	0	0	0	0
BF b	0	-Fx	0	0	0	0
BE b	0	0	0	0	0	0
EB b	0	0	0	0	0	0
CD	elongazione asta $N_{1,cd} \epsilon_{cd} L_{cd}$				-Fb ² /EJ	
	totali				-11/12Fb ² /EJ	5/3Xb/EJ
	iperstatica $X=W_{cd}$				11/20Fb	

Sviluppi di calcolo iperstatica

$$L_{BC}^{xx} = \int_0^b (x^2/b^2) 1/EJ dx = [1/3 x^3/b^2]_0^b 1/EJ$$

$$= (1/3 b) 1/EJ = 1/3 b/EJ$$

$$L_{CB}^{xx} = \int_0^b (1 - 2x/b + x^2/b^2) 1/EJ dx = [x - x^2/b + 1/3 x^3/b^2]_0^b 1/EJ$$

$$= (b - b + 1/3 b) 1/EJ = 1/3 b/EJ$$

$$L_{CD}^{xx} = \int_0^b (1) 1/EJ dx = [x]_0^b 1/EJ$$

$$= (b) 1/EJ = b/EJ$$

$$L_{DC}^{xx} = \int_0^b (1) 1/EJ dx = [x]_0^b 1/EJ$$

$$= (b) 1/EJ = b/EJ$$

$$L_{DE}^{xx} = \int_0^b (1 - 2x/b + x^2/b^2) 1/EJ dx = [x - x^2/b + 1/3 x^3/b^2]_0^b 1/EJ$$

$$= (b - b + 1/3 b) 1/EJ = 1/3 b/EJ$$

$$L_{ED}^{xx} = \int_0^b (x^2/b^2) 1/EJ dx = [1/3 x^3/b^2]_0^b 1/EJ$$

$$= (1/3 b) 1/EJ = 1/3 b/EJ$$

$$L_{BC}^{x_0} = \int_0^b (3/2 x/b - 1/2 x^2/b^2) Fb 1/EJ dx = [3/4 x^2/b - 1/6 x^3/b^2]_0^b Fb 1/EJ$$

$$= (3/4 b - 1/6 b) Fb 1/EJ = 7/12 Fb^2/EJ$$

$$L_{CB}^{x_0} = \int_0^b (1 - 1/2 x/b - 1/2 x^2/b^2) Fb 1/EJ dx = [x - 1/4 x^2/b - 1/6 x^3/b^2]_0^b Fb 1/EJ$$

$$= (b - 1/4 b - 1/6 b) Fb 1/EJ = 7/12 Fb^2/EJ$$

$$L_{CD}^{x_0} = \int_0^b (-x/b + 1/2 x^2/b^2) Fb 1/EJ dx + 1 (-1) 1 Fb^2/EJ$$

$$= [-1/2 x^2/b + 1/6 x^3/b^2]_0^b Fb 1/EJ + 1 (-1) 1 Fb^2/EJ$$

$$= (-1/2 b + 1/6 b) Fb 1/EJ + 1 (-1) 1 Fb^2/EJ = -4/3 Fb^2/EJ$$

$$L_{DC}^{x_0} = \int_0^b (-1/2 + 1/2 x^2/b^2) Fb 1/EJ dx + 1 (-1) 1 Fb^2/EJ$$

$$= [-1/2 x + 1/6 x^3/b^2]_0^b Fb 1/EJ + 1 (-1) 1 Fb^2/EJ$$

$$= (-1/2 b + 1/6 b) Fb 1/EJ + 1 (-1) 1 Fb^2/EJ = -4/3 Fb^2/EJ$$

$$L_{DE}^{x_0} = \int_0^b (-1/2 + x/b - 1/2 x^2/b^2) Fb 1/EJ dx = [-1/2 x + 1/2 x^2/b - 1/6 x^3/b^2]_0^b Fb 1/EJ$$

$$= (-1/2 b + 1/2 b - 1/6 b) Fb 1/EJ = -1/6 Fb^2/EJ$$

$$L_{ED}^{x_0} = \int_0^b (-1/2 x^2/b^2) Fb 1/EJ dx = [-1/6 x^3/b^2]_0^b Fb 1/EJ$$

$$= (-1/6 b) Fb 1/EJ = -1/6 Fb^2/EJ$$

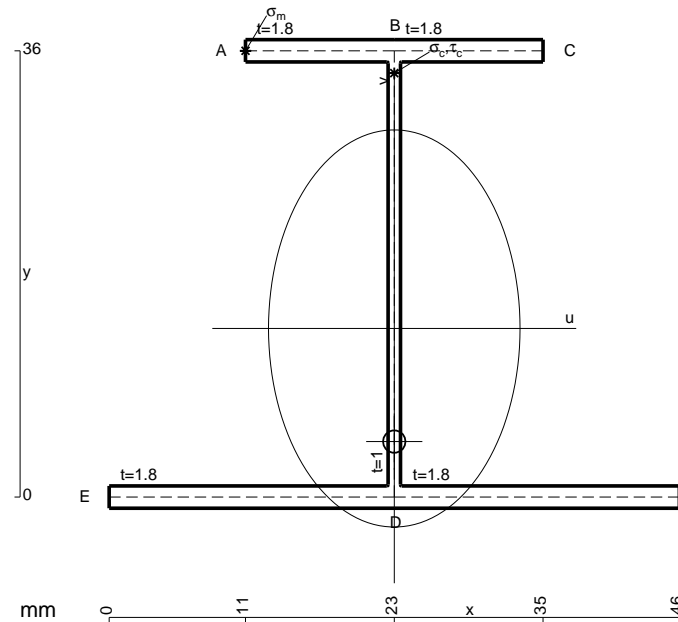

- A = 162. mm²
- J_u = 41576. mm⁴
- J_v = 16674. mm⁴
- J_t = 148.1 mm⁴
- y_o = -9.123 mm
- y_g = 13.6 mm
- T_y = -525. N
- M_x = -399000. Nmm
- x_m = 11. mm
- y_m = 36. mm
- u_m = -12. mm
- v_m = 22.4 mm
- σ_m = -Mv/J_u = 215. N/mm²
- x_c = 23. mm
- y_c = 36. mm
- v_c = 22.4 mm
- σ_c = -Mv/J_u = 215. N/mm²
- τ_c = TS/tJ_u = 12.22 N/mm²
- τ_g = TS/tJ_u = 12.22 N/mm²
- t_c = 350. mm
- σ_o = √σ²+3τ² = 216. N/mm²

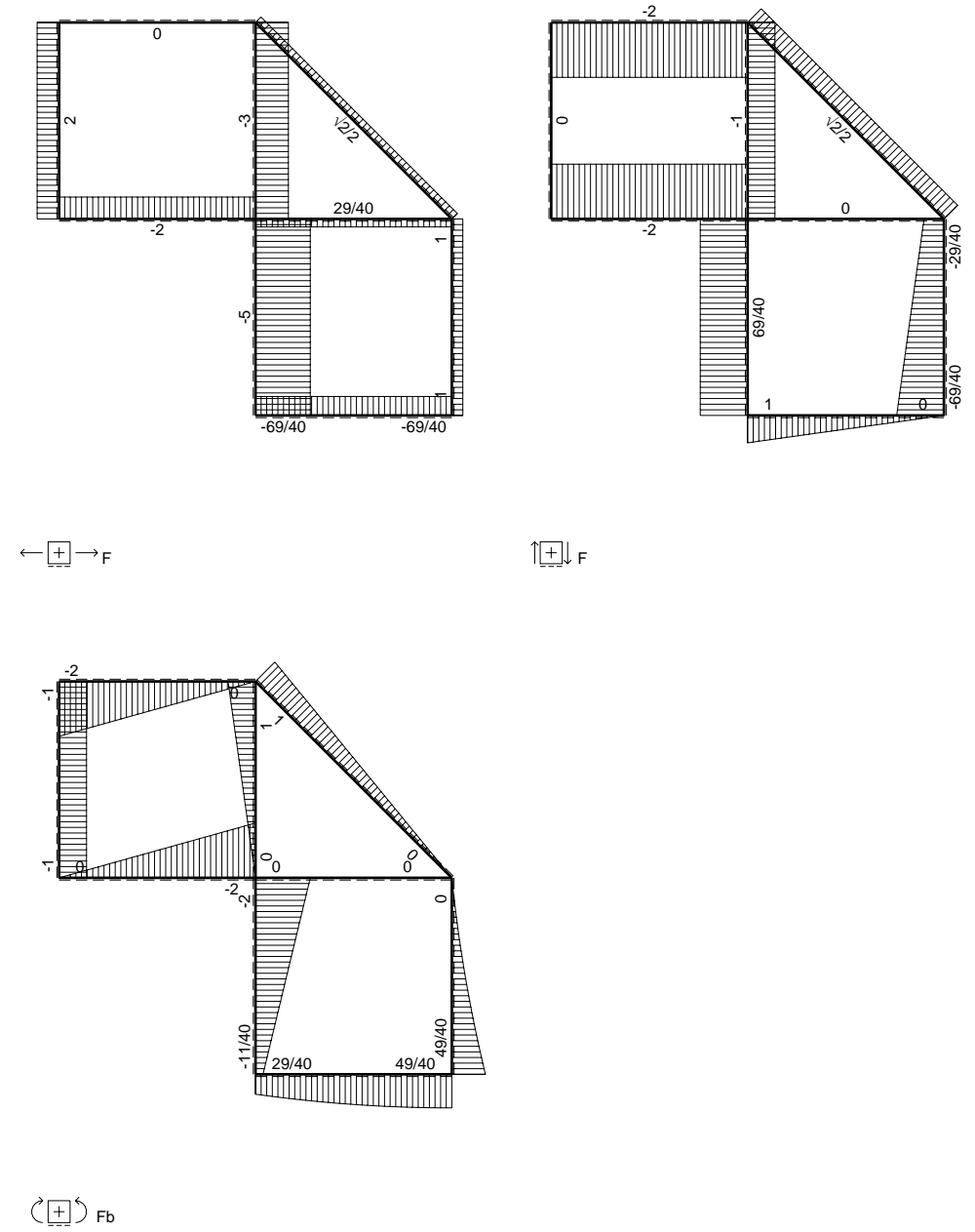
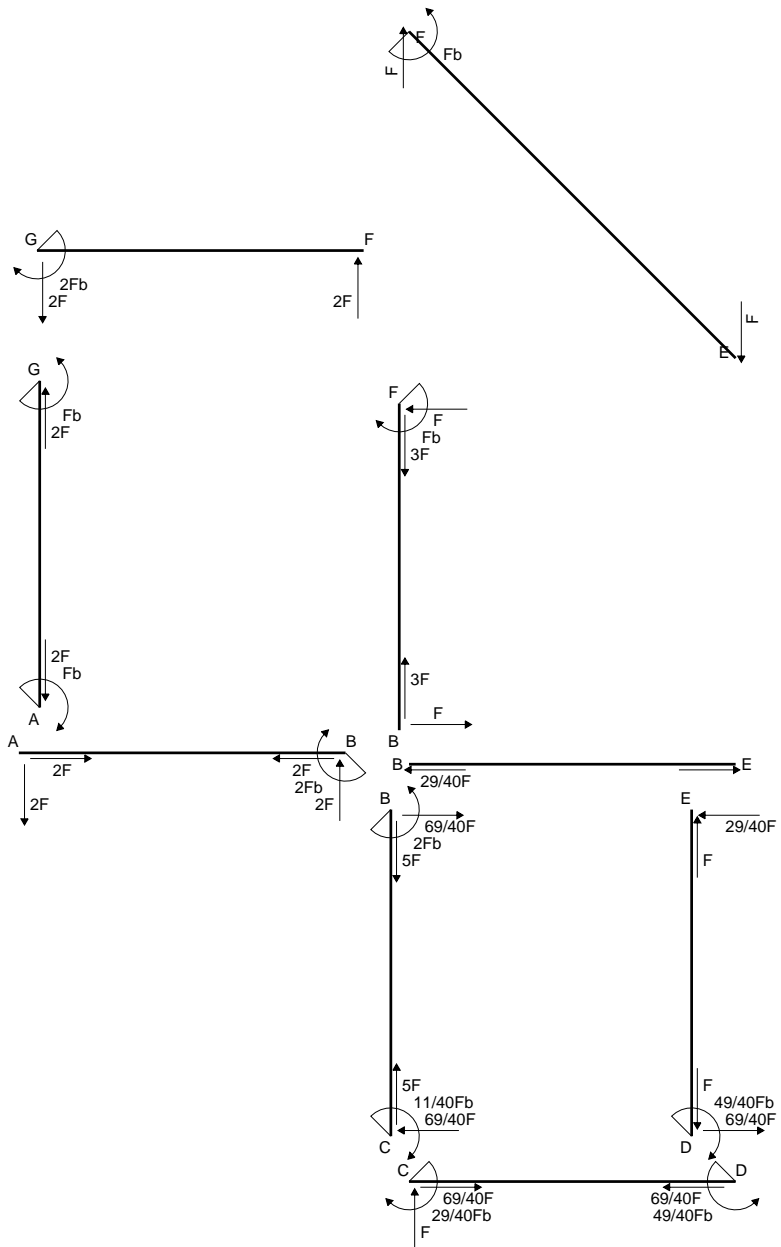

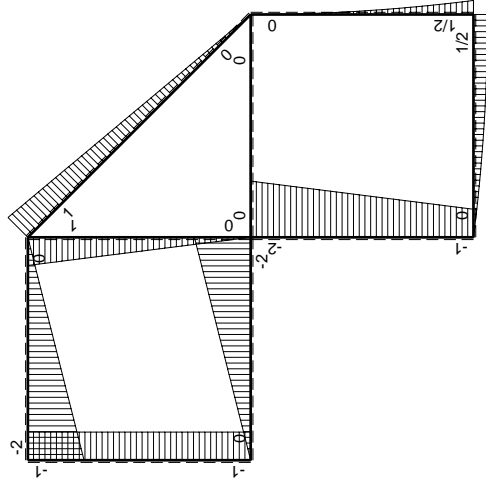
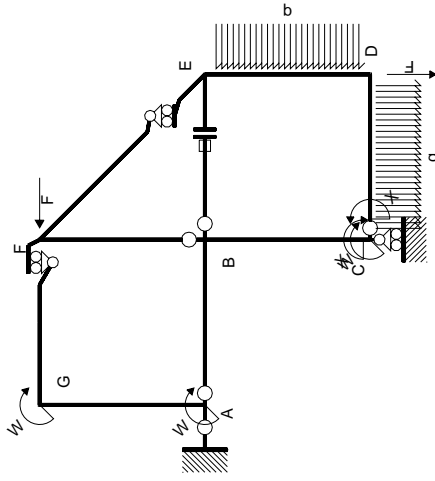

M_0 flessione da carichi assegnati

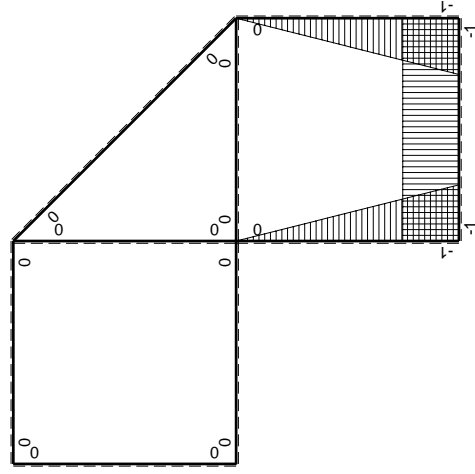

M_x flessione da iperstatica $X=1$

Quadro contributi PLV per iperstatica $X=W_{CD}$

→	$M_x(x)$	$M_o(x)$	$M_x M_o$	$M_x M_x$	$\int M_x M_o / EJ dx$	$\int X M_x M_x / EJ dx$
AB b	0	-2Fx	0	0	0	0
BA b	0	2Fb-2Fx	0	0		
BC b	-x/b	-2Fb+Fx	$2Fx-Fx^2/b$	x^2/b^2	$2/3Fb^2/EJ$	$1/3Xb/EJ$
CB b	1-x/b	Fb+Fx	$Fb-Fx^2/b$	$1-2x/b+x^2/b^2$		
CD b	-1	$Fx-1/2qx^2$	$-Fx+1/2Fx^2/b$	1	$-1/3Fb^2/EJ$	Xb/EJ
DC b	1	$-1/2Fb+1/2qx^2$	$-1/2Fb+1/2Fx^2/b$	1		
DE b	-1+x/b	$1/2Fb-Fx+1/2qx^2$	$-1/2Fb+3/2Fx-3/2Fx^2/b+1/2qx^3/b$	$1-2x/b+x^2/b^2$	$-1/8Fb^2/EJ$	$1/3Xb/EJ$
ED b	x/b	$-1/2qx^2$	$-1/2qx^3/b$	x^2/b^2		
EF $\sqrt{2}b$	0	$\sqrt{2}/2Fx$	0	0	0	0
FG b	0	-2Fx	0	0	0	0
GF b	0	2Fb-2Fx	0	0		
GA b	0	-Fb	0	0	0	0
AG b	0	Fb	0	0		
FB b	0	Fb-Fx	0	0	0	0
BF b	0	-Fx	0	0		
BE b	0	0	0	0	0	0
EB b	0	0	0	0		
BE	elongazione asta $N_{1BE} \epsilon_{BE} L_{BE}$				Fb^2/EJ	
	totali				$29/24Fb^2/EJ$	$5/3Xb/EJ$
	iperstatica $X=W_{CD}$				$-29/40Fb$	

Sviluppi di calcolo iperstatica

$$L_{BC}^{xx} = \int_0^b (x^2/b^2) 1/EJ dx = [1/3 x^3/b^2]_0^b 1/EJ$$

$$= (1/3 b) 1/EJ = 1/3 b/EJ$$

$$L_{CB}^{xx} = \int_0^b (1 - 2x/b + x^2/b^2) 1/EJ dx = [x - x^2/b + 1/3 x^3/b^2]_0^b 1/EJ$$

$$= (b - b + 1/3 b) 1/EJ = 1/3 b/EJ$$

$$L_{CD}^{xx} = \int_0^b (1) 1/EJ dx = [x]_0^b 1/EJ$$

$$= (b) 1/EJ = b/EJ$$

$$L_{DC}^{xx} = \int_0^b (1) 1/EJ dx = [x]_0^b 1/EJ$$

$$= (b) 1/EJ = b/EJ$$

$$L_{DE}^{xx} = \int_0^b (1 - 2x/b + x^2/b^2) 1/EJ dx = [x - x^2/b + 1/3 x^3/b^2]_0^b 1/EJ$$

$$= (b - b + 1/3 b) 1/EJ = 1/3 b/EJ$$

$$L_{ED}^{xx} = \int_0^b (x^2/b^2) 1/EJ dx = [1/3 x^3/b^2]_0^b 1/EJ$$

$$= (1/3 b) 1/EJ = 1/3 b/EJ$$

$$L_{BC}^{xo} = \int_0^b (2x/b - x^2/b^2) Fb 1/EJ dx = [x^2/b - 1/3 x^3/b^2]_0^b Fb 1/EJ$$

$$= (b - 1/3 b) Fb 1/EJ = 2/3 Fb^2/EJ$$

$$L_{CB}^{xo} = \int_0^b (1 - x^2/b^2) Fb 1/EJ dx = [x - 1/3 x^3/b^2]_0^b Fb 1/EJ$$

$$= (b - 1/3 b) Fb 1/EJ = 2/3 Fb^2/EJ$$

$$L_{CD}^{xo} = \int_0^b (-x/b + 1/2 x^2/b^2) Fb 1/EJ dx = [-1/2 x^2/b + 1/6 x^3/b^2]_0^b Fb 1/EJ$$

$$= (-1/2 b + 1/6 b) Fb 1/EJ = -1/3 Fb^2/EJ$$

$$L_{DC}^{xo} = \int_0^b (-1/2 + 1/2 x^2/b^2) Fb 1/EJ dx = [-1/2 x + 1/6 x^3/b^2]_0^b Fb 1/EJ$$

$$= (-1/2 b + 1/6 b) Fb 1/EJ = -1/3 Fb^2/EJ$$

$$L_{DE}^{xo} = \int_0^b (-1/2 + 3/2 x/b - 3/2 x^2/b^2 + 1/2 x^3/b^3) Fb 1/EJ dx$$

$$= [-1/2 x + 3/4 x^2/b - 1/2 x^3/b^2 + 1/8 x^4/b^3]_0^b Fb 1/EJ$$

$$= (-1/2 b + 3/4 b - 1/2 b + 1/8 b) Fb 1/EJ = -1/8 Fb^2/EJ$$

$$L_{ED}^{xo} = \int_0^b (-1/2 x^3/b^3) Fb 1/EJ dx = [-1/8 x^4/b^3]_0^b Fb 1/EJ$$

$$= (-1/8 b) Fb 1/EJ = -1/8 Fb^2/EJ$$

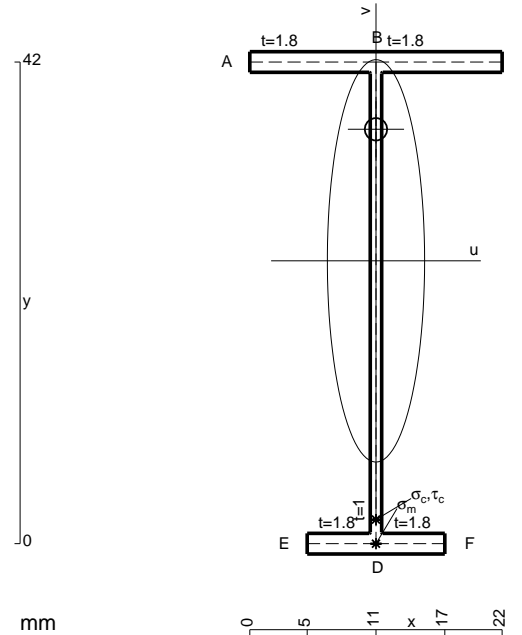

- A = 103.2 mm²
- J_u = 31779. mm⁴
- J_v = 1856. mm⁴
- J_i = 80.1 mm⁴
- y_o = 11.47 mm
- y_g = 24.66 mm
- N = -400. N
- T_y = -400. N
- M_x = -288000. Nmm
- x_m = 11. mm
- v_m = -24.66 mm
- σ_m = N/A-Mv/J_u = -227.4 N/mm²
- y_c = 3. mm
- u_c = -11. mm
- v_c = -21.66 mm
- σ_c = N/A-Mv/J_u = -227.4 N/mm²
- τ_c = TS'/tJ_u = 6.705 N/mm²
- τ_g = TS'/tJ_u = 6.705 N/mm²
- t_c = 200. mm
- σ_o = √σ²+3τ² = 227.7 N/mm²

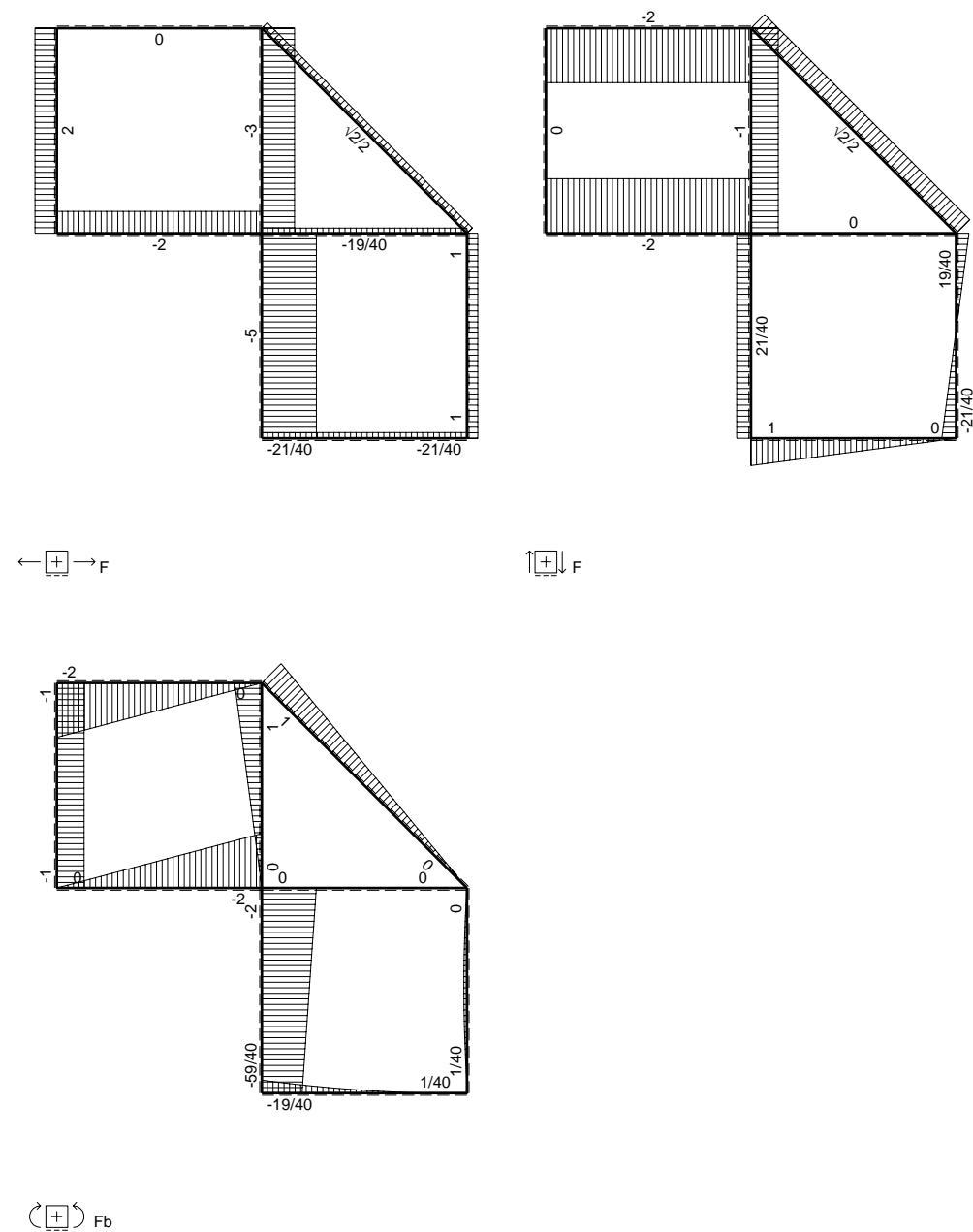
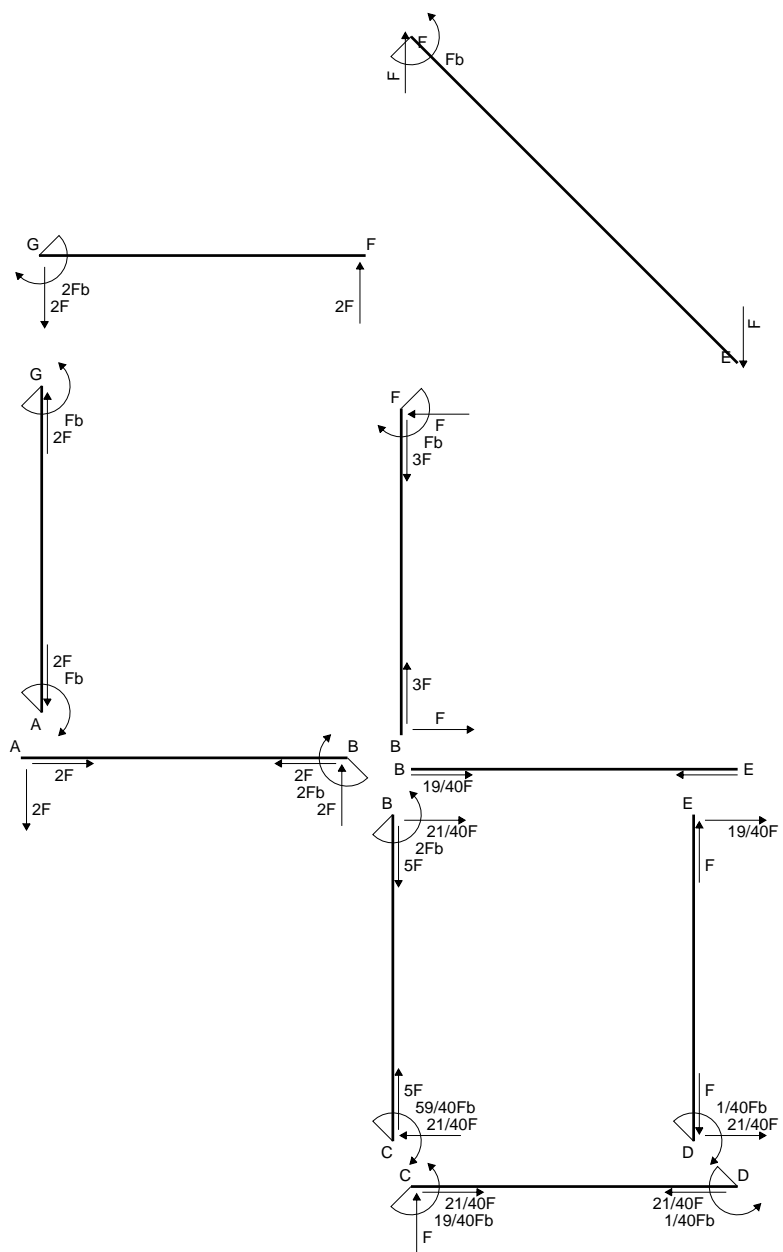

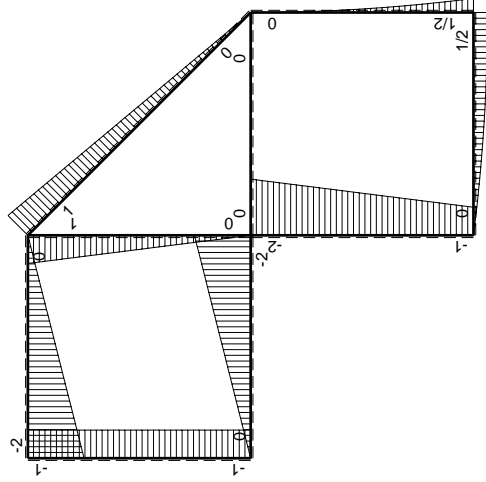
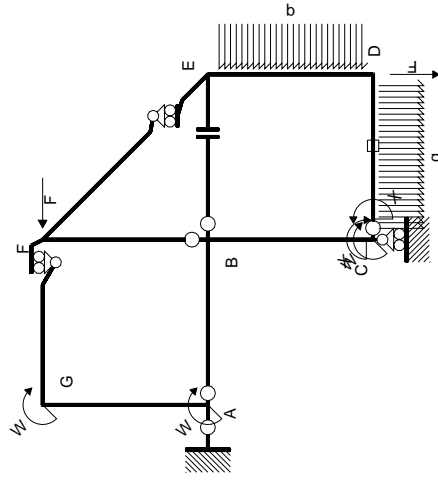

M_0 flessione da carichi assegnati

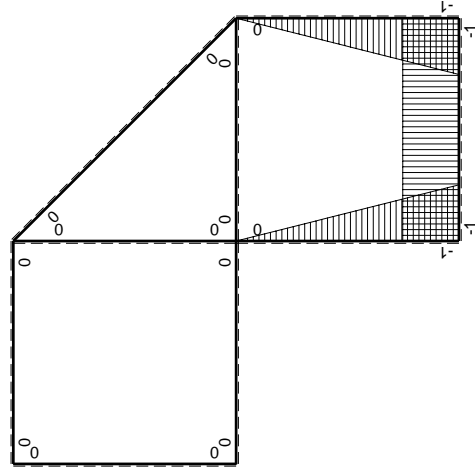

M_x flessione da iperstatica $X=1$

Quadro contributi PLV per iperstatica $X=W_{CD}$

→	$M_x(x)$	$M_o(x)$	$M_x M_o$	$M_x M_x$	$\int M_x M_o / EJ dx$	$\int X M_x M_x / EJ dx$
AB b	0	-2Fx	0	0	0	0
BA b	0	2Fb-2Fx	0	0	0	0
BC b	-x/b	-2Fb+Fx	$2Fx-Fx^2/b$	x^2/b^2	$2/3Fb^2/EJ$	$1/3Xb/EJ$
CB b	1-x/b	Fb+Fx	$Fb-Fx^2/b$	$1-2x/b+x^2/b^2$	$2/3Fb^2/EJ$	$1/3Xb/EJ$
CD b	-1	$Fx-1/2qx^2$	$-Fx+1/2Fx^2/b$	1	$-1/3Fb^2/EJ$	Xb/EJ
DC b	1	$-1/2Fb+1/2qx^2$	$-1/2Fb+1/2Fx^2/b$	1	$-1/3Fb^2/EJ$	Xb/EJ
DE b	-1+x/b	$1/2Fb-Fx+1/2qx^2$	$-1/2Fb+3/2Fx-3/2Fx^2/b+1/2qx^3/b$	$1-2x/b+x^2/b^2$	$-1/8Fb^2/EJ$	$1/3Xb/EJ$
ED b	x/b	$-1/2qx^2$	$-1/2qx^3/b$	x^2/b^2	$-1/8Fb^2/EJ$	$1/3Xb/EJ$
EF $\sqrt{2}b$	0	$\sqrt{2}/2Fx$	0	0	0	0
FG b	0	-2Fx	0	0	0	0
GF b	0	2Fb-2Fx	0	0	0	0
GA b	0	-Fb	0	0	0	0
AG b	0	Fb	0	0	0	0
FB b	0	Fb-Fx	0	0	0	0
BF b	0	-Fx	0	0	0	0
BE b	0	0	0	0	0	0
EB b	0	0	0	0	0	0
CD	elongazione asta $N_{1CD} \epsilon_{CD} L_{CD}$				$-Fb^2/EJ$	
	totali				$-19/24Fb^2/EJ$	$5/3Xb/EJ$
	iperstatica $X=W_{CD}$				$19/40Fb$	

Sviluppi di calcolo iperstatica

$$L_{BC}^{xx} = \int_0^b (x^2/b^2) 1/EJ dx = [1/3 x^3/b^2]_0^b 1/EJ$$

$$= (1/3 b) 1/EJ = 1/3 b/EJ$$

$$L_{CB}^{xx} = \int_0^b (1 - 2x/b + x^2/b^2) 1/EJ dx = [x - x^2/b + 1/3 x^3/b^2]_0^b 1/EJ$$

$$= (b - b + 1/3 b) 1/EJ = 1/3 b/EJ$$

$$L_{CD}^{xx} = \int_0^b (1) 1/EJ dx = [x]_0^b 1/EJ$$

$$= (b) 1/EJ = b/EJ$$

$$L_{DC}^{xx} = \int_0^b (1) 1/EJ dx = [x]_0^b 1/EJ$$

$$= (b) 1/EJ = b/EJ$$

$$L_{DE}^{xx} = \int_0^b (1 - 2x/b + x^2/b^2) 1/EJ dx = [x - x^2/b + 1/3 x^3/b^2]_0^b 1/EJ$$

$$= (b - b + 1/3 b) 1/EJ = 1/3 b/EJ$$

$$L_{ED}^{xx} = \int_0^b (x^2/b^2) 1/EJ dx = [1/3 x^3/b^2]_0^b 1/EJ$$

$$= (1/3 b) 1/EJ = 1/3 b/EJ$$

$$L_{BC}^{xo} = \int_0^b (2x/b - x^2/b^2) Fb 1/EJ dx = [x^2/b - 1/3 x^3/b^2]_0^b Fb 1/EJ$$

$$= (b - 1/3 b) Fb 1/EJ = 2/3 Fb^2/EJ$$

$$L_{CB}^{xo} = \int_0^b (1 - x^2/b^2) Fb 1/EJ dx = [x - 1/3 x^3/b^2]_0^b Fb 1/EJ$$

$$= (b - 1/3 b) Fb 1/EJ = 2/3 Fb^2/EJ$$

$$L_{CD}^{xo} = \int_0^b (-x/b + 1/2 x^2/b^2) Fb 1/EJ dx + 1 (-1) 1 Fb^2/EJ$$

$$= [-1/2 x^2/b + 1/6 x^3/b^2]_0^b Fb 1/EJ + 1 (-1) 1 Fb^2/EJ$$

$$= (-1/2 b + 1/6 b) Fb 1/EJ + 1 (-1) 1 Fb^2/EJ = -4/3 Fb^2/EJ$$

$$L_{DC}^{xo} = \int_0^b (-1/2 + 1/2 x^2/b^2) Fb 1/EJ dx + 1 (-1) 1 Fb^2/EJ$$

$$= [-1/2 x + 1/6 x^3/b^2]_0^b Fb 1/EJ + 1 (-1) 1 Fb^2/EJ$$

$$= (-1/2 b + 1/6 b) Fb 1/EJ + 1 (-1) 1 Fb^2/EJ = -4/3 Fb^2/EJ$$

$$L_{DE}^{xo} = \int_0^b (-1/2 + 3/2 x/b - 3/2 x^2/b^2 + 1/2 x^3/b^3) Fb 1/EJ dx$$

$$= [-1/2 x + 3/4 x^2/b - 1/2 x^3/b^2 + 1/8 x^4/b^3]_0^b Fb 1/EJ$$

$$= (-1/2 b + 3/4 b - 1/2 b + 1/8 b) Fb 1/EJ = -1/8 Fb^2/EJ$$

$$L_{ED}^{xo} = \int_0^b (-1/2 x^3/b^3) Fb 1/EJ dx = [-1/8 x^4/b^3]_0^b Fb 1/EJ$$

$$= (-1/8 b) Fb 1/EJ = -1/8 Fb^2/EJ$$

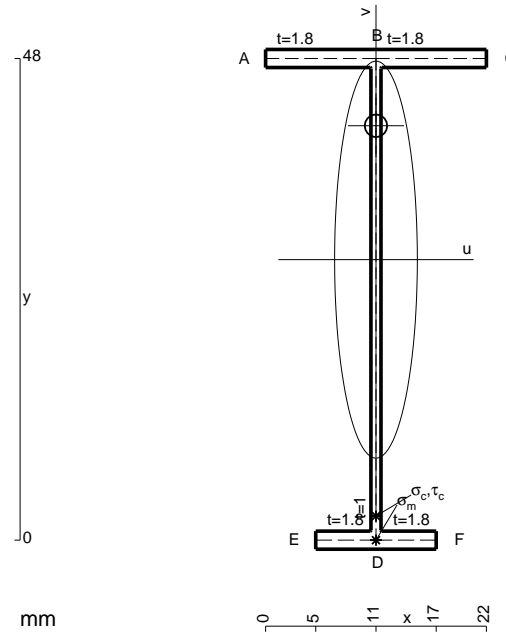

$$A = 109.2 \text{ mm}^2$$

$$J_u = 42758. \text{ mm}^4$$

$$J_v = 1856. \text{ mm}^4$$

$$J_t = 82.1 \text{ mm}^4$$

$$y_o = 13.34 \text{ mm}$$

$$y_g = 27.96 \text{ mm}$$

$$N = -420. \text{ N}$$

$$T_y = -420. \text{ N}$$

$$M_x = -357000. \text{ Nmm}$$

$$x_m = 11. \text{ mm}$$

$$v_m = -27.96 \text{ mm}$$

$$\sigma_m = N/A - Mv/J_u = -237.3 \text{ N/mm}^2$$

$$y_c = 3. \text{ mm}$$

$$u_c = -11. \text{ mm}$$

$$v_c = -24.96 \text{ mm}$$

$$\sigma_c = N/A - Mv/J_u = -237.3 \text{ N/mm}^2$$

$$\tau_c = TS/tJ_u = 5.931 \text{ N/mm}^2$$

$$\tau_g = TS/tJ_u = 5.931 \text{ N/mm}^2$$

$$t_c = 210. \text{ mm}$$

$$\sigma_o = \sqrt{\sigma^2 + 3\tau^2} = 237.5 \text{ N/mm}^2$$

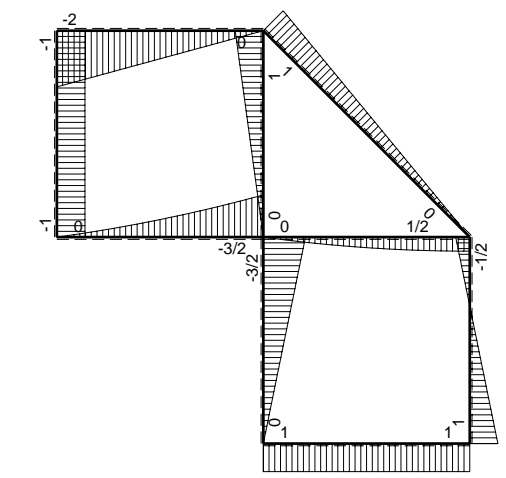
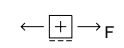
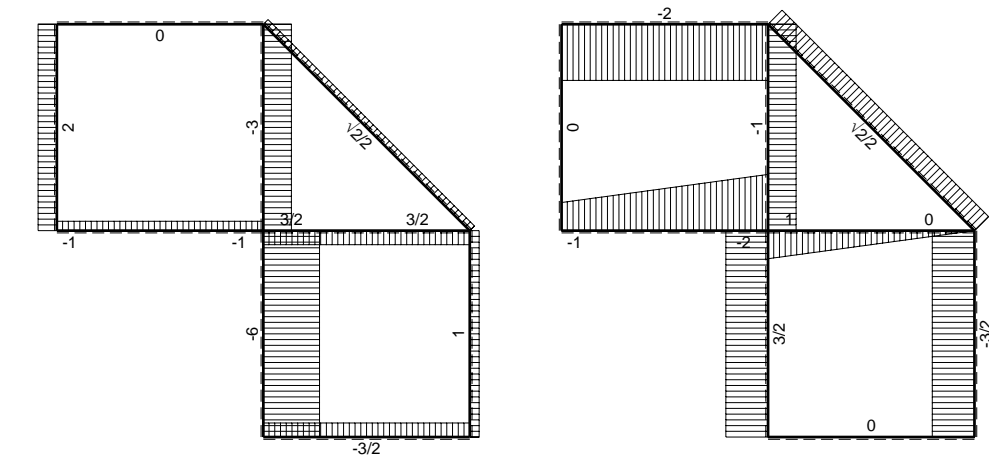
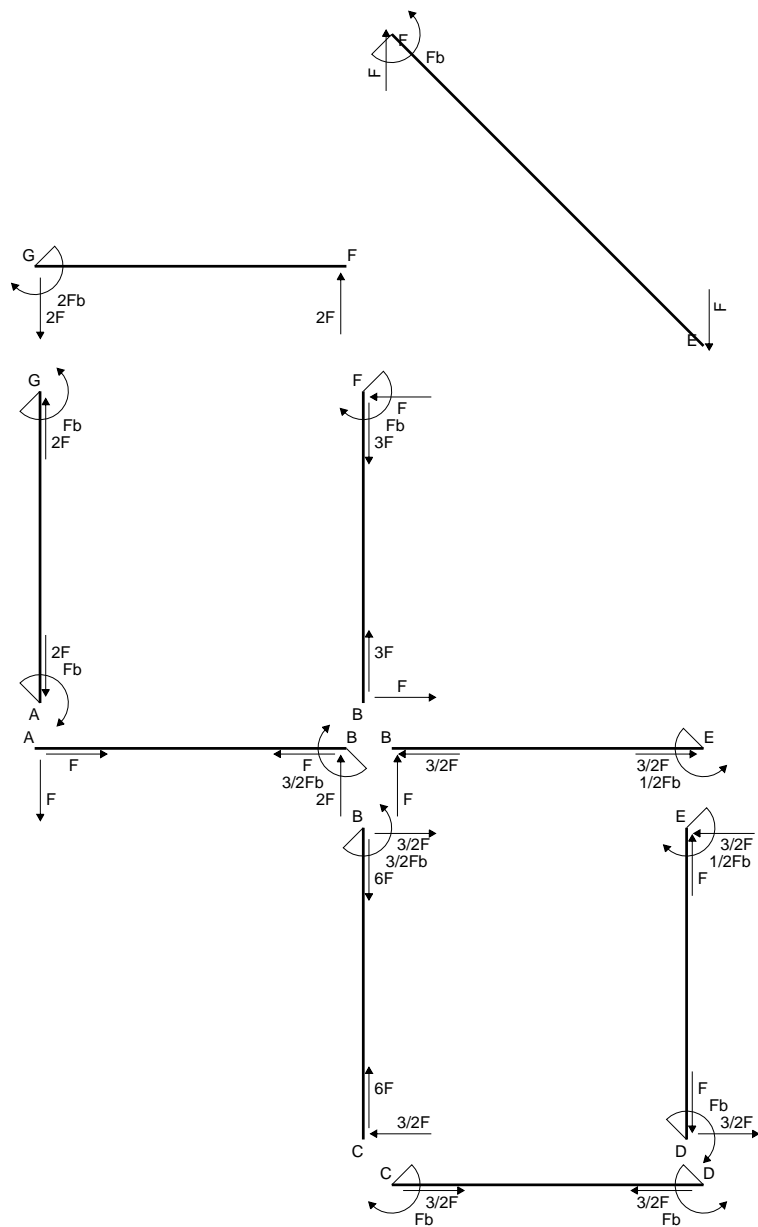

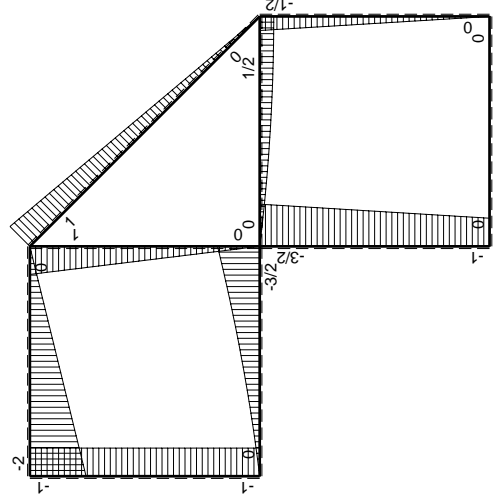
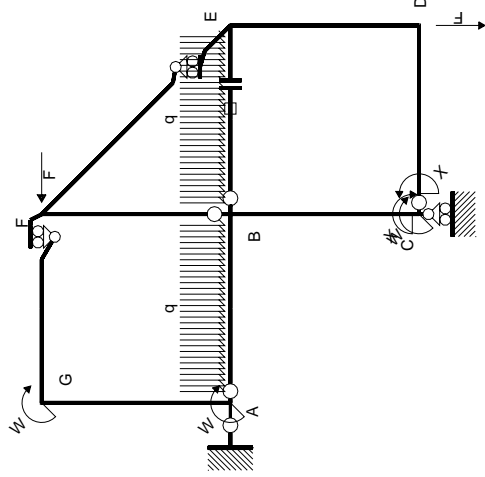

Schema di calcolo iperstatico

M_0 flessione da carichi assegnati

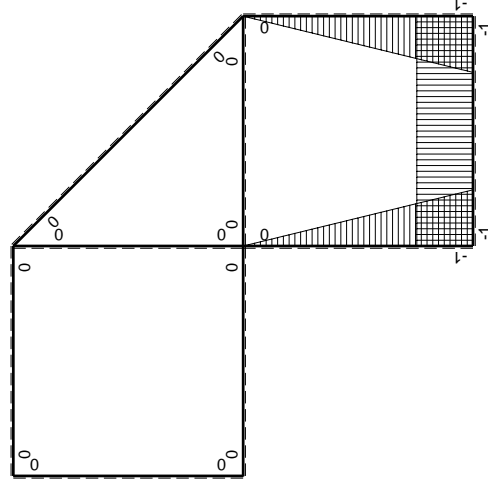

M_x flessione da iperstatica X=1

Quadro contribuiti PLV per iperstatica X=W_{cd}

→	$M_x(x)$	$M_0(x)$	$M_x M_0$	$M_x M_x$	$\int M_x M_0 / E J dx$	$\int X M_x M_x / E J dx$
AB b	0	$-Fx - 1/2qx^2$	0	0	0	0
BA b	0	$3/2Fb - 2Fx + 1/2qx^2$	0	0	0	0
BC b	$-x/b$	$-3/2Fb + 1/2Fx$	$3/2Fx - 1/2Fx^2/b$	x^2/b^2	$7/12Fb^2/EJ$	$1/3Xb/EJ$
CB b	$1-x/b$	$Fb + 1/2Fx$	$Fb - 1/2Fx - 1/2Fx^2/b$	$1 - 2x/b + x^2/b^2$	0	0
CD b	-1	0	0	1	0	Xb/EJ
DC b	1	0	0	1	0	0
DE b	$-1+x/b$	$-1/2Fx$	$1/2Fx - 1/2Fx^2/b$	$1 - 2x/b + x^2/b^2$	$1/12Fb^2/EJ$	$1/3Xb/EJ$
ED b	x/b	$1/2Fb - 1/2Fx$	$1/2Fx - 1/2Fx^2/b$	x^2/b^2	0	0
EF $\sqrt{2}b$	0	$\sqrt{2}/2Fx$	0	0	0	0
FG b	0	$-2Fx$	0	0	0	0
GF b	0	$2Fb - 2Fx$	0	0	0	0
GA b	0	$-Fb$	0	0	0	0
AG b	0	Fb	0	0	0	0
FB b	0	$Fb - Fx$	0	0	0	0
BF b	0	$-Fx$	0	0	0	0
BE b	0	$Fx - 1/2qx^2$	0	0	0	0
EB b	0	$-1/2Fb + 1/2qx^2$	0	0	0	0
BE	elongazione asta $N_{1, BE}^E - L_{BE}^{L-BE}$				Fb^2/EJ	
	totali				$5/3Fb^2/EJ$	$5/3Xb/EJ$
	iperstatica X=W _{cd}				$-Fb$	

Sviluppi di calcolo iperstatica

$$L_{BC}^{xx} = \int_0^b (x^2/b^2) 1/EJ dx = [1/3 x^3/b^2]_0^b 1/EJ$$

$$= (1/3 b) 1/EJ = 1/3 b/EJ$$

$$L_{CB}^{xx} = \int_0^b (1 - 2x/b + x^2/b^2) 1/EJ dx = [x - x^2/b + 1/3 x^3/b^2]_0^b 1/EJ$$

$$= (b - b + 1/3 b) 1/EJ = 1/3 b/EJ$$

$$L_{CD}^{xx} = \int_0^b (1) 1/EJ dx = [x]_0^b 1/EJ$$

$$= (b) 1/EJ = b/EJ$$

$$L_{DC}^{xx} = \int_0^b (1) 1/EJ dx = [x]_0^b 1/EJ$$

$$= (b) 1/EJ = b/EJ$$

$$L_{DE}^{xx} = \int_0^b (1 - 2x/b + x^2/b^2) 1/EJ dx = [x - x^2/b + 1/3 x^3/b^2]_0^b 1/EJ$$

$$= (b - b + 1/3 b) 1/EJ = 1/3 b/EJ$$

$$L_{ED}^{xx} = \int_0^b (x^2/b^2) 1/EJ dx = [1/3 x^3/b^2]_0^b 1/EJ$$

$$= (1/3 b) 1/EJ = 1/3 b/EJ$$

$$L_{BC}^{x_0} = \int_0^b (3/2 x/b - 1/2 x^2/b^2) Fb 1/EJ dx = [3/4 x^2/b - 1/6 x^3/b^2]_0^b Fb 1/EJ$$

$$= (3/4 b - 1/6 b) Fb 1/EJ = 7/12 Fb^2/EJ$$

$$L_{CB}^{x_0} = \int_0^b (1 - 1/2 x/b - 1/2 x^2/b^2) Fb 1/EJ dx = [x - 1/4 x^2/b - 1/6 x^3/b^2]_0^b Fb 1/EJ$$

$$= (b - 1/4 b - 1/6 b) Fb 1/EJ = 7/12 Fb^2/EJ$$

$$L_{DE}^{x_0} = \int_0^b (1/2 x/b - 1/2 x^2/b^2) Fb 1/EJ dx = [1/4 x^2/b - 1/6 x^3/b^2]_0^b Fb 1/EJ$$

$$= (1/4 b - 1/6 b) Fb 1/EJ = 1/12 Fb^2/EJ$$

$$L_{ED}^{x_0} = \int_0^b (1/2 x/b - 1/2 x^2/b^2) Fb 1/EJ dx = [1/4 x^2/b - 1/6 x^3/b^2]_0^b Fb 1/EJ$$

$$= (1/4 b - 1/6 b) Fb 1/EJ = 1/12 Fb^2/EJ$$

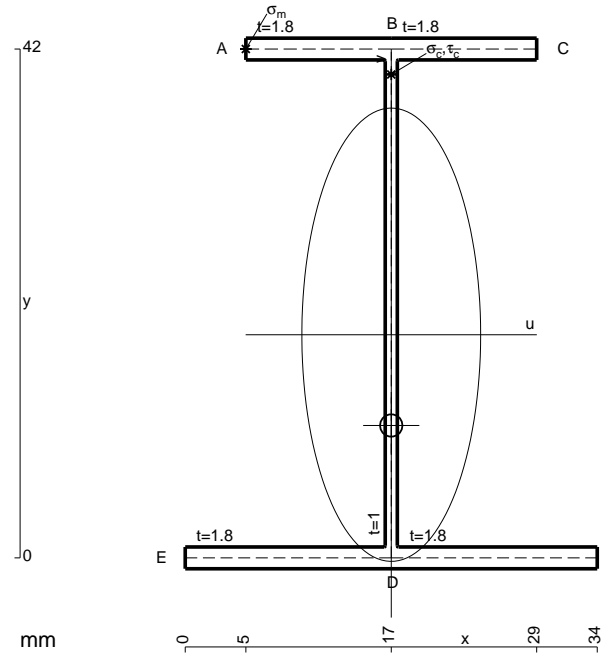

- A = 146.4 mm²
- J_u = 51238. mm⁴
- J_v = 7969. mm⁴
- J_i = 126.8 mm⁴
- y_o = -7.49 mm
- y_g = 18.42 mm
- T_y = -1080. N
- M_x = -432000. Nmm
- x_m = 5. mm
- y_m = 42. mm
- u_m = -12. mm
- v_m = 23.58 mm
- σ_m = -M_v/J_u = 198.8 N/mm²
- x_c = 17. mm
- y_c = 42. mm
- v_c = 23.58 mm
- σ_c = -M_v/J_u = 198.8 N/mm²
- τ_c = T_S/t_{J_u} = 21.47 N/mm²
- τ_g = T_S/t_{J_u} = 21.47 N/mm²
- t_c = 540. mm
- σ_o = √(σ²+3τ²) = 202.3 N/mm²

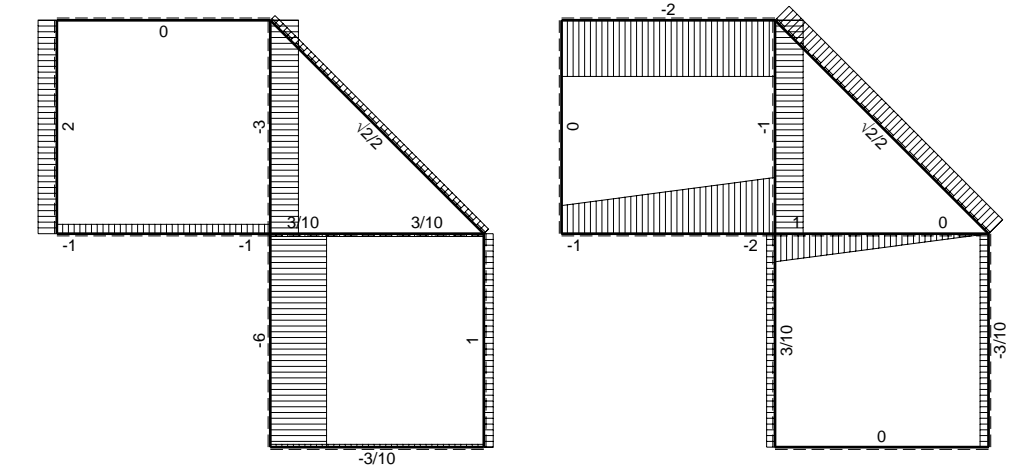
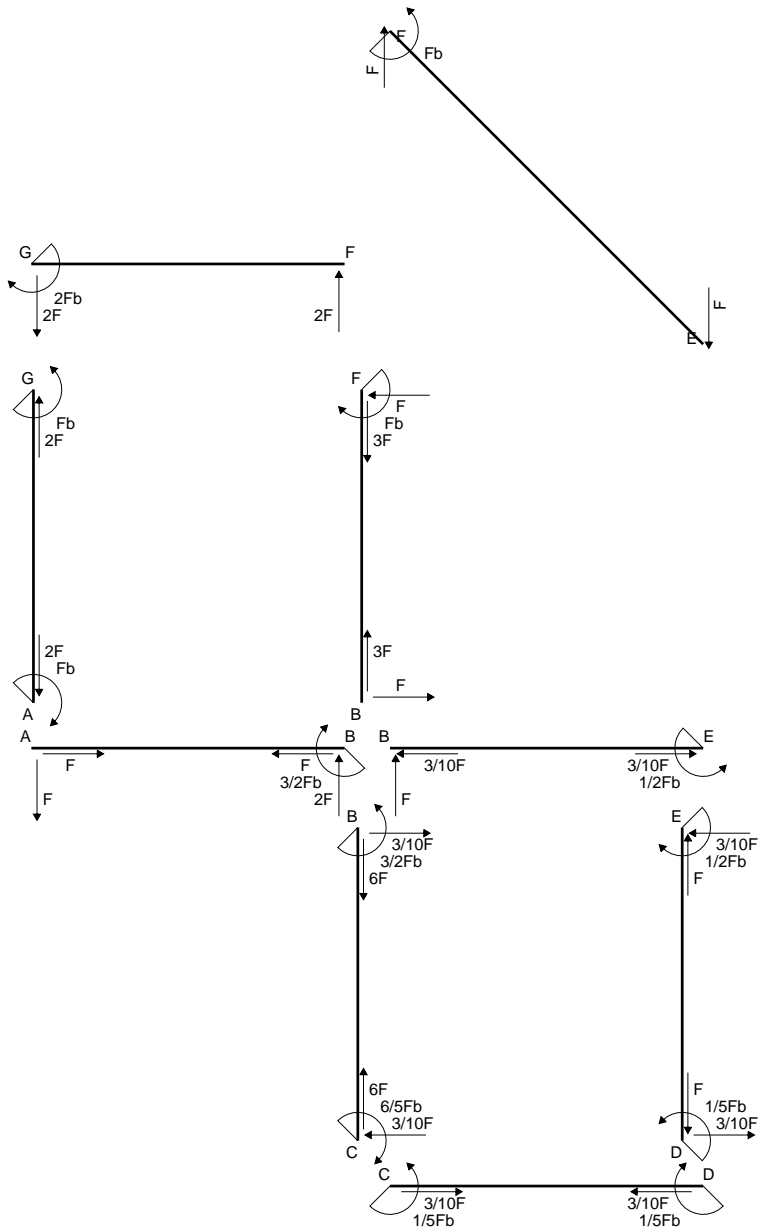

← (+) → F

↑ (+) ↓ F

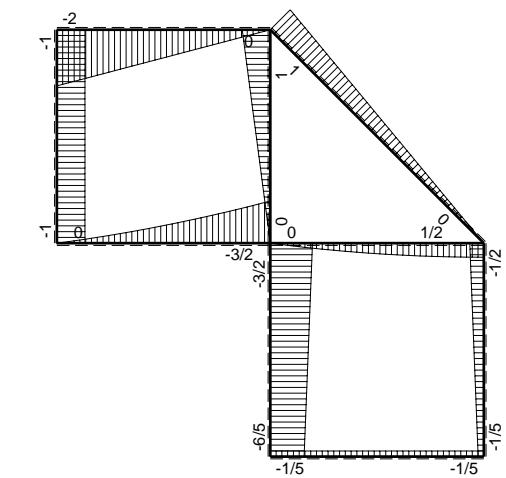

⊕ (+) ⊖ (-) F_b

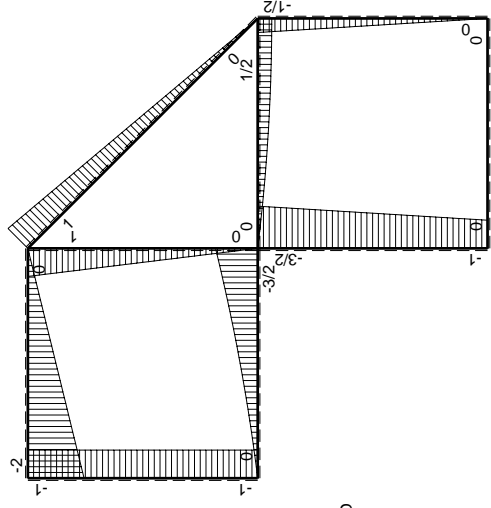
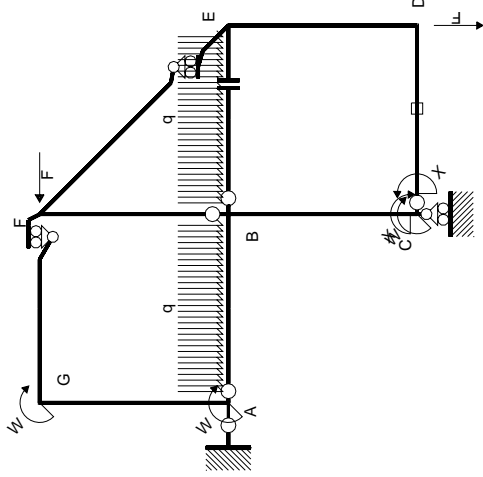

Schema di calcolo iperstatico

M_0 flessione da carichi assegnati

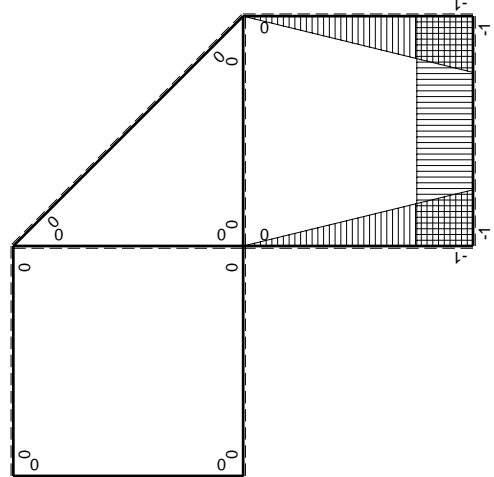

M_x flessione da iperstatica X=1

Quadro contribuiti PLV per iperstatica X=W_{cd}

→	$M_x(x)$	$M_0(x)$	$M_x M_0$	$M_x M_x$	$\int M_x M_0 / E J dx$	$\int X M_x M_x / E J dx$
AB b	0	$-Fx - 1/2qx^2$	0	0	0	0
BA b	0	$3/2Fb - 2Fx + 1/2qx^2$	0	0	0	0
BC b	$-x/b$	$-3/2Fb + 1/2Fx$	$3/2Fx - 1/2Fx^2/b$	x^2/b^2	$7/12Fb^2/EJ$	$1/3Xb/EJ$
CB b	$1-x/b$	$Fb + 1/2Fx$	$Fb - 1/2Fx - 1/2Fx^2/b$	$1 - 2x/b + x^2/b^2$	0	0
CD b	-1	0	0	1	0	Xb/EJ
DC b	1	0	0	1	0	0
DE b	$-1+x/b$	$-1/2Fx$	$1/2Fx - 1/2Fx^2/b$	$1 - 2x/b + x^2/b^2$	$1/12Fb^2/EJ$	$1/3Xb/EJ$
ED b	x/b	$1/2Fb - 1/2Fx$	$1/2Fx - 1/2Fx^2/b$	x^2/b^2	0	0
EF $\sqrt{2}b$	0	$\sqrt{2}/2Fx$	0	0	0	0
FG b	0	$-2Fx$	0	0	0	0
GF b	0	$2Fb - 2Fx$	0	0	0	0
GA b	0	$-Fb$	0	0	0	0
AG b	0	Fb	0	0	0	0
FB b	0	$Fb - Fx$	0	0	0	0
BF b	0	$-Fx$	0	0	0	0
BE b	0	$Fx - 1/2qx^2$	0	0	0	0
EB b	0	$-1/2Fb + 1/2qx^2$	0	0	0	0
CD	elongazione asta $N_{1,cd} \epsilon_{cd} L_{cd}$				$-Fb^2/EJ$	
	totali				$-1/3Fb^2/EJ$	$5/3Xb/EJ$
	iperstatica X=W _{cd}				$1/5Fb$	

Sviluppi di calcolo iperstatica

$$L_{BC}^{xx} = \int_0^b (x^2/b^2) 1/EJ dx = [1/3 x^3/b^2]_0^b 1/EJ$$

$$= (1/3 b) 1/EJ = 1/3 b/EJ$$

$$L_{CB}^{xx} = \int_0^b (1 - 2x/b + x^2/b^2) 1/EJ dx = [x - x^2/b + 1/3 x^3/b^2]_0^b 1/EJ$$

$$= (b - b + 1/3 b) 1/EJ = 1/3 b/EJ$$

$$L_{CD}^{xx} = \int_0^b (1) 1/EJ dx = [x]_0^b 1/EJ$$

$$= (b) 1/EJ = b/EJ$$

$$L_{DC}^{xx} = \int_0^b (1) 1/EJ dx = [x]_0^b 1/EJ$$

$$= (b) 1/EJ = b/EJ$$

$$L_{DE}^{xx} = \int_0^b (1 - 2x/b + x^2/b^2) 1/EJ dx = [x - x^2/b + 1/3 x^3/b^2]_0^b 1/EJ$$

$$= (b - b + 1/3 b) 1/EJ = 1/3 b/EJ$$

$$L_{ED}^{xx} = \int_0^b (x^2/b^2) 1/EJ dx = [1/3 x^3/b^2]_0^b 1/EJ$$

$$= (1/3 b) 1/EJ = 1/3 b/EJ$$

$$L_{BC}^{x_0} = \int_0^b (3/2 x/b - 1/2 x^2/b^2) Fb 1/EJ dx = [3/4 x^2/b - 1/6 x^3/b^2]_0^b Fb 1/EJ$$

$$= (3/4 b - 1/6 b) Fb 1/EJ = 7/12 Fb^2/EJ$$

$$L_{CB}^{x_0} = \int_0^b (1 - 1/2 x/b - 1/2 x^2/b^2) Fb 1/EJ dx = [x - 1/4 x^2/b - 1/6 x^3/b^2]_0^b Fb 1/EJ$$

$$= (b - 1/4 b - 1/6 b) Fb 1/EJ = 7/12 Fb^2/EJ$$

$$L_{DE}^{x_0} = \int_0^b (1/2 x/b - 1/2 x^2/b^2) Fb 1/EJ dx = [1/4 x^2/b - 1/6 x^3/b^2]_0^b Fb 1/EJ$$

$$= (1/4 b - 1/6 b) Fb 1/EJ = 1/12 Fb^2/EJ$$

$$L_{ED}^{x_0} = \int_0^b (1/2 x/b - 1/2 x^2/b^2) Fb 1/EJ dx = [1/4 x^2/b - 1/6 x^3/b^2]_0^b Fb 1/EJ$$

$$= (1/4 b - 1/6 b) Fb 1/EJ = 1/12 Fb^2/EJ$$

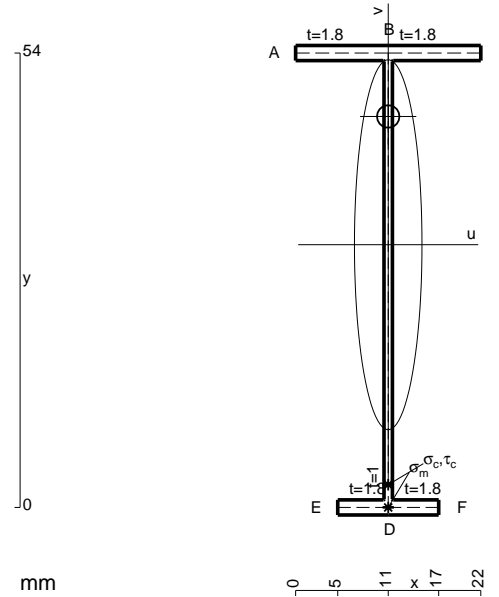

- A = 115.2 mm²
- J_u = 55687. mm⁴
- J_v = 1856. mm⁴
- J_i = 84.1 mm⁴
- y_o = 15.24 mm
- y_g = 31.22 mm
- T_y = -660. N
- M_x = -369600. Nmm
- x_m = 11. mm
- v_m = -31.22 mm
- σ_m = -Mv/J_u = -207.2 N/mm²
- y_c = 3. mm
- u_c = -11. mm
- v_c = -28.22 mm
- σ_c = -Mv/J_u = -207.2 N/mm²
- τ_c = TS_v/tJ_u = 7.992 N/mm²
- τ_g = TS_v/tJ_u = 7.992 N/mm²
- t_c = 330. mm
- σ_o = √σ²+3τ² = 207.7 N/mm²

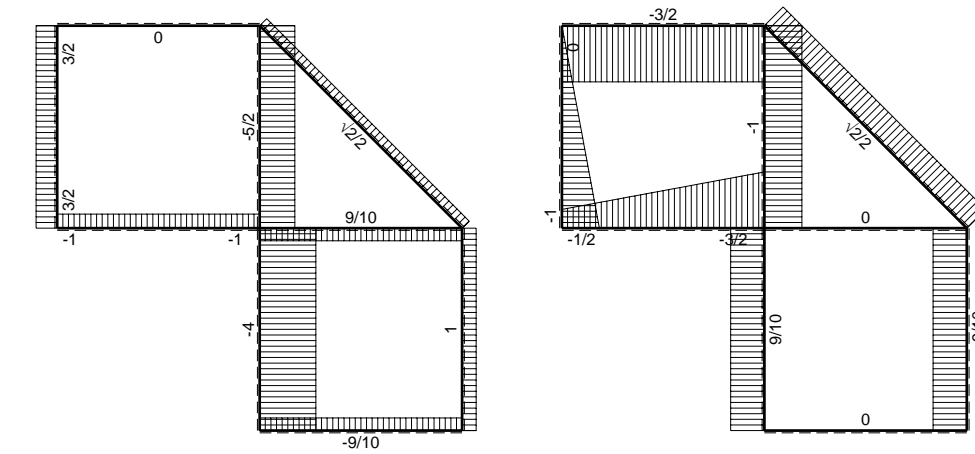
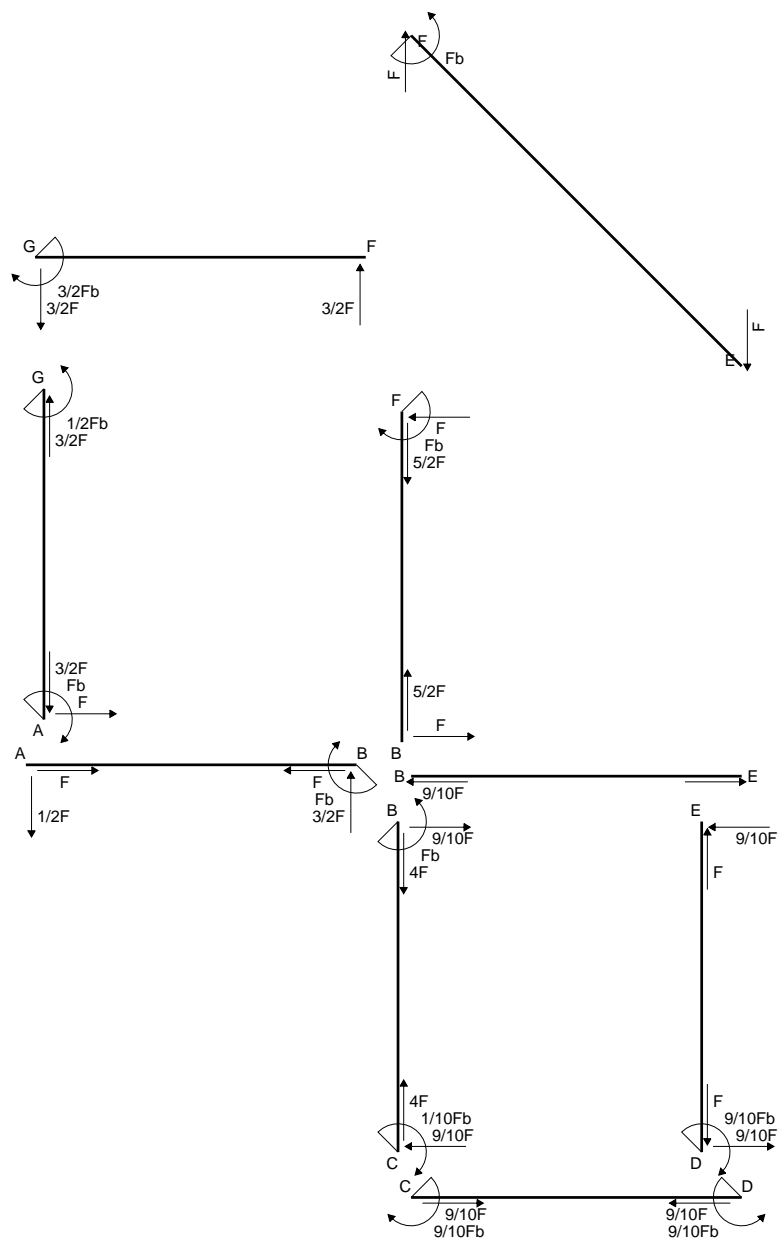

← ⊕ → F

↑ ⊕ ↓ F

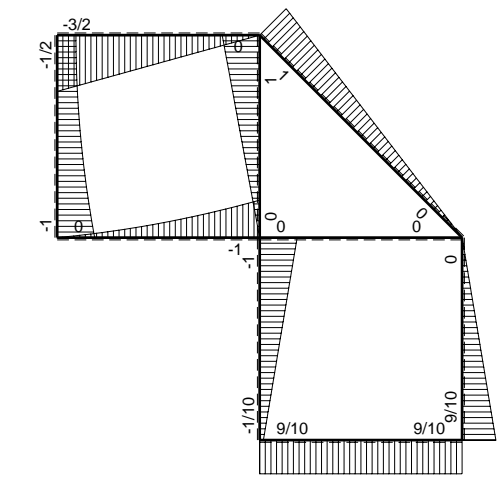

⊕ ⊖ F_b

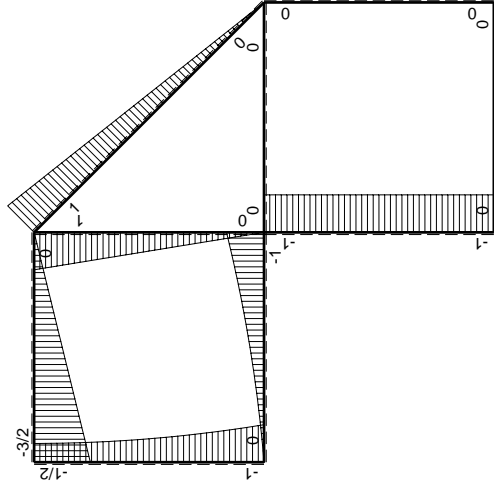
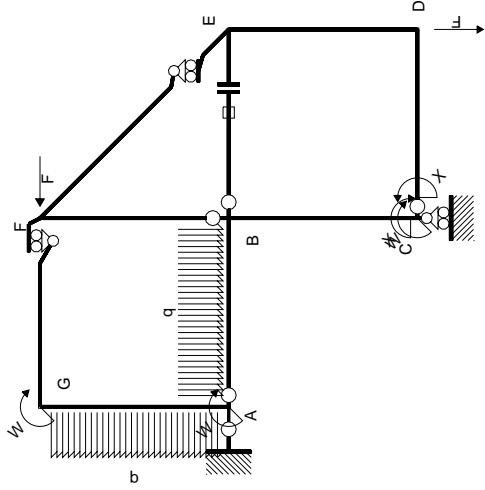

Schema di calcolo iperstatico

M_0 flessione da carichi assegnati

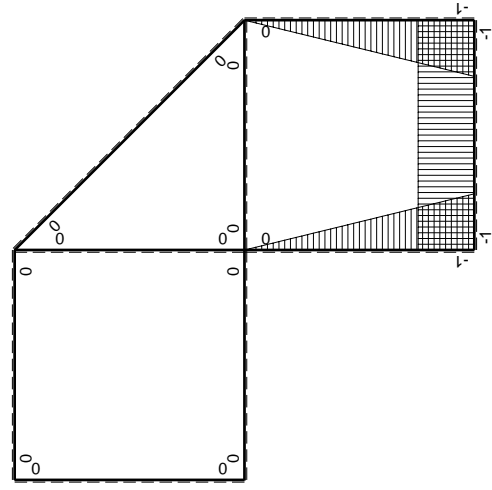

M_x flessione da iperstatica $X=1$

Quadro contributi PLV per iperstatica $X=W_{cd}$

\rightarrow	$M_x(x)$	$M_0(x)$	$M_x M_0$	$M_x M_x$	$\int M_x M_0 / E J dx$	$\int X M_x M_x / E J dx$
AB b	0	$-1/2Fx - 1/2qx^2$	0	0	0	0
BA b	0	$Fb - 3/2Fx + 1/2qx^2$	0	0	0	0
BC b	$-x/b$	$-Fb$	Fx	x^2/b^2	$1/2Fb^2/EJ$	$1/3Xb/EJ$
CB b	$1-x/b$	Fb	$Fb-Fx$	$1-2x/b+x^2/b^2$		
CD b	-1	0	0	1	0	Xb/EJ
DC b	1	0	0	1	0	
DE b	$-1+x/b$	0	0	$1-2x/b+x^2/b^2$	0	$1/3Xb/EJ$
ED b	x/b	0	0	x^2/b^2	0	0
EF $\sqrt{2}b$	0	$\sqrt{2}/2Fx$	0	0	0	0
FG b	0	$-3/2Fx$	0	0	0	0
GF b	0	$3/2Fb - 3/2Fx$	0	0	0	0
GA b	0	$-1/2Fb - 1/2qx^2$	0	0	0	0
AG b	0	$Fb-Fx + 1/2qx^2$	0	0	0	0
FB b	0	$Fb-Fx$	0	0	0	0
BF b	0	$-Fx$	0	0	0	0
BE b	0	0	0	0	0	0
EB b	0	0	0	0	0	0
BE	elongazione asta $N_{1, BE} \epsilon_{BE} L_{BE}$				Fb^2/EJ	
	totali				$3/2Fb^2/EJ$	$5/3Xb/EJ$
	iperstatica $X=W_{cd}$					$-9/10Fb$

Sviluppi di calcolo iperstatica

$$L_{BC}^{xx} = \int_0^b (x^2/b^2) 1/EJ dx = [1/3 x^3/b^2]_0^b 1/EJ$$

$$= (1/3 b) 1/EJ = 1/3 b/EJ$$

$$L_{CB}^{xx} = \int_0^b (1 - 2x/b + x^2/b^2) 1/EJ dx = [x - x^2/b + 1/3 x^3/b^2]_0^b 1/EJ$$

$$= (b - b + 1/3 b) 1/EJ = 1/3 b/EJ$$

$$L_{CD}^{xx} = \int_0^b (1) 1/EJ dx = [x]_0^b 1/EJ$$

$$= (b) 1/EJ = b/EJ$$

$$L_{DC}^{xx} = \int_0^b (1) 1/EJ dx = [x]_0^b 1/EJ$$

$$= (b) 1/EJ = b/EJ$$

$$L_{DE}^{xx} = \int_0^b (1 - 2x/b + x^2/b^2) 1/EJ dx = [x - x^2/b + 1/3 x^3/b^2]_0^b 1/EJ$$

$$= (b - b + 1/3 b) 1/EJ = 1/3 b/EJ$$

$$L_{ED}^{xx} = \int_0^b (x^2/b^2) 1/EJ dx = [1/3 x^3/b^2]_0^b 1/EJ$$

$$= (1/3 b) 1/EJ = 1/3 b/EJ$$

$$L_{BC}^{xo} = \int_0^b (x/b) Fb 1/EJ dx = [1/2 x^2/b]_0^b Fb 1/EJ$$

$$= (1/2 b) Fb 1/EJ = 1/2 Fb^2/EJ$$

$$L_{CB}^{xo} = \int_0^b (1 - x/b) Fb 1/EJ dx = [x - 1/2 x^2/b]_0^b Fb 1/EJ$$

$$= (b - 1/2 b) Fb 1/EJ = 1/2 Fb^2/EJ$$

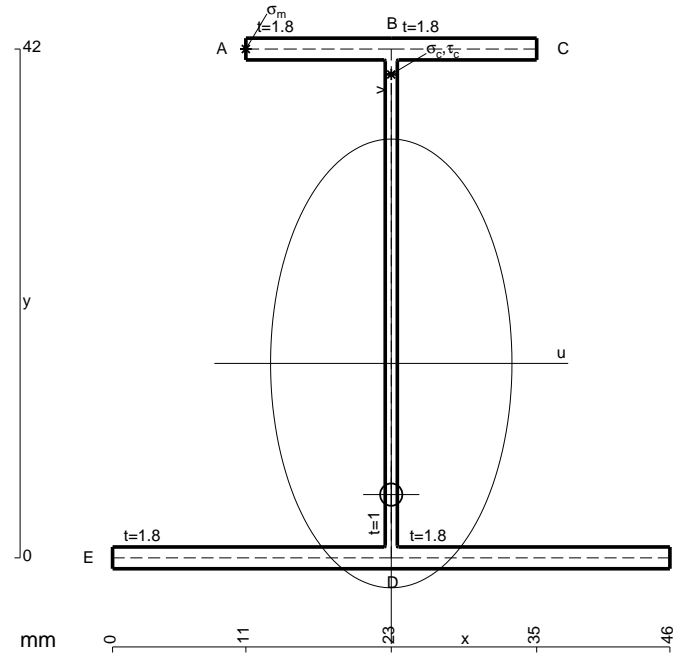

- A = 168. mm²
- J_u = 57624. mm⁴
- J_v = 16674. mm⁴
- J_i = 150.1 mm⁴
- y_o = -10.83 mm
- y_g = 16.05 mm
- T_y = -1005. N
- M_x = -482400. Nmm
- x_m = 11. mm
- y_m = 42. mm
- u_m = -12. mm
- v_m = 25.95 mm
- σ_m = -Mv/J_u = 217.2 N/mm²
- x_c = 23. mm
- y_c = 42. mm
- v_c = 25.95 mm
- σ_c = -Mv/J_u = 217.2 N/mm²
- τ_c = TS/tJ_u = 19.55 N/mm²
- τ_g = TS/tJ_u = 19.55 N/mm²
- t_c = 670. mm
- σ_o = √σ²+3τ² = 219.9 N/mm²

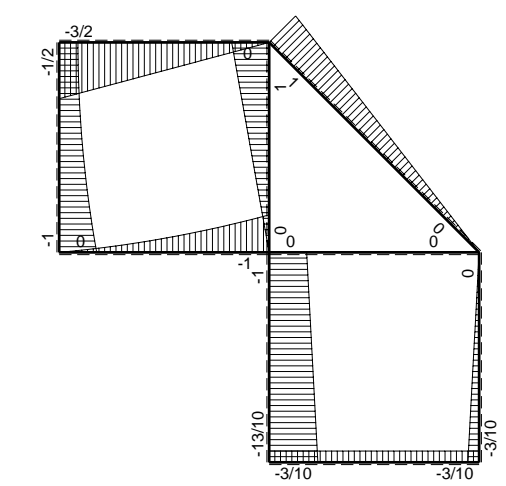
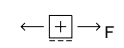
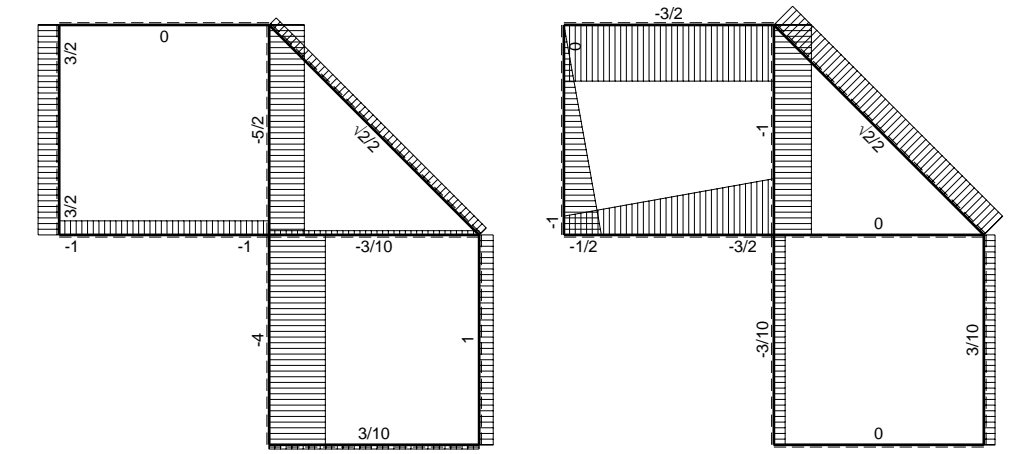
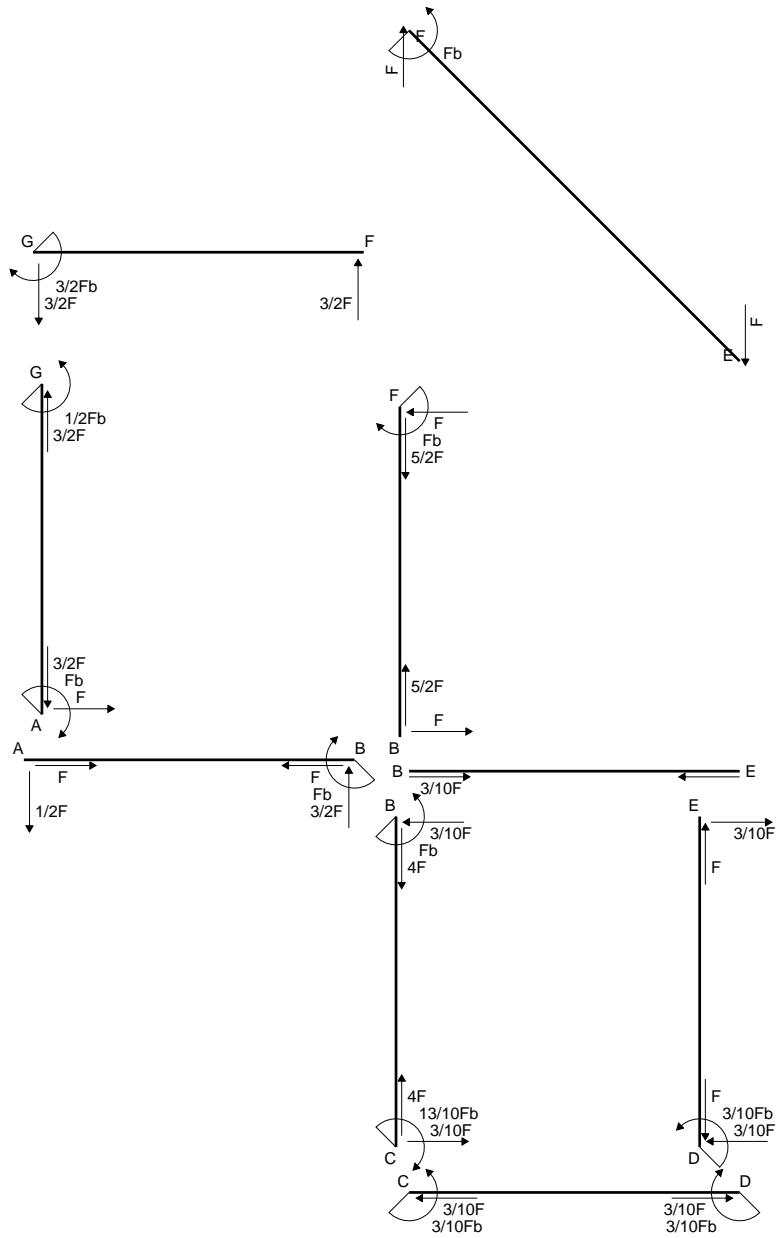

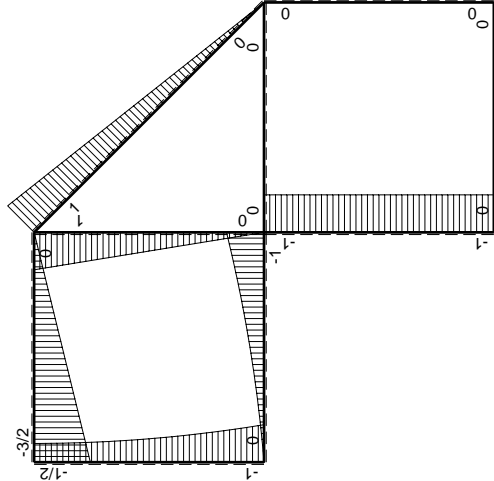
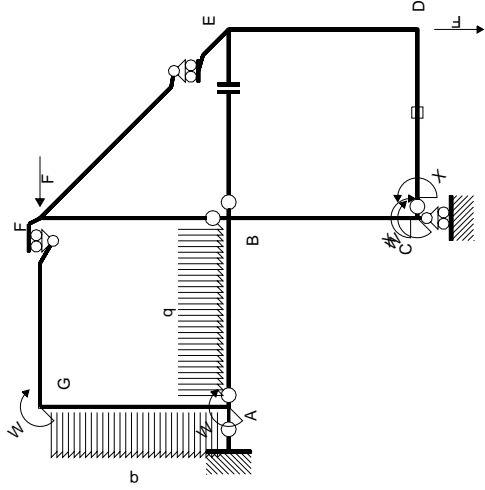

Schema di calcolo iperstatico

M_0 flessione da carichi assegnati

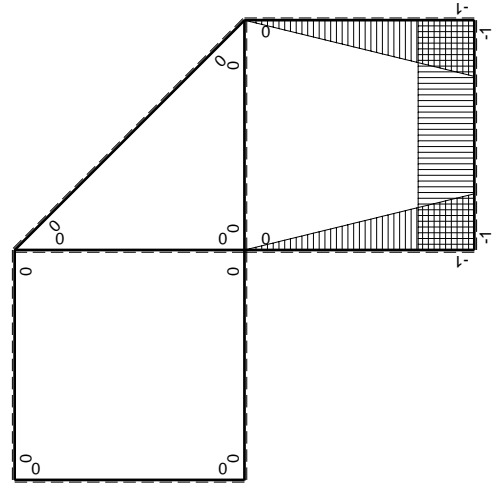

M_x flessione da iperstatica $X=1$

Quadro contribuiti PLV per iperstatica $X=W_{CD}$

\rightarrow	$M_x(x)$	$M_0(x)$	$M_x M_0$	$M_x M_x$	$\int M_x M_0 / E J dx$	$\int X M_x M_x / E J dx$
AB b	0	$-1/2Fx - 1/2qx^2$	0	0	0	0
BA b	0	$Fb - 3/2Fx + 1/2qx^2$	0	0	0	0
BC b	$-x/b$	$-Fb$	Fx	x^2/b^2	$1/2Fb^2/EJ$	$1/3Xb/EJ$
CB b	$1-x/b$	Fb	$Fb-Fx$	$1-2x/b+x^2/b^2$		
CD b	-1	0	0	1	0	Xb/EJ
DC b	1	0	0	1	0	
DE b	$-1+x/b$	0	0	$1-2x/b+x^2/b^2$	0	$1/3Xb/EJ$
ED b	x/b	0	0	x^2/b^2	0	0
EF $\sqrt{2}b$	0	$\sqrt{2}/2Fx$	0	0	0	0
FG b	0	$-3/2Fx$	0	0	0	0
GF b	0	$3/2Fb - 3/2Fx$	0	0	0	0
GA b	0	$-1/2Fb - 1/2qx^2$	0	0	0	0
AG b	0	$Fb-Fx + 1/2qx^2$	0	0	0	0
FB b	0	$Fb-Fx$	0	0	0	0
BF b	0	$-Fx$	0	0	0	0
BE b	0	0	0	0	0	0
EB b	0	0	0	0	0	0
CD	elongazione asta $N_{1,CD} \epsilon_{CD} L_{CD}$				$-Fb^2/EJ$	
	totali				$-1/2Fb^2/EJ$	$5/3Xb/EJ$
	iperstatica $X=W_{CD}$				$3/10Fb$	

Sviluppi di calcolo iperstatica

$$L_{BC}^{xx} = \int_0^b (x^2/b^2) 1/EJ dx = [1/3 x^3/b^2]_0^b 1/EJ$$

$$= (1/3 b) 1/EJ = 1/3 b/EJ$$

$$L_{CB}^{xx} = \int_0^b (1 - 2x/b + x^2/b^2) 1/EJ dx = [x - x^2/b + 1/3 x^3/b^2]_0^b 1/EJ$$

$$= (b - b + 1/3 b) 1/EJ = 1/3 b/EJ$$

$$L_{CD}^{xx} = \int_0^b (1) 1/EJ dx = [x]_0^b 1/EJ$$

$$= (b) 1/EJ = b/EJ$$

$$L_{DC}^{xx} = \int_0^b (1) 1/EJ dx = [x]_0^b 1/EJ$$

$$= (b) 1/EJ = b/EJ$$

$$L_{DE}^{xx} = \int_0^b (1 - 2x/b + x^2/b^2) 1/EJ dx = [x - x^2/b + 1/3 x^3/b^2]_0^b 1/EJ$$

$$= (b - b + 1/3 b) 1/EJ = 1/3 b/EJ$$

$$L_{ED}^{xx} = \int_0^b (x^2/b^2) 1/EJ dx = [1/3 x^3/b^2]_0^b 1/EJ$$

$$= (1/3 b) 1/EJ = 1/3 b/EJ$$

$$L_{BC}^{xo} = \int_0^b (x/b) Fb 1/EJ dx = [1/2 x^2/b]_0^b Fb 1/EJ$$

$$= (1/2 b) Fb 1/EJ = 1/2 Fb^2/EJ$$

$$L_{CB}^{xo} = \int_0^b (1 - x/b) Fb 1/EJ dx = [x - 1/2 x^2/b]_0^b Fb 1/EJ$$

$$= (b - 1/2 b) Fb 1/EJ = 1/2 Fb^2/EJ$$

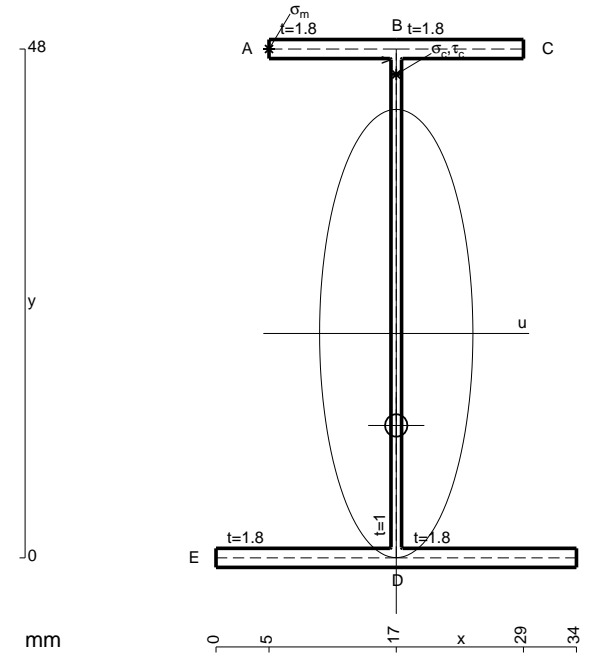

- A = 152.4 mm²
- J_u = 68126. mm⁴
- J_v = 7969. mm⁴
- J_i = 128.8 mm⁴
- y_o = -8.676 mm
- y_g = 21.17 mm
- T_y = -1005. N
- M_x = -582900. Nmm
- x_m = 5. mm
- y_m = 48. mm
- u_m = -12. mm
- v_m = 26.83 mm
- σ_m = -M_y/J_u = 229.6 N/mm²
- x_c = 17. mm
- y_c = 48. mm
- v_c = 26.83 mm
- σ_c = -M_y/J_u = 229.6 N/mm²
- τ_c = T_S/tJ_u = 17.1 N/mm²
- τ_g = T_S/tJ_u = 17.1 N/mm²
- t_c = 670. mm
- σ_o = √(σ²+3τ²) = 231.5 N/mm²

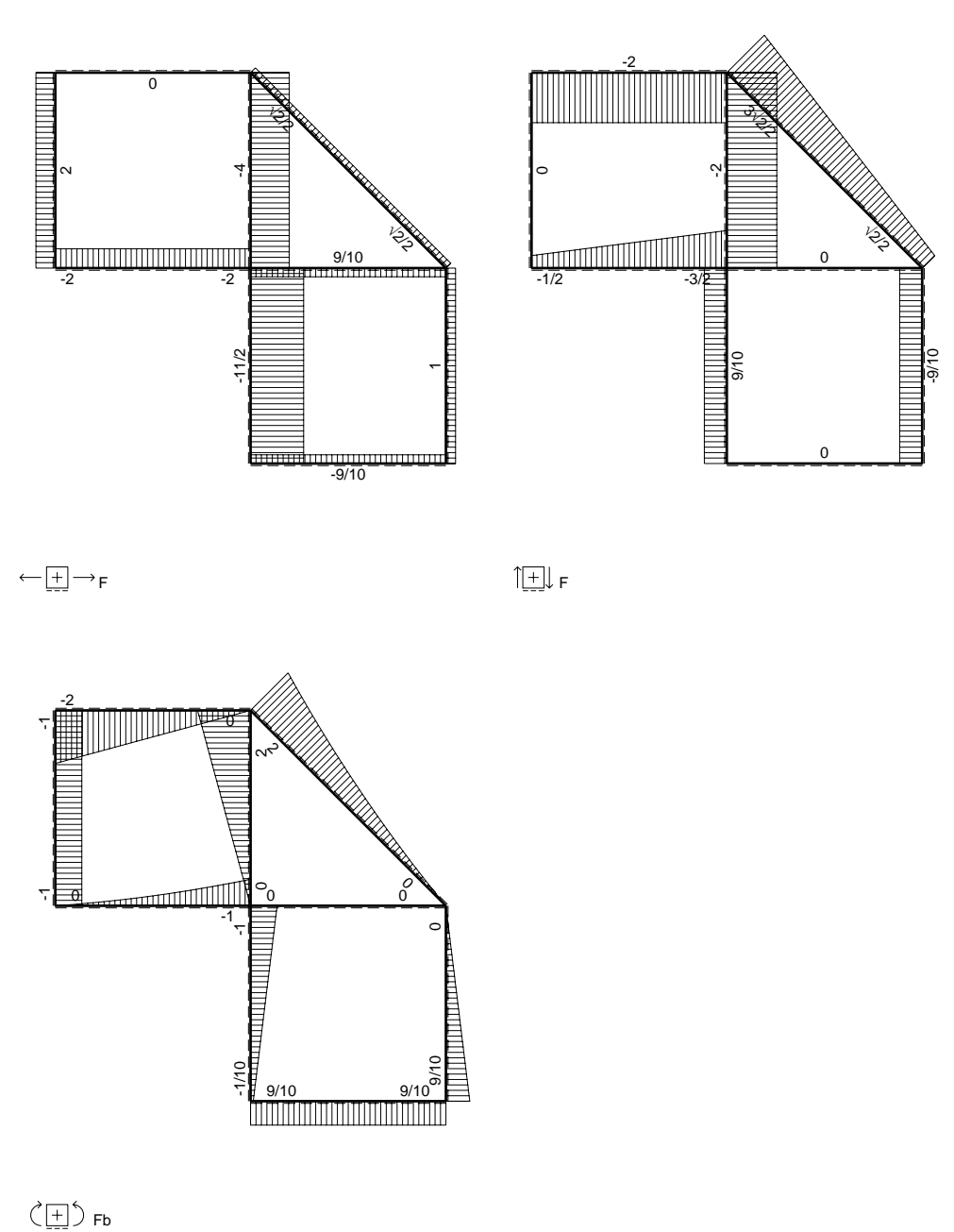
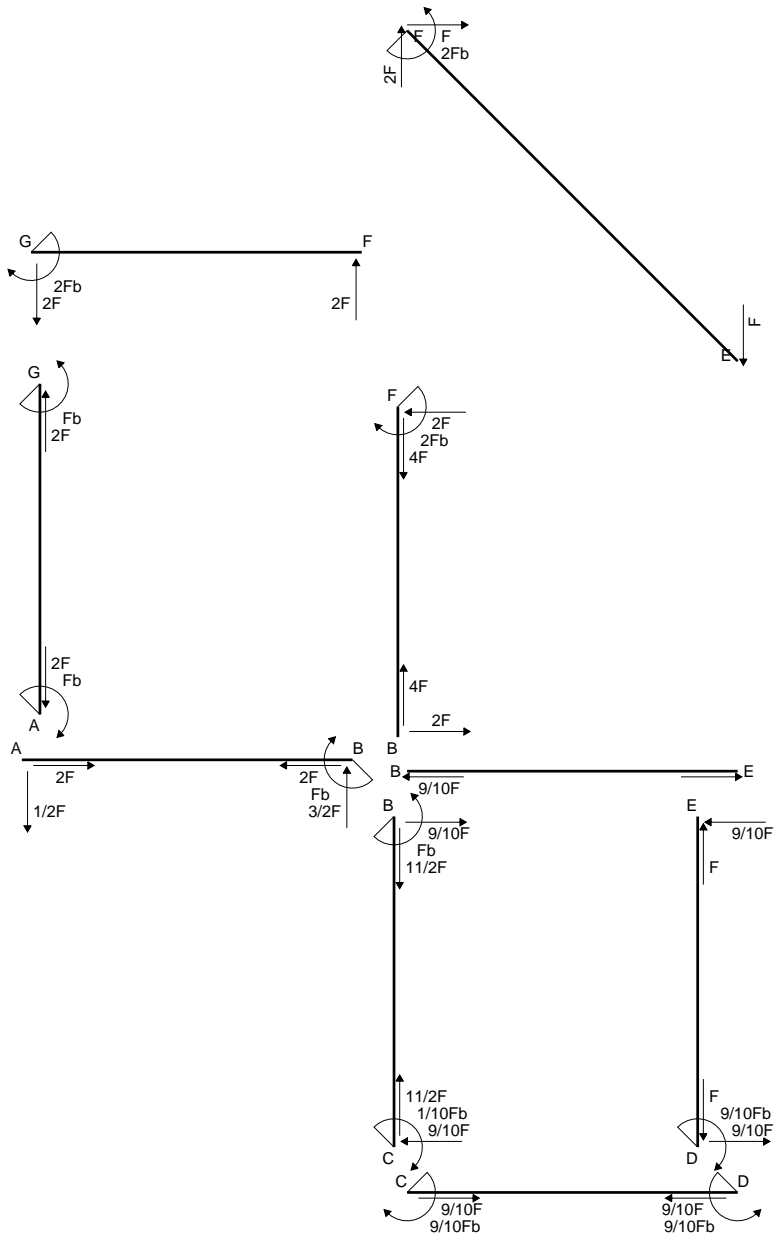

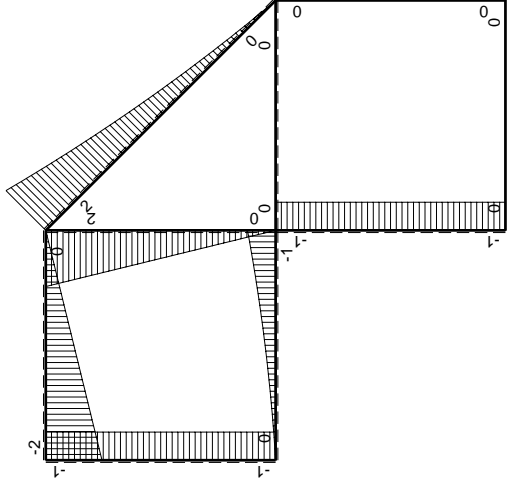
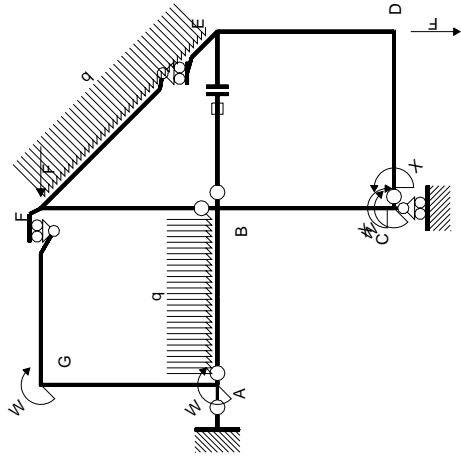

Schema di calcolo iperstatico

M_0 flessione da carichi assegnati

Quadro contribuiti PLV per iperstatica $X=W_{cd}$

\rightarrow	$M_x(x)$	$M_0(x)$	$M_x M_0$	$M_x M_x$	$\int M_x M_0 / E J dx$	$\int X M_x M_x / E J dx$
AB b	0	$-1/2Fx - 1/2qx^2$	0	0	0	0
BA b	0	$Fb - 3/2Fx + 1/2qx^2$	0	0	0	0
BC b	$-x/b$	$-Fb$	Fx	x^2/b^2	$1/2Fb^2/EJ$	$1/3Xb/EJ$
CB b	$1-x/b$	Fb	$Fb-Fx$	$1-2x/b+x^2/b^2$		
CD b	-1	0	0	1	0	Xb/EJ
DC b	1	0	0	1	0	
DE b	$-1+x/b$	0	0	$1-2x/b+x^2/b^2$	0	$1/3Xb/EJ$
ED b	x/b	0	0	x^2/b^2	0	0
EF $\sqrt{2}b$	0	$\sqrt{2}/2Fx + 1/2qx^2$	0	0	0	0
FG b	0	$-2Fx$	0	0	0	0
GF b	0	$2Fb-2Fx$	0	0	0	0
GA b	0	$-Fb$	0	0	0	0
AG b	0	Fb	0	0	0	0
FB b	0	$2Fb-2Fx$	0	0	0	0
BF b	0	$-2Fx$	0	0	0	0
BE b	0	0	0	0	0	0
EB b	0	0	0	0	0	0
BE	elongazione asta $N_{1, BE} \epsilon_{BE} L_{BE}$				Fb^2/EJ	
	totali				$3/2Fb^2/EJ$	$5/3Xb/EJ$
	iperstatica $X=W_{cd}$				$-9/10Fb$	

Sviluppi di calcolo iperstatica

M_x flessione da iperstatica $X=1$

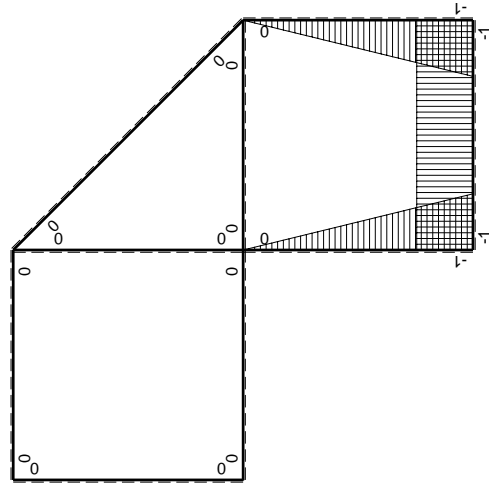

$$L_{BC}^{xx} = \int_0^b (x^2/b^2) 1/EJ dx = [1/3 x^3/b^2]_0^b 1/EJ$$

$$= (1/3 b) 1/EJ = 1/3 b/EJ$$

$$L_{CB}^{xx} = \int_0^b (1 - 2x/b + x^2/b^2) 1/EJ dx = [x - x^2/b + 1/3 x^3/b^2]_0^b 1/EJ$$

$$= (b - b + 1/3 b) 1/EJ = 1/3 b/EJ$$

$$L_{CD}^{xx} = \int_0^b (1) 1/EJ dx = [x]_0^b 1/EJ$$

$$= (b) 1/EJ = b/EJ$$

$$L_{DC}^{xx} = \int_0^b (1) 1/EJ dx = [x]_0^b 1/EJ$$

$$= (b) 1/EJ = b/EJ$$

$$L_{DE}^{xx} = \int_0^b (1 - 2x/b + x^2/b^2) 1/EJ dx = [x - x^2/b + 1/3 x^3/b^2]_0^b 1/EJ$$

$$= (b - b + 1/3 b) 1/EJ = 1/3 b/EJ$$

$$L_{ED}^{xx} = \int_0^b (x^2/b^2) 1/EJ dx = [1/3 x^3/b^2]_0^b 1/EJ$$

$$= (1/3 b) 1/EJ = 1/3 b/EJ$$

$$L_{BC}^{xo} = \int_0^b (x/b) Fb 1/EJ dx = [1/2 x^2/b]_0^b Fb 1/EJ$$

$$= (1/2 b) Fb 1/EJ = 1/2 Fb^2/EJ$$

$$L_{CB}^{xo} = \int_0^b (1 - x/b) Fb 1/EJ dx = [x - 1/2 x^2/b]_0^b Fb 1/EJ$$

$$= (b - 1/2 b) Fb 1/EJ = 1/2 Fb^2/EJ$$

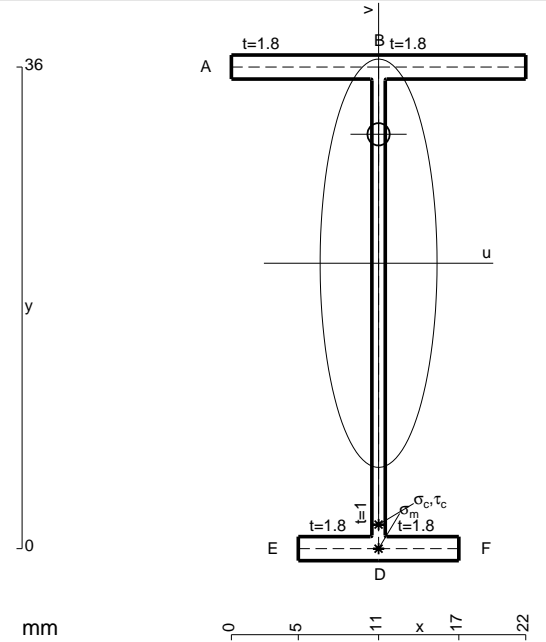

- A = 97.2 mm²
- J_u = 22637. mm⁴
- J_v = 1856. mm⁴
- J_t = 78.1 mm⁴
- y_o = 9.64 mm
- y_g = 21.33 mm
- N = 183.8 N
- T_y = 551.5 N
- M_x = 244400. Nmm
- x_m = 11. mm
- v_m = -21.33 mm
- σ_m = N/A-Mv/J_u = 232.2 N/mm²
- y_c = 3. mm
- u_c = -11. mm
- v_c = -18.33 mm
- σ_c = N/A-Mv/J_u = 232.2 N/mm²
- τ_c = TS⁺/tJ_u = 11.23 N/mm²
- τ_g = TS⁺/tJ_u = 11.23 N/mm²
- t_c = 260. mm
- σ_o = √σ²+3τ² = 233. N/mm²

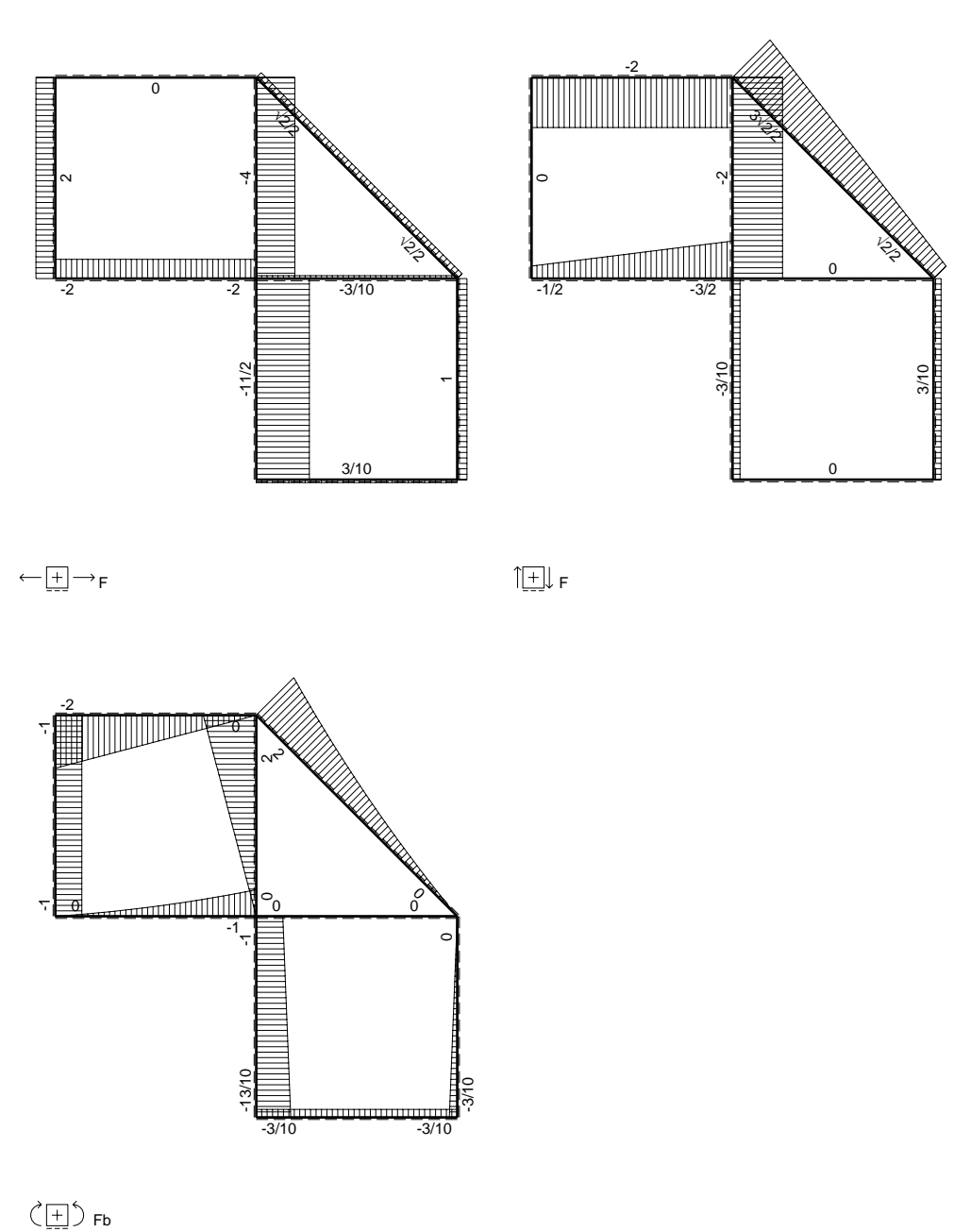
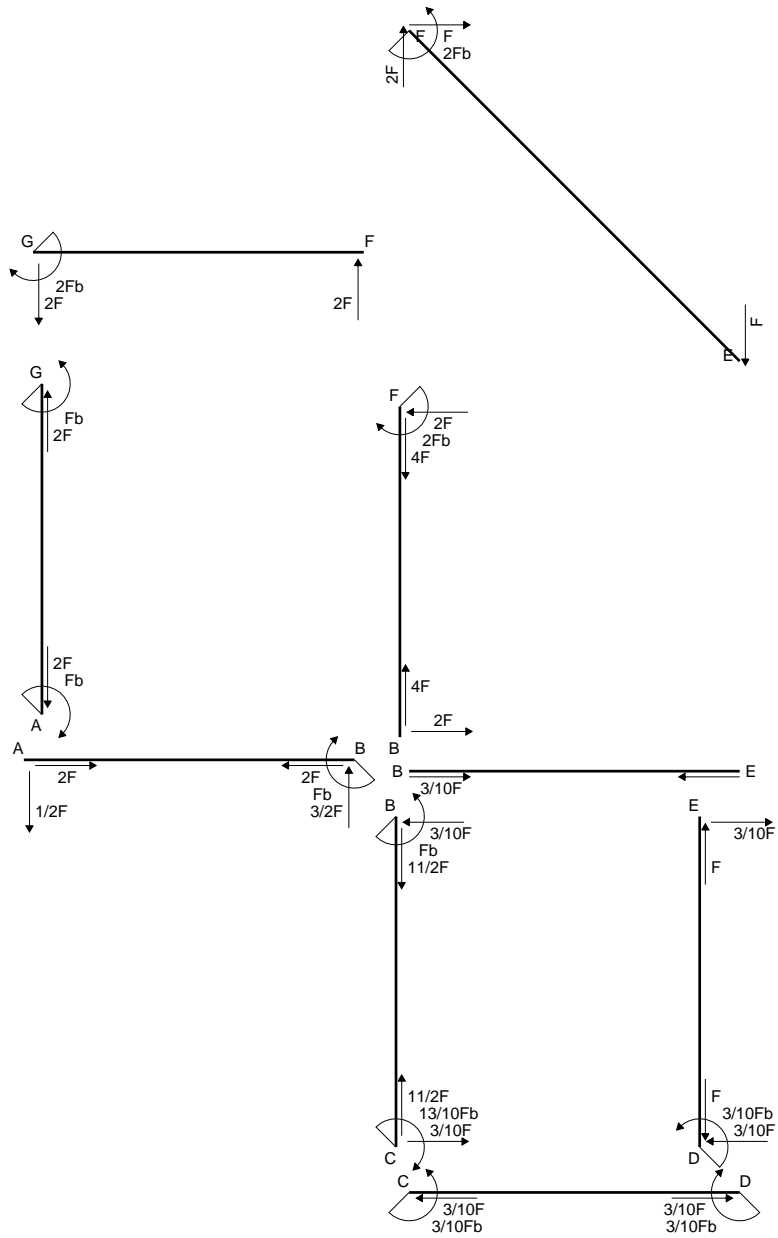

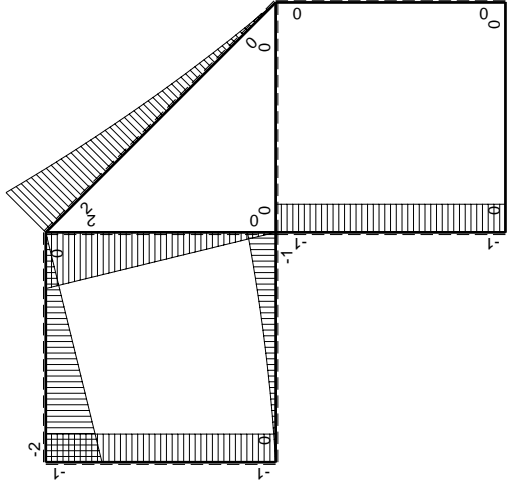
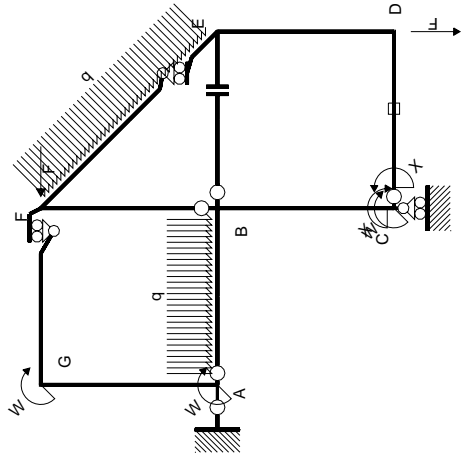

Schema di calcolo iperstatico

M_0 flessione da carichi assegnati

Quadro contribuiti PLV per iperstatica $X=W_{CD}$

\rightarrow	$M_x(x)$	$M_0(x)$	$M_x M_0$	$M_x M_x$	$\int M_x M_0 / E J dx$	$\int X M_x M_x / E J dx$
AB b	0	$-1/2Fx - 1/2qx^2$	0	0	0	0
BA b	0	$Fb - 3/2Fx + 1/2qx^2$	0	0	0	0
BC b	$-x/b$	$-Fb$	Fx	x^2/b^2	$1/2Fb^2/EJ$	$1/3Xb/EJ$
CB b	$1-x/b$	Fb	$Fb-Fx$	$1-2x/b+x^2/b^2$		
CD b	-1	0	0	1	0	Xb/EJ
DC b	1	0	0	1	0	
DE b	$-1+x/b$	0	0	$1-2x/b+x^2/b^2$	0	$1/3Xb/EJ$
ED b	x/b	0	0	x^2/b^2	0	0
EF $\sqrt{2}b$	0	$\sqrt{2}/2Fx + 1/2qx^2$	0	0	0	0
FG b	0	$-2Fx$	0	0	0	0
GF b	0	$2Fb-2Fx$	0	0	0	0
GA b	0	$-Fb$	0	0	0	0
AG b	0	Fb	0	0	0	0
FB b	0	$2Fb-2Fx$	0	0	0	0
BF b	0	$-2Fx$	0	0	0	0
BE b	0	0	0	0	0	0
EB b	0	0	0	0	0	0
CD	elongazione asta $N_{1,CD} \epsilon_{CD} L_{CD}$				$-Fb^2/EJ$	
	totali				$-1/2Fb^2/EJ$	$5/3Xb/EJ$
	iperstatica $X=W_{CD}$				$3/10Fb$	

Sviluppi di calcolo iperstatica

M_x flessione da iperstatica $X=1$

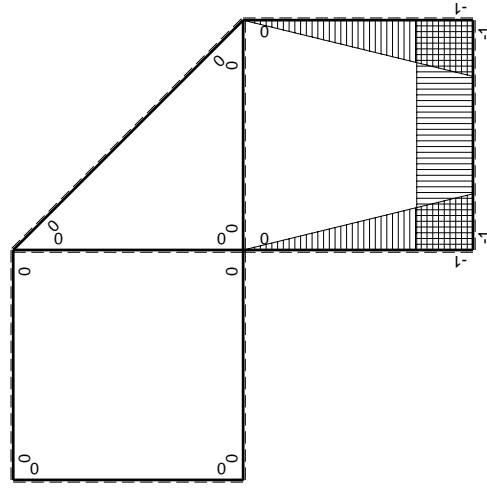

$$L_{BC}^{xx} = \int_0^b (x^2/b^2) 1/EJ dx = [1/3 x^3/b^2]_0^b 1/EJ$$

$$= (1/3 b) 1/EJ = 1/3 b/EJ$$

$$L_{CB}^{xx} = \int_0^b (1 - 2x/b + x^2/b^2) 1/EJ dx = [x - x^2/b + 1/3 x^3/b^2]_0^b 1/EJ$$

$$= (b - b + 1/3 b) 1/EJ = 1/3 b/EJ$$

$$L_{CD}^{xx} = \int_0^b (1) 1/EJ dx = [x]_0^b 1/EJ$$

$$= (b) 1/EJ = b/EJ$$

$$L_{DC}^{xx} = \int_0^b (1) 1/EJ dx = [x]_0^b 1/EJ$$

$$= (b) 1/EJ = b/EJ$$

$$L_{DE}^{xx} = \int_0^b (1 - 2x/b + x^2/b^2) 1/EJ dx = [x - x^2/b + 1/3 x^3/b^2]_0^b 1/EJ$$

$$= (b - b + 1/3 b) 1/EJ = 1/3 b/EJ$$

$$L_{ED}^{xx} = \int_0^b (x^2/b^2) 1/EJ dx = [1/3 x^3/b^2]_0^b 1/EJ$$

$$= (1/3 b) 1/EJ = 1/3 b/EJ$$

$$L_{BC}^{xo} = \int_0^b (x/b) Fb 1/EJ dx = [1/2 x^2/b]_0^b Fb 1/EJ$$

$$= (1/2 b) Fb 1/EJ = 1/2 Fb^2/EJ$$

$$L_{CB}^{xo} = \int_0^b (1 - x/b) Fb 1/EJ dx = [x - 1/2 x^2/b]_0^b Fb 1/EJ$$

$$= (b - 1/2 b) Fb 1/EJ = 1/2 Fb^2/EJ$$

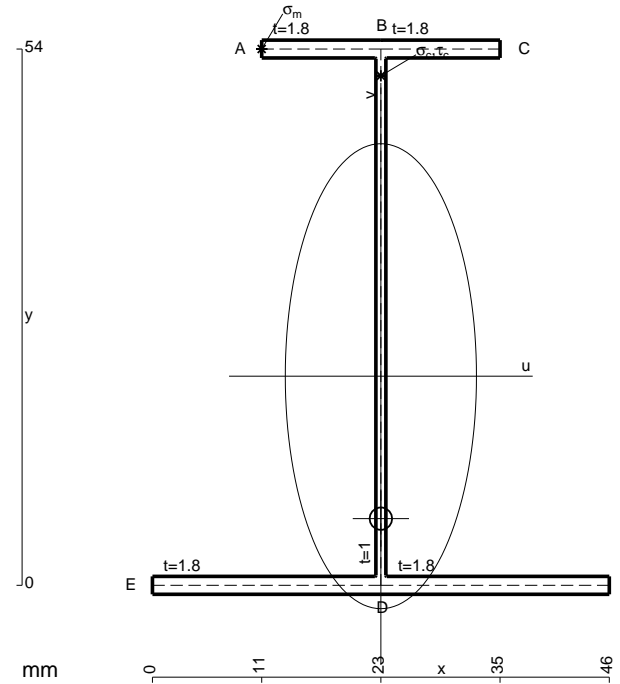

- A = 180. mm²
- J_u = 98625. mm⁴
- J_v = 16674. mm⁴
- J_i = 154.1 mm⁴
- y_o = -14.34 mm
- y_g = 21.06 mm
- N = 275.8 N
- T_y = 827.3 N
- M_x = 592800. Nmm
- x_m = 11. mm
- y_m = 54. mm
- u_m = -12. mm
- v_m = 32.94 mm
- σ_m = N/A-Mv/J_u = -196.5 N/mm²
- x_c = 23. mm
- y_c = 54. mm
- v_c = 32.94 mm
- σ_c = N/A-Mv/J_u = -196.5 N/mm²
- τ_c = TS/tJ_u = 11.94 N/mm²
- τ_g = TS/tJ_u = 11.94 N/mm²
- t_c = 390. mm
- σ_o = √σ²+3τ² = 197.5 N/mm²

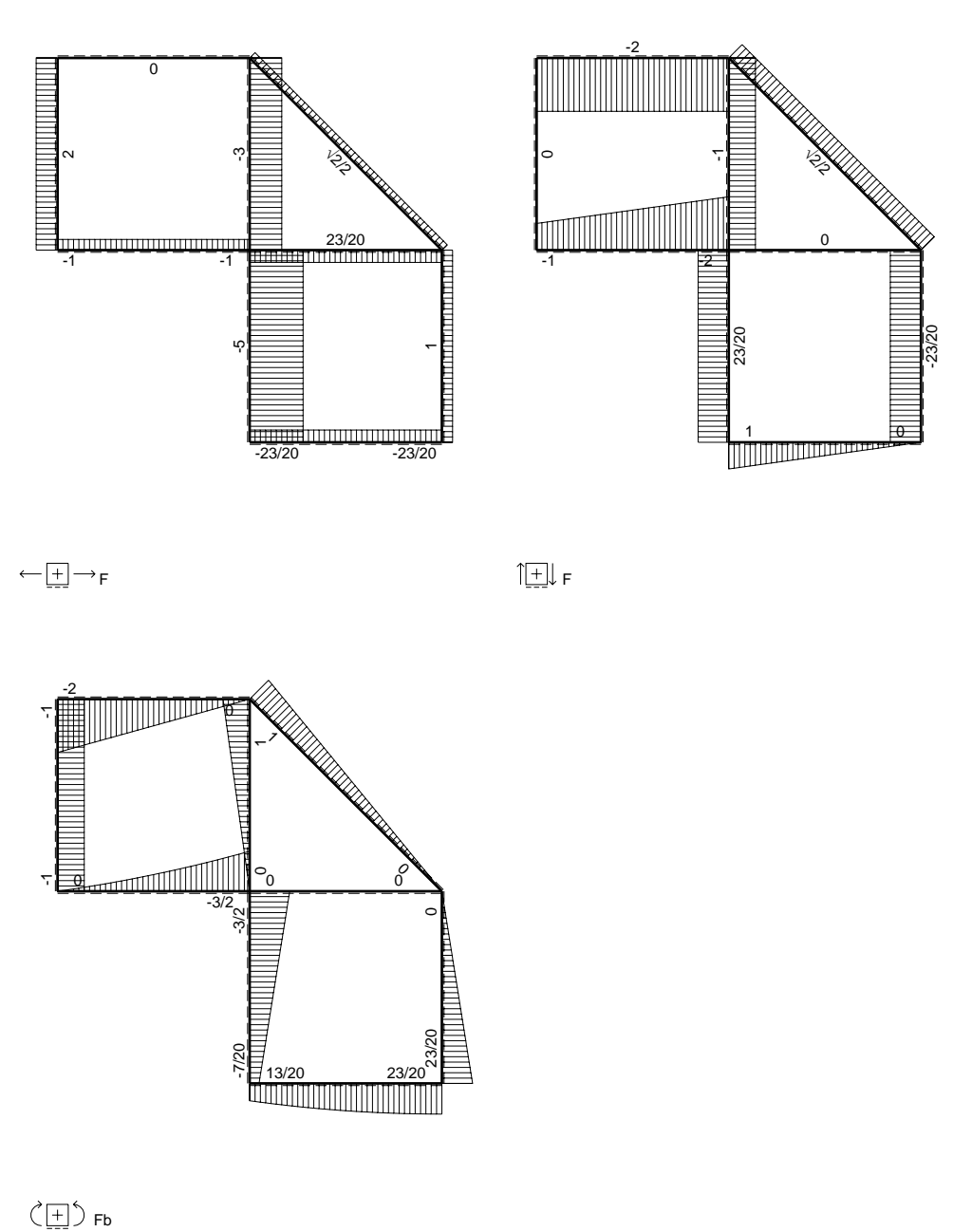
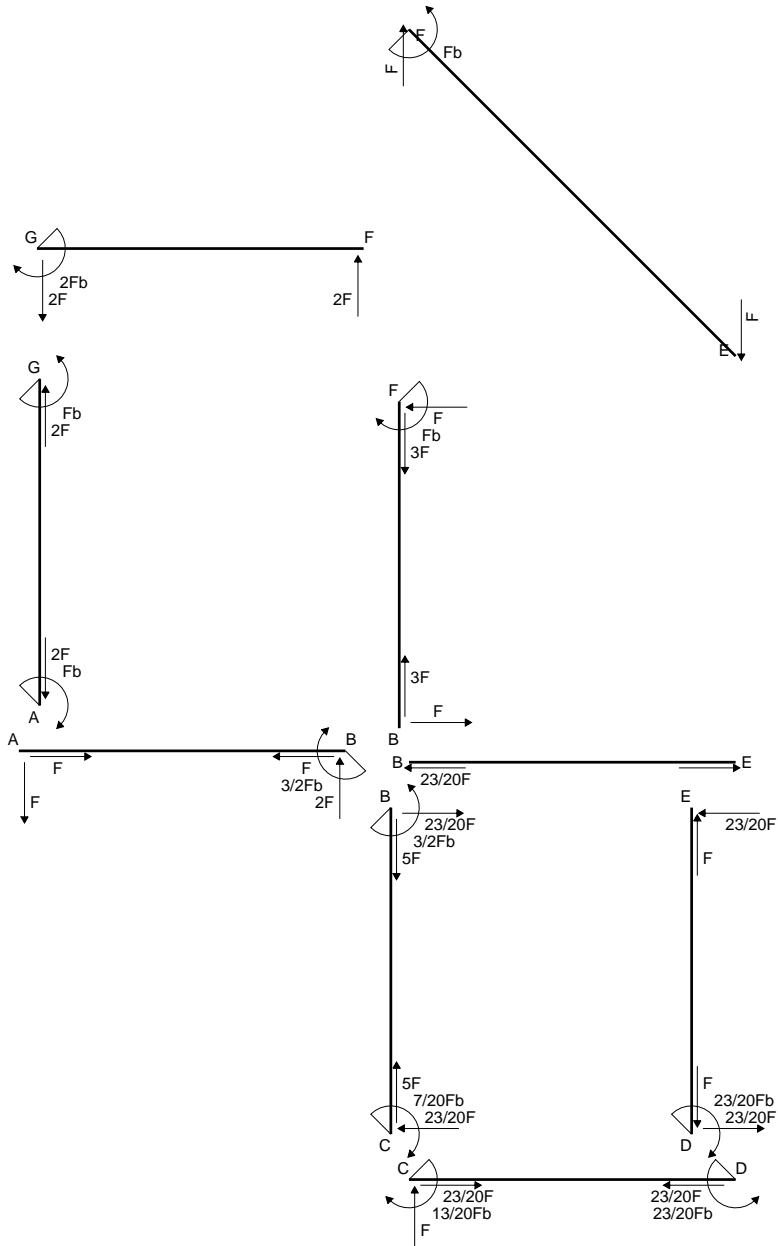

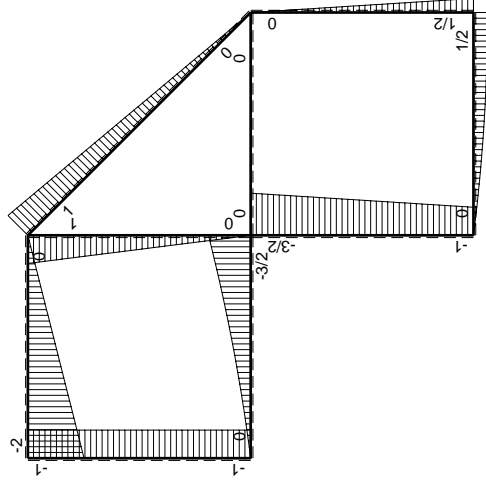
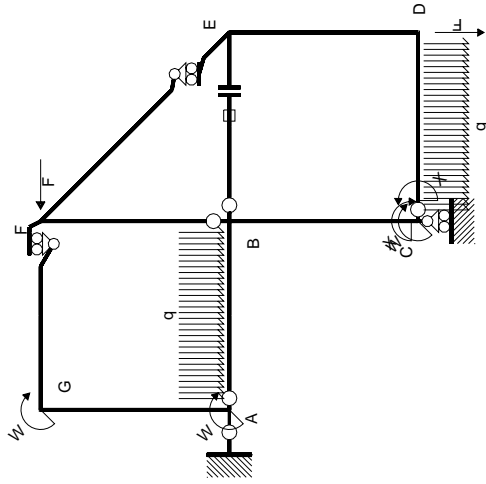

(\oplus) M_0 flessione da carichi assegnati

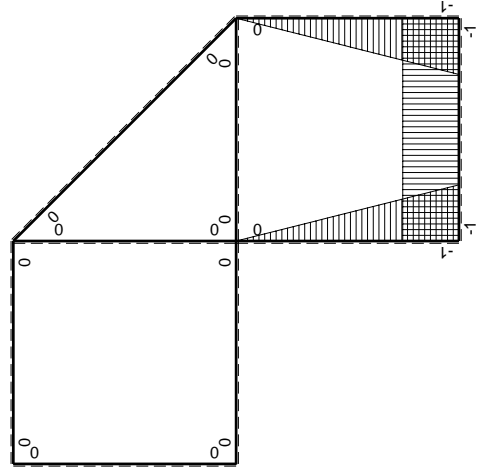

(\oplus) M_x flessione da iperstatica $X=1$

Quadro contribuiti PLV per iperstatica $X=W_{cd}$

\rightarrow	$M_x(x)$	$M_0(x)$	$M_x M_0$	$M_x M_x$	$\int M_x M_0 / EJ dx$	$\int X M_x M_x / EJ dx$
AB b	0	$-Fx - 1/2qx^2$	0	0	0	0
BA b	0	$3/2Fb - 2Fx + 1/2qx^2$	0	0	0	0
BC b	$-x/b$	$-3/2Fb + 1/2Fx$	$3/2Fx - 1/2Fx^2/b$	x^2/b^2	$7/12Fb^2/EJ$	$1/3Xb/EJ$
CB b	$1-x/b$	$Fb + 1/2Fx$	$Fb - 1/2Fx - 1/2Fx^2/b$	$1 - 2x/b + x^2/b^2$	$-1/3Fb^2/EJ$	Xb/EJ
CD b	-1	$Fx - 1/2qx^2$	$-Fx + 1/2Fx^2/b$	1	$-1/3Fb^2/EJ$	Xb/EJ
DC b	1	$-1/2Fb + 1/2qx^2$	$-1/2Fb + 1/2Fx^2/b$	1	$-1/3Fb^2/EJ$	Xb/EJ
DE b	$-1 + x/b$	$1/2Fb - 1/2Fx$	$-1/2Fb + Fx - 1/2Fx^2/b$	$1 - 2x/b + x^2/b^2$	$-1/6Fb^2/EJ$	$1/3Xb/EJ$
ED b	x/b	$-1/2Fx$	$-1/2Fx^2/b$	x^2/b^2	$-1/6Fb^2/EJ$	$1/3Xb/EJ$
EF $\sqrt{2}b$	0	$\sqrt{2}/2Fx$	0	0	0	0
FG b	0	$-2Fx$	0	0	0	0
GF b	0	$2Fb - 2Fx$	0	0	0	0
GA b	0	$-Fb$	0	0	0	0
AG b	0	Fb	0	0	0	0
FB b	0	$Fb - Fx$	0	0	0	0
BF b	0	$-Fx$	0	0	0	0
BE b	0	0	0	0	0	0
EB b	0	0	0	0	0	0
BE	elongazione asta $N_{1, BE}^E - L_{BE} - BE$				Fb^2/EJ	
	totali				$13/12Fb^2/EJ$	$5/3Xb/EJ$
	iperstatica $X=W_{cd}$				$-13/20Fb$	

Sviluppi di calcolo iperstatica

$$L_{BC}^{xx} = \int_0^b (x^2/b^2) 1/EJ dx = [1/3 x^3/b^2]_0^b 1/EJ$$

$$= (1/3 b) 1/EJ = 1/3 b/EJ$$

$$L_{CB}^{xx} = \int_0^b (1 - 2x/b + x^2/b^2) 1/EJ dx = [x - x^2/b + 1/3 x^3/b^2]_0^b 1/EJ$$

$$= (b - b + 1/3 b) 1/EJ = 1/3 b/EJ$$

$$L_{CD}^{xx} = \int_0^b (1) 1/EJ dx = [x]_0^b 1/EJ$$

$$= (b) 1/EJ = b/EJ$$

$$L_{DC}^{xx} = \int_0^b (1) 1/EJ dx = [x]_0^b 1/EJ$$

$$= (b) 1/EJ = b/EJ$$

$$L_{DE}^{xx} = \int_0^b (1 - 2x/b + x^2/b^2) 1/EJ dx = [x - x^2/b + 1/3 x^3/b^2]_0^b 1/EJ$$

$$= (b - b + 1/3 b) 1/EJ = 1/3 b/EJ$$

$$L_{ED}^{xx} = \int_0^b (x^2/b^2) 1/EJ dx = [1/3 x^3/b^2]_0^b 1/EJ$$

$$= (1/3 b) 1/EJ = 1/3 b/EJ$$

$$L_{BC}^{x_0} = \int_0^b (3/2 x/b - 1/2 x^2/b^2) Fb 1/EJ dx = [3/4 x^2/b - 1/6 x^3/b^2]_0^b Fb 1/EJ$$

$$= (3/4 b - 1/6 b) Fb 1/EJ = 7/12 Fb^2/EJ$$

$$L_{CB}^{x_0} = \int_0^b (1 - 1/2 x/b - 1/2 x^2/b^2) Fb 1/EJ dx = [x - 1/4 x^2/b - 1/6 x^3/b^2]_0^b Fb 1/EJ$$

$$= (b - 1/4 b - 1/6 b) Fb 1/EJ = 7/12 Fb^2/EJ$$

$$L_{CD}^{x_0} = \int_0^b (-x/b + 1/2 x^2/b^2) Fb 1/EJ dx = [-1/2 x^2/b + 1/6 x^3/b^2]_0^b Fb 1/EJ$$

$$= (-1/2 b + 1/6 b) Fb 1/EJ = -1/3 Fb^2/EJ$$

$$L_{DC}^{x_0} = \int_0^b (-1/2 + 1/2 x^2/b^2) Fb 1/EJ dx = [-1/2 x + 1/6 x^3/b^2]_0^b Fb 1/EJ$$

$$= (-1/2 b + 1/6 b) Fb 1/EJ = -1/3 Fb^2/EJ$$

$$L_{DE}^{x_0} = \int_0^b (-1/2 + x/b - 1/2 x^2/b^2) Fb 1/EJ dx = [-1/2 x + 1/2 x^2/b - 1/6 x^3/b^2]_0^b Fb 1/EJ$$

$$= (-1/2 b + 1/2 b - 1/6 b) Fb 1/EJ = -1/6 Fb^2/EJ$$

$$L_{ED}^{x_0} = \int_0^b (-1/2 x^2/b^2) Fb 1/EJ dx = [-1/6 x^3/b^2]_0^b Fb 1/EJ$$

$$= (-1/6 b) Fb 1/EJ = -1/6 Fb^2/EJ$$

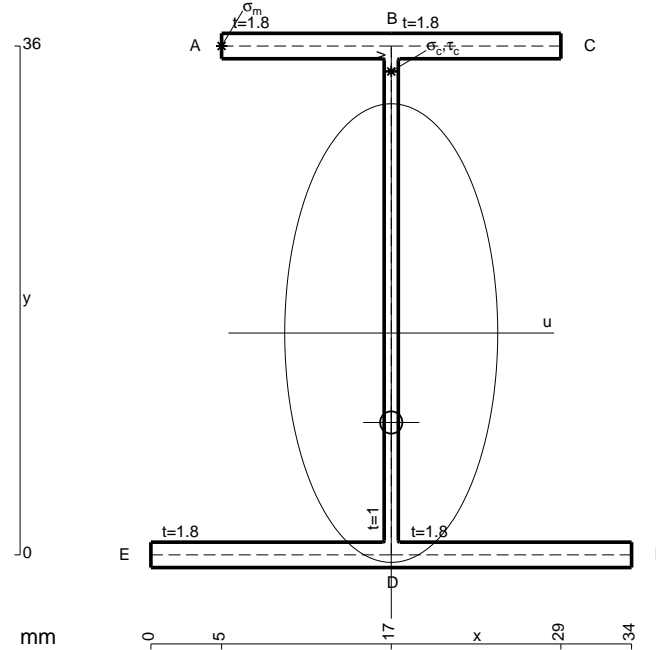

- A = 140.4 mm²
- J_u = 36966. mm⁴
- J_v = 7969. mm⁴
- J_i = 124.8 mm⁴
- y_o = -6.325 mm
- y_g = 15.69 mm
- T_y = -700. N
- M_x = -378000. Nmm
- x_m = 5. mm
- y_m = 36. mm
- u_m = -12. mm
- v_m = 20.31 mm
- σ_m = -Mv/J_u = 207.7 N/mm²
- x_c = 17. mm
- y_c = 36. mm
- v_c = 20.31 mm
- σ_c = -Mv/J_u = 207.7 N/mm²
- τ_c = TS/tJ_u = 16.61 N/mm²
- τ_g = TS'/tJ_u = 16.61 N/mm²
- t_c = 350. mm
- σ_o = √(σ²+3τ²) = 209.6 N/mm²

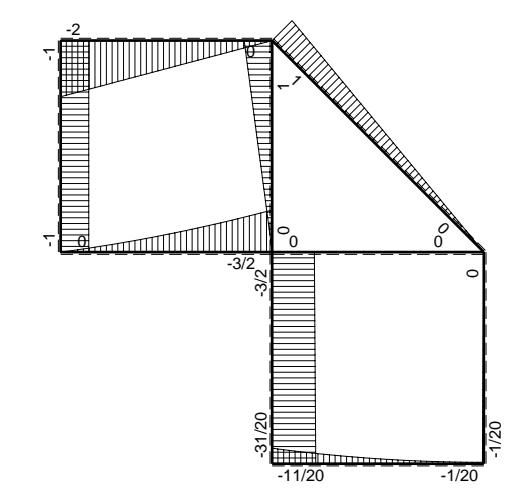
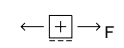
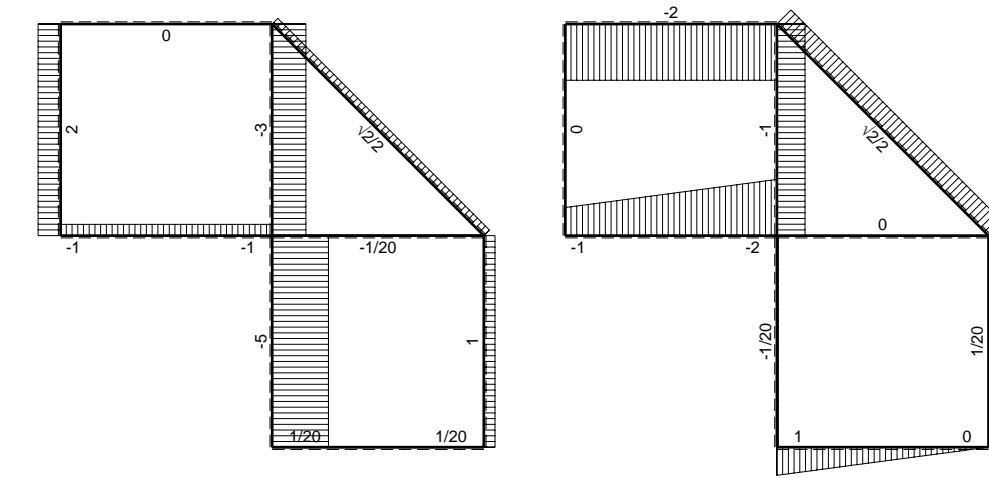
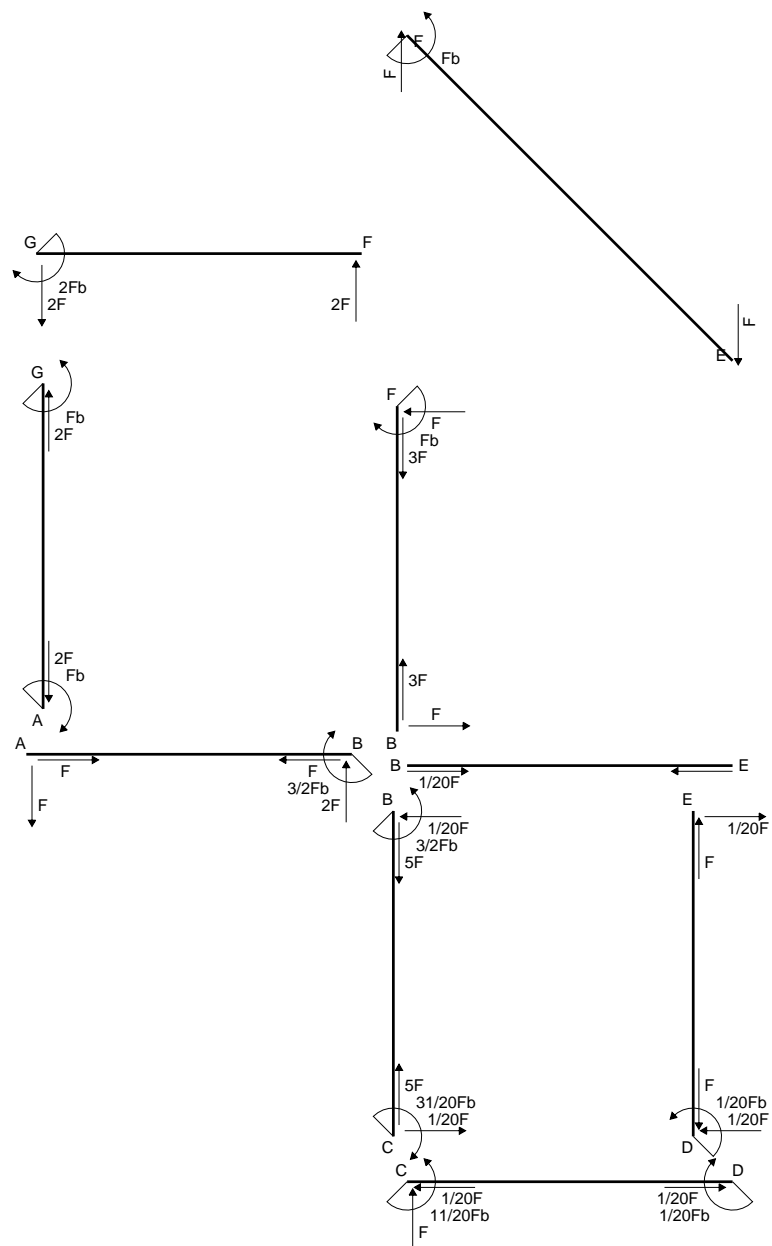

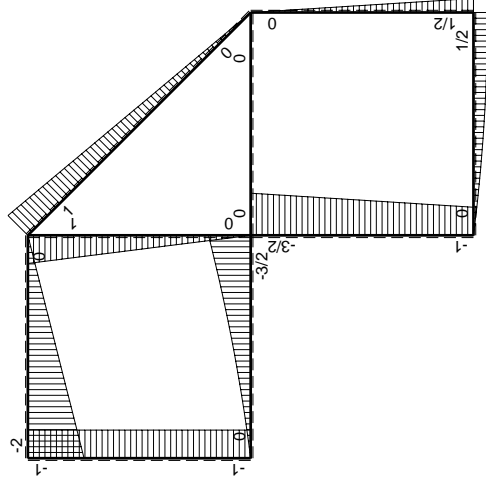
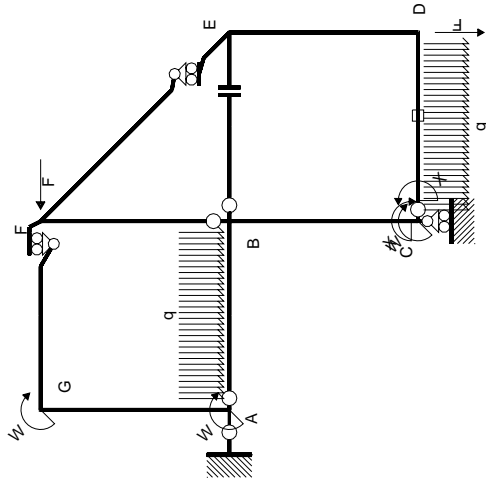

M_0 flessione da carichi assegnati

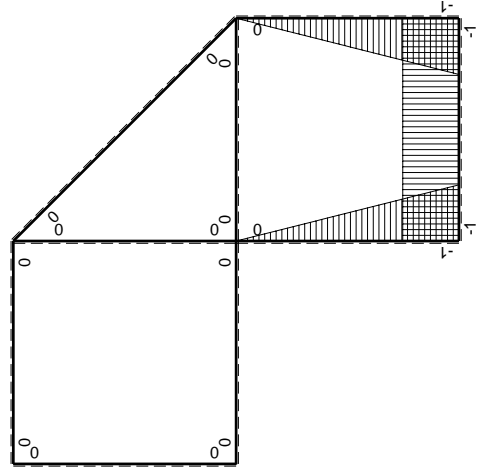

M_x flessione da iperstatica $X=1$

Quadro contribuiti PLV per iperstatica $X=W_{cd}$

\rightarrow	$M_x(x)$	$M_0(x)$	$M_x M_0$	$M_x M_x$	$\int M_x M_0 / EJ dx$	$\int X M_x M_x / EJ dx$
AB b	0	$-Fx - 1/2qx^2$	0	0	0	0
BA b	0	$3/2Fb - 2Fx + 1/2qx^2$	0	0	0	0
BC b	$-x/b$	$-3/2Fb + 1/2Fx$	$3/2Fx - 1/2Fx^2/b$	x^2/b^2	$7/12Fb^2/EJ$	$1/3Xb/EJ$
CB b	$1-x/b$	$Fb + 1/2Fx$	$Fb - 1/2Fx - 1/2Fx^2/b$	$1 - 2x/b + x^2/b^2$	$-1/3Fb^2/EJ$	Xb/EJ
CD b	-1	$Fx - 1/2qx^2$	$-Fx + 1/2Fx^2/b$	1	$-1/6Fb^2/EJ$	$1/3Xb/EJ$
DC b	1	$-1/2Fb + 1/2qx^2$	$-1/2Fb + 1/2Fx^2/b$	1	$-1/6Fb^2/EJ$	$1/3Xb/EJ$
DE b	$-1+x/b$	$1/2Fb - 1/2Fx$	$-1/2Fb + Fx - 1/2Fx^2/b$	$1 - 2x/b + x^2/b^2$	$-1/6Fb^2/EJ$	$1/3Xb/EJ$
ED b	x/b	$-1/2Fx$	$-1/2Fx^2/b$	x^2/b^2	0	0
EF $\sqrt{2}b$	0	$\sqrt{2}/2Fx$	0	0	0	0
FG b	0	$-2Fx$	0	0	0	0
GF b	0	$2Fb - 2Fx$	0	0	0	0
GA b	0	$-Fb$	0	0	0	0
AG b	0	Fb	0	0	0	0
FB b	0	$Fb - Fx$	0	0	0	0
BF b	0	$-Fx$	0	0	0	0
BE b	0	0	0	0	0	0
EB b	0	0	0	0	0	0
CD	elongazione asta $N_{1,cd} \epsilon_{cd} L_{cd}$				$-Fb^2/EJ$	
	totali				$-11/12Fb^2/EJ$	$5/3Xb/EJ$
	iperstatica $X=W_{cd}$				$11/20Fb$	

Sviluppi di calcolo iperstatica

$$L_{BC}^{xx} = \int_0^b (x^2/b^2) 1/EJ dx = [1/3 x^3/b^2]_0^b 1/EJ$$

$$= (1/3 b) 1/EJ = 1/3 b/EJ$$

$$L_{CB}^{xx} = \int_0^b (1 - 2x/b + x^2/b^2) 1/EJ dx = [x - x^2/b + 1/3 x^3/b^2]_0^b 1/EJ$$

$$= (b - b + 1/3 b) 1/EJ = 1/3 b/EJ$$

$$L_{CD}^{xx} = \int_0^b (1) 1/EJ dx = [x]_0^b 1/EJ$$

$$= (b) 1/EJ = b/EJ$$

$$L_{DC}^{xx} = \int_0^b (1) 1/EJ dx = [x]_0^b 1/EJ$$

$$= (b) 1/EJ = b/EJ$$

$$L_{DE}^{xx} = \int_0^b (1 - 2x/b + x^2/b^2) 1/EJ dx = [x - x^2/b + 1/3 x^3/b^2]_0^b 1/EJ$$

$$= (b - b + 1/3 b) 1/EJ = 1/3 b/EJ$$

$$L_{ED}^{xx} = \int_0^b (x^2/b^2) 1/EJ dx = [1/3 x^3/b^2]_0^b 1/EJ$$

$$= (1/3 b) 1/EJ = 1/3 b/EJ$$

$$L_{BC}^{xo} = \int_0^b (3/2 x/b - 1/2 x^2/b^2) Fb 1/EJ dx = [3/4 x^2/b - 1/6 x^3/b^2]_0^b Fb 1/EJ$$

$$= (3/4 b - 1/6 b) Fb 1/EJ = 7/12 Fb^2/EJ$$

$$L_{CB}^{xo} = \int_0^b (1 - 1/2 x/b - 1/2 x^2/b^2) Fb 1/EJ dx = [x - 1/4 x^2/b - 1/6 x^3/b^2]_0^b Fb 1/EJ$$

$$= (b - 1/4 b - 1/6 b) Fb 1/EJ = 7/12 Fb^2/EJ$$

$$L_{CD}^{xo} = \int_0^b (-x/b + 1/2 x^2/b^2) Fb 1/EJ dx + 1 (-1) 1 Fb^2/EJ$$

$$= [-1/2 x^2/b + 1/6 x^3/b^2]_0^b Fb 1/EJ + 1 (-1) 1 Fb^2/EJ$$

$$= (-1/2 b + 1/6 b) Fb 1/EJ + 1 (-1) 1 Fb^2/EJ = -4/3 Fb^2/EJ$$

$$L_{DC}^{xo} = \int_0^b (-1/2 + 1/2 x^2/b^2) Fb 1/EJ dx + 1 (-1) 1 Fb^2/EJ$$

$$= [-1/2 x + 1/6 x^3/b^2]_0^b Fb 1/EJ + 1 (-1) 1 Fb^2/EJ$$

$$= (-1/2 b + 1/6 b) Fb 1/EJ + 1 (-1) 1 Fb^2/EJ = -4/3 Fb^2/EJ$$

$$L_{DE}^{xo} = \int_0^b (-1/2 + x/b - 1/2 x^2/b^2) Fb 1/EJ dx = [-1/2 x + 1/2 x^2/b - 1/6 x^3/b^2]_0^b Fb 1/EJ$$

$$= (-1/2 b + 1/2 b - 1/6 b) Fb 1/EJ = -1/6 Fb^2/EJ$$

$$L_{ED}^{xo} = \int_0^b (-1/2 x^2/b^2) Fb 1/EJ dx = [-1/6 x^3/b^2]_0^b Fb 1/EJ$$

$$= (-1/6 b) Fb 1/EJ = -1/6 Fb^2/EJ$$

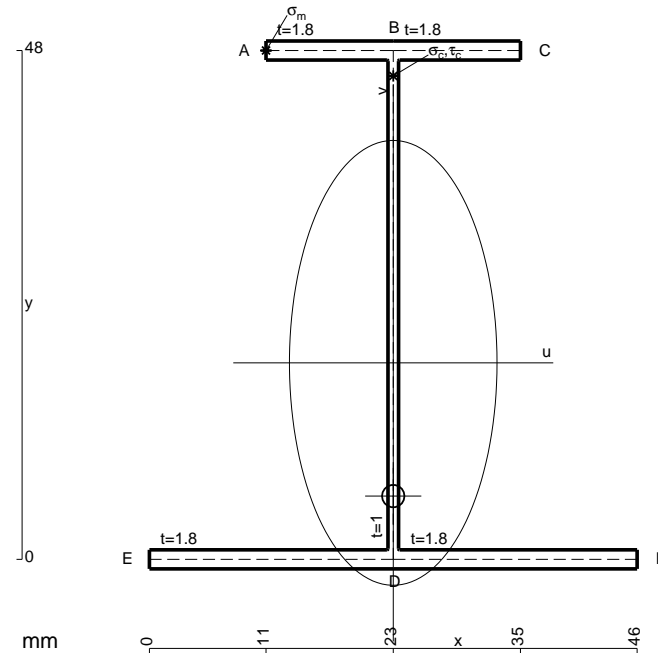

- A = 174. mm²
- J_u = 76601. mm⁴
- J_v = 16674. mm⁴
- J_t = 152.1 mm⁴
- y_o = -12.57 mm
- y_g = 18.54 mm
- T_y = -740. N
- M_x = -562400. Nmm
- x_m = 11. mm
- y_m = 48. mm
- u_m = -12. mm
- v_m = 29.46 mm
- σ_m = -Mv/J_u = 216.3 N/mm²
- x_c = 23. mm
- y_c = 48. mm
- v_c = 29.46 mm
- σ_c = -Mv/J_u = 216.3 N/mm²
- τ_c = TS'/tJ_u = 12.3 N/mm²
- τ_g = TS'/tJ_u = 12.3 N/mm²
- t_c = 370. mm
- σ_o = √σ²+3τ² = 217.4 N/mm²

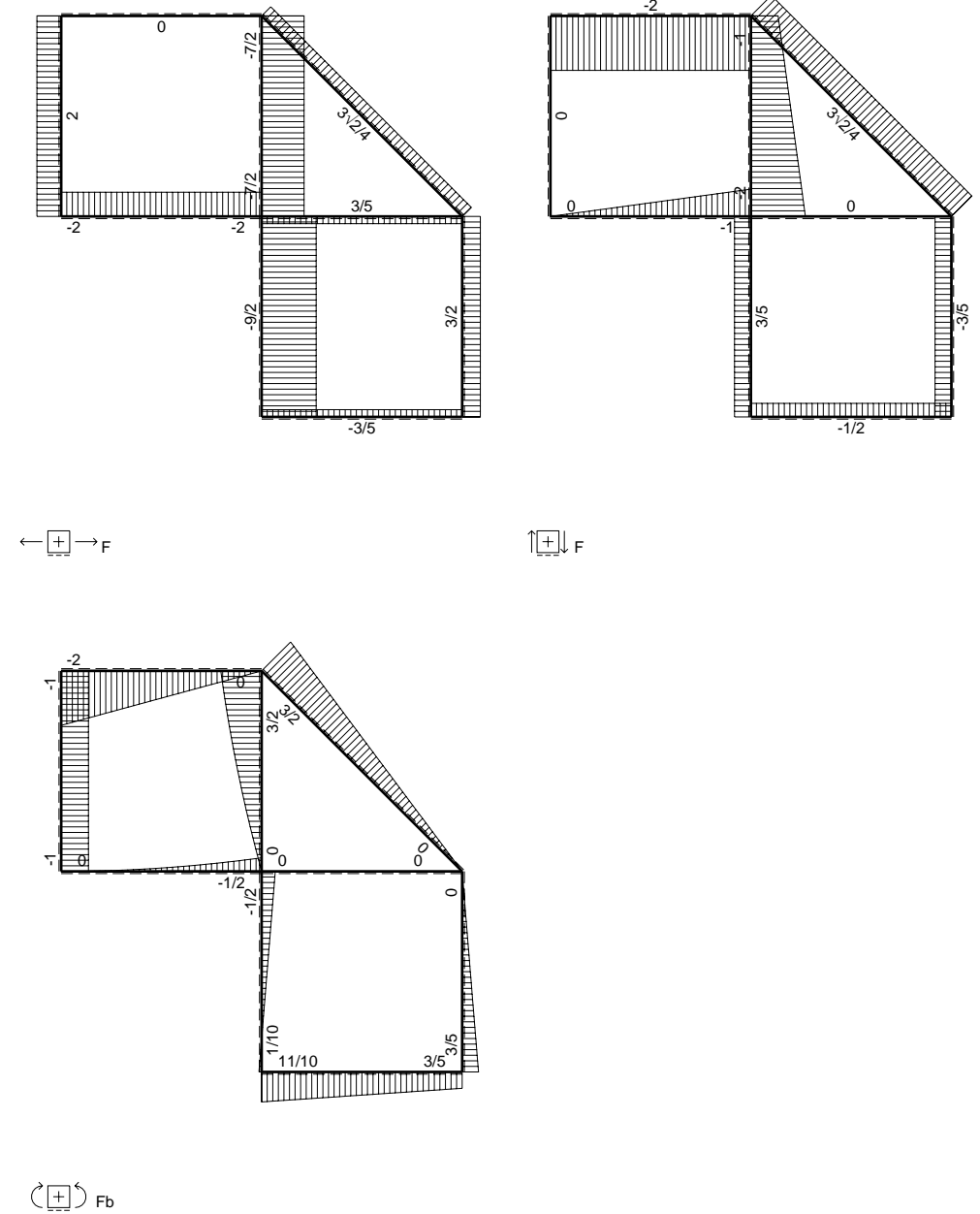
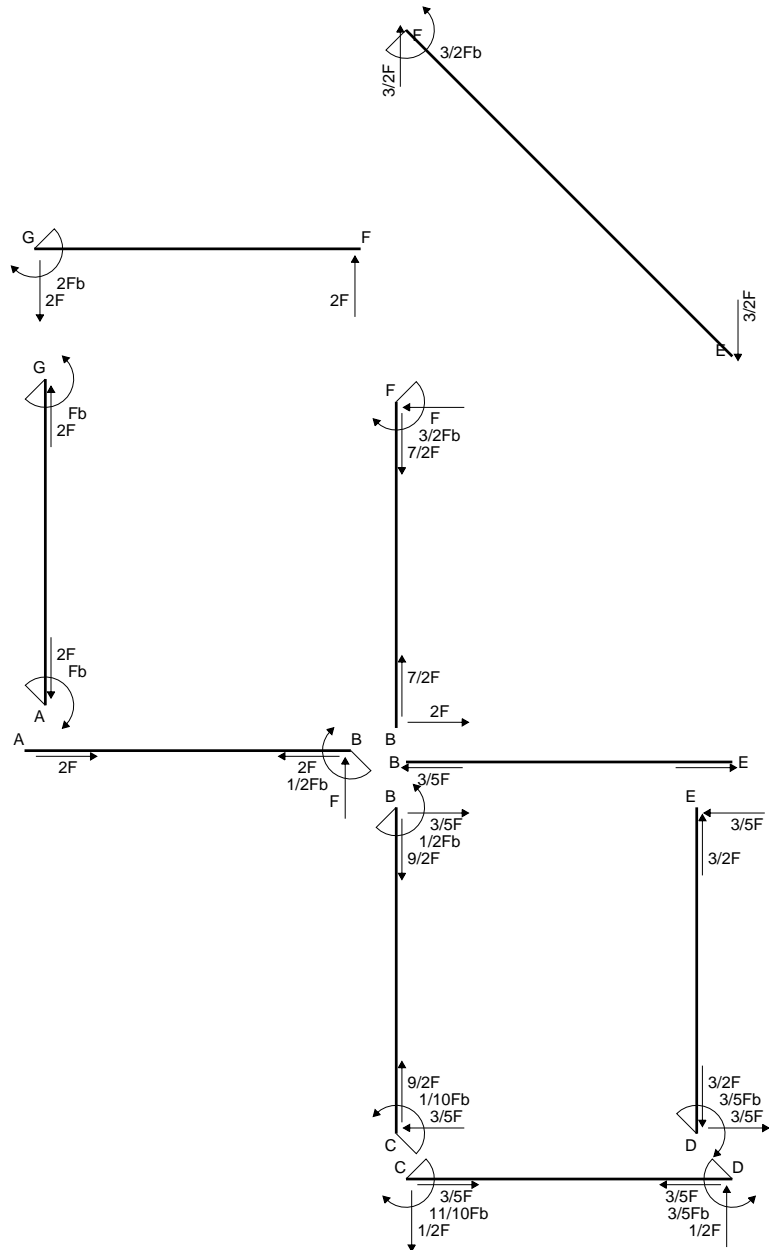

\oplus F_b

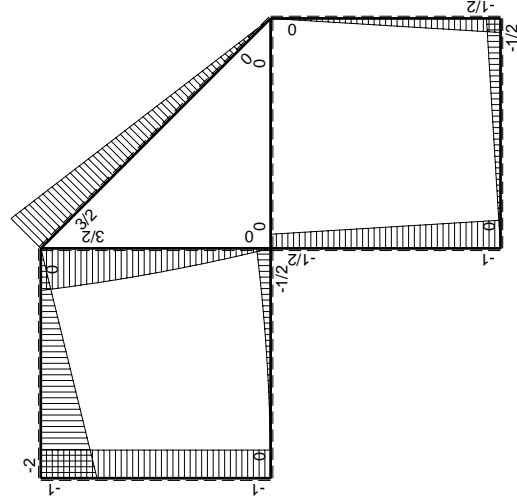
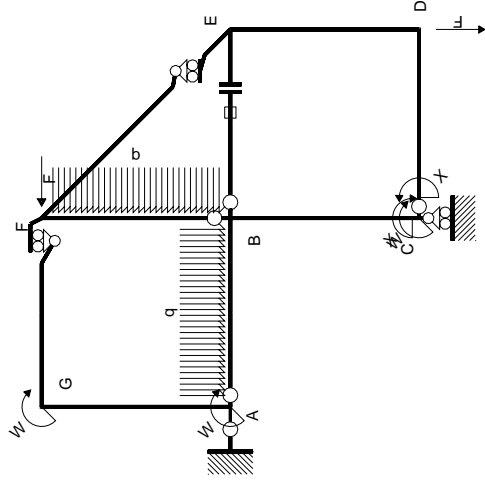

Schema di calcolo iperstatico

M_0 flessione da carichi assegnati

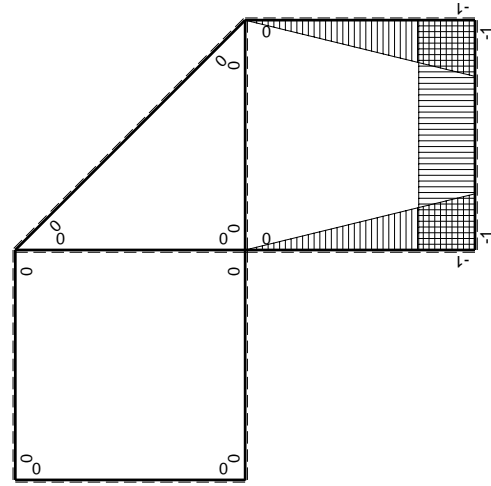

M_x flessione da iperstatica X=1

Quadro contribuiti PLV per iperstatica X=W_{cd}

→	$M_x(x)$	$M_0(x)$	$M_x M_0$	$M_x M_x$	$\int M_x M_0 / EJ dx$	$\int X M_x M_x / EJ dx$
AB b	0	$-1/2qx^2$	0	0	0	0
BA b	0	$1/2Fb-Fx+1/2qx^2$	0	0	0	0
BC b	$-x/b$	$-1/2Fb-1/2Fx$	$1/2Fx+1/2Fx^2/b$	x^2/b^2	$5/12Fb^2/EJ$	$1/3Xb/EJ$
CB b	$1-x/b$	$Fb-1/2Fx$	$Fb-3/2Fx+1/2Fx^2/b$	$1-2x/b+x^2/b^2$	$1/4Fb^2/EJ$	Xb/EJ
CD b	-1	$-1/2Fx$	$1/2Fx$	1	$1/6Fb^2/EJ$	$1/3Xb/EJ$
DC b	1	$1/2Fb-1/2Fx$	$1/2Fb-1/2Fx$	1	$1/4Fb^2/EJ$	Xb/EJ
DE b	$-1+x/b$	$-1/2Fb+1/2Fx$	$1/2Fb-Fx+1/2Fx^2/b$	$1-2x/b+x^2/b^2$	$1/6Fb^2/EJ$	$1/3Xb/EJ$
ED b	x/b	$1/2Fx$	$1/2Fx^2/b$	x^2/b^2	0	0
EF $\sqrt{2}b$	0	$3\sqrt{2}/4Fx$	0	0	0	0
FG b	0	$-2Fx$	0	0	0	0
GF b	0	$2Fb-2Fx$	0	0	0	0
GA b	0	$-Fb$	0	0	0	0
AG b	0	Fb	0	0	0	0
FB b	0	$3/2Fb-Fx-1/2qx^2$	0	0	0	0
BF b	0	$-2Fx+1/2qx^2$	0	0	0	0
BE b	0	0	0	0	0	0
EB b	0	0	0	0	0	0
BE	elongazione asta $N_{1, BE}^{\epsilon_{BE} - BE}$				Fb^2/EJ	
	totali				$11/6Fb^2/EJ$	$5/3Xb/EJ$
	iperstatica X=W _{cd}				$-11/10Fb$	

Sviluppi di calcolo iperstatica

$$L_{BC}^{xx} = \int_0^b (x^2/b^2) 1/EJ dx = [1/3 x^3/b^2]_0^b 1/EJ$$

$$= (1/3 b) 1/EJ = 1/3 b/EJ$$

$$L_{CB}^{xx} = \int_0^b (1 - 2x/b + x^2/b^2) 1/EJ dx = [x - x^2/b + 1/3 x^3/b^2]_0^b 1/EJ$$

$$= (b - b + 1/3 b) 1/EJ = 1/3 b/EJ$$

$$L_{CD}^{xx} = \int_0^b (1) 1/EJ dx = [x]_0^b 1/EJ$$

$$= (b) 1/EJ = b/EJ$$

$$L_{DC}^{xx} = \int_0^b (1) 1/EJ dx = [x]_0^b 1/EJ$$

$$= (b) 1/EJ = b/EJ$$

$$L_{DE}^{xx} = \int_0^b (1 - 2x/b + x^2/b^2) 1/EJ dx = [x - x^2/b + 1/3 x^3/b^2]_0^b 1/EJ$$

$$= (b - b + 1/3 b) 1/EJ = 1/3 b/EJ$$

$$L_{ED}^{xx} = \int_0^b (x^2/b^2) 1/EJ dx = [1/3 x^3/b^2]_0^b 1/EJ$$

$$= (1/3 b) 1/EJ = 1/3 b/EJ$$

$$L_{BC}^{xo} = \int_0^b (1/2 x/b + 1/2 x^2/b^2) Fb 1/EJ dx = [1/4 x^2/b + 1/6 x^3/b^2]_0^b Fb 1/EJ$$

$$= (1/4 b + 1/6 b) Fb 1/EJ = 5/12 Fb^2/EJ$$

$$L_{CB}^{xo} = \int_0^b (1 - 3/2 x/b + 1/2 x^2/b^2) Fb 1/EJ dx = [x - 3/4 x^2/b + 1/6 x^3/b^2]_0^b Fb 1/EJ$$

$$= (b - 3/4 b + 1/6 b) Fb 1/EJ = 5/12 Fb^2/EJ$$

$$L_{CD}^{xo} = \int_0^b (1/2 x/b) Fb 1/EJ dx = [1/4 x^2/b]_0^b Fb 1/EJ$$

$$= (1/4 b) Fb 1/EJ = 1/4 Fb^2/EJ$$

$$L_{DC}^{xo} = \int_0^b (1/2 - 1/2 x/b) Fb 1/EJ dx = [1/2 x - 1/4 x^2/b]_0^b Fb 1/EJ$$

$$= (1/2 b - 1/4 b) Fb 1/EJ = 1/4 Fb^2/EJ$$

$$L_{DE}^{xo} = \int_0^b (1/2 - x/b + 1/2 x^2/b^2) Fb 1/EJ dx = [1/2 x - 1/2 x^2/b + 1/6 x^3/b^2]_0^b Fb 1/EJ$$

$$= (1/2 b - 1/2 b + 1/6 b) Fb 1/EJ = 1/6 Fb^2/EJ$$

$$L_{ED}^{xo} = \int_0^b (1/2 x^2/b^2) Fb 1/EJ dx = [1/6 x^3/b^2]_0^b Fb 1/EJ$$

$$= (1/6 b) Fb 1/EJ = 1/6 Fb^2/EJ$$

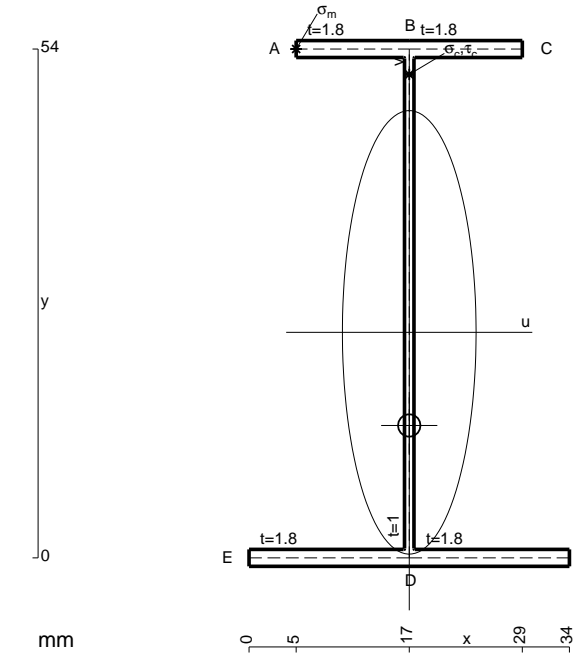

- A = 158.4 mm²
- J_u = 87739. mm⁴
- J_v = 7969. mm⁴
- J_i = 130.8 mm⁴
- y_o = -9.881 mm
- y_g = 23.93 mm
- T_y = -720. N
- M_x = -655200. Nmm
- x_m = 5. mm
- y_m = 54. mm
- u_m = -12. mm
- v_m = 30.07 mm
- σ_m = -M_y/J_u = 224.5 N/mm²
- x_c = 17. mm
- y_c = 54. mm
- v_c = 30.07 mm
- σ_c = -M_y/J_u = 224.5 N/mm²
- τ_c = T_S/t_{J_u} = 10.66 N/mm²
- τ_g = T_S/t_{J_u} = 10.66 N/mm²
- t_c = 360. mm
- σ_o = √σ²+3τ² = 225.3 N/mm²

