

$V_{FG} = -F$	$k_{AB} = 4EJ/b$	$EJ_{FG} = EJ$
$V_{CB} = -F$	$EJ_{AB} = EJ$	$EJ_{GC} = EJ$
$q_{AB} = -q = -F/b$	$EJ_{BC} = EJ$	$EJ_{HG} = EJ$
$p_{HB} = -q = -F/b$	$EJ_{AD} = EJ$	$EJ_{HB} = EJ$
$q_{HG} = -q = -F/b$	$EJ_{DE} = EJ$	$EJ_{HE} = EJ$
$\theta_{BC} = -\theta = -\alpha T/b = -bF/EJ$	$EJ_{EF} = EJ$	

Reazioni iperstatiche in soluzione: $X=W_{DA}$
 Carichi e deformazioni date hanno verso efficace in disegno.
 Calcolare reazioni vincolari della struttura e delle aste.
 Tracciare i diagrammi quotati delle azioni interne nelle aste.
 $J_{YZ} - x_{YZ} - \theta_{YZ}$ riferimento locale asta YZ con origine in Y.
 Curvatura θ asta BC positiva se convessa a destra con inizio B.
 © Adolfo Zavelani Rossi, Politecnico di Milano, vers.27.03.13

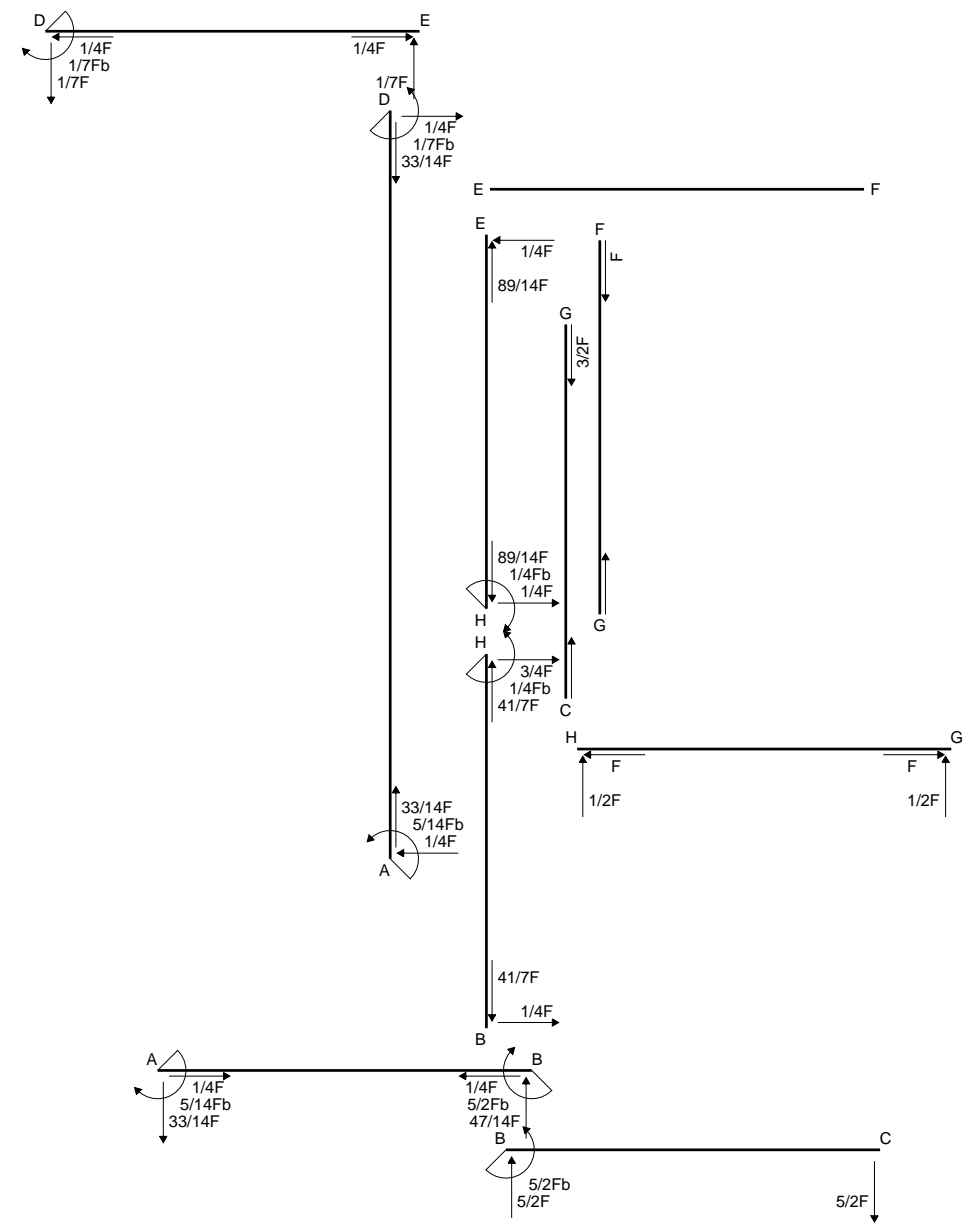

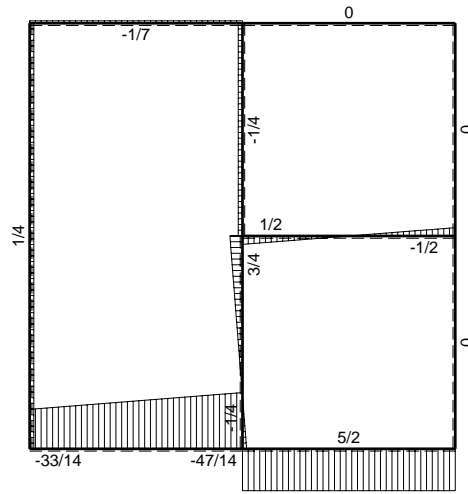
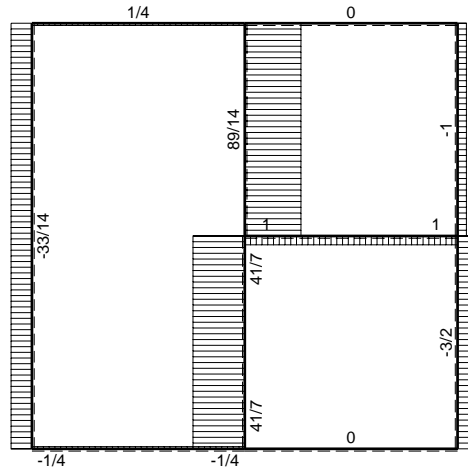

← ⊕ → F

↑ ⊕ ↓ F

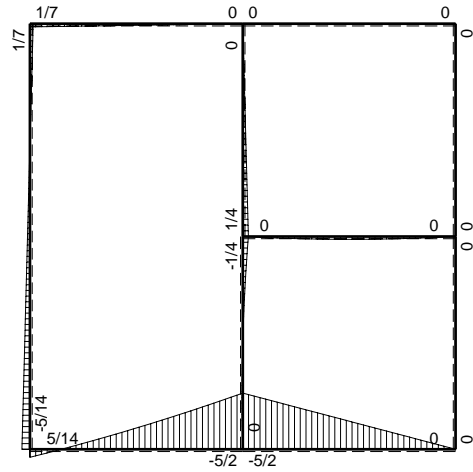

⊕ F_b

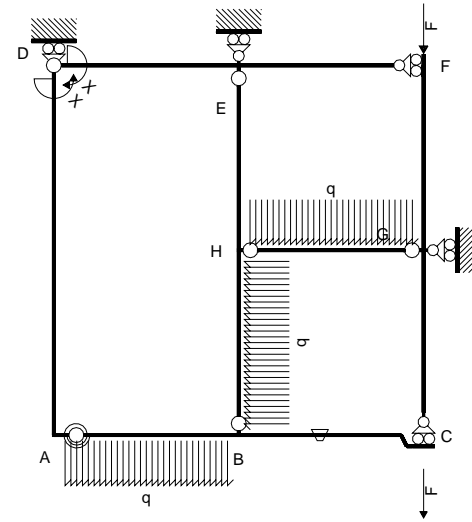

Schema di calcolo iperstatico

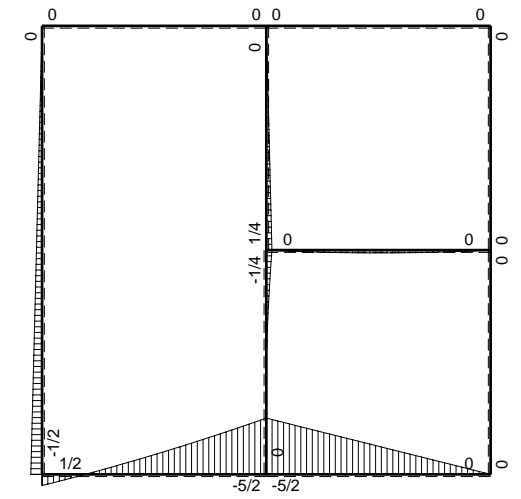

⊕ M₀ flessione da carichi assegnati

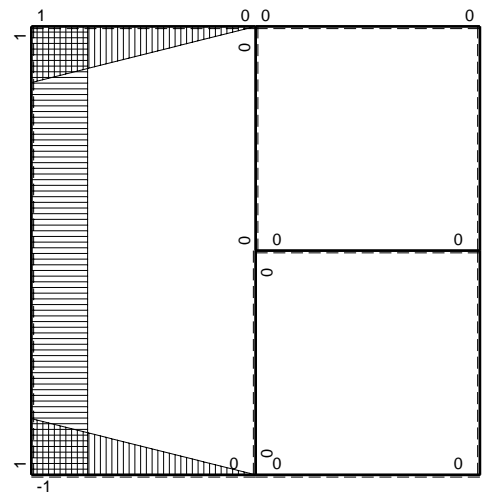

⊕ M_x flessione da iperstatica X=1

Quadro contributi PLV per iperstatica $X=W_{DA}$

→	$M_x(x)$	$M_o(x)$	θ	$M_x M_o$	$M_x \theta$	$M_x M_x$	$\int M_x(M_o/EJ+\theta)dx$	$\int X M_x M_x/EJ dx$	
AB b	$-1+x/b$	$1/2Fb-5/2Fx-1/2qx^2$	0	$-1/2Fb+3Fx-2Fx^2/b-1/2qx^3/b$	0	$1-2x/b+x^2/b^2$	$(5/24+0)Fb^2/EJ$	$1/3Xb/EJ$	
BA b	x/b	$5/2Fb-7/2Fx+1/2qx^2$	0	$5/2Fx-7/2Fx^2/b+1/2qx^3/b$	0	x^2/b^2			
BC b	0	$-5/2Fb+5/2Fx$	$-Fb/EJ$	0	0	0	0+0	0	
CB b	0	$5/2Fx$	Fb/EJ	0	0	0			
AD 2b	1	$-1/2Fb+1/4Fx$	0	$-1/2Fb+1/4Fx$	0	1	$(-1/2+0)Fb^2/EJ$	$2Xb/EJ$	
DA 2b	-1	$1/4Fx$	0	$-1/4Fx$	0	1			
DE b	$1-x/b$	0	0	0	0	$1-2x/b+x^2/b^2$	0+0	$1/3Xb/EJ$	
ED b	$-x/b$	0	0	0	0	x^2/b^2			
EF b	0	0	0	0	0	0	0+0	0	
FE b	0	0	0	0	0	0			
FG b	0	0	0	0	0	0	0+0	0	
GF b	0	0	0	0	0	0			
GC b	0	0	0	0	0	0	0+0	0	
CG b	0	0	0	0	0	0			
HG b	0	$1/2Fx-1/2qx^2$	0	0	0	0	0+0	0	
GH b	0	$-1/2Fx+1/2qx^2$	0	0	0	0			
HB b	0	$-1/4Fb+3/4Fx-1/2qx^2$	0	0	0	0	0+0	0	
BH b	0	$-1/4Fx+1/2qx^2$	0	0	0	0			
HE b	0	$1/4Fb-1/4Fx$	0	0	0	0	0+0	0	
EH b	0	$-1/4Fx$	0	0	0	0			
AB	molla asta $-W_{1AB}(W_{0AB}+XW_{1AB})/k_{AB}$							$-1/8Fb^2/EJ$	$1/4Xb/EJ$
	totali							$-5/12Fb^2/EJ$	$35/12Xb/EJ$
	iperstatica $X=W_{DA}$							$1/7Fb$	

Sviluppi di calcolo iperstatica

$$L_{AB}^{xx} = \int_0^b (1 - 2x/b + x^2/b^2) \cdot 1/EJ \, dx + 1 \cdot 1/4 \cdot b/EJ = \left[x - x^2/b + 1/3 x^3/b^2 \right]_0^b \cdot 1/EJ + 1 \cdot 1/4 \cdot b/EJ$$

$$= (b - b + 1/3 b) \cdot 1/EJ + 1 \cdot 1/4 \cdot b/EJ = 7/12 \cdot b/EJ$$

$$L_{BA}^{xx} = \int_0^b (x^2/b^2) \cdot 1/EJ \, dx + 1 \cdot 1/4 \cdot b/EJ = \left[1/3 x^3/b^2 \right]_0^b \cdot 1/EJ + 1 \cdot 1/4 \cdot b/EJ$$

$$= (1/3 b) \cdot 1/EJ + 1 \cdot 1/4 \cdot b/EJ = 7/12 \cdot b/EJ$$

$$L_{AD}^{xx} = \int_0^{2b} (1) \cdot 1/EJ \, dx = \left[x \right]_0^{2b} \cdot 1/EJ$$

$$= (2b) \cdot 1/EJ = 2 \cdot b/EJ$$

$$L_{DA}^{xx} = \int_0^{2b} (1) \cdot 1/EJ \, dx = \left[x \right]_0^{2b} \cdot 1/EJ$$

$$= (2b) \cdot 1/EJ = 2 \cdot b/EJ$$

$$L_{DE}^{xx} = \int_0^b (1 - 2x/b + x^2/b^2) \cdot 1/EJ \, dx = \left[x - x^2/b + 1/3 x^3/b^2 \right]_0^b \cdot 1/EJ$$

$$= (b - b + 1/3 b) \cdot 1/EJ = 1/3 \cdot b/EJ$$

$$L_{ED}^{xx} = \int_0^b (x^2/b^2) \cdot 1/EJ \, dx = \left[1/3 x^3/b^2 \right]_0^b \cdot 1/EJ$$

$$= (1/3 b) \cdot 1/EJ = 1/3 \cdot b/EJ$$

$$L_{AB}^{xo} = \int_0^b (-1/2 + 3x/b - 2x^2/b^2 - 1/2 x^3/b^3) \cdot Fb \cdot 1/EJ \, dx + 1 \cdot (-1/2) \cdot 1/4 \cdot Fb^2/EJ$$

$$= \left[-1/2 x + 3/2 x^2/b - 2/3 x^3/b^2 - 1/8 x^4/b^3 \right]_0^b \cdot Fb \cdot 1/EJ + 1 \cdot (-1/2) \cdot 1/4 \cdot Fb^2/EJ$$

$$= (-1/2 b + 3/2 b - 2/3 b - 1/8 b) \cdot Fb \cdot 1/EJ + 1 \cdot (-1/2) \cdot 1/4 \cdot Fb^2/EJ = 1/12 \cdot Fb^2/EJ$$

$$L_{BA}^{xo} = \int_0^b (5/2 x/b - 7/2 x^2/b^2 + 1/2 x^3/b^3) \cdot Fb \cdot 1/EJ \, dx + 1 \cdot (-1/2) \cdot 1/4 \cdot Fb^2/EJ$$

$$= \left[5/4 x^2/b - 7/6 x^3/b^2 + 1/8 x^4/b^3 \right]_0^b \cdot Fb \cdot 1/EJ + 1 \cdot (-1/2) \cdot 1/4 \cdot Fb^2/EJ$$

$$= (5/4 b - 7/6 b + 1/8 b) \cdot Fb \cdot 1/EJ + 1 \cdot (-1/2) \cdot 1/4 \cdot Fb^2/EJ = 1/12 \cdot Fb^2/EJ$$

$$L_{AD}^{xo} = \int_0^{2b} (-1/2 + 1/4 x/b) \cdot Fb \cdot 1/EJ \, dx = \left[-1/2 x + 1/8 x^2/b \right]_0^{2b} \cdot Fb \cdot 1/EJ$$

$$= (-b + 1/2 b) \cdot Fb \cdot 1/EJ = -1/2 \cdot Fb^2/EJ$$

$$L_{DA}^{xo} = \int_0^{2b} (-1/4 x/b) \cdot Fb \cdot 1/EJ \, dx = \left[-1/8 x^2/b \right]_0^{2b} \cdot Fb \cdot 1/EJ$$

$$= (-1/2 b) \cdot Fb \cdot 1/EJ = -1/2 \cdot Fb^2/EJ$$

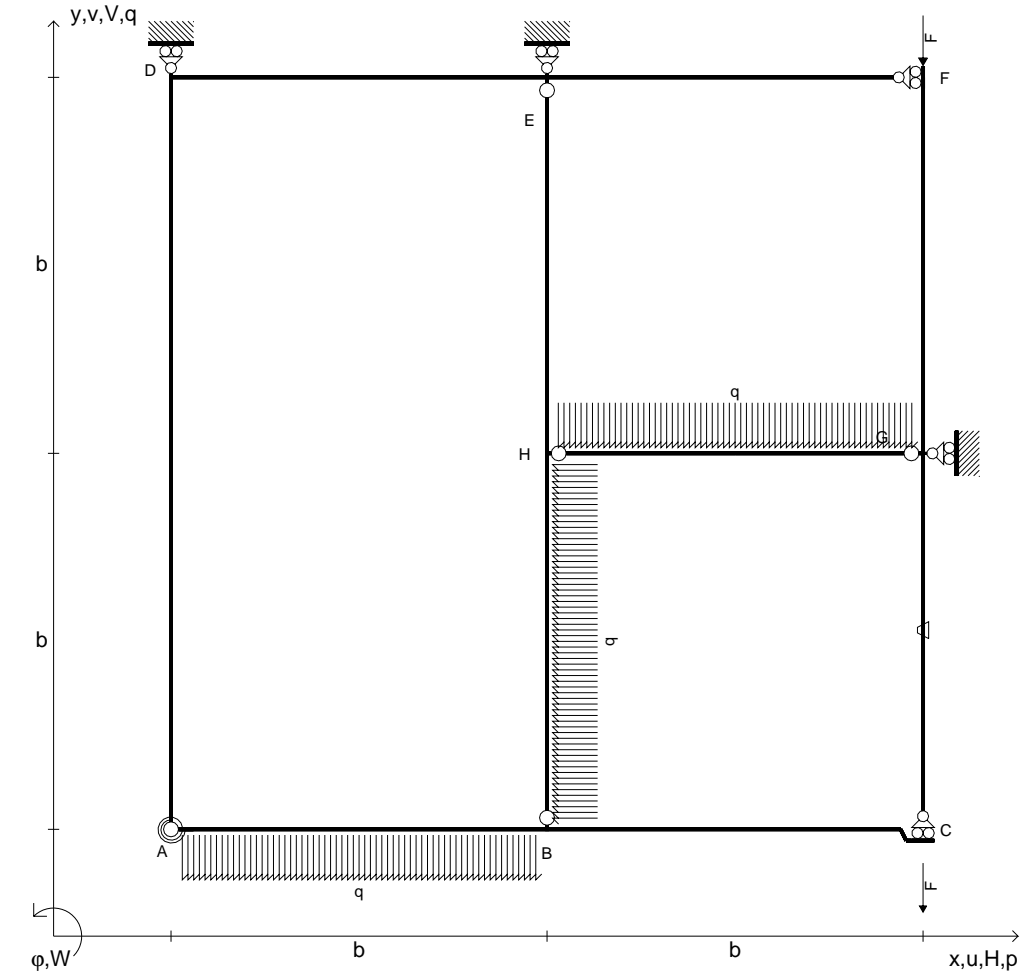

$V_{FG} = -F$	$k_{AB} = 4EJ/b$	$EJ_{FG} = EJ$
$V_{CB} = -F$	$EJ_{AB} = EJ$	$EJ_{GC} = EJ$
$q_{AB} = -q = -F/b$	$EJ_{BC} = EJ$	$EJ_{HG} = EJ$
$p_{HB} = -q = -F/b$	$EJ_{AD} = EJ$	$EJ_{HB} = EJ$
$q_{HG} = -q = -F/b$	$EJ_{DE} = EJ$	$EJ_{HE} = EJ$
$\theta_{GC} = -\theta = -\alpha T/b = -bF/EJ$	$EJ_{EF} = EJ$	

Reazioni iperstatiche in soluzione: $X=W_{AB}$
 Carichi e deformazioni date hanno verso efficace in disegno.
 Calcolare reazioni vincolari della struttura e delle aste.
 Tracciare i diagrammi quotati delle azioni interne nelle aste.
 $J_{YZ} - x_{YZ} - \theta_{YZ}$ riferimento locale asta YZ con origine in Y.
 Curvatura θ asta GC positiva se convessa a destra con inizio G.
 © Adolfo Zavelani Rossi, Politecnico di Milano, vers.27.03.13

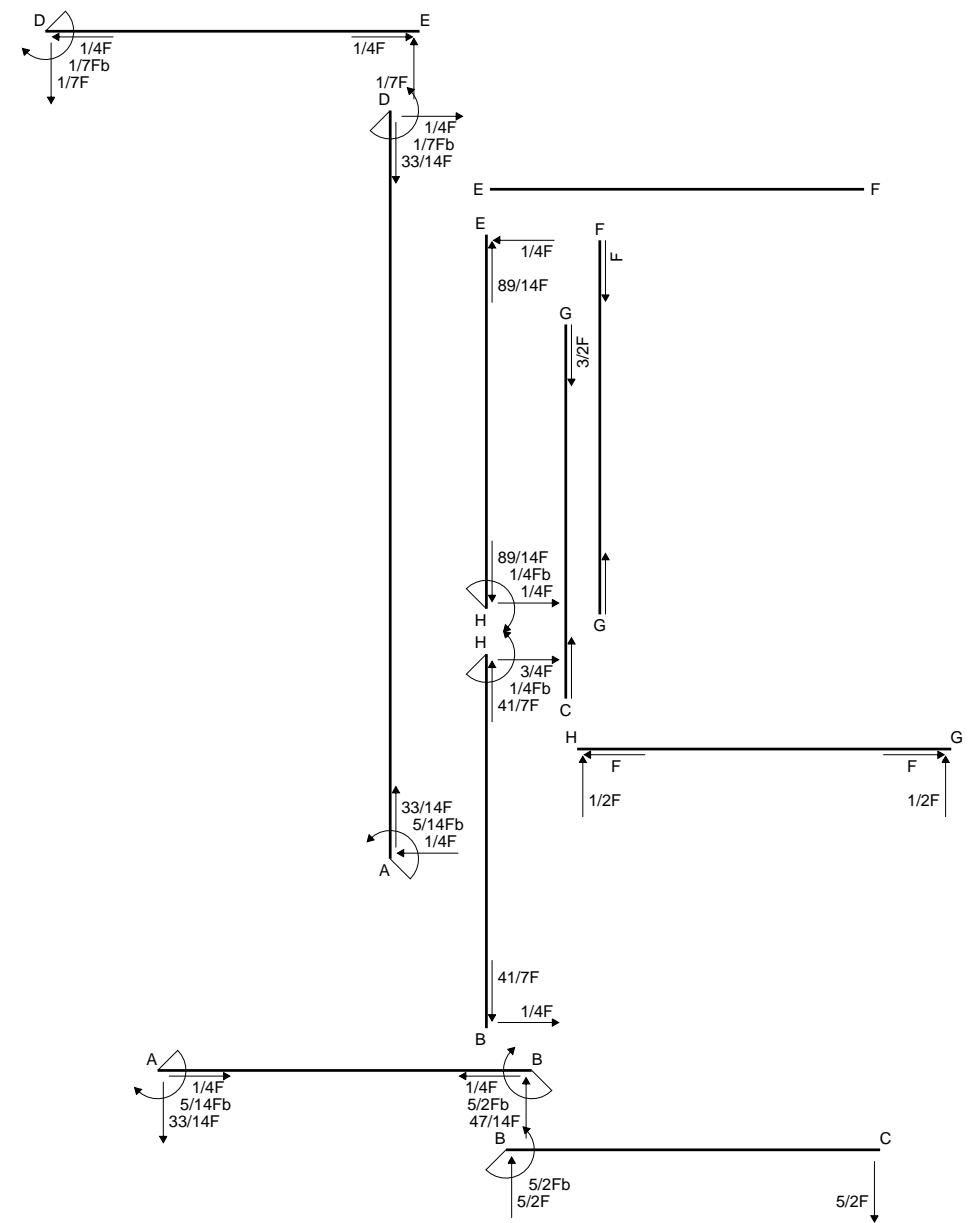

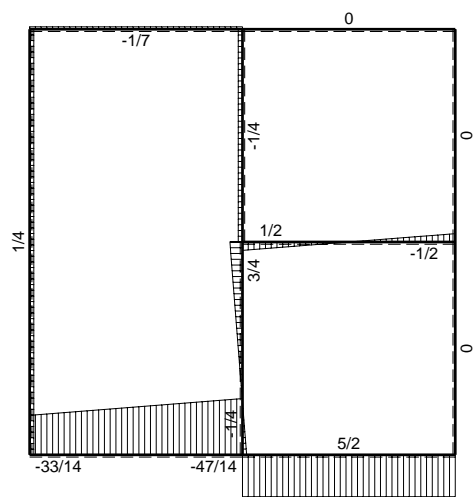
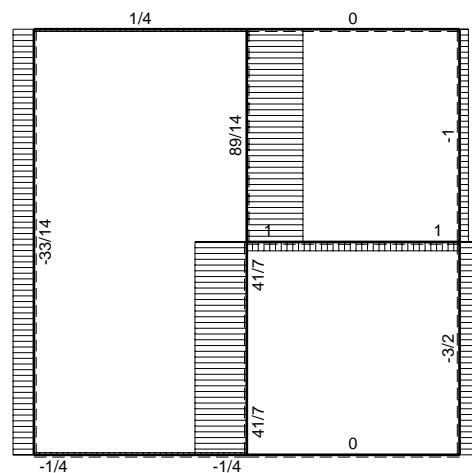

← ⊕ → F

↑ ⊕ ↓ F

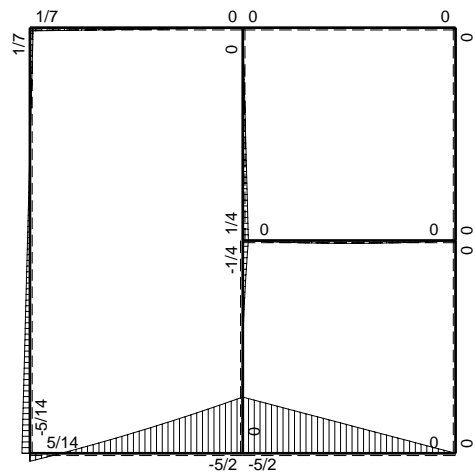

⊕ F_b

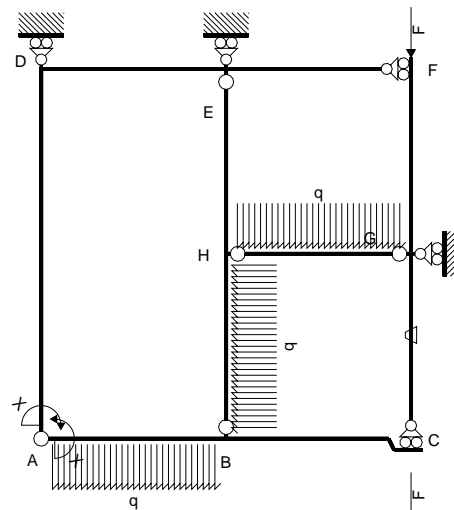

Schema di calcolo iperstatico

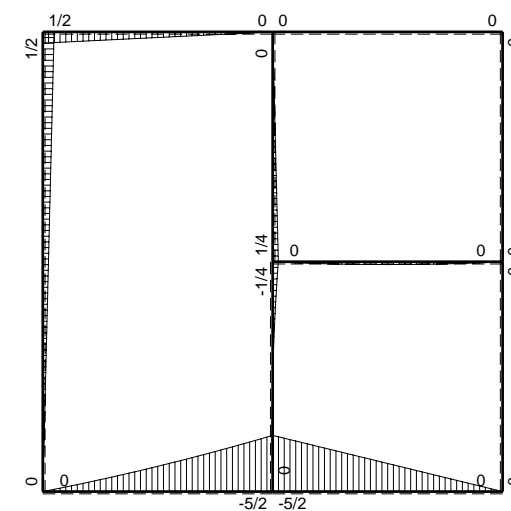

⊕ M₀ flessione da carichi assegnati

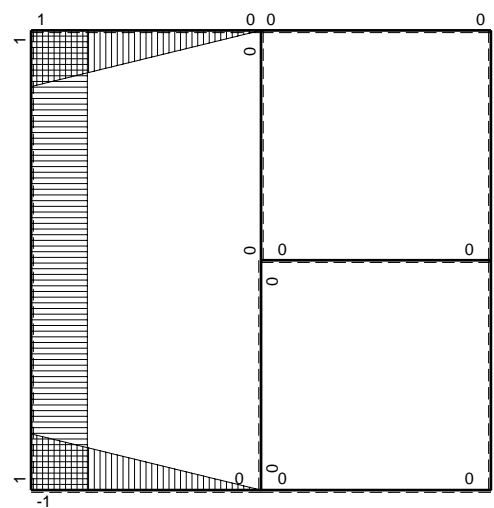

⊕ M_x flessione da iperstatica X=1

Quadro contributi PLV per iperstatica $X=W_{AB}$

→	$M_x(x)$	$M_o(x)$	θ	$M_x M_o$	$M_x \theta$	$M_x M_x$	$\int M_x(M_o/EJ+\theta)dx$	$\int X M_x M_x/EJ dx$
AB b	$-1+x/b$	$-2Fx-1/2qx^2$	0	$2Fx-3/2Fx^2/b-1/2qx^3/b$	0	$1-2x/b+x^2/b^2$	$(3/8+0)Fb^2/EJ$	$1/3Xb/EJ$
BA b	x/b	$5/2Fb-3Fx+1/2qx^2$	0	$5/2Fx-3Fx^2/b+1/2qx^3/b$	0	x^2/b^2		
BC b	0	$-5/2Fb+5/2Fx$	0	0	0	0	0+0	0
CB b	0	$5/2Fx$	0	0	0	0		
AD 2b	1	$1/4Fx$	0	$1/4Fx$	0	1	$(1/2+0)Fb^2/EJ$	$2Xb/EJ$
DA 2b	-1	$-1/2Fb+1/4Fx$	0	$1/2Fb-1/4Fx$	0	1		
DE b	$1-x/b$	$1/2Fb-1/2Fx$	0	$1/2Fb-Fx+1/2Fx^2/b$	0	$1-2x/b+x^2/b^2$	$(1/6+0)Fb^2/EJ$	$1/3Xb/EJ$
ED b	$-x/b$	$-1/2Fx$	0	$1/2Fx^2/b$	0	x^2/b^2		
EF b	0	0	0	0	0	0	0+0	0
FE b	0	0	0	0	0	0		
FG b	0	0	0	0	0	0	0+0	0
GF b	0	0	0	0	0	0		
GC b	0	0	$-Fb/EJ$	0	0	0	0+0	0
CG b	0	0	Fb/EJ	0	0	0		
HG b	0	$1/2Fx-1/2qx^2$	0	0	0	0	0+0	0
GH b	0	$-1/2Fx+1/2qx^2$	0	0	0	0		
HB b	0	$-1/4Fb+3/4Fx-1/2qx^2$	0	0	0	0	0+0	0
BH b	0	$-1/4Fx+1/2qx^2$	0	0	0	0		
HE b	0	$1/4Fb-1/4Fx$	0	0	0	0	0+0	0
EH b	0	$-1/4Fx$	0	0	0	0		
AB	molla asta $-W_{1AB}(W_{0AB}+XW_{1AB})/k_{AB}$							$1/4Xb/EJ$
	totali						$25/24Fb^2/EJ$	$35/12Xb/EJ$
	iperstatica $X=W_{AB}$						$-5/14Fb$	

Sviluppi di calcolo iperstatica

$$L_{AB}^{xx} = \int_0^b (1 - 2x/b + x^2/b^2) \cdot 1/EJ \, dx + 1 \cdot 1/4 \cdot b/EJ = \left[x - x^2/b + 1/3 x^3/b^2 \right]_0^b \cdot 1/EJ + 1 \cdot 1/4 \cdot b/EJ$$

$$= (b - b + 1/3 b) \cdot 1/EJ + 1 \cdot 1/4 \cdot b/EJ = 7/12 \cdot b/EJ$$

$$L_{BA}^{xx} = \int_0^b (x^2/b^2) \cdot 1/EJ \, dx + 1 \cdot 1/4 \cdot b/EJ = \left[1/3 x^3/b^2 \right]_0^b \cdot 1/EJ + 1 \cdot 1/4 \cdot b/EJ$$

$$= (1/3 b) \cdot 1/EJ + 1 \cdot 1/4 \cdot b/EJ = 7/12 \cdot b/EJ$$

$$L_{AD}^{xx} = \int_0^{2b} (1) \cdot 1/EJ \, dx = \left[x \right]_0^{2b} \cdot 1/EJ$$

$$= (2b) \cdot 1/EJ = 2 \cdot b/EJ$$

$$L_{DA}^{xx} = \int_0^{2b} (1) \cdot 1/EJ \, dx = \left[x \right]_0^{2b} \cdot 1/EJ$$

$$= (2b) \cdot 1/EJ = 2 \cdot b/EJ$$

$$L_{DE}^{xx} = \int_0^b (1 - 2x/b + x^2/b^2) \cdot 1/EJ \, dx = \left[x - x^2/b + 1/3 x^3/b^2 \right]_0^b \cdot 1/EJ$$

$$= (b - b + 1/3 b) \cdot 1/EJ = 1/3 \cdot b/EJ$$

$$L_{ED}^{xx} = \int_0^b (x^2/b^2) \cdot 1/EJ \, dx = \left[1/3 x^3/b^2 \right]_0^b \cdot 1/EJ$$

$$= (1/3 b) \cdot 1/EJ = 1/3 \cdot b/EJ$$

$$L_{AB}^{xo} = \int_0^b (2x/b - 3/2 x^2/b^2 - 1/2 x^3/b^3) \cdot Fb \cdot 1/EJ \, dx + 1 \cdot 0 \cdot 1/4 \cdot Fb^2/EJ$$

$$= \left[x^2/b - 1/2 x^3/b^2 - 1/8 x^4/b^3 \right]_0^b \cdot Fb \cdot 1/EJ + 1 \cdot 0 \cdot 1/4 \cdot Fb^2/EJ$$

$$= (b - 1/2 b - 1/8 b) \cdot Fb \cdot 1/EJ + 1 \cdot 0 \cdot 1/4 \cdot Fb^2/EJ = 3/8 \cdot Fb^2/EJ$$

$$L_{BA}^{xo} = \int_0^b (5/2 x/b - 3 x^2/b^2 + 1/2 x^3/b^3) \cdot Fb \cdot 1/EJ \, dx + 1 \cdot 0 \cdot 1/4 \cdot Fb^2/EJ$$

$$= \left[5/4 x^2/b - x^3/b^2 + 1/8 x^4/b^3 \right]_0^b \cdot Fb \cdot 1/EJ + 1 \cdot 0 \cdot 1/4 \cdot Fb^2/EJ$$

$$= (5/4 b - b + 1/8 b) \cdot Fb \cdot 1/EJ + 1 \cdot 0 \cdot 1/4 \cdot Fb^2/EJ = 3/8 \cdot Fb^2/EJ$$

$$L_{AD}^{xo} = \int_0^{2b} (1/4 x/b) \cdot Fb \cdot 1/EJ \, dx = \left[1/8 x^2/b \right]_0^{2b} \cdot Fb \cdot 1/EJ$$

$$= (1/2 b) \cdot Fb \cdot 1/EJ = 1/2 \cdot Fb^2/EJ$$

$$L_{DA}^{xo} = \int_0^{2b} (1/2 - 1/4 x/b) \cdot Fb \cdot 1/EJ \, dx = \left[1/2 x - 1/8 x^2/b \right]_0^{2b} \cdot Fb \cdot 1/EJ$$

$$= (b - 1/2 b) \cdot Fb \cdot 1/EJ = 1/2 \cdot Fb^2/EJ$$

$$L_{DE}^{xo} = \int_0^b (1/2 - x/b + 1/2 x^2/b^2) \cdot Fb \cdot 1/EJ \, dx = \left[1/2 x - 1/2 x^2/b + 1/6 x^3/b^2 \right]_0^b \cdot Fb \cdot 1/EJ$$

$$= (1/2 b - 1/2 b + 1/6 b) \cdot Fb \cdot 1/EJ = 1/6 \cdot Fb^2/EJ$$

$$L_{ED}^{xo} = \int_0^b (1/2 x^2/b^2) \cdot Fb \cdot 1/EJ \, dx = \left[1/6 x^3/b^2 \right]_0^b \cdot Fb \cdot 1/EJ$$

$$= (1/6 b) \cdot Fb \cdot 1/EJ = 1/6 \cdot Fb^2/EJ$$

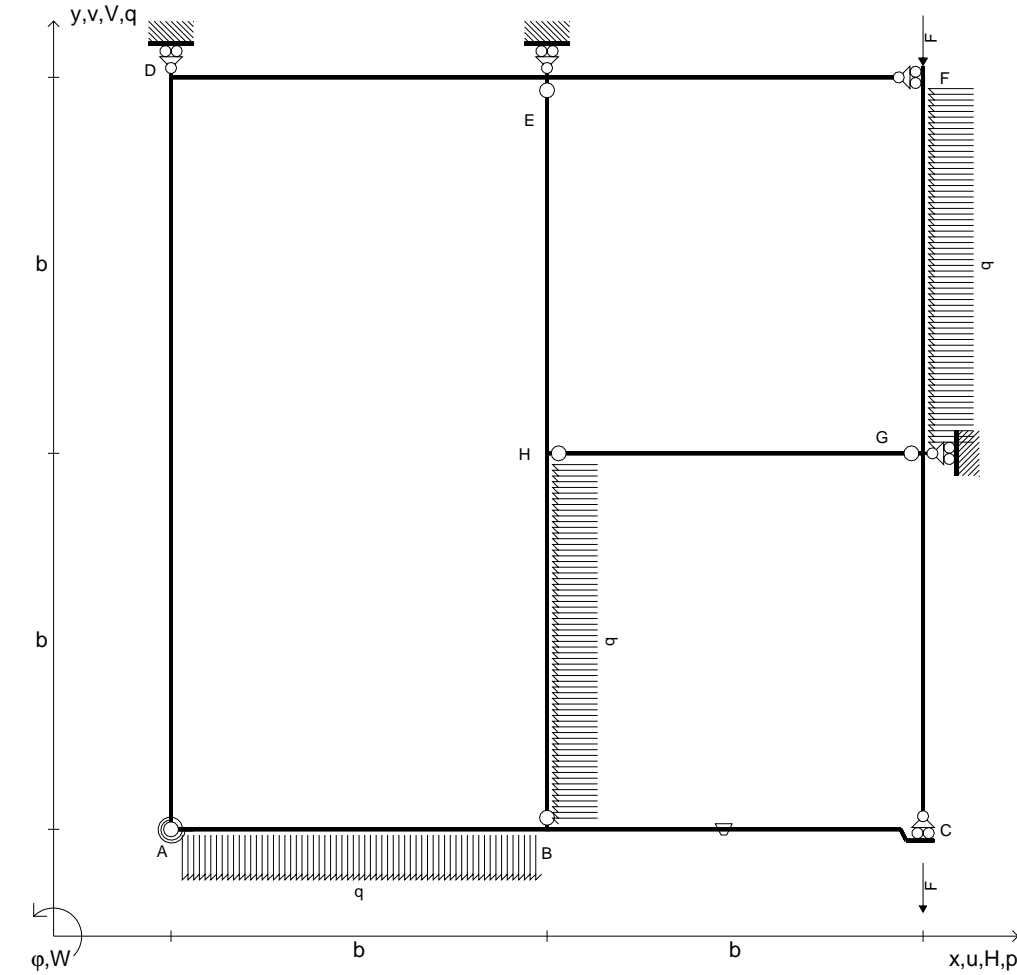

$V_{FG} = -F$	$k_{AB} = 4EJ/b$	$EJ_{FG} = EJ$
$V_{CB} = -F$	$EJ_{AB} = EJ$	$EJ_{GC} = EJ$
$q_{AB} = -q = -F/b$	$EJ_{BC} = EJ$	$EJ_{HG} = EJ$
$p_{HB} = -q = -F/b$	$EJ_{AD} = EJ$	$EJ_{HB} = EJ$
$p_{FG} = -q = -F/b$	$EJ_{DE} = EJ$	$EJ_{HE} = EJ$
$\theta_{BC} = -\theta = -\alpha T/b = -bF/EJ$	$EJ_{EF} = EJ$	

Reazioni iperstatiche in soluzione: $X=W_{AB}$

Carichi e deformazioni date hanno verso efficace in disegno.

Calcolare reazioni vincolari della struttura e delle aste.

Tracciare i diagrammi quotati delle azioni interne nelle aste.

$J_{YZ} - x_{YZ} - \theta_{YZ}$ riferimento locale asta YZ con origine in Y.

Curvatura θ asta BC positiva se convessa a destra con inizio B.

@ Adolfo Zavelani Rossi, Politecnico di Milano, vers.27.03.13

08.01.25

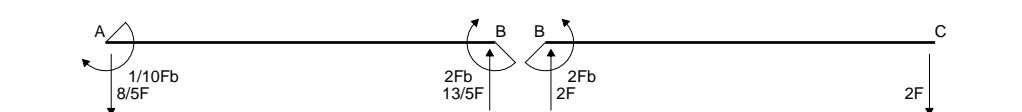
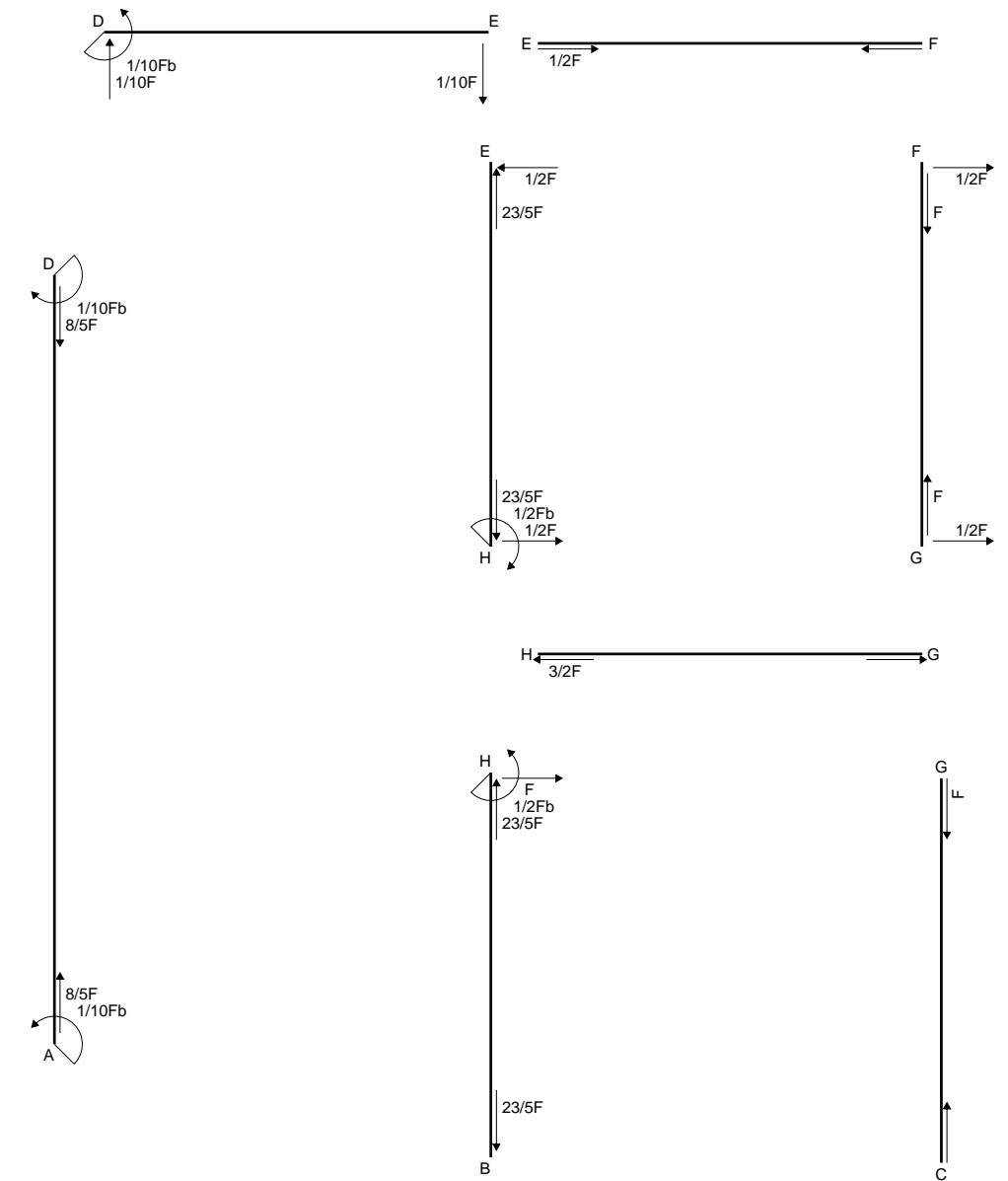

@ Adolfo Zavelani Rossi, Politecnico di Milano, vers.27.03.13

08.01.25

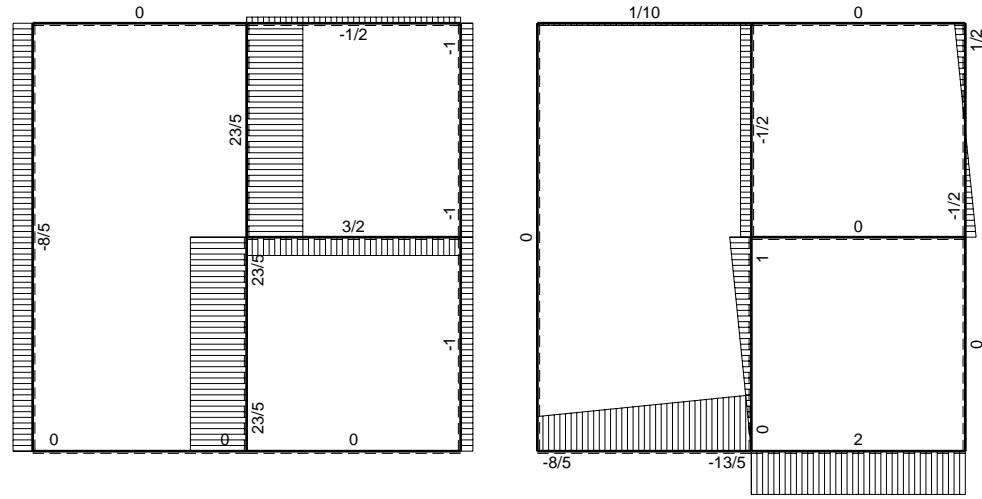

← (+) → F

↑ (+) ↓ F

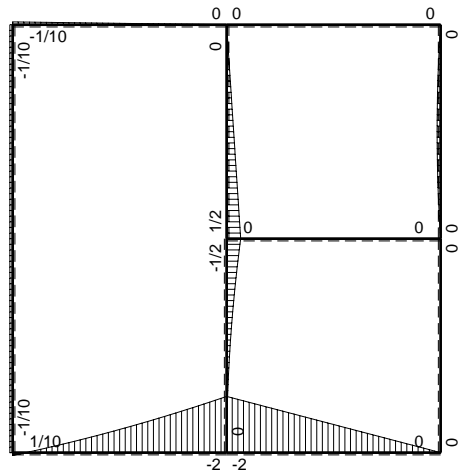

⌚ (+) ⌚ F_b

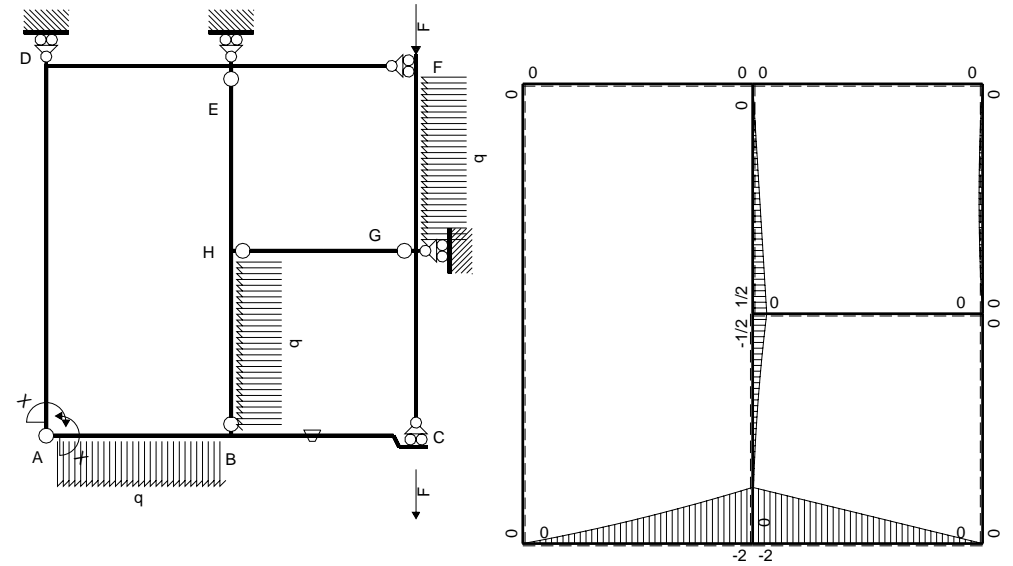

Schema di calcolo iperstatico

⌚ (+) ⌚ M_o flessione da carichi assegnati

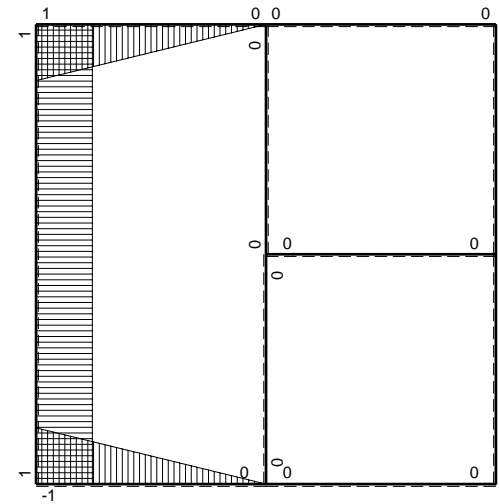

⌚ (+) ⌚ M_x flessione da iperstatica X=1

Quadro contributi PLV per iperstatica $X=W_{AB}$

→	$M_x(x)$	$M_o(x)$	θ	$M_x M_o$	$M_x \theta$	$M_x M_x$	$\int M_x(M_o/EJ+\theta)dx$	$\int X M_x M_x/EJ dx$	
AB b	$-1+x/b$	$-3/2Fx-1/2qx^2$	0	$3/2Fx-Fx^2/b-1/2qx^3/b$	0	$1-2x/b+x^2/b^2$	$(7/24+0)Fb^2/EJ$	$1/3Xb/EJ$	
BA b	x/b	$2Fb-5/2Fx+1/2qx^2$	0	$2Fx-5/2Fx^2/b+1/2qx^3/b$	0	x^2/b^2			
BC b	0	$-2Fb+2Fx$	$-Fb/EJ$	0	0	0	0+0	0	
CB b	0	$2Fx$	Fb/EJ	0	0	0			
AD 2b	1	0	0	0	0	1	0+0	$2Xb/EJ$	
DA 2b	-1	0	0	0	0	1			
DE b	$1-x/b$	0	0	0	0	$1-2x/b+x^2/b^2$	0+0	$1/3Xb/EJ$	
ED b	$-x/b$	0	0	0	0	x^2/b^2			
EF b	0	0	0	0	0	0	0+0	0	
FE b	0	0	0	0	0	0			
FG b	0	$1/2Fx-1/2qx^2$	0	0	0	0	0+0	0	
GF b	0	$-1/2Fx+1/2qx^2$	0	0	0	0			
GC b	0	0	0	0	0	0	0+0	0	
CG b	0	0	0	0	0	0			
HG b	0	0	0	0	0	0	0+0	0	
GH b	0	0	0	0	0	0			
HB b	0	$-1/2Fb+Fx-1/2qx^2$	0	0	0	0	0+0	0	
BH b	0	$1/2qx^2$	0	0	0	0			
HE b	0	$1/2Fb-1/2Fx$	0	0	0	0	0+0	0	
EH b	0	$-1/2Fx$	0	0	0	0			
AB	molla asta $-W_{1AB} (W_{0AB} + XW_{1AB})/k_{AB}$								$1/4Xb/EJ$
	totali							$7/24Fb^2/EJ$	$35/12Xb/EJ$
	iperstatica $X=W_{AB}$							$-1/10Fb$	

Sviluppi di calcolo iperstatica

$$L_{AB}^{xx} = \int_0^b (1 - 2x/b + x^2/b^2) \frac{1}{EJ} dx + 1 \cdot 1 \cdot \frac{1}{4} \frac{b}{EJ} = \left[x - \frac{x^2}{b} + \frac{1}{3} \frac{x^3}{b^2} \right]_0^b \frac{1}{EJ} + 1 \cdot 1 \cdot \frac{1}{4} \frac{b}{EJ}$$

$$= (b - b + \frac{1}{3}b) \frac{1}{EJ} + 1 \cdot 1 \cdot \frac{1}{4} \frac{b}{EJ} = \frac{7}{12} \frac{b}{EJ}$$

$$L_{BA}^{xx} = \int_0^b (x^2/b^2) \frac{1}{EJ} dx + 1 \cdot 1 \cdot \frac{1}{4} \frac{b}{EJ} = \left[\frac{1}{3} \frac{x^3}{b^2} \right]_0^b \frac{1}{EJ} + 1 \cdot 1 \cdot \frac{1}{4} \frac{b}{EJ}$$

$$= (\frac{1}{3}b) \frac{1}{EJ} + 1 \cdot 1 \cdot \frac{1}{4} \frac{b}{EJ} = \frac{7}{12} \frac{b}{EJ}$$

$$L_{AD}^{xx} = \int_0^{2b} (1) \frac{1}{EJ} dx = \left[x \right]_0^{2b} \frac{1}{EJ}$$

$$= (2b) \frac{1}{EJ} = 2 \frac{b}{EJ}$$

$$L_{DA}^{xx} = \int_0^{2b} (1) \frac{1}{EJ} dx = \left[x \right]_0^{2b} \frac{1}{EJ}$$

$$= (2b) \frac{1}{EJ} = 2 \frac{b}{EJ}$$

$$L_{DE}^{xx} = \int_0^b (1 - 2x/b + x^2/b^2) \frac{1}{EJ} dx = \left[x - \frac{x^2}{b} + \frac{1}{3} \frac{x^3}{b^2} \right]_0^b \frac{1}{EJ}$$

$$= (b - b + \frac{1}{3}b) \frac{1}{EJ} = \frac{1}{3} \frac{b}{EJ}$$

$$L_{ED}^{xx} = \int_0^b (x^2/b^2) \frac{1}{EJ} dx = \left[\frac{1}{3} \frac{x^3}{b^2} \right]_0^b \frac{1}{EJ}$$

$$= (\frac{1}{3}b) \frac{1}{EJ} = \frac{1}{3} \frac{b}{EJ}$$

$$L_{AB}^{xo} = \int_0^b (3/2 x/b - x^2/b^2 - 1/2 x^3/b^3) Fb \frac{1}{EJ} dx + 1 \cdot 0 \cdot \frac{1}{4} \frac{Fb^2}{EJ}$$

$$= \left[\frac{3}{4} \frac{x^2}{b} - \frac{1}{3} \frac{x^3}{b^2} - \frac{1}{8} \frac{x^4}{b^3} \right]_0^b Fb \frac{1}{EJ} + 1 \cdot 0 \cdot \frac{1}{4} \frac{Fb^2}{EJ}$$

$$= (\frac{3}{4}b - \frac{1}{3}b - \frac{1}{8}b) Fb \frac{1}{EJ} + 1 \cdot 0 \cdot \frac{1}{4} \frac{Fb^2}{EJ} = \frac{7}{24} \frac{Fb^2}{EJ}$$

$$L_{BA}^{xo} = \int_0^b (2x/b - 5/2 x^2/b^2 + 1/2 x^3/b^3) Fb \frac{1}{EJ} dx + 1 \cdot 0 \cdot \frac{1}{4} \frac{Fb^2}{EJ}$$

$$= \left[\frac{x^2}{b} - \frac{5}{6} \frac{x^3}{b^2} + \frac{1}{8} \frac{x^4}{b^3} \right]_0^b Fb \frac{1}{EJ} + 1 \cdot 0 \cdot \frac{1}{4} \frac{Fb^2}{EJ}$$

$$= (b - \frac{5}{6}b + \frac{1}{8}b) Fb \frac{1}{EJ} + 1 \cdot 0 \cdot \frac{1}{4} \frac{Fb^2}{EJ} = \frac{7}{24} \frac{Fb^2}{EJ}$$

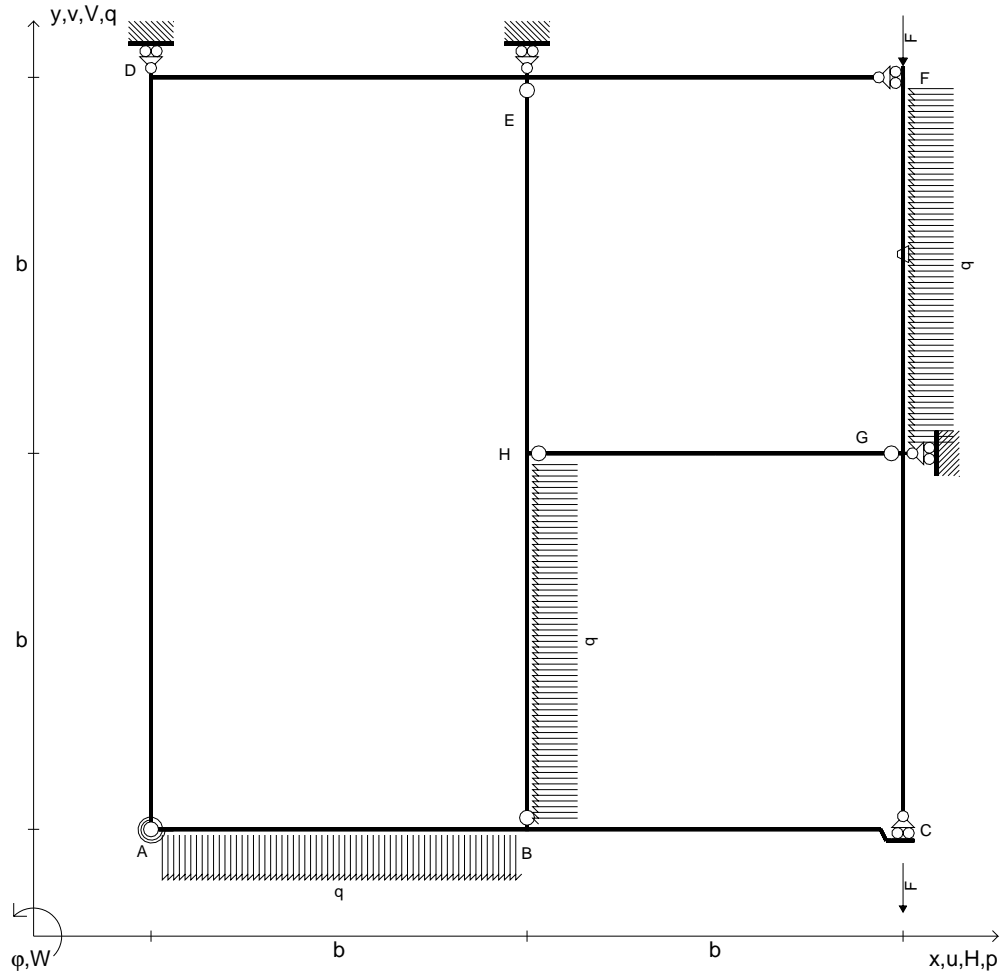

$V_{FG} = -F$	$k_{AB} = 4EJ/b$	$EJ_{FG} = EJ$
$V_{CB} = -F$	$EJ_{AB} = EJ$	$EJ_{GC} = EJ$
$q_{AB} = -q = -F/b$	$EJ_{BC} = EJ$	$EJ_{HG} = EJ$
$p_{HB} = -q = -F/b$	$EJ_{AD} = EJ$	$EJ_{HB} = EJ$
$p_{FG} = -q = -F/b$	$EJ_{DE} = EJ$	$EJ_{HE} = EJ$
$\theta_{FG} = -\theta = -\alpha T/b = -bF/EJ$	$EJ_{EF} = EJ$	

Reazioni iperstatiche in soluzione: $X=W_{AB}$

Carichi e deformazioni date hanno verso efficace in disegno.

Calcolare reazioni vincolari della struttura e delle aste.

Tracciare i diagrammi quotati delle azioni interne nelle aste.

$J_{YZ} - x_{YZ} - \theta_{YZ}$ riferimento locale asta YZ con origine in Y.

Curvatura θ asta FG positiva se convessa a destra con inizio F.

@ Adolfo Zavelani Rossi, Politecnico di Milano, vers.27.03.13

08.01.25

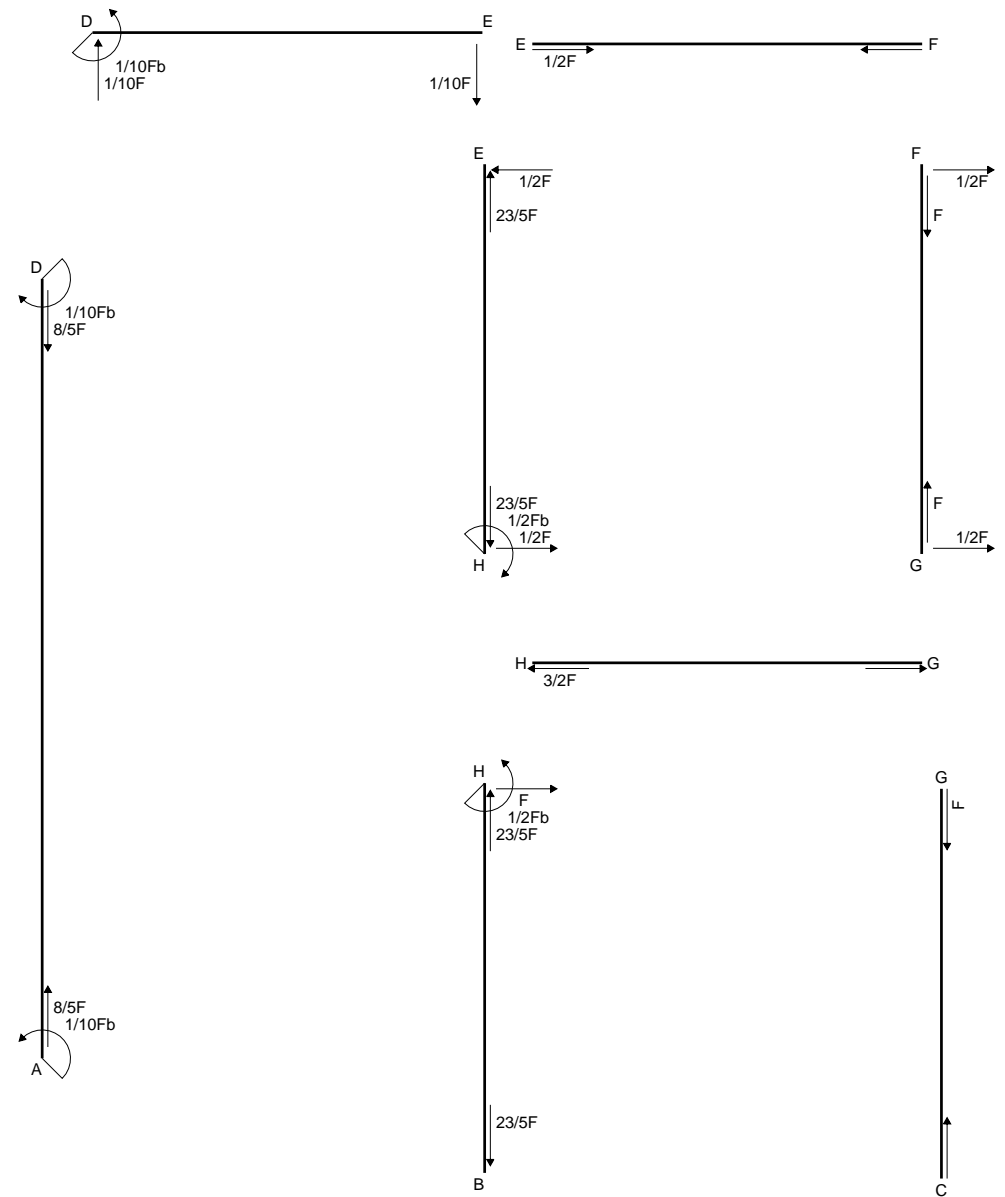

@ Adolfo Zavelani Rossi, Politecnico di Milano, vers.27.03.13

08.01.25

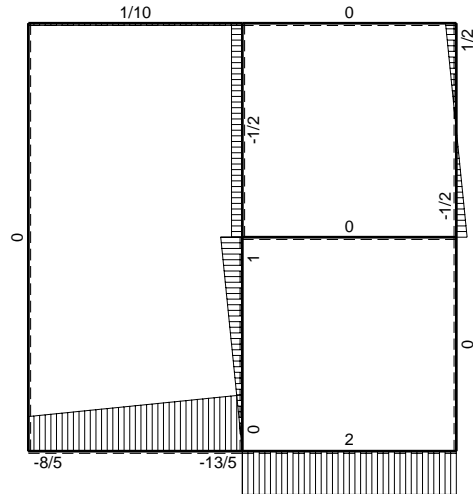
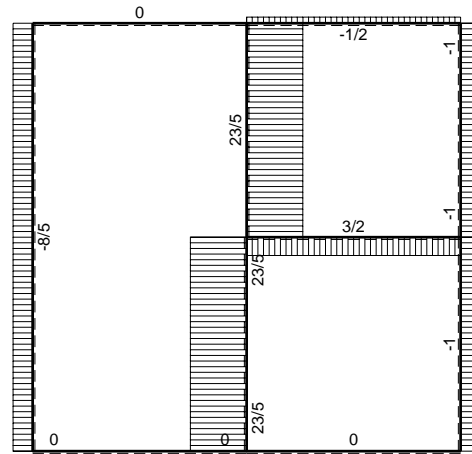

← ⊕ → F

↑ ⊕ ↓ F

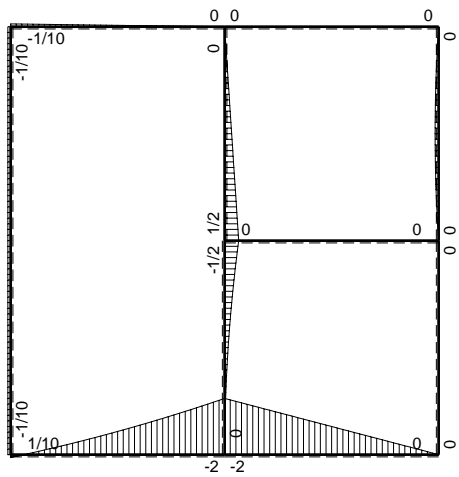

⊕ F_b

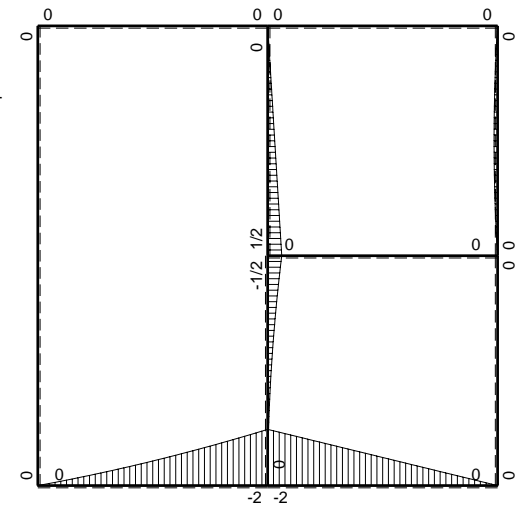
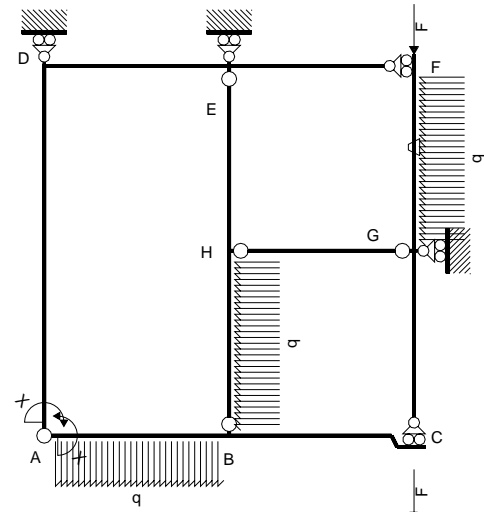

Schema di calcolo iperstatico

⊕ M₀ flessione da carichi assegnati

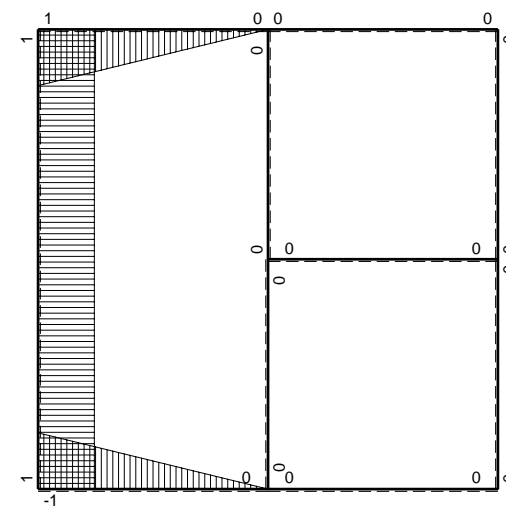

⊕ M_x flessione da iperstatica X=1

Quadro contributi PLV per iperstatica $X=W_{AB}$

→	$M_x(x)$	$M_o(x)$	θ	$M_x M_o$	$M_x \theta$	$M_x M_x$	$\int M_x(M_o/EJ+\theta)dx$	$\int X M_x M_x/EJ dx$	
AB b	$-1+x/b$	$-3/2Fx-1/2qx^2$	0	$3/2Fx-Fx^2/b-1/2qx^3/b$	0	$1-2x/b+x^2/b^2$	$(7/24+0)Fb^2/EJ$	$1/3Xb/EJ$	
BA b	x/b	$2Fb-5/2Fx+1/2qx^2$	0	$2Fx-5/2Fx^2/b+1/2qx^3/b$	0	x^2/b^2			
BC b	0	$-2Fb+2Fx$	0	0	0	0	0+0	0	
CB b	0	$2Fx$	0	0	0	0			
AD 2b	1	0	0	0	0	1	0+0	$2Xb/EJ$	
DA 2b	-1	0	0	0	0	1			
DE b	$1-x/b$	0	0	0	0	$1-2x/b+x^2/b^2$	0+0	$1/3Xb/EJ$	
ED b	$-x/b$	0	0	0	0	x^2/b^2			
EF b	0	0	0	0	0	0	0+0	0	
FE b	0	0	0	0	0	0			
FG b	0	$1/2Fx-1/2qx^2$	$-Fb/EJ$	0	0	0	0+0	0	
GF b	0	$-1/2Fx+1/2qx^2$	Fb/EJ	0	0	0			
GC b	0	0	0	0	0	0	0+0	0	
CG b	0	0	0	0	0	0			
HG b	0	0	0	0	0	0	0+0	0	
GH b	0	0	0	0	0	0			
HB b	0	$-1/2Fb+Fx-1/2qx^2$	0	0	0	0	0+0	0	
BH b	0	$1/2qx^2$	0	0	0	0			
HE b	0	$1/2Fb-1/2Fx$	0	0	0	0	0+0	0	
EH b	0	$-1/2Fx$	0	0	0	0			
AB	molla asta $-W_{1AB} (W_{0AB} + XW_{1AB})/k_{AB}$								$1/4Xb/EJ$
	totali							$7/24Fb^2/EJ$	$35/12Xb/EJ$
	iperstatica $X=W_{AB}$							$-1/10Fb$	

Sviluppi di calcolo iperstatica

$$L_{AB}^{xx} = \int_0^b (1 - 2x/b + x^2/b^2) \frac{1}{EJ} dx + 1 \cdot 1/4 \cdot b/EJ = \left[x - x^2/b + 1/3 x^3/b^2 \right]_0^b \frac{1}{EJ} + 1 \cdot 1/4 \cdot b/EJ$$

$$= (b - b + 1/3 b) \frac{1}{EJ} + 1 \cdot 1/4 \cdot b/EJ = 7/12 \cdot b/EJ$$

$$L_{BA}^{xx} = \int_0^b (x^2/b^2) \frac{1}{EJ} dx + 1 \cdot 1/4 \cdot b/EJ = \left[1/3 x^3/b^2 \right]_0^b \frac{1}{EJ} + 1 \cdot 1/4 \cdot b/EJ$$

$$= (1/3 b) \frac{1}{EJ} + 1 \cdot 1/4 \cdot b/EJ = 7/12 \cdot b/EJ$$

$$L_{AD}^{xx} = \int_0^{2b} (1) \frac{1}{EJ} dx = \left[x \right]_0^{2b} \frac{1}{EJ}$$

$$= (2b) \frac{1}{EJ} = 2 \cdot b/EJ$$

$$L_{DA}^{xx} = \int_0^{2b} (1) \frac{1}{EJ} dx = \left[x \right]_0^{2b} \frac{1}{EJ}$$

$$= (2b) \frac{1}{EJ} = 2 \cdot b/EJ$$

$$L_{DE}^{xx} = \int_0^b (1 - 2x/b + x^2/b^2) \frac{1}{EJ} dx = \left[x - x^2/b + 1/3 x^3/b^2 \right]_0^b \frac{1}{EJ}$$

$$= (b - b + 1/3 b) \frac{1}{EJ} = 1/3 \cdot b/EJ$$

$$L_{ED}^{xx} = \int_0^b (x^2/b^2) \frac{1}{EJ} dx = \left[1/3 x^3/b^2 \right]_0^b \frac{1}{EJ}$$

$$= (1/3 b) \frac{1}{EJ} = 1/3 \cdot b/EJ$$

$$L_{AB}^{xo} = \int_0^b (3/2 x/b - x^2/b^2 - 1/2 x^3/b^3) Fb \frac{1}{EJ} dx + 1 \cdot 0 \cdot 1/4 \cdot Fb^2/EJ$$

$$= \left[3/4 x^2/b - 1/3 x^3/b^2 - 1/8 x^4/b^3 \right]_0^b Fb \frac{1}{EJ} + 1 \cdot 0 \cdot 1/4 \cdot Fb^2/EJ$$

$$= (3/4 b - 1/3 b - 1/8 b) Fb \frac{1}{EJ} + 1 \cdot 0 \cdot 1/4 \cdot Fb^2/EJ = 7/24 \cdot Fb^2/EJ$$

$$L_{BA}^{xo} = \int_0^b (2x/b - 5/2 x^2/b^2 + 1/2 x^3/b^3) Fb \frac{1}{EJ} dx + 1 \cdot 0 \cdot 1/4 \cdot Fb^2/EJ$$

$$= \left[x^2/b - 5/6 x^3/b^2 + 1/8 x^4/b^3 \right]_0^b Fb \frac{1}{EJ} + 1 \cdot 0 \cdot 1/4 \cdot Fb^2/EJ$$

$$= (b - 5/6 b + 1/8 b) Fb \frac{1}{EJ} + 1 \cdot 0 \cdot 1/4 \cdot Fb^2/EJ = 7/24 \cdot Fb^2/EJ$$

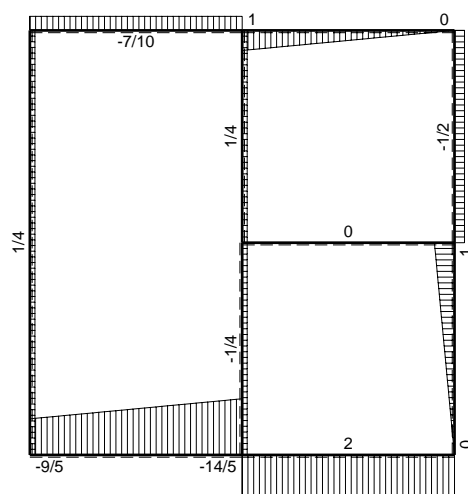
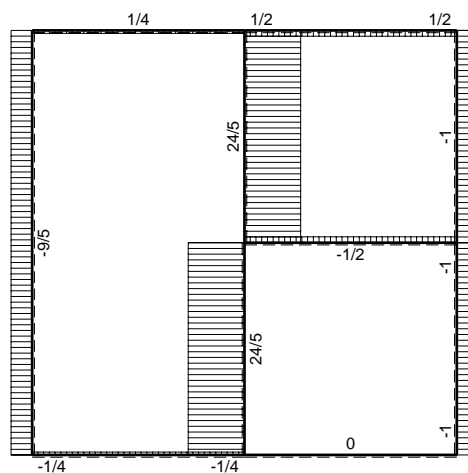

← ⊕ → F

↑ ⊕ ↓ F

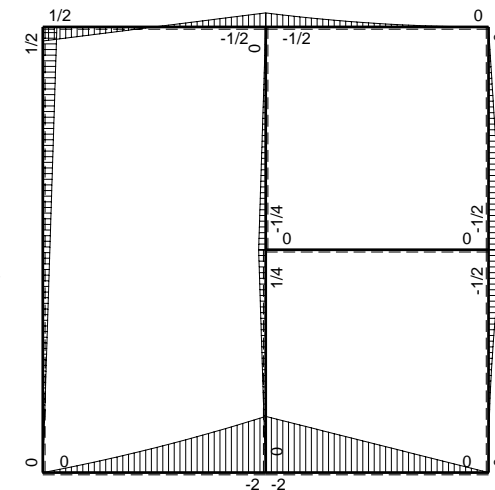
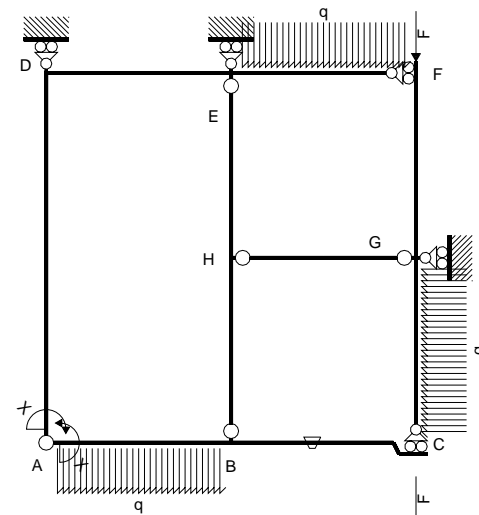

⊕ Mo flessione da carichi assegnati

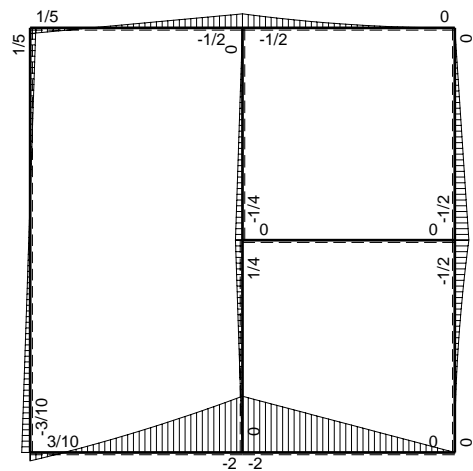

⊕ Fb

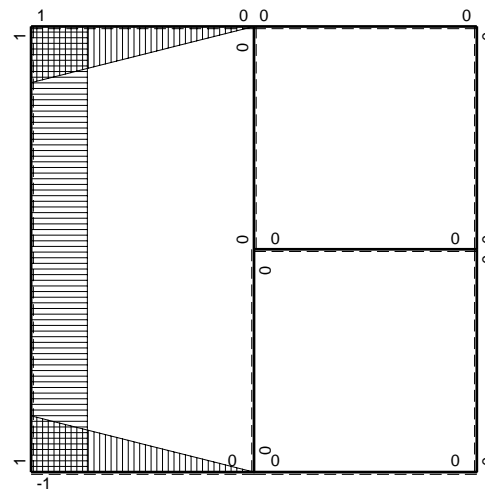

⊕ Mx flessione da iperstatica X=1

Quadro contributi PLV per iperstatica $X=W_{AB}$

→	$M_x(x)$	$M_o(x)$	θ	$M_x M_o$	$M_x \theta$	$M_x M_x$	$\int M_x(M_o/EJ+\theta)dx$	$\int X M_x M_x / EJ dx$	
AB b	$-1+x/b$	$-3/2Fx-1/2qx^2$	0	$3/2Fx-Fx^2/b-1/2qx^3/b$	0	$1-2x/b+x^2/b^2$	$(7/24+0)Fb^2/EJ$	$1/3Xb/EJ$	
BA b	x/b	$2Fb-5/2Fx+1/2qx^2$	0	$2Fx-5/2Fx^2/b+1/2qx^3/b$	0	x^2/b^2			
BC b	0	$-2Fb+2Fx$	$-Fb/EJ$	0	0	0	0+0	0	
CB b	0	$2Fx$	Fb/EJ	0	0	0			
AD 2b	1	$1/4Fx$	0	$1/4Fx$	0	1	$(1/2+0)Fb^2/EJ$	$2Xb/EJ$	
DA 2b	-1	$-1/2Fb+1/4Fx$	0	$1/2Fb-1/4Fx$	0	1			
DE b	$1-x/b$	$1/2Fb-Fx$	0	$1/2Fb-3/2Fx+Fx^2/b$	0	$1-2x/b+x^2/b^2$	$(1/12+0)Fb^2/EJ$	$1/3Xb/EJ$	
ED b	$-x/b$	$1/2Fb-Fx$	0	$-1/2Fx+Fx^2/b$	0	x^2/b^2			
EF b	0	$-1/2Fb+Fx-1/2qx^2$	0	0	0	0	0+0	0	
FE b	0	$1/2qx^2$	0	0	0	0			
FG b	0	$-1/2Fx$	0	0	0	0	0+0	0	
GF b	0	$1/2Fb-1/2Fx$	0	0	0	0			
GC b	0	$-1/2Fb+Fx-1/2qx^2$	0	0	0	0	0+0	0	
CG b	0	$1/2qx^2$	0	0	0	0			
HG b	0	0	0	0	0	0	0+0	0	
GH b	0	0	0	0	0	0			
HB b	0	$1/4Fb-1/4Fx$	0	0	0	0	0+0	0	
BH b	0	$-1/4Fx$	0	0	0	0			
HE b	0	$-1/4Fb+1/4Fx$	0	0	0	0	0+0	0	
EH b	0	$1/4Fx$	0	0	0	0			
AB	molla asta $-W_{1AB}(W_{0AB}+XW_{1AB})/k_{AB}$								$1/4Xb/EJ$
	totali							$7/8Fb^2/EJ$	$35/12Xb/EJ$
	iperstatica $X=W_{AB}$							$-3/10Fb$	

Sviluppi di calcolo iperstatica

$$L_{AB}^{xx} = \int_0^b (1 - 2x/b + x^2/b^2) \cdot 1/EJ \, dx + 1 \cdot 1/4 \cdot b/EJ = \left[x - x^2/b + 1/3 x^3/b^2 \right]_0^b \cdot 1/EJ + 1 \cdot 1/4 \cdot b/EJ$$

$$= (b - b + 1/3 b) \cdot 1/EJ + 1 \cdot 1/4 \cdot b/EJ = 7/12 \cdot b/EJ$$

$$L_{BA}^{xx} = \int_0^b (x^2/b^2) \cdot 1/EJ \, dx + 1 \cdot 1/4 \cdot b/EJ = \left[1/3 x^3/b^2 \right]_0^b \cdot 1/EJ + 1 \cdot 1/4 \cdot b/EJ$$

$$= (1/3 b) \cdot 1/EJ + 1 \cdot 1/4 \cdot b/EJ = 7/12 \cdot b/EJ$$

$$L_{AD}^{xx} = \int_0^{2b} (1) \cdot 1/EJ \, dx = \left[x \right]_0^{2b} \cdot 1/EJ$$

$$= (2b) \cdot 1/EJ = 2 \cdot b/EJ$$

$$L_{DA}^{xx} = \int_0^{2b} (1) \cdot 1/EJ \, dx = \left[x \right]_0^{2b} \cdot 1/EJ$$

$$= (2b) \cdot 1/EJ = 2 \cdot b/EJ$$

$$L_{DE}^{xx} = \int_0^b (1 - 2x/b + x^2/b^2) \cdot 1/EJ \, dx = \left[x - x^2/b + 1/3 x^3/b^2 \right]_0^b \cdot 1/EJ$$

$$= (b - b + 1/3 b) \cdot 1/EJ = 1/3 \cdot b/EJ$$

$$L_{ED}^{xx} = \int_0^b (x^2/b^2) \cdot 1/EJ \, dx = \left[1/3 x^3/b^2 \right]_0^b \cdot 1/EJ$$

$$= (1/3 b) \cdot 1/EJ = 1/3 \cdot b/EJ$$

$$L_{AB}^{xo} = \int_0^b (3/2 x/b - x^2/b^2 - 1/2 x^3/b^3) \cdot Fb \cdot 1/EJ \, dx + 1 \cdot 0 \cdot 1/4 \cdot Fb^2/EJ$$

$$= \left[3/4 x^2/b - 1/3 x^3/b^2 - 1/8 x^4/b^3 \right]_0^b \cdot Fb \cdot 1/EJ + 1 \cdot 0 \cdot 1/4 \cdot Fb^2/EJ$$

$$= (3/4 b - 1/3 b - 1/8 b) \cdot Fb \cdot 1/EJ + 1 \cdot 0 \cdot 1/4 \cdot Fb^2/EJ = 7/24 \cdot Fb^2/EJ$$

$$L_{BA}^{xo} = \int_0^b (2x/b - 5/2 x^2/b^2 + 1/2 x^3/b^3) \cdot Fb \cdot 1/EJ \, dx + 1 \cdot 0 \cdot 1/4 \cdot Fb^2/EJ$$

$$= \left[x^2/b - 5/6 x^3/b^2 + 1/8 x^4/b^3 \right]_0^b \cdot Fb \cdot 1/EJ + 1 \cdot 0 \cdot 1/4 \cdot Fb^2/EJ$$

$$= (b - 5/6 b + 1/8 b) \cdot Fb \cdot 1/EJ + 1 \cdot 0 \cdot 1/4 \cdot Fb^2/EJ = 7/24 \cdot Fb^2/EJ$$

$$L_{AD}^{xo} = \int_0^{2b} (1/4 x/b) \cdot Fb \cdot 1/EJ \, dx = \left[1/8 x^2/b \right]_0^{2b} \cdot Fb \cdot 1/EJ$$

$$= (1/2 b) \cdot Fb \cdot 1/EJ = 1/2 \cdot Fb^2/EJ$$

$$L_{DA}^{xo} = \int_0^{2b} (1/2 - 1/4 x/b) \cdot Fb \cdot 1/EJ \, dx = \left[1/2 x - 1/8 x^2/b \right]_0^{2b} \cdot Fb \cdot 1/EJ$$

$$= (b - 1/2 b) \cdot Fb \cdot 1/EJ = 1/2 \cdot Fb^2/EJ$$

$$L_{DE}^{xo} = \int_0^b (1/2 - 3/2 x/b + x^2/b^2) \cdot Fb \cdot 1/EJ \, dx = \left[1/2 x - 3/4 x^2/b + 1/3 x^3/b^2 \right]_0^b \cdot Fb \cdot 1/EJ$$

$$= (1/2 b - 3/4 b + 1/3 b) \cdot Fb \cdot 1/EJ = 1/12 \cdot Fb^2/EJ$$

$$L_{ED}^{xo} = \int_0^b (-1/2 x/b + x^2/b^2) \cdot Fb \cdot 1/EJ \, dx = \left[-1/4 x^2/b + 1/3 x^3/b^2 \right]_0^b \cdot Fb \cdot 1/EJ$$

$$= (-1/4 b + 1/3 b) \cdot Fb \cdot 1/EJ = 1/12 \cdot Fb^2/EJ$$

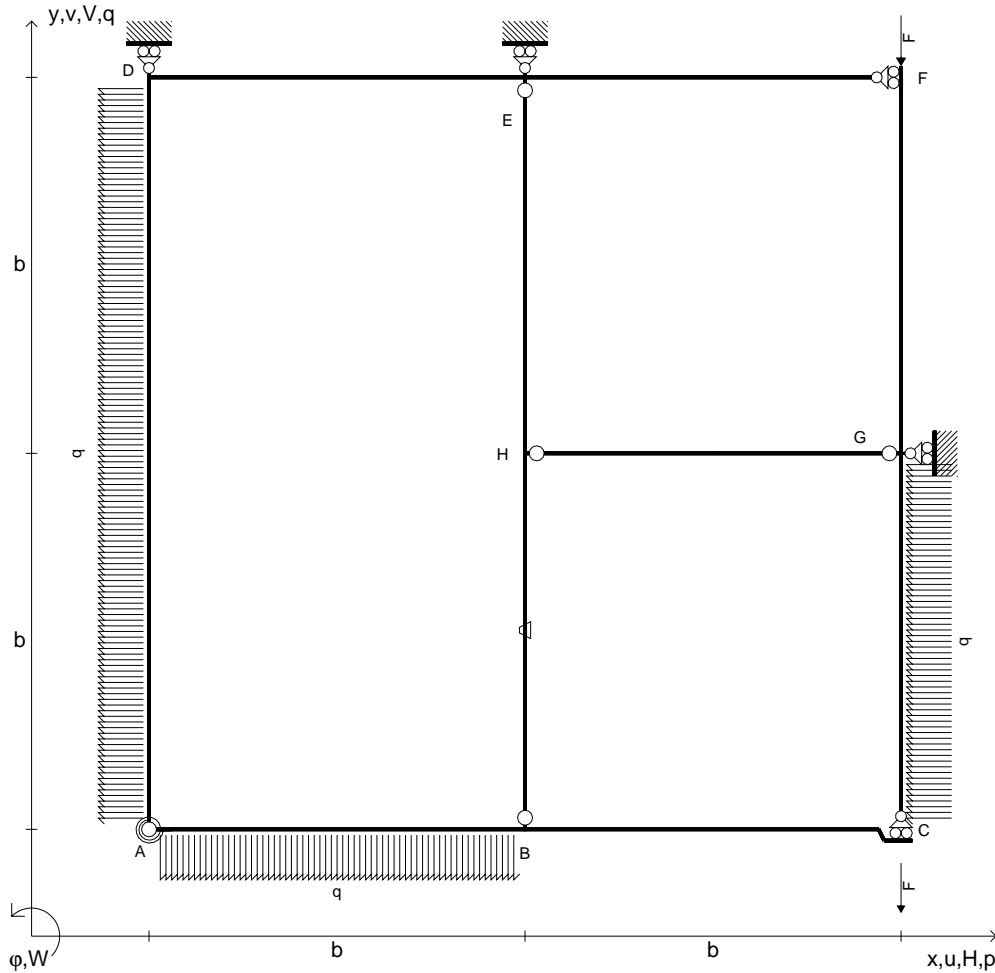

$V_{FG} = -F$	$k_{AB} = 4EJ/b$	$EJ_{FG} = EJ$
$V_{CB} = -F$	$EJ_{AB} = EJ$	$EJ_{GC} = EJ$
$q_{AB} = -q = -F/b$	$EJ_{BC} = EJ$	$EJ_{HG} = EJ$
$p_{GC} = -q = -F/b$	$EJ_{AD} = EJ$	$EJ_{HB} = EJ$
$p_{AD} = -q = -F/b$	$EJ_{DE} = EJ$	$EJ_{HE} = EJ$
$\theta_{HB} = -\theta = -\alpha T/b = -bF/EJ$	$EJ_{EF} = EJ$	

Reazioni iperstatiche in soluzione: $X=W_{AB}$

Carichi e deformazioni date hanno verso efficace in disegno.

Calcolare reazioni vincolari della struttura e delle aste.

Tracciare i diagrammi quotati delle azioni interne nelle aste.

$J_{YZ} - x_{YZ} - \theta_{YZ}$ riferimento locale asta YZ con origine in Y.

Curvatura θ asta HB positiva se convessa a destra con inizio H.

@ Adolfo Zavelani Rossi, Politecnico di Milano, vers.27.03.13

08.01.25

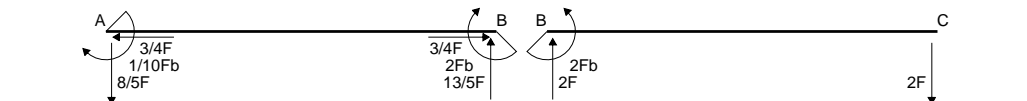
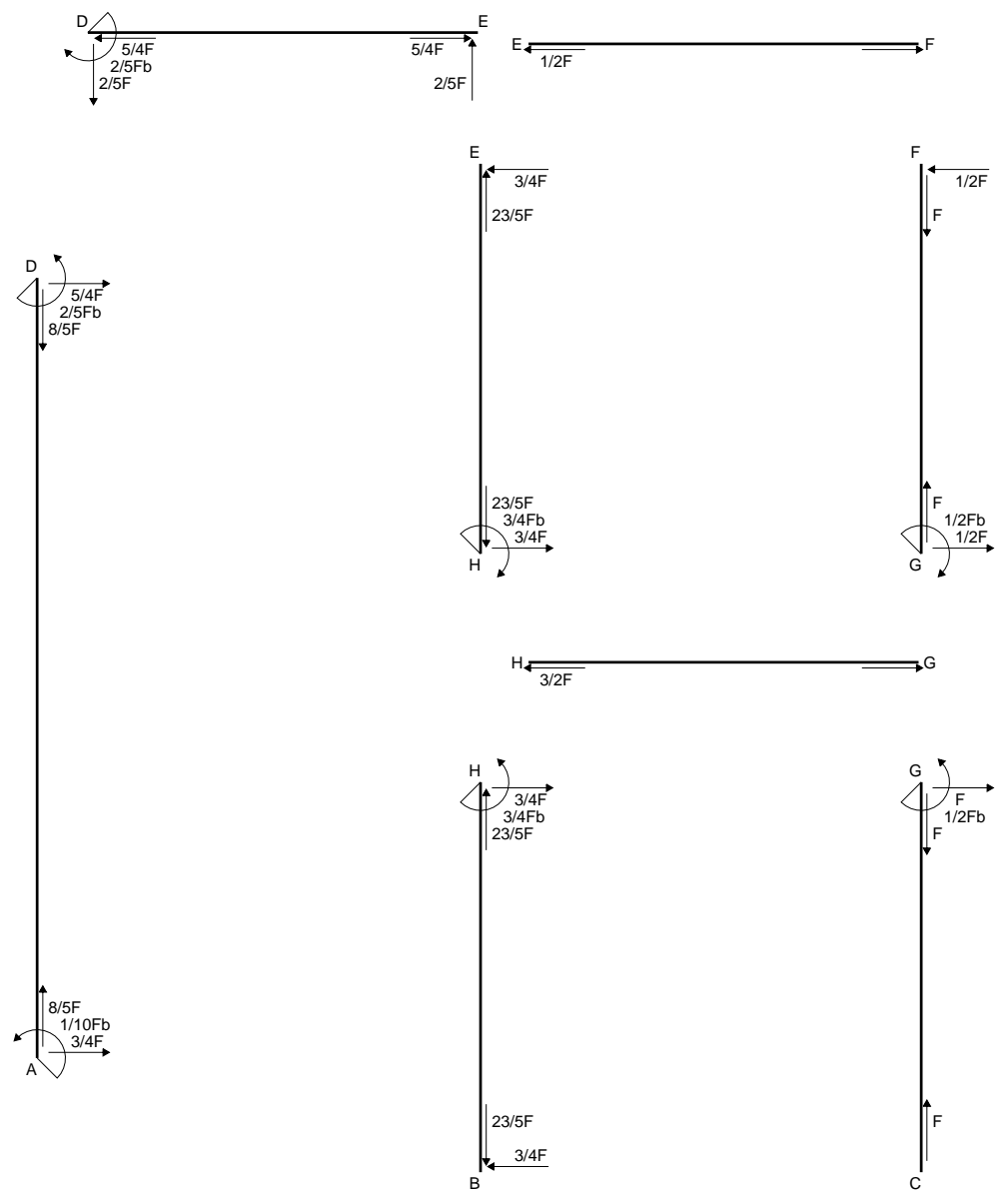

@ Adolfo Zavelani Rossi, Politecnico di Milano, vers.27.03.13

08.01.25

Quadro contributi PLV per iperstatica $X=W_{AB}$

→	$M_x(x)$	$M_o(x)$	θ	$M_x M_o$	$M_x \theta$	$M_x M_x$	$\int M_x(M_o/EJ+\theta)dx$	$\int X M_x M_x/EJ dx$
AB b	$-1+x/b$	$-3/2Fx-1/2qx^2$	0	$3/2Fx-Fx^2/b-1/2qx^3/b$	0	$1-2x/b+x^2/b^2$	$(7/24+0)Fb^2/EJ$	$1/3Xb/EJ$
BA b	x/b	$2Fb-5/2Fx+1/2qx^2$	0	$2Fx-5/2Fx^2/b+1/2qx^3/b$	0	x^2/b^2		
BC b	0	$-2Fb+2Fx$	0	0	0	0	0+0	0
CB b	0	$2Fx$	0	0	0	0		
AD 2b	1	$-3/4Fx+1/2qx^2$	0	$-3/4Fx+1/2Fx^2/b$	0	1	$(-1/6+0)Fb^2/EJ$	$2Xb/EJ$
DA 2b	-1	$-1/2Fb+5/4Fx-1/2qx^2$	0	$1/2Fb-5/4Fx+1/2Fx^2/b$	0	1		
DE b	$1-x/b$	$1/2Fb-1/2Fx$	0	$1/2Fb-Fx+1/2Fx^2/b$	0	$1-2x/b+x^2/b^2$	$(1/6+0)Fb^2/EJ$	$1/3Xb/EJ$
ED b	$-x/b$	$-1/2Fx$	0	$1/2Fx^2/b$	0	x^2/b^2		
EF b	0	0	0	0	0	0	0+0	0
FE b	0	0	0	0	0	0		
FG b	0	$-1/2Fx$	0	0	0	0	0+0	0
GF b	0	$1/2Fb-1/2Fx$	0	0	0	0		
GC b	0	$-1/2Fb+Fx-1/2qx^2$	0	0	0	0	0+0	0
CG b	0	$1/2qx^2$	0	0	0	0		
HG b	0	0	0	0	0	0	0+0	0
GH b	0	0	0	0	0	0		
HB b	0	$-3/4Fb+3/4Fx$	$-Fb/EJ$	0	0	0	0+0	0
BH b	0	$3/4Fx$	Fb/EJ	0	0	0		
HE b	0	$3/4Fb-3/4Fx$	0	0	0	0	0+0	0
EH b	0	$-3/4Fx$	0	0	0	0		
AB	molla asta $-W_{1AB}(W_{0AB}+XW_{1AB})/k_{AB}$							$1/4Xb/EJ$
	totali						$7/24Fb^2/EJ$	$35/12Xb/EJ$
	iperstatica $X=W_{AB}$						$-1/10Fb$	

Sviluppi di calcolo iperstatica

$$L_{AB}^{xx} = \int_0^b (1 - 2x/b + x^2/b^2) \cdot 1/EJ \, dx + 1 \cdot 1/4 \cdot b/EJ = \left[x - x^2/b + 1/3 x^3/b^2 \right]_0^b \cdot 1/EJ + 1 \cdot 1/4 \cdot b/EJ$$

$$= (b - b + 1/3 b) \cdot 1/EJ + 1 \cdot 1/4 \cdot b/EJ = 7/12 \cdot b/EJ$$

$$L_{BA}^{xx} = \int_0^b (x^2/b^2) \cdot 1/EJ \, dx + 1 \cdot 1/4 \cdot b/EJ = \left[1/3 x^3/b^2 \right]_0^b \cdot 1/EJ + 1 \cdot 1/4 \cdot b/EJ$$

$$= (1/3 b) \cdot 1/EJ + 1 \cdot 1/4 \cdot b/EJ = 7/12 \cdot b/EJ$$

$$L_{AD}^{xx} = \int_0^{2b} (1) \cdot 1/EJ \, dx = \left[x \right]_0^{2b} \cdot 1/EJ$$

$$= (2b) \cdot 1/EJ = 2 \cdot b/EJ$$

$$L_{DA}^{xx} = \int_0^{2b} (1) \cdot 1/EJ \, dx = \left[x \right]_0^{2b} \cdot 1/EJ$$

$$= (2b) \cdot 1/EJ = 2 \cdot b/EJ$$

$$L_{DE}^{xx} = \int_0^b (1 - 2x/b + x^2/b^2) \cdot 1/EJ \, dx = \left[x - x^2/b + 1/3 x^3/b^2 \right]_0^b \cdot 1/EJ$$

$$= (b - b + 1/3 b) \cdot 1/EJ = 1/3 \cdot b/EJ$$

$$L_{ED}^{xx} = \int_0^b (x^2/b^2) \cdot 1/EJ \, dx = \left[1/3 x^3/b^2 \right]_0^b \cdot 1/EJ$$

$$= (1/3 b) \cdot 1/EJ = 1/3 \cdot b/EJ$$

$$L_{AB}^{xo} = \int_0^b (3/2 x/b - x^2/b^2 - 1/2 x^3/b^3) \cdot Fb \cdot 1/EJ \, dx + 1 \cdot 0 \cdot 1/4 \cdot Fb^2/EJ$$

$$= \left[3/4 x^2/b - 1/3 x^3/b^2 - 1/8 x^4/b^3 \right]_0^b \cdot Fb \cdot 1/EJ + 1 \cdot 0 \cdot 1/4 \cdot Fb^2/EJ$$

$$= (3/4 b - 1/3 b - 1/8 b) \cdot Fb \cdot 1/EJ + 1 \cdot 0 \cdot 1/4 \cdot Fb^2/EJ = 7/24 \cdot Fb^2/EJ$$

$$L_{BA}^{xo} = \int_0^b (2x/b - 5/2 x^2/b^2 + 1/2 x^3/b^3) \cdot Fb \cdot 1/EJ \, dx + 1 \cdot 0 \cdot 1/4 \cdot Fb^2/EJ$$

$$= \left[x^2/b - 5/6 x^3/b^2 + 1/8 x^4/b^3 \right]_0^b \cdot Fb \cdot 1/EJ + 1 \cdot 0 \cdot 1/4 \cdot Fb^2/EJ$$

$$= (b - 5/6 b + 1/8 b) \cdot Fb \cdot 1/EJ + 1 \cdot 0 \cdot 1/4 \cdot Fb^2/EJ = 7/24 \cdot Fb^2/EJ$$

$$L_{AD}^{xo} = \int_0^{2b} (-3/4 x/b + 1/2 x^2/b^2) \cdot Fb \cdot 1/EJ \, dx = \left[-3/8 x^2/b + 1/6 x^3/b^2 \right]_0^{2b} \cdot Fb \cdot 1/EJ$$

$$= (-3/2 b + 4/3 b) \cdot Fb \cdot 1/EJ = -1/6 \cdot Fb^2/EJ$$

$$L_{DA}^{xo} = \int_0^{2b} (1/2 - 5/4 x/b + 1/2 x^2/b^2) \cdot Fb \cdot 1/EJ \, dx = \left[1/2 x - 5/8 x^2/b + 1/6 x^3/b^2 \right]_0^{2b} \cdot Fb \cdot 1/EJ$$

$$= (b - 5/2 b + 4/3 b) \cdot Fb \cdot 1/EJ = -1/6 \cdot Fb^2/EJ$$

$$L_{DE}^{xo} = \int_0^b (1/2 - x/b + 1/2 x^2/b^2) \cdot Fb \cdot 1/EJ \, dx = \left[1/2 x - 1/2 x^2/b + 1/6 x^3/b^2 \right]_0^b \cdot Fb \cdot 1/EJ$$

$$= (1/2 b - 1/2 b + 1/6 b) \cdot Fb \cdot 1/EJ = 1/6 \cdot Fb^2/EJ$$

$$L_{ED}^{xo} = \int_0^b (1/2 x^2/b^2) \cdot Fb \cdot 1/EJ \, dx = \left[1/6 x^3/b^2 \right]_0^b \cdot Fb \cdot 1/EJ$$

$$= (1/6 b) \cdot Fb \cdot 1/EJ = 1/6 \cdot Fb^2/EJ$$

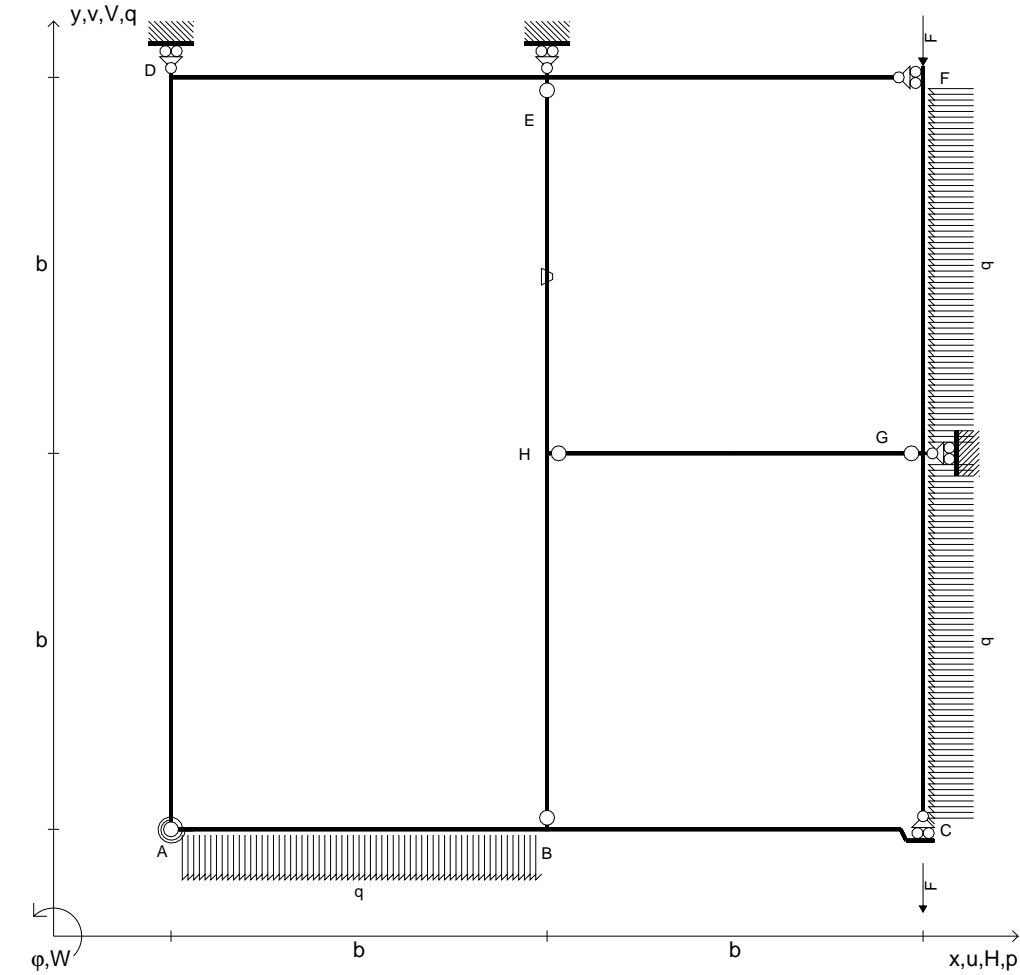

$V_{FG} = -F$	$k_{AB} = 4EJ/b$	$EJ_{FG} = EJ$
$V_{CB} = -F$	$EJ_{AB} = EJ$	$EJ_{GC} = EJ$
$q_{AB} = -q = -F/b$	$EJ_{BC} = EJ$	$EJ_{HG} = EJ$
$p_{GC} = -q = -F/b$	$EJ_{AD} = EJ$	$EJ_{HB} = EJ$
$p_{FG} = -q = -F/b$	$EJ_{DE} = EJ$	$EJ_{HE} = EJ$
$\theta_{HE} = -\theta = -\alpha T/b = -bF/EJ$	$EJ_{EF} = EJ$	

Reazioni iperstatiche in soluzione: $X=W_{AB}$

Carichi e deformazioni date hanno verso efficace in disegno.

Calcolare reazioni vincolari della struttura e delle aste.

Tracciare i diagrammi quotati delle azioni interne nelle aste.

$J_{YZ} - x_{YZ} - \theta_{YZ}$ riferimento locale asta YZ con origine in Y.

Curvatura θ asta HE positiva se convessa a destra con inizio H.

@ Adolfo Zavelani Rossi, Politecnico di Milano, vers.27.03.13

08.01.25

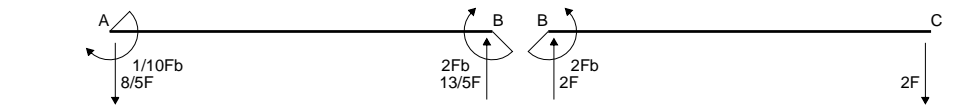
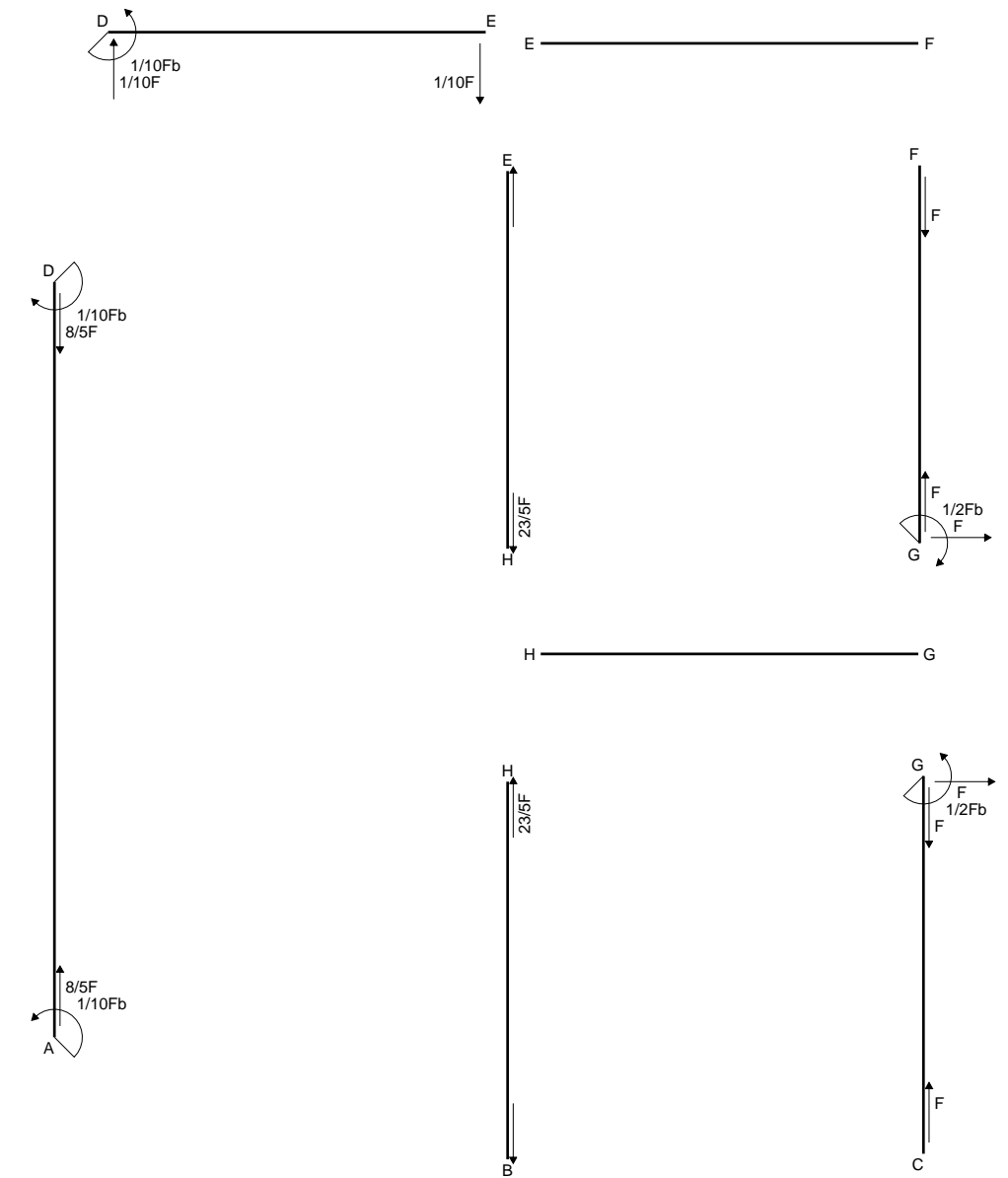

@ Adolfo Zavelani Rossi, Politecnico di Milano, vers.27.03.13

08.01.25

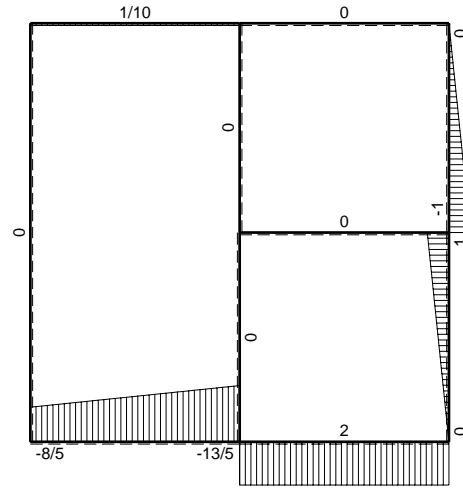
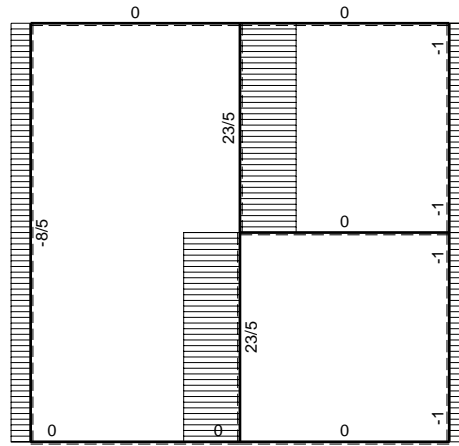

← ⊕ → F

↑ ⊕ ↓ F

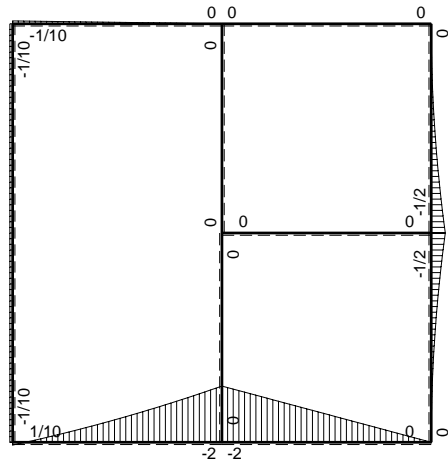

⊕ F_b

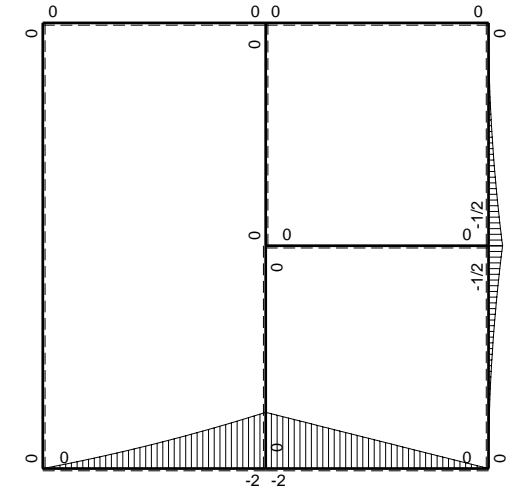
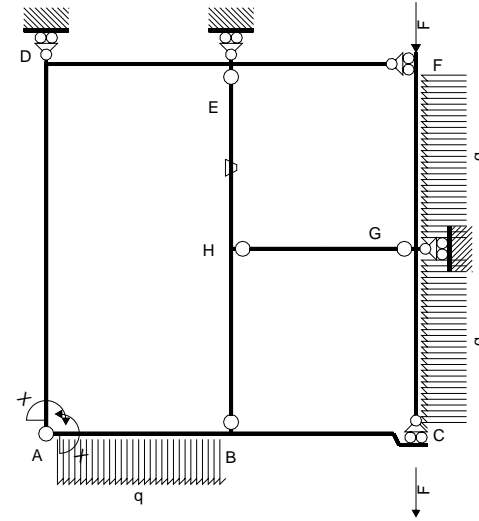

⊕ M₀ flessione da carichi assegnati

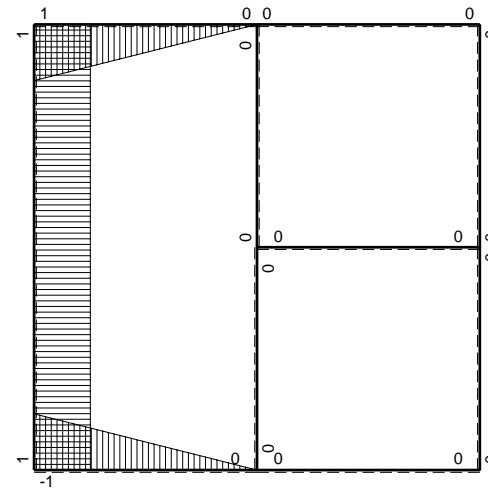

⊕ M_x flessione da iperstatica X=1

Quadro contributi PLV per iperstatica $X=W_{AB}$

→	$M_x(x)$	$M_o(x)$	θ	$M_x M_o$	$M_x \theta$	$M_x M_x$	$\int M_x(M_o/EJ+\theta)dx$	$\int X M_x M_x/EJ dx$	
AB b	$-1+x/b$	$-3/2Fx-1/2qx^2$	0	$3/2Fx-Fx^2/b-1/2qx^3/b$	0	$1-2x/b+x^2/b^2$	$(7/24+0)Fb^2/EJ$	$1/3Xb/EJ$	
BA b	x/b	$2Fb-5/2Fx+1/2qx^2$	0	$2Fx-5/2Fx^2/b+1/2qx^3/b$	0	x^2/b^2			
BC b	0	$-2Fb+2Fx$	0	0	0	0	0+0	0	
CB b	0	$2Fx$	0	0	0	0			
AD 2b	1	0	0	0	0	1	0+0	$2Xb/EJ$	
DA 2b	-1	0	0	0	0	1			
DE b	$1-x/b$	0	0	0	0	$1-2x/b+x^2/b^2$	0+0	$1/3Xb/EJ$	
ED b	$-x/b$	0	0	0	0	x^2/b^2			
EF b	0	0	0	0	0	0	0+0	0	
FE b	0	0	0	0	0	0			
FG b	0	$-1/2qx^2$	0	0	0	0	0+0	0	
GF b	0	$1/2Fb-Fx+1/2qx^2$	0	0	0	0			
GC b	0	$-1/2Fb+Fx-1/2qx^2$	0	0	0	0	0+0	0	
CG b	0	$1/2qx^2$	0	0	0	0			
HG b	0	0	0	0	0	0	0+0	0	
GH b	0	0	0	0	0	0			
HB b	0	0	0	0	0	0	0+0	0	
BH b	0	0	0	0	0	0			
HE b	0	0	$-Fb/EJ$	0	0	0	0+0	0	
EH b	0	0	Fb/EJ	0	0	0			
AB	molla asta $-W_{1AB}(W_{0AB}+XW_{1AB})/k_{AB}$								$1/4Xb/EJ$
	totali							$7/24Fb^2/EJ$	$35/12Xb/EJ$
	iperstatica $X=W_{AB}$							$-1/10Fb$	

Sviluppi di calcolo iperstatica

$$L_{AB}^{xx} = \int_0^b (1 - 2x/b + x^2/b^2) \frac{1}{EJ} dx + 1 \cdot 1 \cdot \frac{1}{4} \frac{b}{EJ} = \left[x - \frac{x^2}{b} + \frac{1}{3} \frac{x^3}{b^2} \right]_0^b \frac{1}{EJ} + 1 \cdot 1 \cdot \frac{1}{4} \frac{b}{EJ}$$

$$= (b - b + \frac{1}{3}b) \frac{1}{EJ} + 1 \cdot 1 \cdot \frac{1}{4} \frac{b}{EJ} = \frac{7}{12} \frac{b}{EJ}$$

$$L_{BA}^{xx} = \int_0^b (x^2/b^2) \frac{1}{EJ} dx + 1 \cdot 1 \cdot \frac{1}{4} \frac{b}{EJ} = \left[\frac{1}{3} \frac{x^3}{b^2} \right]_0^b \frac{1}{EJ} + 1 \cdot 1 \cdot \frac{1}{4} \frac{b}{EJ}$$

$$= (\frac{1}{3}b) \frac{1}{EJ} + 1 \cdot 1 \cdot \frac{1}{4} \frac{b}{EJ} = \frac{7}{12} \frac{b}{EJ}$$

$$L_{AD}^{xx} = \int_0^{2b} (1) \frac{1}{EJ} dx = \left[x \right]_0^{2b} \frac{1}{EJ}$$

$$= (2b) \frac{1}{EJ} = 2 \frac{b}{EJ}$$

$$L_{DA}^{xx} = \int_0^{2b} (1) \frac{1}{EJ} dx = \left[x \right]_0^{2b} \frac{1}{EJ}$$

$$= (2b) \frac{1}{EJ} = 2 \frac{b}{EJ}$$

$$L_{DE}^{xx} = \int_0^b (1 - 2x/b + x^2/b^2) \frac{1}{EJ} dx = \left[x - \frac{x^2}{b} + \frac{1}{3} \frac{x^3}{b^2} \right]_0^b \frac{1}{EJ}$$

$$= (b - b + \frac{1}{3}b) \frac{1}{EJ} = \frac{1}{3} \frac{b}{EJ}$$

$$L_{ED}^{xx} = \int_0^b (x^2/b^2) \frac{1}{EJ} dx = \left[\frac{1}{3} \frac{x^3}{b^2} \right]_0^b \frac{1}{EJ}$$

$$= (\frac{1}{3}b) \frac{1}{EJ} = \frac{1}{3} \frac{b}{EJ}$$

$$L_{AB}^{xo} = \int_0^b (3/2 x/b - x^2/b^2 - 1/2 x^3/b^3) Fb \frac{1}{EJ} dx + 1 \cdot 0 \cdot \frac{1}{4} \frac{Fb^2}{EJ}$$

$$= \left[\frac{3}{4} \frac{x^2}{b} - \frac{1}{3} \frac{x^3}{b^2} - \frac{1}{8} \frac{x^4}{b^3} \right]_0^b Fb \frac{1}{EJ} + 1 \cdot 0 \cdot \frac{1}{4} \frac{Fb^2}{EJ}$$

$$= (\frac{3}{4}b - \frac{1}{3}b - \frac{1}{8}b) Fb \frac{1}{EJ} + 1 \cdot 0 \cdot \frac{1}{4} \frac{Fb^2}{EJ} = \frac{7}{24} \frac{Fb^2}{EJ}$$

$$L_{BA}^{xo} = \int_0^b (2x/b - 5/2 x^2/b^2 + 1/2 x^3/b^3) Fb \frac{1}{EJ} dx + 1 \cdot 0 \cdot \frac{1}{4} \frac{Fb^2}{EJ}$$

$$= \left[\frac{x^2}{b} - \frac{5}{6} \frac{x^3}{b^2} + \frac{1}{8} \frac{x^4}{b^3} \right]_0^b Fb \frac{1}{EJ} + 1 \cdot 0 \cdot \frac{1}{4} \frac{Fb^2}{EJ}$$

$$= (b - \frac{5}{6}b + \frac{1}{8}b) Fb \frac{1}{EJ} + 1 \cdot 0 \cdot \frac{1}{4} \frac{Fb^2}{EJ} = \frac{7}{24} \frac{Fb^2}{EJ}$$

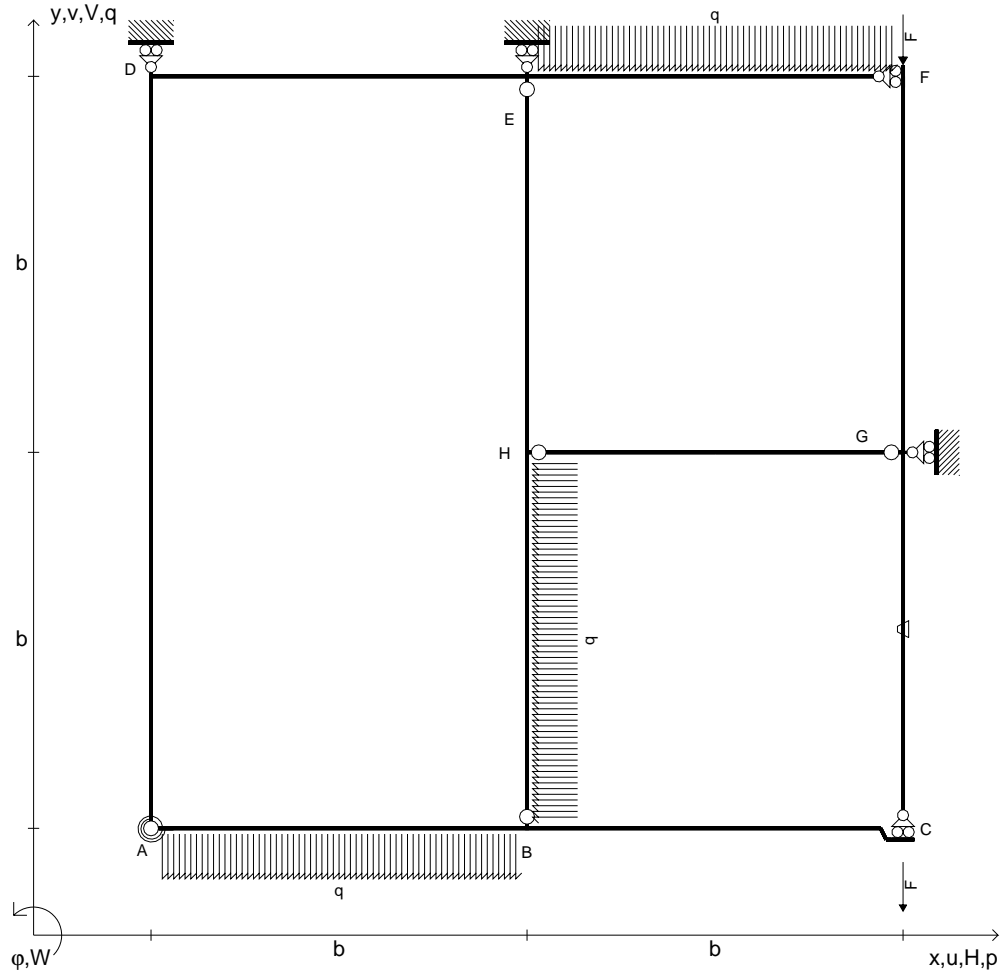

$V_{FG} = -F$	$k_{AB} = 4EJ/b$	$EJ_{FG} = EJ$
$V_{CB} = -F$	$EJ_{AB} = EJ$	$EJ_{GC} = EJ$
$q_{AB} = -q = -F/b$	$EJ_{BC} = EJ$	$EJ_{HG} = EJ$
$q_{EF} = -q = -F/b$	$EJ_{AD} = EJ$	$EJ_{HB} = EJ$
$p_{HB} = -q = -F/b$	$EJ_{DE} = EJ$	$EJ_{HE} = EJ$
$\theta_{GC} = -\theta = -\alpha T/b = -bF/EJ$	$EJ_{EF} = EJ$	

Reazioni iperstatiche in soluzione: $X=W_{DE}$
 Carichi e deformazioni date hanno verso efficace in disegno.
 Calcolare reazioni vincolari della struttura e delle aste.
 Tracciare i diagrammi quotati delle azioni interne nelle aste.
 $J_{YZ} - x_{YZ} - \theta_{YZ}$ riferimento locale asta YZ con origine in Y.
 Curvatura θ asta GC positiva se convessa a destra con inizio G.
 © Adolfo Zavelani Rossi, Politecnico di Milano, vers.27.03.13

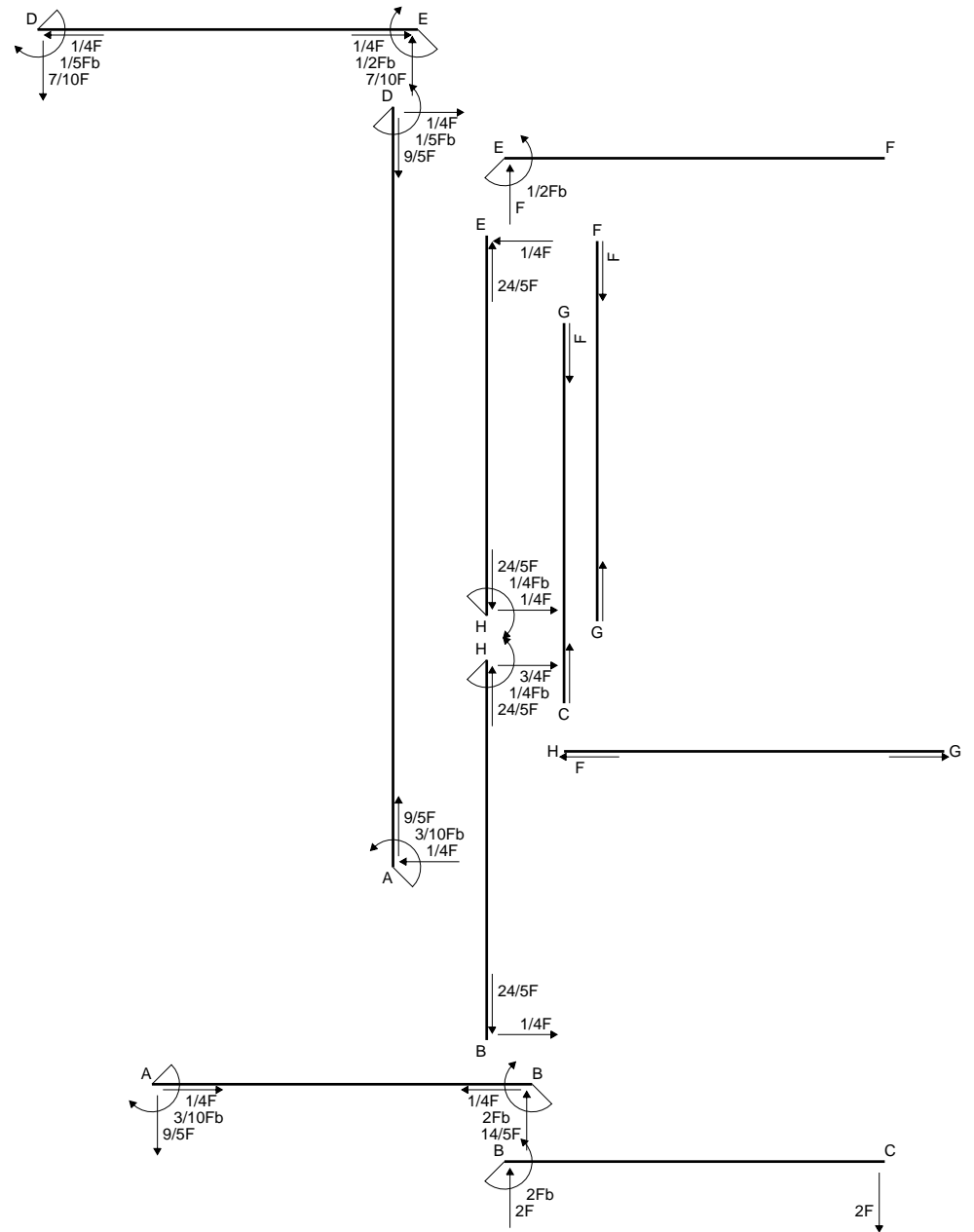

Quadro contributi PLV per iperstatica $X=W_{DE}$

→	$M_x(x)$	$M_o(x)$	θ	$M_x M_o$	$M_x \theta$	$M_x M_x$	$\int M_x(M_o/EJ+\theta)dx$	$\int X M_x M_x/EJ dx$	
AB b	$1-x/b$	$1/2Fb-2Fx-1/2qx^2$	0	$1/2Fb-5/2Fx+3/2Fx^2/b+1/2qx^3/b$	0	$1-2x/b+x^2/b^2$	$(-1/8+0)Fb^2/EJ$	$1/3Xb/EJ$	
BA b	$-x/b$	$2Fb-3Fx+1/2qx^2$	0	$-2Fx+3Fx^2/b-1/2qx^3/b$	0	x^2/b^2			
BC b	0	$-2Fb+2Fx$	0	0	0	0	0+0	0	
CB b	0	$2Fx$	0	0	0	0			
AD 2b	-1	$-1/2Fb+1/4Fx$	0	$1/2Fb-1/4Fx$	0	1	$(1/2+0)Fb^2/EJ$	$2Xb/EJ$	
DA 2b	1	$1/4Fx$	0	$1/4Fx$	0	1			
DE b	$-1+x/b$	$-1/2Fx$	0	$1/2Fx-1/2Fx^2/b$	0	$1-2x/b+x^2/b^2$	$(1/12+0)Fb^2/EJ$	$1/3Xb/EJ$	
ED b	x/b	$1/2Fb-1/2Fx$	0	$1/2Fx-1/2Fx^2/b$	0	x^2/b^2			
EF b	0	$-1/2Fb+Fx-1/2qx^2$	0	0	0	0	0+0	0	
FE b	0	$1/2qx^2$	0	0	0	0			
FG b	0	0	0	0	0	0	0+0	0	
GF b	0	0	0	0	0	0			
GC b	0	0	$-Fb/EJ$	0	0	0	0+0	0	
CG b	0	0	Fb/EJ	0	0	0			
HG b	0	0	0	0	0	0	0+0	0	
GH b	0	0	0	0	0	0			
HB b	0	$-1/4Fb+3/4Fx-1/2qx^2$	0	0	0	0	0+0	0	
BH b	0	$-1/4Fx+1/2qx^2$	0	0	0	0			
HE b	0	$1/4Fb-1/4Fx$	0	0	0	0	0+0	0	
EH b	0	$-1/4Fx$	0	0	0	0			
AB	molla asta $-W_{1AB}(W_{0AB}+XW_{1AB})/k_{AB}$							$1/8Fb^2/EJ$	$1/4Xb/EJ$
	totali							$7/12Fb^2/EJ$	$35/12Xb/EJ$
	iperstatica $X=W_{DE}$							$-1/5Fb$	

Sviluppi di calcolo iperstatica

$$L_{AB}^{xx} = \int_0^b (1 - 2x/b + x^2/b^2) \cdot 1/EJ \, dx - 1 \cdot (-1) \cdot 1/4 \cdot b/EJ = \left[x - x^2/b + 1/3 x^3/b^2 \right]_0^b \cdot 1/EJ - 1 \cdot (-1) \cdot 1/4 \cdot b/EJ$$

$$= (b - b + 1/3 b) \cdot 1/EJ - 1 \cdot (-1) \cdot 1/4 \cdot b/EJ = 7/12 \cdot b/EJ$$

$$L_{BA}^{xx} = \int_0^b (x^2/b^2) \cdot 1/EJ \, dx - 1 \cdot (-1) \cdot 1/4 \cdot b/EJ = \left[1/3 x^3/b^2 \right]_0^b \cdot 1/EJ - 1 \cdot (-1) \cdot 1/4 \cdot b/EJ$$

$$= (1/3 b) \cdot 1/EJ - 1 \cdot (-1) \cdot 1/4 \cdot b/EJ = 7/12 \cdot b/EJ$$

$$L_{AD}^{xx} = \int_0^{2b} (1) \cdot 1/EJ \, dx = \left[x \right]_0^{2b} \cdot 1/EJ$$

$$= (2b) \cdot 1/EJ = 2 \cdot b/EJ$$

$$L_{DA}^{xx} = \int_0^{2b} (1) \cdot 1/EJ \, dx = \left[x \right]_0^{2b} \cdot 1/EJ$$

$$= (2b) \cdot 1/EJ = 2 \cdot b/EJ$$

$$L_{DE}^{xx} = \int_0^b (1 - 2x/b + x^2/b^2) \cdot 1/EJ \, dx = \left[x - x^2/b + 1/3 x^3/b^2 \right]_0^b \cdot 1/EJ$$

$$= (b - b + 1/3 b) \cdot 1/EJ = 1/3 \cdot b/EJ$$

$$L_{ED}^{xx} = \int_0^b (x^2/b^2) \cdot 1/EJ \, dx = \left[1/3 x^3/b^2 \right]_0^b \cdot 1/EJ$$

$$= (1/3 b) \cdot 1/EJ = 1/3 \cdot b/EJ$$

$$L_{AB}^{xo} = \int_0^b (1/2 - 5/2 x/b + 3/2 x^2/b^2 + 1/2 x^3/b^3) \cdot Fb \cdot 1/EJ \, dx - 1 \cdot (-1/2) \cdot 1/4 \cdot Fb^2/EJ$$

$$= \left[1/2 x - 5/4 x^2/b + 1/2 x^3/b^2 + 1/8 x^4/b^3 \right]_0^b \cdot Fb \cdot 1/EJ - 1 \cdot (-1/2) \cdot 1/4 \cdot Fb^2/EJ$$

$$= (1/2 b - 5/4 b + 1/2 b + 1/8 b) \cdot Fb \cdot 1/EJ - 1 \cdot (-1/2) \cdot 1/4 \cdot Fb^2/EJ = 0$$

$$L_{BA}^{xo} = \int_0^b (-2x/b + 3x^2/b^2 - 1/2 x^3/b^3) \cdot Fb \cdot 1/EJ \, dx - 1 \cdot (-1/2) \cdot 1/4 \cdot Fb^2/EJ$$

$$= \left[-x^2/b + x^3/b^2 - 1/8 x^4/b^3 \right]_0^b \cdot Fb \cdot 1/EJ - 1 \cdot (-1/2) \cdot 1/4 \cdot Fb^2/EJ$$

$$= (-b + b - 1/8 b) \cdot Fb \cdot 1/EJ - 1 \cdot (-1/2) \cdot 1/4 \cdot Fb^2/EJ = 0$$

$$L_{AD}^{xo} = \int_0^{2b} (1/2 - 1/4 x/b) \cdot Fb \cdot 1/EJ \, dx = \left[1/2 x - 1/8 x^2/b \right]_0^{2b} \cdot Fb \cdot 1/EJ$$

$$= (b - 1/2 b) \cdot Fb \cdot 1/EJ = 1/2 \cdot Fb^2/EJ$$

$$L_{DA}^{xo} = \int_0^{2b} (1/4 x/b) \cdot Fb \cdot 1/EJ \, dx = \left[1/8 x^2/b \right]_0^{2b} \cdot Fb \cdot 1/EJ$$

$$= (1/2 b) \cdot Fb \cdot 1/EJ = 1/2 \cdot Fb^2/EJ$$

$$L_{DE}^{xo} = \int_0^b (1/2 x/b - 1/2 x^2/b^2) \cdot Fb \cdot 1/EJ \, dx = \left[1/4 x^2/b - 1/6 x^3/b^2 \right]_0^b \cdot Fb \cdot 1/EJ$$

$$= (1/4 b - 1/6 b) \cdot Fb \cdot 1/EJ = 1/12 \cdot Fb^2/EJ$$

$$L_{ED}^{xo} = \int_0^b (1/2 x/b - 1/2 x^2/b^2) \cdot Fb \cdot 1/EJ \, dx = \left[1/4 x^2/b - 1/6 x^3/b^2 \right]_0^b \cdot Fb \cdot 1/EJ$$

$$= (1/4 b - 1/6 b) \cdot Fb \cdot 1/EJ = 1/12 \cdot Fb^2/EJ$$

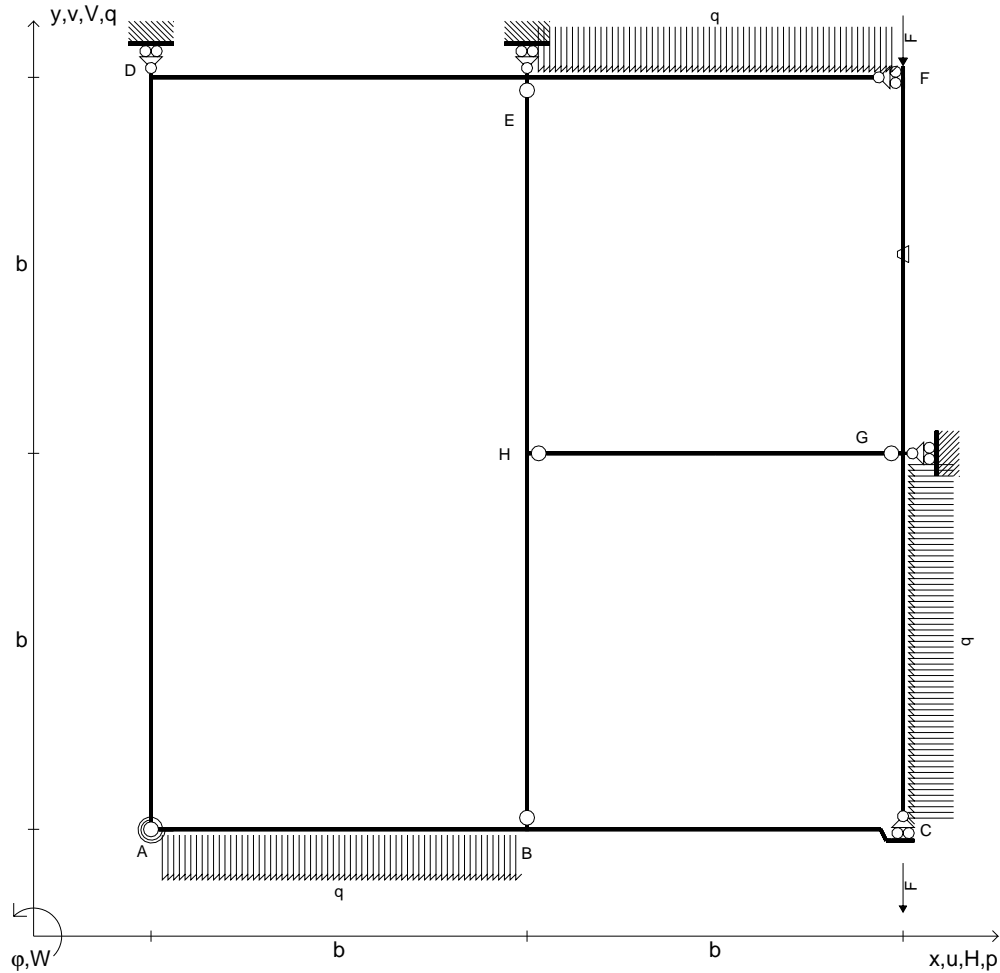

$V_{FG} = -F$	$k_{AB} = 4EJ/b$	$EJ_{FG} = EJ$
$V_{CB} = -F$	$EJ_{AB} = EJ$	$EJ_{GC} = EJ$
$q_{AB} = -q = -F/b$	$EJ_{BC} = EJ$	$EJ_{HG} = EJ$
$q_{EF} = -q = -F/b$	$EJ_{AD} = EJ$	$EJ_{HB} = EJ$
$p_{GC} = -q = -F/b$	$EJ_{DE} = EJ$	$EJ_{HE} = EJ$
$\theta_{FG} = -\theta = -\alpha T/b = -bF/EJ$	$EJ_{EF} = EJ$	

Reazioni iperstatiche in soluzione: $X=W_{AD}$

Carichi e deformazioni date hanno verso efficace in disegno.

Calcolare reazioni vincolari della struttura e delle aste.

Tracciare i diagrammi quotati delle azioni interne nelle aste.

$J_{YZ} - x_{YZ} - \theta_{YZ}$ riferimento locale asta YZ con origine in Y.

Curvatura θ asta FG positiva se convessa a destra con inizio F.

@ Adolfo Zavelani Rossi, Politecnico di Milano, vers.27.03.13

08.01.25

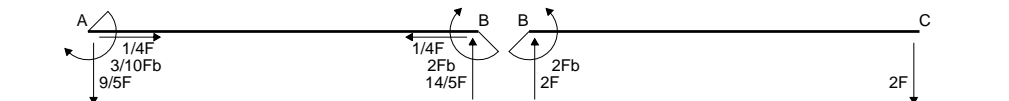
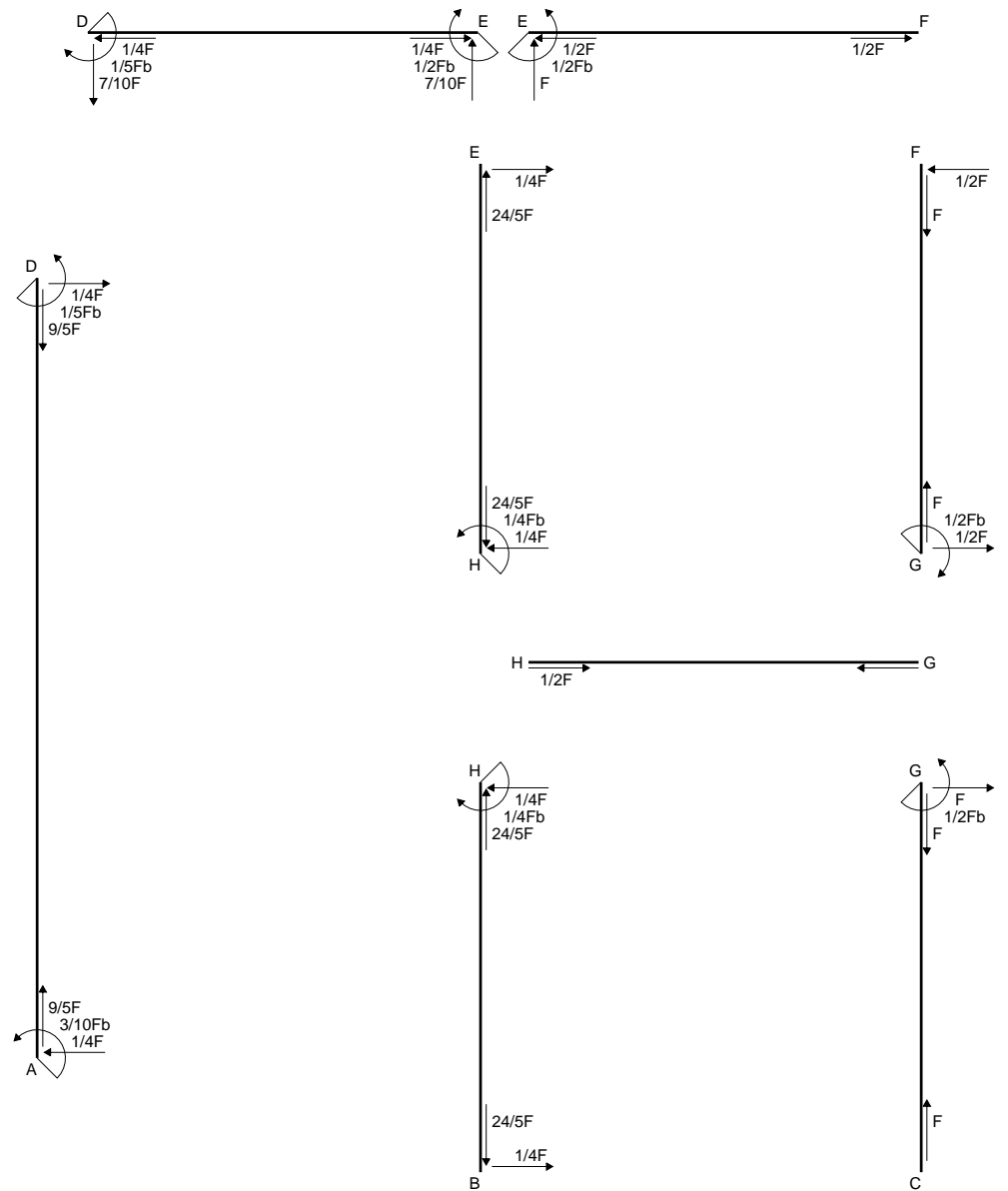

@ Adolfo Zavelani Rossi, Politecnico di Milano, vers.27.03.13

08.01.25

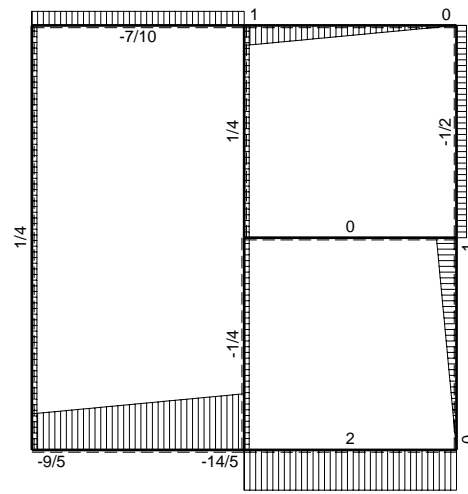
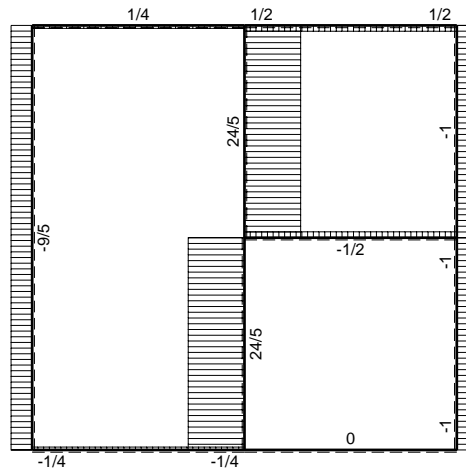

← (+) → F

↑ (+) ↓ F

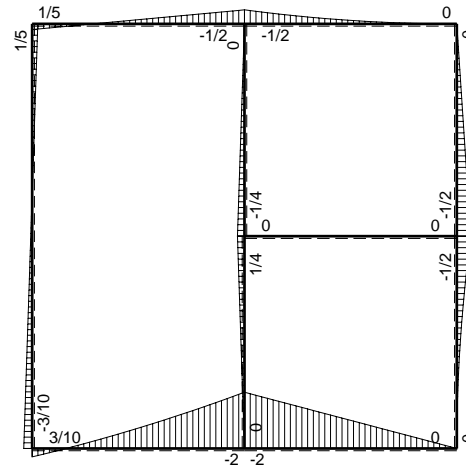

⊙ (+) ⊙ F_b

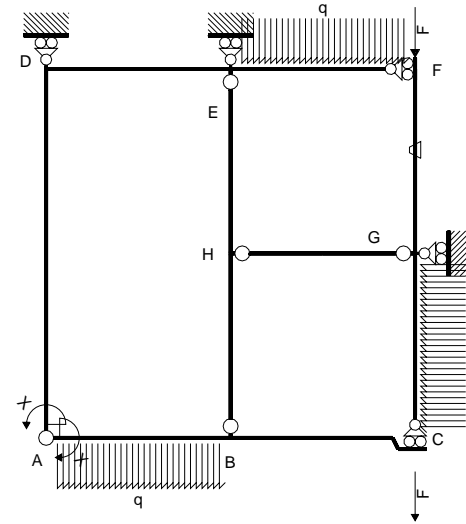

Schema di calcolo iperstatico

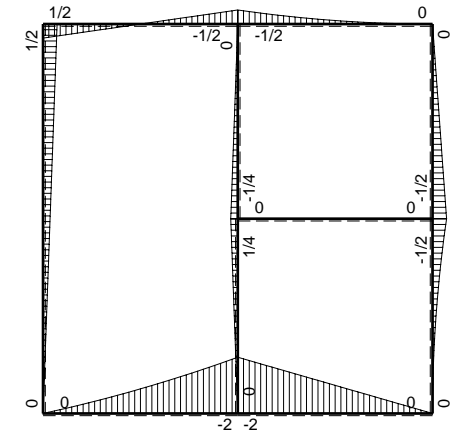

⊙ (+) ⊙ M_o flessione da carichi assegnati

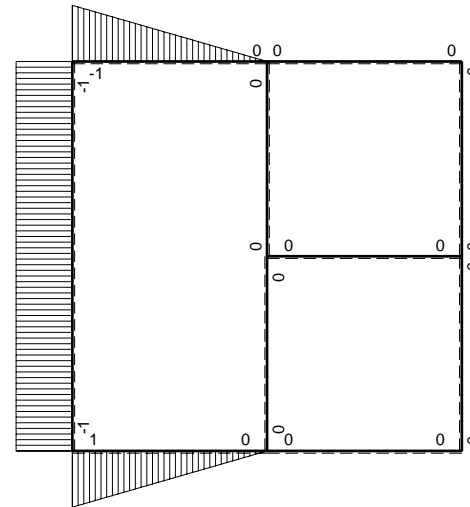

⊙ (+) ⊙ M_x flessione da iperstatica X=1

Quadro contributi PLV per iperstatica $X=W_{AD}$

→	$M_x(x)$	$M_o(x)$	θ	$M_x M_o$	$M_x \theta$	$M_x M_x$	$\int M_x(M_o/EJ+\theta)dx$	$\int X M_x M_x/EJdx$
AB b	$1-x/b$	$-3/2Fx-1/2qx^2$	0	$-3/2Fx+Fx^2/b+1/2qx^3/b$	0	$1-2x/b+x^2/b^2$	$(-7/24+0)Fb^2/EJ$	$1/3Xb/EJ$
BA b	$-x/b$	$2Fb-5/2Fx+1/2qx^2$	0	$-2Fx+5/2Fx^2/b-1/2qx^3/b$	0	x^2/b^2		
BC b	0	$-2Fb+2Fx$	0	0	0	0	0+0	0
CB b	0	$2Fx$	0	0	0	0		
AD 2b	-1	$1/4Fx$	0	$-1/4Fx$	0	1	$(-1/2+0)Fb^2/EJ$	$2Xb/EJ$
DA 2b	1	$-1/2Fb+1/4Fx$	0	$-1/2Fb+1/4Fx$	0	1		
DE b	$-1+x/b$	$1/2Fb-Fx$	0	$-1/2Fb+3/2Fx-Fx^2/b$	0	$1-2x/b+x^2/b^2$	$(-1/12+0)Fb^2/EJ$	$1/3Xb/EJ$
ED b	x/b	$1/2Fb-Fx$	0	$1/2Fx-Fx^2/b$	0	x^2/b^2		
EF b	0	$-1/2Fb+Fx-1/2qx^2$	0	0	0	0	0+0	0
FE b	0	$1/2qx^2$	0	0	0	0		
FG b	0	$-1/2Fx$	$-Fb/EJ$	0	0	0	0+0	0
GF b	0	$1/2Fb-1/2Fx$	Fb/EJ	0	0	0		
GC b	0	$-1/2Fb+Fx-1/2qx^2$	0	0	0	0	0+0	0
CG b	0	$1/2qx^2$	0	0	0	0		
HG b	0	0	0	0	0	0	0+0	0
GH b	0	0	0	0	0	0		
HB b	0	$1/4Fb-1/4Fx$	0	0	0	0	0+0	0
BH b	0	$-1/4Fx$	0	0	0	0		
HE b	0	$-1/4Fb+1/4Fx$	0	0	0	0	0+0	0
EH b	0	$1/4Fx$	0	0	0	0		
AB	molla asta $-W_{1AB}(W_{0AB}+XW_{1AB})/k_{AB}$							$1/4Xb/EJ$
	totali						$-7/8Fb^2/EJ$	$35/12Xb/EJ$
	iperstatica $X=W_{AD}$						$3/10Fb$	

Sviluppi di calcolo iperstatica

$$L_{AB}^{xx} = \int_0^b (1 - 2x/b + x^2/b^2) \cdot 1/EJ \, dx - 1 \cdot (-1) \cdot 1/4 \cdot b/EJ = \left[x - x^2/b + 1/3 x^3/b^2 \right]_0^b \cdot 1/EJ - 1 \cdot (-1) \cdot 1/4 \cdot b/EJ$$

$$= (b - b + 1/3 b) \cdot 1/EJ - 1 \cdot (-1) \cdot 1/4 \cdot b/EJ = 7/12 \cdot b/EJ$$

$$L_{BA}^{xx} = \int_0^b (x^2/b^2) \cdot 1/EJ \, dx - 1 \cdot (-1) \cdot 1/4 \cdot b/EJ = \left[1/3 x^3/b^2 \right]_0^b \cdot 1/EJ - 1 \cdot (-1) \cdot 1/4 \cdot b/EJ$$

$$= (1/3 b) \cdot 1/EJ - 1 \cdot (-1) \cdot 1/4 \cdot b/EJ = 7/12 \cdot b/EJ$$

$$L_{AD}^{xx} = \int_0^{2b} (1) \cdot 1/EJ \, dx = \left[x \right]_0^{2b} \cdot 1/EJ$$

$$= (2b) \cdot 1/EJ = 2 \cdot b/EJ$$

$$L_{DA}^{xx} = \int_0^{2b} (1) \cdot 1/EJ \, dx = \left[x \right]_0^{2b} \cdot 1/EJ$$

$$= (2b) \cdot 1/EJ = 2 \cdot b/EJ$$

$$L_{DE}^{xx} = \int_0^b (1 - 2x/b + x^2/b^2) \cdot 1/EJ \, dx = \left[x - x^2/b + 1/3 x^3/b^2 \right]_0^b \cdot 1/EJ$$

$$= (b - b + 1/3 b) \cdot 1/EJ = 1/3 \cdot b/EJ$$

$$L_{ED}^{xx} = \int_0^b (x^2/b^2) \cdot 1/EJ \, dx = \left[1/3 x^3/b^2 \right]_0^b \cdot 1/EJ$$

$$= (1/3 b) \cdot 1/EJ = 1/3 \cdot b/EJ$$

$$L_{AB}^{xo} = \int_0^b (-3/2 x/b + x^2/b^2 + 1/2 x^3/b^3) \cdot Fb \cdot 1/EJ \, dx - 1 \cdot 0 \cdot 1/4 \cdot Fb^2/EJ$$

$$= \left[-3/4 x^2/b + 1/3 x^3/b^2 + 1/8 x^4/b^3 \right]_0^b \cdot Fb \cdot 1/EJ - 1 \cdot 0 \cdot 1/4 \cdot Fb^2/EJ$$

$$= (-3/4 b + 1/3 b + 1/8 b) \cdot Fb \cdot 1/EJ - 1 \cdot 0 \cdot 1/4 \cdot Fb^2/EJ = -7/24 \cdot Fb^2/EJ$$

$$L_{BA}^{xo} = \int_0^b (-2x/b + 5/2 x^2/b^2 - 1/2 x^3/b^3) \cdot Fb \cdot 1/EJ \, dx - 1 \cdot 0 \cdot 1/4 \cdot Fb^2/EJ$$

$$= \left[-x^2/b + 5/6 x^3/b^2 - 1/8 x^4/b^3 \right]_0^b \cdot Fb \cdot 1/EJ - 1 \cdot 0 \cdot 1/4 \cdot Fb^2/EJ$$

$$= (-b + 5/6 b - 1/8 b) \cdot Fb \cdot 1/EJ - 1 \cdot 0 \cdot 1/4 \cdot Fb^2/EJ = -7/24 \cdot Fb^2/EJ$$

$$L_{AD}^{xo} = \int_0^{2b} (-1/4 x/b) \cdot Fb \cdot 1/EJ \, dx = \left[-1/8 x^2/b \right]_0^{2b} \cdot Fb \cdot 1/EJ$$

$$= (-1/2 b) \cdot Fb \cdot 1/EJ = -1/2 \cdot Fb^2/EJ$$

$$L_{DA}^{xo} = \int_0^{2b} (-1/2 + 1/4 x/b) \cdot Fb \cdot 1/EJ \, dx = \left[-1/2 x + 1/8 x^2/b \right]_0^{2b} \cdot Fb \cdot 1/EJ$$

$$= (-b + 1/2 b) \cdot Fb \cdot 1/EJ = -1/2 \cdot Fb^2/EJ$$

$$L_{DE}^{xo} = \int_0^b (-1/2 + 3/2 x/b - x^2/b^2) \cdot Fb \cdot 1/EJ \, dx = \left[-1/2 x + 3/4 x^2/b - 1/3 x^3/b^2 \right]_0^b \cdot Fb \cdot 1/EJ$$

$$= (-1/2 b + 3/4 b - 1/3 b) \cdot Fb \cdot 1/EJ = -1/12 \cdot Fb^2/EJ$$

$$L_{ED}^{xo} = \int_0^b (1/2 x/b - x^2/b^2) \cdot Fb \cdot 1/EJ \, dx = \left[1/4 x^2/b - 1/3 x^3/b^2 \right]_0^b \cdot Fb \cdot 1/EJ$$

$$= (1/4 b - 1/3 b) \cdot Fb \cdot 1/EJ = -1/12 \cdot Fb^2/EJ$$

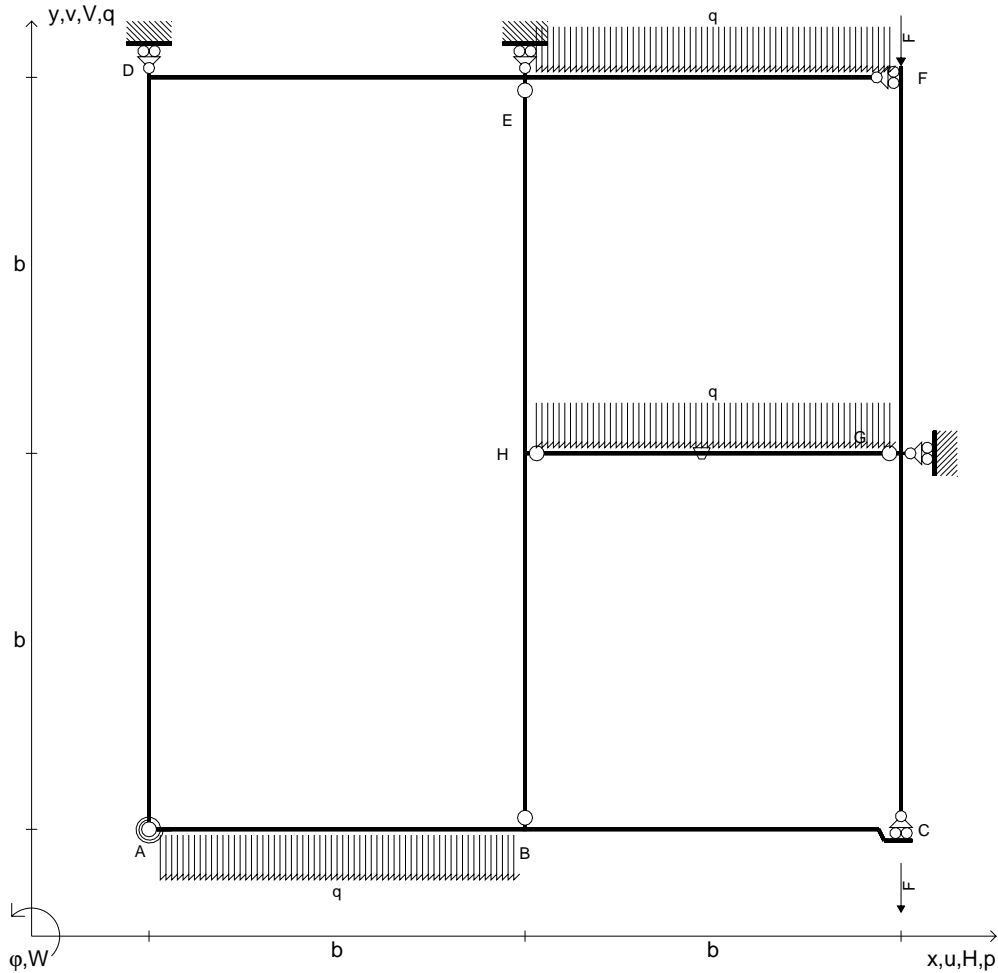

$V_{FG} = -F$	$k_{AB} = 4EJ/b$	$EJ_{FG} = EJ$
$V_{CB} = -F$	$EJ_{AB} = EJ$	$EJ_{GC} = EJ$
$q_{AB} = -q = -F/b$	$EJ_{BC} = EJ$	$EJ_{HG} = EJ$
$q_{EF} = -q = -F/b$	$EJ_{AD} = EJ$	$EJ_{HB} = EJ$
$q_{HG} = -q = -F/b$	$EJ_{DE} = EJ$	$EJ_{HE} = EJ$
$\theta_{HG} = -\theta = -\alpha T/b = -bF/EJ$	$EJ_{EF} = EJ$	

Reazioni iperstatiche in soluzione: $X=W_{DE}$

Carichi e deformazioni date hanno verso efficace in disegno.

Calcolare reazioni vincolari della struttura e delle aste.

Tracciare i diagrammi quotati delle azioni interne nelle aste.

$J_{YZ} - x_{YZ} - \theta_{YZ}$ riferimento locale asta YZ con origine in Y.

Curvatura θ asta HG positiva se convessa a destra con inizio H.

@ Adolfo Zavelani Rossi, Politecnico di Milano, vers.27.03.13

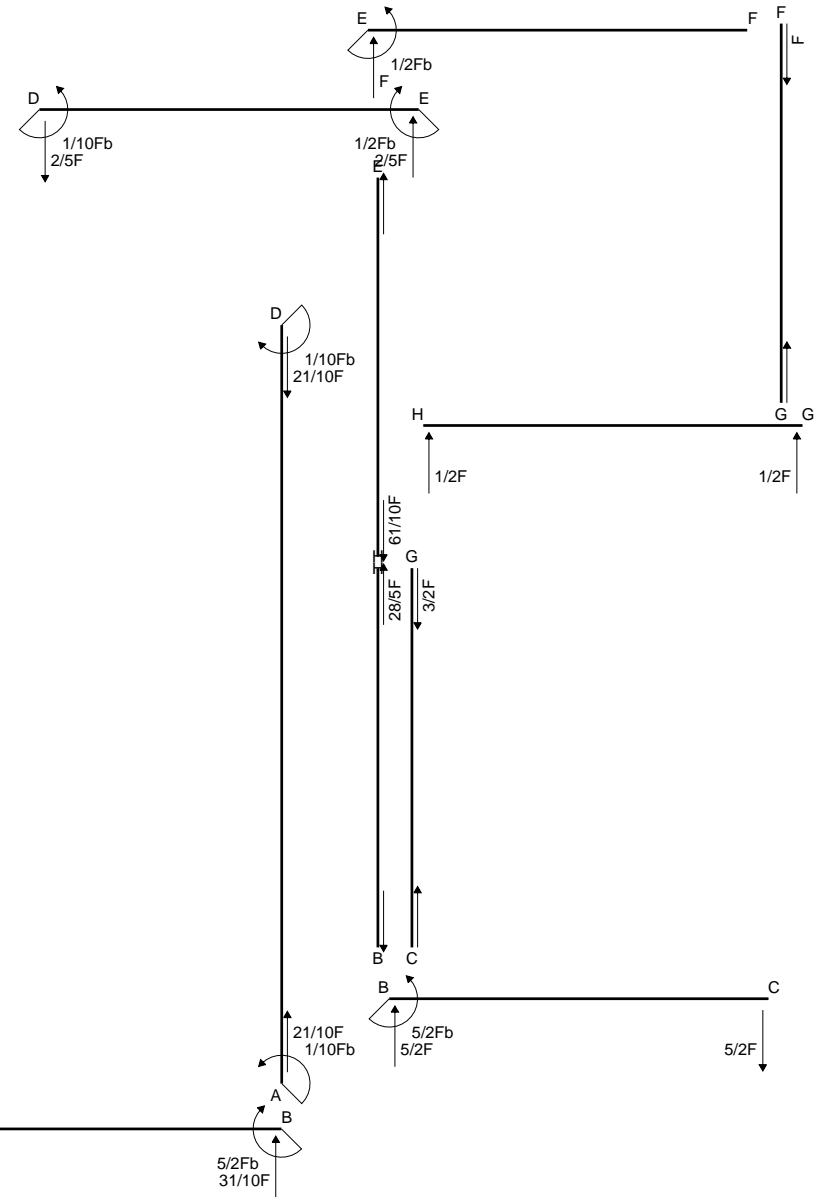

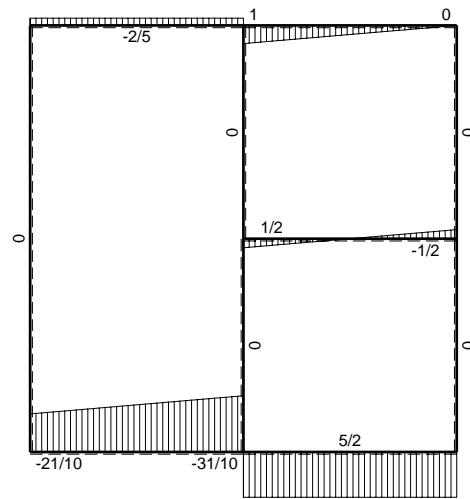
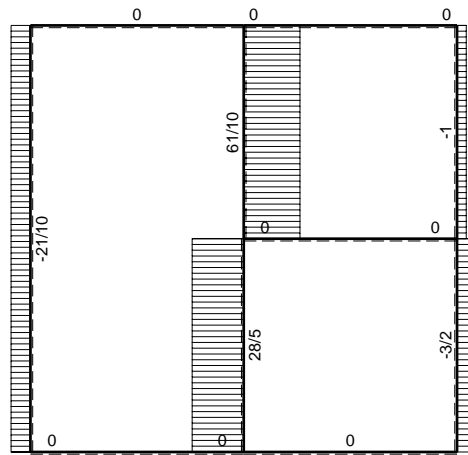

← (+) → F

↑ (+) ↓ F

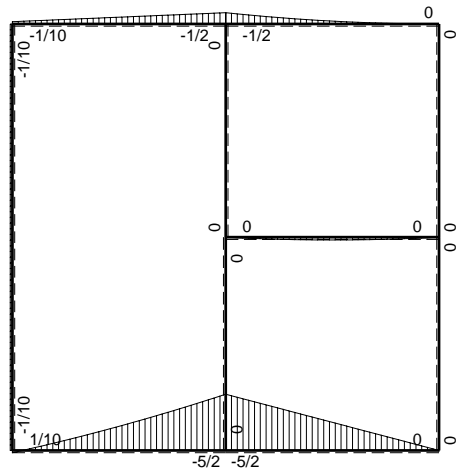

⊕ F_b

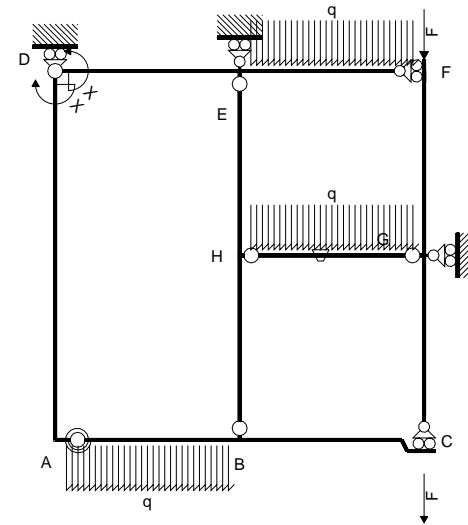

Schema di calcolo iperstatico

⊕ M₀ flessione da carichi assegnati

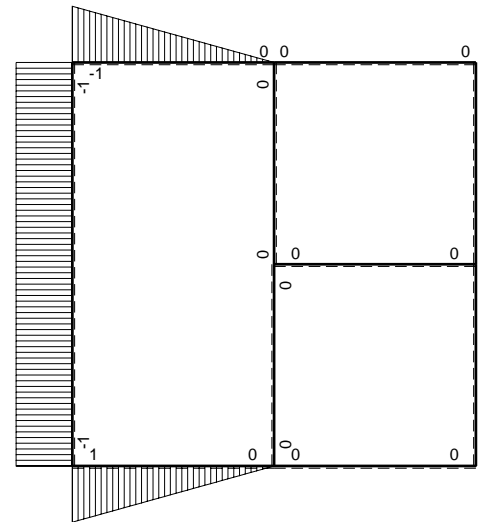

⊕ M_x flessione da iperstatica X=1

Quadro contributi PLV per iperstatica $X=W_{DE}$

→	$M_x(x)$	$M_o(x)$	θ	$M_x M_o$	$M_x \theta$	$M_x M_x$	$\int M_x(M_o/EJ+\theta)dx$	$\int X M_x M_x/EJ dx$	
AB b	$1-x/b$	$-2Fx-1/2qx^2$	0	$-2Fx+3/2Fx^2/b+1/2qx^3/b$	0	$1-2x/b+x^2/b^2$	$(-3/8+0)Fb^2/EJ$	$1/3Xb/EJ$	
BA b	$-x/b$	$5/2Fb-3Fx+1/2qx^2$	0	$-5/2Fx+3Fx^2/b-1/2qx^3/b$	0	x^2/b^2			
BC b	0	$-5/2Fb+5/2Fx$	0	0	0	0	0+0	0	
CB b	0	$5/2Fx$	0	0	0	0			
AD 2b	-1	0	0	0	0	1	0+0	$2Xb/EJ$	
DA 2b	1	0	0	0	0	1			
DE b	$-1+x/b$	$-1/2Fx$	0	$1/2Fx-1/2Fx^2/b$	0	$1-2x/b+x^2/b^2$	$(1/12+0)Fb^2/EJ$	$1/3Xb/EJ$	
ED b	x/b	$1/2Fb-1/2Fx$	0	$1/2Fx-1/2Fx^2/b$	0	x^2/b^2			
EF b	0	$-1/2Fb+Fx-1/2qx^2$	0	0	0	0	0+0	0	
FE b	0	$1/2qx^2$	0	0	0	0			
FG b	0	0	0	0	0	0	0+0	0	
GF b	0	0	0	0	0	0			
GC b	0	0	0	0	0	0	0+0	0	
CG b	0	0	0	0	0	0			
HG b	0	$1/2Fx-1/2qx^2$	$-Fb/EJ$	0	0	0	0+0	0	
GH b	0	$-1/2Fx+1/2qx^2$	Fb/EJ	0	0	0			
HB b	0	0	0	0	0	0	0+0	0	
BH b	0	0	0	0	0	0			
HE b	0	0	0	0	0	0	0+0	0	
EH b	0	0	0	0	0	0			
AB	molla asta $-W_{1AB}(W_{0AB}+XW_{1AB})/k_{AB}$								$1/4Xb/EJ$
	totali							$-7/24Fb^2/EJ$	$35/12Xb/EJ$
	iperstatica $X=W_{DE}$							$1/10Fb$	

Sviluppi di calcolo iperstatica

$$L_{AB}^{xx} = \int_0^b (1 - 2x/b + x^2/b^2) \cdot 1/EJ \, dx - 1 \cdot (-1) \cdot 1/4 \cdot b/EJ = \left[x - x^2/b + 1/3 x^3/b^2 \right]_0^b \cdot 1/EJ - 1 \cdot (-1) \cdot 1/4 \cdot b/EJ$$

$$= (b - b + 1/3 b) \cdot 1/EJ - 1 \cdot (-1) \cdot 1/4 \cdot b/EJ = 7/12 \cdot b/EJ$$

$$L_{BA}^{xx} = \int_0^b (x^2/b^2) \cdot 1/EJ \, dx - 1 \cdot (-1) \cdot 1/4 \cdot b/EJ = \left[1/3 x^3/b^2 \right]_0^b \cdot 1/EJ - 1 \cdot (-1) \cdot 1/4 \cdot b/EJ$$

$$= (1/3 b) \cdot 1/EJ - 1 \cdot (-1) \cdot 1/4 \cdot b/EJ = 7/12 \cdot b/EJ$$

$$L_{AD}^{xx} = \int_0^{2b} (1) \cdot 1/EJ \, dx = \left[x \right]_0^{2b} \cdot 1/EJ$$

$$= (2b) \cdot 1/EJ = 2 \cdot b/EJ$$

$$L_{DA}^{xx} = \int_0^{2b} (1) \cdot 1/EJ \, dx = \left[x \right]_0^{2b} \cdot 1/EJ$$

$$= (2b) \cdot 1/EJ = 2 \cdot b/EJ$$

$$L_{DE}^{xx} = \int_0^b (1 - 2x/b + x^2/b^2) \cdot 1/EJ \, dx = \left[x - x^2/b + 1/3 x^3/b^2 \right]_0^b \cdot 1/EJ$$

$$= (b - b + 1/3 b) \cdot 1/EJ = 1/3 \cdot b/EJ$$

$$L_{ED}^{xx} = \int_0^b (x^2/b^2) \cdot 1/EJ \, dx = \left[1/3 x^3/b^2 \right]_0^b \cdot 1/EJ$$

$$= (1/3 b) \cdot 1/EJ = 1/3 \cdot b/EJ$$

$$L_{AB}^{xo} = \int_0^b (-2x/b + 3/2 x^2/b^2 + 1/2 x^3/b^3) \cdot Fb \cdot 1/EJ \, dx - 1 \cdot 0 \cdot 1/4 \cdot Fb^2/EJ$$

$$= \left[-x^2/b + 1/2 x^3/b^2 + 1/8 x^4/b^3 \right]_0^b \cdot Fb \cdot 1/EJ - 1 \cdot 0 \cdot 1/4 \cdot Fb^2/EJ$$

$$= (-b + 1/2 b + 1/8 b) \cdot Fb \cdot 1/EJ - 1 \cdot 0 \cdot 1/4 \cdot Fb^2/EJ = -3/8 \cdot Fb^2/EJ$$

$$L_{BA}^{xo} = \int_0^b (-5/2 x/b + 3 x^2/b^2 - 1/2 x^3/b^3) \cdot Fb \cdot 1/EJ \, dx - 1 \cdot 0 \cdot 1/4 \cdot Fb^2/EJ$$

$$= \left[-5/4 x^2/b + x^3/b^2 - 1/8 x^4/b^3 \right]_0^b \cdot Fb \cdot 1/EJ - 1 \cdot 0 \cdot 1/4 \cdot Fb^2/EJ$$

$$= (-5/4 b + b - 1/8 b) \cdot Fb \cdot 1/EJ - 1 \cdot 0 \cdot 1/4 \cdot Fb^2/EJ = -3/8 \cdot Fb^2/EJ$$

$$L_{DE}^{xo} = \int_0^b (1/2 x/b - 1/2 x^2/b^2) \cdot Fb \cdot 1/EJ \, dx = \left[1/4 x^2/b - 1/6 x^3/b^2 \right]_0^b \cdot Fb \cdot 1/EJ$$

$$= (1/4 b - 1/6 b) \cdot Fb \cdot 1/EJ = 1/12 \cdot Fb^2/EJ$$

$$L_{ED}^{xo} = \int_0^b (1/2 x/b - 1/2 x^2/b^2) \cdot Fb \cdot 1/EJ \, dx = \left[1/4 x^2/b - 1/6 x^3/b^2 \right]_0^b \cdot Fb \cdot 1/EJ$$

$$= (1/4 b - 1/6 b) \cdot Fb \cdot 1/EJ = 1/12 \cdot Fb^2/EJ$$

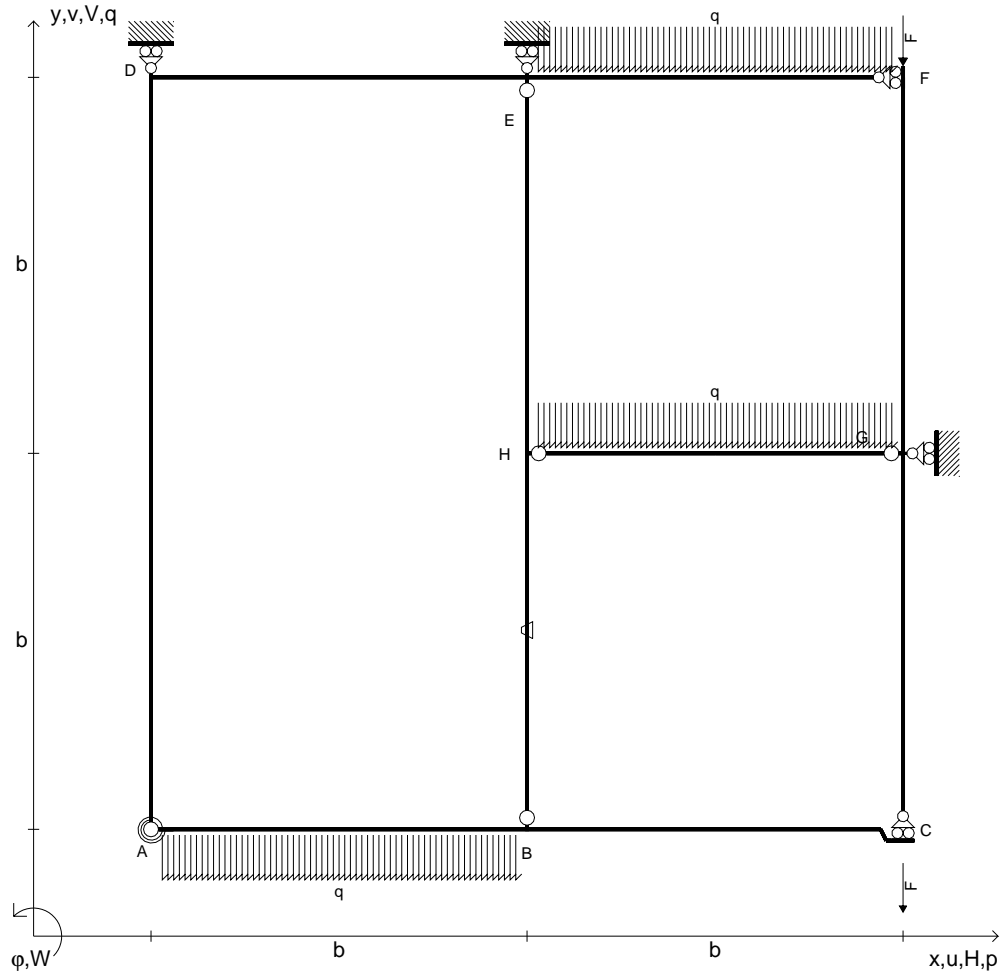

$V_{FG} = -F$	$k_{AB} = 4EJ/b$	$EJ_{FG} = EJ$
$V_{CB} = -F$	$EJ_{AB} = EJ$	$EJ_{GC} = EJ$
$q_{AB} = -q = -F/b$	$EJ_{BC} = EJ$	$EJ_{HG} = EJ$
$q_{EF} = -q = -F/b$	$EJ_{AD} = EJ$	$EJ_{HB} = EJ$
$q_{HG} = -q = -F/b$	$EJ_{DE} = EJ$	$EJ_{HE} = EJ$
$\theta_{HB} = -\theta = -\alpha T/b = -bF/EJ$	$EJ_{EF} = EJ$	

Reazioni iperstatiche in soluzione: $X=W_{AB}$

Carichi e deformazioni date hanno verso efficace in disegno.

Calcolare reazioni vincolari della struttura e delle aste.

Tracciare i diagrammi quotati delle azioni interne nelle aste.

$J_{YZ} - x_{YZ} - \theta_{YZ}$ riferimento locale asta YZ con origine in Y.

Curvatura θ asta HB positiva se convessa a destra con inizio H.

@ Adolfo Zavelani Rossi, Politecnico di Milano, vers.27.03.13

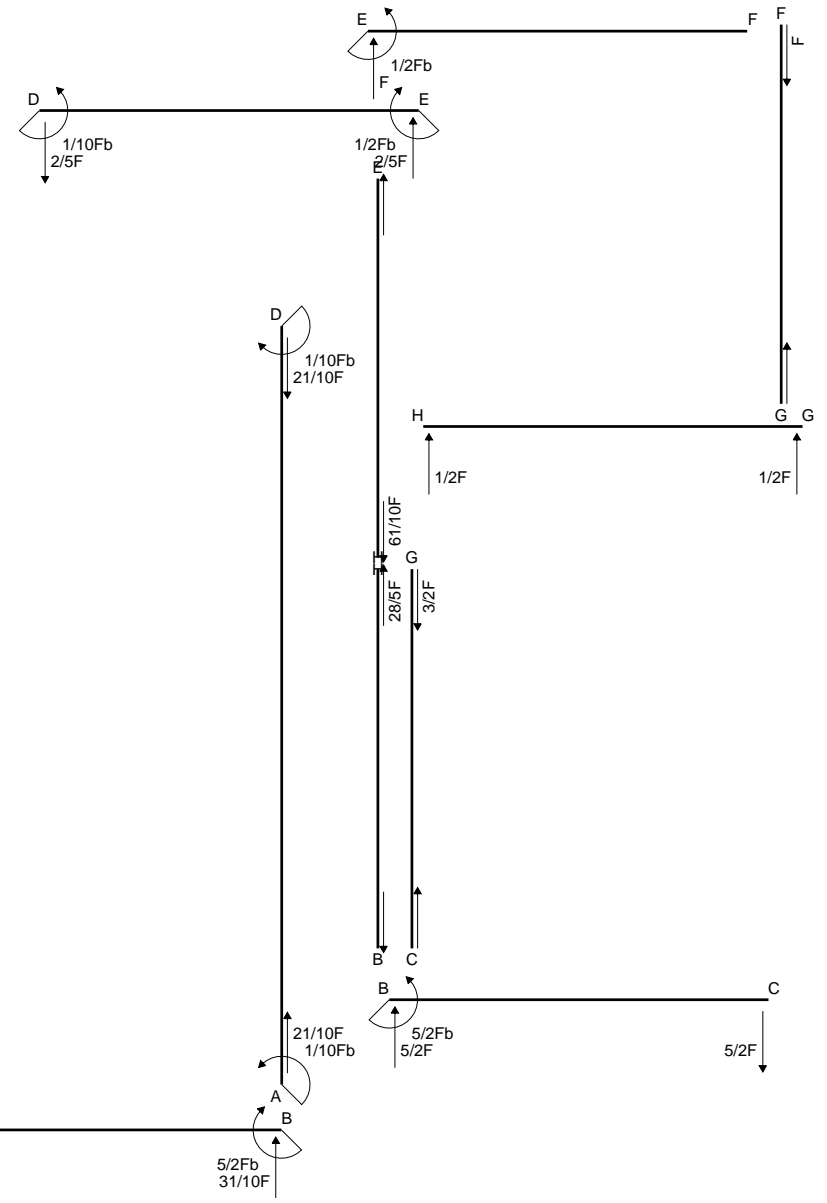

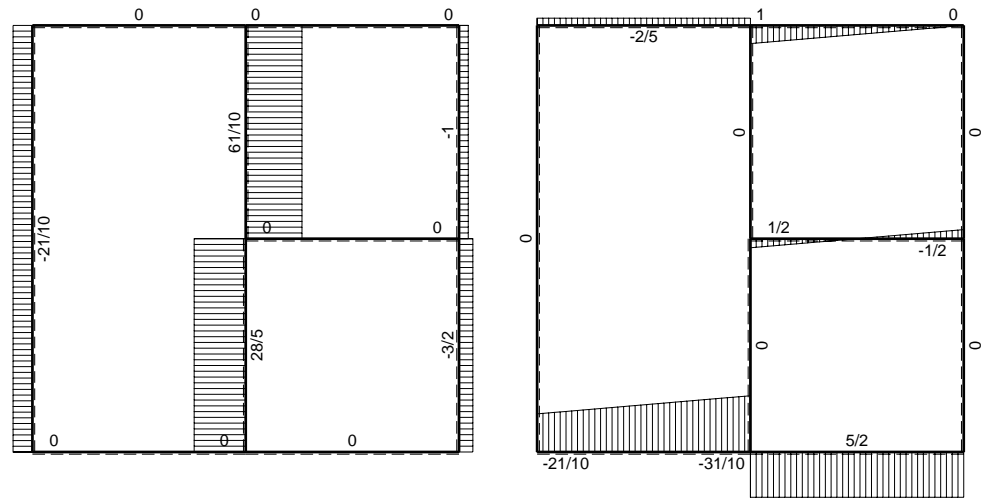

← (+) → F

↑ (+) ↓ F

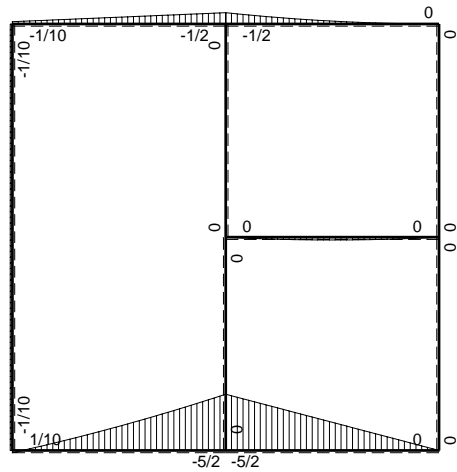

⌚ (+) ↻ Mb

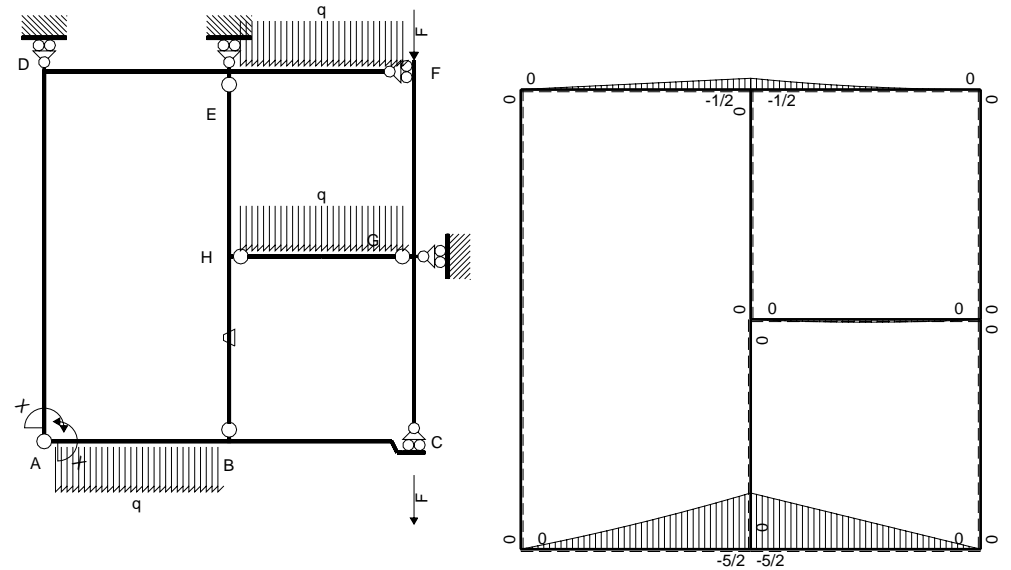

Schema di calcolo iperstatico

⌚ (+) ↻ Mo flessione da carichi assegnati

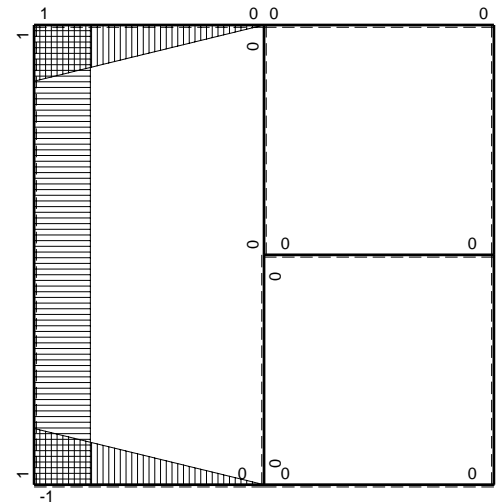

⌚ (+) ↻ Mx flessione da iperstatica X=1

Quadro contributi PLV per iperstatica $X=W_{AB}$

→	$M_x(x)$	$M_o(x)$	θ	$M_x M_o$	$M_x \theta$	$M_x M_x$	$\int M_x(M_o/EJ+\theta)dx$	$\int X M_x M_x/EJ dx$	
AB b	$-1+x/b$	$-2Fx-1/2qx^2$	0	$2Fx-3/2Fx^2/b-1/2qx^3/b$	0	$1-2x/b+x^2/b^2$	$(3/8+0)Fb^2/EJ$	$1/3Xb/EJ$	
BA b	x/b	$5/2Fb-3Fx+1/2qx^2$	0	$5/2Fx-3Fx^2/b+1/2qx^3/b$	0	x^2/b^2			
BC b	0	$-5/2Fb+5/2Fx$	0	0	0	0	0+0	0	
CB b	0	$5/2Fx$	0	0	0	0			
AD 2b	1	0	0	0	0	1	0+0	$2Xb/EJ$	
DA 2b	-1	0	0	0	0	1			
DE b	$1-x/b$	$-1/2Fx$	0	$-1/2Fx+1/2Fx^2/b$	0	$1-2x/b+x^2/b^2$	$(-1/12+0)Fb^2/EJ$	$1/3Xb/EJ$	
ED b	$-x/b$	$1/2Fb-1/2Fx$	0	$-1/2Fx+1/2Fx^2/b$	0	x^2/b^2			
EF b	0	$-1/2Fb+Fx-1/2qx^2$	0	0	0	0	0+0	0	
FE b	0	$1/2qx^2$	0	0	0	0			
FG b	0	0	0	0	0	0	0+0	0	
GF b	0	0	0	0	0	0			
GC b	0	0	0	0	0	0	0+0	0	
CG b	0	0	0	0	0	0			
HG b	0	$1/2Fx-1/2qx^2$	0	0	0	0	0+0	0	
GH b	0	$-1/2Fx+1/2qx^2$	0	0	0	0			
HB b	0	0	$-Fb/EJ$	0	0	0	0+0	0	
BH b	0	0	Fb/EJ	0	0	0			
HE b	0	0	0	0	0	0	0+0	0	
EH b	0	0	0	0	0	0			
AB	molla asta $-W_{1AB} (W_{0AB} + XW_{1AB})/k_{AB}$								$1/4Xb/EJ$
	totali							$7/24Fb^2/EJ$	$35/12Xb/EJ$
	iperstatica $X=W_{AB}$							$-1/10Fb$	

Sviluppi di calcolo iperstatica

$$L_{AB}^{xx} = \int_0^b (1 - 2x/b + x^2/b^2) \cdot 1/EJ \, dx + 1 \cdot 1/4 \cdot b/EJ = \left[x - x^2/b + 1/3 x^3/b^2 \right]_0^b \cdot 1/EJ + 1 \cdot 1/4 \cdot b/EJ$$

$$= (b - b + 1/3 b) \cdot 1/EJ + 1 \cdot 1/4 \cdot b/EJ = 7/12 \cdot b/EJ$$

$$L_{BA}^{xx} = \int_0^b (x^2/b^2) \cdot 1/EJ \, dx + 1 \cdot 1/4 \cdot b/EJ = \left[1/3 x^3/b^2 \right]_0^b \cdot 1/EJ + 1 \cdot 1/4 \cdot b/EJ$$

$$= (1/3 b) \cdot 1/EJ + 1 \cdot 1/4 \cdot b/EJ = 7/12 \cdot b/EJ$$

$$L_{AD}^{xx} = \int_0^{2b} (1) \cdot 1/EJ \, dx = \left[x \right]_0^{2b} \cdot 1/EJ$$

$$= (2b) \cdot 1/EJ = 2 \cdot b/EJ$$

$$L_{DA}^{xx} = \int_0^{2b} (1) \cdot 1/EJ \, dx = \left[x \right]_0^{2b} \cdot 1/EJ$$

$$= (2b) \cdot 1/EJ = 2 \cdot b/EJ$$

$$L_{DE}^{xx} = \int_0^b (1 - 2x/b + x^2/b^2) \cdot 1/EJ \, dx = \left[x - x^2/b + 1/3 x^3/b^2 \right]_0^b \cdot 1/EJ$$

$$= (b - b + 1/3 b) \cdot 1/EJ = 1/3 \cdot b/EJ$$

$$L_{ED}^{xx} = \int_0^b (x^2/b^2) \cdot 1/EJ \, dx = \left[1/3 x^3/b^2 \right]_0^b \cdot 1/EJ$$

$$= (1/3 b) \cdot 1/EJ = 1/3 \cdot b/EJ$$

$$L_{AB}^{xo} = \int_0^b (2x/b - 3/2 x^2/b^2 - 1/2 x^3/b^3) \cdot Fb \cdot 1/EJ \, dx + 1 \cdot 0 \cdot 1/4 \cdot Fb^2/EJ$$

$$= \left[x^2/b - 1/2 x^3/b^2 - 1/8 x^4/b^3 \right]_0^b \cdot Fb \cdot 1/EJ + 1 \cdot 0 \cdot 1/4 \cdot Fb^2/EJ$$

$$= (b - 1/2 b - 1/8 b) \cdot Fb \cdot 1/EJ + 1 \cdot 0 \cdot 1/4 \cdot Fb^2/EJ = 3/8 \cdot Fb^2/EJ$$

$$L_{BA}^{xo} = \int_0^b (5/2 x/b - 3 x^2/b^2 + 1/2 x^3/b^3) \cdot Fb \cdot 1/EJ \, dx + 1 \cdot 0 \cdot 1/4 \cdot Fb^2/EJ$$

$$= \left[5/4 x^2/b - x^3/b^2 + 1/8 x^4/b^3 \right]_0^b \cdot Fb \cdot 1/EJ + 1 \cdot 0 \cdot 1/4 \cdot Fb^2/EJ$$

$$= (5/4 b - b + 1/8 b) \cdot Fb \cdot 1/EJ + 1 \cdot 0 \cdot 1/4 \cdot Fb^2/EJ = 3/8 \cdot Fb^2/EJ$$

$$L_{DE}^{xo} = \int_0^b (-1/2 x/b + 1/2 x^2/b^2) \cdot Fb \cdot 1/EJ \, dx = \left[-1/4 x^2/b + 1/6 x^3/b^2 \right]_0^b \cdot Fb \cdot 1/EJ$$

$$= (-1/4 b + 1/6 b) \cdot Fb \cdot 1/EJ = -1/12 \cdot Fb^2/EJ$$

$$L_{ED}^{xo} = \int_0^b (-1/2 x/b + 1/2 x^2/b^2) \cdot Fb \cdot 1/EJ \, dx = \left[-1/4 x^2/b + 1/6 x^3/b^2 \right]_0^b \cdot Fb \cdot 1/EJ$$

$$= (-1/4 b + 1/6 b) \cdot Fb \cdot 1/EJ = -1/12 \cdot Fb^2/EJ$$

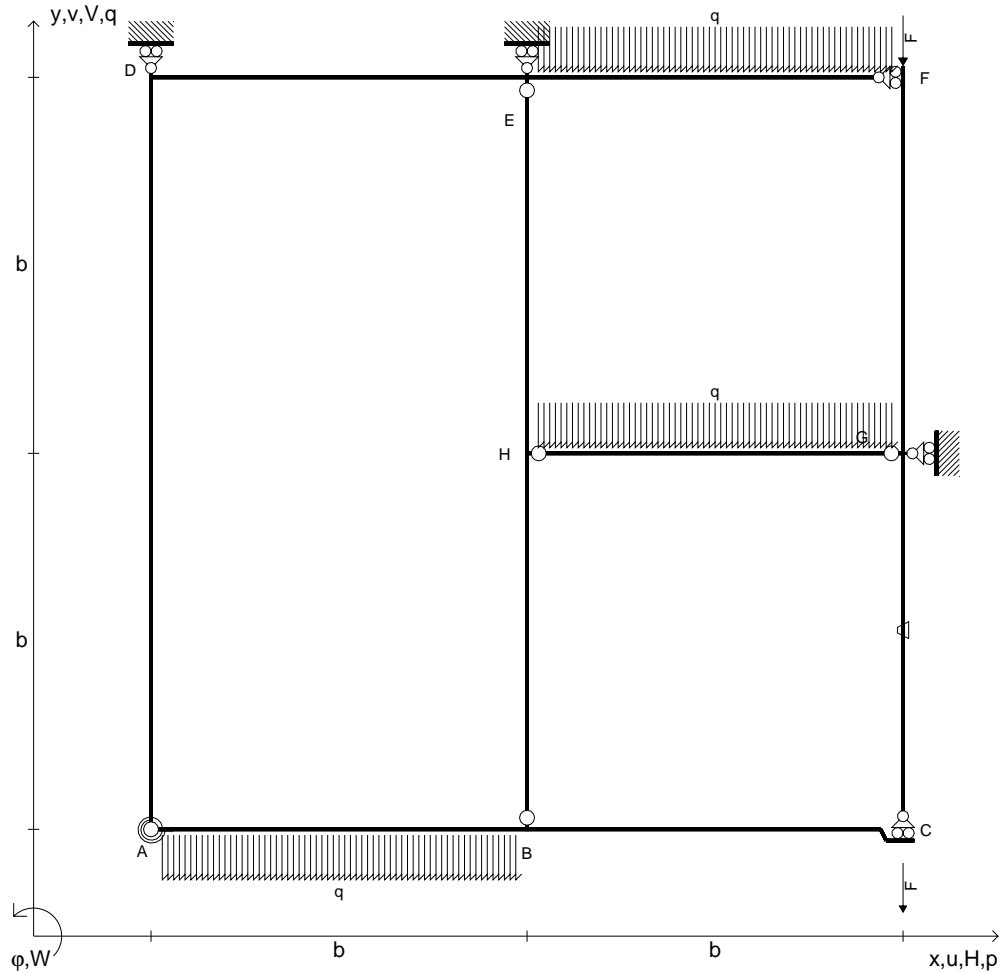

$V_{FG} = -F$	$k_{AB} = 4EJ/b$	$EJ_{FG} = EJ$
$V_{CB} = -F$	$EJ_{AB} = EJ$	$EJ_{GC} = EJ$
$q_{AB} = -q = -F/b$	$EJ_{BC} = EJ$	$EJ_{HG} = EJ$
$q_{EF} = -q = -F/b$	$EJ_{AD} = EJ$	$EJ_{HB} = EJ$
$q_{HG} = -q = -F/b$	$EJ_{DE} = EJ$	$EJ_{HE} = EJ$
$\theta_{GC} = -\theta = -\alpha T/b = -bF/EJ$	$EJ_{EF} = EJ$	

Reazioni iperstatiche in soluzione: $X=W_{AD}$

Carichi e deformazioni date hanno verso efficace in disegno.

Calcolare reazioni vincolari della struttura e delle aste.

Tracciare i diagrammi quotati delle azioni interne nelle aste.

$J_{YZ} - x_{YZ} - \theta_{YZ}$ riferimento locale asta YZ con origine in Y.

Curvatura θ asta GC positiva se convessa a destra con inizio G.

@ Adolfo Zavelani Rossi, Politecnico di Milano, vers.27.03.13

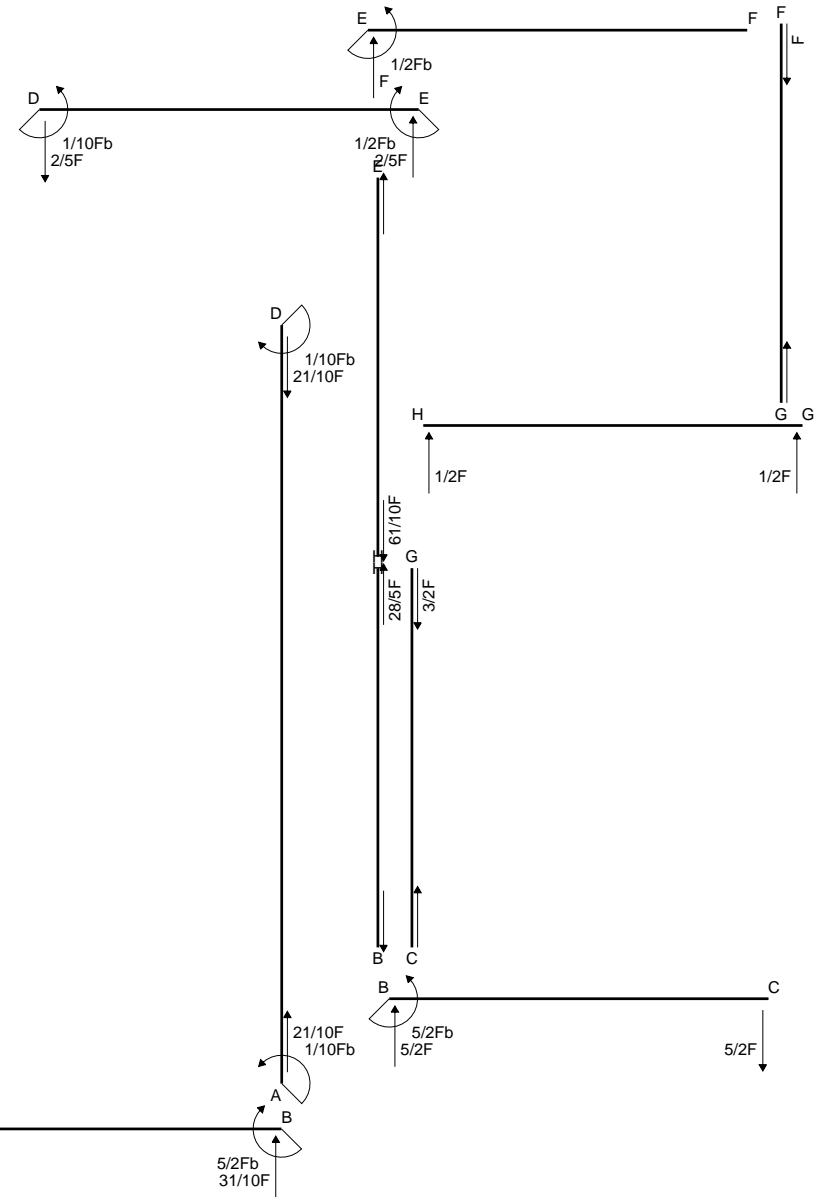

Quadro contributi PLV per iperstatica $X=W_{AD}$

→	$M_x(x)$	$M_o(x)$	θ	$M_x M_o$	$M_x \theta$	$M_x M_x$	$\int M_x(M_o/EJ+\theta)dx$	$\int X M_x M_x/EJ dx$	
AB b	$1-x/b$	$-2Fx-1/2qx^2$	0	$-2Fx+3/2Fx^2/b+1/2qx^3/b$	0	$1-2x/b+x^2/b^2$	$(-3/8+0)Fb^2/EJ$	$1/3Xb/EJ$	
BA b	$-x/b$	$5/2Fb-3Fx+1/2qx^2$	0	$-5/2Fx+3Fx^2/b-1/2qx^3/b$	0	x^2/b^2			
BC b	0	$-5/2Fb+5/2Fx$	0	0	0	0	0+0	0	
CB b	0	$5/2Fx$	0	0	0	0			
AD 2b	-1	0	0	0	0	1	0+0	$2Xb/EJ$	
DA 2b	1	0	0	0	0	1			
DE b	$-1+x/b$	$-1/2Fx$	0	$1/2Fx-1/2Fx^2/b$	0	$1-2x/b+x^2/b^2$	$(1/12+0)Fb^2/EJ$	$1/3Xb/EJ$	
ED b	x/b	$1/2Fb-1/2Fx$	0	$1/2Fx-1/2Fx^2/b$	0	x^2/b^2			
EF b	0	$-1/2Fb+Fx-1/2qx^2$	0	0	0	0	0+0	0	
FE b	0	$1/2qx^2$	0	0	0	0			
FG b	0	0	0	0	0	0	0+0	0	
GF b	0	0	0	0	0	0			
GC b	0	0	$-Fb/EJ$	0	0	0	0+0	0	
CG b	0	0	Fb/EJ	0	0	0			
HG b	0	$1/2Fx-1/2qx^2$	0	0	0	0	0+0	0	
GH b	0	$-1/2Fx+1/2qx^2$	0	0	0	0			
HB b	0	0	0	0	0	0	0+0	0	
BH b	0	0	0	0	0	0			
HE b	0	0	0	0	0	0	0+0	0	
EH b	0	0	0	0	0	0			
AB	molla asta $-W_{1AB}(W_{0AB}+XW_{1AB})/k_{AB}$								$1/4Xb/EJ$
	totali							$-7/24Fb^2/EJ$	$35/12Xb/EJ$
	iperstatica $X=W_{AD}$							$1/10Fb$	

Sviluppi di calcolo iperstatica

$$L_{AB}^{xx} = \int_0^b (1 - 2x/b + x^2/b^2) \cdot 1/EJ \, dx - 1 \cdot (-1) \cdot 1/4 \cdot b/EJ = \left[x - x^2/b + 1/3 x^3/b^2 \right]_0^b \cdot 1/EJ - 1 \cdot (-1) \cdot 1/4 \cdot b/EJ$$

$$= (b - b + 1/3 b) \cdot 1/EJ - 1 \cdot (-1) \cdot 1/4 \cdot b/EJ = 7/12 \cdot b/EJ$$

$$L_{BA}^{xx} = \int_0^b (x^2/b^2) \cdot 1/EJ \, dx - 1 \cdot (-1) \cdot 1/4 \cdot b/EJ = \left[1/3 x^3/b^2 \right]_0^b \cdot 1/EJ - 1 \cdot (-1) \cdot 1/4 \cdot b/EJ$$

$$= (1/3 b) \cdot 1/EJ - 1 \cdot (-1) \cdot 1/4 \cdot b/EJ = 7/12 \cdot b/EJ$$

$$L_{AD}^{xx} = \int_0^{2b} (1) \cdot 1/EJ \, dx = \left[x \right]_0^{2b} \cdot 1/EJ$$

$$= (2b) \cdot 1/EJ = 2 \cdot b/EJ$$

$$L_{DA}^{xx} = \int_0^{2b} (1) \cdot 1/EJ \, dx = \left[x \right]_0^{2b} \cdot 1/EJ$$

$$= (2b) \cdot 1/EJ = 2 \cdot b/EJ$$

$$L_{DE}^{xx} = \int_0^b (1 - 2x/b + x^2/b^2) \cdot 1/EJ \, dx = \left[x - x^2/b + 1/3 x^3/b^2 \right]_0^b \cdot 1/EJ$$

$$= (b - b + 1/3 b) \cdot 1/EJ = 1/3 \cdot b/EJ$$

$$L_{ED}^{xx} = \int_0^b (x^2/b^2) \cdot 1/EJ \, dx = \left[1/3 x^3/b^2 \right]_0^b \cdot 1/EJ$$

$$= (1/3 b) \cdot 1/EJ = 1/3 \cdot b/EJ$$

$$L_{AB}^{xo} = \int_0^b (-2x/b + 3/2 x^2/b^2 + 1/2 x^3/b^3) \cdot Fb \cdot 1/EJ \, dx - 1 \cdot 0 \cdot 1/4 \cdot Fb^2/EJ$$

$$= \left[-x^2/b + 1/2 x^3/b^2 + 1/8 x^4/b^3 \right]_0^b \cdot Fb \cdot 1/EJ - 1 \cdot 0 \cdot 1/4 \cdot Fb^2/EJ$$

$$= (-b + 1/2 b + 1/8 b) \cdot Fb \cdot 1/EJ - 1 \cdot 0 \cdot 1/4 \cdot Fb^2/EJ = -3/8 \cdot Fb^2/EJ$$

$$L_{BA}^{xo} = \int_0^b (-5/2 x/b + 3 x^2/b^2 - 1/2 x^3/b^3) \cdot Fb \cdot 1/EJ \, dx - 1 \cdot 0 \cdot 1/4 \cdot Fb^2/EJ$$

$$= \left[-5/4 x^2/b + x^3/b^2 - 1/8 x^4/b^3 \right]_0^b \cdot Fb \cdot 1/EJ - 1 \cdot 0 \cdot 1/4 \cdot Fb^2/EJ$$

$$= (-5/4 b + b - 1/8 b) \cdot Fb \cdot 1/EJ - 1 \cdot 0 \cdot 1/4 \cdot Fb^2/EJ = -3/8 \cdot Fb^2/EJ$$

$$L_{DE}^{xo} = \int_0^b (1/2 x/b - 1/2 x^2/b^2) \cdot Fb \cdot 1/EJ \, dx = \left[1/4 x^2/b - 1/6 x^3/b^2 \right]_0^b \cdot Fb \cdot 1/EJ$$

$$= (1/4 b - 1/6 b) \cdot Fb \cdot 1/EJ = 1/12 \cdot Fb^2/EJ$$

$$L_{ED}^{xo} = \int_0^b (1/2 x/b - 1/2 x^2/b^2) \cdot Fb \cdot 1/EJ \, dx = \left[1/4 x^2/b - 1/6 x^3/b^2 \right]_0^b \cdot Fb \cdot 1/EJ$$

$$= (1/4 b - 1/6 b) \cdot Fb \cdot 1/EJ = 1/12 \cdot Fb^2/EJ$$

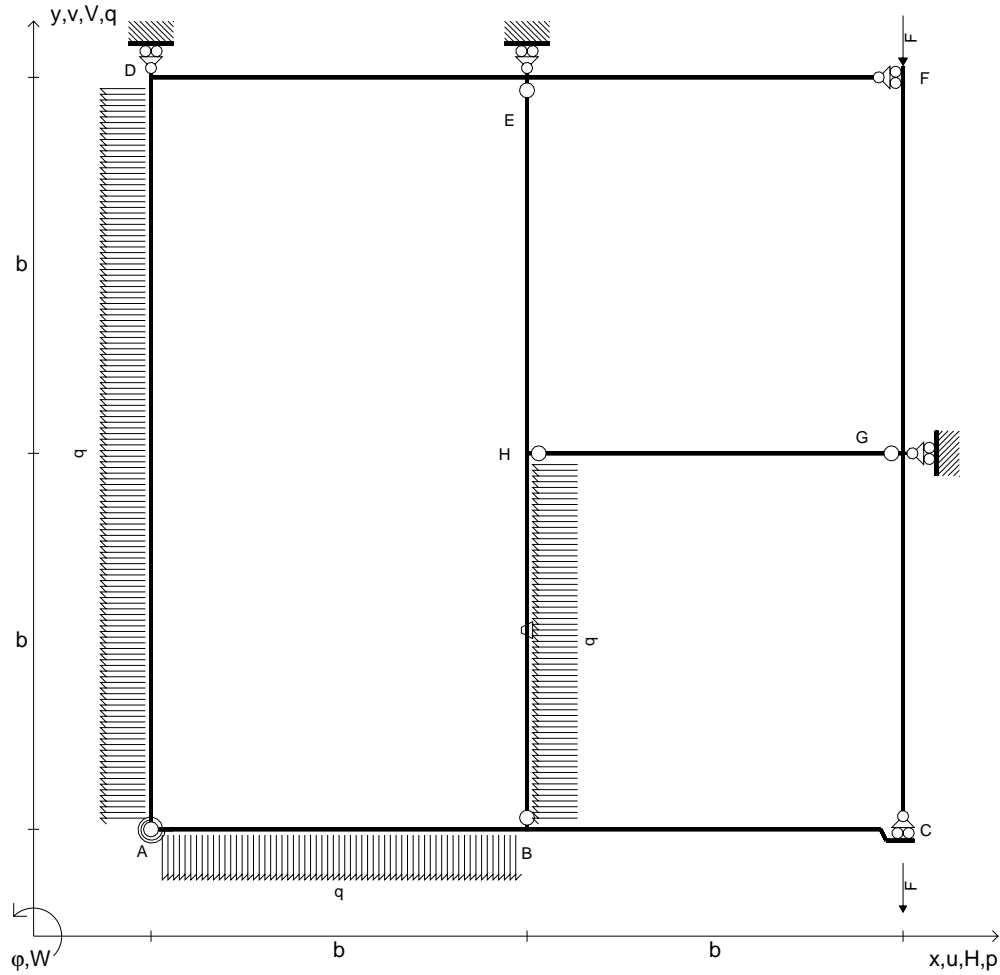

$V_{FG} = -F$	$k_{AB} = 4EJ/b$	$EJ_{FG} = EJ$
$V_{CB} = -F$	$EJ_{AB} = EJ$	$EJ_{GC} = EJ$
$q_{AB} = -q = -F/b$	$EJ_{BC} = EJ$	$EJ_{HG} = EJ$
$p_{AD} = -q = -F/b$	$EJ_{AD} = EJ$	$EJ_{HB} = EJ$
$p_{HB} = -q = -F/b$	$EJ_{DE} = EJ$	$EJ_{HE} = EJ$
$\theta_{HB} = -\theta = -\alpha T/b = -bF/EJ$	$EJ_{EF} = EJ$	

Reazioni iperstatiche in soluzione: $X=W_{AD}$
 Carichi e deformazioni date hanno verso efficace in disegno.
 Calcolare reazioni vincolari della struttura e delle aste.
 Tracciare i diagrammi quotati delle azioni interne nelle aste.
 $J_{YZ} - x_{YZ} - \theta_{YZ}$ riferimento locale asta YZ con origine in Y.
 Curvatura θ asta HB positiva se convessa a destra con inizio H.
 © Adolfo Zavelani Rossi, Politecnico di Milano, vers.27.03.13

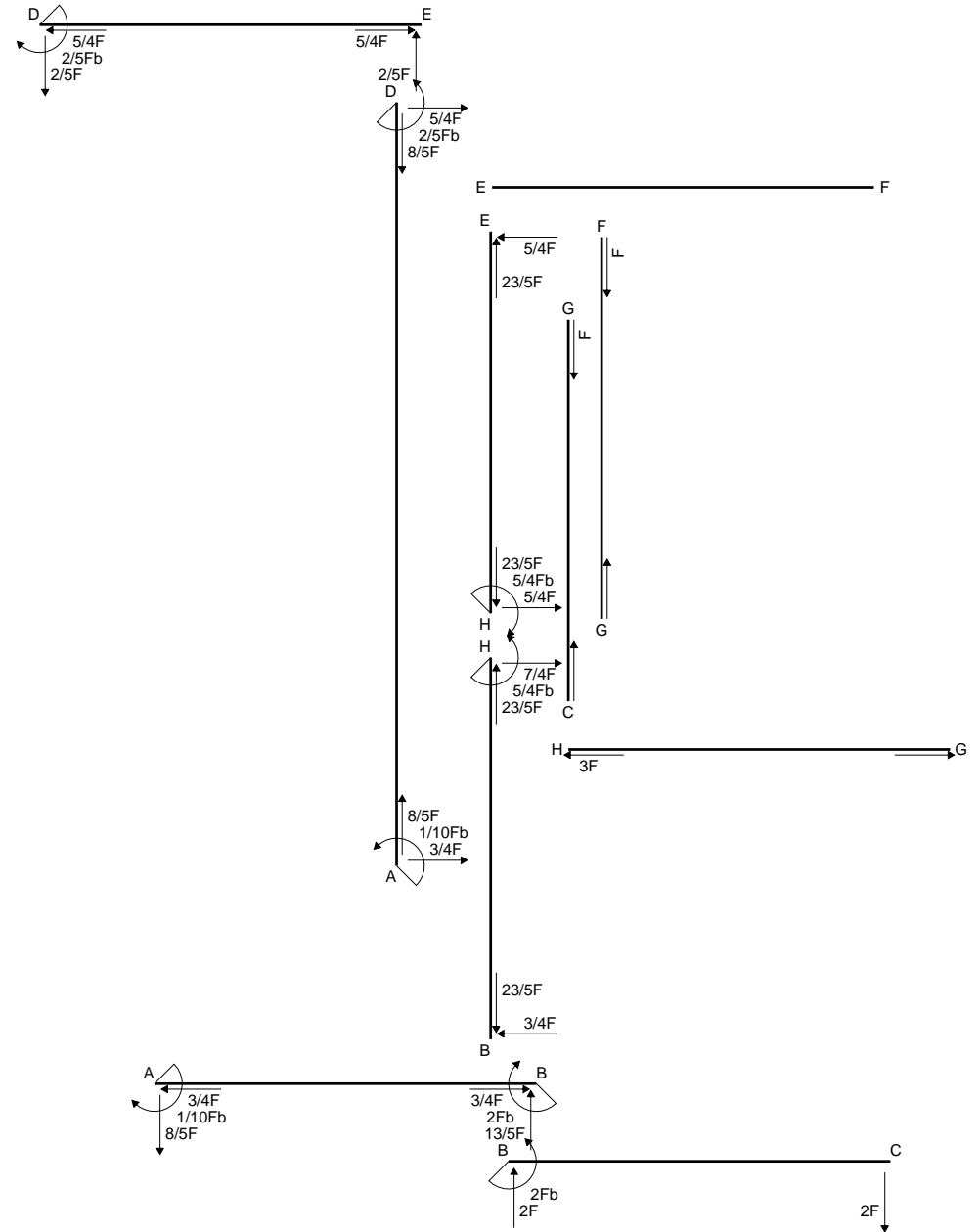

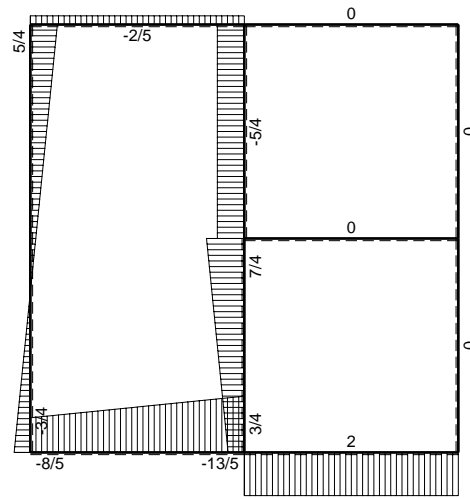
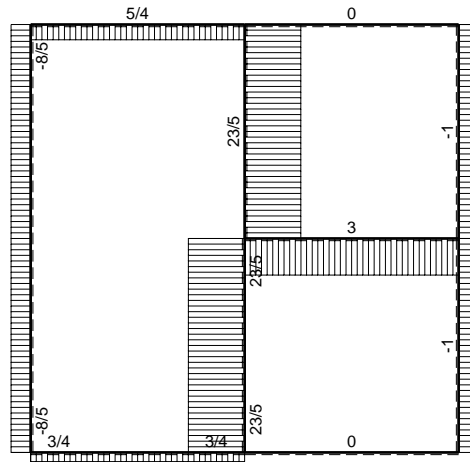

← ⊕ → F

↑ ⊕ ↓ F

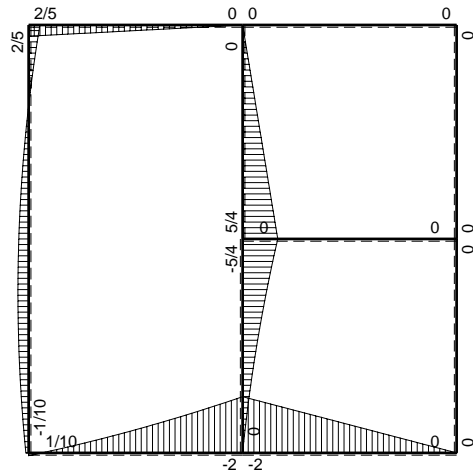

⊕ F_b

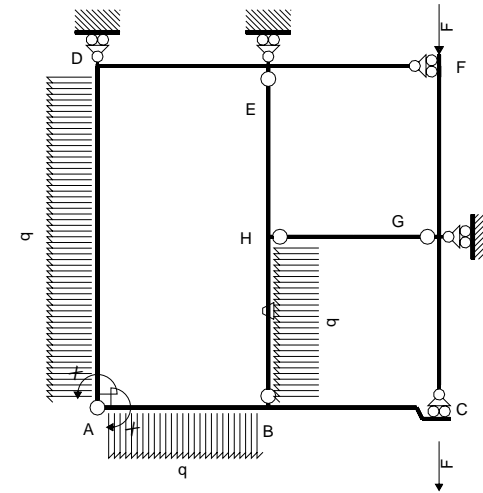

Schema di calcolo iperstatico

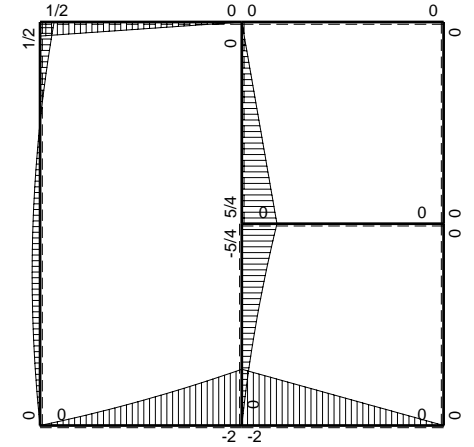

⊕ M_o flessione da carichi assegnati

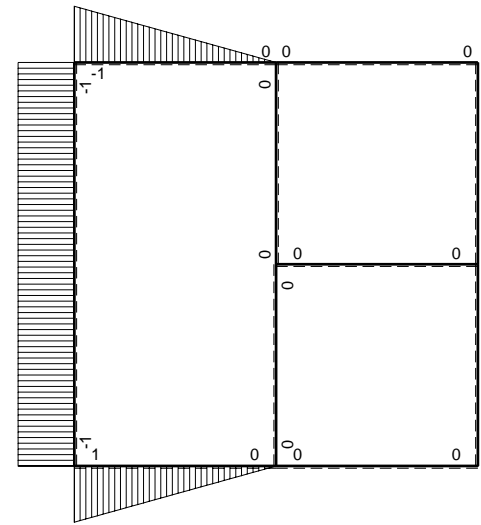

⊕ M_x flessione da iperstatica X=1

Quadro contributi PLV per iperstatica $X=W_{AD}$

→	$M_x(x)$	$M_o(x)$	θ	$M_x M_o$	$M_x \theta$	$M_x M_x$	$\int M_x(M_o/EJ+\theta)dx$	$\int X M_x M_x/EJ dx$	
AB b	$1-x/b$	$-3/2Fx-1/2qx^2$	0	$-3/2Fx+Fx^2/b+1/2qx^3/b$	0	$1-2x/b+x^2/b^2$	$(-7/24+0)Fb^2/EJ$	$1/3Xb/EJ$	
BA b	$-x/b$	$2Fb-5/2Fx+1/2qx^2$	0	$-2Fx+5/2Fx^2/b-1/2qx^3/b$	0	x^2/b^2			
BC b	0	$-2Fb+2Fx$	0	0	0	0	0+0	0	
CB b	0	$2Fx$	0	0	0	0			
AD 2b	-1	$-3/4Fx+1/2qx^2$	0	$3/4Fx-1/2Fx^2/b$	0	1	$(1/6+0)Fb^2/EJ$	$2Xb/EJ$	
DA 2b	1	$-1/2Fb+5/4Fx-1/2qx^2$	0	$-1/2Fb+5/4Fx-1/2Fx^2/b$	0	1			
DE b	$-1+x/b$	$1/2Fb-1/2Fx$	0	$-1/2Fb+Fx-1/2Fx^2/b$	0	$1-2x/b+x^2/b^2$	$(-1/6+0)Fb^2/EJ$	$1/3Xb/EJ$	
ED b	x/b	$-1/2Fx$	0	$-1/2Fx^2/b$	0	x^2/b^2			
EF b	0	0	0	0	0	0	0+0	0	
FE b	0	0	0	0	0	0			
FG b	0	0	0	0	0	0	0+0	0	
GF b	0	0	0	0	0	0			
GC b	0	0	0	0	0	0	0+0	0	
CG b	0	0	0	0	0	0			
HG b	0	0	0	0	0	0	0+0	0	
GH b	0	0	0	0	0	0			
HB b	0	$-5/4Fb+7/4Fx-1/2qx^2$	$-Fb/EJ$	0	0	0	0+0	0	
BH b	0	$3/4Fx+1/2qx^2$	Fb/EJ	0	0	0			
HE b	0	$5/4Fb-5/4Fx$	0	0	0	0	0+0	0	
EH b	0	$-5/4Fx$	0	0	0	0			
AB	molla asta $-W_{1AB}(W_{0AB}+XW_{1AB})/k_{AB}$								$1/4Xb/EJ$
	totali							$-7/24Fb^2/EJ$	$35/12Xb/EJ$
	iperstatica $X=W_{AD}$							$1/10Fb$	

Sviluppi di calcolo iperstatica

$$L_{AB}^{xx} = \int_0^b (1 - 2x/b + x^2/b^2) \cdot 1/EJ \, dx - 1 \cdot (-1) \cdot 1/4 \cdot b/EJ = \left[x - x^2/b + 1/3 x^3/b^2 \right]_0^b \cdot 1/EJ - 1 \cdot (-1) \cdot 1/4 \cdot b/EJ$$

$$= (b - b + 1/3 b) \cdot 1/EJ - 1 \cdot (-1) \cdot 1/4 \cdot b/EJ = 7/12 \cdot b/EJ$$

$$L_{BA}^{xx} = \int_0^b (x^2/b^2) \cdot 1/EJ \, dx - 1 \cdot (-1) \cdot 1/4 \cdot b/EJ = \left[1/3 x^3/b^2 \right]_0^b \cdot 1/EJ - 1 \cdot (-1) \cdot 1/4 \cdot b/EJ$$

$$= (1/3 b) \cdot 1/EJ - 1 \cdot (-1) \cdot 1/4 \cdot b/EJ = 7/12 \cdot b/EJ$$

$$L_{AD}^{xx} = \int_0^{2b} (1) \cdot 1/EJ \, dx = \left[x \right]_0^{2b} \cdot 1/EJ$$

$$= (2b) \cdot 1/EJ = 2 \cdot b/EJ$$

$$L_{DA}^{xx} = \int_0^{2b} (1) \cdot 1/EJ \, dx = \left[x \right]_0^{2b} \cdot 1/EJ$$

$$= (2b) \cdot 1/EJ = 2 \cdot b/EJ$$

$$L_{DE}^{xx} = \int_0^b (1 - 2x/b + x^2/b^2) \cdot 1/EJ \, dx = \left[x - x^2/b + 1/3 x^3/b^2 \right]_0^b \cdot 1/EJ$$

$$= (b - b + 1/3 b) \cdot 1/EJ = 1/3 \cdot b/EJ$$

$$L_{ED}^{xx} = \int_0^b (x^2/b^2) \cdot 1/EJ \, dx = \left[1/3 x^3/b^2 \right]_0^b \cdot 1/EJ$$

$$= (1/3 b) \cdot 1/EJ = 1/3 \cdot b/EJ$$

$$L_{AB}^{xo} = \int_0^b (-3/2 x/b + x^2/b^2 + 1/2 x^3/b^3) \cdot Fb \cdot 1/EJ \, dx - 1 \cdot 0 \cdot 1/4 \cdot Fb^2/EJ$$

$$= \left[-3/4 x^2/b + 1/3 x^3/b^2 + 1/8 x^4/b^3 \right]_0^b \cdot Fb \cdot 1/EJ - 1 \cdot 0 \cdot 1/4 \cdot Fb^2/EJ$$

$$= (-3/4 b + 1/3 b + 1/8 b) \cdot Fb \cdot 1/EJ - 1 \cdot 0 \cdot 1/4 \cdot Fb^2/EJ = -7/24 \cdot Fb^2/EJ$$

$$L_{BA}^{xo} = \int_0^b (-2x/b + 5/2 x^2/b^2 - 1/2 x^3/b^3) \cdot Fb \cdot 1/EJ \, dx - 1 \cdot 0 \cdot 1/4 \cdot Fb^2/EJ$$

$$= \left[-x^2/b + 5/6 x^3/b^2 - 1/8 x^4/b^3 \right]_0^b \cdot Fb \cdot 1/EJ - 1 \cdot 0 \cdot 1/4 \cdot Fb^2/EJ$$

$$= (-b + 5/6 b - 1/8 b) \cdot Fb \cdot 1/EJ - 1 \cdot 0 \cdot 1/4 \cdot Fb^2/EJ = -7/24 \cdot Fb^2/EJ$$

$$L_{AD}^{xo} = \int_0^{2b} (3/4 x/b - 1/2 x^2/b^2) \cdot Fb \cdot 1/EJ \, dx = \left[3/8 x^2/b - 1/6 x^3/b^2 \right]_0^{2b} \cdot Fb \cdot 1/EJ$$

$$= (3/2 b - 4/3 b) \cdot Fb \cdot 1/EJ = 1/6 \cdot Fb^2/EJ$$

$$L_{DA}^{xo} = \int_0^{2b} (-1/2 + 5/4 x/b - 1/2 x^2/b^2) \cdot Fb \cdot 1/EJ \, dx = \left[-1/2 x + 5/8 x^2/b - 1/6 x^3/b^2 \right]_0^{2b} \cdot Fb \cdot 1/EJ$$

$$= (-b + 5/2 b - 4/3 b) \cdot Fb \cdot 1/EJ = 1/6 \cdot Fb^2/EJ$$

$$L_{DE}^{xo} = \int_0^b (-1/2 + x/b - 1/2 x^2/b^2) \cdot Fb \cdot 1/EJ \, dx = \left[-1/2 x + 1/2 x^2/b - 1/6 x^3/b^2 \right]_0^b \cdot Fb \cdot 1/EJ$$

$$= (-1/2 b + 1/2 b - 1/6 b) \cdot Fb \cdot 1/EJ = -1/6 \cdot Fb^2/EJ$$

$$L_{ED}^{xo} = \int_0^b (-1/2 x^2/b^2) \cdot Fb \cdot 1/EJ \, dx = \left[-1/6 x^3/b^2 \right]_0^b \cdot Fb \cdot 1/EJ$$

$$= (-1/6 b) \cdot Fb \cdot 1/EJ = -1/6 \cdot Fb^2/EJ$$

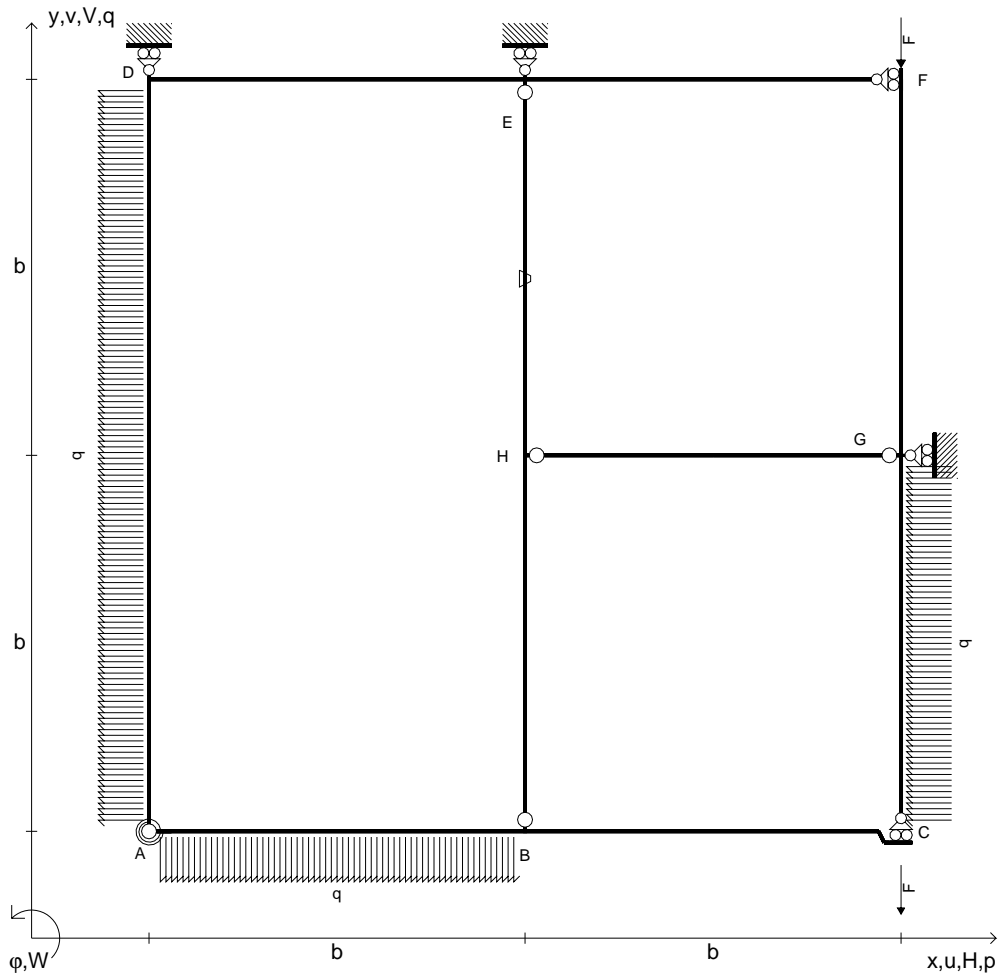

$V_{FG} = -F$	$k_{AB} = 4EJ/b$	$EJ_{FG} = EJ$
$V_{CB} = -F$	$EJ_{AB} = EJ$	$EJ_{GC} = EJ$
$q_{AB} = -q = -F/b$	$EJ_{BC} = EJ$	$EJ_{HG} = EJ$
$p_{AD} = -q = -F/b$	$EJ_{AD} = EJ$	$EJ_{HB} = EJ$
$p_{GC} = -q = -F/b$	$EJ_{DE} = EJ$	$EJ_{HE} = EJ$
$\theta_{HE} = -\theta = -\alpha T/b = -bF/EJ$	$EJ_{EF} = EJ$	

Reazioni iperstatiche in soluzione: $X=W_{DE}$
 Carichi e deformazioni date hanno verso efficace in disegno.
 Calcolare reazioni vincolari della struttura e delle aste.
 Tracciare i diagrammi quotati delle azioni interne nelle aste.
 $J_{YZ} - x_{YZ} - \theta_{YZ}$ riferimento locale asta YZ con origine in Y.
 Curvatura θ asta HE positiva se convessa a destra con inizio H.
 © Adolfo Zavelani Rossi, Politecnico di Milano, vers.27.03.13

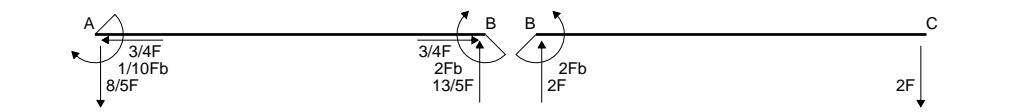
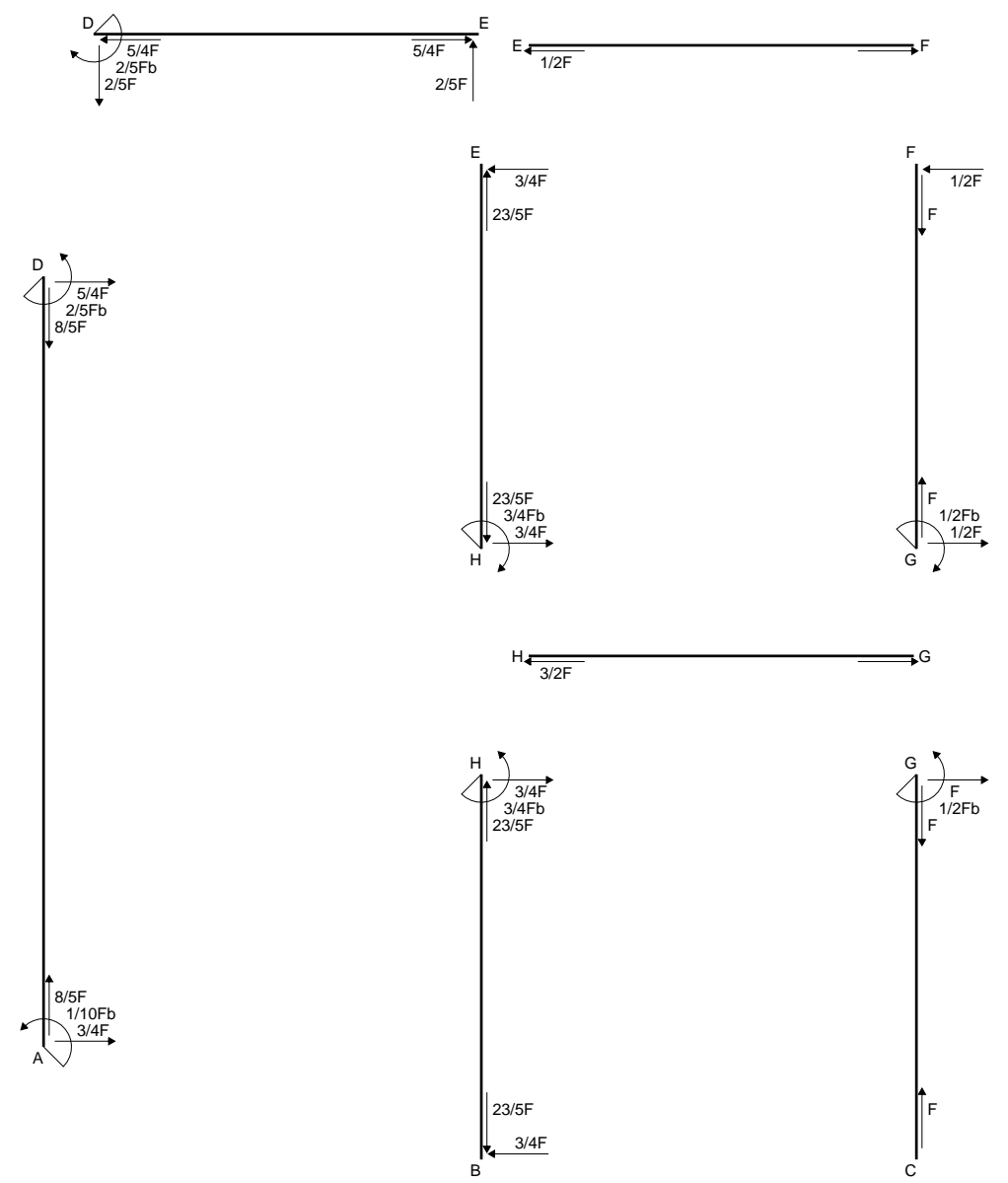

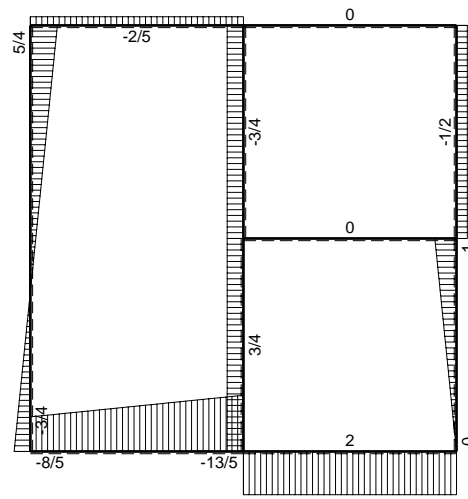
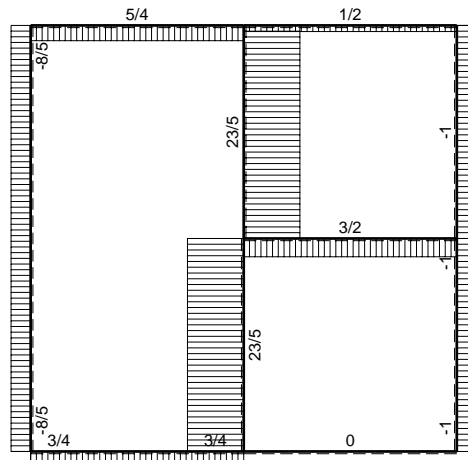

← ⊕ → F

↑ ⊕ ↓ F

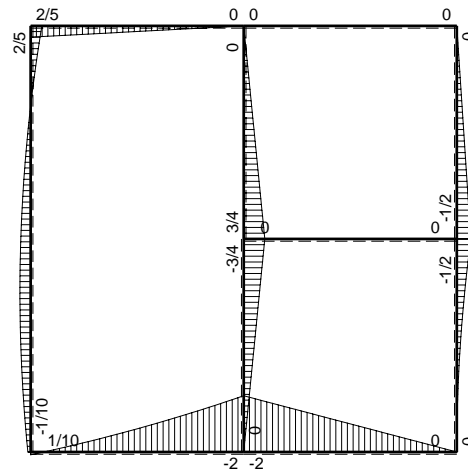

⊕ F_b

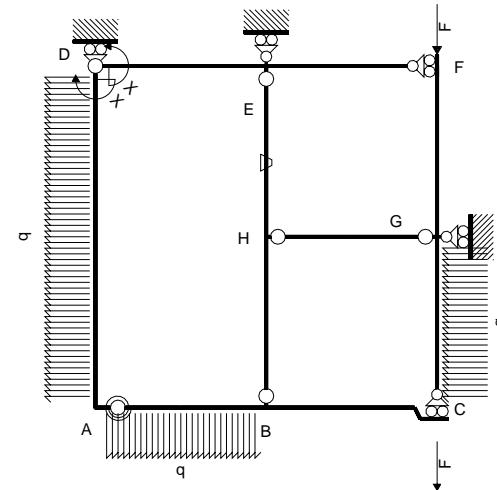

Schema di calcolo iperstatico

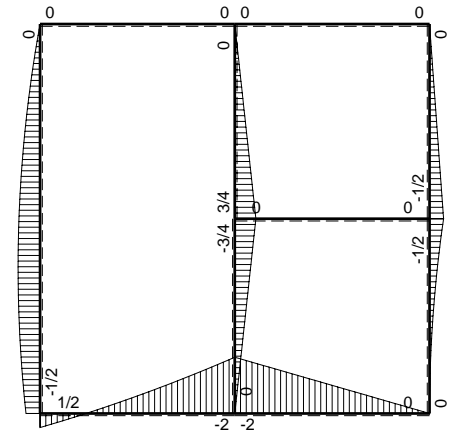

⊕ M_o flessione da carichi assegnati

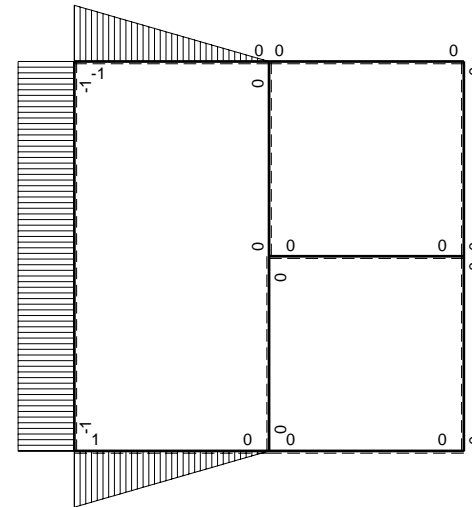

⊕ M_x flessione da iperstatica X=1

Quadro contributi PLV per iperstatica $X=W_{DE}$

→	$M_x(x)$	$M_o(x)$	θ	$M_x M_o$	$M_x \theta$	$M_x M_x$	$\int M_x(M_o/EJ+\theta)dx$	$\int X M_x M_x/EJ dx$	
AB b	$1-x/b$	$1/2Fb-2Fx-1/2qx^2$	0	$1/2Fb-5/2Fx+3/2Fx^2/b+1/2qx^3/b$	0	$1-2x/b+x^2/b^2$	$(-1/8+0)Fb^2/EJ$	$1/3Xb/EJ$	
BA b	$-x/b$	$2Fb-3Fx+1/2qx^2$	0	$-2Fx+3Fx^2/b-1/2qx^3/b$	0	x^2/b^2			
BC b	0	$-2Fb+2Fx$	0	0	0	0	0+0	0	
CB b	0	$2Fx$	0	0	0	0			
AD 2b	-1	$-1/2Fb-3/4Fx+1/2qx^2$	0	$1/2Fb+3/4Fx-1/2Fx^2/b$	0	1	$(7/6+0)Fb^2/EJ$	$2Xb/EJ$	
DA 2b	1	$5/4Fx-1/2qx^2$	0	$5/4Fx-1/2Fx^2/b$	0	1			
DE b	$-1+x/b$	0	0	0	0	$1-2x/b+x^2/b^2$	0+0	$1/3Xb/EJ$	
ED b	x/b	0	0	0	0	x^2/b^2			
EF b	0	0	0	0	0	0	0+0	0	
FE b	0	0	0	0	0	0			
FG b	0	$-1/2Fx$	0	0	0	0	0+0	0	
GF b	0	$1/2Fb-1/2Fx$	0	0	0	0			
GC b	0	$-1/2Fb+Fx-1/2qx^2$	0	0	0	0	0+0	0	
CG b	0	$1/2qx^2$	0	0	0	0			
HG b	0	0	0	0	0	0	0+0	0	
GH b	0	0	0	0	0	0			
HB b	0	$-3/4Fb+3/4Fx$	0	0	0	0	0+0	0	
BH b	0	$3/4Fx$	0	0	0	0			
HE b	0	$3/4Fb-3/4Fx$	$-Fb/EJ$	0	0	0	0+0	0	
EH b	0	$-3/4Fx$	Fb/EJ	0	0	0			
AB	molla asta $-W_{1AB}(W_{0AB}+XW_{1AB})/k_{AB}$							$1/8Fb^2/EJ$	$1/4Xb/EJ$
	totali							$7/6Fb^2/EJ$	$35/12Xb/EJ$
	iperstatica $X=W_{DE}$							$-2/5Fb$	

Sviluppi di calcolo iperstatica

$$L_{AB}^{xx} = \int_0^b (1 - 2x/b + x^2/b^2) \cdot 1/EJ \, dx - 1 \cdot (-1) \cdot 1/4 \cdot b/EJ = \left[x - x^2/b + 1/3 x^3/b^2 \right]_0^b \cdot 1/EJ - 1 \cdot (-1) \cdot 1/4 \cdot b/EJ$$

$$= (b - b + 1/3 b) \cdot 1/EJ - 1 \cdot (-1) \cdot 1/4 \cdot b/EJ = 7/12 \cdot b/EJ$$

$$L_{BA}^{xx} = \int_0^b (x^2/b^2) \cdot 1/EJ \, dx - 1 \cdot (-1) \cdot 1/4 \cdot b/EJ = \left[1/3 x^3/b^2 \right]_0^b \cdot 1/EJ - 1 \cdot (-1) \cdot 1/4 \cdot b/EJ$$

$$= (1/3 b) \cdot 1/EJ - 1 \cdot (-1) \cdot 1/4 \cdot b/EJ = 7/12 \cdot b/EJ$$

$$L_{AD}^{xx} = \int_0^{2b} (1) \cdot 1/EJ \, dx = \left[x \right]_0^{2b} \cdot 1/EJ$$

$$= (2b) \cdot 1/EJ = 2 \cdot b/EJ$$

$$L_{DA}^{xx} = \int_0^{2b} (1) \cdot 1/EJ \, dx = \left[x \right]_0^{2b} \cdot 1/EJ$$

$$= (2b) \cdot 1/EJ = 2 \cdot b/EJ$$

$$L_{DE}^{xx} = \int_0^b (1 - 2x/b + x^2/b^2) \cdot 1/EJ \, dx = \left[x - x^2/b + 1/3 x^3/b^2 \right]_0^b \cdot 1/EJ$$

$$= (b - b + 1/3 b) \cdot 1/EJ = 1/3 \cdot b/EJ$$

$$L_{ED}^{xx} = \int_0^b (x^2/b^2) \cdot 1/EJ \, dx = \left[1/3 x^3/b^2 \right]_0^b \cdot 1/EJ$$

$$= (1/3 b) \cdot 1/EJ = 1/3 \cdot b/EJ$$

$$L_{AB}^{xo} = \int_0^b (1/2 - 5/2 x/b + 3/2 x^2/b^2 + 1/2 x^3/b^3) \cdot Fb \cdot 1/EJ \, dx - 1 \cdot (-1/2) \cdot 1/4 \cdot Fb^2/EJ$$

$$= \left[1/2 x - 5/4 x^2/b + 1/2 x^3/b^2 + 1/8 x^4/b^3 \right]_0^b \cdot Fb \cdot 1/EJ - 1 \cdot (-1/2) \cdot 1/4 \cdot Fb^2/EJ$$

$$= (1/2 b - 5/4 b + 1/2 b + 1/8 b) \cdot Fb \cdot 1/EJ - 1 \cdot (-1/2) \cdot 1/4 \cdot Fb^2/EJ = 0$$

$$L_{BA}^{xo} = \int_0^b (-2x/b + 3x^2/b^2 - 1/2 x^3/b^3) \cdot Fb \cdot 1/EJ \, dx - 1 \cdot (-1/2) \cdot 1/4 \cdot Fb^2/EJ$$

$$= \left[-x^2/b + x^3/b^2 - 1/8 x^4/b^3 \right]_0^b \cdot Fb \cdot 1/EJ - 1 \cdot (-1/2) \cdot 1/4 \cdot Fb^2/EJ$$

$$= (-b + b - 1/8 b) \cdot Fb \cdot 1/EJ - 1 \cdot (-1/2) \cdot 1/4 \cdot Fb^2/EJ = 0$$

$$L_{AD}^{xo} = \int_0^{2b} (1/2 + 3/4 x/b - 1/2 x^2/b^2) \cdot Fb \cdot 1/EJ \, dx = \left[1/2 x + 3/8 x^2/b - 1/6 x^3/b^2 \right]_0^{2b} \cdot Fb \cdot 1/EJ$$

$$= (b + 3/2 b - 4/3 b) \cdot Fb \cdot 1/EJ = 7/6 \cdot Fb^2/EJ$$

$$L_{DA}^{xo} = \int_0^{2b} (5/4 x/b - 1/2 x^2/b^2) \cdot Fb \cdot 1/EJ \, dx = \left[5/8 x^2/b - 1/6 x^3/b^2 \right]_0^{2b} \cdot Fb \cdot 1/EJ$$

$$= (5/2 b - 4/3 b) \cdot Fb \cdot 1/EJ = 7/6 \cdot Fb^2/EJ$$

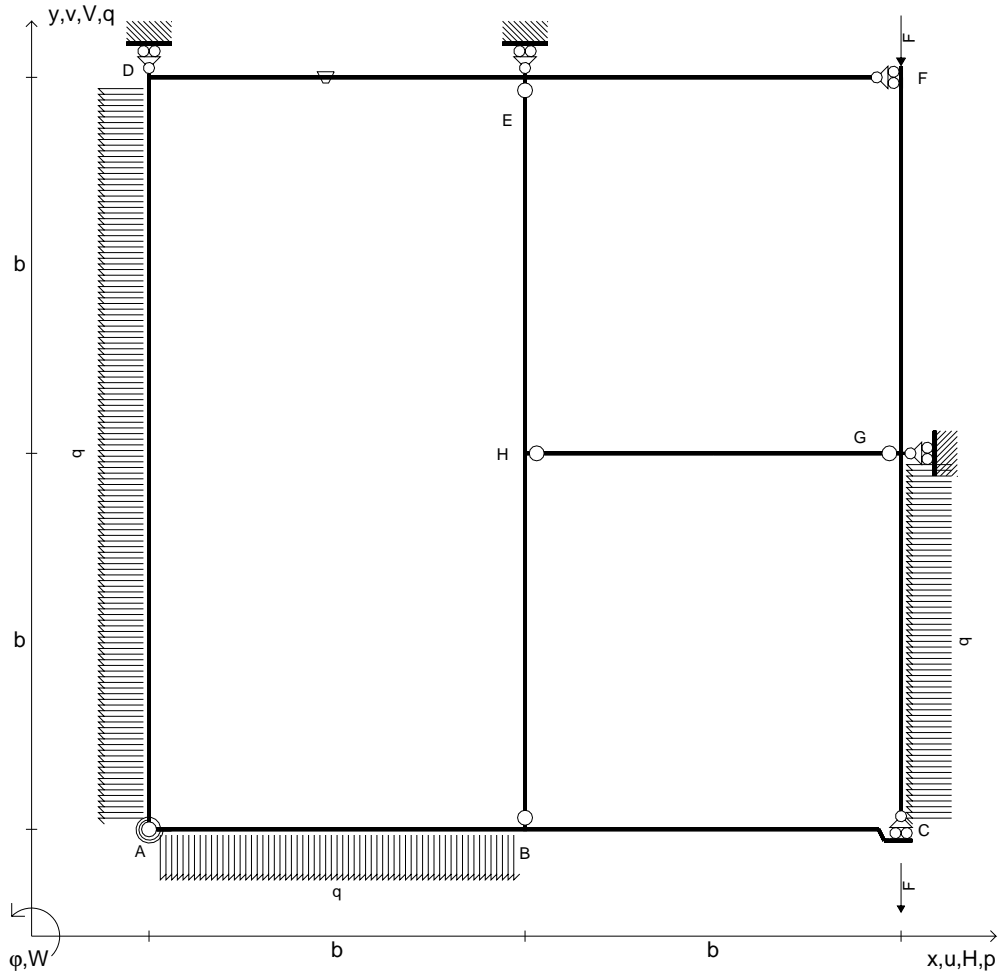

$V_{FG} = -F$	$k_{AB} = 4EJ/b$	$EJ_{FG} = EJ$
$V_{CB} = -F$	$EJ_{AB} = EJ$	$EJ_{GC} = EJ$
$q_{AB} = -q = -F/b$	$EJ_{BC} = EJ$	$EJ_{HG} = EJ$
$p_{AD} = -q = -F/b$	$EJ_{AD} = EJ$	$EJ_{HB} = EJ$
$p_{GC} = -q = -F/b$	$EJ_{DE} = EJ$	$EJ_{HE} = EJ$
$\theta_{DE} = -\theta = -\alpha T/b = -bF/EJ$	$EJ_{EF} = EJ$	

Reazioni iperstatiche in soluzione: $X=W_{AB}$

Carichi e deformazioni date hanno verso efficace in disegno.

Calcolare reazioni vincolari della struttura e delle aste.

Tracciare i diagrammi quotati delle azioni interne nelle aste.

$J_{YZ} - x_{YZ} - \theta_{YZ}$ riferimento locale asta YZ con origine in Y.

Curvatura θ asta DE positiva se convessa a destra con inizio D.

@ Adolfo Zavelani Rossi, Politecnico di Milano, vers.27.03.13

08.01.25

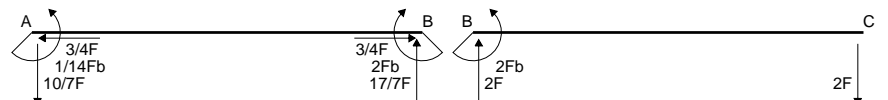
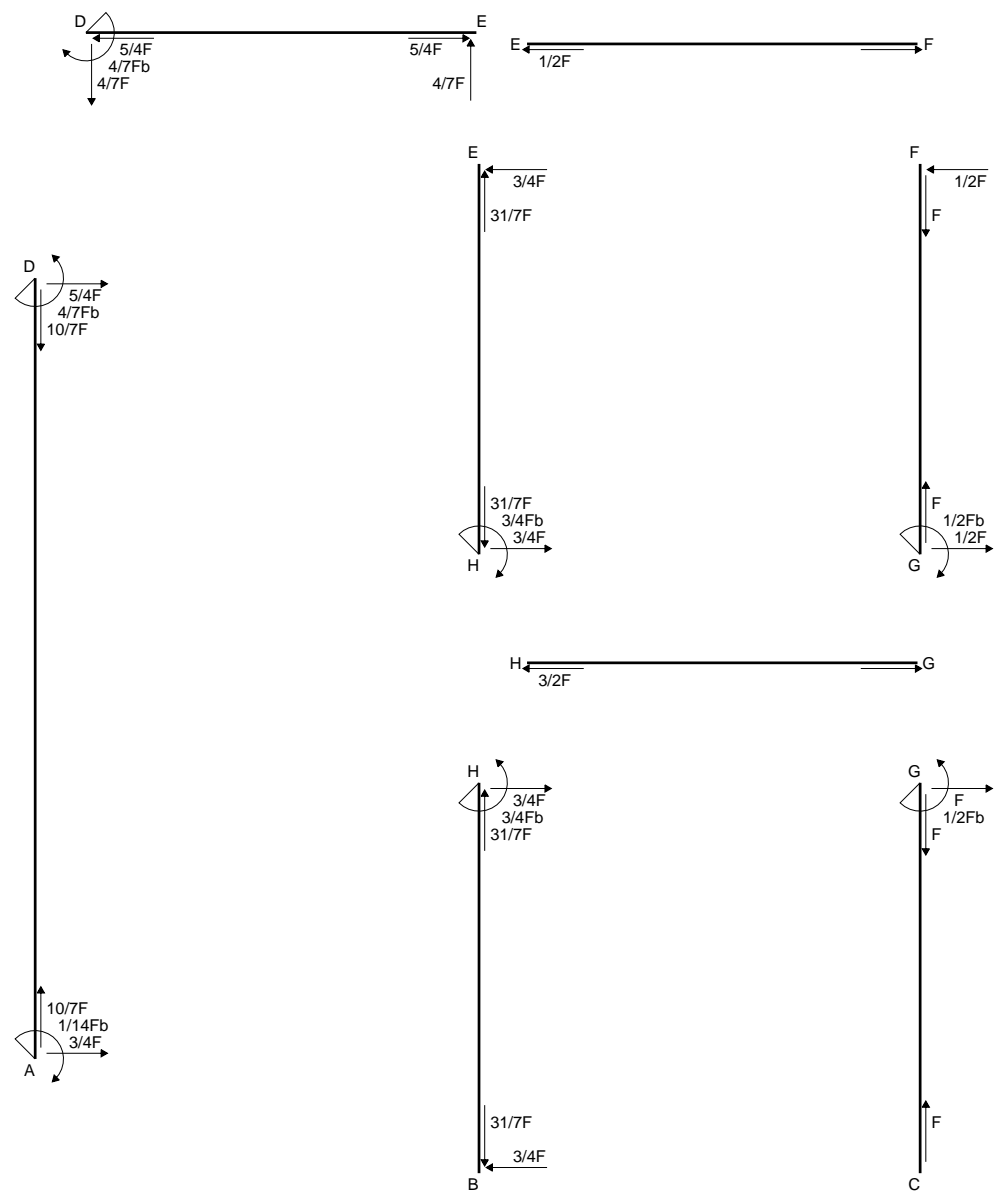

@ Adolfo Zavelani Rossi, Politecnico di Milano, vers.27.03.13

08.01.25

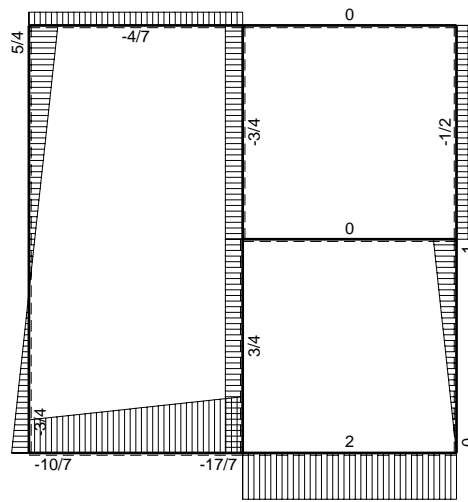
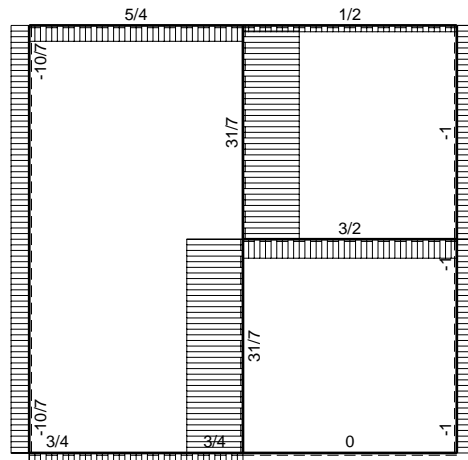

← ⊕ → F

↑ ⊕ ↓ F

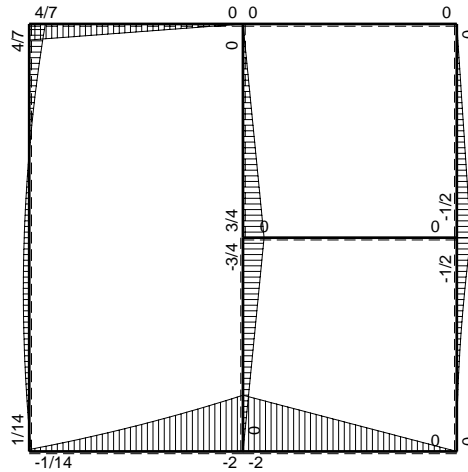

⊕ F_b

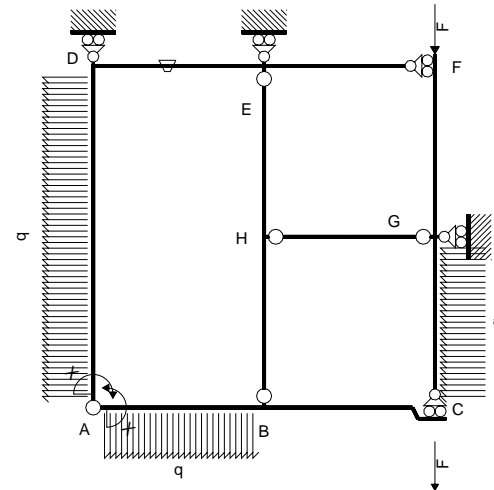

Schema di calcolo iperstatico

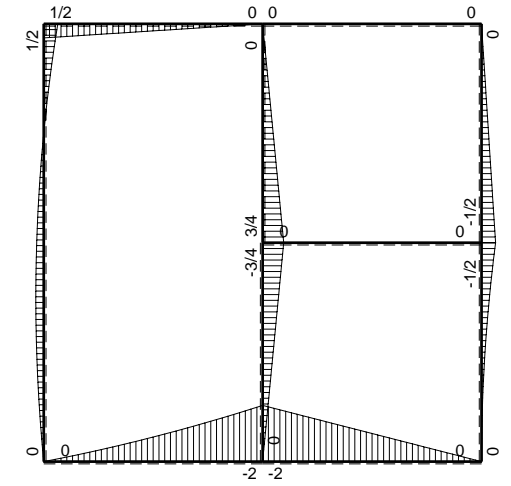

⊕ M₀ flessione da carichi assegnati

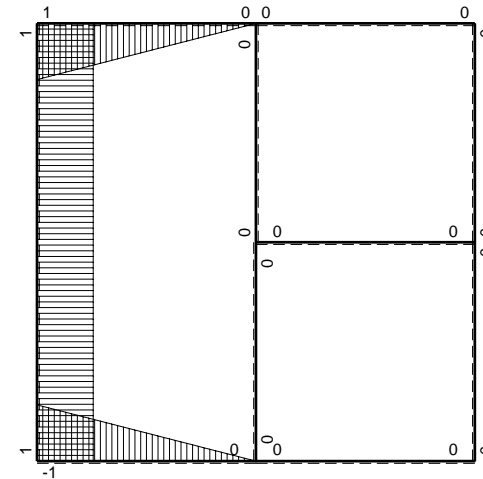

⊕ M_x flessione da iperstatica X=1

Quadro contributi PLV per iperstatica $X=W_{AB}$

→	$M_x(x)$	$M_o(x)$	θ	$M_x M_o$	$M_x \theta$	$M_x M_x$	$\int M_x(M_o/EJ+\theta)dx$	$\int X M_x M_x/EJ dx$
AB b	$-1+x/b$	$-3/2Fx-1/2qx^2$	0	$3/2Fx-Fx^2/b-1/2qx^3/b$	0	$1-2x/b+x^2/b^2$	$(7/24+0)Fb^2/EJ$	$1/3Xb/EJ$
BA b	x/b	$2Fb-5/2Fx+1/2qx^2$	0	$2Fx-5/2Fx^2/b+1/2qx^3/b$	0	x^2/b^2		
BC b	0	$-2Fb+2Fx$	0	0	0	0	0+0	0
CB b	0	$2Fx$	0	0	0	0		
AD 2b	1	$-3/4Fx+1/2qx^2$	0	$-3/4Fx+1/2Fx^2/b$	0	1	$(-1/6+0)Fb^2/EJ$	$2Xb/EJ$
DA 2b	-1	$-1/2Fb+5/4Fx-1/2qx^2$	0	$1/2Fb-5/4Fx+1/2Fx^2/b$	0	1		
DE b	$1-x/b$	$1/2Fb-1/2Fx$	$-Fb/EJ$	$1/2Fb-Fx+1/2Fx^2/b$	$-Fb/EJ+Fx/EJ$	$1-2x/b+x^2/b^2$	$(1/6-1/2)Fb^2/EJ$	$1/3Xb/EJ$
ED b	$-x/b$	$-1/2Fx$	Fb/EJ	$1/2Fx^2/b$	$-Fx/EJ$	x^2/b^2		
EF b	0	0	0	0	0	0	0+0	0
FE b	0	0	0	0	0	0		
FG b	0	$-1/2Fx$	0	0	0	0	0+0	0
GF b	0	$1/2Fb-1/2Fx$	0	0	0	0		
GC b	0	$-1/2Fb+Fx-1/2qx^2$	0	0	0	0	0+0	0
CG b	0	$1/2qx^2$	0	0	0	0		
HG b	0	0	0	0	0	0	0+0	0
GH b	0	0	0	0	0	0		
HB b	0	$-3/4Fb+3/4Fx$	0	0	0	0	0+0	0
BH b	0	$3/4Fx$	0	0	0	0		
HE b	0	$3/4Fb-3/4Fx$	0	0	0	0	0+0	0
EH b	0	$-3/4Fx$	0	0	0	0		
AB	molla asta $-W_{1AB}(W_{0AB}+XW_{1AB})/k_{AB}$							$1/4Xb/EJ$
	totali						$-5/24Fb^2/EJ$	$35/12Xb/EJ$
	iperstatica $X=W_{AB}$						$1/14Fb$	

Sviluppi di calcolo iperstatica

$$L_{AB}^{xx} = \int_0^b (1 - 2x/b + x^2/b^2) \frac{1}{EJ} dx + 1 \cdot \frac{1}{4} \frac{b}{EJ} = \left[x - x^2/b + 1/3 x^3/b^2 \right]_0^b \frac{1}{EJ} + 1 \cdot \frac{1}{4} \frac{b}{EJ}$$

$$= (b - b + 1/3 b) \frac{1}{EJ} + 1 \cdot \frac{1}{4} \frac{b}{EJ} = 7/12 \frac{b}{EJ}$$

$$L_{BA}^{xx} = \int_0^b (x^2/b^2) \frac{1}{EJ} dx + 1 \cdot \frac{1}{4} \frac{b}{EJ} = \left[1/3 x^3/b^2 \right]_0^b \frac{1}{EJ} + 1 \cdot \frac{1}{4} \frac{b}{EJ}$$

$$= (1/3 b) \frac{1}{EJ} + 1 \cdot \frac{1}{4} \frac{b}{EJ} = 7/12 \frac{b}{EJ}$$

$$L_{AD}^{xx} = \int_0^{2b} (1) \frac{1}{EJ} dx = \left[x \right]_0^{2b} \frac{1}{EJ}$$

$$= (2b) \frac{1}{EJ} = 2 \frac{b}{EJ}$$

$$L_{DA}^{xx} = \int_0^{2b} (1) \frac{1}{EJ} dx = \left[x \right]_0^{2b} \frac{1}{EJ}$$

$$= (2b) \frac{1}{EJ} = 2 \frac{b}{EJ}$$

$$L_{DE}^{xx} = \int_0^b (1 - 2x/b + x^2/b^2) \frac{1}{EJ} dx = \left[x - x^2/b + 1/3 x^3/b^2 \right]_0^b \frac{1}{EJ}$$

$$= (b - b + 1/3 b) \frac{1}{EJ} = 1/3 \frac{b}{EJ}$$

$$L_{ED}^{xx} = \int_0^b (x^2/b^2) \frac{1}{EJ} dx = \left[1/3 x^3/b^2 \right]_0^b \frac{1}{EJ}$$

$$= (1/3 b) \frac{1}{EJ} = 1/3 \frac{b}{EJ}$$

$$L_{AB}^{xo} = \int_0^b (3/2 x/b - x^2/b^2 - 1/2 x^3/b^3) Fb \frac{1}{EJ} dx + 1 \cdot 0 \cdot \frac{1}{4} \frac{Fb^2}{EJ}$$

$$= \left[3/4 x^2/b - 1/3 x^3/b^2 - 1/8 x^4/b^3 \right]_0^b Fb \frac{1}{EJ} + 1 \cdot 0 \cdot \frac{1}{4} \frac{Fb^2}{EJ}$$

$$= (3/4 b - 1/3 b - 1/8 b) Fb \frac{1}{EJ} + 1 \cdot 0 \cdot \frac{1}{4} \frac{Fb^2}{EJ} = 7/24 \frac{Fb^2}{EJ}$$

$$L_{BA}^{xo} = \int_0^b (2x/b - 5/2 x^2/b^2 + 1/2 x^3/b^3) Fb \frac{1}{EJ} dx + 1 \cdot 0 \cdot \frac{1}{4} \frac{Fb^2}{EJ}$$

$$= \left[x^2/b - 5/6 x^3/b^2 + 1/8 x^4/b^3 \right]_0^b Fb \frac{1}{EJ} + 1 \cdot 0 \cdot \frac{1}{4} \frac{Fb^2}{EJ}$$

$$= (b - 5/6 b + 1/8 b) Fb \frac{1}{EJ} + 1 \cdot 0 \cdot \frac{1}{4} \frac{Fb^2}{EJ} = 7/24 \frac{Fb^2}{EJ}$$

$$L_{AD}^{xo} = \int_0^{2b} (-3/4 x/b + 1/2 x^2/b^2) Fb \frac{1}{EJ} dx = \left[-3/8 x^2/b + 1/6 x^3/b^2 \right]_0^{2b} Fb \frac{1}{EJ}$$

$$= (-3/2 b + 4/3 b) Fb \frac{1}{EJ} = -1/6 \frac{Fb^2}{EJ}$$

$$L_{DA}^{xo} = \int_0^{2b} (1/2 - 5/4 x/b + 1/2 x^2/b^2) Fb \frac{1}{EJ} dx = \left[1/2 x - 5/8 x^2/b + 1/6 x^3/b^2 \right]_0^{2b} Fb \frac{1}{EJ}$$

$$= (b - 5/2 b + 4/3 b) Fb \frac{1}{EJ} = -1/6 \frac{Fb^2}{EJ}$$

$$L_{DE}^{xo} = \int_0^b (1/2 - x/b + 1/2 x^2/b^2) Fb \frac{1}{EJ} dx + \int_0^b (-1 + x/b) \theta dx$$

$$= \left[1/2 x - 1/2 x^2/b + 1/6 x^3/b^2 \right]_0^b Fb \frac{1}{EJ} + \left[-x + 1/2 x^2/b \right]_0^b \theta$$

$$= (1/2 b - 1/2 b + 1/6 b) Fb \frac{1}{EJ} + (-b + 1/2 b) \theta = -1/3 \frac{Fb^2}{EJ}$$

$$L_{ED}^{xo} = \int_0^b (1/2 x^2/b^2) Fb \frac{1}{EJ} dx + \int_0^b (x/b) \theta dx = \left[1/6 x^3/b^2 \right]_0^b Fb \frac{1}{EJ} + \left[1/2 x^2/b \right]_0^b \theta$$

$$= (1/6 b) Fb \frac{1}{EJ} + (1/2 b) \theta = -1/3 \frac{Fb^2}{EJ}$$

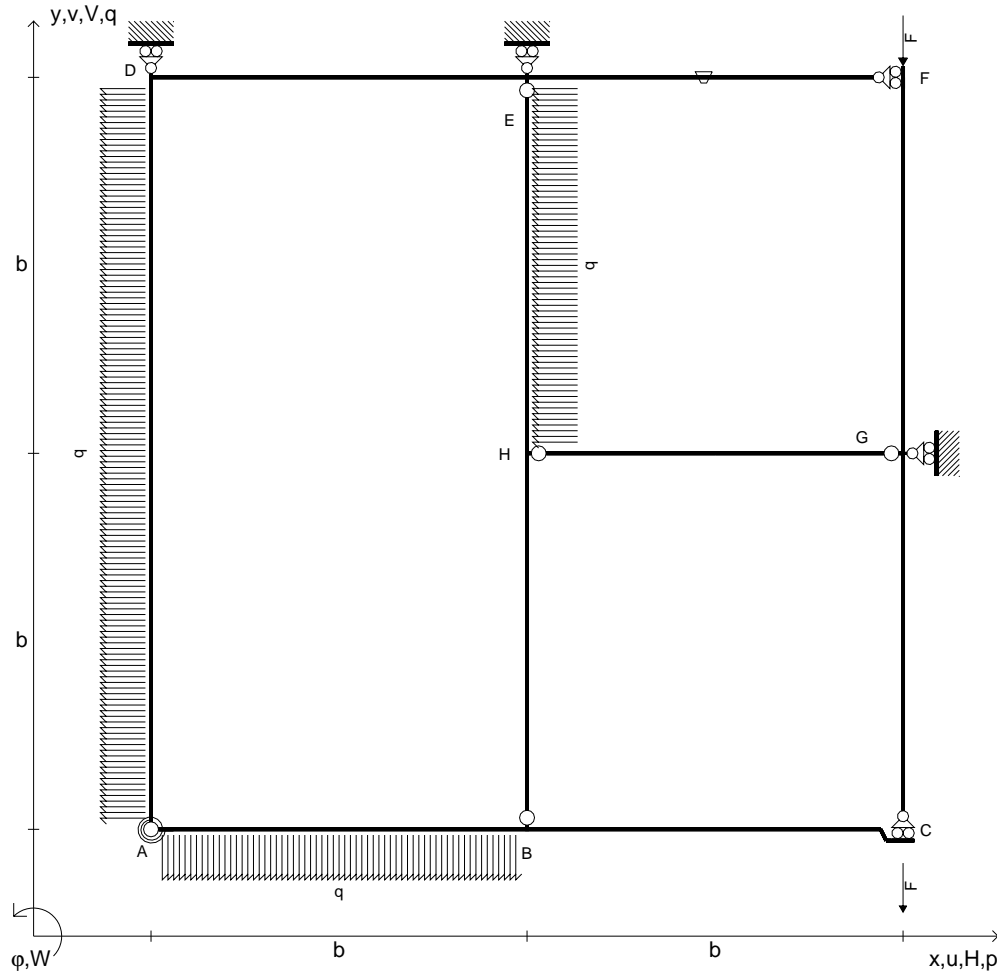

$V_{FG} = -F$	$k_{AB} = 4EJ/b$	$EJ_{FG} = EJ$
$V_{CB} = -F$	$EJ_{AB} = EJ$	$EJ_{GC} = EJ$
$q_{AB} = -q = -F/b$	$EJ_{BC} = EJ$	$EJ_{HG} = EJ$
$p_{AD} = -q = -F/b$	$EJ_{AD} = EJ$	$EJ_{HB} = EJ$
$p_{HE} = -q = -F/b$	$EJ_{DE} = EJ$	$EJ_{HE} = EJ$
$\theta_{EF} = -\theta = -\alpha T/b = -bF/EJ$	$EJ_{EF} = EJ$	

Reazioni iperstatiche in soluzione: $X=W_{AB}$
 Carichi e deformazioni date hanno verso efficace in disegno.
 Calcolare reazioni vincolari della struttura e delle aste.
 Tracciare i diagrammi quotati delle azioni interne nelle aste.
 $J_{YZ} - x_{YZ} - \theta_{YZ}$ riferimento locale asta YZ con origine in Y.
 Curvatura θ asta EF positiva se convessa a destra con inizio E.
 © Adolfo Zavelani Rossi, Politecnico di Milano, vers.27.03.13

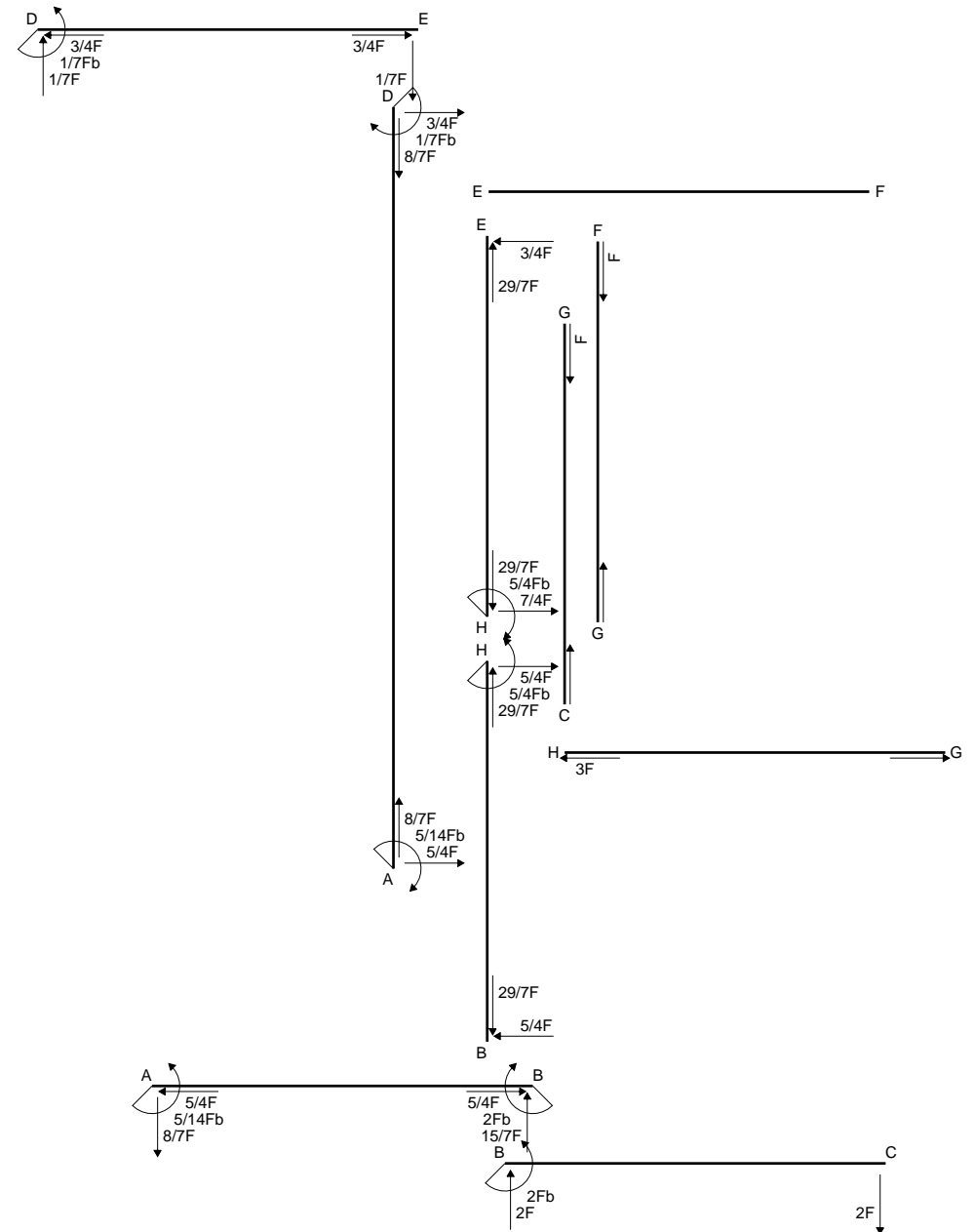

Quadro contributi PLV per iperstatica $X=W_{AB}$

→	$M_x(x)$	$M_o(x)$	θ	$M_x M_o$	$M_x \theta$	$M_x M_x$	$\int M_x(M_o/EJ+\theta)dx$	$\int X M_x M_x/EJ dx$
AB b	$-1+x/b$	$-3/2Fx-1/2qx^2$	0	$3/2Fx-Fx^2/b-1/2qx^3/b$	0	$1-2x/b+x^2/b^2$	$(7/24+0)Fb^2/EJ$	$1/3Xb/EJ$
BA b	x/b	$2Fb-5/2Fx+1/2qx^2$	0	$2Fx-5/2Fx^2/b+1/2qx^3/b$	0	x^2/b^2		
BC b	0	$-2Fb+2Fx$	0	0	0	0	0+0	0
CB b	0	$2Fx$	0	0	0	0		
AD 2b	1	$-5/4Fx+1/2qx^2$	0	$-5/4Fx+1/2Fx^2/b$	0	1	$(-7/6+0)Fb^2/EJ$	$2Xb/EJ$
DA 2b	-1	$1/2Fb+3/4Fx-1/2qx^2$	0	$-1/2Fb-3/4Fx+1/2Fx^2/b$	0	1		
DE b	$1-x/b$	$-1/2Fb+1/2Fx$	0	$-1/2Fb+Fx-1/2Fx^2/b$	0	$1-2x/b+x^2/b^2$	$(-1/6+0)Fb^2/EJ$	$1/3Xb/EJ$
ED b	$-x/b$	$1/2Fx$	0	$-1/2Fx^2/b$	0	x^2/b^2		
EF b	0	0	$-Fb/EJ$	0	0	0	0+0	0
FE b	0	0	Fb/EJ	0	0	0		
FG b	0	0	0	0	0	0	0+0	0
GF b	0	0	0	0	0	0		
GC b	0	0	0	0	0	0	0+0	0
CG b	0	0	0	0	0	0		
HG b	0	0	0	0	0	0	0+0	0
GH b	0	0	0	0	0	0		
HB b	0	$-5/4Fb+5/4Fx$	0	0	0	0	0+0	0
BH b	0	$5/4Fx$	0	0	0	0		
HE b	0	$5/4Fb-7/4Fx+1/2qx^2$	0	0	0	0	0+0	0
EH b	0	$-3/4Fx-1/2qx^2$	0	0	0	0		
AB	molla asta $-W_{1AB}(W_{0AB}+XW_{1AB})/k_{AB}$							$1/4Xb/EJ$
	totali						$-25/24Fb^2/EJ$	$35/12Xb/EJ$
	iperstatica $X=W_{AB}$						$5/14Fb$	

Sviluppi di calcolo iperstatica

$$L_{AB}^{xx} = \int_0^b (1 - 2x/b + x^2/b^2) \cdot 1/EJ \, dx + 1 \cdot 1/4 \cdot b/EJ = \left[x - x^2/b + 1/3 x^3/b^2 \right]_0^b \cdot 1/EJ + 1 \cdot 1/4 \cdot b/EJ$$

$$= (b - b + 1/3 b) \cdot 1/EJ + 1 \cdot 1/4 \cdot b/EJ = 7/12 \cdot b/EJ$$

$$L_{BA}^{xx} = \int_0^b (x^2/b^2) \cdot 1/EJ \, dx + 1 \cdot 1/4 \cdot b/EJ = \left[1/3 x^3/b^2 \right]_0^b \cdot 1/EJ + 1 \cdot 1/4 \cdot b/EJ$$

$$= (1/3 b) \cdot 1/EJ + 1 \cdot 1/4 \cdot b/EJ = 7/12 \cdot b/EJ$$

$$L_{AD}^{xx} = \int_0^{2b} (1) \cdot 1/EJ \, dx = \left[x \right]_0^{2b} \cdot 1/EJ$$

$$= (2b) \cdot 1/EJ = 2 \cdot b/EJ$$

$$L_{DA}^{xx} = \int_0^{2b} (1) \cdot 1/EJ \, dx = \left[x \right]_0^{2b} \cdot 1/EJ$$

$$= (2b) \cdot 1/EJ = 2 \cdot b/EJ$$

$$L_{DE}^{xx} = \int_0^b (1 - 2x/b + x^2/b^2) \cdot 1/EJ \, dx = \left[x - x^2/b + 1/3 x^3/b^2 \right]_0^b \cdot 1/EJ$$

$$= (b - b + 1/3 b) \cdot 1/EJ = 1/3 \cdot b/EJ$$

$$L_{ED}^{xx} = \int_0^b (x^2/b^2) \cdot 1/EJ \, dx = \left[1/3 x^3/b^2 \right]_0^b \cdot 1/EJ$$

$$= (1/3 b) \cdot 1/EJ = 1/3 \cdot b/EJ$$

$$L_{AB}^{xo} = \int_0^b (3/2 x/b - x^2/b^2 - 1/2 x^3/b^3) \cdot Fb \cdot 1/EJ \, dx + 1 \cdot 0 \cdot 1/4 \cdot Fb^2/EJ$$

$$= \left[3/4 x^2/b - 1/3 x^3/b^2 - 1/8 x^4/b^3 \right]_0^b \cdot Fb \cdot 1/EJ + 1 \cdot 0 \cdot 1/4 \cdot Fb^2/EJ$$

$$= (3/4 b - 1/3 b - 1/8 b) \cdot Fb \cdot 1/EJ + 1 \cdot 0 \cdot 1/4 \cdot Fb^2/EJ = 7/24 \cdot Fb^2/EJ$$

$$L_{BA}^{xo} = \int_0^b (2x/b - 5/2 x^2/b^2 + 1/2 x^3/b^3) \cdot Fb \cdot 1/EJ \, dx + 1 \cdot 0 \cdot 1/4 \cdot Fb^2/EJ$$

$$= \left[x^2/b - 5/6 x^3/b^2 + 1/8 x^4/b^3 \right]_0^b \cdot Fb \cdot 1/EJ + 1 \cdot 0 \cdot 1/4 \cdot Fb^2/EJ$$

$$= (b - 5/6 b + 1/8 b) \cdot Fb \cdot 1/EJ + 1 \cdot 0 \cdot 1/4 \cdot Fb^2/EJ = 7/24 \cdot Fb^2/EJ$$

$$L_{AD}^{xo} = \int_0^{2b} (-5/4 x/b + 1/2 x^2/b^2) \cdot Fb \cdot 1/EJ \, dx = \left[-5/8 x^2/b + 1/6 x^3/b^2 \right]_0^{2b} \cdot Fb \cdot 1/EJ$$

$$= (-5/2 b + 4/3 b) \cdot Fb \cdot 1/EJ = -7/6 \cdot Fb^2/EJ$$

$$L_{DA}^{xo} = \int_0^{2b} (-1/2 - 3/4 x/b + 1/2 x^2/b^2) \cdot Fb \cdot 1/EJ \, dx = \left[-1/2 x - 3/8 x^2/b + 1/6 x^3/b^2 \right]_0^{2b} \cdot Fb \cdot 1/EJ$$

$$= (-b - 3/2 b + 4/3 b) \cdot Fb \cdot 1/EJ = -7/6 \cdot Fb^2/EJ$$

$$L_{DE}^{xo} = \int_0^b (-1/2 + x/b - 1/2 x^2/b^2) \cdot Fb \cdot 1/EJ \, dx = \left[-1/2 x + 1/2 x^2/b - 1/6 x^3/b^2 \right]_0^b \cdot Fb \cdot 1/EJ$$

$$= (-1/2 b + 1/2 b - 1/6 b) \cdot Fb \cdot 1/EJ = -1/6 \cdot Fb^2/EJ$$

$$L_{ED}^{xo} = \int_0^b (-1/2 x^2/b^2) \cdot Fb \cdot 1/EJ \, dx = \left[-1/6 x^3/b^2 \right]_0^b \cdot Fb \cdot 1/EJ$$

$$= (-1/6 b) \cdot Fb \cdot 1/EJ = -1/6 \cdot Fb^2/EJ$$

Quadro contributi PLV per iperstatica $X=W_{DE}$

→	$M_x(x)$	$M_o(x)$	θ	$M_x M_o$	$M_x \theta$	$M_x M_x$	$\int M_x(M_o/EJ+\theta)dx$	$\int X M_x M_x/EJdx$	
AB b	$1-x/b$	$-2Fx-1/2qx^2$	0	$-2Fx+3/2Fx^2/b+1/2qx^3/b$	0	$1-2x/b+x^2/b^2$	$(-3/8+0)Fb^2/EJ$	$1/3Xb/EJ$	
BA b	$-x/b$	$5/2Fb-3Fx+1/2qx^2$	0	$-5/2Fx+3Fx^2/b-1/2qx^3/b$	0	x^2/b^2			
BC b	0	$-5/2Fb+5/2Fx$	0	0	0	0	0+0	0	
CB b	0	$5/2Fx$	0	0	0	0			
AD 2b	-1	$-Fx+1/2qx^2$	0	$Fx-1/2Fx^2/b$	0	1	$(2/3+0)Fb^2/EJ$	$2Xb/EJ$	
DA 2b	1	$Fx-1/2qx^2$	0	$Fx-1/2Fx^2/b$	0	1			
DE b	$-1+x/b$	0	0	0	0	$1-2x/b+x^2/b^2$	0+0	$1/3Xb/EJ$	
ED b	x/b	0	0	0	0	x^2/b^2			
EF b	0	0	0	0	0	0	0+0	0	
FE b	0	0	0	0	0	0			
FG b	0	0	0	0	0	0	0+0	0	
GF b	0	0	0	0	0	0			
GC b	0	0	0	0	0	0	0+0	0	
CG b	0	0	0	0	0	0			
HG b	0	$1/2Fx-1/2qx^2$	0	0	0	0	0+0	0	
GH b	0	$-1/2Fx+1/2qx^2$	0	0	0	0			
HB b	0	$-Fb+Fx$	0	0	0	0	0+0	0	
BH b	0	Fx	0	0	0	0			
HE b	0	$Fb-Fx$	$-Fb/EJ$	0	0	0	0+0	0	
EH b	0	$-Fx$	Fb/EJ	0	0	0			
AB	molla asta $-W_{1AB}(W_{0AB}+XW_{1AB})/k_{AB}$								$1/4Xb/EJ$
	totali							$7/24Fb^2/EJ$	$35/12Xb/EJ$
	iperstatica $X=W_{DE}$							$-1/10Fb$	

Sviluppi di calcolo iperstatica

$$L_{AB}^{xx} = \int_0^b (1 - 2x/b + x^2/b^2) \cdot 1/EJ \, dx - 1 \cdot (-1) \cdot 1/4 \cdot b/EJ = \left[x - x^2/b + 1/3 x^3/b^2 \right]_0^b \cdot 1/EJ - 1 \cdot (-1) \cdot 1/4 \cdot b/EJ$$

$$= (b - b + 1/3 b) \cdot 1/EJ - 1 \cdot (-1) \cdot 1/4 \cdot b/EJ = 7/12 \cdot b/EJ$$

$$L_{BA}^{xx} = \int_0^b (x^2/b^2) \cdot 1/EJ \, dx - 1 \cdot (-1) \cdot 1/4 \cdot b/EJ = \left[1/3 x^3/b^2 \right]_0^b \cdot 1/EJ - 1 \cdot (-1) \cdot 1/4 \cdot b/EJ$$

$$= (1/3 b) \cdot 1/EJ - 1 \cdot (-1) \cdot 1/4 \cdot b/EJ = 7/12 \cdot b/EJ$$

$$L_{AD}^{xx} = \int_0^{2b} (1) \cdot 1/EJ \, dx = \left[x \right]_0^{2b} \cdot 1/EJ$$

$$= (2b) \cdot 1/EJ = 2 \cdot b/EJ$$

$$L_{DA}^{xx} = \int_0^{2b} (1) \cdot 1/EJ \, dx = \left[x \right]_0^{2b} \cdot 1/EJ$$

$$= (2b) \cdot 1/EJ = 2 \cdot b/EJ$$

$$L_{DE}^{xx} = \int_0^b (1 - 2x/b + x^2/b^2) \cdot 1/EJ \, dx = \left[x - x^2/b + 1/3 x^3/b^2 \right]_0^b \cdot 1/EJ$$

$$= (b - b + 1/3 b) \cdot 1/EJ = 1/3 \cdot b/EJ$$

$$L_{ED}^{xx} = \int_0^b (x^2/b^2) \cdot 1/EJ \, dx = \left[1/3 x^3/b^2 \right]_0^b \cdot 1/EJ$$

$$= (1/3 b) \cdot 1/EJ = 1/3 \cdot b/EJ$$

$$L_{AB}^{xo} = \int_0^b (-2x/b + 3/2 x^2/b^2 + 1/2 x^3/b^3) \cdot Fb \cdot 1/EJ \, dx - 1 \cdot 0 \cdot 1/4 \cdot Fb^2/EJ$$

$$= \left[-x^2/b + 1/2 x^3/b^2 + 1/8 x^4/b^3 \right]_0^b \cdot Fb \cdot 1/EJ - 1 \cdot 0 \cdot 1/4 \cdot Fb^2/EJ$$

$$= (-b + 1/2 b + 1/8 b) \cdot Fb \cdot 1/EJ - 1 \cdot 0 \cdot 1/4 \cdot Fb^2/EJ = -3/8 \cdot Fb^2/EJ$$

$$L_{BA}^{xo} = \int_0^b (-5/2 x/b + 3 x^2/b^2 - 1/2 x^3/b^3) \cdot Fb \cdot 1/EJ \, dx - 1 \cdot 0 \cdot 1/4 \cdot Fb^2/EJ$$

$$= \left[-5/4 x^2/b + x^3/b^2 - 1/8 x^4/b^3 \right]_0^b \cdot Fb \cdot 1/EJ - 1 \cdot 0 \cdot 1/4 \cdot Fb^2/EJ$$

$$= (-5/4 b + b - 1/8 b) \cdot Fb \cdot 1/EJ - 1 \cdot 0 \cdot 1/4 \cdot Fb^2/EJ = -3/8 \cdot Fb^2/EJ$$

$$L_{AD}^{xo} = \int_0^{2b} (x/b - 1/2 x^2/b^2) \cdot Fb \cdot 1/EJ \, dx = \left[1/2 x^2/b - 1/6 x^3/b^2 \right]_0^{2b} \cdot Fb \cdot 1/EJ$$

$$= (2b - 4/3 b) \cdot Fb \cdot 1/EJ = 2/3 \cdot Fb^2/EJ$$

$$L_{DA}^{xo} = \int_0^{2b} (x/b - 1/2 x^2/b^2) \cdot Fb \cdot 1/EJ \, dx = \left[1/2 x^2/b - 1/6 x^3/b^2 \right]_0^{2b} \cdot Fb \cdot 1/EJ$$

$$= (2b - 4/3 b) \cdot Fb \cdot 1/EJ = 2/3 \cdot Fb^2/EJ$$

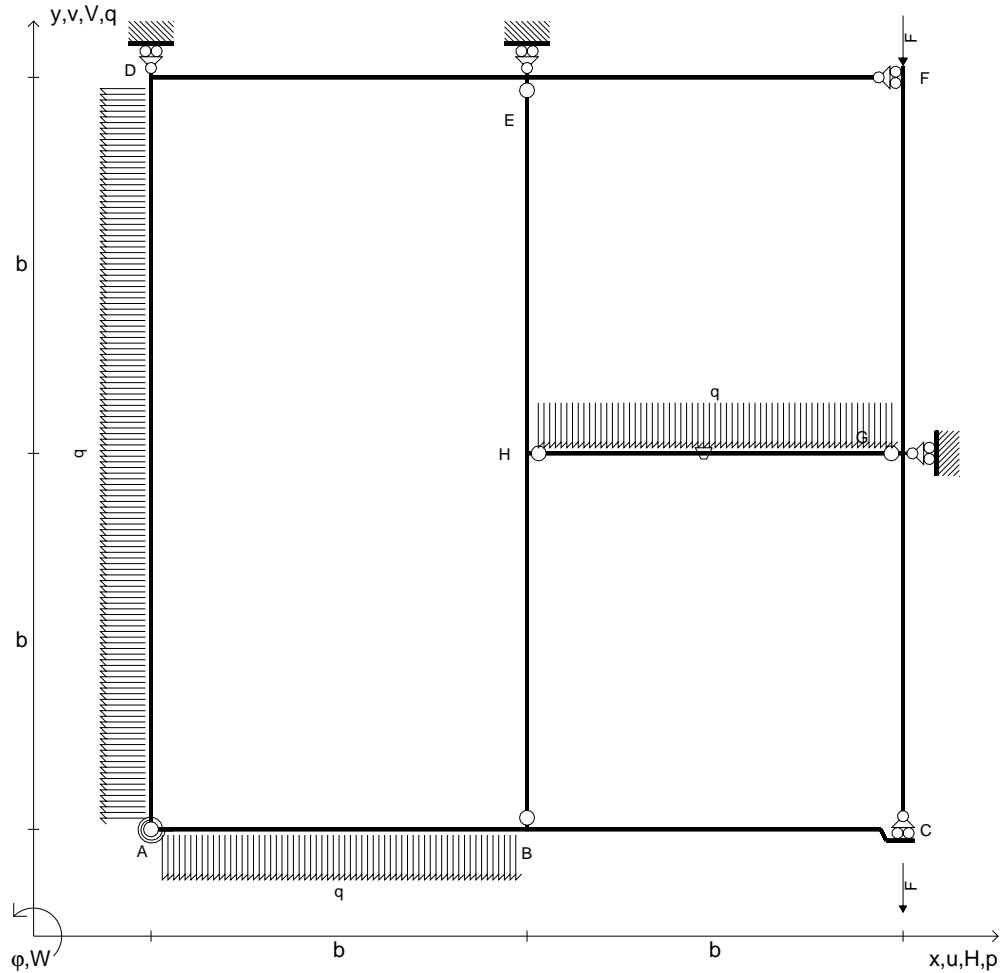

$V_{FG} = -F$	$k_{AB} = 4EJ/b$	$EJ_{FG} = EJ$
$V_{CB} = -F$	$EJ_{AB} = EJ$	$EJ_{GC} = EJ$
$q_{AB} = -q = -F/b$	$EJ_{BC} = EJ$	$EJ_{HG} = EJ$
$p_{AD} = -q = -F/b$	$EJ_{AD} = EJ$	$EJ_{HB} = EJ$
$q_{HG} = -q = -F/b$	$EJ_{DE} = EJ$	$EJ_{HE} = EJ$
$\theta_{HG} = -\theta = -\alpha T/b = -bF/EJ$	$EJ_{EF} = EJ$	

Reazioni iperstatiche in soluzione: $X=W_{DE}$
 Carichi e deformazioni date hanno verso efficace in disegno.
 Calcolare reazioni vincolari della struttura e delle aste.
 Tracciare i diagrammi quotati delle azioni interne nelle aste.
 $J_{YZ} - x_{YZ} - \theta_{YZ}$ riferimento locale asta YZ con origine in Y.
 Curvatura θ asta HG positiva se convessa a destra con inizio H.
 © Adolfo Zavelani Rossi, Politecnico di Milano, vers.27.03.13

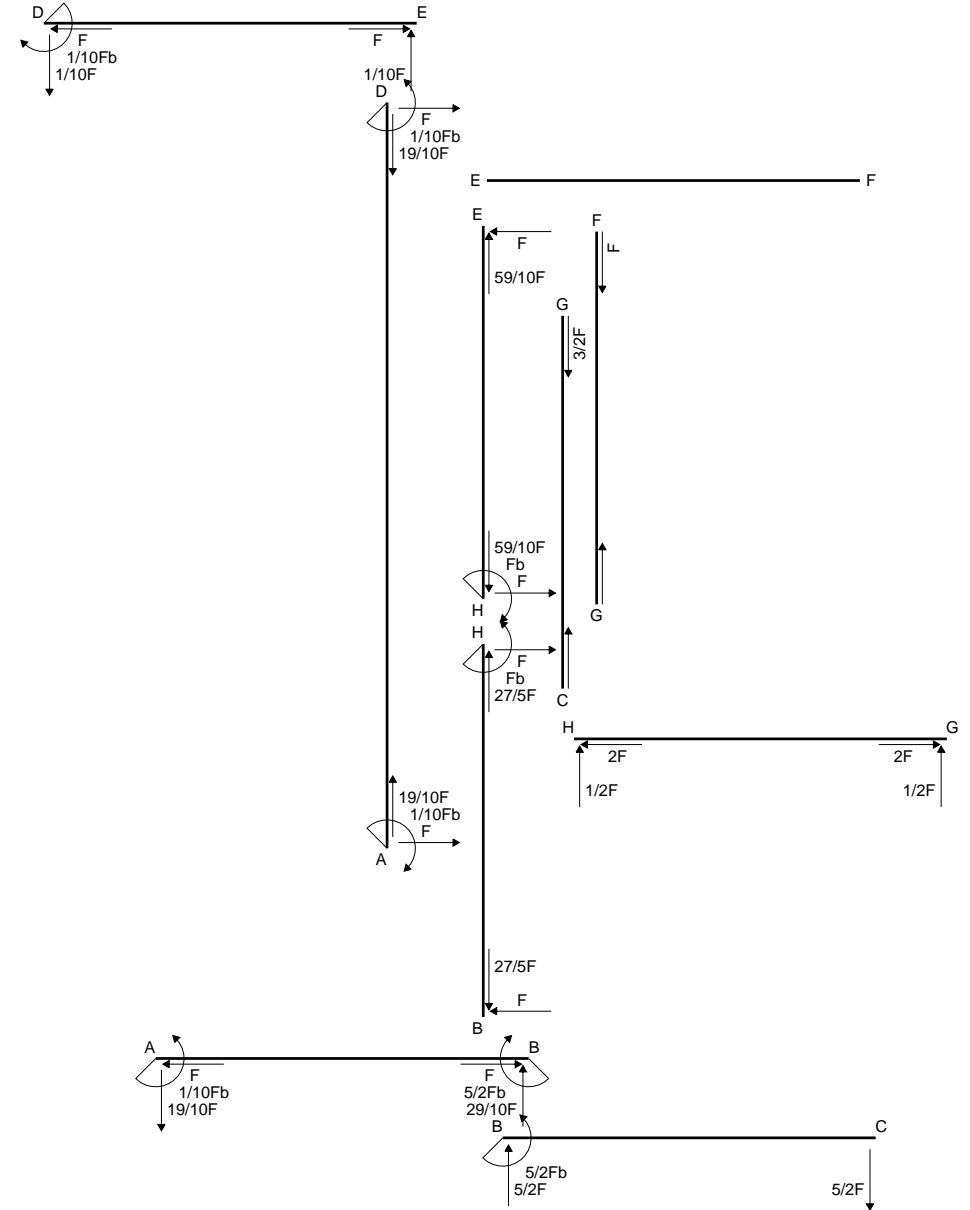

Quadro contributi PLV per iperstatica $X=W_{DE}$

→	$M_x(x)$	$M_o(x)$	θ	$M_x M_o$	$M_x \theta$	$M_x M_x$	$\int M_x(M_o/EJ+\theta)dx$	$\int X M_x M_x/EJ dx$	
AB b	$1-x/b$	$-2Fx-1/2qx^2$	0	$-2Fx+3/2Fx^2/b+1/2qx^3/b$	0	$1-2x/b+x^2/b^2$	$(-3/8+0)Fb^2/EJ$	$1/3Xb/EJ$	
BA b	$-x/b$	$5/2Fb-3Fx+1/2qx^2$	0	$-5/2Fx+3Fx^2/b-1/2qx^3/b$	0	x^2/b^2			
BC b	0	$-5/2Fb+5/2Fx$	0	0	0	0	0+0	0	
CB b	0	$5/2Fx$	0	0	0	0			
AD 2b	-1	$-Fx+1/2qx^2$	0	$Fx-1/2Fx^2/b$	0	1	$(2/3+0)Fb^2/EJ$	$2Xb/EJ$	
DA 2b	1	$Fx-1/2qx^2$	0	$Fx-1/2Fx^2/b$	0	1			
DE b	$-1+x/b$	0	0	0	0	$1-2x/b+x^2/b^2$	0+0	$1/3Xb/EJ$	
ED b	x/b	0	0	0	0	x^2/b^2			
EF b	0	0	0	0	0	0	0+0	0	
FE b	0	0	0	0	0	0			
FG b	0	0	0	0	0	0	0+0	0	
GF b	0	0	0	0	0	0			
GC b	0	0	0	0	0	0	0+0	0	
CG b	0	0	0	0	0	0			
HG b	0	$1/2Fx-1/2qx^2$	$-Fb/EJ$	0	0	0	0+0	0	
GH b	0	$-1/2Fx+1/2qx^2$	Fb/EJ	0	0	0			
HB b	0	$-Fb+Fx$	0	0	0	0	0+0	0	
BH b	0	Fx	0	0	0	0			
HE b	0	$Fb-Fx$	0	0	0	0	0+0	0	
EH b	0	$-Fx$	0	0	0	0			
AB	molla asta $-W_{1AB}(W_{0AB}+XW_{1AB})/k_{AB}$								$1/4Xb/EJ$
	totali							$7/24Fb^2/EJ$	$35/12Xb/EJ$
	iperstatica $X=W_{DE}$							$-1/10Fb$	

Sviluppi di calcolo iperstatica

$$L_{AB}^{xx} = \int_0^b (1 - 2x/b + x^2/b^2) \cdot 1/EJ \, dx - 1 \cdot (-1) \cdot 1/4 \cdot b/EJ = \left[x - x^2/b + 1/3 x^3/b^2 \right]_0^b \cdot 1/EJ - 1 \cdot (-1) \cdot 1/4 \cdot b/EJ$$

$$= (b - b + 1/3 b) \cdot 1/EJ - 1 \cdot (-1) \cdot 1/4 \cdot b/EJ = 7/12 \cdot b/EJ$$

$$L_{BA}^{xx} = \int_0^b (x^2/b^2) \cdot 1/EJ \, dx - 1 \cdot (-1) \cdot 1/4 \cdot b/EJ = \left[1/3 x^3/b^2 \right]_0^b \cdot 1/EJ - 1 \cdot (-1) \cdot 1/4 \cdot b/EJ$$

$$= (1/3 b) \cdot 1/EJ - 1 \cdot (-1) \cdot 1/4 \cdot b/EJ = 7/12 \cdot b/EJ$$

$$L_{AD}^{xx} = \int_0^{2b} (1) \cdot 1/EJ \, dx = \left[x \right]_0^{2b} \cdot 1/EJ$$

$$= (2b) \cdot 1/EJ = 2 \cdot b/EJ$$

$$L_{DA}^{xx} = \int_0^{2b} (1) \cdot 1/EJ \, dx = \left[x \right]_0^{2b} \cdot 1/EJ$$

$$= (2b) \cdot 1/EJ = 2 \cdot b/EJ$$

$$L_{DE}^{xx} = \int_0^b (1 - 2x/b + x^2/b^2) \cdot 1/EJ \, dx = \left[x - x^2/b + 1/3 x^3/b^2 \right]_0^b \cdot 1/EJ$$

$$= (b - b + 1/3 b) \cdot 1/EJ = 1/3 \cdot b/EJ$$

$$L_{ED}^{xx} = \int_0^b (x^2/b^2) \cdot 1/EJ \, dx = \left[1/3 x^3/b^2 \right]_0^b \cdot 1/EJ$$

$$= (1/3 b) \cdot 1/EJ = 1/3 \cdot b/EJ$$

$$L_{AB}^{xo} = \int_0^b (-2x/b + 3/2 x^2/b^2 + 1/2 x^3/b^3) \cdot Fb \cdot 1/EJ \, dx - 1 \cdot 0 \cdot 1/4 \cdot Fb^2/EJ$$

$$= \left[-x^2/b + 1/2 x^3/b^2 + 1/8 x^4/b^3 \right]_0^b \cdot Fb \cdot 1/EJ - 1 \cdot 0 \cdot 1/4 \cdot Fb^2/EJ$$

$$= (-b + 1/2 b + 1/8 b) \cdot Fb \cdot 1/EJ - 1 \cdot 0 \cdot 1/4 \cdot Fb^2/EJ = -3/8 \cdot Fb^2/EJ$$

$$L_{BA}^{xo} = \int_0^b (-5/2 x/b + 3 x^2/b^2 - 1/2 x^3/b^3) \cdot Fb \cdot 1/EJ \, dx - 1 \cdot 0 \cdot 1/4 \cdot Fb^2/EJ$$

$$= \left[-5/4 x^2/b + x^3/b^2 - 1/8 x^4/b^3 \right]_0^b \cdot Fb \cdot 1/EJ - 1 \cdot 0 \cdot 1/4 \cdot Fb^2/EJ$$

$$= (-5/4 b + b - 1/8 b) \cdot Fb \cdot 1/EJ - 1 \cdot 0 \cdot 1/4 \cdot Fb^2/EJ = -3/8 \cdot Fb^2/EJ$$

$$L_{AD}^{xo} = \int_0^{2b} (x/b - 1/2 x^2/b^2) \cdot Fb \cdot 1/EJ \, dx = \left[1/2 x^2/b - 1/6 x^3/b^2 \right]_0^{2b} \cdot Fb \cdot 1/EJ$$

$$= (2b - 4/3 b) \cdot Fb \cdot 1/EJ = 2/3 \cdot Fb^2/EJ$$

$$L_{DA}^{xo} = \int_0^{2b} (x/b - 1/2 x^2/b^2) \cdot Fb \cdot 1/EJ \, dx = \left[1/2 x^2/b - 1/6 x^3/b^2 \right]_0^{2b} \cdot Fb \cdot 1/EJ$$

$$= (2b - 4/3 b) \cdot Fb \cdot 1/EJ = 2/3 \cdot Fb^2/EJ$$

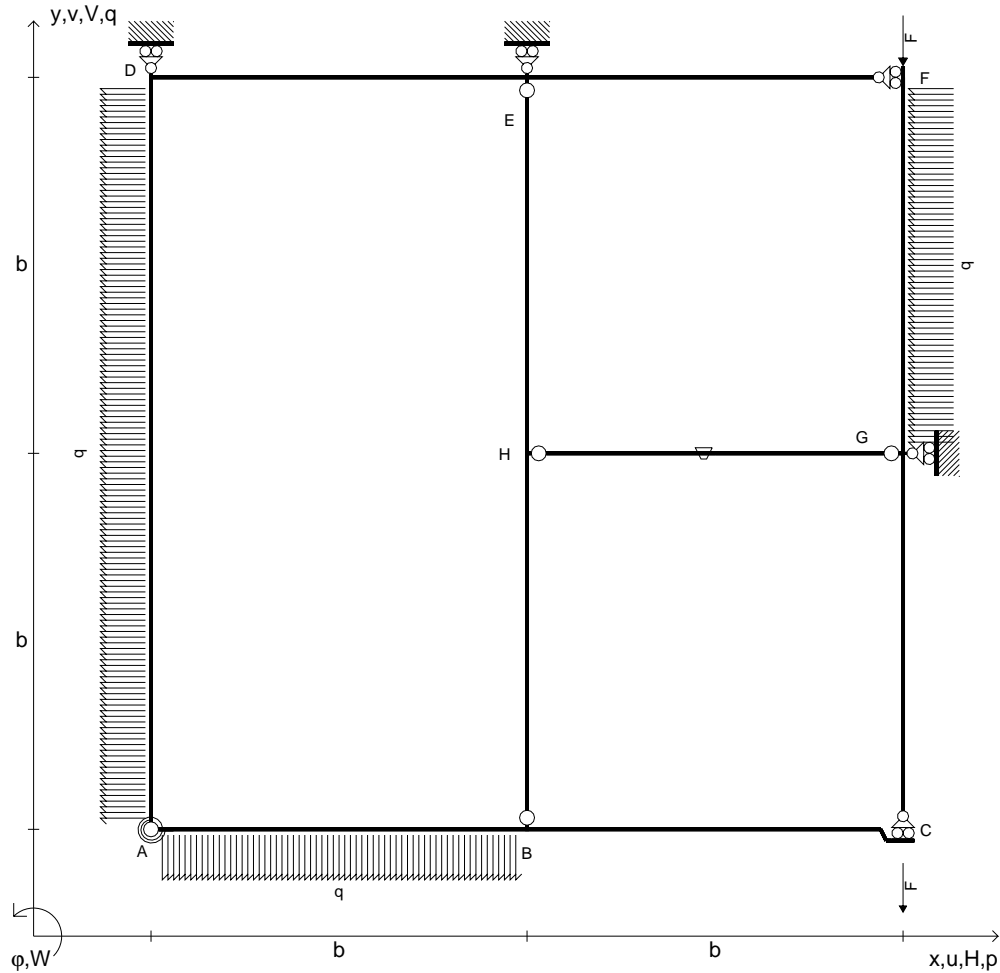

$V_{FG} = -F$	$k_{AB} = 4EJ/b$	$EJ_{FG} = EJ$
$V_{CB} = -F$	$EJ_{AB} = EJ$	$EJ_{GC} = EJ$
$q_{AB} = -q = -F/b$	$EJ_{BC} = EJ$	$EJ_{HG} = EJ$
$p_{AD} = -q = -F/b$	$EJ_{AD} = EJ$	$EJ_{HB} = EJ$
$p_{FG} = -q = -F/b$	$EJ_{DE} = EJ$	$EJ_{HE} = EJ$
$\theta_{HG} = -\theta = -\alpha T/b = -bF/EJ$	$EJ_{EF} = EJ$	

Reazioni iperstatiche in soluzione: $X=W_{AD}$

Carichi e deformazioni date hanno verso efficace in disegno.

Calcolare reazioni vincolari della struttura e delle aste.

Tracciare i diagrammi quotati delle azioni interne nelle aste.

$J_{YZ} - x_{YZ} - \theta_{YZ}$ riferimento locale asta YZ con origine in Y.

Curvatura θ asta HG positiva se convessa a destra con inizio H.

@ Adolfo Zavelani Rossi, Politecnico di Milano, vers.27.03.13

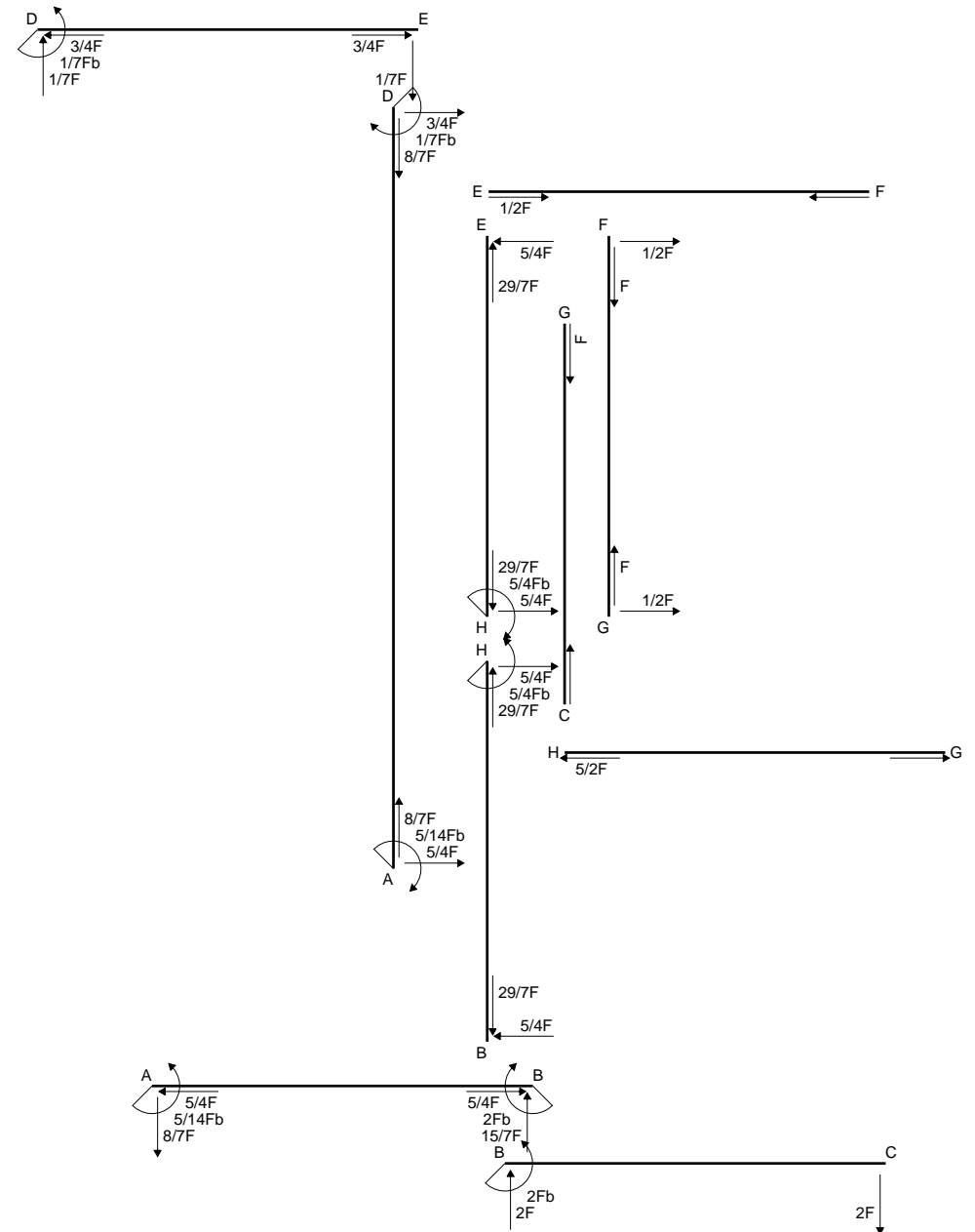

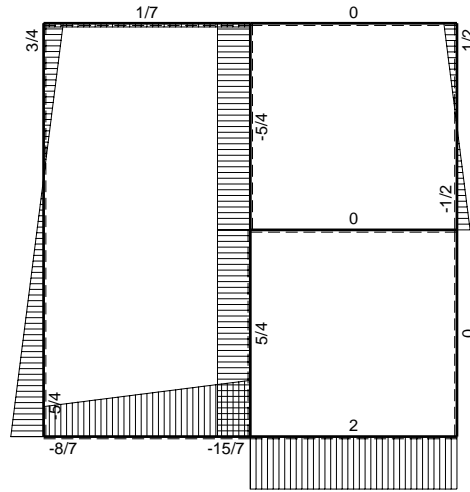
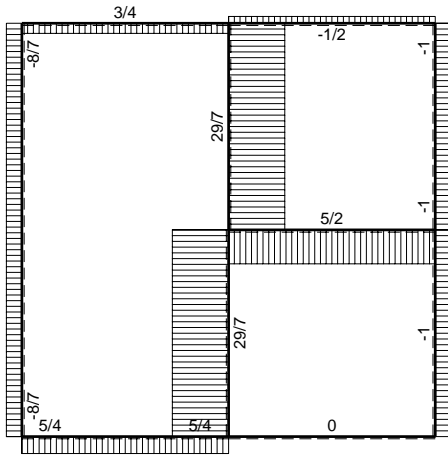

← (+) → F

↑ (+) ↓ F

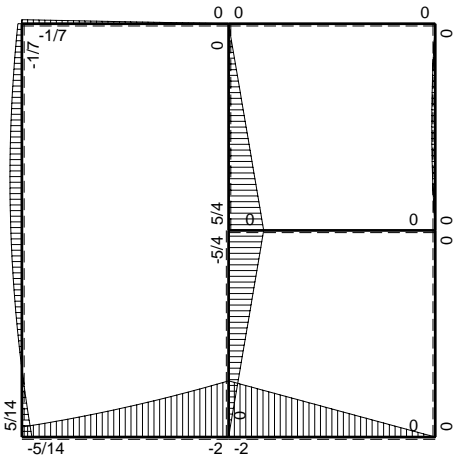

⊞ (+) ⊞ Fb

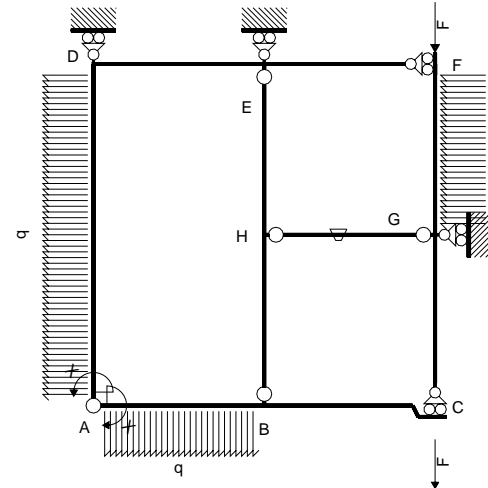

Schema di calcolo iperstatico

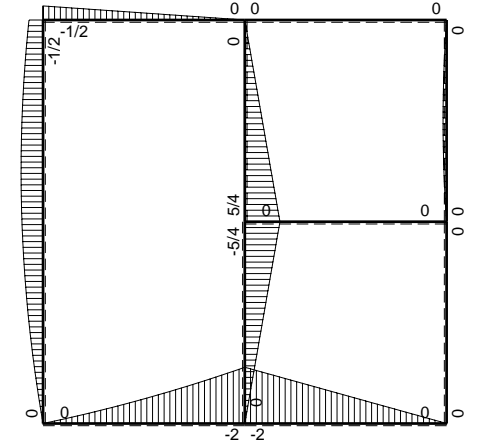

⊞ (+) ⊞ Mo flessione da carichi assegnati

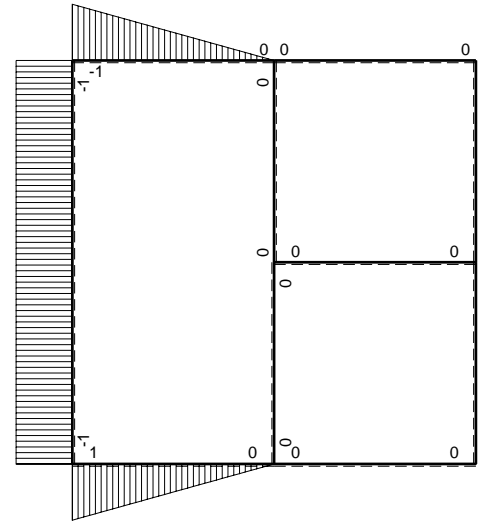

⊞ (+) ⊞ Mx flessione da iperstatica X=1

Quadro contributi PLV per iperstatica $X=W_{AD}$

→	$M_x(x)$	$M_0(x)$	θ	$M_x M_0$	$M_x \theta$	$M_x M_x$	$\int M_x(M_0/EJ+\theta)dx$	$\int X M_x M_x/EJdx$	
AB b	$1-x/b$	$-3/2Fx-1/2qx^2$	0	$-3/2Fx+Fx^2/b+1/2qx^3/b$	0	$1-2x/b+x^2/b^2$	$(-7/24+0)Fb^2/EJ$	$1/3Xb/EJ$	
BA b	$-x/b$	$2Fb-5/2Fx+1/2qx^2$	0	$-2Fx+5/2Fx^2/b-1/2qx^3/b$	0	x^2/b^2			
BC b	0	$-2Fb+2Fx$	0	0	0	0	0+0	0	
CB b	0	$2Fx$	0	0	0	0			
AD 2b	-1	$-5/4Fx+1/2qx^2$	0	$5/4Fx-1/2Fx^2/b$	0	1	$(7/6+0)Fb^2/EJ$	$2Xb/EJ$	
DA 2b	1	$1/2Fb+3/4Fx-1/2qx^2$	0	$1/2Fb+3/4Fx-1/2Fx^2/b$	0	1			
DE b	$-1+x/b$	$-1/2Fb+1/2Fx$	0	$1/2Fb-Fx+1/2Fx^2/b$	0	$1-2x/b+x^2/b^2$	$(1/6+0)Fb^2/EJ$	$1/3Xb/EJ$	
ED b	x/b	$1/2Fx$	0	$1/2Fx^2/b$	0	x^2/b^2			
EF b	0	0	0	0	0	0	0+0	0	
FE b	0	0	0	0	0	0			
FG b	0	$1/2Fx-1/2qx^2$	0	0	0	0	0+0	0	
GF b	0	$-1/2Fx+1/2qx^2$	0	0	0	0			
GC b	0	0	0	0	0	0	0+0	0	
CG b	0	0	0	0	0	0			
HG b	0	0	$-Fb/EJ$	0	0	0	0+0	0	
GH b	0	0	Fb/EJ	0	0	0			
HB b	0	$-5/4Fb+5/4Fx$	0	0	0	0	0+0	0	
BH b	0	$5/4Fx$	0	0	0	0			
HE b	0	$5/4Fb-5/4Fx$	0	0	0	0	0+0	0	
EH b	0	$-5/4Fx$	0	0	0	0			
AB	molla asta $-W_{1AB}(W_{0AB}+XW_{1AB})/k_{AB}$								$1/4Xb/EJ$
	totali							$25/24Fb^2/EJ$	$35/12Xb/EJ$
	iperstatica $X=W_{AD}$							$-5/14Fb$	

Sviluppi di calcolo iperstatica

$$L_{AB}^{xx} = \int_0^b (1 - 2x/b + x^2/b^2) \cdot 1/EJ \, dx - 1 \cdot (-1) \cdot 1/4 \cdot b/EJ = \left[x - x^2/b + 1/3 x^3/b^2 \right]_0^b \cdot 1/EJ - 1 \cdot (-1) \cdot 1/4 \cdot b/EJ$$

$$= (b - b + 1/3 b) \cdot 1/EJ - 1 \cdot (-1) \cdot 1/4 \cdot b/EJ = 7/12 \cdot b/EJ$$

$$L_{BA}^{xx} = \int_0^b (x^2/b^2) \cdot 1/EJ \, dx - 1 \cdot (-1) \cdot 1/4 \cdot b/EJ = \left[1/3 x^3/b^2 \right]_0^b \cdot 1/EJ - 1 \cdot (-1) \cdot 1/4 \cdot b/EJ$$

$$= (1/3 b) \cdot 1/EJ - 1 \cdot (-1) \cdot 1/4 \cdot b/EJ = 7/12 \cdot b/EJ$$

$$L_{AD}^{xx} = \int_0^{2b} (1) \cdot 1/EJ \, dx = \left[x \right]_0^{2b} \cdot 1/EJ$$

$$= (2b) \cdot 1/EJ = 2 \cdot b/EJ$$

$$L_{DA}^{xx} = \int_0^{2b} (1) \cdot 1/EJ \, dx = \left[x \right]_0^{2b} \cdot 1/EJ$$

$$= (2b) \cdot 1/EJ = 2 \cdot b/EJ$$

$$L_{DE}^{xx} = \int_0^b (1 - 2x/b + x^2/b^2) \cdot 1/EJ \, dx = \left[x - x^2/b + 1/3 x^3/b^2 \right]_0^b \cdot 1/EJ$$

$$= (b - b + 1/3 b) \cdot 1/EJ = 1/3 \cdot b/EJ$$

$$L_{ED}^{xx} = \int_0^b (x^2/b^2) \cdot 1/EJ \, dx = \left[1/3 x^3/b^2 \right]_0^b \cdot 1/EJ$$

$$= (1/3 b) \cdot 1/EJ = 1/3 \cdot b/EJ$$

$$L_{AB}^{xo} = \int_0^b (-3/2 x/b + x^2/b^2 + 1/2 x^3/b^3) \cdot Fb \cdot 1/EJ \, dx - 1 \cdot 0 \cdot 1/4 \cdot Fb^2/EJ$$

$$= \left[-3/4 x^2/b + 1/3 x^3/b^2 + 1/8 x^4/b^3 \right]_0^b \cdot Fb \cdot 1/EJ - 1 \cdot 0 \cdot 1/4 \cdot Fb^2/EJ$$

$$= (-3/4 b + 1/3 b + 1/8 b) \cdot Fb \cdot 1/EJ - 1 \cdot 0 \cdot 1/4 \cdot Fb^2/EJ = -7/24 \cdot Fb^2/EJ$$

$$L_{BA}^{xo} = \int_0^b (-2x/b + 5/2 x^2/b^2 - 1/2 x^3/b^3) \cdot Fb \cdot 1/EJ \, dx - 1 \cdot 0 \cdot 1/4 \cdot Fb^2/EJ$$

$$= \left[-x^2/b + 5/6 x^3/b^2 - 1/8 x^4/b^3 \right]_0^b \cdot Fb \cdot 1/EJ - 1 \cdot 0 \cdot 1/4 \cdot Fb^2/EJ$$

$$= (-b + 5/6 b - 1/8 b) \cdot Fb \cdot 1/EJ - 1 \cdot 0 \cdot 1/4 \cdot Fb^2/EJ = -7/24 \cdot Fb^2/EJ$$

$$L_{AD}^{xo} = \int_0^{2b} (5/4 x/b - 1/2 x^2/b^2) \cdot Fb \cdot 1/EJ \, dx = \left[5/8 x^2/b - 1/6 x^3/b^2 \right]_0^{2b} \cdot Fb \cdot 1/EJ$$

$$= (5/2 b - 4/3 b) \cdot Fb \cdot 1/EJ = 7/6 \cdot Fb^2/EJ$$

$$L_{DA}^{xo} = \int_0^{2b} (1/2 + 3/4 x/b - 1/2 x^2/b^2) \cdot Fb \cdot 1/EJ \, dx = \left[1/2 x + 3/8 x^2/b - 1/6 x^3/b^2 \right]_0^{2b} \cdot Fb \cdot 1/EJ$$

$$= (b + 3/2 b - 4/3 b) \cdot Fb \cdot 1/EJ = 7/6 \cdot Fb^2/EJ$$

$$L_{DE}^{xo} = \int_0^b (1/2 - x/b + 1/2 x^2/b^2) \cdot Fb \cdot 1/EJ \, dx = \left[1/2 x - 1/2 x^2/b + 1/6 x^3/b^2 \right]_0^b \cdot Fb \cdot 1/EJ$$

$$= (1/2 b - 1/2 b + 1/6 b) \cdot Fb \cdot 1/EJ = 1/6 \cdot Fb^2/EJ$$

$$L_{ED}^{xo} = \int_0^b (1/2 x^2/b^2) \cdot Fb \cdot 1/EJ \, dx = \left[1/6 x^3/b^2 \right]_0^b \cdot Fb \cdot 1/EJ$$

$$= (1/6 b) \cdot Fb \cdot 1/EJ = 1/6 \cdot Fb^2/EJ$$

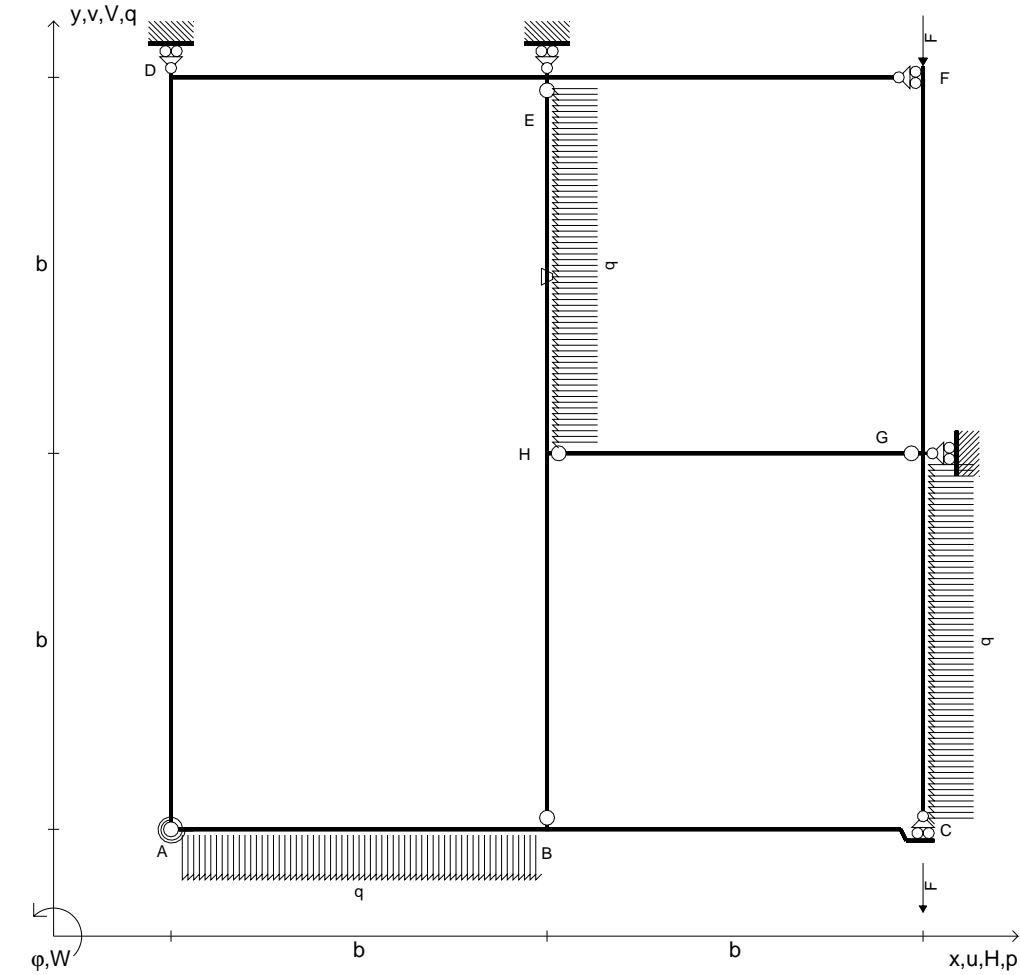

$V_{FG} = -F$	$k_{AB} = 4EJ/b$	$EJ_{FG} = EJ$
$V_{CB} = -F$	$EJ_{AB} = EJ$	$EJ_{GC} = EJ$
$q_{AB} = -q = -F/b$	$EJ_{BC} = EJ$	$EJ_{HG} = EJ$
$p_{HE} = -q = -F/b$	$EJ_{AD} = EJ$	$EJ_{HB} = EJ$
$p_{GC} = -q = -F/b$	$EJ_{DE} = EJ$	$EJ_{HE} = EJ$
$\theta_{HE} = -\theta = -\alpha T/b = -bF/EJ$	$EJ_{EF} = EJ$	

Reazioni iperstatiche in soluzione: $X=W_{AD}$
 Carichi e deformazioni date hanno verso efficace in disegno.
 Calcolare reazioni vincolari della struttura e delle aste.
 Tracciare i diagrammi quotati delle azioni interne nelle aste.
 $J_{YZ} - x_{YZ} - \theta_{YZ}$ riferimento locale asta YZ con origine in Y.
 Curvatura θ asta HE positiva se convessa a destra con inizio H.
 © Adolfo Zavelani Rossi, Politecnico di Milano, vers.27.03.13

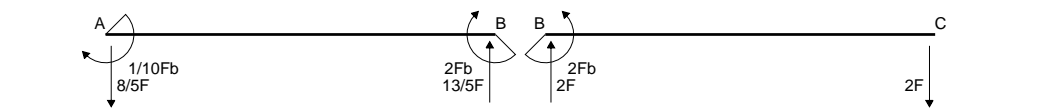
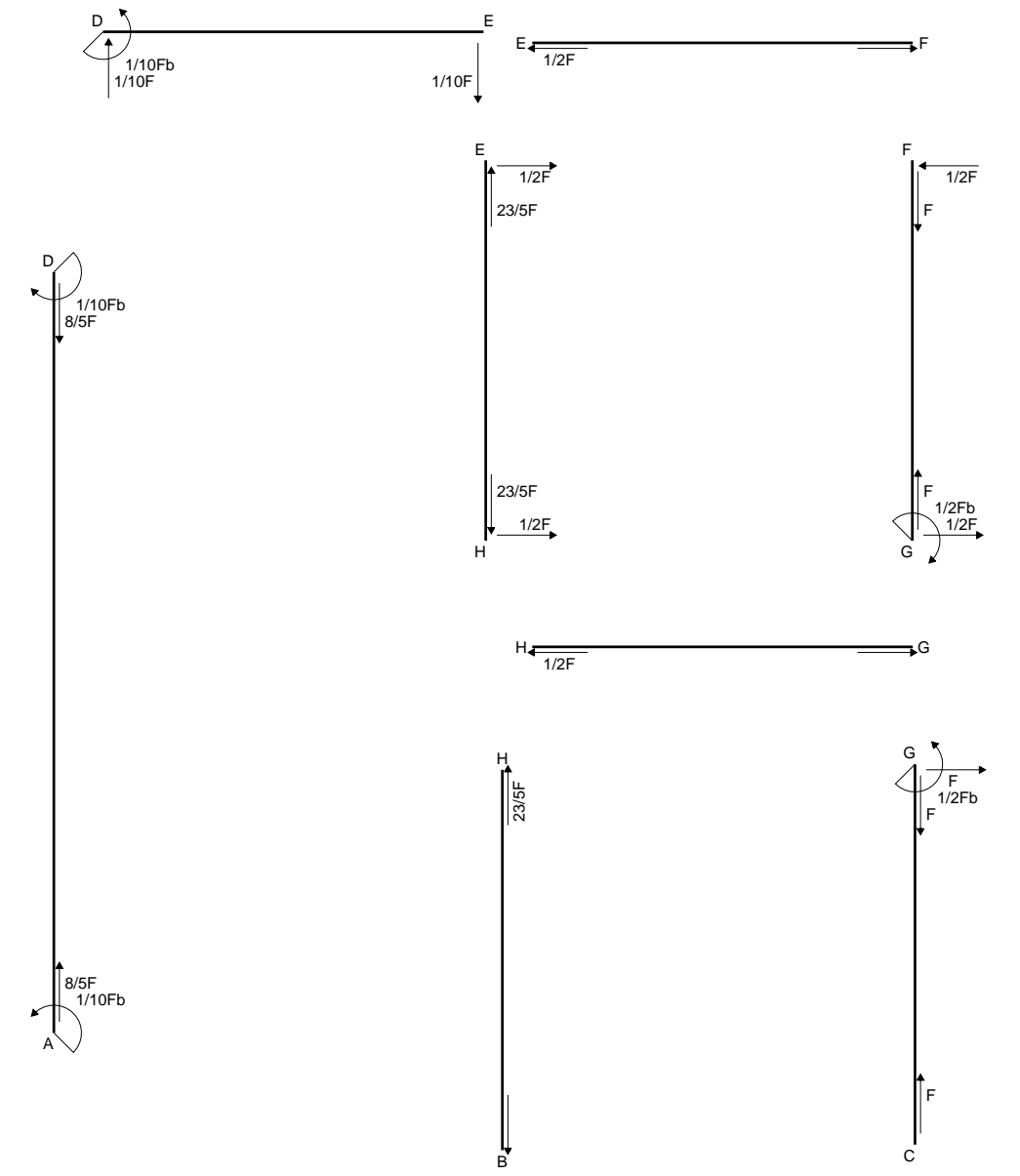

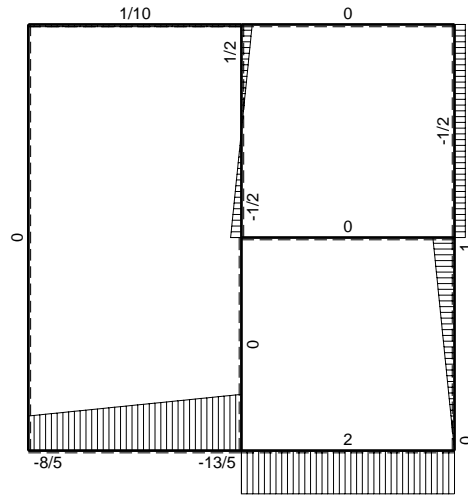
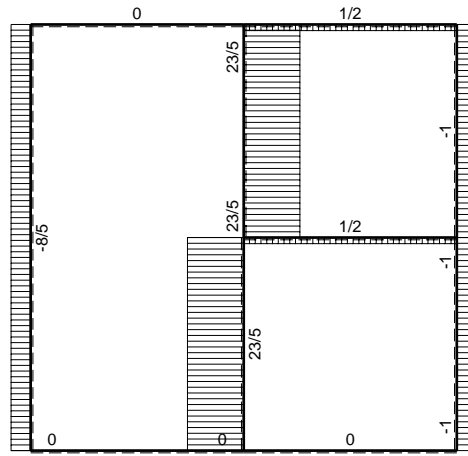

← ⊕ → F

↑ ⊕ ↓ F

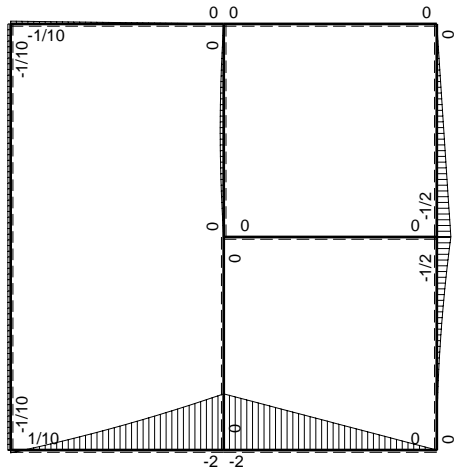

⊕ F_b

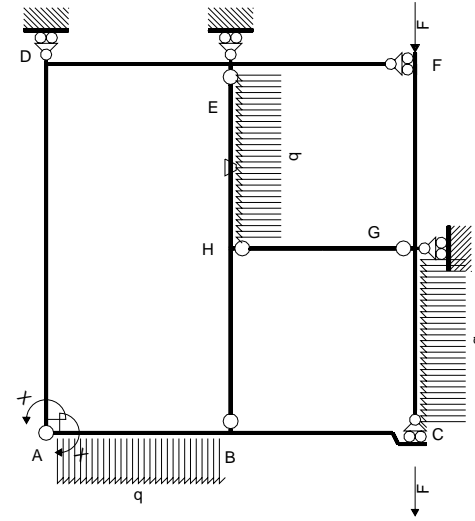

Schema di calcolo iperstatico

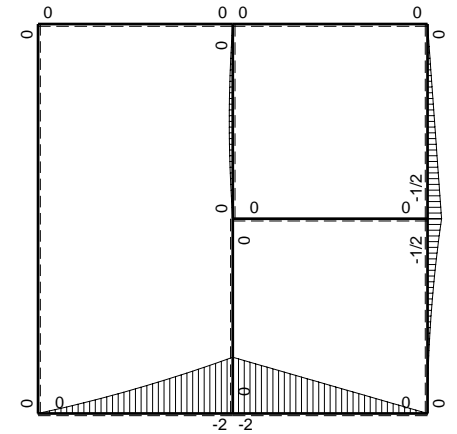

⊕ M_o flessione da carichi assegnati

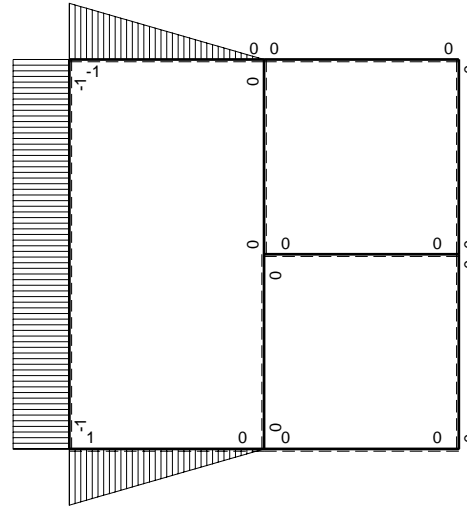

⊕ M_x flessione da iperstatica X=1

Quadro contributi PLV per iperstatica $X=W_{AD}$

→	$M_x(x)$	$M_o(x)$	θ	$M_x M_o$	$M_x \theta$	$M_x M_x$	$\int M_x(M_o/EJ+\theta)dx$	$\int X M_x M_x/EJ dx$	
AB b	$1-x/b$	$-3/2Fx-1/2qx^2$	0	$-3/2Fx+Fx^2/b+1/2qx^3/b$	0	$1-2x/b+x^2/b^2$	$(-7/24+0)Fb^2/EJ$	$1/3Xb/EJ$	
BA b	$-x/b$	$2Fb-5/2Fx+1/2qx^2$	0	$-2Fx+5/2Fx^2/b-1/2qx^3/b$	0	x^2/b^2			
BC b	0	$-2Fb+2Fx$	0	0	0	0	0+0	0	
CB b	0	$2Fx$	0	0	0	0			
AD 2b	-1	0	0	0	0	1	0+0	$2Xb/EJ$	
DA 2b	1	0	0	0	0	1			
DE b	$-1+x/b$	0	0	0	0	$1-2x/b+x^2/b^2$	0+0	$1/3Xb/EJ$	
ED b	x/b	0	0	0	0	x^2/b^2			
EF b	0	0	0	0	0	0	0+0	0	
FE b	0	0	0	0	0	0			
FG b	0	$-1/2Fx$	0	0	0	0	0+0	0	
GF b	0	$1/2Fb-1/2Fx$	0	0	0	0			
GC b	0	$-1/2Fb+Fx-1/2qx^2$	0	0	0	0	0+0	0	
CG b	0	$1/2qx^2$	0	0	0	0			
HG b	0	0	0	0	0	0	0+0	0	
GH b	0	0	0	0	0	0			
HB b	0	0	0	0	0	0	0+0	0	
BH b	0	0	0	0	0	0			
HE b	0	$-1/2Fx+1/2qx^2$	$-Fb/EJ$	0	0	0	0+0	0	
EH b	0	$1/2Fx-1/2qx^2$	Fb/EJ	0	0	0			
AB	molla asta $-W_{1AB}(W_{0AB}+XW_{1AB})/k_{AB}$								$1/4Xb/EJ$
	totali							$-7/24Fb^2/EJ$	$35/12Xb/EJ$
	iperstatica $X=W_{AD}$							$1/10Fb$	

Sviluppi di calcolo iperstatica

$$L_{AB}^{xx} = \int_0^b (1 - 2x/b + x^2/b^2) \cdot 1/EJ \, dx - 1 \cdot (-1) \cdot 1/4 \cdot b/EJ = \left[x - x^2/b + 1/3 x^3/b^2 \right]_0^b \cdot 1/EJ - 1 \cdot (-1) \cdot 1/4 \cdot b/EJ$$

$$= (b - b + 1/3 b) \cdot 1/EJ - 1 \cdot (-1) \cdot 1/4 \cdot b/EJ = 7/12 \cdot b/EJ$$

$$L_{BA}^{xx} = \int_0^b (x^2/b^2) \cdot 1/EJ \, dx - 1 \cdot (-1) \cdot 1/4 \cdot b/EJ = \left[1/3 x^3/b^2 \right]_0^b \cdot 1/EJ - 1 \cdot (-1) \cdot 1/4 \cdot b/EJ$$

$$= (1/3 b) \cdot 1/EJ - 1 \cdot (-1) \cdot 1/4 \cdot b/EJ = 7/12 \cdot b/EJ$$

$$L_{AD}^{xx} = \int_0^{2b} (1) \cdot 1/EJ \, dx = \left[x \right]_0^{2b} \cdot 1/EJ$$

$$= (2b) \cdot 1/EJ = 2 \cdot b/EJ$$

$$L_{DA}^{xx} = \int_0^{2b} (1) \cdot 1/EJ \, dx = \left[x \right]_0^{2b} \cdot 1/EJ$$

$$= (2b) \cdot 1/EJ = 2 \cdot b/EJ$$

$$L_{DE}^{xx} = \int_0^b (1 - 2x/b + x^2/b^2) \cdot 1/EJ \, dx = \left[x - x^2/b + 1/3 x^3/b^2 \right]_0^b \cdot 1/EJ$$

$$= (b - b + 1/3 b) \cdot 1/EJ = 1/3 \cdot b/EJ$$

$$L_{ED}^{xx} = \int_0^b (x^2/b^2) \cdot 1/EJ \, dx = \left[1/3 x^3/b^2 \right]_0^b \cdot 1/EJ$$

$$= (1/3 b) \cdot 1/EJ = 1/3 \cdot b/EJ$$

$$L_{AB}^{xo} = \int_0^b (-3/2 x/b + x^2/b^2 + 1/2 x^3/b^3) \cdot Fb \cdot 1/EJ \, dx - 1 \cdot 0 \cdot 1/4 \cdot Fb^2/EJ$$

$$= \left[-3/4 x^2/b + 1/3 x^3/b^2 + 1/8 x^4/b^3 \right]_0^b \cdot Fb \cdot 1/EJ - 1 \cdot 0 \cdot 1/4 \cdot Fb^2/EJ$$

$$= (-3/4 b + 1/3 b + 1/8 b) \cdot Fb \cdot 1/EJ - 1 \cdot 0 \cdot 1/4 \cdot Fb^2/EJ = -7/24 \cdot Fb^2/EJ$$

$$L_{BA}^{xo} = \int_0^b (-2x/b + 5/2 x^2/b^2 - 1/2 x^3/b^3) \cdot Fb \cdot 1/EJ \, dx - 1 \cdot 0 \cdot 1/4 \cdot Fb^2/EJ$$

$$= \left[-x^2/b + 5/6 x^3/b^2 - 1/8 x^4/b^3 \right]_0^b \cdot Fb \cdot 1/EJ - 1 \cdot 0 \cdot 1/4 \cdot Fb^2/EJ$$

$$= (-b + 5/6 b - 1/8 b) \cdot Fb \cdot 1/EJ - 1 \cdot 0 \cdot 1/4 \cdot Fb^2/EJ = -7/24 \cdot Fb^2/EJ$$

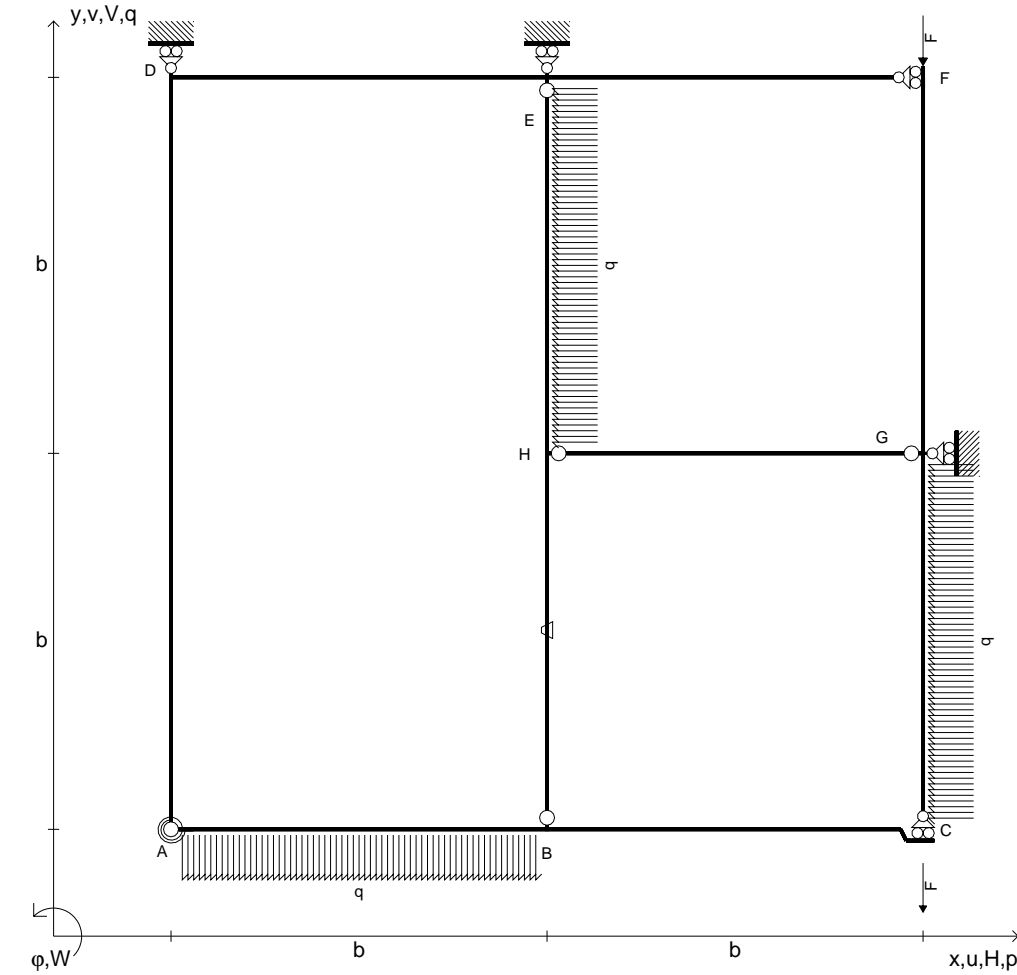

$V_{FG} = -F$	$k_{AB} = 4EJ/b$	$EJ_{FG} = EJ$
$V_{CB} = -F$	$EJ_{AB} = EJ$	$EJ_{GC} = EJ$
$q_{AB} = -q = -F/b$	$EJ_{BC} = EJ$	$EJ_{HG} = EJ$
$p_{HE} = -q = -F/b$	$EJ_{AD} = EJ$	$EJ_{HB} = EJ$
$p_{GC} = -q = -F/b$	$EJ_{DE} = EJ$	$EJ_{HE} = EJ$
$\theta_{HB} = -\theta = -\alpha T/b = -bF/EJ$	$EJ_{EF} = EJ$	

Reazioni iperstatiche in soluzione: $X=W_{DE}$

Carichi e deformazioni date hanno verso efficace in disegno.

Calcolare reazioni vincolari della struttura e delle aste.

Tracciare i diagrammi quotati delle azioni interne nelle aste.

$J_{YZ} - x_{YZ} - \theta_{YZ}$ riferimento locale asta YZ con origine in Y.

Curvatura θ asta HB positiva se convessa a destra con inizio H.

@ Adolfo Zavelani Rossi, Politecnico di Milano, vers.27.03.13

08.01.25

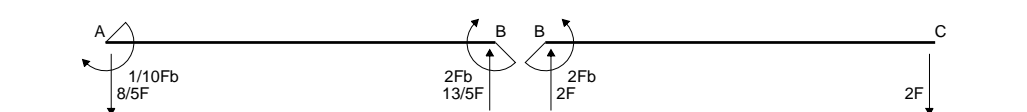
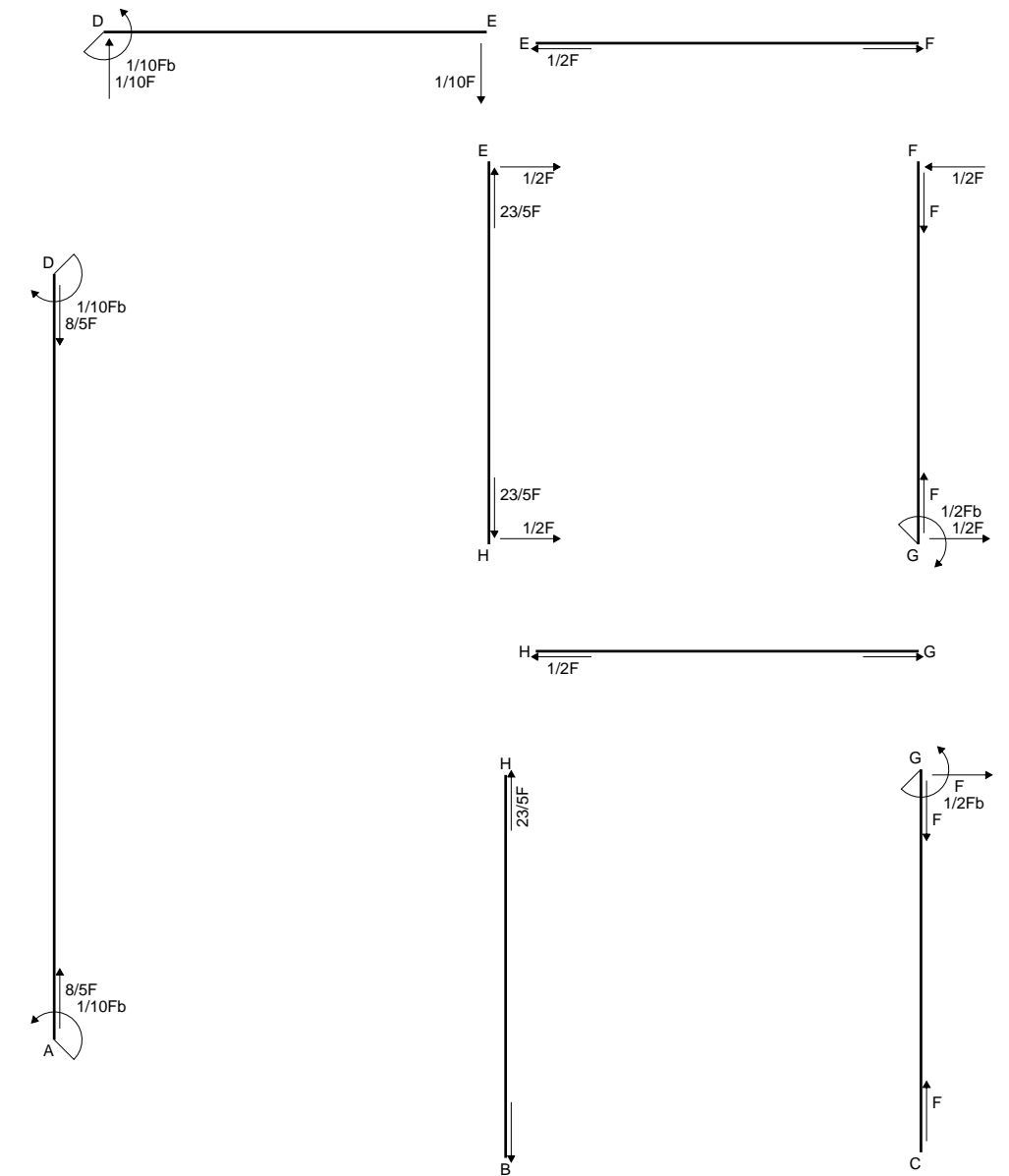

@ Adolfo Zavelani Rossi, Politecnico di Milano, vers.27.03.13

08.01.25

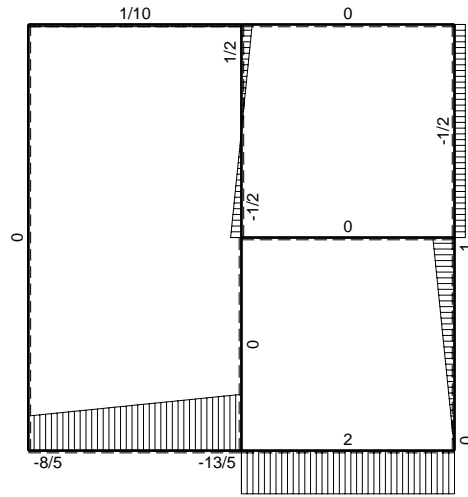
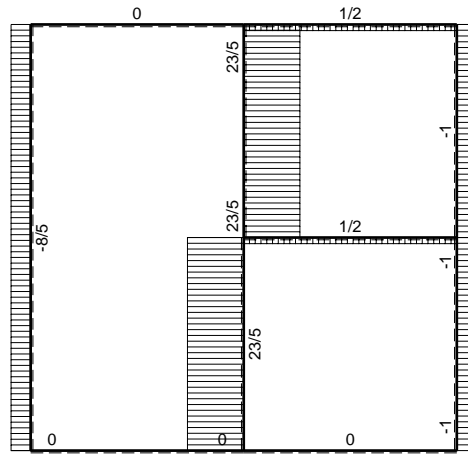

← (+) → F

↑ (+) ↓ F

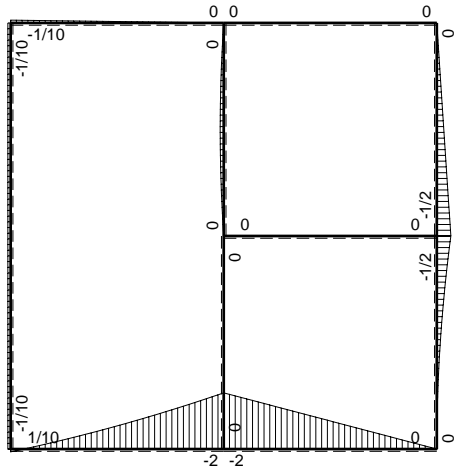

⌚ (+) ⌚ F_b

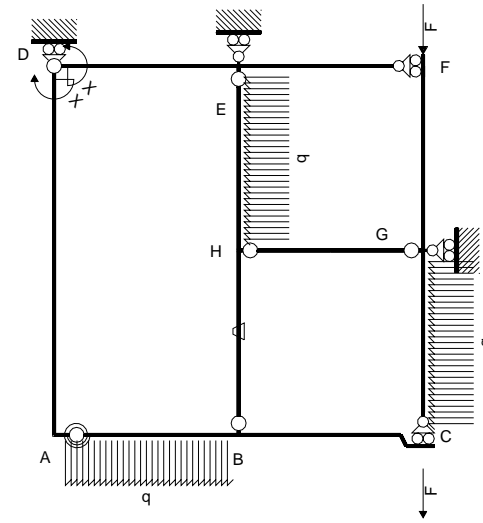

Schema di calcolo iperstatico

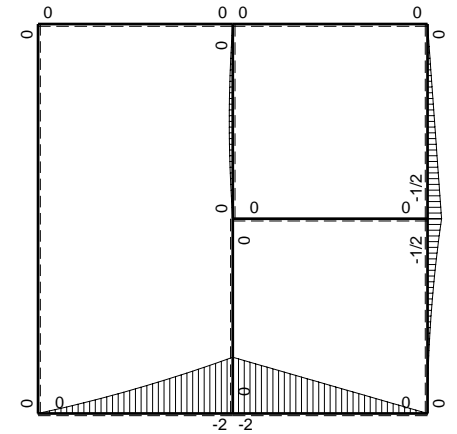

⌚ (+) ⌚ M₀ flessione da carichi assegnati

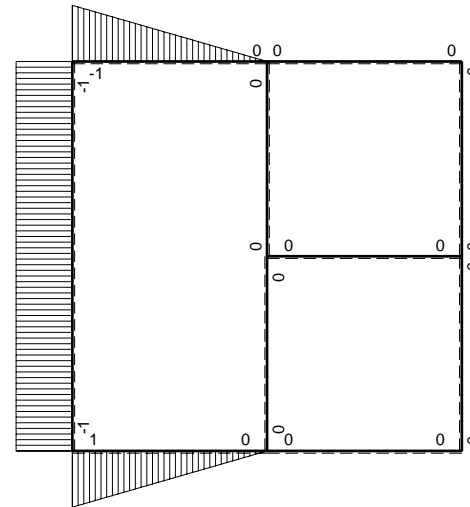

⌚ (+) ⌚ M_x flessione da iperstatica X=1

Quadro contributi PLV per iperstatica $X=W_{DE}$

→	$M_x(x)$	$M_o(x)$	θ	$M_x M_o$	$M_x \theta$	$M_x M_x$	$\int M_x(M_o/EJ+\theta)dx$	$\int X M_x M_x/EJ dx$	
AB b	$1-x/b$	$-3/2Fx-1/2qx^2$	0	$-3/2Fx+Fx^2/b+1/2qx^3/b$	0	$1-2x/b+x^2/b^2$	$(-7/24+0)Fb^2/EJ$	$1/3Xb/EJ$	
BA b	$-x/b$	$2Fb-5/2Fx+1/2qx^2$	0	$-2Fx+5/2Fx^2/b-1/2qx^3/b$	0	x^2/b^2			
BC b	0	$-2Fb+2Fx$	0	0	0	0	0+0	0	
CB b	0	$2Fx$	0	0	0	0			
AD 2b	-1	0	0	0	0	1	0+0	$2Xb/EJ$	
DA 2b	1	0	0	0	0	1			
DE b	$-1+x/b$	0	0	0	0	$1-2x/b+x^2/b^2$	0+0	$1/3Xb/EJ$	
ED b	x/b	0	0	0	0	x^2/b^2			
EF b	0	0	0	0	0	0	0+0	0	
FE b	0	0	0	0	0	0			
FG b	0	$-1/2Fx$	0	0	0	0	0+0	0	
GF b	0	$1/2Fb-1/2Fx$	0	0	0	0			
GC b	0	$-1/2Fb+Fx-1/2qx^2$	0	0	0	0	0+0	0	
CG b	0	$1/2qx^2$	0	0	0	0			
HG b	0	0	0	0	0	0	0+0	0	
GH b	0	0	0	0	0	0			
HB b	0	0	$-Fb/EJ$	0	0	0	0+0	0	
BH b	0	0	Fb/EJ	0	0	0			
HE b	0	$-1/2Fx+1/2qx^2$	0	0	0	0	0+0	0	
EH b	0	$1/2Fx-1/2qx^2$	0	0	0	0			
AB	molla asta $-W_{1AB}(W_{0AB}+XW_{1AB})/k_{AB}$								$1/4Xb/EJ$
	totali							$-7/24Fb^2/EJ$	$35/12Xb/EJ$
	iperstatica $X=W_{DE}$							$1/10Fb$	

Sviluppi di calcolo iperstatica

$$L_{AB}^{xx} = \int_0^b (1 - 2x/b + x^2/b^2) \cdot 1/EJ \, dx - 1 \cdot (-1) \cdot 1/4 \cdot b/EJ = \left[x - x^2/b + 1/3 x^3/b^2 \right]_0^b \cdot 1/EJ - 1 \cdot (-1) \cdot 1/4 \cdot b/EJ$$

$$= (b - b + 1/3 b) \cdot 1/EJ - 1 \cdot (-1) \cdot 1/4 \cdot b/EJ = 7/12 \cdot b/EJ$$

$$L_{BA}^{xx} = \int_0^b (x^2/b^2) \cdot 1/EJ \, dx - 1 \cdot (-1) \cdot 1/4 \cdot b/EJ = \left[1/3 x^3/b^2 \right]_0^b \cdot 1/EJ - 1 \cdot (-1) \cdot 1/4 \cdot b/EJ$$

$$= (1/3 b) \cdot 1/EJ - 1 \cdot (-1) \cdot 1/4 \cdot b/EJ = 7/12 \cdot b/EJ$$

$$L_{AD}^{xx} = \int_0^{2b} (1) \cdot 1/EJ \, dx = \left[x \right]_0^{2b} \cdot 1/EJ$$

$$= (2b) \cdot 1/EJ = 2 \cdot b/EJ$$

$$L_{DA}^{xx} = \int_0^{2b} (1) \cdot 1/EJ \, dx = \left[x \right]_0^{2b} \cdot 1/EJ$$

$$= (2b) \cdot 1/EJ = 2 \cdot b/EJ$$

$$L_{DE}^{xx} = \int_0^b (1 - 2x/b + x^2/b^2) \cdot 1/EJ \, dx = \left[x - x^2/b + 1/3 x^3/b^2 \right]_0^b \cdot 1/EJ$$

$$= (b - b + 1/3 b) \cdot 1/EJ = 1/3 \cdot b/EJ$$

$$L_{ED}^{xx} = \int_0^b (x^2/b^2) \cdot 1/EJ \, dx = \left[1/3 x^3/b^2 \right]_0^b \cdot 1/EJ$$

$$= (1/3 b) \cdot 1/EJ = 1/3 \cdot b/EJ$$

$$L_{AB}^{xo} = \int_0^b (-3/2 x/b + x^2/b^2 + 1/2 x^3/b^3) \cdot Fb \cdot 1/EJ \, dx - 1 \cdot 0 \cdot 1/4 \cdot Fb^2/EJ$$

$$= \left[-3/4 x^2/b + 1/3 x^3/b^2 + 1/8 x^4/b^3 \right]_0^b \cdot Fb \cdot 1/EJ - 1 \cdot 0 \cdot 1/4 \cdot Fb^2/EJ$$

$$= (-3/4 b + 1/3 b + 1/8 b) \cdot Fb \cdot 1/EJ - 1 \cdot 0 \cdot 1/4 \cdot Fb^2/EJ = -7/24 \cdot Fb^2/EJ$$

$$L_{BA}^{xo} = \int_0^b (-2x/b + 5/2 x^2/b^2 - 1/2 x^3/b^3) \cdot Fb \cdot 1/EJ \, dx - 1 \cdot 0 \cdot 1/4 \cdot Fb^2/EJ$$

$$= \left[-x^2/b + 5/6 x^3/b^2 - 1/8 x^4/b^3 \right]_0^b \cdot Fb \cdot 1/EJ - 1 \cdot 0 \cdot 1/4 \cdot Fb^2/EJ$$

$$= (-b + 5/6 b - 1/8 b) \cdot Fb \cdot 1/EJ - 1 \cdot 0 \cdot 1/4 \cdot Fb^2/EJ = -7/24 \cdot Fb^2/EJ$$

Quadro contributi PLV per iperstatica $X=W_{DA}$

→	$M_x(x)$	$M_0(x)$	θ	$M_x M_0$	$M_x \theta$	$M_x M_x$	$\int M_x(M_0/EJ+\theta)dx$	$\int X M_x M_x/EJ dx$	
AB b	$-1+x/b$	$-1/2Fb-3/2Fx-1/2qx^2$	0	$1/2Fb+Fx-Fx^2/b-1/2qx^3/b$	0	$1-2x/b+x^2/b^2$	$(13/24+0)Fb^2/EJ$	$1/3Xb/EJ$	
BA b	x/b	$5/2Fb-5/2Fx+1/2qx^2$	0	$5/2Fx-5/2Fx^2/b+1/2qx^3/b$	0	x^2/b^2			
BC b	0	$-5/2Fb+5/2Fx$	0	0	0	0	0+0	0	
CB b	0	$5/2Fx$	0	0	0	0			
AD 2b	1	$1/2Fb-1/4Fx$	0	$1/2Fb-1/4Fx$	0	1	$(1/2+0)Fb^2/EJ$	$2Xb/EJ$	
DA 2b	-1	$-1/4Fx$	0	$1/4Fx$	0	1			
DE b	$1-x/b$	0	0	0	0	$1-2x/b+x^2/b^2$	0+0	$1/3Xb/EJ$	
ED b	$-x/b$	0	0	0	0	x^2/b^2			
EF b	0	0	0	0	0	0	0+0	0	
FE b	0	0	0	0	0	0			
FG b	0	0	0	0	0	0	0+0	0	
GF b	0	0	0	0	0	0			
GC b	0	0	$-Fb/EJ$	0	0	0	0+0	0	
CG b	0	0	Fb/EJ	0	0	0			
HG b	0	$1/2Fx-1/2qx^2$	0	0	0	0	0+0	0	
GH b	0	$-1/2Fx+1/2qx^2$	0	0	0	0			
HB b	0	$-1/4Fb+1/4Fx$	0	0	0	0	0+0	0	
BH b	0	$1/4Fx$	0	0	0	0			
HE b	0	$1/4Fb-3/4Fx+1/2qx^2$	0	0	0	0	0+0	0	
EH b	0	$1/4Fx-1/2qx^2$	0	0	0	0			
AB	molla asta $-W_{1AB}(W_{0AB}+XW_{1AB})/k_{AB}$							$1/8Fb^2/EJ$	$1/4Xb/EJ$
	totali							$7/6Fb^2/EJ$	$35/12Xb/EJ$
	iperstatica $X=W_{DA}$							$-2/5Fb$	

Sviluppi di calcolo iperstatica

$$L_{AB}^{xx} = \int_0^b (1 - 2x/b + x^2/b^2) \cdot 1/EJ \, dx + 1 \cdot 1/4 \cdot b/EJ = \left[x - x^2/b + 1/3 x^3/b^2 \right]_0^b \cdot 1/EJ + 1 \cdot 1/4 \cdot b/EJ$$

$$= (b - b + 1/3 b) \cdot 1/EJ + 1 \cdot 1/4 \cdot b/EJ = 7/12 \cdot b/EJ$$

$$L_{BA}^{xx} = \int_0^b (x^2/b^2) \cdot 1/EJ \, dx + 1 \cdot 1/4 \cdot b/EJ = \left[1/3 x^3/b^2 \right]_0^b \cdot 1/EJ + 1 \cdot 1/4 \cdot b/EJ$$

$$= (1/3 b) \cdot 1/EJ + 1 \cdot 1/4 \cdot b/EJ = 7/12 \cdot b/EJ$$

$$L_{AD}^{xx} = \int_0^{2b} (1) \cdot 1/EJ \, dx = \left[x \right]_0^{2b} \cdot 1/EJ$$

$$= (2b) \cdot 1/EJ = 2 \cdot b/EJ$$

$$L_{DA}^{xx} = \int_0^{2b} (1) \cdot 1/EJ \, dx = \left[x \right]_0^{2b} \cdot 1/EJ$$

$$= (2b) \cdot 1/EJ = 2 \cdot b/EJ$$

$$L_{DE}^{xx} = \int_0^b (1 - 2x/b + x^2/b^2) \cdot 1/EJ \, dx = \left[x - x^2/b + 1/3 x^3/b^2 \right]_0^b \cdot 1/EJ$$

$$= (b - b + 1/3 b) \cdot 1/EJ = 1/3 \cdot b/EJ$$

$$L_{ED}^{xx} = \int_0^b (x^2/b^2) \cdot 1/EJ \, dx = \left[1/3 x^3/b^2 \right]_0^b \cdot 1/EJ$$

$$= (1/3 b) \cdot 1/EJ = 1/3 \cdot b/EJ$$

$$L_{AB}^{xo} = \int_0^b (1/2 + x/b - x^2/b^2 - 1/2 x^3/b^3) \cdot Fb \cdot 1/EJ \, dx + 1 \cdot 1/2 \cdot 1/4 \cdot Fb^2/EJ$$

$$= \left[1/2 x + 1/2 x^2/b - 1/3 x^3/b^2 - 1/8 x^4/b^3 \right]_0^b \cdot Fb \cdot 1/EJ + 1 \cdot 1/2 \cdot 1/4 \cdot Fb^2/EJ$$

$$= (1/2 b + 1/2 b - 1/3 b - 1/8 b) \cdot Fb \cdot 1/EJ + 1 \cdot 1/2 \cdot 1/4 \cdot Fb^2/EJ = 2/3 \cdot Fb^2/EJ$$

$$L_{BA}^{xo} = \int_0^b (5/2 x/b - 5/2 x^2/b^2 + 1/2 x^3/b^3) \cdot Fb \cdot 1/EJ \, dx + 1 \cdot 1/2 \cdot 1/4 \cdot Fb^2/EJ$$

$$= \left[5/4 x^2/b - 5/6 x^3/b^2 + 1/8 x^4/b^3 \right]_0^b \cdot Fb \cdot 1/EJ + 1 \cdot 1/2 \cdot 1/4 \cdot Fb^2/EJ$$

$$= (5/4 b - 5/6 b + 1/8 b) \cdot Fb \cdot 1/EJ + 1 \cdot 1/2 \cdot 1/4 \cdot Fb^2/EJ = 2/3 \cdot Fb^2/EJ$$

$$L_{AD}^{xo} = \int_0^{2b} (1/2 - 1/4 x/b) \cdot Fb \cdot 1/EJ \, dx = \left[1/2 x - 1/8 x^2/b \right]_0^{2b} \cdot Fb \cdot 1/EJ$$

$$= (b - 1/2 b) \cdot Fb \cdot 1/EJ = 1/2 \cdot Fb^2/EJ$$

$$L_{DA}^{xo} = \int_0^{2b} (1/4 x/b) \cdot Fb \cdot 1/EJ \, dx = \left[1/8 x^2/b \right]_0^{2b} \cdot Fb \cdot 1/EJ$$

$$= (1/2 b) \cdot Fb \cdot 1/EJ = 1/2 \cdot Fb^2/EJ$$

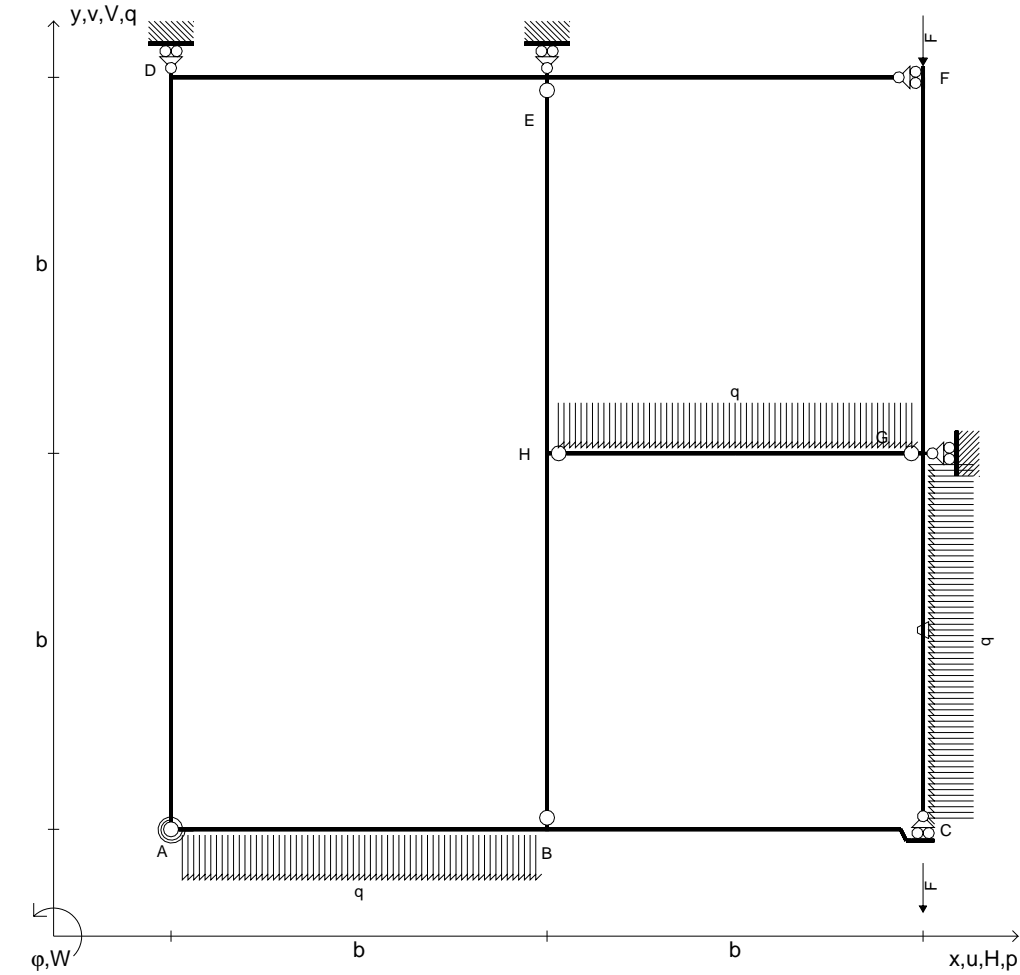

$V_{FG} = -F$	$k_{AB} = 4EJ/b$	$EJ_{FG} = EJ$
$V_{CB} = -F$	$EJ_{AB} = EJ$	$EJ_{GC} = EJ$
$q_{AB} = -q = -F/b$	$EJ_{BC} = EJ$	$EJ_{HG} = EJ$
$q_{HG} = -q = -F/b$	$EJ_{AD} = EJ$	$EJ_{HB} = EJ$
$p_{GC} = -q = -F/b$	$EJ_{DE} = EJ$	$EJ_{HE} = EJ$
$\theta_{GC} = -\theta = -\alpha T/b = -bF/EJ$	$EJ_{EF} = EJ$	

Reazioni iperstatiche in soluzione: $X=W_{DA}$
 Carichi e deformazioni date hanno verso efficace in disegno.
 Calcolare reazioni vincolari della struttura e delle aste.
 Tracciare i diagrammi quotati delle azioni interne nelle aste.
 $J_{YZ} - x_{YZ} - \theta_{YZ}$ riferimento locale asta YZ con origine in Y.
 Curvatura θ asta GC positiva se convessa a destra con inizio G.
 © Adolfo Zavelani Rossi, Politecnico di Milano, vers.27.03.13

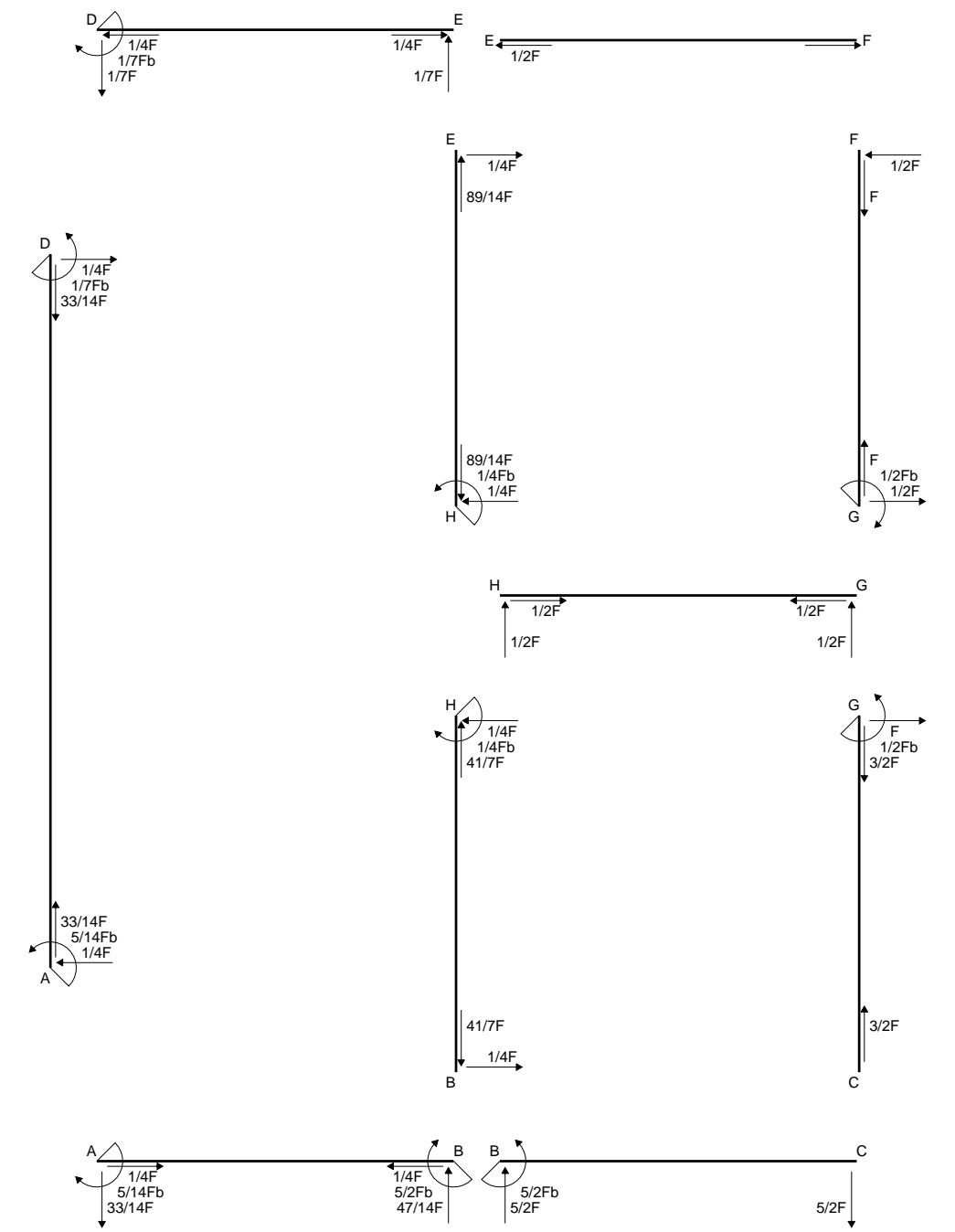

Quadro contributi PLV per iperstatica $X=W_{DA}$

→	$M_x(x)$	$M_o(x)$	θ	$M_x M_o$	$M_x \theta$	$M_x M_x$	$\int M_x(M_o/EJ+\theta)dx$	$\int X M_x M_x/EJ dx$	
AB b	$-1+x/b$	$1/2Fb-5/2Fx-1/2qx^2$	0	$-1/2Fb+3Fx-2Fx^2/b-1/2qx^3/b$	0	$1-2x/b+x^2/b^2$	$(5/24+0)Fb^2/EJ$	$1/3Xb/EJ$	
BA b	x/b	$5/2Fb-7/2Fx+1/2qx^2$	0	$5/2Fx-7/2Fx^2/b+1/2qx^3/b$	0	x^2/b^2			
BC b	0	$-5/2Fb+5/2Fx$	0	0	0	0	0+0	0	
CB b	0	$5/2Fx$	0	0	0	0			
AD 2b	1	$-1/2Fb+1/4Fx$	0	$-1/2Fb+1/4Fx$	0	1	$(-1/2+0)Fb^2/EJ$	$2Xb/EJ$	
DA 2b	-1	$1/4Fx$	0	$-1/4Fx$	0	1			
DE b	$1-x/b$	0	0	0	0	$1-2x/b+x^2/b^2$	0+0	$1/3Xb/EJ$	
ED b	$-x/b$	0	0	0	0	x^2/b^2			
EF b	0	0	0	0	0	0	0+0	0	
FE b	0	0	0	0	0	0			
FG b	0	$-1/2Fx$	0	0	0	0	0+0	0	
GF b	0	$1/2Fb-1/2Fx$	0	0	0	0			
GC b	0	$-1/2Fb+Fx-1/2qx^2$	$-Fb/EJ$	0	0	0	0+0	0	
CG b	0	$1/2qx^2$	Fb/EJ	0	0	0			
HG b	0	$1/2Fx-1/2qx^2$	0	0	0	0	0+0	0	
GH b	0	$-1/2Fx+1/2qx^2$	0	0	0	0			
HB b	0	$1/4Fb-1/4Fx$	0	0	0	0	0+0	0	
BH b	0	$-1/4Fx$	0	0	0	0			
HE b	0	$-1/4Fb+1/4Fx$	0	0	0	0	0+0	0	
EH b	0	$1/4Fx$	0	0	0	0			
AB	molla asta $-W_{1AB}(W_{0AB}+XW_{1AB})/k_{AB}$							$-1/8Fb^2/EJ$	$1/4Xb/EJ$
	totali							$-5/12Fb^2/EJ$	$35/12Xb/EJ$
	iperstatica $X=W_{DA}$							$1/7Fb$	

Sviluppi di calcolo iperstatica

$$L_{AB}^{xx} = \int_0^b (1 - 2x/b + x^2/b^2) \cdot 1/EJ \, dx + 1 \cdot 1/4 \cdot b/EJ = \left[x - x^2/b + 1/3 x^3/b^2 \right]_0^b \cdot 1/EJ + 1 \cdot 1/4 \cdot b/EJ$$

$$= (b - b + 1/3 b) \cdot 1/EJ + 1 \cdot 1/4 \cdot b/EJ = 7/12 \cdot b/EJ$$

$$L_{BA}^{xx} = \int_0^b (x^2/b^2) \cdot 1/EJ \, dx + 1 \cdot 1/4 \cdot b/EJ = \left[1/3 x^3/b^2 \right]_0^b \cdot 1/EJ + 1 \cdot 1/4 \cdot b/EJ$$

$$= (1/3 b) \cdot 1/EJ + 1 \cdot 1/4 \cdot b/EJ = 7/12 \cdot b/EJ$$

$$L_{AD}^{xx} = \int_0^{2b} (1) \cdot 1/EJ \, dx = \left[x \right]_0^{2b} \cdot 1/EJ$$

$$= (2b) \cdot 1/EJ = 2 \cdot b/EJ$$

$$L_{DA}^{xx} = \int_0^{2b} (1) \cdot 1/EJ \, dx = \left[x \right]_0^{2b} \cdot 1/EJ$$

$$= (2b) \cdot 1/EJ = 2 \cdot b/EJ$$

$$L_{DE}^{xx} = \int_0^b (1 - 2x/b + x^2/b^2) \cdot 1/EJ \, dx = \left[x - x^2/b + 1/3 x^3/b^2 \right]_0^b \cdot 1/EJ$$

$$= (b - b + 1/3 b) \cdot 1/EJ = 1/3 \cdot b/EJ$$

$$L_{ED}^{xx} = \int_0^b (x^2/b^2) \cdot 1/EJ \, dx = \left[1/3 x^3/b^2 \right]_0^b \cdot 1/EJ$$

$$= (1/3 b) \cdot 1/EJ = 1/3 \cdot b/EJ$$

$$L_{AB}^{xo} = \int_0^b (-1/2 + 3x/b - 2x^2/b^2 - 1/2 x^3/b^3) \cdot Fb \cdot 1/EJ \, dx + 1 \cdot (-1/2) \cdot 1/4 \cdot Fb^2/EJ$$

$$= \left[-1/2 x + 3/2 x^2/b - 2/3 x^3/b^2 - 1/8 x^4/b^3 \right]_0^b \cdot Fb \cdot 1/EJ + 1 \cdot (-1/2) \cdot 1/4 \cdot Fb^2/EJ$$

$$= (-1/2 b + 3/2 b - 2/3 b - 1/8 b) \cdot Fb \cdot 1/EJ + 1 \cdot (-1/2) \cdot 1/4 \cdot Fb^2/EJ = 1/12 \cdot Fb^2/EJ$$

$$L_{BA}^{xo} = \int_0^b (5/2 x/b - 7/2 x^2/b^2 + 1/2 x^3/b^3) \cdot Fb \cdot 1/EJ \, dx + 1 \cdot (-1/2) \cdot 1/4 \cdot Fb^2/EJ$$

$$= \left[5/4 x^2/b - 7/6 x^3/b^2 + 1/8 x^4/b^3 \right]_0^b \cdot Fb \cdot 1/EJ + 1 \cdot (-1/2) \cdot 1/4 \cdot Fb^2/EJ$$

$$= (5/4 b - 7/6 b + 1/8 b) \cdot Fb \cdot 1/EJ + 1 \cdot (-1/2) \cdot 1/4 \cdot Fb^2/EJ = 1/12 \cdot Fb^2/EJ$$

$$L_{AD}^{xo} = \int_0^{2b} (-1/2 + 1/4 x/b) \cdot Fb \cdot 1/EJ \, dx = \left[-1/2 x + 1/8 x^2/b \right]_0^{2b} \cdot Fb \cdot 1/EJ$$

$$= (-b + 1/2 b) \cdot Fb \cdot 1/EJ = -1/2 \cdot Fb^2/EJ$$

$$L_{DA}^{xo} = \int_0^{2b} (-1/4 x/b) \cdot Fb \cdot 1/EJ \, dx = \left[-1/8 x^2/b \right]_0^{2b} \cdot Fb \cdot 1/EJ$$

$$= (-1/2 b) \cdot Fb \cdot 1/EJ = -1/2 \cdot Fb^2/EJ$$

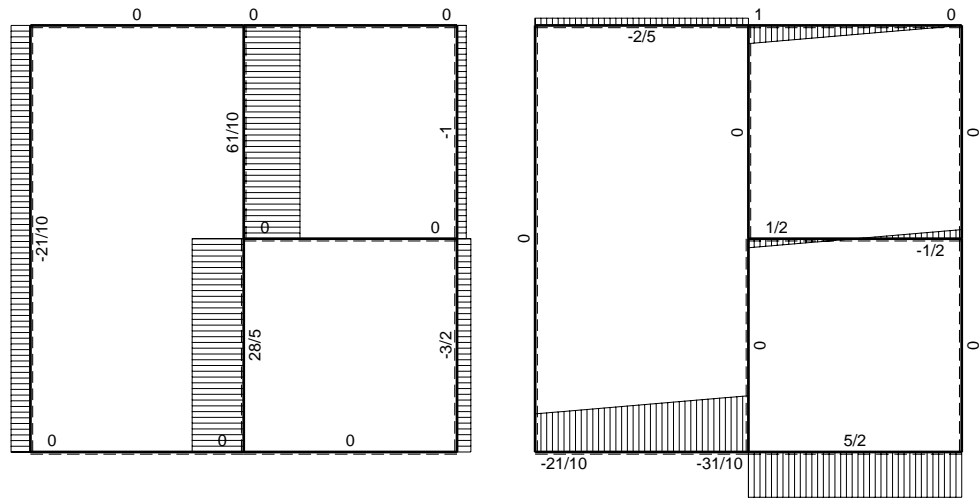

← (+) → F

↑ (+) ↓ F

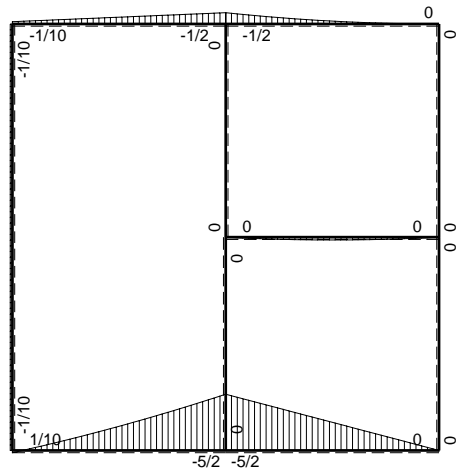

⌚ (+) ⌚ F_b

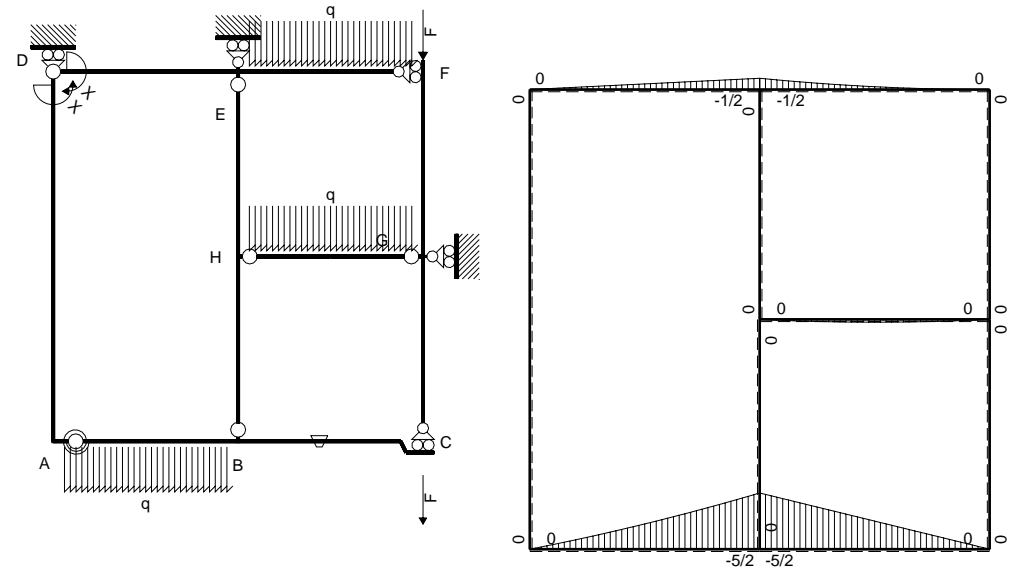

Schema di calcolo iperstatico

⌚ (+) ⌚ M_o flessione da carichi assegnati

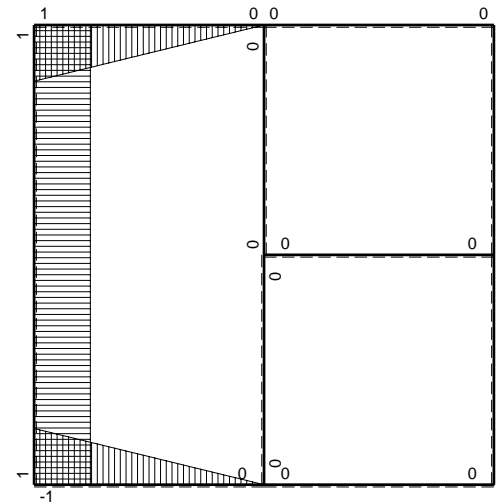

⌚ (+) ⌚ M_x flessione da iperstatica X=1

Quadro contributi PLV per iperstatica $X=W_{DA}$

→	$M_x(x)$	$M_o(x)$	θ	$M_x M_o$	$M_x \theta$	$M_x M_x$	$\int M_x(M_o/EJ+\theta)dx$	$\int X M_x M_x/EJ dx$	
AB b	$-1+x/b$	$-2Fx-1/2qx^2$	0	$2Fx-3/2Fx^2/b-1/2qx^3/b$	0	$1-2x/b+x^2/b^2$	$(3/8+0)Fb^2/EJ$	$1/3Xb/EJ$	
BA b	x/b	$5/2Fb-3Fx+1/2qx^2$	0	$5/2Fx-3Fx^2/b+1/2qx^3/b$	0	x^2/b^2			
BC b	0	$-5/2Fb+5/2Fx$	$-Fb/EJ$	0	0	0	0+0	0	
CB b	0	$5/2Fx$	Fb/EJ	0	0	0			
AD 2b	1	0	0	0	0	1	0+0	$2Xb/EJ$	
DA 2b	-1	0	0	0	0	1			
DE b	$1-x/b$	$-1/2Fx$	0	$-1/2Fx+1/2Fx^2/b$	0	$1-2x/b+x^2/b^2$	$(-1/12+0)Fb^2/EJ$	$1/3Xb/EJ$	
ED b	$-x/b$	$1/2Fb-1/2Fx$	0	$-1/2Fx+1/2Fx^2/b$	0	x^2/b^2			
EF b	0	$-1/2Fb+Fx-1/2qx^2$	0	0	0	0	0+0	0	
FE b	0	$1/2qx^2$	0	0	0	0			
FG b	0	0	0	0	0	0	0+0	0	
GF b	0	0	0	0	0	0			
GC b	0	0	0	0	0	0	0+0	0	
CG b	0	0	0	0	0	0			
HG b	0	$1/2Fx-1/2qx^2$	0	0	0	0	0+0	0	
GH b	0	$-1/2Fx+1/2qx^2$	0	0	0	0			
HB b	0	0	0	0	0	0	0+0	0	
BH b	0	0	0	0	0	0			
HE b	0	0	0	0	0	0	0+0	0	
EH b	0	0	0	0	0	0			
AB	molla asta $-W_{1AB}(W_{0AB}+XW_{1AB})/k_{AB}$								$1/4Xb/EJ$
	totali							$7/24Fb^2/EJ$	$35/12Xb/EJ$
	iperstatica $X=W_{DA}$							$-1/10Fb$	

Sviluppi di calcolo iperstatica

$$L_{AB}^{xx} = \int_0^b (1 - 2x/b + x^2/b^2) \cdot 1/EJ \, dx + 1 \cdot 1/4 \cdot b/EJ = \left[x - x^2/b + 1/3 x^3/b^2 \right]_0^b \cdot 1/EJ + 1 \cdot 1/4 \cdot b/EJ$$

$$= (b - b + 1/3 b) \cdot 1/EJ + 1 \cdot 1/4 \cdot b/EJ = 7/12 \cdot b/EJ$$

$$L_{BA}^{xx} = \int_0^b (x^2/b^2) \cdot 1/EJ \, dx + 1 \cdot 1/4 \cdot b/EJ = \left[1/3 x^3/b^2 \right]_0^b \cdot 1/EJ + 1 \cdot 1/4 \cdot b/EJ$$

$$= (1/3 b) \cdot 1/EJ + 1 \cdot 1/4 \cdot b/EJ = 7/12 \cdot b/EJ$$

$$L_{AD}^{xx} = \int_0^{2b} (1) \cdot 1/EJ \, dx = \left[x \right]_0^{2b} \cdot 1/EJ$$

$$= (2b) \cdot 1/EJ = 2 \cdot b/EJ$$

$$L_{DA}^{xx} = \int_0^{2b} (1) \cdot 1/EJ \, dx = \left[x \right]_0^{2b} \cdot 1/EJ$$

$$= (2b) \cdot 1/EJ = 2 \cdot b/EJ$$

$$L_{DE}^{xx} = \int_0^b (1 - 2x/b + x^2/b^2) \cdot 1/EJ \, dx = \left[x - x^2/b + 1/3 x^3/b^2 \right]_0^b \cdot 1/EJ$$

$$= (b - b + 1/3 b) \cdot 1/EJ = 1/3 \cdot b/EJ$$

$$L_{ED}^{xx} = \int_0^b (x^2/b^2) \cdot 1/EJ \, dx = \left[1/3 x^3/b^2 \right]_0^b \cdot 1/EJ$$

$$= (1/3 b) \cdot 1/EJ = 1/3 \cdot b/EJ$$

$$L_{AB}^{xo} = \int_0^b (2x/b - 3/2 x^2/b^2 - 1/2 x^3/b^3) \cdot Fb \cdot 1/EJ \, dx + 1 \cdot 0 \cdot 1/4 \cdot Fb^2/EJ$$

$$= \left[x^2/b - 1/2 x^3/b^2 - 1/8 x^4/b^3 \right]_0^b \cdot Fb \cdot 1/EJ + 1 \cdot 0 \cdot 1/4 \cdot Fb^2/EJ$$

$$= (b - 1/2 b - 1/8 b) \cdot Fb \cdot 1/EJ + 1 \cdot 0 \cdot 1/4 \cdot Fb^2/EJ = 3/8 \cdot Fb^2/EJ$$

$$L_{BA}^{xo} = \int_0^b (5/2 x/b - 3 x^2/b^2 + 1/2 x^3/b^3) \cdot Fb \cdot 1/EJ \, dx + 1 \cdot 0 \cdot 1/4 \cdot Fb^2/EJ$$

$$= \left[5/4 x^2/b - x^3/b^2 + 1/8 x^4/b^3 \right]_0^b \cdot Fb \cdot 1/EJ + 1 \cdot 0 \cdot 1/4 \cdot Fb^2/EJ$$

$$= (5/4 b - b + 1/8 b) \cdot Fb \cdot 1/EJ + 1 \cdot 0 \cdot 1/4 \cdot Fb^2/EJ = 3/8 \cdot Fb^2/EJ$$

$$L_{DE}^{xo} = \int_0^b (-1/2 x/b + 1/2 x^2/b^2) \cdot Fb \cdot 1/EJ \, dx = \left[-1/4 x^2/b + 1/6 x^3/b^2 \right]_0^b \cdot Fb \cdot 1/EJ$$

$$= (-1/4 b + 1/6 b) \cdot Fb \cdot 1/EJ = -1/12 \cdot Fb^2/EJ$$

$$L_{ED}^{xo} = \int_0^b (-1/2 x/b + 1/2 x^2/b^2) \cdot Fb \cdot 1/EJ \, dx = \left[-1/4 x^2/b + 1/6 x^3/b^2 \right]_0^b \cdot Fb \cdot 1/EJ$$

$$= (-1/4 b + 1/6 b) \cdot Fb \cdot 1/EJ = -1/12 \cdot Fb^2/EJ$$

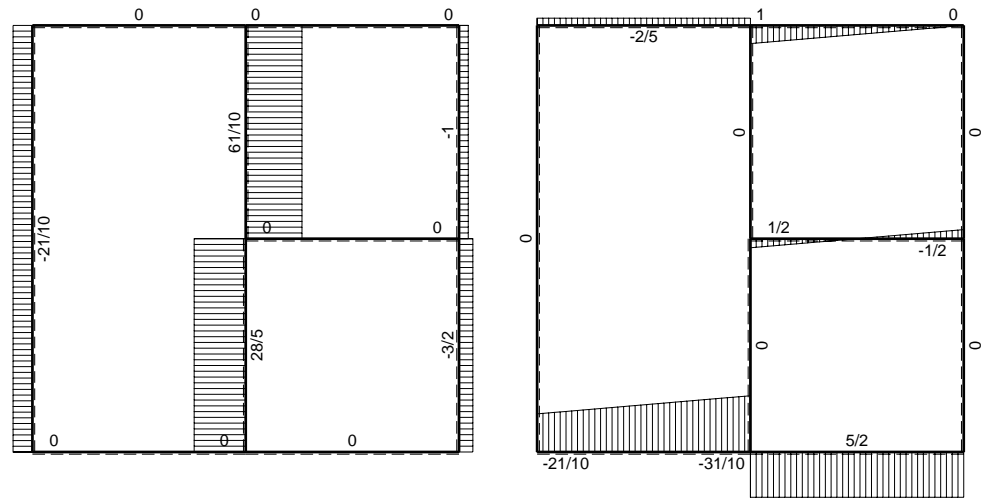

← (+) → F

↑ (+) ↓ F

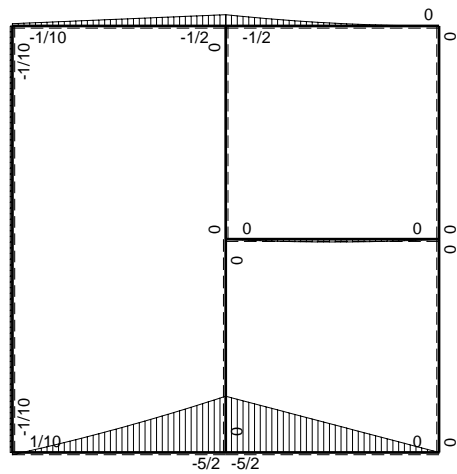

⤵ (+) ⤴ Mb

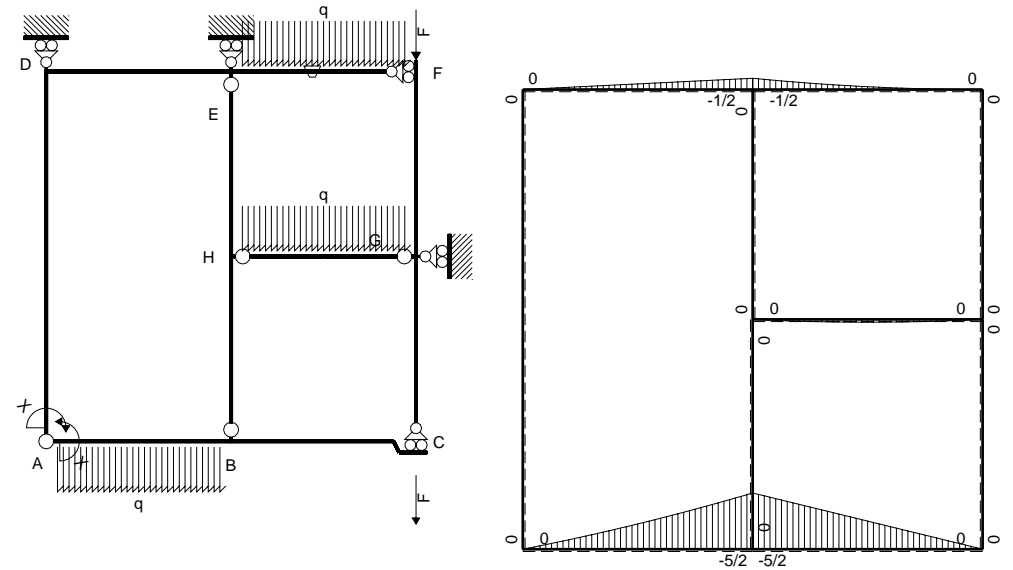

Schema di calcolo iperstatico

⤵ (+) ⤴ Mo flessione da carichi assegnati

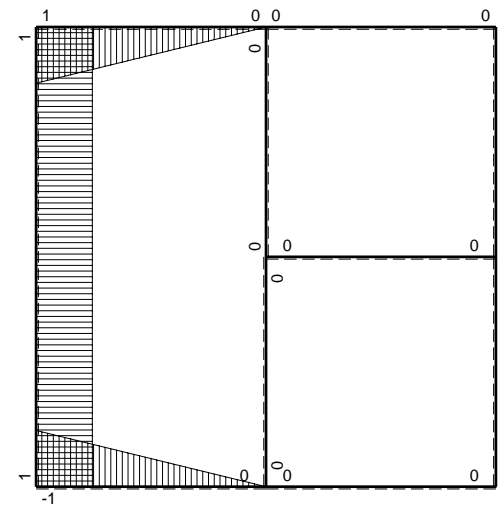

⤵ (+) ⤴ Mx flessione da iperstatica X=1

Quadro contributi PLV per iperstatica $X=W_{AB}$

→	$M_x(x)$	$M_o(x)$	θ	$M_x M_o$	$M_x \theta$	$M_x M_x$	$\int M_x(M_o/EJ+\theta)dx$	$\int X M_x M_x/EJ dx$	
AB b	$-1+x/b$	$-2Fx-1/2qx^2$	0	$2Fx-3/2Fx^2/b-1/2qx^3/b$	0	$1-2x/b+x^2/b^2$	$(3/8+0)Fb^2/EJ$	$1/3Xb/EJ$	
BA b	x/b	$5/2Fb-3Fx+1/2qx^2$	0	$5/2Fx-3Fx^2/b+1/2qx^3/b$	0	x^2/b^2			
BC b	0	$-5/2Fb+5/2Fx$	0	0	0	0	0+0	0	
CB b	0	$5/2Fx$	0	0	0	0			
AD 2b	1	0	0	0	0	1	0+0	$2Xb/EJ$	
DA 2b	-1	0	0	0	0	1			
DE b	$1-x/b$	$-1/2Fx$	0	$-1/2Fx+1/2Fx^2/b$	0	$1-2x/b+x^2/b^2$	$(-1/12+0)Fb^2/EJ$	$1/3Xb/EJ$	
ED b	$-x/b$	$1/2Fb-1/2Fx$	0	$-1/2Fx+1/2Fx^2/b$	0	x^2/b^2			
EF b	0	$-1/2Fb+Fx-1/2qx^2$	$-Fb/EJ$	0	0	0	0+0	0	
FE b	0	$1/2qx^2$	Fb/EJ	0	0	0			
FG b	0	0	0	0	0	0	0+0	0	
GF b	0	0	0	0	0	0			
GC b	0	0	0	0	0	0	0+0	0	
CG b	0	0	0	0	0	0			
HG b	0	$1/2Fx-1/2qx^2$	0	0	0	0	0+0	0	
GH b	0	$-1/2Fx+1/2qx^2$	0	0	0	0			
HB b	0	0	0	0	0	0	0+0	0	
BH b	0	0	0	0	0	0			
HE b	0	0	0	0	0	0	0+0	0	
EH b	0	0	0	0	0	0			
AB	molla asta $-W_{1AB}(W_{0AB}+XW_{1AB})/k_{AB}$								$1/4Xb/EJ$
	totali							$7/24Fb^2/EJ$	$35/12Xb/EJ$
	iperstatica $X=W_{AB}$							$-1/10Fb$	

Sviluppi di calcolo iperstatica

$$L_{AB}^{xx} = \int_0^b (1 - 2x/b + x^2/b^2) \cdot 1/EJ \, dx + 1 \cdot 1/4 \cdot b/EJ = \left[x - x^2/b + 1/3 x^3/b^2 \right]_0^b \cdot 1/EJ + 1 \cdot 1/4 \cdot b/EJ$$

$$= (b - b + 1/3 b) \cdot 1/EJ + 1 \cdot 1/4 \cdot b/EJ = 7/12 \cdot b/EJ$$

$$L_{BA}^{xx} = \int_0^b (x^2/b^2) \cdot 1/EJ \, dx + 1 \cdot 1/4 \cdot b/EJ = \left[1/3 x^3/b^2 \right]_0^b \cdot 1/EJ + 1 \cdot 1/4 \cdot b/EJ$$

$$= (1/3 b) \cdot 1/EJ + 1 \cdot 1/4 \cdot b/EJ = 7/12 \cdot b/EJ$$

$$L_{AD}^{xx} = \int_0^{2b} (1) \cdot 1/EJ \, dx = \left[x \right]_0^{2b} \cdot 1/EJ$$

$$= (2b) \cdot 1/EJ = 2 \cdot b/EJ$$

$$L_{DA}^{xx} = \int_0^{2b} (1) \cdot 1/EJ \, dx = \left[x \right]_0^{2b} \cdot 1/EJ$$

$$= (2b) \cdot 1/EJ = 2 \cdot b/EJ$$

$$L_{DE}^{xx} = \int_0^b (1 - 2x/b + x^2/b^2) \cdot 1/EJ \, dx = \left[x - x^2/b + 1/3 x^3/b^2 \right]_0^b \cdot 1/EJ$$

$$= (b - b + 1/3 b) \cdot 1/EJ = 1/3 \cdot b/EJ$$

$$L_{ED}^{xx} = \int_0^b (x^2/b^2) \cdot 1/EJ \, dx = \left[1/3 x^3/b^2 \right]_0^b \cdot 1/EJ$$

$$= (1/3 b) \cdot 1/EJ = 1/3 \cdot b/EJ$$

$$L_{AB}^{xo} = \int_0^b (2x/b - 3/2 x^2/b^2 - 1/2 x^3/b^3) \cdot Fb \cdot 1/EJ \, dx + 1 \cdot 0 \cdot 1/4 \cdot Fb^2/EJ$$

$$= \left[x^2/b - 1/2 x^3/b^2 - 1/8 x^4/b^3 \right]_0^b \cdot Fb \cdot 1/EJ + 1 \cdot 0 \cdot 1/4 \cdot Fb^2/EJ$$

$$= (b - 1/2 b - 1/8 b) \cdot Fb \cdot 1/EJ + 1 \cdot 0 \cdot 1/4 \cdot Fb^2/EJ = 3/8 \cdot Fb^2/EJ$$

$$L_{BA}^{xo} = \int_0^b (5/2 x/b - 3 x^2/b^2 + 1/2 x^3/b^3) \cdot Fb \cdot 1/EJ \, dx + 1 \cdot 0 \cdot 1/4 \cdot Fb^2/EJ$$

$$= \left[5/4 x^2/b - x^3/b^2 + 1/8 x^4/b^3 \right]_0^b \cdot Fb \cdot 1/EJ + 1 \cdot 0 \cdot 1/4 \cdot Fb^2/EJ$$

$$= (5/4 b - b + 1/8 b) \cdot Fb \cdot 1/EJ + 1 \cdot 0 \cdot 1/4 \cdot Fb^2/EJ = 3/8 \cdot Fb^2/EJ$$

$$L_{DE}^{xo} = \int_0^b (-1/2 x/b + 1/2 x^2/b^2) \cdot Fb \cdot 1/EJ \, dx = \left[-1/4 x^2/b + 1/6 x^3/b^2 \right]_0^b \cdot Fb \cdot 1/EJ$$

$$= (-1/4 b + 1/6 b) \cdot Fb \cdot 1/EJ = -1/12 \cdot Fb^2/EJ$$

$$L_{ED}^{xo} = \int_0^b (-1/2 x/b + 1/2 x^2/b^2) \cdot Fb \cdot 1/EJ \, dx = \left[-1/4 x^2/b + 1/6 x^3/b^2 \right]_0^b \cdot Fb \cdot 1/EJ$$

$$= (-1/4 b + 1/6 b) \cdot Fb \cdot 1/EJ = -1/12 \cdot Fb^2/EJ$$

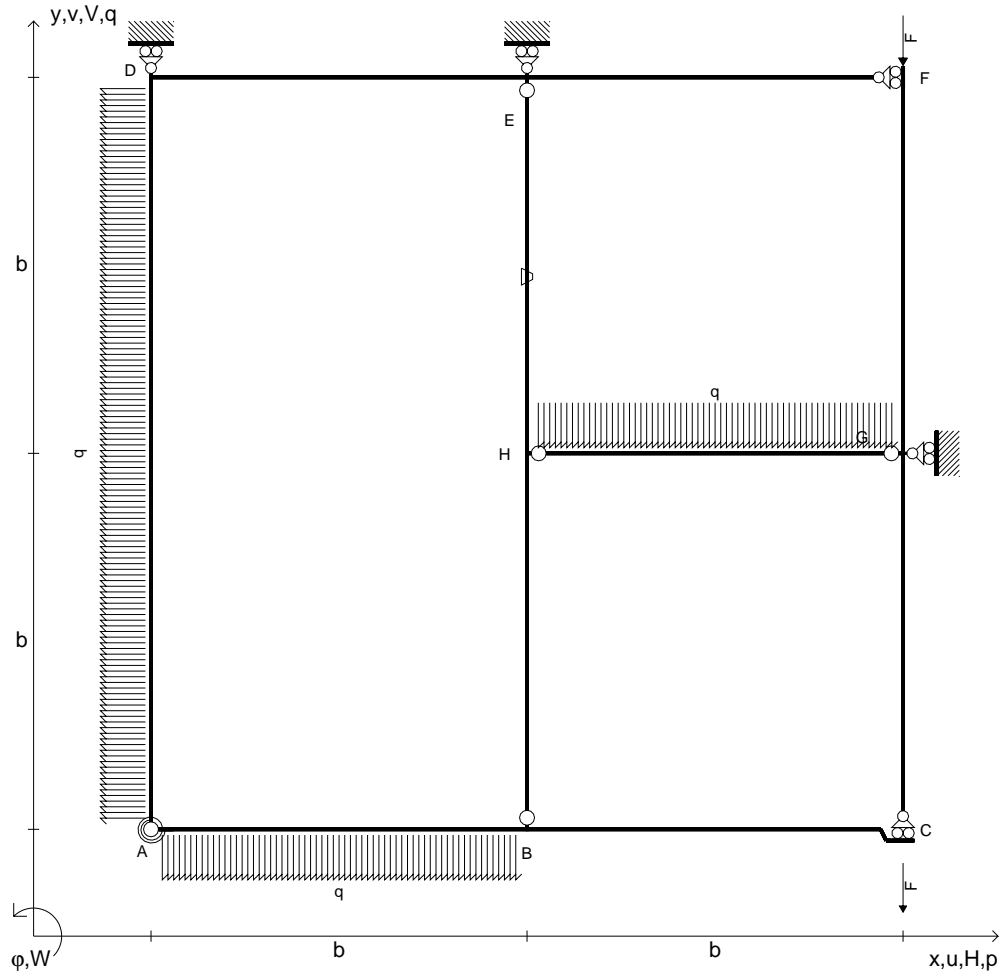

$V_{FG} = -F$	$k_{AB} = 4EJ/b$	$EJ_{FG} = EJ$
$V_{CB} = -F$	$EJ_{AB} = EJ$	$EJ_{GC} = EJ$
$q_{AB} = -q = -F/b$	$EJ_{BC} = EJ$	$EJ_{HG} = EJ$
$q_{HG} = -q = -F/b$	$EJ_{AD} = EJ$	$EJ_{HB} = EJ$
$p_{AD} = -q = -F/b$	$EJ_{DE} = EJ$	$EJ_{HE} = EJ$
$\theta_{HE} = -\theta = -\alpha T/b = -bF/EJ$	$EJ_{EF} = EJ$	

Reazioni iperstatiche in soluzione: $X=W_{AB}$
 Carichi e deformazioni date hanno verso efficace in disegno.
 Calcolare reazioni vincolari della struttura e delle aste.
 Tracciare i diagrammi quotati delle azioni interne nelle aste.
 $J_{YZ} - x_{YZ} - \theta_{YZ}$ riferimento locale asta YZ con origine in Y.
 Curvatura θ asta HE positiva se convessa a destra con inizio H.
 © Adolfo Zavelani Rossi, Politecnico di Milano, vers.27.03.13

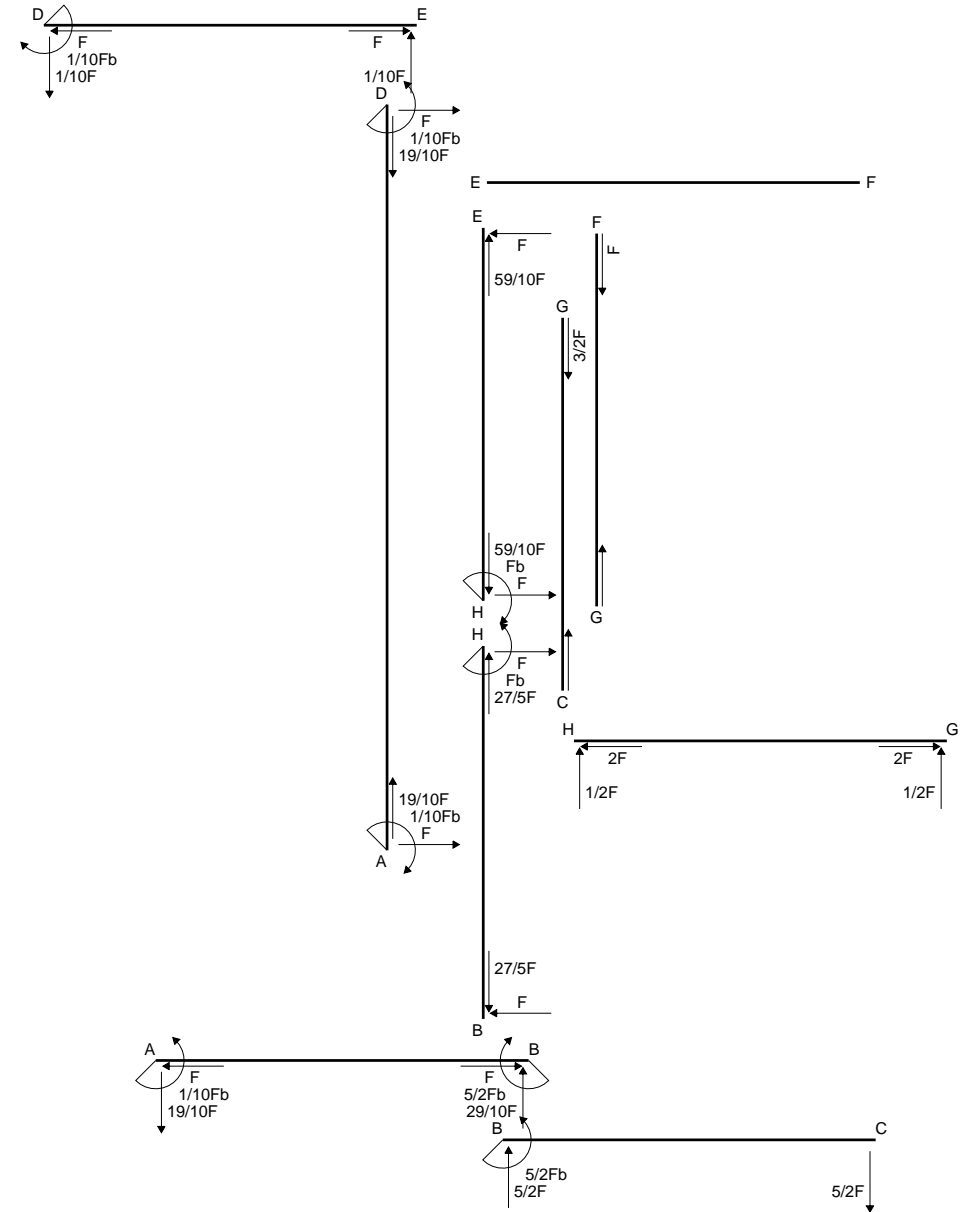

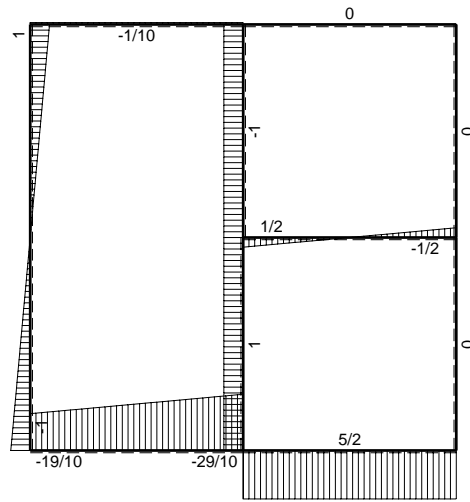
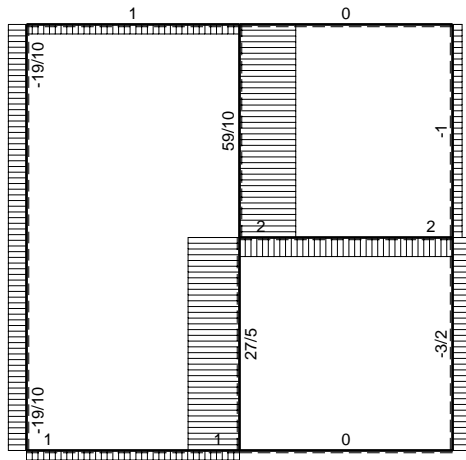

← ⊕ → F

↑ ⊕ ↓ F

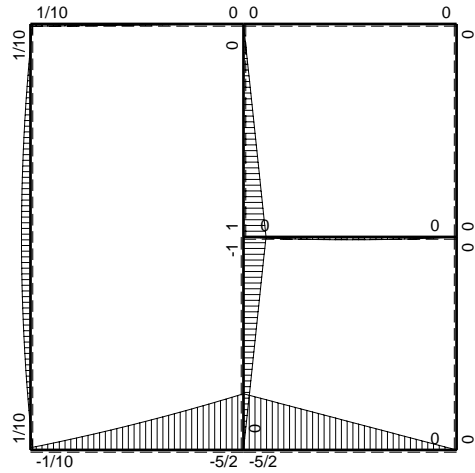

⊕ F_b

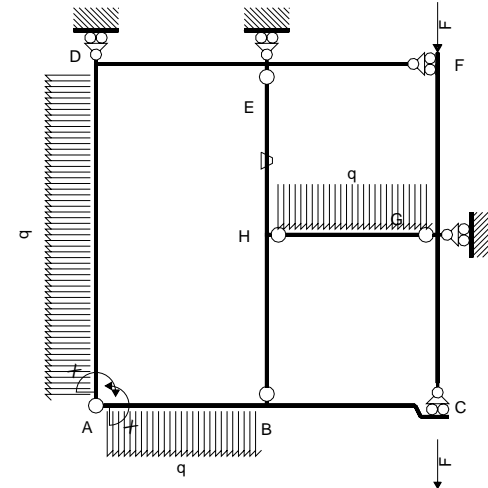

Schema di calcolo iperstatico

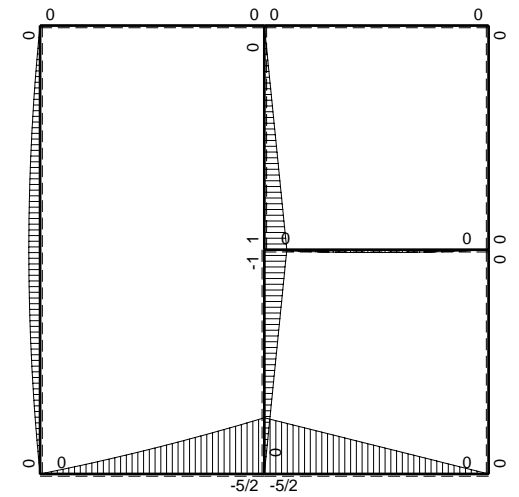

⊕ M₀ flessione da carichi assegnati

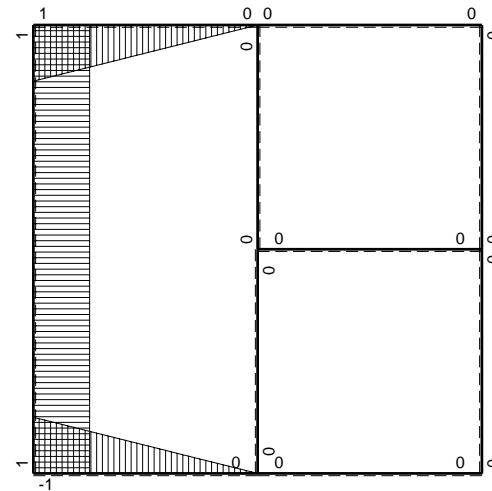

⊕ M_x flessione da iperstatica X=1

Quadro contributi PLV per iperstatica $X=W_{AB}$

→	$M_x(x)$	$M_o(x)$	θ	$M_x M_o$	$M_x \theta$	$M_x M_x$	$\int M_x(M_o/EJ+\theta)dx$	$\int X M_x M_x/EJ dx$	
AB b	$-1+x/b$	$-2Fx-1/2qx^2$	0	$2Fx-3/2Fx^2/b-1/2qx^3/b$	0	$1-2x/b+x^2/b^2$	$(3/8+0)Fb^2/EJ$	$1/3Xb/EJ$	
BA b	x/b	$5/2Fb-3Fx+1/2qx^2$	0	$5/2Fx-3Fx^2/b+1/2qx^3/b$	0	x^2/b^2			
BC b	0	$-5/2Fb+5/2Fx$	0	0	0	0	0+0	0	
CB b	0	$5/2Fx$	0	0	0	0			
AD 2b	1	$-Fx+1/2qx^2$	0	$-Fx+1/2Fx^2/b$	0	1	$(-2/3+0)Fb^2/EJ$	$2Xb/EJ$	
DA 2b	-1	$Fx-1/2qx^2$	0	$-Fx+1/2Fx^2/b$	0	1			
DE b	$1-x/b$	0	0	0	0	$1-2x/b+x^2/b^2$	0+0	$1/3Xb/EJ$	
ED b	$-x/b$	0	0	0	0	x^2/b^2			
EF b	0	0	0	0	0	0	0+0	0	
FE b	0	0	0	0	0	0			
FG b	0	0	0	0	0	0	0+0	0	
GF b	0	0	0	0	0	0			
GC b	0	0	0	0	0	0	0+0	0	
CG b	0	0	0	0	0	0			
HG b	0	$1/2Fx-1/2qx^2$	0	0	0	0	0+0	0	
GH b	0	$-1/2Fx+1/2qx^2$	0	0	0	0			
HB b	0	$-Fb+Fx$	0	0	0	0	0+0	0	
BH b	0	Fx	0	0	0	0			
HE b	0	$Fb-Fx$	$-Fb/EJ$	0	0	0	0+0	0	
EH b	0	$-Fx$	Fb/EJ	0	0	0			
AB	molla asta $-W_{1AB}(W_{0AB}+XW_{1AB})/k_{AB}$								$1/4Xb/EJ$
	totali							$-7/24Fb^2/EJ$	$35/12Xb/EJ$
	iperstatica $X=W_{AB}$							$1/10Fb$	

Sviluppi di calcolo iperstatica

$$L_{AB}^{xx} = \int_0^b (1 - 2x/b + x^2/b^2) \cdot 1/EJ \, dx + 1 \cdot 1/4 \cdot b/EJ = \left[x - x^2/b + 1/3 x^3/b^2 \right]_0^b \cdot 1/EJ + 1 \cdot 1/4 \cdot b/EJ$$

$$= (b - b + 1/3 b) \cdot 1/EJ + 1 \cdot 1/4 \cdot b/EJ = 7/12 \cdot b/EJ$$

$$L_{BA}^{xx} = \int_0^b (x^2/b^2) \cdot 1/EJ \, dx + 1 \cdot 1/4 \cdot b/EJ = \left[1/3 x^3/b^2 \right]_0^b \cdot 1/EJ + 1 \cdot 1/4 \cdot b/EJ$$

$$= (1/3 b) \cdot 1/EJ + 1 \cdot 1/4 \cdot b/EJ = 7/12 \cdot b/EJ$$

$$L_{AD}^{xx} = \int_0^{2b} (1) \cdot 1/EJ \, dx = \left[x \right]_0^{2b} \cdot 1/EJ$$

$$= (2b) \cdot 1/EJ = 2 \cdot b/EJ$$

$$L_{DA}^{xx} = \int_0^{2b} (1) \cdot 1/EJ \, dx = \left[x \right]_0^{2b} \cdot 1/EJ$$

$$= (2b) \cdot 1/EJ = 2 \cdot b/EJ$$

$$L_{DE}^{xx} = \int_0^b (1 - 2x/b + x^2/b^2) \cdot 1/EJ \, dx = \left[x - x^2/b + 1/3 x^3/b^2 \right]_0^b \cdot 1/EJ$$

$$= (b - b + 1/3 b) \cdot 1/EJ = 1/3 \cdot b/EJ$$

$$L_{ED}^{xx} = \int_0^b (x^2/b^2) \cdot 1/EJ \, dx = \left[1/3 x^3/b^2 \right]_0^b \cdot 1/EJ$$

$$= (1/3 b) \cdot 1/EJ = 1/3 \cdot b/EJ$$

$$L_{AB}^{xo} = \int_0^b (2x/b - 3/2 x^2/b^2 - 1/2 x^3/b^3) \cdot Fb \cdot 1/EJ \, dx + 1 \cdot 0 \cdot 1/4 \cdot Fb^2/EJ$$

$$= \left[x^2/b - 1/2 x^3/b^2 - 1/8 x^4/b^3 \right]_0^b \cdot Fb \cdot 1/EJ + 1 \cdot 0 \cdot 1/4 \cdot Fb^2/EJ$$

$$= (b - 1/2 b - 1/8 b) \cdot Fb \cdot 1/EJ + 1 \cdot 0 \cdot 1/4 \cdot Fb^2/EJ = 3/8 \cdot Fb^2/EJ$$

$$L_{BA}^{xo} = \int_0^b (5/2 x/b - 3 x^2/b^2 + 1/2 x^3/b^3) \cdot Fb \cdot 1/EJ \, dx + 1 \cdot 0 \cdot 1/4 \cdot Fb^2/EJ$$

$$= \left[5/4 x^2/b - x^3/b^2 + 1/8 x^4/b^3 \right]_0^b \cdot Fb \cdot 1/EJ + 1 \cdot 0 \cdot 1/4 \cdot Fb^2/EJ$$

$$= (5/4 b - b + 1/8 b) \cdot Fb \cdot 1/EJ + 1 \cdot 0 \cdot 1/4 \cdot Fb^2/EJ = 3/8 \cdot Fb^2/EJ$$

$$L_{AD}^{xo} = \int_0^{2b} (-x/b + 1/2 x^2/b^2) \cdot Fb \cdot 1/EJ \, dx = \left[-1/2 x^2/b + 1/6 x^3/b^2 \right]_0^{2b} \cdot Fb \cdot 1/EJ$$

$$= (-2b + 4/3 b) \cdot Fb \cdot 1/EJ = -2/3 \cdot Fb^2/EJ$$

$$L_{DA}^{xo} = \int_0^{2b} (-x/b + 1/2 x^2/b^2) \cdot Fb \cdot 1/EJ \, dx = \left[-1/2 x^2/b + 1/6 x^3/b^2 \right]_0^{2b} \cdot Fb \cdot 1/EJ$$

$$= (-2b + 4/3 b) \cdot Fb \cdot 1/EJ = -2/3 \cdot Fb^2/EJ$$

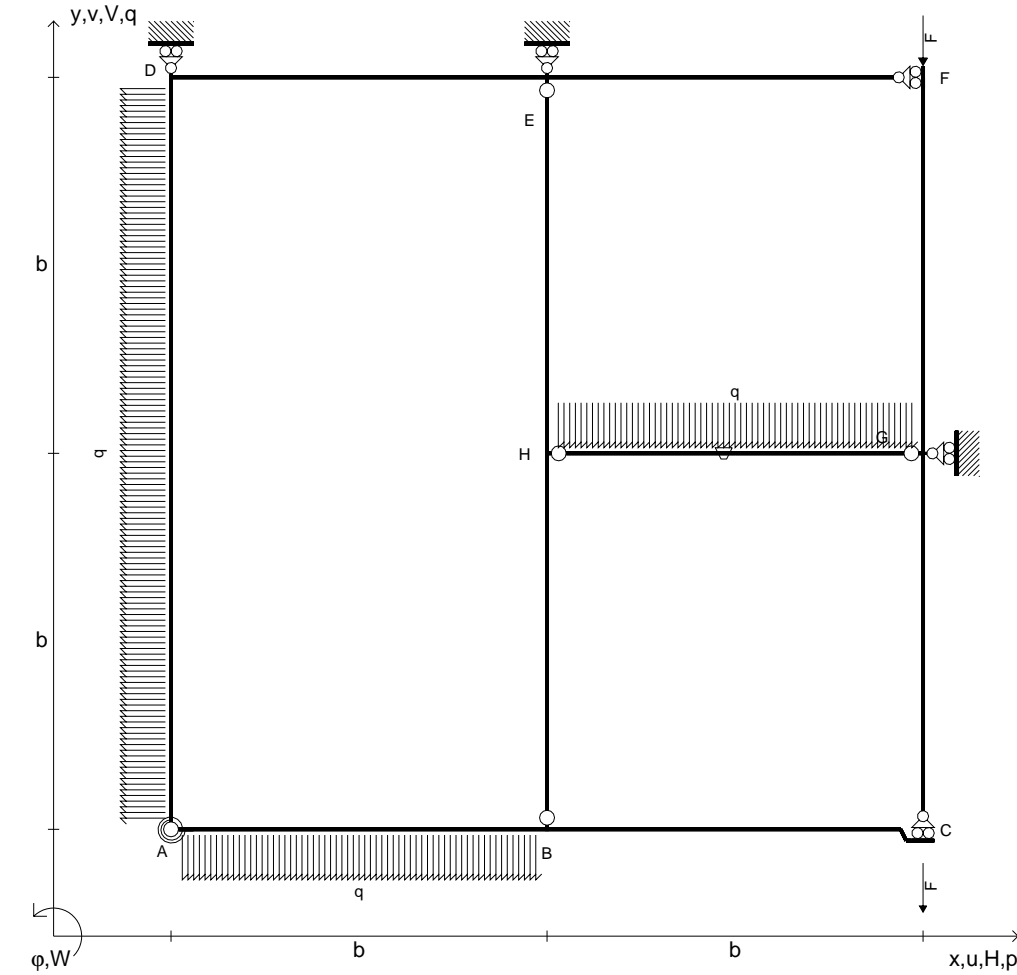

$V_{FG} = -F$	$k_{AB} = 4EJ/b$	$EJ_{FG} = EJ$
$V_{CB} = -F$	$EJ_{AB} = EJ$	$EJ_{GC} = EJ$
$q_{AB} = -q = -F/b$	$EJ_{BC} = EJ$	$EJ_{HG} = EJ$
$q_{HG} = -q = -F/b$	$EJ_{AD} = EJ$	$EJ_{HB} = EJ$
$p_{AD} = -q = -F/b$	$EJ_{DE} = EJ$	$EJ_{HE} = EJ$
$\theta_{HG} = -\theta = -\alpha T/b = -bF/EJ$	$EJ_{EF} = EJ$	

Reazioni iperstatiche in soluzione: $X=W_{AB}$
 Carichi e deformazioni date hanno verso efficace in disegno.
 Calcolare reazioni vincolari della struttura e delle aste.
 Tracciare i diagrammi quotati delle azioni interne nelle aste.
 $J_{YZ} - x_{YZ} - \theta_{YZ}$ riferimento locale asta YZ con origine in Y.
 Curvatura θ asta HG positiva se convessa a destra con inizio H.
 © Adolfo Zavelani Rossi, Politecnico di Milano, vers.27.03.13

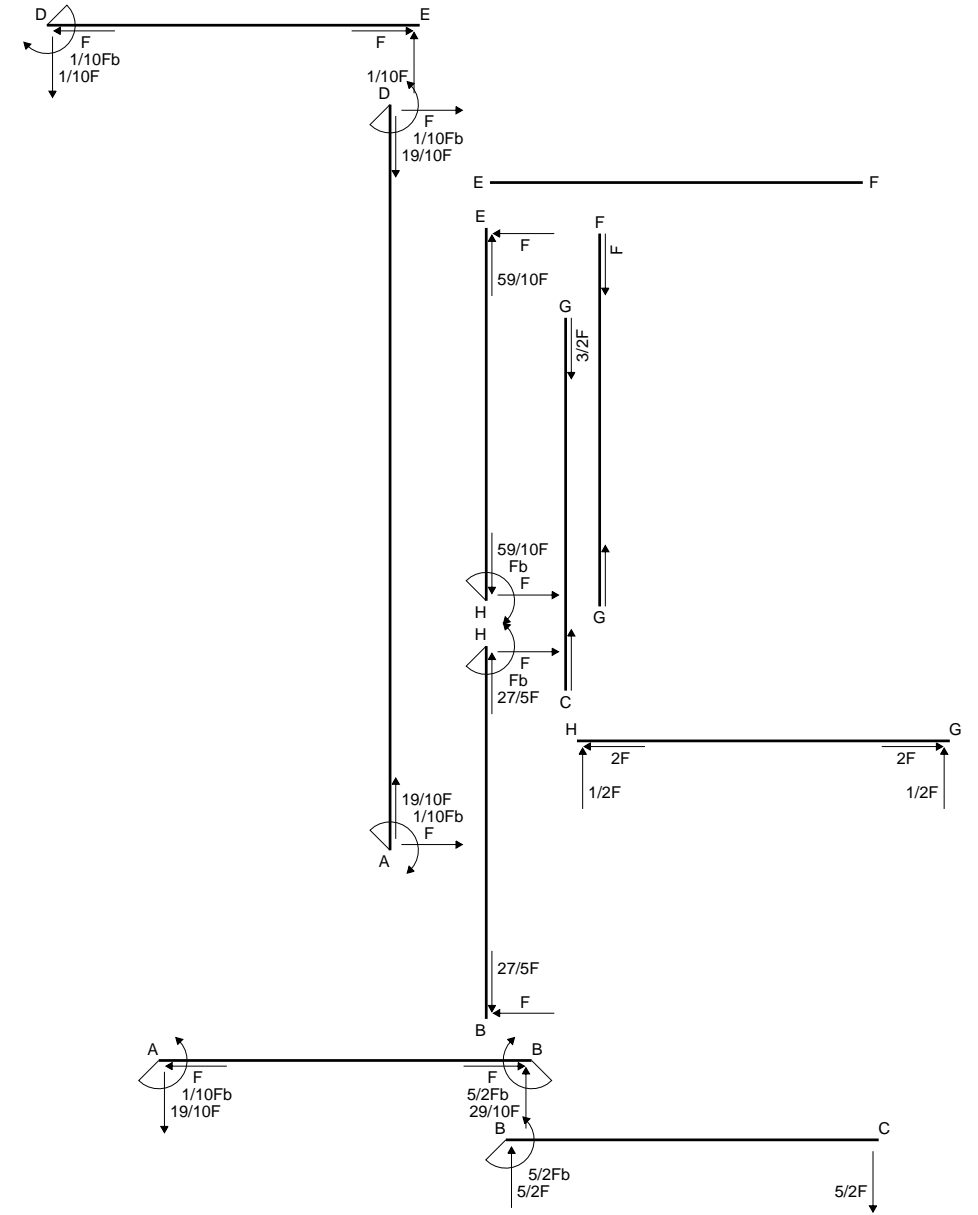

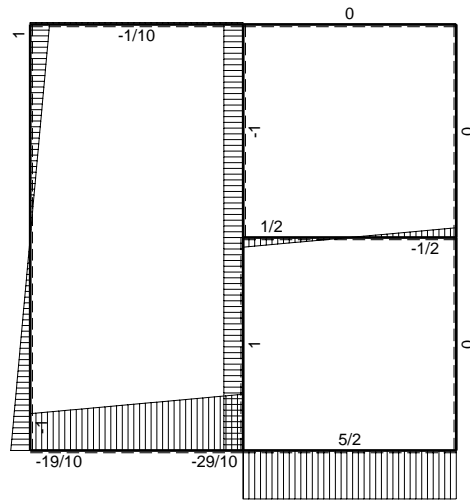
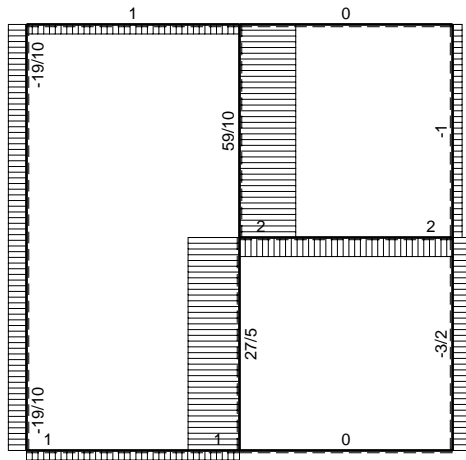

← ⊕ → F

↑ ⊕ ↓ F

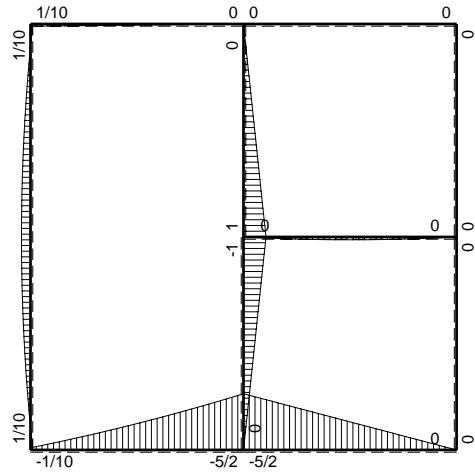

⊕ F_b

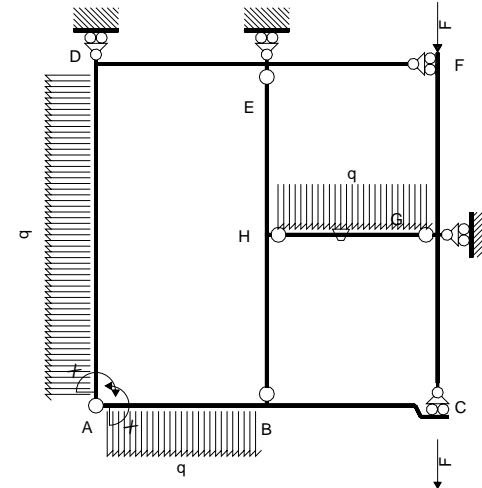

Schema di calcolo iperstatico

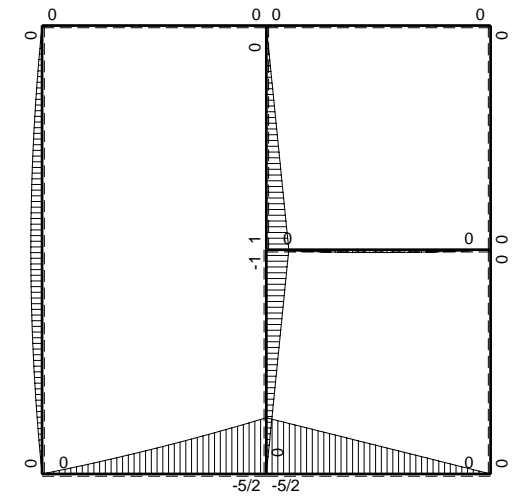

⊕ M₀ flessione da carichi assegnati

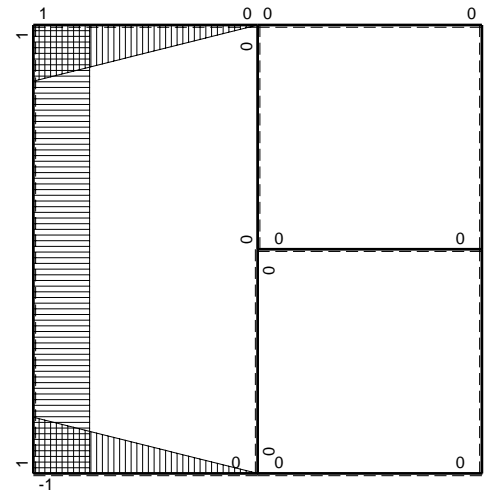

⊕ M_x flessione da iperstatica X=1

Quadro contributi PLV per iperstatica $X=W_{AB}$

→	$M_x(x)$	$M_o(x)$	θ	$M_x M_o$	$M_x \theta$	$M_x M_x$	$\int M_x(M_o/EJ+\theta)dx$	$\int X M_x M_x/EJ dx$	
AB b	$-1+x/b$	$-2Fx-1/2qx^2$	0	$2Fx-3/2Fx^2/b-1/2qx^3/b$	0	$1-2x/b+x^2/b^2$	$(3/8+0)Fb^2/EJ$	$1/3Xb/EJ$	
BA b	x/b	$5/2Fb-3Fx+1/2qx^2$	0	$5/2Fx-3Fx^2/b+1/2qx^3/b$	0	x^2/b^2			
BC b	0	$-5/2Fb+5/2Fx$	0	0	0	0	0+0	0	
CB b	0	$5/2Fx$	0	0	0	0			
AD 2b	1	$-Fx+1/2qx^2$	0	$-Fx+1/2Fx^2/b$	0	1	$(-2/3+0)Fb^2/EJ$	$2Xb/EJ$	
DA 2b	-1	$Fx-1/2qx^2$	0	$-Fx+1/2Fx^2/b$	0	1			
DE b	$1-x/b$	0	0	0	0	$1-2x/b+x^2/b^2$	0+0	$1/3Xb/EJ$	
ED b	$-x/b$	0	0	0	0	x^2/b^2			
EF b	0	0	0	0	0	0	0+0	0	
FE b	0	0	0	0	0	0			
FG b	0	0	0	0	0	0	0+0	0	
GF b	0	0	0	0	0	0			
GC b	0	0	0	0	0	0	0+0	0	
CG b	0	0	0	0	0	0			
HG b	0	$1/2Fx-1/2qx^2$	$-Fb/EJ$	0	0	0	0+0	0	
GH b	0	$-1/2Fx+1/2qx^2$	Fb/EJ	0	0	0			
HB b	0	$-Fb+Fx$	0	0	0	0	0+0	0	
BH b	0	Fx	0	0	0	0			
HE b	0	$Fb-Fx$	0	0	0	0	0+0	0	
EH b	0	$-Fx$	0	0	0	0			
AB	molla asta $-W_{1AB} (W_{0AB} + XW_{1AB})/k_{AB}$								$1/4Xb/EJ$
	totali							$-7/24Fb^2/EJ$	$35/12Xb/EJ$
	iperstatica $X=W_{AB}$							$1/10Fb$	

Sviluppi di calcolo iperstatica

$$L_{AB}^{xx} = \int_0^b (1 - 2x/b + x^2/b^2) \cdot 1/EJ \, dx + 1 \cdot 1/4 \cdot b/EJ = \left[x - x^2/b + 1/3 x^3/b^2 \right]_0^b \cdot 1/EJ + 1 \cdot 1/4 \cdot b/EJ$$

$$= (b - b + 1/3 b) \cdot 1/EJ + 1 \cdot 1/4 \cdot b/EJ = 7/12 \cdot b/EJ$$

$$L_{BA}^{xx} = \int_0^b (x^2/b^2) \cdot 1/EJ \, dx + 1 \cdot 1/4 \cdot b/EJ = \left[1/3 x^3/b^2 \right]_0^b \cdot 1/EJ + 1 \cdot 1/4 \cdot b/EJ$$

$$= (1/3 b) \cdot 1/EJ + 1 \cdot 1/4 \cdot b/EJ = 7/12 \cdot b/EJ$$

$$L_{AD}^{xx} = \int_0^{2b} (1) \cdot 1/EJ \, dx = \left[x \right]_0^{2b} \cdot 1/EJ$$

$$= (2b) \cdot 1/EJ = 2 \cdot b/EJ$$

$$L_{DA}^{xx} = \int_0^{2b} (1) \cdot 1/EJ \, dx = \left[x \right]_0^{2b} \cdot 1/EJ$$

$$= (2b) \cdot 1/EJ = 2 \cdot b/EJ$$

$$L_{DE}^{xx} = \int_0^b (1 - 2x/b + x^2/b^2) \cdot 1/EJ \, dx = \left[x - x^2/b + 1/3 x^3/b^2 \right]_0^b \cdot 1/EJ$$

$$= (b - b + 1/3 b) \cdot 1/EJ = 1/3 \cdot b/EJ$$

$$L_{ED}^{xx} = \int_0^b (x^2/b^2) \cdot 1/EJ \, dx = \left[1/3 x^3/b^2 \right]_0^b \cdot 1/EJ$$

$$= (1/3 b) \cdot 1/EJ = 1/3 \cdot b/EJ$$

$$L_{AB}^{xo} = \int_0^b (2x/b - 3/2 x^2/b^2 - 1/2 x^3/b^3) \cdot Fb \cdot 1/EJ \, dx + 1 \cdot 0 \cdot 1/4 \cdot Fb^2/EJ$$

$$= \left[x^2/b - 1/2 x^3/b^2 - 1/8 x^4/b^3 \right]_0^b \cdot Fb \cdot 1/EJ + 1 \cdot 0 \cdot 1/4 \cdot Fb^2/EJ$$

$$= (b - 1/2 b - 1/8 b) \cdot Fb \cdot 1/EJ + 1 \cdot 0 \cdot 1/4 \cdot Fb^2/EJ = 3/8 \cdot Fb^2/EJ$$

$$L_{BA}^{xo} = \int_0^b (5/2 x/b - 3 x^2/b^2 + 1/2 x^3/b^3) \cdot Fb \cdot 1/EJ \, dx + 1 \cdot 0 \cdot 1/4 \cdot Fb^2/EJ$$

$$= \left[5/4 x^2/b - x^3/b^2 + 1/8 x^4/b^3 \right]_0^b \cdot Fb \cdot 1/EJ + 1 \cdot 0 \cdot 1/4 \cdot Fb^2/EJ$$

$$= (5/4 b - b + 1/8 b) \cdot Fb \cdot 1/EJ + 1 \cdot 0 \cdot 1/4 \cdot Fb^2/EJ = 3/8 \cdot Fb^2/EJ$$

$$L_{AD}^{xo} = \int_0^{2b} (-x/b + 1/2 x^2/b^2) \cdot Fb \cdot 1/EJ \, dx = \left[-1/2 x^2/b + 1/6 x^3/b^2 \right]_0^{2b} \cdot Fb \cdot 1/EJ$$

$$= (-2b + 4/3 b) \cdot Fb \cdot 1/EJ = -2/3 \cdot Fb^2/EJ$$

$$L_{DA}^{xo} = \int_0^{2b} (-x/b + 1/2 x^2/b^2) \cdot Fb \cdot 1/EJ \, dx = \left[-1/2 x^2/b + 1/6 x^3/b^2 \right]_0^{2b} \cdot Fb \cdot 1/EJ$$

$$= (-2b + 4/3 b) \cdot Fb \cdot 1/EJ = -2/3 \cdot Fb^2/EJ$$

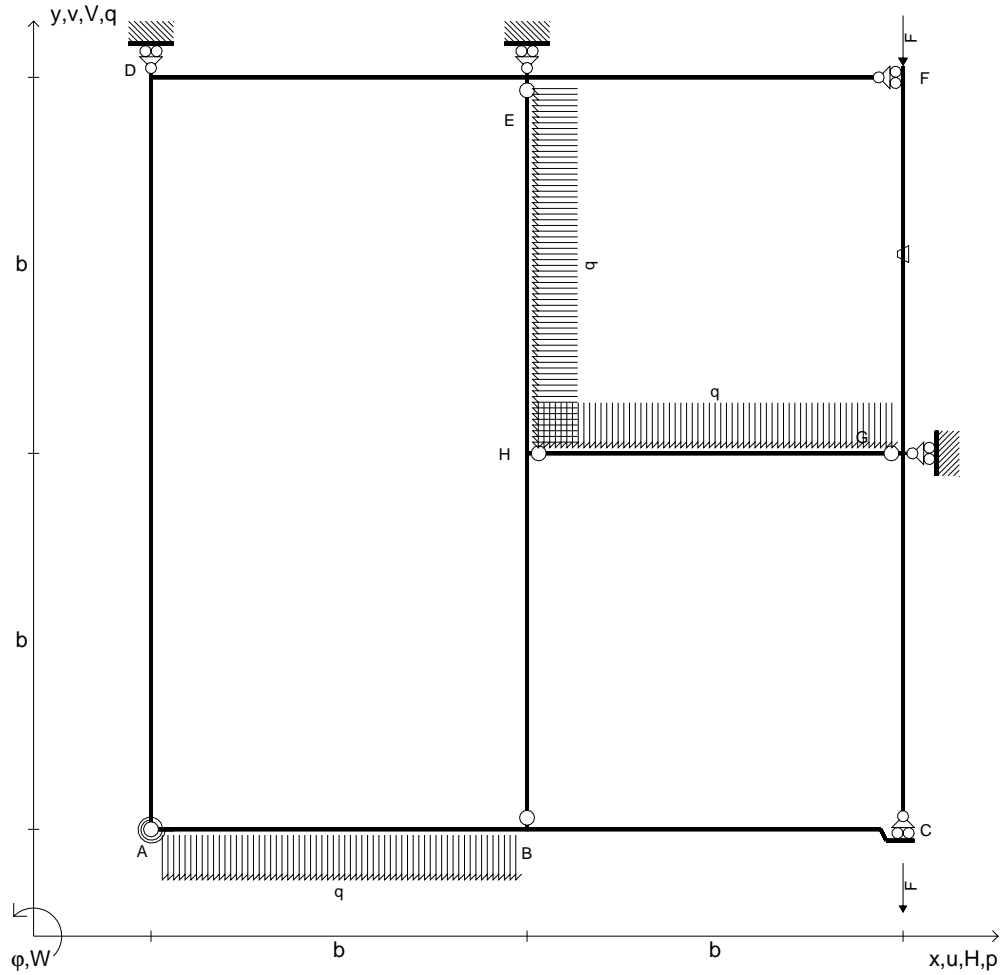

$V_{FG} = -F$	$k_{AB} = 4EJ/b$	$EJ_{FG} = EJ$
$V_{CB} = -F$	$EJ_{AB} = EJ$	$EJ_{GC} = EJ$
$q_{AB} = -q = -F/b$	$EJ_{BC} = EJ$	$EJ_{HG} = EJ$
$q_{HG} = -q = -F/b$	$EJ_{AD} = EJ$	$EJ_{HB} = EJ$
$p_{HE} = -q = -F/b$	$EJ_{DE} = EJ$	$EJ_{HE} = EJ$
$\theta_{FG} = -\theta = -\alpha T/b = -bF/EJ$	$EJ_{EF} = EJ$	

Reazioni iperstatiche in soluzione: $X=W_{AD}$
 Carichi e deformazioni date hanno verso efficace in disegno.
 Calcolare reazioni vincolari della struttura e delle aste.
 Tracciare i diagrammi quotati delle azioni interne nelle aste.
 $J_{YZ} - x_{YZ} - \theta_{YZ}$ riferimento locale asta YZ con origine in Y.
 Curvatura θ asta FG positiva se convessa a destra con inizio F.
 © Adolfo Zavelani Rossi, Politecnico di Milano, vers.27.03.13

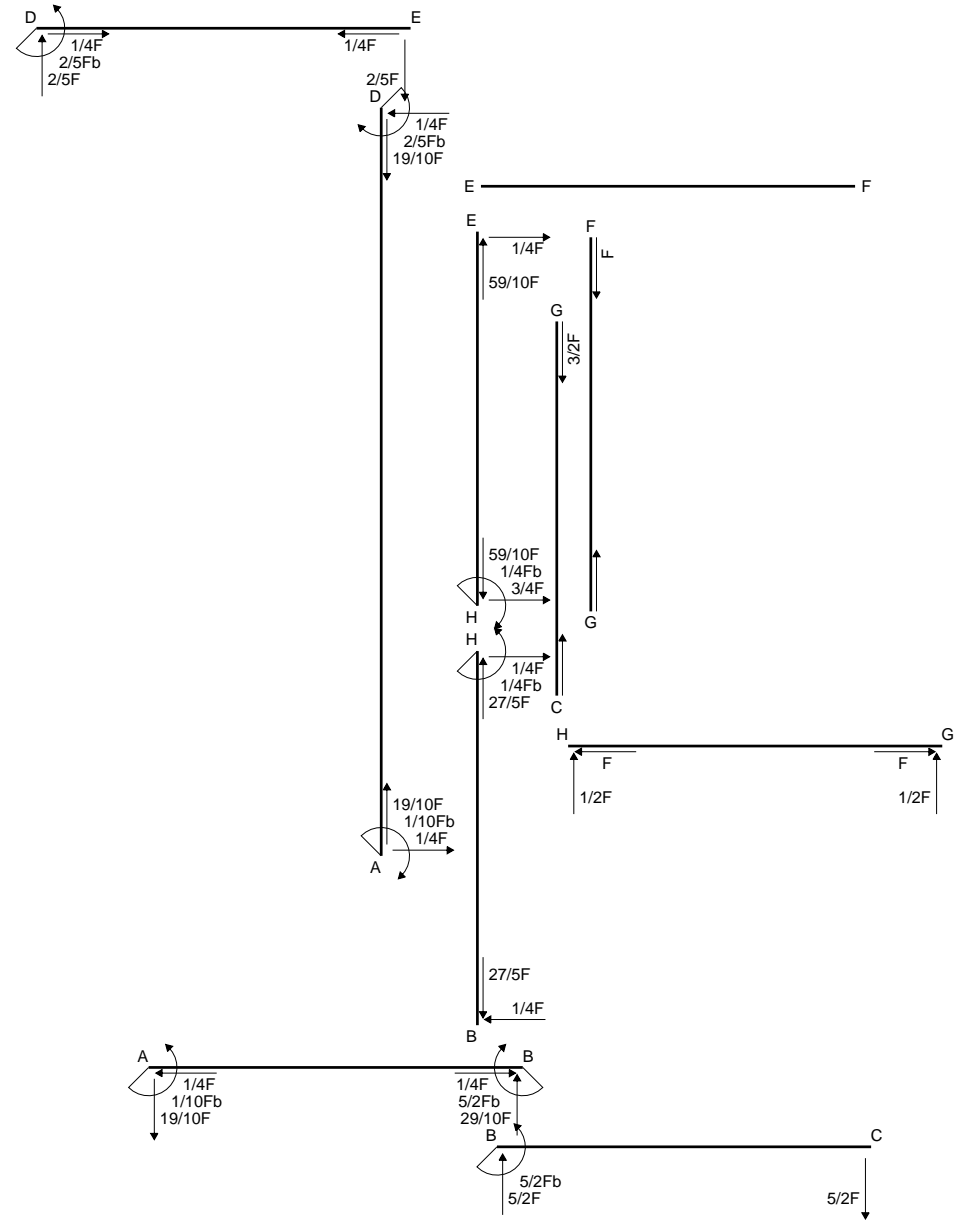

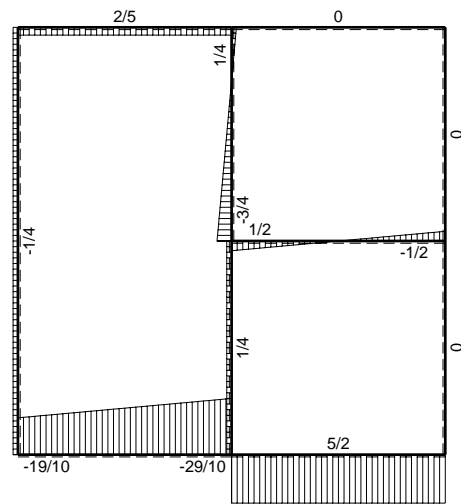
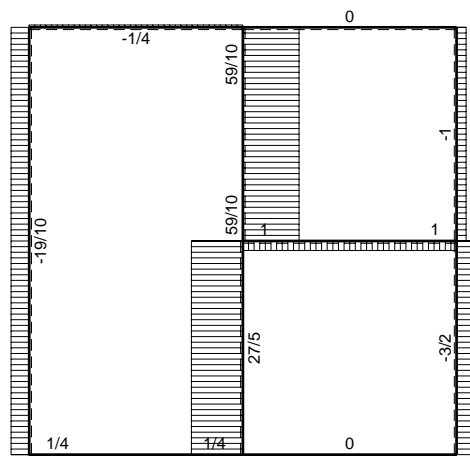

← (+) → F

↑ (+) ↓ F

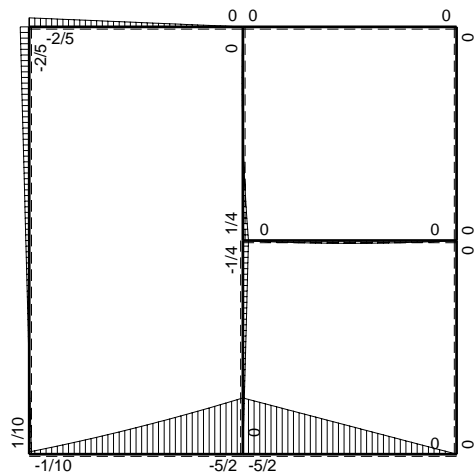

⊞ (+) ⊞ F_b

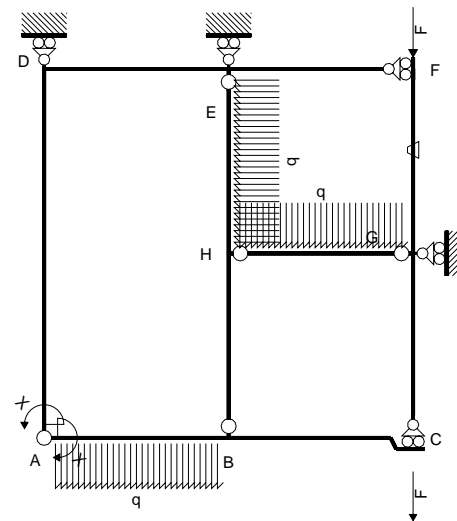

Schema di calcolo iperstatico

⊞ (+) ⊞ M_o flessione da carichi assegnati

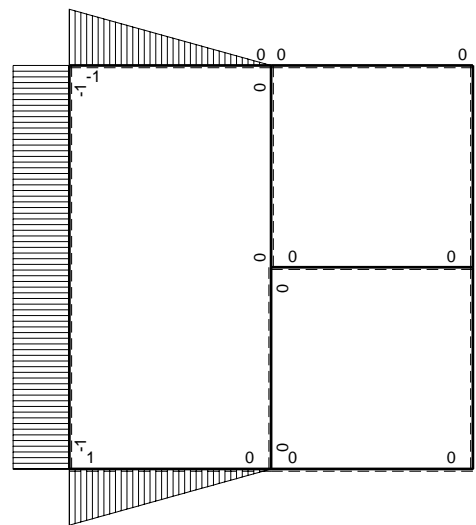

⊞ (+) ⊞ M_x flessione da iperstatica X=1

Quadro contributi PLV per iperstatica $X=W_{AD}$

→	$M_x(x)$	$M_o(x)$	θ	$M_x M_o$	$M_x \theta$	$M_x M_x$	$\int M_x(M_o/EJ+\theta)dx$	$\int X M_x M_x/EJ dx$	
AB b	$1-x/b$	$-2Fx-1/2qx^2$	0	$-2Fx+3/2Fx^2/b+1/2qx^3/b$	0	$1-2x/b+x^2/b^2$	$(-3/8+0)Fb^2/EJ$	$1/3Xb/EJ$	
BA b	$-x/b$	$5/2Fb-3Fx+1/2qx^2$	0	$-5/2Fx+3Fx^2/b-1/2qx^3/b$	0	x^2/b^2			
BC b	0	$-5/2Fb+5/2Fx$	0	0	0	0	0+0	0	
CB b	0	$5/2Fx$	0	0	0	0			
AD 2b	-1	$-1/4Fx$	0	$1/4Fx$	0	1	$(1/2+0)Fb^2/EJ$	$2Xb/EJ$	
DA 2b	1	$1/2Fb-1/4Fx$	0	$1/2Fb-1/4Fx$	0	1			
DE b	$-1+x/b$	$-1/2Fb+1/2Fx$	0	$1/2Fb-Fx+1/2Fx^2/b$	0	$1-2x/b+x^2/b^2$	$(1/6+0)Fb^2/EJ$	$1/3Xb/EJ$	
ED b	x/b	$1/2Fx$	0	$1/2Fx^2/b$	0	x^2/b^2			
EF b	0	0	0	0	0	0	0+0	0	
FE b	0	0	0	0	0	0			
FG b	0	0	$-Fb/EJ$	0	0	0	0+0	0	
GF b	0	0	Fb/EJ	0	0	0			
GC b	0	0	0	0	0	0	0+0	0	
CG b	0	0	0	0	0	0			
HG b	0	$1/2Fx-1/2qx^2$	0	0	0	0	0+0	0	
GH b	0	$-1/2Fx+1/2qx^2$	0	0	0	0			
HB b	0	$-1/4Fb+1/4Fx$	0	0	0	0	0+0	0	
BH b	0	$1/4Fx$	0	0	0	0			
HE b	0	$1/4Fb-3/4Fx+1/2qx^2$	0	0	0	0	0+0	0	
EH b	0	$1/4Fx-1/2qx^2$	0	0	0	0			
AB	molla asta $-W_{1AB}(W_{0AB}+XW_{1AB})/k_{AB}$								$1/4Xb/EJ$
	totali							$7/24Fb^2/EJ$	$35/12Xb/EJ$
	iperstatica $X=W_{AD}$							$-1/10Fb$	

Sviluppi di calcolo iperstatica

$$L_{AB}^{xx} = \int_0^b (1 - 2x/b + x^2/b^2) \cdot 1/EJ \, dx - 1 \cdot (-1) \cdot 1/4 \cdot b/EJ = \left[x - x^2/b + 1/3 x^3/b^2 \right]_0^b \cdot 1/EJ - 1 \cdot (-1) \cdot 1/4 \cdot b/EJ$$

$$= (b - b + 1/3 b) \cdot 1/EJ - 1 \cdot (-1) \cdot 1/4 \cdot b/EJ = 7/12 \cdot b/EJ$$

$$L_{BA}^{xx} = \int_0^b (x^2/b^2) \cdot 1/EJ \, dx - 1 \cdot (-1) \cdot 1/4 \cdot b/EJ = \left[1/3 x^3/b^2 \right]_0^b \cdot 1/EJ - 1 \cdot (-1) \cdot 1/4 \cdot b/EJ$$

$$= (1/3 b) \cdot 1/EJ - 1 \cdot (-1) \cdot 1/4 \cdot b/EJ = 7/12 \cdot b/EJ$$

$$L_{AD}^{xx} = \int_0^{2b} (1) \cdot 1/EJ \, dx = \left[x \right]_0^{2b} \cdot 1/EJ$$

$$= (2b) \cdot 1/EJ = 2 \cdot b/EJ$$

$$L_{DA}^{xx} = \int_0^{2b} (1) \cdot 1/EJ \, dx = \left[x \right]_0^{2b} \cdot 1/EJ$$

$$= (2b) \cdot 1/EJ = 2 \cdot b/EJ$$

$$L_{DE}^{xx} = \int_0^b (1 - 2x/b + x^2/b^2) \cdot 1/EJ \, dx = \left[x - x^2/b + 1/3 x^3/b^2 \right]_0^b \cdot 1/EJ$$

$$= (b - b + 1/3 b) \cdot 1/EJ = 1/3 \cdot b/EJ$$

$$L_{ED}^{xx} = \int_0^b (x^2/b^2) \cdot 1/EJ \, dx = \left[1/3 x^3/b^2 \right]_0^b \cdot 1/EJ$$

$$= (1/3 b) \cdot 1/EJ = 1/3 \cdot b/EJ$$

$$L_{AB}^{xo} = \int_0^b (-2x/b + 3/2 x^2/b^2 + 1/2 x^3/b^3) \cdot Fb \cdot 1/EJ \, dx - 1 \cdot 0 \cdot 1/4 \cdot Fb^2/EJ$$

$$= \left[-x^2/b + 1/2 x^3/b^2 + 1/8 x^4/b^3 \right]_0^b \cdot Fb \cdot 1/EJ - 1 \cdot 0 \cdot 1/4 \cdot Fb^2/EJ$$

$$= (-b + 1/2 b + 1/8 b) \cdot Fb \cdot 1/EJ - 1 \cdot 0 \cdot 1/4 \cdot Fb^2/EJ = -3/8 \cdot Fb^2/EJ$$

$$L_{BA}^{xo} = \int_0^b (-5/2 x/b + 3 x^2/b^2 - 1/2 x^3/b^3) \cdot Fb \cdot 1/EJ \, dx - 1 \cdot 0 \cdot 1/4 \cdot Fb^2/EJ$$

$$= \left[-5/4 x^2/b + x^3/b^2 - 1/8 x^4/b^3 \right]_0^b \cdot Fb \cdot 1/EJ - 1 \cdot 0 \cdot 1/4 \cdot Fb^2/EJ$$

$$= (-5/4 b + b - 1/8 b) \cdot Fb \cdot 1/EJ - 1 \cdot 0 \cdot 1/4 \cdot Fb^2/EJ = -3/8 \cdot Fb^2/EJ$$

$$L_{AD}^{xo} = \int_0^{2b} (1/4 x/b) \cdot Fb \cdot 1/EJ \, dx = \left[1/8 x^2/b \right]_0^{2b} \cdot Fb \cdot 1/EJ$$

$$= (1/2 b) \cdot Fb \cdot 1/EJ = 1/2 \cdot Fb^2/EJ$$

$$L_{DA}^{xo} = \int_0^{2b} (1/2 - 1/4 x/b) \cdot Fb \cdot 1/EJ \, dx = \left[1/2 x - 1/8 x^2/b \right]_0^{2b} \cdot Fb \cdot 1/EJ$$

$$= (b - 1/2 b) \cdot Fb \cdot 1/EJ = 1/2 \cdot Fb^2/EJ$$

$$L_{DE}^{xo} = \int_0^b (1/2 - x/b + 1/2 x^2/b^2) \cdot Fb \cdot 1/EJ \, dx = \left[1/2 x - 1/2 x^2/b + 1/6 x^3/b^2 \right]_0^b \cdot Fb \cdot 1/EJ$$

$$= (1/2 b - 1/2 b + 1/6 b) \cdot Fb \cdot 1/EJ = 1/6 \cdot Fb^2/EJ$$

$$L_{ED}^{xo} = \int_0^b (1/2 x^2/b^2) \cdot Fb \cdot 1/EJ \, dx = \left[1/6 x^3/b^2 \right]_0^b \cdot Fb \cdot 1/EJ$$

$$= (1/6 b) \cdot Fb \cdot 1/EJ = 1/6 \cdot Fb^2/EJ$$

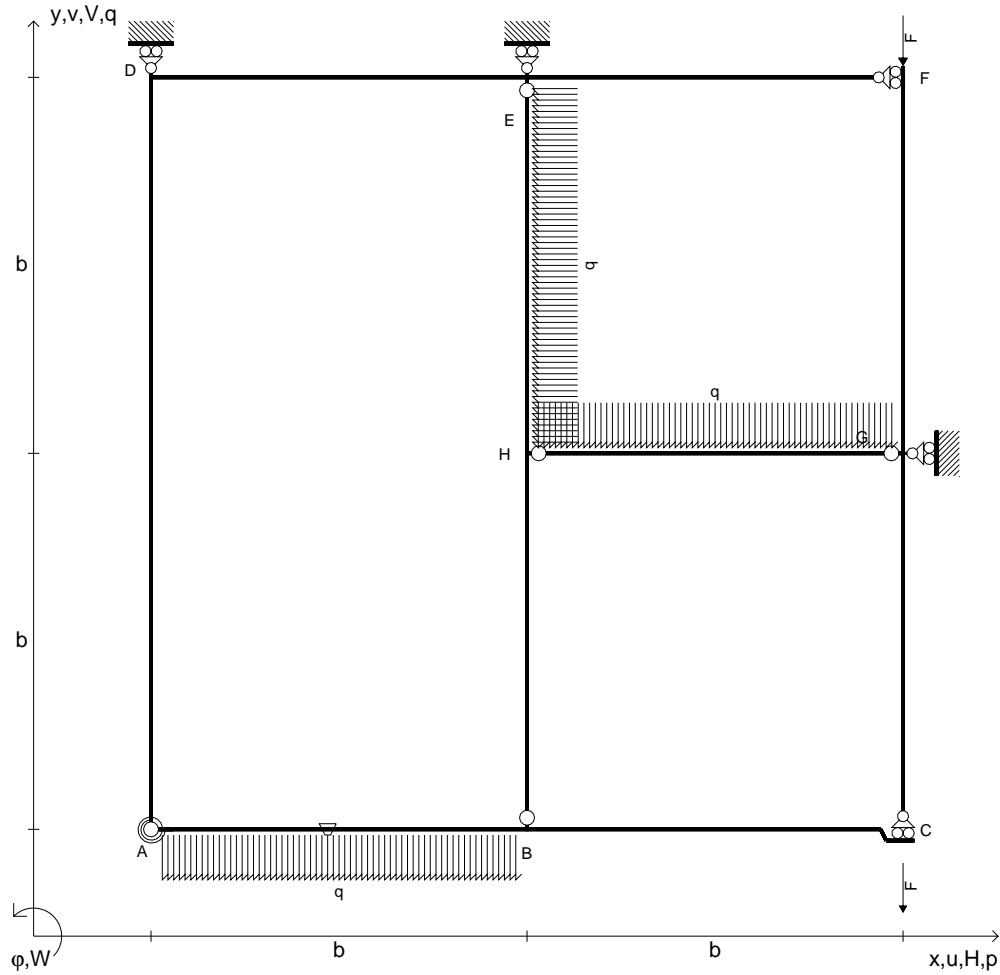

$V_{FG} = -F$	$k_{AB} = 4EJ/b$	$EJ_{FG} = EJ$
$V_{CB} = -F$	$EJ_{AB} = EJ$	$EJ_{GC} = EJ$
$q_{AB} = -q = -F/b$	$EJ_{BC} = EJ$	$EJ_{HG} = EJ$
$q_{HG} = -q = -F/b$	$EJ_{AD} = EJ$	$EJ_{HB} = EJ$
$p_{HE} = -q = -F/b$	$EJ_{DE} = EJ$	$EJ_{HE} = EJ$
$\theta_{AB} = -\theta = -\alpha T/b = -bF/EJ$	$EJ_{EF} = EJ$	

Reazioni iperstatiche in soluzione: $X=W_{DA}$
 Carichi e deformazioni date hanno verso efficace in disegno.
 Calcolare reazioni vincolari della struttura e delle aste.
 Tracciare i diagrammi quotati delle azioni interne nelle aste.
 $J_{YZ} - x_{YZ} - \theta_{YZ}$ riferimento locale asta YZ con origine in Y.
 Curvatura θ asta AB positiva se convessa a destra con inizio A.
 © Adolfo Zavelani Rossi, Politecnico di Milano, vers.27.03.13

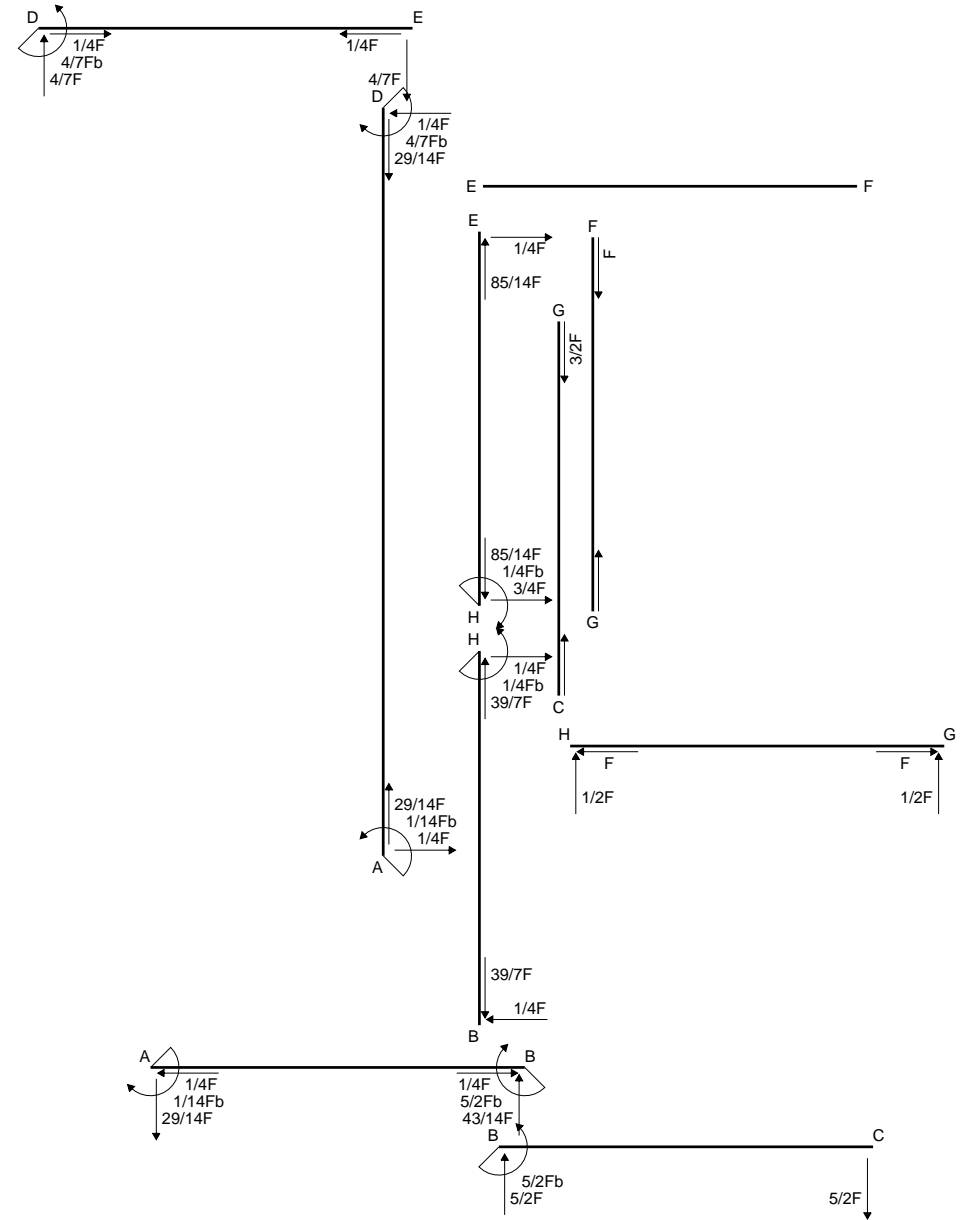

Quadro contributi PLV per iperstatica $X=W_{DA}$

→	$M_x(x)$	$M_0(x)$	θ	$M_x M_0$	$M_x \theta$	$M_x M_x$	$\int M_x(M_0/EJ+\theta)dx$	$\int X M_x M_x/EJdx$	
AB b	$-1+x/b$	$-1/2Fb-3/2Fx-1/2qx^2$	$-Fb/EJ$	$1/2Fb+Fx-Fx^2/b-1/2qx^3/b$	$Fb/EJ-Fx/EJ$	$1-2x/b+x^2/b^2$	$(13/24+1/2)Fb^2/EJ$	$1/3Xb/EJ$	
BA b	x/b	$5/2Fb-5/2Fx+1/2qx^2$	Fb/EJ	$5/2Fx-5/2Fx^2/b+1/2qx^3/b$	Fx/EJ	x^2/b^2			
BC b	0	$-5/2Fb+5/2Fx$	0	0	0	0	0+0	0	
CB b	0	$5/2Fx$	0	0	0	0			
AD 2b	1	$1/2Fb-1/4Fx$	0	$1/2Fb-1/4Fx$	0	1	$(1/2+0)Fb^2/EJ$	$2Xb/EJ$	
DA 2b	-1	$-1/4Fx$	0	$1/4Fx$	0	1			
DE b	$1-x/b$	0	0	0	0	$1-2x/b+x^2/b^2$	0+0	$1/3Xb/EJ$	
ED b	$-x/b$	0	0	0	0	x^2/b^2			
EF b	0	0	0	0	0	0	0+0	0	
FE b	0	0	0	0	0	0			
FG b	0	0	0	0	0	0	0+0	0	
GF b	0	0	0	0	0	0			
GC b	0	0	0	0	0	0	0+0	0	
CG b	0	0	0	0	0	0			
HG b	0	$1/2Fx-1/2qx^2$	0	0	0	0	0+0	0	
GH b	0	$-1/2Fx+1/2qx^2$	0	0	0	0			
HB b	0	$-1/4Fb+1/4Fx$	0	0	0	0	0+0	0	
BH b	0	$1/4Fx$	0	0	0	0			
HE b	0	$1/4Fb-3/4Fx+1/2qx^2$	0	0	0	0	0+0	0	
EH b	0	$1/4Fx-1/2qx^2$	0	0	0	0			
AB	molla asta $-W_{1AB}(W_{0AB}+XW_{1AB})/k_{AB}$							$1/8Fb^2/EJ$	$1/4Xb/EJ$
	totali							$5/3Fb^2/EJ$	$35/12Xb/EJ$
	iperstatica $X=W_{DA}$							$-4/7Fb$	

Sviluppi di calcolo iperstatica

$$L_{AB}^{xx} = \int_0^b (1 - 2x/b + x^2/b^2) \cdot 1/EJ \, dx + 1 \cdot 1/4 \cdot b/EJ = \left[x - x^2/b + 1/3 x^3/b^2 \right]_0^b \cdot 1/EJ + 1 \cdot 1/4 \cdot b/EJ$$

$$= (b - b + 1/3 b) \cdot 1/EJ + 1 \cdot 1/4 \cdot b/EJ = 7/12 \cdot b/EJ$$

$$L_{BA}^{xx} = \int_0^b (x^2/b^2) \cdot 1/EJ \, dx + 1 \cdot 1/4 \cdot b/EJ = \left[1/3 x^3/b^2 \right]_0^b \cdot 1/EJ + 1 \cdot 1/4 \cdot b/EJ$$

$$= (1/3 b) \cdot 1/EJ + 1 \cdot 1/4 \cdot b/EJ = 7/12 \cdot b/EJ$$

$$L_{AD}^{xx} = \int_0^{2b} (1) \cdot 1/EJ \, dx = \left[x \right]_0^{2b} \cdot 1/EJ$$

$$= (2b) \cdot 1/EJ = 2 \cdot b/EJ$$

$$L_{DA}^{xx} = \int_0^{2b} (1) \cdot 1/EJ \, dx = \left[x \right]_0^{2b} \cdot 1/EJ$$

$$= (2b) \cdot 1/EJ = 2 \cdot b/EJ$$

$$L_{DE}^{xx} = \int_0^b (1 - 2x/b + x^2/b^2) \cdot 1/EJ \, dx = \left[x - x^2/b + 1/3 x^3/b^2 \right]_0^b \cdot 1/EJ$$

$$= (b - b + 1/3 b) \cdot 1/EJ = 1/3 \cdot b/EJ$$

$$L_{ED}^{xx} = \int_0^b (x^2/b^2) \cdot 1/EJ \, dx = \left[1/3 x^3/b^2 \right]_0^b \cdot 1/EJ$$

$$= (1/3 b) \cdot 1/EJ = 1/3 \cdot b/EJ$$

$$L_{AB}^{xo} = \int_0^b (1/2 + x/b - x^2/b^2 - 1/2 x^3/b^3) \cdot Fb \cdot 1/EJ \, dx + \int_0^b (1 - x/b) \cdot \theta \, dx + 1 \cdot 1/2 \cdot 1/4 \cdot Fb^2/EJ$$

$$= \left[1/2 x + 1/2 x^2/b - 1/3 x^3/b^2 - 1/8 x^4/b^3 \right]_0^b \cdot Fb \cdot 1/EJ + \left[x - 1/2 x^2/b \right]_0^b \cdot \theta + 1 \cdot 1/2 \cdot 1/4 \cdot Fb^2/EJ$$

$$= (1/2 b + 1/2 b - 1/3 b - 1/8 b) \cdot Fb \cdot 1/EJ + (b - 1/2 b) \cdot \theta + 1 \cdot 1/2 \cdot 1/4 \cdot Fb^2/EJ = 7/6 \cdot Fb^2/EJ$$

$$L_{BA}^{xo} = \int_0^b (5/2 x/b - 5/2 x^2/b^2 + 1/2 x^3/b^3) \cdot Fb \cdot 1/EJ \, dx + \int_0^b (-x/b) \cdot \theta \, dx + 1 \cdot 1/2 \cdot 1/4 \cdot Fb^2/EJ$$

$$= \left[5/4 x^2/b - 5/6 x^3/b^2 + 1/8 x^4/b^3 \right]_0^b \cdot Fb \cdot 1/EJ + \left[-1/2 x^2/b \right]_0^b \cdot \theta + 1 \cdot 1/2 \cdot 1/4 \cdot Fb^2/EJ$$

$$= (5/4 b - 5/6 b + 1/8 b) \cdot Fb \cdot 1/EJ + (-1/2 b) \cdot \theta + 1 \cdot 1/2 \cdot 1/4 \cdot Fb^2/EJ = 7/6 \cdot Fb^2/EJ$$

$$L_{AD}^{xo} = \int_0^{2b} (1/2 - 1/4 x/b) \cdot Fb \cdot 1/EJ \, dx = \left[1/2 x - 1/8 x^2/b \right]_0^{2b} \cdot Fb \cdot 1/EJ$$

$$= (b - 1/2 b) \cdot Fb \cdot 1/EJ = 1/2 \cdot Fb^2/EJ$$

$$L_{DA}^{xo} = \int_0^{2b} (1/4 x/b) \cdot Fb \cdot 1/EJ \, dx = \left[1/8 x^2/b \right]_0^{2b} \cdot Fb \cdot 1/EJ$$

$$= (1/2 b) \cdot Fb \cdot 1/EJ = 1/2 \cdot Fb^2/EJ$$

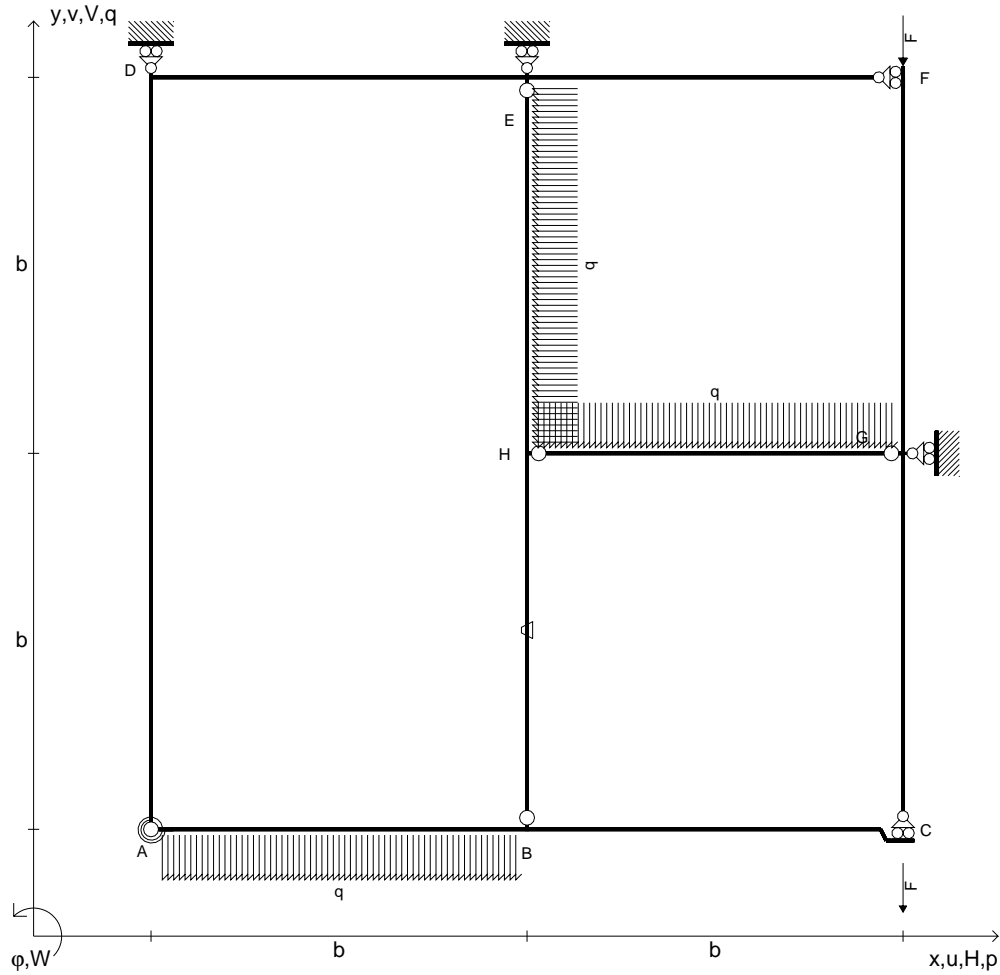

$V_{FG} = -F$	$k_{AB} = 4EJ/b$	$EJ_{FG} = EJ$
$V_{CB} = -F$	$EJ_{AB} = EJ$	$EJ_{GC} = EJ$
$q_{AB} = -q = -F/b$	$EJ_{BC} = EJ$	$EJ_{HG} = EJ$
$q_{HG} = -q = -F/b$	$EJ_{AD} = EJ$	$EJ_{HB} = EJ$
$p_{HE} = -q = -F/b$	$EJ_{DE} = EJ$	$EJ_{HE} = EJ$
$\theta_{HB} = -\theta = -\alpha T/b = -bF/EJ$	$EJ_{EF} = EJ$	

Reazioni iperstatiche in soluzione: $X=W_{DA}$
 Carichi e deformazioni date hanno verso efficace in disegno.
 Calcolare reazioni vincolari della struttura e delle aste.
 Tracciare i diagrammi quotati delle azioni interne nelle aste.
 $J_{YZ} - x_{YZ} - \theta_{YZ}$ riferimento locale asta YZ con origine in Y.
 Curvatura θ asta HB positiva se convessa a destra con inizio H.
 © Adolfo Zavelani Rossi, Politecnico di Milano, vers.27.03.13

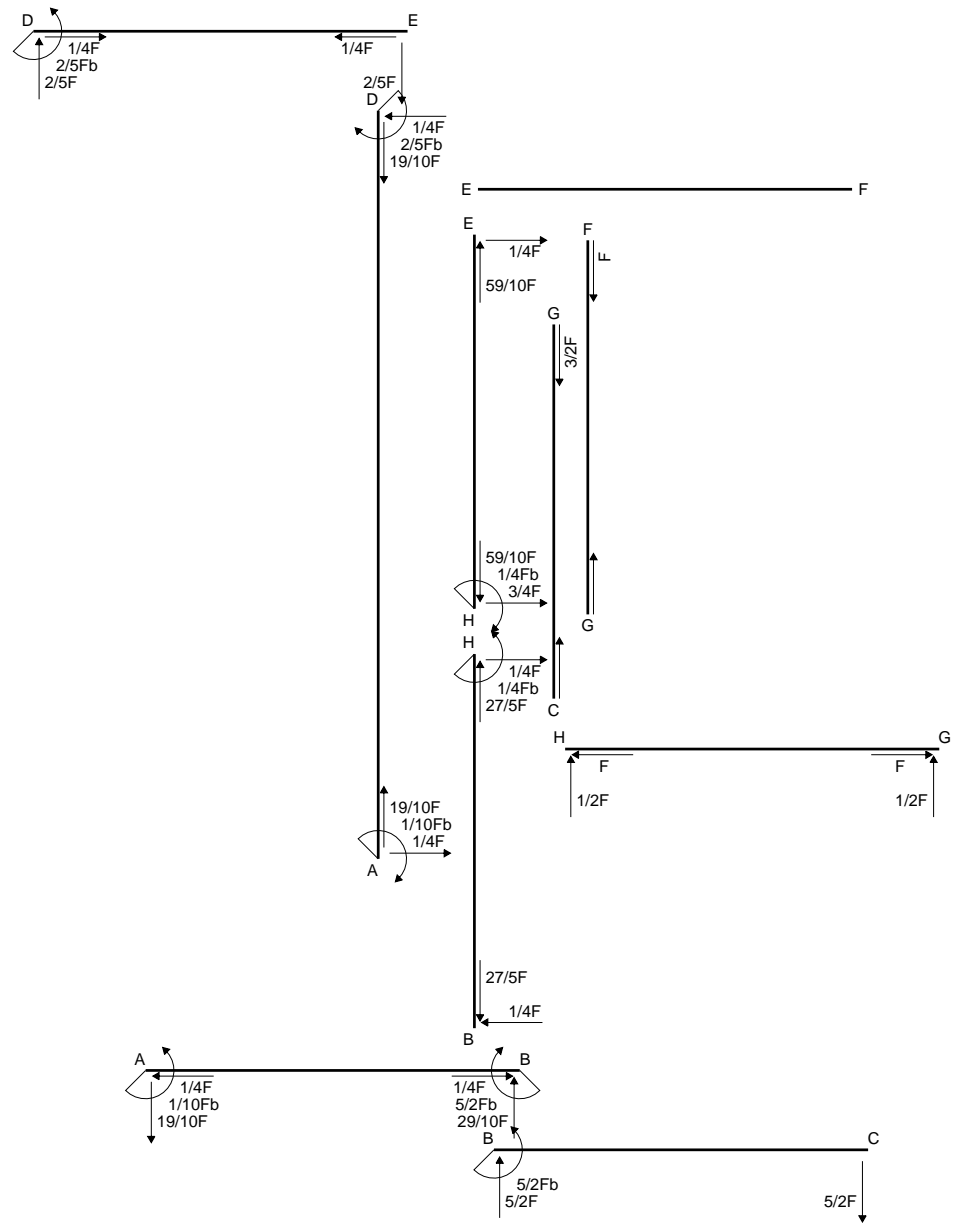

Quadro contributi PLV per iperstatica $X=W_{DA}$

→	$M_x(x)$	$M_o(x)$	θ	$M_x M_o$	$M_x \theta$	$M_x M_x$	$\int M_x(M_o/EJ+\theta)dx$	$\int X M_x M_x/EJ dx$	
AB b	$-1+x/b$	$-1/2Fb-3/2Fx-1/2qx^2$	0	$1/2Fb+Fx-Fx^2/b-1/2qx^3/b$	0	$1-2x/b+x^2/b^2$	$(13/24+0)Fb^2/EJ$	$1/3Xb/EJ$	
BA b	x/b	$5/2Fb-5/2Fx+1/2qx^2$	0	$5/2Fx-5/2Fx^2/b+1/2qx^3/b$	0	x^2/b^2			
BC b	0	$-5/2Fb+5/2Fx$	0	0	0	0	0+0	0	
CB b	0	$5/2Fx$	0	0	0	0			
AD 2b	1	$1/2Fb-1/4Fx$	0	$1/2Fb-1/4Fx$	0	1	$(1/2+0)Fb^2/EJ$	$2Xb/EJ$	
DA 2b	-1	$-1/4Fx$	0	$1/4Fx$	0	1			
DE b	$1-x/b$	0	0	0	0	$1-2x/b+x^2/b^2$	0+0	$1/3Xb/EJ$	
ED b	$-x/b$	0	0	0	0	x^2/b^2			
EF b	0	0	0	0	0	0	0+0	0	
FE b	0	0	0	0	0	0			
FG b	0	0	0	0	0	0	0+0	0	
GF b	0	0	0	0	0	0			
GC b	0	0	0	0	0	0	0+0	0	
CG b	0	0	0	0	0	0			
HG b	0	$1/2Fx-1/2qx^2$	0	0	0	0	0+0	0	
GH b	0	$-1/2Fx+1/2qx^2$	0	0	0	0			
HB b	0	$-1/4Fb+1/4Fx$	$-Fb/EJ$	0	0	0	0+0	0	
BH b	0	$1/4Fx$	Fb/EJ	0	0	0			
HE b	0	$1/4Fb-3/4Fx+1/2qx^2$	0	0	0	0	0+0	0	
EH b	0	$1/4Fx-1/2qx^2$	0	0	0	0			
AB	molla asta $-W_{1AB} \setminus (W_{0AB}+XW_{1AB})/k_{AB}$							$1/8Fb^2/EJ$	$1/4Xb/EJ$
	totali							$7/6Fb^2/EJ$	$35/12Xb/EJ$
	iperstatica $X=W_{DA}$							$-2/5Fb$	

Sviluppi di calcolo iperstatica

$$L_{AB}^{xx} = \int_0^b (1 - 2x/b + x^2/b^2) \cdot 1/EJ \, dx + 1 \cdot 1/4 \cdot b/EJ = \left[x - x^2/b + 1/3 x^3/b^2 \right]_0^b \cdot 1/EJ + 1 \cdot 1/4 \cdot b/EJ$$

$$= (b - b + 1/3 b) \cdot 1/EJ + 1 \cdot 1/4 \cdot b/EJ = 7/12 \cdot b/EJ$$

$$L_{BA}^{xx} = \int_0^b (x^2/b^2) \cdot 1/EJ \, dx + 1 \cdot 1/4 \cdot b/EJ = \left[1/3 x^3/b^2 \right]_0^b \cdot 1/EJ + 1 \cdot 1/4 \cdot b/EJ$$

$$= (1/3 b) \cdot 1/EJ + 1 \cdot 1/4 \cdot b/EJ = 7/12 \cdot b/EJ$$

$$L_{AD}^{xx} = \int_0^{2b} (1) \cdot 1/EJ \, dx = \left[x \right]_0^{2b} \cdot 1/EJ$$

$$= (2b) \cdot 1/EJ = 2 \cdot b/EJ$$

$$L_{DA}^{xx} = \int_0^{2b} (1) \cdot 1/EJ \, dx = \left[x \right]_0^{2b} \cdot 1/EJ$$

$$= (2b) \cdot 1/EJ = 2 \cdot b/EJ$$

$$L_{DE}^{xx} = \int_0^b (1 - 2x/b + x^2/b^2) \cdot 1/EJ \, dx = \left[x - x^2/b + 1/3 x^3/b^2 \right]_0^b \cdot 1/EJ$$

$$= (b - b + 1/3 b) \cdot 1/EJ = 1/3 \cdot b/EJ$$

$$L_{ED}^{xx} = \int_0^b (x^2/b^2) \cdot 1/EJ \, dx = \left[1/3 x^3/b^2 \right]_0^b \cdot 1/EJ$$

$$= (1/3 b) \cdot 1/EJ = 1/3 \cdot b/EJ$$

$$L_{AB}^{xo} = \int_0^b (1/2 + x/b - x^2/b^2 - 1/2 x^3/b^3) \cdot Fb \cdot 1/EJ \, dx + 1 \cdot 1/2 \cdot 1/4 \cdot Fb^2/EJ$$

$$= \left[1/2 x + 1/2 x^2/b - 1/3 x^3/b^2 - 1/8 x^4/b^3 \right]_0^b \cdot Fb \cdot 1/EJ + 1 \cdot 1/2 \cdot 1/4 \cdot Fb^2/EJ$$

$$= (1/2 b + 1/2 b - 1/3 b - 1/8 b) \cdot Fb \cdot 1/EJ + 1 \cdot 1/2 \cdot 1/4 \cdot Fb^2/EJ = 2/3 \cdot Fb^2/EJ$$

$$L_{BA}^{xo} = \int_0^b (5/2 x/b - 5/2 x^2/b^2 + 1/2 x^3/b^3) \cdot Fb \cdot 1/EJ \, dx + 1 \cdot 1/2 \cdot 1/4 \cdot Fb^2/EJ$$

$$= \left[5/4 x^2/b - 5/6 x^3/b^2 + 1/8 x^4/b^3 \right]_0^b \cdot Fb \cdot 1/EJ + 1 \cdot 1/2 \cdot 1/4 \cdot Fb^2/EJ$$

$$= (5/4 b - 5/6 b + 1/8 b) \cdot Fb \cdot 1/EJ + 1 \cdot 1/2 \cdot 1/4 \cdot Fb^2/EJ = 2/3 \cdot Fb^2/EJ$$

$$L_{AD}^{xo} = \int_0^{2b} (1/2 - 1/4 x/b) \cdot Fb \cdot 1/EJ \, dx = \left[1/2 x - 1/8 x^2/b \right]_0^{2b} \cdot Fb \cdot 1/EJ$$

$$= (b - 1/2 b) \cdot Fb \cdot 1/EJ = 1/2 \cdot Fb^2/EJ$$

$$L_{DA}^{xo} = \int_0^{2b} (1/4 x/b) \cdot Fb \cdot 1/EJ \, dx = \left[1/8 x^2/b \right]_0^{2b} \cdot Fb \cdot 1/EJ$$

$$= (1/2 b) \cdot Fb \cdot 1/EJ = 1/2 \cdot Fb^2/EJ$$