

- $H_{FB} = -F$
- $V_D = -F$
- $W_C = -W = -Fb$
- $W_G = -W = -Fb$
- $W_E = -W = -Fb$
- $p_{GA} = -q = -F/b$
- $p_{EF} = -q = -F/b$
- $q_{EF} = -q = -F/b$
- $\epsilon_{BE} = -\alpha T = -b^2 F/EJ$
- $K_C = 4EJ/b^3$
- $EJ_{AB} = EJ$
- $EJ_{BC} = EJ$
- $EJ_{CD} = EJ$
- $EJ_{DE} = EJ$
- $EJ_{EF} = EJ$
- $EJ_{FG} = EJ$
- $EJ_{GA} = EJ$
- $EJ_{FB} = EJ$
- $EJ_{BE} = EJ$

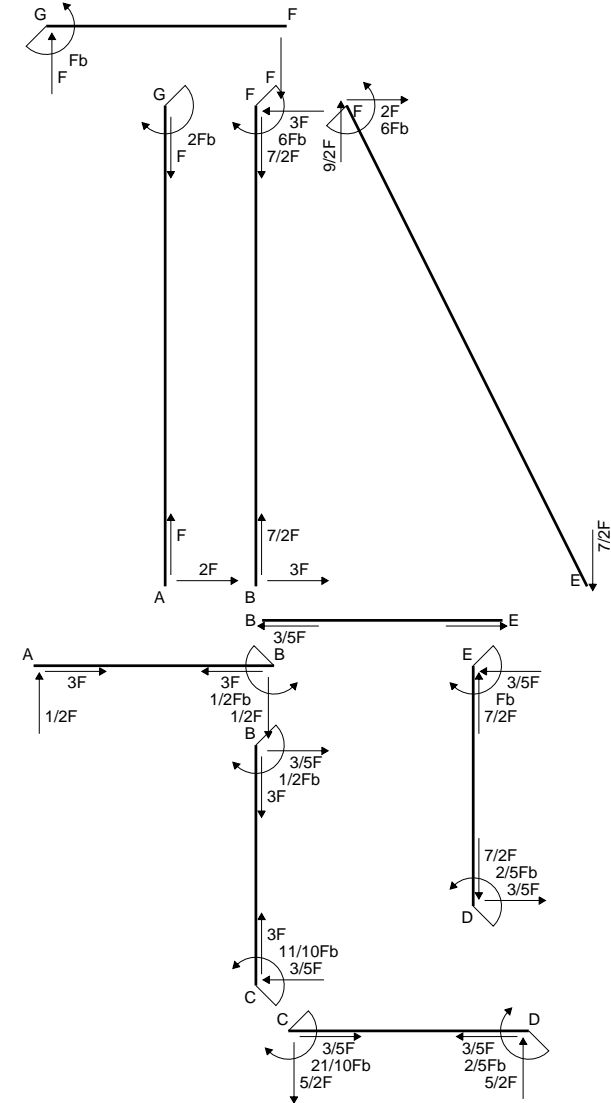
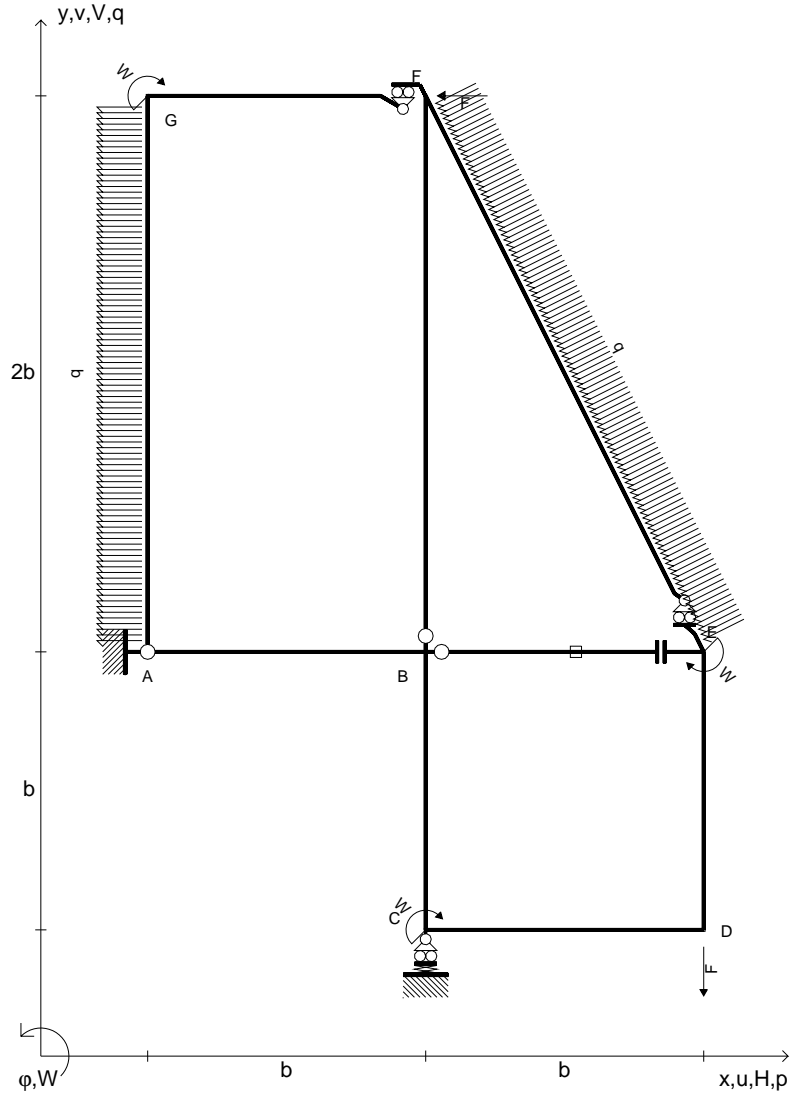

Reazioni iperstatiche in soluzione: $X=W_{DE}$
 Carichi e deformazioni date hanno verso efficace in disegno.
 Calcolare reazioni vincolari della struttura e delle aste.
 Tracciare i diagrammi quotati delle azioni interne nelle aste.
 Diagrammi di carico con valori riferiti ad asse della trave.
 Componenti di carico distribuito riferiti ad assi ortogonali.
 $J_{YZ} - x_{YZ} - \theta_{YZ}$ riferimento locale asta YZ con origine in Y.
 Elongazione termica specifica ϵ assegnata su asta BE.
 © Adolfo Zavelani Rossi, Politecnico di Milano, vers.27.03.13

Quadro contributi PLV per iperstatica $X=W_{DE}$

→	$M_x(x)$	$M_o(x)$	$M_x M_o$	$M_x M_x$	$\int M_x M_o / EJ dx$	$\int X M_x M_x / EJ dx$
AB b	0	1/2Fx	0	0	0	0
BA b	0	-1/2Fb+1/2Fx	0	0	0	0
BC b	-x/b	1/2Fb+Fx	-1/2Fx-Fx ² /b	x ² /b ²	-7/12Fb ² /EJ	1/3Xb/EJ
CB b	1-x/b	-3/2Fb+Fx	-3/2Fb+5/2Fx-Fx ² /b	1-2x/b+x ² /b ²	-5/4Fb ² /EJ	Xb/EJ
CD b	-1	5/2Fb-5/2Fx	-5/2Fb+5/2Fx	1	-5/4Fb ² /EJ	Xb/EJ
DC b	1	-5/2Fx	-5/2Fx	1	-5/4Fb ² /EJ	Xb/EJ
DE b	-1+x/b	-Fx	Fx-Fx ² /b	1-2x/b+x ² /b ²	1/6Fb ² /EJ	1/3Xb/EJ
ED b	x/b	Fb-Fx	Fx-Fx ² /b	x ² /b ²	1/6Fb ² /EJ	1/3Xb/EJ
EF √5b	0	7√5/10Fx+1/2qx ²	0	0	0	0
FG b	0	Fx	0	0	0	0
GF b	0	-Fb+Fx	0	0	0	0
GA 2b	0	2Fb-1/2qx ²	0	0	0	0
AG 2b	0	-2Fx+1/2qx ²	0	0	0	0
FB 2b	0	6Fb-3Fx	0	0	0	0
BF 2b	0	-3Fx	0	0	0	0
BE b	0	0	0	0	0	0
EB b	0	0	0	0	0	0
BE	elongazione asta $N_{1BE} \epsilon_{BE} L_{BE}$				Fb ² /EJ	
	totali				-2/3Fb ² /EJ	5/3Xb/EJ
	iperstatica $X=W_{DE}$				2/5Fb	

Sviluppi di calcolo iperstatica

$$L_{BC}^{xx} = \int_0^b (x^2/b^2) 1/EJ dx = [1/3 x^3/b^2]_0^b 1/EJ = (1/3 b) 1/EJ = 1/3 b/EJ$$

$$L_{CB}^{xx} = \int_0^b (1 - 2x/b + x^2/b^2) 1/EJ dx = [x - x^2/b + 1/3 x^3/b^2]_0^b 1/EJ = (b - b + 1/3 b) 1/EJ = 1/3 b/EJ$$

$$L_{CD}^{xx} = \int_0^b (1) 1/EJ dx = [x]_0^b 1/EJ = (b) 1/EJ = b/EJ$$

$$L_{DC}^{xx} = \int_0^b (1) 1/EJ dx = [x]_0^b 1/EJ = (b) 1/EJ = b/EJ$$

$$L_{DE}^{xx} = \int_0^b (1 - 2x/b + x^2/b^2) 1/EJ dx = [x - x^2/b + 1/3 x^3/b^2]_0^b 1/EJ = (b - b + 1/3 b) 1/EJ = 1/3 b/EJ$$

$$L_{ED}^{xx} = \int_0^b (x^2/b^2) 1/EJ dx = [1/3 x^3/b^2]_0^b 1/EJ = (1/3 b) 1/EJ = 1/3 b/EJ$$

$$L_{BC}^{xo} = \int_0^b (-1/2 x/b - x^2/b^2) Fb 1/EJ dx = [-1/4 x^2/b - 1/3 x^3/b^2]_0^b Fb 1/EJ = (-1/4 b - 1/3 b) Fb 1/EJ = -7/12 Fb^2/EJ$$

$$L_{CB}^{xo} = \int_0^b (-3/2 + 5/2 x/b - x^2/b^2) Fb 1/EJ dx = [-3/2 x + 5/4 x^2/b - 1/3 x^3/b^2]_0^b Fb 1/EJ = (-3/2 b + 5/4 b - 1/3 b) Fb 1/EJ = -7/12 Fb^2/EJ$$

$$L_{CD}^{xo} = \int_0^b (-5/2 + 5/2 x/b) Fb 1/EJ dx = [-5/2 x + 5/4 x^2/b]_0^b Fb 1/EJ = (-5/2 b + 5/4 b) Fb 1/EJ = -5/4 Fb^2/EJ$$

$$L_{DC}^{xo} = \int_0^b (-5/2 x/b) Fb 1/EJ dx = [-5/4 x^2/b]_0^b Fb 1/EJ = (-5/4 b) Fb 1/EJ = -5/4 Fb^2/EJ$$

$$L_{DE}^{xo} = \int_0^b (x/b - x^2/b^2) Fb 1/EJ dx = [1/2 x^2/b - 1/3 x^3/b^2]_0^b Fb 1/EJ = (1/2 b - 1/3 b) Fb 1/EJ = 1/6 Fb^2/EJ$$

$$L_{ED}^{xo} = \int_0^b (x/b - x^2/b^2) Fb 1/EJ dx = [1/2 x^2/b - 1/3 x^3/b^2]_0^b Fb 1/EJ = (1/2 b - 1/3 b) Fb 1/EJ = 1/6 Fb^2/EJ$$

Quadro contributi PLV per iperstatica $X=W_{DE}$

→	$M_x(x)$	$M_o(x)$	$M_x M_o$	$M_x M_x$	$\int M_x M_o / EJ dx$	$\int X M_x M_x / EJ dx$
AB b	0	-Fx	0	0	0	0
BA b	0	Fb-Fx	0	0	0	0
BC b	-x/b	-Fb+Fx	Fx-Fx ² /b	x ² /b ²	1/6Fb ² /EJ	1/3Xb/EJ
CB b	1-x/b	Fx	Fx-Fx ² /b	1-2x/b+x ² /b ²	1/6Fb ² /EJ	1/3Xb/EJ
CD b	-1	Fb-Fx	-Fb+Fx	1	-1/2Fb ² /EJ	Xb/EJ
DC b	1	-Fx	-Fx	1	-1/2Fb ² /EJ	Xb/EJ
DE b	-1+x/b	-Fx	Fx-Fx ² /b	1-2x/b+x ² /b ²	1/6Fb ² /EJ	1/3Xb/EJ
ED b	x/b	Fb-Fx	Fx-Fx ² /b	x ² /b ²	1/6Fb ² /EJ	1/3Xb/EJ
EF √5b	0	2√5/5Fx	0	0	0	0
FG b	0	1/2Fx+1/2qx ²	0	0	0	0
GF b	0	-Fb+3/2Fx-1/2qx ²	0	0	0	0
GA 2b	0	2Fb-1/2qx ²	0	0	0	0
AG 2b	0	-2Fx+1/2qx ²	0	0	0	0
FB 2b	0	2Fb-Fx	0	0	0	0
BF 2b	0	-Fx	0	0	0	0
BE b	0	0	0	0	0	0
EB b	0	0	0	0	0	0
BE	elongazione asta $N_{1BE} \epsilon_{BE} L_{BE}$				Fb ² /EJ	
	totali				5/6Fb ² /EJ	5/3Xb/EJ
	iperstatica $X=W_{DE}$				-1/2Fb	

Sviluppi di calcolo iperstatica

$$L_{BC}^{xx} = \int_0^b (x^2/b^2) 1/EJ dx = [1/3 x^3/b^2]_0^b 1/EJ = (1/3 b) 1/EJ = 1/3 b/EJ$$

$$L_{CB}^{xx} = \int_0^b (1 - 2x/b + x^2/b^2) 1/EJ dx = [x - x^2/b + 1/3 x^3/b^2]_0^b 1/EJ = (b - b + 1/3 b) 1/EJ = 1/3 b/EJ$$

$$L_{CD}^{xx} = \int_0^b (1) 1/EJ dx = [x]_0^b 1/EJ = (b) 1/EJ = b/EJ$$

$$L_{DC}^{xx} = \int_0^b (1) 1/EJ dx = [x]_0^b 1/EJ = (b) 1/EJ = b/EJ$$

$$L_{DE}^{xx} = \int_0^b (1 - 2x/b + x^2/b^2) 1/EJ dx = [x - x^2/b + 1/3 x^3/b^2]_0^b 1/EJ = (b - b + 1/3 b) 1/EJ = 1/3 b/EJ$$

$$L_{ED}^{xx} = \int_0^b (x^2/b^2) 1/EJ dx = [1/3 x^3/b^2]_0^b 1/EJ = (1/3 b) 1/EJ = 1/3 b/EJ$$

$$L_{BC}^{xo} = \int_0^b (x/b - x^2/b^2) Fb 1/EJ dx = [1/2 x^2/b - 1/3 x^3/b^2]_0^b Fb 1/EJ = (1/2 b - 1/3 b) Fb 1/EJ = 1/6 Fb^2/EJ$$

$$L_{CB}^{xo} = \int_0^b (x/b - x^2/b^2) Fb 1/EJ dx = [1/2 x^2/b - 1/3 x^3/b^2]_0^b Fb 1/EJ = (1/2 b - 1/3 b) Fb 1/EJ = 1/6 Fb^2/EJ$$

$$L_{CD}^{xo} = \int_0^b (-1 + x/b) Fb 1/EJ dx = [-x + 1/2 x^2/b]_0^b Fb 1/EJ = (-b + 1/2 b) Fb 1/EJ = -1/2 Fb^2/EJ$$

$$L_{DC}^{xo} = \int_0^b (-x/b) Fb 1/EJ dx = [-1/2 x^2/b]_0^b Fb 1/EJ = (-1/2 b) Fb 1/EJ = -1/2 Fb^2/EJ$$

$$L_{DE}^{xo} = \int_0^b (x/b - x^2/b^2) Fb 1/EJ dx = [1/2 x^2/b - 1/3 x^3/b^2]_0^b Fb 1/EJ = (1/2 b - 1/3 b) Fb 1/EJ = 1/6 Fb^2/EJ$$

$$L_{ED}^{xo} = \int_0^b (x/b - x^2/b^2) Fb 1/EJ dx = [1/2 x^2/b - 1/3 x^3/b^2]_0^b Fb 1/EJ = (1/2 b - 1/3 b) Fb 1/EJ = 1/6 Fb^2/EJ$$

- $H_{FB} = -F$
- $V_D = -F$
- $W_C = -W = -Fb$
- $W_G = -W = -Fb$
- $W_E = -W = -Fb$
- $p_{EF} = -q = -F/b$
- $q_{EF} = -q = -F/b$
- $q_{BE} = -q = -F/b$
- $\epsilon_{CD} = -\alpha T = -b^2 F/EJ$
- $k_C = 4EJ/b^3$
- $EJ_{AB} = EJ$
- $EJ_{BC} = EJ$
- $EJ_{CD} = EJ$
- $EJ_{DE} = EJ$
- $EJ_{EF} = EJ$
- $EJ_{FG} = EJ$
- $EJ_{GA} = EJ$
- $EJ_{FB} = EJ$
- $EJ_{BE} = EJ$

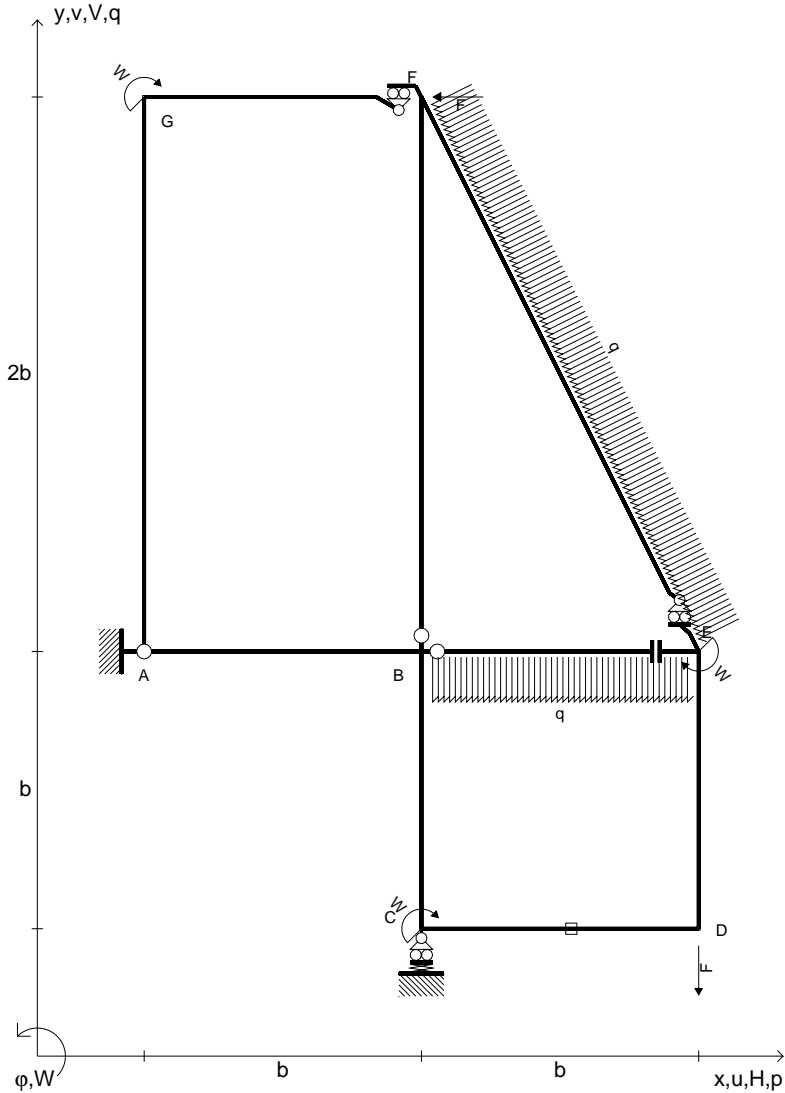

Reazioni iperstatiche in soluzione: $X=W_{DE}$
 Carichi e deformazioni date hanno verso efficace in disegno.
 Calcolare reazioni vincolari della struttura e delle aste.
 Tracciare i diagrammi quotati delle azioni interne nelle aste.
 Diagrammi di carico con valori riferiti ad asse della trave.
 Componenti di carico distribuito riferiti ad assi ortogonali.
 $J_{YZ} - x_{YZ} - \theta_{YZ}$ riferimento locale asta YZ con origine in Y.
 Elongazione termica specifica ϵ assegnata su asta CD.
 © Adolfo Zavelani Rossi, Politecnico di Milano, vers.27.03.13

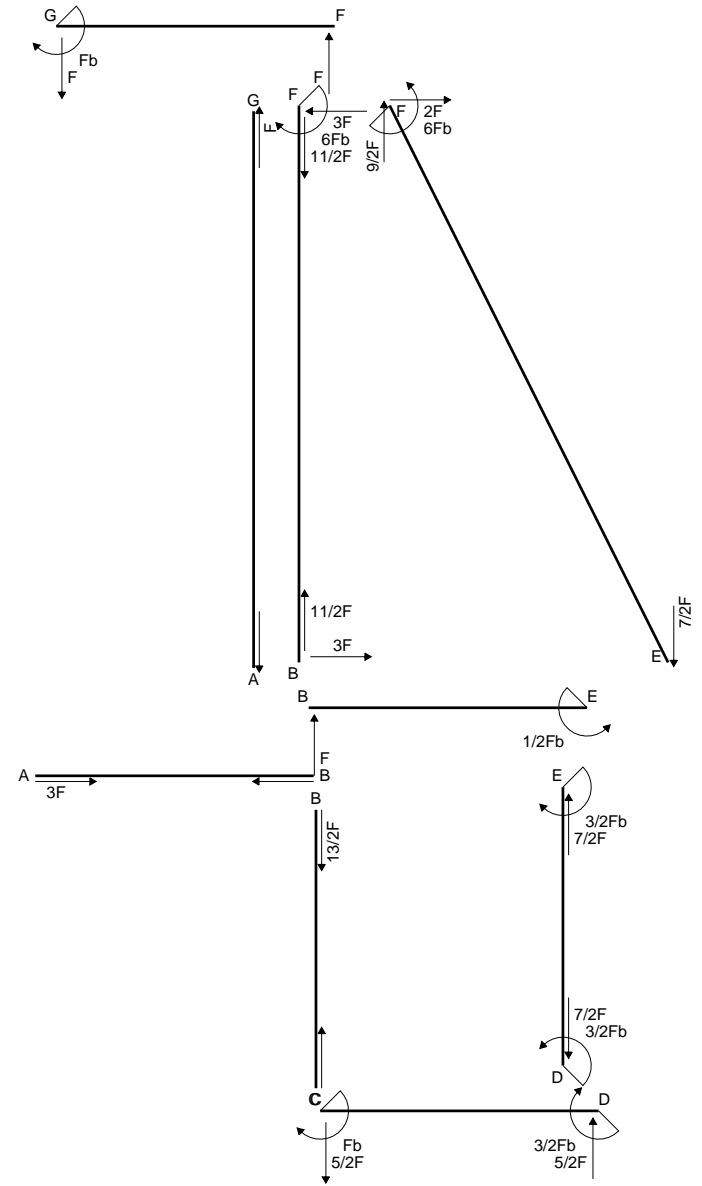

Quadro contributi PLV per iperstatica X=W_{DE}

→	M _x (x)	M _o (x)	M _x M _o	M _x M _x	∫M _x M _o /EJdx	∫XM _x M _x /EJdx
AB b	0	0	0	0	0	0
BA b	0	0	0	0		
BC b	-x/b	3/2Fx	-3/2Fx ² /b	x ² /b ²	-1/2Fb ² /EJ	1/3Xb/EJ
CB b	1-x/b	-3/2Fb+3/2Fx	-3/2Fb+3Fx-3/2Fx ² /b	1-2x/b+x ² /b ²		
CD b	-1	5/2Fb-5/2Fx	-5/2Fb+5/2Fx	1	-5/4Fb ² /EJ	Xb/EJ
DC b	1	-5/2Fx	-5/2Fx	1		
DE b	-1+x/b	-3/2Fx	3/2Fx-3/2Fx ² /b	1-2x/b+x ² /b ²	1/4Fb ² /EJ	1/3Xb/EJ
ED b	x/b	3/2Fb-3/2Fx	3/2Fx-3/2Fx ² /b	x ² /b ²		
EF √5b	0	7√5/10Fx+1/2qx ²	0	0	0	0
FG b	0	-Fx	0	0	0	0
GF b	0	Fb-Fx	0	0		
GA 2b	0	0	0	0	0	0
AG 2b	0	0	0	0		
FB 2b	0	6Fb-3Fx	0	0	0	0
BF 2b	0	-3Fx	0	0		
BE b	0	Fx-1/2qx ²	0	0	0	0
EB b	0	-1/2Fb+1/2qx ²	0	0		
CD	elongazione asta N _{1CD} ε _{CD} L _{CD}				-Fb ² /EJ	
	totali				-5/2Fb ² /EJ	5/3Xb/EJ
	iperstatica X=W _{DE}				3/2Fb	

Sviluppi di calcolo iperstatica

$$L_{BC}^{xx} = \int_0^b (x^2/b^2) 1/EJ dx = [1/3 x^3/b^2]_0^b 1/EJ = (1/3 b) 1/EJ = 1/3 b/EJ$$

$$L_{CB}^{xx} = \int_0^b (1 - 2x/b + x^2/b^2) 1/EJ dx = [x - x^2/b + 1/3 x^3/b^2]_0^b 1/EJ = (b - b + 1/3 b) 1/EJ = 1/3 b/EJ$$

$$L_{CD}^{xx} = \int_0^b (1) 1/EJ dx = [x]_0^b 1/EJ = (b) 1/EJ = b/EJ$$

$$L_{DC}^{xx} = \int_0^b (1) 1/EJ dx = [x]_0^b 1/EJ = (b) 1/EJ = b/EJ$$

$$L_{DE}^{xx} = \int_0^b (1 - 2x/b + x^2/b^2) 1/EJ dx = [x - x^2/b + 1/3 x^3/b^2]_0^b 1/EJ = (b - b + 1/3 b) 1/EJ = 1/3 b/EJ$$

$$L_{ED}^{xx} = \int_0^b (x^2/b^2) 1/EJ dx = [1/3 x^3/b^2]_0^b 1/EJ = (1/3 b) 1/EJ = 1/3 b/EJ$$

$$L_{BC}^{xo} = \int_0^b (-3/2 x^2/b^2) Fb 1/EJ dx = [-1/2 x^3/b^2]_0^b Fb 1/EJ = (-1/2 b) Fb 1/EJ = -1/2 Fb^2/EJ$$

$$L_{CB}^{xo} = \int_0^b (-3/2 + 3x/b - 3/2 x^2/b^2) Fb 1/EJ dx = [-3/2 x + 3/2 x^2/b - 1/2 x^3/b^2]_0^b Fb 1/EJ = (-3/2 b + 3/2 b - 1/2 b) Fb 1/EJ = -1/2 Fb^2/EJ$$

$$L_{CD}^{xo} = \int_0^b (-5/2 + 5/2 x/b) Fb 1/EJ dx + 1 (-1) 1 Fb^2/EJ = [-5/2 x + 5/4 x^2/b]_0^b Fb 1/EJ + 1 (-1) 1 Fb^2/EJ = (-5/2 b + 5/4 b) Fb 1/EJ + 1 (-1) 1 Fb^2/EJ = -9/4 Fb^2/EJ$$

$$L_{DC}^{xo} = \int_0^b (-5/2 x/b) Fb 1/EJ dx + 1 (-1) 1 Fb^2/EJ = [-5/4 x^2/b]_0^b Fb 1/EJ + 1 (-1) 1 Fb^2/EJ = (-5/4 b) Fb 1/EJ + 1 (-1) 1 Fb^2/EJ = -9/4 Fb^2/EJ$$

$$L_{DE}^{xo} = \int_0^b (3/2 x/b - 3/2 x^2/b^2) Fb 1/EJ dx = [3/4 x^2/b - 1/2 x^3/b^2]_0^b Fb 1/EJ = (3/4 b - 1/2 b) Fb 1/EJ = 1/4 Fb^2/EJ$$

$$L_{ED}^{xo} = \int_0^b (3/2 x/b - 3/2 x^2/b^2) Fb 1/EJ dx = [3/4 x^2/b - 1/2 x^3/b^2]_0^b Fb 1/EJ = (3/4 b - 1/2 b) Fb 1/EJ = 1/4 Fb^2/EJ$$

- $H_{FB} = -F$
- $V_D = -F$
- $W_C = -W = -Fb$
- $W_G = -W = -Fb$
- $W_E = -W = -Fb$
- $p_{EF} = -q = -F/b$
- $q_{EF} = -q = -F/b$
- $p_{GA} = -q = -F/b$
- $\epsilon_{CD} = -\alpha T = -b^2 F/EJ$
- $K_C = 4EJ/b^3$
- $EJ_{AB} = EJ$
- $EJ_{BC} = EJ$
- $EJ_{CD} = EJ$
- $EJ_{DE} = EJ$
- $EJ_{EF} = EJ$
- $EJ_{FG} = EJ$
- $EJ_{GA} = EJ$
- $EJ_{FB} = EJ$
- $EJ_{BE} = EJ$

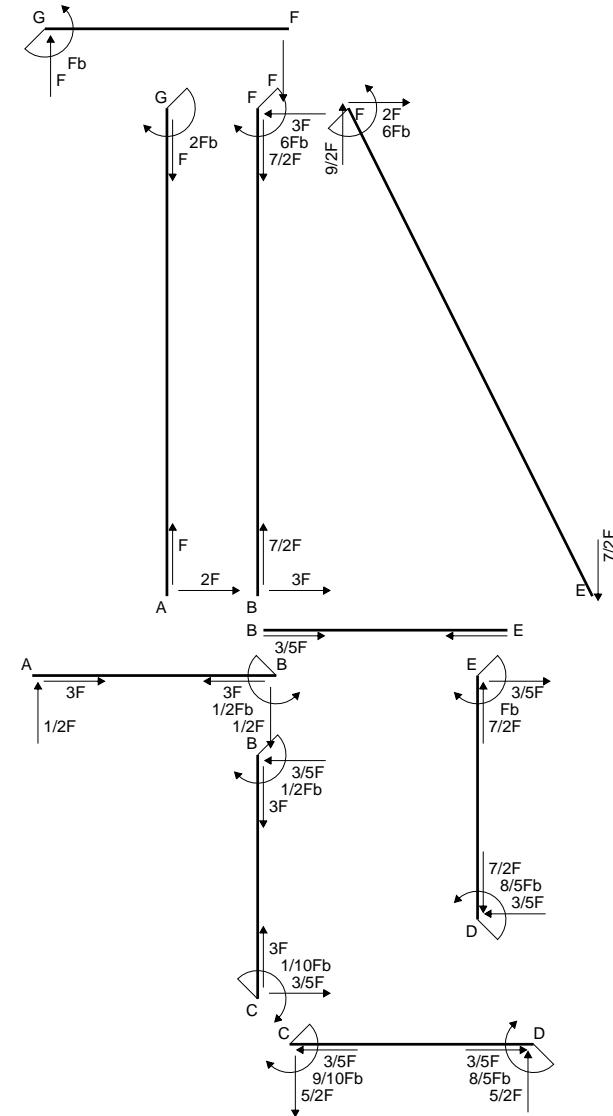
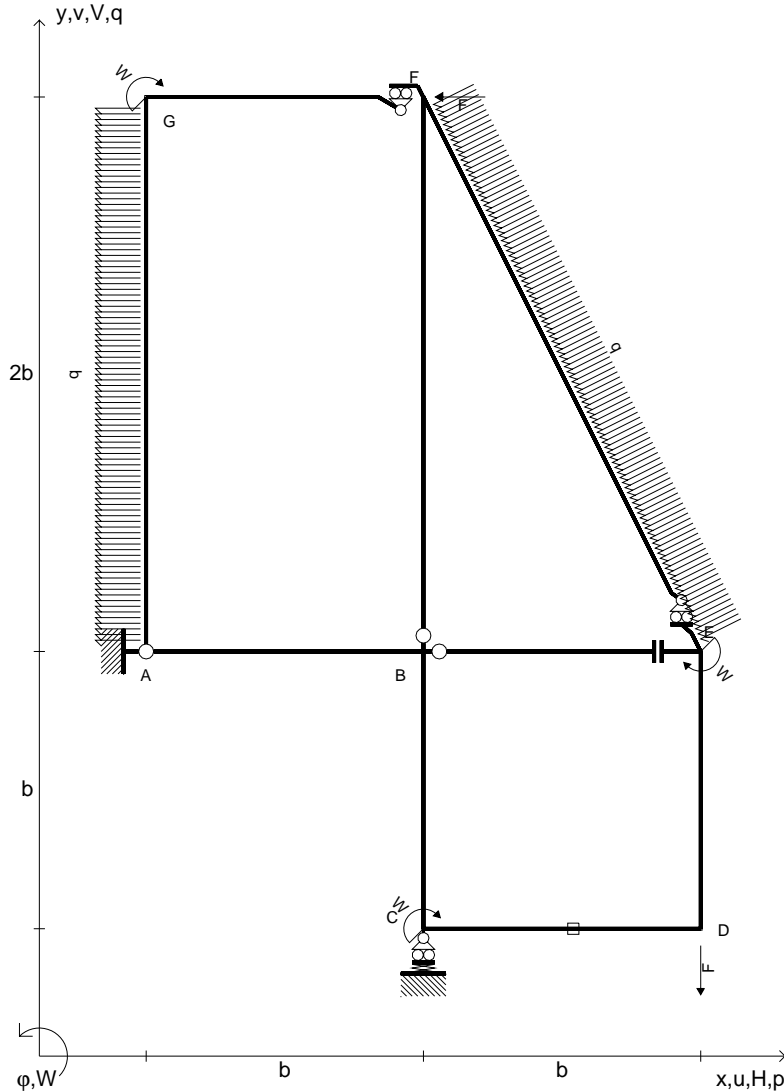

Reazioni iperstatiche in soluzione: $X=W_{DE}$
 Carichi e deformazioni date hanno verso efficace in disegno.
 Calcolare reazioni vincolari della struttura e delle aste.
 Tracciare i diagrammi quotati delle azioni interne nelle aste.
 Diagrammi di carico con valori riferiti ad asse della trave.
 Componenti di carico distribuito riferiti ad assi ortogonali.
 $J_{YZ} - x_{YZ} - \theta_{YZ}$ riferimento locale asta YZ con origine in Y.
 Elongazione termica specifica ϵ assegnata su asta CD.
 © Adolfo Zavelani Rossi, Politecnico di Milano, vers.27.03.13

Quadro contributi PLV per iperstatica X=W_{DE}

→	M _x (x)	M _o (x)	M _x M _o	M _x M _x	∫M _x M _o /EJdx	∫XM _x M _x /EJdx
AB b	0	1/2Fx	0	0	0	0
BA b	0	-1/2Fb+1/2Fx	0	0	0	0
BC b	-x/b	1/2Fb+Fx	-1/2Fx-Fx ² /b	x ² /b ²	-7/12Fb ² /EJ	1/3Xb/EJ
CB b	1-x/b	-3/2Fb+Fx	-3/2Fb+5/2Fx-Fx ² /b	1-2x/b+x ² /b ²	-5/4Fb ² /EJ	Xb/EJ
CD b	-1	5/2Fb-5/2Fx	-5/2Fb+5/2Fx	1	-5/4Fb ² /EJ	Xb/EJ
DC b	1	-5/2Fx	-5/2Fx	1	-5/4Fb ² /EJ	Xb/EJ
DE b	-1+x/b	-Fx	Fx-Fx ² /b	1-2x/b+x ² /b ²	1/6Fb ² /EJ	1/3Xb/EJ
ED b	x/b	Fb-Fx	Fx-Fx ² /b	x ² /b ²	1/6Fb ² /EJ	1/3Xb/EJ
EF √5b	0	7√5/10Fx+1/2qx ²	0	0	0	0
FG b	0	Fx	0	0	0	0
GF b	0	-Fb+Fx	0	0	0	0
GA 2b	0	2Fb-1/2qx ²	0	0	0	0
AG 2b	0	-2Fx+1/2qx ²	0	0	0	0
FB 2b	0	6Fb-3Fx	0	0	0	0
BF 2b	0	-3Fx	0	0	0	0
BE b	0	0	0	0	0	0
EB b	0	0	0	0	0	0
CD	elongazione asta N _{1CD} ε _{CD} L _{CD}				-Fb ² /EJ	
	totali				-8/3Fb ² /EJ	5/3Xb/EJ
	iperstatica X=W _{DE}				8/5Fb	

Sviluppi di calcolo iperstatica

$$L_{BC}^{xx} = \int_0^b (x^2/b^2) 1/EJ dx = [1/3 x^3/b^2]_0^b 1/EJ = (1/3 b) 1/EJ = 1/3 b/EJ$$

$$L_{CB}^{xx} = \int_0^b (1 - 2x/b + x^2/b^2) 1/EJ dx = [x - x^2/b + 1/3 x^3/b^2]_0^b 1/EJ = (b - b + 1/3 b) 1/EJ = 1/3 b/EJ$$

$$L_{CD}^{xx} = \int_0^b (1) 1/EJ dx = [x]_0^b 1/EJ = (b) 1/EJ = b/EJ$$

$$L_{DC}^{xx} = \int_0^b (1) 1/EJ dx = [x]_0^b 1/EJ = (b) 1/EJ = b/EJ$$

$$L_{DE}^{xx} = \int_0^b (1 - 2x/b + x^2/b^2) 1/EJ dx = [x - x^2/b + 1/3 x^3/b^2]_0^b 1/EJ = (b - b + 1/3 b) 1/EJ = 1/3 b/EJ$$

$$L_{ED}^{xx} = \int_0^b (x^2/b^2) 1/EJ dx = [1/3 x^3/b^2]_0^b 1/EJ = (1/3 b) 1/EJ = 1/3 b/EJ$$

$$L_{BC}^{xo} = \int_0^b (-1/2 x/b - x^2/b^2) Fb 1/EJ dx = [-1/4 x^2/b - 1/3 x^3/b^2]_0^b Fb 1/EJ = (-1/4 b - 1/3 b) Fb 1/EJ = -7/12 Fb²/EJ$$

$$L_{CB}^{xo} = \int_0^b (-3/2 + 5/2 x/b - x^2/b^2) Fb 1/EJ dx = [-3/2 x + 5/4 x^2/b - 1/3 x^3/b^2]_0^b Fb 1/EJ = (-3/2 b + 5/4 b - 1/3 b) Fb 1/EJ = -7/12 Fb²/EJ$$

$$L_{CD}^{xo} = \int_0^b (-5/2 + 5/2 x/b) Fb 1/EJ dx + 1 (-1) 1 Fb²/EJ = [-5/2 x + 5/4 x^2/b]_0^b Fb 1/EJ + 1 (-1) 1 Fb²/EJ = (-5/2 b + 5/4 b) Fb 1/EJ + 1 (-1) 1 Fb²/EJ = -9/4 Fb²/EJ$$

$$L_{DC}^{xo} = \int_0^b (-5/2 x/b) Fb 1/EJ dx + 1 (-1) 1 Fb²/EJ = [-5/4 x^2/b]_0^b Fb 1/EJ + 1 (-1) 1 Fb²/EJ = (-5/4 b) Fb 1/EJ + 1 (-1) 1 Fb²/EJ = -9/4 Fb²/EJ$$

$$L_{DE}^{xo} = \int_0^b (x/b - x^2/b^2) Fb 1/EJ dx = [1/2 x^2/b - 1/3 x^3/b^2]_0^b Fb 1/EJ = (1/2 b - 1/3 b) Fb 1/EJ = 1/6 Fb²/EJ$$

$$L_{ED}^{xo} = \int_0^b (x/b - x^2/b^2) Fb 1/EJ dx = [1/2 x^2/b - 1/3 x^3/b^2]_0^b Fb 1/EJ = (1/2 b - 1/3 b) Fb 1/EJ = 1/6 Fb²/EJ$$

- $H_{FB} = -F$
- $V_D = -F$
- $W_C = -W = -Fb$
- $W_G = -W = -Fb$
- $W_E = -W = -Fb$
- $p_{EF} = -q = -F/b$
- $q_{EF} = -q = -F/b$
- $q_{FG} = -q = -F/b$
- $\epsilon_{BE} = -\alpha T = -b^2 F/EJ$
- $k_C = 4EJ/b^3$
- $EJ_{AB} = EJ$
- $EJ_{BC} = EJ$
- $EJ_{CD} = EJ$
- $EJ_{DE} = EJ$
- $EJ_{EF} = EJ$
- $EJ_{FG} = EJ$
- $EJ_{GA} = EJ$
- $EJ_{FB} = EJ$
- $EJ_{BE} = EJ$

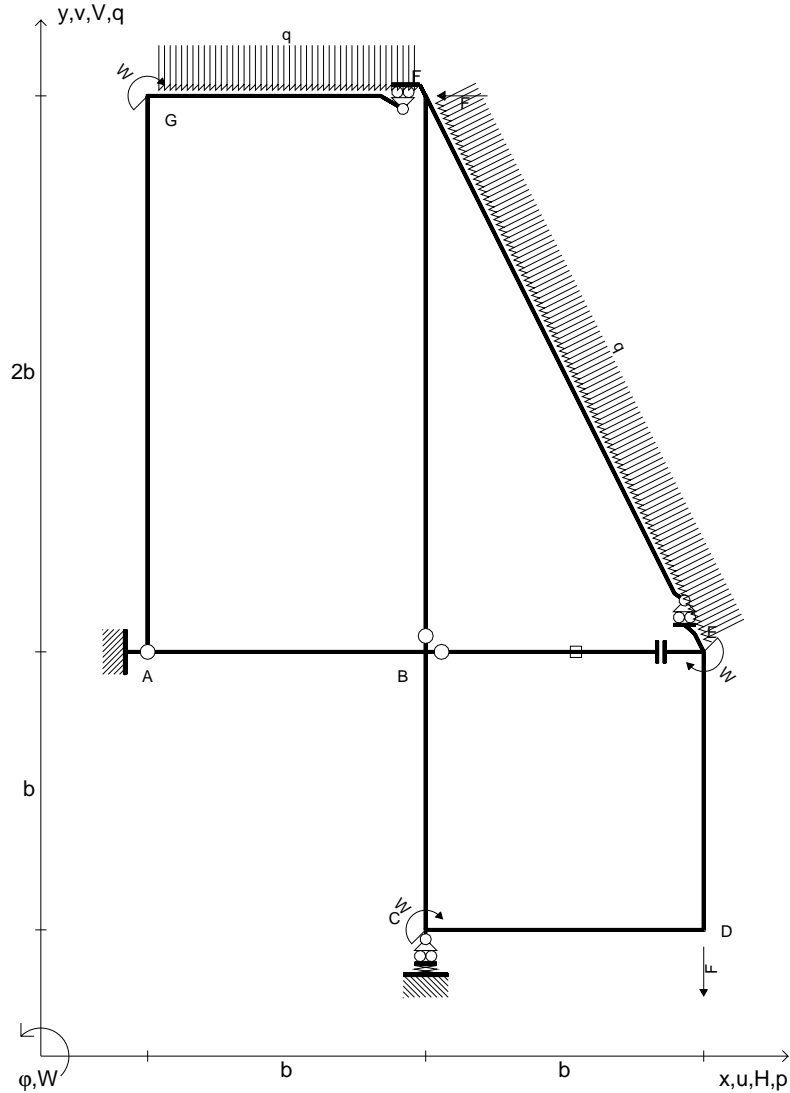

Reazioni iperstatiche in soluzione: $X=W_{DE}$
 Carichi e deformazioni date hanno verso efficace in disegno.
 Calcolare reazioni vincolari della struttura e delle aste.
 Tracciare i diagrammi quotati delle azioni interne nelle aste.
 Diagrammi di carico con valori riferiti ad asse della trave.
 Componenti di carico distribuito riferiti ad assi ortogonali.
 $J_{YZ} - x_{YZ} - \theta_{YZ}$ riferimento locale asta YZ con origine in Y.
 Elongazione termica specifica ϵ assegnata su asta BE.
 @ Adolfo Zavelani Rossi, Politecnico di Milano, vers.27.03.13

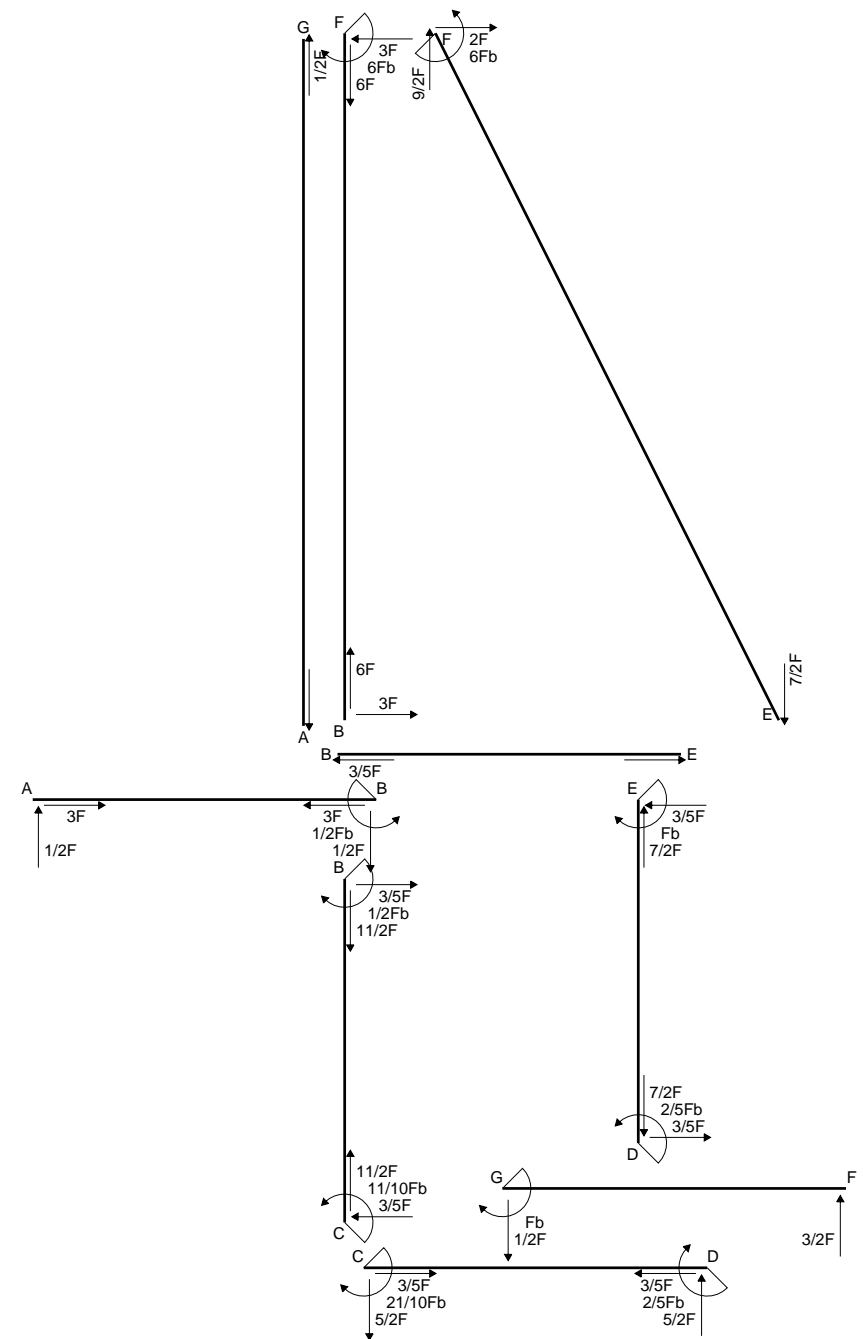

Quadro contributi PLV per iperstatica $X=W_{DE}$

→	$M_x(x)$	$M_o(x)$	$M_x M_o$	$M_x M_x$	$\int M_x M_o / EJ dx$	$\int X M_x M_x / EJ dx$
AB b	0	1/2Fx	0	0	0	0
BA b	0	-1/2Fb+1/2Fx	0	0	0	0
BC b	-x/b	1/2Fb+Fx	-1/2Fx-Fx ² /b	x ² /b ²	-7/12Fb ² /EJ	1/3Xb/EJ
CB b	1-x/b	-3/2Fb+Fx	-3/2Fb+5/2Fx-Fx ² /b	1-2x/b+x ² /b ²	-5/4Fb ² /EJ	Xb/EJ
CD b	-1	5/2Fb-5/2Fx	-5/2Fb+5/2Fx	1	-5/4Fb ² /EJ	Xb/EJ
DC b	1	-5/2Fx	-5/2Fx	1	-5/4Fb ² /EJ	Xb/EJ
DE b	-1+x/b	-Fx	Fx-Fx ² /b	1-2x/b+x ² /b ²	1/6Fb ² /EJ	1/3Xb/EJ
ED b	x/b	Fb-Fx	Fx-Fx ² /b	x ² /b ²	1/6Fb ² /EJ	1/3Xb/EJ
EF √5b	0	7√5/10Fx+1/2qx ²	0	0	0	0
FG b	0	-3/2Fx+1/2qx ²	0	0	0	0
GF b	0	Fb-1/2Fx-1/2qx ²	0	0	0	0
GA 2b	0	0	0	0	0	0
AG 2b	0	0	0	0	0	0
FB 2b	0	6Fb-3Fx	0	0	0	0
BF 2b	0	-3Fx	0	0	0	0
BE b	0	0	0	0	0	0
EB b	0	0	0	0	0	0
BE	elongazione asta $N_{1BE} \epsilon_{BE} L_{BE}$				Fb ² /EJ	
	totali				-2/3Fb ² /EJ	5/3Xb/EJ
	iperstatica $X=W_{DE}$				2/5Fb	

Sviluppi di calcolo iperstatica

$$L_{BC}^{xx} = \int_0^b (x^2/b^2) 1/EJ dx = [1/3 x^3/b^2]_0^b 1/EJ = (1/3 b) 1/EJ = 1/3 b/EJ$$

$$L_{CB}^{xx} = \int_0^b (1 - 2x/b + x^2/b^2) 1/EJ dx = [x - x^2/b + 1/3 x^3/b^2]_0^b 1/EJ = (b - b + 1/3 b) 1/EJ = 1/3 b/EJ$$

$$L_{CD}^{xx} = \int_0^b (1) 1/EJ dx = [x]_0^b 1/EJ = (b) 1/EJ = b/EJ$$

$$L_{DC}^{xx} = \int_0^b (1) 1/EJ dx = [x]_0^b 1/EJ = (b) 1/EJ = b/EJ$$

$$L_{DE}^{xx} = \int_0^b (1 - 2x/b + x^2/b^2) 1/EJ dx = [x - x^2/b + 1/3 x^3/b^2]_0^b 1/EJ = (b - b + 1/3 b) 1/EJ = 1/3 b/EJ$$

$$L_{ED}^{xx} = \int_0^b (x^2/b^2) 1/EJ dx = [1/3 x^3/b^2]_0^b 1/EJ = (1/3 b) 1/EJ = 1/3 b/EJ$$

$$L_{BC}^{xo} = \int_0^b (-1/2 x/b - x^2/b^2) Fb 1/EJ dx = [-1/4 x^2/b - 1/3 x^3/b^2]_0^b Fb 1/EJ = (-1/4 b - 1/3 b) Fb 1/EJ = -7/12 Fb^2/EJ$$

$$L_{CB}^{xo} = \int_0^b (-3/2 + 5/2 x/b - x^2/b^2) Fb 1/EJ dx = [-3/2 x + 5/4 x^2/b - 1/3 x^3/b^2]_0^b Fb 1/EJ = (-3/2 b + 5/4 b - 1/3 b) Fb 1/EJ = -7/12 Fb^2/EJ$$

$$L_{CD}^{xo} = \int_0^b (-5/2 + 5/2 x/b) Fb 1/EJ dx = [-5/2 x + 5/4 x^2/b]_0^b Fb 1/EJ = (-5/2 b + 5/4 b) Fb 1/EJ = -5/4 Fb^2/EJ$$

$$L_{DC}^{xo} = \int_0^b (-5/2 x/b) Fb 1/EJ dx = [-5/4 x^2/b]_0^b Fb 1/EJ = (-5/4 b) Fb 1/EJ = -5/4 Fb^2/EJ$$

$$L_{DE}^{xo} = \int_0^b (x/b - x^2/b^2) Fb 1/EJ dx = [1/2 x^2/b - 1/3 x^3/b^2]_0^b Fb 1/EJ = (1/2 b - 1/3 b) Fb 1/EJ = 1/6 Fb^2/EJ$$

$$L_{ED}^{xo} = \int_0^b (x/b - x^2/b^2) Fb 1/EJ dx = [1/2 x^2/b - 1/3 x^3/b^2]_0^b Fb 1/EJ = (1/2 b - 1/3 b) Fb 1/EJ = 1/6 Fb^2/EJ$$

- $H_{FB} = -F$
- $V_D = -F$
- $W_C = -W = -Fb$
- $W_G = -W = -Fb$
- $W_E = -W = -Fb$
- $p_{EF} = -q = -F/b$
- $q_{EF} = -q = -F/b$
- $q_{FG} = -q = -F/b$
- $\epsilon_{CD} = -\alpha T = -b^2 F/EJ$
- $k_C = 4EJ/b^3$
- $EJ_{AB} = EJ$
- $EJ_{BC} = EJ$
- $EJ_{CD} = EJ$
- $EJ_{DE} = EJ$
- $EJ_{EF} = EJ$
- $EJ_{FG} = EJ$
- $EJ_{GA} = EJ$
- $EJ_{FB} = EJ$
- $EJ_{BE} = EJ$

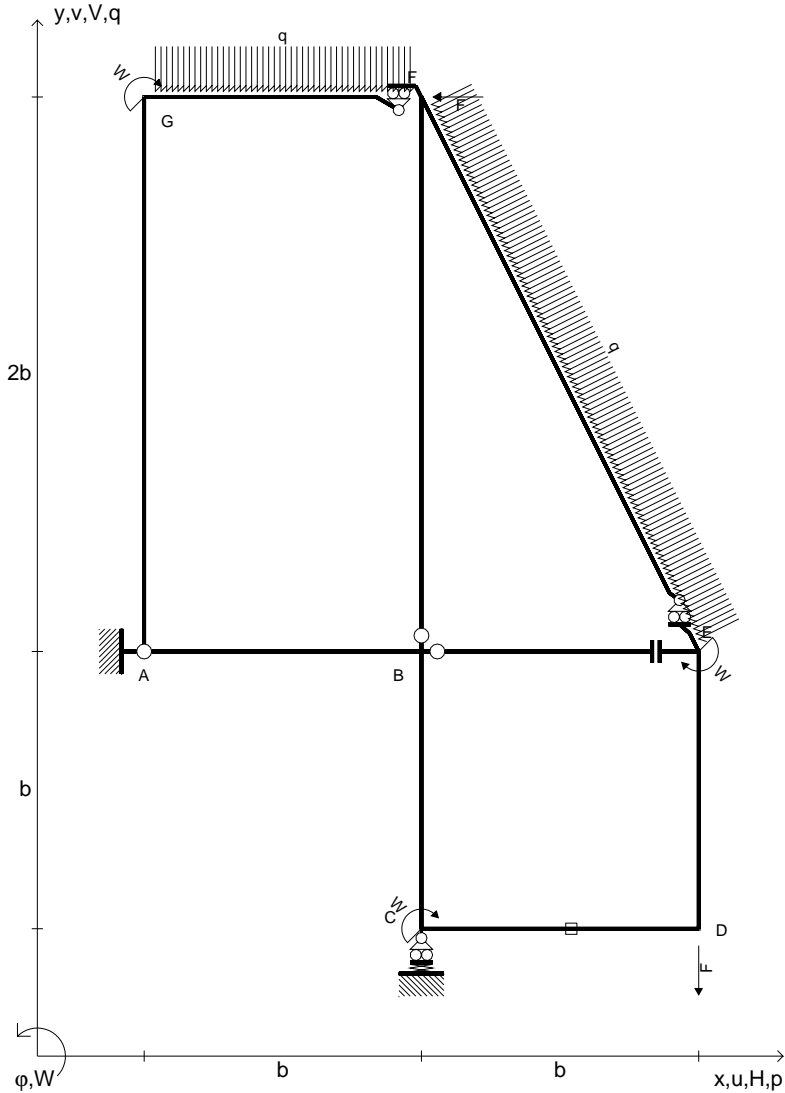

Reazioni iperstatiche in soluzione: $X=W_{DE}$
 Carichi e deformazioni date hanno verso efficace in disegno.
 Calcolare reazioni vincolari della struttura e delle aste.
 Tracciare i diagrammi quotati delle azioni interne nelle aste.
 Diagrammi di carico con valori riferiti ad asse della trave.
 Componenti di carico distribuito riferiti ad assi ortogonali.
 $J_{YZ} - x_{YZ} - \theta_{YZ}$ riferimento locale asta YZ con origine in Y.
 Elongazione termica specifica ϵ assegnata su asta CD.
 @ Adolfo Zavelani Rossi, Politecnico di Milano, vers.27.03.13

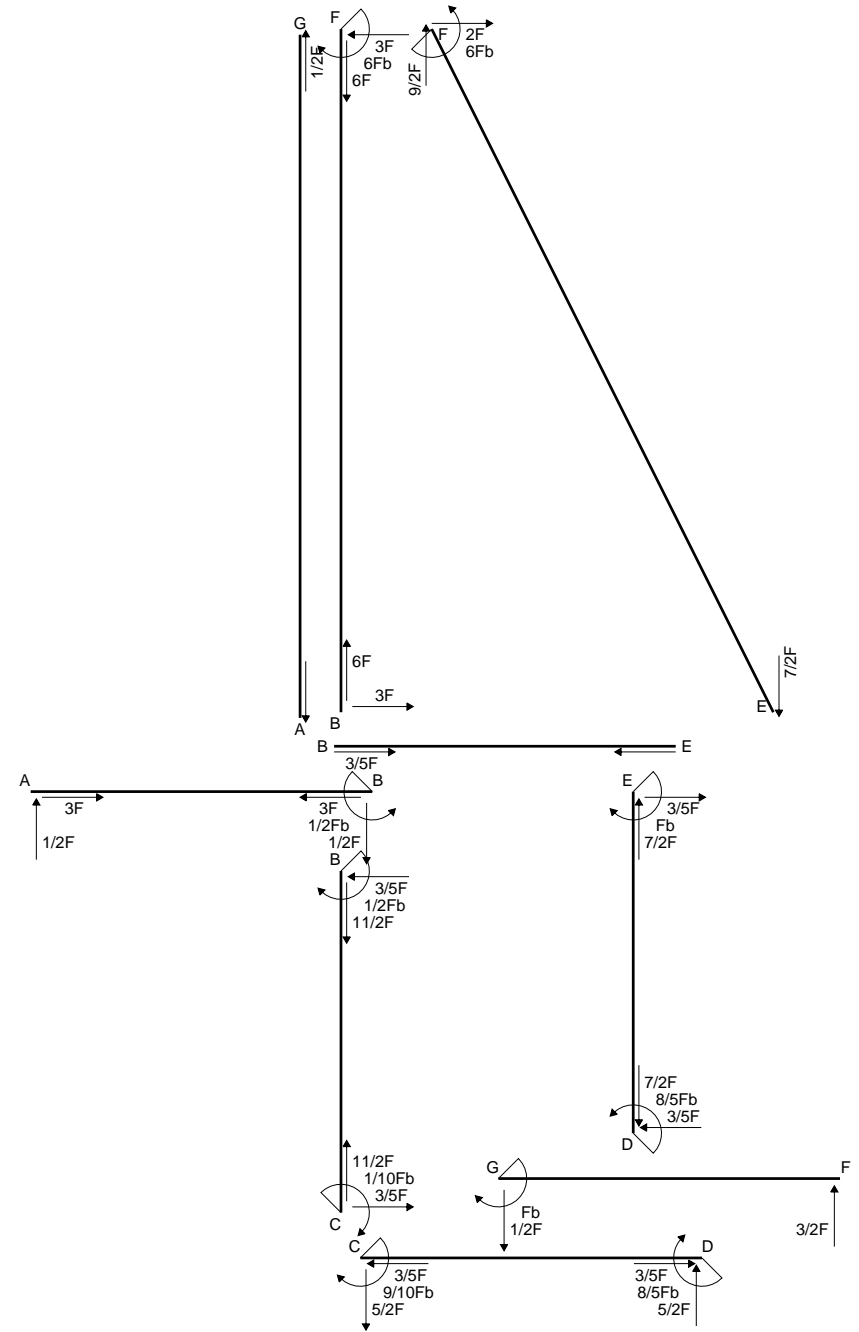

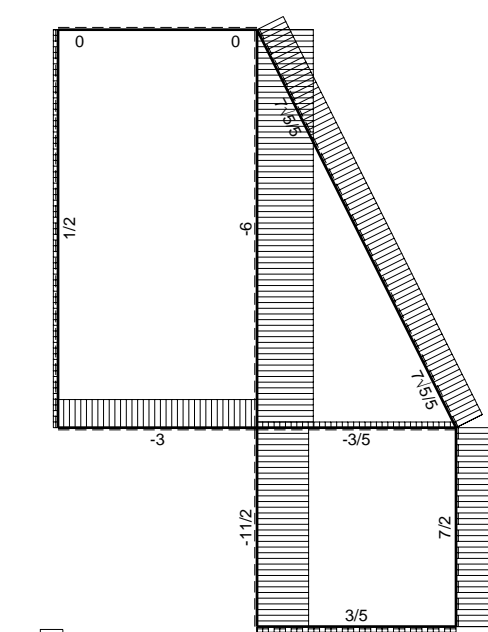

← (+) → F

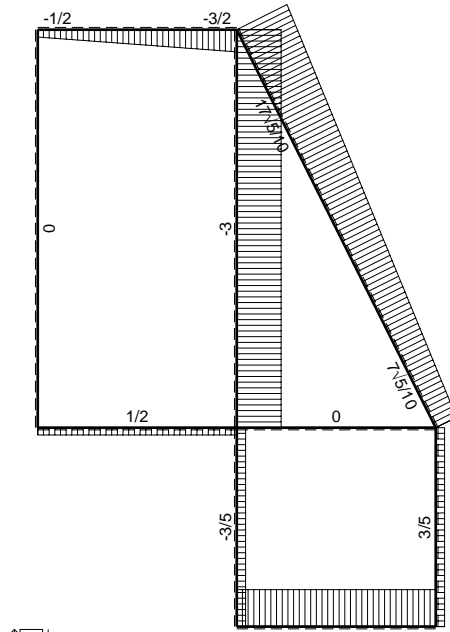

↑ (+) ↓ F

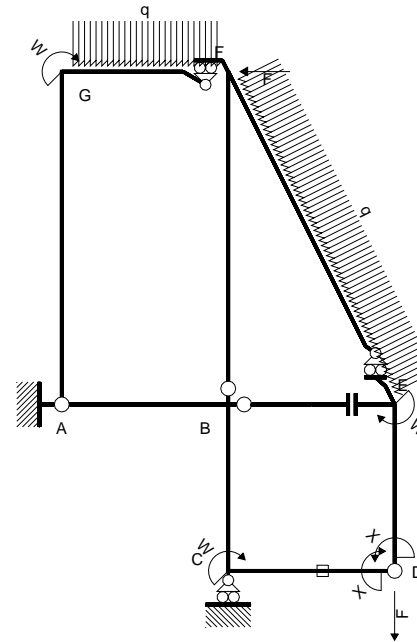

Schema di calcolo iperstatico

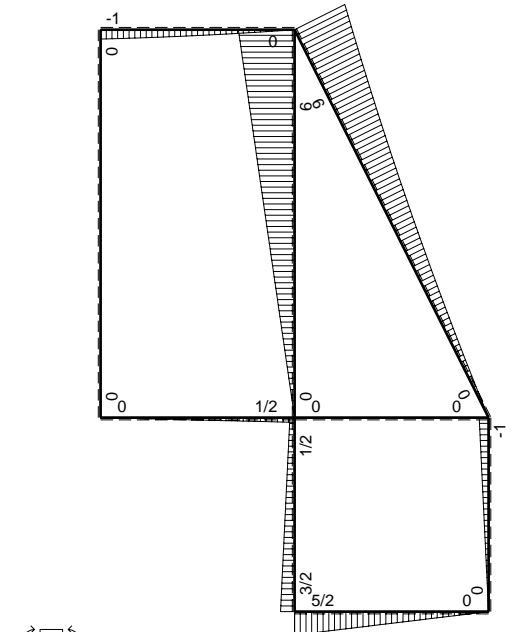

⌚ (+) ⌚ M₀ flessione da carichi assegnati

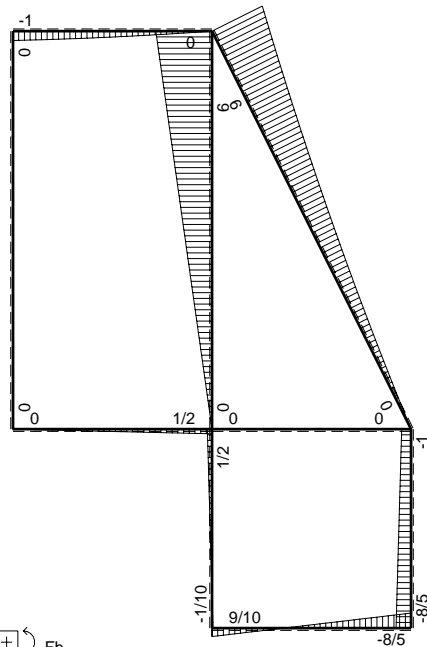

⌚ (+) ⌚ F_b

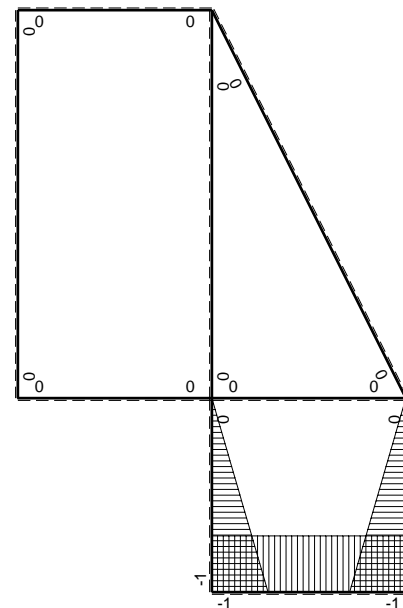

⌚ (+) ⌚ M_x flessione da iperstatica X=1

Quadro contributi PLV per iperstatica $X=W_{DE}$

→	$M_x(x)$	$M_o(x)$	$M_x M_o$	$M_x M_x$	$\int M_x M_o / EJ dx$	$\int X M_x M_x / EJ dx$
AB b	0	1/2Fx	0	0	0	0
BA b	0	-1/2Fb+1/2Fx	0	0	0	0
BC b	-x/b	1/2Fb+Fx	-1/2Fx-Fx ² /b	x ² /b ²	-7/12Fb ² /EJ	1/3Xb/EJ
CB b	1-x/b	-3/2Fb+Fx	-3/2Fb+5/2Fx-Fx ² /b	1-2x/b+x ² /b ²		
CD b	-1	5/2Fb-5/2Fx	-5/2Fb+5/2Fx	1	-5/4Fb ² /EJ	Xb/EJ
DC b	1	-5/2Fx	-5/2Fx	1		
DE b	-1+x/b	-Fx	Fx-Fx ² /b	1-2x/b+x ² /b ²	1/6Fb ² /EJ	1/3Xb/EJ
ED b	x/b	Fb-Fx	Fx-Fx ² /b	x ² /b ²		
EF √5b	0	7√5/10Fx+1/2qx ²	0	0	0	0
FG b	0	-3/2Fx+1/2qx ²	0	0	0	0
GF b	0	Fb-1/2Fx-1/2qx ²	0	0	0	0
GA 2b	0	0	0	0	0	0
AG 2b	0	0	0	0	0	0
FB 2b	0	6Fb-3Fx	0	0	0	0
BF 2b	0	-3Fx	0	0	0	0
BE b	0	0	0	0	0	0
EB b	0	0	0	0	0	0
CD	elongazione asta $N_{1CD} \epsilon_{CD} L_{CD}$				-Fb ² /EJ	
	totali				-8/3Fb ² /EJ	5/3Xb/EJ
	iperstatica $X=W_{DE}$				8/5Fb	

Sviluppi di calcolo iperstatica

$$L_{BC}^{xx} = \int_0^b (x^2/b^2) 1/EJ dx = [1/3 x^3/b^2]_0^b 1/EJ = (1/3 b) 1/EJ = 1/3 b/EJ$$

$$L_{CB}^{xx} = \int_0^b (1 - 2x/b + x^2/b^2) 1/EJ dx = [x - x^2/b + 1/3 x^3/b^2]_0^b 1/EJ = (b - b + 1/3 b) 1/EJ = 1/3 b/EJ$$

$$L_{CD}^{xx} = \int_0^b (1) 1/EJ dx = [x]_0^b 1/EJ = (b) 1/EJ = b/EJ$$

$$L_{DC}^{xx} = \int_0^b (1) 1/EJ dx = [x]_0^b 1/EJ = (b) 1/EJ = b/EJ$$

$$L_{DE}^{xx} = \int_0^b (1 - 2x/b + x^2/b^2) 1/EJ dx = [x - x^2/b + 1/3 x^3/b^2]_0^b 1/EJ = (b - b + 1/3 b) 1/EJ = 1/3 b/EJ$$

$$L_{ED}^{xx} = \int_0^b (x^2/b^2) 1/EJ dx = [1/3 x^3/b^2]_0^b 1/EJ = (1/3 b) 1/EJ = 1/3 b/EJ$$

$$L_{BC}^{xo} = \int_0^b (-1/2 x/b - x^2/b^2) Fb 1/EJ dx = [-1/4 x^2/b - 1/3 x^3/b^2]_0^b Fb 1/EJ = (-1/4 b - 1/3 b) Fb 1/EJ = -7/12 Fb^2/EJ$$

$$L_{CB}^{xo} = \int_0^b (-3/2 + 5/2 x/b - x^2/b^2) Fb 1/EJ dx = [-3/2 x + 5/4 x^2/b - 1/3 x^3/b^2]_0^b Fb 1/EJ = (-3/2 b + 5/4 b - 1/3 b) Fb 1/EJ = -7/12 Fb^2/EJ$$

$$L_{CD}^{xo} = \int_0^b (-5/2 + 5/2 x/b) Fb 1/EJ dx + 1 (-1) 1 Fb^2/EJ = [-5/2 x + 5/4 x^2/b]_0^b Fb 1/EJ + 1 (-1) 1 Fb^2/EJ = (-5/2 b + 5/4 b) Fb 1/EJ + 1 (-1) 1 Fb^2/EJ = -9/4 Fb^2/EJ$$

$$L_{DC}^{xo} = \int_0^b (-5/2 x/b) Fb 1/EJ dx + 1 (-1) 1 Fb^2/EJ = [-5/4 x^2/b]_0^b Fb 1/EJ + 1 (-1) 1 Fb^2/EJ = (-5/4 b) Fb 1/EJ + 1 (-1) 1 Fb^2/EJ = -9/4 Fb^2/EJ$$

$$L_{DE}^{xo} = \int_0^b (x/b - x^2/b^2) Fb 1/EJ dx = [1/2 x^2/b - 1/3 x^3/b^2]_0^b Fb 1/EJ = (1/2 b - 1/3 b) Fb 1/EJ = 1/6 Fb^2/EJ$$

$$L_{ED}^{xo} = \int_0^b (x/b - x^2/b^2) Fb 1/EJ dx = [1/2 x^2/b - 1/3 x^3/b^2]_0^b Fb 1/EJ = (1/2 b - 1/3 b) Fb 1/EJ = 1/6 Fb^2/EJ$$

- $H_{FB} = -F$
- $V_D = -F$
- $W_C = -W = -Fb$
- $W_G = -W = -Fb$
- $W_E = -W = -Fb$
- $q_{CD} = -q = -F/b$
- $p_{FB} = -q = -F/b$
- $\epsilon_{CD} = -\alpha T = -b^2 F/EJ$
- $k_C = 4EJ/b^3$
- $EJ_{AB} = EJ$
- $EJ_{BC} = EJ$
- $EJ_{CD} = EJ$
- $EJ_{DE} = EJ$
- $EJ_{EF} = EJ$
- $EJ_{FG} = EJ$
- $EJ_{GA} = EJ$
- $EJ_{FB} = EJ$
- $EJ_{BE} = EJ$

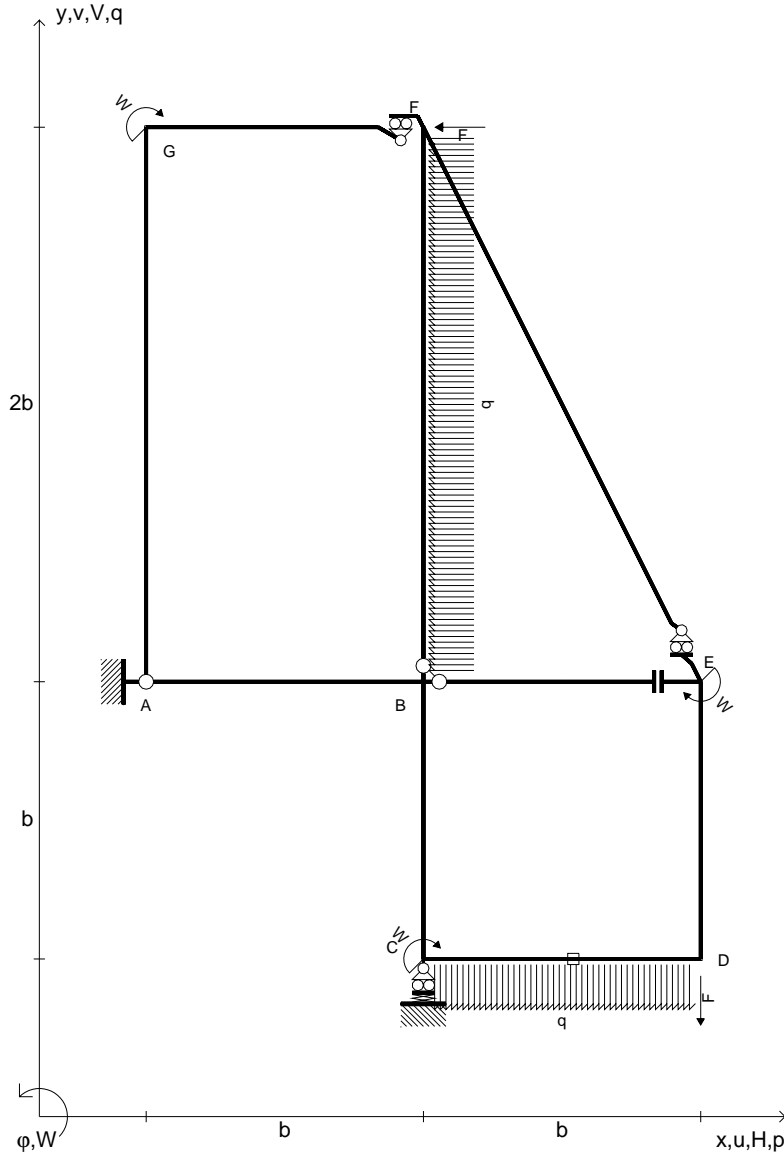

Reazioni iperstatiche in soluzione: $X=W_{DE}$
 Carichi e deformazioni date hanno verso efficace in disegno.
 Calcolare reazioni vincolari della struttura e delle aste.
 Tracciare i diagrammi quotati delle azioni interne nelle aste.
 $J_{YZ} - x_{YZ} - \theta_{YZ}$ riferimento locale asta YZ con origine in Y.
 Elongazione termica specifica ϵ assegnata su asta CD.
 © Adolfo Zavelani Rossi, Politecnico di Milano, vers.27.03.13

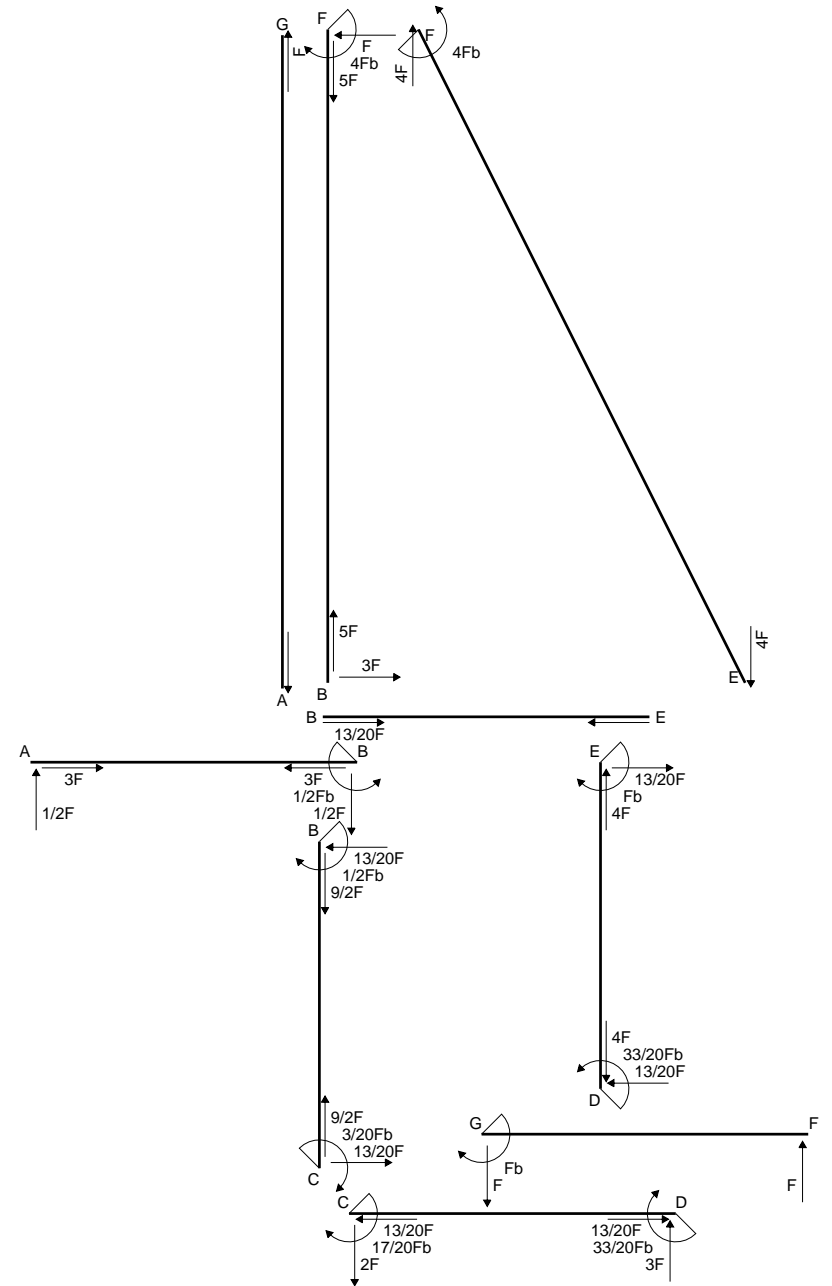

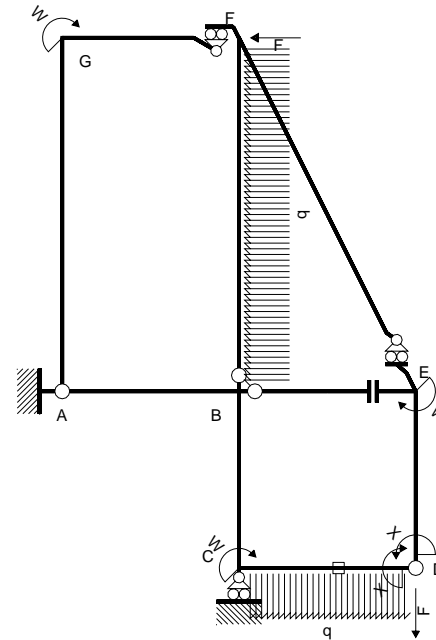
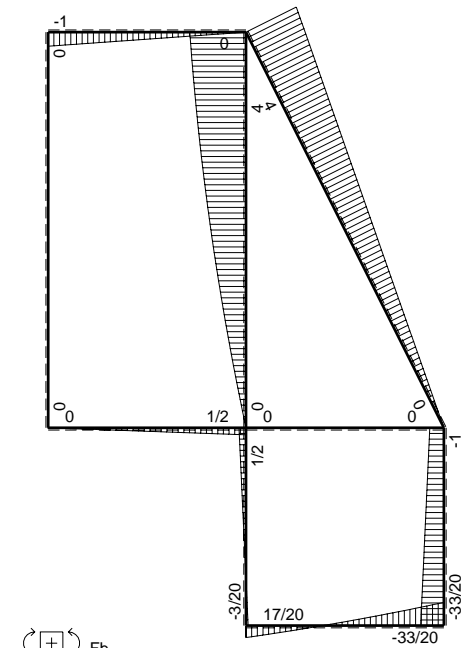
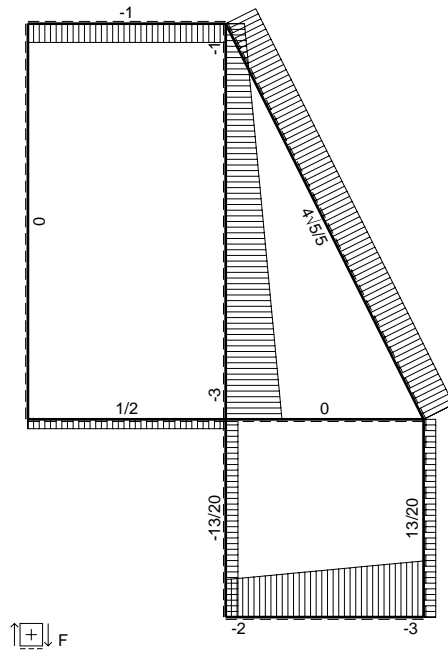
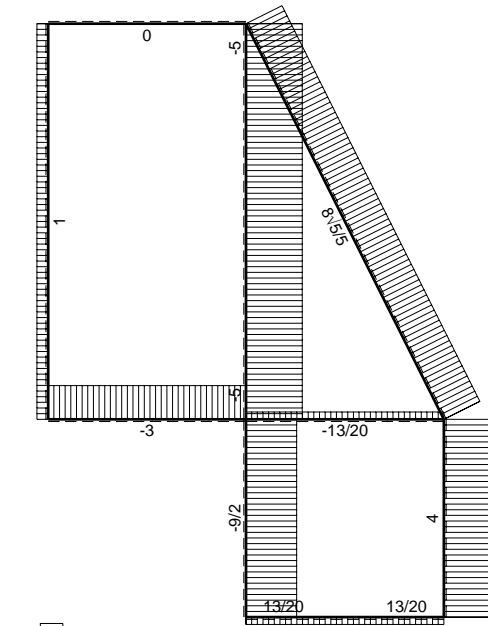

Schema di calcolo iperstatico

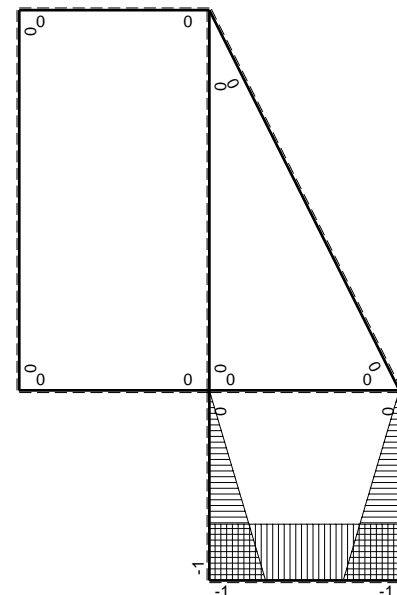
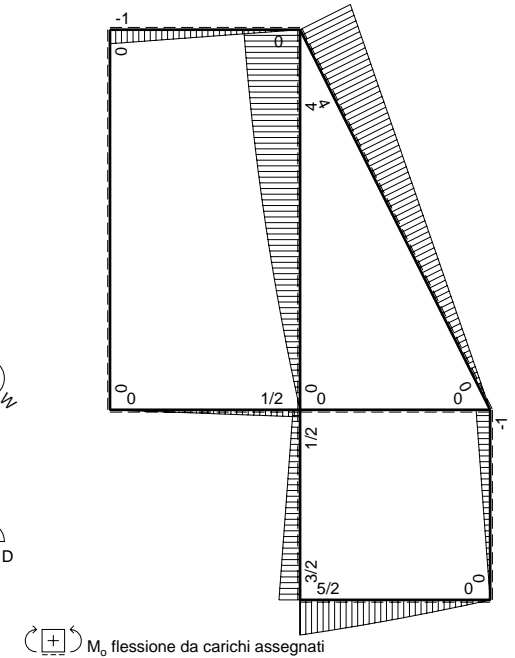

M_x flessione da iperstatica X=1

Quadro contributi PLV per iperstatica X=W_{DE}

→	M _x (x)	M _o (x)	M _x M _o	M _x M _x	$\int M_x M_o / EJ dx$	$\int X M_x M_x / EJ dx$
AB b	0	1/2Fx	0	0	0	0
BA b	0	-1/2Fb+1/2Fx	0	0	0	0
BC b	-x/b	1/2Fb+Fx	-1/2Fx-Fx ² /b	x ² /b ²	-7/12Fb ² /EJ	1/3Xb/EJ
CB b	1-x/b	-3/2Fb+Fx	-3/2Fb+5/2Fx-Fx ² /b	1-2x/b+x ² /b ²	-4/3Fb ² /EJ	Xb/EJ
CD b	-1	5/2Fb-2Fx-1/2qx ²	-5/2Fb+2Fx+1/2Fx ² /b	1	-4/3Fb ² /EJ	Xb/EJ
DC b	1	-3Fx+1/2qx ²	-3Fx+1/2Fx ² /b	1	-4/3Fb ² /EJ	Xb/EJ
DE b	-1+x/b	-Fx	Fx-Fx ² /b	1-2x/b+x ² /b ²	1/6Fb ² /EJ	1/3Xb/EJ
ED b	x/b	Fb-Fx	Fx-Fx ² /b	x ² /b ²	1/6Fb ² /EJ	1/3Xb/EJ
EF √5b	0	4√5/5Fx	0	0	0	0
FG b	0	-Fx	0	0	0	0
GF b	0	Fb-Fx	0	0	0	0
GA 2b	0	0	0	0	0	0
AG 2b	0	0	0	0	0	0
FB 2b	0	4Fb-Fx-1/2qx ²	0	0	0	0
BF 2b	0	-3Fx+1/2qx ²	0	0	0	0
BE b	0	0	0	0	0	0
EB b	0	0	0	0	0	0
CD	elongazione asta N _{1CD} ε _{CD} L _{CD}				-Fb ² /EJ	
	totali				-11/4Fb ² /EJ	5/3Xb/EJ
	iperstatica X=W _{DE}				33/20Fb	

Sviluppi di calcolo iperstatica

$$L_{BC}^{xx} = \int_0^b (x^2/b^2) 1/EJ dx = [1/3 x^3/b^2]_0^b 1/EJ = (1/3 b) 1/EJ = 1/3 b/EJ$$

$$L_{CB}^{xx} = \int_0^b (1 - 2x/b + x^2/b^2) 1/EJ dx = [x - x^2/b + 1/3 x^3/b^2]_0^b 1/EJ = (b - b + 1/3 b) 1/EJ = 1/3 b/EJ$$

$$L_{CD}^{xx} = \int_0^b (1) 1/EJ dx = [x]_0^b 1/EJ = (b) 1/EJ = b/EJ$$

$$L_{DC}^{xx} = \int_0^b (1) 1/EJ dx = [x]_0^b 1/EJ = (b) 1/EJ = b/EJ$$

$$L_{DE}^{xx} = \int_0^b (1 - 2x/b + x^2/b^2) 1/EJ dx = [x - x^2/b + 1/3 x^3/b^2]_0^b 1/EJ = (b - b + 1/3 b) 1/EJ = 1/3 b/EJ$$

$$L_{ED}^{xx} = \int_0^b (x^2/b^2) 1/EJ dx = [1/3 x^3/b^2]_0^b 1/EJ = (1/3 b) 1/EJ = 1/3 b/EJ$$

$$L_{BC}^{xo} = \int_0^b (-1/2 x/b - x^2/b^2) Fb 1/EJ dx = [-1/4 x^2/b - 1/3 x^3/b^2]_0^b Fb 1/EJ = (-1/4 b - 1/3 b) Fb 1/EJ = -7/12 Fb²/EJ$$

$$L_{CB}^{xo} = \int_0^b (-3/2 + 5/2 x/b - x^2/b^2) Fb 1/EJ dx = [-3/2 x + 5/4 x^2/b - 1/3 x^3/b^2]_0^b Fb 1/EJ = (-3/2 b + 5/4 b - 1/3 b) Fb 1/EJ = -7/12 Fb²/EJ$$

$$L_{CD}^{xo} = \int_0^b (-5/2 + 2x/b + 1/2 x^2/b^2) Fb 1/EJ dx + 1 (-1) 1 Fb²/EJ = [-5/2 x + x^2/b + 1/6 x^3/b^2]_0^b Fb 1/EJ + 1 (-1) 1 Fb²/EJ = (-5/2 b + b + 1/6 b) Fb 1/EJ + 1 (-1) 1 Fb²/EJ = -7/3 Fb²/EJ$$

$$L_{DC}^{xo} = \int_0^b (-3x/b + 1/2 x^2/b^2) Fb 1/EJ dx + 1 (-1) 1 Fb²/EJ = [-3/2 x^2/b + 1/6 x^3/b^2]_0^b Fb 1/EJ + 1 (-1) 1 Fb²/EJ = (-3/2 b + 1/6 b) Fb 1/EJ + 1 (-1) 1 Fb²/EJ = -7/3 Fb²/EJ$$

$$L_{DE}^{xo} = \int_0^b (x/b - x^2/b^2) Fb 1/EJ dx = [1/2 x^2/b - 1/3 x^3/b^2]_0^b Fb 1/EJ = (1/2 b - 1/3 b) Fb 1/EJ = 1/6 Fb²/EJ$$

$$L_{ED}^{xo} = \int_0^b (x/b - x^2/b^2) Fb 1/EJ dx = [1/2 x^2/b - 1/3 x^3/b^2]_0^b Fb 1/EJ = (1/2 b - 1/3 b) Fb 1/EJ = 1/6 Fb²/EJ$$

$$L_{ED}^{xo} = \int_0^b (x/b - x^2/b^2) Fb 1/EJ dx = [1/2 x^2/b - 1/3 x^3/b^2]_0^b Fb 1/EJ = (1/2 b - 1/3 b) Fb 1/EJ = 1/6 Fb²/EJ$$

- $H_{FB} = -F$
- $V_D = -F$
- $W_C = -W = -Fb$
- $W_G = -W = -Fb$
- $W_E = -W = -Fb$
- $p_{FB} = -q = -F/b$
- $q_{BE} = -q = -F/b$
- $\epsilon_{BE} = -\alpha T = -b^2 F/EJ$
- $k_C = 4EJ/b^3$
- $EJ_{AB} = EJ$
- $EJ_{BC} = EJ$
- $EJ_{CD} = EJ$
- $EJ_{DE} = EJ$
- $EJ_{EF} = EJ$
- $EJ_{FG} = EJ$
- $EJ_{GA} = EJ$
- $EJ_{FB} = EJ$
- $EJ_{BE} = EJ$

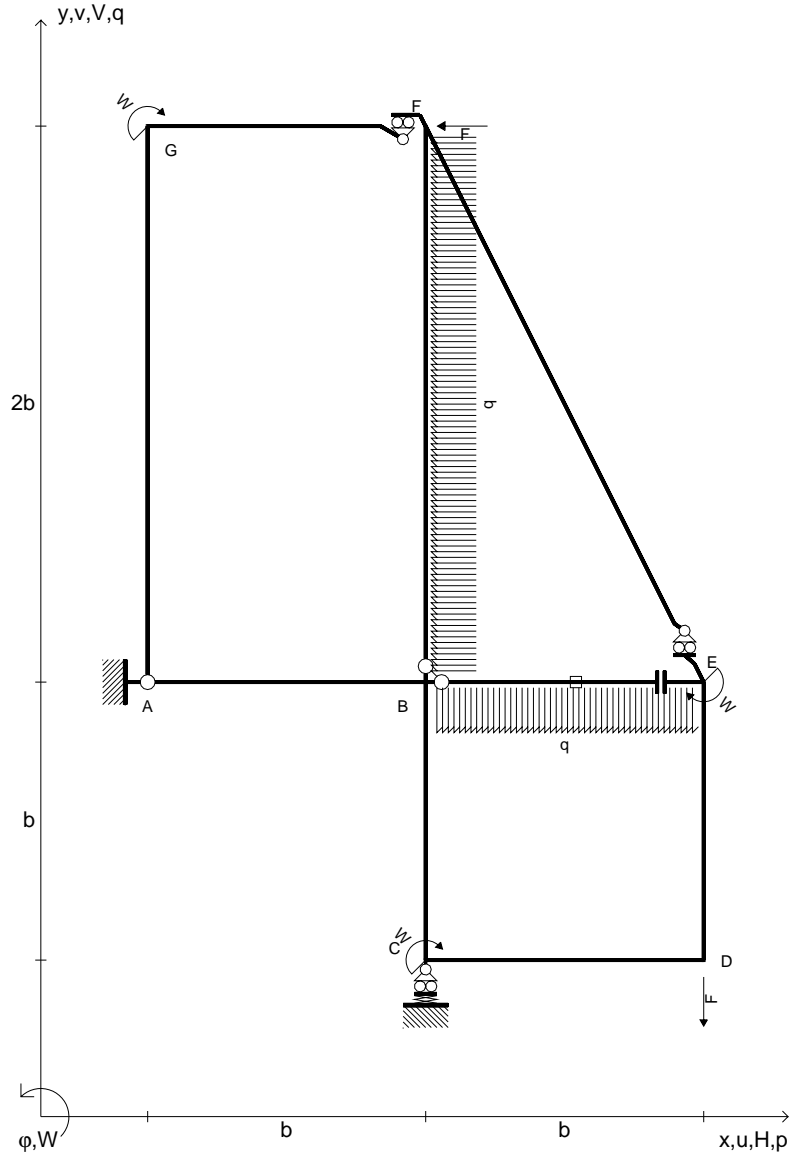

Reazioni iperstatiche in soluzione: $X=W_{DE}$
 Carichi e deformazioni date hanno verso efficace in disegno.
 Calcolare reazioni vincolari della struttura e delle aste.
 Tracciare i diagrammi quotati delle azioni interne nelle aste.
 $J_{YZ} - x_{YZ} - \theta_{YZ}$ riferimento locale asta YZ con origine in Y.
 Elongazione termica specifica ϵ assegnata su asta BE.
 © Adolfo Zavelani Rossi, Politecnico di Milano, vers.27.03.13

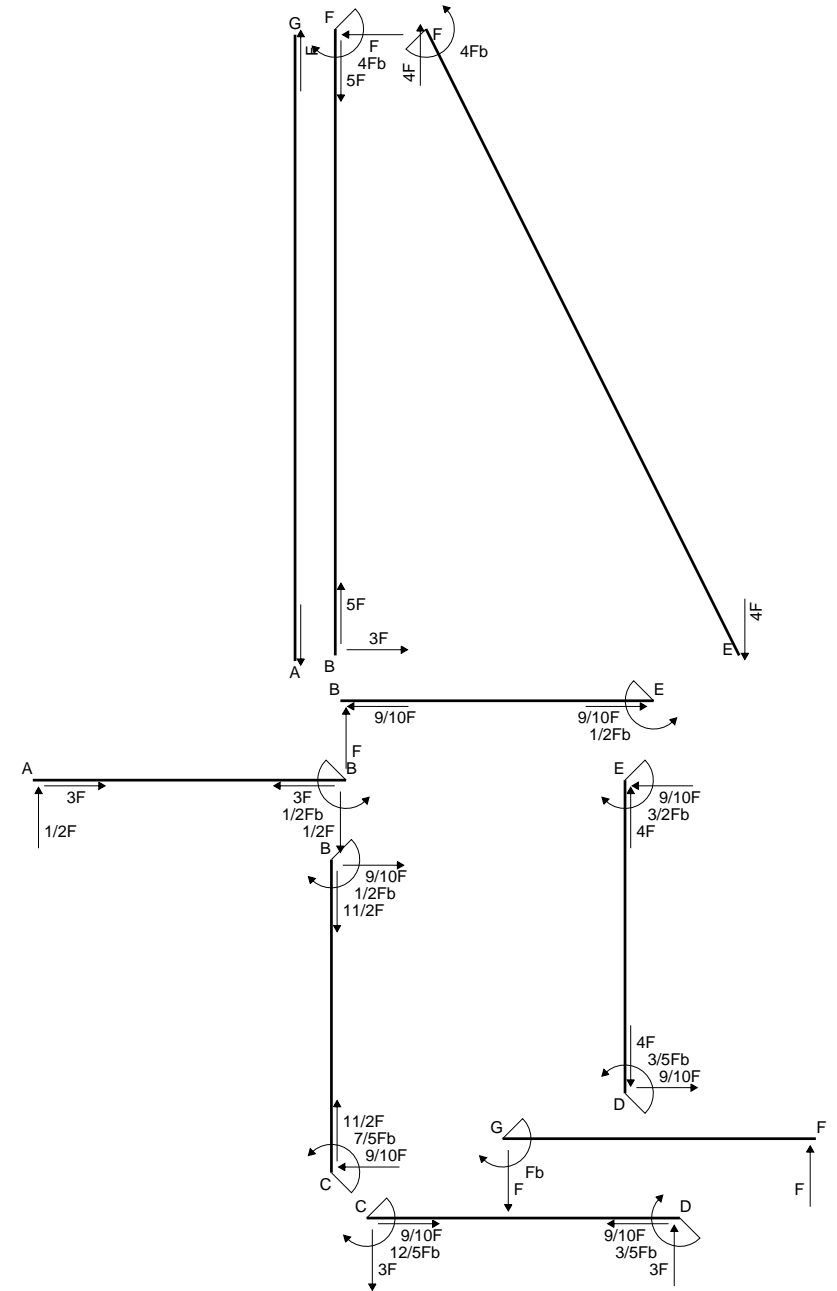

Quadro contributi PLV per iperstatica $X=W_{DE}$

→	$M_x(x)$	$M_o(x)$	$M_x M_o$	$M_x M_x$	$\int M_x M_o / EJ dx$	$\int X M_x M_x / EJ dx$
AB b	0	1/2Fx	0	0	0	0
BA b	0	-1/2Fb+1/2Fx	0	0	0	0
BC b	-x/b	1/2Fb+3/2Fx	-1/2Fx-3/2Fx ² /b	x ² /b ²	-3/4Fb ² /EJ	1/3Xb/EJ
CB b	1-x/b	-2Fb+3/2Fx	-2Fb+7/2Fx-3/2Fx ² /b	1-2x/b+x ² /b ²	-3/2Fb ² /EJ	Xb/EJ
CD b	-1	3Fb-3Fx	-3Fb+3Fx	1	-3/2Fb ² /EJ	Xb/EJ
DC b	1	-3Fx	-3Fx	1	-3/2Fb ² /EJ	Xb/EJ
DE b	-1+x/b	-3/2Fx	3/2Fx-3/2Fx ² /b	1-2x/b+x ² /b ²	1/4Fb ² /EJ	1/3Xb/EJ
ED b	x/b	3/2Fb-3/2Fx	3/2Fx-3/2Fx ² /b	x ² /b ²	1/4Fb ² /EJ	1/3Xb/EJ
EF √5b	0	4√5/5Fx	0	0	0	0
FG b	0	-Fx	0	0	0	0
GF b	0	Fb-Fx	0	0	0	0
GA 2b	0	0	0	0	0	0
AG 2b	0	0	0	0	0	0
FB 2b	0	4Fb-Fx-1/2qx ²	0	0	0	0
BF 2b	0	-3Fx+1/2qx ²	0	0	0	0
BE b	0	Fx-1/2qx ²	0	0	0	0
EB b	0	-1/2Fb+1/2qx ²	0	0	0	0
BE	elongazione asta $N_{1BE} \epsilon_{BE} L_{BE}$				Fb ² /EJ	
	totali				-Fb ² /EJ	5/3Xb/EJ
	iperstatica $X=W_{DE}$				3/5Fb	

Sviluppi di calcolo iperstatica

$$L_{BC}^{xx} = \int_0^b (x^2/b^2) 1/EJ dx = [1/3 x^3/b^2]_0^b 1/EJ = (1/3 b) 1/EJ = 1/3 b/EJ$$

$$L_{CB}^{xx} = \int_0^b (1 - 2x/b + x^2/b^2) 1/EJ dx = [x - x^2/b + 1/3 x^3/b^2]_0^b 1/EJ = (b - b + 1/3 b) 1/EJ = 1/3 b/EJ$$

$$L_{CD}^{xx} = \int_0^b (1) 1/EJ dx = [x]_0^b 1/EJ = (b) 1/EJ = b/EJ$$

$$L_{DC}^{xx} = \int_0^b (1) 1/EJ dx = [x]_0^b 1/EJ = (b) 1/EJ = b/EJ$$

$$L_{DE}^{xx} = \int_0^b (1 - 2x/b + x^2/b^2) 1/EJ dx = [x - x^2/b + 1/3 x^3/b^2]_0^b 1/EJ = (b - b + 1/3 b) 1/EJ = 1/3 b/EJ$$

$$L_{ED}^{xx} = \int_0^b (x^2/b^2) 1/EJ dx = [1/3 x^3/b^2]_0^b 1/EJ = (1/3 b) 1/EJ = 1/3 b/EJ$$

$$L_{BC}^{xo} = \int_0^b (-1/2 x/b - 3/2 x^2/b^2) Fb 1/EJ dx = [-1/4 x^2/b - 1/2 x^3/b^2]_0^b Fb 1/EJ = (-1/4 b - 1/2 b) Fb 1/EJ = -3/4 Fb^2/EJ$$

$$L_{CB}^{xo} = \int_0^b (-2 + 7/2 x/b - 3/2 x^2/b^2) Fb 1/EJ dx = [-2x + 7/4 x^2/b - 1/2 x^3/b^2]_0^b Fb 1/EJ = (-2b + 7/4 b - 1/2 b) Fb 1/EJ = -3/4 Fb^2/EJ$$

$$L_{CD}^{xo} = \int_0^b (-3 + 3x/b) Fb 1/EJ dx = [-3x + 3/2 x^2/b]_0^b Fb 1/EJ = (-3b + 3/2 b) Fb 1/EJ = -3/2 Fb^2/EJ$$

$$L_{DC}^{xo} = \int_0^b (-3x/b) Fb 1/EJ dx = [-3/2 x^2/b]_0^b Fb 1/EJ = (-3/2 b) Fb 1/EJ = -3/2 Fb^2/EJ$$

$$L_{DE}^{xo} = \int_0^b (3/2 x/b - 3/2 x^2/b^2) Fb 1/EJ dx = [3/4 x^2/b - 1/2 x^3/b^2]_0^b Fb 1/EJ = (3/4 b - 1/2 b) Fb 1/EJ = 1/4 Fb^2/EJ$$

$$L_{ED}^{xo} = \int_0^b (3/2 x/b - 3/2 x^2/b^2) Fb 1/EJ dx = [3/4 x^2/b - 1/2 x^3/b^2]_0^b Fb 1/EJ = (3/4 b - 1/2 b) Fb 1/EJ = 1/4 Fb^2/EJ$$

- $H_{FB} = -F$
- $V_D = -F$
- $W_C = -W = -Fb$
- $W_G = -W = -Fb$
- $W_E = -W = -Fb$
- $p_{FB} = -q = -F/b$
- $p_{DE} = -q = -F/b$
- $\epsilon_{BE} = -\alpha T = -b^2 F/EJ$
- $k_C = 4EJ/b^3$
- $EJ_{AB} = EJ$
- $EJ_{BC} = EJ$
- $EJ_{CD} = EJ$
- $EJ_{DE} = EJ$
- $EJ_{EF} = EJ$
- $EJ_{FG} = EJ$
- $EJ_{GA} = EJ$
- $EJ_{FB} = EJ$
- $EJ_{BE} = EJ$

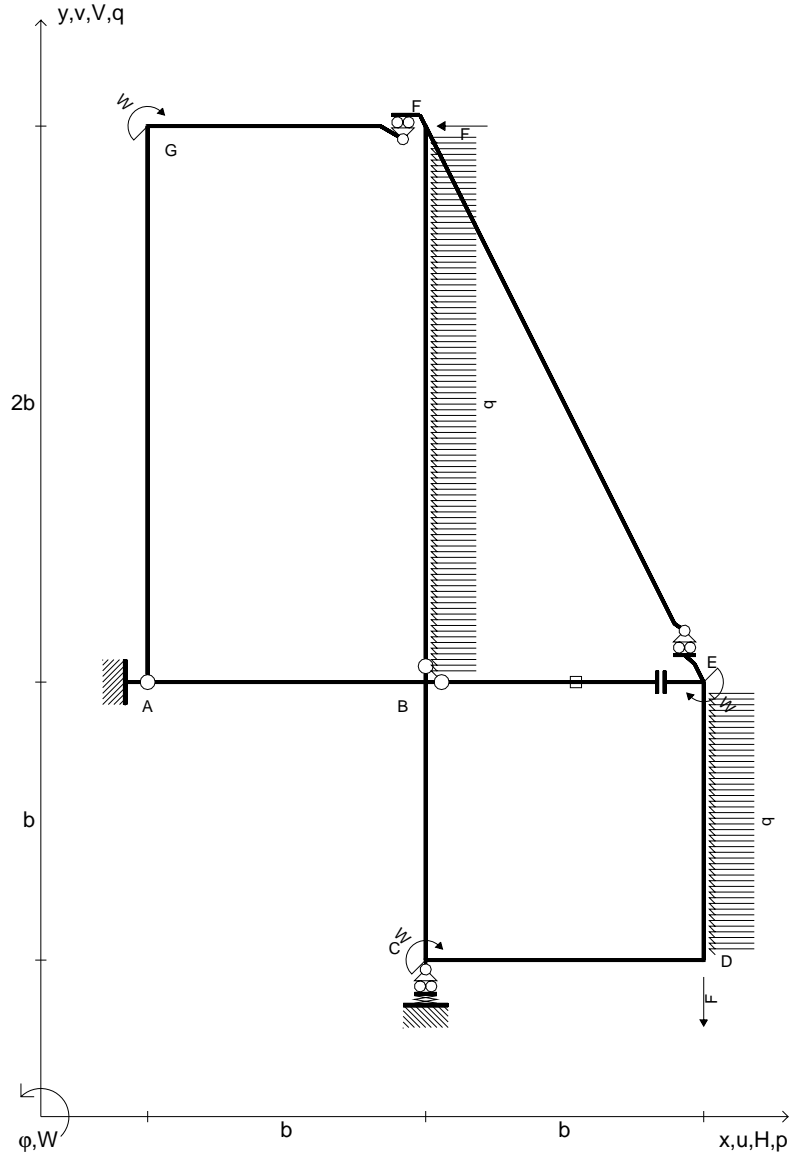

Reazioni iperstatiche in soluzione: $X=W_{DE}$
 Carichi e deformazioni date hanno verso efficace in disegno.
 Calcolare reazioni vincolari della struttura e delle aste.
 Tracciare i diagrammi quotati delle azioni interne nelle aste.
 $J_{YZ} - x_{YZ} - \theta_{YZ}$ riferimento locale asta YZ con origine in Y.
 Elongazione termica specifica ϵ assegnata su asta BE.
 @ Adolfo Zavelani Rossi, Politecnico di Milano, vers.27.03.13

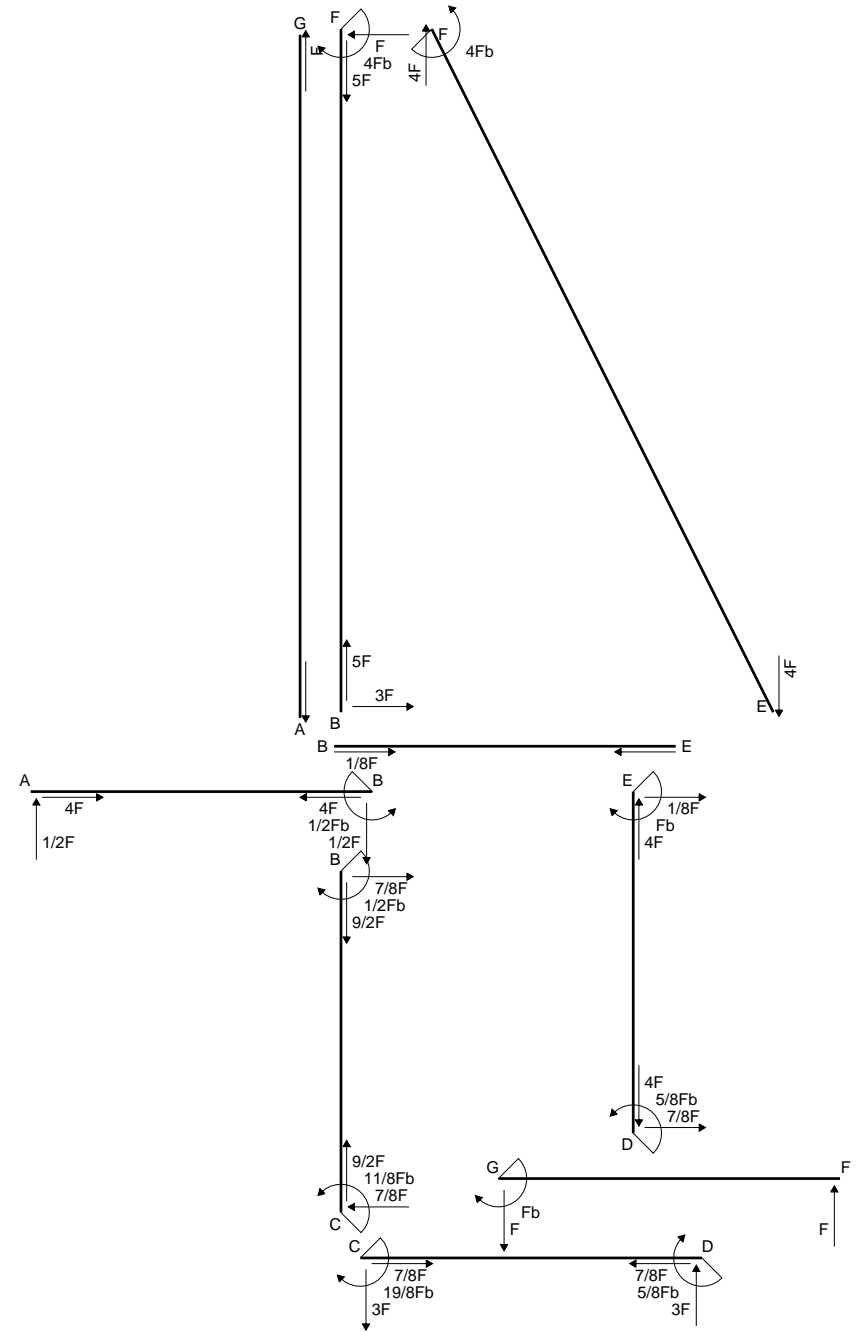

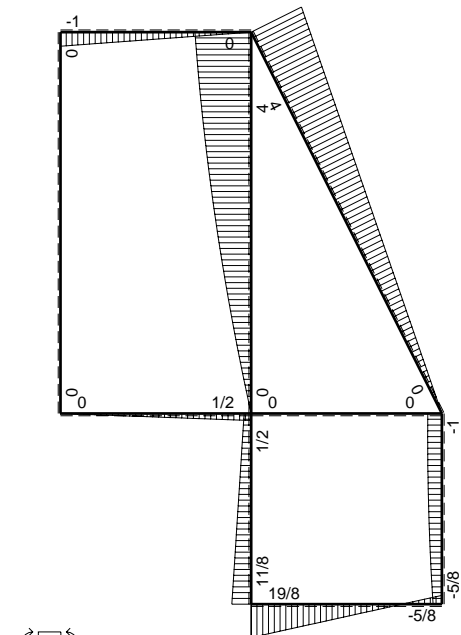
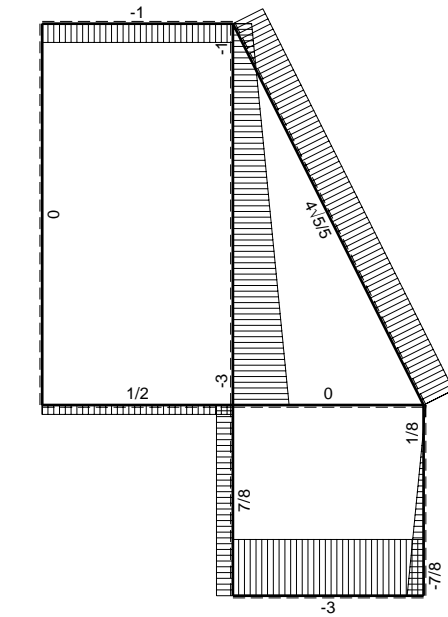
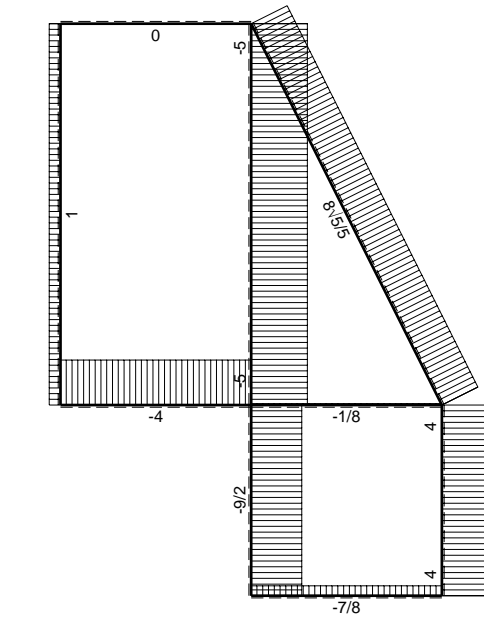

↑ (+) F

↺ (+) F_b

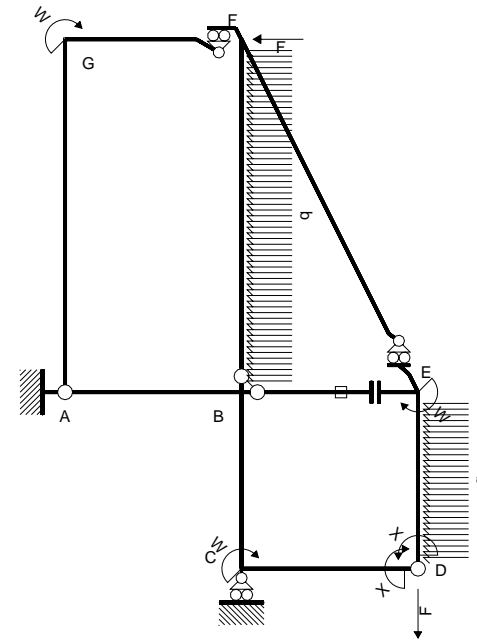

Schema di calcolo iperstatico

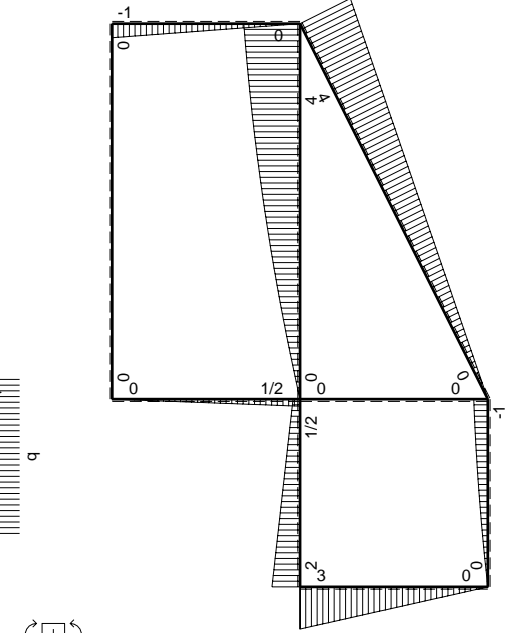

↺ (+) M₀ flessione da carichi assegnati

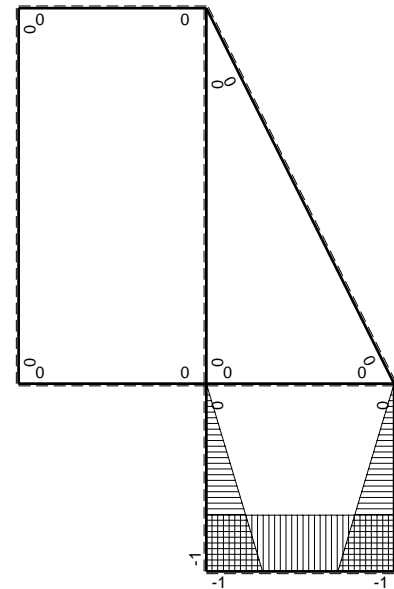

↺ (+) M_x flessione da iperstatica X=1

Quadro contributi PLV per iperstatica $X=W_{DE}$

→	$M_x(x)$	$M_o(x)$	$M_x M_o$	$M_x M_x$	$\int M_x M_o / EJ dx$	$\int X M_x M_x / EJ dx$
AB b	0	1/2Fx	0	0	0	0
BA b	0	-1/2Fb+1/2Fx	0	0	0	0
BC b	-x/b	1/2Fb+3/2Fx	-1/2Fx-3/2Fx ² /b	x ² /b ²	-3/4Fb ² /EJ	1/3Xb/EJ
CB b	1-x/b	-2Fb+3/2Fx	-2Fb+7/2Fx-3/2Fx ² /b	1-2x/b+x ² /b ²	-3/4Fb ² /EJ	1/3Xb/EJ
CD b	-1	3Fb-3Fx	-3Fb+3Fx	1	-3/2Fb ² /EJ	Xb/EJ
DC b	1	-3Fx	-3Fx	1	-3/2Fb ² /EJ	Xb/EJ
DE b	-1+x/b	-3/2Fx+1/2qx ²	3/2Fx-2Fx ² /b+1/2qx ³ /b	1-2x/b+x ² /b ²	5/24Fb ² /EJ	1/3Xb/EJ
ED b	x/b	Fb-1/2Fx-1/2qx ²	Fx-1/2Fx ² /b-1/2qx ³ /b	x ² /b ²	5/24Fb ² /EJ	1/3Xb/EJ
EF √5b	0	4√5/5Fx	0	0	0	0
FG b	0	-Fx	0	0	0	0
GF b	0	Fb-Fx	0	0	0	0
GA 2b	0	0	0	0	0	0
AG 2b	0	0	0	0	0	0
FB 2b	0	4Fb-Fx-1/2qx ²	0	0	0	0
BF 2b	0	-3Fx+1/2qx ²	0	0	0	0
BE b	0	0	0	0	0	0
EB b	0	0	0	0	0	0
BE	elongazione asta $N_{1BE} \epsilon_{BE} L_{BE}$				Fb ² /EJ	
	totali				-25/24Fb ² /EJ	5/3Xb/EJ
	iperstatica $X=W_{DE}$				5/8Fb	

Sviluppi di calcolo iperstatica

$$L_{BC}^{xx} = \int_0^b (x^2/b^2) 1/EJ dx = [1/3 x^3/b^2]_0^b 1/EJ$$

$$= (1/3 b) 1/EJ = 1/3 b/EJ$$

$$L_{CB}^{xx} = \int_0^b (1 - 2x/b + x^2/b^2) 1/EJ dx = [x - x^2/b + 1/3 x^3/b^2]_0^b 1/EJ$$

$$= (b - b + 1/3 b) 1/EJ = 1/3 b/EJ$$

$$L_{CD}^{xx} = \int_0^b (1) 1/EJ dx = [x]_0^b 1/EJ$$

$$= (b) 1/EJ = b/EJ$$

$$L_{DC}^{xx} = \int_0^b (1) 1/EJ dx = [x]_0^b 1/EJ$$

$$= (b) 1/EJ = b/EJ$$

$$L_{DE}^{xx} = \int_0^b (1 - 2x/b + x^2/b^2) 1/EJ dx = [x - x^2/b + 1/3 x^3/b^2]_0^b 1/EJ$$

$$= (b - b + 1/3 b) 1/EJ = 1/3 b/EJ$$

$$L_{ED}^{xx} = \int_0^b (x^2/b^2) 1/EJ dx = [1/3 x^3/b^2]_0^b 1/EJ$$

$$= (1/3 b) 1/EJ = 1/3 b/EJ$$

$$L_{BC}^{xo} = \int_0^b (-1/2 x/b - 3/2 x^2/b^2) Fb 1/EJ dx = [-1/4 x^2/b - 1/2 x^3/b^2]_0^b Fb 1/EJ$$

$$= (-1/4 b - 1/2 b) Fb 1/EJ = -3/4 Fb^2/EJ$$

$$L_{CB}^{xo} = \int_0^b (-2 + 7/2 x/b - 3/2 x^2/b^2) Fb 1/EJ dx = [-2x + 7/4 x^2/b - 1/2 x^3/b^2]_0^b Fb 1/EJ$$

$$= (-2b + 7/4 b - 1/2 b) Fb 1/EJ = -3/4 Fb^2/EJ$$

$$L_{CD}^{xo} = \int_0^b (-3 + 3x/b) Fb 1/EJ dx = [-3x + 3/2 x^2/b]_0^b Fb 1/EJ$$

$$= (-3b + 3/2 b) Fb 1/EJ = -3/2 Fb^2/EJ$$

$$L_{DC}^{xo} = \int_0^b (-3x/b) Fb 1/EJ dx = [-3/2 x^2/b]_0^b Fb 1/EJ$$

$$= (-3/2 b) Fb 1/EJ = -3/2 Fb^2/EJ$$

$$L_{DE}^{xo} = \int_0^b (3/2 x/b - 2x^2/b^2 + 1/2 x^3/b^3) Fb 1/EJ dx = [3/4 x^2/b - 2/3 x^3/b^2 + 1/8 x^4/b^3]_0^b Fb 1/EJ$$

$$= (3/4 b - 2/3 b + 1/8 b) Fb 1/EJ = 5/24 Fb^2/EJ$$

$$L_{ED}^{xo} = \int_0^b (x/b - 1/2 x^2/b^2 - 1/2 x^3/b^3) Fb 1/EJ dx = [1/2 x^2/b - 1/6 x^3/b^2 - 1/8 x^4/b^3]_0^b Fb 1/EJ$$

$$= (1/2 b - 1/6 b - 1/8 b) Fb 1/EJ = 5/24 Fb^2/EJ$$

- $H_{FB} = -F$
- $V_D = -F$
- $W_C = -W = -Fb$
- $W_G = -W = -Fb$
- $W_E = -W = -Fb$
- $q_{FG} = -q = -F/b$
- $q_{AB} = -q = -F/b$
- $\epsilon_{CD} = -\alpha T = -b^2 F/EJ$
- $k_C = 4EJ/b^3$
- $EJ_{AB} = EJ$
- $EJ_{BC} = EJ$
- $EJ_{CD} = EJ$
- $EJ_{DE} = EJ$
- $EJ_{EF} = EJ$
- $EJ_{FG} = EJ$
- $EJ_{GA} = EJ$
- $EJ_{FB} = EJ$
- $EJ_{BE} = EJ$

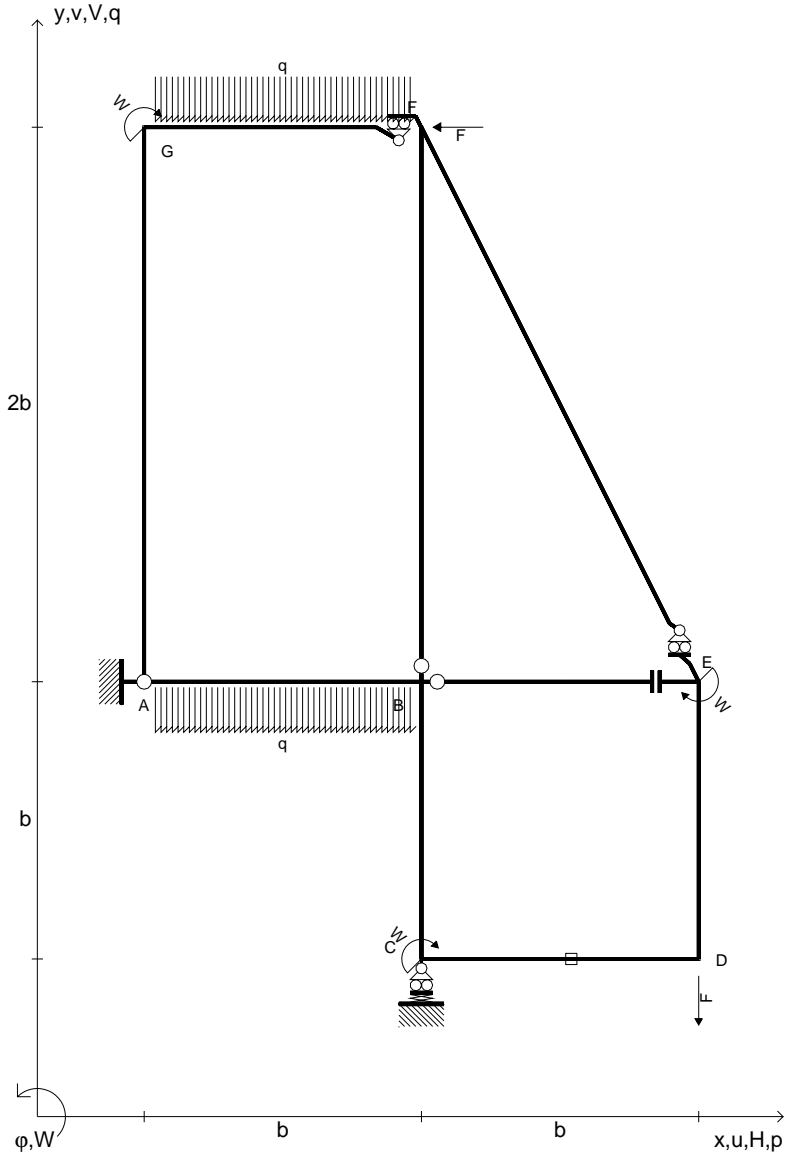

Reazioni iperstatiche in soluzione: $X=W_{DE}$
 Carichi e deformazioni date hanno verso efficace in disegno.
 Calcolare reazioni vincolari della struttura e delle aste.
 Tracciare i diagrammi quotati delle azioni interne nelle aste.
 $J_{YZ} - x_{YZ} - \theta_{YZ}$ riferimento locale asta YZ con origine in Y.
 Elongazione termica specifica ϵ assegnata su asta CD.
 © Adolfo Zavelani Rossi, Politecnico di Milano, vers.27.03.13

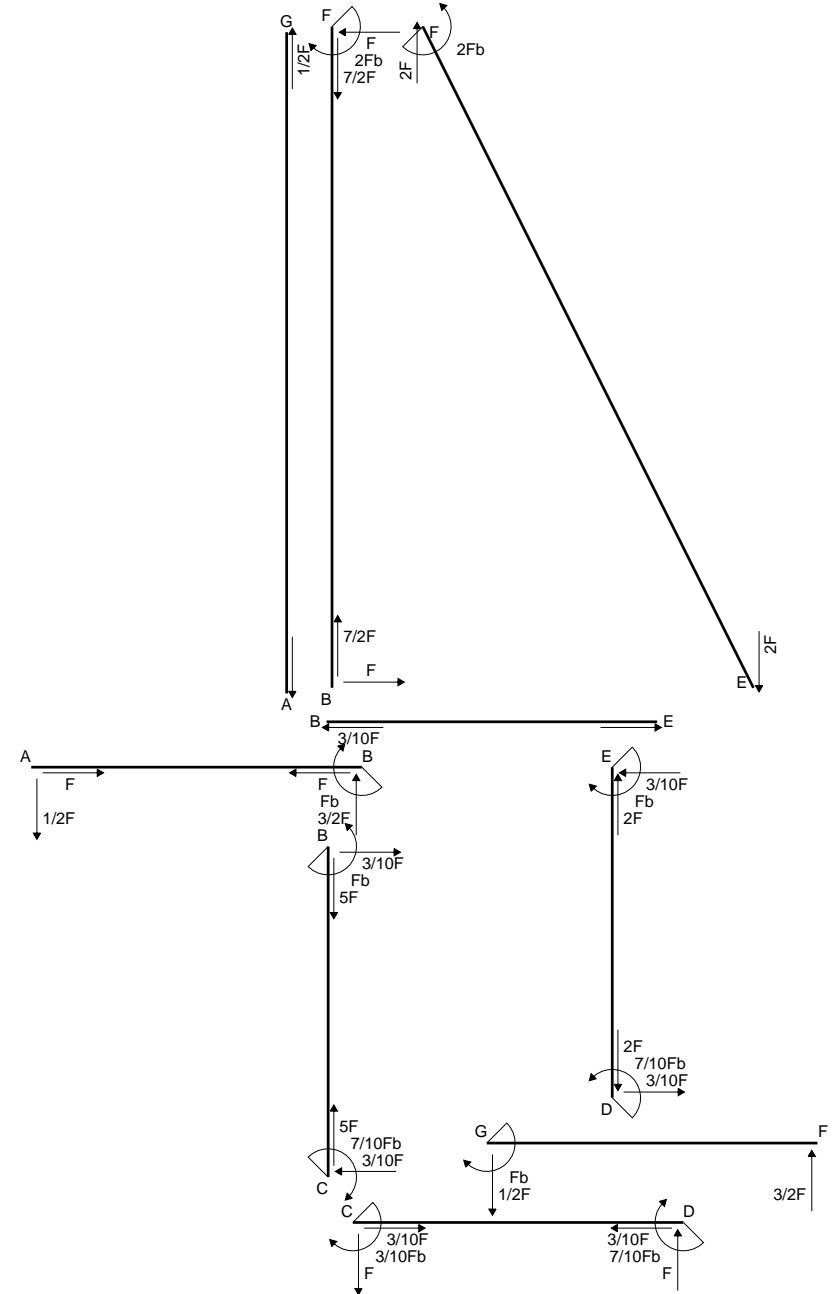

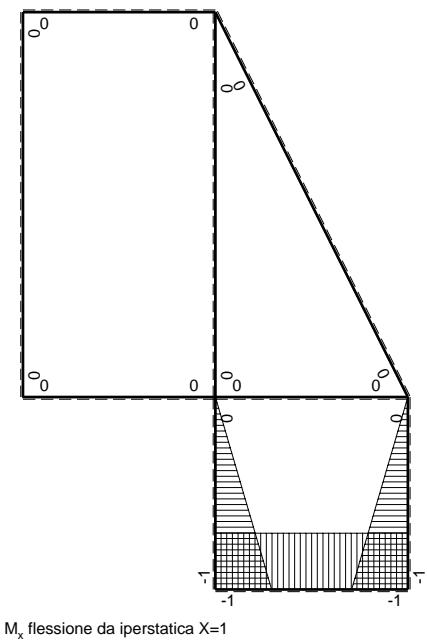
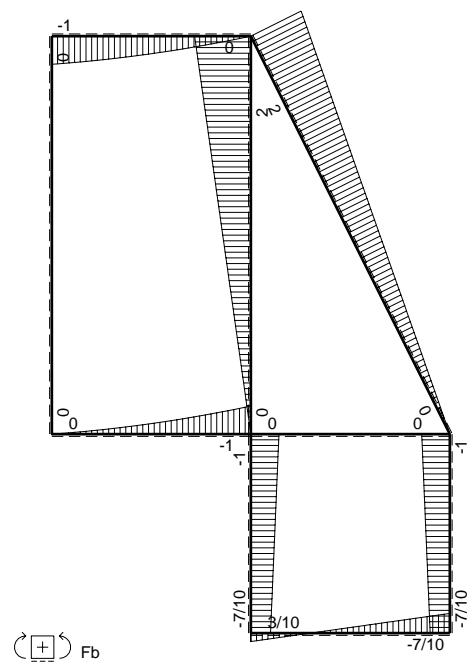
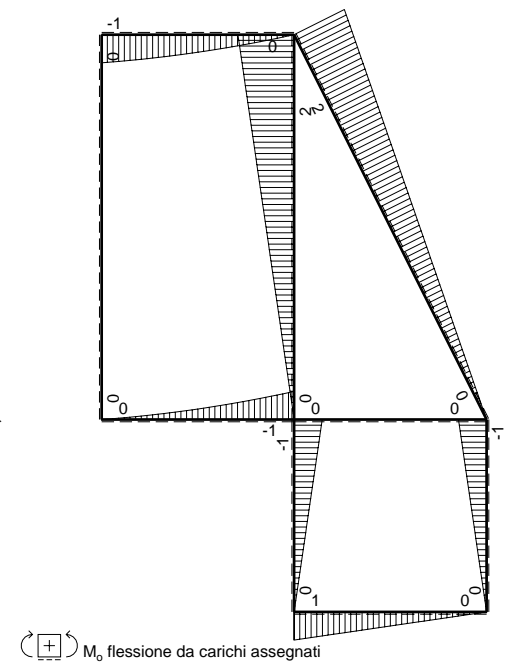
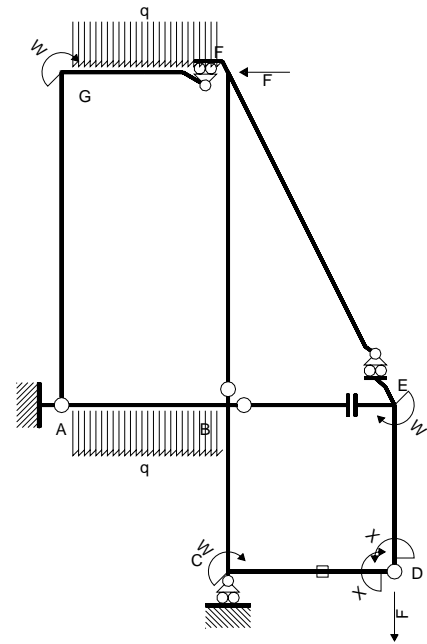
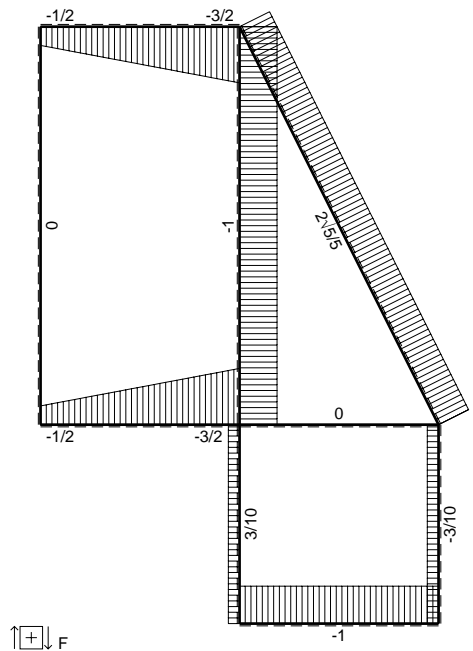
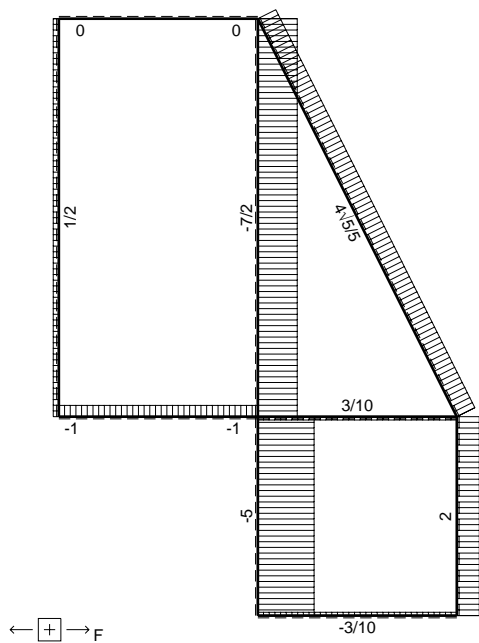

Quadro contributi PLV per iperstatica X=W_{DE}

→	M _x (x)	M _o (x)	M _x M _o	M _x M _x	∫M _x M _o /EJdx	∫XM _x M _x /EJdx
AB b	0	-1/2Fx-1/2qx ²	0	0	0	0
BA b	0	Fb-3/2Fx+1/2qx ²	0	0		
BC b	-x/b	-Fb+Fx	Fx-Fx ² /b	x ² /b ²	1/6Fb ² /EJ	1/3Xb/EJ
CB b	1-x/b	Fx	Fx-Fx ² /b	1-2x/b+x ² /b ²		
CD b	-1	Fb-Fx	-Fb+Fx	1	-1/2Fb ² /EJ	Xb/EJ
DC b	1	-Fx	-Fx	1		
DE b	-1+x/b	-Fx	Fx-Fx ² /b	1-2x/b+x ² /b ²	1/6Fb ² /EJ	1/3Xb/EJ
ED b	x/b	Fb-Fx	Fx-Fx ² /b	x ² /b ²		
EF √5b	0	2√5/5Fx	0	0	0	0
FG b	0	-3/2Fx+1/2qx ²	0	0	0	0
GF b	0	Fb-1/2Fx-1/2qx ²	0	0		
GA 2b	0	0	0	0	0	0
AG 2b	0	0	0	0		
FB 2b	0	2Fb-Fx	0	0	0	0
BF 2b	0	-Fx	0	0		
BE b	0	0	0	0	0	0
EB b	0	0	0	0		
CD	elongazione asta N _{1CD} ε _{CD} L _{CD}				-Fb ² /EJ	
	totali				-7/6Fb ² /EJ	5/3Xb/EJ
	iperstatica X=W _{DE}				7/10Fb	

Sviluppi di calcolo iperstatica

$$L_{BC}^{xx} = \int_0^b (x^2/b^2) 1/EJ dx = [1/3 x^3/b^2]_0^b 1/EJ = (1/3 b) 1/EJ = 1/3 b/EJ$$

$$L_{CB}^{xx} = \int_0^b (1 - 2x/b + x^2/b^2) 1/EJ dx = [x - x^2/b + 1/3 x^3/b^2]_0^b 1/EJ = (b - b + 1/3 b) 1/EJ = 1/3 b/EJ$$

$$L_{CD}^{xx} = \int_0^b (1) 1/EJ dx = [x]_0^b 1/EJ = (b) 1/EJ = b/EJ$$

$$L_{DC}^{xx} = \int_0^b (1) 1/EJ dx = [x]_0^b 1/EJ = (b) 1/EJ = b/EJ$$

$$L_{DE}^{xx} = \int_0^b (1 - 2x/b + x^2/b^2) 1/EJ dx = [x - x^2/b + 1/3 x^3/b^2]_0^b 1/EJ = (b - b + 1/3 b) 1/EJ = 1/3 b/EJ$$

$$L_{ED}^{xx} = \int_0^b (x^2/b^2) 1/EJ dx = [1/3 x^3/b^2]_0^b 1/EJ = (1/3 b) 1/EJ = 1/3 b/EJ$$

$$L_{BC}^{xo} = \int_0^b (x/b - x^2/b^2) Fb 1/EJ dx = [1/2 x^2/b - 1/3 x^3/b^2]_0^b Fb 1/EJ = (1/2 b - 1/3 b) Fb 1/EJ = 1/6 Fb^2/EJ$$

$$L_{CB}^{xo} = \int_0^b (x/b - x^2/b^2) Fb 1/EJ dx = [1/2 x^2/b - 1/3 x^3/b^2]_0^b Fb 1/EJ = (1/2 b - 1/3 b) Fb 1/EJ = 1/6 Fb^2/EJ$$

$$L_{CD}^{xo} = \int_0^b (-1 + x/b) Fb 1/EJ dx + 1 (-1) 1 Fb^2/EJ = [-x + 1/2 x^2/b]_0^b Fb 1/EJ + 1 (-1) 1 Fb^2/EJ = (-b + 1/2 b) Fb 1/EJ + 1 (-1) 1 Fb^2/EJ = -3/2 Fb^2/EJ$$

$$L_{DC}^{xo} = \int_0^b (-x/b) Fb 1/EJ dx + 1 (-1) 1 Fb^2/EJ = [-1/2 x^2/b]_0^b Fb 1/EJ + 1 (-1) 1 Fb^2/EJ = (-1/2 b) Fb 1/EJ + 1 (-1) 1 Fb^2/EJ = -3/2 Fb^2/EJ$$

$$L_{DE}^{xo} = \int_0^b (x/b - x^2/b^2) Fb 1/EJ dx = [1/2 x^2/b - 1/3 x^3/b^2]_0^b Fb 1/EJ = (1/2 b - 1/3 b) Fb 1/EJ = 1/6 Fb^2/EJ$$

$$L_{ED}^{xo} = \int_0^b (x/b - x^2/b^2) Fb 1/EJ dx = [1/2 x^2/b - 1/3 x^3/b^2]_0^b Fb 1/EJ = (1/2 b - 1/3 b) Fb 1/EJ = 1/6 Fb^2/EJ$$

- $H_{FB} = -F$
- $V_D = -F$
- $W_C = -W = -Fb$
- $W_G = -W = -Fb$
- $W_E = -W = -Fb$
- $q_{FG} = -q = -F/b$
- $p_{DE} = -q = -F/b$
- $\epsilon_{BE} = -\alpha T = -b^2 F/EJ$
- $k_C = 4EJ/b^3$
- $EJ_{AB} = EJ$
- $EJ_{BC} = EJ$
- $EJ_{CD} = EJ$
- $EJ_{DE} = EJ$
- $EJ_{EF} = EJ$
- $EJ_{FG} = EJ$
- $EJ_{GA} = EJ$
- $EJ_{FB} = EJ$
- $EJ_{BE} = EJ$

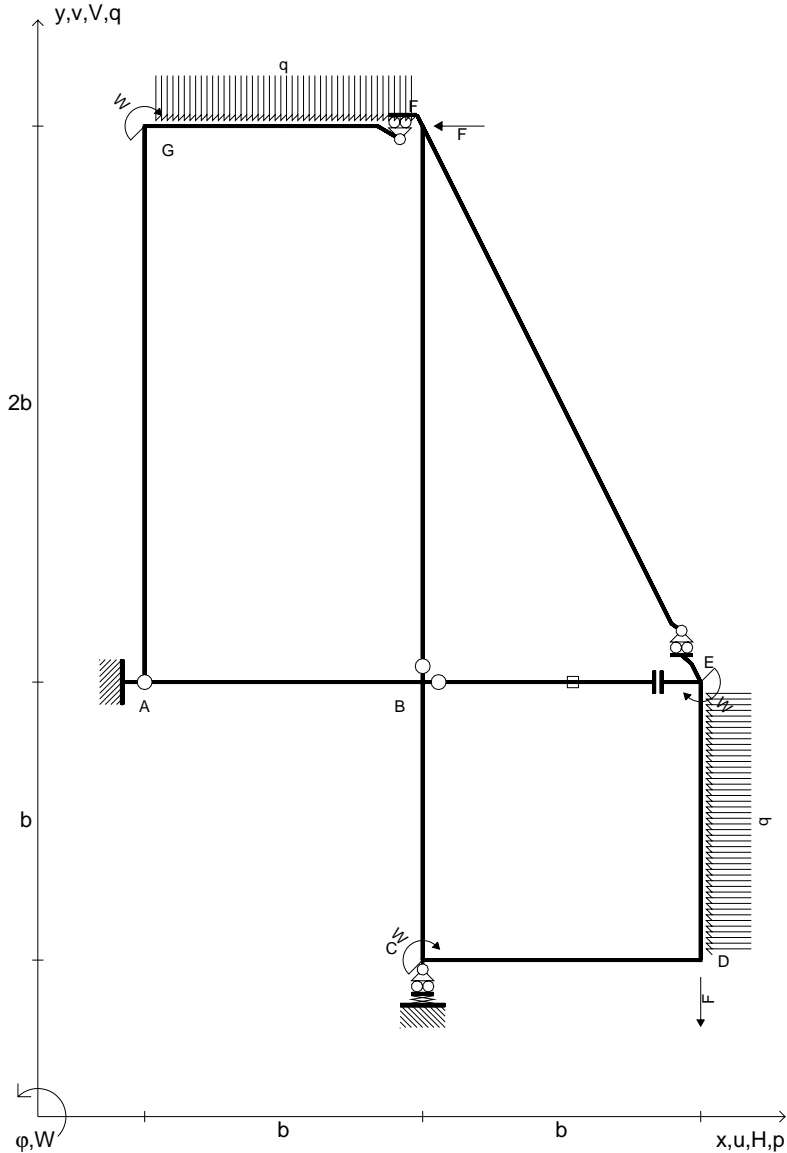

Reazioni iperstatiche in soluzione: $X=H_{BE}$
 Carichi e deformazioni date hanno verso efficace in disegno.
 Calcolare reazioni vincolari della struttura e delle aste.
 Tracciare i diagrammi quotati delle azioni interne nelle aste.
 $J_{YZ} - x_{YZ} - \theta_{YZ}$ riferimento locale asta YZ con origine in Y.
 Elongazione termica specifica ϵ assegnata su asta BE.
 © Adolfo Zavelani Rossi, Politecnico di Milano, vers.27.03.13

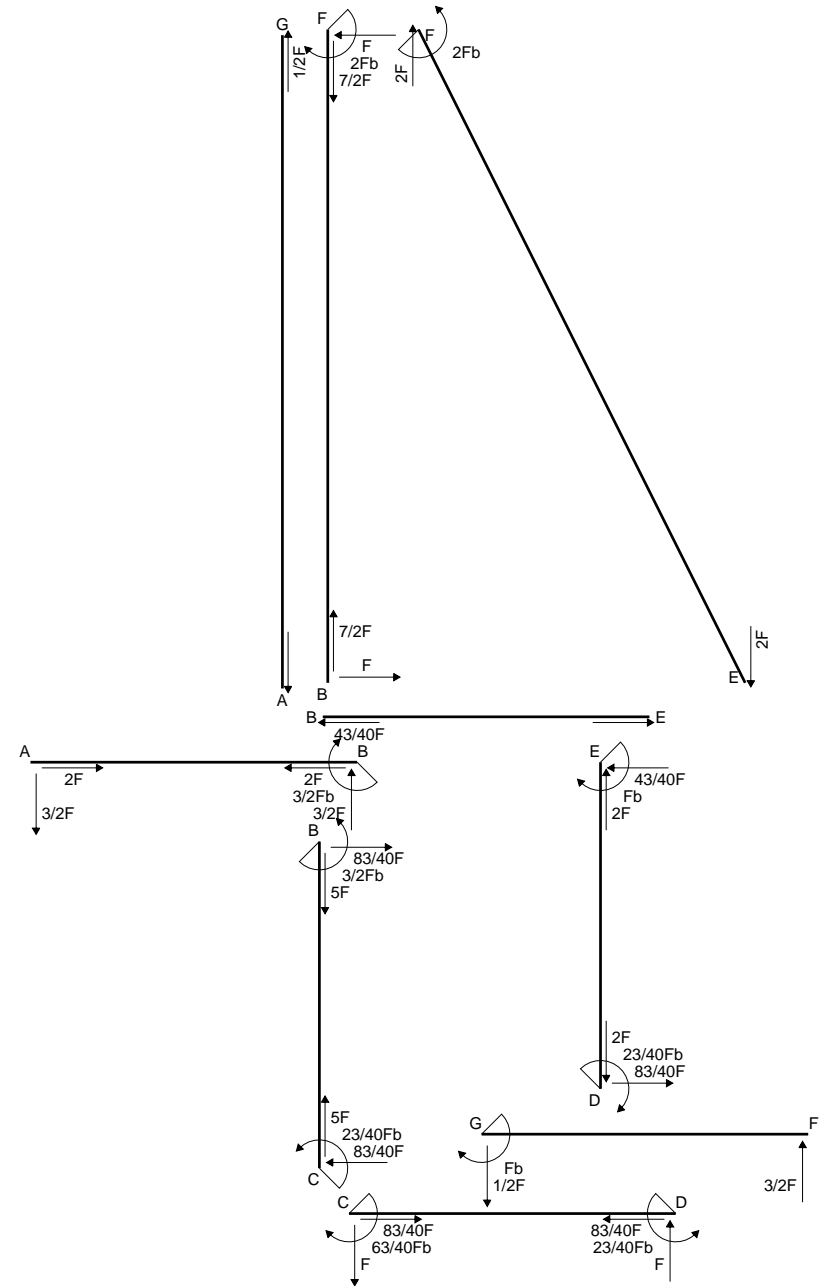

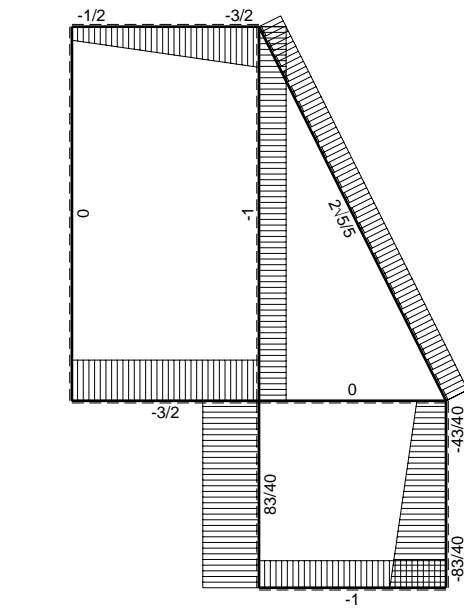
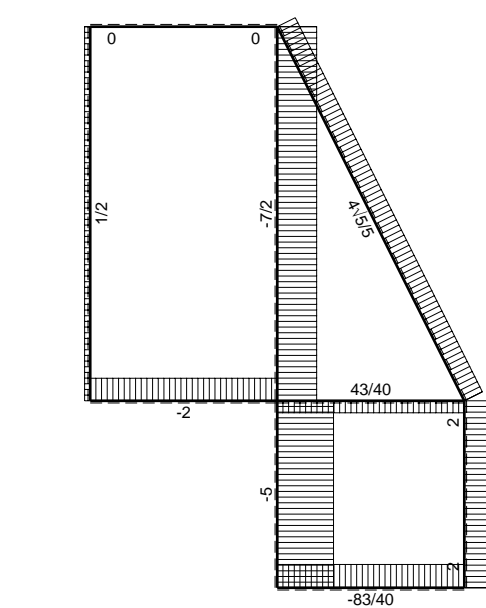

← (+) → F

↑ (+) ↓ F

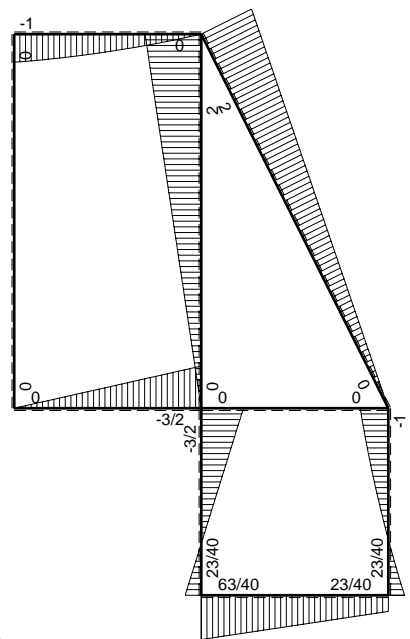

⊙ (+) ⊙ F_b

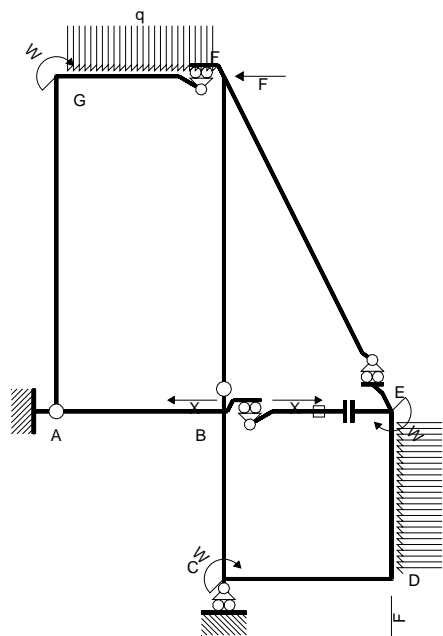

Schema di calcolo iperstatico

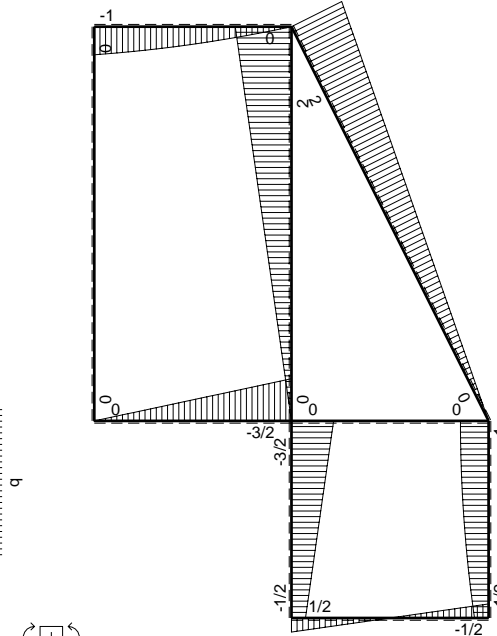

⊙ (+) ⊙ M₀ flessione da carichi assegnati

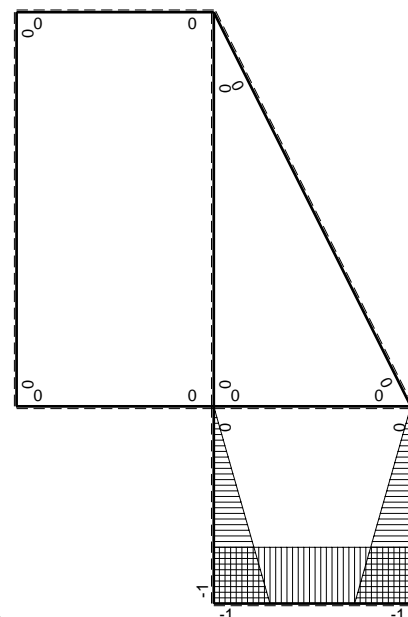

⊙ (+) ⊙ M_x flessione da iperstatica X=1

Quadro contributi PLV per iperstatica X=H_{BE}

→	M _x (x)	M _o (x)	M _x M _o	M _x M _x	∫M _x M _o /EJdx	∫XM _x M _x /EJdx
AB b	0	-3/2Fx	0	0	0	0
BA b	0	3/2Fb-3/2Fx	0	0	0	0
BC b	-x	-3/2Fb+Fx	3/2Fbx-Fx ²	x ²	5/12Fb ³ /EJ	1/3Xb ³ /EJ
CB b	b-x	1/2Fb+Fx	1/2Fb ² +1/2Fbx-Fx ²	b ² -2bx+x ²		
CD b	-b	1/2Fb-Fx	-1/2Fb ² +Fbx	b ²	0	Xb ³ /EJ
DC b	b	1/2Fb-Fx	1/2Fb ² -Fbx	b ²		
DE b	-b+x	-1/2Fb-Fx+1/2qx ²	1/2Fb ² +1/2Fbx-3/2Fx ² +1/2qx ³	b ² -2bx+x ²	3/8Fb ³ /EJ	1/3Xb ³ /EJ
ED b	x	Fb-1/2qx ²	Fbx-1/2qx ³	x ²		
EF √5b	0	2√5/5Fx	0	0	0	0
FG b	0	-3/2Fx+1/2qx ²	0	0	0	0
GF b	0	Fb-1/2Fx-1/2qx ²	0	0	0	0
GA 2b	0	0	0	0	0	0
AG 2b	0	0	0	0	0	0
FB 2b	0	2Fb-Fx	0	0	0	0
BF 2b	0	-Fx	0	0	0	0
BE b	0	0	0	0	0	0
EB b	0	0	0	0	0	0
BE	elongazione asta N _{1BE} ε _{BE} L _{BE}				Fb ³ /EJ	
	totali				43/24Fb ³ /EJ	5/3Xb ³ /EJ
	iperstatica X=H _{BE}				-43/40F	

Sviluppi di calcolo iperstatica

$$L_{BC}^{XX} = \int_0^b (x^2/b^2) b^2 1/EJ dx = [1/3 x^3/b^2]_0^b b^2 1/EJ$$

$$= (1/3 b) b^2 1/EJ = 1/3 b^3/EJ$$

$$L_{CB}^{XX} = \int_0^b (1 - 2x/b + x^2/b^2) b^2 1/EJ dx = [x - x^2/b + 1/3 x^3/b^2]_0^b b^2 1/EJ$$

$$= (b - b + 1/3 b) b^2 1/EJ = 1/3 b^3/EJ$$

$$L_{CD}^{XX} = \int_0^b (1) b^2 1/EJ dx = [x]_0^b b^2 1/EJ$$

$$= (b) b^2 1/EJ = b^3/EJ$$

$$L_{DC}^{XX} = \int_0^b (1) b^2 1/EJ dx = [x]_0^b b^2 1/EJ$$

$$= (b) b^2 1/EJ = b^3/EJ$$

$$L_{DE}^{XX} = \int_0^b (1 - 2x/b + x^2/b^2) b^2 1/EJ dx = [x - x^2/b + 1/3 x^3/b^2]_0^b b^2 1/EJ$$

$$= (b - b + 1/3 b) b^2 1/EJ = 1/3 b^3/EJ$$

$$L_{ED}^{XX} = \int_0^b (x^2/b^2) b^2 1/EJ dx = [1/3 x^3/b^2]_0^b b^2 1/EJ$$

$$= (1/3 b) b^2 1/EJ = 1/3 b^3/EJ$$

$$L_{BC}^{Xo} = \int_0^b (3/2 x/b - x^2/b^2) Fb^2 1/EJ dx = [3/4 x^2/b - 1/3 x^3/b^2]_0^b Fb^2 1/EJ$$

$$= (3/4 b - 1/3 b) Fb^2 1/EJ = 5/12 Fb^3/EJ$$

$$L_{CB}^{Xo} = \int_0^b (1/2 + 1/2 x/b - x^2/b^2) Fb^2 1/EJ dx = [1/2 x + 1/4 x^2/b - 1/3 x^3/b^2]_0^b Fb^2 1/EJ$$

$$= (1/2 b + 1/4 b - 1/3 b) Fb^2 1/EJ = 5/12 Fb^3/EJ$$

$$L_{CD}^{Xo} = \int_0^b (-1/2 + x/b) Fb^2 1/EJ dx = [-1/2 x + 1/2 x^2/b]_0^b Fb^2 1/EJ$$

$$= (-1/2 b + 1/2 b) Fb^2 1/EJ = 0$$

$$L_{DC}^{Xo} = \int_0^b (1/2 - x/b) Fb^2 1/EJ dx = [1/2 x - 1/2 x^2/b]_0^b Fb^2 1/EJ$$

$$= (1/2 b - 1/2 b) Fb^2 1/EJ = 0$$

$$L_{DE}^{Xo} = \int_0^b (1/2 + 1/2 x/b - 3/2 x^2/b^2 + 1/2 x^3/b^3) Fb^2 1/EJ dx$$

$$= [1/2 x + 1/4 x^2/b - 1/2 x^3/b^2 + 1/8 x^4/b^3]_0^b Fb^2 1/EJ$$

$$= (1/2 b + 1/4 b - 1/2 b + 1/8 b) Fb^2 1/EJ = 3/8 Fb^3/EJ$$

$$L_{ED}^{Xo} = \int_0^b (x/b - 1/2 x^3/b^3) Fb^2 1/EJ dx = [1/2 x^2/b - 1/8 x^4/b^3]_0^b Fb^2 1/EJ$$

$$= (1/2 b - 1/8 b) Fb^2 1/EJ = 3/8 Fb^3/EJ$$

- $H_{FB} = -F$
- $V_D = -F$
- $W_C = -W = -Fb$
- $W_G = -W = -Fb$
- $W_E = -W = -Fb$
- $q_{FG} = -q = -F/b$
- $p_{DE} = -q = -F/b$
- $\epsilon_{CD} = -\alpha T = -b^2 F/EJ$
- $k_C = 4EJ/b^3$
- $EJ_{AB} = EJ$
- $EJ_{BC} = EJ$
- $EJ_{CD} = EJ$
- $EJ_{DE} = EJ$
- $EJ_{EF} = EJ$
- $EJ_{FG} = EJ$
- $EJ_{GA} = EJ$
- $EJ_{FB} = EJ$
- $EJ_{BE} = EJ$

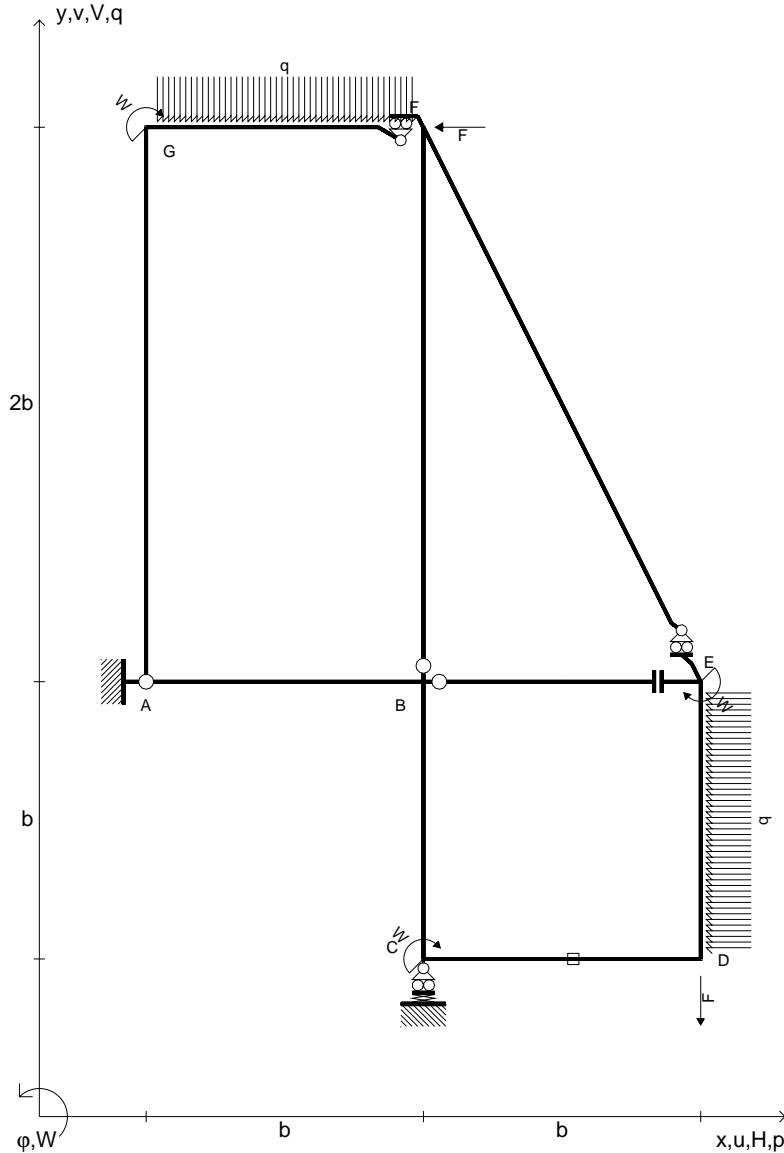

Reazioni iperstatiche in soluzione: $X=W_{DC}$
 Carichi e deformazioni date hanno verso efficace in disegno.
 Calcolare reazioni vincolari della struttura e delle aste.
 Tracciare i diagrammi quotati delle azioni interne nelle aste.
 $J_{YZ} - x_{YZ} - \theta_{YZ}$ riferimento locale asta YZ con origine in Y.
 Elongazione termica specifica ϵ assegnata su asta CD.
 @ Adolfo Zavelani Rossi, Politecnico di Milano, vers.27.03.13

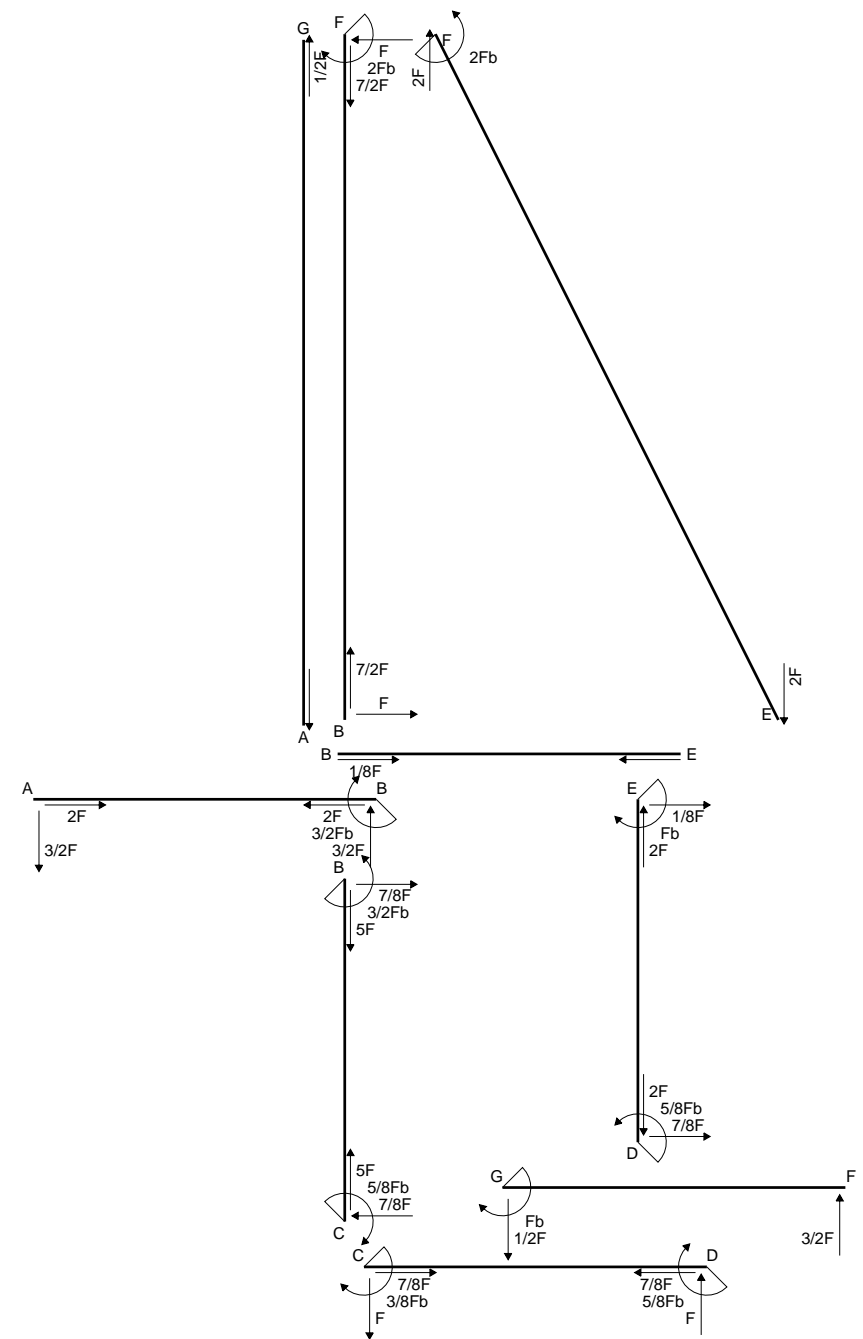

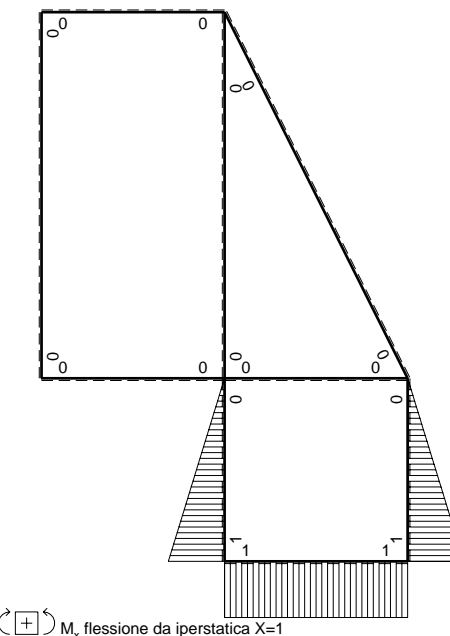
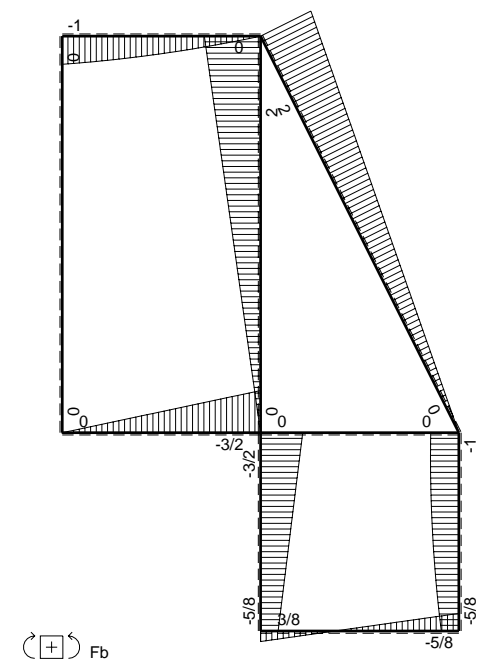
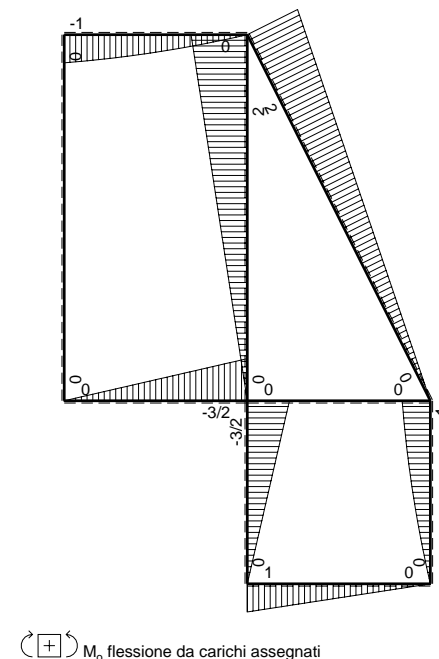
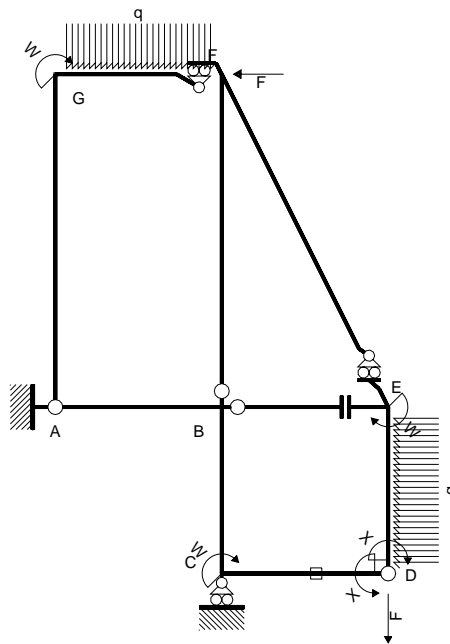
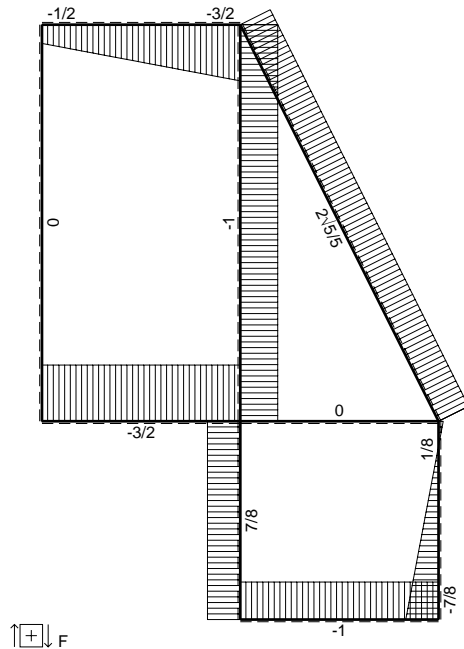
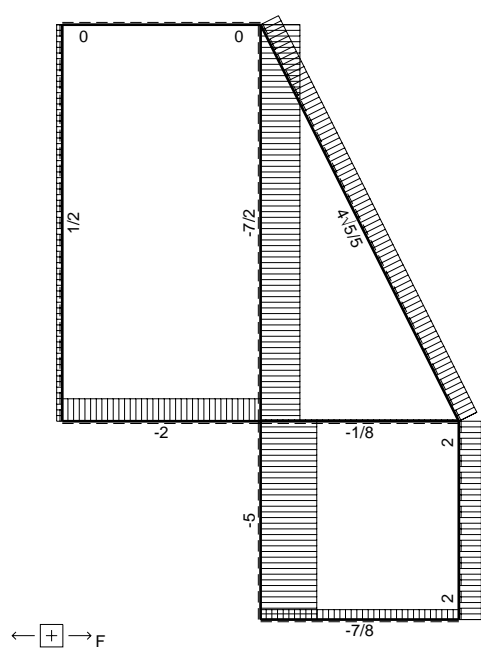

Quadro contributi PLV per iperstatica X=W_{DC}

→	M _x (x)	M _o (x)	M _x M _o	M _x M _x	∫M _x M _o /EJdx	∫xM _x M _x /EJdx
AB b	0	-3/2Fx	0	0	0	0
BA b	0	3/2Fb-3/2Fx	0	0	0	0
BC b	x/b	-3/2Fb+3/2Fx	-3/2Fx+3/2Fx ² /b	x ² /b ²	-1/4Fb ² /EJ	1/3Xb/EJ
CB b	-1+x/b	3/2Fx	-3/2Fx+3/2Fx ² /b	1-2x/b+x ² /b ²	-1/4Fb ² /EJ	1/3Xb/EJ
CD b	1	Fb-Fx	Fb-Fx	1	1/2Fb ² /EJ	Xb/EJ
DC b	-1	-Fx	Fx	1	1/2Fb ² /EJ	Xb/EJ
DE b	1-x/b	-3/2Fx+1/2qx ²	-3/2Fx+2Fx ² /b-1/2qx ³ /b	1-2x/b+x ² /b ²	-5/24Fb ² /EJ	1/3Xb/EJ
ED b	-x/b	Fb-1/2Fx-1/2qx ²	-Fx+1/2Fx ² /b+1/2qx ³ /b	x ² /b ²	-5/24Fb ² /EJ	1/3Xb/EJ
EF √5b	0	2√5/5Fx	0	0	0	0
FG b	0	-3/2Fx+1/2qx ²	0	0	0	0
GF b	0	Fb-1/2Fx-1/2qx ²	0	0	0	0
GA 2b	0	0	0	0	0	0
AG 2b	0	0	0	0	0	0
FB 2b	0	2Fb-Fx	0	0	0	0
BF 2b	0	-Fx	0	0	0	0
BE b	0	0	0	0	0	0
EB b	0	0	0	0	0	0
CD	elongazione asta N _{1CD} ε _{CD} L _{CD}				Fb ² /EJ	
	totali				25/24Fb ² /EJ	5/3Xb/EJ
	iperstatica X=W _{DC}				-5/8Fb	

Sviluppi di calcolo iperstatica

$$L_{BC}^{xx} = \int_0^b (x^2/b^2) 1/EJ dx = [1/3 x^3/b^2]_0^b 1/EJ = (1/3 b) 1/EJ = 1/3 b/EJ$$

$$L_{CB}^{xx} = \int_0^b (1 - 2x/b + x^2/b^2) 1/EJ dx = [x - x^2/b + 1/3 x^3/b^2]_0^b 1/EJ = (b - b + 1/3 b) 1/EJ = 1/3 b/EJ$$

$$L_{CD}^{xx} = \int_0^b (1) 1/EJ dx = [x]_0^b 1/EJ = (b) 1/EJ = b/EJ$$

$$L_{DC}^{xx} = \int_0^b (1) 1/EJ dx = [x]_0^b 1/EJ = (b) 1/EJ = b/EJ$$

$$L_{DE}^{xx} = \int_0^b (1 - 2x/b + x^2/b^2) 1/EJ dx = [x - x^2/b + 1/3 x^3/b^2]_0^b 1/EJ = (b - b + 1/3 b) 1/EJ = 1/3 b/EJ$$

$$L_{ED}^{xx} = \int_0^b (x^2/b^2) 1/EJ dx = [1/3 x^3/b^2]_0^b 1/EJ = (1/3 b) 1/EJ = 1/3 b/EJ$$

$$L_{BC}^{xo} = \int_0^b (-3/2 x/b + 3/2 x^2/b^2) Fb 1/EJ dx = [-3/4 x^2/b + 1/2 x^3/b^2]_0^b Fb 1/EJ = (-3/4 b + 1/2 b) Fb 1/EJ = -1/4 Fb^2/EJ$$

$$L_{CB}^{xo} = \int_0^b (-3/2 x/b + 3/2 x^2/b^2) Fb 1/EJ dx = [-3/4 x^2/b + 1/2 x^3/b^2]_0^b Fb 1/EJ = (-3/4 b + 1/2 b) Fb 1/EJ = -1/4 Fb^2/EJ$$

$$L_{CD}^{xo} = \int_0^b (1 - x/b) Fb 1/EJ dx - 1 (-1) 1 Fb^2/EJ = [x - 1/2 x^2/b]_0^b Fb 1/EJ - 1 (-1) 1 Fb^2/EJ = (b - 1/2 b) Fb 1/EJ - 1 (-1) 1 Fb^2/EJ = 3/2 Fb^2/EJ$$

$$L_{DC}^{xo} = \int_0^b (x/b) Fb 1/EJ dx - 1 (-1) 1 Fb^2/EJ = [1/2 x^2/b]_0^b Fb 1/EJ - 1 (-1) 1 Fb^2/EJ = (1/2 b) Fb 1/EJ - 1 (-1) 1 Fb^2/EJ = 3/2 Fb^2/EJ$$

$$L_{DE}^{xo} = \int_0^b (-3/2 x/b + 2 x^2/b^2 - 1/2 x^3/b^3) Fb 1/EJ dx = [-3/4 x^2/b + 2/3 x^3/b^2 - 1/8 x^4/b^3]_0^b Fb 1/EJ = (-3/4 b + 2/3 b - 1/8 b) Fb 1/EJ = -5/24 Fb^2/EJ$$

$$L_{ED}^{xo} = \int_0^b (-x/b + 1/2 x^2/b^2 + 1/2 x^3/b^3) Fb 1/EJ dx = [-1/2 x^2/b + 1/6 x^3/b^2 + 1/8 x^4/b^3]_0^b Fb 1/EJ = (-1/2 b + 1/6 b + 1/8 b) Fb 1/EJ = -5/24 Fb^2/EJ$$

- $H_{FB} = -F$
- $V_D = -F$
- $W_C = -W = -Fb$
- $W_G = -W = -Fb$
- $W_E = -W = -Fb$
- $p_{DE} = -q = -F/b$
- $q_{CD} = -q = -F/b$
- $\epsilon_{CD} = -\alpha T = -b^2 F/EJ$
- $k_C = 4EJ/b^3$
- $EJ_{AB} = EJ$
- $EJ_{BC} = EJ$
- $EJ_{CD} = EJ$
- $EJ_{DE} = EJ$
- $EJ_{EF} = EJ$
- $EJ_{FG} = EJ$
- $EJ_{GA} = EJ$
- $EJ_{FB} = EJ$
- $EJ_{BE} = EJ$

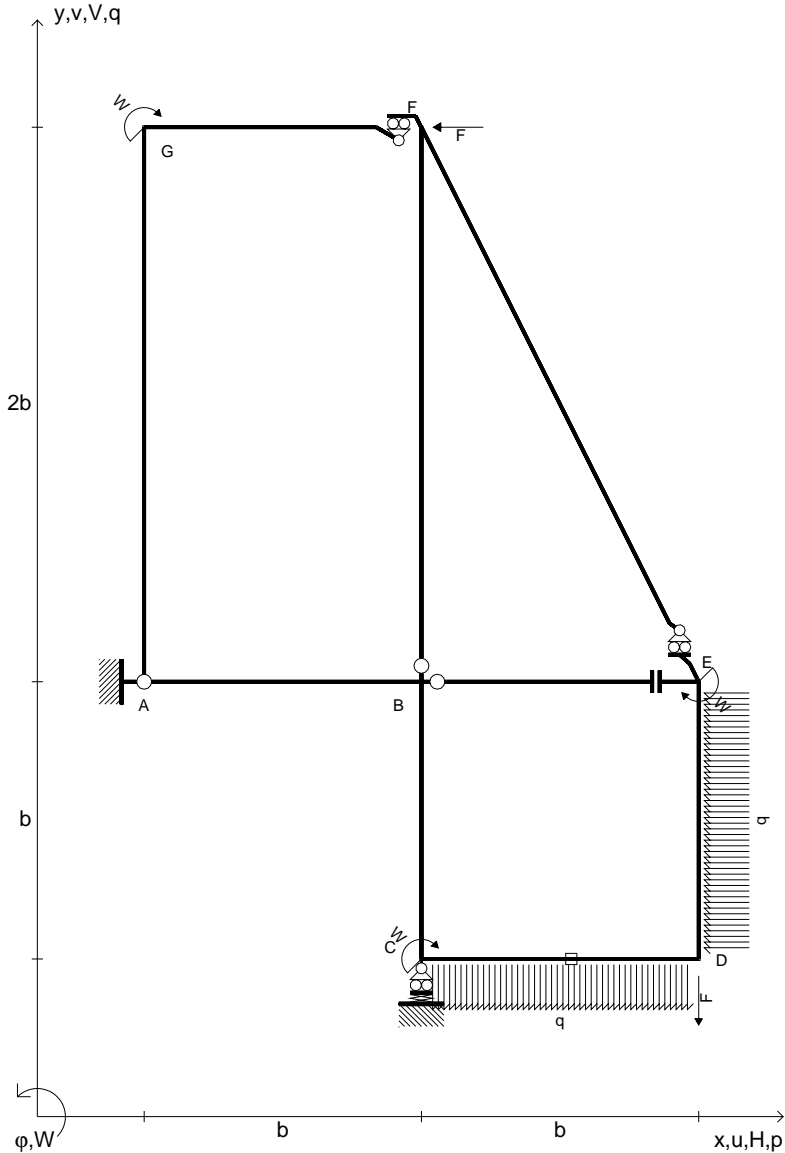

Reazioni iperstatiche in soluzione: $X=W_{DC}$
 Carichi e deformazioni date hanno verso efficace in disegno.
 Calcolare reazioni vincolari della struttura e delle aste.
 Tracciare i diagrammi quotati delle azioni interne nelle aste.
 $J_{YZ} - x_{YZ} - \theta_{YZ}$ riferimento locale asta YZ con origine in Y.
 Elongazione termica specifica ϵ assegnata su asta CD.
 @ Adolfo Zavelani Rossi, Politecnico di Milano, vers.27.03.13

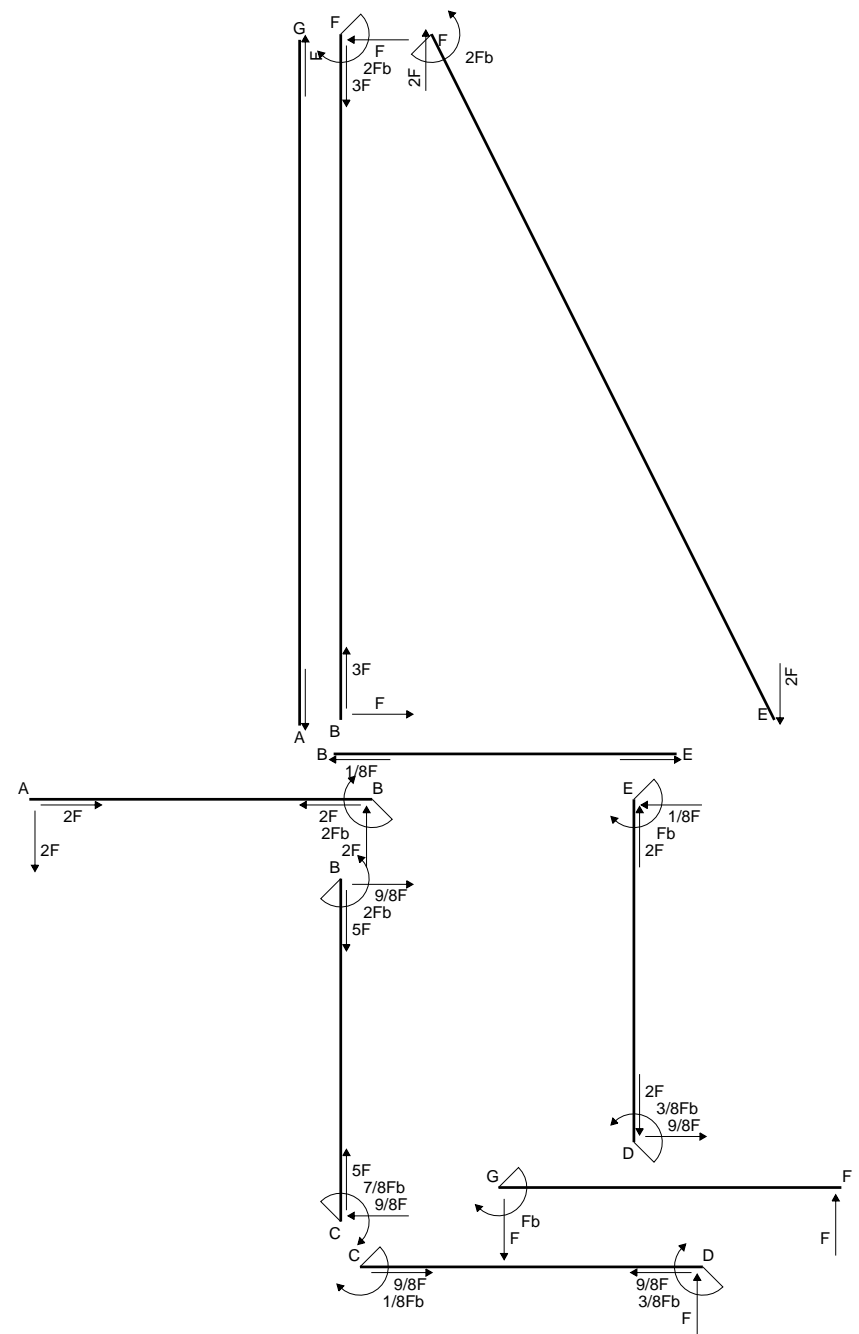

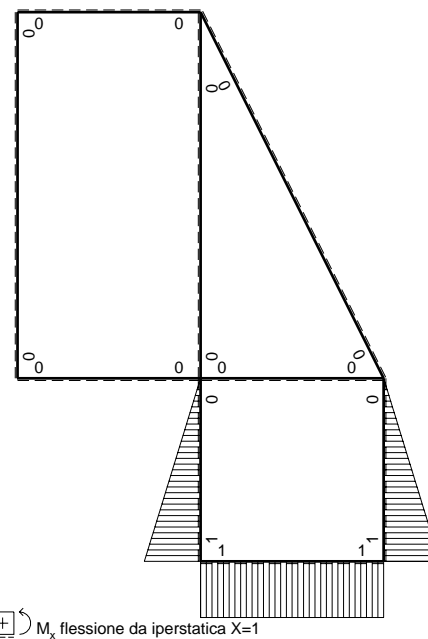
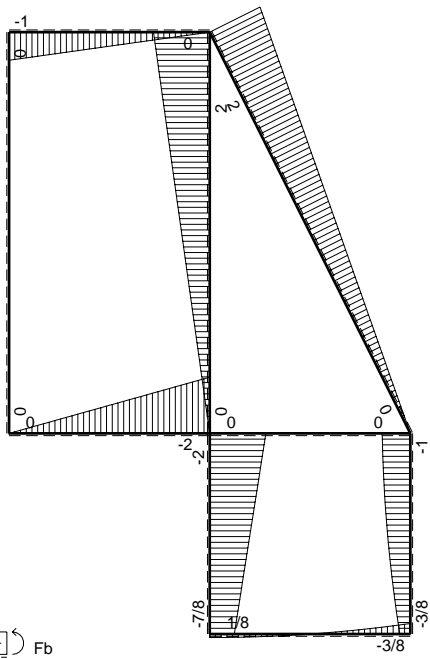
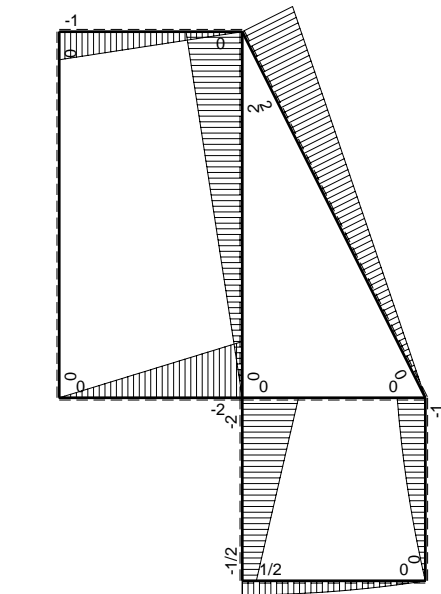
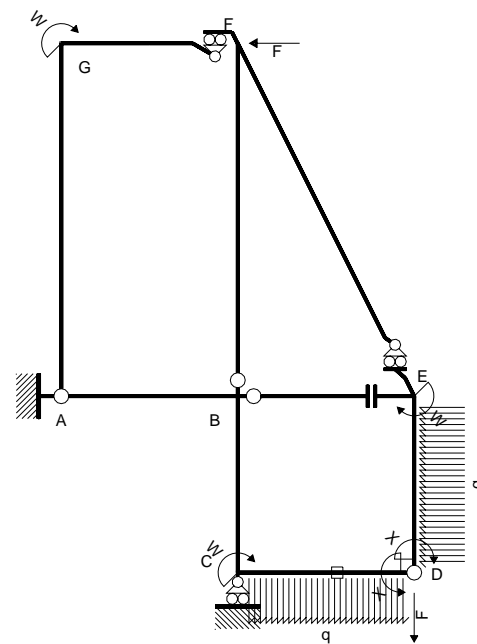
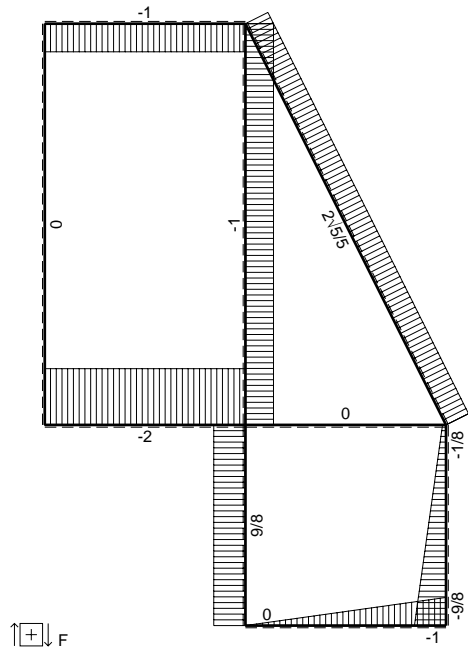
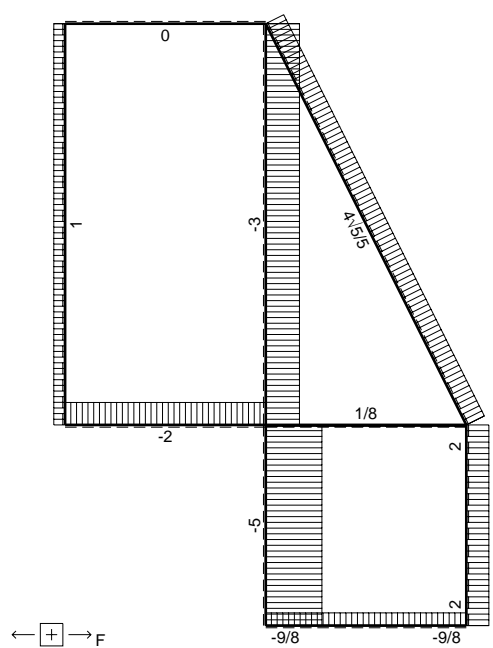

Quadro contributi PLV per iperstatica X=W_{DC}

→	M _x (x)	M _o (x)	M _x M _o	M _x M _x	∫M _x M _o /EJdx	∫XM _x M _x /EJdx
AB b	0	-2Fx	0	0	0	0
BA b	0	2Fb-2Fx	0	0	0	0
BC b	x/b	-2Fb+3/2Fx	-2Fx+3/2Fx ² /b	x ² /b ²	-1/2Fb ² /EJ	1/3Xb/EJ
CB b	-1+x/b	1/2Fb+3/2Fx	-1/2Fb-Fx+3/2Fx ² /b	1-2x/b+x ² /b ²	-5/24Fb ² /EJ	1/3Xb/EJ
CD b	1	1/2Fb-1/2qx ²	1/2Fb-1/2Fx ² /b	1	1/3Fb ² /EJ	Xb/EJ
DC b	-1	-Fx+1/2qx ²	Fx-1/2Fx ² /b	1	1/3Fb ² /EJ	Xb/EJ
DE b	1-x/b	-3/2Fx+1/2qx ²	-3/2Fx+2Fx ² /b-1/2qx ³ /b	1-2x/b+x ² /b ²	-5/24Fb ² /EJ	1/3Xb/EJ
ED b	-x/b	Fb-1/2Fx-1/2qx ²	-Fx+1/2Fx ² /b+1/2qx ³ /b	x ² /b ²	-5/24Fb ² /EJ	1/3Xb/EJ
EF √5b	0	2√5/5Fx	0	0	0	0
FG b	0	-Fx	0	0	0	0
GF b	0	Fb-Fx	0	0	0	0
GA 2b	0	0	0	0	0	0
AG 2b	0	0	0	0	0	0
FB 2b	0	2Fb-Fx	0	0	0	0
BF 2b	0	-Fx	0	0	0	0
BE b	0	0	0	0	0	0
EB b	0	0	0	0	0	0
CD	elongazione asta N _{1CD} ε _{CD} L _{CD}				Fb ² /EJ	
	totali				5/8Fb ² /EJ	5/3Xb/EJ
	iperstatica X=W _{DC}				-3/8Fb	

Sviluppi di calcolo iperstatica

$$L_{BC}^{xx} = \int_0^b (x^2/b^2) 1/EJ dx = [1/3 x^3/b^2]_0^b 1/EJ = (1/3 b) 1/EJ = 1/3 b/EJ$$

$$L_{CB}^{xx} = \int_0^b (1 - 2x/b + x^2/b^2) 1/EJ dx = [x - x^2/b + 1/3 x^3/b^2]_0^b 1/EJ = (b - b + 1/3 b) 1/EJ = 1/3 b/EJ$$

$$L_{CD}^{xx} = \int_0^b (1) 1/EJ dx = [x]_0^b 1/EJ = (b) 1/EJ = b/EJ$$

$$L_{DC}^{xx} = \int_0^b (1) 1/EJ dx = [x]_0^b 1/EJ = (b) 1/EJ = b/EJ$$

$$L_{DE}^{xx} = \int_0^b (1 - 2x/b + x^2/b^2) 1/EJ dx = [x - x^2/b + 1/3 x^3/b^2]_0^b 1/EJ = (b - b + 1/3 b) 1/EJ = 1/3 b/EJ$$

$$L_{ED}^{xx} = \int_0^b (x^2/b^2) 1/EJ dx = [1/3 x^3/b^2]_0^b 1/EJ = (1/3 b) 1/EJ = 1/3 b/EJ$$

$$L_{BC}^{xo} = \int_0^b (-2x/b + 3/2 x^2/b^2) Fb 1/EJ dx = [-x^2/b + 1/2 x^3/b^2]_0^b Fb 1/EJ = (-b + 1/2 b) Fb 1/EJ = -1/2 Fb^2/EJ$$

$$L_{CB}^{xo} = \int_0^b (-1/2 - x/b + 3/2 x^2/b^2) Fb 1/EJ dx = [-1/2 x - 1/2 x^2/b + 1/2 x^3/b^2]_0^b Fb 1/EJ = (-1/2 b - 1/2 b + 1/2 b) Fb 1/EJ = -1/2 Fb^2/EJ$$

$$L_{CD}^{xo} = \int_0^b (1/2 - 1/2 x^2/b^2) Fb 1/EJ dx - 1 (-1) 1 Fb^2/EJ = [1/2 x - 1/6 x^3/b^2]_0^b Fb 1/EJ - 1 (-1) 1 Fb^2/EJ = (1/2 b - 1/6 b) Fb 1/EJ - 1 (-1) 1 Fb^2/EJ = 4/3 Fb^2/EJ$$

$$L_{DC}^{xo} = \int_0^b (x/b - 1/2 x^2/b^2) Fb 1/EJ dx - 1 (-1) 1 Fb^2/EJ = [1/2 x^2/b - 1/6 x^3/b^2]_0^b Fb 1/EJ - 1 (-1) 1 Fb^2/EJ = (1/2 b - 1/6 b) Fb 1/EJ - 1 (-1) 1 Fb^2/EJ = 4/3 Fb^2/EJ$$

$$L_{DE}^{xo} = \int_0^b (-3/2 x/b + 2 x^2/b^2 - 1/2 x^3/b^3) Fb 1/EJ dx = [-3/4 x^2/b + 2/3 x^3/b^2 - 1/8 x^4/b^3]_0^b Fb 1/EJ = (-3/4 b + 2/3 b - 1/8 b) Fb 1/EJ = -5/24 Fb^2/EJ$$

$$L_{ED}^{xo} = \int_0^b (-x/b + 1/2 x^2/b^2 + 1/2 x^3/b^3) Fb 1/EJ dx = [-1/2 x^2/b + 1/6 x^3/b^2 + 1/8 x^4/b^3]_0^b Fb 1/EJ = (-1/2 b + 1/6 b + 1/8 b) Fb 1/EJ = -5/24 Fb^2/EJ$$

$$L_{EB}^{xo} = \int_0^b (-x/b + 1/2 x^2/b^2 + 1/2 x^3/b^3) Fb 1/EJ dx = [-1/2 x^2/b + 1/6 x^3/b^2 + 1/8 x^4/b^3]_0^b Fb 1/EJ = (-1/2 b + 1/6 b + 1/8 b) Fb 1/EJ = -5/24 Fb^2/EJ$$

- $H_{FB} = -F$
- $V_D = -F$
- $W_C = -W = -Fb$
- $W_G = -W = -Fb$
- $W_E = -W = -Fb$
- $p_{DE} = -q = -F/b$
- $p_{FB} = -q = -F/b$
- $\epsilon_{CD} = -\alpha T = -b^2 F/EJ$
- $k_C = 4EJ/b^3$
- $EJ_{AB} = EJ$
- $EJ_{BC} = EJ$
- $EJ_{CD} = EJ$
- $EJ_{DE} = EJ$
- $EJ_{EF} = EJ$
- $EJ_{FG} = EJ$
- $EJ_{GA} = EJ$
- $EJ_{FB} = EJ$
- $EJ_{BE} = EJ$

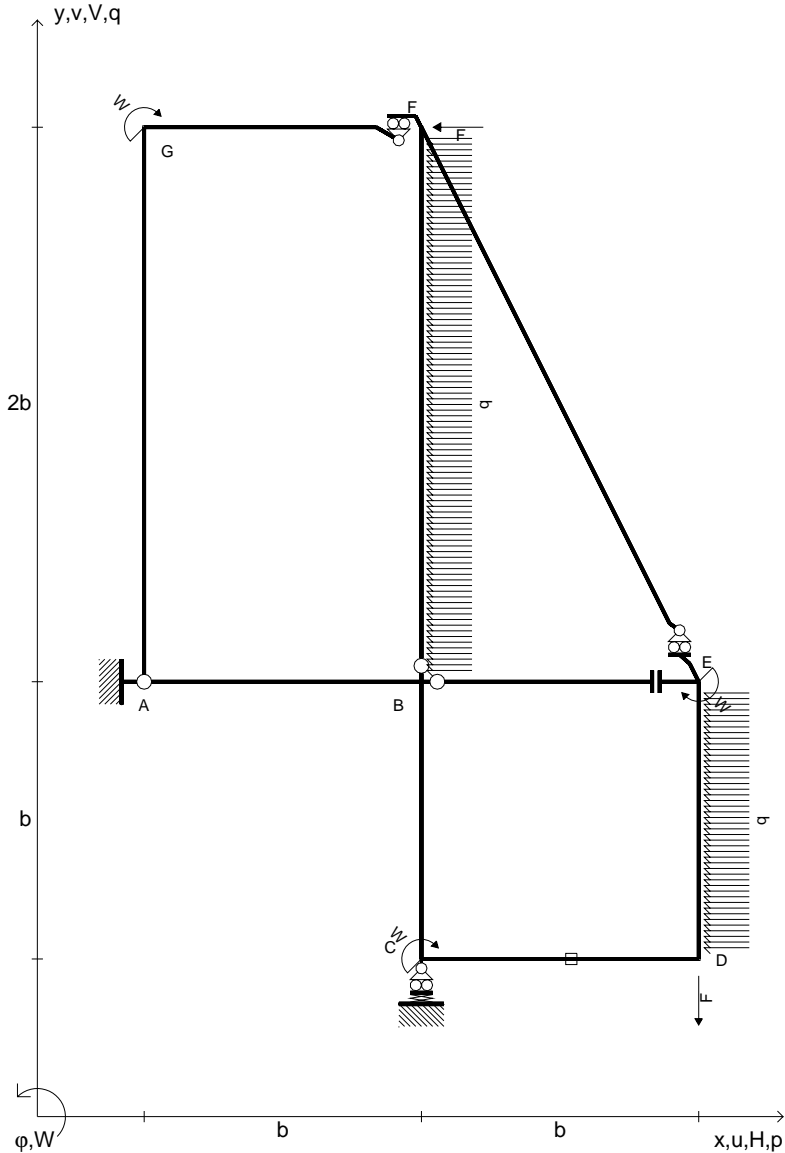

Reazioni iperstatiche in soluzione: $X=W_{DE}$
 Carichi e deformazioni date hanno verso efficace in disegno.
 Calcolare reazioni vincolari della struttura e delle aste.
 Tracciare i diagrammi quotati delle azioni interne nelle aste.
 $J_{YZ} - x_{YZ} - \theta_{YZ}$ riferimento locale asta YZ con origine in Y.
 Elongazione termica specifica ϵ assegnata su asta CD.
 @ Adolfo Zavelani Rossi, Politecnico di Milano, vers.27.03.13

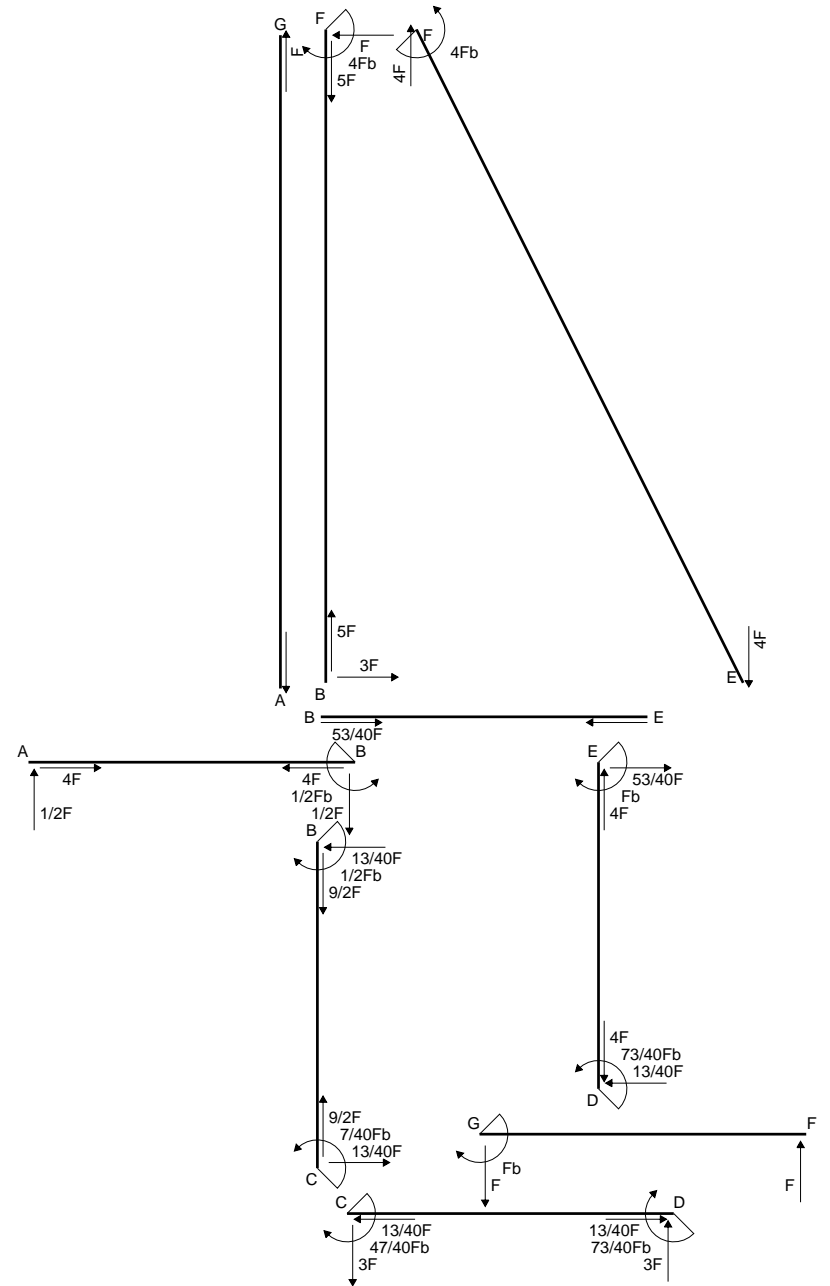

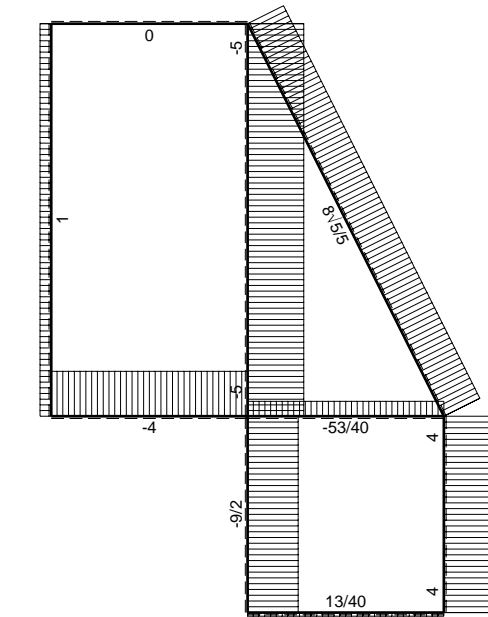

← ⊕ → F

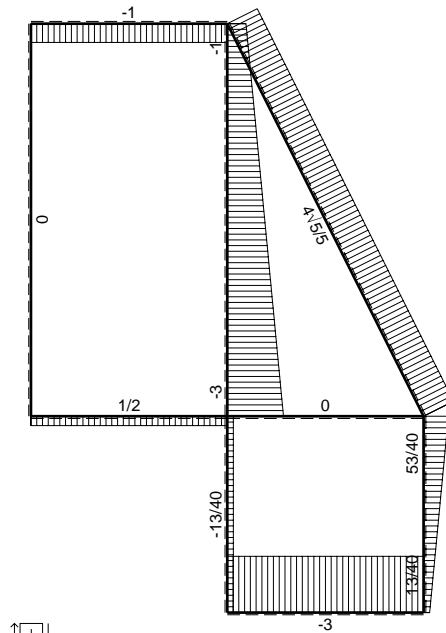

↑ ⊕ ↓ F

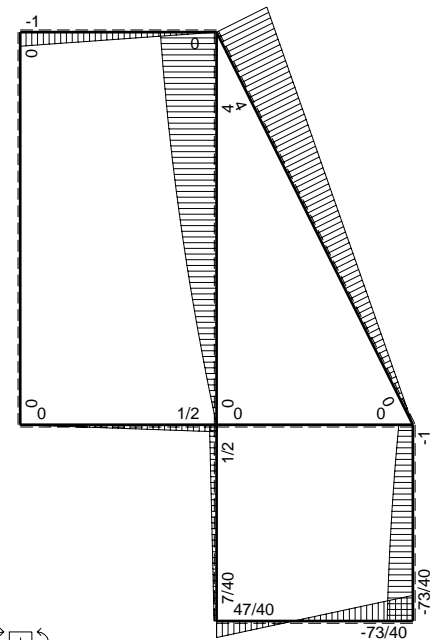

⊕ ⊖ F_b

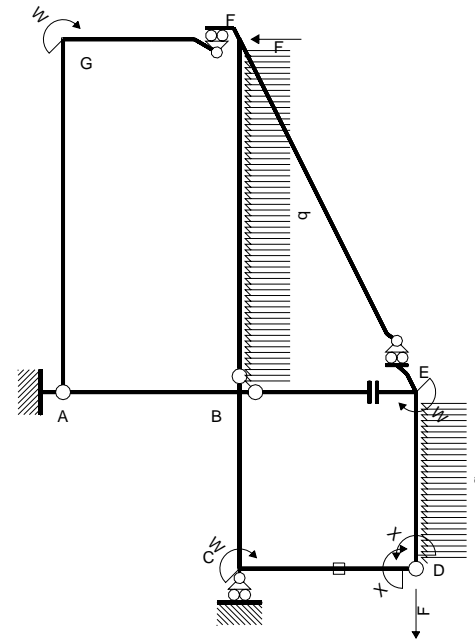

Schema di calcolo iperstatico

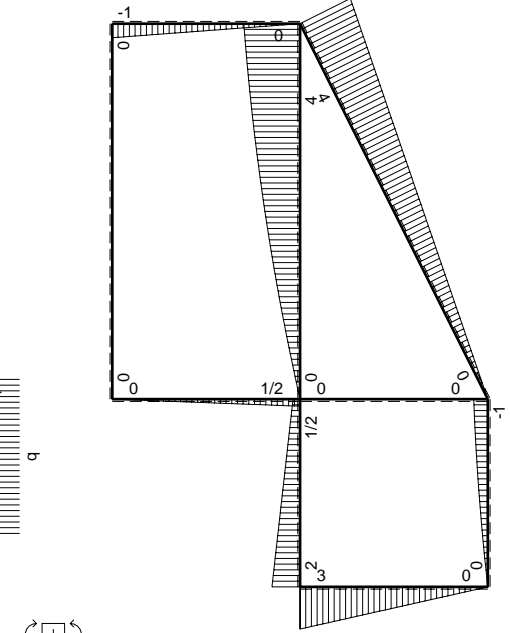

⊕ ⊖ M₀ flessione da carichi assegnati

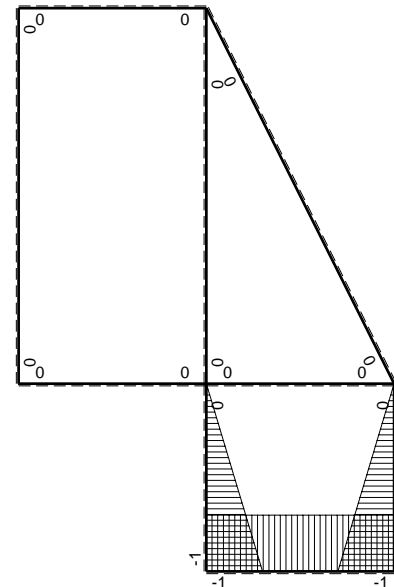

⊕ ⊖ M_x flessione da iperstatica X=1

Quadro contributi PLV per iperstatica X=W_{DE}

→	M _x (x)	M _o (x)	M _x M _o	M _x M _x	∫M _x M _o /EJdx	∫XM _x M _x /EJdx
AB b	0	1/2Fx	0	0	0	0
BA b	0	-1/2Fb+1/2Fx	0	0	0	0
BC b	-x/b	1/2Fb+3/2Fx	-1/2Fx-3/2Fx ² /b	x ² /b ²	-3/4Fb ² /EJ	1/3Xb/EJ
CB b	1-x/b	-2Fb+3/2Fx	-2Fb+7/2Fx-3/2Fx ² /b	1-2x/b+x ² /b ²	-3/4Fb ² /EJ	1/3Xb/EJ
CD b	-1	3Fb-3Fx	-3Fb+3Fx	1	-3/2Fb ² /EJ	Xb/EJ
DC b	1	-3Fx	-3Fx	1	-3/2Fb ² /EJ	Xb/EJ
DE b	-1+x/b	-3/2Fx+1/2qx ²	3/2Fx-2Fx ² /b+1/2qx ³ /b	1-2x/b+x ² /b ²	5/24Fb ² /EJ	1/3Xb/EJ
ED b	x/b	Fb-1/2Fx-1/2qx ²	Fx-1/2Fx ² /b-1/2qx ³ /b	x ² /b ²	5/24Fb ² /EJ	1/3Xb/EJ
EF √5b	0	4√5/5Fx	0	0	0	0
FG b	0	-Fx	0	0	0	0
GF b	0	Fb-Fx	0	0	0	0
GA 2b	0	0	0	0	0	0
AG 2b	0	0	0	0	0	0
FB 2b	0	4Fb-Fx-1/2qx ²	0	0	0	0
BF 2b	0	-3Fx+1/2qx ²	0	0	0	0
BE b	0	0	0	0	0	0
EB b	0	0	0	0	0	0
CD	elongazione asta N _{1CD} ε _{CD} L _{CD}				-Fb ² /EJ	
	totali				-73/24Fb ² /EJ	5/3Xb/EJ
	iperstatica X=W _{DE}				73/40Fb	

Sviluppi di calcolo iperstatica

$$L_{BC}^{xx} = \int_0^b (x^2/b^2) 1/EJ dx = [1/3 x^3/b^2]_0^b 1/EJ = (1/3 b) 1/EJ = 1/3 b/EJ$$

$$L_{CB}^{xx} = \int_0^b (1 - 2x/b + x^2/b^2) 1/EJ dx = [x - x^2/b + 1/3 x^3/b^2]_0^b 1/EJ = (b - b + 1/3 b) 1/EJ = 1/3 b/EJ$$

$$L_{CD}^{xx} = \int_0^b (1) 1/EJ dx = [x]_0^b 1/EJ = (b) 1/EJ = b/EJ$$

$$L_{DC}^{xx} = \int_0^b (1) 1/EJ dx = [x]_0^b 1/EJ = (b) 1/EJ = b/EJ$$

$$L_{DE}^{xx} = \int_0^b (1 - 2x/b + x^2/b^2) 1/EJ dx = [x - x^2/b + 1/3 x^3/b^2]_0^b 1/EJ = (b - b + 1/3 b) 1/EJ = 1/3 b/EJ$$

$$L_{ED}^{xx} = \int_0^b (x^2/b^2) 1/EJ dx = [1/3 x^3/b^2]_0^b 1/EJ = (1/3 b) 1/EJ = 1/3 b/EJ$$

$$L_{BC}^{xo} = \int_0^b (-1/2 x/b - 3/2 x^2/b^2) Fb 1/EJ dx = [-1/4 x^2/b - 1/2 x^3/b^2]_0^b Fb 1/EJ = (-1/4 b - 1/2 b) Fb 1/EJ = -3/4 Fb^2/EJ$$

$$L_{CB}^{xo} = \int_0^b (-2 + 7/2 x/b - 3/2 x^2/b^2) Fb 1/EJ dx = [-2x + 7/4 x^2/b - 1/2 x^3/b^2]_0^b Fb 1/EJ = (-2b + 7/4 b - 1/2 b) Fb 1/EJ = -3/4 Fb^2/EJ$$

$$L_{CD}^{xo} = \int_0^b (-3 + 3x/b) Fb 1/EJ dx + 1 (-1) 1 Fb^2/EJ = [-3x + 3/2 x^2/b]_0^b Fb 1/EJ + 1 (-1) 1 Fb^2/EJ = (-3b + 3/2 b) Fb 1/EJ + 1 (-1) 1 Fb^2/EJ = -5/2 Fb^2/EJ$$

$$L_{DC}^{xo} = \int_0^b (-3x/b) Fb 1/EJ dx + 1 (-1) 1 Fb^2/EJ = [-3/2 x^2/b]_0^b Fb 1/EJ + 1 (-1) 1 Fb^2/EJ = (-3/2 b) Fb 1/EJ + 1 (-1) 1 Fb^2/EJ = -5/2 Fb^2/EJ$$

$$L_{DE}^{xo} = \int_0^b (3/2 x/b - 2x^2/b^2 + 1/2 x^3/b^3) Fb 1/EJ dx = [3/4 x^2/b - 2/3 x^3/b^2 + 1/8 x^4/b^3]_0^b Fb 1/EJ = (3/4 b - 2/3 b + 1/8 b) Fb 1/EJ = 5/24 Fb^2/EJ$$

$$L_{ED}^{xo} = \int_0^b (x/b - 1/2 x^2/b^2 - 1/2 x^3/b^3) Fb 1/EJ dx = [1/2 x^2/b - 1/6 x^3/b^2 - 1/8 x^4/b^3]_0^b Fb 1/EJ = (1/2 b - 1/6 b - 1/8 b) Fb 1/EJ = 5/24 Fb^2/EJ$$

- $H_{FB} = -F$
- $V_D = -F$
- $W_C = -W = -Fb$
- $W_G = -W = -Fb$
- $W_E = -W = -Fb$
- $p_{BC} = -q = -F/b$
- $q_{BE} = -q = -F/b$
- $\epsilon_{BE} = -\alpha T = -b^2 F/EJ$
- $k_C = 4EJ/b^3$
- $EJ_{AB} = EJ$
- $EJ_{BC} = EJ$
- $EJ_{CD} = EJ$
- $EJ_{DE} = EJ$
- $EJ_{EF} = EJ$
- $EJ_{FG} = EJ$
- $EJ_{GA} = EJ$
- $EJ_{FB} = EJ$
- $EJ_{BE} = EJ$

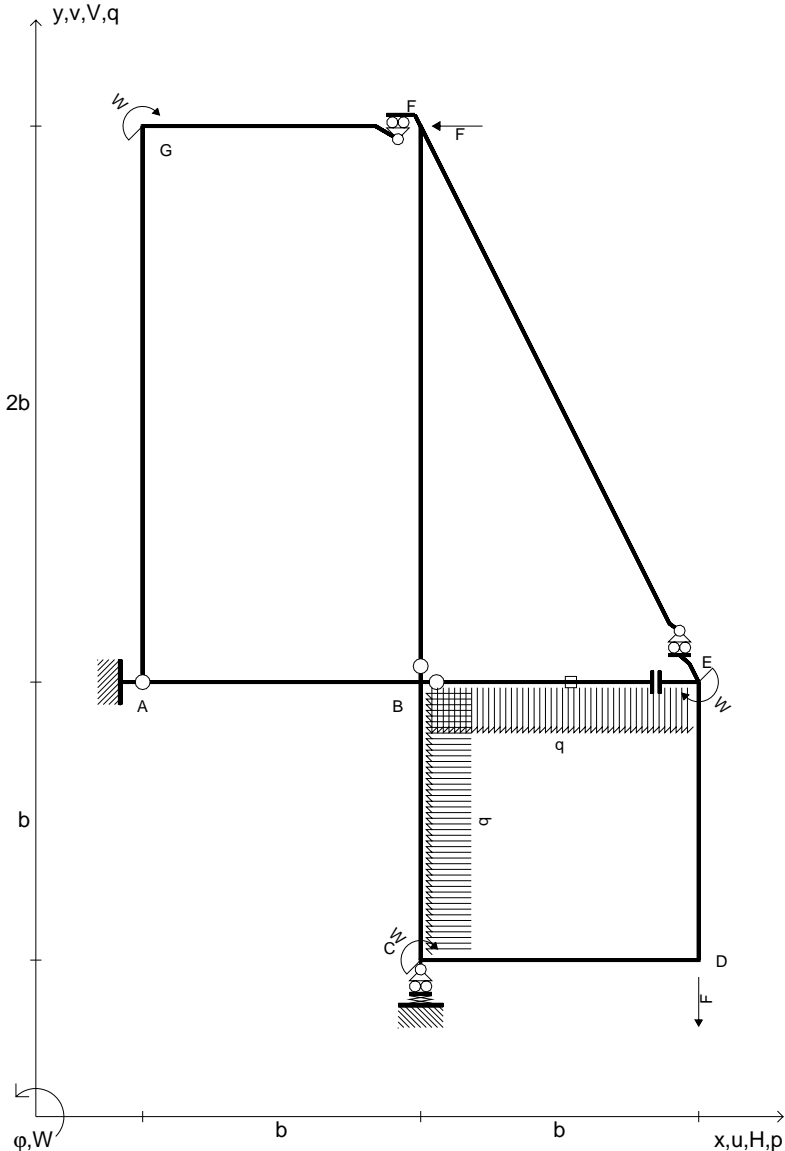

Reazioni iperstatiche in soluzione: $X=H_{BE}$
 Carichi e deformazioni date hanno verso efficace in disegno.
 Calcolare reazioni vincolari della struttura e delle aste.
 Tracciare i diagrammi quotati delle azioni interne nelle aste.
 $J_{YZ} - x_{YZ} - \theta_{YZ}$ riferimento locale asta YZ con origine in Y.
 Elongazione termica specifica ϵ assegnata su asta BE.
 © Adolfo Zavelani Rossi, Politecnico di Milano, vers.27.03.13

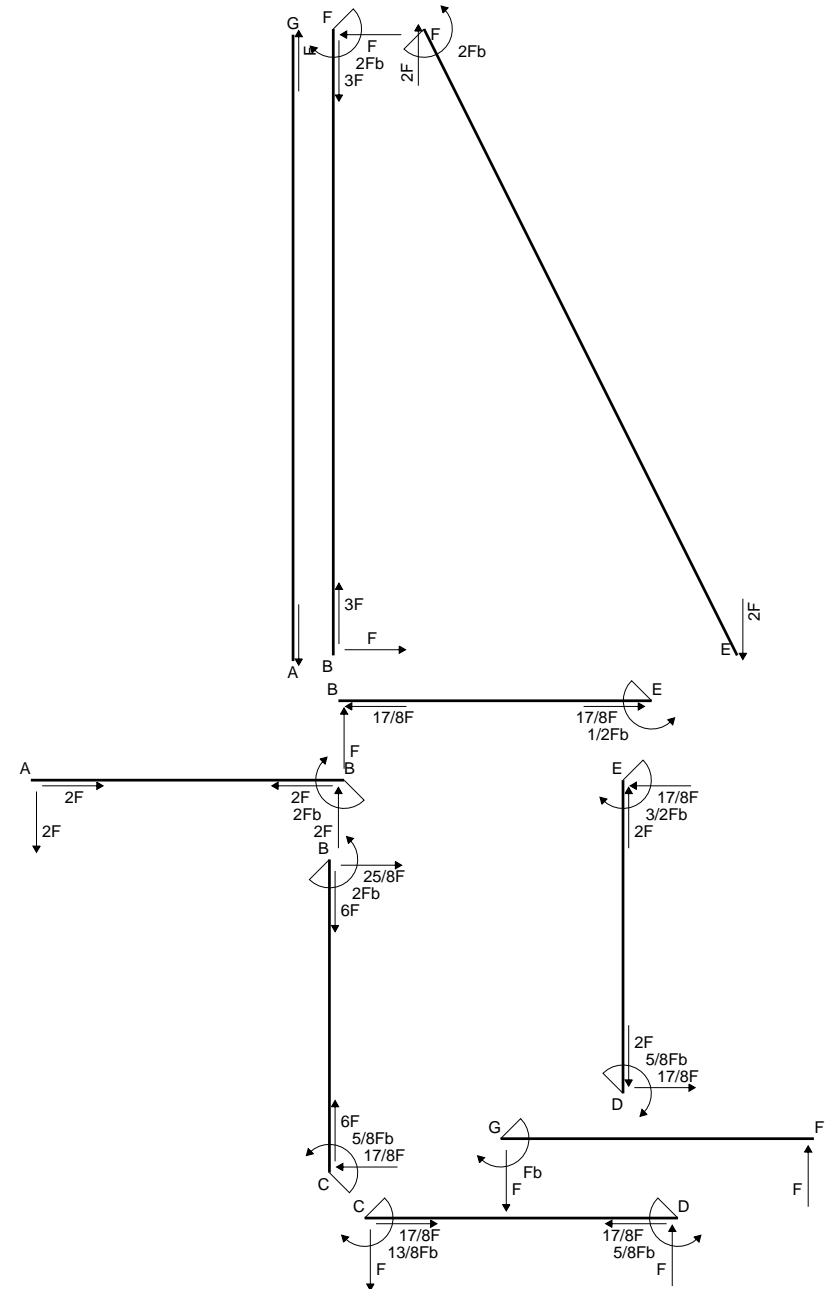

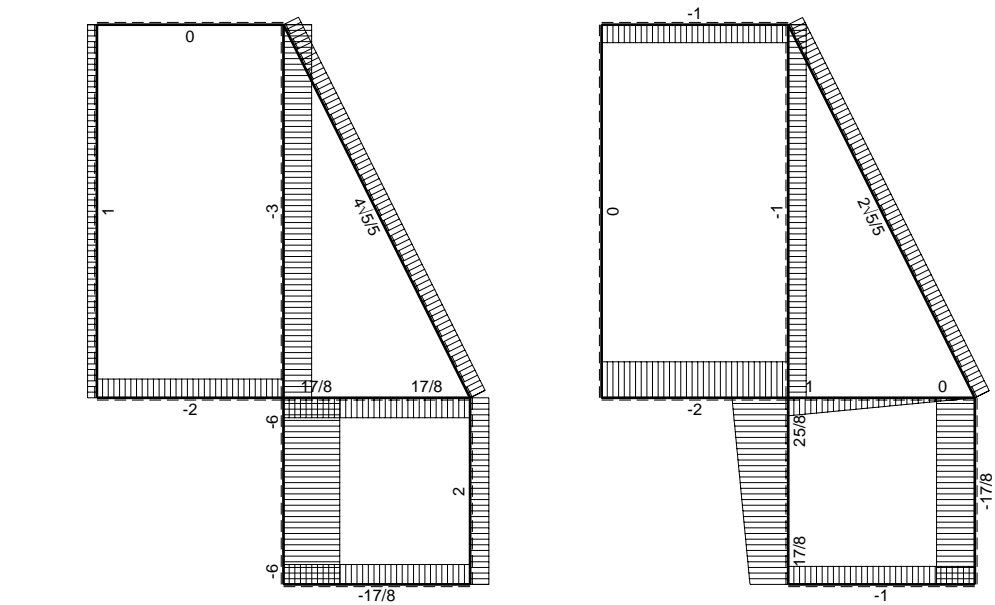

← (+) → F

↑ (+) ↓ F

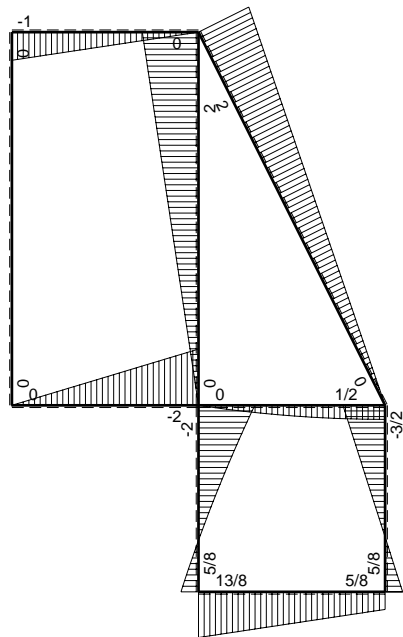

↺ (+) ↻ F_b

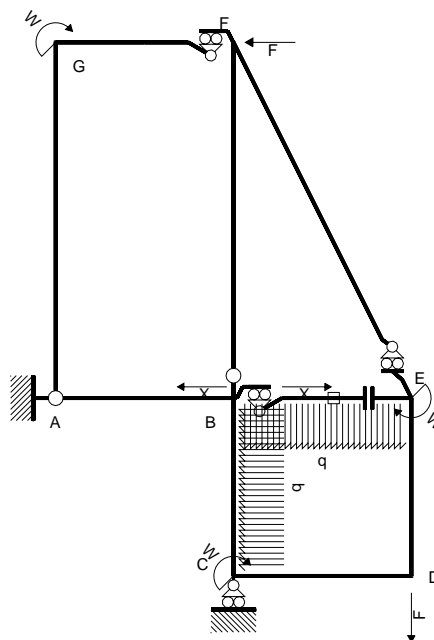

Schema di calcolo iperstatico

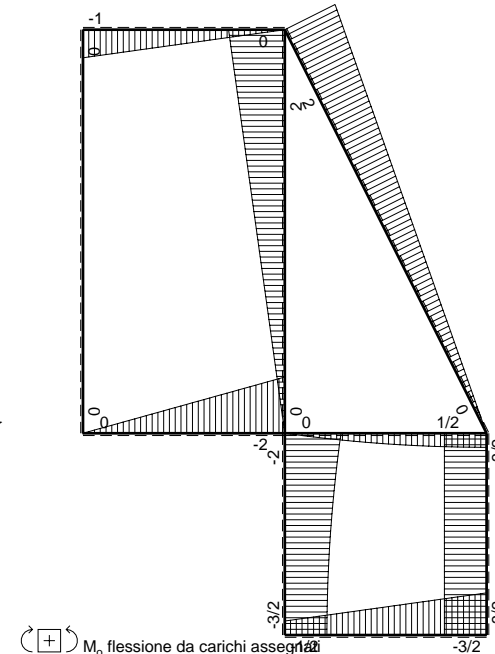

↺ (+) ↻ M₀ flessione da carichi assegnati

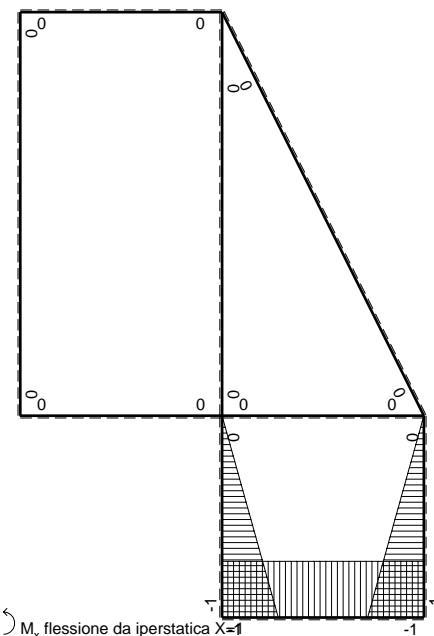

↺ (+) ↻ M_x flessione da iperstatica X=1

Quadro contributi PLV per iperstatica X=H_{BE}

→	M _x (x)	M _o (x)	M _x M _o	M _x M _x	∫M _x M _o /EJdx	∫XM _x M _x /EJdx
AB b	0	-2Fx	0	0	0	0
BA b	0	2Fb-2Fx	0	0	0	0
BC b	-x	-2Fb+Fx-1/2qx ²	2Fbx-Fx ² +1/2qx ³	x ²	19/24Fb ³ /EJ	1/3Xb ³ /EJ
CB b	b-x	3/2Fb+1/2qx ²	3/2Fb ² -3/2Fbx+1/2Fx ² -1/2qx ³	b ² -2bx+x ²		
CD b	-b	-1/2Fb-Fx	1/2Fb ² +Fbx	b ²	Fb ³ /EJ	Xb ³ /EJ
DC b	b	3/2Fb-Fx	3/2Fb ² -Fbx	b ²		
DE b	-b+x	-3/2Fb	3/2Fb ² -3/2Fbx	b ² -2bx+x ²	3/4Fb ³ /EJ	1/3Xb ³ /EJ
ED b	x	3/2Fb	3/2Fbx	x ²		
EF √5b	0	2√5/5Fx	0	0	0	0
FG b	0	-Fx	0	0	0	0
GF b	0	Fb-Fx	0	0	0	0
GA 2b	0	0	0	0	0	0
AG 2b	0	0	0	0	0	0
FB 2b	0	2Fb-Fx	0	0	0	0
BF 2b	0	-Fx	0	0	0	0
BE b	0	Fx-1/2qx ²	0	0	0	0
EB b	0	-1/2Fb+1/2qx ²	0	0	0	0
BE	elongazione asta N _{1BE} ε _{BE} L _{BE}				Fb ³ /EJ	
	totali				85/24Fb ³ /EJ	5/3Xb ³ /EJ
	iperstatica X=H _{BE}				-17/8F	

Sviluppi di calcolo iperstatica

$$L_{BC}^{XX} = \int_0^b (x^2/b^2) b^2 1/EJ dx = [1/3 x^3/b^2]_0^b b^2 1/EJ$$

$$= (1/3 b) b^2 1/EJ = 1/3 b^3/EJ$$

$$L_{CB}^{XX} = \int_0^b (1 - 2x/b + x^2/b^2) b^2 1/EJ dx = [x - x^2/b + 1/3 x^3/b^2]_0^b b^2 1/EJ$$

$$= (b - b + 1/3 b) b^2 1/EJ = 1/3 b^3/EJ$$

$$L_{CD}^{XX} = \int_0^b (1) b^2 1/EJ dx = [x]_0^b b^2 1/EJ$$

$$= (b) b^2 1/EJ = b^3/EJ$$

$$L_{DC}^{XX} = \int_0^b (1) b^2 1/EJ dx = [x]_0^b b^2 1/EJ$$

$$= (b) b^2 1/EJ = b^3/EJ$$

$$L_{DE}^{XX} = \int_0^b (1 - 2x/b + x^2/b^2) b^2 1/EJ dx = [x - x^2/b + 1/3 x^3/b^2]_0^b b^2 1/EJ$$

$$= (b - b + 1/3 b) b^2 1/EJ = 1/3 b^3/EJ$$

$$L_{ED}^{XX} = \int_0^b (x^2/b^2) b^2 1/EJ dx = [1/3 x^3/b^2]_0^b b^2 1/EJ$$

$$= (1/3 b) b^2 1/EJ = 1/3 b^3/EJ$$

$$L_{BC}^{Xo} = \int_0^b (2x/b - x^2/b^2 + 1/2 x^3/b^3) Fb^2 1/EJ dx = [x^2/b - 1/3 x^3/b^2 + 1/8 x^4/b^3]_0^b Fb^2 1/EJ$$

$$= (b - 1/3 b + 1/8 b) Fb^2 1/EJ = 19/24 Fb^3/EJ$$

$$L_{CB}^{Xo} = \int_0^b (3/2 - 3/2 x/b + 1/2 x^2/b^2 - 1/2 x^3/b^3) Fb^2 1/EJ dx$$

$$= [3/2 x - 3/4 x^2/b + 1/6 x^3/b^2 - 1/8 x^4/b^3]_0^b Fb^2 1/EJ$$

$$= (3/2 b - 3/4 b + 1/6 b - 1/8 b) Fb^2 1/EJ = 19/24 Fb^3/EJ$$

$$L_{CD}^{Xo} = \int_0^b (1/2 + x/b) Fb^2 1/EJ dx = [1/2 x + 1/2 x^2/b]_0^b Fb^2 1/EJ$$

$$= (1/2 b + 1/2 b) Fb^2 1/EJ = Fb^3/EJ$$

$$L_{DC}^{Xo} = \int_0^b (3/2 - x/b) Fb^2 1/EJ dx = [3/2 x - 1/2 x^2/b]_0^b Fb^2 1/EJ$$

$$= (3/2 b - 1/2 b) Fb^2 1/EJ = Fb^3/EJ$$

$$L_{DE}^{Xo} = \int_0^b (3/2 - 3/2 x/b) Fb^2 1/EJ dx = [3/2 x - 3/4 x^2/b]_0^b Fb^2 1/EJ$$

$$= (3/2 b - 3/4 b) Fb^2 1/EJ = 3/4 Fb^3/EJ$$

$$L_{ED}^{Xo} = \int_0^b (3/2 x/b) Fb^2 1/EJ dx = [3/4 x^2/b]_0^b Fb^2 1/EJ$$

$$= (3/4 b) Fb^2 1/EJ = 3/4 Fb^3/EJ$$

- $H_{FB} = -F$
- $V_D = -F$
- $W_C = -W = -Fb$
- $W_G = -W = -Fb$
- $W_E = -W = -Fb$
- $p_{BC} = -q = -F/b$
- $p_{DE} = -q = -F/b$
- $\epsilon_{BE} = -\alpha T = -b^2 F/EJ$
- $k_C = 4EJ/b^3$
- $EJ_{AB} = EJ$
- $EJ_{BC} = EJ$
- $EJ_{CD} = EJ$
- $EJ_{DE} = EJ$
- $EJ_{EF} = EJ$
- $EJ_{FG} = EJ$
- $EJ_{GA} = EJ$
- $EJ_{FB} = EJ$
- $EJ_{BE} = EJ$

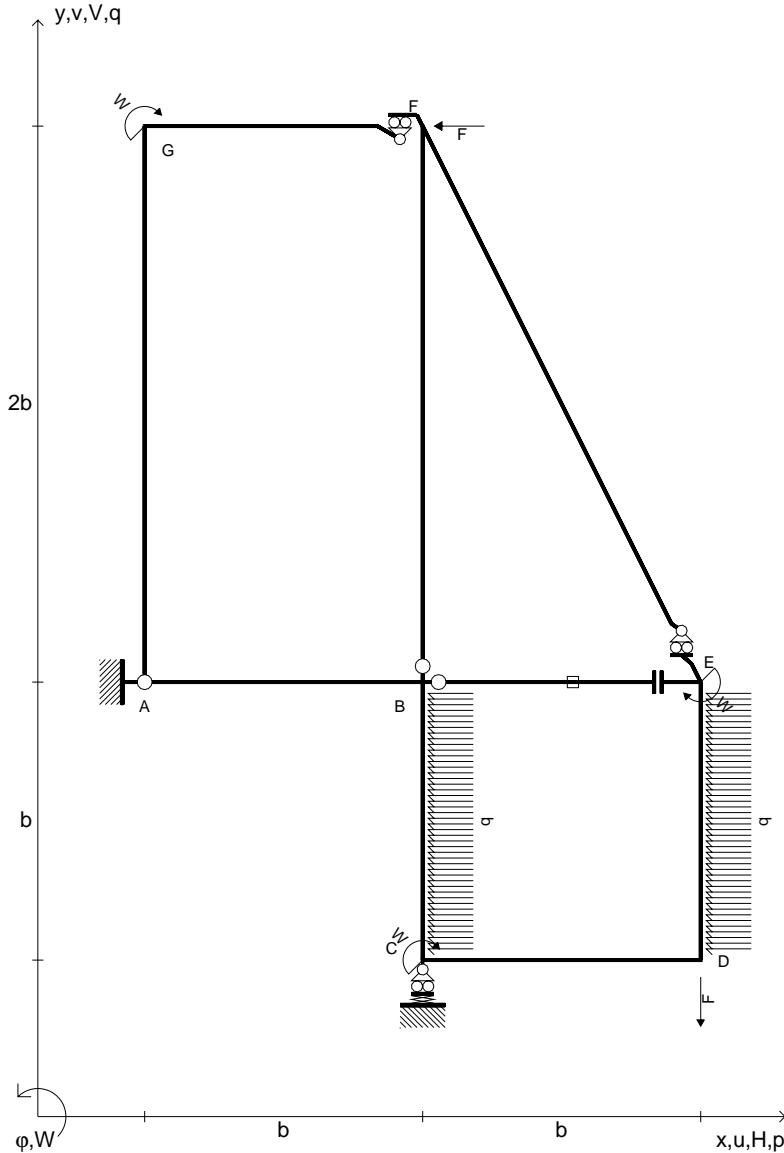

Reazioni iperstatiche in soluzione: $X=W_{CD}$
 Carichi e deformazioni date hanno verso efficace in disegno.
 Calcolare reazioni vincolari della struttura e delle aste.
 Tracciare i diagrammi quotati delle azioni interne nelle aste.
 $J_{YZ} - x_{YZ} - \theta_{YZ}$ riferimento locale asta YZ con origine in Y.
 Elongazione termica specifica ϵ assegnata su asta BE.
 @ Adolfo Zavelani Rossi, Politecnico di Milano, vers.27.03.13

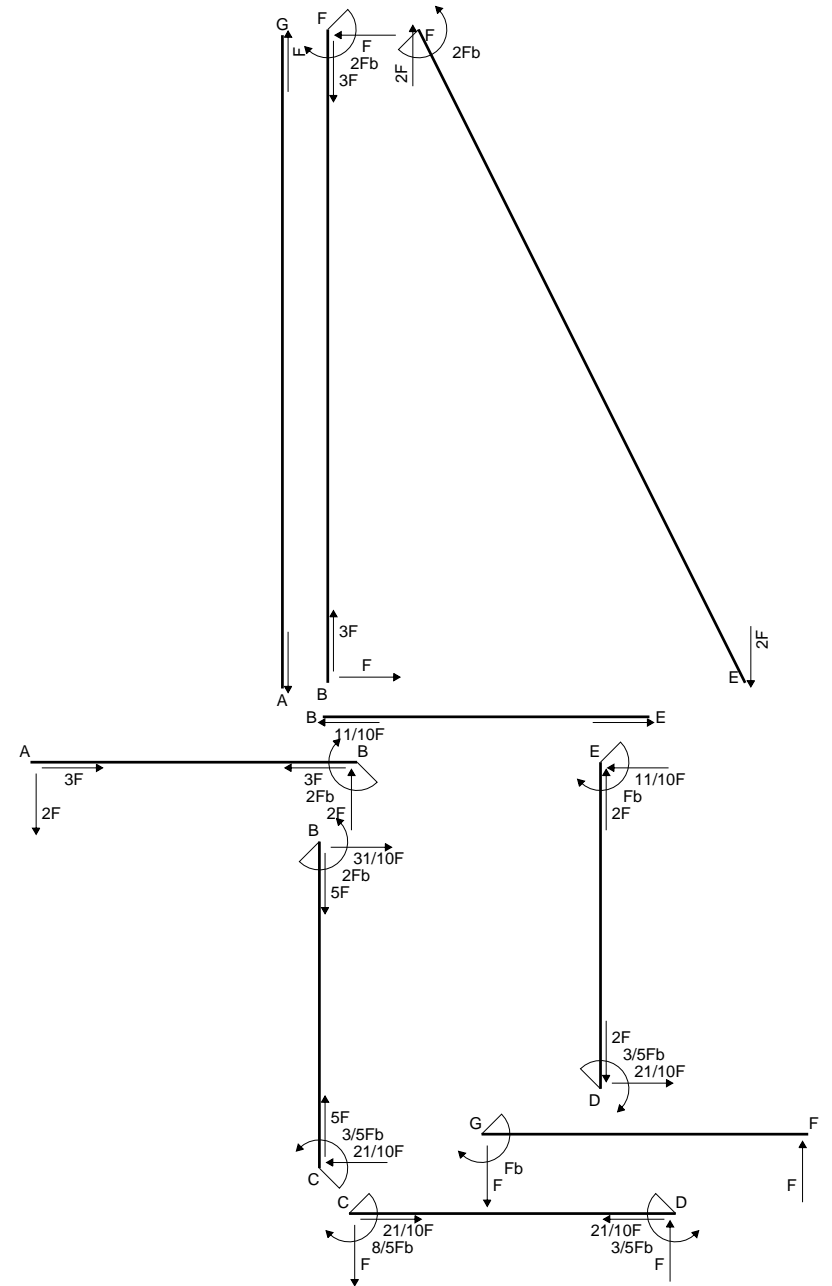

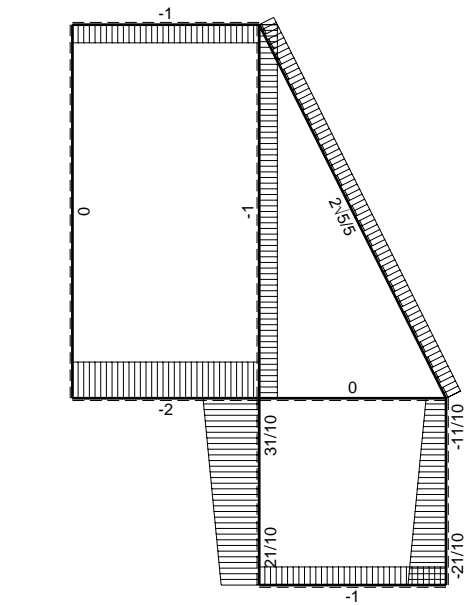
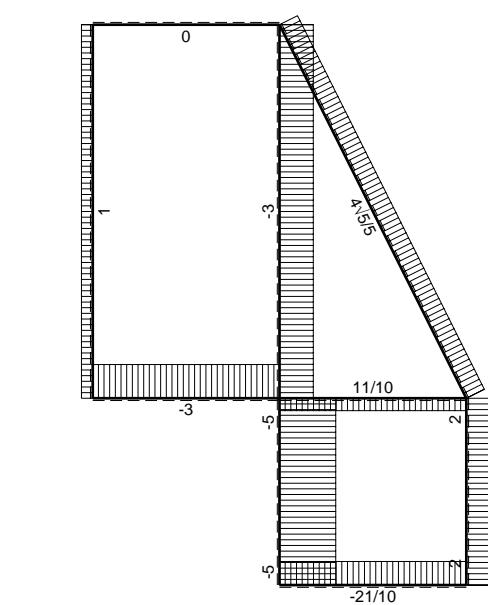

← (+) → F

↑ (+) ↓ F

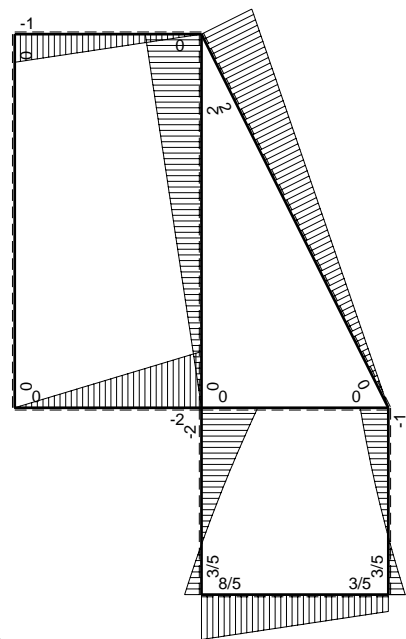

⤵ (+) ⤴ F_b

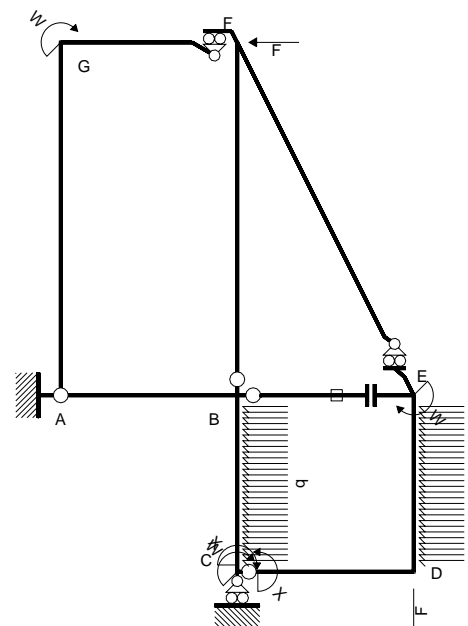

Schema di calcolo iperstatico

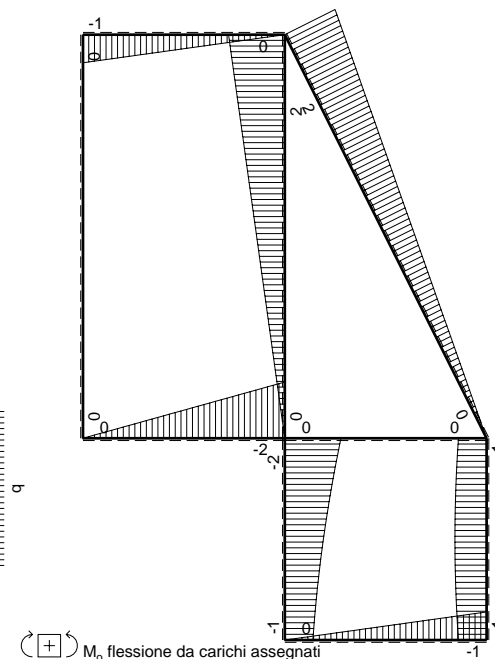

⤵ (+) ⤴ M_o flessione da carichi assegnati

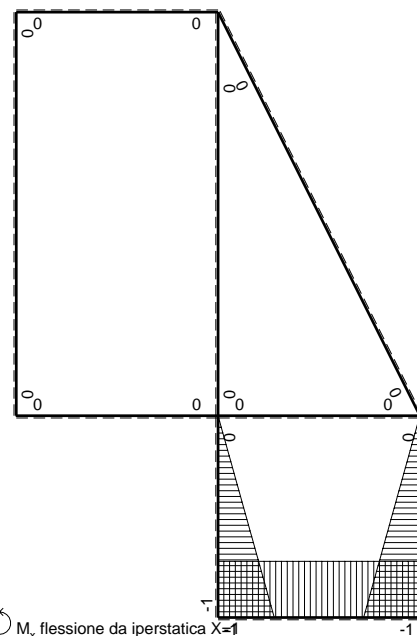

⤵ (+) ⤴ M_x flessione da iperstatica X=1

Quadro contributi PLV per iperstatica X=W_{CD}

→	M _x (x)	M _o (x)	M _x M _o	M _x M _x	∫M _x M _o /EJdx	∫xM _x M _x /EJdx
AB b	0	-2Fx	0	0	0	0
BA b	0	2Fb-2Fx	0	0	0	0
BC b	-x/b	-2Fb+3/2Fx-1/2qx ²	2Fx-3/2Fx ² /b+1/2qx ³ /b	x ² /b ²	5/8Fb ² /EJ	1/3Xb/EJ
CB b	1-x/b	Fb+1/2Fx+1/2qx ²	Fb-1/2Fx-1/2qx ³ /b	1-2x/b+x ² /b ²	1/2Fb ² /EJ	Xb/EJ
CD b	-1	-Fx	Fx	1	1/2Fb ² /EJ	Xb/EJ
DC b	1	Fb-Fx	Fb-Fx	1	1/2Fb ² /EJ	Xb/EJ
DE b	-1+x/b	-Fb-1/2Fx+1/2qx ²	Fb-1/2Fx-Fx ² /b+1/2qx ³ /b	1-2x/b+x ² /b ²	13/24Fb ² /EJ	1/3Xb/EJ
ED b	x/b	Fb+1/2Fx-1/2qx ²	Fx+1/2Fx ² /b-1/2qx ³ /b	x ² /b ²	13/24Fb ² /EJ	1/3Xb/EJ
EF √5b	0	2√5/5Fx	0	0	0	0
FG b	0	-Fx	0	0	0	0
GF b	0	Fb-Fx	0	0	0	0
GA 2b	0	0	0	0	0	0
AG 2b	0	0	0	0	0	0
FB 2b	0	2Fb-Fx	0	0	0	0
BF 2b	0	-Fx	0	0	0	0
BE b	0	0	0	0	0	0
EB b	0	0	0	0	0	0
BE	elongazione asta N _{1BE} ε _{BE} L _{BE}				Fb ² /EJ	
	totali				8/3Fb ² /EJ	5/3Xb/EJ
	iperstatica X=W _{CD}				-8/5Fb	

Sviluppi di calcolo iperstatica

$$L_{BC}^{xx} = \int_0^b (x^2/b^2) 1/EJ dx = [1/3 x^3/b^2]_0^b 1/EJ = (1/3 b) 1/EJ = 1/3 b/EJ$$

$$L_{CB}^{xx} = \int_0^b (1 - 2x/b + x^2/b^2) 1/EJ dx = [x - x^2/b + 1/3 x^3/b^2]_0^b 1/EJ = (b - b + 1/3 b) 1/EJ = 1/3 b/EJ$$

$$L_{CD}^{xx} = \int_0^b (1) 1/EJ dx = [x]_0^b 1/EJ = (b) 1/EJ = b/EJ$$

$$L_{DC}^{xx} = \int_0^b (1) 1/EJ dx = [x]_0^b 1/EJ = (b) 1/EJ = b/EJ$$

$$L_{DE}^{xx} = \int_0^b (-2x/b + x^2/b^2) 1/EJ dx = [x - x^2/b + 1/3 x^3/b^2]_0^b 1/EJ = (b - b + 1/3 b) 1/EJ = 1/3 b/EJ$$

$$L_{ED}^{xx} = \int_0^b (x^2/b^2) 1/EJ dx = [1/3 x^3/b^2]_0^b 1/EJ = (1/3 b) 1/EJ = 1/3 b/EJ$$

$$L_{BC}^{xo} = \int_0^b (2x/b - 3/2 x^2/b^2 + 1/2 x^3/b^3) Fb 1/EJ dx = [x^2/b - 1/2 x^3/b^2 + 1/8 x^4/b^3]_0^b Fb 1/EJ = (b - 1/2 b + 1/8 b) Fb 1/EJ = 5/8 Fb^2/EJ$$

$$L_{CB}^{xo} = \int_0^b (1 - 1/2 x/b - 1/2 x^3/b^3) Fb 1/EJ dx = [x - 1/4 x^2/b - 1/8 x^4/b^3]_0^b Fb 1/EJ = (b - 1/4 b - 1/8 b) Fb 1/EJ = 5/8 Fb^2/EJ$$

$$L_{CD}^{xo} = \int_0^b (x/b) Fb 1/EJ dx = [1/2 x^2/b]_0^b Fb 1/EJ = (1/2 b) Fb 1/EJ = 1/2 Fb^2/EJ$$

$$L_{DC}^{xo} = \int_0^b (1 - x/b) Fb 1/EJ dx = [x - 1/2 x^2/b]_0^b Fb 1/EJ = (b - 1/2 b) Fb 1/EJ = 1/2 Fb^2/EJ$$

$$L_{DE}^{xo} = \int_0^b (1 - 1/2 x/b - x^2/b^2 + 1/2 x^3/b^3) Fb 1/EJ dx = [x - 1/4 x^2/b - 1/3 x^3/b^2 + 1/8 x^4/b^3]_0^b Fb 1/EJ = (b - 1/4 b - 1/3 b + 1/8 b) Fb 1/EJ = 13/24 Fb^2/EJ$$

$$L_{ED}^{xo} = \int_0^b (x/b + 1/2 x^2/b^2 - 1/2 x^3/b^3) Fb 1/EJ dx = [1/2 x^2/b + 1/6 x^3/b^2 - 1/8 x^4/b^3]_0^b Fb 1/EJ = (1/2 b + 1/6 b - 1/8 b) Fb 1/EJ = 13/24 Fb^2/EJ$$

- $H_{FB} = -F$
- $V_D = -F$
- $W_C = -W = -Fb$
- $W_G = -W = -Fb$
- $W_E = -W = -Fb$
- $p_{BC} = -q = -F/b$
- $p_{DE} = -q = -F/b$
- $\epsilon_{CD} = -\alpha T = -b^2 F/EJ$
- $k_C = 4EJ/b^3$
- $EJ_{AB} = EJ$
- $EJ_{BC} = EJ$
- $EJ_{CD} = EJ$
- $EJ_{DE} = EJ$
- $EJ_{EF} = EJ$
- $EJ_{FG} = EJ$
- $EJ_{GA} = EJ$
- $EJ_{FB} = EJ$
- $EJ_{BE} = EJ$

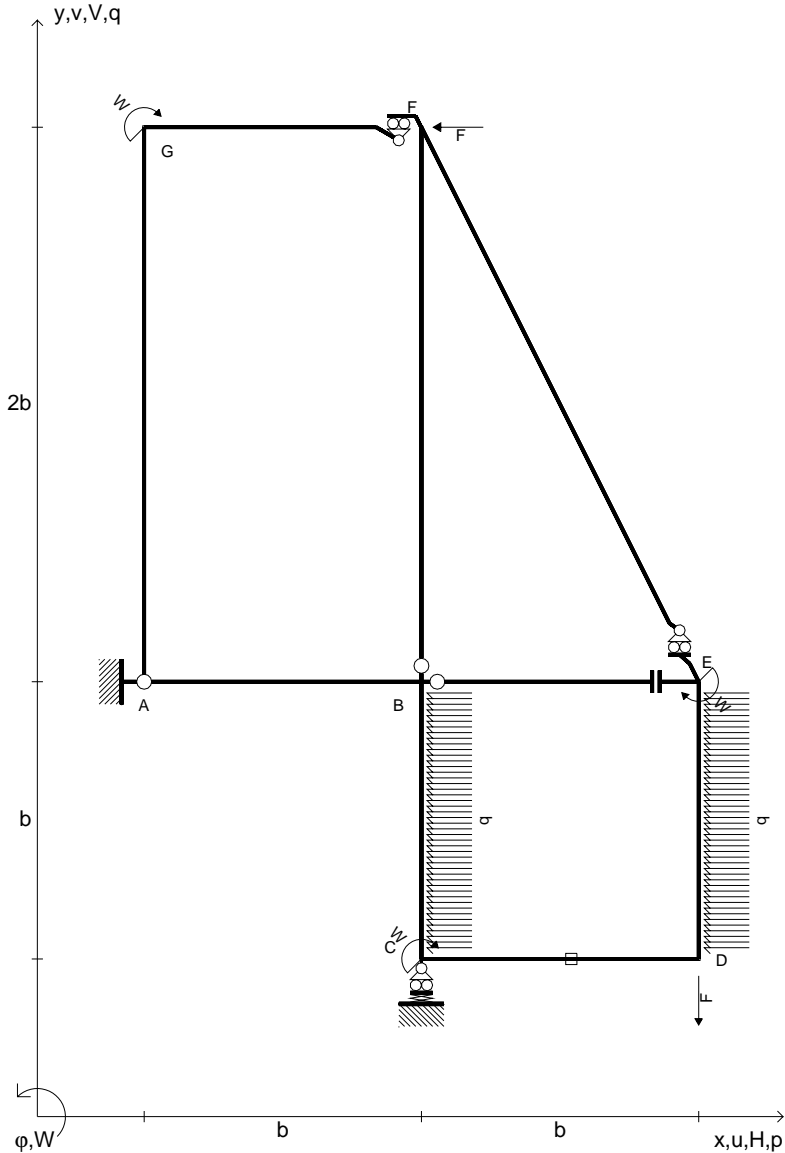

Reazioni iperstatiche in soluzione: $X=H_{BE}$
 Carichi e deformazioni date hanno verso efficace in disegno.
 Calcolare reazioni vincolari della struttura e delle aste.
 Tracciare i diagrammi quotati delle azioni interne nelle aste.
 $J_{YZ} - x_{YZ} - \theta_{YZ}$ riferimento locale asta YZ con origine in Y.
 Elongazione termica specifica ϵ assegnata su asta CD.
 © Adolfo Zavelani Rossi, Politecnico di Milano, vers.27.03.13

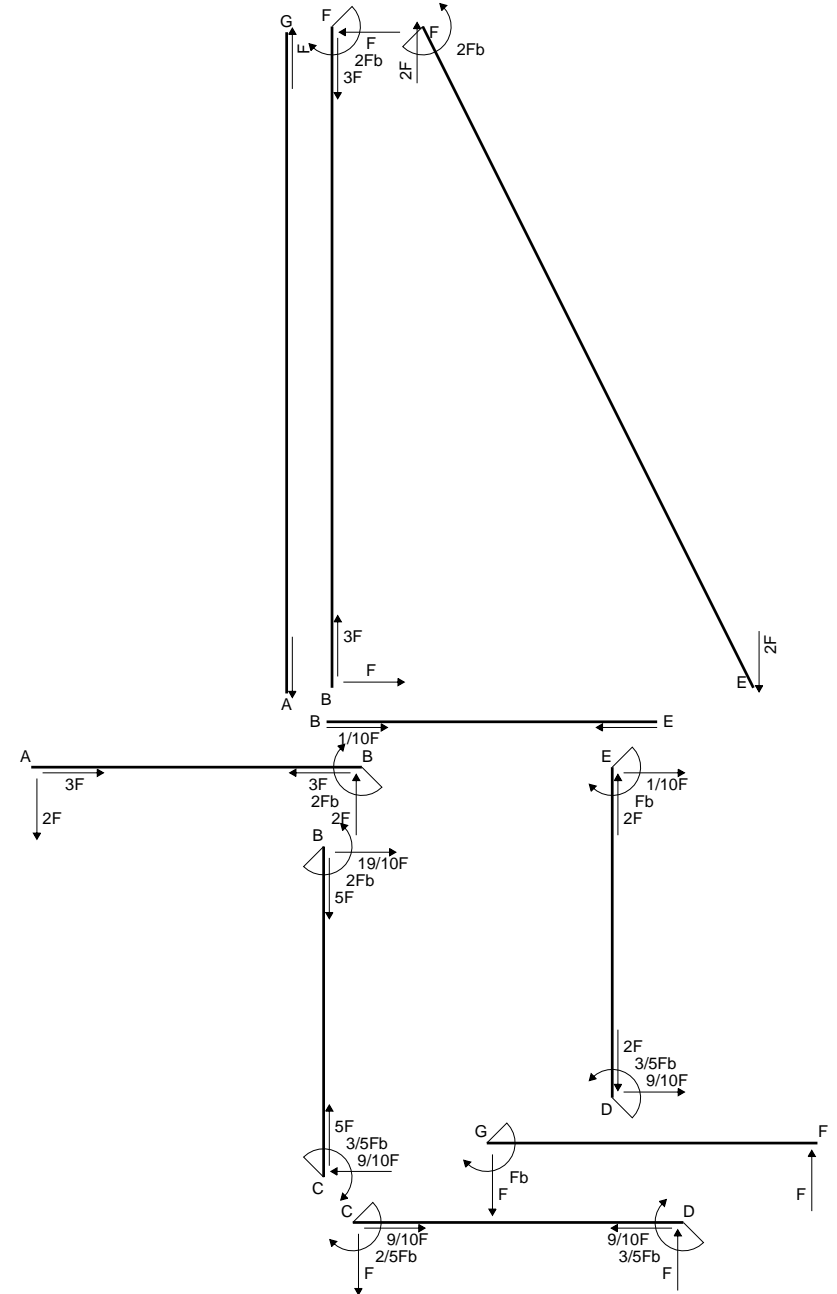

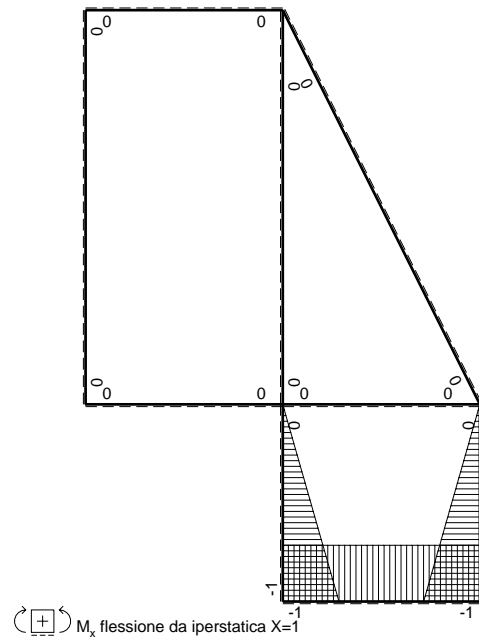
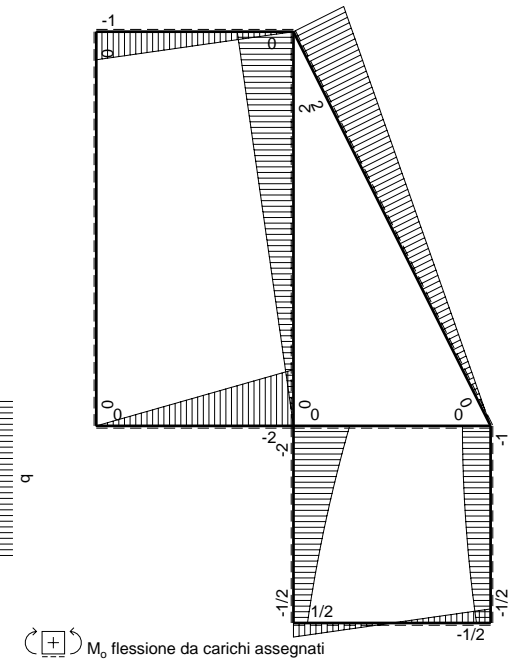
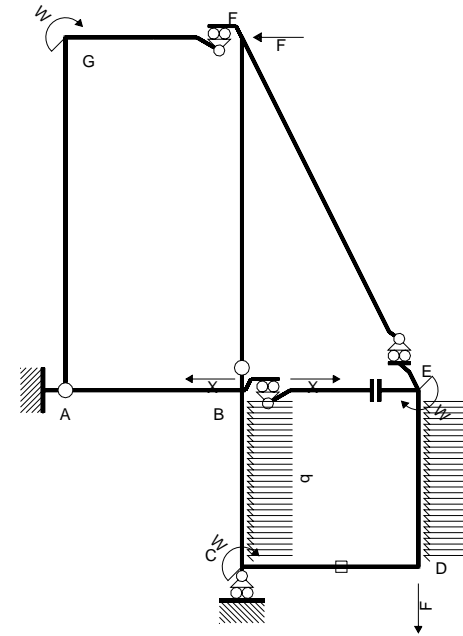
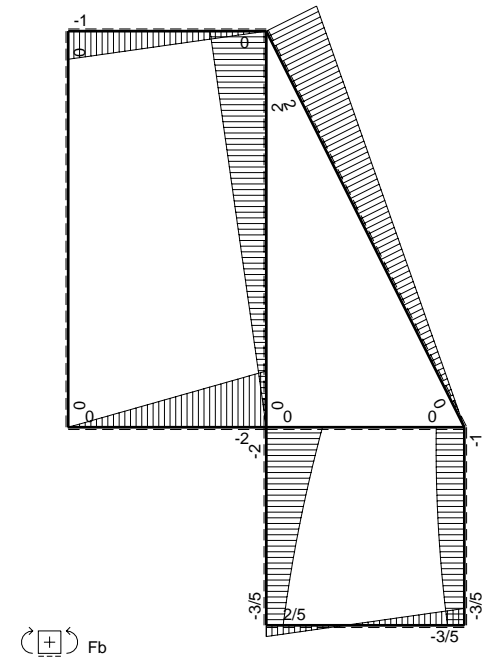
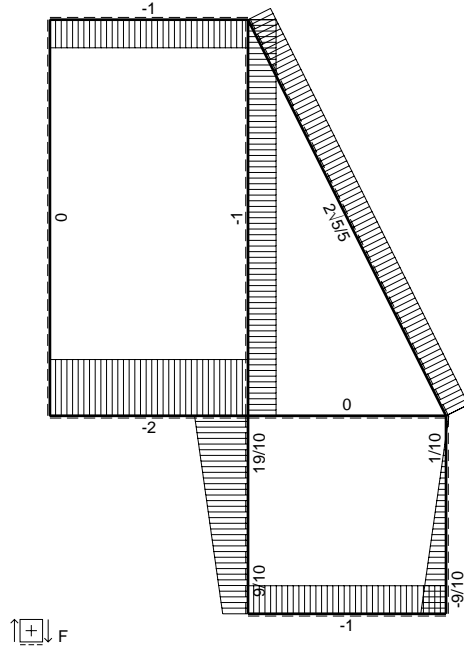
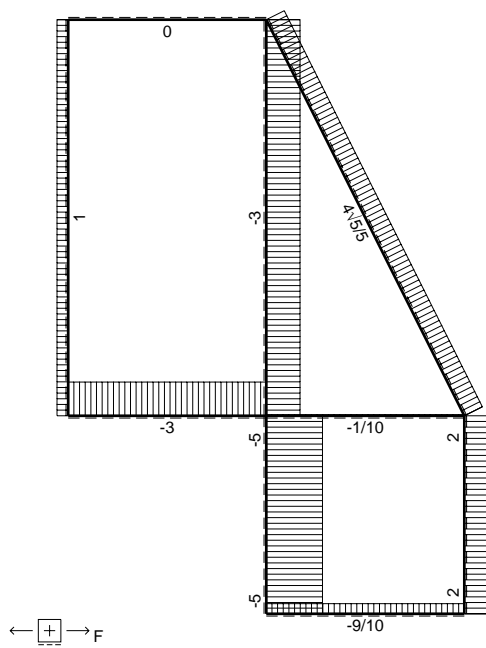

Quadro contributi PLV per iperstatica X=H_{BE}

→	M _x (x)	M _o (x)	M _x M _o	M _x M _x	∫M _x M _o /EJdx	∫XM _x M _x /EJdx
AB b	0	-2Fx	0	0	0	0
BA b	0	2Fb-2Fx	0	0	0	0
BC b	-x	-2Fb+2Fx-1/2qx ²	2Fbx-2Fx ² +1/2qx ³	x ²	11/24Fb ³ /EJ	1/3Xb ³ /EJ
CB b	b-x	1/2Fb+Fx+1/2qx ²	1/2Fb ² +1/2Fbx-1/2Fx ² -1/2qx ³	b ² -2bx+x ²		
CD b	-b	1/2Fb-Fx	-1/2Fb ² +Fbx	b ²	0	Xb ³ /EJ
DC b	b	1/2Fb-Fx	1/2Fb ² -Fbx	b ²		
DE b	-b+x	-1/2Fb-Fx+1/2qx ²	1/2Fb ² +1/2Fbx-3/2Fx ² +1/2qx ³	b ² -2bx+x ²	3/8Fb ³ /EJ	1/3Xb ³ /EJ
ED b	x	Fb-1/2qx ²	Fbx-1/2qx ³	x ²		
EF √5b	0	2√5/5Fx	0	0	0	0
FG b	0	-Fx	0	0	0	0
GF b	0	Fb-Fx	0	0	0	0
GA 2b	0	0	0	0	0	0
AG 2b	0	0	0	0	0	0
FB 2b	0	2Fb-Fx	0	0	0	0
BF 2b	0	-Fx	0	0	0	0
BE b	0	0	0	0	0	0
EB b	0	0	0	0	0	0
CD	elongazione asta N _{1CD} ε _{CD} L _{CD}				-Fb ³ /EJ	
	totali				-1/6Fb ³ /EJ	5/3Xb ³ /EJ
	iperstatica X=H _{BE}				1/10F	

Sviluppi di calcolo iperstatica

$$L_{BC}^{XX} = \int_0^b (x^2/b^2) b^2 1/EJ dx = [1/3 x^3/b^2]_0^b b^2 1/EJ$$

$$= (1/3 b) b^2 1/EJ = 1/3 b^3/EJ$$

$$L_{CB}^{XX} = \int_0^b (1 - 2x/b + x^2/b^2) b^2 1/EJ dx = [x - x^2/b + 1/3 x^3/b^2]_0^b b^2 1/EJ$$

$$= (b - b + 1/3 b) b^2 1/EJ = 1/3 b^3/EJ$$

$$L_{CD}^{XX} = \int_0^b (1) b^2 1/EJ dx = [x]_0^b b^2 1/EJ$$

$$= (b) b^2 1/EJ = b^3/EJ$$

$$L_{DC}^{XX} = \int_0^b (1) b^2 1/EJ dx = [x]_0^b b^2 1/EJ$$

$$= (b) b^2 1/EJ = b^3/EJ$$

$$L_{DE}^{XX} = \int_0^b (1 - 2x/b + x^2/b^2) b^2 1/EJ dx = [x - x^2/b + 1/3 x^3/b^2]_0^b b^2 1/EJ$$

$$= (b - b + 1/3 b) b^2 1/EJ = 1/3 b^3/EJ$$

$$L_{ED}^{XX} = \int_0^b (x^2/b^2) b^2 1/EJ dx = [1/3 x^3/b^2]_0^b b^2 1/EJ$$

$$= (1/3 b) b^2 1/EJ = 1/3 b^3/EJ$$

$$L_{BC}^{Xo} = \int_0^b (2x/b - 2x^2/b^2 + 1/2 x^3/b^3) Fb^2 1/EJ dx = [x^2/b - 2/3 x^3/b^2 + 1/8 x^4/b^3]_0^b Fb^2 1/EJ$$

$$= (b - 2/3 b + 1/8 b) Fb^2 1/EJ = 11/24 Fb^3/EJ$$

$$L_{CB}^{Xo} = \int_0^b (1/2 + 1/2 x/b - 1/2 x^2/b^2 - 1/2 x^3/b^3) Fb^2 1/EJ dx$$

$$= [1/2 x + 1/4 x^2/b - 1/6 x^3/b^2 - 1/8 x^4/b^3]_0^b Fb^2 1/EJ$$

$$= (1/2 b + 1/4 b - 1/6 b - 1/8 b) Fb^2 1/EJ = 11/24 Fb^3/EJ$$

$$L_{CD}^{Xo} = \int_0^b (-1/2 + x/b) Fb^2 1/EJ dx + 1 (-1) 1 Fb^3/EJ$$

$$= [-1/2 x + 1/2 x^2/b]_0^b Fb^2 1/EJ + 1 (-1) 1 Fb^3/EJ$$

$$= (-1/2 b + 1/2 b) Fb^2 1/EJ + 1 (-1) 1 Fb^3/EJ = - Fb^3/EJ$$

$$L_{DC}^{Xo} = \int_0^b (1/2 - x/b) Fb^2 1/EJ dx + 1 (-1) 1 Fb^3/EJ = [1/2 x - 1/2 x^2/b]_0^b Fb^2 1/EJ + 1 (-1) 1 Fb^3/EJ$$

$$= (1/2 b - 1/2 b) Fb^2 1/EJ + 1 (-1) 1 Fb^3/EJ = - Fb^3/EJ$$

$$L_{DE}^{Xo} = \int_0^b (1/2 + 1/2 x/b - 3/2 x^2/b^2 + 1/2 x^3/b^3) Fb^2 1/EJ dx$$

$$= [1/2 x + 1/4 x^2/b - 1/2 x^3/b^2 + 1/8 x^4/b^3]_0^b Fb^2 1/EJ$$

$$= (1/2 b + 1/4 b - 1/2 b + 1/8 b) Fb^2 1/EJ = 3/8 Fb^3/EJ$$

$$L_{ED}^{Xo} = \int_0^b (x/b - 1/2 x^3/b^3) Fb^2 1/EJ dx = [1/2 x^2/b - 1/8 x^4/b^3]_0^b Fb^2 1/EJ$$

$$= (1/2 b - 1/8 b) Fb^2 1/EJ = 3/8 Fb^3/EJ$$

- $H_{FB} = -F$
- $V_D = -F$
- $W_C = -W = -Fb$
- $W_G = -W = -Fb$
- $W_A = -W = -Fb$
- $q_{BE} = -q = -F/b$
- $p_{GA} = -q = -F/b$
- $\epsilon_{CD} = -\alpha T = -b^2 F/EJ$
- $k_C = 4EJ/b^3$
- $EJ_{AB} = EJ$
- $EJ_{BC} = EJ$
- $EJ_{CD} = EJ$
- $EJ_{DE} = EJ$
- $EJ_{EF} = EJ$
- $EJ_{FG} = EJ$
- $EJ_{GA} = EJ$
- $EJ_{FB} = EJ$
- $EJ_{BE} = EJ$

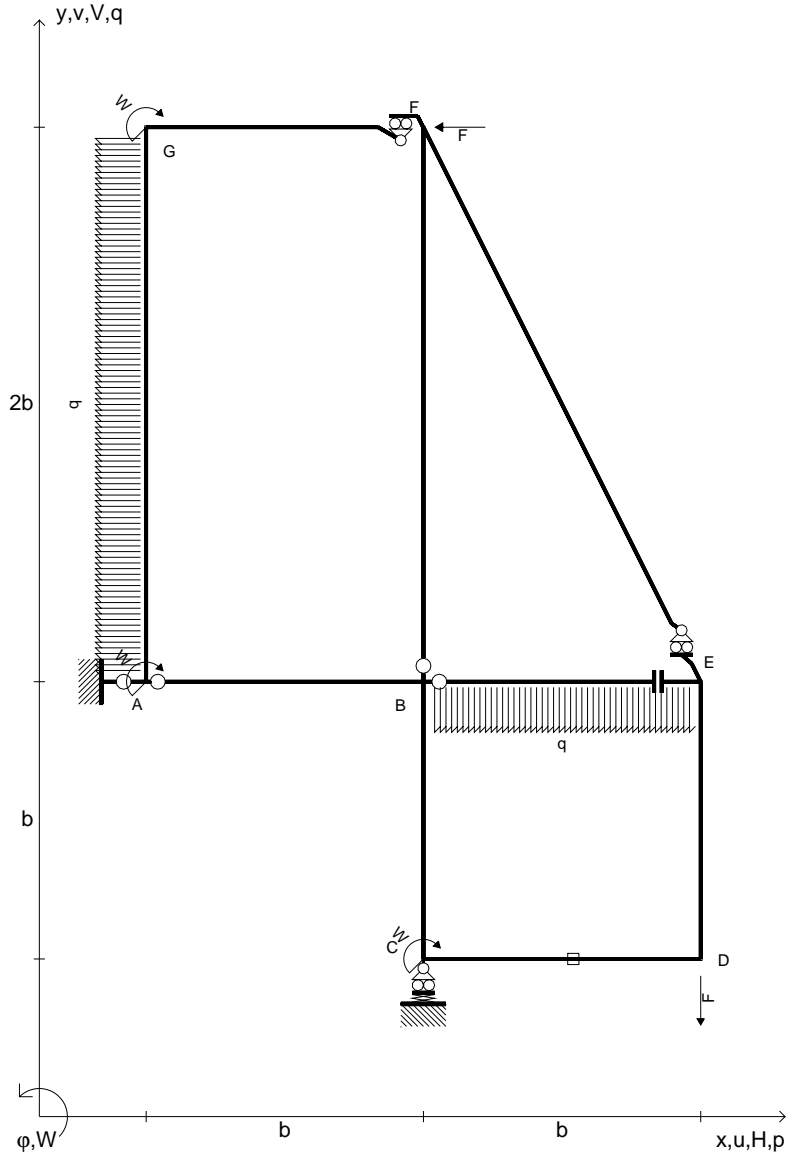

Reazioni iperstatiche in soluzione: $X=W_{DC}$
 Carichi e deformazioni date hanno verso efficace in disegno.
 Calcolare reazioni vincolari della struttura e delle aste.
 Tracciare i diagrammi quotati delle azioni interne nelle aste.
 $J_{YZ} - x_{YZ} - \theta_{YZ}$ riferimento locale asta YZ con origine in Y.
 Elongazione termica specifica ϵ assegnata su asta CD.
 © Adolfo Zavelani Rossi, Politecnico di Milano, vers.27.03.13

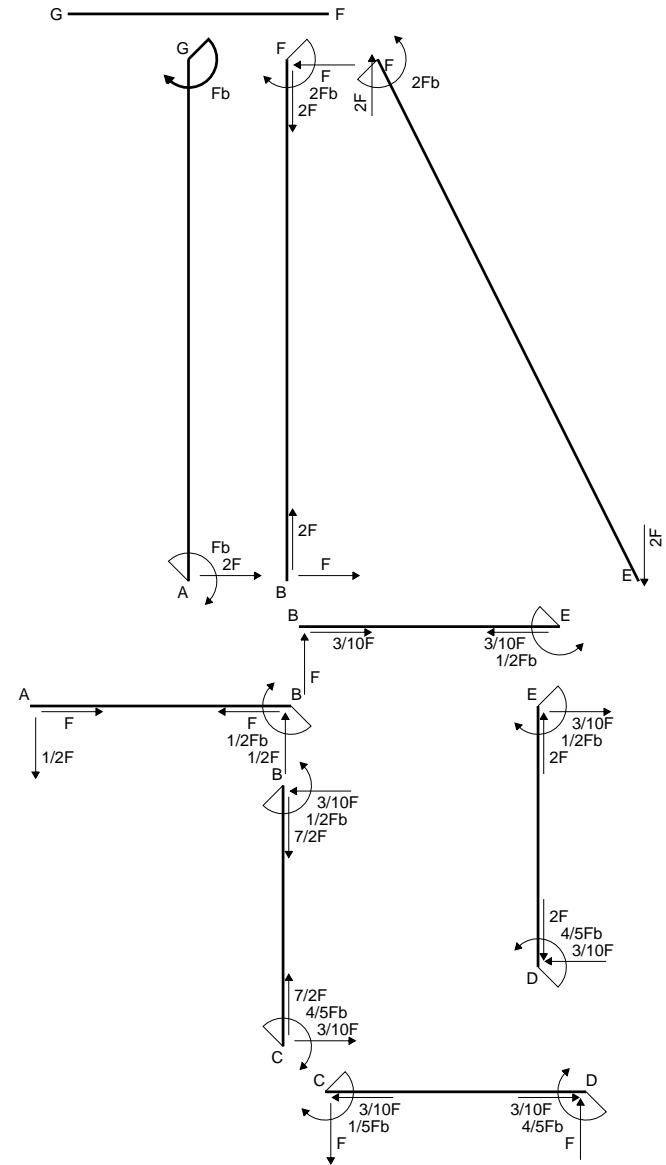

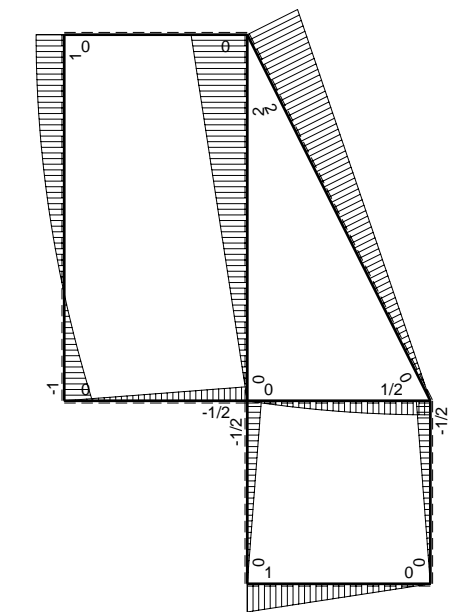
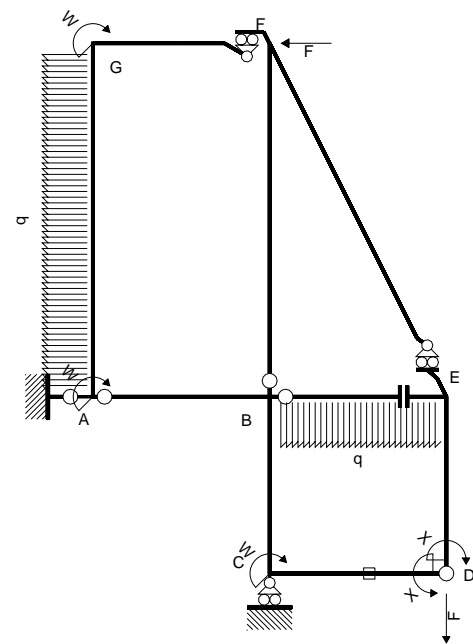
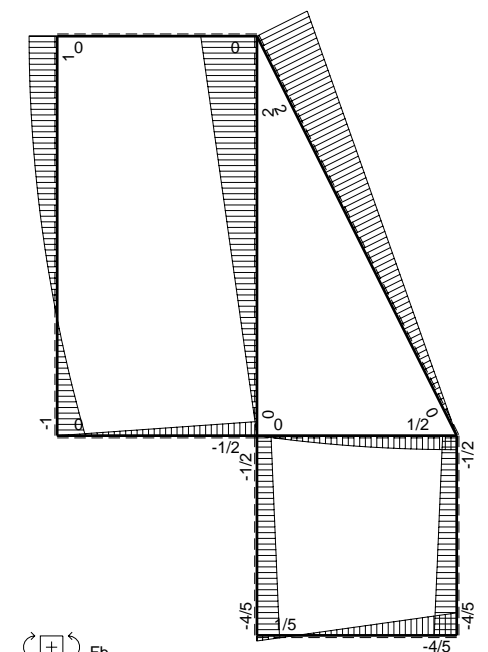
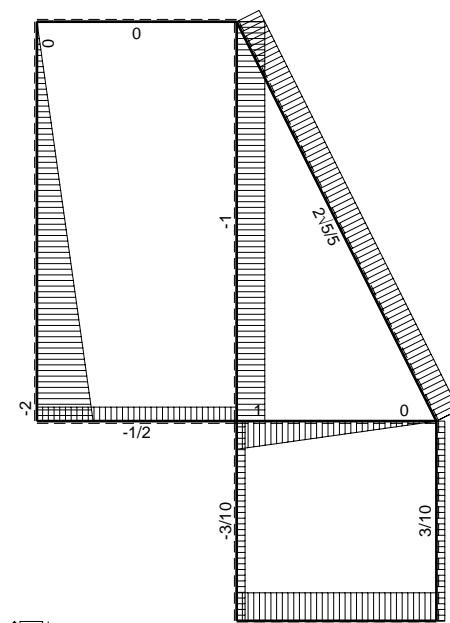
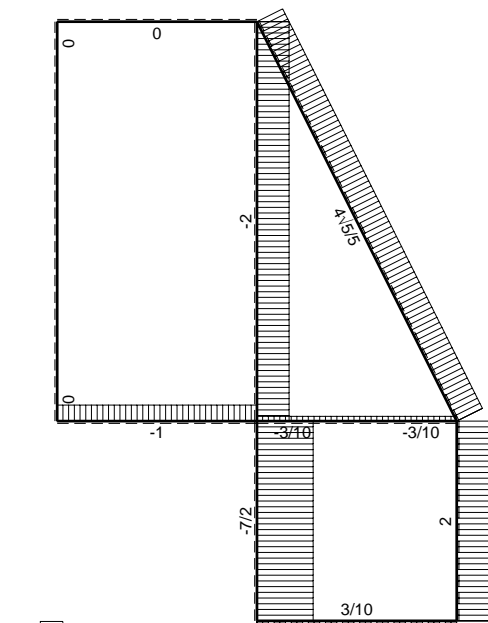

M_0 flessione da carichi assegnati

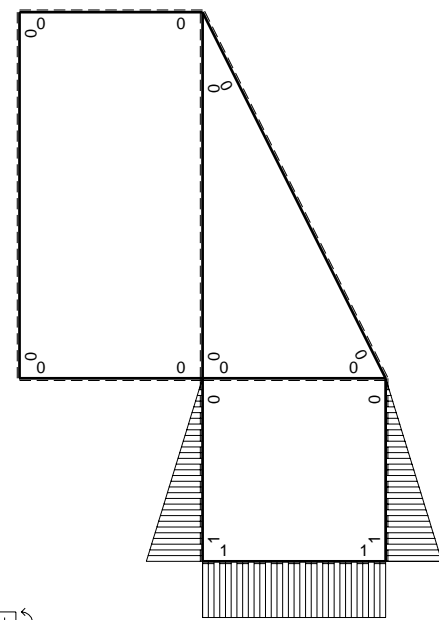

M_x flessione da iperstatica $X=1$

Quadro contributi PLV per iperstatica X=W_{DC}

→	M _x (x)	M _o (x)	M _x M _o	M _x M _x	∫M _x M _o /EJdx	∫XM _x M _x /EJdx
AB b	0	-1/2Fx	0	0	0	0
BA b	0	1/2Fb-1/2Fx	0	0		
BC b	x/b	-1/2Fb+1/2Fx	-1/2Fx+1/2Fx ² /b	x ² /b ²	-1/12Fb ² /EJ	1/3Xb/EJ
CB b	-1+x/b	1/2Fx	-1/2Fx+1/2Fx ² /b	1-2x/b+x ² /b ²		
CD b	1	Fb-Fx	Fb-Fx	1	1/2Fb ² /EJ	Xb/EJ
DC b	-1	-Fx	Fx	1		
DE b	1-x/b	-1/2Fx	-1/2Fx+1/2Fx ² /b	1-2x/b+x ² /b ²	-1/12Fb ² /EJ	1/3Xb/EJ
ED b	-x/b	1/2Fb-1/2Fx	-1/2Fx+1/2Fx ² /b	x ² /b ²		
EF √5b	0	2√5/5Fx	0	0	0	0
FG b	0	0	0	0	0	0
GF b	0	0	0	0		
GA 2b	0	Fb-1/2qx ²	0	0	0	0
AG 2b	0	Fb-2Fx+1/2qx ²	0	0		
FB 2b	0	2Fb-Fx	0	0	0	0
BF 2b	0	-Fx	0	0		
BE b	0	Fx-1/2qx ²	0	0	0	0
EB b	0	-1/2Fb+1/2qx ²	0	0		
CD	elongazione asta N _{1CD} ε _{CD} L _{CD}				Fb ² /EJ	
	totali				4/3Fb ² /EJ	5/3Xb/EJ
	iperstatica X=W _{DC}				-4/5Fb	

Sviluppi di calcolo iperstatica

$$L_{BC}^{xx} = \int_0^b (x^2/b^2) 1/EJ dx = [1/3 x^3/b^2]_0^b 1/EJ = (1/3 b) 1/EJ = 1/3 b/EJ$$

$$L_{CB}^{xx} = \int_0^b (1 - 2x/b + x^2/b^2) 1/EJ dx = [x - x^2/b + 1/3 x^3/b^2]_0^b 1/EJ = (b - b + 1/3 b) 1/EJ = 1/3 b/EJ$$

$$L_{CD}^{xx} = \int_0^b (1) 1/EJ dx = [x]_0^b 1/EJ = (b) 1/EJ = b/EJ$$

$$L_{DC}^{xx} = \int_0^b (1) 1/EJ dx = [x]_0^b 1/EJ = (b) 1/EJ = b/EJ$$

$$L_{DE}^{xx} = \int_0^b (1 - 2x/b + x^2/b^2) 1/EJ dx = [x - x^2/b + 1/3 x^3/b^2]_0^b 1/EJ = (b - b + 1/3 b) 1/EJ = 1/3 b/EJ$$

$$L_{ED}^{xx} = \int_0^b (x^2/b^2) 1/EJ dx = [1/3 x^3/b^2]_0^b 1/EJ = (1/3 b) 1/EJ = 1/3 b/EJ$$

$$L_{BC}^{xo} = \int_0^b (-1/2 x/b + 1/2 x^2/b^2) Fb 1/EJ dx = [-1/4 x^2/b + 1/6 x^3/b^2]_0^b Fb 1/EJ = (-1/4 b + 1/6 b) Fb 1/EJ = -1/12 Fb²/EJ$$

$$L_{CB}^{xo} = \int_0^b (-1/2 x/b + 1/2 x^2/b^2) Fb 1/EJ dx = [-1/4 x^2/b + 1/6 x^3/b^2]_0^b Fb 1/EJ = (-1/4 b + 1/6 b) Fb 1/EJ = -1/12 Fb²/EJ$$

$$L_{CD}^{xo} = \int_0^b (1 - x/b) Fb 1/EJ dx - 1 (-1) 1 Fb^2/EJ = [x - 1/2 x^2/b]_0^b Fb 1/EJ - 1 (-1) 1 Fb^2/EJ = (b - 1/2 b) Fb 1/EJ - 1 (-1) 1 Fb^2/EJ = 3/2 Fb²/EJ$$

$$L_{DC}^{xo} = \int_0^b (x/b) Fb 1/EJ dx - 1 (-1) 1 Fb^2/EJ = [1/2 x^2/b]_0^b Fb 1/EJ - 1 (-1) 1 Fb^2/EJ = (1/2 b) Fb 1/EJ - 1 (-1) 1 Fb^2/EJ = 3/2 Fb²/EJ$$

$$L_{DE}^{xo} = \int_0^b (-1/2 x/b + 1/2 x^2/b^2) Fb 1/EJ dx = [-1/4 x^2/b + 1/6 x^3/b^2]_0^b Fb 1/EJ = (-1/4 b + 1/6 b) Fb 1/EJ = -1/12 Fb²/EJ$$

$$L_{ED}^{xo} = \int_0^b (-1/2 x/b + 1/2 x^2/b^2) Fb 1/EJ dx = [-1/4 x^2/b + 1/6 x^3/b^2]_0^b Fb 1/EJ = (-1/4 b + 1/6 b) Fb 1/EJ = -1/12 Fb²/EJ$$

- $H_{FB} = -F$
- $V_D = -F$
- $W_C = -W = -Fb$
- $W_G = -W = -Fb$
- $W_A = -W = -Fb$
- $q_{BE} = -q = -F/b$
- $q_{FG} = -q = -F/b$
- $\epsilon_{BE} = -\alpha T = -b^2 F/EJ$
- $k_C = 4EJ/b^3$
- $EJ_{AB} = EJ$
- $EJ_{BC} = EJ$
- $EJ_{CD} = EJ$
- $EJ_{DE} = EJ$
- $EJ_{EF} = EJ$
- $EJ_{FG} = EJ$
- $EJ_{GA} = EJ$
- $EJ_{FB} = EJ$
- $EJ_{BE} = EJ$

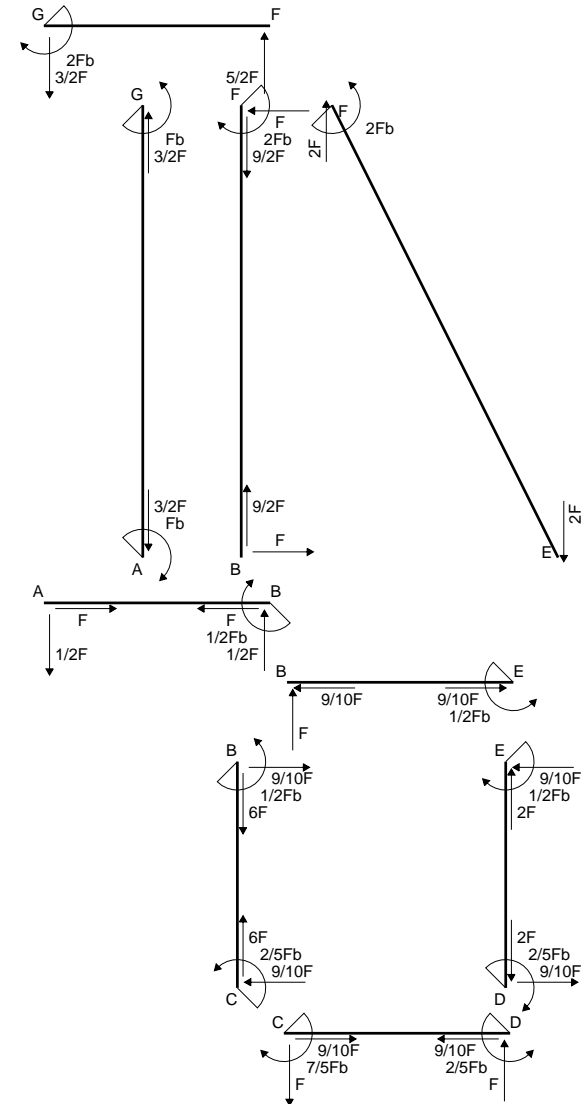
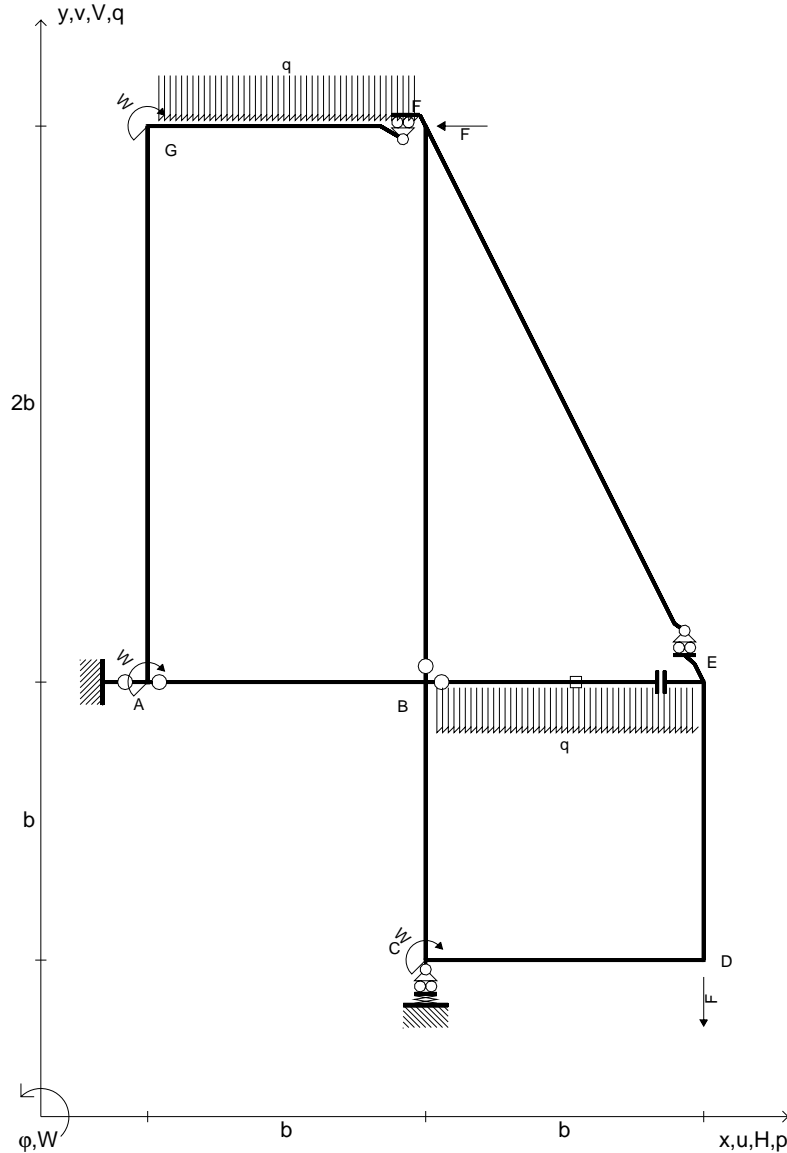

Reazioni iperstatiche in soluzione: $X=W_{DE}$
 Carichi e deformazioni date hanno verso efficace in disegno.
 Calcolare reazioni vincolari della struttura e delle aste.
 Tracciare i diagrammi quotati delle azioni interne nelle aste.
 $J_{YZ} - x_{YZ} - \theta_{YZ}$ riferimento locale asta YZ con origine in Y.
 Elongazione termica specifica ϵ assegnata su asta BE.
 © Adolfo Zavelani Rossi, Politecnico di Milano, vers.27.03.13

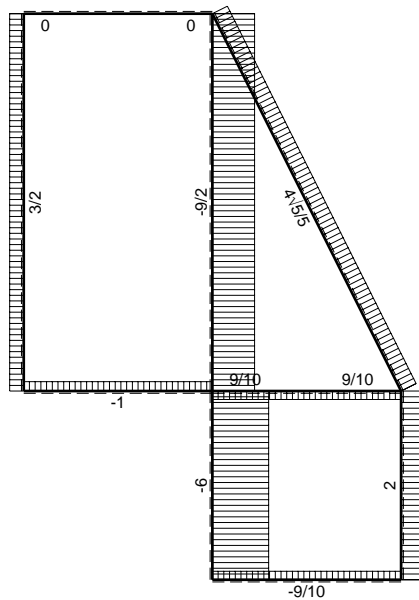

← (+) → F

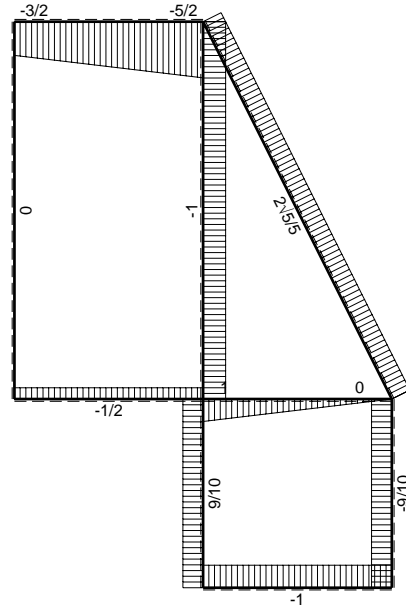

↑ (+) ↓ F

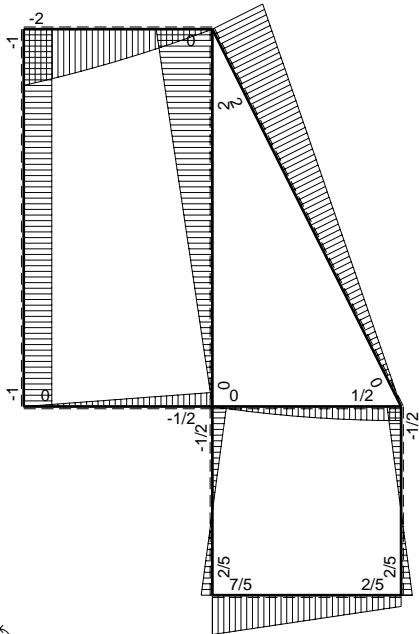

⊕ (+) ⊖ F_b

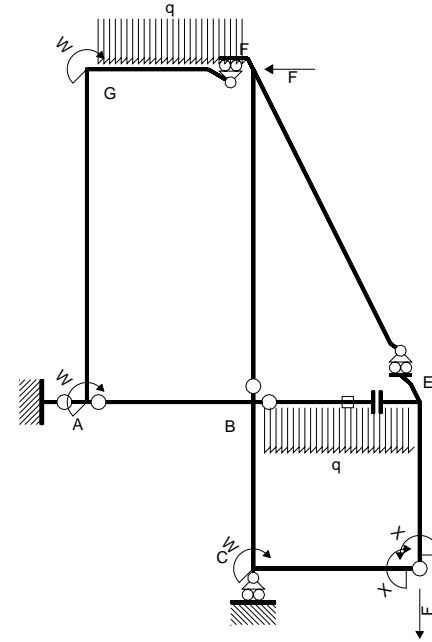

Schema di calcolo iperstatico

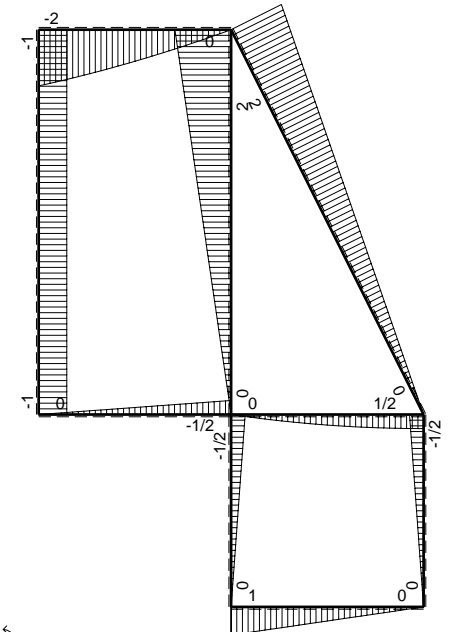

⊕ (+) ⊖ M₀ flessione da carichi assegnati

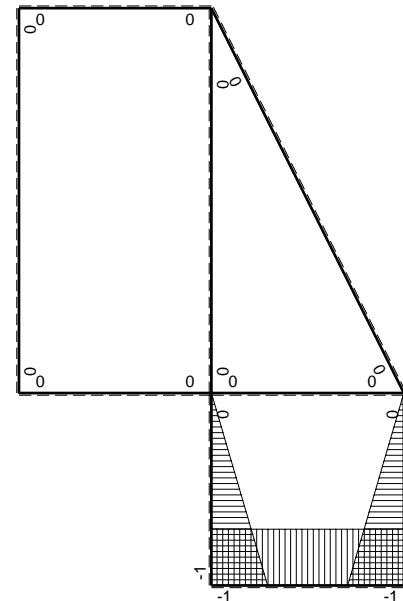

⊕ (+) ⊖ M_x flessione da iperstatica X=1

Quadro contributi PLV per iperstatica $X=W_{DE}$

→	$M_x(x)$	$M_o(x)$	$M_x M_o$	$M_x M_x$	$\int M_x M_o / EJ dx$	$\int X M_x M_x / EJ dx$
AB b	0	-1/2Fx	0	0	0	0
BA b	0	1/2Fb-1/2Fx	0	0	0	0
BC b	-x/b	-1/2Fb+1/2Fx	1/2Fx-1/2Fx ² /b	x ² /b ²	1/12Fb ² /EJ	1/3Xb/EJ
CB b	1-x/b	1/2Fx	1/2Fx-1/2Fx ² /b	1-2x/b+x ² /b ²	1/12Fb ² /EJ	1/3Xb/EJ
CD b	-1	Fb-Fx	-Fb+Fx	1	-1/2Fb ² /EJ	Xb/EJ
DC b	1	-Fx	-Fx	1	-1/2Fb ² /EJ	Xb/EJ
DE b	-1+x/b	-1/2Fx	1/2Fx-1/2Fx ² /b	1-2x/b+x ² /b ²	1/12Fb ² /EJ	1/3Xb/EJ
ED b	x/b	1/2Fb-1/2Fx	1/2Fx-1/2Fx ² /b	x ² /b ²	1/12Fb ² /EJ	1/3Xb/EJ
EF √5b	0	2√5/5Fx	0	0	0	0
FG b	0	-5/2Fx+1/2qx ²	0	0	0	0
GF b	0	2Fb-3/2Fx-1/2qx ²	0	0	0	0
GA 2b	0	-Fb	0	0	0	0
AG 2b	0	Fb	0	0	0	0
FB 2b	0	2Fb-Fx	0	0	0	0
BF 2b	0	-Fx	0	0	0	0
BE b	0	Fx-1/2qx ²	0	0	0	0
EB b	0	-1/2Fb+1/2qx ²	0	0	0	0
BE	elongazione asta $N_{1BE} \epsilon_{BE} L_{BE}$				Fb ² /EJ	
	totali				2/3Fb ² /EJ	5/3Xb/EJ
	iperstatica $X=W_{DE}$				-2/5Fb	

Sviluppi di calcolo iperstatica

$$L_{BC}^{xx} = \int_0^b (x^2/b^2) 1/EJ dx = [1/3 x^3/b^2]_0^b 1/EJ$$

$$= (1/3 b) 1/EJ = 1/3 b/EJ$$

$$L_{CB}^{xx} = \int_0^b (1 - 2x/b + x^2/b^2) 1/EJ dx = [x - x^2/b + 1/3 x^3/b^2]_0^b 1/EJ$$

$$= (b - b + 1/3 b) 1/EJ = 1/3 b/EJ$$

$$L_{CD}^{xx} = \int_0^b (1) 1/EJ dx = [x]_0^b 1/EJ$$

$$= (b) 1/EJ = b/EJ$$

$$L_{DC}^{xx} = \int_0^b (1) 1/EJ dx = [x]_0^b 1/EJ$$

$$= (b) 1/EJ = b/EJ$$

$$L_{DE}^{xx} = \int_0^b (1 - 2x/b + x^2/b^2) 1/EJ dx = [x - x^2/b + 1/3 x^3/b^2]_0^b 1/EJ$$

$$= (b - b + 1/3 b) 1/EJ = 1/3 b/EJ$$

$$L_{ED}^{xx} = \int_0^b (x^2/b^2) 1/EJ dx = [1/3 x^3/b^2]_0^b 1/EJ$$

$$= (1/3 b) 1/EJ = 1/3 b/EJ$$

$$L_{BC}^{xo} = \int_0^b (1/2 x/b - 1/2 x^2/b^2) Fb 1/EJ dx = [1/4 x^2/b - 1/6 x^3/b^2]_0^b Fb 1/EJ$$

$$= (1/4 b - 1/6 b) Fb 1/EJ = 1/12 Fb^2/EJ$$

$$L_{CB}^{xo} = \int_0^b (1/2 x/b - 1/2 x^2/b^2) Fb 1/EJ dx = [1/4 x^2/b - 1/6 x^3/b^2]_0^b Fb 1/EJ$$

$$= (1/4 b - 1/6 b) Fb 1/EJ = 1/12 Fb^2/EJ$$

$$L_{CD}^{xo} = \int_0^b (-1 + x/b) Fb 1/EJ dx = [-x + 1/2 x^2/b]_0^b Fb 1/EJ$$

$$= (-b + 1/2 b) Fb 1/EJ = -1/2 Fb^2/EJ$$

$$L_{DC}^{xo} = \int_0^b (-x/b) Fb 1/EJ dx = [-1/2 x^2/b]_0^b Fb 1/EJ$$

$$= (-1/2 b) Fb 1/EJ = -1/2 Fb^2/EJ$$

$$L_{DE}^{xo} = \int_0^b (1/2 x/b - 1/2 x^2/b^2) Fb 1/EJ dx = [1/4 x^2/b - 1/6 x^3/b^2]_0^b Fb 1/EJ$$

$$= (1/4 b - 1/6 b) Fb 1/EJ = 1/12 Fb^2/EJ$$

$$L_{ED}^{xo} = \int_0^b (1/2 x/b - 1/2 x^2/b^2) Fb 1/EJ dx = [1/4 x^2/b - 1/6 x^3/b^2]_0^b Fb 1/EJ$$

$$= (1/4 b - 1/6 b) Fb 1/EJ = 1/12 Fb^2/EJ$$

- $H_{FB} = -F$
- $V_D = -F$
- $W_C = -W = -Fb$
- $W_G = -W = -Fb$
- $W_A = -W = -Fb$
- $p_{GA} = -q = -F/b$
- $p_{FB} = -q = -F/b$
- $\epsilon_{BE} = -\alpha T = -b^2 F/EJ$
- $k_C = 4EJ/b^3$
- $EJ_{AB} = EJ$
- $EJ_{BC} = EJ$
- $EJ_{CD} = EJ$
- $EJ_{DE} = EJ$
- $EJ_{EF} = EJ$
- $EJ_{FG} = EJ$
- $EJ_{GA} = EJ$
- $EJ_{FB} = EJ$
- $EJ_{BE} = EJ$

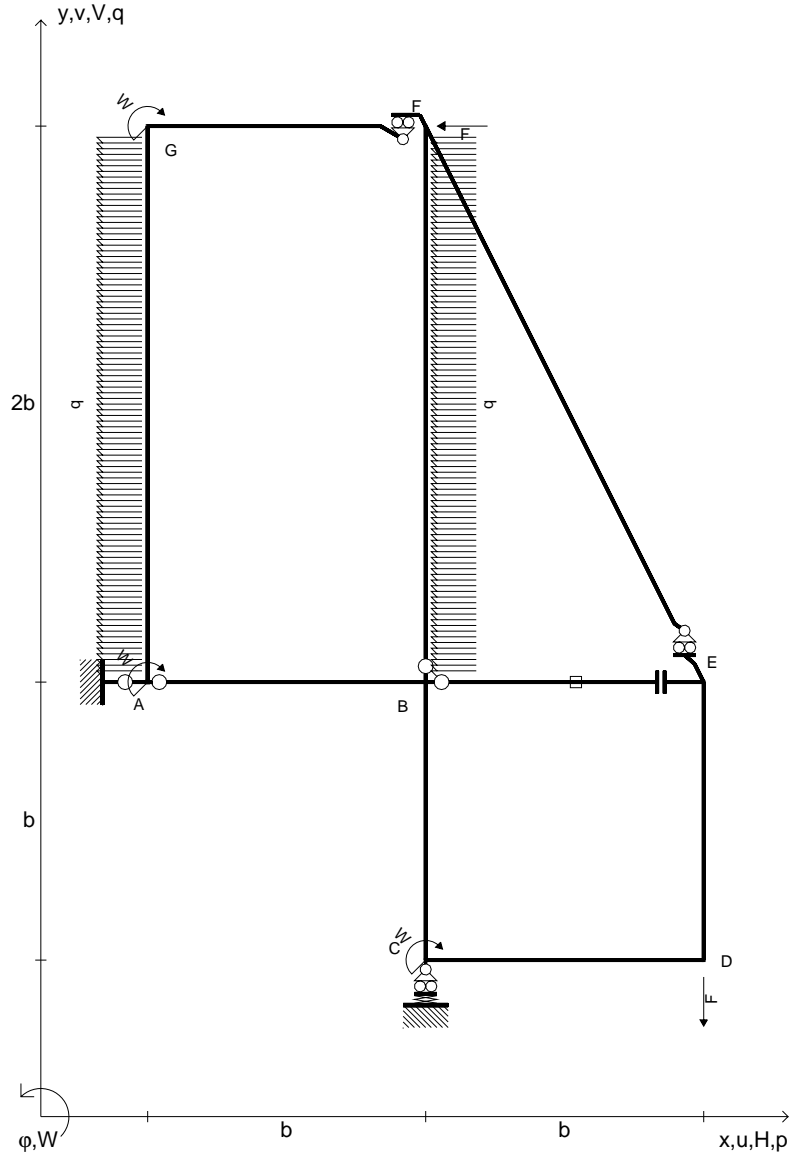

Reazioni iperstatiche in soluzione: $X=W_{DE}$
 Carichi e deformazioni date hanno verso efficace in disegno.
 Calcolare reazioni vincolari della struttura e delle aste.
 Tracciare i diagrammi quotati delle azioni interne nelle aste.
 $J_{YZ} - x_{YZ} - \theta_{YZ}$ riferimento locale asta YZ con origine in Y.
 Elongazione termica specifica ϵ assegnata su asta BE.
 © Adolfo Zavelani Rossi, Politecnico di Milano, vers.27.03.13

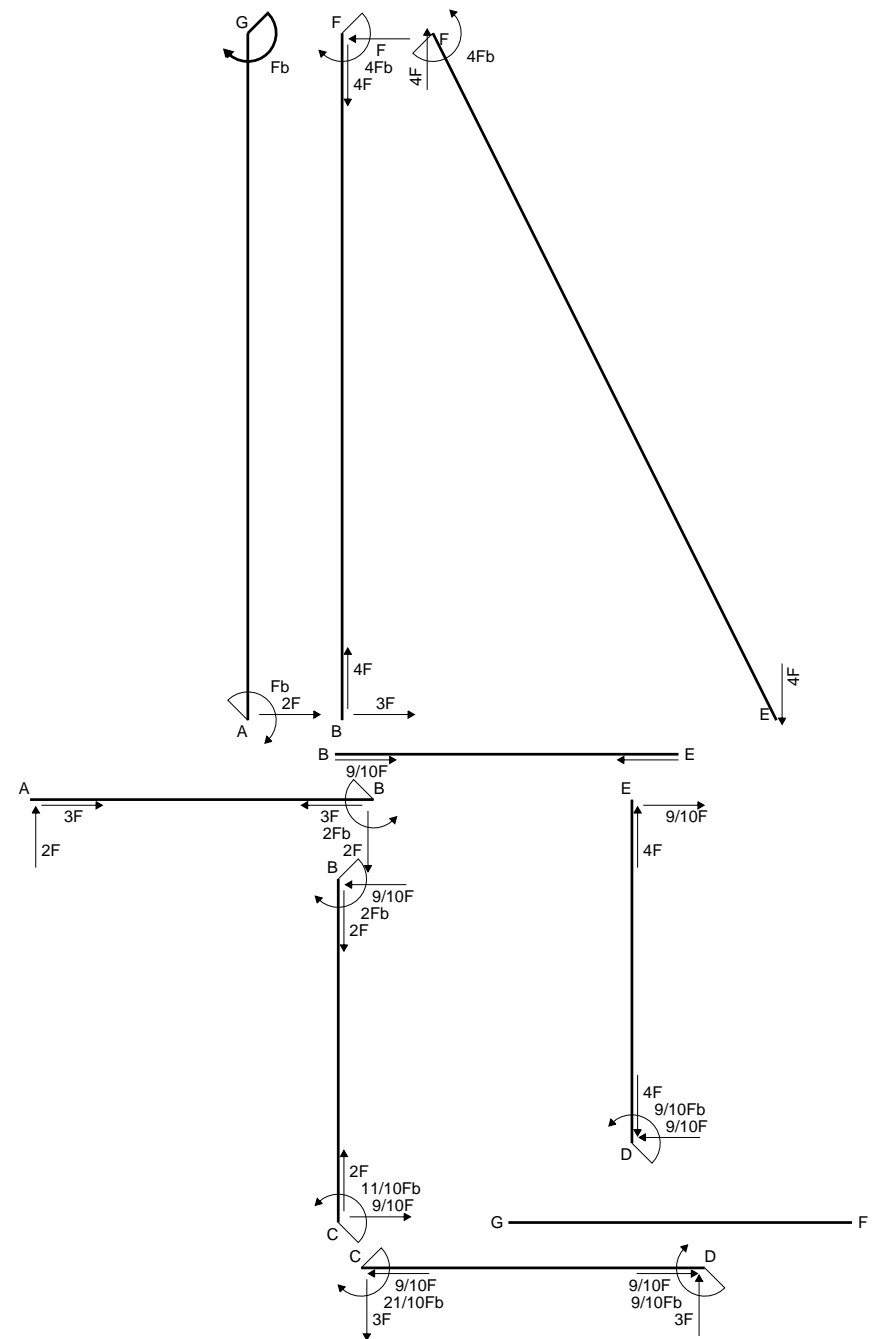

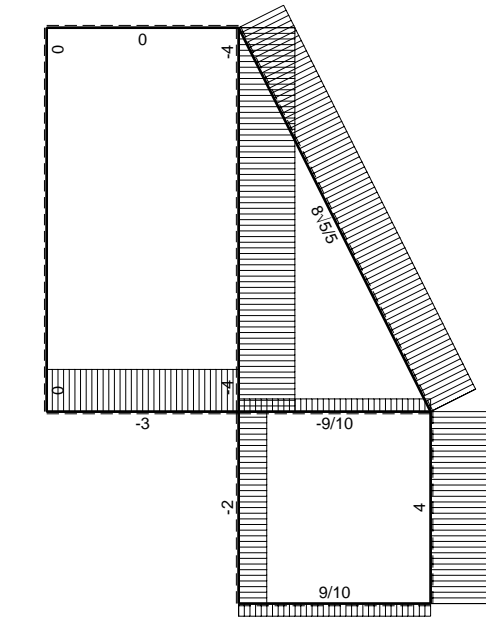

← (+) → F

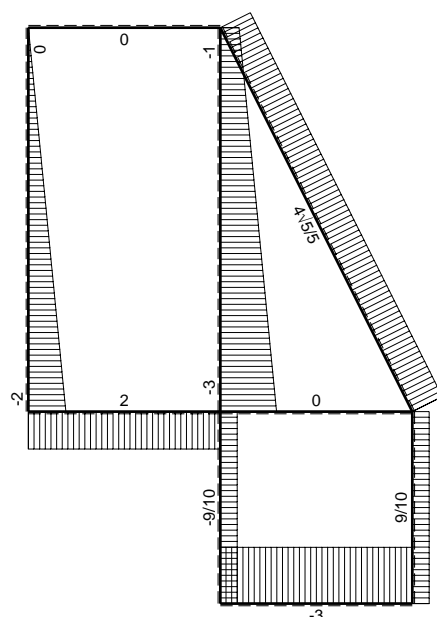

↑ (+) ↓ F

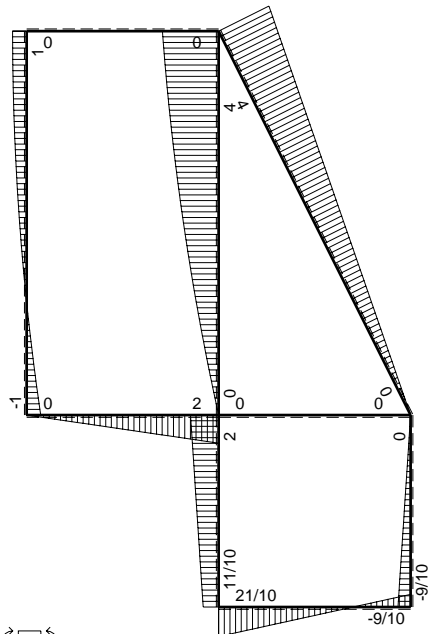

⌚ (+) ↻ F_b

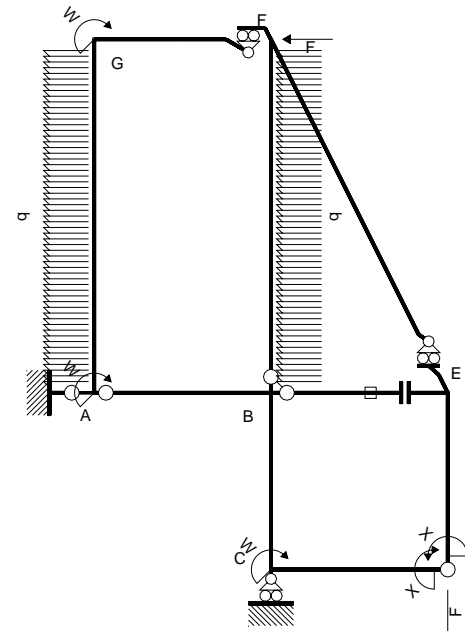

Schema di calcolo iperstatico

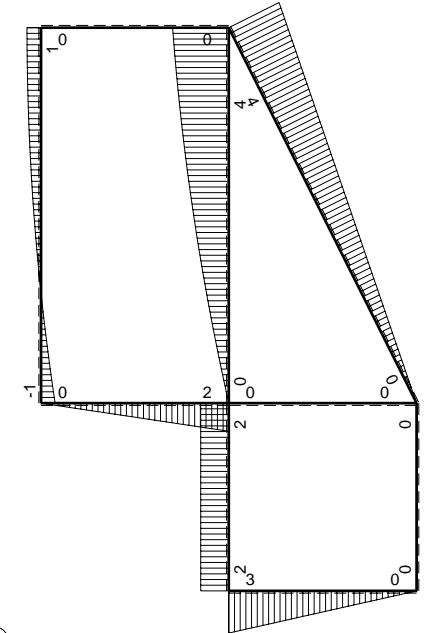

⌚ (+) ↻ M₀ flessione da carichi assegnati

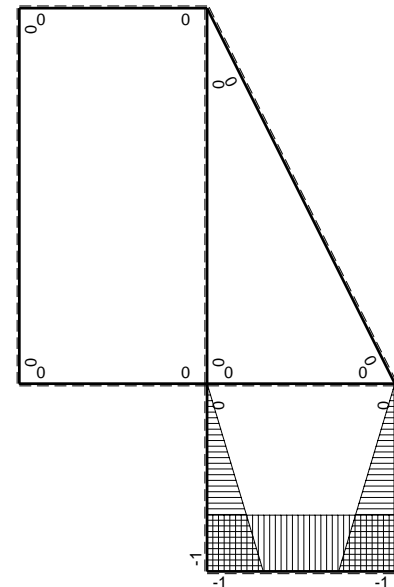

⌚ (+) ↻ M_x flessione da iperstatica X=1

Quadro contributi PLV per iperstatica $X=W_{DE}$

→	$M_x(x)$	$M_o(x)$	$M_x M_o$	$M_x M_x$	$\int M_x M_o / EJ dx$	$\int X M_x M_x / EJ dx$
AB b	0	2Fx	0	0	0	0
BA b	0	-2Fb+2Fx	0	0	0	0
BC b	-x/b	2Fb	-2Fx	x^2/b^2	$-Fb^2/EJ$	$1/3Xb/EJ$
CB b	1-x/b	-2Fb	-2Fb+2Fx	$1-2x/b+x^2/b^2$	0	$1/3Xb/EJ$
CD b	-1	3Fb-3Fx	-3Fb+3Fx	1	$-3/2Fb^2/EJ$	Xb/EJ
DC b	1	-3Fx	-3Fx	1	0	$1/3Xb/EJ$
DE b	-1+x/b	0	0	$1-2x/b+x^2/b^2$	0	0
ED b	x/b	0	0	x^2/b^2	0	0
EF $\sqrt{5}b$	0	$4\sqrt{5}/5Fx$	0	0	0	0
FG b	0	0	0	0	0	0
GF b	0	0	0	0	0	0
GA 2b	0	$Fb-1/2qx^2$	0	0	0	0
AG 2b	0	$Fb-2Fx+1/2qx^2$	0	0	0	0
FB 2b	0	$4Fb-Fx-1/2qx^2$	0	0	0	0
BF 2b	0	$-3Fx+1/2qx^2$	0	0	0	0
BE b	0	0	0	0	0	0
EB b	0	0	0	0	0	0
BE	elongazione asta $N_{1BE} \epsilon_{BE} L_{BE}$				Fb^2/EJ	
	totali				$-3/2Fb^2/EJ$	$5/3Xb/EJ$
	iperstatica $X=W_{DE}$				$9/10Fb$	

Sviluppi di calcolo iperstatica

$$L_{BC}^{xx} = \int_0^b (x^2/b^2) 1/EJ dx = [1/3 x^3/b^2]_0^b 1/EJ = (1/3 b) 1/EJ = 1/3 b/EJ$$

$$L_{CB}^{xx} = \int_0^b (-2 x/b + x^2/b^2) 1/EJ dx = [x - x^2/b + 1/3 x^3/b^2]_0^b 1/EJ = (b - b + 1/3 b) 1/EJ = 1/3 b/EJ$$

$$L_{CD}^{xx} = \int_0^b (1) 1/EJ dx = [x]_0^b 1/EJ = (b) 1/EJ = b/EJ$$

$$L_{DC}^{xx} = \int_0^b (1) 1/EJ dx = [x]_0^b 1/EJ = (b) 1/EJ = b/EJ$$

$$L_{DE}^{xx} = \int_0^b (-2 x/b + x^2/b^2) 1/EJ dx = [x - x^2/b + 1/3 x^3/b^2]_0^b 1/EJ = (b - b + 1/3 b) 1/EJ = 1/3 b/EJ$$

$$L_{ED}^{xx} = \int_0^b (x^2/b^2) 1/EJ dx = [1/3 x^3/b^2]_0^b 1/EJ = (1/3 b) 1/EJ = 1/3 b/EJ$$

$$L_{BC}^{xo} = \int_0^b (-2 x/b) Fb 1/EJ dx = [-x^2/b]_0^b Fb 1/EJ = (-b) Fb 1/EJ = - Fb^2/EJ$$

$$L_{CB}^{xo} = \int_0^b (-2 + 2 x/b) Fb 1/EJ dx = [-2x + x^2/b]_0^b Fb 1/EJ = (-2b + b) Fb 1/EJ = - Fb^2/EJ$$

$$L_{CD}^{xo} = \int_0^b (-3 + 3 x/b) Fb 1/EJ dx = [-3x + 3/2 x^2/b]_0^b Fb 1/EJ = (-3b + 3/2 b) Fb 1/EJ = -3/2 Fb^2/EJ$$

$$L_{DC}^{xo} = \int_0^b (-3 x/b) Fb 1/EJ dx = [-3/2 x^2/b]_0^b Fb 1/EJ = (-3/2 b) Fb 1/EJ = -3/2 Fb^2/EJ$$

- $H_{FB} = -F$
- $V_D = -F$
- $W_C = -W = -Fb$
- $W_G = -W = -Fb$
- $W_A = -W = -Fb$
- $p_{GA} = -q = -F/b$
- $q_{FG} = -q = -F/b$
- $\epsilon_{BE} = -\alpha T = -b^2 F/EJ$
- $k_C = 4EJ/b^3$
- $EJ_{AB} = EJ$
- $EJ_{BC} = EJ$
- $EJ_{CD} = EJ$
- $EJ_{DE} = EJ$
- $EJ_{EF} = EJ$
- $EJ_{FG} = EJ$
- $EJ_{GA} = EJ$
- $EJ_{FB} = EJ$
- $EJ_{BE} = EJ$

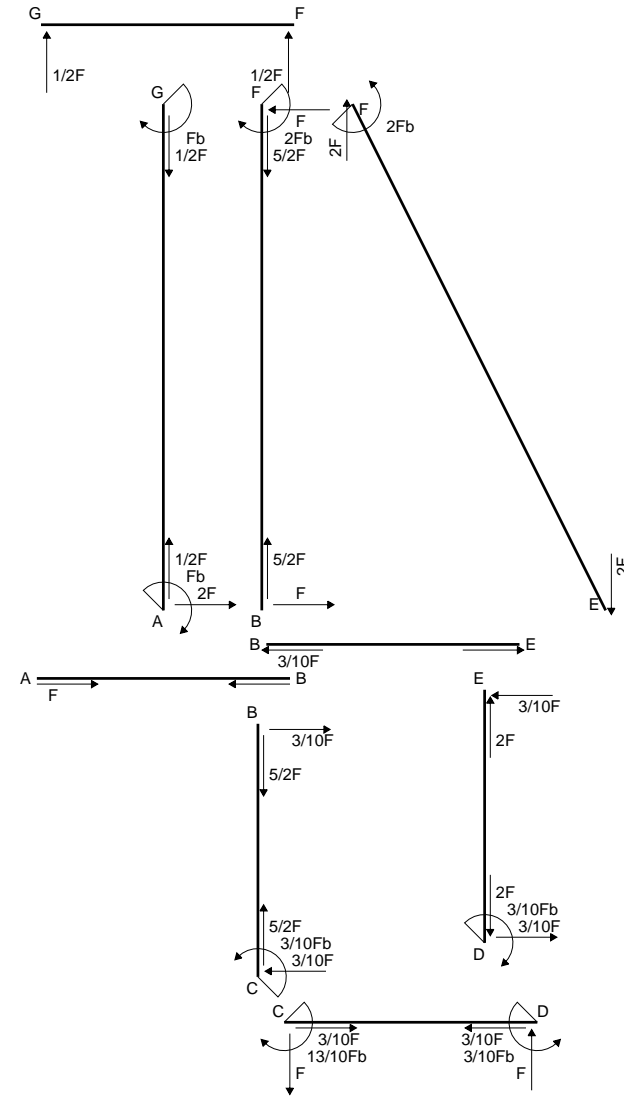
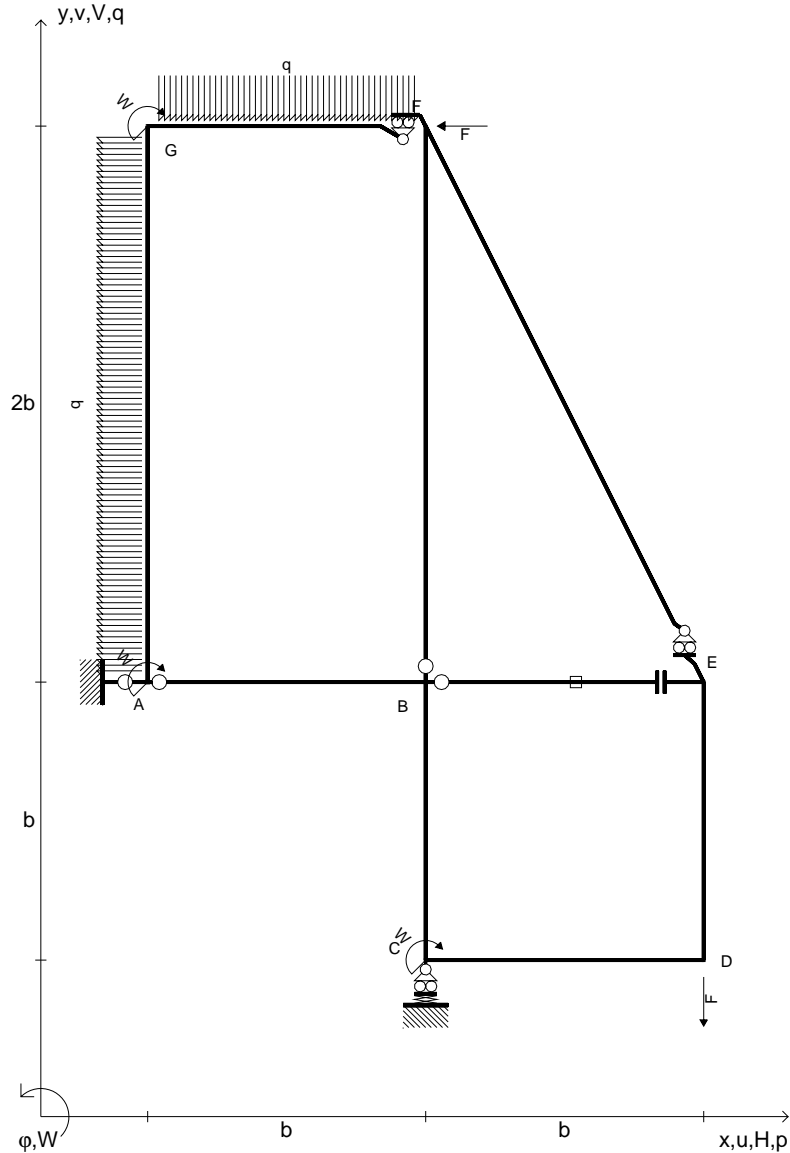

Reazioni iperstatiche in soluzione: $X=H_{BE}$
 Carichi e deformazioni date hanno verso efficace in disegno.
 Calcolare reazioni vincolari della struttura e delle aste.
 Tracciare i diagrammi quotati delle azioni interne nelle aste.
 $J_{YZ} - x_{YZ} - \theta_{YZ}$ riferimento locale asta YZ con origine in Y.
 Elongazione termica specifica ϵ assegnata su asta BE.
 © Adolfo Zavelani Rossi, Politecnico di Milano, vers.27.03.13

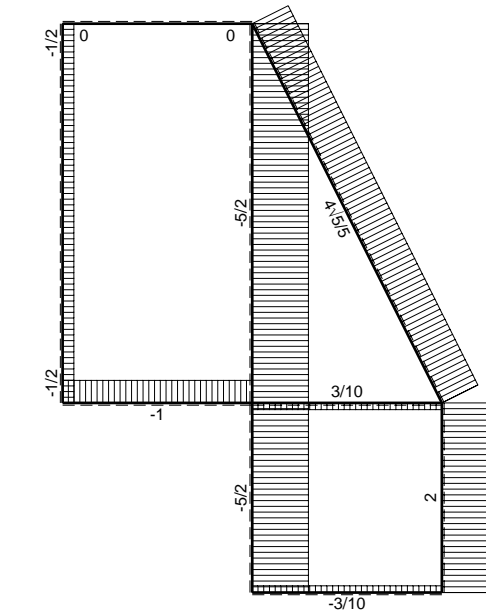

← ⊕ → F

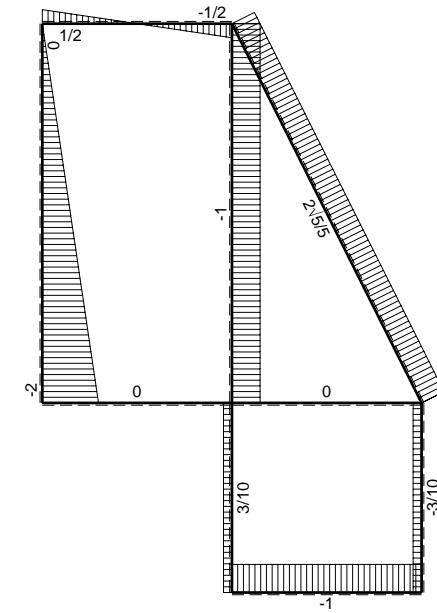

↑ ⊕ ↓ F

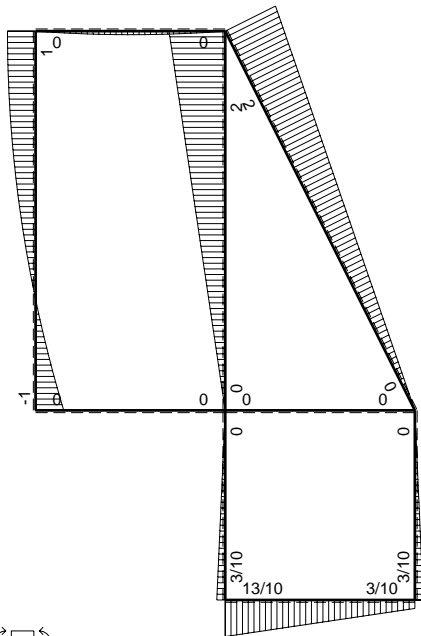

⊕ F_b

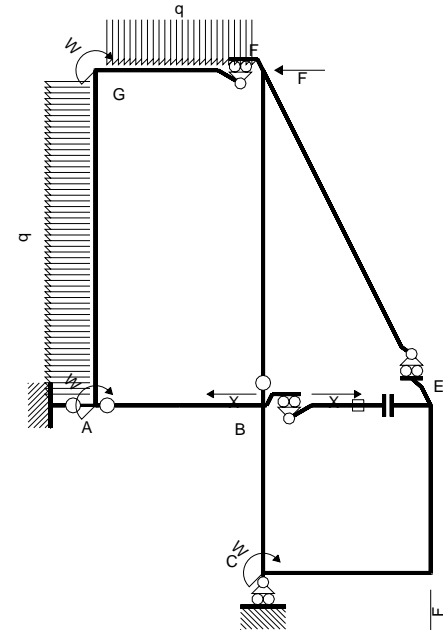

Schema di calcolo iperstatico

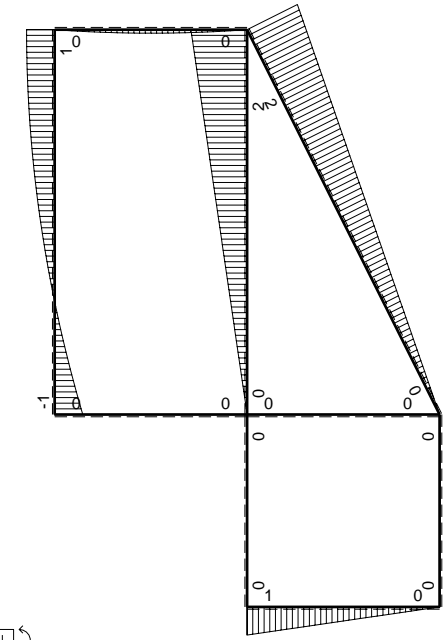

⊕ M₀ flessione da carichi assegnati

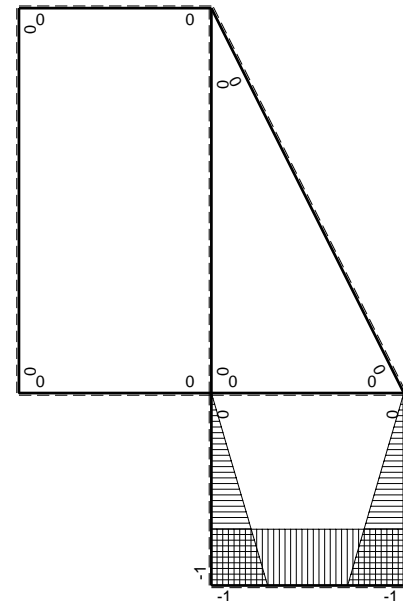

⊕ M_x flessione da iperstatica X=1

Quadro contributi PLV per iperstatica X=H_{BE}

→	M _x (x)	M _o (x)	M _x M _o	M _x M _x	∫M _x M _o /EJdx	∫XM _x M _x /EJdx
AB b	0	0	0	0	0	0
BA b	0	0	0	0		
BC b	-x	0	0	x ²	0	1/3Xb ³ /EJ
CB b	b-x	0	0	b ² -2bx+x ²		
CD b	-b	Fb-Fx	-Fb ² +Fbx	b ²	-1/2Fb ³ /EJ	Xb ³ /EJ
DC b	b	-Fx	-Fbx	b ²		
DE b	-b+x	0	0	b ² -2bx+x ²	0	1/3Xb ³ /EJ
ED b	x	0	0	x ²		
EF √5b	0	2√5/5Fx	0	0	0	0
FG b	0	-1/2Fx+1/2qx ²	0	0	0	0
GF b	0	1/2Fx-1/2qx ²	0	0		
GA 2b	0	Fb-1/2qx ²	0	0	0	0
AG 2b	0	Fb-2Fx+1/2qx ²	0	0		
FB 2b	0	2Fb-Fx	0	0	0	0
BF 2b	0	-Fx	0	0		
BE b	0	0	0	0	0	0
EB b	0	0	0	0		
BE	elongazione asta N _{1BE} ε _{BE} L _{BE}				Fb ³ /EJ	
	totali				1/2Fb ³ /EJ	5/3Xb ³ /EJ
	iperstatica X=H _{BE}				-3/10F	

Sviluppi di calcolo iperstatica

$$L_{BC}^{XX} = \int_0^b (x^2/b^2) b^2 1/EJ dx = [1/3 x^3/b^2]_0^b b^2 1/EJ$$

$$= (1/3 b) b^2 1/EJ = 1/3 b^3/EJ$$

$$L_{CB}^{XX} = \int_0^b (1 - 2x/b + x^2/b^2) b^2 1/EJ dx = [x - x^2/b + 1/3 x^3/b^2]_0^b b^2 1/EJ$$

$$= (b - b + 1/3 b) b^2 1/EJ = 1/3 b^3/EJ$$

$$L_{CD}^{XX} = \int_0^b (1) b^2 1/EJ dx = [x]_0^b b^2 1/EJ$$

$$= (b) b^2 1/EJ = b^3/EJ$$

$$L_{DC}^{XX} = \int_0^b (1) b^2 1/EJ dx = [x]_0^b b^2 1/EJ$$

$$= (b) b^2 1/EJ = b^3/EJ$$

$$L_{DE}^{XX} = \int_0^b (1 - 2x/b + x^2/b^2) b^2 1/EJ dx = [x - x^2/b + 1/3 x^3/b^2]_0^b b^2 1/EJ$$

$$= (b - b + 1/3 b) b^2 1/EJ = 1/3 b^3/EJ$$

$$L_{ED}^{XX} = \int_0^b (x^2/b^2) b^2 1/EJ dx = [1/3 x^3/b^2]_0^b b^2 1/EJ$$

$$= (1/3 b) b^2 1/EJ = 1/3 b^3/EJ$$

$$L_{CD}^{Xo} = \int_0^b (-1 + x/b) Fb^2 1/EJ dx = [-x + 1/2 x^2/b]_0^b Fb^2 1/EJ$$

$$= (-b + 1/2 b) Fb^2 1/EJ = -1/2 Fb^3/EJ$$

$$L_{DC}^{Xo} = \int_0^b (-x/b) Fb^2 1/EJ dx = [-1/2 x^2/b]_0^b Fb^2 1/EJ$$

$$= (-1/2 b) Fb^2 1/EJ = -1/2 Fb^3/EJ$$

- $H_{FB} = -F$
- $V_D = -F$
- $W_C = -W = -Fb$
- $W_G = -W = -Fb$
- $W_A = -W = -Fb$
- $p_{EF} = -q = -F/b$
- $q_{EF} = -q = -F/b$
- $q_{BE} = -q = -F/b$
- $\epsilon_{BE} = -\alpha T = -b^2 F/EJ$
- $k_C = 4EJ/b^3$
- $EJ_{AB} = EJ$
- $EJ_{BC} = EJ$
- $EJ_{CD} = EJ$
- $EJ_{DE} = EJ$
- $EJ_{EF} = EJ$
- $EJ_{FG} = EJ$
- $EJ_{GA} = EJ$
- $EJ_{FB} = EJ$
- $EJ_{BE} = EJ$

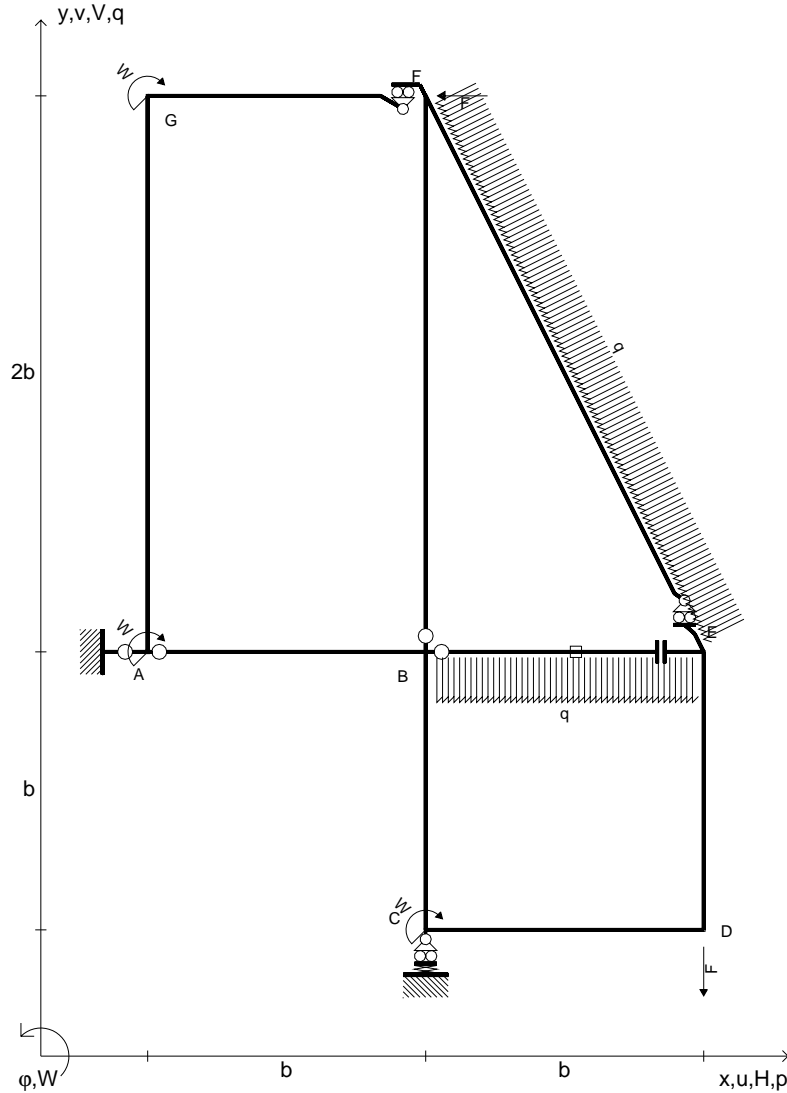

Reazioni iperstatiche in soluzione: $X=W_{DE}$
 Carichi e deformazioni date hanno verso efficace in disegno.
 Calcolare reazioni vincolari della struttura e delle aste.
 Tracciare i diagrammi quotati delle azioni interne nelle aste.
 Diagrammi di carico con valori riferiti ad asse della trave.
 Componenti di carico distribuito riferiti ad assi ortogonali.
 $J_{YZ} - x_{YZ} - \theta_{YZ}$ riferimento locale asta YZ con origine in Y.
 Elongazione termica specifica ϵ assegnata su asta BE.
 © Adolfo Zavelani Rossi, Politecnico di Milano, vers.27.03.13

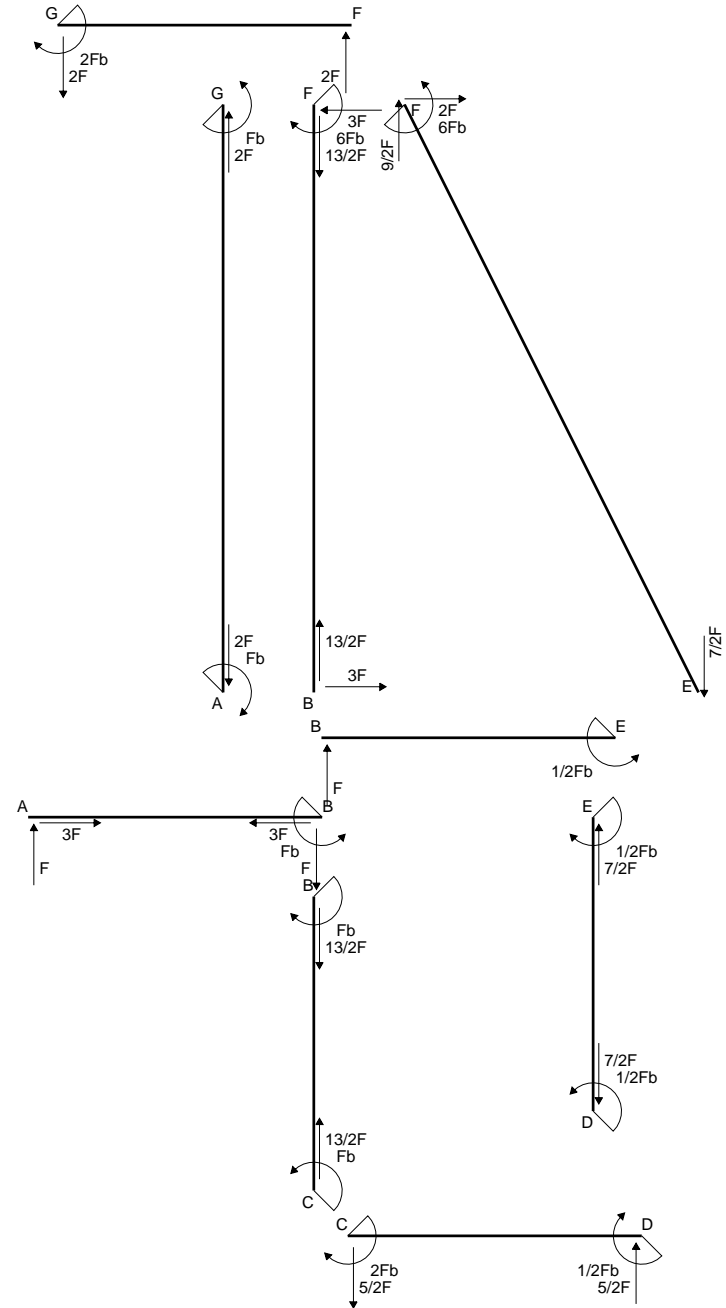

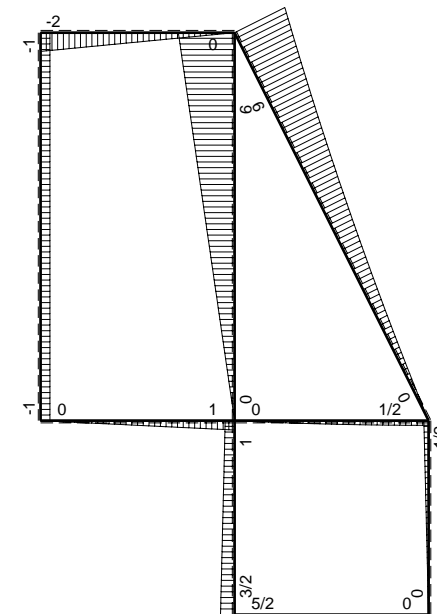
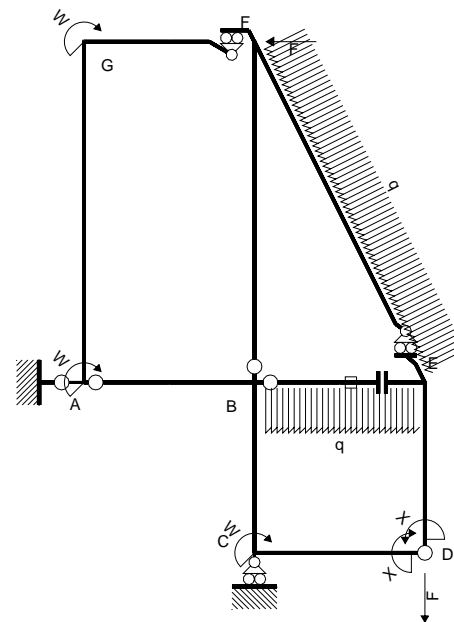
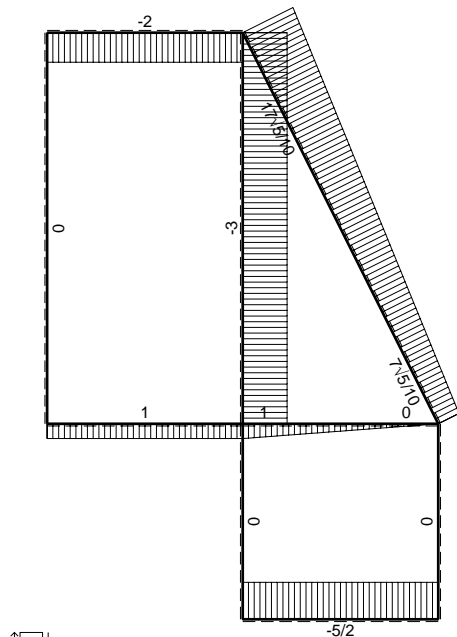
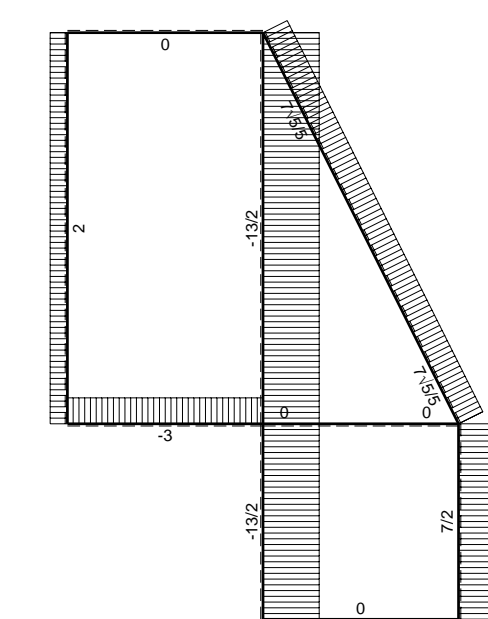

Schema di calcolo iperstatico

M_0 flessione da carichi assegnati

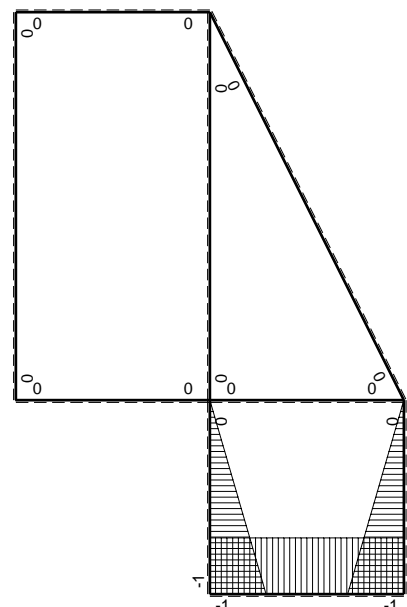
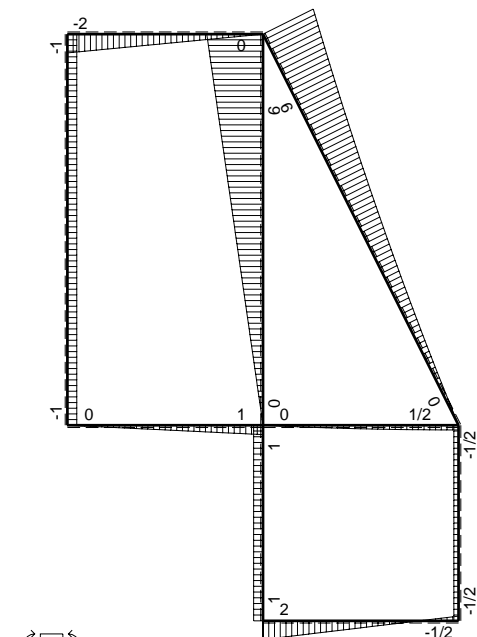

M_x flessione da iperstatica X=1

Quadro contributi PLV per iperstatica X=W_{DE}

→	M _x (x)	M _o (x)	M _x M _o	M _x M _x	∫M _x M _o /EJdx	∫XM _x M _x /EJdx
AB b	0	Fx	0	0	0	0
BA b	0	-Fb+Fx	0	0	0	0
BC b	-x/b	Fb+1/2Fx	-Fx-1/2Fx ² /b	x ² /b ²	-2/3Fb ² /EJ	1/3Xb/EJ
CB b	1-x/b	-3/2Fb+1/2Fx	-3/2Fb+2Fx-1/2Fx ² /b	1-2x/b+x ² /b ²	1/12Fb ² /EJ	1/3Xb/EJ
CD b	-1	5/2Fb-5/2Fx	-5/2Fb+5/2Fx	1	-5/4Fb ² /EJ	Xb/EJ
DC b	1	-5/2Fx	-5/2Fx	1	0	0
DE b	-1+x/b	-1/2Fx	1/2Fx-1/2Fx ² /b	1-2x/b+x ² /b ²	1/12Fb ² /EJ	1/3Xb/EJ
ED b	x/b	1/2Fb-1/2Fx	1/2Fx-1/2Fx ² /b	x ² /b ²	0	0
EF √5b	0	7√5/10Fx+1/2qx ²	0	0	0	0
FG b	0	-2Fx	0	0	0	0
GF b	0	2Fb-2Fx	0	0	0	0
GA 2b	0	-Fb	0	0	0	0
AG 2b	0	Fb	0	0	0	0
FB 2b	0	6Fb-3Fx	0	0	0	0
BF 2b	0	-3Fx	0	0	0	0
BE b	0	Fx-1/2qx ²	0	0	0	0
EB b	0	-1/2Fb+1/2qx ²	0	0	0	0
BE	elongazione asta N _{1BE} ε _{BE} L _{BE}				Fb ² /EJ	
	totali				-5/6Fb ² /EJ	5/3Xb/EJ
	iperstatica X=W _{DE}				1/2Fb	

Sviluppi di calcolo iperstatica

$$L_{BC}^{xx} = \int_0^b (x^2/b^2) 1/EJ dx = [1/3 x^3/b^2]_0^b 1/EJ = (1/3 b) 1/EJ = 1/3 b/EJ$$

$$L_{CB}^{xx} = \int_0^b (1 - 2x/b + x^2/b^2) 1/EJ dx = [x - x^2/b + 1/3 x^3/b^2]_0^b 1/EJ = (b - b + 1/3 b) 1/EJ = 1/3 b/EJ$$

$$L_{CD}^{xx} = \int_0^b (1) 1/EJ dx = [x]_0^b 1/EJ = (b) 1/EJ = b/EJ$$

$$L_{DC}^{xx} = \int_0^b (1) 1/EJ dx = [x]_0^b 1/EJ = (b) 1/EJ = b/EJ$$

$$L_{DE}^{xx} = \int_0^b (1 - 2x/b + x^2/b^2) 1/EJ dx = [x - x^2/b + 1/3 x^3/b^2]_0^b 1/EJ = (b - b + 1/3 b) 1/EJ = 1/3 b/EJ$$

$$L_{ED}^{xx} = \int_0^b (x^2/b^2) 1/EJ dx = [1/3 x^3/b^2]_0^b 1/EJ = (1/3 b) 1/EJ = 1/3 b/EJ$$

$$L_{BC}^{xo} = \int_0^b (-x/b - 1/2 x^2/b^2) Fb 1/EJ dx = [-1/2 x^2/b - 1/6 x^3/b^2]_0^b Fb 1/EJ = (-1/2 b - 1/6 b) Fb 1/EJ = -2/3 Fb^2/EJ$$

$$L_{CB}^{xo} = \int_0^b (-3/2 + 2x/b - 1/2 x^2/b^2) Fb 1/EJ dx = [-3/2 x + x^2/b - 1/6 x^3/b^2]_0^b Fb 1/EJ = (-3/2 b + b - 1/6 b) Fb 1/EJ = -2/3 Fb^2/EJ$$

$$L_{CD}^{xo} = \int_0^b (-5/2 + 5/2 x/b) Fb 1/EJ dx = [-5/2 x + 5/4 x^2/b]_0^b Fb 1/EJ = (-5/2 b + 5/4 b) Fb 1/EJ = -5/4 Fb^2/EJ$$

$$L_{DC}^{xo} = \int_0^b (-5/2 x/b) Fb 1/EJ dx = [-5/4 x^2/b]_0^b Fb 1/EJ = (-5/4 b) Fb 1/EJ = -5/4 Fb^2/EJ$$

$$L_{DE}^{xo} = \int_0^b (1/2 x/b - 1/2 x^2/b^2) Fb 1/EJ dx = [1/4 x^2/b - 1/6 x^3/b^2]_0^b Fb 1/EJ = (1/4 b - 1/6 b) Fb 1/EJ = 1/12 Fb^2/EJ$$

$$L_{ED}^{xo} = \int_0^b (1/2 x/b - 1/2 x^2/b^2) Fb 1/EJ dx = [1/4 x^2/b - 1/6 x^3/b^2]_0^b Fb 1/EJ = (1/4 b - 1/6 b) Fb 1/EJ = 1/12 Fb^2/EJ$$

- $H_{FB} = -F$
- $V_D = -F$
- $W_C = -W = -Fb$
- $W_G = -W = -Fb$
- $W_A = -W = -Fb$
- $q_{CD} = -q = -F/b$
- $p_{FB} = -q = -F/b$
- $\epsilon_{CD} = -\alpha T = -b^2 F/EJ$
- $k_C = 4EJ/b^3$
- $EJ_{AB} = EJ$
- $EJ_{BC} = EJ$
- $EJ_{CD} = EJ$
- $EJ_{DE} = EJ$
- $EJ_{EF} = EJ$
- $EJ_{FG} = EJ$
- $EJ_{GA} = EJ$
- $EJ_{FB} = EJ$
- $EJ_{BE} = EJ$

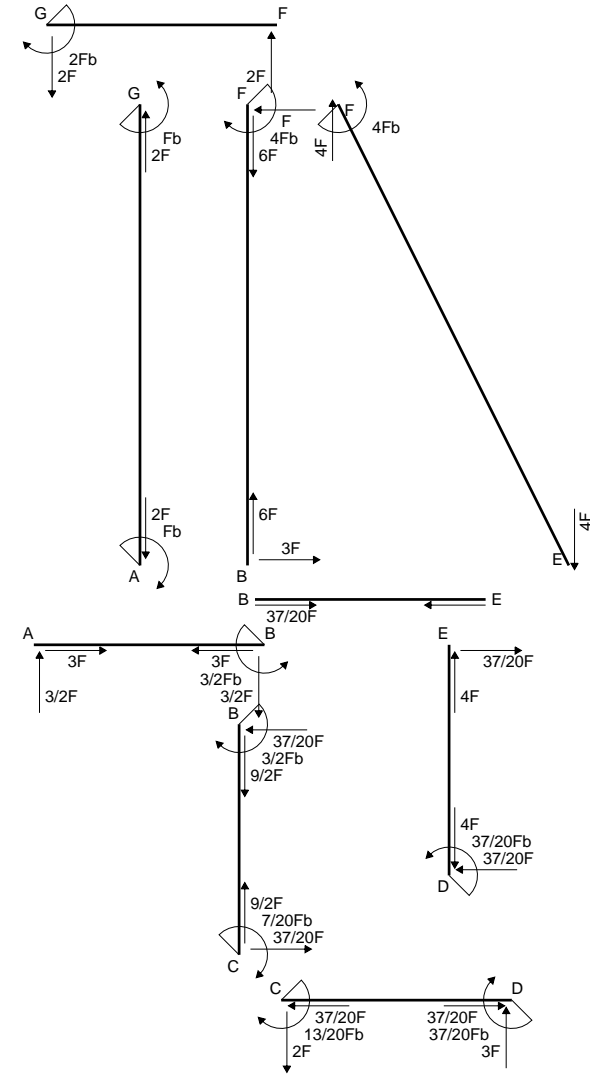
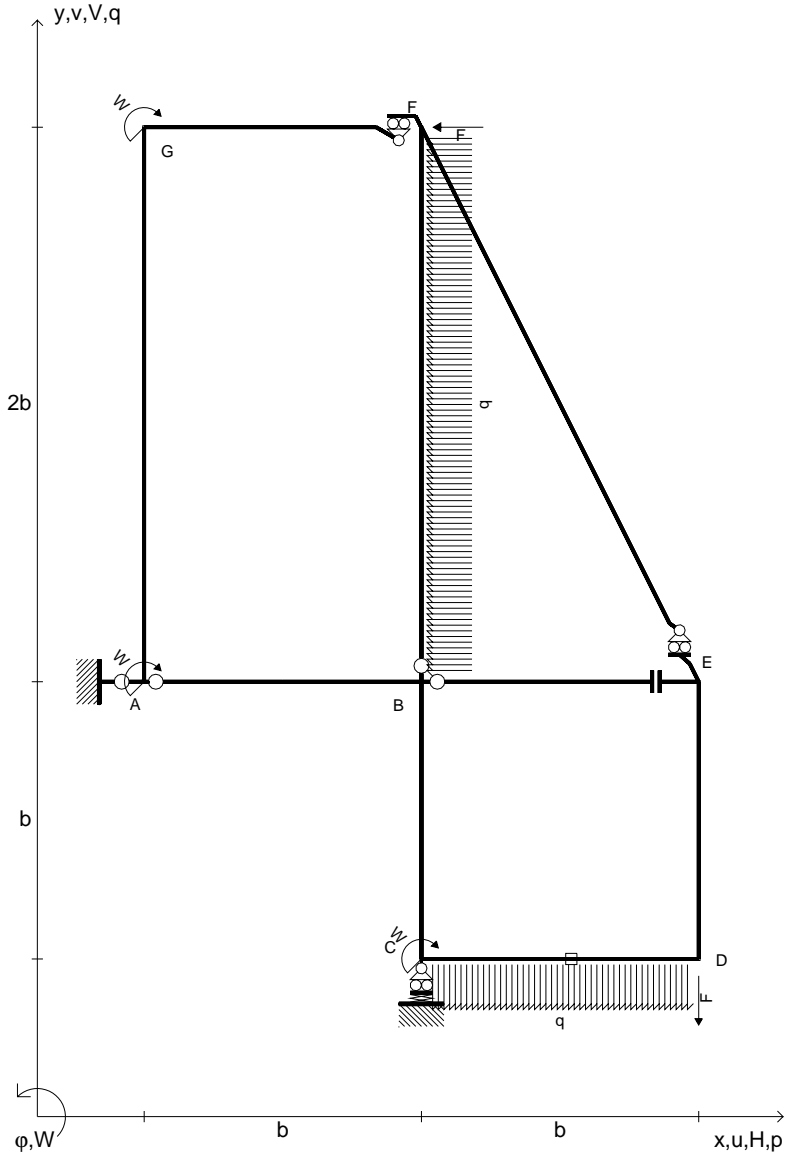

Reazioni iperstatiche in soluzione: $X=W_{DC}$
 Carichi e deformazioni date hanno verso efficace in disegno.
 Calcolare reazioni vincolari della struttura e delle aste.
 Tracciare i diagrammi quotati delle azioni interne nelle aste.
 $J_{YZ} - x_{YZ} - \theta_{YZ}$ riferimento locale asta YZ con origine in Y.
 Elongazione termica specifica ϵ assegnata su asta CD.
 © Adolfo Zavelani Rossi, Politecnico di Milano, vers.27.03.13

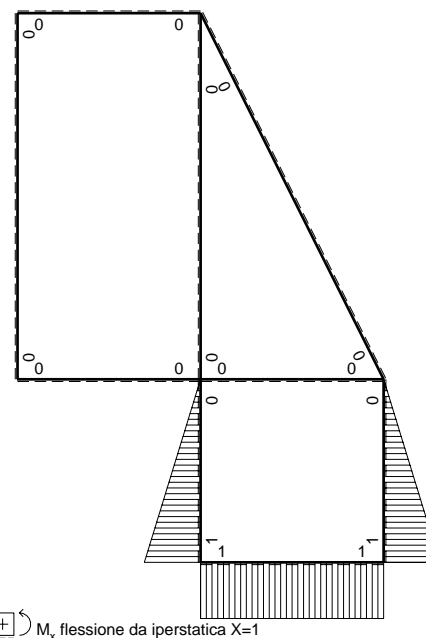
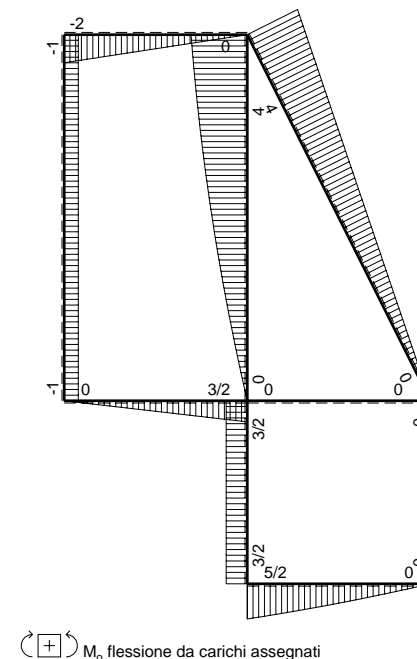
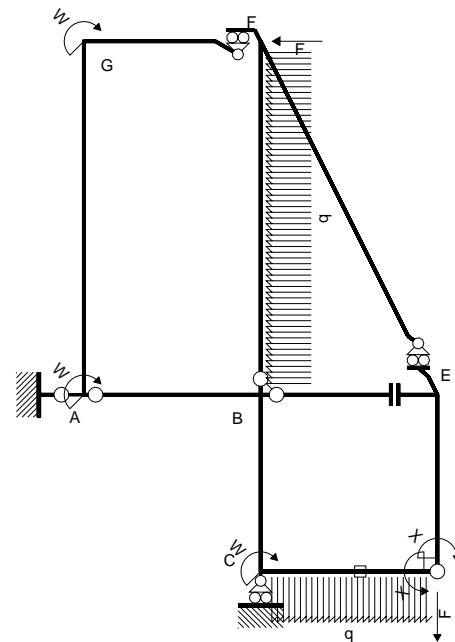
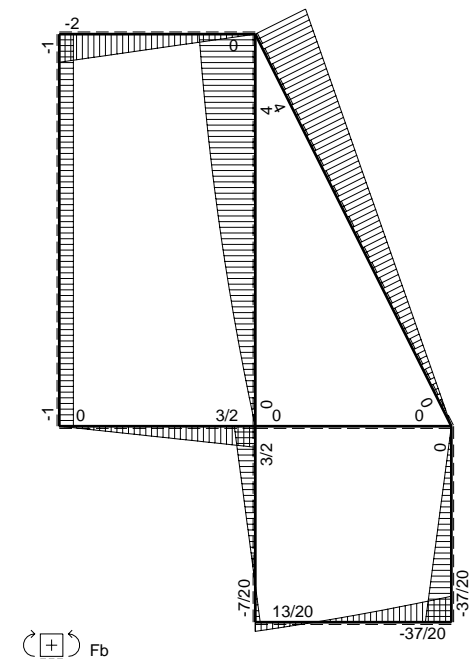
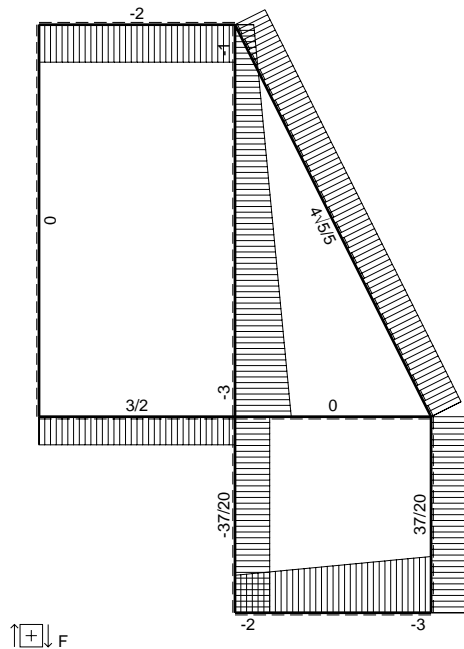
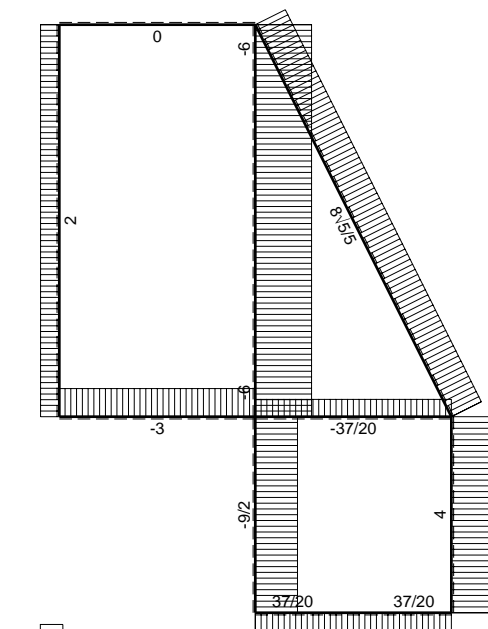

Quadro contributi PLV per iperstatica $X=W_{DC}$

→	$M_x(x)$	$M_o(x)$	$M_x M_o$	$M_x M_x$	$\int M_x M_o / EJ dx$	$\int X M_x M_x / EJ dx$
AB b	0	3/2Fx	0	0	0	0
BA b	0	-3/2Fb+3/2Fx	0	0	0	0
BC b	x/b	3/2Fb	3/2Fx	x^2/b^2	3/4Fb ² /EJ	1/3Xb/EJ
CB b	-1+x/b	-3/2Fb	3/2Fb-3/2Fx	$1-2x/b+x^2/b^2$	3/4Fb ² /EJ	1/3Xb/EJ
CD b	1	5/2Fb-2Fx-1/2qx ²	5/2Fb-2Fx-1/2Fx ² /b	1	4/3Fb ² /EJ	Xb/EJ
DC b	-1	-3Fx+1/2qx ²	3Fx-1/2Fx ² /b	1	4/3Fb ² /EJ	Xb/EJ
DE b	1-x/b	0	0	$1-2x/b+x^2/b^2$	0	1/3Xb/EJ
ED b	-x/b	0	0	x^2/b^2	0	1/3Xb/EJ
EF √5b	0	4√5/5Fx	0	0	0	0
FG b	0	-2Fx	0	0	0	0
GF b	0	2Fb-2Fx	0	0	0	0
GA 2b	0	-Fb	0	0	0	0
AG 2b	0	Fb	0	0	0	0
FB 2b	0	4Fb-Fx-1/2qx ²	0	0	0	0
BF 2b	0	-3Fx+1/2qx ²	0	0	0	0
BE b	0	0	0	0	0	0
EB b	0	0	0	0	0	0
CD	elongazione asta $N_{1CD} \epsilon_{CD} L_{CD}$				Fb ² /EJ	
	totali				37/12Fb ² /EJ	5/3Xb/EJ
	iperstatica $X=W_{DC}$				-37/20Fb	

Sviluppi di calcolo iperstatica

$$L_{BC}^{xx} = \int_0^b (x^2/b^2) 1/EJ dx = [1/3 x^3/b^2]_0^b 1/EJ$$

$$= (1/3 b) 1/EJ = 1/3 b/EJ$$

$$L_{CB}^{xx} = \int_0^b (1 - 2x/b + x^2/b^2) 1/EJ dx = [x - x^2/b + 1/3 x^3/b^2]_0^b 1/EJ$$

$$= (b - b + 1/3 b) 1/EJ = 1/3 b/EJ$$

$$L_{CD}^{xx} = \int_0^b (1) 1/EJ dx = [x]_0^b 1/EJ$$

$$= (b) 1/EJ = b/EJ$$

$$L_{DC}^{xx} = \int_0^b (1) 1/EJ dx = [x]_0^b 1/EJ$$

$$= (b) 1/EJ = b/EJ$$

$$L_{DE}^{xx} = \int_0^b (1 - 2x/b + x^2/b^2) 1/EJ dx = [x - x^2/b + 1/3 x^3/b^2]_0^b 1/EJ$$

$$= (b - b + 1/3 b) 1/EJ = 1/3 b/EJ$$

$$L_{ED}^{xx} = \int_0^b (x^2/b^2) 1/EJ dx = [1/3 x^3/b^2]_0^b 1/EJ$$

$$= (1/3 b) 1/EJ = 1/3 b/EJ$$

$$L_{BC}^{xo} = \int_0^b (3/2 x/b) Fb 1/EJ dx = [3/4 x^2/b]_0^b Fb 1/EJ$$

$$= (3/4 b) Fb 1/EJ = 3/4 Fb^2/EJ$$

$$L_{CB}^{xo} = \int_0^b (3/2 - 3/2 x/b) Fb 1/EJ dx = [3/2 x - 3/4 x^2/b]_0^b Fb 1/EJ$$

$$= (3/2 b - 3/4 b) Fb 1/EJ = 3/4 Fb^2/EJ$$

$$L_{CD}^{xo} = \int_0^b (5/2 - 2x/b - 1/2 x^2/b^2) Fb 1/EJ dx - 1 (-1) 1 Fb^2/EJ$$

$$= [5/2 x - x^2/b - 1/6 x^3/b^2]_0^b Fb 1/EJ - 1 (-1) 1 Fb^2/EJ$$

$$= (5/2 b - b - 1/6 b) Fb 1/EJ - 1 (-1) 1 Fb^2/EJ = 7/3 Fb^2/EJ$$

$$L_{DC}^{xo} = \int_0^b (3x/b - 1/2 x^2/b^2) Fb 1/EJ dx - 1 (-1) 1 Fb^2/EJ$$

$$= [3/2 x^2/b - 1/6 x^3/b^2]_0^b Fb 1/EJ - 1 (-1) 1 Fb^2/EJ$$

$$= (3/2 b - 1/6 b) Fb 1/EJ - 1 (-1) 1 Fb^2/EJ = 7/3 Fb^2/EJ$$

Quadro contributi PLV per iperstatica X=W_{DC}

→	M _x (x)	M _o (x)	M _x M _o	M _x M _x	∫M _x M _o /EJdx	∫XM _x M _x /EJdx
AB b	0	-1/2qx ²	0	0	0	0
BA b	0	1/2Fb-Fx+1/2qx ²	0	0	0	0
BC b	x/b	-1/2Fb+1/2Fx	-1/2Fx+1/2Fx ² /b	x ² /b ²	-1/12Fb ² /EJ	1/3Xb/EJ
CB b	-1+x/b	1/2Fx	-1/2Fx+1/2Fx ² /b	1-2x/b+x ² /b ²	-1/12Fb ² /EJ	1/3Xb/EJ
CD b	1	Fb-Fx	Fb-Fx	1	1/2Fb ² /EJ	Xb/EJ
DC b	-1	-Fx	Fx	1	1/2Fb ² /EJ	Xb/EJ
DE b	1-x/b	-1/2Fx	-1/2Fx+1/2Fx ² /b	1-2x/b+x ² /b ²	-1/12Fb ² /EJ	1/3Xb/EJ
ED b	-x/b	1/2Fb-1/2Fx	-1/2Fx+1/2Fx ² /b	x ² /b ²	-1/12Fb ² /EJ	1/3Xb/EJ
EF √5b	0	2√5/5Fx	0	0	0	0
FG b	0	-2Fx	0	0	0	0
GF b	0	2Fb-2Fx	0	0	0	0
GA 2b	0	-Fb	0	0	0	0
AG 2b	0	Fb	0	0	0	0
FB 2b	0	2Fb-Fx	0	0	0	0
BF 2b	0	-Fx	0	0	0	0
BE b	0	Fx-1/2qx ²	0	0	0	0
EB b	0	-1/2Fb+1/2qx ²	0	0	0	0
BE	elongazione asta N _{1BE} ε _{BE} L _{BE}				-Fb ² /EJ	
	totali				-2/3Fb ² /EJ	5/3Xb/EJ
	iperstatica X=W _{DC}				2/5Fb	

Sviluppi di calcolo iperstatica

$$L_{BC}^{xx} = \int_0^b (x^2/b^2) 1/EJ dx = [1/3 x^3/b^2]_0^b 1/EJ = (1/3 b) 1/EJ = 1/3 b/EJ$$

$$L_{CB}^{xx} = \int_0^b (1 - 2x/b + x^2/b^2) 1/EJ dx = [x - x^2/b + 1/3 x^3/b^2]_0^b 1/EJ = (b - b + 1/3 b) 1/EJ = 1/3 b/EJ$$

$$L_{CD}^{xx} = \int_0^b (1) 1/EJ dx = [x]_0^b 1/EJ = (b) 1/EJ = b/EJ$$

$$L_{DC}^{xx} = \int_0^b (1) 1/EJ dx = [x]_0^b 1/EJ = (b) 1/EJ = b/EJ$$

$$L_{DE}^{xx} = \int_0^b (1 - 2x/b + x^2/b^2) 1/EJ dx = [x - x^2/b + 1/3 x^3/b^2]_0^b 1/EJ = (b - b + 1/3 b) 1/EJ = 1/3 b/EJ$$

$$L_{ED}^{xx} = \int_0^b (x^2/b^2) 1/EJ dx = [1/3 x^3/b^2]_0^b 1/EJ = (1/3 b) 1/EJ = 1/3 b/EJ$$

$$L_{BC}^{xo} = \int_0^b (-1/2 x/b + 1/2 x^2/b^2) Fb 1/EJ dx = [-1/4 x^2/b + 1/6 x^3/b^2]_0^b Fb 1/EJ = (-1/4 b + 1/6 b) Fb 1/EJ = -1/12 Fb²/EJ$$

$$L_{CB}^{xo} = \int_0^b (-1/2 x/b + 1/2 x^2/b^2) Fb 1/EJ dx = [-1/4 x^2/b + 1/6 x^3/b^2]_0^b Fb 1/EJ = (-1/4 b + 1/6 b) Fb 1/EJ = -1/12 Fb²/EJ$$

$$L_{CD}^{xo} = \int_0^b (1 - x/b) Fb 1/EJ dx = [x - 1/2 x^2/b]_0^b Fb 1/EJ = (b - 1/2 b) Fb 1/EJ = 1/2 Fb²/EJ$$

$$L_{DC}^{xo} = \int_0^b (x/b) Fb 1/EJ dx = [1/2 x^2/b]_0^b Fb 1/EJ = (1/2 b) Fb 1/EJ = 1/2 Fb²/EJ$$

$$L_{DE}^{xo} = \int_0^b (-1/2 x/b + 1/2 x^2/b^2) Fb 1/EJ dx = [-1/4 x^2/b + 1/6 x^3/b^2]_0^b Fb 1/EJ = (-1/4 b + 1/6 b) Fb 1/EJ = -1/12 Fb²/EJ$$

$$L_{ED}^{xo} = \int_0^b (-1/2 x/b + 1/2 x^2/b^2) Fb 1/EJ dx = [-1/4 x^2/b + 1/6 x^3/b^2]_0^b Fb 1/EJ = (-1/4 b + 1/6 b) Fb 1/EJ = -1/12 Fb²/EJ$$

- $H_{FB} = -F$
- $V_D = -F$
- $W_C = -W = -Fb$
- $W_G = -W = -Fb$
- $W_A = -W = -Fb$
- $q_{AB} = -q = -F/b$
- $p_{DE} = -q = -F/b$
- $\epsilon_{BE} = -\alpha T = -b^2 F/EJ$
- $k_C = 4EJ/b^3$
- $EJ_{AB} = EJ$
- $EJ_{BC} = EJ$
- $EJ_{CD} = EJ$
- $EJ_{DE} = EJ$
- $EJ_{EF} = EJ$
- $EJ_{FG} = EJ$
- $EJ_{GA} = EJ$
- $EJ_{FB} = EJ$
- $EJ_{BE} = EJ$

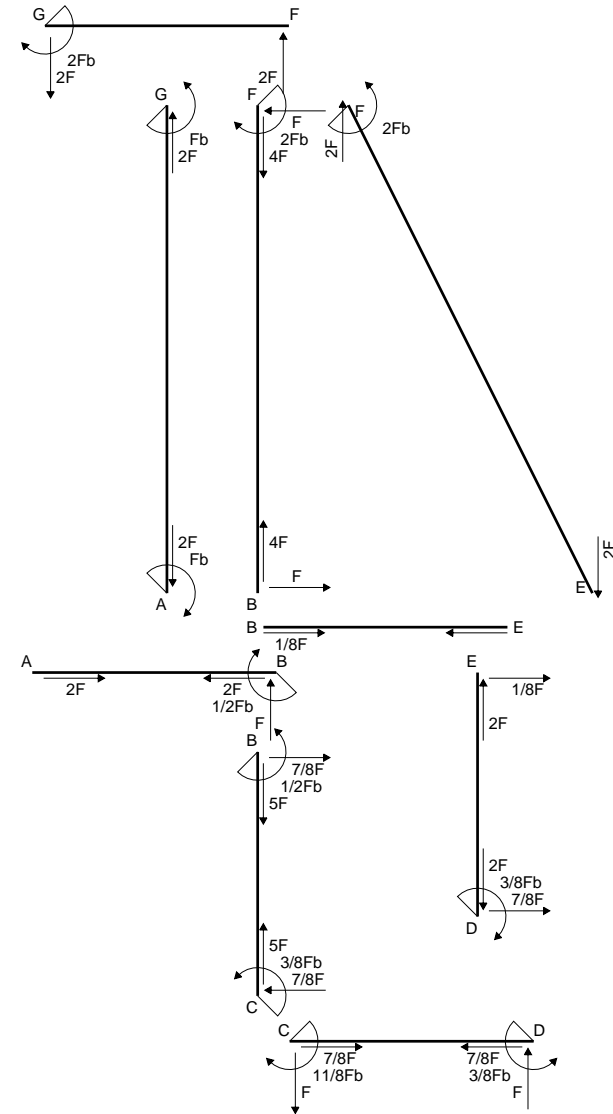
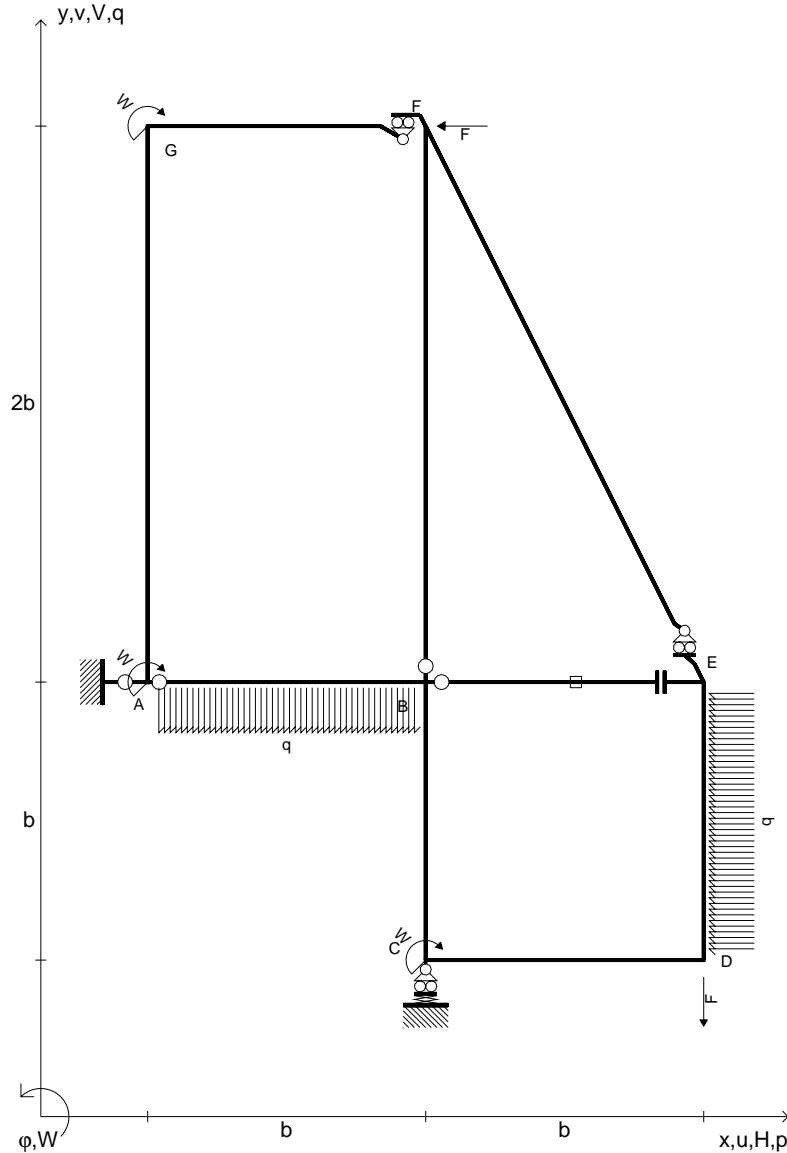

Reazioni iperstatiche in soluzione: $X=H_{BE}$
 Carichi e deformazioni date hanno verso efficace in disegno.
 Calcolare reazioni vincolari della struttura e delle aste.
 Tracciare i diagrammi quotati delle azioni interne nelle aste.
 $J_{YZ} - x_{YZ} - \theta_{YZ}$ riferimento locale asta YZ con origine in Y.
 Elongazione termica specifica ϵ assegnata su asta BE.
 © Adolfo Zavelani Rossi, Politecnico di Milano, vers.27.03.13

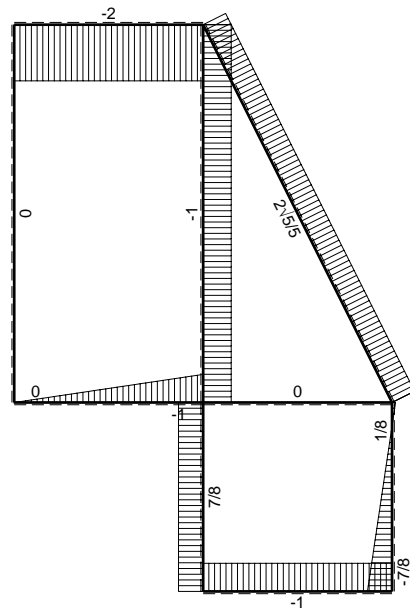
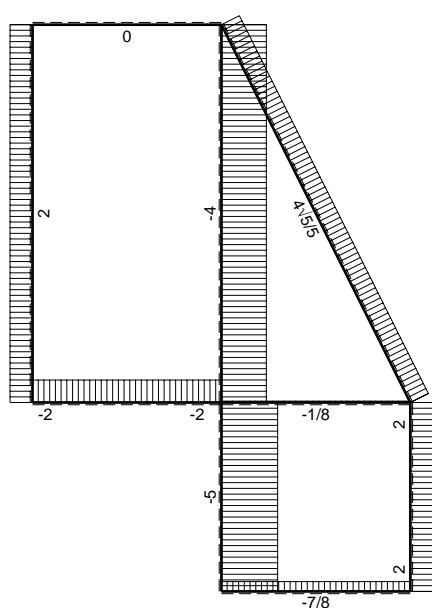

← (+) → F

↑ (+) ↓ F

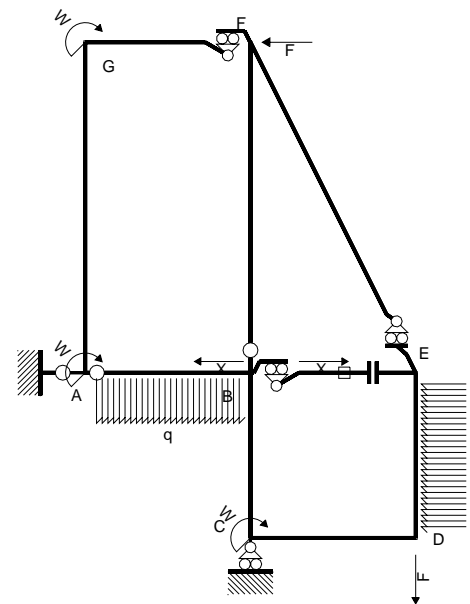

Schema di calcolo iperstatico

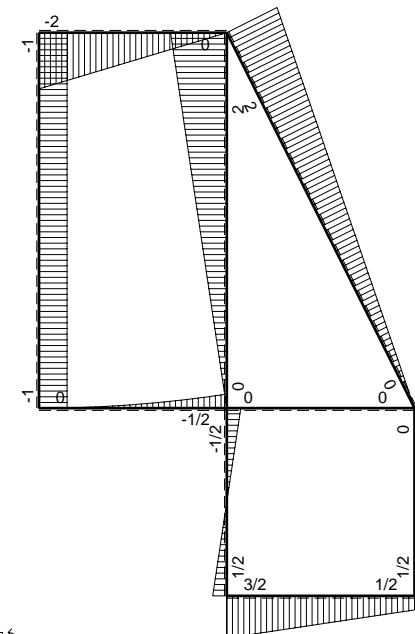

⊕ M₀ flessione da carichi assegnati

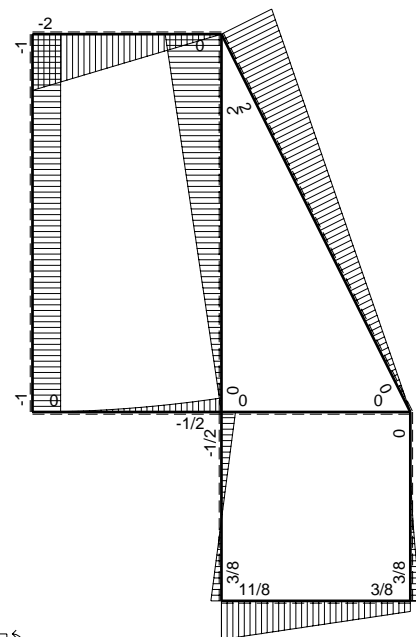

⊕ F_b

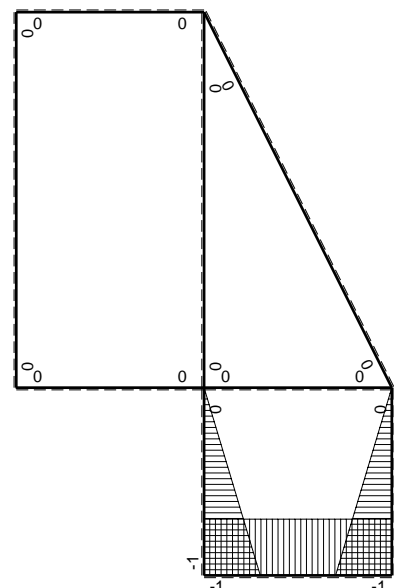

⊕ M_x flessione da iperstatica X=1

Quadro contributi PLV per iperstatica $X=H_{BE}$

→	$M_x(x)$	$M_o(x)$	$M_x M_o$	$M_x M_x$	$\int M_x M_o / EJ dx$	$\int X M_x M_x / EJ dx$
AB b	0	$-1/2qx^2$	0	0	0	0
BA b	0	$1/2Fb-Fx+1/2qx^2$	0	0		
BC b	-x	$-1/2Fb+Fx$	$1/2Fbx-Fx^2$	x^2	$-1/12Fb^3/EJ$	$1/3Xb^3/EJ$
CB b	b-x	$-1/2Fb+Fx$	$-1/2Fb^2+3/2Fbx-Fx^2$	$b^2-2bx+x^2$		
CD b	-b	$3/2Fb-Fx$	$-3/2Fb^2+Fbx$	b^2	$-Fb^3/EJ$	Xb^3/EJ
DC b	b	$-1/2Fb-Fx$	$-1/2Fb^2-Fbx$	b^2		
DE b	-b+x	$1/2Fb-Fx+1/2qx^2$	$-1/2Fb^2+3/2Fbx-3/2Fx^2+1/2qx^3$	$b^2-2bx+x^2$	$-1/8Fb^3/EJ$	$1/3Xb^3/EJ$
ED b	x	$-1/2qx^2$	$-1/2qx^3$	x^2		
EF $\sqrt{5}b$	0	$2\sqrt{5}/5Fx$	0	0	0	0
FG b	0	$-2Fx$	0	0	0	0
GF b	0	$2Fb-2Fx$	0	0		
GA 2b	0	$-Fb$	0	0	0	0
AG 2b	0	Fb	0	0		
FB 2b	0	$2Fb-Fx$	0	0	0	0
BF 2b	0	$-Fx$	0	0		
BE b	0	0	0	0	0	0
EB b	0	0	0	0	0	0
BE	elongazione asta $N_{1BE} \epsilon_{BE} L_{BE}$				Fb^3/EJ	
	totali				$-5/24Fb^3/EJ$	$5/3Xb^3/EJ$
	iperstatica $X=H_{BE}$				$1/8F$	

Sviluppi di calcolo iperstatica

$$L_{BC}^{xx} = \int_0^b (x^2/b^2) b^2 1/EJ dx = [1/3 x^3/b^2]_0^b b^2 1/EJ$$

$$= (1/3 b) b^2 1/EJ = 1/3 b^3/EJ$$

$$L_{CB}^{xx} = \int_0^b (1 - 2x/b + x^2/b^2) b^2 1/EJ dx = [x - x^2/b + 1/3 x^3/b^2]_0^b b^2 1/EJ$$

$$= (b - b + 1/3 b) b^2 1/EJ = 1/3 b^3/EJ$$

$$L_{CD}^{xx} = \int_0^b (1) b^2 1/EJ dx = [x]_0^b b^2 1/EJ$$

$$= (b) b^2 1/EJ = b^3/EJ$$

$$L_{DC}^{xx} = \int_0^b (1) b^2 1/EJ dx = [x]_0^b b^2 1/EJ$$

$$= (b) b^2 1/EJ = b^3/EJ$$

$$L_{DE}^{xx} = \int_0^b (1 - 2x/b + x^2/b^2) b^2 1/EJ dx = [x - x^2/b + 1/3 x^3/b^2]_0^b b^2 1/EJ$$

$$= (b - b + 1/3 b) b^2 1/EJ = 1/3 b^3/EJ$$

$$L_{ED}^{xx} = \int_0^b (x^2/b^2) b^2 1/EJ dx = [1/3 x^3/b^2]_0^b b^2 1/EJ$$

$$= (1/3 b) b^2 1/EJ = 1/3 b^3/EJ$$

$$L_{BC}^{xo} = \int_0^b (1/2 x/b - x^2/b^2) Fb^2 1/EJ dx = [1/4 x^2/b - 1/3 x^3/b^2]_0^b Fb^2 1/EJ$$

$$= (1/4 b - 1/3 b) Fb^2 1/EJ = -1/12 Fb^3/EJ$$

$$L_{CB}^{xo} = \int_0^b (-1/2 + 3/2 x/b - x^2/b^2) Fb^2 1/EJ dx = [-1/2 x + 3/4 x^2/b - 1/3 x^3/b^2]_0^b Fb^2 1/EJ$$

$$= (-1/2 b + 3/4 b - 1/3 b) Fb^2 1/EJ = -1/12 Fb^3/EJ$$

$$L_{CD}^{xo} = \int_0^b (-3/2 + x/b) Fb^2 1/EJ dx = [-3/2 x + 1/2 x^2/b]_0^b Fb^2 1/EJ$$

$$= (-3/2 b + 1/2 b) Fb^2 1/EJ = - Fb^3/EJ$$

$$L_{DC}^{xo} = \int_0^b (-1/2 - x/b) Fb^2 1/EJ dx = [-1/2 x - 1/2 x^2/b]_0^b Fb^2 1/EJ$$

$$= (-1/2 b - 1/2 b) Fb^2 1/EJ = - Fb^3/EJ$$

$$L_{DE}^{xo} = \int_0^b (-1/2 + 3/2 x/b - 3/2 x^2/b^2 + 1/2 x^3/b^3) Fb^2 1/EJ dx$$

$$= [-1/2 x + 3/4 x^2/b - 1/2 x^3/b^2 + 1/8 x^4/b^3]_0^b Fb^2 1/EJ$$

$$= (-1/2 b + 3/4 b - 1/2 b + 1/8 b) Fb^2 1/EJ = -1/8 Fb^3/EJ$$

$$L_{ED}^{xo} = \int_0^b (-1/2 x^3/b^3) Fb^2 1/EJ dx = [-1/8 x^4/b^3]_0^b Fb^2 1/EJ$$

$$= (-1/8 b) Fb^2 1/EJ = -1/8 Fb^3/EJ$$

- $H_{FB} = -F$
- $V_D = -F$
- $W_C = -W = -Fb$
- $W_G = -W = -Fb$
- $W_A = -W = -Fb$
- $p_{FB} = -q = -F/b$
- $p_{EF} = -q = -F/b$
- $q_{EF} = -q = -F/b$
- $\epsilon_{CD} = -\alpha T = -b^2 F/EJ$
- $k_C = 4EJ/b^3$
- $EJ_{AB} = EJ$
- $EJ_{BC} = EJ$
- $EJ_{CD} = EJ$
- $EJ_{DE} = EJ$
- $EJ_{EF} = EJ$
- $EJ_{FG} = EJ$
- $EJ_{GA} = EJ$
- $EJ_{FB} = EJ$
- $EJ_{BE} = EJ$

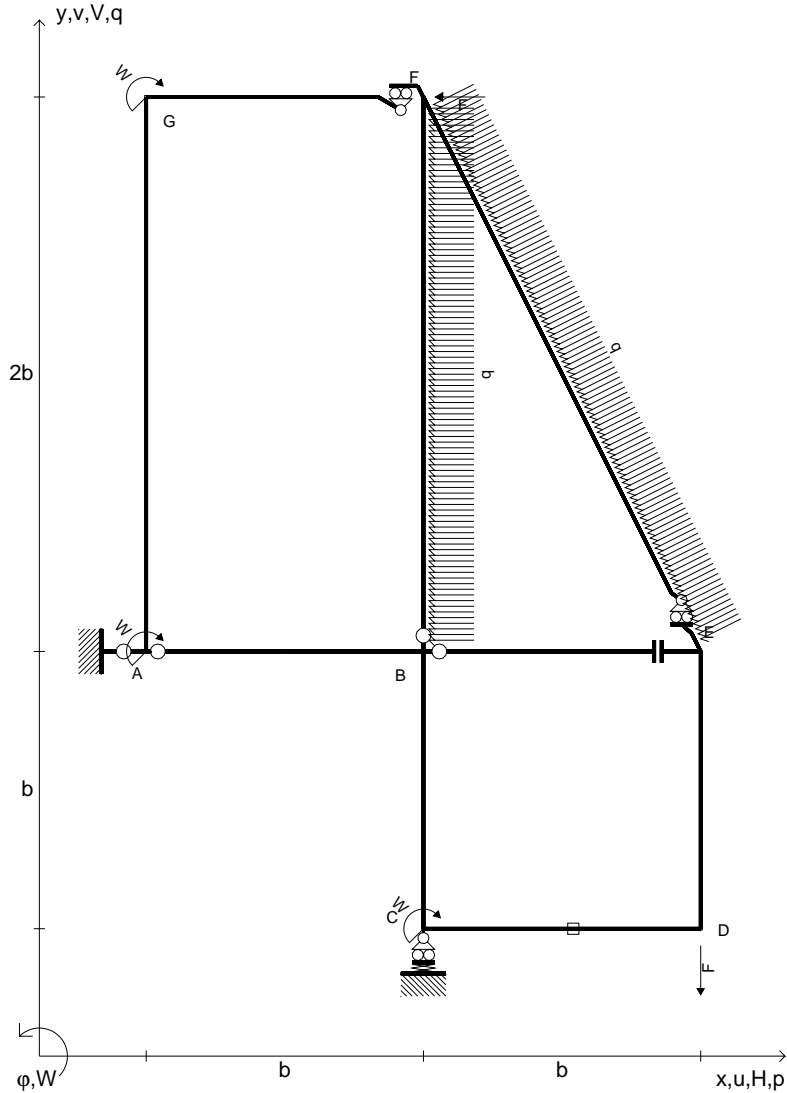

Reazioni iperstatiche in soluzione: $X=H_{BE}$
 Carichi e deformazioni date hanno verso efficace in disegno.
 Calcolare reazioni vincolari della struttura e delle aste.
 Tracciare i diagrammi quotati delle azioni interne nelle aste.
 Diagrammi di carico con valori riferiti ad asse della trave.
 Componenti di carico distribuito riferiti ad assi ortogonali.
 $J_{YZ} - x_{YZ} - \theta_{YZ}$ riferimento locale asta YZ con origine in Y.
 Elongazione termica specifica ϵ assegnata su asta CD.
 © Adolfo Zavelani Rossi, Politecnico di Milano, vers.27.03.13

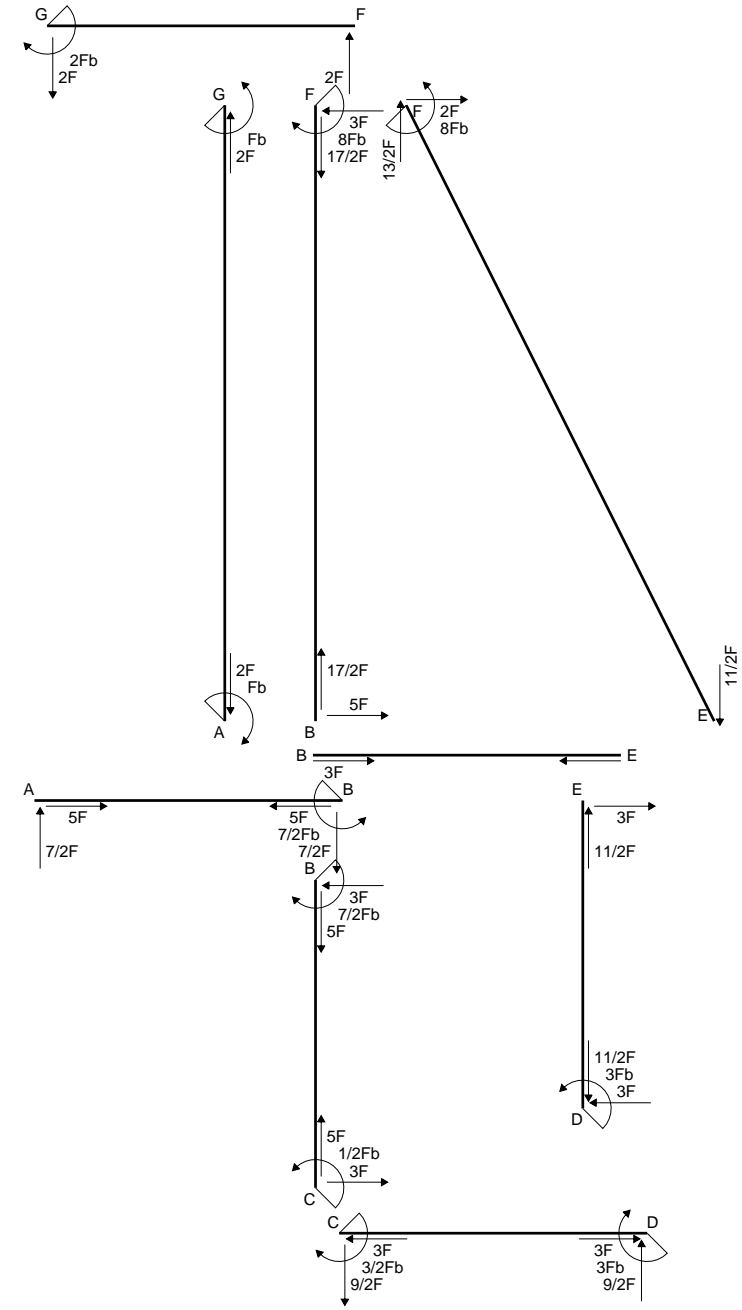

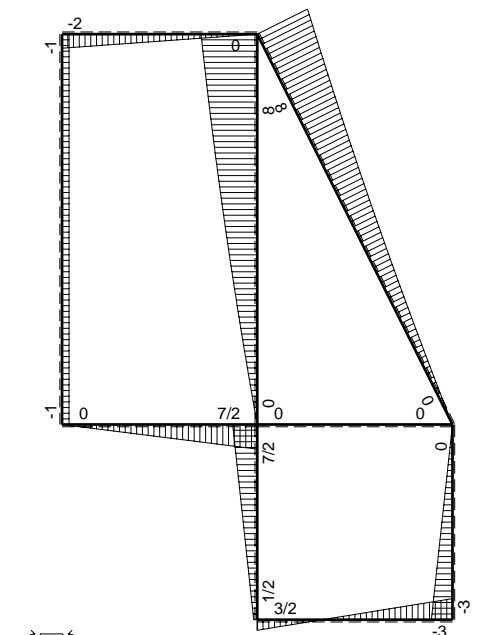
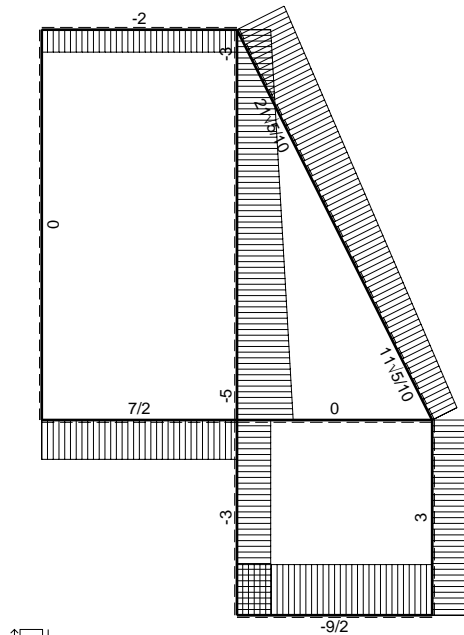
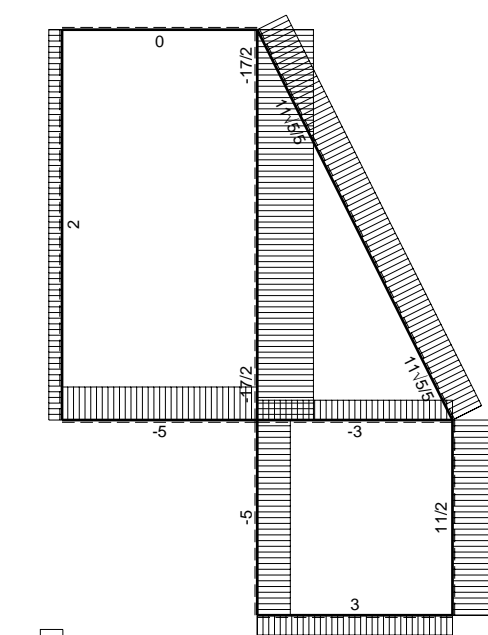

\oplus F_b

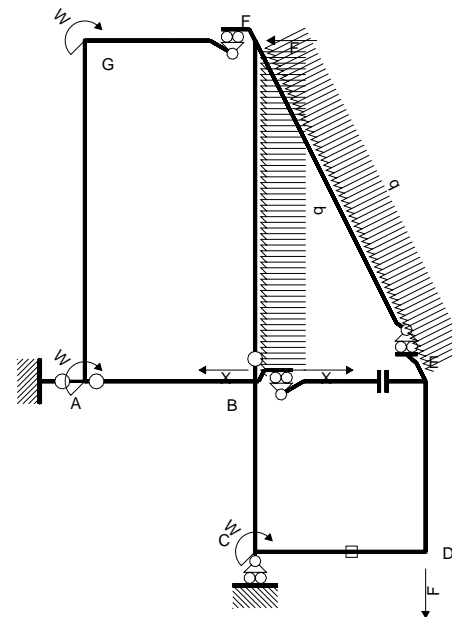

Schema di calcolo iperstatico

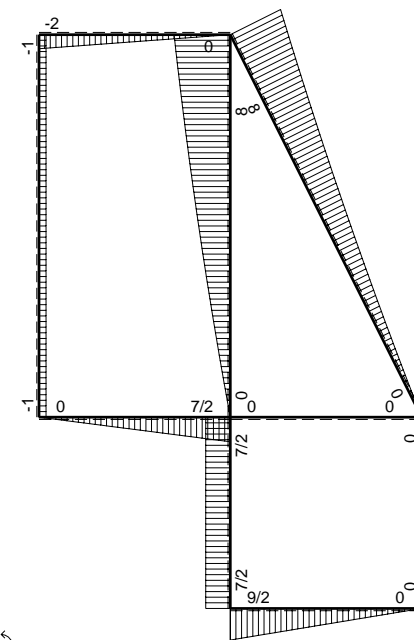

\oplus M₀ flessione da carichi assegnati

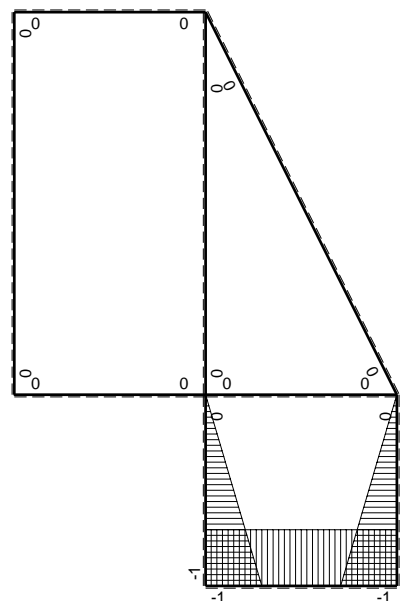

\oplus M_x flessione da iperstatica X=1

Quadro contributi PLV per iperstatica X=H_{BE}

→	M _x (x)	M _o (x)	M _x M _o	M _x M _x	∫M _x M _o /EJdx	∫XM _x M _x /EJdx
AB b	0	7/2Fx	0	0	0	0
BA b	0	-7/2Fb+7/2Fx	0	0	0	0
BC b	-x	7/2Fb	-7/2Fbx	x ²	-7/4Fb ³ /EJ	1/3Xb ³ /EJ
CB b	b-x	-7/2Fb	-7/2Fb ² +7/2Fbx	b ² -2bx+x ²	-7/4Fb ³ /EJ	1/3Xb ³ /EJ
CD b	-b	9/2Fb-9/2Fx	-9/2Fb ² +9/2Fbx	b ²	-9/4Fb ³ /EJ	Xb ³ /EJ
DC b	b	-9/2Fx	-9/2Fbx	b ²	-9/4Fb ³ /EJ	Xb ³ /EJ
DE b	-b+x	0	0	b ² -2bx+x ²	0	1/3Xb ³ /EJ
ED b	x	0	0	x ²	0	1/3Xb ³ /EJ
EF √5b	0	11√5/10Fx+1/2qx ²	0	0	0	0
FG b	0	-2Fx	0	0	0	0
GF b	0	2Fb-2Fx	0	0	0	0
GA 2b	0	-Fb	0	0	0	0
AG 2b	0	Fb	0	0	0	0
FB 2b	0	8Fb-3Fx-1/2qx ²	0	0	0	0
BF 2b	0	-5Fx+1/2qx ²	0	0	0	0
BE b	0	0	0	0	0	0
EB b	0	0	0	0	0	0
CD	elongazione asta N _{1CD} ε _{CD} L _{CD}				-Fb ³ /EJ	
	totali				-5Fb ³ /EJ	5/3Xb ³ /EJ
	iperstatica X=H _{BE}				3F	

Sviluppi di calcolo iperstatica

$$L_{BC}^{XX} = \int_0^b (x^2/b^2) b^2 1/EJ dx = [1/3 x^3/b^2]_0^b b^2 1/EJ$$

$$= (1/3 b) b^2 1/EJ = 1/3 b^3/EJ$$

$$L_{CB}^{XX} = \int_0^b (1 - 2x/b + x^2/b^2) b^2 1/EJ dx = [x - x^2/b + 1/3 x^3/b^2]_0^b b^2 1/EJ$$

$$= (b - b + 1/3 b) b^2 1/EJ = 1/3 b^3/EJ$$

$$L_{CD}^{XX} = \int_0^b (1) b^2 1/EJ dx = [x]_0^b b^2 1/EJ$$

$$= (b) b^2 1/EJ = b^3/EJ$$

$$L_{DC}^{XX} = \int_0^b (1) b^2 1/EJ dx = [x]_0^b b^2 1/EJ$$

$$= (b) b^2 1/EJ = b^3/EJ$$

$$L_{DE}^{XX} = \int_0^b (1 - 2x/b + x^2/b^2) b^2 1/EJ dx = [x - x^2/b + 1/3 x^3/b^2]_0^b b^2 1/EJ$$

$$= (b - b + 1/3 b) b^2 1/EJ = 1/3 b^3/EJ$$

$$L_{ED}^{XX} = \int_0^b (x^2/b^2) b^2 1/EJ dx = [1/3 x^3/b^2]_0^b b^2 1/EJ$$

$$= (1/3 b) b^2 1/EJ = 1/3 b^3/EJ$$

$$L_{BC}^{Xo} = \int_0^b (-7/2 x/b) Fb^2 1/EJ dx = [-7/4 x^2/b]_0^b Fb^2 1/EJ$$

$$= (-7/4 b) Fb^2 1/EJ = -7/4 Fb^3/EJ$$

$$L_{CB}^{Xo} = \int_0^b (-7/2 + 7/2 x/b) Fb^2 1/EJ dx = [-7/2 x + 7/4 x^2/b]_0^b Fb^2 1/EJ$$

$$= (-7/2 b + 7/4 b) Fb^2 1/EJ = -7/4 Fb^3/EJ$$

$$L_{CD}^{Xo} = \int_0^b (-9/2 + 9/2 x/b) Fb^2 1/EJ dx + 1 (-1) 1 Fb^3/EJ$$

$$= [-9/2 x + 9/4 x^2/b]_0^b Fb^2 1/EJ + 1 (-1) 1 Fb^3/EJ$$

$$= (-9/2 b + 9/4 b) Fb^2 1/EJ + 1 (-1) 1 Fb^3/EJ = -13/4 Fb^3/EJ$$

$$L_{DC}^{Xo} = \int_0^b (-9/2 x/b) Fb^2 1/EJ dx + 1 (-1) 1 Fb^3/EJ = [-9/4 x^2/b]_0^b Fb^2 1/EJ + 1 (-1) 1 Fb^3/EJ$$

$$= (-9/4 b) Fb^2 1/EJ + 1 (-1) 1 Fb^3/EJ = -13/4 Fb^3/EJ$$

- $H_{FB} = -F$
- $V_D = -F$
- $W_C = -W = -Fb$
- $W_G = -W = -Fb$
- $W_A = -W = -Fb$
- $p_{FB} = -q = -F/b$
- $q_{CD} = -q = -F/b$
- $\epsilon_{CD} = -\alpha T = -b^2 F/EJ$
- $k_C = 4EJ/b^3$
- $EJ_{AB} = EJ$
- $EJ_{BC} = EJ$
- $EJ_{CD} = EJ$
- $EJ_{DE} = EJ$
- $EJ_{EF} = EJ$
- $EJ_{FG} = EJ$
- $EJ_{GA} = EJ$
- $EJ_{FB} = EJ$
- $EJ_{BE} = EJ$

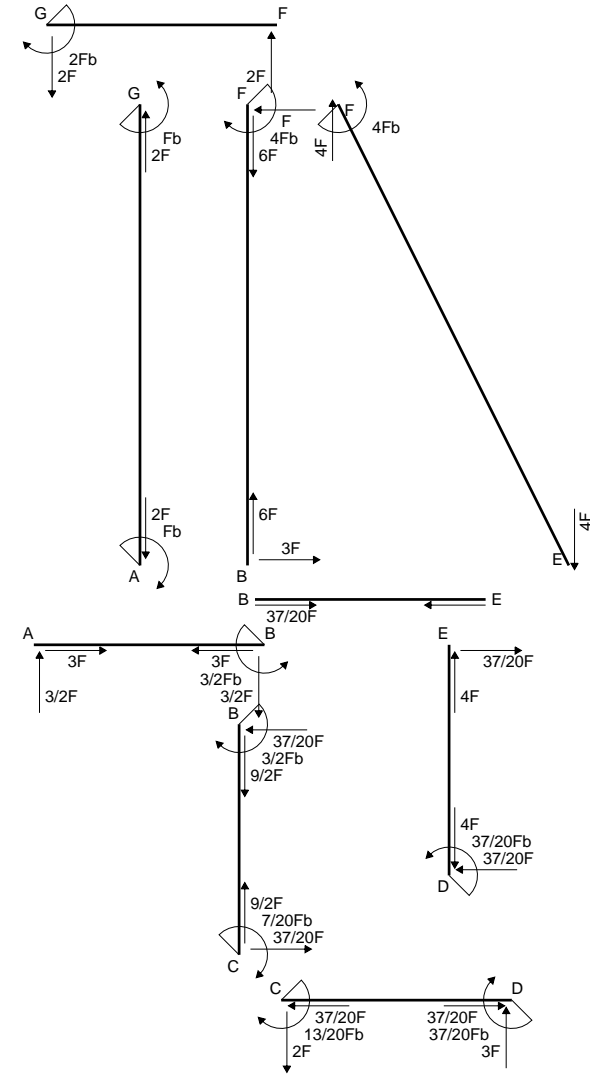
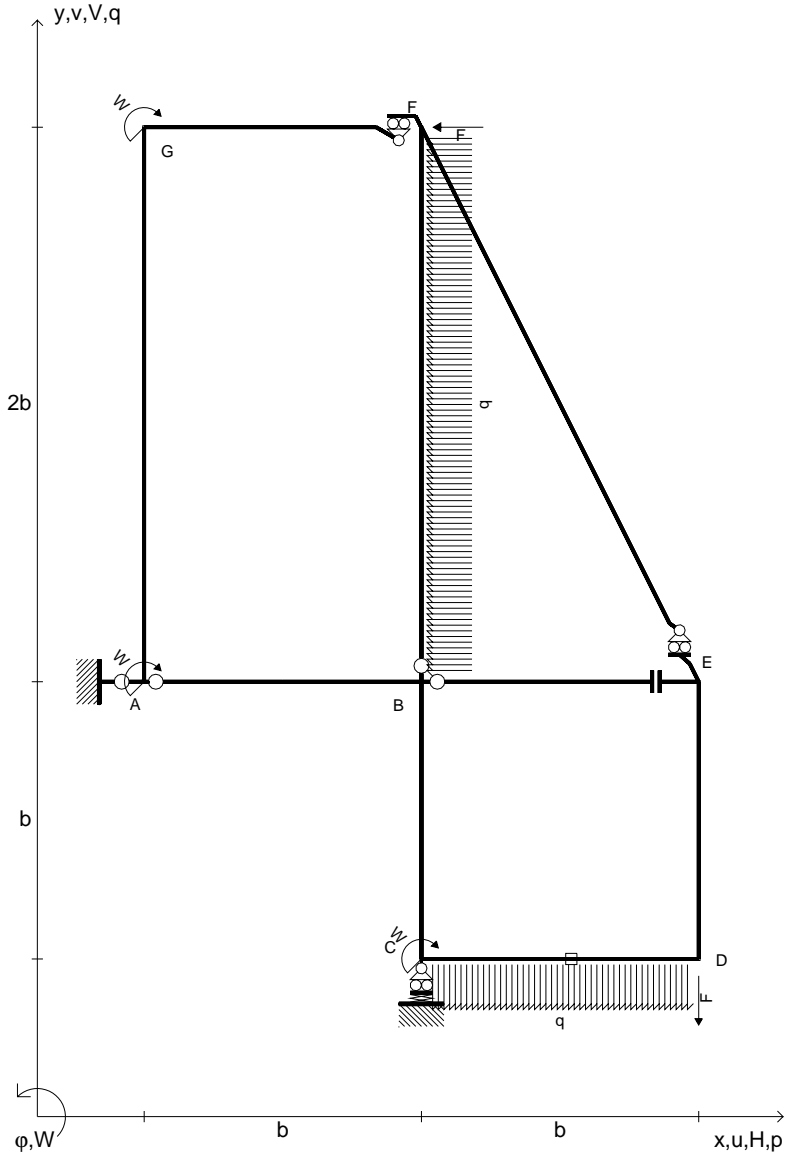

Reazioni iperstatiche in soluzione: $X=W_{DE}$
 Carichi e deformazioni date hanno verso efficace in disegno.
 Calcolare reazioni vincolari della struttura e delle aste.
 Tracciare i diagrammi quotati delle azioni interne nelle aste.
 $J_{YZ} - x_{YZ} - \theta_{YZ}$ riferimento locale asta YZ con origine in Y.
 Elongazione termica specifica ϵ assegnata su asta CD.
 © Adolfo Zavelani Rossi, Politecnico di Milano, vers.27.03.13

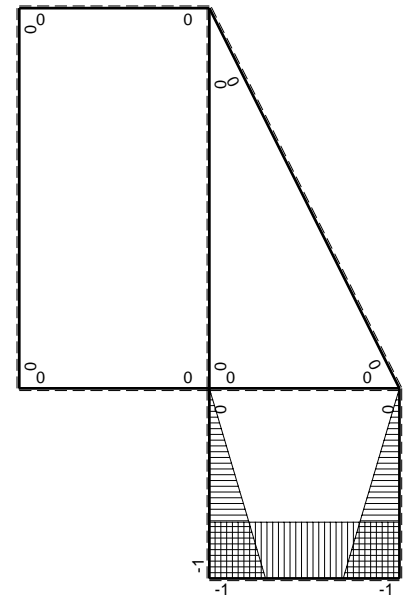
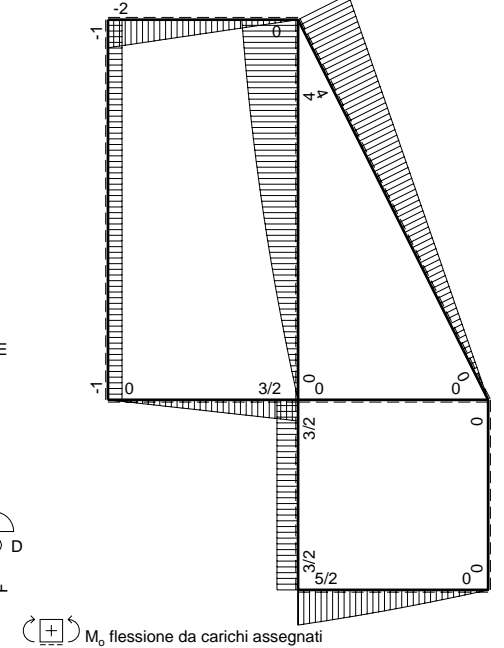
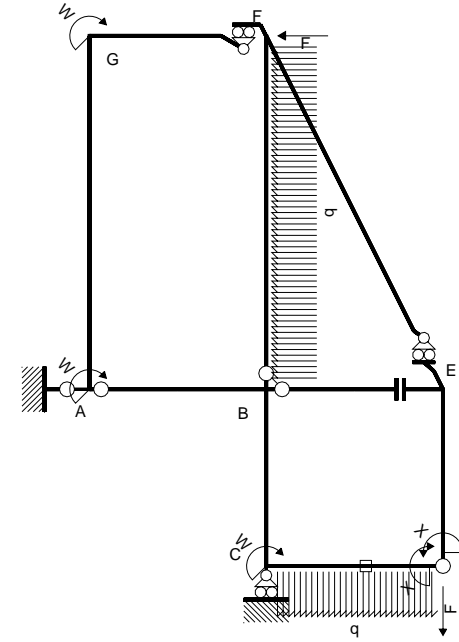
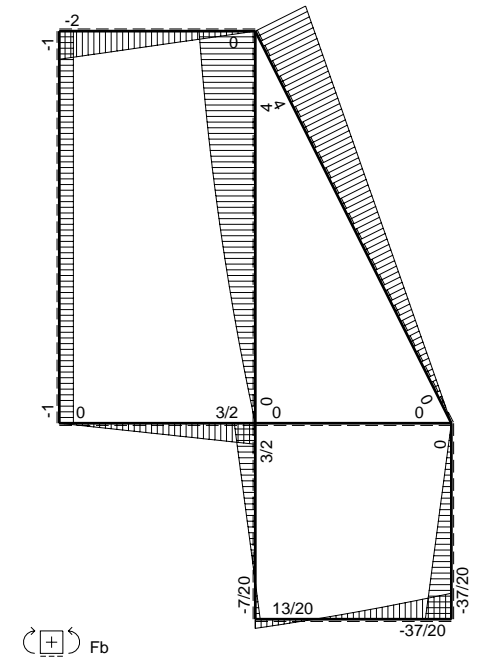
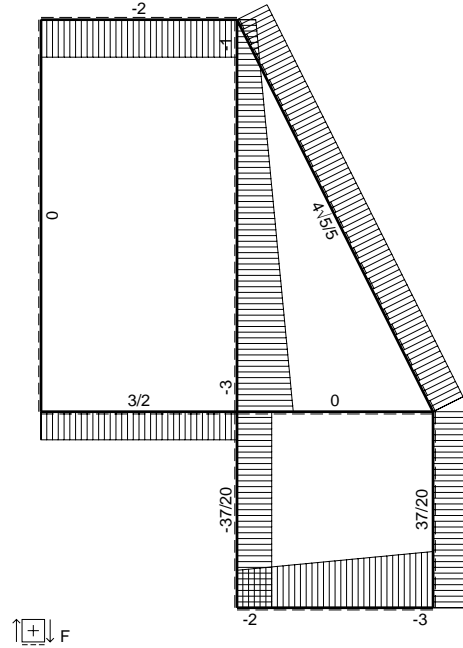
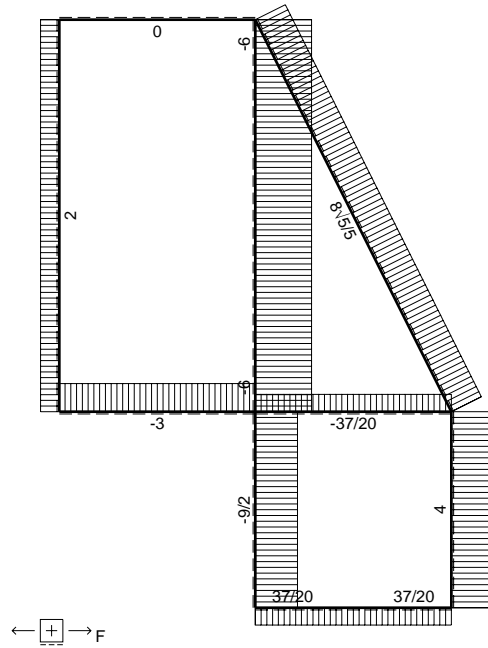

Quadro contributi PLV per iperstatica X=W_{DE}

→	M _x (x)	M _o (x)	M _x M _o	M _x M _x	∫M _x M _o /EJdx	∫XM _x M _x /EJdx
AB b	0	3/2Fx	0	0	0	0
BA b	0	-3/2Fb+3/2Fx	0	0	0	0
BC b	-x/b	3/2Fb	-3/2Fx	x ² /b ²	-3/4Fb ² /EJ	1/3Xb/EJ
CB b	1-x/b	-3/2Fb	-3/2Fb+3/2Fx	1-2x/b+x ² /b ²	-3/4Fb ² /EJ	1/3Xb/EJ
CD b	-1	5/2Fb-2Fx-1/2qx ²	-5/2Fb+2Fx+1/2Fx ² /b	1	-4/3Fb ² /EJ	Xb/EJ
DC b	1	-3Fx+1/2qx ²	-3Fx+1/2Fx ² /b	1	-4/3Fb ² /EJ	Xb/EJ
DE b	-1+x/b	0	0	1-2x/b+x ² /b ²	0	1/3Xb/EJ
ED b	x/b	0	0	x ² /b ²	0	1/3Xb/EJ
EF √5b	0	4√5/5Fx	0	0	0	0
FG b	0	-2Fx	0	0	0	0
GF b	0	2Fb-2Fx	0	0	0	0
GA 2b	0	-Fb	0	0	0	0
AG 2b	0	Fb	0	0	0	0
FB 2b	0	4Fb-Fx-1/2qx ²	0	0	0	0
BF 2b	0	-3Fx+1/2qx ²	0	0	0	0
BE b	0	0	0	0	0	0
EB b	0	0	0	0	0	0
CD	elongazione asta N _{1CD} ε _{CD} L _{CD}				-Fb ² /EJ	
	totali				-37/12Fb ² /EJ	5/3Xb/EJ
	iperstatica X=W _{DE}				37/20Fb	

Sviluppi di calcolo iperstatica

$$L_{BC}^{xx} = \int_0^b (x^2/b^2) 1/EJ dx = [1/3 x^3/b^2]_0^b 1/EJ = (1/3 b) 1/EJ = 1/3 b/EJ$$

$$L_{CB}^{xx} = \int_0^b (1 - 2x/b + x^2/b^2) 1/EJ dx = [x - x^2/b + 1/3 x^3/b^2]_0^b 1/EJ = (b - b + 1/3 b) 1/EJ = 1/3 b/EJ$$

$$L_{CD}^{xx} = \int_0^b (1) 1/EJ dx = [x]_0^b 1/EJ = (b) 1/EJ = b/EJ$$

$$L_{DC}^{xx} = \int_0^b (1) 1/EJ dx = [x]_0^b 1/EJ = (b) 1/EJ = b/EJ$$

$$L_{DE}^{xx} = \int_0^b (1 - 2x/b + x^2/b^2) 1/EJ dx = [x - x^2/b + 1/3 x^3/b^2]_0^b 1/EJ = (b - b + 1/3 b) 1/EJ = 1/3 b/EJ$$

$$L_{ED}^{xx} = \int_0^b (x^2/b^2) 1/EJ dx = [1/3 x^3/b^2]_0^b 1/EJ = (1/3 b) 1/EJ = 1/3 b/EJ$$

$$L_{BC}^{xo} = \int_0^b (-3/2 x/b) Fb 1/EJ dx = [-3/4 x^2/b]_0^b Fb 1/EJ = (-3/4 b) Fb 1/EJ = -3/4 Fb^2/EJ$$

$$L_{CB}^{xo} = \int_0^b (-3/2 + 3/2 x/b) Fb 1/EJ dx = [-3/2 x + 3/4 x^2/b]_0^b Fb 1/EJ = (-3/2 b + 3/4 b) Fb 1/EJ = -3/4 Fb^2/EJ$$

$$L_{CD}^{xo} = \int_0^b (-5/2 + 2x/b + 1/2 x^2/b^2) Fb 1/EJ dx + 1 (-1) 1 Fb^2/EJ = [-5/2 x + x^2/b + 1/6 x^3/b^2]_0^b Fb 1/EJ + 1 (-1) 1 Fb^2/EJ = (-5/2 b + b + 1/6 b) Fb 1/EJ + 1 (-1) 1 Fb^2/EJ = -7/3 Fb^2/EJ$$

$$L_{DC}^{xo} = \int_0^b (-3x/b + 1/2 x^2/b^2) Fb 1/EJ dx + 1 (-1) 1 Fb^2/EJ = [-3/2 x^2/b + 1/6 x^3/b^2]_0^b Fb 1/EJ + 1 (-1) 1 Fb^2/EJ = (-3/2 b + 1/6 b) Fb 1/EJ + 1 (-1) 1 Fb^2/EJ = -7/3 Fb^2/EJ$$

- $H_{FB} = -F$
- $V_D = -F$
- $W_C = -W = -Fb$
- $W_G = -W = -Fb$
- $W_A = -W = -Fb$
- $p_{FB} = -q = -F/b$
- $q_{AB} = -q = -F/b$
- $\epsilon_{BE} = -\alpha T = -b^2 F/EJ$
- $k_C = 4EJ/b^3$
- $EJ_{AB} = EJ$
- $EJ_{BC} = EJ$
- $EJ_{CD} = EJ$
- $EJ_{DE} = EJ$
- $EJ_{EF} = EJ$
- $EJ_{FG} = EJ$
- $EJ_{GA} = EJ$
- $EJ_{FB} = EJ$
- $EJ_{BE} = EJ$

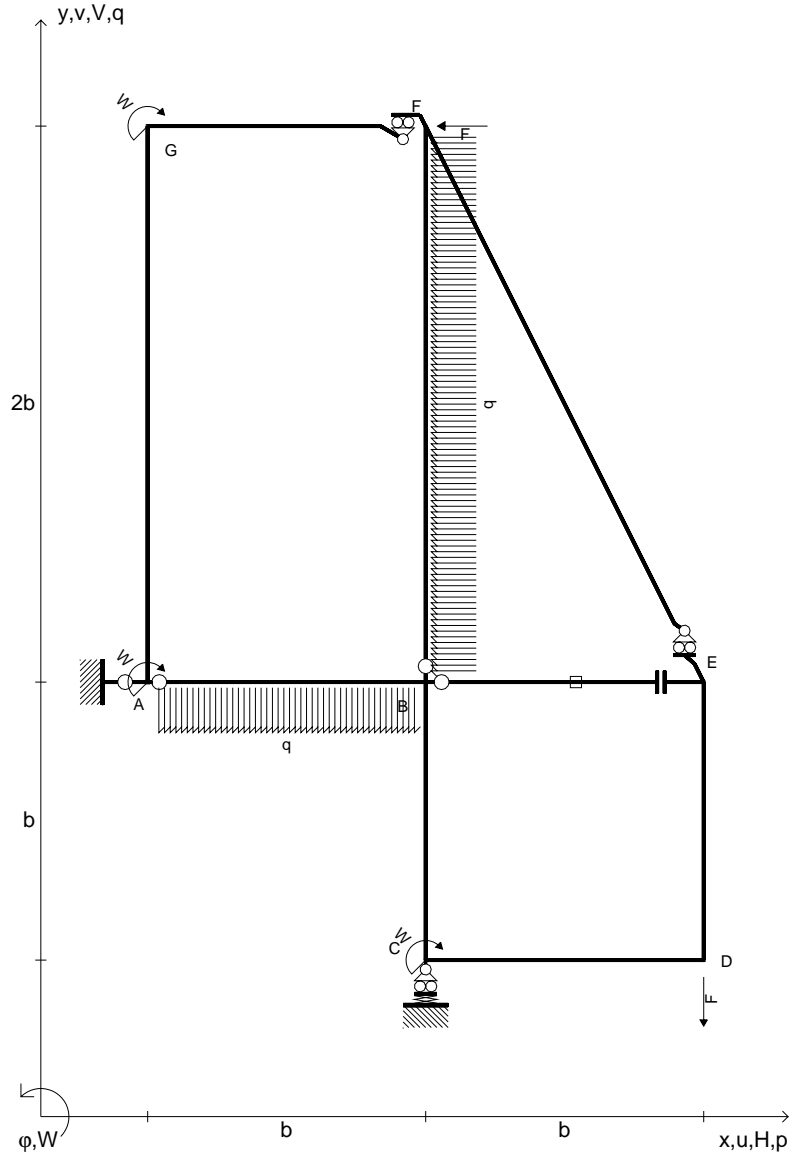

Reazioni iperstatiche in soluzione: $X=W_{DE}$
 Carichi e deformazioni date hanno verso efficace in disegno.
 Calcolare reazioni vincolari della struttura e delle aste.
 Tracciare i diagrammi quotati delle azioni interne nelle aste.
 $J_{YZ} - x_{YZ} - \theta_{YZ}$ riferimento locale asta YZ con origine in Y.
 Elongazione termica specifica ϵ assegnata su asta BE.
 © Adolfo Zavelani Rossi, Politecnico di Milano, vers.27.03.13

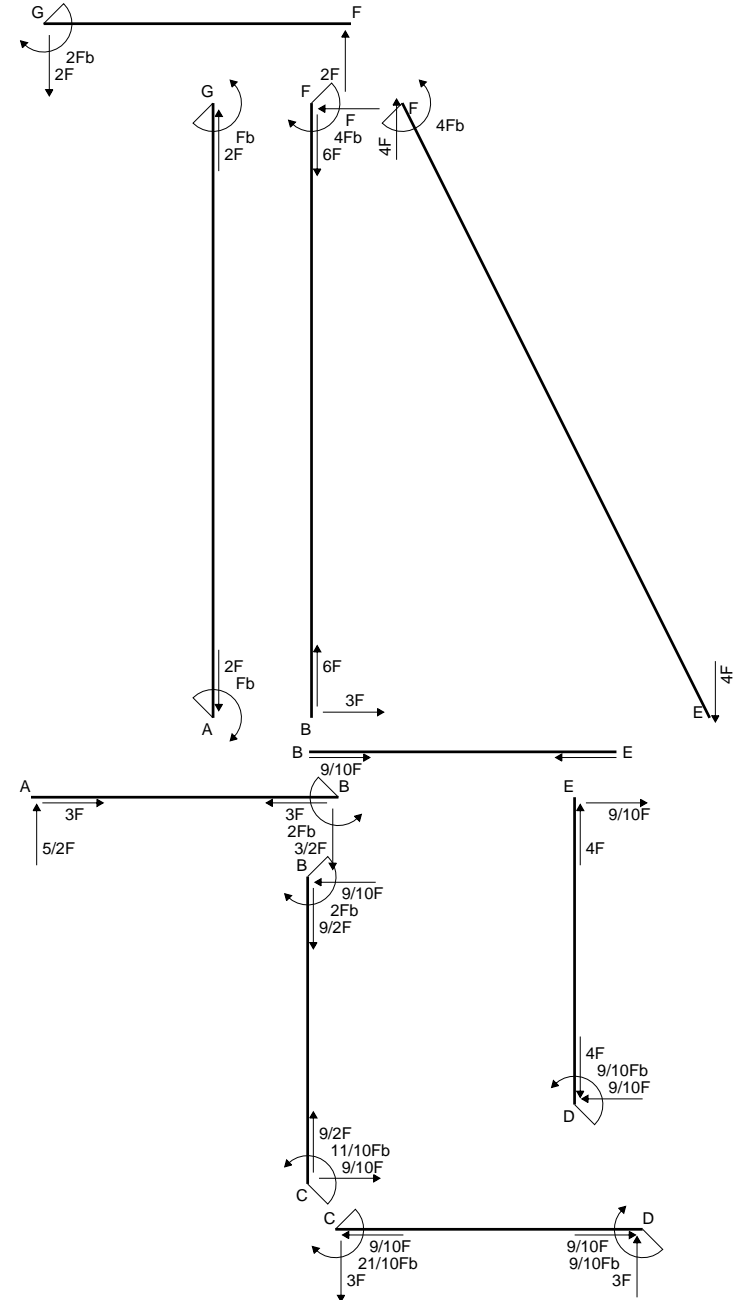

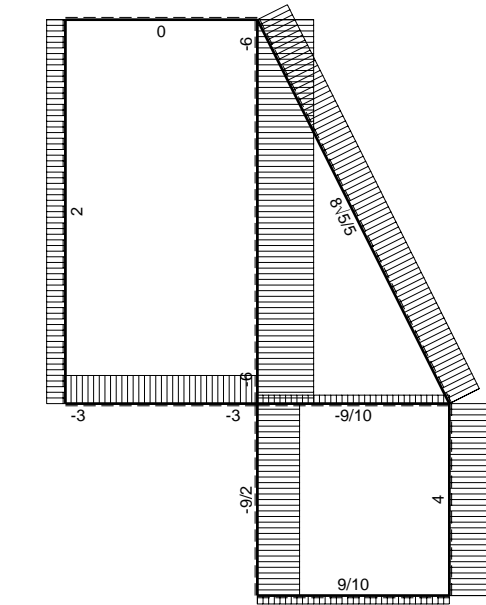

← ⊕ → F

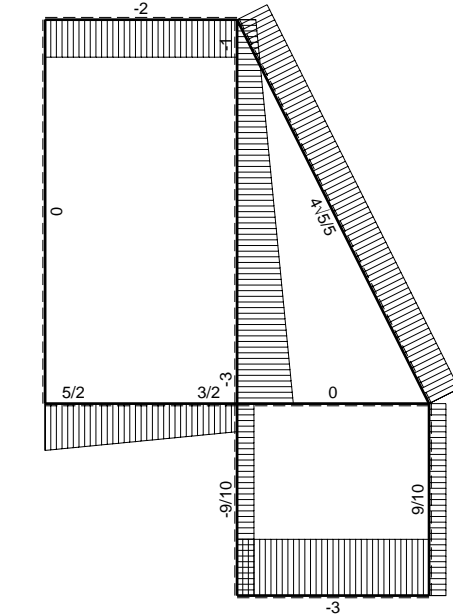

↑ ⊕ ↓ F

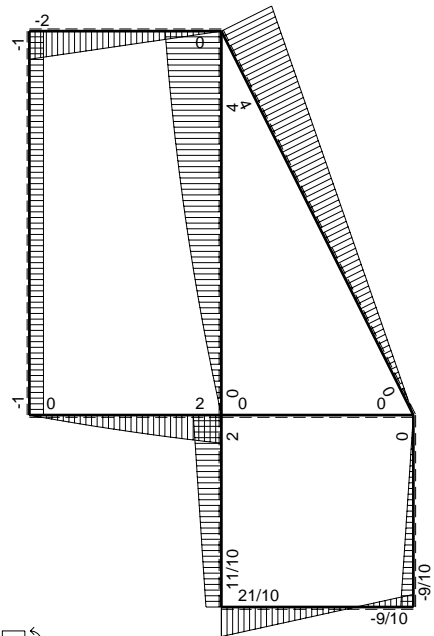

⊕ ⊖ F_b

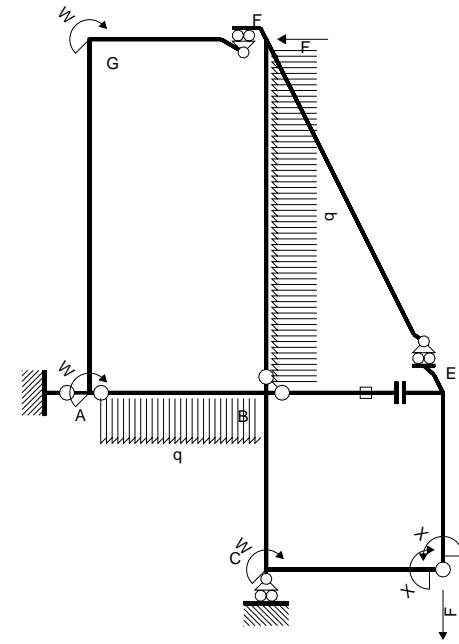

Schema di calcolo iperstatico

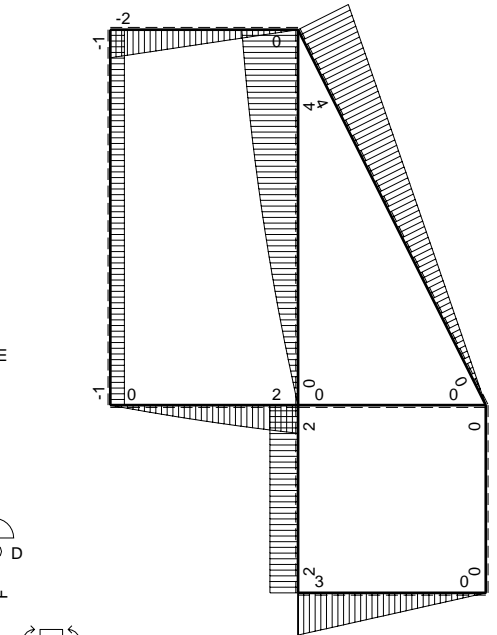

⊕ ⊖ M₀ flessione da carichi assegnati

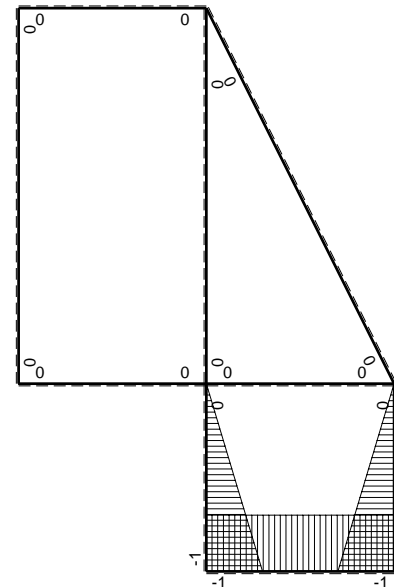

⊕ ⊖ M_x flessione da iperstatica X=1

Quadro contributi PLV per iperstatica $X=W_{DE}$

→	$M_x(x)$	$M_o(x)$	$M_x M_o$	$M_x M_x$	$\int M_x M_o / EJ dx$	$\int X M_x M_x / EJ dx$
AB b	0	$5/2Fx - 1/2qx^2$	0	0	0	0
BA b	0	$-2Fb + 3/2Fx + 1/2qx^2$	0	0	0	0
BC b	-x/b	2Fb	-2Fx	x^2/b^2	$-Fb^2/EJ$	$1/3Xb/EJ$
CB b	1-x/b	-2Fb	$-2Fb + 2Fx$	$1 - 2x/b + x^2/b^2$	$-3/2Fb^2/EJ$	Xb/EJ
CD b	-1	3Fb-3Fx	-3Fb+3Fx	1	$-3/2Fb^2/EJ$	Xb/EJ
DC b	1	-3Fx	-3Fx	1	$-3/2Fb^2/EJ$	Xb/EJ
DE b	-1+x/b	0	0	$1 - 2x/b + x^2/b^2$	0	$1/3Xb/EJ$
ED b	x/b	0	0	x^2/b^2	0	$1/3Xb/EJ$
EF $\sqrt{5}b$	0	$4\sqrt{5}/5Fx$	0	0	0	0
FG b	0	-2Fx	0	0	0	0
GF b	0	2Fb-2Fx	0	0	0	0
GA 2b	0	-Fb	0	0	0	0
AG 2b	0	Fb	0	0	0	0
FB 2b	0	$4Fb - Fx - 1/2qx^2$	0	0	0	0
BF 2b	0	$-3Fx + 1/2qx^2$	0	0	0	0
BE b	0	0	0	0	0	0
EB b	0	0	0	0	0	0
BE	elongazione asta $N_{1BE} \epsilon_{BE} L_{BE}$				Fb^2/EJ	
	totali				$-3/2Fb^2/EJ$	$5/3Xb/EJ$
	iperstatica $X=W_{DE}$				$9/10Fb$	

Sviluppi di calcolo iperstatica

$$L_{BC}^{xx} = \int_0^b (x^2/b^2) 1/EJ dx = [1/3 x^3/b^2]_0^b 1/EJ = (1/3 b) 1/EJ = 1/3 b/EJ$$

$$L_{CB}^{xx} = \int_0^b (1 - 2x/b + x^2/b^2) 1/EJ dx = [x - x^2/b + 1/3 x^3/b^2]_0^b 1/EJ = (b - b + 1/3 b) 1/EJ = 1/3 b/EJ$$

$$L_{CD}^{xx} = \int_0^b (1) 1/EJ dx = [x]_0^b 1/EJ = (b) 1/EJ = b/EJ$$

$$L_{DC}^{xx} = \int_0^b (1) 1/EJ dx = [x]_0^b 1/EJ = (b) 1/EJ = b/EJ$$

$$L_{DE}^{xx} = \int_0^b (1 - 2x/b + x^2/b^2) 1/EJ dx = [x - x^2/b + 1/3 x^3/b^2]_0^b 1/EJ = (b - b + 1/3 b) 1/EJ = 1/3 b/EJ$$

$$L_{ED}^{xx} = \int_0^b (x^2/b^2) 1/EJ dx = [1/3 x^3/b^2]_0^b 1/EJ = (1/3 b) 1/EJ = 1/3 b/EJ$$

$$L_{BC}^{xo} = \int_0^b (-2x/b) Fb 1/EJ dx = [-x^2/b]_0^b Fb 1/EJ = (-b) Fb 1/EJ = -Fb^2/EJ$$

$$L_{CB}^{xo} = \int_0^b (-2 + 2x/b) Fb 1/EJ dx = [-2x + x^2/b]_0^b Fb 1/EJ = (-2b + b) Fb 1/EJ = -Fb^2/EJ$$

$$L_{CD}^{xo} = \int_0^b (-3 + 3x/b) Fb 1/EJ dx = [-3x + 3/2 x^2/b]_0^b Fb 1/EJ = (-3b + 3/2 b) Fb 1/EJ = -3/2 Fb^2/EJ$$

$$L_{DC}^{xo} = \int_0^b (-3x/b) Fb 1/EJ dx = [-3/2 x^2/b]_0^b Fb 1/EJ = (-3/2 b) Fb 1/EJ = -3/2 Fb^2/EJ$$

- $H_{FB} = -F$
- $V_D = -F$
- $W_C = -W = -Fb$
- $W_G = -W = -Fb$
- $W_A = -W = -Fb$
- $q_{FG} = -q = -F/b$
- $p_{GA} = -q = -F/b$
- $\epsilon_{CD} = -\alpha T = -b^2 F/EJ$
- $k_C = 4EJ/b^3$
- $EJ_{AB} = EJ$
- $EJ_{BC} = EJ$
- $EJ_{CD} = EJ$
- $EJ_{DE} = EJ$
- $EJ_{EF} = EJ$
- $EJ_{FG} = EJ$
- $EJ_{GA} = EJ$
- $EJ_{FB} = EJ$
- $EJ_{BE} = EJ$

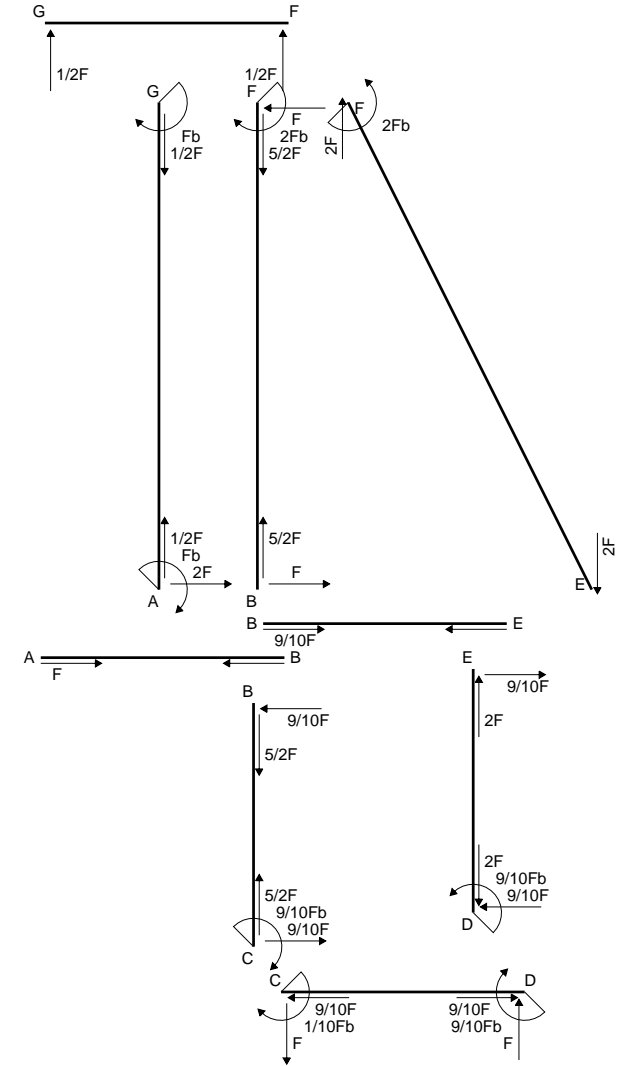
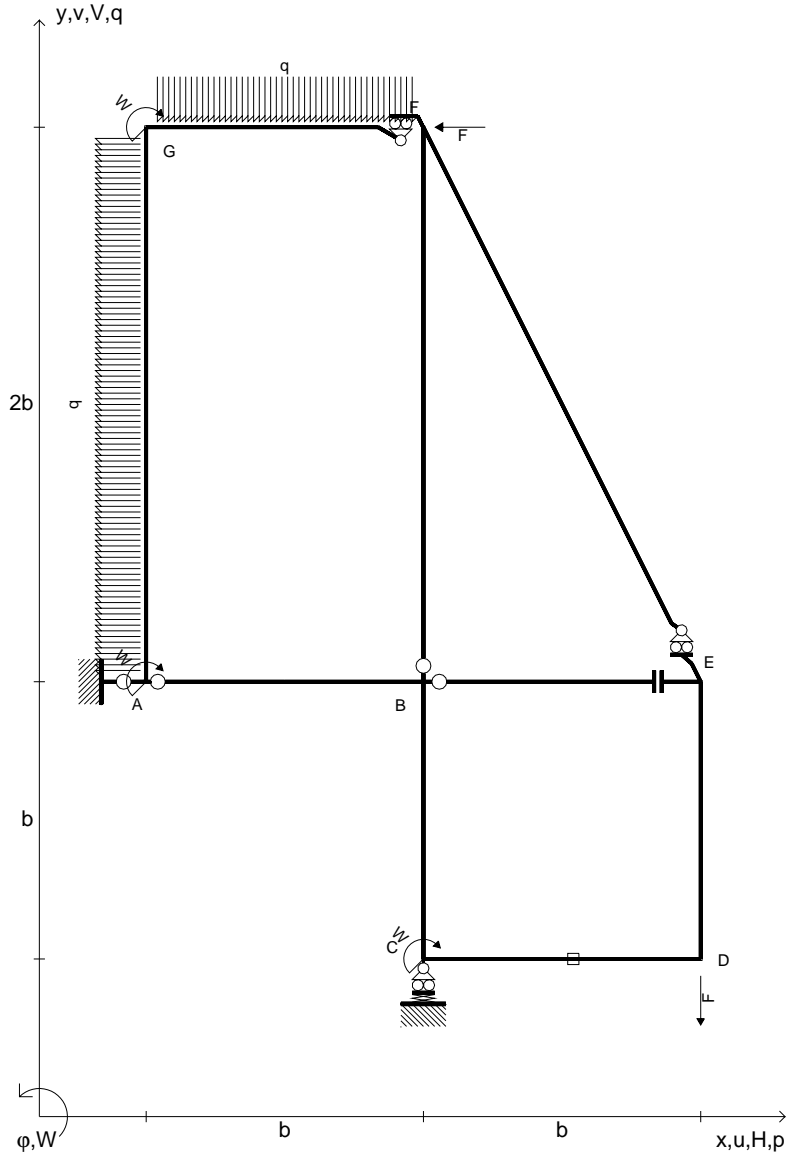

Reazioni iperstatiche in soluzione: $X=W_{CD}$
 Carichi e deformazioni date hanno verso efficace in disegno.
 Calcolare reazioni vincolari della struttura e delle aste.
 Tracciare i diagrammi quotati delle azioni interne nelle aste.
 $J_{YZ} - x_{YZ} - \theta_{YZ}$ riferimento locale asta YZ con origine in Y.
 Elongazione termica specifica ϵ assegnata su asta CD.
 © Adolfo Zavelani Rossi, Politecnico di Milano, vers.27.03.13

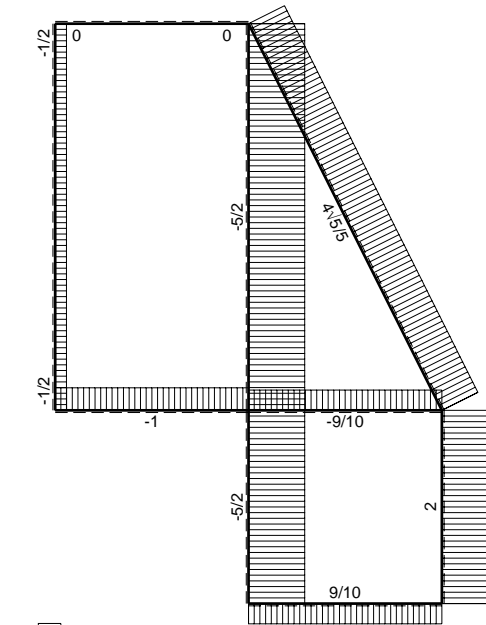

← (+) → F

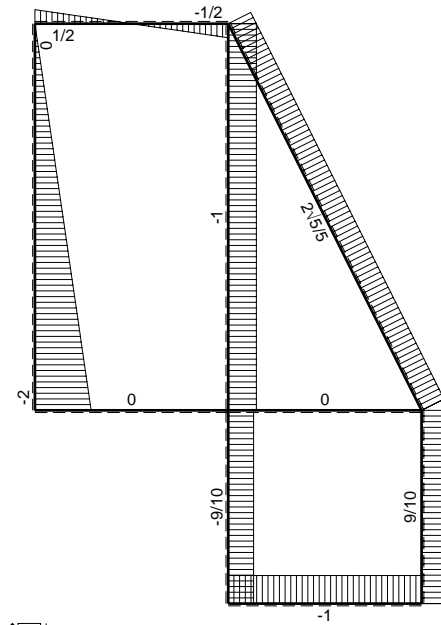

↑ (+) ↓ F

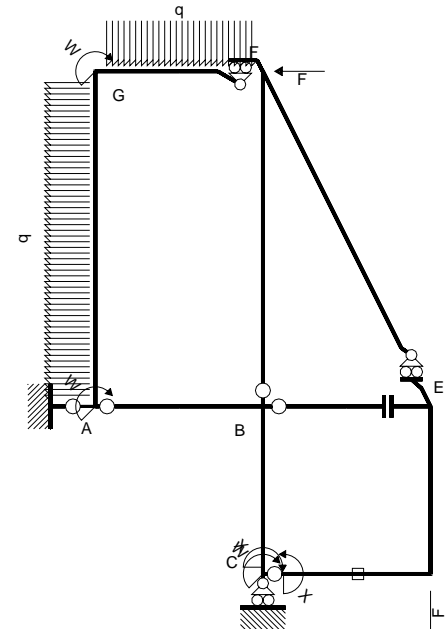

Schema di calcolo iperstatico

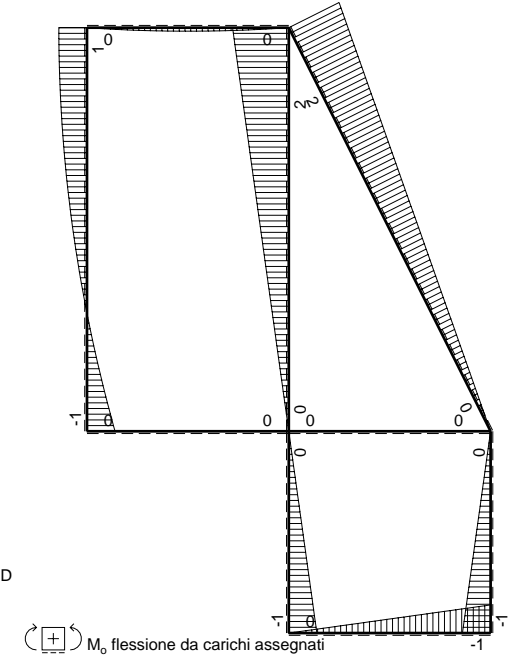

⌚ (+) ↻ M₀ flessione da carichi assegnati

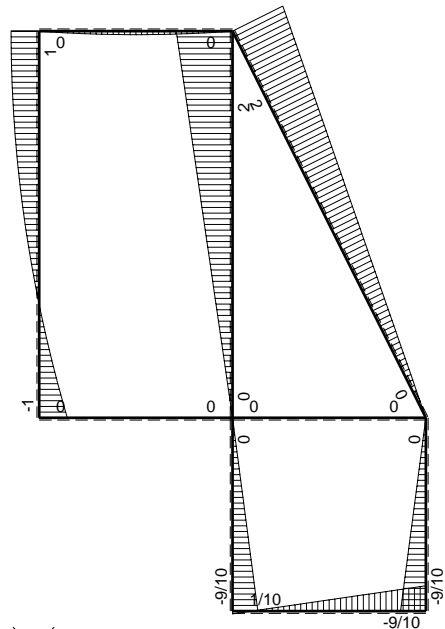

⌚ (+) ↻ F_b

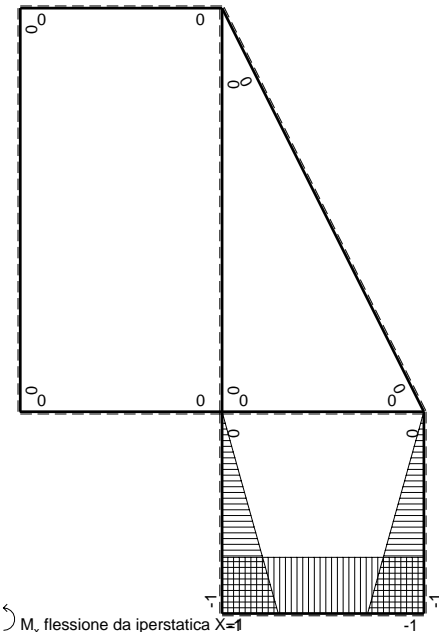

⌚ (+) ↻ M_x flessione da iperstatica X=1

Quadro contributi PLV per iperstatica X=W_{CD}

→	M _x (x)	M ₀ (x)	M _x M ₀	M _x M _x	∫M _x M ₀ /EJdx	∫XM _x M _x /EJdx
AB b	0	0	0	0	0	0
BA b	0	0	0	0		
BC b	-x/b	-Fx	Fx ² /b	x ² /b ²	1/3Fb ² /EJ	1/3Xb/EJ
CB b	1-x/b	Fb-Fx	Fb-2Fx+Fx ² /b	1-2x/b+x ² /b ²		
CD b	-1	-Fx	Fx	1	1/2Fb ² /EJ	Xb/EJ
DC b	1	Fb-Fx	Fb-Fx	1		
DE b	-1+x/b	-Fb+Fx	Fb-2Fx+Fx ² /b	1-2x/b+x ² /b ²	1/3Fb ² /EJ	1/3Xb/EJ
ED b	x/b	Fx	Fx ² /b	x ² /b ²		
EF √5b	0	2√5/5Fx	0	0	0	0
FG b	0	-1/2Fx+1/2qx ²	0	0	0	0
GF b	0	1/2Fx-1/2qx ²	0	0		
GA 2b	0	Fb-1/2qx ²	0	0	0	0
AG 2b	0	Fb-2Fx+1/2qx ²	0	0		
FB 2b	0	2Fb-Fx	0	0	0	0
BF 2b	0	-Fx	0	0		
BE b	0	0	0	0	0	0
EB b	0	0	0	0		
CD	elongazione asta N _{1CD} ε _{CD} L _{CD}				-Fb ² /EJ	
	totali				1/6Fb ² /EJ	5/3Xb/EJ
	iperstatica X=W _{CD}				-1/10Fb	

Sviluppi di calcolo iperstatica

$$L_{BC}^{xx} = \int_0^b (x^2/b^2) 1/EJ dx = [1/3 x^3/b^2]_0^b 1/EJ = (1/3 b) 1/EJ = 1/3 b/EJ$$

$$L_{CB}^{xx} = \int_0^b (1 - 2x/b + x^2/b^2) 1/EJ dx = [x - x^2/b + 1/3 x^3/b^2]_0^b 1/EJ = (b - b + 1/3 b) 1/EJ = 1/3 b/EJ$$

$$L_{CD}^{xx} = \int_0^b (1) 1/EJ dx = [x]_0^b 1/EJ = (b) 1/EJ = b/EJ$$

$$L_{DC}^{xx} = \int_0^b (1) 1/EJ dx = [x]_0^b 1/EJ = (b) 1/EJ = b/EJ$$

$$L_{DE}^{xx} = \int_0^b (1 - 2x/b + x^2/b^2) 1/EJ dx = [x - x^2/b + 1/3 x^3/b^2]_0^b 1/EJ = (b - b + 1/3 b) 1/EJ = 1/3 b/EJ$$

$$L_{ED}^{xx} = \int_0^b (x^2/b^2) 1/EJ dx = [1/3 x^3/b^2]_0^b 1/EJ = (1/3 b) 1/EJ = 1/3 b/EJ$$

$$L_{BC}^{xo} = \int_0^b (x^2/b^2) Fb 1/EJ dx = [1/3 x^3/b^2]_0^b Fb 1/EJ = (1/3 b) Fb 1/EJ = 1/3 Fb^2/EJ$$

$$L_{CB}^{xo} = \int_0^b (1 - 2x/b + x^2/b^2) Fb 1/EJ dx = [x - x^2/b + 1/3 x^3/b^2]_0^b Fb 1/EJ = (b - b + 1/3 b) Fb 1/EJ = 1/3 Fb^2/EJ$$

$$L_{CD}^{xo} = \int_0^b (x/b) Fb 1/EJ dx + 1 (-1) 1 Fb^2/EJ = [1/2 x^2/b]_0^b Fb 1/EJ + 1 (-1) 1 Fb^2/EJ = (1/2 b) Fb 1/EJ + 1 (-1) 1 Fb^2/EJ = -1/2 Fb^2/EJ$$

$$L_{DC}^{xo} = \int_0^b (1 - x/b) Fb 1/EJ dx + 1 (-1) 1 Fb^2/EJ = [x - 1/2 x^2/b]_0^b Fb 1/EJ + 1 (-1) 1 Fb^2/EJ = (b - 1/2 b) Fb 1/EJ + 1 (-1) 1 Fb^2/EJ = -1/2 Fb^2/EJ$$

$$L_{DE}^{xo} = \int_0^b (1 - 2x/b + x^2/b^2) Fb 1/EJ dx = [x - x^2/b + 1/3 x^3/b^2]_0^b Fb 1/EJ = (b - b + 1/3 b) Fb 1/EJ = 1/3 Fb^2/EJ$$

$$L_{ED}^{xo} = \int_0^b (x^2/b^2) Fb 1/EJ dx = [1/3 x^3/b^2]_0^b Fb 1/EJ = (1/3 b) Fb 1/EJ = 1/3 Fb^2/EJ$$

- $H_{FB} = -F$
- $V_D = -F$
- $W_C = -W = -Fb$
- $W_G = -W = -Fb$
- $W_A = -W = -Fb$
- $q_{FG} = -q = -F/b$
- $p_{EF} = -q = -F/b$
- $q_{EF} = -q = -F/b$
- $\epsilon_{CD} = -\alpha T = -b^2 F/EJ$
- $K_C = 4EJ/b^3$
- $EJ_{AB} = EJ$
- $EJ_{BC} = EJ$
- $EJ_{CD} = EJ$
- $EJ_{DE} = EJ$
- $EJ_{EF} = EJ$
- $EJ_{FG} = EJ$
- $EJ_{GA} = EJ$
- $EJ_{FB} = EJ$
- $EJ_{BE} = EJ$

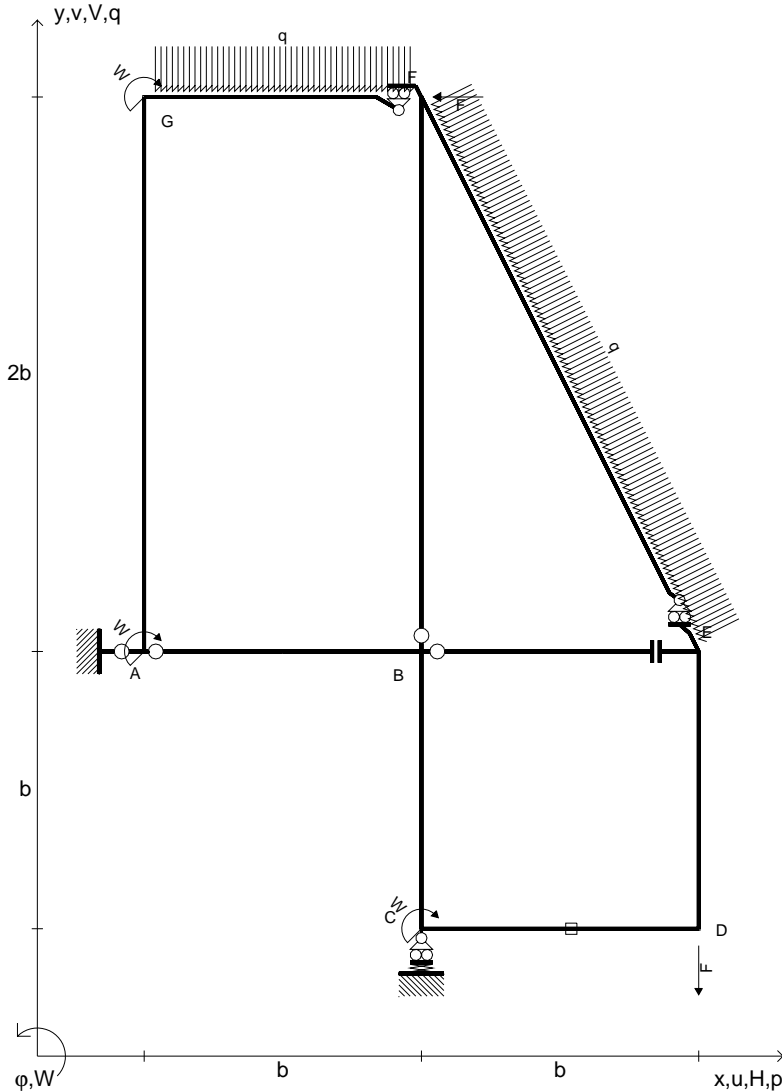

Reazioni iperstatiche in soluzione: $X=W_{DE}$
 Carichi e deformazioni date hanno verso efficace in disegno.
 Calcolare reazioni vincolari della struttura e delle aste.
 Tracciare i diagrammi quotati delle azioni interne nelle aste.
 Diagrammi di carico con valori riferiti ad asse della trave.
 Componenti di carico distribuito riferiti ad assi ortogonali.
 $J_{YZ} - x_{YZ} - \theta_{YZ}$ riferimento locale asta YZ con origine in Y.
 Elongazione termica specifica ϵ assegnata su asta CD.
 © Adolfo Zavelani Rossi, Politecnico di Milano, vers.27.03.13

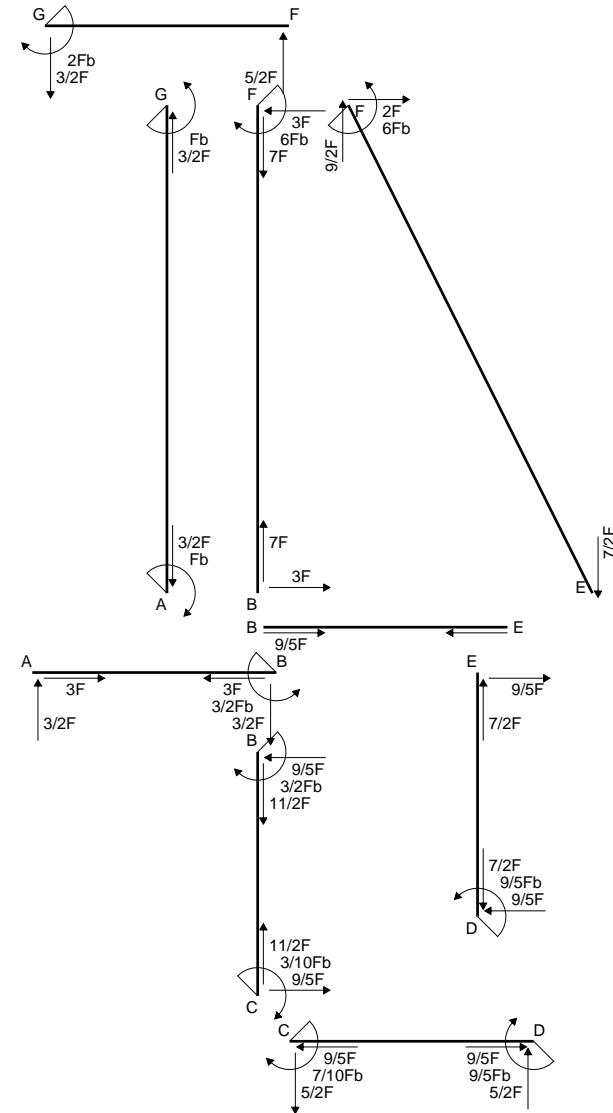

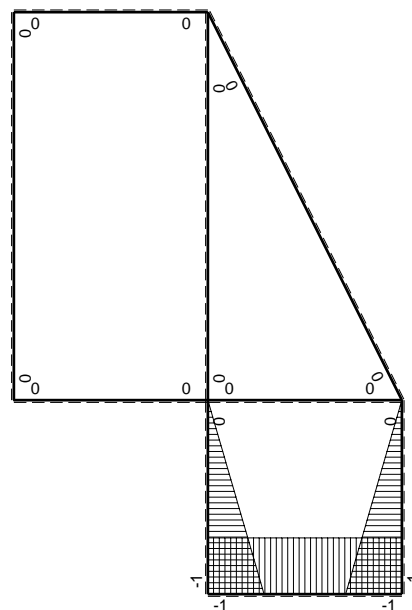
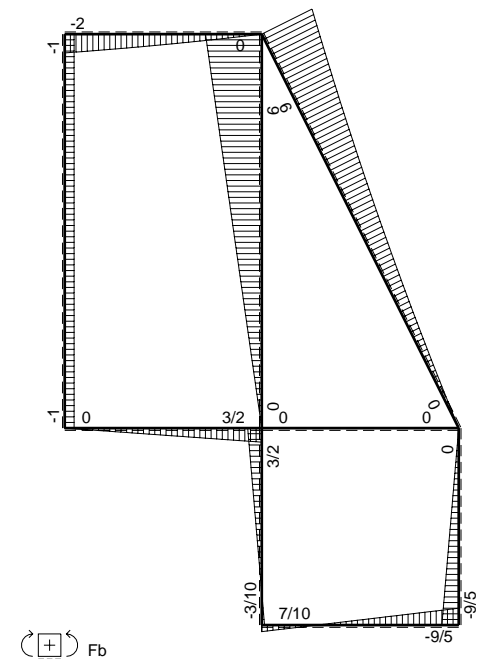
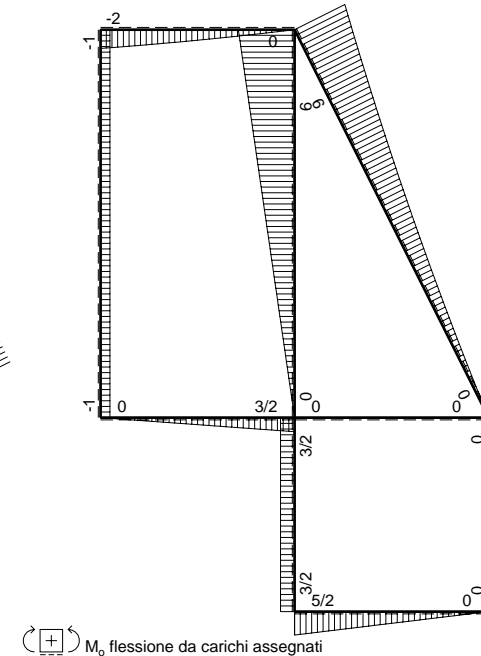
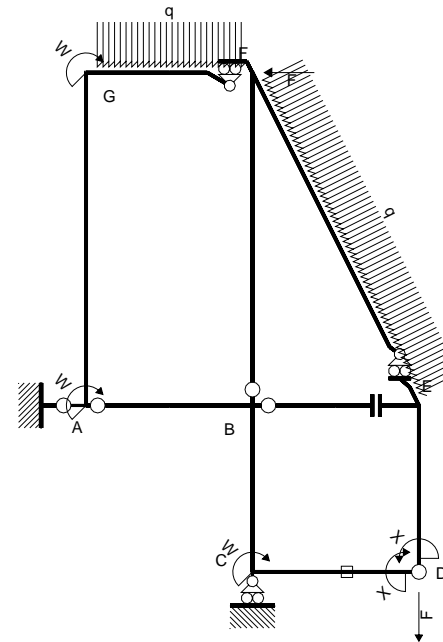
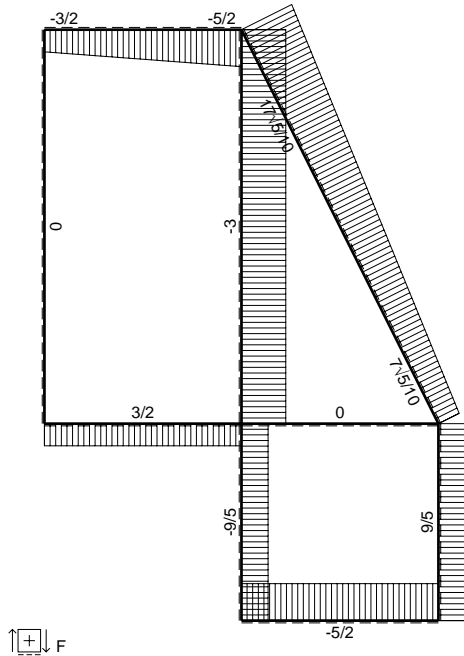
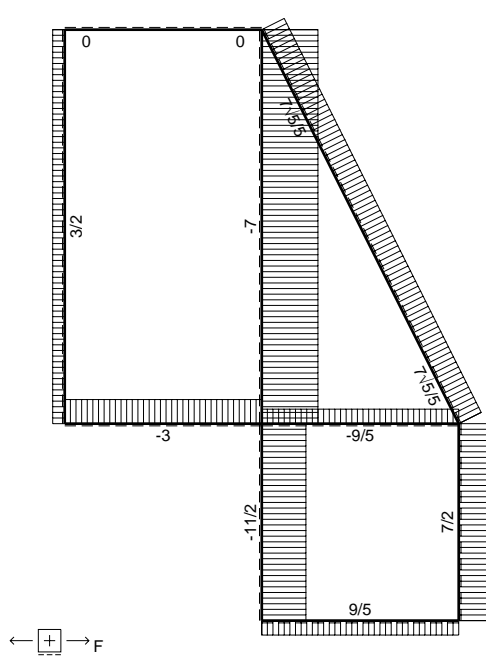

Quadro contributi PLV per iperstatica $X=W_{DE}$

→	$M_x(x)$	$M_o(x)$	$M_x M_o$	$M_x M_x$	$\int M_x M_o / EJ dx$	$\int X M_x M_x / EJ dx$
AB b	0	3/2Fx	0	0	0	0
BA b	0	-3/2Fb+3/2Fx	0	0		
BC b	-x/b	3/2Fb	-3/2Fx	x^2/b^2	-3/4Fb ² /EJ	1/3Xb/EJ
CB b	1-x/b	-3/2Fb	-3/2Fb+3/2Fx	$1-2x/b+x^2/b^2$		
CD b	-1	5/2Fb-5/2Fx	-5/2Fb+5/2Fx	1	-5/4Fb ² /EJ	Xb/EJ
DC b	1	-5/2Fx	-5/2Fx	1		
DE b	-1+x/b	0	0	$1-2x/b+x^2/b^2$	0	1/3Xb/EJ
ED b	x/b	0	0	x^2/b^2		
EF √5b	0	$7\sqrt{5}/10Fx+1/2qx^2$	0	0	0	0
FG b	0	$-5/2Fx+1/2qx^2$	0	0	0	0
GF b	0	$2Fb-3/2Fx-1/2qx^2$	0	0		
GA 2b	0	-Fb	0	0	0	0
AG 2b	0	Fb	0	0		
FB 2b	0	6Fb-3Fx	0	0	0	0
BF 2b	0	-3Fx	0	0		
BE b	0	0	0	0	0	0
EB b	0	0	0	0		
CD	elongazione asta $N_{1CD} \epsilon_{CD} L_{CD}$				-Fb ² /EJ	
	totali				-3Fb ² /EJ	5/3Xb/EJ
	iperstatica $X=W_{DE}$				9/5Fb	

Sviluppi di calcolo iperstatica

$$L_{BC}^{xx} = \int_0^b (x^2/b^2) 1/EJ dx = [1/3 x^3/b^2]_0^b 1/EJ = (1/3 b) 1/EJ = 1/3 b/EJ$$

$$L_{CB}^{xx} = \int_0^b (1 - 2x/b + x^2/b^2) 1/EJ dx = [x - x^2/b + 1/3 x^3/b^2]_0^b 1/EJ = (b - b + 1/3 b) 1/EJ = 1/3 b/EJ$$

$$L_{CD}^{xx} = \int_0^b (1) 1/EJ dx = [x]_0^b 1/EJ = (b) 1/EJ = b/EJ$$

$$L_{DC}^{xx} = \int_0^b (1) 1/EJ dx = [x]_0^b 1/EJ = (b) 1/EJ = b/EJ$$

$$L_{DE}^{xx} = \int_0^b (1 - 2x/b + x^2/b^2) 1/EJ dx = [x - x^2/b + 1/3 x^3/b^2]_0^b 1/EJ = (b - b + 1/3 b) 1/EJ = 1/3 b/EJ$$

$$L_{ED}^{xx} = \int_0^b (x^2/b^2) 1/EJ dx = [1/3 x^3/b^2]_0^b 1/EJ = (1/3 b) 1/EJ = 1/3 b/EJ$$

$$L_{BC}^{xo} = \int_0^b (-3/2 x/b) Fb 1/EJ dx = [-3/4 x^2/b]_0^b Fb 1/EJ = (-3/4 b) Fb 1/EJ = -3/4 Fb^2/EJ$$

$$L_{CB}^{xo} = \int_0^b (-3/2 + 3/2 x/b) Fb 1/EJ dx = [-3/2 x + 3/4 x^2/b]_0^b Fb 1/EJ = (-3/2 b + 3/4 b) Fb 1/EJ = -3/4 Fb^2/EJ$$

$$L_{CD}^{xo} = \int_0^b (-5/2 + 5/2 x/b) Fb 1/EJ dx + 1 (-1) 1 Fb^2/EJ = [-5/2 x + 5/4 x^2/b]_0^b Fb 1/EJ + 1 (-1) 1 Fb^2/EJ = (-5/2 b + 5/4 b) Fb 1/EJ + 1 (-1) 1 Fb^2/EJ = -9/4 Fb^2/EJ$$

$$L_{DC}^{xo} = \int_0^b (-5/2 x/b) Fb 1/EJ dx + 1 (-1) 1 Fb^2/EJ = [-5/4 x^2/b]_0^b Fb 1/EJ + 1 (-1) 1 Fb^2/EJ = (-5/4 b) Fb 1/EJ + 1 (-1) 1 Fb^2/EJ = -9/4 Fb^2/EJ$$

$$L_{DC}^{xo} = \int_0^b (-5/2 x/b) Fb 1/EJ dx + 1 (-1) 1 Fb^2/EJ = [-5/4 x^2/b]_0^b Fb 1/EJ + 1 (-1) 1 Fb^2/EJ = (-5/4 b) Fb 1/EJ + 1 (-1) 1 Fb^2/EJ = -9/4 Fb^2/EJ$$

- $H_{FB} = -F$
- $V_D = -F$
- $W_C = -W = -Fb$
- $W_G = -W = -Fb$
- $W_A = -W = -Fb$
- $q_{FG} = -q = -F/b$
- $q_{CD} = -q = -F/b$
- $\epsilon_{BE} = -\alpha T = -b^2 F/EJ$
- $k_C = 4EJ/b^3$
- $EJ_{AB} = EJ$
- $EJ_{BC} = EJ$
- $EJ_{CD} = EJ$
- $EJ_{DE} = EJ$
- $EJ_{EF} = EJ$
- $EJ_{FG} = EJ$
- $EJ_{GA} = EJ$
- $EJ_{FB} = EJ$
- $EJ_{BE} = EJ$

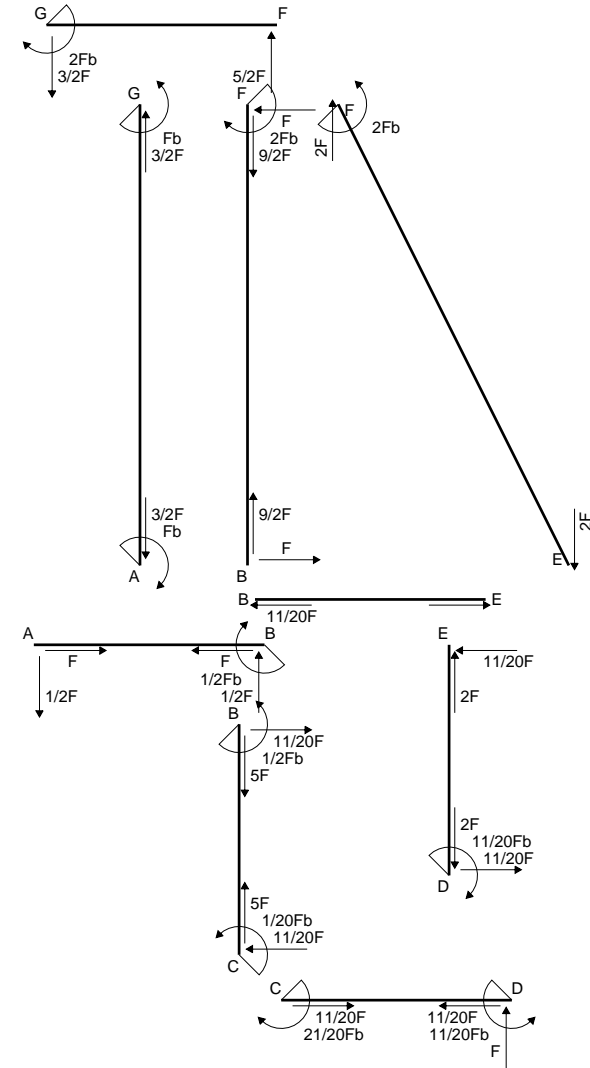
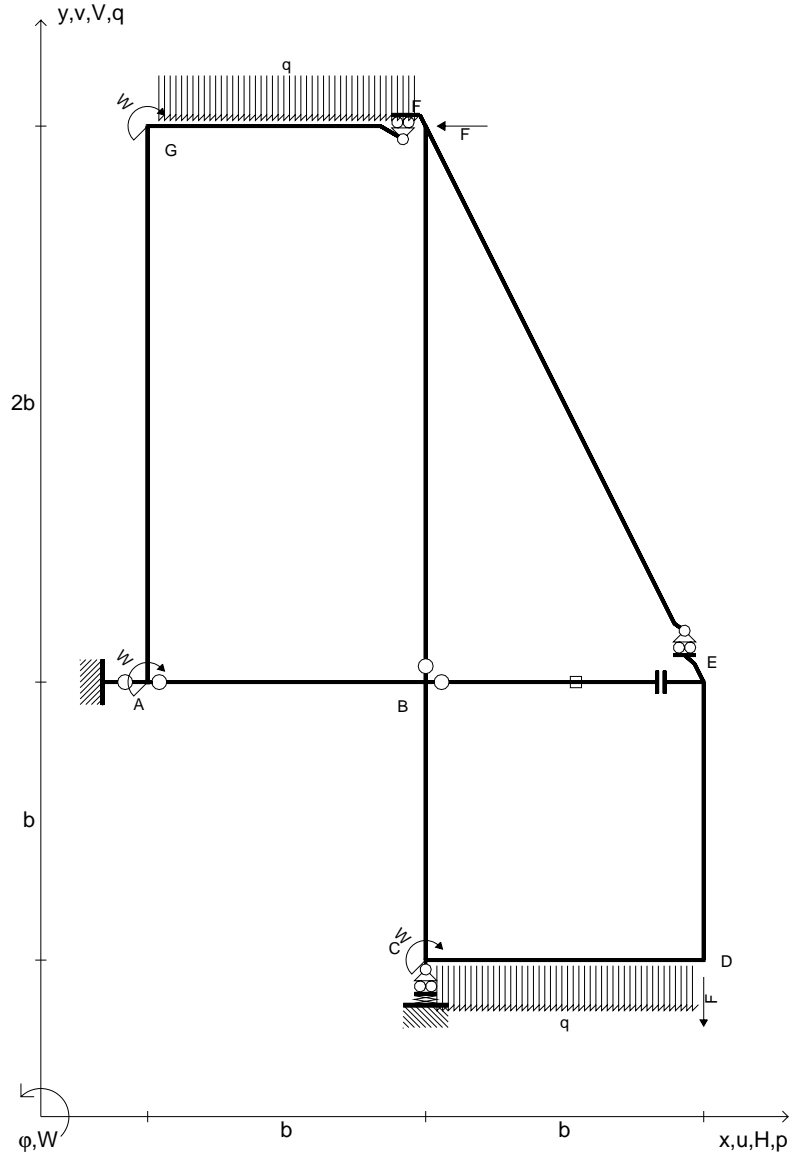

Reazioni iperstatiche in soluzione: $X=W_{DE}$
 Carichi e deformazioni date hanno verso efficace in disegno.
 Calcolare reazioni vincolari della struttura e delle aste.
 Tracciare i diagrammi quotati delle azioni interne nelle aste.
 $J_{YZ} - x_{YZ} - \theta_{YZ}$ riferimento locale asta YZ con origine in Y.
 Elongazione termica specifica ϵ assegnata su asta BE.
 © Adolfo Zavelani Rossi, Politecnico di Milano, vers.27.03.13

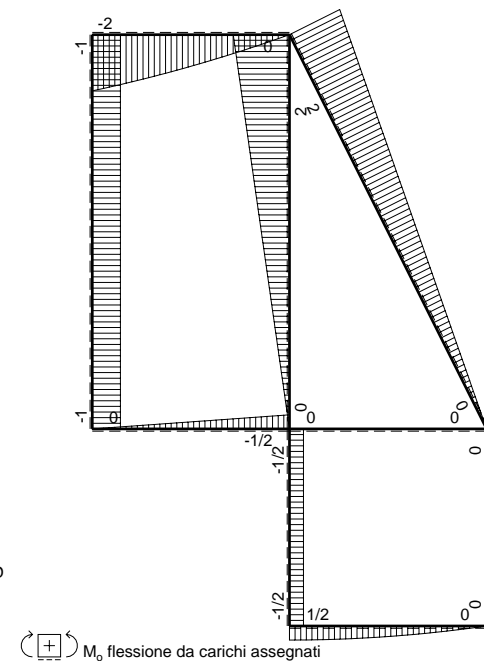
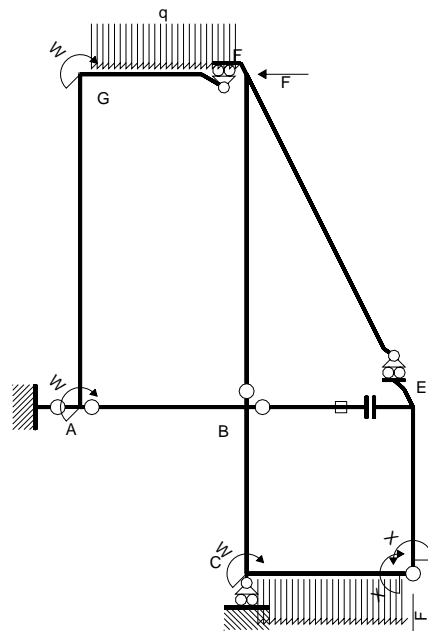
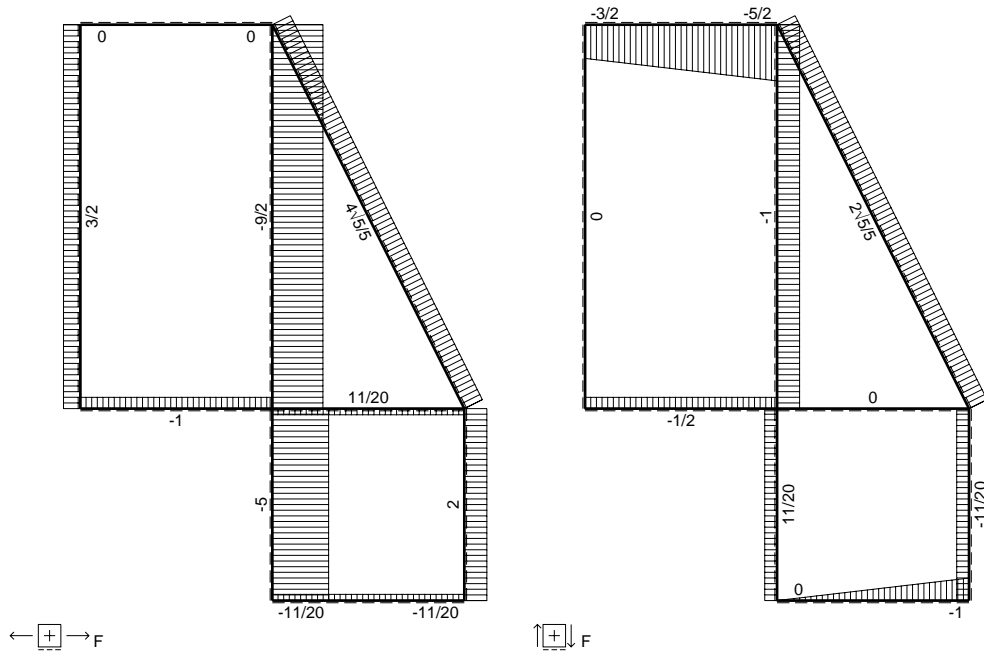

Schema di calcolo iperstatico

M_o flessione da carichi assegnati

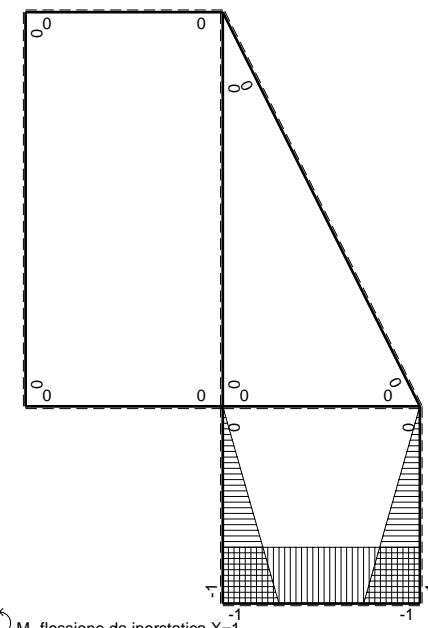
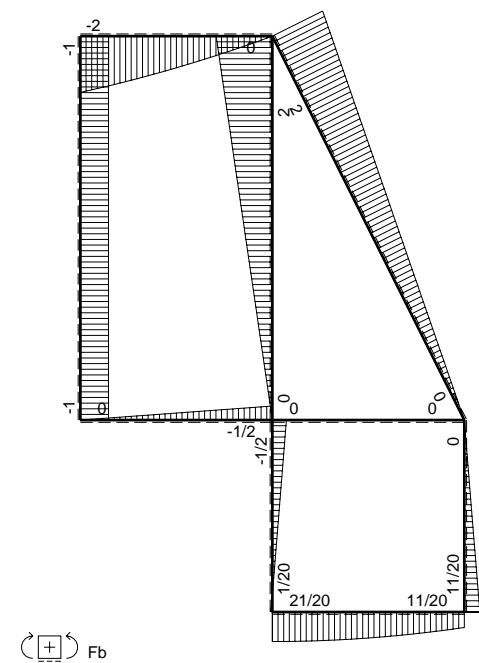

M_x flessione da iperstatica $X=1$

Quadro contributi PLV per iperstatica X=W_{DE}

→	M _x (x)	M _o (x)	M _x M _o	M _x M _x	$\int M_x M_o / EJ dx$	$\int X M_x M_x / EJ dx$
AB b	0	-1/2Fx	0	0	0	0
BA b	0	1/2Fb-1/2Fx	0	0		
BC b	-x/b	-1/2Fb	1/2Fx	x ² /b ²	1/4Fb ² /EJ	1/3Xb/EJ
CB b	1-x/b	1/2Fb	1/2Fb-1/2Fx	1-2x/b+x ² /b ²		
CD b	-1	1/2Fb-1/2qx ²	-1/2Fb+1/2Fx ² /b	1	-1/3Fb ² /EJ	Xb/EJ
DC b	1	-Fx+1/2qx ²	-Fx+1/2Fx ² /b	1		
DE b	-1+x/b	0	0	1-2x/b+x ² /b ²	0	1/3Xb/EJ
ED b	x/b	0	0	x ² /b ²		
EF √5b	0	2√5/5Fx	0	0	0	0
FG b	0	-5/2Fx+1/2qx ²	0	0	0	0
GF b	0	2Fb-3/2Fx-1/2qx ²	0	0		
GA 2b	0	-Fb	0	0	0	0
AG 2b	0	Fb	0	0		
FB 2b	0	2Fb-Fx	0	0	0	0
BF 2b	0	-Fx	0	0		
BE b	0	0	0	0	0	0
EB b	0	0	0	0	0	0
BE	elongazione asta N _{1BE} ε _{BE} L _{BE}				Fb ² /EJ	
	totali				11/12Fb ² /EJ	5/3Xb/EJ
	iperstatica X=W _{DE}				-11/20Fb	

Sviluppi di calcolo iperstatica

$$L_{BC}^{xx} = \int_0^b (x^2/b^2) 1/EJ dx = [1/3 x^3/b^2]_0^b 1/EJ = (1/3 b) 1/EJ = 1/3 b/EJ$$

$$L_{CB}^{xx} = \int_0^b (1 - 2x/b + x^2/b^2) 1/EJ dx = [x - x^2/b + 1/3 x^3/b^2]_0^b 1/EJ = (b - b + 1/3 b) 1/EJ = 1/3 b/EJ$$

$$L_{CD}^{xx} = \int_0^b (1) 1/EJ dx = [x]_0^b 1/EJ = (b) 1/EJ = b/EJ$$

$$L_{DC}^{xx} = \int_0^b (1) 1/EJ dx = [x]_0^b 1/EJ = (b) 1/EJ = b/EJ$$

$$L_{DE}^{xx} = \int_0^b (1 - 2x/b + x^2/b^2) 1/EJ dx = [x - x^2/b + 1/3 x^3/b^2]_0^b 1/EJ = (b - b + 1/3 b) 1/EJ = 1/3 b/EJ$$

$$L_{ED}^{xx} = \int_0^b (x^2/b^2) 1/EJ dx = [1/3 x^3/b^2]_0^b 1/EJ = (1/3 b) 1/EJ = 1/3 b/EJ$$

$$L_{BC}^{xo} = \int_0^b (1/2 x/b) Fb 1/EJ dx = [1/4 x^2/b]_0^b Fb 1/EJ = (1/4 b) Fb 1/EJ = 1/4 Fb^2/EJ$$

$$L_{CB}^{xo} = \int_0^b (1/2 - 1/2 x/b) Fb 1/EJ dx = [1/2 x - 1/4 x^2/b]_0^b Fb 1/EJ = (1/2 b - 1/4 b) Fb 1/EJ = 1/4 Fb^2/EJ$$

$$L_{CD}^{xo} = \int_0^b (-1/2 + 1/2 x^2/b^2) Fb 1/EJ dx = [-1/2 x + 1/6 x^3/b^2]_0^b Fb 1/EJ = (-1/2 b + 1/6 b) Fb 1/EJ = -1/3 Fb^2/EJ$$

$$L_{DC}^{xo} = \int_0^b (-x/b + 1/2 x^2/b^2) Fb 1/EJ dx = [-1/2 x^2/b + 1/6 x^3/b^2]_0^b Fb 1/EJ = (-1/2 b + 1/6 b) Fb 1/EJ = -1/3 Fb^2/EJ$$

