

Schema di calcolo iperstatico

M_0 flessione da carichi assegnati



M_x flessione da iperstatica $X=1$

Quadro contributi PLV per iperstatica $X=H_A$

→	$M_x(x)$	$M_o(x)$	θ	$M_x M_o$	$M_x \theta$	$M_x M_x$	$\int M_x(M_o/EJ+\theta)dx$	$\int X M_x M_x/EJ dx$
AB b	-x	$1/2qx^2$	0	$-1/2qx^3$	0	x^2	$(-1/8+0)Fb^3/EJ$	$1/3Xb^3/EJ$
BA b	b-x	$-1/2Fb+Fx-1/2qx^2$	0	$-1/2Fb^2+3/2Fbx-3/2Fx^2+1/2qx^3$	0	$b^2-2bx+x^2$		
BC b	-b+1/2x	$1/2Fb-Fx$	0	$-1/2Fb^2+5/4Fbx-1/2Fx^2$	0	$b^2-bx+1/4x^2$	$(-1/24+0)Fb^3/EJ$	$7/12Xb^3/EJ$
CB b	$1/2b+1/2x$	$1/2Fb-Fx$	0	$1/4Fb^2-1/4Fbx-1/2Fx^2$	0	$1/4b^2+1/2bx+1/4x^2$		
CD b	$-1/2b+1/2x$	$-1/2Fb+1/2Fx$	$-Fb/EJ$	$1/4Fb^2-1/2Fbx+1/4Fx^2$	$1/2Fb^2/EJ-1/2Fxb/EJ$	$1/4b^2-1/2bx+1/4x^2$	$(1/12+1/4)Fb^3/EJ$	$1/12Xb^3/EJ$
DC b	$1/2x$	$1/2Fx$	Fb/EJ	$1/4Fx^2$	$1/2Fxb/EJ$	$1/4x^2$		
DE b	0	0	0	0	0	0	0+0	0
ED b	0	0	0	0	0	0		
EF b	0	$5/2Fb-3Fx+1/2qx^2$	0	0	0	0	0+0	0
FE b	0	$-2Fx-1/2qx^2$	0	0	0	0		
FC b	0	0	0	0	0	0	0+0	0
CF b	0	0	0	0	0	0		
CG b	0	0	0	0	0	0	0+0	0
GC b	0	0	0	0	0	0		
GH 2b	0	$Fb-1/2Fx$	0	0	0	0	0+0	0
HG 2b	0	$-1/2Fx$	0	0	0	0		
HI 2b	0	0	0	0	0	0	0+0	0
IH 2b	0	0	0	0	0	0		
IE b	0	$Fb+3/2Fx$	0	0	0	0	0+0	0
EI b	0	$-5/2Fb+3/2Fx$	0	0	0	0		
A	cedimento nodo $-H_{1A}u_A$						Fb^3/EJ	
	totali						$7/6Fb^3/EJ$	Xb^3/EJ
	iperstatica $X=H_A$						$-7/6F$	

Sviluppi di calcolo iperstatica

$$L_{AB}^{xx} = \int_0^b \left(\frac{x^2}{b^2} \right) b^2 \frac{1}{EJ} dx = \left[\frac{1}{3} \frac{x^3}{b^2} \right]_0^b b^2 \frac{1}{EJ}$$

$$= \left(\frac{1}{3} b \right) b^2 \frac{1}{EJ} = \frac{1}{3} b^3/EJ$$

$$L_{BA}^{xx} = \int_0^b \left(1 - 2x/b + \frac{x^2}{b^2} \right) b^2 \frac{1}{EJ} dx = \left[x - \frac{x^2}{b} + \frac{1}{3} \frac{x^3}{b^2} \right]_0^b b^2 \frac{1}{EJ}$$

$$= \left(b - b + \frac{1}{3} b \right) b^2 \frac{1}{EJ} = \frac{1}{3} b^3/EJ$$

$$L_{BC}^{xx} = \int_0^b \left(1 - x/b + \frac{1}{4} \frac{x^2}{b^2} \right) b^2 \frac{1}{EJ} dx = \left[x - \frac{1}{2} \frac{x^2}{b} + \frac{1}{12} \frac{x^3}{b^2} \right]_0^b b^2 \frac{1}{EJ}$$

$$= \left(b - \frac{1}{2} b + \frac{1}{12} b \right) b^2 \frac{1}{EJ} = \frac{7}{12} b^3/EJ$$

$$L_{CB}^{xx} = \int_0^b \left(\frac{1}{4} + \frac{1}{2} \frac{x}{b} + \frac{1}{4} \frac{x^2}{b^2} \right) b^2 \frac{1}{EJ} dx = \left[\frac{1}{4} x + \frac{1}{4} \frac{x^2}{b} + \frac{1}{12} \frac{x^3}{b^2} \right]_0^b b^2 \frac{1}{EJ}$$

$$= \left(\frac{1}{4} b + \frac{1}{4} b + \frac{1}{12} b \right) b^2 \frac{1}{EJ} = \frac{7}{12} b^3/EJ$$

$$L_{CD}^{xx} = \int_0^b \left(\frac{1}{4} - \frac{1}{2} \frac{x}{b} + \frac{1}{4} \frac{x^2}{b^2} \right) b^2 \frac{1}{EJ} dx = \left[\frac{1}{4} x - \frac{1}{4} \frac{x^2}{b} + \frac{1}{12} \frac{x^3}{b^2} \right]_0^b b^2 \frac{1}{EJ}$$

$$= \left(\frac{1}{4} b - \frac{1}{4} b + \frac{1}{12} b \right) b^2 \frac{1}{EJ} = \frac{1}{12} b^3/EJ$$

$$L_{DC}^{xx} = \int_0^b \left(\frac{1}{4} \frac{x^2}{b^2} \right) b^2 \frac{1}{EJ} dx = \left[\frac{1}{12} \frac{x^3}{b^2} \right]_0^b b^2 \frac{1}{EJ}$$

$$= \left(\frac{1}{12} b \right) b^2 \frac{1}{EJ} = \frac{1}{12} b^3/EJ$$

$$L_{AB}^{xo} = \int_0^b \left(-\frac{1}{2} \frac{x^3}{b^3} \right) Fb^2 \frac{1}{EJ} dx = \left[-\frac{1}{8} \frac{x^4}{b^3} \right]_0^b Fb^2 \frac{1}{EJ}$$

$$= \left(-\frac{1}{8} b \right) Fb^2 \frac{1}{EJ} = -\frac{1}{8} Fb^3/EJ$$

$$L_{BA}^{xo} = \int_0^b \left(-\frac{1}{2} + \frac{3}{2} \frac{x}{b} - \frac{3}{2} \frac{x^2}{b^2} + \frac{1}{2} \frac{x^3}{b^3} \right) Fb^2 \frac{1}{EJ} dx$$

$$= \left[-\frac{1}{2} x + \frac{3}{4} \frac{x^2}{b} - \frac{1}{2} \frac{x^3}{b^2} + \frac{1}{8} \frac{x^4}{b^3} \right]_0^b Fb^2 \frac{1}{EJ}$$

$$= \left(-\frac{1}{2} b + \frac{3}{4} b - \frac{1}{2} b + \frac{1}{8} b \right) Fb^2 \frac{1}{EJ} = -\frac{1}{8} Fb^3/EJ$$

$$L_{BC}^{xo} = \int_0^b \left(-\frac{1}{2} + \frac{5}{4} \frac{x}{b} - \frac{1}{2} \frac{x^2}{b^2} \right) Fb^2 \frac{1}{EJ} dx = \left[-\frac{1}{2} x + \frac{5}{8} \frac{x^2}{b} - \frac{1}{6} \frac{x^3}{b^2} \right]_0^b Fb^2 \frac{1}{EJ}$$

$$= \left(-\frac{1}{2} b + \frac{5}{8} b - \frac{1}{6} b \right) Fb^2 \frac{1}{EJ} = -\frac{1}{24} Fb^3/EJ$$

$$L_{CB}^{xo} = \int_0^b \left(\frac{1}{4} - \frac{1}{4} \frac{x}{b} - \frac{1}{2} \frac{x^2}{b^2} \right) Fb^2 \frac{1}{EJ} dx = \left[\frac{1}{4} x - \frac{1}{8} \frac{x^2}{b} - \frac{1}{6} \frac{x^3}{b^2} \right]_0^b Fb^2 \frac{1}{EJ}$$

$$= \left(\frac{1}{4} b - \frac{1}{8} b - \frac{1}{6} b \right) Fb^2 \frac{1}{EJ} = -\frac{1}{24} Fb^3/EJ$$

$$L_{CD}^{xo} = \int_0^b \left(\frac{1}{4} - \frac{1}{2} \frac{x}{b} + \frac{1}{4} \frac{x^2}{b^2} \right) Fb^2 \frac{1}{EJ} dx + \int_0^b \left(\frac{1}{2} - \frac{1}{2} \frac{x}{b} \right) \theta dx$$

$$= \left[\frac{1}{4} x - \frac{1}{4} \frac{x^2}{b} + \frac{1}{12} \frac{x^3}{b^2} \right]_0^b Fb^2 \frac{1}{EJ} + \left[\frac{1}{2} x - \frac{1}{4} \frac{x^2}{b} \right]_0^b \theta$$

$$= \left(\frac{1}{4} b - \frac{1}{4} b + \frac{1}{12} b \right) Fb^2 \frac{1}{EJ} + \left(\frac{1}{2} b - \frac{1}{4} b \right) \theta = \frac{1}{3} Fb^3/EJ$$

$$L_{DC}^{xo} = \int_0^b \left(\frac{1}{4} \frac{x^2}{b^2} \right) Fb^2 \frac{1}{EJ} dx + \int_0^b \left(-\frac{1}{2} \frac{x}{b} \right) \theta dx = \left[\frac{1}{12} \frac{x^3}{b^2} \right]_0^b Fb^2 \frac{1}{EJ} + \left[-\frac{1}{4} \frac{x^2}{b} \right]_0^b \theta$$

$$= \left(\frac{1}{12} b \right) Fb^2 \frac{1}{EJ} + \left(-\frac{1}{4} b \right) \theta = \frac{1}{3} Fb^3/EJ$$

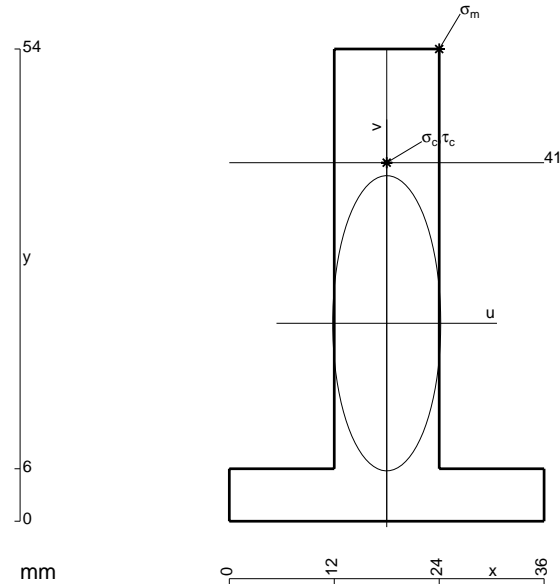

- A = 792. mm²
- J_u = 225759. mm⁴
- J_v = 30240. mm⁴
- y_g = 22.64 mm
- T_y = -3270. N
- M_x = 1716750. Nmm
- x_m = 24. mm
- y_m = 54. mm
- u_m = 6. mm
- v_m = 31.36 mm
- σ_m = -Mv/J_u = -238.5 N/mm²
- x_c = 18. mm
- y_c = 41. mm
- v_c = 18.36 mm
- σ_c = -Mv/J_u = -139.6 N/mm²
- τ_c = 4.682 N/mm²
- σ_o = √σ²+3τ² = 139.9 N/mm²
- S = 3879. mm³

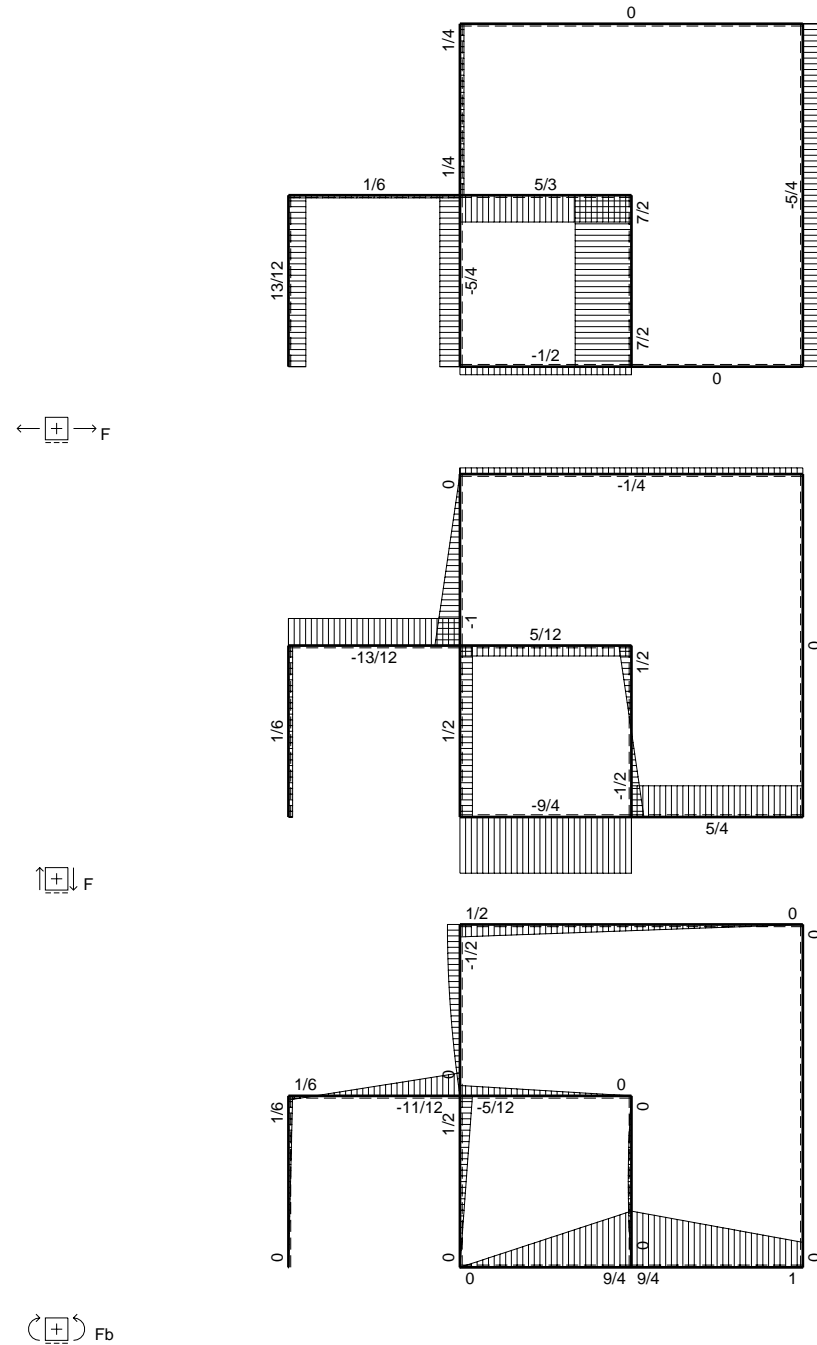
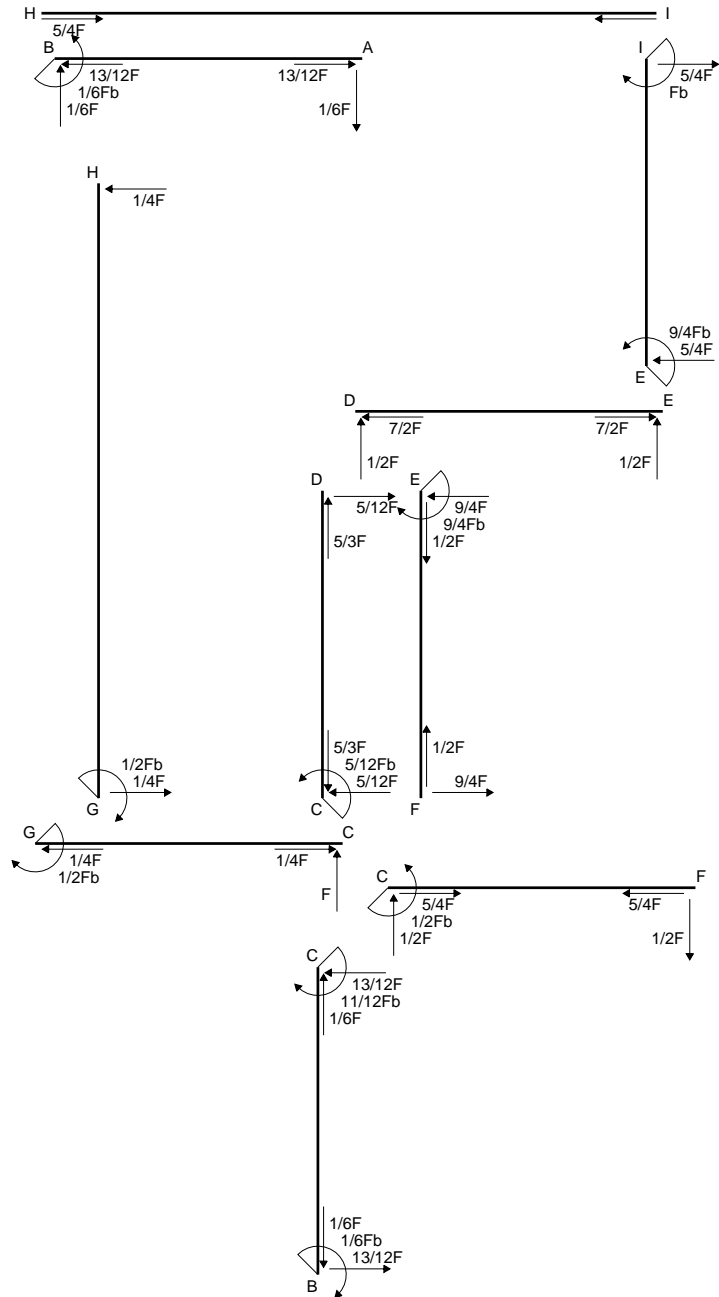

⊕ Fb

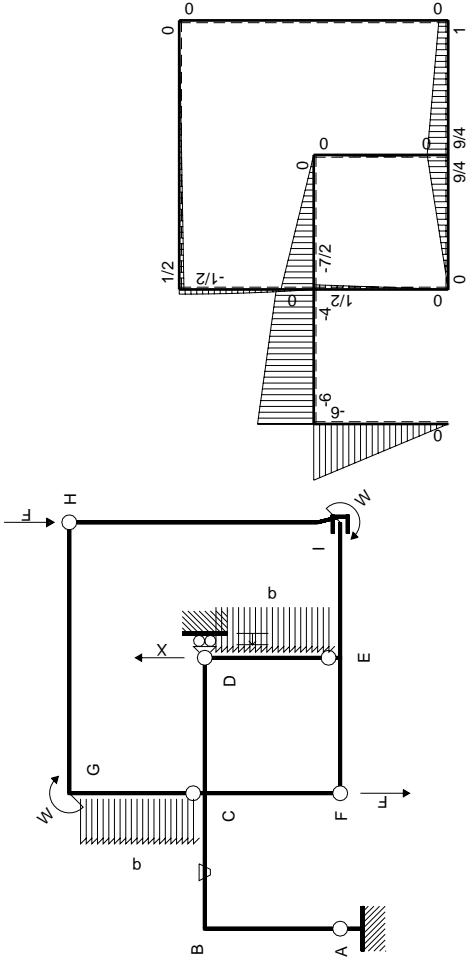

Schema di calcolo iperstatico

M_0 flessione da carichi assegnati

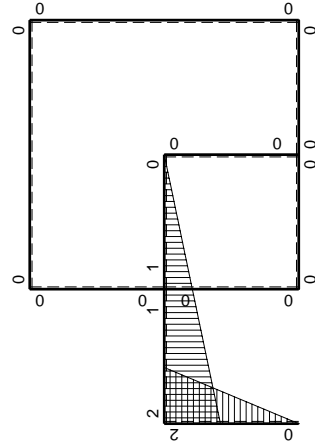

M_x flessione da iperstatica $X=1$

Quadro contributi PLV per iperstatica $X=V_D$

→	$M_x(x)$	$M_o(x)$	θ	$M_x M_o$	$M_x \theta$	$M_x M_x$	$\int M_x(M_o/EJ+\theta)dx$	$\int X M_x M_x/EJ dx$
AB b	2x	-6Fx	0	-12Fx ²	0	4x ²	(-4+0)Fb ³ /EJ	4/3Xb ³ /EJ
BA b	-2b+2x	6Fb-6Fx	0	-12Fb ² +24Fbx-12Fx ²	0	4b ² -8bx+4x ²		
BC b	2b-x	-6Fb+2Fx	-Fb/EJ	-12Fb ² +10Fbx-2Fx ²	-2Fb ² /EJ+Fxb/EJ	4b ² -4bx+x ²	(-23/3-3/2)Fb ³ /EJ	7/3Xb ³ /EJ
CB b	-b-x	4Fb+2Fx	Fb/EJ	-4Fb ² -6Fbx-2Fx ²	-Fb ² /EJ-Fxb/EJ	b ² +2bx+x ²		
CD b	b-x	-7/2Fb+7/2Fx	0	-7/2Fb ² +7Fbx-7/2Fx ²	0	b ² -2bx+x ²	(-7/6+0)Fb ³ /EJ	1/3Xb ³ /EJ
DC b	-x	7/2Fx	0	-7/2Fx ²	0	x ²		
DE b	0	1/2Fx-1/2qx ²	0	0	0	0	0+0	0
ED b	0	-1/2Fx+1/2qx ²	0	0	0	0		
EF b	0	9/4Fb-9/4Fx	0	0	0	0	0+0	0
FE b	0	-9/4Fx	0	0	0	0		
FC b	0	1/2Fx	0	0	0	0	0+0	0
CF b	0	-1/2Fb+1/2Fx	0	0	0	0		
CG b	0	-Fx+1/2qx ²	0	0	0	0	0+0	0
GC b	0	1/2Fb-1/2qx ²	0	0	0	0		
GH 2b	0	1/2Fb-1/4Fx	0	0	0	0	0+0	0
HG 2b	0	-1/4Fx	0	0	0	0		
HI 2b	0	0	0	0	0	0	0+0	0
IH 2b	0	0	0	0	0	0		
IE b	0	Fb+5/4Fx	0	0	0	0	0+0	0
EI b	0	-9/4Fb+5/4Fx	0	0	0	0		
D	cedimento nodo -H _{1D} u _D						2Fb ³ /EJ	
	totali						-37/3Fb ³ /EJ	4Xb ³ /EJ
	iperstatica X=V _D						37/12F	

Sviluppi di calcolo iperstatica

$$L_{AB}^{xx} = \int_0^b (4 x^2/b^2) b^2 1/EJ dx = [4/3 x^3/b^2]_0^b b^2 1/EJ$$

$$= (4/3 b) b^2 1/EJ = 4/3 b^3/EJ$$

$$L_{BA}^{xx} = \int_0^b (4 - 8 x/b + 4 x^2/b^2) b^2 1/EJ dx = [4 x - 4 x^2/b + 4/3 x^3/b^2]_0^b b^2 1/EJ$$

$$= (4 b - 4 b + 4/3 b) b^2 1/EJ = 4/3 b^3/EJ$$

$$L_{BC}^{xx} = \int_0^b (4 - 4 x/b + x^2/b^2) b^2 1/EJ dx = [4 x - 2 x^2/b + 1/3 x^3/b^2]_0^b b^2 1/EJ$$

$$= (4 b - 2 b + 1/3 b) b^2 1/EJ = 7/3 b^3/EJ$$

$$L_{CB}^{xx} = \int_0^b (1 + 2 x/b + x^2/b^2) b^2 1/EJ dx = [x + x^2/b + 1/3 x^3/b^2]_0^b b^2 1/EJ$$

$$= (b + b + 1/3 b) b^2 1/EJ = 7/3 b^3/EJ$$

$$L_{CD}^{xx} = \int_0^b (1 - 2 x/b + x^2/b^2) b^2 1/EJ dx = [x - x^2/b + 1/3 x^3/b^2]_0^b b^2 1/EJ$$

$$= (b - b + 1/3 b) b^2 1/EJ = 1/3 b^3/EJ$$

$$L_{DC}^{xx} = \int_0^b (x^2/b^2) b^2 1/EJ dx = [1/3 x^3/b^2]_0^b b^2 1/EJ$$

$$= (1/3 b) b^2 1/EJ = 1/3 b^3/EJ$$

$$L_{AB}^{x_0} = \int_0^b (-12 x^2/b^2) Fb^2 1/EJ dx = [-4 x^3/b^2]_0^b Fb^2 1/EJ$$

$$= (-4 b) Fb^2 1/EJ = -4 Fb^3/EJ$$

$$L_{BA}^{x_0} = \int_0^b (-12 + 24 x/b - 12 x^2/b^2) Fb^2 1/EJ dx = [-12 x + 12 x^2/b - 4 x^3/b^2]_0^b Fb^2 1/EJ$$

$$= (-12 b + 12 b - 4 b) Fb^2 1/EJ = -4 Fb^3/EJ$$

$$L_{BC}^{x_0} = \int_0^b (-12 + 10 x/b - 2 x^2/b^2) Fb^2 1/EJ dx + \int_0^b (-2 + x/b) \theta dx$$

$$= [-12 x + 5 x^2/b - 2/3 x^3/b^2]_0^b Fb^2 1/EJ + [-2 x + 1/2 x^2/b]_0^b \theta$$

$$= (-12 b + 5 b - 2/3 b) Fb^2 1/EJ + (-2 b + 1/2 b) \theta = -55/6 Fb^3/EJ$$

$$L_{CB}^{x_0} = \int_0^b (-4 - 6 x/b - 2 x^2/b^2) Fb^2 1/EJ dx + \int_0^b (1 + x/b) \theta dx$$

$$= [-4 x - 3 x^2/b - 2/3 x^3/b^2]_0^b Fb^2 1/EJ + [x + 1/2 x^2/b]_0^b \theta$$

$$= (-4 b - 3 b - 2/3 b) Fb^2 1/EJ + (b + 1/2 b) \theta = -55/6 Fb^3/EJ$$

$$L_{CD}^{x_0} = \int_0^b (-7/2 + 7 x/b - 7/2 x^2/b^2) Fb^2 1/EJ dx = [-7/2 x + 7/2 x^2/b - 7/6 x^3/b^2]_0^b Fb^2 1/EJ$$

$$= (-7/2 b + 7/2 b - 7/6 b) Fb^2 1/EJ = -7/6 Fb^3/EJ$$

$$L_{DC}^{x_0} = \int_0^b (-7/2 x^2/b^2) Fb^2 1/EJ dx = [-7/6 x^3/b^2]_0^b Fb^2 1/EJ$$

$$= (-7/6 b) Fb^2 1/EJ = -7/6 Fb^3/EJ$$

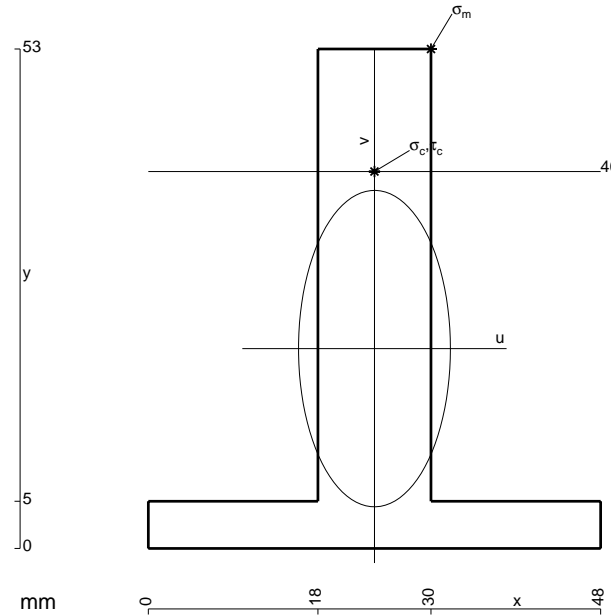

- A = 816. mm²
- J_u = 230061. mm⁴
- J_v = 52992. mm⁴
- y_g = 21.21 mm
- N = -475. N
- T_y = -2138. N
- M_x = 1581750. Nmm
- x_m = 30. mm
- y_m = 53. mm
- u_m = 6. mm
- v_m = 31.79 mm
- σ_m = N/A-Mv/J_u = -219.2 N/mm²
- x_c = 24. mm
- y_c = 40. mm
- v_c = 18.79 mm
- σ_c = N/A-Mv/J_u = -129.8 N/mm²
- τ_c = 3.055 N/mm²
- σ₀ = √σ²+3τ² = 129.9 N/mm²
- S = 3946. mm³

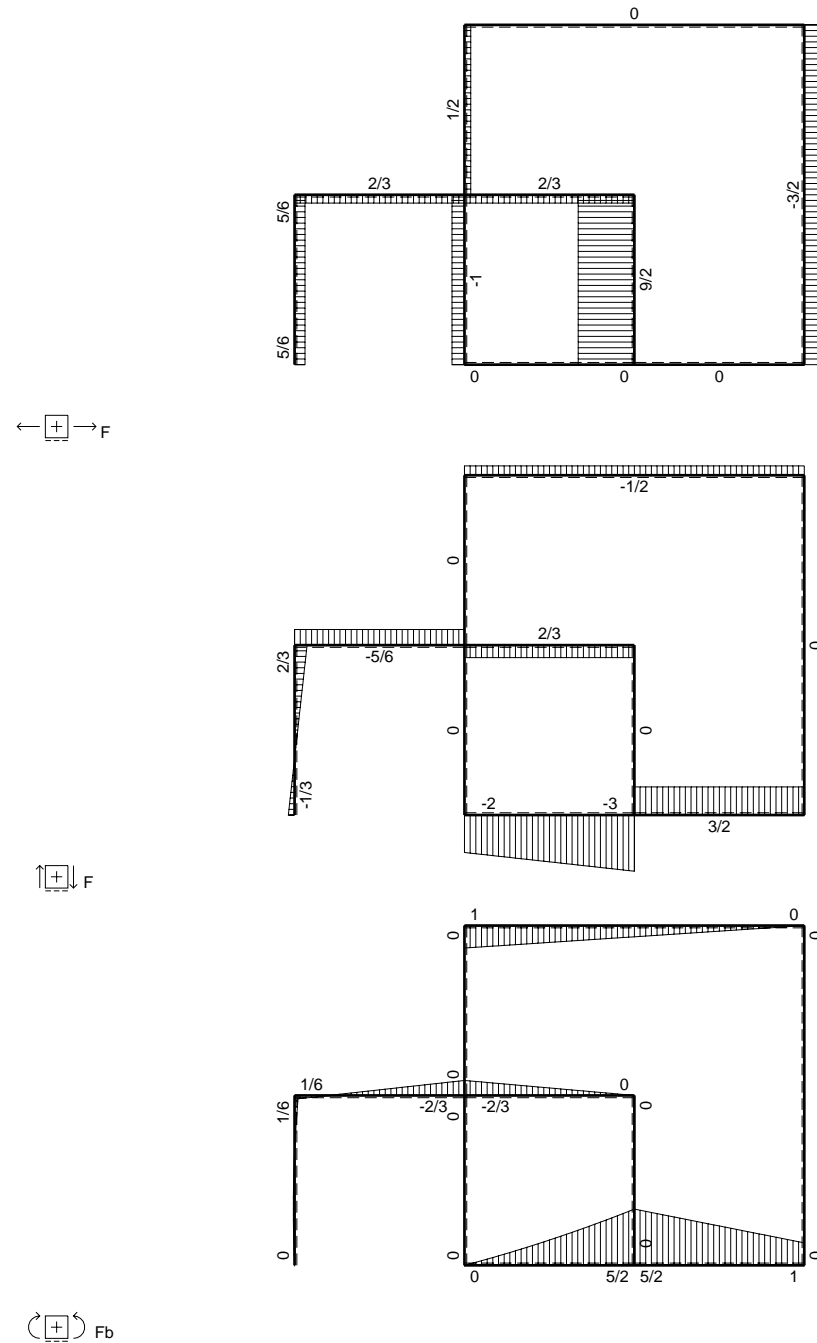
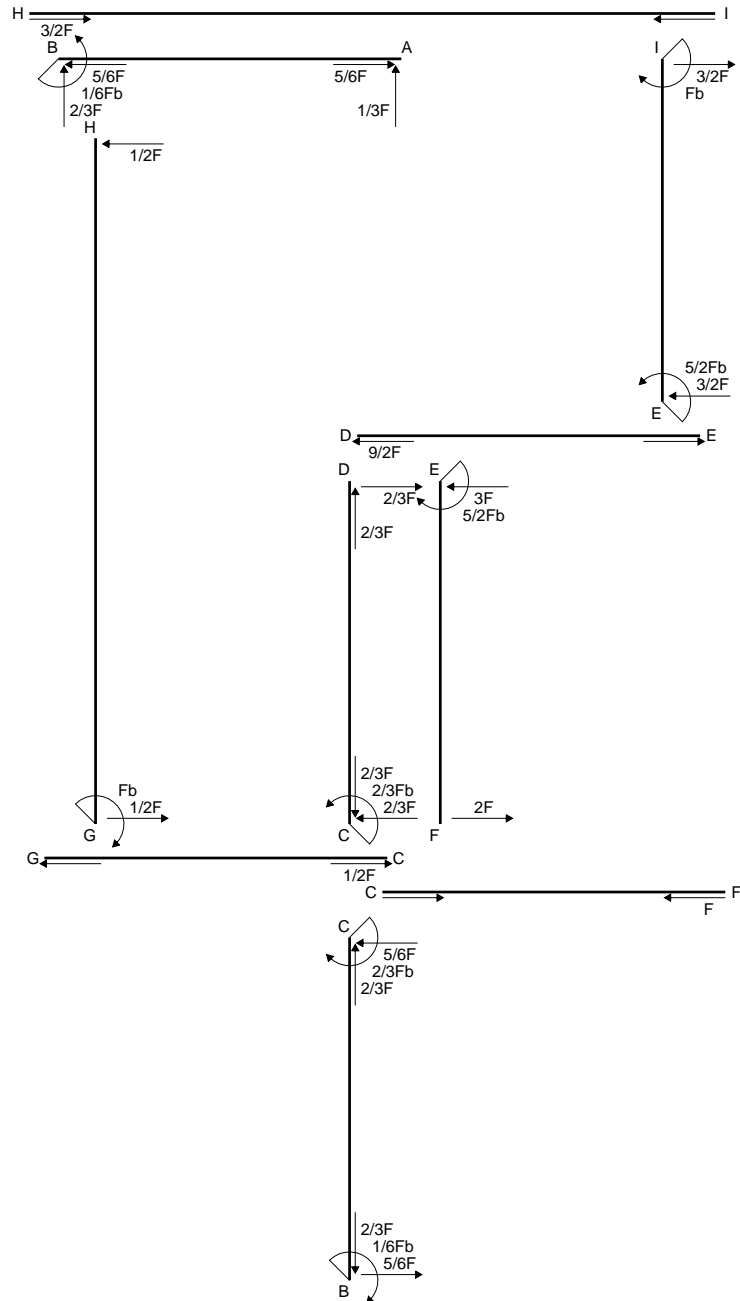

$\left[\begin{matrix} + \\ - \end{matrix} \right] F_b$

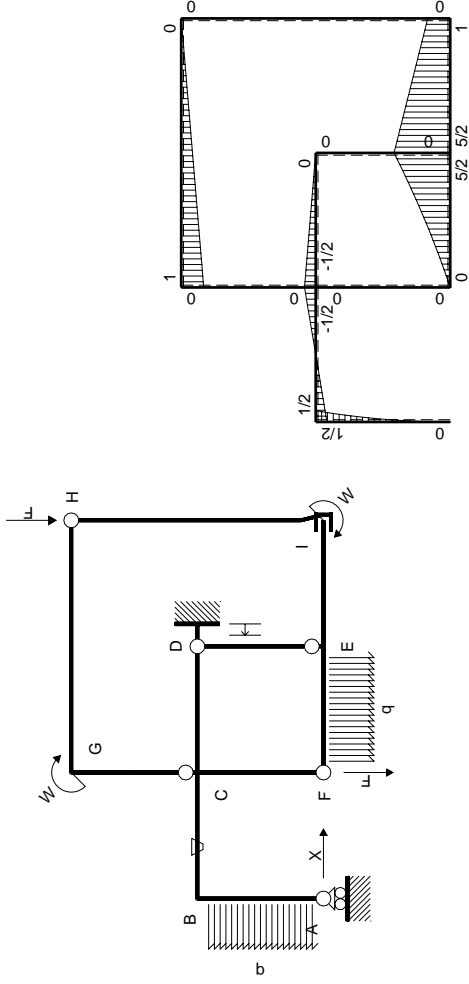

Schema di calcolo iperstatico

M_0 flessione da carichi assegnati



M_x flessione da iperstatica X=1

Quadro contributi PLV per iperstatica $X=H_A$

→	$M_x(x)$	$M_o(x)$	θ	$M_x M_o$	$M_x \theta$	$M_x M_x$	$\int M_x(M_o/EJ+\theta)dx$	$\int X M_x M_x / EJ dx$	
AB b	-x	$1/2qx^2$	0	$-1/2qx^3$	0	x^2	$(-1/8+0)Fb^3/EJ$	$1/3Xb^3/EJ$	
BA b	b-x	$-1/2Fb+Fx-1/2qx^2$	0	$-1/2Fb^2+3/2Fbx-3/2Fx^2+1/2qx^3$	0	$b^2-2bx+x^2$			
BC b	-b+1/2x	$1/2Fb-Fx$	$-Fb/EJ$	$-1/2Fb^2+5/4Fbx-1/2Fx^2$	$Fb^2/EJ-1/2Fxb/EJ$	$b^2-bx+1/4x^2$	$(-1/24+3/4)Fb^3/EJ$	$7/12Xb^3/EJ$	
CB b	$1/2b+1/2x$	$1/2Fb-Fx$	Fb/EJ	$1/4Fb^2-1/4Fbx-1/2Fx^2$	$1/2Fb^2/EJ+1/2Fxb/EJ$	$1/4b^2+1/2bx+1/4x^2$			
CD b	$-1/2b+1/2x$	$-1/2Fb+1/2Fx$	0	$1/4Fb^2-1/2Fbx+1/4Fx^2$	0	$1/4b^2-1/2bx+1/4x^2$	$(1/12+0)Fb^3/EJ$	$1/12Xb^3/EJ$	
DC b	$1/2x$	$1/2Fx$	0	$1/4Fx^2$	0	$1/4x^2$			
DE b	0	0	0	0	0	0	0+0	0	
ED b	0	0	0	0	0	0			
EF b	0	$5/2Fb-3Fx+1/2qx^2$	0	0	0	0	0+0	0	
FE b	0	$-2Fx-1/2qx^2$	0	0	0	0			
FC b	0	0	0	0	0	0	0+0	0	
CF b	0	0	0	0	0	0			
CG b	0	0	0	0	0	0	0+0	0	
GC b	0	0	0	0	0	0			
GH 2b	0	$Fb-1/2Fx$	0	0	0	0	0+0	0	
HG 2b	0	$-1/2Fx$	0	0	0	0			
HI 2b	0	0	0	0	0	0	0+0	0	
IH 2b	0	0	0	0	0	0			
IE b	0	$Fb+3/2Fx$	0	0	0	0	0+0	0	
EI b	0	$-5/2Fb+3/2Fx$	0	0	0	0			
D	cedimento nodo $-H_{1D}u_D$							$-Fb^3/EJ$	
	totali							$-1/3Fb^3/EJ$	Xb^3/EJ
	iperstatica $X=H_A$							$1/3F$	

Sviluppi di calcolo iperstatica

$$L_{AB}^{xx} = \int_0^b (x^2/b^2) b^2 1/EJ dx = [1/3 x^3/b^2]_0^b b^2 1/EJ$$

$$= (1/3 b) b^2 1/EJ = 1/3 b^3/EJ$$

$$L_{BA}^{xx} = \int_0^b (1 - 2x/b + x^2/b^2) b^2 1/EJ dx = [x - x^2/b + 1/3 x^3/b^2]_0^b b^2 1/EJ$$

$$= (b - b + 1/3 b) b^2 1/EJ = 1/3 b^3/EJ$$

$$L_{BC}^{xx} = \int_0^b (1 - x/b + 1/4 x^2/b^2) b^2 1/EJ dx = [x - 1/2 x^2/b + 1/12 x^3/b^2]_0^b b^2 1/EJ$$

$$= (b - 1/2 b + 1/12 b) b^2 1/EJ = 7/12 b^3/EJ$$

$$L_{CB}^{xx} = \int_0^b (1/4 + 1/2 x/b + 1/4 x^2/b^2) b^2 1/EJ dx = [1/4 x + 1/4 x^2/b + 1/12 x^3/b^2]_0^b b^2 1/EJ$$

$$= (1/4 b + 1/4 b + 1/12 b) b^2 1/EJ = 7/12 b^3/EJ$$

$$L_{CD}^{xx} = \int_0^b (1/4 - 1/2 x/b + 1/4 x^2/b^2) b^2 1/EJ dx = [1/4 x - 1/4 x^2/b + 1/12 x^3/b^2]_0^b b^2 1/EJ$$

$$= (1/4 b - 1/4 b + 1/12 b) b^2 1/EJ = 1/12 b^3/EJ$$

$$L_{DC}^{xx} = \int_0^b (1/4 x^2/b^2) b^2 1/EJ dx = [1/12 x^3/b^2]_0^b b^2 1/EJ$$

$$= (1/12 b) b^2 1/EJ = 1/12 b^3/EJ$$

$$L_{AB}^{x_0} = \int_0^b (-1/2 x^3/b^3) Fb^2 1/EJ dx = [-1/8 x^4/b^3]_0^b Fb^2 1/EJ$$

$$= (-1/8 b) Fb^2 1/EJ = -1/8 Fb^3/EJ$$

$$L_{BA}^{x_0} = \int_0^b (-1/2 + 3/2 x/b - 3/2 x^2/b^2 + 1/2 x^3/b^3) Fb^2 1/EJ dx$$

$$= [-1/2 x + 3/4 x^2/b - 1/2 x^3/b^2 + 1/8 x^4/b^3]_0^b Fb^2 1/EJ$$

$$= (-1/2 b + 3/4 b - 1/2 b + 1/8 b) Fb^2 1/EJ = -1/8 Fb^3/EJ$$

$$L_{BC}^{x_0} = \int_0^b (-1/2 + 5/4 x/b - 1/2 x^2/b^2) Fb^2 1/EJ dx + \int_0^b (1 - 1/2 x/b) \theta dx$$

$$= [-1/2 x + 5/8 x^2/b - 1/6 x^3/b^2]_0^b Fb^2 1/EJ + [x - 1/4 x^2/b]_0^b \theta$$

$$= (-1/2 b + 5/8 b - 1/6 b) Fb^2 1/EJ + (b - 1/4 b) \theta = 17/24 Fb^3/EJ$$

$$L_{CB}^{x_0} = \int_0^b (1/4 - 1/4 x/b - 1/2 x^2/b^2) Fb^2 1/EJ dx + \int_0^b (-1/2 - 1/2 x/b) \theta dx$$

$$= [1/4 x - 1/8 x^2/b - 1/6 x^3/b^2]_0^b Fb^2 1/EJ + [-1/2 x - 1/4 x^2/b]_0^b \theta$$

$$= (1/4 b - 1/8 b - 1/6 b) Fb^2 1/EJ + (-1/2 b - 1/4 b) \theta = 17/24 Fb^3/EJ$$

$$L_{CD}^{x_0} = \int_0^b (1/4 - 1/2 x/b + 1/4 x^2/b^2) Fb^2 1/EJ dx = [1/4 x - 1/4 x^2/b + 1/12 x^3/b^2]_0^b Fb^2 1/EJ$$

$$= (1/4 b - 1/4 b + 1/12 b) Fb^2 1/EJ = 1/12 Fb^3/EJ$$

$$L_{DC}^{x_0} = \int_0^b (1/4 x^2/b^2) Fb^2 1/EJ dx = [1/12 x^3/b^2]_0^b Fb^2 1/EJ$$

$$= (1/12 b) Fb^2 1/EJ = 1/12 Fb^3/EJ$$

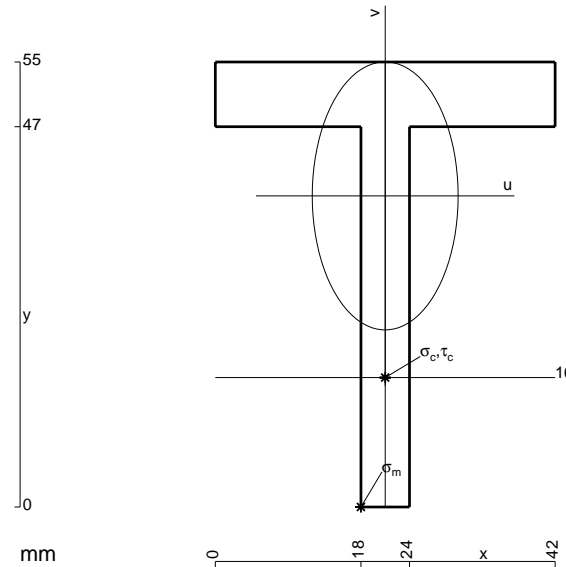

- A = 618. mm²
- J_u = 169652. mm⁴
- J_v = 50238. mm⁴
- y_g = 38.45 mm
- T_y = -2070. N
- M_x = 1000500. Nmm
- x_m = 18. mm
- u_m = -3. mm
- v_m = -38.45 mm
- σ_m = -Mv/J_u = 226.8 N/mm²
- x_c = 21. mm
- y_c = 16. mm
- v_c = -22.45 mm
- σ_c = -Mv/J_u = 132.4 N/mm²
- τ_c = 5.945 N/mm²
- σ_q = √σ² + 3τ² = 132.8 N/mm²
- S = 2923. mm³

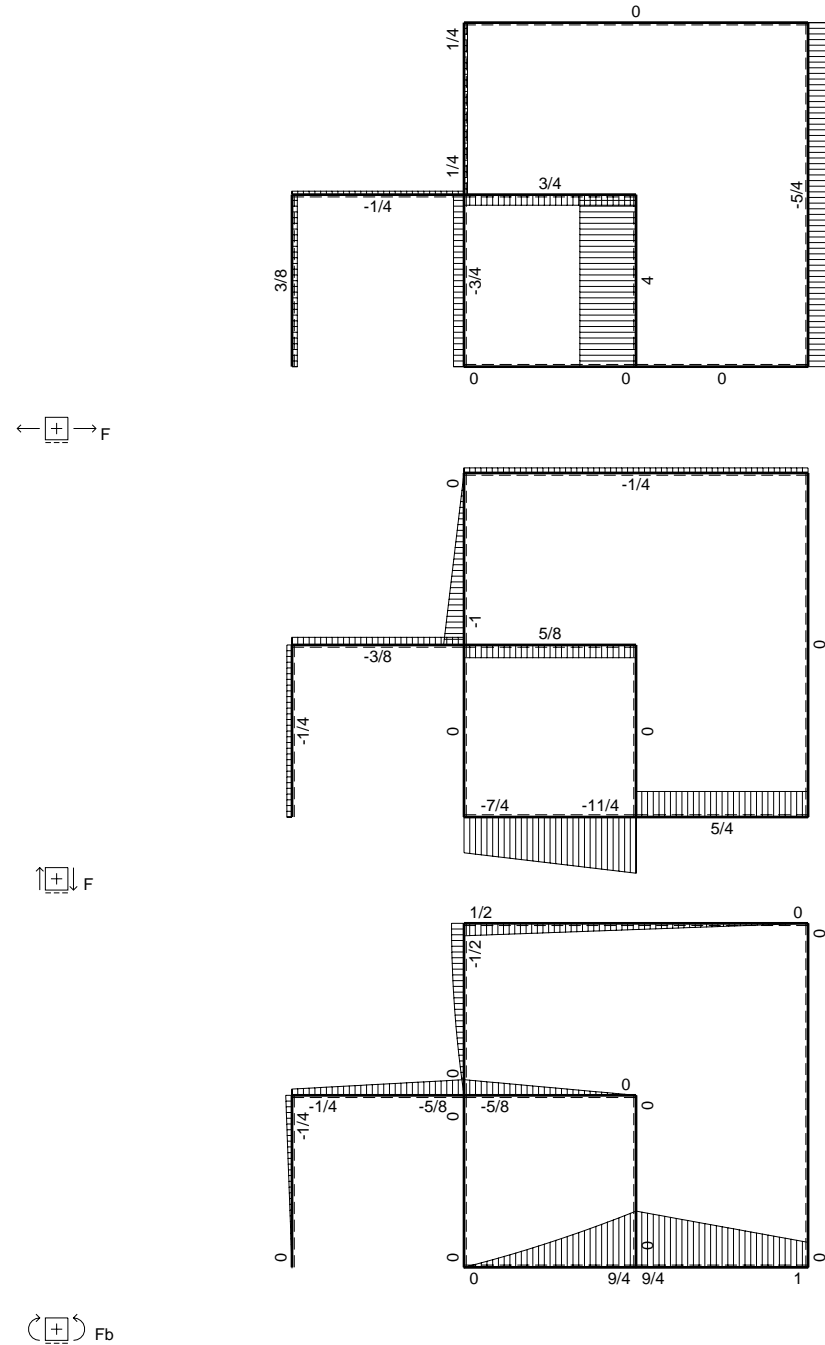
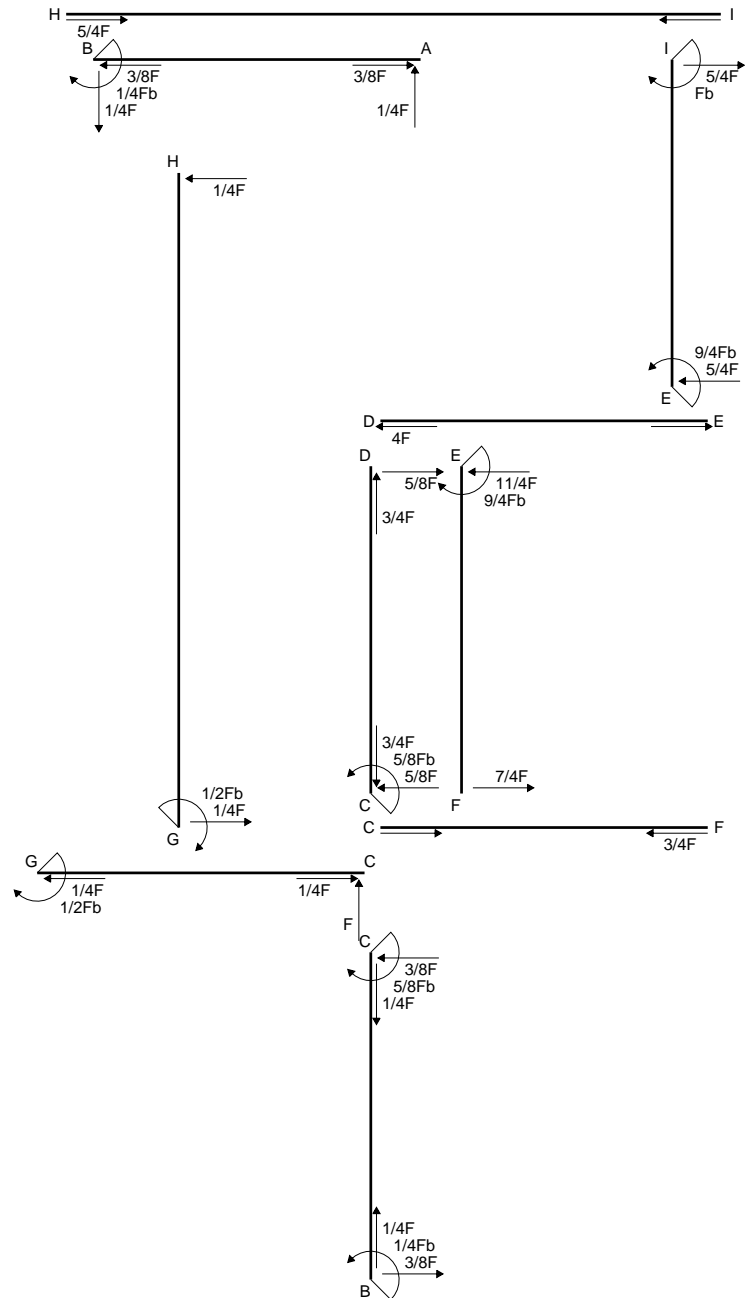

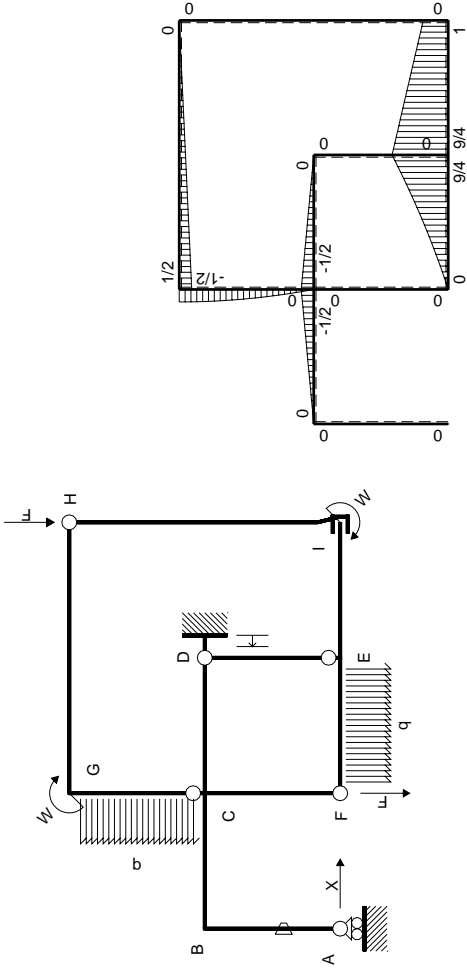

Schema di calcolo iperstatico

M_0 flessione da carichi assegnati



M_x flessione da iperstatica $X=1$

Quadro contributi PLV per iperstatica $X=H_A$

→	$M_x(x)$	$M_o(x)$	θ	$M_x M_o$	$M_x \theta$	$M_x M_x$	$\int M_x(M_o/EJ+\theta)dx$	$\int X M_x M_x/EJ dx$	
AB b	-x	0	-Fb/EJ	0	Fxb/EJ	x^2	$(0+1/2)Fb^3/EJ$	$1/3Xb^3/EJ$	
BA b	b-x	0	Fb/EJ	0	$Fb^2/EJ-Fxb/EJ$	$b^2-2bx+x^2$			
BC b	-b+1/2x	-1/2Fx	0	$1/2Fbx-1/4Fx^2$	0	$b^2-bx+1/4x^2$	$(1/6+0)Fb^3/EJ$	$7/12Xb^3/EJ$	
CB b	$1/2b+1/2x$	$1/2Fb-1/2Fx$	0	$1/4Fb^2-1/4Fx^2$	0	$1/4b^2+1/2bx+1/4x^2$			
CD b	-1/2b+1/2x	-1/2Fb+1/2Fx	0	$1/4Fb^2-1/2Fbx+1/4Fx^2$	0	$1/4b^2-1/2bx+1/4x^2$	$(1/12+0)Fb^3/EJ$	$1/12Xb^3/EJ$	
DC b	1/2x	1/2Fx	0	$1/4Fx^2$	0	$1/4x^2$			
DE b	0	0	0	0	0	0	0+0	0	
ED b	0	0	0	0	0	0			
EF b	0	$9/4Fb-11/4Fx+1/2qx^2$	0	0	0	0	0+0	0	
FE b	0	$-7/4Fx-1/2qx^2$	0	0	0	0			
FC b	0	0	0	0	0	0	0+0	0	
CF b	0	0	0	0	0	0			
CG b	0	$-Fx+1/2qx^2$	0	0	0	0	0+0	0	
GC b	0	$1/2Fb-1/2qx^2$	0	0	0	0			
GH 2b	0	$1/2Fb-1/4Fx$	0	0	0	0	0+0	0	
HG 2b	0	-1/4Fx	0	0	0	0			
HI 2b	0	0	0	0	0	0	0+0	0	
IH 2b	0	0	0	0	0	0			
IE b	0	$Fb+5/4Fx$	0	0	0	0	0+0	0	
EI b	0	$-9/4Fb+5/4Fx$	0	0	0	0			
D	cedimento nodo $-H_{1D}u_D$							$-Fb^3/EJ$	
	totali							$-1/4Fb^3/EJ$	Xb^3/EJ
	iperstatica $X=H_A$							1/4F	

Sviluppi di calcolo iperstatica

$$L_{AB}^{xx} = \int_0^b (x^2/b^2) b^2 1/EJ dx = [1/3 x^3/b^2]_0^b b^2 1/EJ$$

$$= (1/3 b) b^2 1/EJ = 1/3 b^3/EJ$$

$$L_{BA}^{xx} = \int_0^b (1 - 2x/b + x^2/b^2) b^2 1/EJ dx = [x - x^2/b + 1/3 x^3/b^2]_0^b b^2 1/EJ$$

$$= (b - b + 1/3 b) b^2 1/EJ = 1/3 b^3/EJ$$

$$L_{BC}^{xx} = \int_0^b (1 - x/b + 1/4 x^2/b^2) b^2 1/EJ dx = [x - 1/2 x^2/b + 1/12 x^3/b^2]_0^b b^2 1/EJ$$

$$= (b - 1/2 b + 1/12 b) b^2 1/EJ = 7/12 b^3/EJ$$

$$L_{CB}^{xx} = \int_0^b (1/4 + 1/2 x/b + 1/4 x^2/b^2) b^2 1/EJ dx = [1/4 x + 1/4 x^2/b + 1/12 x^3/b^2]_0^b b^2 1/EJ$$

$$= (1/4 b + 1/4 b + 1/12 b) b^2 1/EJ = 7/12 b^3/EJ$$

$$L_{CD}^{xx} = \int_0^b (1/4 - 1/2 x/b + 1/4 x^2/b^2) b^2 1/EJ dx = [1/4 x - 1/4 x^2/b + 1/12 x^3/b^2]_0^b b^2 1/EJ$$

$$= (1/4 b - 1/4 b + 1/12 b) b^2 1/EJ = 1/12 b^3/EJ$$

$$L_{DC}^{xx} = \int_0^b (1/4 x^2/b^2) b^2 1/EJ dx = [1/12 x^3/b^2]_0^b b^2 1/EJ$$

$$= (1/12 b) b^2 1/EJ = 1/12 b^3/EJ$$

$$L_{AB}^{xo} = \int_0^b (x/b) \theta dx = [1/2 x^2/b]_0^b \theta$$

$$= (1/2 b) \theta = 1/2 Fb^3/EJ$$

$$L_{BA}^{xo} = \int_0^b (-1 + x/b) \theta dx = [-x + 1/2 x^2/b]_0^b \theta$$

$$= (-b + 1/2 b) \theta = 1/2 Fb^3/EJ$$

$$L_{BC}^{xo} = \int_0^b (1/2 x/b - 1/4 x^2/b^2) Fb^2 1/EJ dx = [1/4 x^2/b - 1/12 x^3/b^2]_0^b Fb^2 1/EJ$$

$$= (1/4 b - 1/12 b) Fb^2 1/EJ = 1/6 Fb^3/EJ$$

$$L_{CB}^{xo} = \int_0^b (1/4 - 1/4 x^2/b^2) Fb^2 1/EJ dx = [1/4 x - 1/12 x^3/b^2]_0^b Fb^2 1/EJ$$

$$= (1/4 b - 1/12 b) Fb^2 1/EJ = 1/6 Fb^3/EJ$$

$$L_{CD}^{xo} = \int_0^b (1/4 - 1/2 x/b + 1/4 x^2/b^2) Fb^2 1/EJ dx = [1/4 x - 1/4 x^2/b + 1/12 x^3/b^2]_0^b Fb^2 1/EJ$$

$$= (1/4 b - 1/4 b + 1/12 b) Fb^2 1/EJ = 1/12 Fb^3/EJ$$

$$L_{DC}^{xo} = \int_0^b (1/4 x^2/b^2) Fb^2 1/EJ dx = [1/12 x^3/b^2]_0^b Fb^2 1/EJ$$

$$= (1/12 b) Fb^2 1/EJ = 1/12 Fb^3/EJ$$

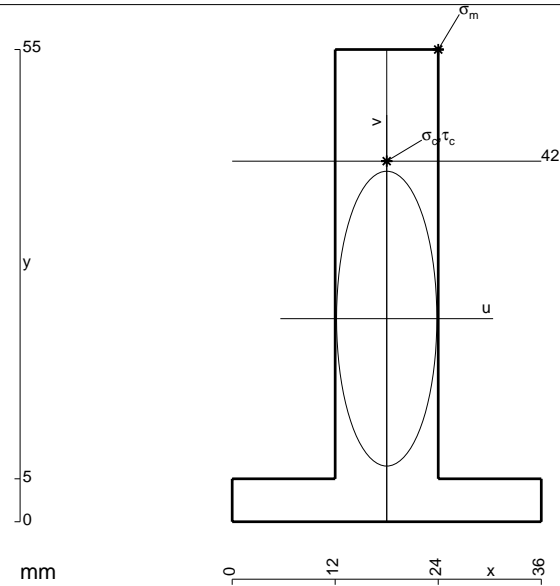

- A = 780. mm²
- J_u = 230087. mm⁴
- J_v = 26640. mm⁴
- y_g = 23.65 mm
- T_y = -2613. N
- M_x = 1539000. Nmm
- x_m = 24. mm
- y_m = 55. mm
- u_m = 6. mm
- v_m = 31.35 mm
- σ_m = -Mv/J_u = -209.7 N/mm²
- x_c = 18. mm
- y_c = 42. mm
- v_c = 18.35 mm
- σ_c = -Mv/J_u = -122.7 N/mm²
- τ_c = 3.667 N/mm²
- σ_q = √σ²+3τ² = 122.9 N/mm²
- S = 3876. mm³

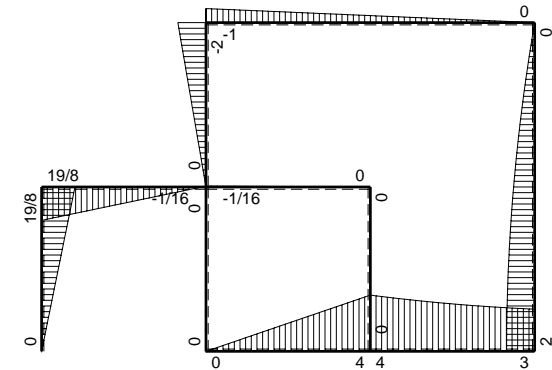
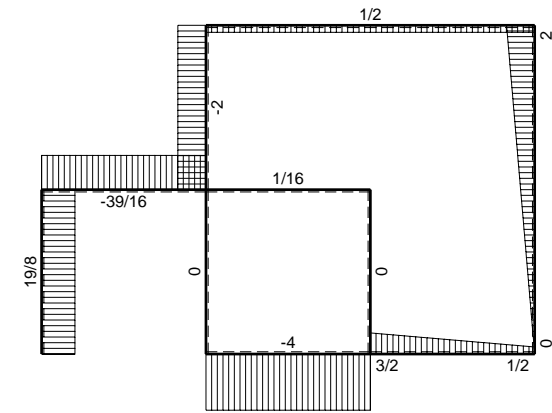
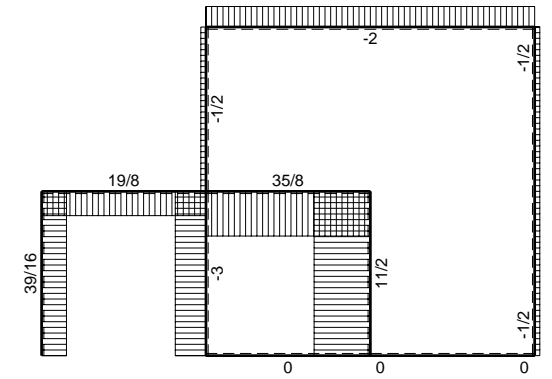
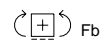
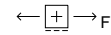
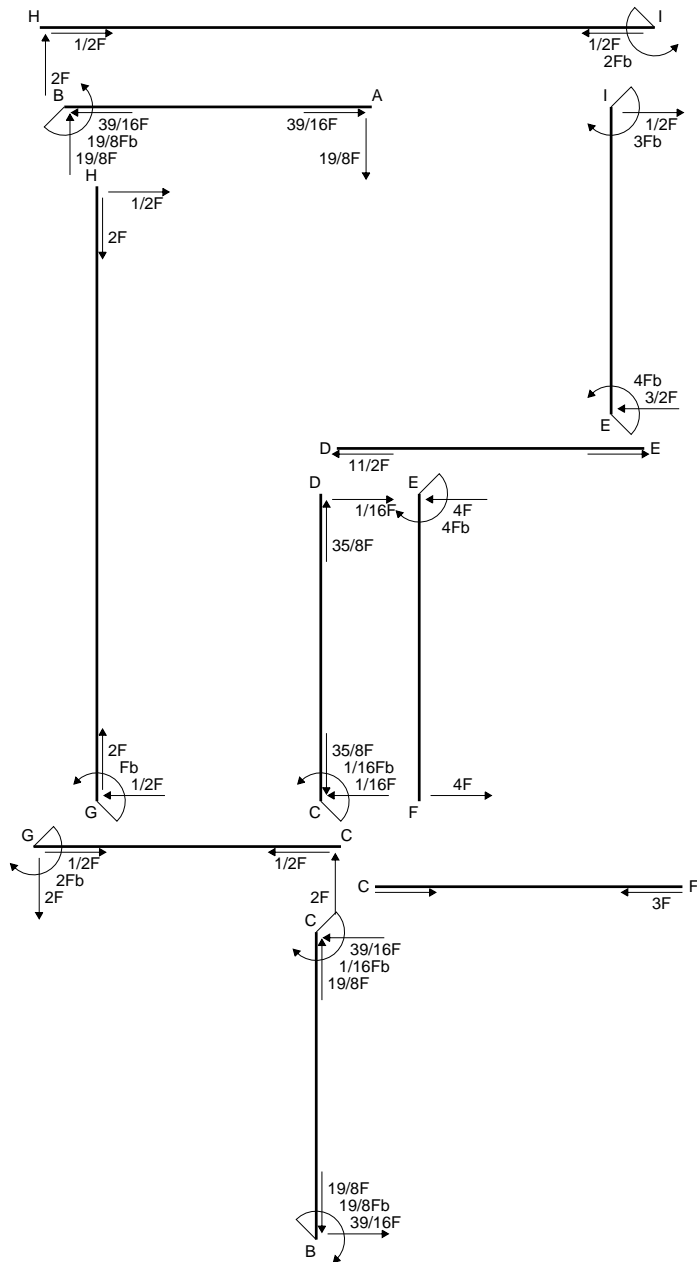

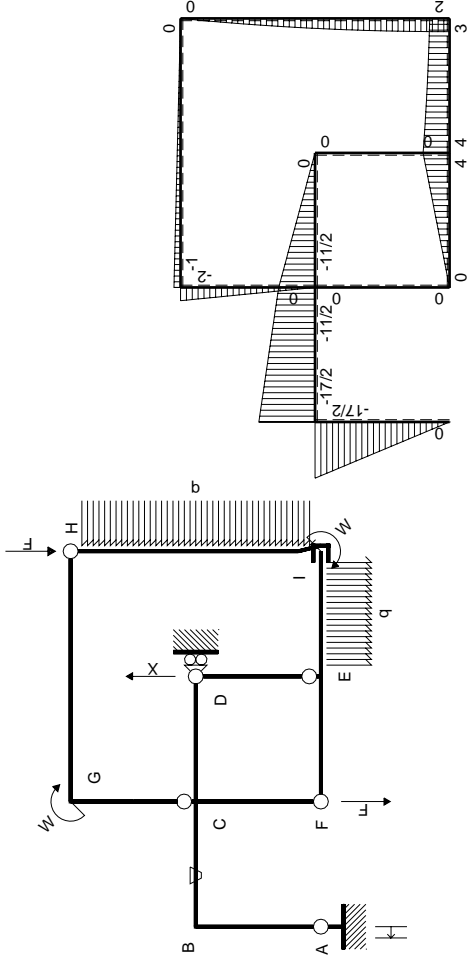

Schema di calcolo iperstatico

M_0 flessione da carichi assegnati

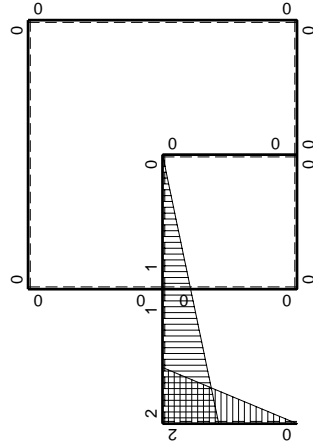

M_x flessione da iperstatica X=1

Quadro contributi PLV per iperstatica $X=V_D$

→	$M_x(x)$	$M_o(x)$	θ	$M_x M_o$	$M_x \theta$	$M_x M_x$	$\int M_x(M_o/EJ+\theta)dx$	$\int X M_x M_x / EJ dx$	
AB b	2x	-17/2Fx	0	-17Fx ²	0	4x ²	(-17/3+0)Fb ³ /EJ	4/3Xb ³ /EJ	
BA b	-2b+2x	17/2Fb-17/2Fx	0	-17Fb ² +34Fbx-17Fx ²	0	4b ² -8bx+4x ²			
BC b	2b-x	-17/2Fb+3Fx	-Fb/EJ	-17Fb ² +29/2Fbx-3Fx ²	-2Fb ² /EJ+Fxb/EJ	4b ² -4bx+x ²	(-43/4-3/2)Fb ³ /EJ	7/3Xb ³ /EJ	
CB b	-b-x	11/2Fb+3Fx	Fb/EJ	-11/2Fb ² -17/2Fbx-3Fx ²	-Fb ² /EJ-Fxb/EJ	b ² +2bx+x ²			
CD b	b-x	-11/2Fb+11/2Fx	0	-11/2Fb ² +11Fbx-11/2Fx ²	0	b ² -2bx+x ²	(-11/6+0)Fb ³ /EJ	1/3Xb ³ /EJ	
DC b	-x	11/2Fx	0	-11/2Fx ²	0	x ²			
DE b	0	0	0	0	0	0	0+0	0	
ED b	0	0	0	0	0	0			
EF b	0	4Fb-4Fx	0	0	0	0	0+0	0	
FE b	0	-4Fx	0	0	0	0			
FC b	0	0	0	0	0	0	0+0	0	
CF b	0	0	0	0	0	0			
CG b	0	-2Fx	0	0	0	0	0+0	0	
GC b	0	2Fb-2Fx	0	0	0	0			
GH 2b	0	-Fb+1/2Fx	0	0	0	0	0+0	0	
HG 2b	0	1/2Fx	0	0	0	0			
HI 2b	0	2Fx-1/2qx ²	0	0	0	0	0+0	0	
IH 2b	0	-2Fb+1/2qx ²	0	0	0	0			
IE b	0	3Fb+1/2Fx+1/2qx ²	0	0	0	0	0+0	0	
EI b	0	-4Fb+3/2Fx-1/2qx ²	0	0	0	0			
A	cedimento nodo -H _{1A} u _A							-2Fb ³ /EJ	
	totali							-87/4Fb ³ /EJ	4Xb ³ /EJ
	iperstatica X=V _D							87/16F	

Sviluppi di calcolo iperstatica

$$L_{AB}^{xx} = \int_0^b (4 x^2/b^2) b^2 1/EJ dx = [4/3 x^3/b^2]_0^b b^2 1/EJ$$

$$= (4/3 b) b^2 1/EJ = 4/3 b^3/EJ$$

$$L_{BA}^{xx} = \int_0^b (4 - 8 x/b + 4 x^2/b^2) b^2 1/EJ dx = [4 x - 4 x^2/b + 4/3 x^3/b^2]_0^b b^2 1/EJ$$

$$= (4 b - 4 b + 4/3 b) b^2 1/EJ = 4/3 b^3/EJ$$

$$L_{BC}^{xx} = \int_0^b (4 - 4 x/b + x^2/b^2) b^2 1/EJ dx = [4 x - 2 x^2/b + 1/3 x^3/b^2]_0^b b^2 1/EJ$$

$$= (4 b - 2 b + 1/3 b) b^2 1/EJ = 7/3 b^3/EJ$$

$$L_{CB}^{xx} = \int_0^b (1 + 2 x/b + x^2/b^2) b^2 1/EJ dx = [x + x^2/b + 1/3 x^3/b^2]_0^b b^2 1/EJ$$

$$= (b + b + 1/3 b) b^2 1/EJ = 7/3 b^3/EJ$$

$$L_{CD}^{xx} = \int_0^b (1 - 2 x/b + x^2/b^2) b^2 1/EJ dx = [x - x^2/b + 1/3 x^3/b^2]_0^b b^2 1/EJ$$

$$= (b - b + 1/3 b) b^2 1/EJ = 1/3 b^3/EJ$$

$$L_{DC}^{xx} = \int_0^b (x^2/b^2) b^2 1/EJ dx = [1/3 x^3/b^2]_0^b b^2 1/EJ$$

$$= (1/3 b) b^2 1/EJ = 1/3 b^3/EJ$$

$$L_{AB}^{xo} = \int_0^b (-17 x^2/b^2) Fb^2 1/EJ dx = [-17/3 x^3/b^2]_0^b Fb^2 1/EJ$$

$$= (-17/3 b) Fb^2 1/EJ = -17/3 Fb^3/EJ$$

$$L_{BA}^{xo} = \int_0^b (-17 + 34 x/b - 17 x^2/b^2) Fb^2 1/EJ dx = [-17 x + 17 x^2/b - 17/3 x^3/b^2]_0^b Fb^2 1/EJ$$

$$= (-17 b + 17 b - 17/3 b) Fb^2 1/EJ = -17/3 Fb^3/EJ$$

$$L_{BC}^{xo} = \int_0^b (-17 + 29/2 x/b - 3 x^2/b^2) Fb^2 1/EJ dx + \int_0^b (-2 + x/b) \theta dx$$

$$= [-17 x + 29/4 x^2/b - x^3/b^2]_0^b Fb^2 1/EJ + [-2 x + 1/2 x^2/b]_0^b \theta$$

$$= (-17 b + 29/4 b - b) Fb^2 1/EJ + (-2 b + 1/2 b) \theta = -49/4 Fb^3/EJ$$

$$L_{CB}^{xo} = \int_0^b (-11/2 - 17/2 x/b - 3 x^2/b^2) Fb^2 1/EJ dx + \int_0^b (1 + x/b) \theta dx$$

$$= [-11/2 x - 17/4 x^2/b - x^3/b^2]_0^b Fb^2 1/EJ + [x + 1/2 x^2/b]_0^b \theta$$

$$= (-11/2 b - 17/4 b - b) Fb^2 1/EJ + (b + 1/2 b) \theta = -49/4 Fb^3/EJ$$

$$L_{CD}^{xo} = \int_0^b (-11/2 + 11 x/b - 11/2 x^2/b^2) Fb^2 1/EJ dx = [-11/2 x + 11/2 x^2/b - 11/6 x^3/b^2]_0^b Fb^2 1/EJ$$

$$= (-11/2 b + 11/2 b - 11/6 b) Fb^2 1/EJ = -11/6 Fb^3/EJ$$

$$L_{DC}^{xo} = \int_0^b (-11/2 x^2/b^2) Fb^2 1/EJ dx = [-11/6 x^3/b^2]_0^b Fb^2 1/EJ$$

$$= (-11/6 b) Fb^2 1/EJ = -11/6 Fb^3/EJ$$

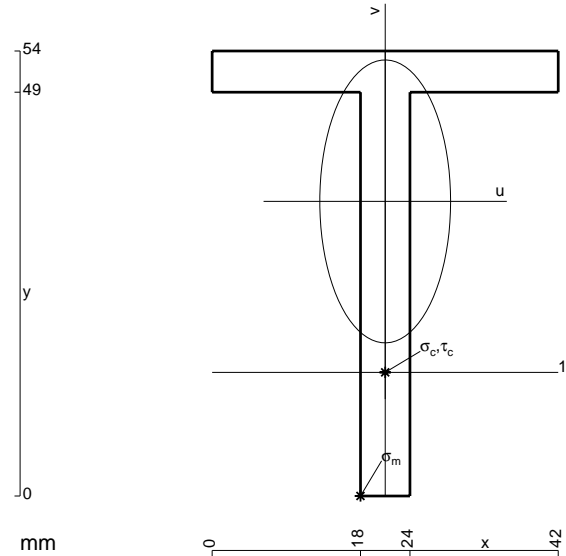

- A = 504. mm²
- J_u = 148565. mm⁴
- J_v = 31752. mm⁴
- y_g = 35.75 mm
- T_y = -1760. N
- M_x = 862400. Nmm
- x_m = 18. mm
- u_m = -3. mm
- v_m = -35.75 mm
- σ_m = -Mv/J_u = 207.5 N/mm²
- x_c = 21. mm
- y_c = 15. mm
- v_c = -20.75 mm
- σ_c = -Mv/J_u = 120.5 N/mm²
- τ_c = 5.02 N/mm²
- σ_q = √σ²+3τ² = 120.8 N/mm²
- S = 2543. mm³