

Schema di calcolo iperstatico

M_0 flessione da carichi assegnati

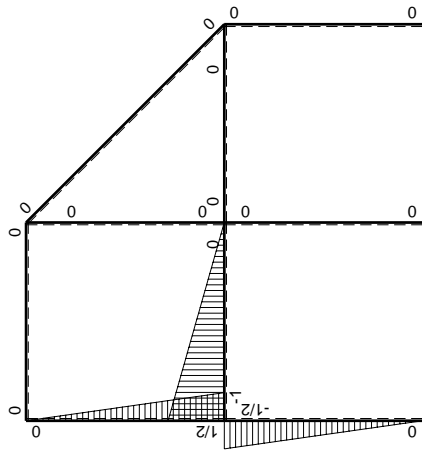

M_x flessione da iperstatica $X=1$

Quadro contributi PLV per iperstatica $X=W_{GD}$

→	$M_x(x)$	$M_o(x)$	θ	$M_x M_o$	$M_x \theta$	$M_x M_x$	$\int M_x(M_o/EJ+\theta)dx$	$\int X M_x M_x/EJdx$
AB b	0	-Fx	0	0	0	0	0+0	0
BA b	0	Fb-Fx	0	0	0	0	0	0
BC $\sqrt{2}b$	0	-Fb+ $\sqrt{2}/2Fx$	0	0	0	0	0	0
BD b	0	0	0	0	0	0	0+0	0
DB b	0	0	0	0	0	0	0	0
DC b	0	-2Fx	0	0	0	0	0+0	0
CD b	0	2Fb-2Fx	0	0	0	0	0	0
CE b	0	-Fb+Fx	0	0	0	0	0+0	0
EC b	0	Fx	0	0	0	0	0	0
FG b	-1/2x/b	-5/4Fx	-Fb/EJ	5/8Fx ² /b	1/2Fx/EJ	1/4x ² /b ²	(5/24+1/4)Fb ² /EJ	1/12Xb/EJ
GF b	1/2-1/2x/b	5/4Fb-5/4Fx	Fb/EJ	5/8Fb-5/4Fx+5/8Fx ² /b	1/2Fb/EJ-1/2Fx/EJ	1/4-1/2x/b+1/4x ² /b ²		
GD b	-1+x/b	-1/2Fx-1/2qx ²	0	1/2Fx-1/2qx ³ /b	0	1-2x/b+x ² /b ²	(1/8+0)Fb ² /EJ	1/3Xb/EJ
DG b	x/b	Fb-3/2Fx+1/2qx ²	0	Fx-3/2Fx ² /b+1/2qx ³ /b	0	x ² /b ²		
DH b	0	-Fb+Fx	0	0	0	0	0+0	0
HD b	0	Fx	0	0	0	0	0	0
GA b	1/2-1/2x/b	-1/4Fb-1/4Fx+1/2qx ²	0	-1/8Fb+3/8Fx ² /b-1/4qx ³ /b	0	1/4-1/2x/b+1/4x ² /b ²	(-1/16+0)Fb ² /EJ	1/12Xb/EJ
AG b	-1/2x/b	3/4Fx-1/2qx ²	0	-3/8Fx ² /b+1/4qx ³ /b	0	1/4x ² /b ²		
	totali						25/48Fb ² /EJ	1/2Xb/EJ
	iperstatica $X=W_{GD}$						-25/24Fb	

Sviluppi di calcolo iperstatica

$$L_{FG}^{xx} = \int_0^b (1/4 x^2/b^2) 1/EJ dx = [1/12 x^3/b^2]_0^b 1/EJ$$

$$= (1/12 b) 1/EJ = 1/12 b/EJ$$

$$L_{GF}^{xx} = \int_0^b (1/4 - 1/2 x/b + 1/4 x^2/b^2) 1/EJ dx = [1/4 x - 1/4 x^2/b + 1/12 x^3/b^2]_0^b 1/EJ$$

$$= (1/4 b - 1/4 b + 1/12 b) 1/EJ = 1/12 b/EJ$$

$$L_{GD}^{xx} = \int_0^b (1 - 2 x/b + x^2/b^2) 1/EJ dx = [x - x^2/b + 1/3 x^3/b^2]_0^b 1/EJ$$

$$= (b - b + 1/3 b) 1/EJ = 1/3 b/EJ$$

$$L_{DG}^{xx} = \int_0^b (x^2/b^2) 1/EJ dx = [1/3 x^3/b^2]_0^b 1/EJ$$

$$= (1/3 b) 1/EJ = 1/3 b/EJ$$

$$L_{GA}^{xx} = \int_0^b (1/4 - 1/2 x/b + 1/4 x^2/b^2) 1/EJ dx = [1/4 x - 1/4 x^2/b + 1/12 x^3/b^2]_0^b 1/EJ$$

$$= (1/4 b - 1/4 b + 1/12 b) 1/EJ = 1/12 b/EJ$$

$$L_{AG}^{xx} = \int_0^b (1/4 x^2/b^2) 1/EJ dx = [1/12 x^3/b^2]_0^b 1/EJ$$

$$= (1/12 b) 1/EJ = 1/12 b/EJ$$

$$L_{FG}^{xo} = \int_0^b (5/8 x^2/b^2) Fb 1/EJ dx + \int_0^b (1/2 x/b) \theta dx = [5/24 x^3/b^2]_0^b Fb 1/EJ + [1/4 x^2/b]_0^b \theta$$

$$= (5/24 b) Fb 1/EJ + (1/4 b) \theta = 11/24 Fb^2/EJ$$

$$L_{GF}^{xo} = \int_0^b (5/8 - 5/4 x/b + 5/8 x^2/b^2) Fb 1/EJ dx + \int_0^b (-1/2 + 1/2 x/b) \theta dx$$

$$= [5/8 x - 5/8 x^2/b + 5/24 x^3/b^2]_0^b Fb 1/EJ + [-1/2 x + 1/4 x^2/b]_0^b \theta$$

$$= (5/8 b - 5/8 b + 5/24 b) Fb 1/EJ + (-1/2 b + 1/4 b) \theta = 11/24 Fb^2/EJ$$

$$L_{GD}^{xo} = \int_0^b (1/2 x/b - 1/2 x^3/b^3) Fb 1/EJ dx = [1/4 x^2/b - 1/8 x^4/b^3]_0^b Fb 1/EJ$$

$$= (1/4 b - 1/8 b) Fb 1/EJ = 1/8 Fb^2/EJ$$

$$L_{DG}^{xo} = \int_0^b (x/b - 3/2 x^2/b^2 + 1/2 x^3/b^3) Fb 1/EJ dx = [1/2 x^2/b - 1/2 x^3/b^2 + 1/8 x^4/b^3]_0^b Fb 1/EJ$$

$$= (1/2 b - 1/2 b + 1/8 b) Fb 1/EJ = 1/8 Fb^2/EJ$$

$$L_{GA}^{xo} = \int_0^b (-1/8 + 3/8 x^2/b^2 - 1/4 x^3/b^3) Fb 1/EJ dx = [-1/8 x + 1/8 x^3/b^2 - 1/16 x^4/b^3]_0^b Fb 1/EJ$$

$$= (-1/8 b + 1/8 b - 1/16 b) Fb 1/EJ = -1/16 Fb^2/EJ$$

$$L_{AG}^{xo} = \int_0^b (-3/8 x^2/b^2 + 1/4 x^3/b^3) Fb 1/EJ dx = [-1/8 x^3/b^2 + 1/16 x^4/b^3]_0^b Fb 1/EJ$$

$$= (-1/8 b + 1/16 b) Fb 1/EJ = -1/16 Fb^2/EJ$$

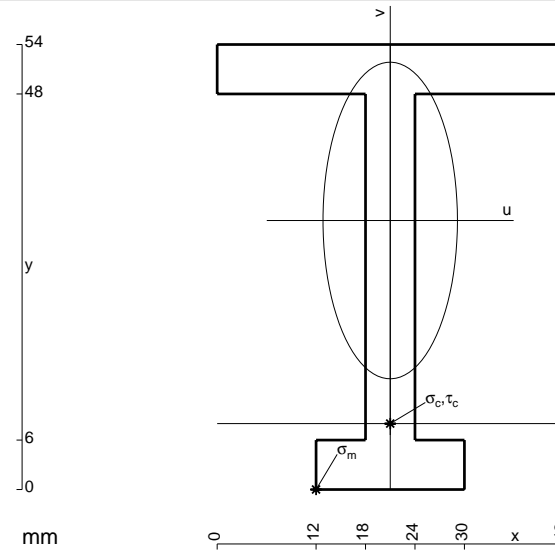

$$A = 612. \text{ mm}^2$$

$$J_u = 225968. \text{ mm}^4$$

$$J_v = 40716. \text{ mm}^4$$

$$y_g = 32.65 \text{ mm}$$

$$T_y = -2580. \text{ N}$$

$$M_x = -1444800. \text{ Nmm}$$

$$x_m = 12. \text{ mm}$$

$$u_m = -9. \text{ mm}$$

$$v_m = -32.65 \text{ mm}$$

$$\sigma_m = -Mv/J_u = -208.7 \text{ N/mm}^2$$

$$x_c = 21. \text{ mm}$$

$$y_c = 8. \text{ mm}$$

$$v_c = -24.65 \text{ mm}$$

$$\sigma_c = -Mv/J_u = -157.6 \text{ N/mm}^2$$

$$\tau_c = 6.679 \text{ N/mm}^2$$

$$\sigma_\rho = \sqrt{\sigma^2 + 3\tau^2} = 158. \text{ N/mm}^2$$

$$S = 3510. \text{ mm}^3$$

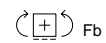
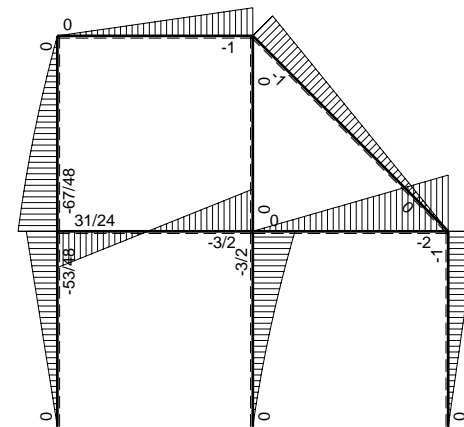
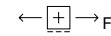
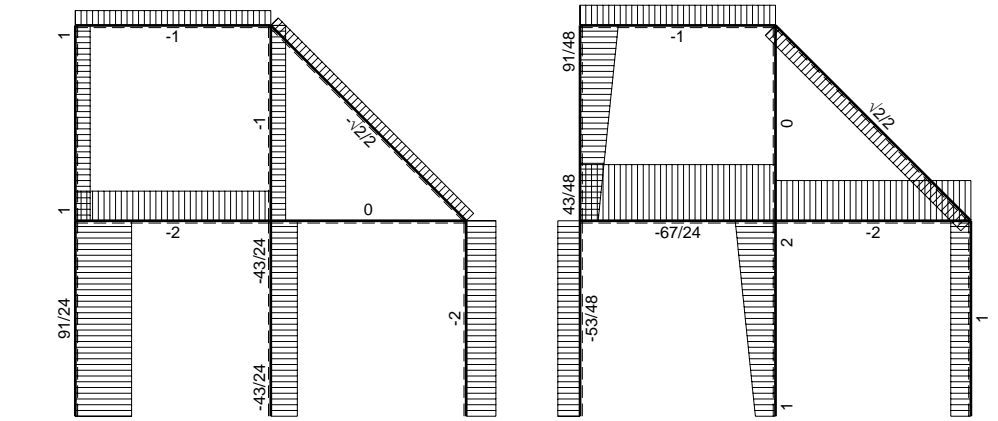
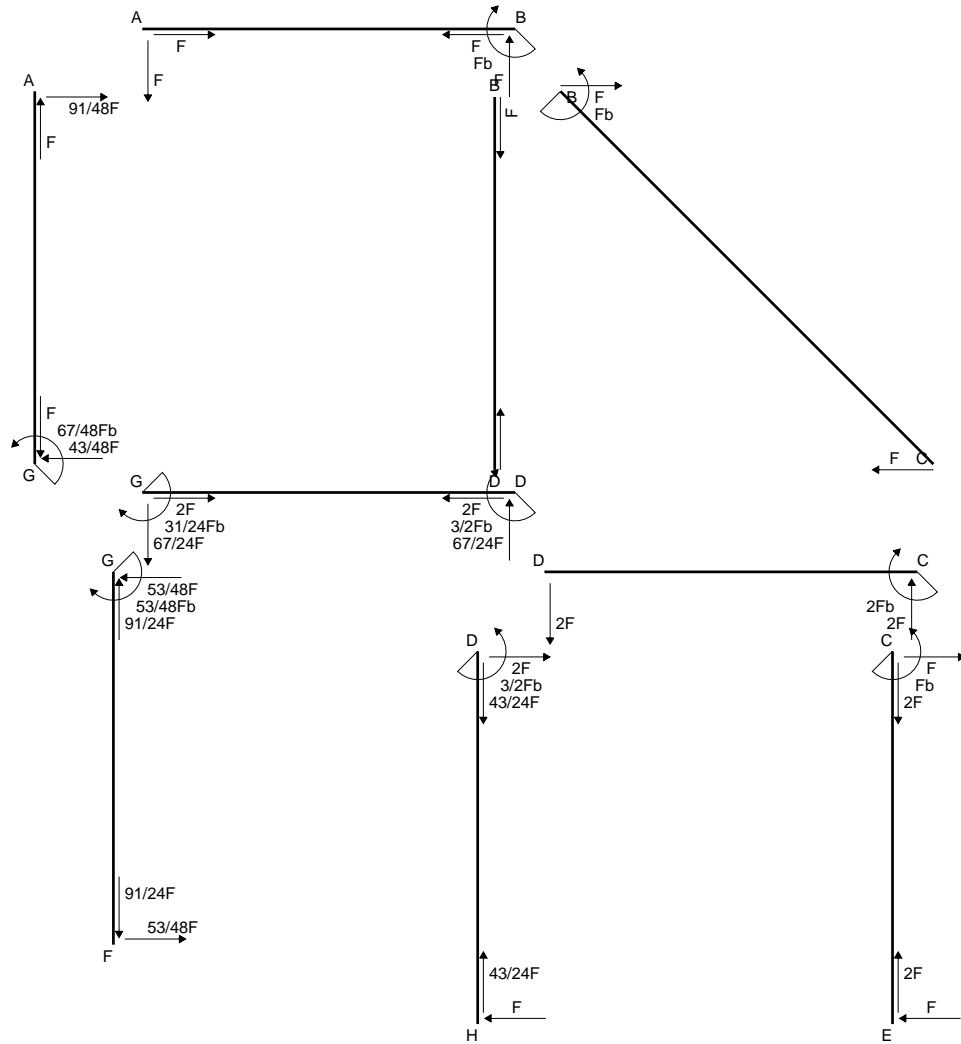

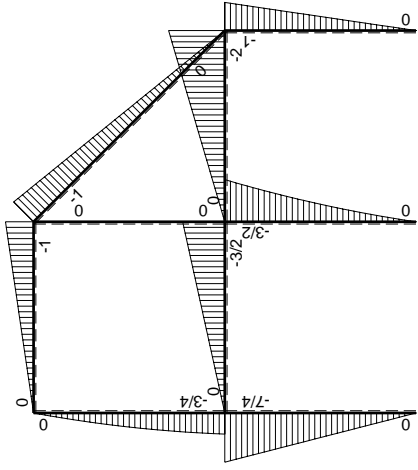
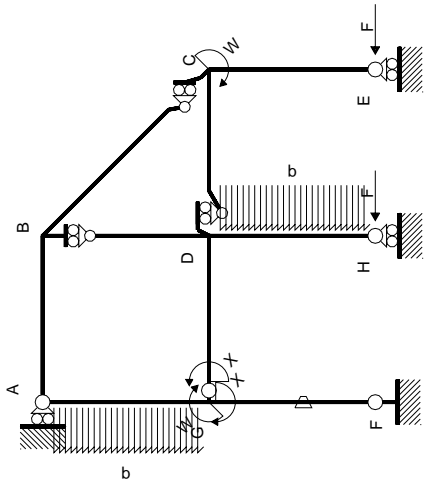

Schema di calcolo iperstatico

M_0 flessione da carichi assegnati

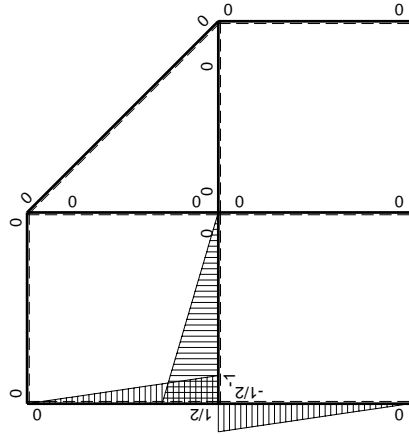

M_x flessione da iperstatica $X=1$

Quadro contributi PLV per iperstatica $X=W_{GD}$

→	$M_x(x)$	$M_o(x)$	θ	$M_x M_o$	$M_x \theta$	$M_x M_x$	$\int M_x(M_o/EJ+\theta)dx$	$\int X M_x M_x/EJ dx$	
AB b	0	-Fx	0	0	0	0	0+0	0	
BA b	0	Fb-Fx	0	0	0	0	0	0	
BC $\sqrt{2}b$	0	-Fb+ $\sqrt{2}/2Fx$	0	0	0	0	0	0	
BD b	0	0	0	0	0	0	0+0	0	
DB b	0	0	0	0	0	0	0	0	
DC b	0	-2Fx	0	0	0	0	0+0	0	
CD b	0	2Fb-2Fx	0	0	0	0	0	0	
CE b	0	-Fb+Fx	0	0	0	0	0+0	0	
EC b	0	Fx	0	0	0	0	0	0	
FG b	-1/2x/b	-7/4Fx	-Fb/EJ	7/8Fx ² /b	1/2Fx/EJ	1/4x ² /b ²	(7/24+1/4)Fb ² /EJ	1/12Xb/EJ	
GF b	1/2-1/2x/b	7/4Fb-7/4Fx	Fb/EJ	7/8Fb-7/4Fx+7/8Fx ² /b	1/2Fb/EJ-1/2Fx/EJ	1/4-1/2x/b+1/4x ² /b ²			
GD b	-1+x/b	-3/2Fx	0	3/2Fx-3/2Fx ² /b	0	1-2x/b+x ² /b ²	(1/4+0)Fb ² /EJ	1/3Xb/EJ	
DG b	x/b	3/2Fb-3/2Fx	0	3/2Fx-3/2Fx ² /b	0	x ² /b ²			
DH b	0	-3/2Fb+2Fx-1/2qx ²	0	0	0	0	0+0	0	
HD b	0	Fx+1/2qx ²	0	0	0	0			
GA b	1/2-1/2x/b	-3/4Fb+1/4Fx+1/2qx ²	0	-3/8Fb+1/2Fx+1/8Fx ² /b-1/4qx ³ /b	0	1/4-1/2x/b+1/4x ² /b ²	(-7/48+0)Fb ² /EJ	1/12Xb/EJ	
AG b	-1/2x/b	5/4Fx-1/2qx ²	0	-5/8Fx ² /b+1/4qx ³ /b	0	1/4x ² /b ²			
	totali							31/48Fb ² /EJ	1/2Xb/EJ
	iperstatica $X=W_{GD}$							-31/24Fb	

Sviluppi di calcolo iperstatica

$$L_{FG}^{xx} = \int_0^b (1/4 x^2/b^2) 1/EJ dx = [1/12 x^3/b^2]_0^b 1/EJ$$

$$= (1/12 b) 1/EJ = 1/12 b/EJ$$

$$L_{GF}^{xx} = \int_0^b (1/4 - 1/2 x/b + 1/4 x^2/b^2) 1/EJ dx = [1/4 x - 1/4 x^2/b + 1/12 x^3/b^2]_0^b 1/EJ$$

$$= (1/4 b - 1/4 b + 1/12 b) 1/EJ = 1/12 b/EJ$$

$$L_{GD}^{xx} = \int_0^b (1 - 2 x/b + x^2/b^2) 1/EJ dx = [x - x^2/b + 1/3 x^3/b^2]_0^b 1/EJ$$

$$= (b - b + 1/3 b) 1/EJ = 1/3 b/EJ$$

$$L_{DG}^{xx} = \int_0^b (x^2/b^2) 1/EJ dx = [1/3 x^3/b^2]_0^b 1/EJ$$

$$= (1/3 b) 1/EJ = 1/3 b/EJ$$

$$L_{GA}^{xx} = \int_0^b (1/4 - 1/2 x/b + 1/4 x^2/b^2) 1/EJ dx = [1/4 x - 1/4 x^2/b + 1/12 x^3/b^2]_0^b 1/EJ$$

$$= (1/4 b - 1/4 b + 1/12 b) 1/EJ = 1/12 b/EJ$$

$$L_{AG}^{xx} = \int_0^b (1/4 x^2/b^2) 1/EJ dx = [1/12 x^3/b^2]_0^b 1/EJ$$

$$= (1/12 b) 1/EJ = 1/12 b/EJ$$

$$L_{FG}^{xo} = \int_0^b (7/8 x^2/b^2) Fb 1/EJ dx + \int_0^b (1/2 x/b) \theta dx = [7/24 x^3/b^2]_0^b Fb 1/EJ + [1/4 x^2/b]_0^b \theta$$

$$= (7/24 b) Fb 1/EJ + (1/4 b) \theta = 13/24 Fb^2/EJ$$

$$L_{GF}^{xo} = \int_0^b (7/8 - 7/4 x/b + 7/8 x^2/b^2) Fb 1/EJ dx + \int_0^b (-1/2 + 1/2 x/b) \theta dx$$

$$= [7/8 x - 7/8 x^2/b + 7/24 x^3/b^2]_0^b Fb 1/EJ + [-1/2 x + 1/4 x^2/b]_0^b \theta$$

$$= (7/8 b - 7/8 b + 7/24 b) Fb 1/EJ + (-1/2 b + 1/4 b) \theta = 13/24 Fb^2/EJ$$

$$L_{GD}^{xo} = \int_0^b (3/2 x/b - 3/2 x^2/b^2) Fb 1/EJ dx = [3/4 x^2/b - 1/2 x^3/b^2]_0^b Fb 1/EJ$$

$$= (3/4 b - 1/2 b) Fb 1/EJ = 1/4 Fb^2/EJ$$

$$L_{DG}^{xo} = \int_0^b (3/2 x/b - 3/2 x^2/b^2) Fb 1/EJ dx = [3/4 x^2/b - 1/2 x^3/b^2]_0^b Fb 1/EJ$$

$$= (3/4 b - 1/2 b) Fb 1/EJ = 1/4 Fb^2/EJ$$

$$L_{GA}^{xo} = \int_0^b (-3/8 + 1/2 x/b + 1/8 x^2/b^2 - 1/4 x^3/b^3) Fb 1/EJ dx$$

$$= [-3/8 x + 1/4 x^2/b + 1/24 x^3/b^2 - 1/16 x^4/b^3]_0^b Fb 1/EJ$$

$$= (-3/8 b + 1/4 b + 1/24 b - 1/16 b) Fb 1/EJ = -7/48 Fb^2/EJ$$

$$L_{AG}^{xo} = \int_0^b (-5/8 x^2/b^2 + 1/4 x^3/b^3) Fb 1/EJ dx = [-5/24 x^3/b^2 + 1/16 x^4/b^3]_0^b Fb 1/EJ$$

$$= (-5/24 b + 1/16 b) Fb 1/EJ = -7/48 Fb^2/EJ$$

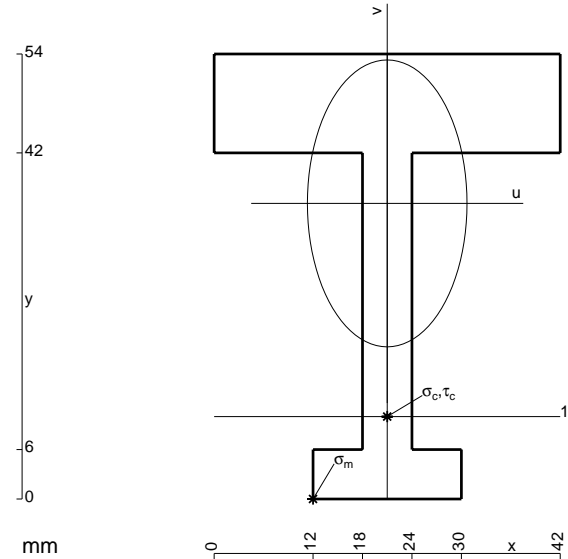

$$A = 828. \text{ mm}^2$$

$$J_u = 250978. \text{ mm}^4$$

$$J_v = 77652. \text{ mm}^4$$

$$y_g = 35.87 \text{ mm}$$

$$T_y = -2520. \text{ N}$$

$$M_x = -1537200. \text{ Nmm}$$

$$x_m = 12. \text{ mm}$$

$$u_m = -9. \text{ mm}$$

$$v_m = -35.87 \text{ mm}$$

$$\sigma_m = -Mv/J_u = -219.7 \text{ N/mm}^2$$

$$x_c = 21. \text{ mm}$$

$$y_c = 10. \text{ mm}$$

$$v_c = -25.87 \text{ mm}$$

$$\sigma_c = -Mv/J_u = -158.4 \text{ N/mm}^2$$

$$\tau_c = 7.06 \text{ N/mm}^2$$

$$\sigma_q = \sqrt{\sigma^2 + 3\tau^2} = 158.9 \text{ N/mm}^2$$

$$S = 4219. \text{ mm}^3$$

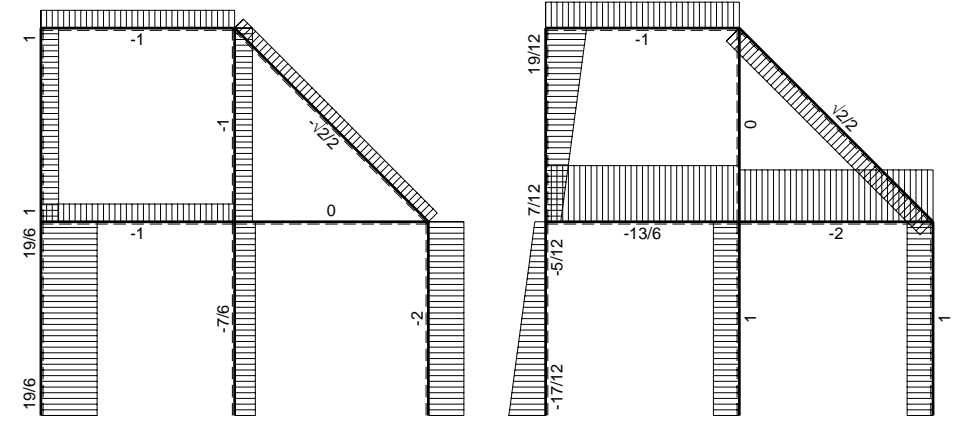
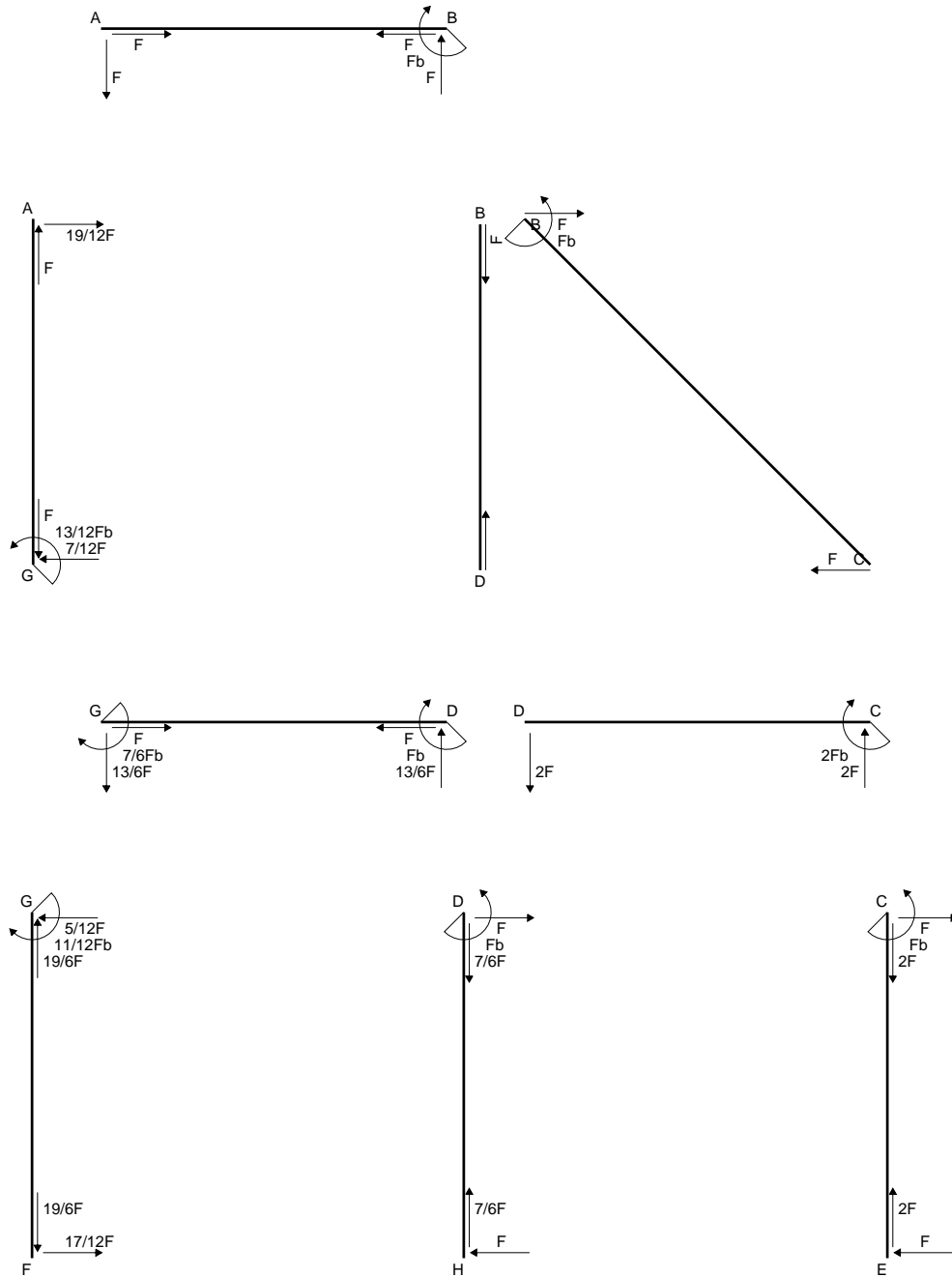

← ⊕ → F

↑ ⊕ ↓ F

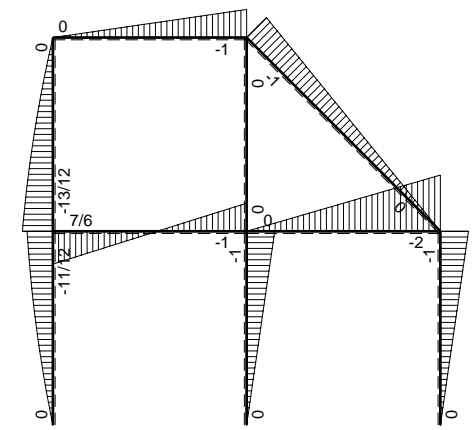

⊕ ⊖ F_b

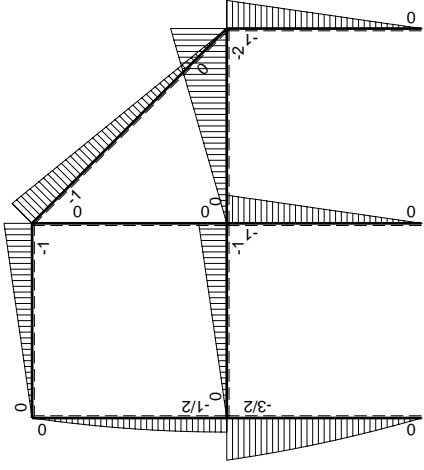
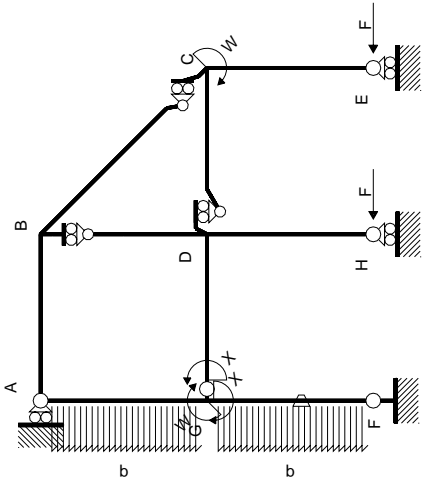

Schema di calcolo iperstatico

M_0 flessione da carichi assegnati

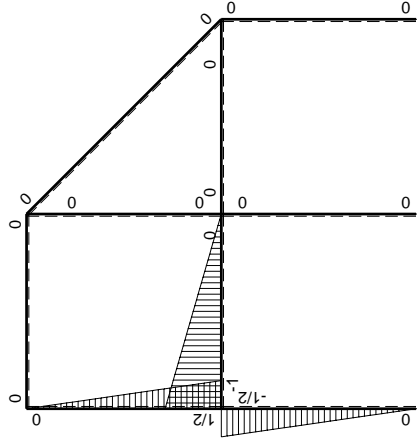

M_x flessione da iperstatica X=1

Quadro contributi PLV per iperstatica $X=W_{GD}$

→	$M_x(x)$	$M_o(x)$	θ	$M_x M_o$	$M_x \theta$	$M_x M_x$	$\int M_x(M_o/EJ+\theta)dx$	$\int X M_x M_x/EJ dx$	
AB b	0	-Fx	0	0	0	0	0+0	0	
BA b	0	Fb-Fx	0	0	0	0	0	0	
BC $\sqrt{2}b$	0	-Fb+ $\sqrt{2}/2Fx$	0	0	0	0	0	0	
BD b	0	0	0	0	0	0	0+0	0	
DB b	0	0	0	0	0	0	0	0	
DC b	0	-2Fx	0	0	0	0	0+0	0	
CD b	0	2Fb-2Fx	0	0	0	0	0	0	
CE b	0	-Fb+Fx	0	0	0	0	0+0	0	
EC b	0	Fx	0	0	0	0	0	0	
FG b	-1/2x/b	-2Fx+1/2qx ²	-Fb/EJ	$Fx^2/b-1/4qx^3/b$	1/2Fx/EJ	$1/4x^2/b^2$	$(13/48+1/4)Fb^2/EJ$	1/12Xb/EJ	
GF b	1/2-1/2x/b	3/2Fb-Fx-1/2qx ²	Fb/EJ	$3/4Fb-5/4Fx+1/4Fx^2/b+1/4qx^3/b$	1/2Fb/EJ-1/2Fx/EJ	$1/4-1/2x/b+1/4x^2/b^2$			
GD b	-1+x/b	-Fx	0	$Fx-Fx^2/b$	0	$1-2x/b+x^2/b^2$	$(1/6+0)Fb^2/EJ$	1/3Xb/EJ	
DG b	x/b	Fb-Fx	0	$Fx-Fx^2/b$	0	x^2/b^2			
DH b	0	-Fb+Fx	0	0	0	0	0+0	0	
HD b	0	Fx	0	0	0	0			
GA b	1/2-1/2x/b	-1/2Fb+1/2qx ²	0	$-1/4Fb+1/4Fx+1/4Fx^2/b-1/4qx^3/b$	0	$1/4-1/2x/b+1/4x^2/b^2$	$(-5/48+0)Fb^2/EJ$	1/12Xb/EJ	
AG b	-1/2x/b	Fx-1/2qx ²	0	$-1/2Fx^2/b+1/4qx^3/b$	0	$1/4x^2/b^2$			
	totali							7/12Fb ² /EJ	1/2Xb/EJ
	iperstatica $X=W_{GD}$							-7/6Fb	

Sviluppi di calcolo iperstatica

$$L_{FG}^{xx} = \int_0^b (1/4 x^2/b^2) 1/EJ dx = [1/12 x^3/b^2]_0^b 1/EJ$$

$$= (1/12 b) 1/EJ = 1/12 b/EJ$$

$$L_{GF}^{xx} = \int_0^b (1/4 - 1/2 x/b + 1/4 x^2/b^2) 1/EJ dx = [1/4 x - 1/4 x^2/b + 1/12 x^3/b^2]_0^b 1/EJ$$

$$= (1/4 b - 1/4 b + 1/12 b) 1/EJ = 1/12 b/EJ$$

$$L_{GD}^{xx} = \int_0^b (1 - 2 x/b + x^2/b^2) 1/EJ dx = [x - x^2/b + 1/3 x^3/b^2]_0^b 1/EJ$$

$$= (b - b + 1/3 b) 1/EJ = 1/3 b/EJ$$

$$L_{DG}^{xx} = \int_0^b (x^2/b^2) 1/EJ dx = [1/3 x^3/b^2]_0^b 1/EJ$$

$$= (1/3 b) 1/EJ = 1/3 b/EJ$$

$$L_{GA}^{xx} = \int_0^b (1/4 - 1/2 x/b + 1/4 x^2/b^2) 1/EJ dx = [1/4 x - 1/4 x^2/b + 1/12 x^3/b^2]_0^b 1/EJ$$

$$= (1/4 b - 1/4 b + 1/12 b) 1/EJ = 1/12 b/EJ$$

$$L_{AG}^{xx} = \int_0^b (1/4 x^2/b^2) 1/EJ dx = [1/12 x^3/b^2]_0^b 1/EJ$$

$$= (1/12 b) 1/EJ = 1/12 b/EJ$$

$$L_{FG}^{xo} = \int_0^b (x^2/b^2 - 1/4 x^3/b^3) Fb 1/EJ dx + \int_0^b (1/2 x/b) \theta dx$$

$$= [1/3 x^3/b^2 - 1/16 x^4/b^3]_0^b Fb 1/EJ + [1/4 x^2/b]_0^b \theta$$

$$= (1/3 b - 1/16 b) Fb 1/EJ + (1/4 b) \theta = 25/48 Fb^2/EJ$$

$$L_{GF}^{xo} = \int_0^b (3/4 - 5/4 x/b + 1/4 x^2/b^2 + 1/4 x^3/b^3) Fb 1/EJ dx + \int_0^b (-1/2 + 1/2 x/b) \theta dx$$

$$= [3/4 x - 5/8 x^2/b + 1/12 x^3/b^2 + 1/16 x^4/b^3]_0^b Fb 1/EJ + [-1/2 x + 1/4 x^2/b]_0^b \theta$$

$$= (3/4 b - 5/8 b + 1/12 b + 1/16 b) Fb 1/EJ + (-1/2 b + 1/4 b) \theta = 25/48 Fb^2/EJ$$

$$L_{GD}^{xo} = \int_0^b (x/b - x^2/b^2) Fb 1/EJ dx = [1/2 x^2/b - 1/3 x^3/b^2]_0^b Fb 1/EJ$$

$$= (1/2 b - 1/3 b) Fb 1/EJ = 1/6 Fb^2/EJ$$

$$L_{DG}^{xo} = \int_0^b (x/b - x^2/b^2) Fb 1/EJ dx = [1/2 x^2/b - 1/3 x^3/b^2]_0^b Fb 1/EJ$$

$$= (1/2 b - 1/3 b) Fb 1/EJ = 1/6 Fb^2/EJ$$

$$L_{GA}^{xo} = \int_0^b (-1/4 + 1/4 x/b + 1/4 x^2/b^2 - 1/4 x^3/b^3) Fb 1/EJ dx$$

$$= [-1/4 x + 1/8 x^2/b + 1/12 x^3/b^2 - 1/16 x^4/b^3]_0^b Fb 1/EJ$$

$$= (-1/4 b + 1/8 b + 1/12 b - 1/16 b) Fb 1/EJ = -5/48 Fb^2/EJ$$

$$L_{AG}^{xo} = \int_0^b (-1/2 x^2/b^2 + 1/4 x^3/b^3) Fb 1/EJ dx = [-1/6 x^3/b^2 + 1/16 x^4/b^3]_0^b Fb 1/EJ$$

$$= (-1/6 b + 1/16 b) Fb 1/EJ = -5/48 Fb^2/EJ$$

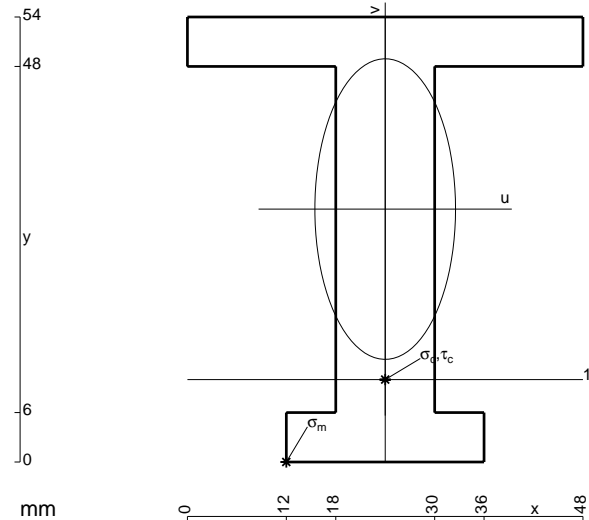

- A = 936. mm²
- J_u = 311455. mm⁴
- J_v = 68256. mm⁴
- y_g = 30.69 mm
- T_y = -3520. N
- M_x = -2323200. Nmm
- x_m = 12. mm
- u_m = -12. mm
- v_m = -30.69 mm
- σ_m = -Mv/J_u = -228.9 N/mm²
- x_c = 24. mm
- y_c = 10. mm
- v_c = -20.69 mm
- σ_c = -Mv/J_u = -154.3 N/mm²
- τ_c = 4.782 N/mm²
- σ_q = √σ²+3τ² = 154.6 N/mm²
- S = 5077. mm³

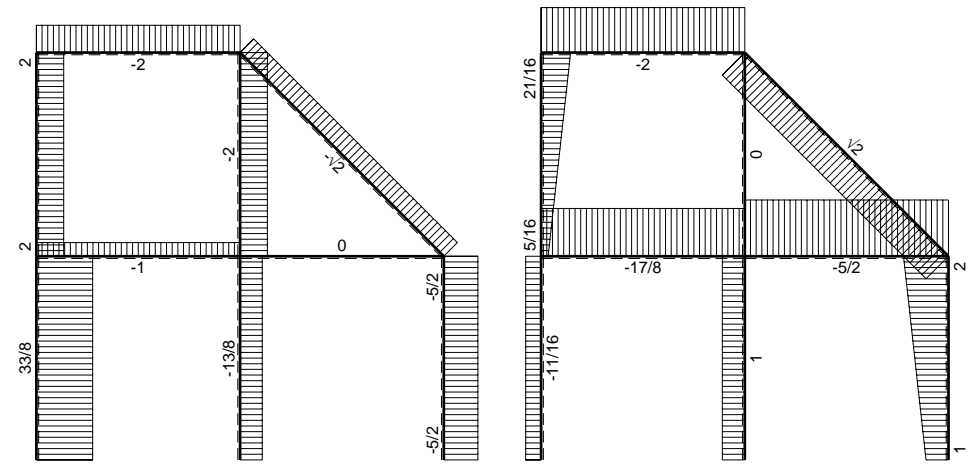
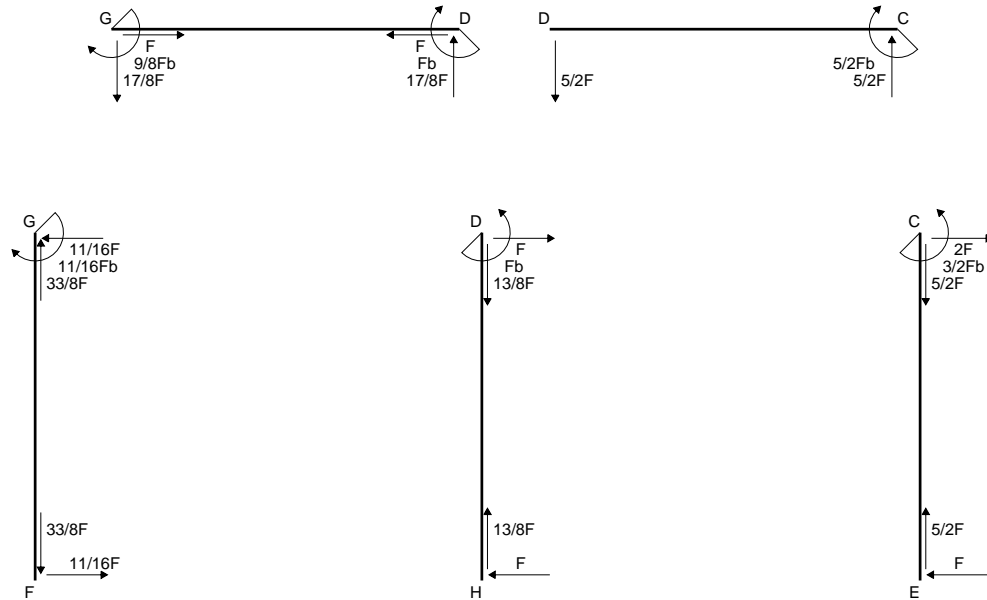
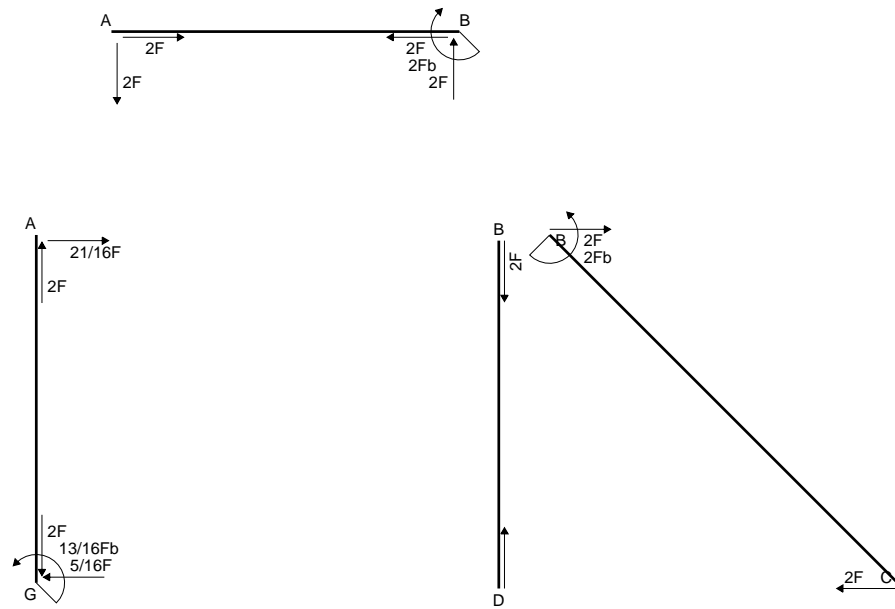

← ⊕ → F

↑ ⊕ ↓ F

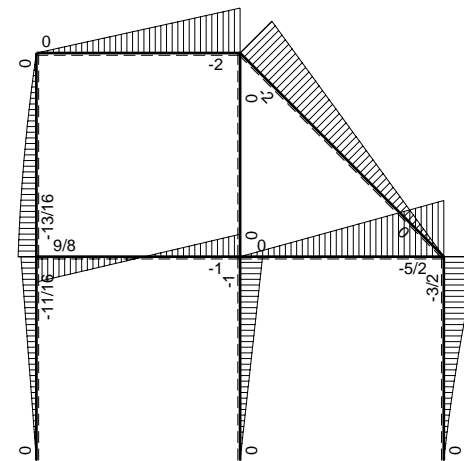

⊕ ⊕ Fb

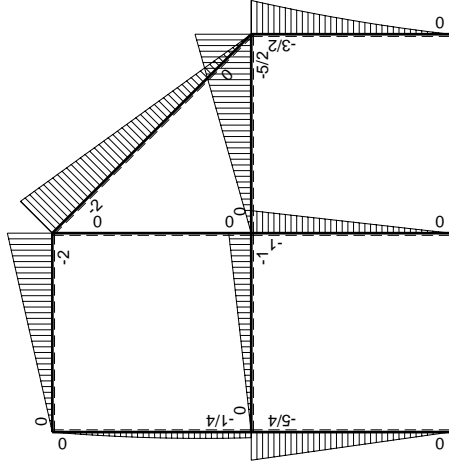
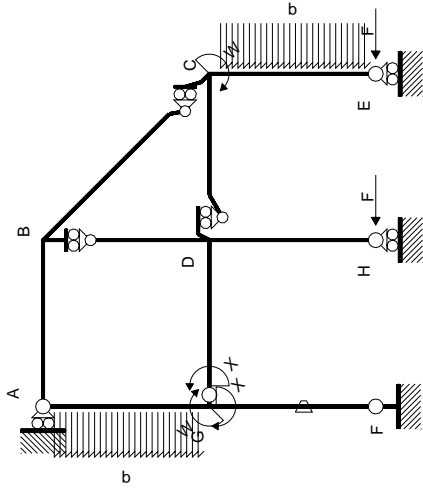

Schema di calcolo iperstatico

M_0 flessione da carichi assegnati

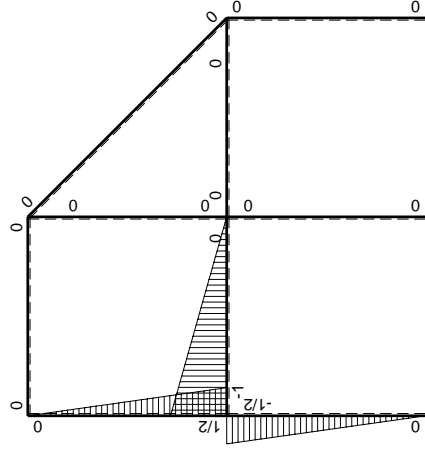

M_x flessione da iperstatica $X=1$

Quadro contributi PLV per iperstatica $X=W_{GD}$

→	$M_x(x)$	$M_o(x)$	θ	$M_x M_o$	$M_x \theta$	$M_x M_x$	$\int M_x(M_o/EJ+\theta)dx$	$\int X M_x M_x/EJdx$
AB b	0	-2Fx	0	0	0	0	0+0	0
BA b	0	2Fb-2Fx	0	0	0	0	0	0
BC $\sqrt{2}b$	0	-2Fb+ $\sqrt{2}Fx$	0	0	0	0	0	0
BD b	0	0	0	0	0	0	0+0	0
DB b	0	0	0	0	0	0	0	0
DC b	0	-5/2Fx	0	0	0	0	0+0	0
CD b	0	5/2Fb-5/2Fx	0	0	0	0	0	0
CE b	0	-3/2Fb+2Fx-1/2qx ²	0	0	0	0	0+0	0
EC b	0	Fx+1/2qx ²	0	0	0	0	0	0
FG b	-1/2x/b	-5/4Fx	-Fb/EJ	5/8Fx ² /b	1/2Fx/EJ	1/4x ² /b ²	(5/24+1/4)Fb ² /EJ	1/12Xb/EJ
GF b	1/2-1/2x/b	5/4Fb-5/4Fx	Fb/EJ	5/8Fb-5/4Fx+5/8Fx ² /b	1/2Fb/EJ-1/2Fx/EJ	1/4-1/2x/b+1/4x ² /b ²		
GD b	-1+x/b	-Fx	0	Fx-Fx ² /b	0	1-2x/b+x ² /b ²	(1/6+0)Fb ² /EJ	1/3Xb/EJ
DG b	x/b	Fb-Fx	0	Fx-Fx ² /b	0	x ² /b ²		
DH b	0	-Fb+Fx	0	0	0	0	0+0	0
HD b	0	Fx	0	0	0	0	0	0
GA b	1/2-1/2x/b	-1/4Fb-1/4Fx+1/2qx ²	0	-1/8Fb+3/8Fx ² /b-1/4qx ³ /b	0	1/4-1/2x/b+1/4x ² /b ²	(-1/16+0)Fb ² /EJ	1/12Xb/EJ
AG b	-1/2x/b	3/4Fx-1/2qx ²	0	-3/8Fx ² /b+1/4qx ³ /b	0	1/4x ² /b ²		
	totali						9/16Fb ² /EJ	1/2Xb/EJ
	iperstatica $X=W_{GD}$						-9/8Fb	

Sviluppi di calcolo iperstatica

$$L_{FG}^{xx} = \int_0^b (1/4 x^2/b^2) 1/EJ dx = [1/12 x^3/b^2]_0^b 1/EJ$$

$$= (1/12 b) 1/EJ = 1/12 b/EJ$$

$$L_{GF}^{xx} = \int_0^b (1/4 - 1/2 x/b + 1/4 x^2/b^2) 1/EJ dx = [1/4 x - 1/4 x^2/b + 1/12 x^3/b^2]_0^b 1/EJ$$

$$= (1/4 b - 1/4 b + 1/12 b) 1/EJ = 1/12 b/EJ$$

$$L_{GD}^{xx} = \int_0^b (1 - 2 x/b + x^2/b^2) 1/EJ dx = [x - x^2/b + 1/3 x^3/b^2]_0^b 1/EJ$$

$$= (b - b + 1/3 b) 1/EJ = 1/3 b/EJ$$

$$L_{DG}^{xx} = \int_0^b (x^2/b^2) 1/EJ dx = [1/3 x^3/b^2]_0^b 1/EJ$$

$$= (1/3 b) 1/EJ = 1/3 b/EJ$$

$$L_{GA}^{xx} = \int_0^b (1/4 - 1/2 x/b + 1/4 x^2/b^2) 1/EJ dx = [1/4 x - 1/4 x^2/b + 1/12 x^3/b^2]_0^b 1/EJ$$

$$= (1/4 b - 1/4 b + 1/12 b) 1/EJ = 1/12 b/EJ$$

$$L_{AG}^{xx} = \int_0^b (1/4 x^2/b^2) 1/EJ dx = [1/12 x^3/b^2]_0^b 1/EJ$$

$$= (1/12 b) 1/EJ = 1/12 b/EJ$$

$$L_{FG}^{xo} = \int_0^b (5/8 x^2/b^2) Fb 1/EJ dx + \int_0^b (1/2 x/b) \theta dx = [5/24 x^3/b^2]_0^b Fb 1/EJ + [1/4 x^2/b]_0^b \theta$$

$$= (5/24 b) Fb 1/EJ + (1/4 b) \theta = 11/24 Fb^2/EJ$$

$$L_{GF}^{xo} = \int_0^b (5/8 - 5/4 x/b + 5/8 x^2/b^2) Fb 1/EJ dx + \int_0^b (-1/2 + 1/2 x/b) \theta dx$$

$$= [5/8 x - 5/8 x^2/b + 5/24 x^3/b^2]_0^b Fb 1/EJ + [-1/2 x + 1/4 x^2/b]_0^b \theta$$

$$= (5/8 b - 5/8 b + 5/24 b) Fb 1/EJ + (-1/2 b + 1/4 b) \theta = 11/24 Fb^2/EJ$$

$$L_{GD}^{xo} = \int_0^b (x/b - x^2/b^2) Fb 1/EJ dx = [1/2 x^2/b - 1/3 x^3/b^2]_0^b Fb 1/EJ$$

$$= (1/2 b - 1/3 b) Fb 1/EJ = 1/6 Fb^2/EJ$$

$$L_{DG}^{xo} = \int_0^b (x/b - x^2/b^2) Fb 1/EJ dx = [1/2 x^2/b - 1/3 x^3/b^2]_0^b Fb 1/EJ$$

$$= (1/2 b - 1/3 b) Fb 1/EJ = 1/6 Fb^2/EJ$$

$$L_{GA}^{xo} = \int_0^b (-1/8 + 3/8 x^2/b^2 - 1/4 x^3/b^3) Fb 1/EJ dx = [-1/8 x + 1/8 x^3/b^2 - 1/16 x^4/b^3]_0^b Fb 1/EJ$$

$$= (-1/8 b + 1/8 b - 1/16 b) Fb 1/EJ = -1/16 Fb^2/EJ$$

$$L_{AG}^{xo} = \int_0^b (-3/8 x^2/b^2 + 1/4 x^3/b^3) Fb 1/EJ dx = [-1/8 x^3/b^2 + 1/16 x^4/b^3]_0^b Fb 1/EJ$$

$$= (-1/8 b + 1/16 b) Fb 1/EJ = -1/16 Fb^2/EJ$$

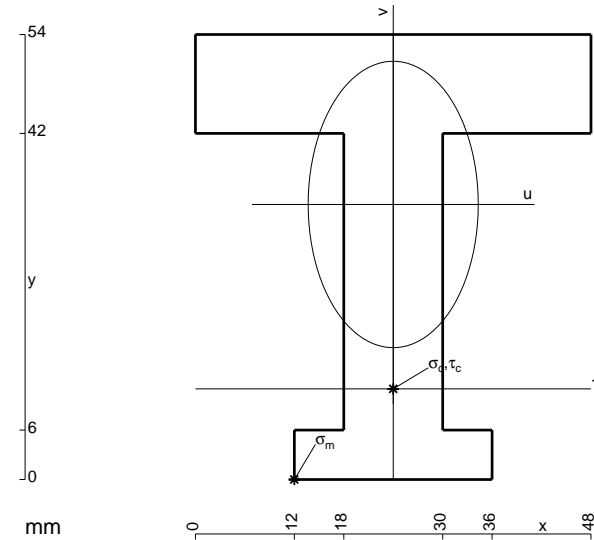

$$A = 1152. \text{ mm}^2$$

$$J_u = 348030. \text{ mm}^4$$

$$J_v = 122688. \text{ mm}^4$$

$$y_g = 33.38 \text{ mm}$$

$$T_y = -3500. \text{ N}$$

$$M_x = -2485000. \text{ Nmm}$$

$$x_m = 12. \text{ mm}$$

$$u_m = -12. \text{ mm}$$

$$v_m = -33.38 \text{ mm}$$

$$\sigma_m = -Mv/J_u = -238.3 \text{ N/mm}^2$$

$$x_c = 24. \text{ mm}$$

$$y_c = 11. \text{ mm}$$

$$v_c = -22.38 \text{ mm}$$

$$\sigma_c = -Mv/J_u = -159.8 \text{ N/mm}^2$$

$$\tau_c = 4.916 \text{ N/mm}^2$$

$$\sigma_\rho = \sqrt{\sigma^2 + 3\tau^2} = 160. \text{ N/mm}^2$$

$$S = 5867. \text{ mm}^3$$

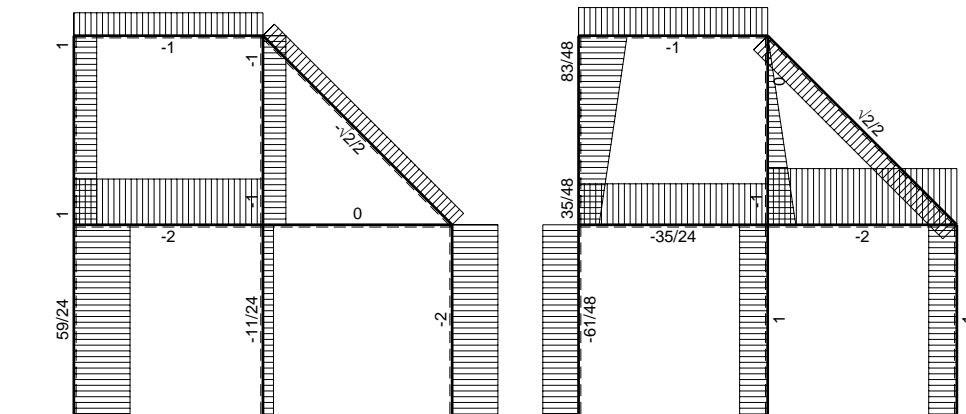
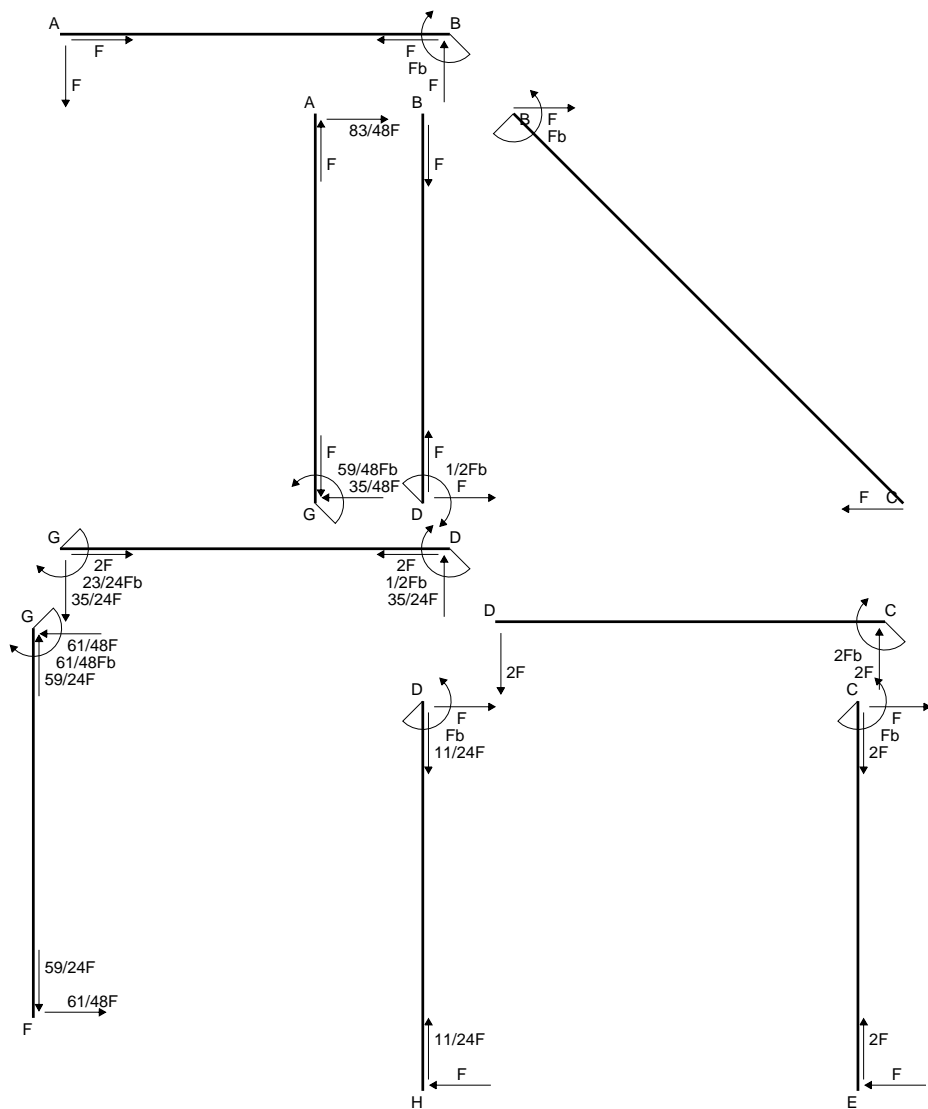

← ⊕ → F

↑ ⊕ ↓ F

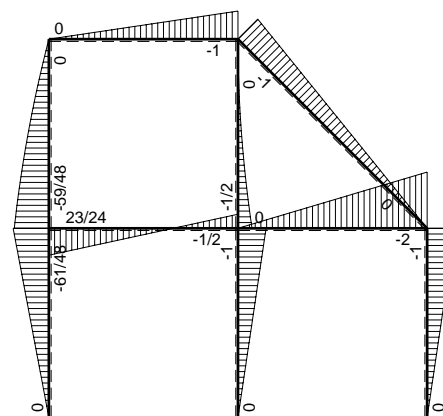

⊕ F_b

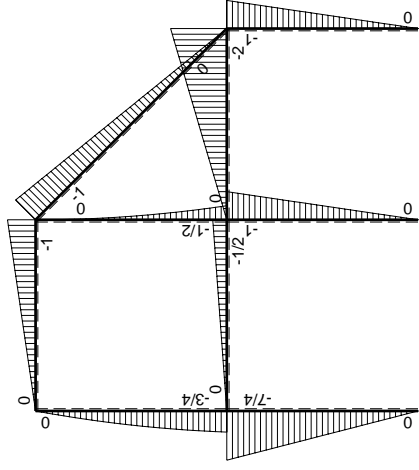
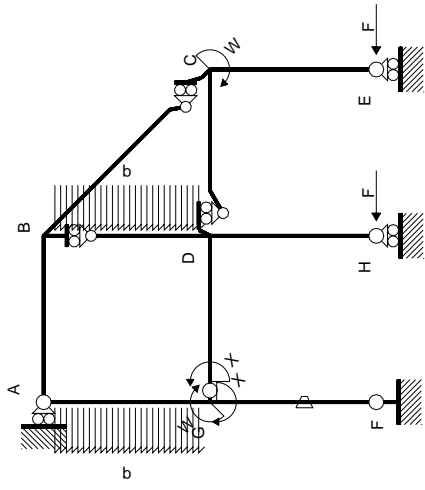

Schema di calcolo iperstatico

M_0 flessione da carichi assegnati

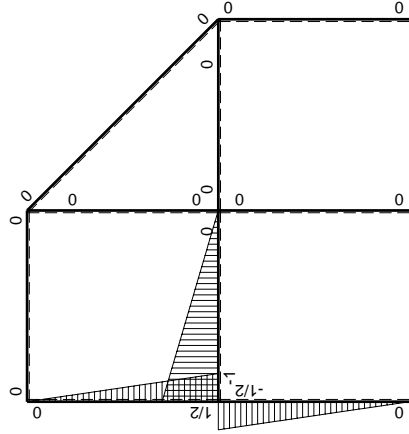

M_1 flessione da iperstatica $X=1$

Quadro contributi PLV per iperstatica $X=W_{GD}$

→	$M_x(x)$	$M_o(x)$	θ	$M_x M_o$	$M_x \theta$	$M_x M_x$	$\int M_x(M_o/EJ+\theta)dx$	$\int X M_x M_x/EJ dx$	
AB b	0	-Fx	0	0	0	0	0+0	0	
BA b	0	Fb-Fx	0	0	0	0	0	0	
BC $\sqrt{2}b$	0	-Fb+ $\sqrt{2}/2Fx$	0	0	0	0	0	0	
BD b	0	-1/2qx ²	0	0	0	0	0+0	0	
DB b	0	1/2Fb-Fx+1/2qx ²	0	0	0	0	0	0	
DC b	0	-2Fx	0	0	0	0	0+0	0	
CD b	0	2Fb-2Fx	0	0	0	0	0	0	
CE b	0	-Fb+Fx	0	0	0	0	0+0	0	
EC b	0	Fx	0	0	0	0	0	0	
FG b	-1/2x/b	-7/4Fx	-Fb/EJ	7/8Fx ² /b	1/2Fx/EJ	1/4x ² /b ²	(7/24+1/4)Fb ² /EJ	1/12Xb/EJ	
GF b	1/2-1/2x/b	7/4Fb-7/4Fx	Fb/EJ	7/8Fb-7/4Fx+7/8Fx ² /b	1/2Fb/EJ-1/2Fx/EJ	1/4-1/2x/b+1/4x ² /b ²			
GD b	-1+x/b	-1/2Fx	0	1/2Fx-1/2Fx ² /b	0	1-2x/b+x ² /b ²	(1/12+0)Fb ² /EJ	1/3Xb/EJ	
DG b	x/b	1/2Fb-1/2Fx	0	1/2Fx-1/2Fx ² /b	0	x ² /b ²			
DH b	0	-Fb+Fx	0	0	0	0	0+0	0	
HD b	0	Fx	0	0	0	0	0	0	
GA b	1/2-1/2x/b	-3/4Fb+1/4Fx+1/2qx ²	0	-3/8Fb+1/2Fx+1/8Fx ² /b-1/4qx ³ /b	0	1/4-1/2x/b+1/4x ² /b ²	(-7/48+0)Fb ² /EJ	1/12Xb/EJ	
AG b	-1/2x/b	5/4Fx-1/2qx ²	0	-5/8Fx ² /b+1/4qx ³ /b	0	1/4x ² /b ²			
	totali							23/48Fb ² /EJ	1/2Xb/EJ
	iperstatica $X=W_{GD}$							-23/24Fb	

Sviluppi di calcolo iperstatica

$$L_{FG}^{xx} = \int_0^b (1/4 x^2/b^2) 1/EJ dx = [1/12 x^3/b^2]_0^b 1/EJ$$

$$= (1/12 b) 1/EJ = 1/12 b/EJ$$

$$L_{GF}^{xx} = \int_0^b (1/4 - 1/2 x/b + 1/4 x^2/b^2) 1/EJ dx = [1/4 x - 1/4 x^2/b + 1/12 x^3/b^2]_0^b 1/EJ$$

$$= (1/4 b - 1/4 b + 1/12 b) 1/EJ = 1/12 b/EJ$$

$$L_{GD}^{xx} = \int_0^b (1 - 2 x/b + x^2/b^2) 1/EJ dx = [x - x^2/b + 1/3 x^3/b^2]_0^b 1/EJ$$

$$= (b - b + 1/3 b) 1/EJ = 1/3 b/EJ$$

$$L_{DG}^{xx} = \int_0^b (x^2/b^2) 1/EJ dx = [1/3 x^3/b^2]_0^b 1/EJ$$

$$= (1/3 b) 1/EJ = 1/3 b/EJ$$

$$L_{GA}^{xx} = \int_0^b (1/4 - 1/2 x/b + 1/4 x^2/b^2) 1/EJ dx = [1/4 x - 1/4 x^2/b + 1/12 x^3/b^2]_0^b 1/EJ$$

$$= (1/4 b - 1/4 b + 1/12 b) 1/EJ = 1/12 b/EJ$$

$$L_{AG}^{xx} = \int_0^b (1/4 x^2/b^2) 1/EJ dx = [1/12 x^3/b^2]_0^b 1/EJ$$

$$= (1/12 b) 1/EJ = 1/12 b/EJ$$

$$L_{FG}^{xo} = \int_0^b (7/8 x^2/b^2) Fb 1/EJ dx + \int_0^b (1/2 x/b) \theta dx = [7/24 x^3/b^2]_0^b Fb 1/EJ + [1/4 x^2/b]_0^b \theta$$

$$= (7/24 b) Fb 1/EJ + (1/4 b) \theta = 13/24 Fb^2/EJ$$

$$L_{GF}^{xo} = \int_0^b (7/8 - 7/4 x/b + 7/8 x^2/b^2) Fb 1/EJ dx + \int_0^b (-1/2 + 1/2 x/b) \theta dx$$

$$= [7/8 x - 7/8 x^2/b + 7/24 x^3/b^2]_0^b Fb 1/EJ + [-1/2 x + 1/4 x^2/b]_0^b \theta$$

$$= (7/8 b - 7/8 b + 7/24 b) Fb 1/EJ + (-1/2 b + 1/4 b) \theta = 13/24 Fb^2/EJ$$

$$L_{GD}^{xo} = \int_0^b (1/2 x/b - 1/2 x^2/b^2) Fb 1/EJ dx = [1/4 x^2/b - 1/6 x^3/b^2]_0^b Fb 1/EJ$$

$$= (1/4 b - 1/6 b) Fb 1/EJ = 1/12 Fb^2/EJ$$

$$L_{DG}^{xo} = \int_0^b (1/2 x/b - 1/2 x^2/b^2) Fb 1/EJ dx = [1/4 x^2/b - 1/6 x^3/b^2]_0^b Fb 1/EJ$$

$$= (1/4 b - 1/6 b) Fb 1/EJ = 1/12 Fb^2/EJ$$

$$L_{GA}^{xo} = \int_0^b (-3/8 + 1/2 x/b + 1/8 x^2/b^2 - 1/4 x^3/b^3) Fb 1/EJ dx$$

$$= [-3/8 x + 1/4 x^2/b + 1/24 x^3/b^2 - 1/16 x^4/b^3]_0^b Fb 1/EJ$$

$$= (-3/8 b + 1/4 b + 1/24 b - 1/16 b) Fb 1/EJ = -7/48 Fb^2/EJ$$

$$L_{AG}^{xo} = \int_0^b (-5/8 x^2/b^2 + 1/4 x^3/b^3) Fb 1/EJ dx = [-5/24 x^3/b^2 + 1/16 x^4/b^3]_0^b Fb 1/EJ$$

$$= (-5/24 b + 1/16 b) Fb 1/EJ = -7/48 Fb^2/EJ$$

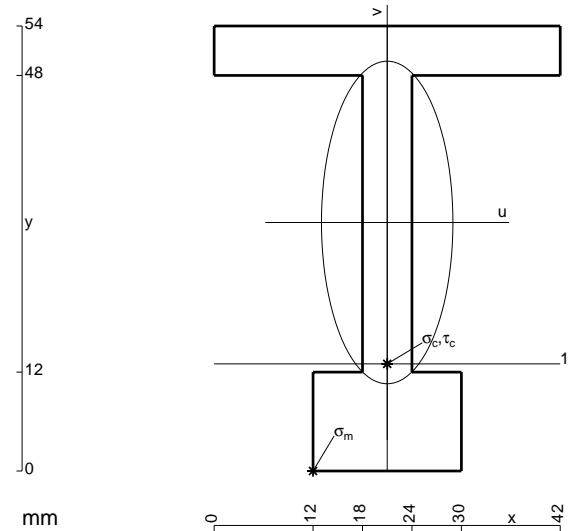

$A = 684. \text{ mm}^2$
 $J_u = 262207. \text{ mm}^4$
 $J_v = 43524. \text{ mm}^4$
 $y_g = 30.16 \text{ mm}$
 $T_y = -2280. \text{ N}$
 $M_x = -1732800. \text{ Nmm}$
 $x_m = 12. \text{ mm}$
 $u_m = -9. \text{ mm}$
 $v_m = -30.16 \text{ mm}$
 $\sigma_m = -Mv/J_u = -199.3 \text{ N/mm}^2$
 $x_c = 21. \text{ mm}$
 $y_c = 13. \text{ mm}$
 $v_c = -17.16 \text{ mm}$
 $\sigma_c = -Mv/J_u = -113.4 \text{ N/mm}^2$
 $\tau_c = 7.716 \text{ N/mm}^2$
 $\sigma_q = \sqrt{\sigma^2 + 3\tau^2} = 114.2 \text{ N/mm}^2$
 $S = 5324. \text{ mm}^3$

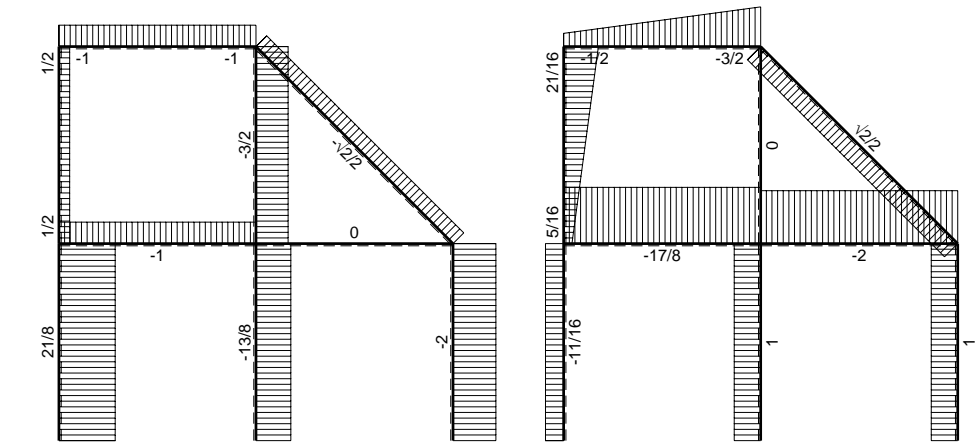
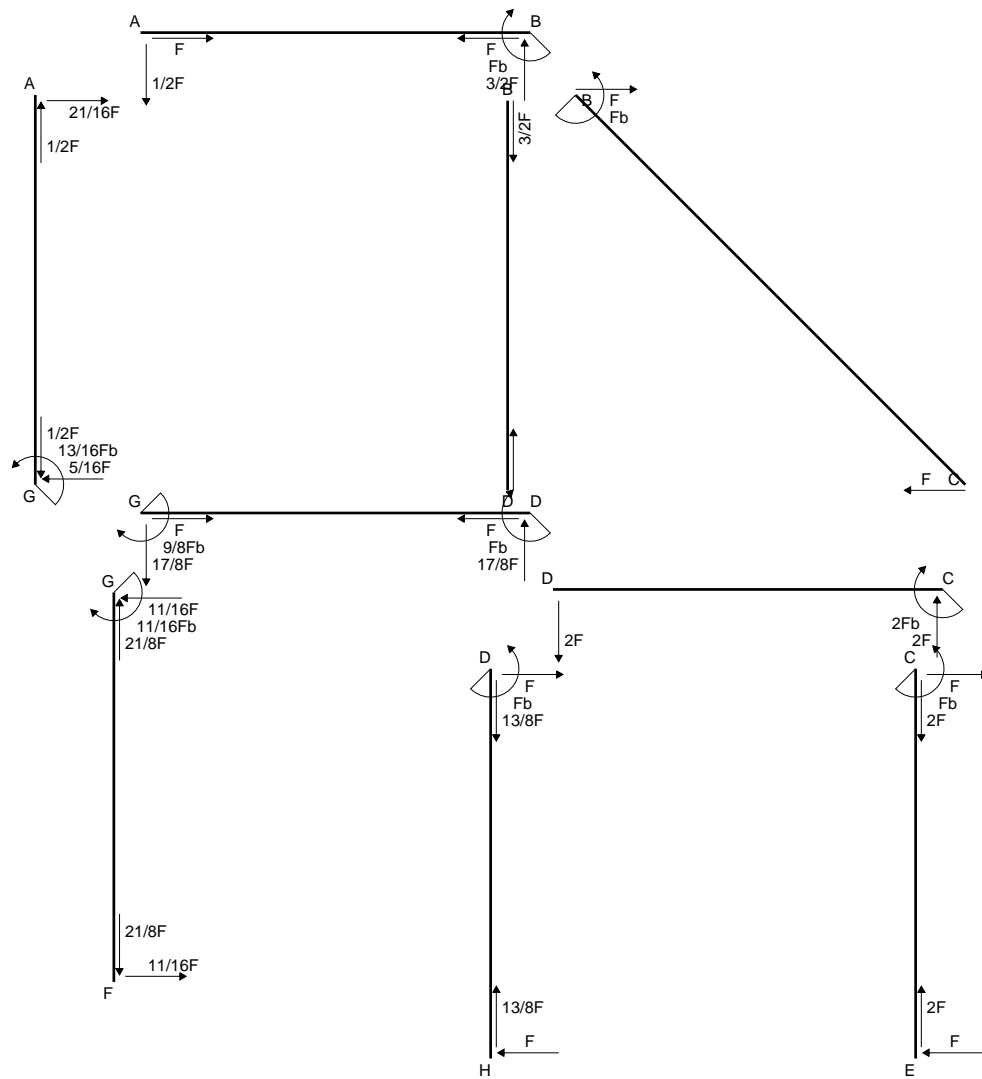

← ⊕ → F

↑ ⊕ ↓ F

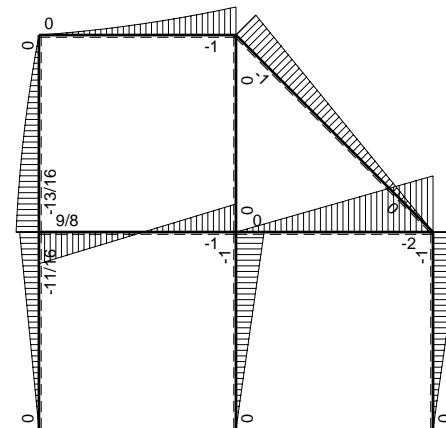

⊕ ⊖ F_b

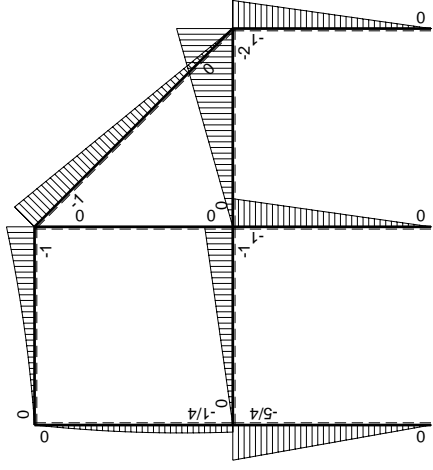
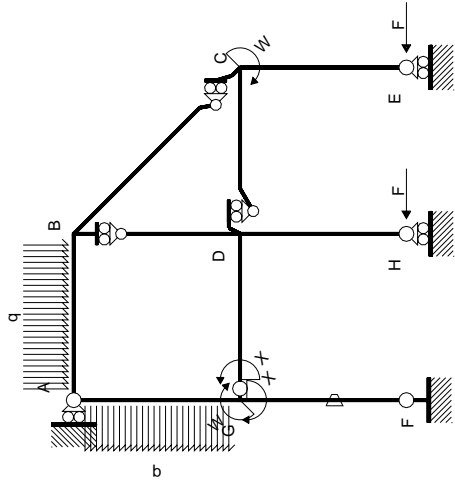

Schema di calcolo iperstatico

M_0 flessione da carichi assegnati

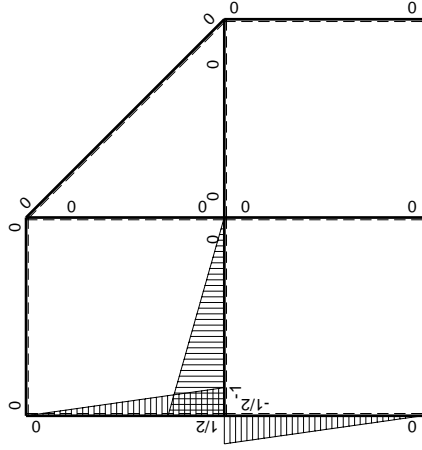

M_X flessione da iperstatica $X=1$

Quadro contributi PLV per iperstatica $X=W_{GD}$

→	$M_x(x)$	$M_o(x)$	θ	$M_x M_o$	$M_x \theta$	$M_x M_x$	$\int M_x(M_o/EJ+\theta)dx$	$\int X M_x M_x/EJdx$
AB b	0	$-1/2Fx-1/2qx^2$	0	0	0	0	0+0	0
BA b	0	$Fb-3/2Fx+1/2qx^2$	0	0	0	0	0	0
BC $\sqrt{2}b$	0	$-Fb+\sqrt{2}/2Fx$	0	0	0	0	0	0
BD b	0	0	0	0	0	0	0+0	0
DB b	0	0	0	0	0	0	0	0
DC b	0	$-2Fx$	0	0	0	0	0+0	0
CD b	0	$2Fb-2Fx$	0	0	0	0	0	0
CE b	0	$-Fb+Fx$	0	0	0	0	0+0	0
EC b	0	Fx	0	0	0	0	0	0
FG b	$-1/2x/b$	$-5/4Fx$	$-Fb/EJ$	$5/8Fx^2/b$	$1/2Fx/EJ$	$1/4x^2/b^2$	$(5/24+1/4)Fb^2/EJ$	$1/12Xb/EJ$
GF b	$1/2-1/2x/b$	$5/4Fb-5/4Fx$	Fb/EJ	$5/8Fb-5/4Fx+5/8Fx^2/b$	$1/2Fb/EJ-1/2Fx/EJ$	$1/4-1/2x/b+1/4x^2/b^2$		
GD b	$-1+x/b$	$-Fx$	0	$Fx-Fx^2/b$	0	$1-2x/b+x^2/b^2$	$(1/6+0)Fb^2/EJ$	$1/3Xb/EJ$
DG b	x/b	$Fb-Fx$	0	$Fx-Fx^2/b$	0	x^2/b^2		
DH b	0	$-Fb+Fx$	0	0	0	0	0+0	0
HD b	0	Fx	0	0	0	0	0	0
GA b	$1/2-1/2x/b$	$-1/4Fb-1/4Fx+1/2qx^2$	0	$-1/8Fb+3/8Fx^2/b-1/4qx^3/b$	0	$1/4-1/2x/b+1/4x^2/b^2$	$(-1/16+0)Fb^2/EJ$	$1/12Xb/EJ$
AG b	$-1/2x/b$	$3/4Fx-1/2qx^2$	0	$-3/8Fx^2/b+1/4qx^3/b$	0	$1/4x^2/b^2$		
	totali						$9/16Fb^2/EJ$	$1/2Xb/EJ$
	iperstatica $X=W_{GD}$						$-9/8Fb$	

Sviluppi di calcolo iperstatica

$$L_{FG}^{xx} = \int_0^b (1/4 x^2/b^2) 1/EJ dx = [1/12 x^3/b^2]_0^b 1/EJ$$

$$= (1/12 b) 1/EJ = 1/12 b/EJ$$

$$L_{GF}^{xx} = \int_0^b (1/4 - 1/2 x/b + 1/4 x^2/b^2) 1/EJ dx = [1/4 x - 1/4 x^2/b + 1/12 x^3/b^2]_0^b 1/EJ$$

$$= (1/4 b - 1/4 b + 1/12 b) 1/EJ = 1/12 b/EJ$$

$$L_{GD}^{xx} = \int_0^b (1 - 2 x/b + x^2/b^2) 1/EJ dx = [x - x^2/b + 1/3 x^3/b^2]_0^b 1/EJ$$

$$= (b - b + 1/3 b) 1/EJ = 1/3 b/EJ$$

$$L_{DG}^{xx} = \int_0^b (x^2/b^2) 1/EJ dx = [1/3 x^3/b^2]_0^b 1/EJ$$

$$= (1/3 b) 1/EJ = 1/3 b/EJ$$

$$L_{GA}^{xx} = \int_0^b (1/4 - 1/2 x/b + 1/4 x^2/b^2) 1/EJ dx = [1/4 x - 1/4 x^2/b + 1/12 x^3/b^2]_0^b 1/EJ$$

$$= (1/4 b - 1/4 b + 1/12 b) 1/EJ = 1/12 b/EJ$$

$$L_{AG}^{xx} = \int_0^b (1/4 x^2/b^2) 1/EJ dx = [1/12 x^3/b^2]_0^b 1/EJ$$

$$= (1/12 b) 1/EJ = 1/12 b/EJ$$

$$L_{FG}^{xo} = \int_0^b (5/8 x^2/b^2) Fb 1/EJ dx + \int_0^b (1/2 x/b) \theta dx = [5/24 x^3/b^2]_0^b Fb 1/EJ + [1/4 x^2/b]_0^b \theta$$

$$= (5/24 b) Fb 1/EJ + (1/4 b) \theta = 11/24 Fb^2/EJ$$

$$L_{GF}^{xo} = \int_0^b (5/8 - 5/4 x/b + 5/8 x^2/b^2) Fb 1/EJ dx + \int_0^b (-1/2 + 1/2 x/b) \theta dx$$

$$= [5/8 x - 5/8 x^2/b + 5/24 x^3/b^2]_0^b Fb 1/EJ + [-1/2 x + 1/4 x^2/b]_0^b \theta$$

$$= (5/8 b - 5/8 b + 5/24 b) Fb 1/EJ + (-1/2 b + 1/4 b) \theta = 11/24 Fb^2/EJ$$

$$L_{GD}^{xo} = \int_0^b (x/b - x^2/b^2) Fb 1/EJ dx = [1/2 x^2/b - 1/3 x^3/b^2]_0^b Fb 1/EJ$$

$$= (1/2 b - 1/3 b) Fb 1/EJ = 1/6 Fb^2/EJ$$

$$L_{DG}^{xo} = \int_0^b (x/b - x^2/b^2) Fb 1/EJ dx = [1/2 x^2/b - 1/3 x^3/b^2]_0^b Fb 1/EJ$$

$$= (1/2 b - 1/3 b) Fb 1/EJ = 1/6 Fb^2/EJ$$

$$L_{GA}^{xo} = \int_0^b (-1/8 + 3/8 x^2/b^2 - 1/4 x^3/b^3) Fb 1/EJ dx = [-1/8 x + 1/8 x^3/b^2 - 1/16 x^4/b^3]_0^b Fb 1/EJ$$

$$= (-1/8 b + 1/8 b - 1/16 b) Fb 1/EJ = -1/16 Fb^2/EJ$$

$$L_{AG}^{xo} = \int_0^b (-3/8 x^2/b^2 + 1/4 x^3/b^3) Fb 1/EJ dx = [-1/8 x^3/b^2 + 1/16 x^4/b^3]_0^b Fb 1/EJ$$

$$= (-1/8 b + 1/16 b) Fb 1/EJ = -1/16 Fb^2/EJ$$

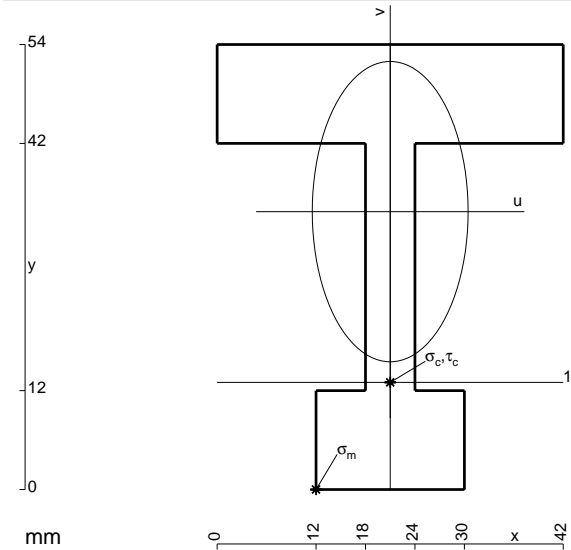

$$A = 900. \text{ mm}^2$$

$$J_u = 299017. \text{ mm}^4$$

$$J_v = 80460. \text{ mm}^4$$

$$y_g = 33.72 \text{ mm}$$

$$T_y = -2280. \text{ N}$$

$$M_x = -1846800. \text{ Nmm}$$

$$x_m = 12. \text{ mm}$$

$$u_m = -9. \text{ mm}$$

$$v_m = -33.72 \text{ mm}$$

$$\sigma_m = -Mv/J_u = -208.3 \text{ N/mm}^2$$

$$x_c = 21. \text{ mm}$$

$$y_c = 13. \text{ mm}$$

$$v_c = -20.72 \text{ mm}$$

$$\sigma_c = -Mv/J_u = -128. \text{ N/mm}^2$$

$$\tau_c = 7.771 \text{ N/mm}^2$$

$$\sigma_o = \sqrt{\sigma^2 + 3\tau^2} = 128.7 \text{ N/mm}^2$$

$$S = 6115. \text{ mm}^3$$

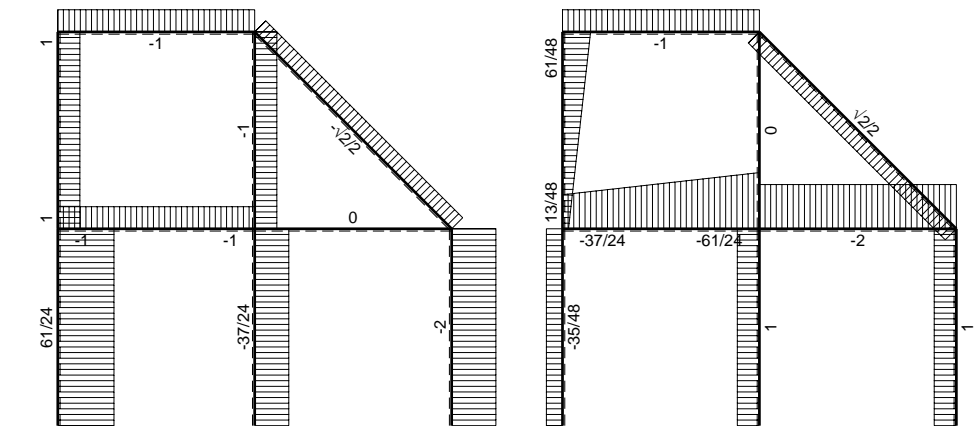
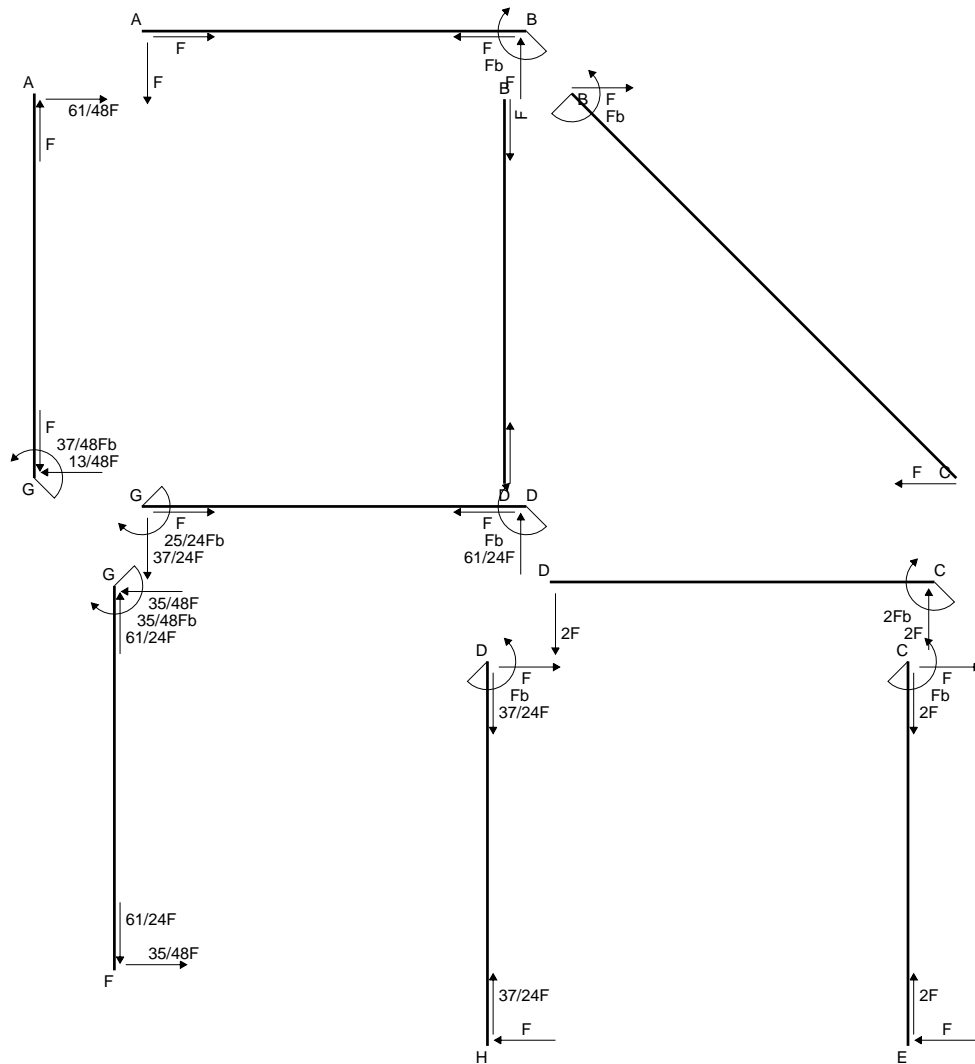

← ⊕ → F

↑ ⊕ ↓ F

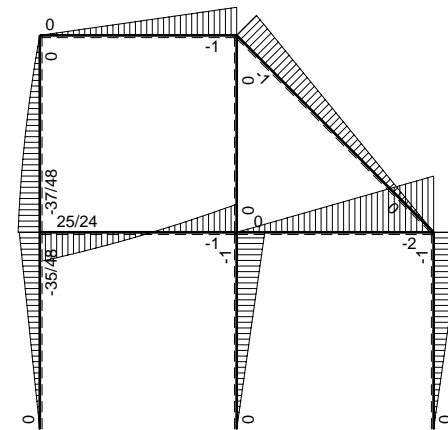

⊕ ⊖ F_b

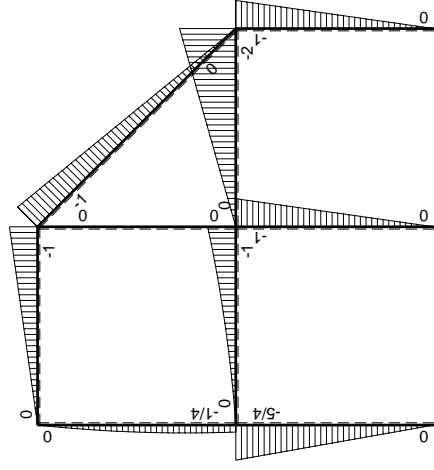
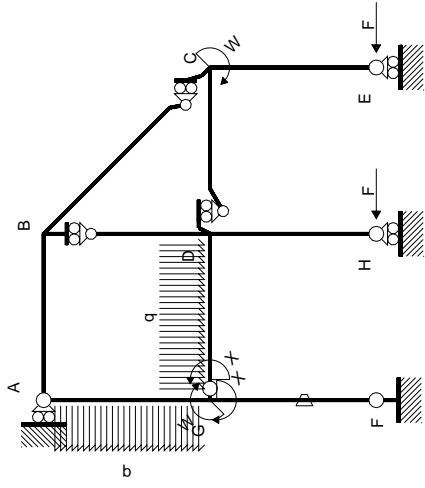

Schema di calcolo iperstatico

M_0 flessione da carichi assegnati

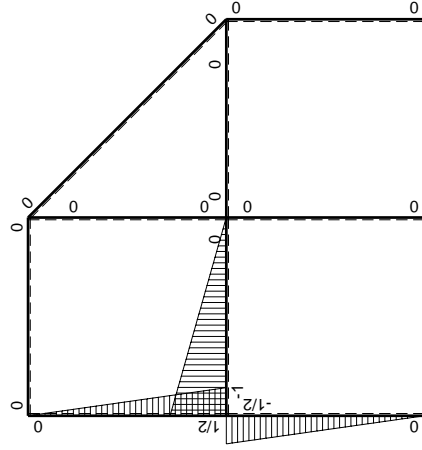

M_x flessione da iperstatica $X=1$

Quadro contributi PLV per iperstatica $X=W_{GD}$

→	$M_x(x)$	$M_o(x)$	θ	$M_x M_o$	$M_x \theta$	$M_x M_x$	$\int M_x(M_o/EJ+\theta)dx$	$\int X M_x M_x/EJdx$
AB b	0	-Fx	0	0	0	0	0+0	0
BA b	0	Fb-Fx	0	0	0	0	0	0
BC $\sqrt{2}b$	0	-Fb+ $\sqrt{2}/2Fx$	0	0	0	0	0	0
BD b	0	0	0	0	0	0	0+0	0
DB b	0	0	0	0	0	0	0	0
DC b	0	-2Fx	0	0	0	0	0+0	0
CD b	0	2Fb-2Fx	0	0	0	0	0	0
CE b	0	-Fb+Fx	0	0	0	0	0+0	0
EC b	0	Fx	0	0	0	0	0	0
FG b	-1/2x/b	-5/4Fx	-Fb/EJ	5/8Fx ² /b	1/2Fx/EJ	1/4x ² /b ²	(5/24+1/4)Fb ² /EJ	1/12Xb/EJ
GF b	1/2-1/2x/b	5/4Fb-5/4Fx	Fb/EJ	5/8Fb-5/4Fx+5/8Fx ² /b	1/2Fb/EJ-1/2Fx/EJ	1/4-1/2x/b+1/4x ² /b ²		
GD b	-1+x/b	-1/2Fx-1/2qx ²	0	1/2Fx-1/2qx ³ /b	0	1-2x/b+x ² /b ²	(1/8+0)Fb ² /EJ	1/3Xb/EJ
DG b	x/b	Fb-3/2Fx+1/2qx ²	0	Fx-3/2Fx ² /b+1/2qx ³ /b	0	x ² /b ²		
DH b	0	-Fb+Fx	0	0	0	0	0+0	0
HD b	0	Fx	0	0	0	0	0	0
GA b	1/2-1/2x/b	-1/4Fb-1/4Fx+1/2qx ²	0	-1/8Fb+3/8Fx ² /b-1/4qx ³ /b	0	1/4-1/2x/b+1/4x ² /b ²	(-1/16+0)Fb ² /EJ	1/12Xb/EJ
AG b	-1/2x/b	3/4Fx-1/2qx ²	0	-3/8Fx ² /b+1/4qx ³ /b	0	1/4x ² /b ²		
	totali						25/48Fb ² /EJ	1/2Xb/EJ
	iperstatica $X=W_{GD}$						-25/24Fb	

Sviluppi di calcolo iperstatica

$$L_{FG}^{xx} = \int_0^b (1/4 x^2/b^2) 1/EJ dx = [1/12 x^3/b^2]_0^b 1/EJ$$

$$= (1/12 b) 1/EJ = 1/12 b/EJ$$

$$L_{GF}^{xx} = \int_0^b (1/4 - 1/2 x/b + 1/4 x^2/b^2) 1/EJ dx = [1/4 x - 1/4 x^2/b + 1/12 x^3/b^2]_0^b 1/EJ$$

$$= (1/4 b - 1/4 b + 1/12 b) 1/EJ = 1/12 b/EJ$$

$$L_{GD}^{xx} = \int_0^b (1 - 2 x/b + x^2/b^2) 1/EJ dx = [x - x^2/b + 1/3 x^3/b^2]_0^b 1/EJ$$

$$= (b - b + 1/3 b) 1/EJ = 1/3 b/EJ$$

$$L_{DG}^{xx} = \int_0^b (x^2/b^2) 1/EJ dx = [1/3 x^3/b^2]_0^b 1/EJ$$

$$= (1/3 b) 1/EJ = 1/3 b/EJ$$

$$L_{GA}^{xx} = \int_0^b (1/4 - 1/2 x/b + 1/4 x^2/b^2) 1/EJ dx = [1/4 x - 1/4 x^2/b + 1/12 x^3/b^2]_0^b 1/EJ$$

$$= (1/4 b - 1/4 b + 1/12 b) 1/EJ = 1/12 b/EJ$$

$$L_{AG}^{xx} = \int_0^b (1/4 x^2/b^2) 1/EJ dx = [1/12 x^3/b^2]_0^b 1/EJ$$

$$= (1/12 b) 1/EJ = 1/12 b/EJ$$

$$L_{FG}^{xo} = \int_0^b (5/8 x^2/b^2) Fb 1/EJ dx + \int_0^b (1/2 x/b) \theta dx = [5/24 x^3/b^2]_0^b Fb 1/EJ + [1/4 x^2/b]_0^b \theta$$

$$= (5/24 b) Fb 1/EJ + (1/4 b) \theta = 11/24 Fb^2/EJ$$

$$L_{GF}^{xo} = \int_0^b (5/8 - 5/4 x/b + 5/8 x^2/b^2) Fb 1/EJ dx + \int_0^b (-1/2 + 1/2 x/b) \theta dx$$

$$= [5/8 x - 5/8 x^2/b + 5/24 x^3/b^2]_0^b Fb 1/EJ + [-1/2 x + 1/4 x^2/b]_0^b \theta$$

$$= (5/8 b - 5/8 b + 5/24 b) Fb 1/EJ + (-1/2 b + 1/4 b) \theta = 11/24 Fb^2/EJ$$

$$L_{GD}^{xo} = \int_0^b (1/2 x/b - 1/2 x^3/b^3) Fb 1/EJ dx = [1/4 x^2/b - 1/8 x^4/b^3]_0^b Fb 1/EJ$$

$$= (1/4 b - 1/8 b) Fb 1/EJ = 1/8 Fb^2/EJ$$

$$L_{DG}^{xo} = \int_0^b (x/b - 3/2 x^2/b^2 + 1/2 x^3/b^3) Fb 1/EJ dx = [1/2 x^2/b - 1/2 x^3/b^2 + 1/8 x^4/b^3]_0^b Fb 1/EJ$$

$$= (1/2 b - 1/2 b + 1/8 b) Fb 1/EJ = 1/8 Fb^2/EJ$$

$$L_{GA}^{xo} = \int_0^b (-1/8 + 3/8 x^2/b^2 - 1/4 x^3/b^3) Fb 1/EJ dx = [-1/8 x + 1/8 x^3/b^2 - 1/16 x^4/b^3]_0^b Fb 1/EJ$$

$$= (-1/8 b + 1/8 b - 1/16 b) Fb 1/EJ = -1/16 Fb^2/EJ$$

$$L_{AG}^{xo} = \int_0^b (-3/8 x^2/b^2 + 1/4 x^3/b^3) Fb 1/EJ dx = [-1/8 x^3/b^2 + 1/16 x^4/b^3]_0^b Fb 1/EJ$$

$$= (-1/8 b + 1/16 b) Fb 1/EJ = -1/16 Fb^2/EJ$$

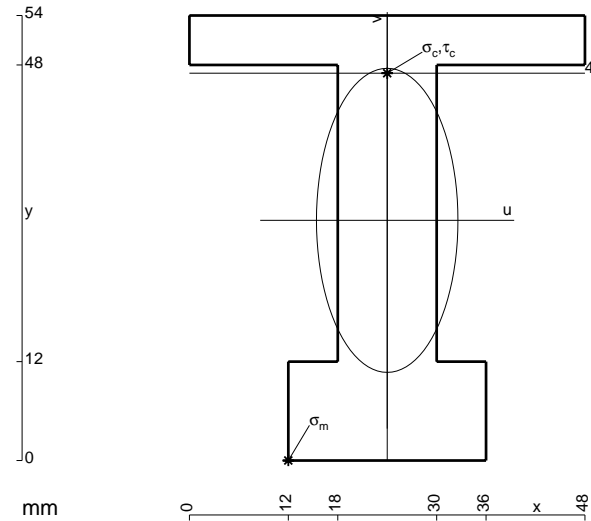

$A = 1008. \text{ mm}^2$
 $J_u = 343131. \text{ mm}^4$
 $J_v = 74304. \text{ mm}^4$
 $y_g = 29.14 \text{ mm}$
 $T_y = -3000. \text{ N}$
 $M_x = -2580000. \text{ Nmm}$
 $x_m = 12. \text{ mm}$
 $u_m = -12. \text{ mm}$
 $v_m = -29.14 \text{ mm}$
 $\sigma_m = -Mv/J_u = -219.1 \text{ N/mm}^2$
 $x_c = 24. \text{ mm}$
 $y_c = 47. \text{ mm}$
 $v_c = 17.86 \text{ mm}$
 $\sigma_c = -Mv/J_u = 134.3 \text{ N/mm}^2$
 $\tau_c = 4.747 \text{ N/mm}^2$
 $\sigma_o = \sqrt{\sigma^2 + 3\tau^2} = 134.5 \text{ N/mm}^2$
 $S = 6515. \text{ mm}^3$

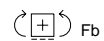
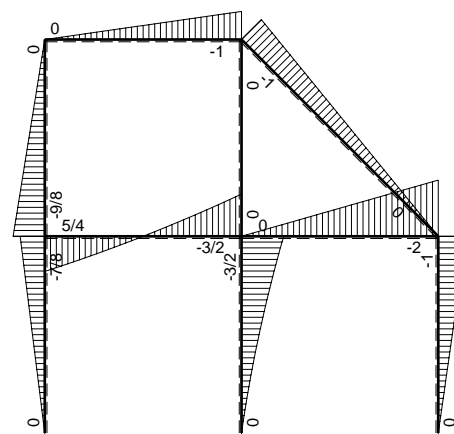
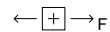
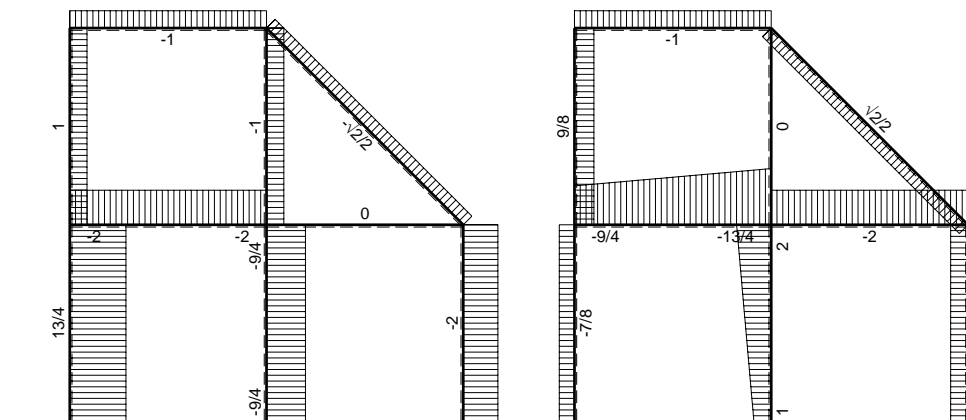
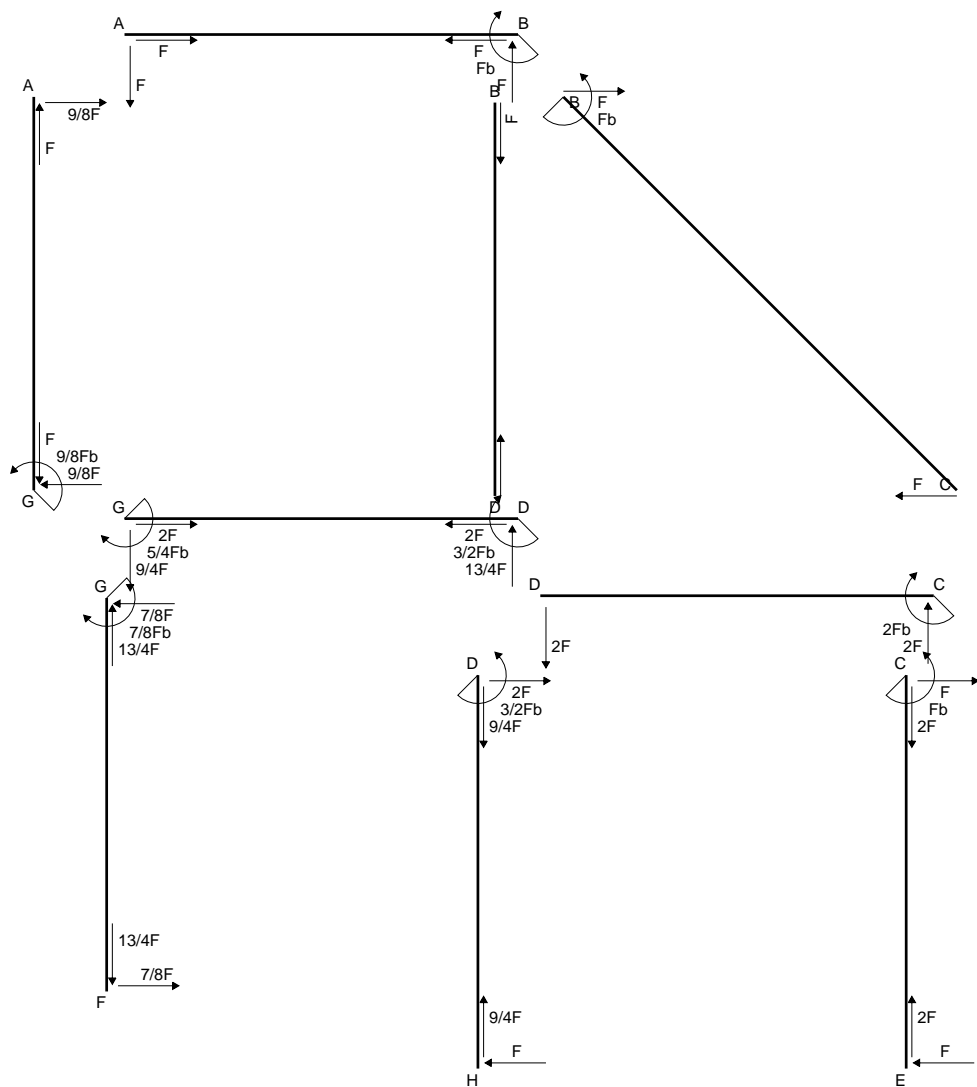

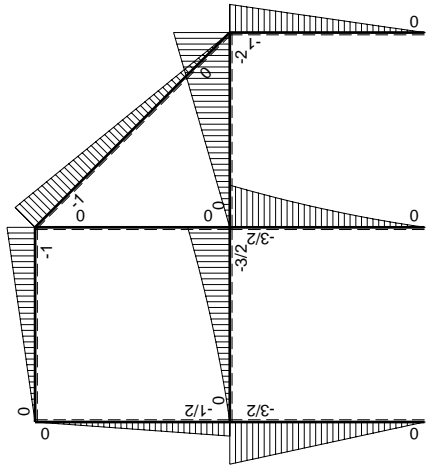
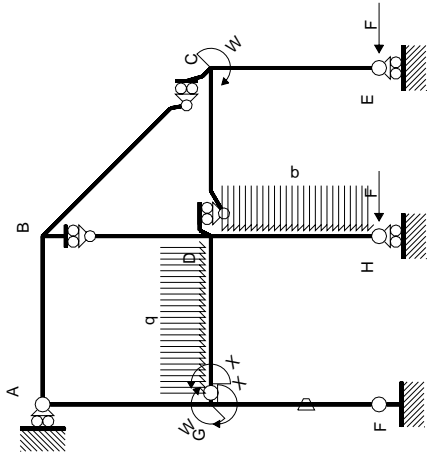

Schema di calcolo iperstatico

M_0 flessione da carichi assegnati

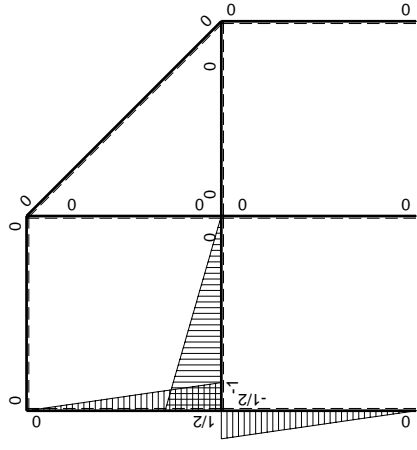

M_x flessione da iperstatica $X=1$

Quadro contributi PLV per iperstatica $X=W_{GD}$

→	$M_x(x)$	$M_o(x)$	θ	$M_x M_o$	$M_x \theta$	$M_x M_x$	$\int M_x(M_o/EJ+\theta)dx$	$\int X M_x M_x/EJdx$
AB b	0	-Fx	0	0	0	0	0+0	0
BA b	0	Fb-Fx	0	0	0	0		
BC $\sqrt{2}b$	0	-Fb+ $\sqrt{2}/2Fx$	0	0	0	0	0	0
BD b	0	0	0	0	0	0	0+0	0
DB b	0	0	0	0	0	0		
DC b	0	-2Fx	0	0	0	0	0+0	0
CD b	0	2Fb-2Fx	0	0	0	0		
CE b	0	-Fb+Fx	0	0	0	0	0+0	0
EC b	0	Fx	0	0	0	0		
FG b	-1/2x/b	-3/2Fx	-Fb/EJ	3/4Fx ² /b	1/2Fx/EJ	1/4x ² /b ²	(1/4+1/4)Fb ² /EJ	1/12Xb/EJ
GF b	1/2-1/2x/b	3/2Fb-3/2Fx	Fb/EJ	3/4Fb-3/2Fx+3/4Fx ² /b	1/2Fb/EJ-1/2Fx/EJ	1/4-1/2x/b+1/4x ² /b ²		
GD b	-1+x/b	-Fx-1/2qx ²	0	Fx-1/2Fx ² /b-1/2qx ³ /b	0	1-2x/b+x ² /b ²	(5/24+0)Fb ² /EJ	1/3Xb/EJ
DG b	x/b	3/2Fb-2Fx+1/2qx ²	0	3/2Fx-2Fx ² /b+1/2qx ³ /b	0	x ² /b ²		
DH b	0	-3/2Fb+2Fx-1/2qx ²	0	0	0	0	0+0	0
HD b	0	Fx+1/2qx ²	0	0	0	0		
GA b	1/2-1/2x/b	-1/2Fb+1/2Fx	0	-1/4Fb+1/2Fx-1/4Fx ² /b	0	1/4-1/2x/b+1/4x ² /b ²	(-1/12+0)Fb ² /EJ	1/12Xb/EJ
AG b	-1/2x/b	1/2Fx	0	-1/4Fx ² /b	0	1/4x ² /b ²		
	totali						5/8Fb ² /EJ	1/2Xb/EJ
	iperstatica $X=W_{GD}$						-5/4Fb	

Sviluppi di calcolo iperstatica

$$L_{FG}^{xx} = \int_0^b (1/4 x^2/b^2) 1/EJ dx = [1/12 x^3/b^2]_0^b 1/EJ$$

$$= (1/12 b) 1/EJ = 1/12 b/EJ$$

$$L_{GF}^{xx} = \int_0^b (1/4 - 1/2 x/b + 1/4 x^2/b^2) 1/EJ dx = [1/4 x - 1/4 x^2/b + 1/12 x^3/b^2]_0^b 1/EJ$$

$$= (1/4 b - 1/4 b + 1/12 b) 1/EJ = 1/12 b/EJ$$

$$L_{GD}^{xx} = \int_0^b (1 - 2 x/b + x^2/b^2) 1/EJ dx = [x - x^2/b + 1/3 x^3/b^2]_0^b 1/EJ$$

$$= (b - b + 1/3 b) 1/EJ = 1/3 b/EJ$$

$$L_{DG}^{xx} = \int_0^b (x^2/b^2) 1/EJ dx = [1/3 x^3/b^2]_0^b 1/EJ$$

$$= (1/3 b) 1/EJ = 1/3 b/EJ$$

$$L_{GA}^{xx} = \int_0^b (1/4 - 1/2 x/b + 1/4 x^2/b^2) 1/EJ dx = [1/4 x - 1/4 x^2/b + 1/12 x^3/b^2]_0^b 1/EJ$$

$$= (1/4 b - 1/4 b + 1/12 b) 1/EJ = 1/12 b/EJ$$

$$L_{AG}^{xx} = \int_0^b (1/4 x^2/b^2) 1/EJ dx = [1/12 x^3/b^2]_0^b 1/EJ$$

$$= (1/12 b) 1/EJ = 1/12 b/EJ$$

$$L_{FG}^{xo} = \int_0^b (3/4 x^2/b^2) Fb 1/EJ dx + \int_0^b (1/2 x/b) \theta dx = [1/4 x^3/b^2]_0^b Fb 1/EJ + [1/4 x^2/b]_0^b \theta$$

$$= (1/4 b) Fb 1/EJ + (1/4 b) \theta = 1/2 Fb^2/EJ$$

$$L_{GF}^{xo} = \int_0^b (3/4 - 3/2 x/b + 3/4 x^2/b^2) Fb 1/EJ dx + \int_0^b (-1/2 + 1/2 x/b) \theta dx$$

$$= [3/4 x - 3/4 x^2/b + 1/4 x^3/b^2]_0^b Fb 1/EJ + [-1/2 x + 1/4 x^2/b]_0^b \theta$$

$$= (3/4 b - 3/4 b + 1/4 b) Fb 1/EJ + (-1/2 b + 1/4 b) \theta = 1/2 Fb^2/EJ$$

$$L_{GD}^{xo} = \int_0^b (x/b - 1/2 x^2/b^2 - 1/2 x^3/b^3) Fb 1/EJ dx = [1/2 x^2/b - 1/6 x^3/b^2 - 1/8 x^4/b^3]_0^b Fb 1/EJ$$

$$= (1/2 b - 1/6 b - 1/8 b) Fb 1/EJ = 5/24 Fb^2/EJ$$

$$L_{DG}^{xo} = \int_0^b (3/2 x/b - 2 x^2/b^2 + 1/2 x^3/b^3) Fb 1/EJ dx = [3/4 x^2/b - 2/3 x^3/b^2 + 1/8 x^4/b^3]_0^b Fb 1/EJ$$

$$= (3/4 b - 2/3 b + 1/8 b) Fb 1/EJ = 5/24 Fb^2/EJ$$

$$L_{GA}^{xo} = \int_0^b (-1/4 + 1/2 x/b - 1/4 x^2/b^2) Fb 1/EJ dx = [-1/4 x + 1/4 x^2/b - 1/12 x^3/b^2]_0^b Fb 1/EJ$$

$$= (-1/4 b + 1/4 b - 1/12 b) Fb 1/EJ = -1/12 Fb^2/EJ$$

$$L_{AG}^{xo} = \int_0^b (-1/4 x^2/b^2) Fb 1/EJ dx = [-1/12 x^3/b^2]_0^b Fb 1/EJ$$

$$= (-1/12 b) Fb 1/EJ = -1/12 Fb^2/EJ$$

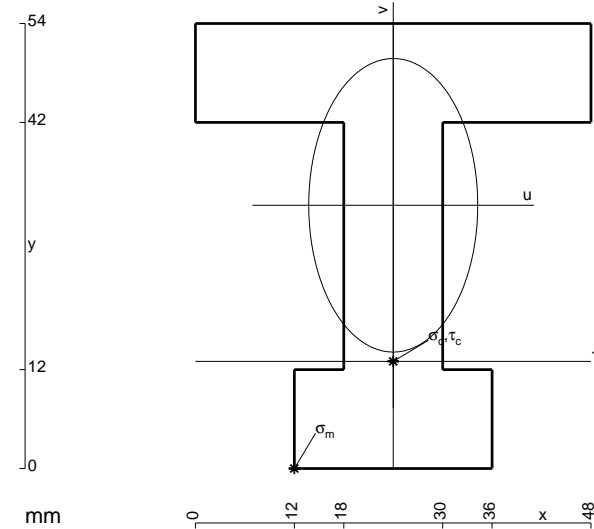

- A = 1224. mm²
- J_u = 388508. mm⁴
- J_v = 128736. mm⁴
- y_g = 31.94 mm
- T_y = -3060. N
- M_x = -2784600. Nmm
- x_m = 12. mm
- u_m = -12. mm
- v_m = -31.94 mm
- σ_m = -Mv/J_u = -228.9 N/mm²
- x_c = 24. mm
- y_c = 13. mm
- v_c = -18.94 mm
- σ_c = -Mv/J_u = -135.8 N/mm²
- τ_c = 5.057 N/mm²
- σ_q = √(σ² + 3τ²) = 136. N/mm²
- S = 7704. mm³

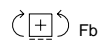
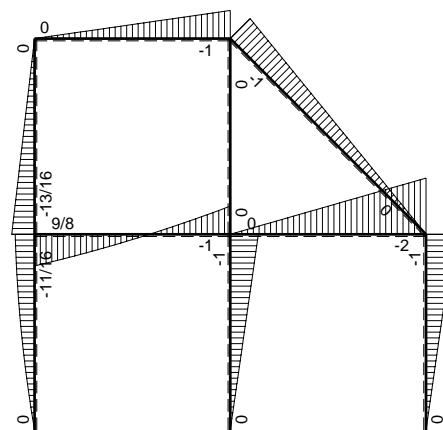
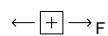
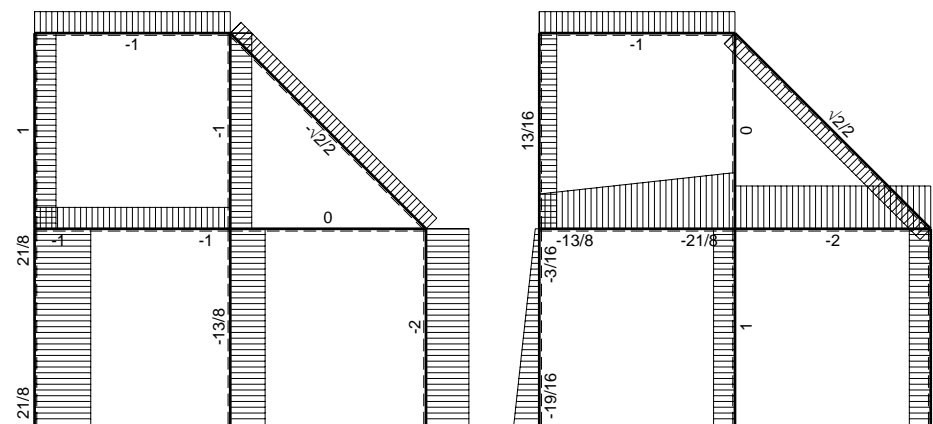
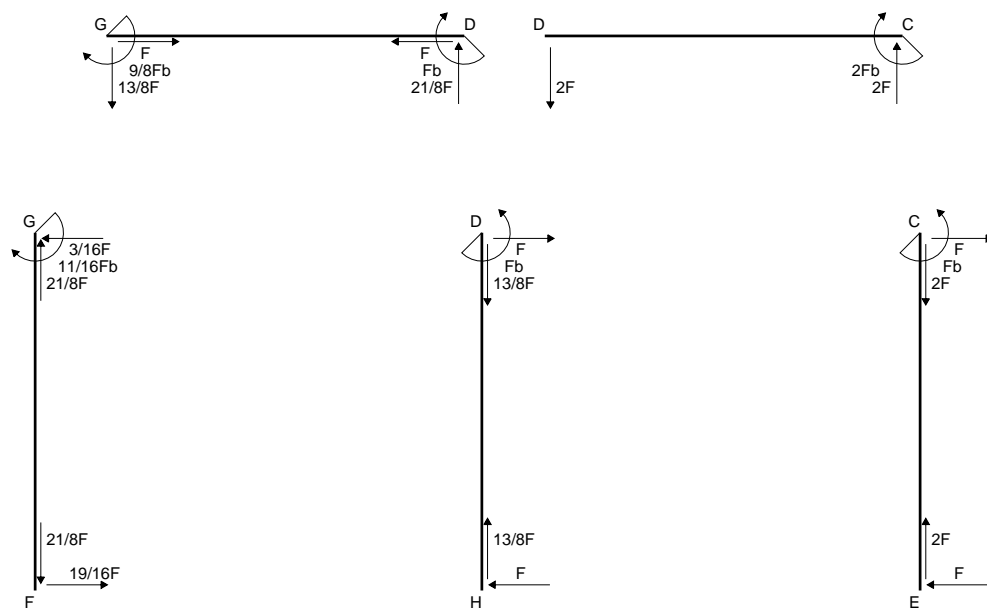
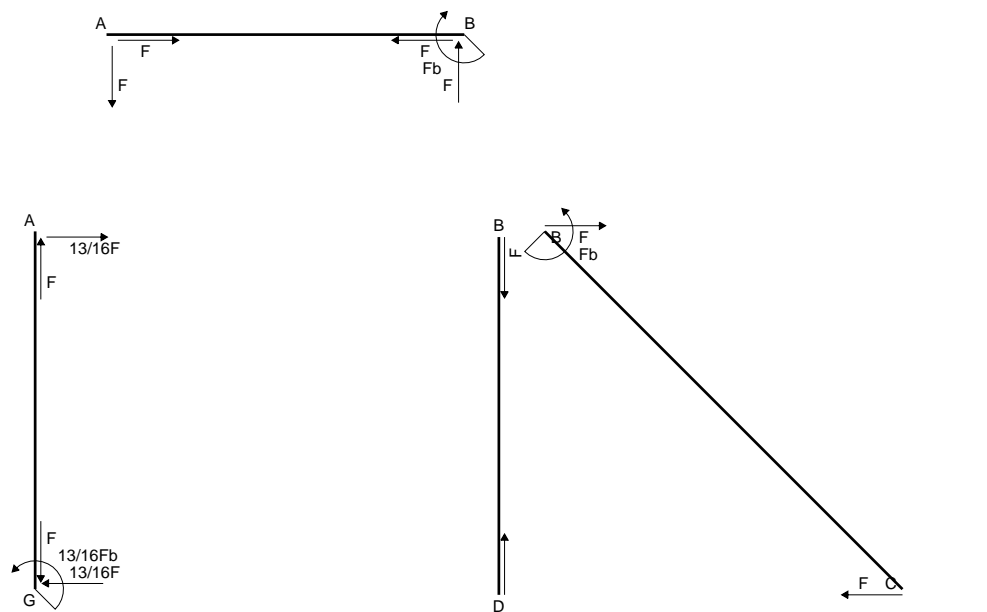

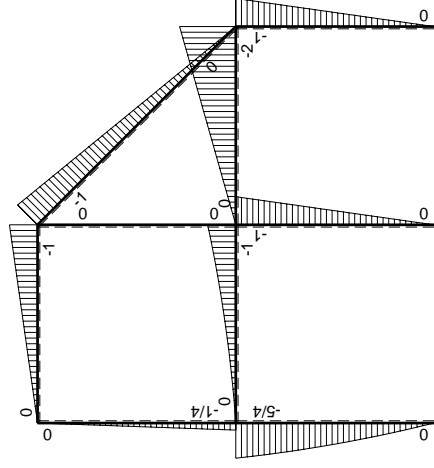
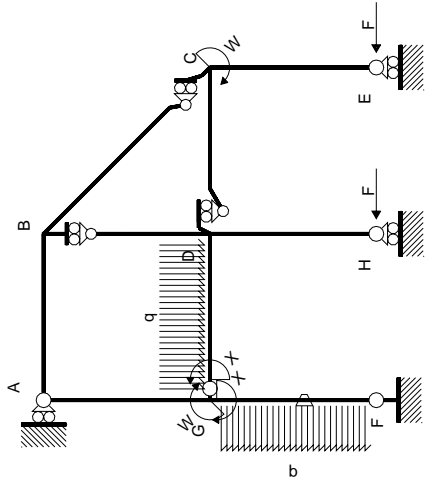

Schema di calcolo iperstatico

M_0 flessione da carichi assegnati

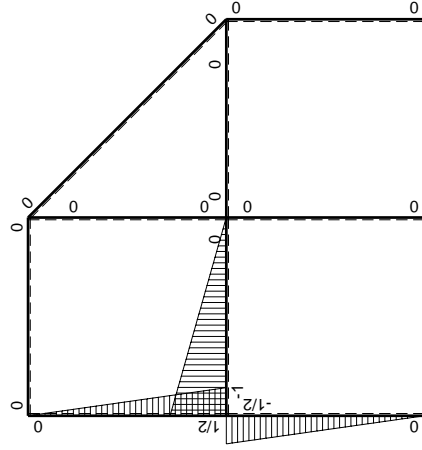

M_1 flessione da iperstatica $X=1$

Quadro contributi PLV per iperstatica $X=W_{GD}$

→	$M_x(x)$	$M_o(x)$	θ	$M_x M_o$	$M_x \theta$	$M_x M_x$	$\int M_x(M_o/EJ+\theta)dx$	$\int X M_x M_x / EJ dx$	
AB b	0	-Fx	0	0	0	0	0+0	0	
BA b	0	Fb-Fx	0	0	0	0	0	0	
BC $\sqrt{2}b$	0	-Fb+ $\sqrt{2}/2Fx$	0	0	0	0	0	0	
BD b	0	0	0	0	0	0	0+0	0	
DB b	0	0	0	0	0	0	0	0	
DC b	0	-2Fx	0	0	0	0	0+0	0	
CD b	0	2Fb-2Fx	0	0	0	0	0	0	
CE b	0	-Fb+Fx	0	0	0	0	0+0	0	
EC b	0	Fx	0	0	0	0	0	0	
FG b	-1/2x/b	-7/4Fx+1/2qx ²	-Fb/EJ	7/8Fx ² /b-1/4qx ³ /b	1/2Fx/EJ	1/4x ² /b ²	(11/48+1/4)Fb ² /EJ	1/12Xb/EJ	
GF b	1/2-1/2x/b	5/4Fb-3/4Fx-1/2qx ²	Fb/EJ	5/8Fb-Fx+1/8Fx ² /b+1/4qx ³ /b	1/2Fb/EJ-1/2Fx/EJ	1/4-1/2x/b+1/4x ² /b ²			
GD b	-1+x/b	-1/2Fx-1/2qx ²	0	1/2Fx-1/2qx ³ /b	0	1-2x/b+x ² /b ²	(1/8+0)Fb ² /EJ	1/3Xb/EJ	
DG b	x/b	Fb-3/2Fx+1/2qx ²	0	Fx-3/2Fx ² /b+1/2qx ³ /b	0	x ² /b ²			
DH b	0	-Fb+Fx	0	0	0	0	0+0	0	
HD b	0	Fx	0	0	0	0	0	0	
GA b	1/2-1/2x/b	-1/4Fb+1/4Fx	0	-1/8Fb+1/4Fx-1/8Fx ² /b	0	1/4-1/2x/b+1/4x ² /b ²	(-1/24+0)Fb ² /EJ	1/12Xb/EJ	
AG b	-1/2x/b	1/4Fx	0	-1/8Fx ² /b	0	1/4x ² /b ²			
	totali							9/16Fb ² /EJ	1/2Xb/EJ
	iperstatica $X=W_{GD}$							-9/8Fb	

Sviluppi di calcolo iperstatica

$$L_{FG}^{xx} = \int_0^b (1/4 x^2/b^2) 1/EJ dx = [1/12 x^3/b^2]_0^b 1/EJ$$

$$= (1/12 b) 1/EJ = 1/12 b/EJ$$

$$L_{GF}^{xx} = \int_0^b (1/4 - 1/2 x/b + 1/4 x^2/b^2) 1/EJ dx = [1/4 x - 1/4 x^2/b + 1/12 x^3/b^2]_0^b 1/EJ$$

$$= (1/4 b - 1/4 b + 1/12 b) 1/EJ = 1/12 b/EJ$$

$$L_{GD}^{xx} = \int_0^b (1 - 2 x/b + x^2/b^2) 1/EJ dx = [x - x^2/b + 1/3 x^3/b^2]_0^b 1/EJ$$

$$= (b - b + 1/3 b) 1/EJ = 1/3 b/EJ$$

$$L_{DG}^{xx} = \int_0^b (x^2/b^2) 1/EJ dx = [1/3 x^3/b^2]_0^b 1/EJ$$

$$= (1/3 b) 1/EJ = 1/3 b/EJ$$

$$L_{GA}^{xx} = \int_0^b (1/4 - 1/2 x/b + 1/4 x^2/b^2) 1/EJ dx = [1/4 x - 1/4 x^2/b + 1/12 x^3/b^2]_0^b 1/EJ$$

$$= (1/4 b - 1/4 b + 1/12 b) 1/EJ = 1/12 b/EJ$$

$$L_{AG}^{xx} = \int_0^b (1/4 x^2/b^2) 1/EJ dx = [1/12 x^3/b^2]_0^b 1/EJ$$

$$= (1/12 b) 1/EJ = 1/12 b/EJ$$

$$L_{FG}^{x_0} = \int_0^b (7/8 x^2/b^2 - 1/4 x^3/b^3) Fb 1/EJ dx + \int_0^b (1/2 x/b) \theta dx$$

$$= [7/24 x^3/b^2 - 1/16 x^4/b^3]_0^b Fb 1/EJ + [1/4 x^2/b]_0^b \theta$$

$$= (7/24 b - 1/16 b) Fb 1/EJ + (1/4 b) \theta = 23/48 Fb^2/EJ$$

$$L_{GF}^{x_0} = \int_0^b (5/8 - x/b + 1/8 x^2/b^2 + 1/4 x^3/b^3) Fb 1/EJ dx + \int_0^b (-1/2 + 1/2 x/b) \theta dx$$

$$= [5/8 x - 1/2 x^2/b + 1/24 x^3/b^2 + 1/16 x^4/b^3]_0^b Fb 1/EJ + [-1/2 x + 1/4 x^2/b]_0^b \theta$$

$$= (5/8 b - 1/2 b + 1/24 b + 1/16 b) Fb 1/EJ + (-1/2 b + 1/4 b) \theta = 23/48 Fb^2/EJ$$

$$L_{GD}^{x_0} = \int_0^b (1/2 x/b - 1/2 x^3/b^3) Fb 1/EJ dx = [1/4 x^2/b - 1/8 x^4/b^3]_0^b Fb 1/EJ$$

$$= (1/4 b - 1/8 b) Fb 1/EJ = 1/8 Fb^2/EJ$$

$$L_{DG}^{x_0} = \int_0^b (x/b - 3/2 x^2/b^2 + 1/2 x^3/b^3) Fb 1/EJ dx = [1/2 x^2/b - 1/2 x^3/b^2 + 1/8 x^4/b^3]_0^b Fb 1/EJ$$

$$= (1/2 b - 1/2 b + 1/8 b) Fb 1/EJ = 1/8 Fb^2/EJ$$

$$L_{GA}^{x_0} = \int_0^b (-1/8 + 1/4 x/b - 1/8 x^2/b^2) Fb 1/EJ dx = [-1/8 x + 1/8 x^2/b - 1/24 x^3/b^2]_0^b Fb 1/EJ$$

$$= (-1/8 b + 1/8 b - 1/24 b) Fb 1/EJ = -1/24 Fb^2/EJ$$

$$L_{AG}^{x_0} = \int_0^b (-1/8 x^2/b^2) Fb 1/EJ dx = [-1/24 x^3/b^2]_0^b Fb 1/EJ$$

$$= (-1/24 b) Fb 1/EJ = -1/24 Fb^2/EJ$$

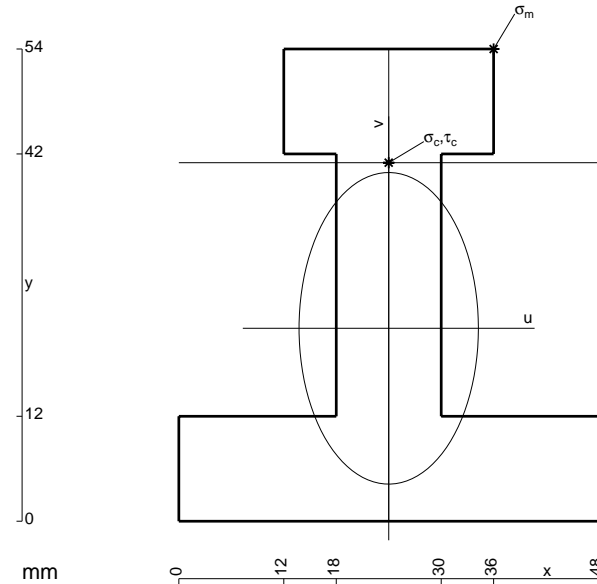

- A = 1224. mm²
- J_u = 388508. mm⁴
- J_v = 128736. mm⁴
- y_g = 22.06 mm
- T_y = -3040. N
- M_x = -2918400. Nmm
- x_m = 36. mm
- y_m = 54. mm
- u_m = 12. mm
- v_m = 31.94 mm
- σ_m = -Mv/J_u = 239.9 N/mm²
- x_c = 24. mm
- y_c = 41. mm
- v_c = 18.94 mm
- σ_c = -Mv/J_u = 142.3 N/mm²
- τ_c = 5.024 N/mm²
- σ_σ = √σ²+3τ² = 142.5 N/mm²
- S = 7704. mm³

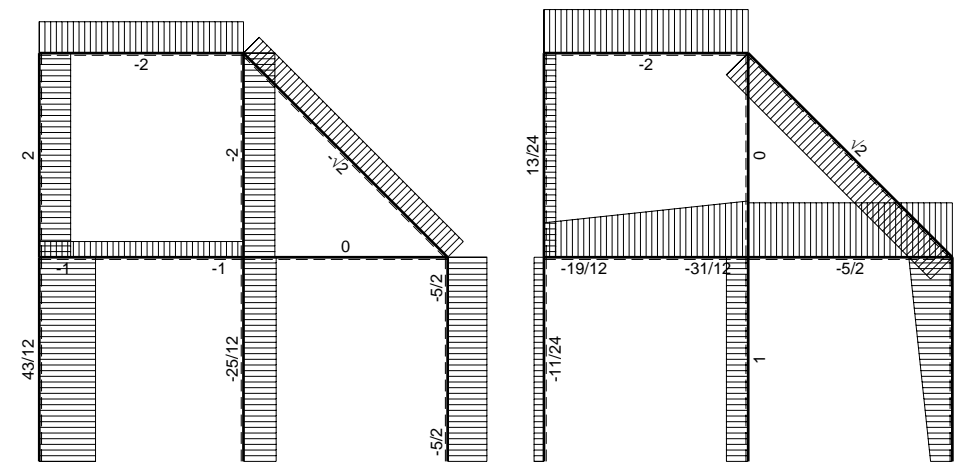
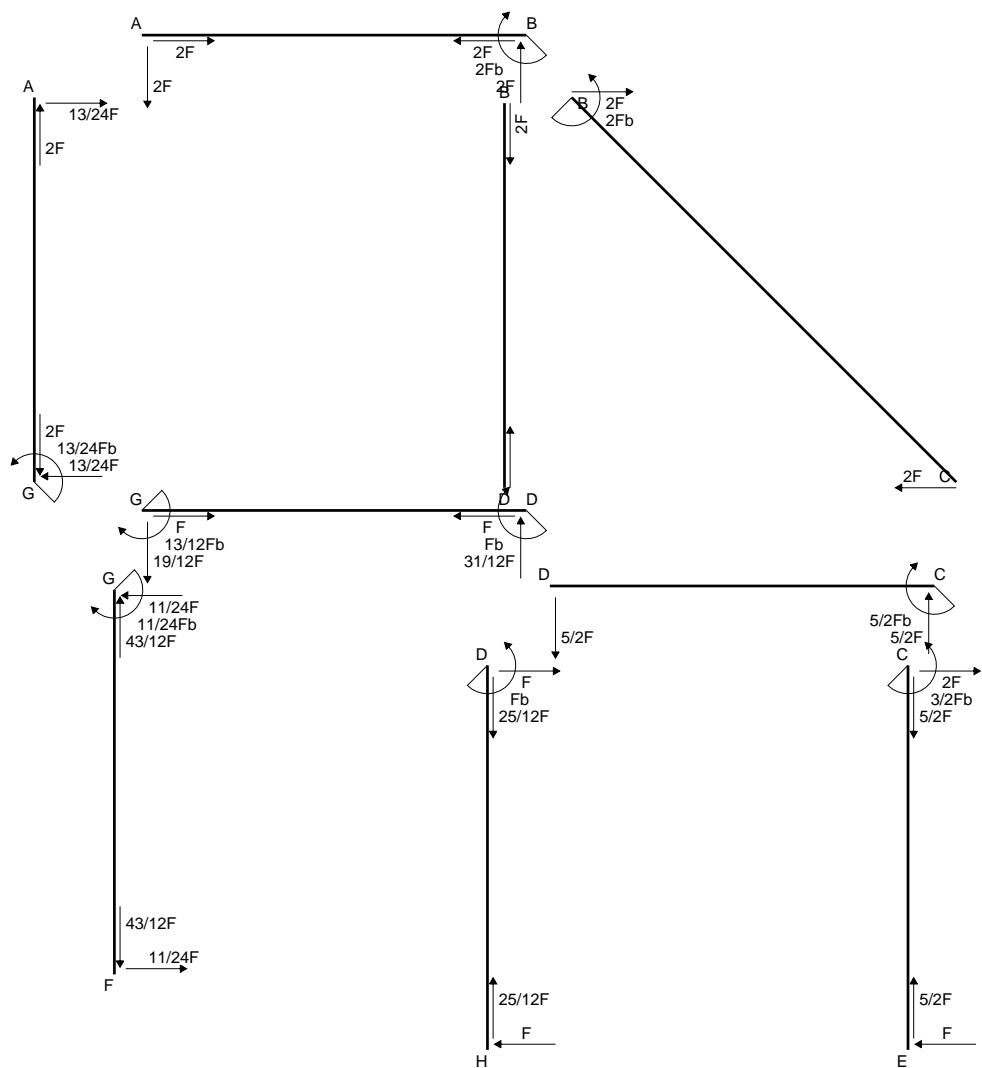

← ⊕ → F

↑ ⊕ ↓ F

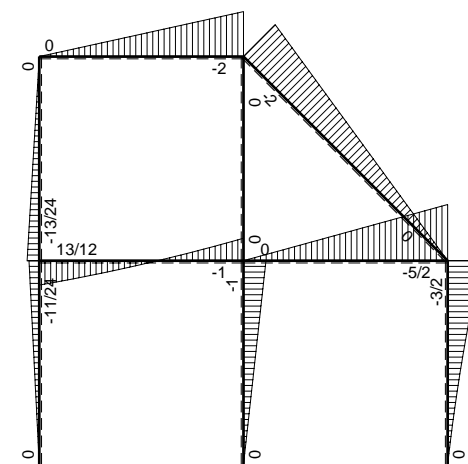

⊕ ⊖ F_b

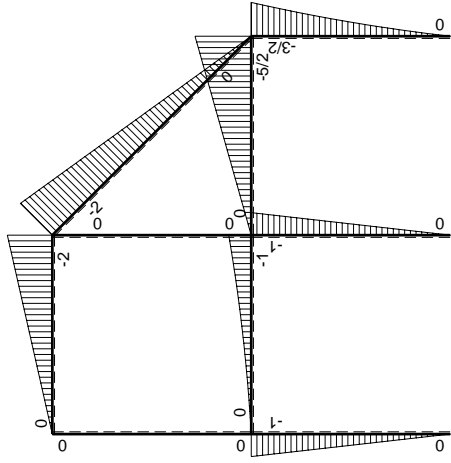
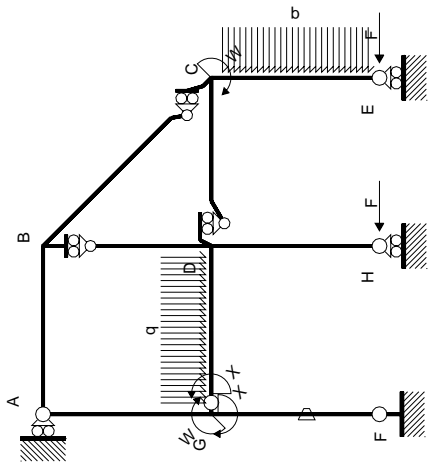

Schema di calcolo iperstatico

M_0 flessione da carichi assegnati

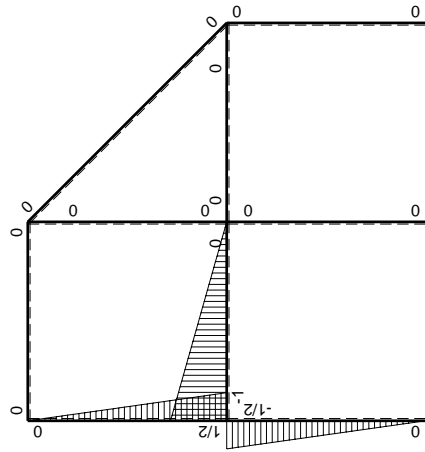

M_x flessione da iperstatica $X=1$

Quadro contributi PLV per iperstatica $X=W_{GD}$

→	$M_x(x)$	$M_o(x)$	θ	$M_x M_o$	$M_x \theta$	$M_x M_x$	$\int M_x(M_o/EJ+\theta)dx$	$\int X M_x M_x/EJ dx$	
AB b	0	-2Fx	0	0	0	0	0+0	0	
BA b	0	2Fb-2Fx	0	0	0	0	0	0	
BC $\sqrt{2}b$	0	-2Fb+ $\sqrt{2}Fx$	0	0	0	0	0	0	
BD b	0	0	0	0	0	0	0+0	0	
DB b	0	0	0	0	0	0	0	0	
DC b	0	-5/2Fx	0	0	0	0	0+0	0	
CD b	0	5/2Fb-5/2Fx	0	0	0	0	0	0	
CE b	0	-3/2Fb+2Fx-1/2qx ²	0	0	0	0	0+0	0	
EC b	0	Fx+1/2qx ²	0	0	0	0	0	0	
FG b	-1/2x/b	-Fx	-Fb/EJ	1/2Fx ² /b	1/2Fx/EJ	1/4x ² /b ²	(1/6+1/4)Fb ² /EJ	1/12Xb/EJ	
GF b	1/2-1/2x/b	Fb-Fx	Fb/EJ	1/2Fb-Fx+1/2Fx ² /b	1/2Fb/EJ-1/2Fx/EJ	1/4-1/2x/b+1/4x ² /b ²			
GD b	-1+x/b	-1/2Fx-1/2qx ²	0	1/2Fx-1/2qx ³ /b	0	1-2x/b+x ² /b ²	(1/8+0)Fb ² /EJ	1/3Xb/EJ	
DG b	x/b	Fb-3/2Fx+1/2qx ²	0	Fx-3/2Fx ² /b+1/2qx ³ /b	0	x ² /b ²			
DH b	0	-Fb+Fx	0	0	0	0	0+0	0	
HD b	0	Fx	0	0	0	0	0	0	
GA b	1/2-1/2x/b	0	0	0	0	1/4-1/2x/b+1/4x ² /b ²	0+0	1/12Xb/EJ	
AG b	-1/2x/b	0	0	0	0	1/4x ² /b ²			
	totali							13/24Fb ² /EJ	1/2Xb/EJ
	iperstatica $X=W_{GD}$							-13/12Fb	

Sviluppi di calcolo iperstatica

$$L_{FG}^{xx} = \int_0^b (1/4 x^2/b^2) 1/EJ dx = [1/12 x^3/b^2]_0^b 1/EJ$$

$$= (1/12 b) 1/EJ = 1/12 b/EJ$$

$$L_{GF}^{xx} = \int_0^b (1/4 - 1/2 x/b + 1/4 x^2/b^2) 1/EJ dx = [1/4 x - 1/4 x^2/b + 1/12 x^3/b^2]_0^b 1/EJ$$

$$= (1/4 b - 1/4 b + 1/12 b) 1/EJ = 1/12 b/EJ$$

$$L_{GD}^{xx} = \int_0^b (1 - 2 x/b + x^2/b^2) 1/EJ dx = [x - x^2/b + 1/3 x^3/b^2]_0^b 1/EJ$$

$$= (b - b + 1/3 b) 1/EJ = 1/3 b/EJ$$

$$L_{DG}^{xx} = \int_0^b (x^2/b^2) 1/EJ dx = [1/3 x^3/b^2]_0^b 1/EJ$$

$$= (1/3 b) 1/EJ = 1/3 b/EJ$$

$$L_{GA}^{xx} = \int_0^b (1/4 - 1/2 x/b + 1/4 x^2/b^2) 1/EJ dx = [1/4 x - 1/4 x^2/b + 1/12 x^3/b^2]_0^b 1/EJ$$

$$= (1/4 b - 1/4 b + 1/12 b) 1/EJ = 1/12 b/EJ$$

$$L_{AG}^{xx} = \int_0^b (1/4 x^2/b^2) 1/EJ dx = [1/12 x^3/b^2]_0^b 1/EJ$$

$$= (1/12 b) 1/EJ = 1/12 b/EJ$$

$$L_{FG}^{xo} = \int_0^b (1/2 x^2/b^2) Fb 1/EJ dx + \int_0^b (1/2 x/b) \theta dx = [1/6 x^3/b^2]_0^b Fb 1/EJ + [1/4 x^2/b]_0^b \theta$$

$$= (1/6 b) Fb 1/EJ + (1/4 b) \theta = 5/12 Fb^2/EJ$$

$$L_{GF}^{xo} = \int_0^b (1/2 - x/b + 1/2 x^2/b^2) Fb 1/EJ dx + \int_0^b (-1/2 + 1/2 x/b) \theta dx$$

$$= [1/2 x - 1/2 x^2/b + 1/6 x^3/b^2]_0^b Fb 1/EJ + [-1/2 x + 1/4 x^2/b]_0^b \theta$$

$$= (1/2 b - 1/2 b + 1/6 b) Fb 1/EJ + (-1/2 b + 1/4 b) \theta = 5/12 Fb^2/EJ$$

$$L_{GD}^{xo} = \int_0^b (1/2 x/b - 1/2 x^3/b^3) Fb 1/EJ dx = [1/4 x^2/b - 1/8 x^4/b^3]_0^b Fb 1/EJ$$

$$= (1/4 b - 1/8 b) Fb 1/EJ = 1/8 Fb^2/EJ$$

$$L_{DG}^{xo} = \int_0^b (x/b - 3/2 x^2/b^2 + 1/2 x^3/b^3) Fb 1/EJ dx = [1/2 x^2/b - 1/2 x^3/b^2 + 1/8 x^4/b^3]_0^b Fb 1/EJ$$

$$= (1/2 b - 1/2 b + 1/8 b) Fb 1/EJ = 1/8 Fb^2/EJ$$

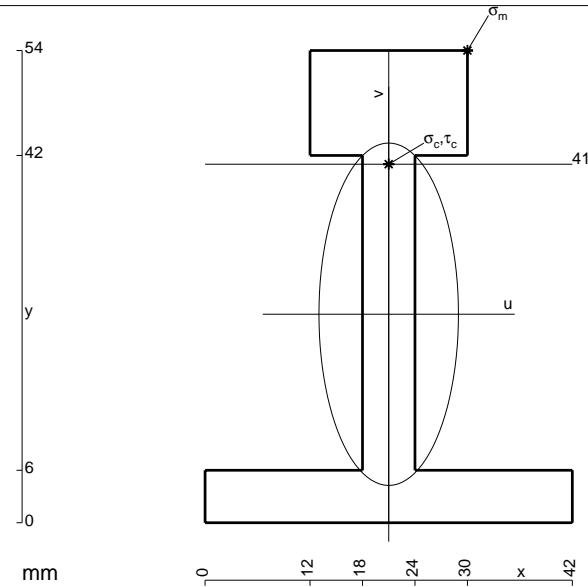

- A = 684. mm²
- J_u = 262207. mm⁴
- J_v = 43524. mm⁴
- y_g = 23.84 mm
- T_y = -3400. N
- M_x = -1734000. Nmm
- x_m = 30. mm
- y_m = 54. mm
- u_m = 9. mm
- v_m = 30.16 mm
- σ_m = -Mv/J_u = 199.4 N/mm²
- x_c = 21. mm
- y_c = 41. mm
- v_c = 17.16 mm
- σ_c = -Mv/J_u = 113.5 N/mm²
- τ_c = 11.51 N/mm²
- σ_q = √σ²+3τ² = 115.2 N/mm²
- S = 5324. mm³

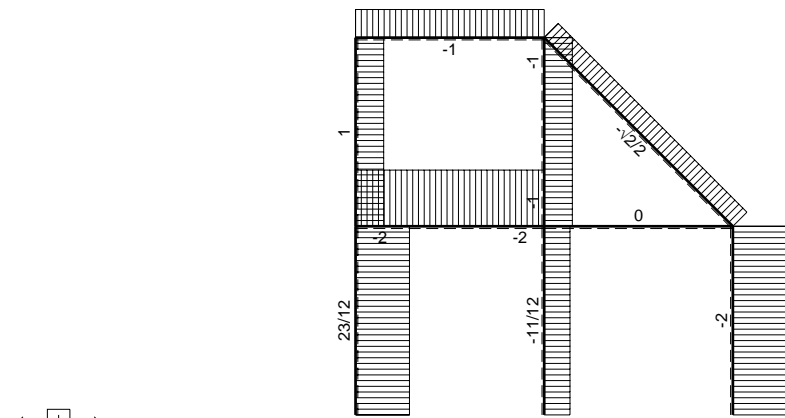
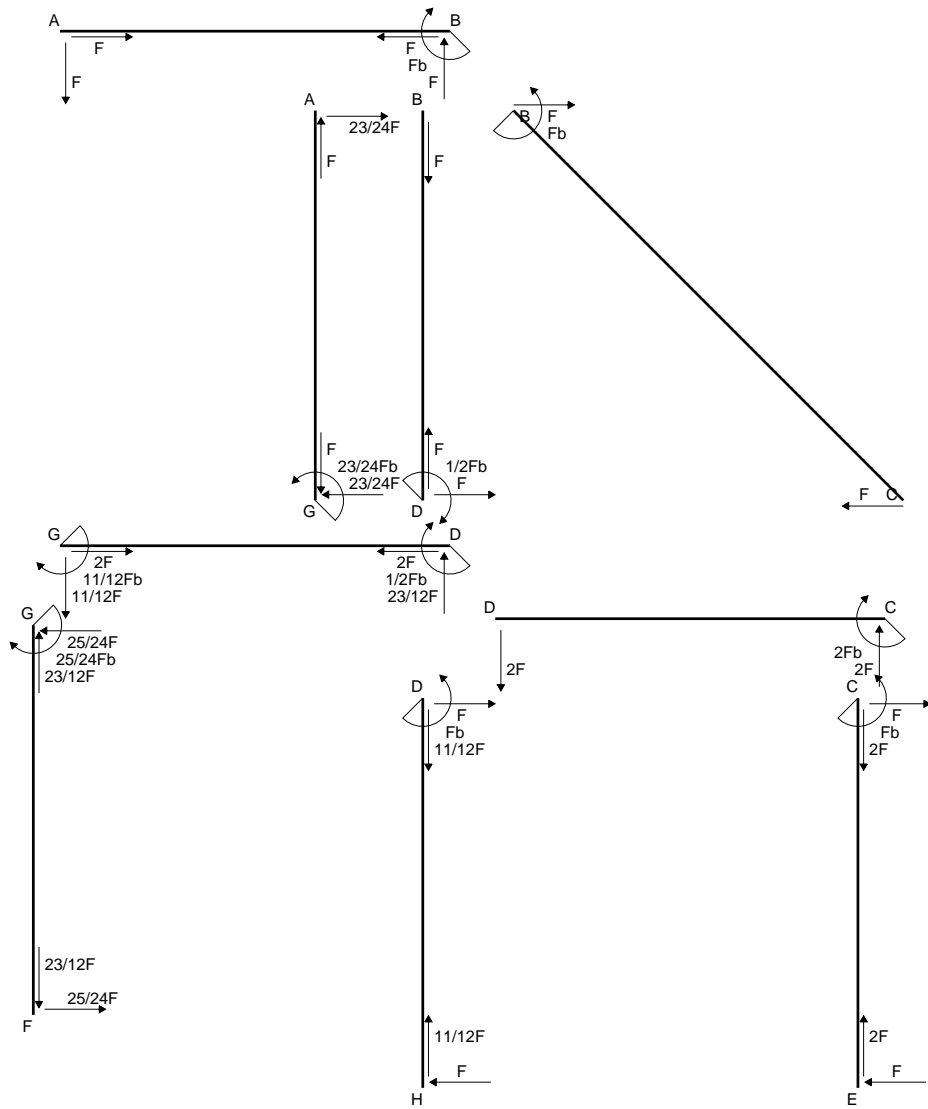

← ⊕ → F

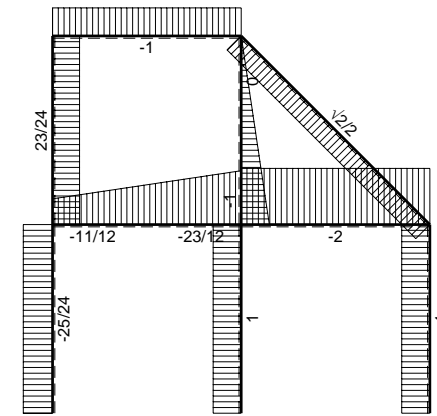

⊕ ↓ F

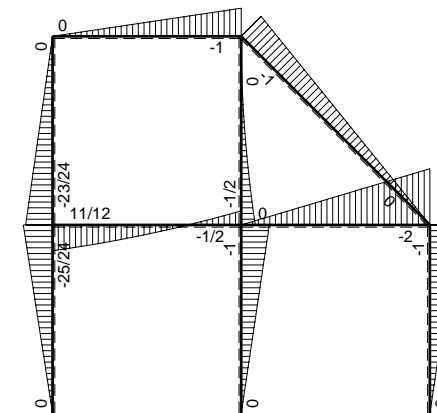

⊕ ↺ F_b

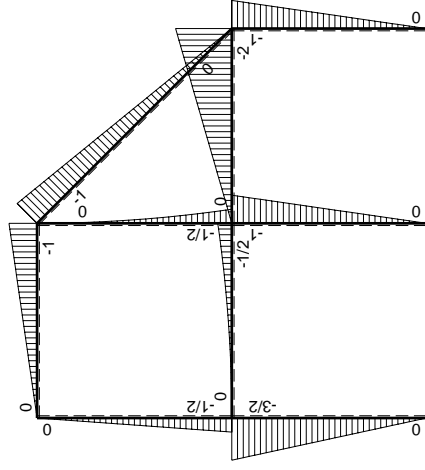
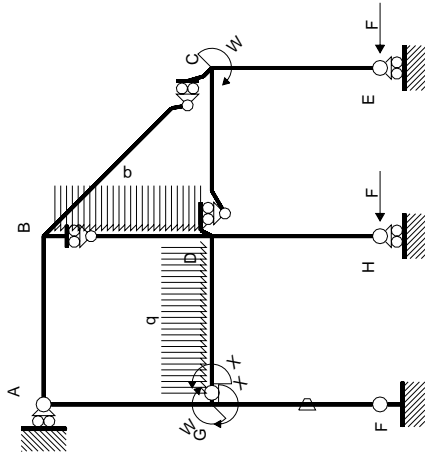

Schema di calcolo iperstatico

M_0 flessione da carichi assegnati

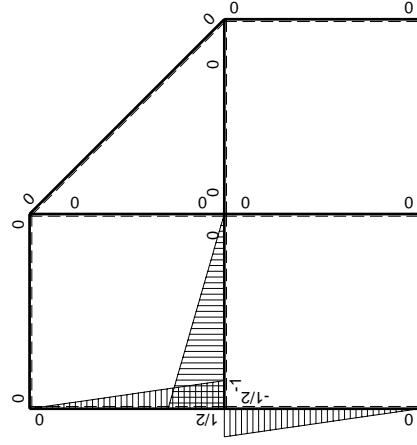

M_x flessione da iperstatica $X=1$

Quadro contributi PLV per iperstatica $X=W_{GD}$

→	$M_x(x)$	$M_o(x)$	θ	$M_x M_o$	$M_x \theta$	$M_x M_x$	$\int M_x(M_o/EJ+\theta)dx$	$\int X M_x M_x/EJ dx$
AB b	0	-Fx	0	0	0	0	0+0	0
BA b	0	Fb-Fx	0	0	0	0		
BC $\sqrt{2}b$	0	-Fb+ $\sqrt{2}/2Fx$	0	0	0	0	0	0
BD b	0	-1/2qx ²	0	0	0	0	0+0	0
DB b	0	1/2Fb-Fx+1/2qx ²	0	0	0	0		
DC b	0	-2Fx	0	0	0	0	0+0	0
CD b	0	2Fb-2Fx	0	0	0	0		
CE b	0	-Fb+Fx	0	0	0	0	0+0	0
EC b	0	Fx	0	0	0	0		
FG b	-1/2x/b	-3/2Fx	-Fb/EJ	3/4Fx ² /b	1/2Fx/EJ	1/4x ² /b ²	(1/4+1/4)Fb ² /EJ	1/12Xb/EJ
GF b	1/2-1/2x/b	3/2Fb-3/2Fx	Fb/EJ	3/4Fb-3/2Fx+3/4Fx ² /b	1/2Fb/EJ-1/2Fx/EJ	1/4-1/2x/b+1/4x ² /b ²		
GD b	-1+x/b	-1/2qx ²	0	1/2Fx ² /b-1/2qx ³ /b	0	1-2x/b+x ² /b ²	(1/24+0)Fb ² /EJ	1/3Xb/EJ
DG b	x/b	1/2Fb-Fx+1/2qx ²	0	1/2Fx-Fx ² /b+1/2qx ³ /b	0	x ² /b ²		
DH b	0	-Fb+Fx	0	0	0	0	0+0	0
HD b	0	Fx	0	0	0	0		
GA b	1/2-1/2x/b	-1/2Fb+1/2Fx	0	-1/4Fb+1/2Fx-1/4Fx ² /b	0	1/4-1/2x/b+1/4x ² /b ²	(-1/12+0)Fb ² /EJ	1/12Xb/EJ
AG b	-1/2x/b	1/2Fx	0	-1/4Fx ² /b	0	1/4x ² /b ²		
	totali						11/24Fb ² /EJ	1/2Xb/EJ
	iperstatica $X=W_{GD}$						-11/12Fb	

Sviluppi di calcolo iperstatica

$$L_{FG}^{xx} = \int_0^b (1/4 x^2/b^2) 1/EJ dx = [1/12 x^3/b^2]_0^b 1/EJ$$

$$= (1/12 b) 1/EJ = 1/12 b/EJ$$

$$L_{GF}^{xx} = \int_0^b (1/4 - 1/2 x/b + 1/4 x^2/b^2) 1/EJ dx = [1/4 x - 1/4 x^2/b + 1/12 x^3/b^2]_0^b 1/EJ$$

$$= (1/4 b - 1/4 b + 1/12 b) 1/EJ = 1/12 b/EJ$$

$$L_{GD}^{xx} = \int_0^b (1 - 2 x/b + x^2/b^2) 1/EJ dx = [x - x^2/b + 1/3 x^3/b^2]_0^b 1/EJ$$

$$= (b - b + 1/3 b) 1/EJ = 1/3 b/EJ$$

$$L_{DG}^{xx} = \int_0^b (x^2/b^2) 1/EJ dx = [1/3 x^3/b^2]_0^b 1/EJ$$

$$= (1/3 b) 1/EJ = 1/3 b/EJ$$

$$L_{GA}^{xx} = \int_0^b (1/4 - 1/2 x/b + 1/4 x^2/b^2) 1/EJ dx = [1/4 x - 1/4 x^2/b + 1/12 x^3/b^2]_0^b 1/EJ$$

$$= (1/4 b - 1/4 b + 1/12 b) 1/EJ = 1/12 b/EJ$$

$$L_{AG}^{xx} = \int_0^b (1/4 x^2/b^2) 1/EJ dx = [1/12 x^3/b^2]_0^b 1/EJ$$

$$= (1/12 b) 1/EJ = 1/12 b/EJ$$

$$L_{FG}^{xo} = \int_0^b (3/4 x^2/b^2) Fb 1/EJ dx + \int_0^b (1/2 x/b) \theta dx = [1/4 x^3/b^2]_0^b Fb 1/EJ + [1/4 x^2/b]_0^b \theta$$

$$= (1/4 b) Fb 1/EJ + (1/4 b) \theta = 1/2 Fb^2/EJ$$

$$L_{GF}^{xo} = \int_0^b (3/4 - 3/2 x/b + 3/4 x^2/b^2) Fb 1/EJ dx + \int_0^b (-1/2 + 1/2 x/b) \theta dx$$

$$= [3/4 x - 3/4 x^2/b + 1/4 x^3/b^2]_0^b Fb 1/EJ + [-1/2 x + 1/4 x^2/b]_0^b \theta$$

$$= (3/4 b - 3/4 b + 1/4 b) Fb 1/EJ + (-1/2 b + 1/4 b) \theta = 1/2 Fb^2/EJ$$

$$L_{GD}^{xo} = \int_0^b (1/2 x^2/b^2 - 1/2 x^3/b^3) Fb 1/EJ dx = [1/6 x^3/b^2 - 1/8 x^4/b^3]_0^b Fb 1/EJ$$

$$= (1/6 b - 1/8 b) Fb 1/EJ = 1/24 Fb^2/EJ$$

$$L_{DG}^{xo} = \int_0^b (1/2 x/b - x^2/b^2 + 1/2 x^3/b^3) Fb 1/EJ dx = [1/4 x^2/b - 1/3 x^3/b^2 + 1/8 x^4/b^3]_0^b Fb 1/EJ$$

$$= (1/4 b - 1/3 b + 1/8 b) Fb 1/EJ = 1/24 Fb^2/EJ$$

$$L_{GA}^{xo} = \int_0^b (-1/4 + 1/2 x/b - 1/4 x^2/b^2) Fb 1/EJ dx = [-1/4 x + 1/4 x^2/b - 1/12 x^3/b^2]_0^b Fb 1/EJ$$

$$= (-1/4 b + 1/4 b - 1/12 b) Fb 1/EJ = -1/12 Fb^2/EJ$$

$$L_{AG}^{xo} = \int_0^b (-1/4 x^2/b^2) Fb 1/EJ dx = [-1/12 x^3/b^2]_0^b Fb 1/EJ$$

$$= (-1/12 b) Fb 1/EJ = -1/12 Fb^2/EJ$$

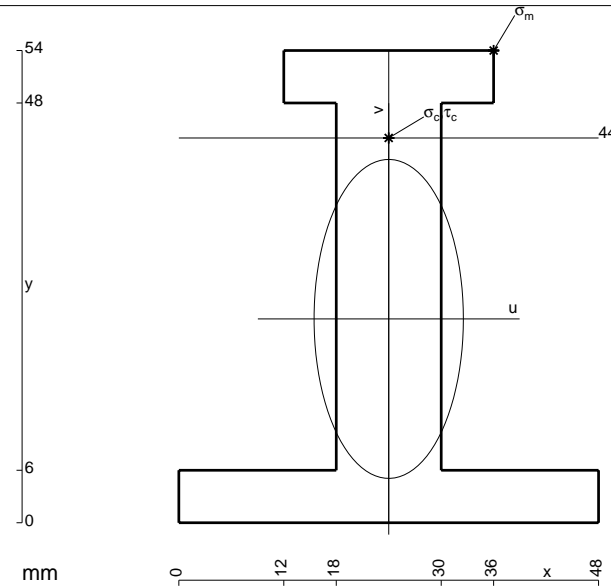

$$A = 936. \text{ mm}^2$$

$$J_u = 311455. \text{ mm}^4$$

$$J_v = 68256. \text{ mm}^4$$

$$y_g = 23.31 \text{ mm}$$

$$T_y = -3800. \text{ N}$$

$$M_x = -2128000. \text{ Nmm}$$

$$x_m = 36. \text{ mm}$$

$$y_m = 54. \text{ mm}$$

$$u_m = 12. \text{ mm}$$

$$v_m = 30.69 \text{ mm}$$

$$\sigma_m = -Mv/J_u = 209.7 \text{ N/mm}^2$$

$$x_c = 24. \text{ mm}$$

$$y_c = 44. \text{ mm}$$

$$v_c = 20.69 \text{ mm}$$

$$\sigma_c = -Mv/J_u = 141.4 \text{ N/mm}^2$$

$$\tau_c = 5.162 \text{ N/mm}^2$$

$$\sigma_q = \sqrt{\sigma^2 + 3\tau^2} = 141.7 \text{ N/mm}^2$$

$$S = 5077. \text{ mm}^3$$

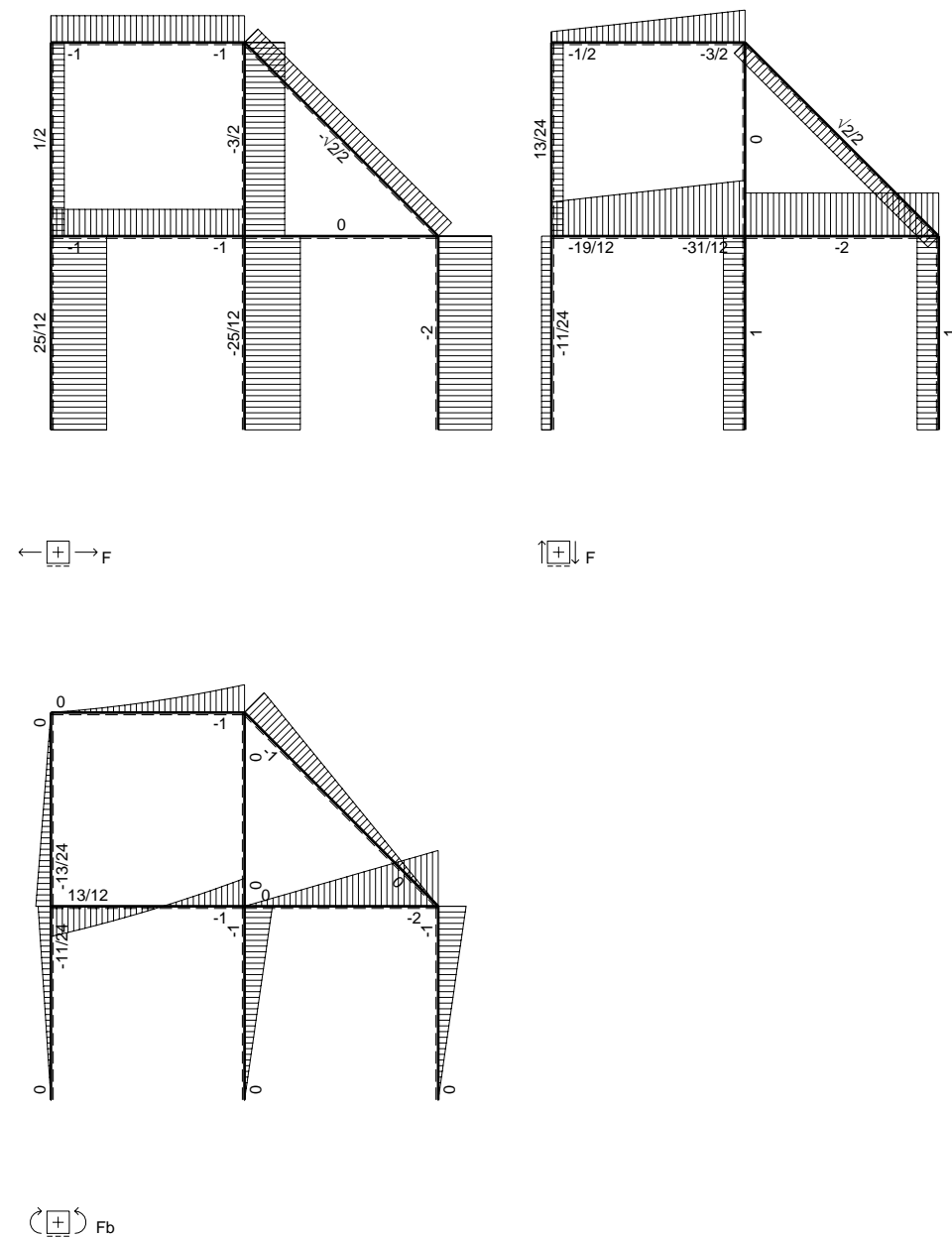
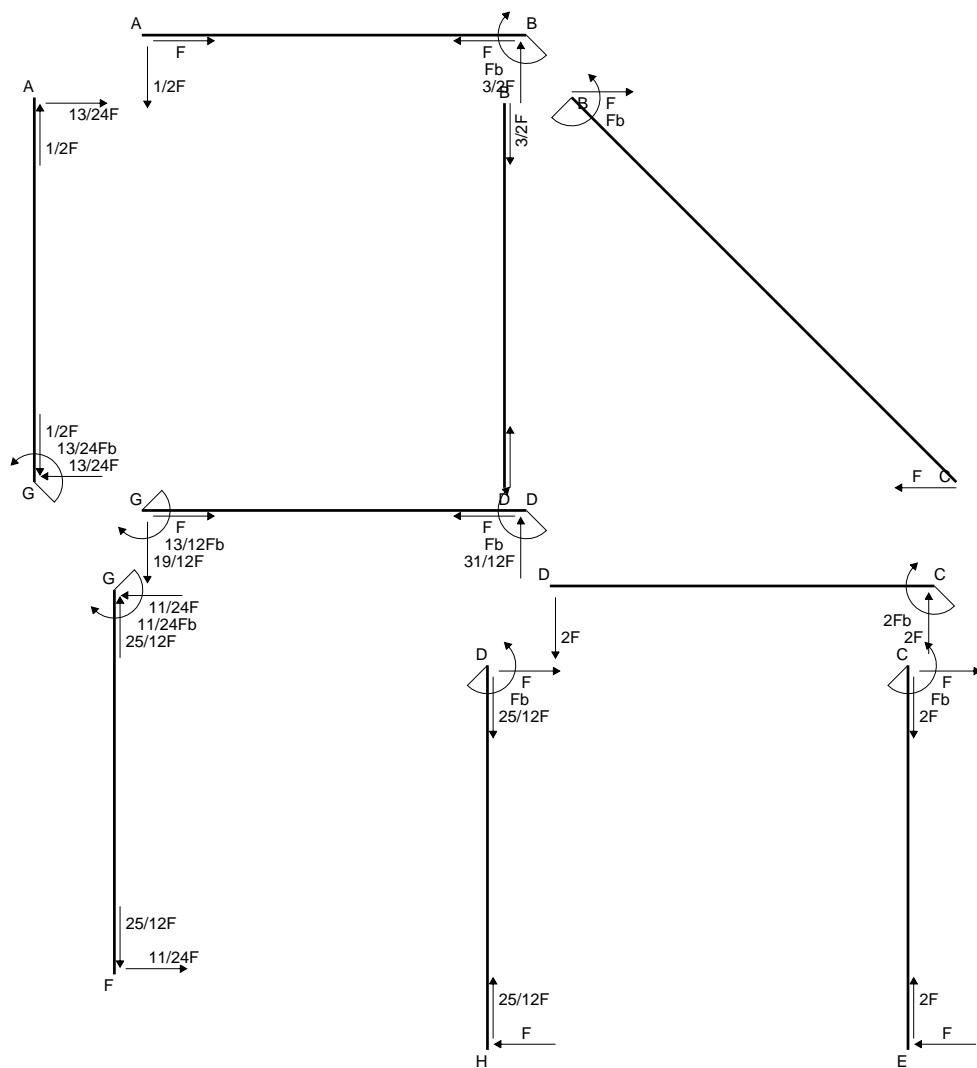

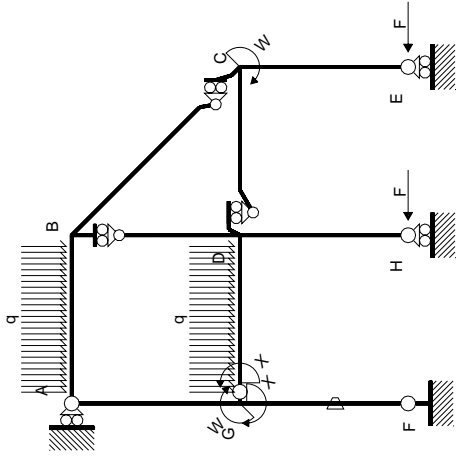

Schema di calcolo iperstatico

M_0 flessione da carichi assegnati

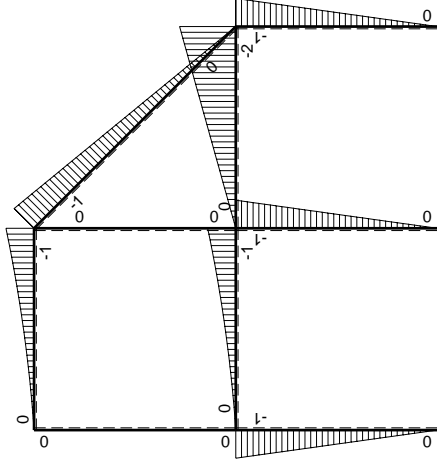
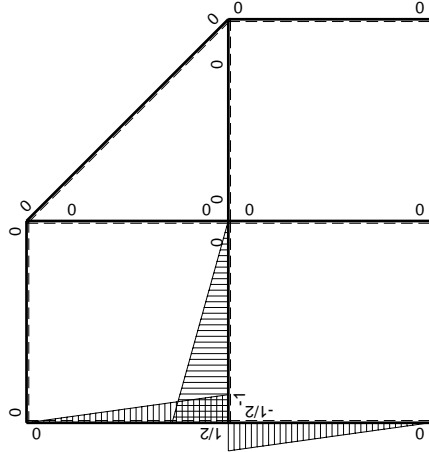

Quadro contributi PLV per iperstatica $X=W_{GD}$

→	$M_x(x)$	$M_o(x)$	θ	$M_x M_o$	$M_x \theta$	$M_x M_x$	$\int M_x(M_o/EJ+\theta)dx$	$\int X M_x M_x/EJdx$	
AB b	0	$-1/2Fx-1/2qx^2$	0	0	0	0	0+0	0	
BA b	0	$Fb-3/2Fx+1/2qx^2$	0	0	0	0	0	0	
BC $\sqrt{2}b$	0	$-Fb+\sqrt{2}/2Fx$	0	0	0	0	0	0	
BD b	0	0	0	0	0	0	0+0	0	
DB b	0	0	0	0	0	0	0	0	
DC b	0	$-2Fx$	0	0	0	0	0+0	0	
CD b	0	$2Fb-2Fx$	0	0	0	0	0	0	
CE b	0	$-Fb+Fx$	0	0	0	0	0+0	0	
EC b	0	Fx	0	0	0	0	0	0	
FG b	$-1/2x/b$	$-Fx$	$-Fb/EJ$	$1/2Fx^2/b$	$1/2Fx/EJ$	$1/4x^2/b^2$	$(1/6+1/4)Fb^2/EJ$	$1/12Xb/EJ$	
GF b	$1/2-1/2x/b$	$Fb-Fx$	Fb/EJ	$1/2Fb-Fx+1/2Fx^2/b$	$1/2Fb/EJ-1/2Fx/EJ$	$1/4-1/2x/b+1/4x^2/b^2$			
GD b	$-1+x/b$	$-1/2Fx-1/2qx^2$	0	$1/2Fx-1/2qx^3/b$	0	$1-2x/b+x^2/b^2$	$(1/8+0)Fb^2/EJ$	$1/3Xb/EJ$	
DG b	x/b	$Fb-3/2Fx+1/2qx^2$	0	$Fx-3/2Fx^2/b+1/2qx^3/b$	0	x^2/b^2			
DH b	0	$-Fb+Fx$	0	0	0	0	0+0	0	
HD b	0	Fx	0	0	0	0	0	0	
GA b	$1/2-1/2x/b$	0	0	0	0	$1/4-1/2x/b+1/4x^2/b^2$	0+0	$1/12Xb/EJ$	
AG b	$-1/2x/b$	0	0	0	0	$1/4x^2/b^2$			
	totali							$13/24Fb^2/EJ$	$1/2Xb/EJ$
	iperstatica $X=W_{GD}$							$-13/12Fb$	

Sviluppi di calcolo iperstatica

$$L_{FG}^{xx} = \int_0^b (1/4 x^2/b^2) 1/EJ dx = [1/12 x^3/b^2]_0^b 1/EJ$$

$$= (1/12 b) 1/EJ = 1/12 b/EJ$$

$$L_{GF}^{xx} = \int_0^b (1/4 - 1/2 x/b + 1/4 x^2/b^2) 1/EJ dx = [1/4 x - 1/4 x^2/b + 1/12 x^3/b^2]_0^b 1/EJ$$

$$= (1/4 b - 1/4 b + 1/12 b) 1/EJ = 1/12 b/EJ$$

$$L_{GD}^{xx} = \int_0^b (1 - 2 x/b + x^2/b^2) 1/EJ dx = [x - x^2/b + 1/3 x^3/b^2]_0^b 1/EJ$$

$$= (b - b + 1/3 b) 1/EJ = 1/3 b/EJ$$

$$L_{DG}^{xx} = \int_0^b (x^2/b^2) 1/EJ dx = [1/3 x^3/b^2]_0^b 1/EJ$$

$$= (1/3 b) 1/EJ = 1/3 b/EJ$$

$$L_{GA}^{xx} = \int_0^b (1/4 - 1/2 x/b + 1/4 x^2/b^2) 1/EJ dx = [1/4 x - 1/4 x^2/b + 1/12 x^3/b^2]_0^b 1/EJ$$

$$= (1/4 b - 1/4 b + 1/12 b) 1/EJ = 1/12 b/EJ$$

$$L_{AG}^{xx} = \int_0^b (1/4 x^2/b^2) 1/EJ dx = [1/12 x^3/b^2]_0^b 1/EJ$$

$$= (1/12 b) 1/EJ = 1/12 b/EJ$$

$$L_{FG}^{x_0} = \int_0^b (1/2 x^2/b^2) Fb 1/EJ dx + \int_0^b (1/2 x/b) \theta dx = [1/6 x^3/b^2]_0^b Fb 1/EJ + [1/4 x^2/b]_0^b \theta$$

$$= (1/6 b) Fb 1/EJ + (1/4 b) \theta = 5/12 Fb^2/EJ$$

$$L_{GF}^{x_0} = \int_0^b (1/2 - x/b + 1/2 x^2/b^2) Fb 1/EJ dx + \int_0^b (-1/2 + 1/2 x/b) \theta dx$$

$$= [1/2 x - 1/2 x^2/b + 1/6 x^3/b^2]_0^b Fb 1/EJ + [-1/2 x + 1/4 x^2/b]_0^b \theta$$

$$= (1/2 b - 1/2 b + 1/6 b) Fb 1/EJ + (-1/2 b + 1/4 b) \theta = 5/12 Fb^2/EJ$$

$$L_{GD}^{x_0} = \int_0^b (1/2 x/b - 1/2 x^3/b^3) Fb 1/EJ dx = [1/4 x^2/b - 1/8 x^4/b^3]_0^b Fb 1/EJ$$

$$= (1/4 b - 1/8 b) Fb 1/EJ = 1/8 Fb^2/EJ$$

$$L_{DG}^{x_0} = \int_0^b (x/b - 3/2 x^2/b^2 + 1/2 x^3/b^3) Fb 1/EJ dx = [1/2 x^2/b - 1/2 x^3/b^2 + 1/8 x^4/b^3]_0^b Fb 1/EJ$$

$$= (1/2 b - 1/2 b + 1/8 b) Fb 1/EJ = 1/8 Fb^2/EJ$$

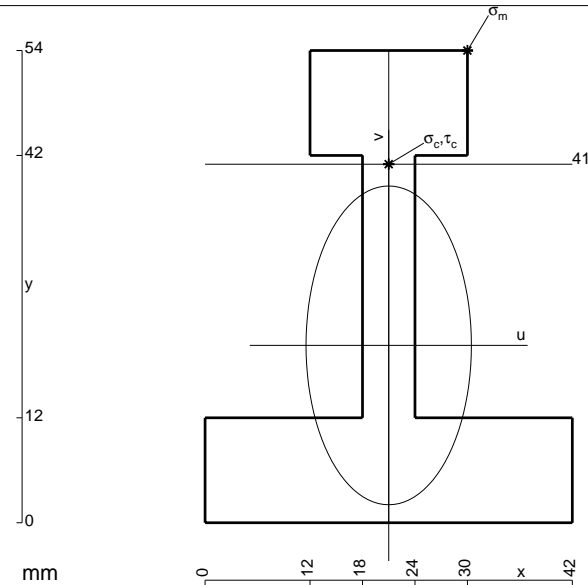

$$A = 900. \text{ mm}^2$$

$$J_u = 299017. \text{ mm}^4$$

$$J_v = 80460. \text{ mm}^4$$

$$y_g = 20.28 \text{ mm}$$

$$T_y = -3180. \text{ N}$$

$$M_x = -1939800. \text{ Nmm}$$

$$x_m = 30. \text{ mm}$$

$$y_m = 54. \text{ mm}$$

$$u_m = 9. \text{ mm}$$

$$v_m = 33.72 \text{ mm}$$

$$\sigma_m = -Mv/J_u = 218.8 \text{ N/mm}^2$$

$$x_c = 21. \text{ mm}$$

$$y_c = 41. \text{ mm}$$

$$v_c = 20.72 \text{ mm}$$

$$\sigma_c = -Mv/J_u = 134.4 \text{ N/mm}^2$$

$$\tau_c = 10.84 \text{ N/mm}^2$$

$$\sigma_q = \sqrt{\sigma^2 + 3\tau^2} = 135.7 \text{ N/mm}^2$$

$$S = 6115. \text{ mm}^3$$

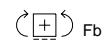
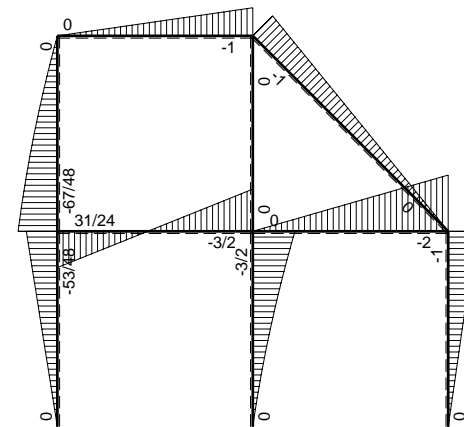
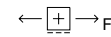
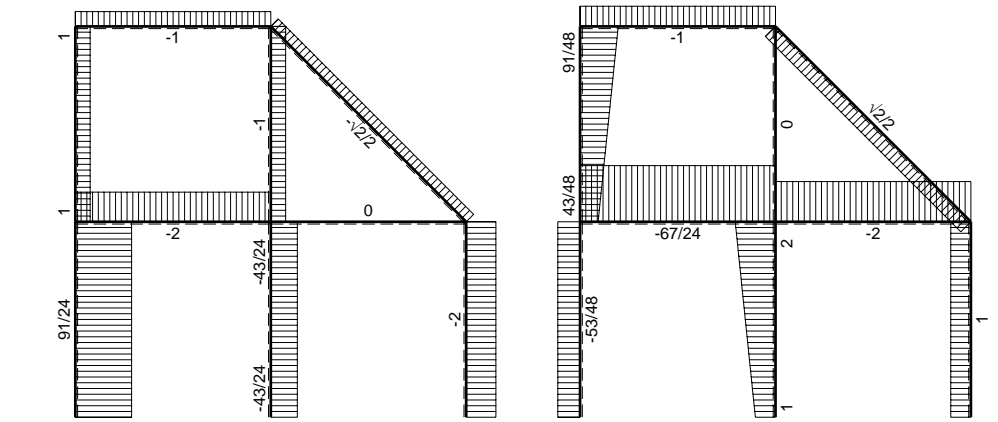
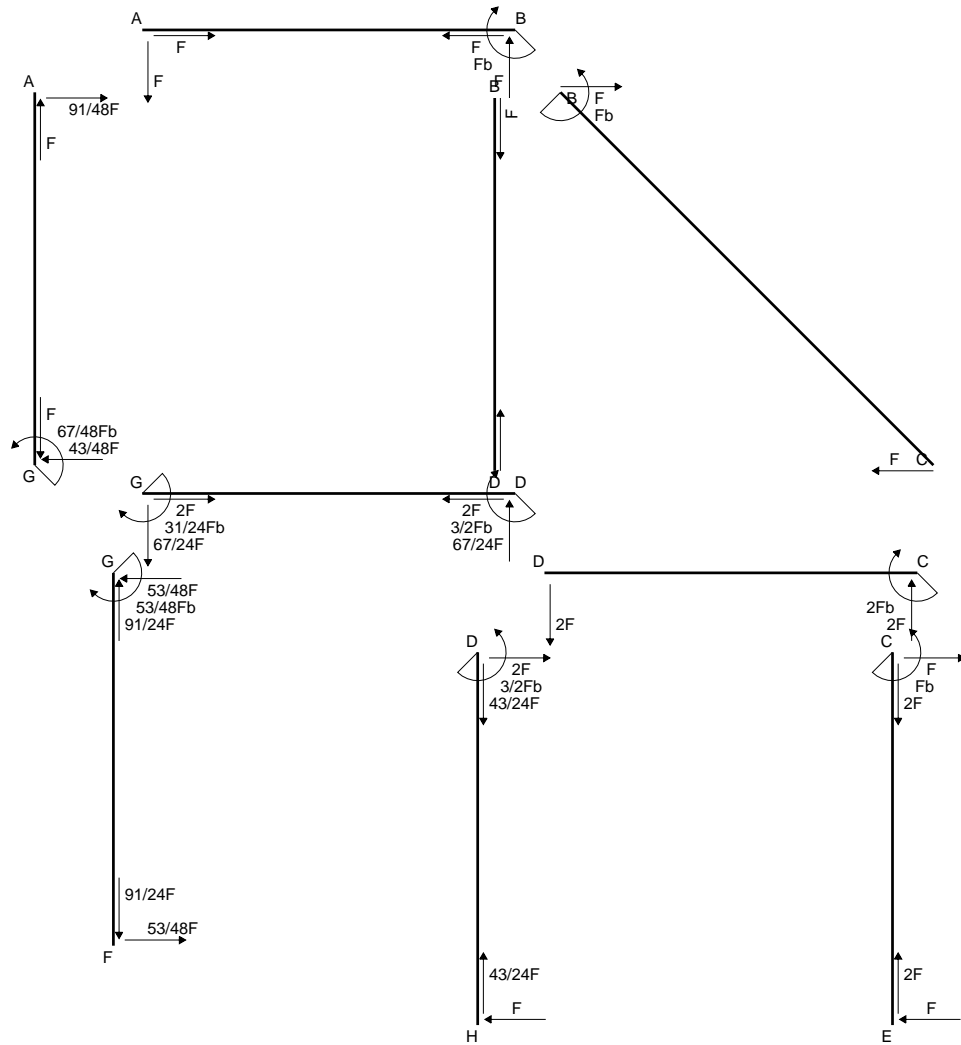

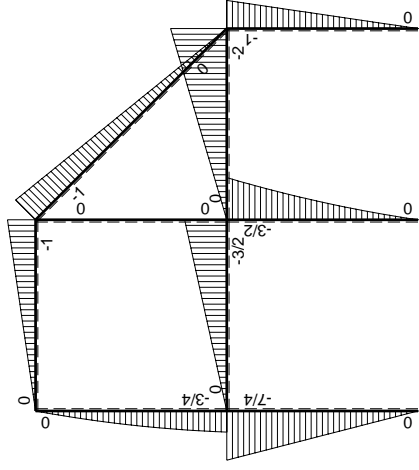
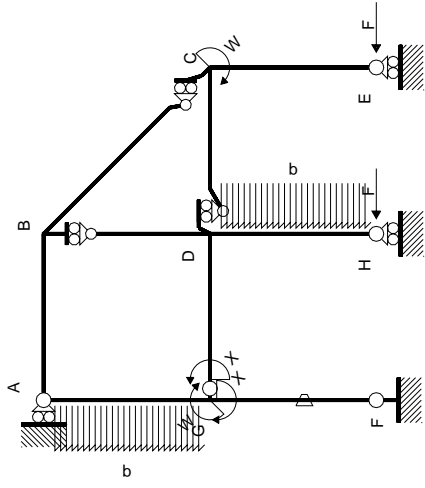

Schema di calcolo iperstatico

M_0 flessione da carichi assegnati

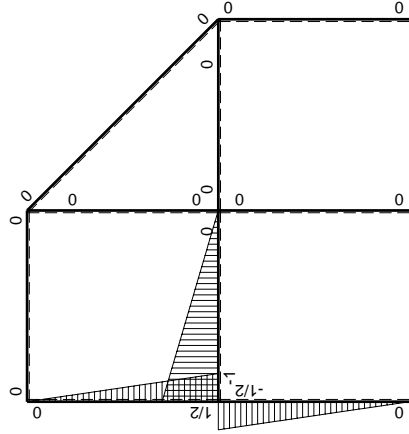

M_x flessione da iperstatica $X=1$

Quadro contributi PLV per iperstatica $X=W_{GD}$

→	$M_x(x)$	$M_o(x)$	θ	$M_x M_o$	$M_x \theta$	$M_x M_x$	$\int M_x(M_o/EJ+\theta)dx$	$\int X M_x M_x/EJ dx$
AB b	0	-Fx	0	0	0	0	0+0	0
BA b	0	Fb-Fx	0	0	0	0	0	0
BC $\sqrt{2}b$	0	-Fb+ $\sqrt{2}/2Fx$	0	0	0	0	0	0
BD b	0	0	0	0	0	0	0+0	0
DB b	0	0	0	0	0	0	0	0
DC b	0	-2Fx	0	0	0	0	0+0	0
CD b	0	2Fb-2Fx	0	0	0	0	0	0
CE b	0	-Fb+Fx	0	0	0	0	0+0	0
EC b	0	Fx	0	0	0	0	0	0
FG b	-1/2x/b	-7/4Fx	-Fb/EJ	7/8Fx ² /b	1/2Fx/EJ	1/4x ² /b ²	(7/24+1/4)Fb ² /EJ	1/12Xb/EJ
GF b	1/2-1/2x/b	7/4Fb-7/4Fx	Fb/EJ	7/8Fb-7/4Fx+7/8Fx ² /b	1/2Fb/EJ-1/2Fx/EJ	1/4-1/2x/b+1/4x ² /b ²		
GD b	-1+x/b	-3/2Fx	0	3/2Fx-3/2Fx ² /b	0	1-2x/b+x ² /b ²	(1/4+0)Fb ² /EJ	1/3Xb/EJ
DG b	x/b	3/2Fb-3/2Fx	0	3/2Fx-3/2Fx ² /b	0	x ² /b ²		
DH b	0	-3/2Fb+2Fx-1/2qx ²	0	0	0	0	0+0	0
HD b	0	Fx+1/2qx ²	0	0	0	0		
GA b	1/2-1/2x/b	-3/4Fb+1/4Fx+1/2qx ²	0	-3/8Fb+1/2Fx+1/8Fx ² /b-1/4qx ³ /b	0	1/4-1/2x/b+1/4x ² /b ²	(-7/48+0)Fb ² /EJ	1/12Xb/EJ
AG b	-1/2x/b	5/4Fx-1/2qx ²	0	-5/8Fx ² /b+1/4qx ³ /b	0	1/4x ² /b ²		
	totali						31/48Fb ² /EJ	1/2Xb/EJ
	iperstatica $X=W_{GD}$						-31/24Fb	

Sviluppi di calcolo iperstatica

$$L_{FG}^{xx} = \int_0^b (1/4 x^2/b^2) 1/EJ dx = [1/12 x^3/b^2]_0^b 1/EJ$$

$$= (1/12 b) 1/EJ = 1/12 b/EJ$$

$$L_{GF}^{xx} = \int_0^b (1/4 - 1/2 x/b + 1/4 x^2/b^2) 1/EJ dx = [1/4 x - 1/4 x^2/b + 1/12 x^3/b^2]_0^b 1/EJ$$

$$= (1/4 b - 1/4 b + 1/12 b) 1/EJ = 1/12 b/EJ$$

$$L_{GD}^{xx} = \int_0^b (1 - 2 x/b + x^2/b^2) 1/EJ dx = [x - x^2/b + 1/3 x^3/b^2]_0^b 1/EJ$$

$$= (b - b + 1/3 b) 1/EJ = 1/3 b/EJ$$

$$L_{DG}^{xx} = \int_0^b (x^2/b^2) 1/EJ dx = [1/3 x^3/b^2]_0^b 1/EJ$$

$$= (1/3 b) 1/EJ = 1/3 b/EJ$$

$$L_{GA}^{xx} = \int_0^b (1/4 - 1/2 x/b + 1/4 x^2/b^2) 1/EJ dx = [1/4 x - 1/4 x^2/b + 1/12 x^3/b^2]_0^b 1/EJ$$

$$= (1/4 b - 1/4 b + 1/12 b) 1/EJ = 1/12 b/EJ$$

$$L_{AG}^{xx} = \int_0^b (1/4 x^2/b^2) 1/EJ dx = [1/12 x^3/b^2]_0^b 1/EJ$$

$$= (1/12 b) 1/EJ = 1/12 b/EJ$$

$$L_{FG}^{xo} = \int_0^b (7/8 x^2/b^2) Fb 1/EJ dx + \int_0^b (1/2 x/b) \theta dx = [7/24 x^3/b^2]_0^b Fb 1/EJ + [1/4 x^2/b]_0^b \theta$$

$$= (7/24 b) Fb 1/EJ + (1/4 b) \theta = 13/24 Fb^2/EJ$$

$$L_{GF}^{xo} = \int_0^b (7/8 - 7/4 x/b + 7/8 x^2/b^2) Fb 1/EJ dx + \int_0^b (-1/2 + 1/2 x/b) \theta dx$$

$$= [7/8 x - 7/8 x^2/b + 7/24 x^3/b^2]_0^b Fb 1/EJ + [-1/2 x + 1/4 x^2/b]_0^b \theta$$

$$= (7/8 b - 7/8 b + 7/24 b) Fb 1/EJ + (-1/2 b + 1/4 b) \theta = 13/24 Fb^2/EJ$$

$$L_{GD}^{xo} = \int_0^b (3/2 x/b - 3/2 x^2/b^2) Fb 1/EJ dx = [3/4 x^2/b - 1/2 x^3/b^2]_0^b Fb 1/EJ$$

$$= (3/4 b - 1/2 b) Fb 1/EJ = 1/4 Fb^2/EJ$$

$$L_{DG}^{xo} = \int_0^b (3/2 x/b - 3/2 x^2/b^2) Fb 1/EJ dx = [3/4 x^2/b - 1/2 x^3/b^2]_0^b Fb 1/EJ$$

$$= (3/4 b - 1/2 b) Fb 1/EJ = 1/4 Fb^2/EJ$$

$$L_{GA}^{xo} = \int_0^b (-3/8 + 1/2 x/b + 1/8 x^2/b^2 - 1/4 x^3/b^3) Fb 1/EJ dx$$

$$= [-3/8 x + 1/4 x^2/b + 1/24 x^3/b^2 - 1/16 x^4/b^3]_0^b Fb 1/EJ$$

$$= (-3/8 b + 1/4 b + 1/24 b - 1/16 b) Fb 1/EJ = -7/48 Fb^2/EJ$$

$$L_{AG}^{xo} = \int_0^b (-5/8 x^2/b^2 + 1/4 x^3/b^3) Fb 1/EJ dx = [-5/24 x^3/b^2 + 1/16 x^4/b^3]_0^b Fb 1/EJ$$

$$= (-5/24 b + 1/16 b) Fb 1/EJ = -7/48 Fb^2/EJ$$

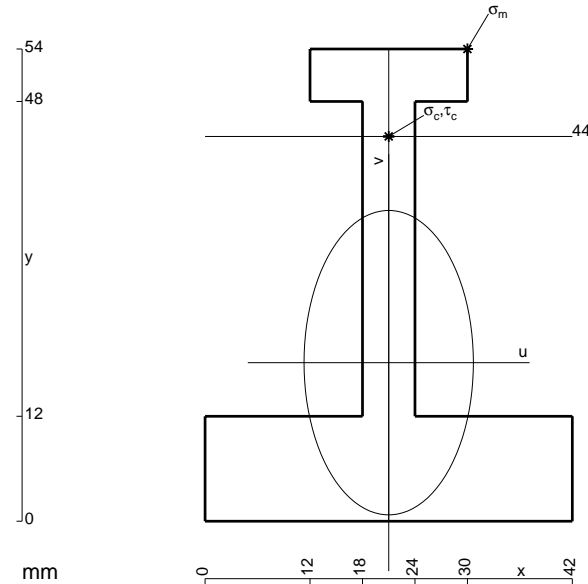

$$A = 828. \text{ mm}^2$$

$$J_u = 250978. \text{ mm}^4$$

$$J_v = 77652. \text{ mm}^4$$

$$y_g = 18.13 \text{ mm}$$

$$T_y = -2420. \text{ N}$$

$$M_x = -1597200. \text{ Nmm}$$

$$x_m = 30. \text{ mm}$$

$$y_m = 54. \text{ mm}$$

$$u_m = 9. \text{ mm}$$

$$v_m = 35.87 \text{ mm}$$

$$\sigma_m = -Mv/J_u = 228.3 \text{ N/mm}^2$$

$$x_c = 21. \text{ mm}$$

$$y_c = 44. \text{ mm}$$

$$v_c = 25.87 \text{ mm}$$

$$\sigma_c = -Mv/J_u = 164.6 \text{ N/mm}^2$$

$$\tau_c = 6.78 \text{ N/mm}^2$$

$$\sigma_\varrho = \sqrt{\sigma^2 + 3\tau^2} = 165.1 \text{ N/mm}^2$$

$$S = 4219. \text{ mm}^3$$

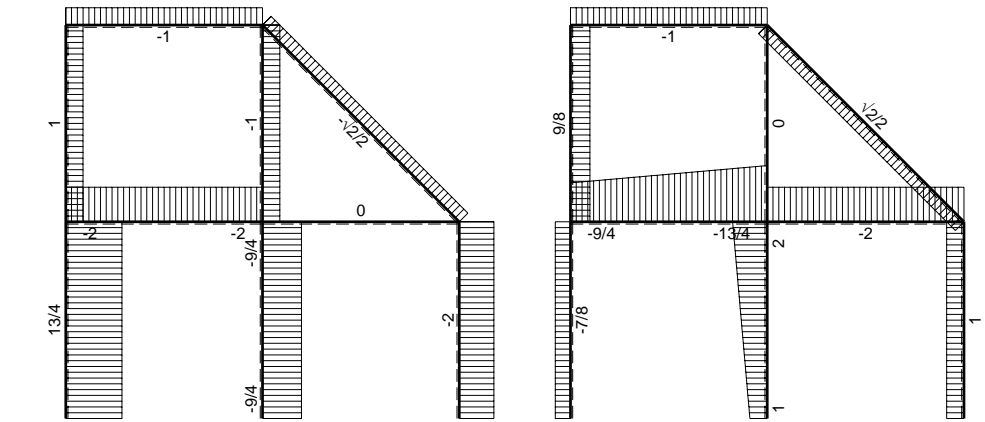
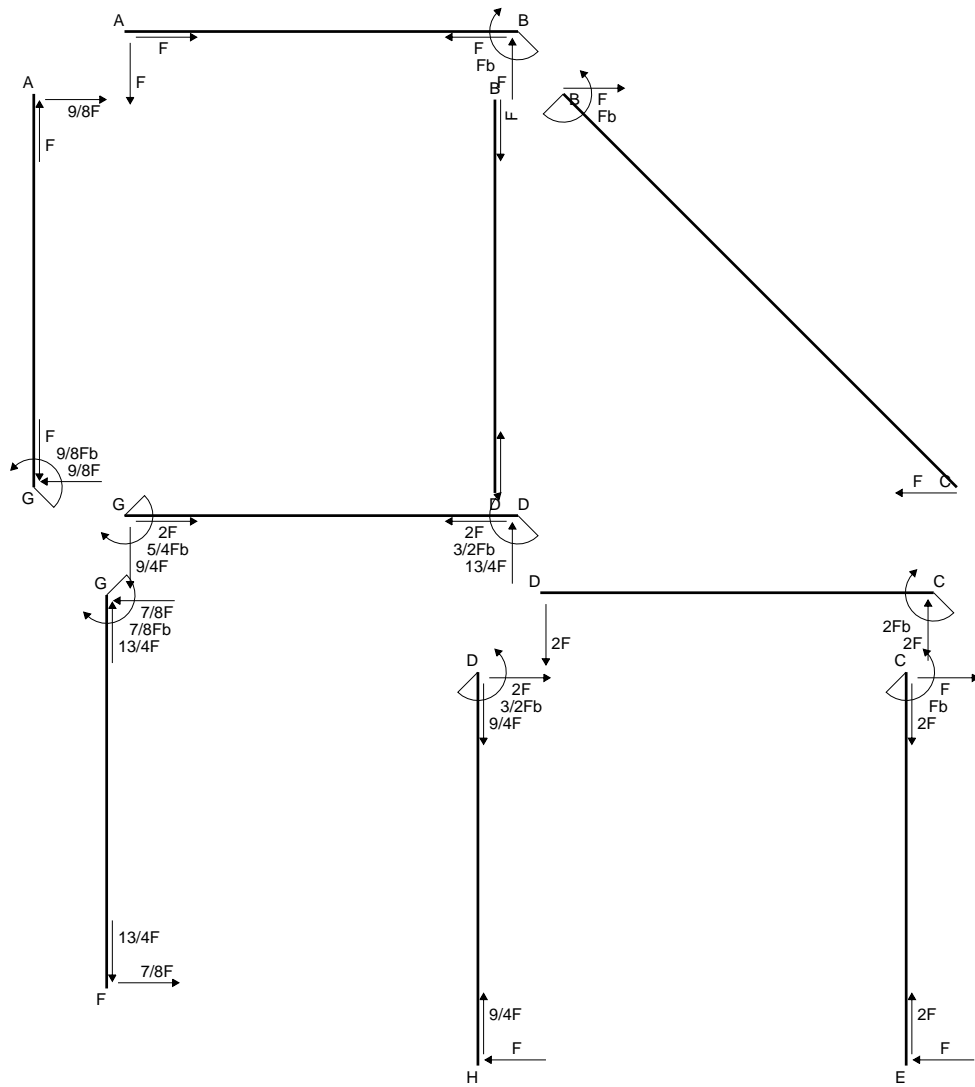

← ⊕ → F

↑ ⊕ ↓ F

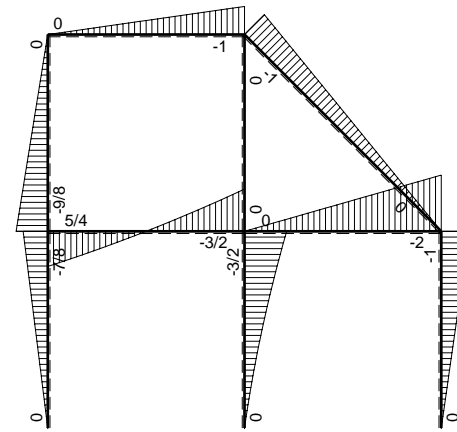

⊕ ⊖ F_b

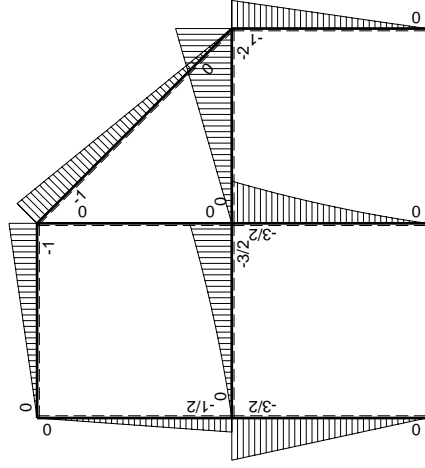
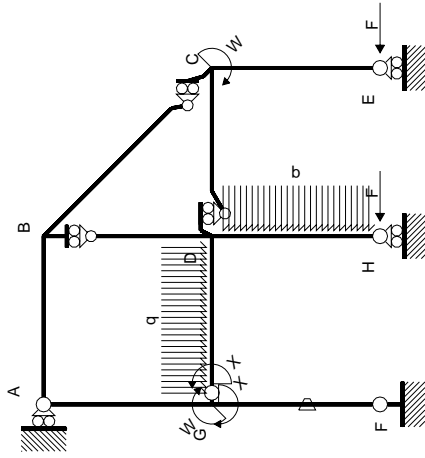

Schema di calcolo iperstatico

M_0 flessione da carichi assegnati

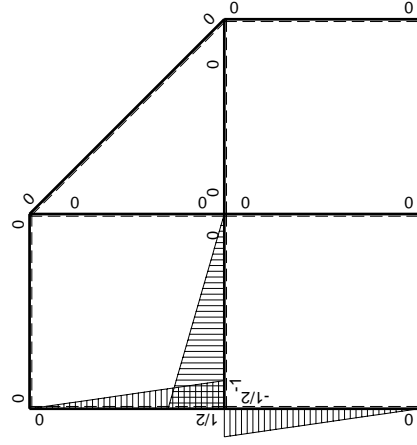

M_x flessione da iperstatica $X=1$

Quadro contributi PLV per iperstatica $X=W_{GD}$

→	$M_x(x)$	$M_o(x)$	θ	$M_x M_o$	$M_x \theta$	$M_x M_x$	$\int M_x(M_o/EJ+\theta)dx$	$\int X M_x M_x / EJ dx$
AB b	0	-Fx	0	0	0	0	0+0	0
BA b	0	Fb-Fx	0	0	0	0	0	0
BC $\sqrt{2}b$	0	-Fb+ $\sqrt{2}/2Fx$	0	0	0	0	0	0
BD b	0	0	0	0	0	0	0+0	0
DB b	0	0	0	0	0	0	0	0
DC b	0	-2Fx	0	0	0	0	0+0	0
CD b	0	2Fb-2Fx	0	0	0	0	0	0
CE b	0	-Fb+Fx	0	0	0	0	0+0	0
EC b	0	Fx	0	0	0	0	0	0
FG b	-1/2x/b	-3/2Fx	-Fb/EJ	3/4Fx ² /b	1/2Fx/EJ	1/4x ² /b ²	(1/4+1/4)Fb ² /EJ	1/12Xb/EJ
GF b	1/2-1/2x/b	3/2Fb-3/2Fx	Fb/EJ	3/4Fb-3/2Fx+3/4Fx ² /b	1/2Fb/EJ-1/2Fx/EJ	1/4-1/2x/b+1/4x ² /b ²		
GD b	-1+x/b	-Fx-1/2qx ²	0	Fx-1/2Fx ² /b-1/2qx ³ /b	0	1-2x/b+x ² /b ²	(5/24+0)Fb ² /EJ	1/3Xb/EJ
DG b	x/b	3/2Fb-2Fx+1/2qx ²	0	3/2Fx-2Fx ² /b+1/2qx ³ /b	0	x ² /b ²		
DH b	0	-3/2Fb+2Fx-1/2qx ²	0	0	0	0	0+0	0
HD b	0	Fx+1/2qx ²	0	0	0	0		
GA b	1/2-1/2x/b	-1/2Fb+1/2Fx	0	-1/4Fb+1/2Fx-1/4Fx ² /b	0	1/4-1/2x/b+1/4x ² /b ²	(-1/12+0)Fb ² /EJ	1/12Xb/EJ
AG b	-1/2x/b	1/2Fx	0	-1/4Fx ² /b	0	1/4x ² /b ²		
	totali						5/8Fb ² /EJ	1/2Xb/EJ
	iperstatica $X=W_{GD}$						-5/4Fb	

Sviluppi di calcolo iperstatica

$$L_{FG}^{xx} = \int_0^b (1/4 x^2/b^2) 1/EJ dx = [1/12 x^3/b^2]_0^b 1/EJ$$

$$= (1/12 b) 1/EJ = 1/12 b/EJ$$

$$L_{GF}^{xx} = \int_0^b (1/4 - 1/2 x/b + 1/4 x^2/b^2) 1/EJ dx = [1/4 x - 1/4 x^2/b + 1/12 x^3/b^2]_0^b 1/EJ$$

$$= (1/4 b - 1/4 b + 1/12 b) 1/EJ = 1/12 b/EJ$$

$$L_{GD}^{xx} = \int_0^b (1 - 2 x/b + x^2/b^2) 1/EJ dx = [x - x^2/b + 1/3 x^3/b^2]_0^b 1/EJ$$

$$= (b - b + 1/3 b) 1/EJ = 1/3 b/EJ$$

$$L_{DG}^{xx} = \int_0^b (x^2/b^2) 1/EJ dx = [1/3 x^3/b^2]_0^b 1/EJ$$

$$= (1/3 b) 1/EJ = 1/3 b/EJ$$

$$L_{GA}^{xx} = \int_0^b (1/4 - 1/2 x/b + 1/4 x^2/b^2) 1/EJ dx = [1/4 x - 1/4 x^2/b + 1/12 x^3/b^2]_0^b 1/EJ$$

$$= (1/4 b - 1/4 b + 1/12 b) 1/EJ = 1/12 b/EJ$$

$$L_{AG}^{xx} = \int_0^b (1/4 x^2/b^2) 1/EJ dx = [1/12 x^3/b^2]_0^b 1/EJ$$

$$= (1/12 b) 1/EJ = 1/12 b/EJ$$

$$L_{FG}^{xo} = \int_0^b (3/4 x^2/b^2) Fb 1/EJ dx + \int_0^b (1/2 x/b) \theta dx = [1/4 x^3/b^2]_0^b Fb 1/EJ + [1/4 x^2/b]_0^b \theta$$

$$= (1/4 b) Fb 1/EJ + (1/4 b) \theta = 1/2 Fb^2/EJ$$

$$L_{GF}^{xo} = \int_0^b (3/4 - 3/2 x/b + 3/4 x^2/b^2) Fb 1/EJ dx + \int_0^b (-1/2 + 1/2 x/b) \theta dx$$

$$= [3/4 x - 3/4 x^2/b + 1/4 x^3/b^2]_0^b Fb 1/EJ + [-1/2 x + 1/4 x^2/b]_0^b \theta$$

$$= (3/4 b - 3/4 b + 1/4 b) Fb 1/EJ + (-1/2 b + 1/4 b) \theta = 1/2 Fb^2/EJ$$

$$L_{GD}^{xo} = \int_0^b (x/b - 1/2 x^2/b^2 - 1/2 x^3/b^3) Fb 1/EJ dx = [1/2 x^2/b - 1/6 x^3/b^2 - 1/8 x^4/b^3]_0^b Fb 1/EJ$$

$$= (1/2 b - 1/6 b - 1/8 b) Fb 1/EJ = 5/24 Fb^2/EJ$$

$$L_{DG}^{xo} = \int_0^b (3/2 x/b - 2 x^2/b^2 + 1/2 x^3/b^3) Fb 1/EJ dx = [3/4 x^2/b - 2/3 x^3/b^2 + 1/8 x^4/b^3]_0^b Fb 1/EJ$$

$$= (3/4 b - 2/3 b + 1/8 b) Fb 1/EJ = 5/24 Fb^2/EJ$$

$$L_{GA}^{xo} = \int_0^b (-1/4 + 1/2 x/b - 1/4 x^2/b^2) Fb 1/EJ dx = [-1/4 x + 1/4 x^2/b - 1/12 x^3/b^2]_0^b Fb 1/EJ$$

$$= (-1/4 b + 1/4 b - 1/12 b) Fb 1/EJ = -1/12 Fb^2/EJ$$

$$L_{AG}^{xo} = \int_0^b (-1/4 x^2/b^2) Fb 1/EJ dx = [-1/12 x^3/b^2]_0^b Fb 1/EJ$$

$$= (-1/12 b) Fb 1/EJ = -1/12 Fb^2/EJ$$

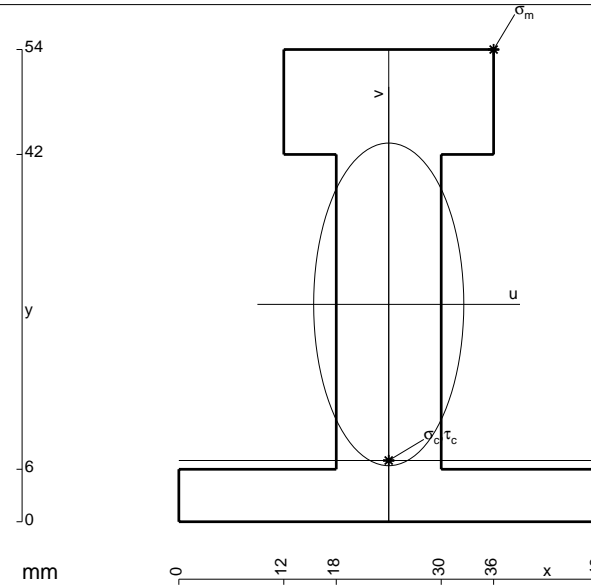

- A = 1008. mm²
- J_u = 343131. mm⁴
- J_v = 74304. mm⁴
- y_g = 24.86 mm
- T_y = -3960. N
- M_x = -2811600. Nmm
- x_m = 36. mm
- y_m = 54. mm
- u_m = 12. mm
- v_m = 29.14 mm
- σ_m = -Mv/J_u = 238.8 N/mm²
- x_c = 24. mm
- y_c = 7. mm
- v_c = -17.86 mm
- σ_c = -Mv/J_u = -146.3 N/mm²
- τ_c = 6.266 N/mm²
- σ_q = √σ²+3τ² = 146.7 N/mm²
- S = 6515. mm³

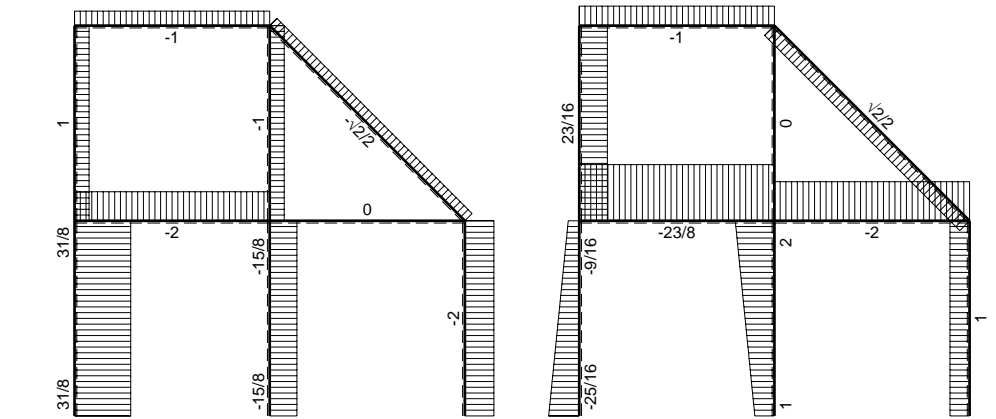
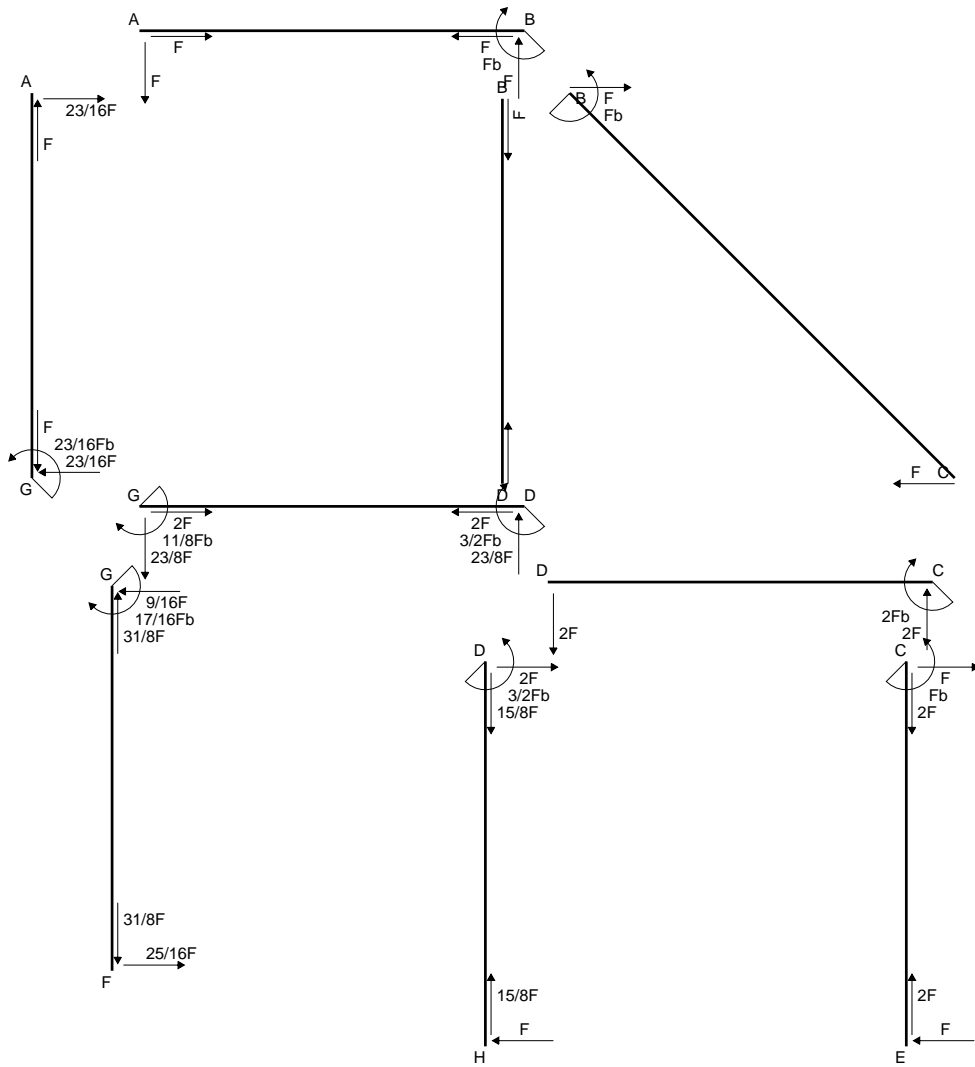

← ⊕ → F

↑ ⊕ ↓ F

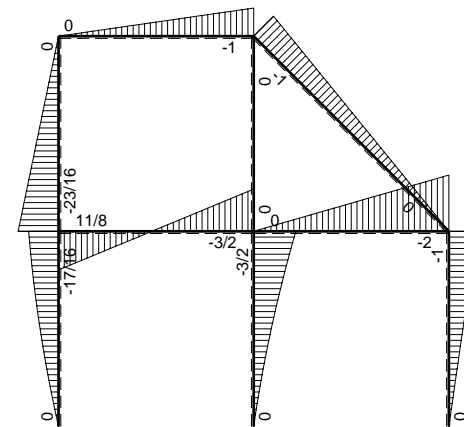

⊕ ⊖ F_b

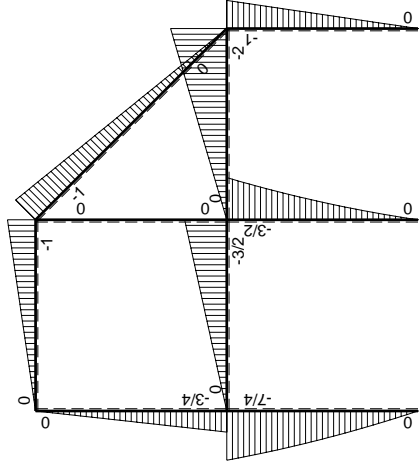
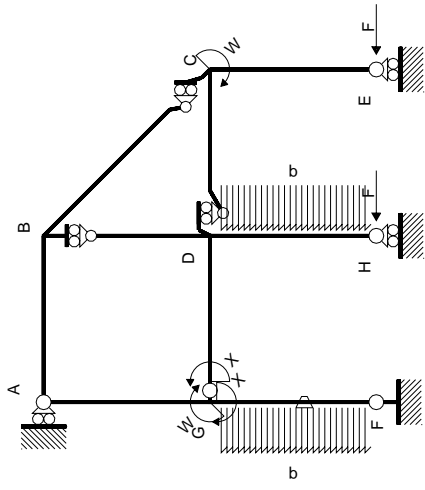

Schema di calcolo iperstatico

M_0 flessione da carichi assegnati

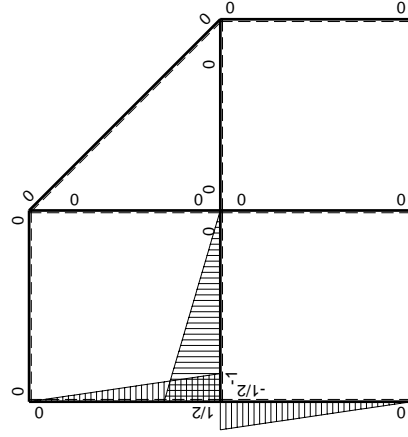

M_x flessione da iperstatica $X=1$

Quadro contributi PLV per iperstatica $X=W_{GD}$

→	$M_x(x)$	$M_o(x)$	θ	$M_x M_o$	$M_x \theta$	$M_x M_x$	$\int M_x(M_o/EJ+\theta)dx$	$\int X M_x M_x / EJ dx$
AB b	0	-Fx	0	0	0	0	0+0	0
BA b	0	Fb-Fx	0	0	0	0	0	0
BC $\sqrt{2}b$	0	-Fb+ $\sqrt{2}/2Fx$	0	0	0	0	0	0
BD b	0	0	0	0	0	0	0+0	0
DB b	0	0	0	0	0	0	0	0
DC b	0	-2Fx	0	0	0	0	0+0	0
CD b	0	2Fb-2Fx	0	0	0	0	0	0
CE b	0	-Fb+Fx	0	0	0	0	0+0	0
EC b	0	Fx	0	0	0	0	0	0
FG b	-1/2x/b	-9/4Fx+1/2qx ²	-Fb/EJ	9/8Fx ² /b-1/4qx ³ /b	1/2Fx/EJ	1/4x ² /b ²	(5/16+1/4)Fb ² /EJ	1/12Xb/EJ
GF b	1/2-1/2x/b	7/4Fb-5/4Fx-1/2qx ²	Fb/EJ	7/8Fb-3/2Fx+3/8Fx ² /b+1/4qx ³ /b	1/2Fb/EJ-1/2Fx/EJ	1/4-1/2x/b+1/4x ² /b ²		
GD b	-1+x/b	-3/2Fx	0	3/2Fx-3/2Fx ² /b	0	1-2x/b+x ² /b ²	(1/4+0)Fb ² /EJ	1/3Xb/EJ
DG b	x/b	3/2Fb-3/2Fx	0	3/2Fx-3/2Fx ² /b	0	x ² /b ²		
DH b	0	-3/2Fb+2Fx-1/2qx ²	0	0	0	0	0+0	0
HD b	0	Fx+1/2qx ²	0	0	0	0		
GA b	1/2-1/2x/b	-3/4Fb+3/4Fx	0	-3/8Fb+3/4Fx-3/8Fx ² /b	0	1/4-1/2x/b+1/4x ² /b ²	(-1/8+0)Fb ² /EJ	1/12Xb/EJ
AG b	-1/2x/b	3/4Fx	0	-3/8Fx ² /b	0	1/4x ² /b ²		
	totali						11/16Fb ² /EJ	1/2Xb/EJ
	iperstatica $X=W_{GD}$						-11/8Fb	

Sviluppi di calcolo iperstatica

$$L_{FG}^{xx} = \int_0^b (1/4 x^2/b^2) 1/EJ dx = [1/12 x^3/b^2]_0^b 1/EJ$$

$$= (1/12 b) 1/EJ = 1/12 b/EJ$$

$$L_{GF}^{xx} = \int_0^b (1/4 - 1/2 x/b + 1/4 x^2/b^2) 1/EJ dx = [1/4 x - 1/4 x^2/b + 1/12 x^3/b^2]_0^b 1/EJ$$

$$= (1/4 b - 1/4 b + 1/12 b) 1/EJ = 1/12 b/EJ$$

$$L_{GD}^{xx} = \int_0^b (1 - 2 x/b + x^2/b^2) 1/EJ dx = [x - x^2/b + 1/3 x^3/b^2]_0^b 1/EJ$$

$$= (b - b + 1/3 b) 1/EJ = 1/3 b/EJ$$

$$L_{DG}^{xx} = \int_0^b (x^2/b^2) 1/EJ dx = [1/3 x^3/b^2]_0^b 1/EJ$$

$$= (1/3 b) 1/EJ = 1/3 b/EJ$$

$$L_{GA}^{xx} = \int_0^b (1/4 - 1/2 x/b + 1/4 x^2/b^2) 1/EJ dx = [1/4 x - 1/4 x^2/b + 1/12 x^3/b^2]_0^b 1/EJ$$

$$= (1/4 b - 1/4 b + 1/12 b) 1/EJ = 1/12 b/EJ$$

$$L_{AG}^{xx} = \int_0^b (1/4 x^2/b^2) 1/EJ dx = [1/12 x^3/b^2]_0^b 1/EJ$$

$$= (1/12 b) 1/EJ = 1/12 b/EJ$$

$$L_{FG}^{x_0} = \int_0^b (9/8 x^2/b^2 - 1/4 x^3/b^3) Fb 1/EJ dx + \int_0^b (1/2 x/b) \theta dx$$

$$= [3/8 x^3/b^2 - 1/16 x^4/b^3]_0^b Fb 1/EJ + [1/4 x^2/b]_0^b \theta$$

$$= (3/8 b - 1/16 b) Fb 1/EJ + (1/4 b) \theta = 9/16 Fb^2/EJ$$

$$L_{GF}^{x_0} = \int_0^b (7/8 - 3/2 x/b + 3/8 x^2/b^2 + 1/4 x^3/b^3) Fb 1/EJ dx + \int_0^b (-1/2 + 1/2 x/b) \theta dx$$

$$= [7/8 x - 3/4 x^2/b + 1/8 x^3/b^2 + 1/16 x^4/b^3]_0^b Fb 1/EJ + [-1/2 x + 1/4 x^2/b]_0^b \theta$$

$$= (7/8 b - 3/4 b + 1/8 b + 1/16 b) Fb 1/EJ + (-1/2 b + 1/4 b) \theta = 9/16 Fb^2/EJ$$

$$L_{GD}^{x_0} = \int_0^b (3/2 x/b - 3/2 x^2/b^2) Fb 1/EJ dx = [3/4 x^2/b - 1/2 x^3/b^2]_0^b Fb 1/EJ$$

$$= (3/4 b - 1/2 b) Fb 1/EJ = 1/4 Fb^2/EJ$$

$$L_{DG}^{x_0} = \int_0^b (3/2 x/b - 3/2 x^2/b^2) Fb 1/EJ dx = [3/4 x^2/b - 1/2 x^3/b^2]_0^b Fb 1/EJ$$

$$= (3/4 b - 1/2 b) Fb 1/EJ = 1/4 Fb^2/EJ$$

$$L_{GA}^{x_0} = \int_0^b (-3/8 + 3/4 x/b - 3/8 x^2/b^2) Fb 1/EJ dx = [-3/8 x + 3/8 x^2/b - 1/8 x^3/b^2]_0^b Fb 1/EJ$$

$$= (-3/8 b + 3/8 b - 1/8 b) Fb 1/EJ = -1/8 Fb^2/EJ$$

$$L_{AG}^{x_0} = \int_0^b (-3/8 x^2/b^2) Fb 1/EJ dx = [-1/8 x^3/b^2]_0^b Fb 1/EJ$$

$$= (-1/8 b) Fb 1/EJ = -1/8 Fb^2/EJ$$

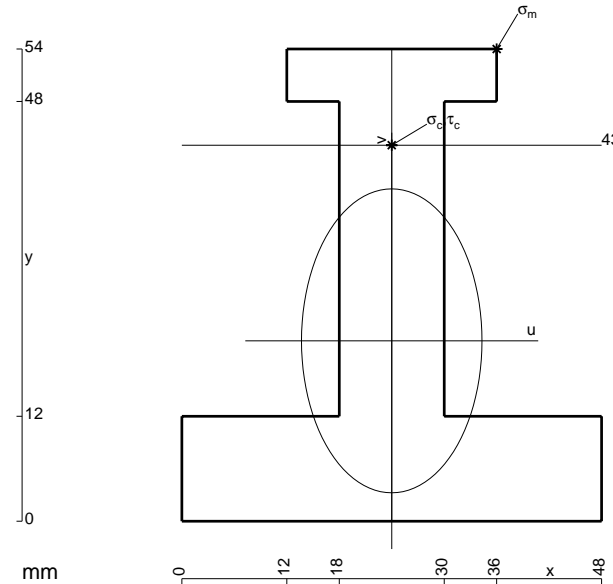

- A = 1152. mm²
- J_u = 348030. mm⁴
- J_v = 122688. mm⁴
- y_g = 20.63 mm
- T_y = -2740. N
- M_x = -2082400. Nmm
- x_m = 36. mm
- y_m = 54. mm
- u_m = 12. mm
- v_m = 33.38 mm
- σ_m = -Mv/J_u = 199.7 N/mm²
- x_c = 24. mm
- y_c = 43. mm
- v_c = 22.38 mm
- σ_c = -Mv/J_u = 133.9 N/mm²
- τ_c = 3.849 N/mm²
- σ_o = √σ²+3τ² = 134. N/mm²
- S = 5867. mm³

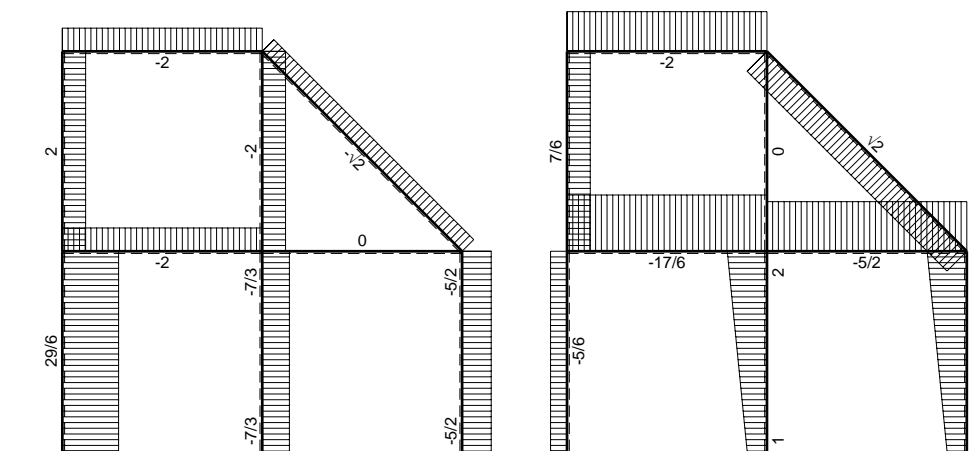
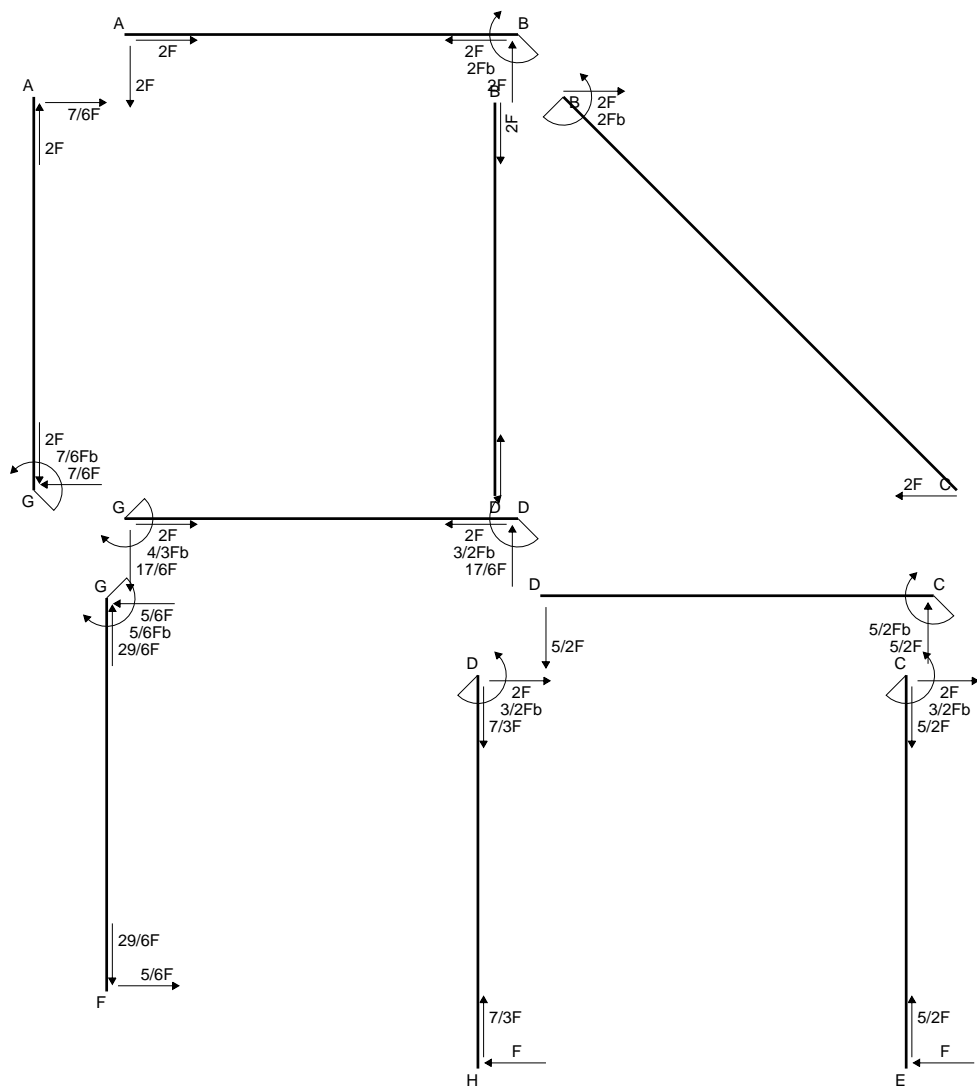

$\leftarrow \boxed{+} \rightarrow F$

$\uparrow \boxed{+} \downarrow F$

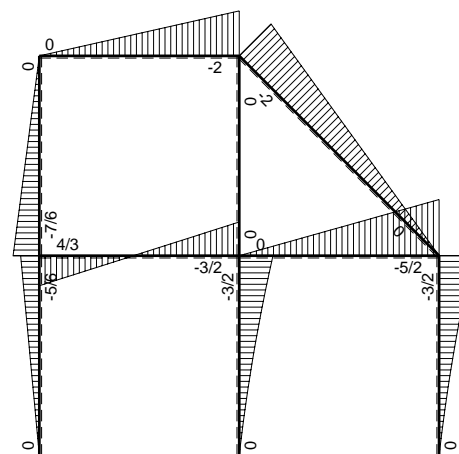

$\curvearrowright \boxed{+} \curvearrowleft F_b$

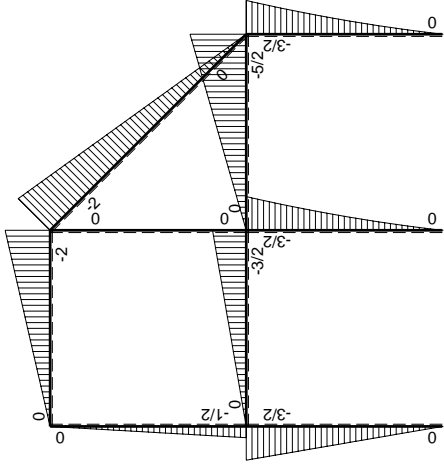
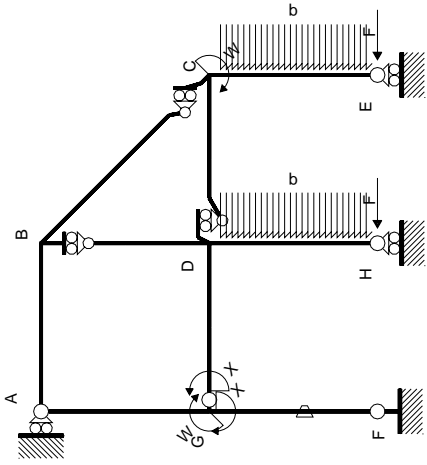

Schema di calcolo iperstatico

M_0 flessione da carichi assegnati

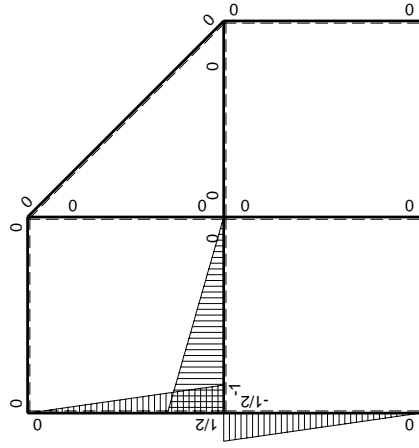

M_1 flessione da iperstatica $X=1$

Quadro contributi PLV per iperstatica $X=W_{GD}$

→	$M_x(x)$	$M_o(x)$	θ	$M_x M_o$	$M_x \theta$	$M_x M_x$	$\int M_x(M_o/EJ+\theta)dx$	$\int X M_x M_x/EJ dx$
AB b	0	-2Fx	0	0	0	0	0+0	0
BA b	0	2Fb-2Fx	0	0	0	0	0	0
BC $\sqrt{2}b$	0	-2Fb+ $\sqrt{2}Fx$	0	0	0	0	0	0
BD b	0	0	0	0	0	0	0+0	0
DB b	0	0	0	0	0	0	0	0
DC b	0	-5/2Fx	0	0	0	0	0+0	0
CD b	0	5/2Fb-5/2Fx	0	0	0	0	0	0
CE b	0	-3/2Fb+2Fx-1/2qx ²	0	0	0	0	0+0	0
EC b	0	Fx+1/2qx ²	0	0	0	0	0	0
FG b	-1/2x/b	-3/2Fx	-Fb/EJ	3/4Fx ² /b	1/2Fx/EJ	1/4x ² /b ²	(1/4+1/4)Fb ² /EJ	1/12Xb/EJ
GF b	1/2-1/2x/b	3/2Fb-3/2Fx	Fb/EJ	3/4Fb-3/2Fx+3/4Fx ² /b	1/2Fb/EJ-1/2Fx/EJ	1/4-1/2x/b+1/4x ² /b ²		
GD b	-1+x/b	-3/2Fx	0	3/2Fx-3/2Fx ² /b	0	1-2x/b+x ² /b ²	(1/4+0)Fb ² /EJ	1/3Xb/EJ
DG b	x/b	3/2Fb-3/2Fx	0	3/2Fx-3/2Fx ² /b	0	x ² /b ²		
DH b	0	-3/2Fb+2Fx-1/2qx ²	0	0	0	0	0+0	0
HD b	0	Fx+1/2qx ²	0	0	0	0	0	0
GA b	1/2-1/2x/b	-1/2Fb+1/2Fx	0	-1/4Fb+1/2Fx-1/4Fx ² /b	0	1/4-1/2x/b+1/4x ² /b ²	(-1/12+0)Fb ² /EJ	1/12Xb/EJ
AG b	-1/2x/b	1/2Fx	0	-1/4Fx ² /b	0	1/4x ² /b ²		
	totali						2/3Fb ² /EJ	1/2Xb/EJ
	iperstatica $X=W_{GD}$						-4/3Fb	

Sviluppi di calcolo iperstatica

$$L_{FG}^{xx} = \int_0^b (1/4 x^2/b^2) 1/EJ dx = [1/12 x^3/b^2]_0^b 1/EJ$$

$$= (1/12 b) 1/EJ = 1/12 b/EJ$$

$$L_{GF}^{xx} = \int_0^b (1/4 - 1/2 x/b + 1/4 x^2/b^2) 1/EJ dx = [1/4 x - 1/4 x^2/b + 1/12 x^3/b^2]_0^b 1/EJ$$

$$= (1/4 b - 1/4 b + 1/12 b) 1/EJ = 1/12 b/EJ$$

$$L_{GD}^{xx} = \int_0^b (1 - 2 x/b + x^2/b^2) 1/EJ dx = [x - x^2/b + 1/3 x^3/b^2]_0^b 1/EJ$$

$$= (b - b + 1/3 b) 1/EJ = 1/3 b/EJ$$

$$L_{DG}^{xx} = \int_0^b (x^2/b^2) 1/EJ dx = [1/3 x^3/b^2]_0^b 1/EJ$$

$$= (1/3 b) 1/EJ = 1/3 b/EJ$$

$$L_{GA}^{xx} = \int_0^b (1/4 - 1/2 x/b + 1/4 x^2/b^2) 1/EJ dx = [1/4 x - 1/4 x^2/b + 1/12 x^3/b^2]_0^b 1/EJ$$

$$= (1/4 b - 1/4 b + 1/12 b) 1/EJ = 1/12 b/EJ$$

$$L_{AG}^{xx} = \int_0^b (1/4 x^2/b^2) 1/EJ dx = [1/12 x^3/b^2]_0^b 1/EJ$$

$$= (1/12 b) 1/EJ = 1/12 b/EJ$$

$$L_{FG}^{xo} = \int_0^b (3/4 x^2/b^2) Fb 1/EJ dx + \int_0^b (1/2 x/b) \theta dx = [1/4 x^3/b^2]_0^b Fb 1/EJ + [1/4 x^2/b]_0^b \theta$$

$$= (1/4 b) Fb 1/EJ + (1/4 b) \theta = 1/2 Fb^2/EJ$$

$$L_{GF}^{xo} = \int_0^b (3/4 - 3/2 x/b + 3/4 x^2/b^2) Fb 1/EJ dx + \int_0^b (-1/2 + 1/2 x/b) \theta dx$$

$$= [3/4 x - 3/4 x^2/b + 1/4 x^3/b^2]_0^b Fb 1/EJ + [-1/2 x + 1/4 x^2/b]_0^b \theta$$

$$= (3/4 b - 3/4 b + 1/4 b) Fb 1/EJ + (-1/2 b + 1/4 b) \theta = 1/2 Fb^2/EJ$$

$$L_{GD}^{xo} = \int_0^b (3/2 x/b - 3/2 x^2/b^2) Fb 1/EJ dx = [3/4 x^2/b - 1/2 x^3/b^2]_0^b Fb 1/EJ$$

$$= (3/4 b - 1/2 b) Fb 1/EJ = 1/4 Fb^2/EJ$$

$$L_{DG}^{xo} = \int_0^b (3/2 x/b - 3/2 x^2/b^2) Fb 1/EJ dx = [3/4 x^2/b - 1/2 x^3/b^2]_0^b Fb 1/EJ$$

$$= (3/4 b - 1/2 b) Fb 1/EJ = 1/4 Fb^2/EJ$$

$$L_{GA}^{xo} = \int_0^b (-1/4 + 1/2 x/b - 1/4 x^2/b^2) Fb 1/EJ dx = [-1/4 x + 1/4 x^2/b - 1/12 x^3/b^2]_0^b Fb 1/EJ$$

$$= (-1/4 b + 1/4 b - 1/12 b) Fb 1/EJ = -1/12 Fb^2/EJ$$

$$L_{AG}^{xo} = \int_0^b (-1/4 x^2/b^2) Fb 1/EJ dx = [-1/12 x^3/b^2]_0^b Fb 1/EJ$$

$$= (-1/12 b) Fb 1/EJ = -1/12 Fb^2/EJ$$

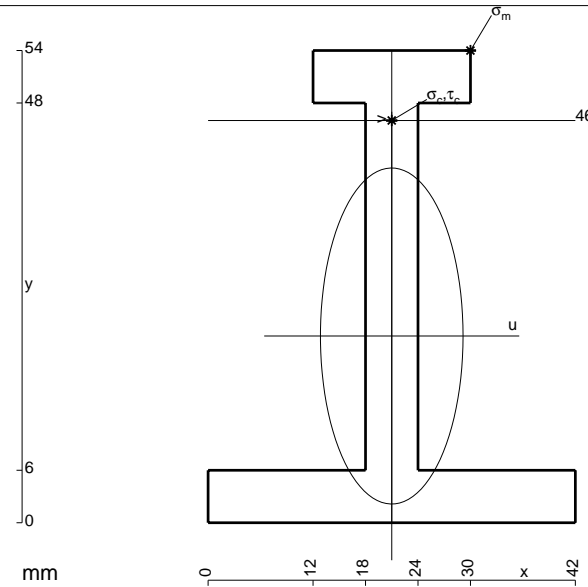

- A = 612. mm²
- J_u = 225968. mm⁴
- J_v = 40716. mm⁴
- y_g = 21.35 mm
- T_y = -1775. N
- M_x = -1437750. Nmm
- x_m = 30. mm
- y_m = 54. mm
- u_m = 9. mm
- v_m = 32.65 mm
- σ_m = -Mv/J_u = 207.7 N/mm²
- x_c = 21. mm
- y_c = 46. mm
- v_c = 24.65 mm
- σ_c = -Mv/J_u = 156.8 N/mm²
- τ_c = 4.595 N/mm²
- σ_q = √(σ²+3τ²) = 157. N/mm²
- S = 3510. mm³

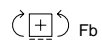
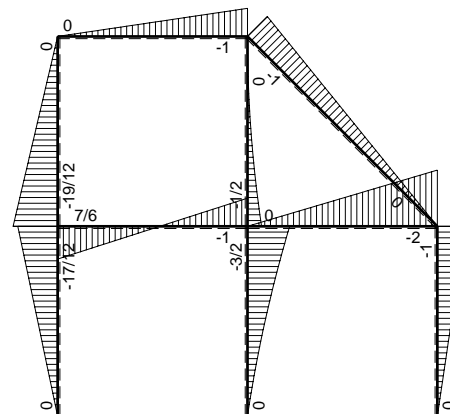
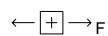
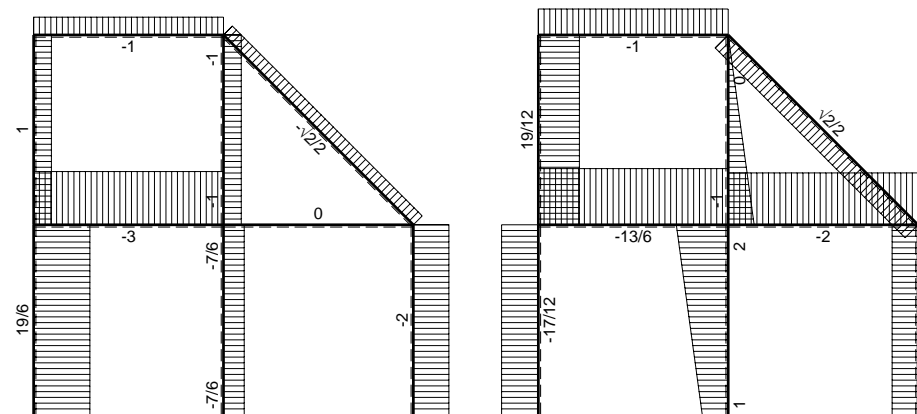
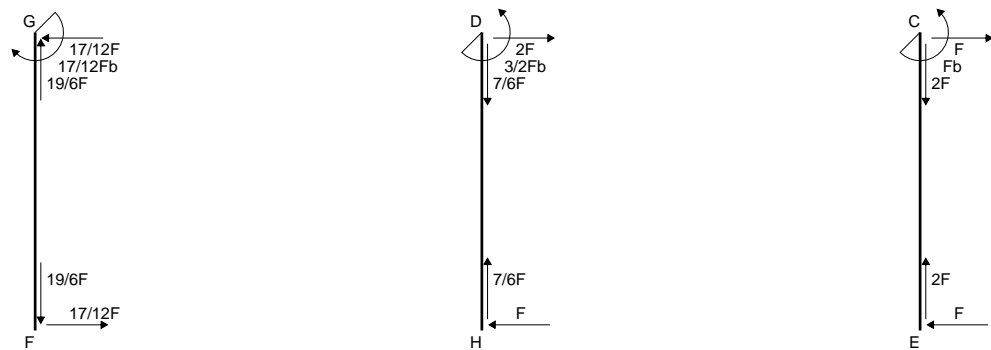
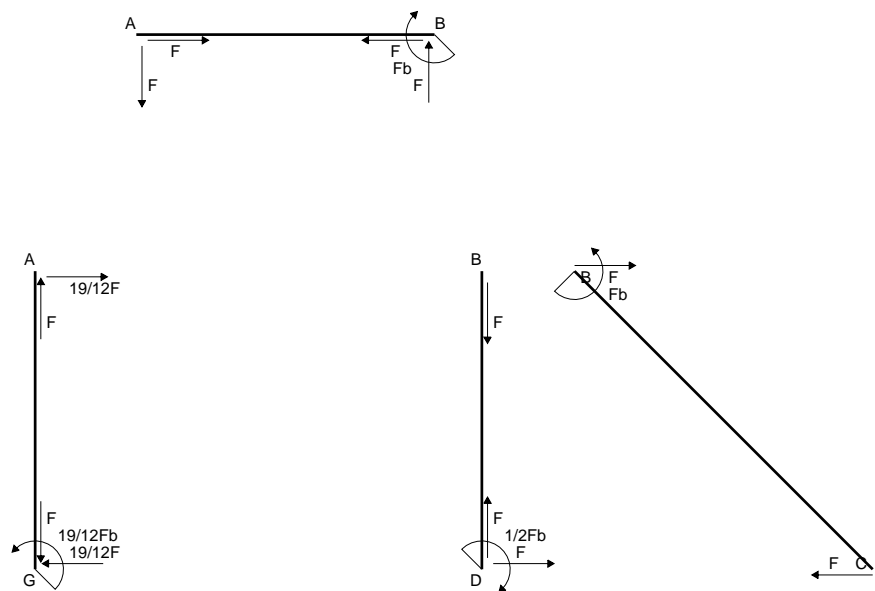

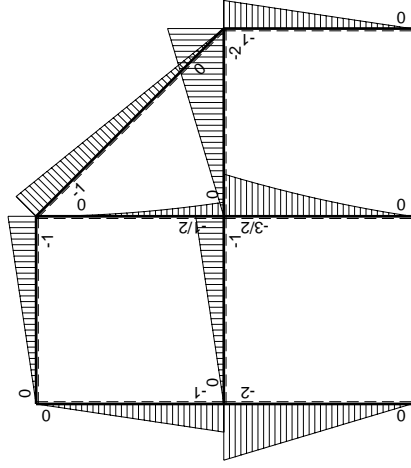
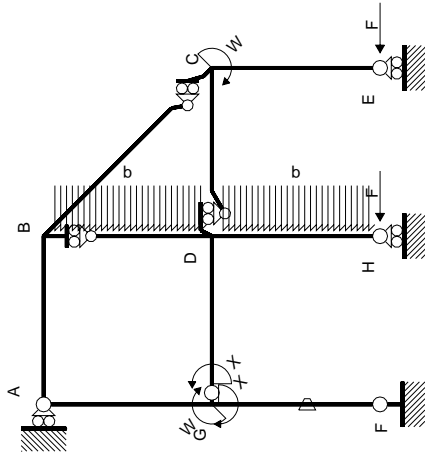

Schema di calcolo iperstatico

M_0 flessione da carichi assegnati

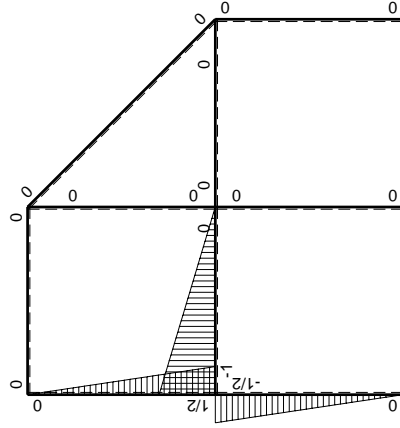

M_x flessione da iperstatica $X=1$

Quadro contributi PLV per iperstatica $X=W_{GD}$

→	$M_x(x)$	$M_o(x)$	θ	$M_x M_o$	$M_x \theta$	$M_x M_x$	$\int M_x(M_o/EJ+\theta)dx$	$\int X M_x M_x/EJ dx$	
AB b	0	-Fx	0	0	0	0	0+0	0	
BA b	0	Fb-Fx	0	0	0	0	0	0	
BC $\sqrt{2}b$	0	-Fb+ $\sqrt{2}/2Fx$	0	0	0	0	0	0	
BD b	0	-1/2qx ²	0	0	0	0	0+0	0	
DB b	0	1/2Fb-Fx+1/2qx ²	0	0	0	0	0	0	
DC b	0	-2Fx	0	0	0	0	0+0	0	
CD b	0	2Fb-2Fx	0	0	0	0	0	0	
CE b	0	-Fb+Fx	0	0	0	0	0+0	0	
EC b	0	Fx	0	0	0	0	0	0	
FG b	-1/2x/b	-2Fx	-Fb/EJ	Fx ² /b	1/2Fx/EJ	1/4x ² /b ²	(1/3+1/4)Fb ² /EJ	1/12Xb/EJ	
GF b	1/2-1/2x/b	2Fb-2Fx	Fb/EJ	Fb-2Fx+Fx ² /b	1/2Fb/EJ-1/2Fx/EJ	1/4-1/2x/b+1/4x ² /b ²			
GD b	-1+x/b	-Fx	0	Fx-Fx ² /b	0	1-2x/b+x ² /b ²	(1/6+0)Fb ² /EJ	1/3Xb/EJ	
DG b	x/b	Fb-Fx	0	Fx-Fx ² /b	0	x ² /b ²			
DH b	0	-3/2Fb+2Fx-1/2qx ²	0	0	0	0	0+0	0	
HD b	0	Fx+1/2qx ²	0	0	0	0			
GA b	1/2-1/2x/b	-Fb+Fx	0	-1/2Fb+Fx-1/2Fx ² /b	0	1/4-1/2x/b+1/4x ² /b ²	(-1/6+0)Fb ² /EJ	1/12Xb/EJ	
AG b	-1/2x/b	Fx	0	-1/2Fx ² /b	0	1/4x ² /b ²			
	totali							7/12Fb ² /EJ	1/2Xb/EJ
	iperstatica $X=W_{GD}$							-7/6Fb	

Sviluppi di calcolo iperstatica

$$L_{FG}^{xx} = \int_0^b (1/4 x^2/b^2) 1/EJ dx = [1/12 x^3/b^2]_0^b 1/EJ$$

$$= (1/12 b) 1/EJ = 1/12 b/EJ$$

$$L_{GF}^{xx} = \int_0^b (1/4 - 1/2 x/b + 1/4 x^2/b^2) 1/EJ dx = [1/4 x - 1/4 x^2/b + 1/12 x^3/b^2]_0^b 1/EJ$$

$$= (1/4 b - 1/4 b + 1/12 b) 1/EJ = 1/12 b/EJ$$

$$L_{GD}^{xx} = \int_0^b (1 - 2 x/b + x^2/b^2) 1/EJ dx = [x - x^2/b + 1/3 x^3/b^2]_0^b 1/EJ$$

$$= (b - b + 1/3 b) 1/EJ = 1/3 b/EJ$$

$$L_{DG}^{xx} = \int_0^b (x^2/b^2) 1/EJ dx = [1/3 x^3/b^2]_0^b 1/EJ$$

$$= (1/3 b) 1/EJ = 1/3 b/EJ$$

$$L_{GA}^{xx} = \int_0^b (1/4 - 1/2 x/b + 1/4 x^2/b^2) 1/EJ dx = [1/4 x - 1/4 x^2/b + 1/12 x^3/b^2]_0^b 1/EJ$$

$$= (1/4 b - 1/4 b + 1/12 b) 1/EJ = 1/12 b/EJ$$

$$L_{AG}^{xx} = \int_0^b (1/4 x^2/b^2) 1/EJ dx = [1/12 x^3/b^2]_0^b 1/EJ$$

$$= (1/12 b) 1/EJ = 1/12 b/EJ$$

$$L_{FG}^{xo} = \int_0^b (x^2/b^2) Fb 1/EJ dx + \int_0^b (1/2 x/b) \theta dx = [1/3 x^3/b^2]_0^b Fb 1/EJ + [1/4 x^2/b]_0^b \theta$$

$$= (1/3 b) Fb 1/EJ + (1/4 b) \theta = 7/12 Fb^2/EJ$$

$$L_{GF}^{xo} = \int_0^b (1 - 2 x/b + x^2/b^2) Fb 1/EJ dx + \int_0^b (-1/2 + 1/2 x/b) \theta dx$$

$$= [x - x^2/b + 1/3 x^3/b^2]_0^b Fb 1/EJ + [-1/2 x + 1/4 x^2/b]_0^b \theta$$

$$= (b - b + 1/3 b) Fb 1/EJ + (-1/2 b + 1/4 b) \theta = 7/12 Fb^2/EJ$$

$$L_{GD}^{xo} = \int_0^b (x/b - x^2/b^2) Fb 1/EJ dx = [1/2 x^2/b - 1/3 x^3/b^2]_0^b Fb 1/EJ$$

$$= (1/2 b - 1/3 b) Fb 1/EJ = 1/6 Fb^2/EJ$$

$$L_{DG}^{xo} = \int_0^b (x/b - x^2/b^2) Fb 1/EJ dx = [1/2 x^2/b - 1/3 x^3/b^2]_0^b Fb 1/EJ$$

$$= (1/2 b - 1/3 b) Fb 1/EJ = 1/6 Fb^2/EJ$$

$$L_{GA}^{xo} = \int_0^b (-1/2 + x/b - 1/2 x^2/b^2) Fb 1/EJ dx = [-1/2 x + 1/2 x^2/b - 1/6 x^3/b^2]_0^b Fb 1/EJ$$

$$= (-1/2 b + 1/2 b - 1/6 b) Fb 1/EJ = -1/6 Fb^2/EJ$$

$$L_{AG}^{xo} = \int_0^b (-1/2 x^2/b^2) Fb 1/EJ dx = [-1/6 x^3/b^2]_0^b Fb 1/EJ$$

$$= (-1/6 b) Fb 1/EJ = -1/6 Fb^2/EJ$$

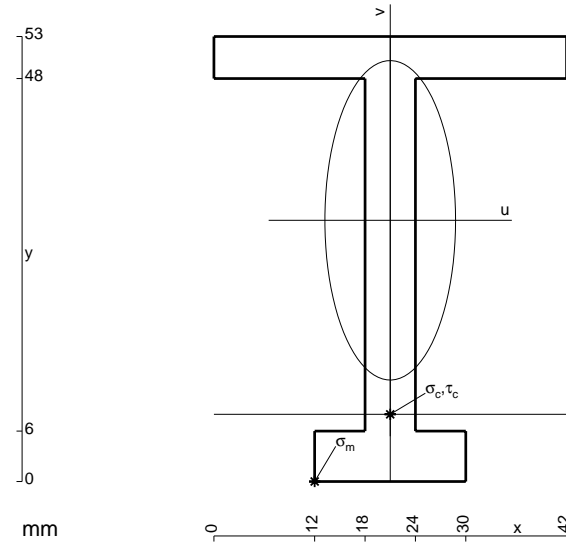

- A = 570. mm²
- J_u = 206355. mm⁴
- J_v = 34542. mm⁴
- y_g = 31.11 mm
- T_y = -1700. N
- M_x = -1445000. Nmm
- x_m = 12. mm
- u_m = -9. mm
- v_m = -31.11 mm
- σ_m = -Mv/J_u = -217.9 N/mm²
- x_c = 21. mm
- y_c = 8. mm
- v_c = -23.11 mm
- σ_c = -Mv/J_u = -161.8 N/mm²
- τ_c = 4.566 N/mm²
- σ_q = √(σ²+3τ²) = 162. N/mm²
- S = 3325. mm³

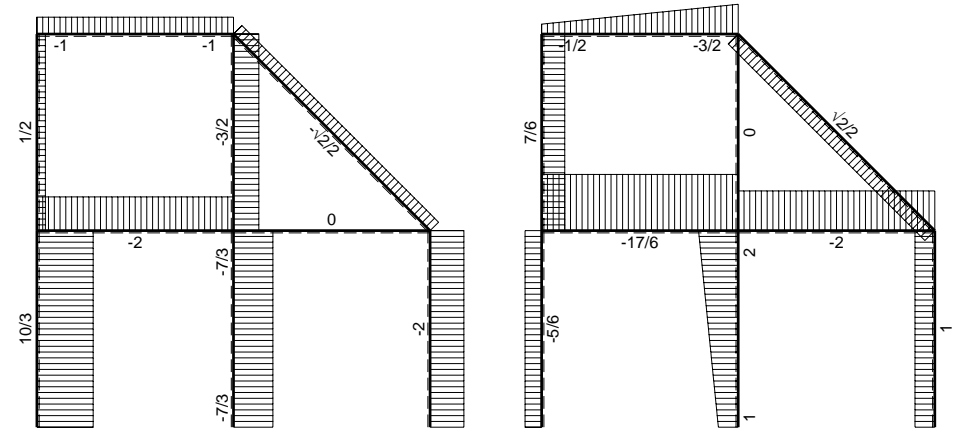
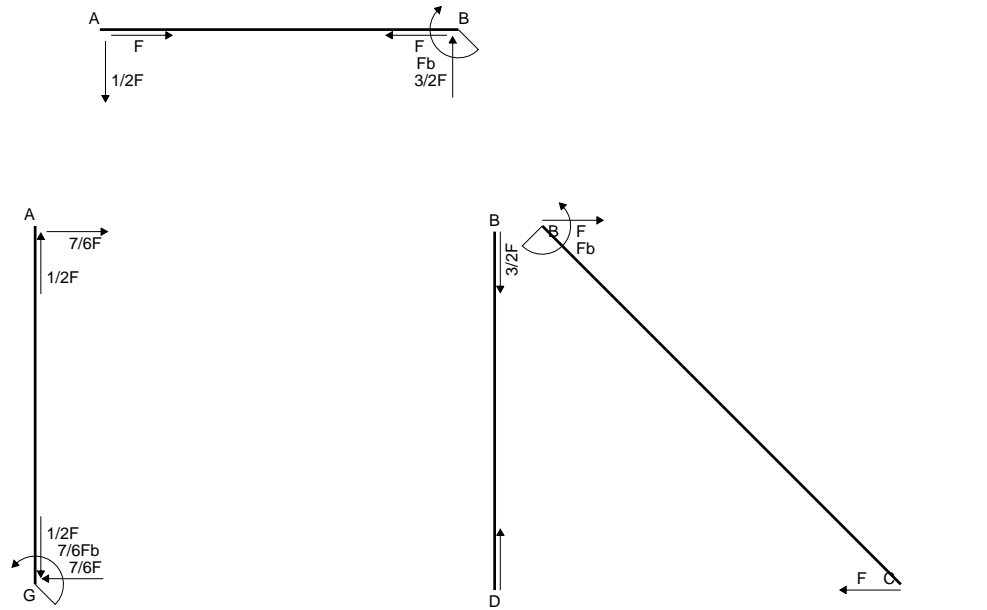

← ⊕ → F

↑ ⊕ ↓ F

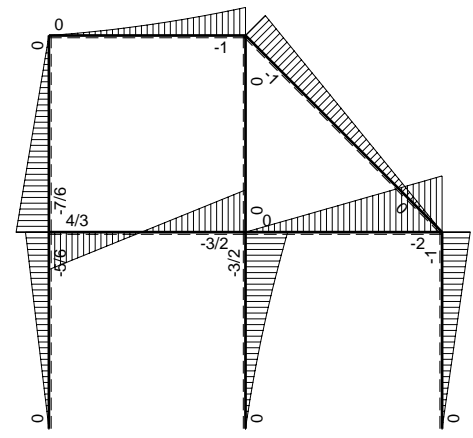
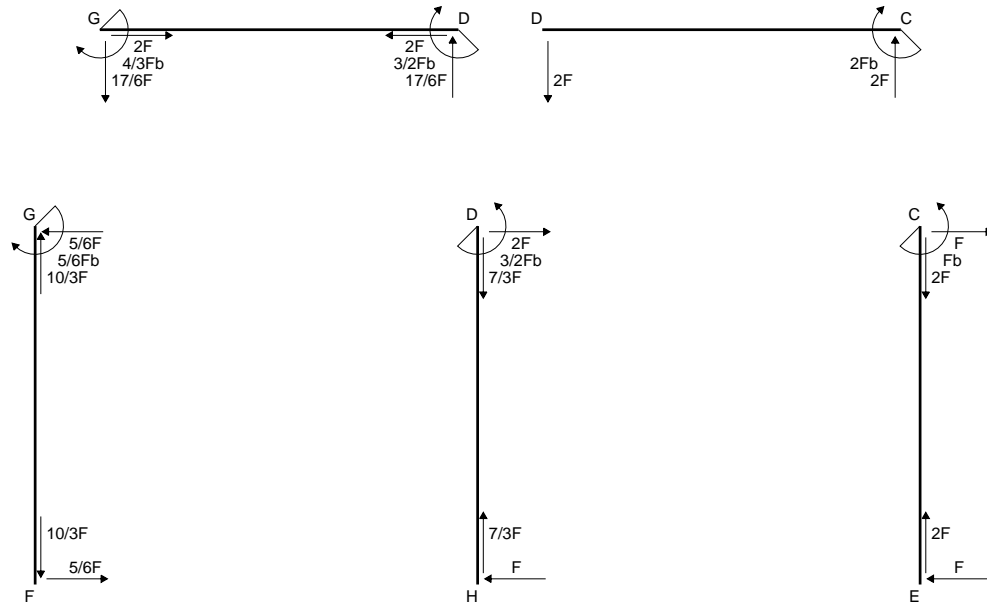

⊕ ⊖ Fb

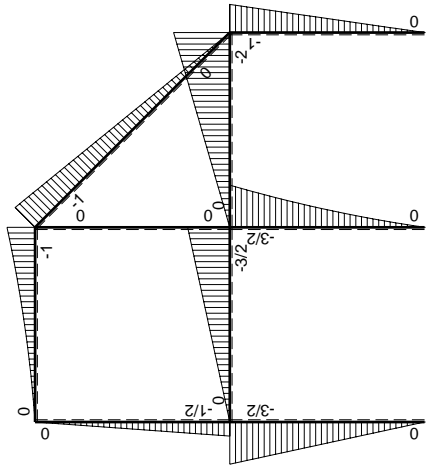
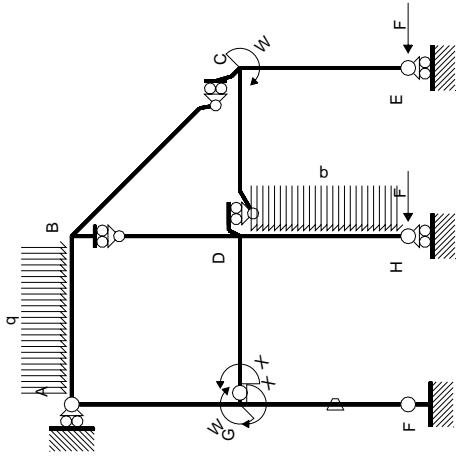

Schema di calcolo iperstatico

M_0 flessione da carichi assegnati

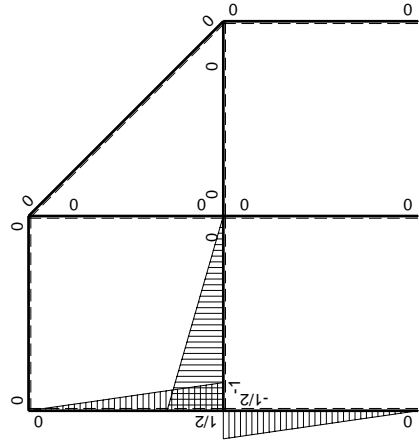

M_1 flessione da iperstatica $X=1$

Quadro contributi PLV per iperstatica $X=W_{GD}$

→	$M_x(x)$	$M_o(x)$	θ	$M_x M_o$	$M_x \theta$	$M_x M_x$	$\int M_x(M_o/EJ+\theta)dx$	$\int X M_x M_x/EJdx$
AB b	0	$-1/2Fx-1/2qx^2$	0	0	0	0	0+0	0
BA b	0	$Fb-3/2Fx+1/2qx^2$	0	0	0	0	0	0
BC $\sqrt{2}b$	0	$-Fb+\sqrt{2}/2Fx$	0	0	0	0	0	0
BD b	0	0	0	0	0	0	0+0	0
DB b	0	0	0	0	0	0	0	0
DC b	0	$-2Fx$	0	0	0	0	0+0	0
CD b	0	$2Fb-2Fx$	0	0	0	0	0	0
CE b	0	$-Fb+Fx$	0	0	0	0	0+0	0
EC b	0	Fx	0	0	0	0	0	0
FG b	$-1/2x/b$	$-3/2Fx$	$-Fb/EJ$	$3/4Fx^2/b$	$1/2Fx/EJ$	$1/4x^2/b^2$	$(1/4+1/4)Fb^2/EJ$	$1/12Xb/EJ$
GF b	$1/2-1/2x/b$	$3/2Fb-3/2Fx$	Fb/EJ	$3/4Fb-3/2Fx+3/4Fx^2/b$	$1/2Fb/EJ-1/2Fx/EJ$	$1/4-1/2x/b+1/4x^2/b^2$		
GD b	$-1+x/b$	$-3/2Fx$	0	$3/2Fx-3/2Fx^2/b$	0	$1-2x/b+x^2/b^2$	$(1/4+0)Fb^2/EJ$	$1/3Xb/EJ$
DG b	x/b	$3/2Fb-3/2Fx$	0	$3/2Fx-3/2Fx^2/b$	0	x^2/b^2		
DH b	0	$-3/2Fb+2Fx-1/2qx^2$	0	0	0	0	0+0	0
HD b	0	$Fx+1/2qx^2$	0	0	0	0	0	0
GA b	$1/2-1/2x/b$	$-1/2Fb+1/2Fx$	0	$-1/4Fb+1/2Fx-1/4Fx^2/b$	0	$1/4-1/2x/b+1/4x^2/b^2$	$(-1/12+0)Fb^2/EJ$	$1/12Xb/EJ$
AG b	$-1/2x/b$	$1/2Fx$	0	$-1/4Fx^2/b$	0	$1/4x^2/b^2$		
	totali						$2/3Fb^2/EJ$	$1/2Xb/EJ$
	iperstatica $X=W_{GD}$						$-4/3Fb$	

Sviluppi di calcolo iperstatica

$$L_{FG}^{xx} = \int_0^b (1/4 x^2/b^2) 1/EJ dx = [1/12 x^3/b^2]_0^b 1/EJ$$

$$= (1/12 b) 1/EJ = 1/12 b/EJ$$

$$L_{GF}^{xx} = \int_0^b (1/4 - 1/2 x/b + 1/4 x^2/b^2) 1/EJ dx = [1/4 x - 1/4 x^2/b + 1/12 x^3/b^2]_0^b 1/EJ$$

$$= (1/4 b - 1/4 b + 1/12 b) 1/EJ = 1/12 b/EJ$$

$$L_{GD}^{xx} = \int_0^b (1 - 2 x/b + x^2/b^2) 1/EJ dx = [x - x^2/b + 1/3 x^3/b^2]_0^b 1/EJ$$

$$= (b - b + 1/3 b) 1/EJ = 1/3 b/EJ$$

$$L_{DG}^{xx} = \int_0^b (x^2/b^2) 1/EJ dx = [1/3 x^3/b^2]_0^b 1/EJ$$

$$= (1/3 b) 1/EJ = 1/3 b/EJ$$

$$L_{GA}^{xx} = \int_0^b (1/4 - 1/2 x/b + 1/4 x^2/b^2) 1/EJ dx = [1/4 x - 1/4 x^2/b + 1/12 x^3/b^2]_0^b 1/EJ$$

$$= (1/4 b - 1/4 b + 1/12 b) 1/EJ = 1/12 b/EJ$$

$$L_{AG}^{xx} = \int_0^b (1/4 x^2/b^2) 1/EJ dx = [1/12 x^3/b^2]_0^b 1/EJ$$

$$= (1/12 b) 1/EJ = 1/12 b/EJ$$

$$L_{FG}^{xo} = \int_0^b (3/4 x^2/b^2) Fb 1/EJ dx + \int_0^b (1/2 x/b) \theta dx = [1/4 x^3/b^2]_0^b Fb 1/EJ + [1/4 x^2/b]_0^b \theta$$

$$= (1/4 b) Fb 1/EJ + (1/4 b) \theta = 1/2 Fb^2/EJ$$

$$L_{GF}^{xo} = \int_0^b (3/4 - 3/2 x/b + 3/4 x^2/b^2) Fb 1/EJ dx + \int_0^b (-1/2 + 1/2 x/b) \theta dx$$

$$= [3/4 x - 3/4 x^2/b + 1/4 x^3/b^2]_0^b Fb 1/EJ + [-1/2 x + 1/4 x^2/b]_0^b \theta$$

$$= (3/4 b - 3/4 b + 1/4 b) Fb 1/EJ + (-1/2 b + 1/4 b) \theta = 1/2 Fb^2/EJ$$

$$L_{GD}^{xo} = \int_0^b (3/2 x/b - 3/2 x^2/b^2) Fb 1/EJ dx = [3/4 x^2/b - 1/2 x^3/b^2]_0^b Fb 1/EJ$$

$$= (3/4 b - 1/2 b) Fb 1/EJ = 1/4 Fb^2/EJ$$

$$L_{DG}^{xo} = \int_0^b (3/2 x/b - 3/2 x^2/b^2) Fb 1/EJ dx = [3/4 x^2/b - 1/2 x^3/b^2]_0^b Fb 1/EJ$$

$$= (3/4 b - 1/2 b) Fb 1/EJ = 1/4 Fb^2/EJ$$

$$L_{GA}^{xo} = \int_0^b (-1/4 + 1/2 x/b - 1/4 x^2/b^2) Fb 1/EJ dx = [-1/4 x + 1/4 x^2/b - 1/12 x^3/b^2]_0^b Fb 1/EJ$$

$$= (-1/4 b + 1/4 b - 1/12 b) Fb 1/EJ = -1/12 Fb^2/EJ$$

$$L_{AG}^{xo} = \int_0^b (-1/4 x^2/b^2) Fb 1/EJ dx = [-1/12 x^3/b^2]_0^b Fb 1/EJ$$

$$= (-1/12 b) Fb 1/EJ = -1/12 Fb^2/EJ$$

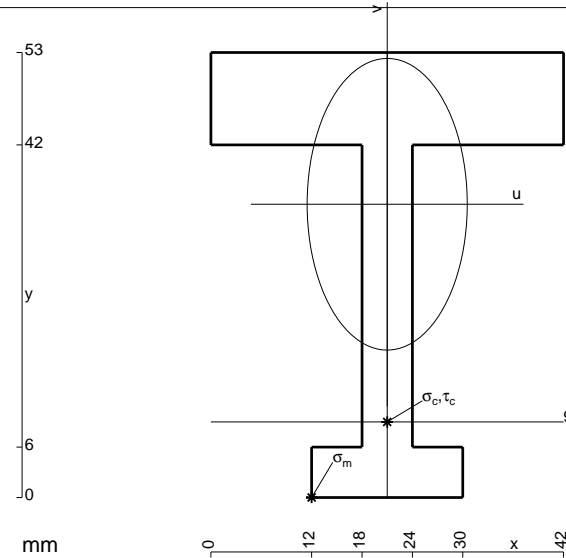

$$A = 786. \text{ mm}^2$$

$$J_u = 237222. \text{ mm}^4$$

$$J_v = 71478. \text{ mm}^4$$

$$y_g = 34.93 \text{ mm}$$

$$T_y = -1720. \text{ N}$$

$$M_x = -1548000. \text{ Nmm}$$

$$x_m = 12. \text{ mm}$$

$$u_m = -9. \text{ mm}$$

$$v_m = -34.93 \text{ mm}$$

$$\sigma_m = -Mv/J_u = -227.9 \text{ N/mm}^2$$

$$x_c = 21. \text{ mm}$$

$$y_c = 9. \text{ mm}$$

$$v_c = -25.93 \text{ mm}$$

$$\sigma_c = -Mv/J_u = -169.2 \text{ N/mm}^2$$

$$\tau_c = 4.763 \text{ N/mm}^2$$

$$\sigma_o = \sqrt{\sigma^2 + 3\tau^2} = 169.4 \text{ N/mm}^2$$

$$S = 3942. \text{ mm}^3$$

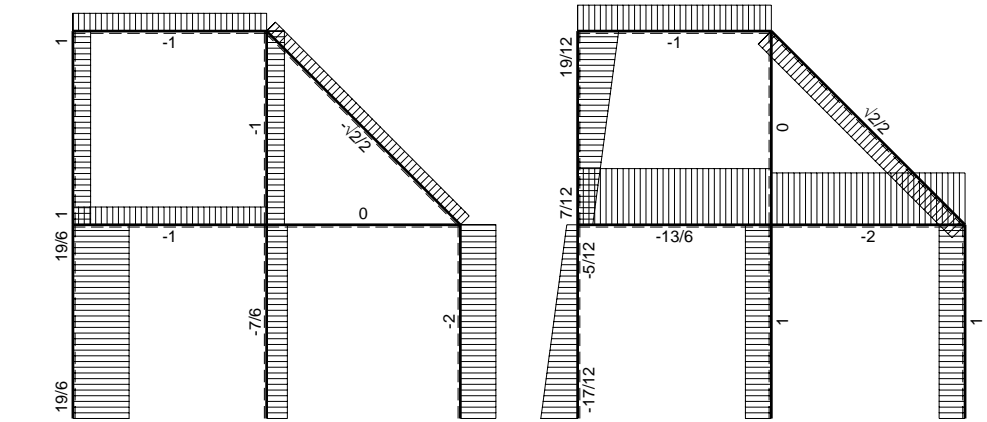
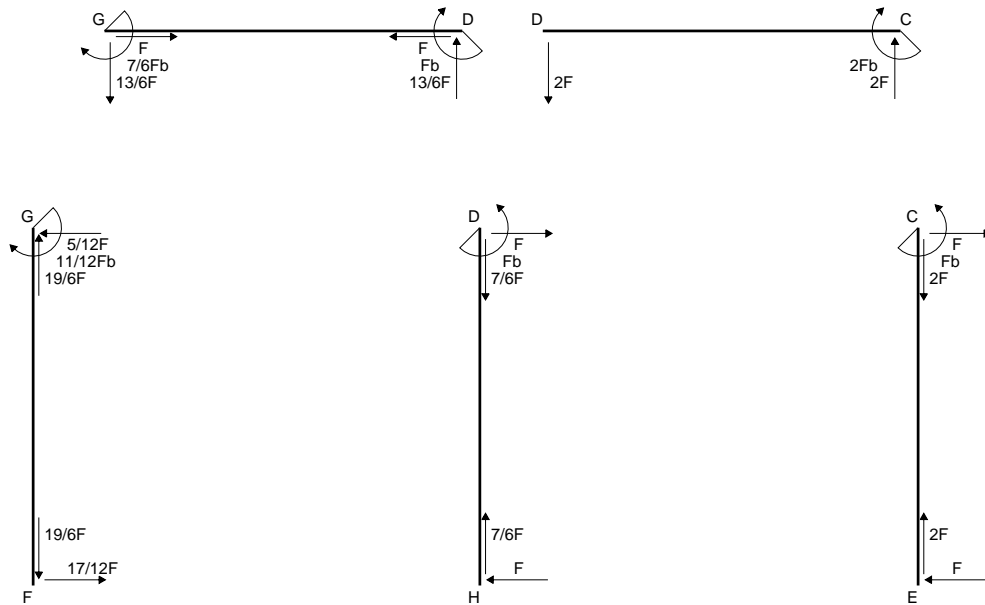
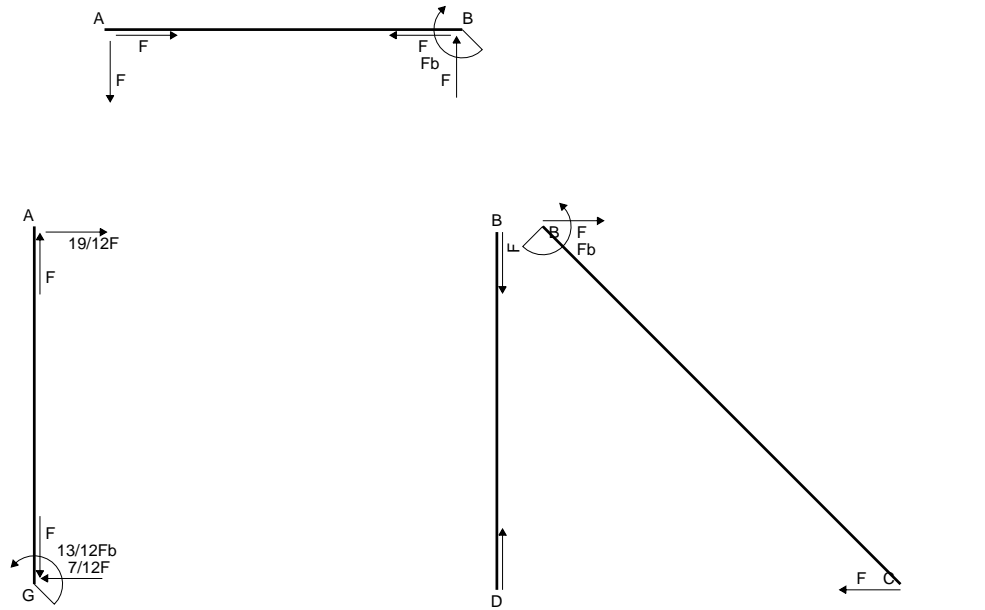

← ⊕ → F

↑ ⊕ ↓ F

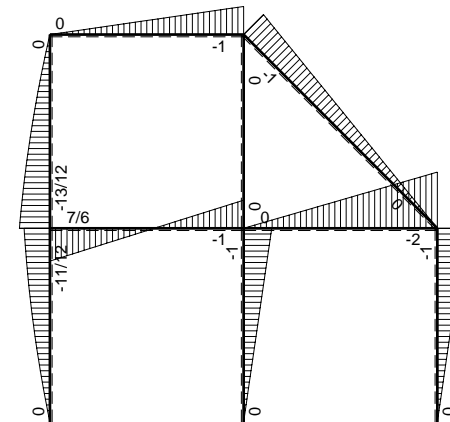

⊕ ⊖ Fb

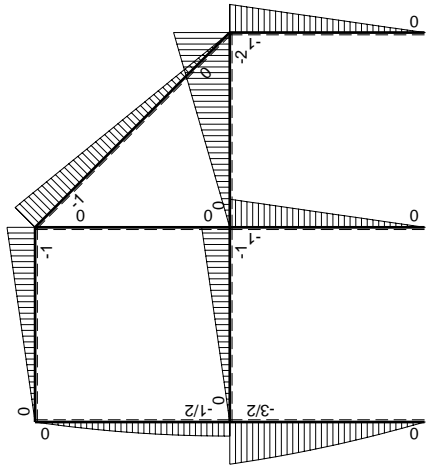
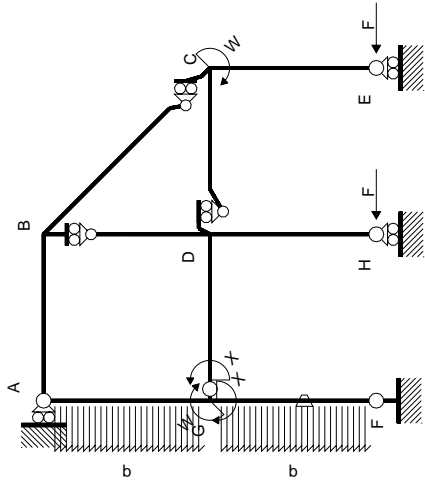

Schema di calcolo iperstatico

M_0 , flessione da carichi assegnati

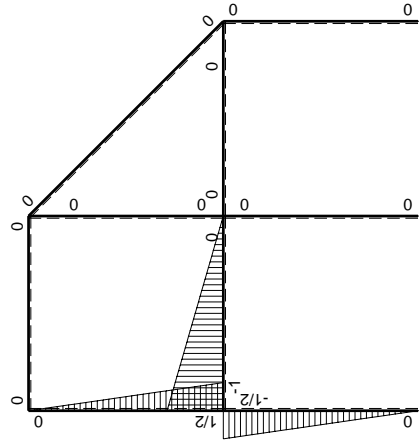

M_x , flessione da iperstatica $X=1$

Quadro contributi PLV per iperstatica $X=W_{GD}$

→	$M_x(x)$	$M_o(x)$	θ	$M_x M_o$	$M_x \theta$	$M_x M_x$	$\int M_x(M_o/EJ+\theta)dx$	$\int X M_x M_x/EJ dx$	
AB b	0	-Fx	0	0	0	0	0+0	0	
BA b	0	Fb-Fx	0	0	0	0	0	0	
BC $\sqrt{2}b$	0	-Fb+ $\sqrt{2}/2Fx$	0	0	0	0	0	0	
BD b	0	0	0	0	0	0	0+0	0	
DB b	0	0	0	0	0	0	0	0	
DC b	0	-2Fx	0	0	0	0	0+0	0	
CD b	0	2Fb-2Fx	0	0	0	0	0	0	
CE b	0	-Fb+Fx	0	0	0	0	0+0	0	
EC b	0	Fx	0	0	0	0	0	0	
FG b	-1/2x/b	-2Fx+1/2qx ²	-Fb/EJ	$Fx^2/b-1/4qx^3/b$	1/2Fx/EJ	$1/4x^2/b^2$	$(13/48+1/4)Fb^2/EJ$	1/12Xb/EJ	
GF b	1/2-1/2x/b	3/2Fb-Fx-1/2qx ²	Fb/EJ	$3/4Fb-5/4Fx+1/4Fx^2/b+1/4qx^3/b$	1/2Fb/EJ-1/2Fx/EJ	$1/4-1/2x/b+1/4x^2/b^2$			
GD b	-1+x/b	-Fx	0	$Fx-Fx^2/b$	0	$1-2x/b+x^2/b^2$	$(1/6+0)Fb^2/EJ$	1/3Xb/EJ	
DG b	x/b	Fb-Fx	0	$Fx-Fx^2/b$	0	x^2/b^2			
DH b	0	-Fb+Fx	0	0	0	0	0+0	0	
HD b	0	Fx	0	0	0	0			
GA b	1/2-1/2x/b	-1/2Fb+1/2qx ²	0	$-1/4Fb+1/4Fx+1/4Fx^2/b-1/4qx^3/b$	0	$1/4-1/2x/b+1/4x^2/b^2$	$(-5/48+0)Fb^2/EJ$	1/12Xb/EJ	
AG b	-1/2x/b	Fx-1/2qx ²	0	$-1/2Fx^2/b+1/4qx^3/b$	0	$1/4x^2/b^2$			
	totali							7/12Fb ² /EJ	1/2Xb/EJ
	iperstatica $X=W_{GD}$							-7/6Fb	

Sviluppi di calcolo iperstatica

$$L_{FG}^{xx} = \int_0^b (1/4 x^2/b^2) 1/EJ dx = [1/12 x^3/b^2]_0^b 1/EJ$$

$$= (1/12 b) 1/EJ = 1/12 b/EJ$$

$$L_{GF}^{xx} = \int_0^b (1/4 - 1/2 x/b + 1/4 x^2/b^2) 1/EJ dx = [1/4 x - 1/4 x^2/b + 1/12 x^3/b^2]_0^b 1/EJ$$

$$= (1/4 b - 1/4 b + 1/12 b) 1/EJ = 1/12 b/EJ$$

$$L_{GD}^{xx} = \int_0^b (1 - 2 x/b + x^2/b^2) 1/EJ dx = [x - x^2/b + 1/3 x^3/b^2]_0^b 1/EJ$$

$$= (b - b + 1/3 b) 1/EJ = 1/3 b/EJ$$

$$L_{DG}^{xx} = \int_0^b (x^2/b^2) 1/EJ dx = [1/3 x^3/b^2]_0^b 1/EJ$$

$$= (1/3 b) 1/EJ = 1/3 b/EJ$$

$$L_{GA}^{xx} = \int_0^b (1/4 - 1/2 x/b + 1/4 x^2/b^2) 1/EJ dx = [1/4 x - 1/4 x^2/b + 1/12 x^3/b^2]_0^b 1/EJ$$

$$= (1/4 b - 1/4 b + 1/12 b) 1/EJ = 1/12 b/EJ$$

$$L_{AG}^{xx} = \int_0^b (1/4 x^2/b^2) 1/EJ dx = [1/12 x^3/b^2]_0^b 1/EJ$$

$$= (1/12 b) 1/EJ = 1/12 b/EJ$$

$$L_{FG}^{xo} = \int_0^b (x^2/b^2 - 1/4 x^3/b^3) Fb 1/EJ dx + \int_0^b (1/2 x/b) \theta dx$$

$$= [1/3 x^3/b^2 - 1/16 x^4/b^3]_0^b Fb 1/EJ + [1/4 x^2/b]_0^b \theta$$

$$= (1/3 b - 1/16 b) Fb 1/EJ + (1/4 b) \theta = 25/48 Fb^2/EJ$$

$$L_{GF}^{xo} = \int_0^b (3/4 - 5/4 x/b + 1/4 x^2/b^2 + 1/4 x^3/b^3) Fb 1/EJ dx + \int_0^b (-1/2 + 1/2 x/b) \theta dx$$

$$= [3/4 x - 5/8 x^2/b + 1/12 x^3/b^2 + 1/16 x^4/b^3]_0^b Fb 1/EJ + [-1/2 x + 1/4 x^2/b]_0^b \theta$$

$$= (3/4 b - 5/8 b + 1/12 b + 1/16 b) Fb 1/EJ + (-1/2 b + 1/4 b) \theta = 25/48 Fb^2/EJ$$

$$L_{GD}^{xo} = \int_0^b (x/b - x^2/b^2) Fb 1/EJ dx = [1/2 x^2/b - 1/3 x^3/b^2]_0^b Fb 1/EJ$$

$$= (1/2 b - 1/3 b) Fb 1/EJ = 1/6 Fb^2/EJ$$

$$L_{DG}^{xo} = \int_0^b (x/b - x^2/b^2) Fb 1/EJ dx = [1/2 x^2/b - 1/3 x^3/b^2]_0^b Fb 1/EJ$$

$$= (1/2 b - 1/3 b) Fb 1/EJ = 1/6 Fb^2/EJ$$

$$L_{GA}^{xo} = \int_0^b (-1/4 + 1/4 x/b + 1/4 x^2/b^2 - 1/4 x^3/b^3) Fb 1/EJ dx$$

$$= [-1/4 x + 1/8 x^2/b + 1/12 x^3/b^2 - 1/16 x^4/b^3]_0^b Fb 1/EJ$$

$$= (-1/4 b + 1/8 b + 1/12 b - 1/16 b) Fb 1/EJ = -5/48 Fb^2/EJ$$

$$L_{AG}^{xo} = \int_0^b (-1/2 x^2/b^2 + 1/4 x^3/b^3) Fb 1/EJ dx = [-1/6 x^3/b^2 + 1/16 x^4/b^3]_0^b Fb 1/EJ$$

$$= (-1/6 b + 1/16 b) Fb 1/EJ = -5/48 Fb^2/EJ$$

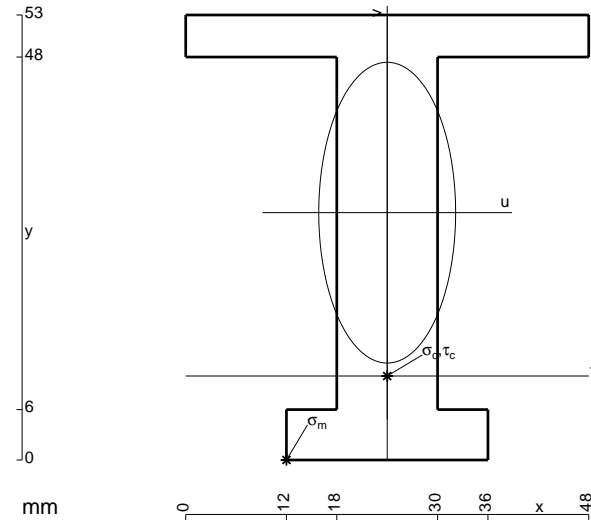

$$A = 888. \text{ mm}^2$$

$$J_u = 285133. \text{ mm}^4$$

$$J_v = 59040. \text{ mm}^4$$

$$y_g = 29.46 \text{ mm}$$

$$T_y = -2440. \text{ N}$$

$$M_x = -2318000. \text{ Nmm}$$

$$x_m = 12. \text{ mm}$$

$$u_m = -12. \text{ mm}$$

$$v_m = -29.46 \text{ mm}$$

$$\sigma_m = -Mv/J_u = -239.5 \text{ N/mm}^2$$

$$x_c = 24. \text{ mm}$$

$$y_c = 10. \text{ mm}$$

$$v_c = -19.46 \text{ mm}$$

$$\sigma_c = -Mv/J_u = -158.2 \text{ N/mm}^2$$

$$\tau_c = 3.452 \text{ N/mm}^2$$

$$\sigma_q = \sqrt{\sigma^2 + 3\tau^2} = 158.3 \text{ N/mm}^2$$

$$S = 4840. \text{ mm}^3$$

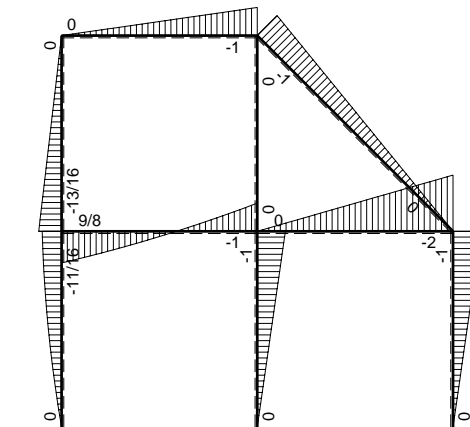
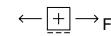
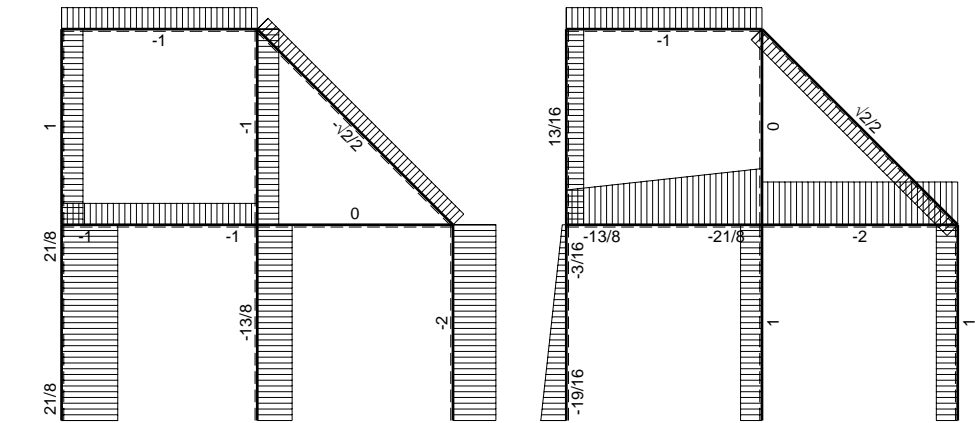
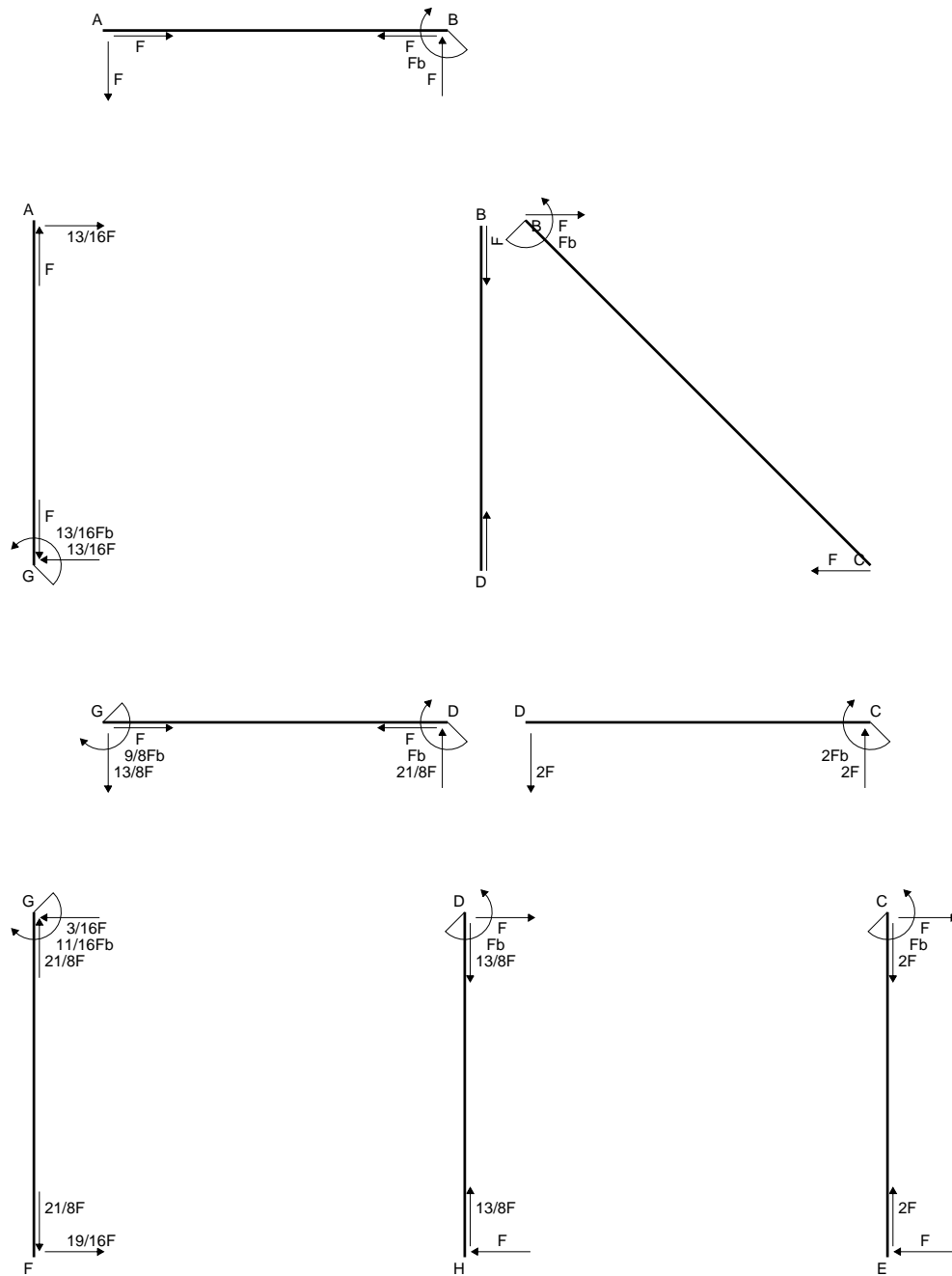

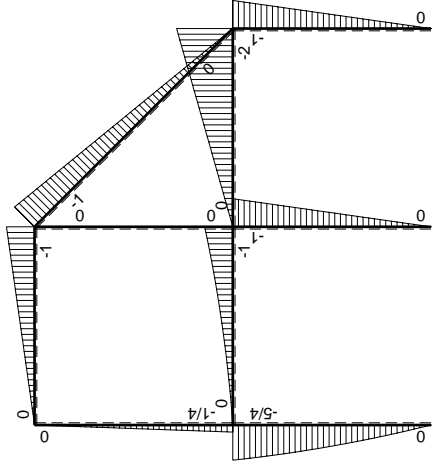
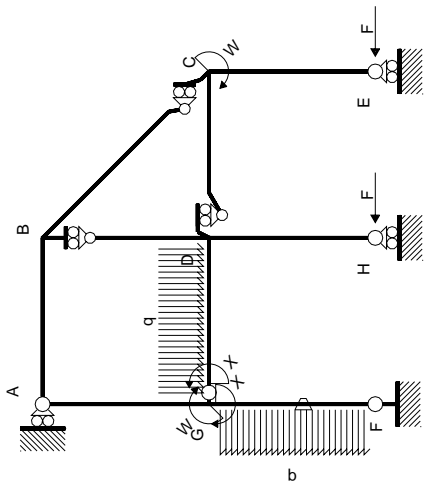

Schema di calcolo iperstatico

M_0 flessione da carichi assegnati

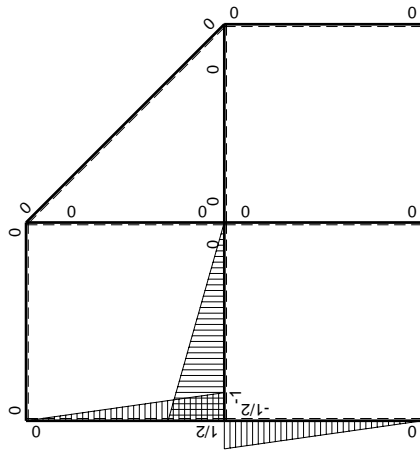

M_x flessione da iperstatica $X=1$

Quadro contributi PLV per iperstatica $X=W_{GD}$

→	$M_x(x)$	$M_o(x)$	θ	$M_x M_o$	$M_x \theta$	$M_x M_x$	$\int M_x(M_o/EJ+\theta)dx$	$\int X M_x M_x/EJdx$
AB b	0	-Fx	0	0	0	0	0+0	0
BA b	0	Fb-Fx	0	0	0	0	0	0
BC $\sqrt{2}b$	0	-Fb+ $\sqrt{2}/2Fx$	0	0	0	0	0	0
BD b	0	0	0	0	0	0	0+0	0
DB b	0	0	0	0	0	0	0	0
DC b	0	-2Fx	0	0	0	0	0+0	0
CD b	0	2Fb-2Fx	0	0	0	0	0	0
CE b	0	-Fb+Fx	0	0	0	0	0+0	0
EC b	0	Fx	0	0	0	0	0	0
FG b	-1/2x/b	-7/4Fx+1/2qx ²	-Fb/EJ	7/8Fx ² /b-1/4qx ³ /b	1/2Fx/EJ	1/4x ² /b ²	(11/48+1/4)Fb ² /EJ	1/12Xb/EJ
GF b	1/2-1/2x/b	5/4Fb-3/4Fx-1/2qx ²	Fb/EJ	5/8Fb-Fx+1/8Fx ² /b+1/4qx ³ /b	1/2Fb/EJ-1/2Fx/EJ	1/4-1/2x/b+1/4x ² /b ²		
GD b	-1+x/b	-1/2Fx-1/2qx ²	0	1/2Fx-1/2qx ³ /b	0	1-2x/b+x ² /b ²	(1/8+0)Fb ² /EJ	1/3Xb/EJ
DG b	x/b	Fb-3/2Fx+1/2qx ²	0	Fx-3/2Fx ² /b+1/2qx ³ /b	0	x ² /b ²		
DH b	0	-Fb+Fx	0	0	0	0	0+0	0
HD b	0	Fx	0	0	0	0	0	0
GA b	1/2-1/2x/b	-1/4Fb+1/4Fx	0	-1/8Fb+1/4Fx-1/8Fx ² /b	0	1/4-1/2x/b+1/4x ² /b ²	(-1/24+0)Fb ² /EJ	1/12Xb/EJ
AG b	-1/2x/b	1/4Fx	0	-1/8Fx ² /b	0	1/4x ² /b ²		
	totali						9/16Fb ² /EJ	1/2Xb/EJ
	iperstatica $X=W_{GD}$						-9/8Fb	

Sviluppi di calcolo iperstatica

$$L_{FG}^{xx} = \int_0^b (1/4 x^2/b^2) 1/EJ dx = [1/12 x^3/b^2]_0^b 1/EJ$$

$$= (1/12 b) 1/EJ = 1/12 b/EJ$$

$$L_{GF}^{xx} = \int_0^b (1/4 - 1/2 x/b + 1/4 x^2/b^2) 1/EJ dx = [1/4 x - 1/4 x^2/b + 1/12 x^3/b^2]_0^b 1/EJ$$

$$= (1/4 b - 1/4 b + 1/12 b) 1/EJ = 1/12 b/EJ$$

$$L_{GD}^{xx} = \int_0^b (1 - 2 x/b + x^2/b^2) 1/EJ dx = [x - x^2/b + 1/3 x^3/b^2]_0^b 1/EJ$$

$$= (b - b + 1/3 b) 1/EJ = 1/3 b/EJ$$

$$L_{DG}^{xx} = \int_0^b (x^2/b^2) 1/EJ dx = [1/3 x^3/b^2]_0^b 1/EJ$$

$$= (1/3 b) 1/EJ = 1/3 b/EJ$$

$$L_{GA}^{xx} = \int_0^b (1/4 - 1/2 x/b + 1/4 x^2/b^2) 1/EJ dx = [1/4 x - 1/4 x^2/b + 1/12 x^3/b^2]_0^b 1/EJ$$

$$= (1/4 b - 1/4 b + 1/12 b) 1/EJ = 1/12 b/EJ$$

$$L_{AG}^{xx} = \int_0^b (1/4 x^2/b^2) 1/EJ dx = [1/12 x^3/b^2]_0^b 1/EJ$$

$$= (1/12 b) 1/EJ = 1/12 b/EJ$$

$$L_{FG}^{xo} = \int_0^b (7/8 x^2/b^2 - 1/4 x^3/b^3) Fb 1/EJ dx + \int_0^b (1/2 x/b) \theta dx$$

$$= [7/24 x^3/b^2 - 1/16 x^4/b^3]_0^b Fb 1/EJ + [1/4 x^2/b]_0^b \theta$$

$$= (7/24 b - 1/16 b) Fb 1/EJ + (1/4 b) \theta = 23/48 Fb^2/EJ$$

$$L_{GF}^{xo} = \int_0^b (5/8 - x/b + 1/8 x^2/b^2 + 1/4 x^3/b^3) Fb 1/EJ dx + \int_0^b (-1/2 + 1/2 x/b) \theta dx$$

$$= [5/8 x - 1/2 x^2/b + 1/24 x^3/b^2 + 1/16 x^4/b^3]_0^b Fb 1/EJ + [-1/2 x + 1/4 x^2/b]_0^b \theta$$

$$= (5/8 b - 1/2 b + 1/24 b + 1/16 b) Fb 1/EJ + (-1/2 b + 1/4 b) \theta = 23/48 Fb^2/EJ$$

$$L_{GD}^{xo} = \int_0^b (1/2 x/b - 1/2 x^3/b^3) Fb 1/EJ dx = [1/4 x^2/b - 1/8 x^4/b^3]_0^b Fb 1/EJ$$

$$= (1/4 b - 1/8 b) Fb 1/EJ = 1/8 Fb^2/EJ$$

$$L_{DG}^{xo} = \int_0^b (x/b - 3/2 x^2/b^2 + 1/2 x^3/b^3) Fb 1/EJ dx = [1/2 x^2/b - 1/2 x^3/b^2 + 1/8 x^4/b^3]_0^b Fb 1/EJ$$

$$= (1/2 b - 1/2 b + 1/8 b) Fb 1/EJ = 1/8 Fb^2/EJ$$

$$L_{GA}^{xo} = \int_0^b (-1/8 + 1/4 x/b - 1/8 x^2/b^2) Fb 1/EJ dx = [-1/8 x + 1/8 x^2/b - 1/24 x^3/b^2]_0^b Fb 1/EJ$$

$$= (-1/8 b + 1/8 b - 1/24 b) Fb 1/EJ = -1/24 Fb^2/EJ$$

$$L_{AG}^{xo} = \int_0^b (-1/8 x^2/b^2) Fb 1/EJ dx = [-1/24 x^3/b^2]_0^b Fb 1/EJ$$

$$= (-1/24 b) Fb 1/EJ = -1/24 Fb^2/EJ$$

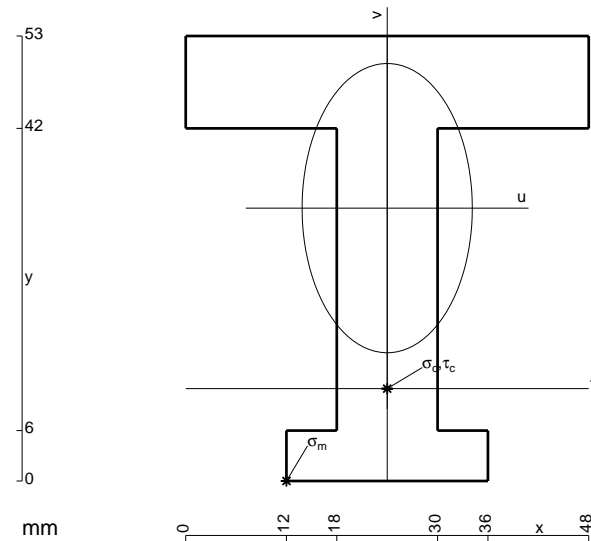

$$A = 1104. \text{ mm}^2$$

$$J_u = 327740. \text{ mm}^4$$

$$J_v = 113472. \text{ mm}^4$$

$$y_g = 32.5 \text{ mm}$$

$$T_y = -4020. \text{ N}$$

$$M_x = -2010000. \text{ Nmm}$$

$$x_m = 12. \text{ mm}$$

$$u_m = -12. \text{ mm}$$

$$v_m = -32.5 \text{ mm}$$

$$\sigma_m = -Mv/J_u = -199.3 \text{ N/mm}^2$$

$$x_c = 24. \text{ mm}$$

$$y_c = 11. \text{ mm}$$

$$v_c = -21.5 \text{ mm}$$

$$\sigma_c = -Mv/J_u = -131.9 \text{ N/mm}^2$$

$$\tau_c = 5.814 \text{ N/mm}^2$$

$$\sigma_q = \sqrt{\sigma^2 + 3\tau^2} = 132.2 \text{ N/mm}^2$$

$$S = 5688. \text{ mm}^3$$

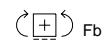
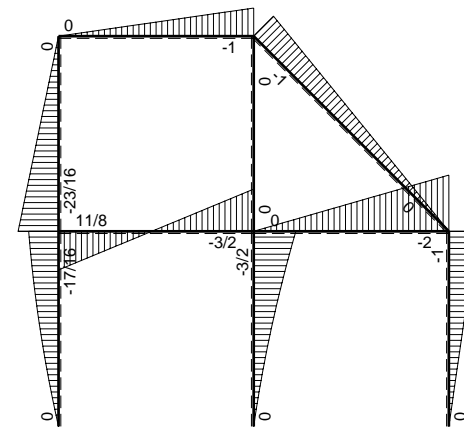
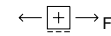
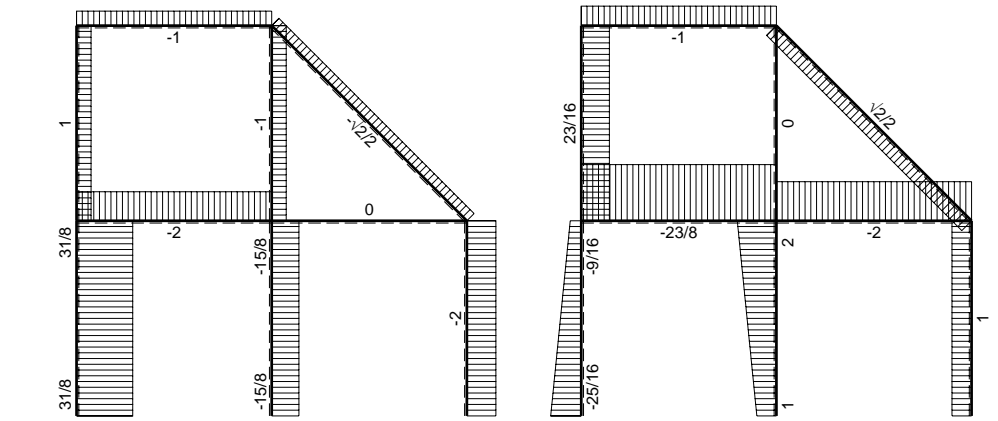
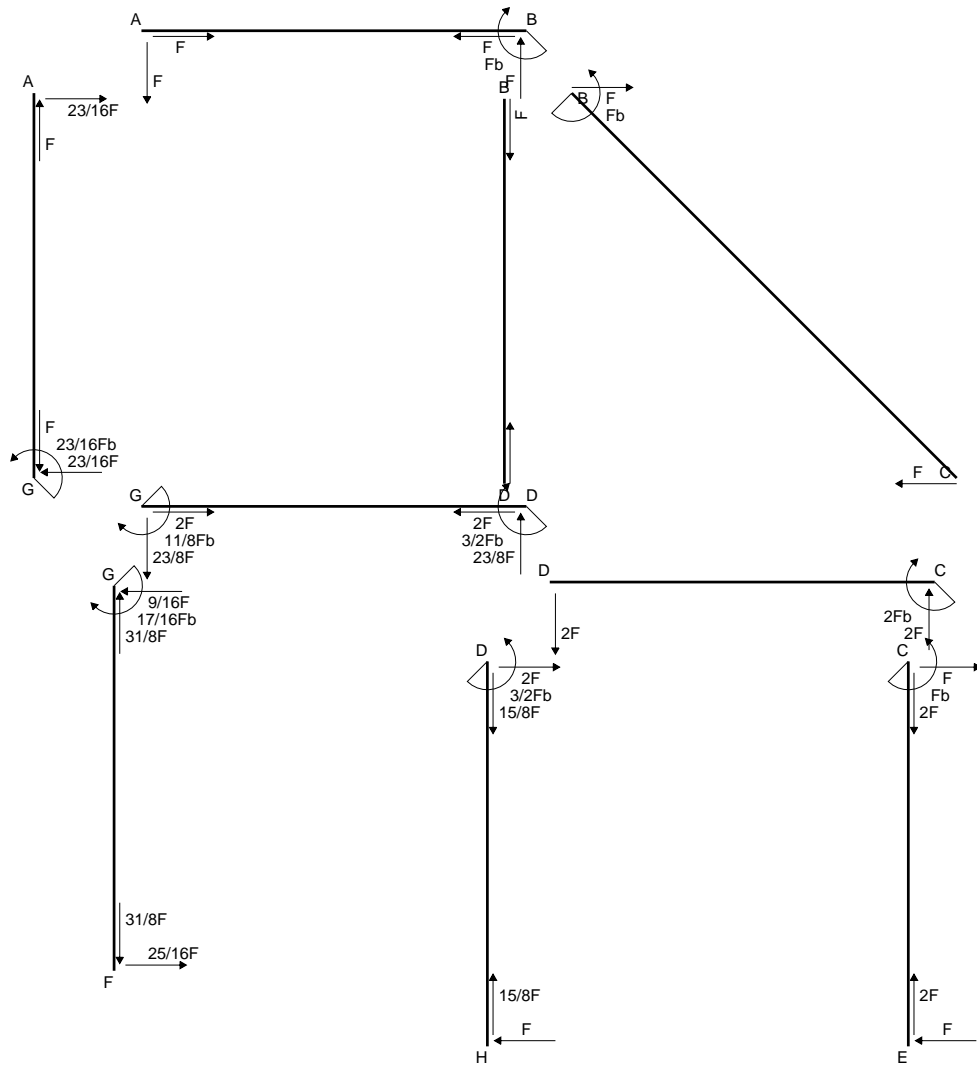

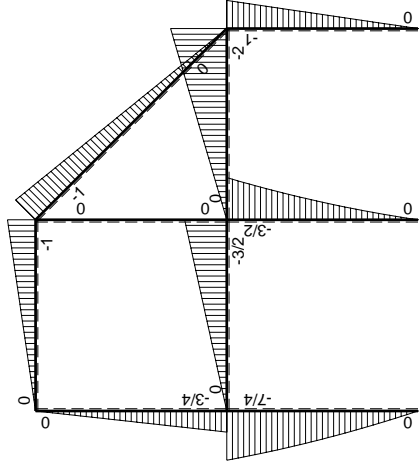
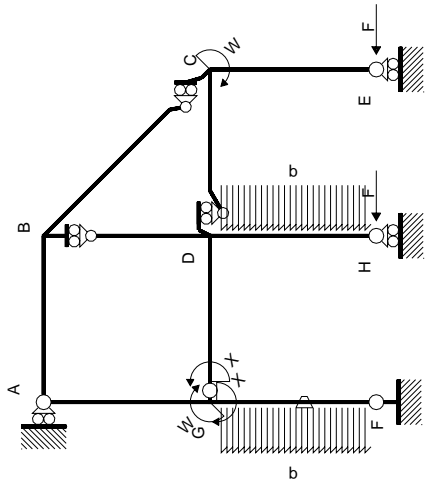

Schema di calcolo iperstatico

M_0 flessione da carichi assegnati

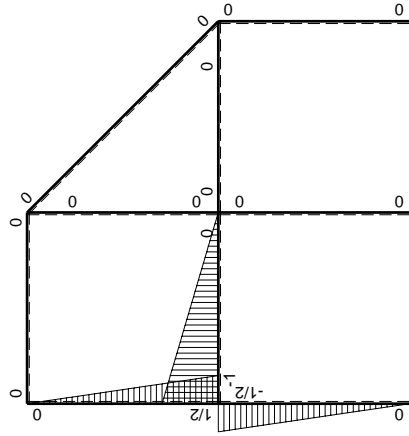

M_x flessione da iperstatica $X=1$

Quadro contributi PLV per iperstatica $X=W_{GD}$

→	$M_x(x)$	$M_o(x)$	θ	$M_x M_o$	$M_x \theta$	$M_x M_x$	$\int M_x(M_o/EJ+\theta)dx$	$\int X M_x M_x/EJdx$
AB b	0	-Fx	0	0	0	0	0+0	0
BA b	0	Fb-Fx	0	0	0	0	0	0
BC $\sqrt{2}b$	0	-Fb+ $\sqrt{2}/2Fx$	0	0	0	0	0	0
BD b	0	0	0	0	0	0	0+0	0
DB b	0	0	0	0	0	0	0	0
DC b	0	-2Fx	0	0	0	0	0+0	0
CD b	0	2Fb-2Fx	0	0	0	0	0	0
CE b	0	-Fb+Fx	0	0	0	0	0+0	0
EC b	0	Fx	0	0	0	0	0	0
FG b	-1/2x/b	-9/4Fx+1/2qx ²	-Fb/EJ	9/8Fx ² /b-1/4qx ³ /b	1/2Fx/EJ	1/4x ² /b ²	(5/16+1/4)Fb ² /EJ	1/12Xb/EJ
GF b	1/2-1/2x/b	7/4Fb-5/4Fx-1/2qx ²	Fb/EJ	7/8Fb-3/2Fx+3/8Fx ² /b+1/4qx ³ /b	1/2Fb/EJ-1/2Fx/EJ	1/4-1/2x/b+1/4x ² /b ²		
GD b	-1+x/b	-3/2Fx	0	3/2Fx-3/2Fx ² /b	0	1-2x/b+x ² /b ²	(1/4+0)Fb ² /EJ	1/3Xb/EJ
DG b	x/b	3/2Fb-3/2Fx	0	3/2Fx-3/2Fx ² /b	0	x ² /b ²		
DH b	0	-3/2Fb+2Fx-1/2qx ²	0	0	0	0	0+0	0
HD b	0	Fx+1/2qx ²	0	0	0	0		
GA b	1/2-1/2x/b	-3/4Fb+3/4Fx	0	-3/8Fb+3/4Fx-3/8Fx ² /b	0	1/4-1/2x/b+1/4x ² /b ²	(-1/8+0)Fb ² /EJ	1/12Xb/EJ
AG b	-1/2x/b	3/4Fx	0	-3/8Fx ² /b	0	1/4x ² /b ²		
	totali						11/16Fb ² /EJ	1/2Xb/EJ
	iperstatica $X=W_{GD}$						-11/8Fb	

Sviluppi di calcolo iperstatica

$$L_{FG}^{xx} = \int_0^b (1/4 x^2/b^2) 1/EJ dx = [1/12 x^3/b^2]_0^b 1/EJ$$

$$= (1/12 b) 1/EJ = 1/12 b/EJ$$

$$L_{GF}^{xx} = \int_0^b (1/4 - 1/2 x/b + 1/4 x^2/b^2) 1/EJ dx = [1/4 x - 1/4 x^2/b + 1/12 x^3/b^2]_0^b 1/EJ$$

$$= (1/4 b - 1/4 b + 1/12 b) 1/EJ = 1/12 b/EJ$$

$$L_{GD}^{xx} = \int_0^b (1 - 2 x/b + x^2/b^2) 1/EJ dx = [x - x^2/b + 1/3 x^3/b^2]_0^b 1/EJ$$

$$= (b - b + 1/3 b) 1/EJ = 1/3 b/EJ$$

$$L_{DG}^{xx} = \int_0^b (x^2/b^2) 1/EJ dx = [1/3 x^3/b^2]_0^b 1/EJ$$

$$= (1/3 b) 1/EJ = 1/3 b/EJ$$

$$L_{GA}^{xx} = \int_0^b (1/4 - 1/2 x/b + 1/4 x^2/b^2) 1/EJ dx = [1/4 x - 1/4 x^2/b + 1/12 x^3/b^2]_0^b 1/EJ$$

$$= (1/4 b - 1/4 b + 1/12 b) 1/EJ = 1/12 b/EJ$$

$$L_{AG}^{xx} = \int_0^b (1/4 x^2/b^2) 1/EJ dx = [1/12 x^3/b^2]_0^b 1/EJ$$

$$= (1/12 b) 1/EJ = 1/12 b/EJ$$

$$L_{FG}^{x_0} = \int_0^b (9/8 x^2/b^2 - 1/4 x^3/b^3) Fb 1/EJ dx + \int_0^b (1/2 x/b) \theta dx$$

$$= [3/8 x^3/b^2 - 1/16 x^4/b^3]_0^b Fb 1/EJ + [1/4 x^2/b]_0^b \theta$$

$$= (3/8 b - 1/16 b) Fb 1/EJ + (1/4 b) \theta = 9/16 Fb^2/EJ$$

$$L_{GF}^{x_0} = \int_0^b (7/8 - 3/2 x/b + 3/8 x^2/b^2 + 1/4 x^3/b^3) Fb 1/EJ dx + \int_0^b (-1/2 + 1/2 x/b) \theta dx$$

$$= [7/8 x - 3/4 x^2/b + 1/8 x^3/b^2 + 1/16 x^4/b^3]_0^b Fb 1/EJ + [-1/2 x + 1/4 x^2/b]_0^b \theta$$

$$= (7/8 b - 3/4 b + 1/8 b + 1/16 b) Fb 1/EJ + (-1/2 b + 1/4 b) \theta = 9/16 Fb^2/EJ$$

$$L_{GD}^{x_0} = \int_0^b (3/2 x/b - 3/2 x^2/b^2) Fb 1/EJ dx = [3/4 x^2/b - 1/2 x^3/b^2]_0^b Fb 1/EJ$$

$$= (3/4 b - 1/2 b) Fb 1/EJ = 1/4 Fb^2/EJ$$

$$L_{DG}^{x_0} = \int_0^b (3/2 x/b - 3/2 x^2/b^2) Fb 1/EJ dx = [3/4 x^2/b - 1/2 x^3/b^2]_0^b Fb 1/EJ$$

$$= (3/4 b - 1/2 b) Fb 1/EJ = 1/4 Fb^2/EJ$$

$$L_{GA}^{x_0} = \int_0^b (-3/8 + 3/4 x/b - 3/8 x^2/b^2) Fb 1/EJ dx = [-3/8 x + 3/8 x^2/b - 1/8 x^3/b^2]_0^b Fb 1/EJ$$

$$= (-3/8 b + 3/8 b - 1/8 b) Fb 1/EJ = -1/8 Fb^2/EJ$$

$$L_{AG}^{x_0} = \int_0^b (-3/8 x^2/b^2) Fb 1/EJ dx = [-1/8 x^3/b^2]_0^b Fb 1/EJ$$

$$= (-1/8 b) Fb 1/EJ = -1/8 Fb^2/EJ$$

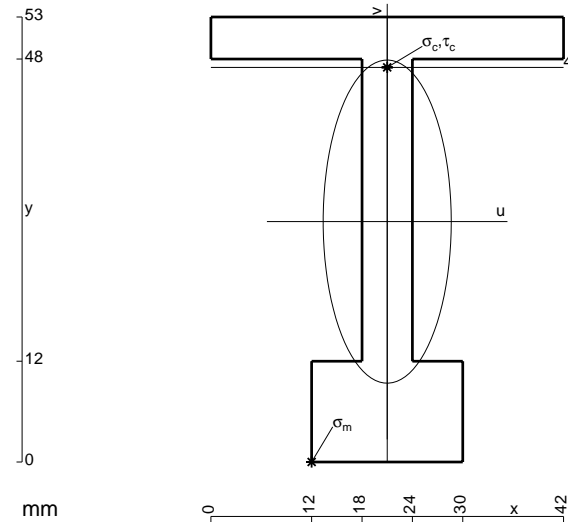

$$A = 642. \text{ mm}^2$$

$$J_u = 237823. \text{ mm}^4$$

$$J_v = 37350. \text{ mm}^4$$

$$y_g = 28.63 \text{ mm}$$

$$T_y = -3160. \text{ N}$$

$$M_x = -1738000. \text{ Nmm}$$

$$x_m = 12. \text{ mm}$$

$$u_m = -9. \text{ mm}$$

$$v_m = -28.63 \text{ mm}$$

$$\sigma_m = -Mv/J_u = -209.2 \text{ N/mm}^2$$

$$x_c = 21. \text{ mm}$$

$$y_c = 47. \text{ mm}$$

$$v_c = 18.37 \text{ mm}$$

$$\sigma_c = -Mv/J_u = 134.2 \text{ N/mm}^2$$

$$\tau_c = 10.42 \text{ N/mm}^2$$

$$\sigma_q = \sqrt{\sigma^2 + 3\tau^2} = 135.4 \text{ N/mm}^2$$

$$S = 4706. \text{ mm}^3$$

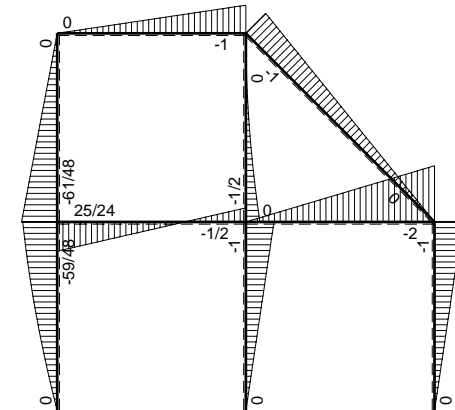
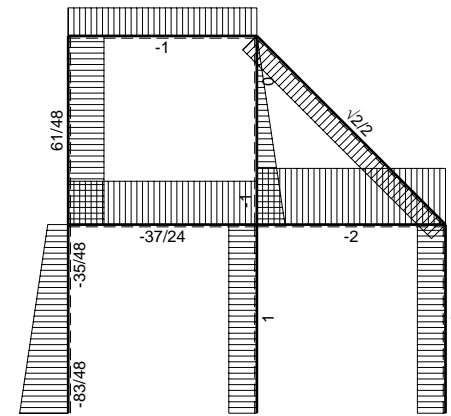
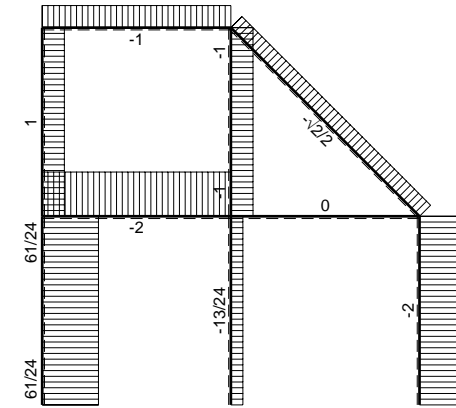
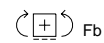
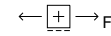
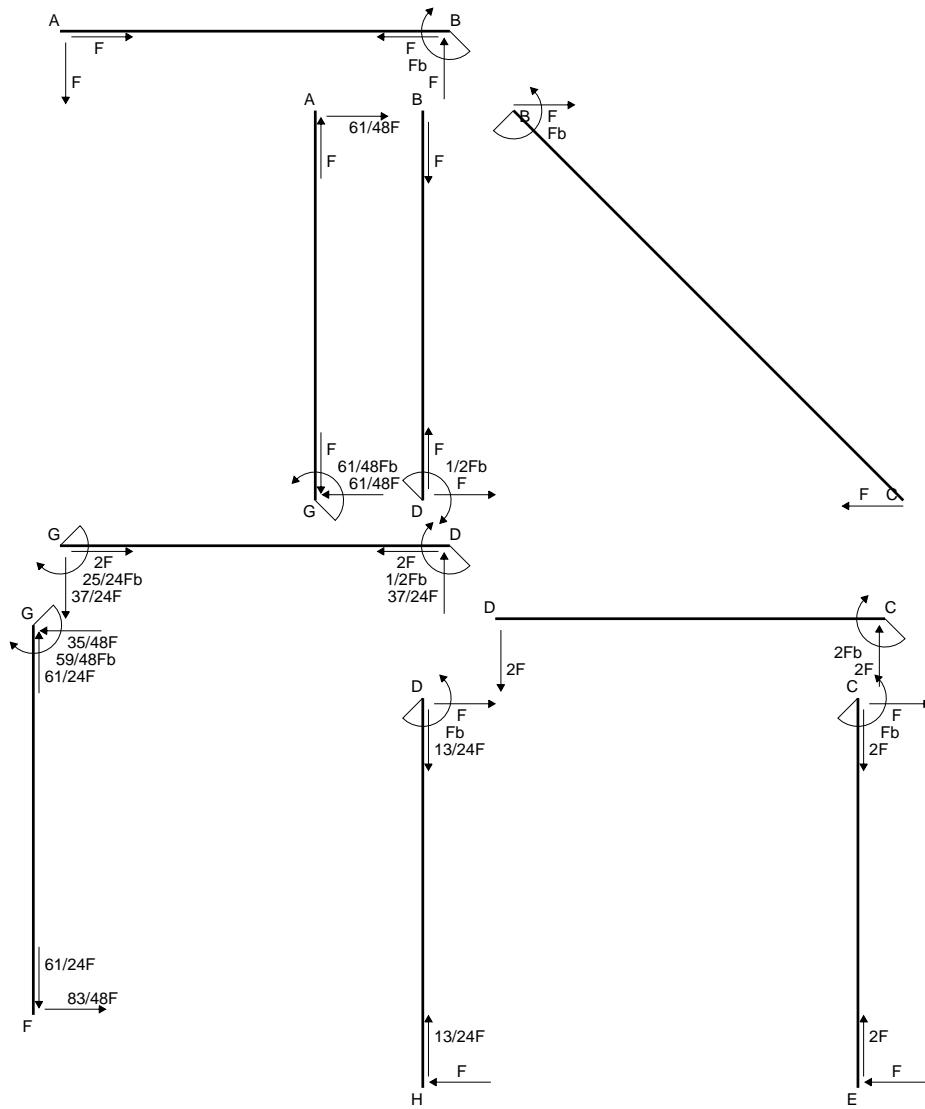

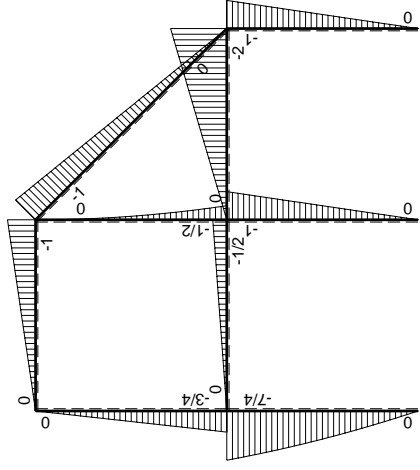
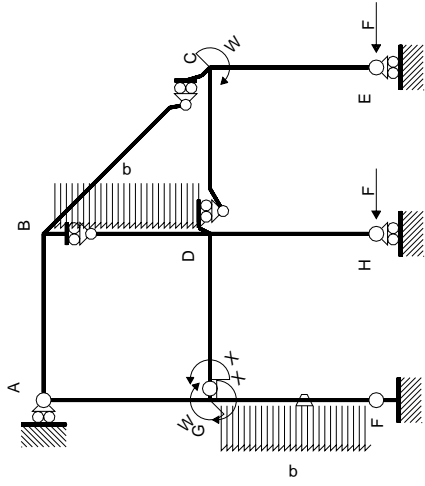

Schema di calcolo iperstatico

M_0 flessione da carichi assegnati

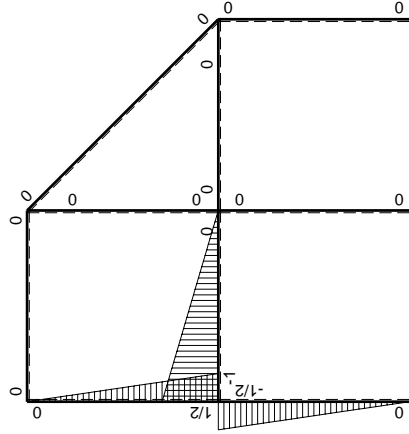

M_x flessione da iperstatica $X=1$

Quadro contributi PLV per iperstatica $X=W_{GD}$

→	$M_x(x)$	$M_o(x)$	θ	$M_x M_o$	$M_x \theta$	$M_x M_x$	$\int M_x(M_o/EJ+\theta)dx$	$\int X M_x M_x/EJdx$
AB b	0	-Fx	0	0	0	0	0+0	0
BA b	0	Fb-Fx	0	0	0	0	0	0
BC $\sqrt{2}b$	0	-Fb+ $\sqrt{2}/2Fx$	0	0	0	0	0	0
BD b	0	-1/2qx ²	0	0	0	0	0+0	0
DB b	0	1/2Fb-Fx+1/2qx ²	0	0	0	0	0	0
DC b	0	-2Fx	0	0	0	0	0+0	0
CD b	0	2Fb-2Fx	0	0	0	0	0	0
CE b	0	-Fb+Fx	0	0	0	0	0+0	0
EC b	0	Fx	0	0	0	0	0	0
FG b	-1/2x/b	-9/4Fx+1/2qx ²	-Fb/EJ	9/8Fx ² /b-1/4qx ³ /b	1/2Fx/EJ	1/4x ² /b ²	(5/16+1/4)Fb ² /EJ	1/12Xb/EJ
GF b	1/2-1/2x/b	7/4Fb-5/4Fx-1/2qx ²	Fb/EJ	7/8Fb-3/2Fx+3/8Fx ² /b+1/4qx ³ /b	1/2Fb/EJ-1/2Fx/EJ	1/4-1/2x/b+1/4x ² /b ²		
GD b	-1+x/b	-1/2Fx	0	1/2Fx-1/2Fx ² /b	0	1-2x/b+x ² /b ²	(1/12+0)Fb ² /EJ	1/3Xb/EJ
DG b	x/b	1/2Fb-1/2Fx	0	1/2Fx-1/2Fx ² /b	0	x ² /b ²		
DH b	0	-Fb+Fx	0	0	0	0	0+0	0
HD b	0	Fx	0	0	0	0	0	0
GA b	1/2-1/2x/b	-3/4Fb+3/4Fx	0	-3/8Fb+3/4Fx-3/8Fx ² /b	0	1/4-1/2x/b+1/4x ² /b ²	(-1/8+0)Fb ² /EJ	1/12Xb/EJ
AG b	-1/2x/b	3/4Fx	0	-3/8Fx ² /b	0	1/4x ² /b ²		
	totali						25/48Fb ² /EJ	1/2Xb/EJ
	iperstatica $X=W_{GD}$						-25/24Fb	

Sviluppi di calcolo iperstatica

$$L_{FG}^{xx} = \int_0^b (1/4 x^2/b^2) 1/EJ dx = [1/12 x^3/b^2]_0^b 1/EJ$$

$$= (1/12 b) 1/EJ = 1/12 b/EJ$$

$$L_{GF}^{xx} = \int_0^b (1/4 - 1/2 x/b + 1/4 x^2/b^2) 1/EJ dx = [1/4 x - 1/4 x^2/b + 1/12 x^3/b^2]_0^b 1/EJ$$

$$= (1/4 b - 1/4 b + 1/12 b) 1/EJ = 1/12 b/EJ$$

$$L_{GD}^{xx} = \int_0^b (1 - 2 x/b + x^2/b^2) 1/EJ dx = [x - x^2/b + 1/3 x^3/b^2]_0^b 1/EJ$$

$$= (b - b + 1/3 b) 1/EJ = 1/3 b/EJ$$

$$L_{DG}^{xx} = \int_0^b (x^2/b^2) 1/EJ dx = [1/3 x^3/b^2]_0^b 1/EJ$$

$$= (1/3 b) 1/EJ = 1/3 b/EJ$$

$$L_{GA}^{xx} = \int_0^b (1/4 - 1/2 x/b + 1/4 x^2/b^2) 1/EJ dx = [1/4 x - 1/4 x^2/b + 1/12 x^3/b^2]_0^b 1/EJ$$

$$= (1/4 b - 1/4 b + 1/12 b) 1/EJ = 1/12 b/EJ$$

$$L_{AG}^{xx} = \int_0^b (1/4 x^2/b^2) 1/EJ dx = [1/12 x^3/b^2]_0^b 1/EJ$$

$$= (1/12 b) 1/EJ = 1/12 b/EJ$$

$$L_{FG}^{xo} = \int_0^b (9/8 x^2/b^2 - 1/4 x^3/b^3) Fb 1/EJ dx + \int_0^b (1/2 x/b) \theta dx$$

$$= [3/8 x^3/b^2 - 1/16 x^4/b^3]_0^b Fb 1/EJ + [1/4 x^2/b]_0^b \theta$$

$$= (3/8 b - 1/16 b) Fb 1/EJ + (1/4 b) \theta = 9/16 Fb^2/EJ$$

$$L_{GF}^{xo} = \int_0^b (7/8 - 3/2 x/b + 3/8 x^2/b^2 + 1/4 x^3/b^3) Fb 1/EJ dx + \int_0^b (-1/2 + 1/2 x/b) \theta dx$$

$$= [7/8 x - 3/4 x^2/b + 1/8 x^3/b^2 + 1/16 x^4/b^3]_0^b Fb 1/EJ + [-1/2 x + 1/4 x^2/b]_0^b \theta$$

$$= (7/8 b - 3/4 b + 1/8 b + 1/16 b) Fb 1/EJ + (-1/2 b + 1/4 b) \theta = 9/16 Fb^2/EJ$$

$$L_{GD}^{xo} = \int_0^b (1/2 x/b - 1/2 x^2/b^2) Fb 1/EJ dx = [1/4 x^2/b - 1/6 x^3/b^2]_0^b Fb 1/EJ$$

$$= (1/4 b - 1/6 b) Fb 1/EJ = 1/12 Fb^2/EJ$$

$$L_{DG}^{xo} = \int_0^b (1/2 x/b - 1/2 x^2/b^2) Fb 1/EJ dx = [1/4 x^2/b - 1/6 x^3/b^2]_0^b Fb 1/EJ$$

$$= (1/4 b - 1/6 b) Fb 1/EJ = 1/12 Fb^2/EJ$$

$$L_{GA}^{xo} = \int_0^b (-3/8 + 3/4 x/b - 3/8 x^2/b^2) Fb 1/EJ dx = [-3/8 x + 3/8 x^2/b - 1/8 x^3/b^2]_0^b Fb 1/EJ$$

$$= (-3/8 b + 3/8 b - 1/8 b) Fb 1/EJ = -1/8 Fb^2/EJ$$

$$L_{AG}^{xo} = \int_0^b (-3/8 x^2/b^2) Fb 1/EJ dx = [-1/8 x^3/b^2]_0^b Fb 1/EJ$$

$$= (-1/8 b) Fb 1/EJ = -1/8 Fb^2/EJ$$

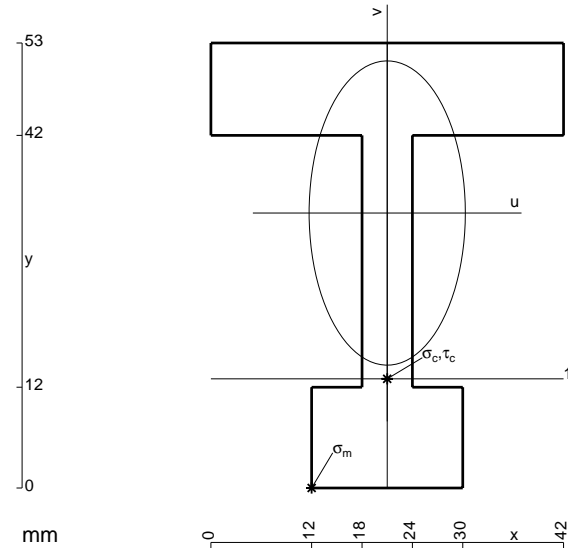

- A = 858. mm²
- J_u = 281777. mm⁴
- J_v = 74286. mm⁴
- y_g = 32.75 mm
- T_y = -3140. N
- M_x = -1884000. Nmm
- x_m = 12. mm
- u_m = -9. mm
- v_m = -32.75 mm
- σ_m = -Mv/J_u = -219. N/mm²
- x_c = 21. mm
- y_c = 13. mm
- v_c = -19.75 mm
- σ_c = -Mv/J_v = -132.1 N/mm²
- τ_c = 10.96 N/mm²
- σ_q = √σ²+3τ² = 133.4 N/mm²
- S = 5900. mm³

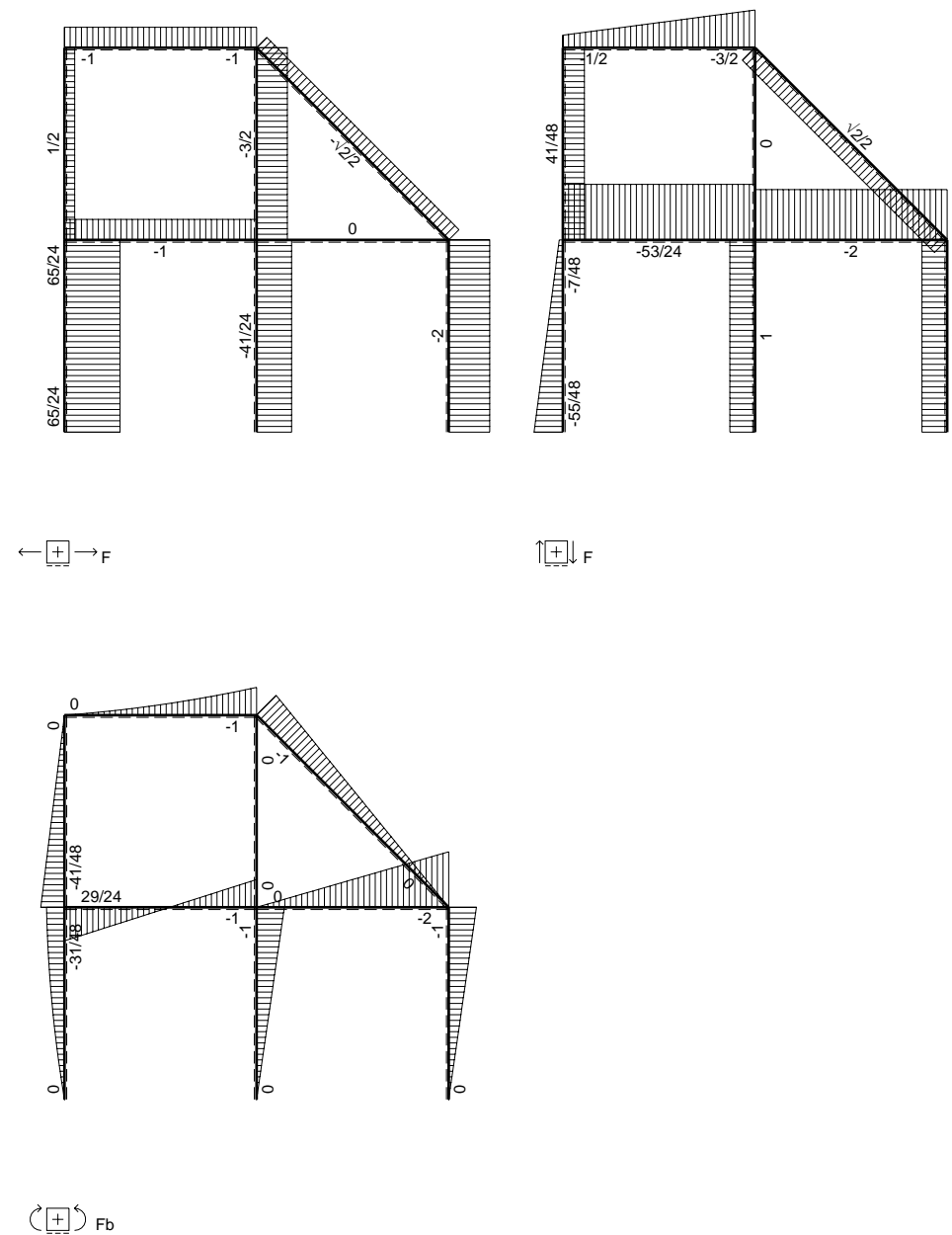
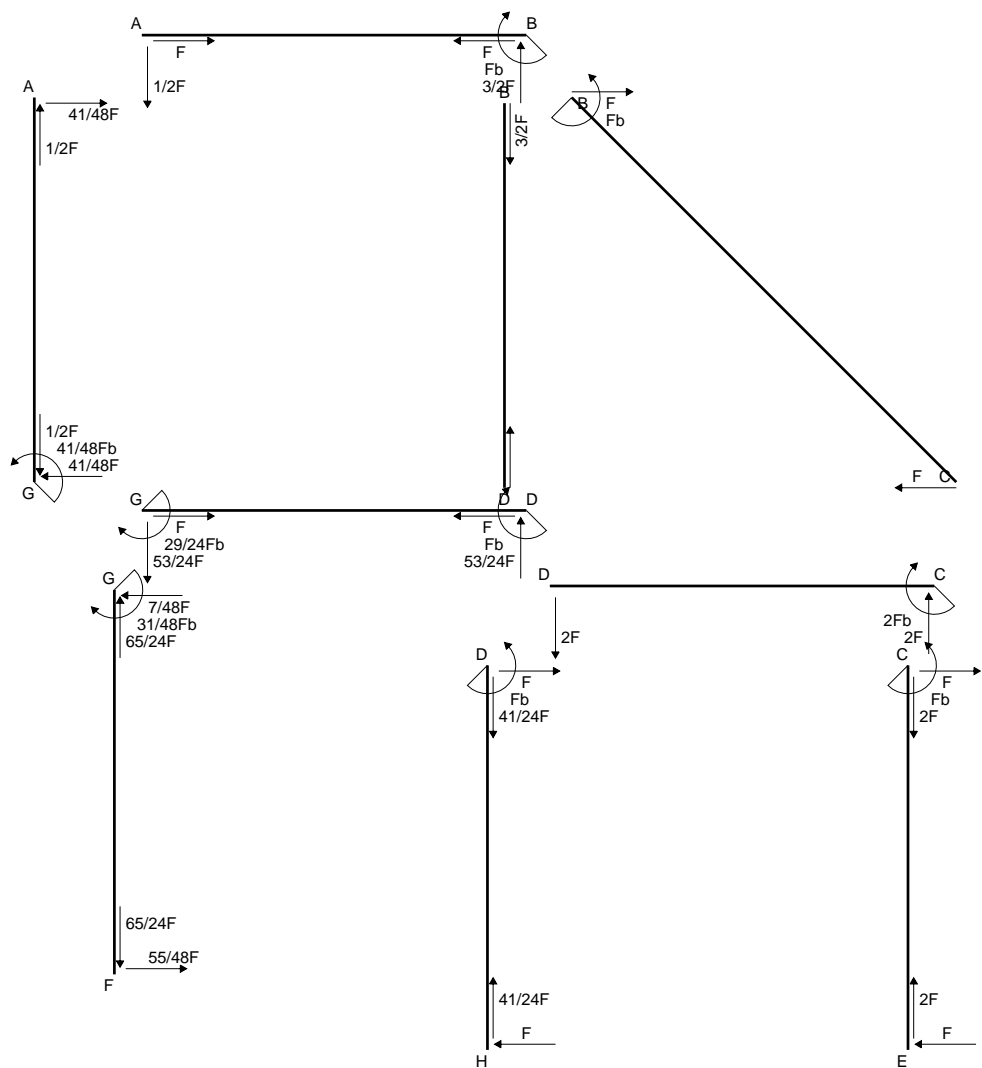

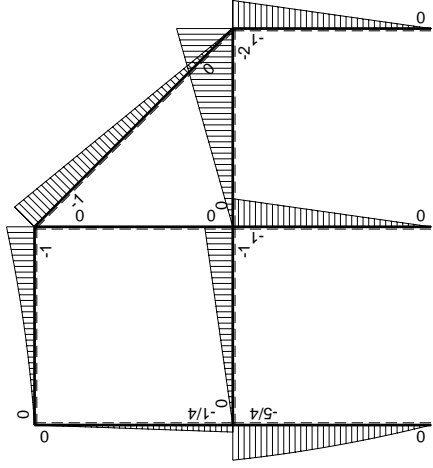
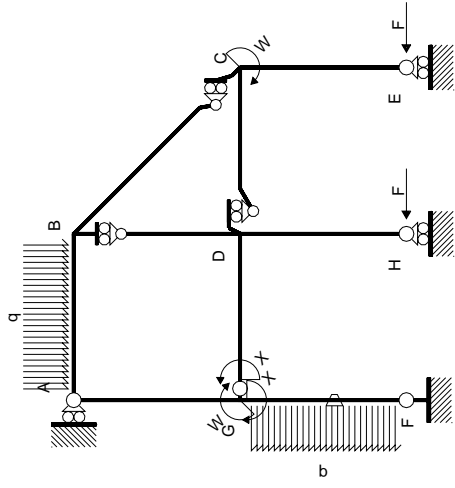

Schema di calcolo iperstatico

M_0 flessione da carichi assegnati

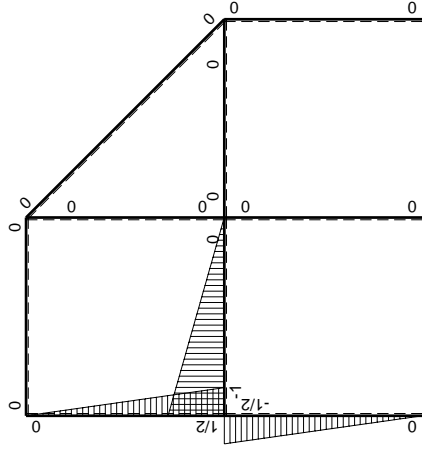

M_x flessione da iperstatica $X=1$

Quadro contributi PLV per iperstatica $X=W_{GD}$

→	$M_x(x)$	$M_o(x)$	θ	$M_x M_o$	$M_x \theta$	$M_x M_x$	$\int M_x(M_o/EJ+\theta)dx$	$\int X M_x M_x/EJdx$
AB b	0	$-1/2Fx-1/2qx^2$	0	0	0	0	0+0	0
BA b	0	$Fb-3/2Fx+1/2qx^2$	0	0	0	0	0	0
BC $\sqrt{2}b$	0	$-Fb+\sqrt{2}/2Fx$	0	0	0	0	0	0
BD b	0	0	0	0	0	0	0+0	0
DB b	0	0	0	0	0	0	0	0
DC b	0	$-2Fx$	0	0	0	0	0+0	0
CD b	0	$2Fb-2Fx$	0	0	0	0	0	0
CE b	0	$-Fb+Fx$	0	0	0	0	0+0	0
EC b	0	Fx	0	0	0	0	0	0
FG b	$-1/2x/b$	$-7/4Fx+1/2qx^2$	$-Fb/EJ$	$7/8Fx^2/b-1/4qx^3/b$	$1/2Fx/EJ$	$1/4x^2/b^2$	$(11/48+1/4)Fb^2/EJ$	$1/12Xb/EJ$
GF b	$1/2-1/2x/b$	$5/4Fb-3/4Fx-1/2qx^2$	Fb/EJ	$5/8Fb-Fx+1/8Fx^2/b+1/4qx^3/b$	$1/2Fb/EJ-1/2Fx/EJ$	$1/4-1/2x/b+1/4x^2/b^2$		
GD b	$-1+x/b$	$-Fx$	0	$Fx-Fx^2/b$	0	$1-2x/b+x^2/b^2$	$(1/6+0)Fb^2/EJ$	$1/3Xb/EJ$
DG b	x/b	$Fb-Fx$	0	$Fx-Fx^2/b$	0	x^2/b^2		
DH b	0	$-Fb+Fx$	0	0	0	0	0+0	0
HD b	0	Fx	0	0	0	0		
GA b	$1/2-1/2x/b$	$-1/4Fb+1/4Fx$	0	$-1/8Fb+1/4Fx-1/8Fx^2/b$	0	$1/4-1/2x/b+1/4x^2/b^2$	$(-1/24+0)Fb^2/EJ$	$1/12Xb/EJ$
AG b	$-1/2x/b$	$1/4Fx$	0	$-1/8Fx^2/b$	0	$1/4x^2/b^2$		
	totali						$29/48Fb^2/EJ$	$1/2Xb/EJ$
	iperstatica $X=W_{GD}$						$-29/24Fb$	

Sviluppi di calcolo iperstatica

$$L_{FG}^{xx} = \int_0^b (1/4 x^2/b^2) 1/EJ dx = [1/12 x^3/b^2]_0^b 1/EJ$$

$$= (1/12 b) 1/EJ = 1/12 b/EJ$$

$$L_{GF}^{xx} = \int_0^b (1/4 - 1/2 x/b + 1/4 x^2/b^2) 1/EJ dx = [1/4 x - 1/4 x^2/b + 1/12 x^3/b^2]_0^b 1/EJ$$

$$= (1/4 b - 1/4 b + 1/12 b) 1/EJ = 1/12 b/EJ$$

$$L_{GD}^{xx} = \int_0^b (1 - 2 x/b + x^2/b^2) 1/EJ dx = [x - x^2/b + 1/3 x^3/b^2]_0^b 1/EJ$$

$$= (b - b + 1/3 b) 1/EJ = 1/3 b/EJ$$

$$L_{DG}^{xx} = \int_0^b (x^2/b^2) 1/EJ dx = [1/3 x^3/b^2]_0^b 1/EJ$$

$$= (1/3 b) 1/EJ = 1/3 b/EJ$$

$$L_{GA}^{xx} = \int_0^b (1/4 - 1/2 x/b + 1/4 x^2/b^2) 1/EJ dx = [1/4 x - 1/4 x^2/b + 1/12 x^3/b^2]_0^b 1/EJ$$

$$= (1/4 b - 1/4 b + 1/12 b) 1/EJ = 1/12 b/EJ$$

$$L_{AG}^{xx} = \int_0^b (1/4 x^2/b^2) 1/EJ dx = [1/12 x^3/b^2]_0^b 1/EJ$$

$$= (1/12 b) 1/EJ = 1/12 b/EJ$$

$$L_{FG}^{xo} = \int_0^b (7/8 x^2/b^2 - 1/4 x^3/b^3) Fb 1/EJ dx + \int_0^b (1/2 x/b) \theta dx$$

$$= [7/24 x^3/b^2 - 1/16 x^4/b^3]_0^b Fb 1/EJ + [1/4 x^2/b]_0^b \theta$$

$$= (7/24 b - 1/16 b) Fb 1/EJ + (1/4 b) \theta = 23/48 Fb^2/EJ$$

$$L_{GF}^{xo} = \int_0^b (5/8 - x/b + 1/8 x^2/b^2 + 1/4 x^3/b^3) Fb 1/EJ dx + \int_0^b (-1/2 + 1/2 x/b) \theta dx$$

$$= [5/8 x - 1/2 x^2/b + 1/24 x^3/b^2 + 1/16 x^4/b^3]_0^b Fb 1/EJ + [-1/2 x + 1/4 x^2/b]_0^b \theta$$

$$= (5/8 b - 1/2 b + 1/24 b + 1/16 b) Fb 1/EJ + (-1/2 b + 1/4 b) \theta = 23/48 Fb^2/EJ$$

$$L_{GD}^{xo} = \int_0^b (x/b - x^2/b^2) Fb 1/EJ dx = [1/2 x^2/b - 1/3 x^3/b^2]_0^b Fb 1/EJ$$

$$= (1/2 b - 1/3 b) Fb 1/EJ = 1/6 Fb^2/EJ$$

$$L_{DG}^{xo} = \int_0^b (x/b - x^2/b^2) Fb 1/EJ dx = [1/2 x^2/b - 1/3 x^3/b^2]_0^b Fb 1/EJ$$

$$= (1/2 b - 1/3 b) Fb 1/EJ = 1/6 Fb^2/EJ$$

$$L_{GA}^{xo} = \int_0^b (-1/8 + 1/4 x/b - 1/8 x^2/b^2) Fb 1/EJ dx = [-1/8 x + 1/8 x^2/b - 1/24 x^3/b^2]_0^b Fb 1/EJ$$

$$= (-1/8 b + 1/8 b - 1/24 b) Fb 1/EJ = -1/24 Fb^2/EJ$$

$$L_{AG}^{xo} = \int_0^b (-1/8 x^2/b^2) Fb 1/EJ dx = [-1/24 x^3/b^2]_0^b Fb 1/EJ$$

$$= (-1/24 b) Fb 1/EJ = -1/24 Fb^2/EJ$$

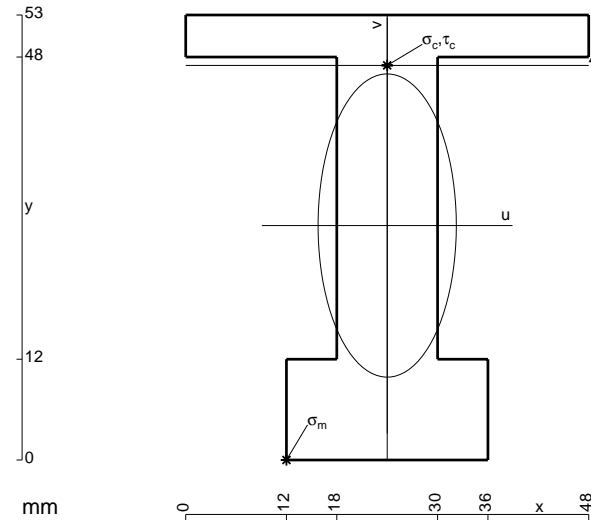

$$A = 960. \text{ mm}^2$$

$$J_u = 313227. \text{ mm}^4$$

$$J_v = 65088. \text{ mm}^4$$

$$y_g = 27.92 \text{ mm}$$

$$T_y = -3960. \text{ N}$$

$$M_x = -2574000. \text{ Nmm}$$

$$x_m = 12. \text{ mm}$$

$$u_m = -12. \text{ mm}$$

$$v_m = -27.92 \text{ mm}$$

$$\sigma_m = -Mv/J_u = -229.5 \text{ N/mm}^2$$

$$x_c = 24. \text{ mm}$$

$$y_c = 47. \text{ mm}$$

$$v_c = 19.08 \text{ mm}$$

$$\sigma_c = -Mv/J_u = 156.8 \text{ N/mm}^2$$

$$\tau_c = 5.956 \text{ N/mm}^2$$

$$\sigma_q = \sqrt{\sigma^2 + 3\tau^2} = 157.1 \text{ N/mm}^2$$

$$S = 5653. \text{ mm}^3$$

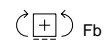
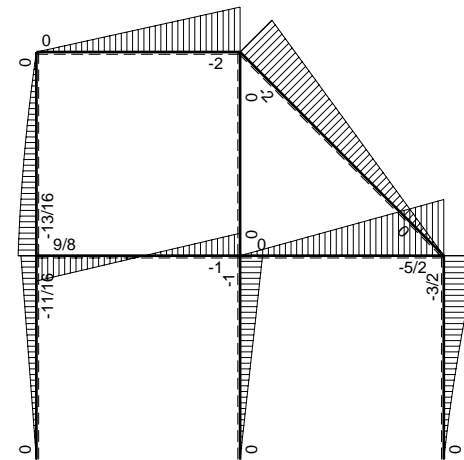
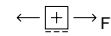
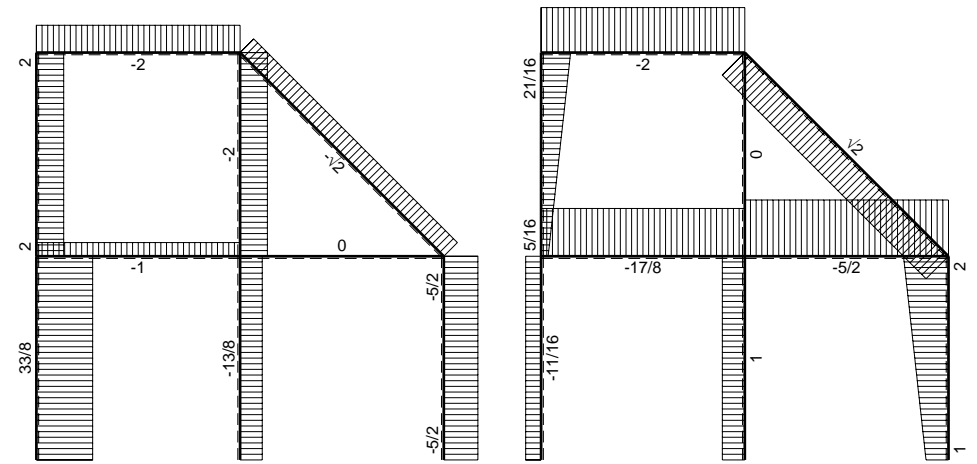
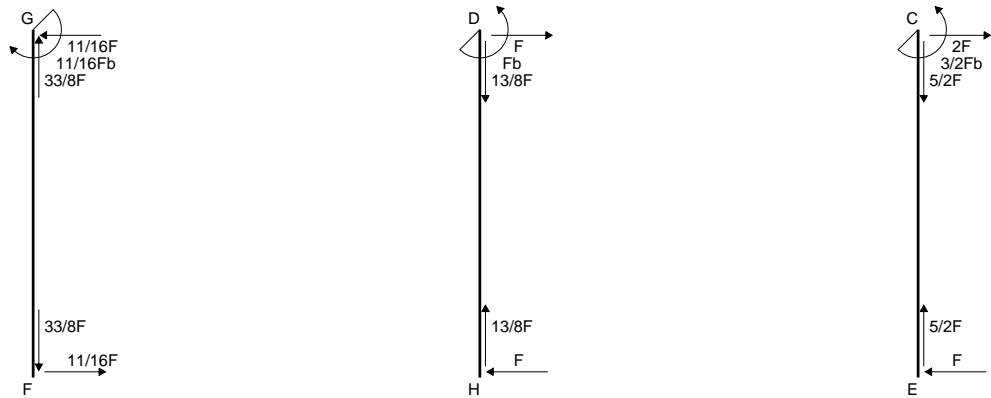
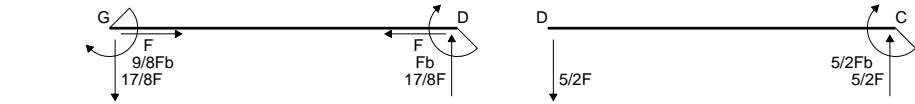
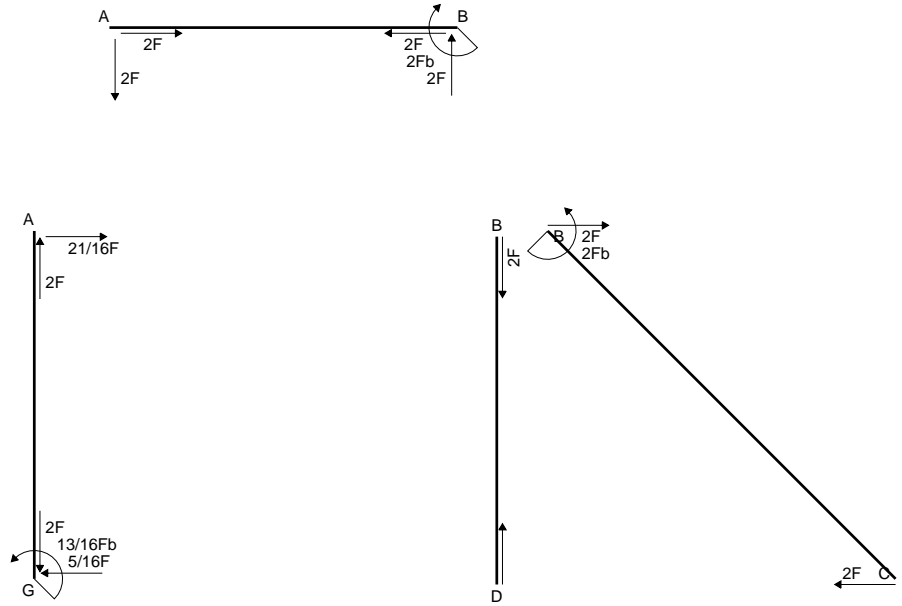

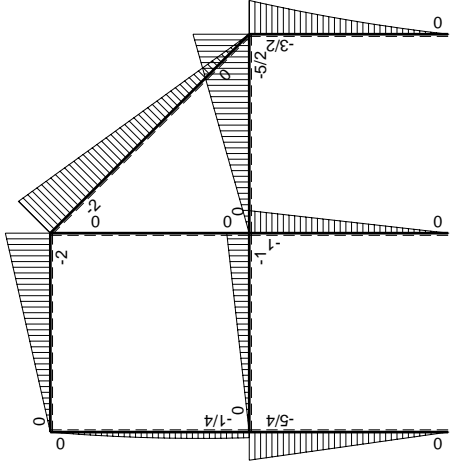
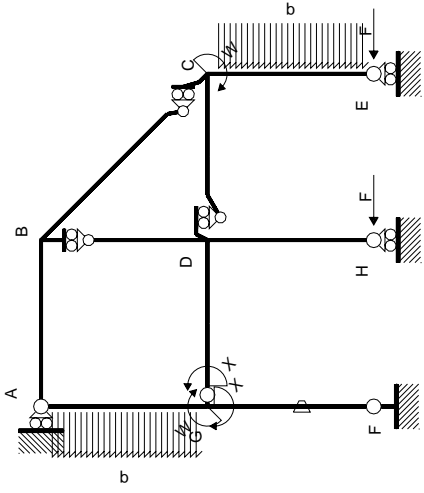

Schema di calcolo iperstatico

M_0 , flessione da carichi assegnati

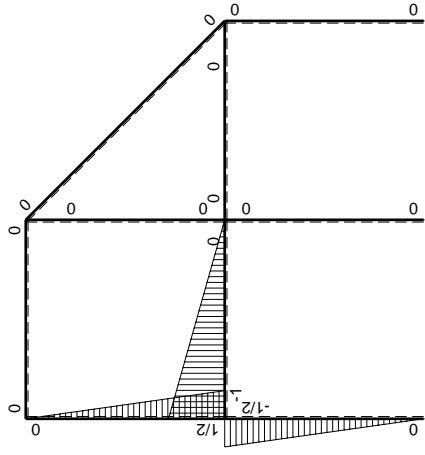

M_x , flessione da iperstatica $X=1$

Quadro contributi PLV per iperstatica $X=W_{GD}$

→	$M_x(x)$	$M_o(x)$	θ	$M_x M_o$	$M_x \theta$	$M_x M_x$	$\int M_x(M_o/EJ+\theta)dx$	$\int X M_x M_x/EJdx$
AB b	0	-2Fx	0	0	0	0	0+0	0
BA b	0	2Fb-2Fx	0	0	0	0	0	0
BC $\sqrt{2}b$	0	-2Fb+ $\sqrt{2}Fx$	0	0	0	0	0	0
BD b	0	0	0	0	0	0	0+0	0
DB b	0	0	0	0	0	0	0	0
DC b	0	-5/2Fx	0	0	0	0	0+0	0
CD b	0	5/2Fb-5/2Fx	0	0	0	0	0	0
CE b	0	-3/2Fb+2Fx-1/2qx ²	0	0	0	0	0+0	0
EC b	0	Fx+1/2qx ²	0	0	0	0	0	0
FG b	-1/2x/b	-5/4Fx	-Fb/EJ	5/8Fx ² /b	1/2Fx/EJ	1/4x ² /b ²	(5/24+1/4)Fb ² /EJ	1/12Xb/EJ
GF b	1/2-1/2x/b	5/4Fb-5/4Fx	Fb/EJ	5/8Fb-5/4Fx+5/8Fx ² /b	1/2Fb/EJ-1/2Fx/EJ	1/4-1/2x/b+1/4x ² /b ²		
GD b	-1+x/b	-Fx	0	Fx-Fx ² /b	0	1-2x/b+x ² /b ²	(1/6+0)Fb ² /EJ	1/3Xb/EJ
DG b	x/b	Fb-Fx	0	Fx-Fx ² /b	0	x ² /b ²		
DH b	0	-Fb+Fx	0	0	0	0	0+0	0
HD b	0	Fx	0	0	0	0	0	0
GA b	1/2-1/2x/b	-1/4Fb-1/4Fx+1/2qx ²	0	-1/8Fb+3/8Fx ² /b-1/4qx ³ /b	0	1/4-1/2x/b+1/4x ² /b ²	(-1/16+0)Fb ² /EJ	1/12Xb/EJ
AG b	-1/2x/b	3/4Fx-1/2qx ²	0	-3/8Fx ² /b+1/4qx ³ /b	0	1/4x ² /b ²		
	totali						9/16Fb ² /EJ	1/2Xb/EJ
	iperstatica $X=W_{GD}$						-9/8Fb	

Sviluppi di calcolo iperstatica

$$L_{FG}^{xx} = \int_0^b (1/4 x^2/b^2) 1/EJ dx = [1/12 x^3/b^2]_0^b 1/EJ$$

$$= (1/12 b) 1/EJ = 1/12 b/EJ$$

$$L_{GF}^{xx} = \int_0^b (1/4 - 1/2 x/b + 1/4 x^2/b^2) 1/EJ dx = [1/4 x - 1/4 x^2/b + 1/12 x^3/b^2]_0^b 1/EJ$$

$$= (1/4 b - 1/4 b + 1/12 b) 1/EJ = 1/12 b/EJ$$

$$L_{GD}^{xx} = \int_0^b (1 - 2 x/b + x^2/b^2) 1/EJ dx = [x - x^2/b + 1/3 x^3/b^2]_0^b 1/EJ$$

$$= (b - b + 1/3 b) 1/EJ = 1/3 b/EJ$$

$$L_{DG}^{xx} = \int_0^b (x^2/b^2) 1/EJ dx = [1/3 x^3/b^2]_0^b 1/EJ$$

$$= (1/3 b) 1/EJ = 1/3 b/EJ$$

$$L_{GA}^{xx} = \int_0^b (1/4 - 1/2 x/b + 1/4 x^2/b^2) 1/EJ dx = [1/4 x - 1/4 x^2/b + 1/12 x^3/b^2]_0^b 1/EJ$$

$$= (1/4 b - 1/4 b + 1/12 b) 1/EJ = 1/12 b/EJ$$

$$L_{AG}^{xx} = \int_0^b (1/4 x^2/b^2) 1/EJ dx = [1/12 x^3/b^2]_0^b 1/EJ$$

$$= (1/12 b) 1/EJ = 1/12 b/EJ$$

$$L_{FG}^{xo} = \int_0^b (5/8 x^2/b^2) Fb 1/EJ dx + \int_0^b (1/2 x/b) \theta dx = [5/24 x^3/b^2]_0^b Fb 1/EJ + [1/4 x^2/b]_0^b \theta$$

$$= (5/24 b) Fb 1/EJ + (1/4 b) \theta = 11/24 Fb^2/EJ$$

$$L_{GF}^{xo} = \int_0^b (5/8 - 5/4 x/b + 5/8 x^2/b^2) Fb 1/EJ dx + \int_0^b (-1/2 + 1/2 x/b) \theta dx$$

$$= [5/8 x - 5/8 x^2/b + 5/24 x^3/b^2]_0^b Fb 1/EJ + [-1/2 x + 1/4 x^2/b]_0^b \theta$$

$$= (5/8 b - 5/8 b + 5/24 b) Fb 1/EJ + (-1/2 b + 1/4 b) \theta = 11/24 Fb^2/EJ$$

$$L_{GD}^{xo} = \int_0^b (x/b - x^2/b^2) Fb 1/EJ dx = [1/2 x^2/b - 1/3 x^3/b^2]_0^b Fb 1/EJ$$

$$= (1/2 b - 1/3 b) Fb 1/EJ = 1/6 Fb^2/EJ$$

$$L_{DG}^{xo} = \int_0^b (x/b - x^2/b^2) Fb 1/EJ dx = [1/2 x^2/b - 1/3 x^3/b^2]_0^b Fb 1/EJ$$

$$= (1/2 b - 1/3 b) Fb 1/EJ = 1/6 Fb^2/EJ$$

$$L_{GA}^{xo} = \int_0^b (-1/8 + 3/8 x^2/b^2 - 1/4 x^3/b^3) Fb 1/EJ dx = [-1/8 x + 1/8 x^3/b^2 - 1/16 x^4/b^3]_0^b Fb 1/EJ$$

$$= (-1/8 b + 1/8 b - 1/16 b) Fb 1/EJ = -1/16 Fb^2/EJ$$

$$L_{AG}^{xo} = \int_0^b (-3/8 x^2/b^2 + 1/4 x^3/b^3) Fb 1/EJ dx = [-1/8 x^3/b^2 + 1/16 x^4/b^3]_0^b Fb 1/EJ$$

$$= (-1/8 b + 1/16 b) Fb 1/EJ = -1/16 Fb^2/EJ$$

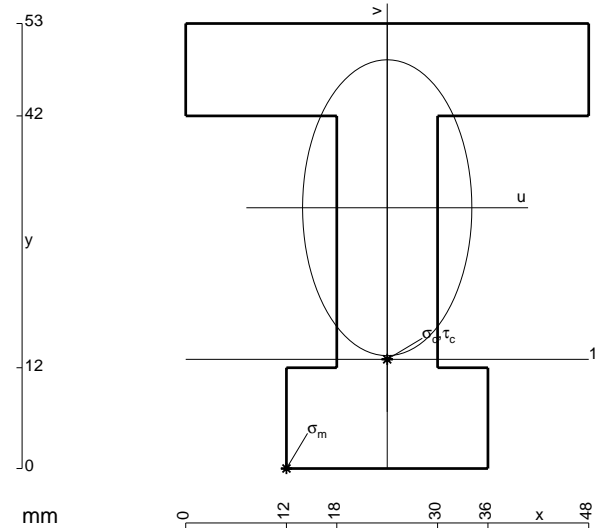

$$A = 1176. \text{ mm}^2$$

$$J_u = 365284. \text{ mm}^4$$

$$J_v = 119520. \text{ mm}^4$$

$$y_g = 31.06 \text{ mm}$$

$$T_y = -4025. \text{ N}$$

$$M_x = -2817500. \text{ Nmm}$$

$$x_m = 12. \text{ mm}$$

$$u_m = -12. \text{ mm}$$

$$v_m = -31.06 \text{ mm}$$

$$\sigma_m = -Mv/J_u = -239.6 \text{ N/mm}^2$$

$$x_c = 24. \text{ mm}$$

$$y_c = 13. \text{ mm}$$

$$v_c = -18.06 \text{ mm}$$

$$\sigma_c = -Mv/J_u = -139.3 \text{ N/mm}^2$$

$$\tau_c = 6.832 \text{ N/mm}^2$$

$$\sigma_\rho = \sqrt{\sigma^2 + 3\tau^2} = 139.8 \text{ N/mm}^2$$

$$S = 7440. \text{ mm}^3$$

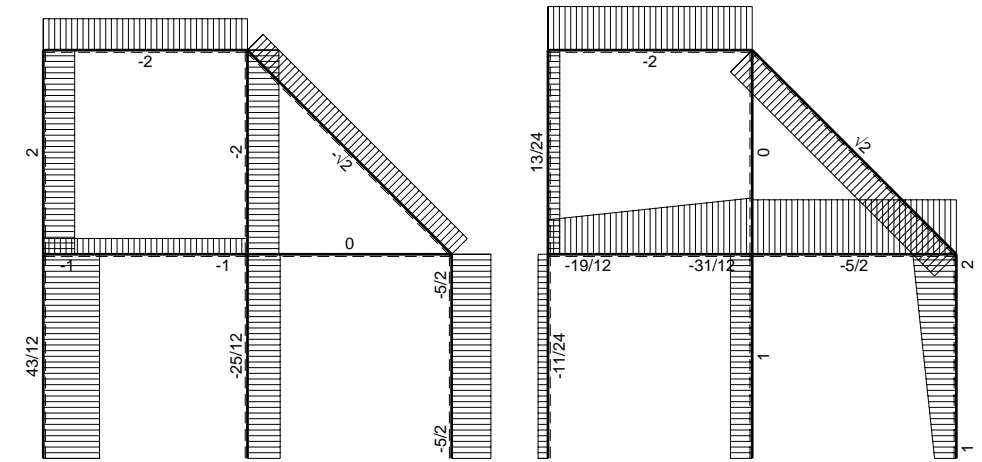
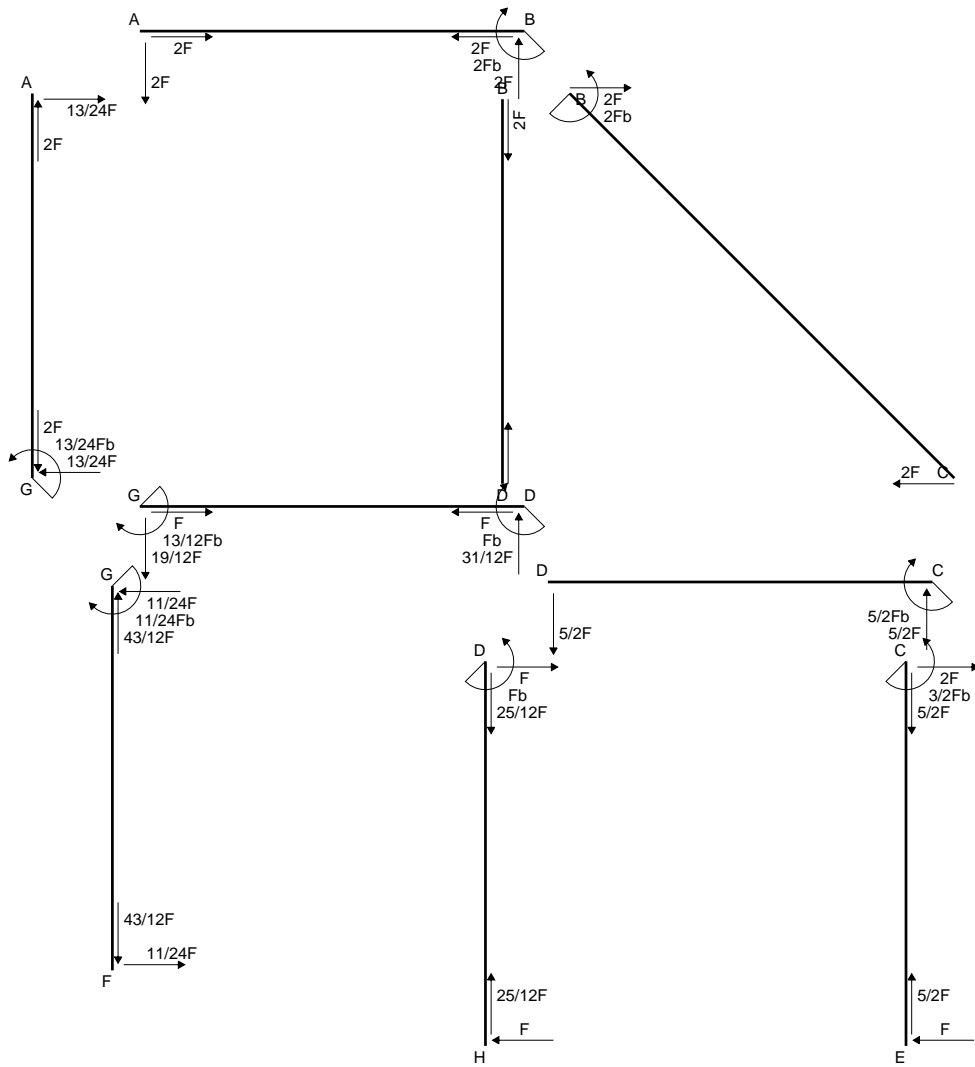

← ⊕ → F

↑ ⊕ ↓ F

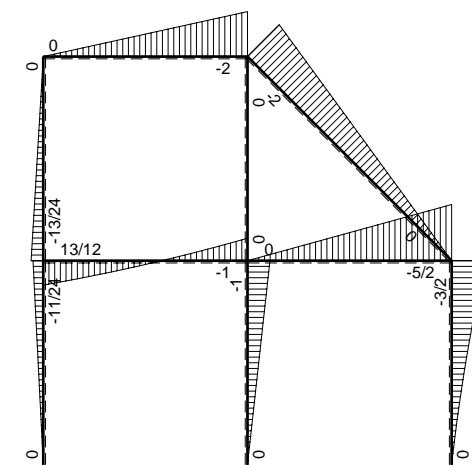

⊕ ⊖ F_b

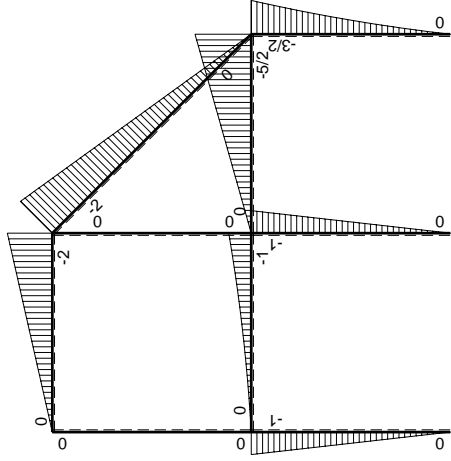
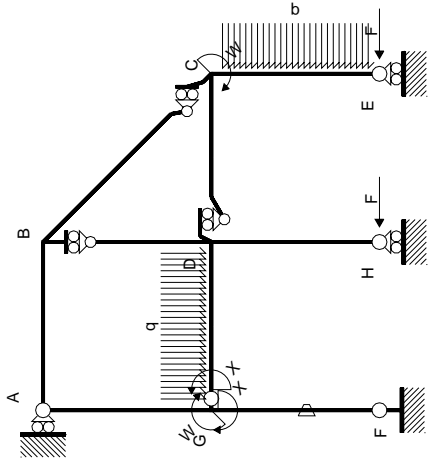

Schema di calcolo iperstatico

M_0 flessione da carichi assegnati

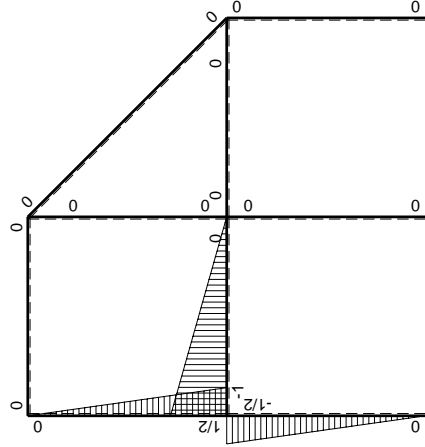

M_x flessione da iperstatica $X=1$

Quadro contributi PLV per iperstatica $X=W_{GD}$

→	$M_x(x)$	$M_o(x)$	θ	$M_x M_o$	$M_x \theta$	$M_x M_x$	$\int M_x(M_o/EJ+\theta)dx$	$\int X M_x M_x/EJ dx$	
AB b	0	-2Fx	0	0	0	0	0+0	0	
BA b	0	2Fb-2Fx	0	0	0	0	0	0	
BC $\sqrt{2}b$	0	-2Fb+ $\sqrt{2}Fx$	0	0	0	0	0	0	
BD b	0	0	0	0	0	0	0+0	0	
DB b	0	0	0	0	0	0	0	0	
DC b	0	-5/2Fx	0	0	0	0	0+0	0	
CD b	0	5/2Fb-5/2Fx	0	0	0	0	0	0	
CE b	0	-3/2Fb+2Fx-1/2qx ²	0	0	0	0	0+0	0	
EC b	0	Fx+1/2qx ²	0	0	0	0	0	0	
FG b	-1/2x/b	-Fx	-Fb/EJ	1/2Fx ² /b	1/2Fx/EJ	1/4x ² /b ²	(1/6+1/4)Fb ² /EJ	1/12Xb/EJ	
GF b	1/2-1/2x/b	Fb-Fx	Fb/EJ	1/2Fb-Fx+1/2Fx ² /b	1/2Fb/EJ-1/2Fx/EJ	1/4-1/2x/b+1/4x ² /b ²			
GD b	-1+x/b	-1/2Fx-1/2qx ²	0	1/2Fx-1/2qx ³ /b	0	1-2x/b+x ² /b ²	(1/8+0)Fb ² /EJ	1/3Xb/EJ	
DG b	x/b	Fb-3/2Fx+1/2qx ²	0	Fx-3/2Fx ² /b+1/2qx ³ /b	0	x ² /b ²			
DH b	0	-Fb+Fx	0	0	0	0	0+0	0	
HD b	0	Fx	0	0	0	0	0	0	
GA b	1/2-1/2x/b	0	0	0	0	1/4-1/2x/b+1/4x ² /b ²	0+0	1/12Xb/EJ	
AG b	-1/2x/b	0	0	0	0	1/4x ² /b ²			
	totali							13/24Fb ² /EJ	1/2Xb/EJ
	iperstatica $X=W_{GD}$							-13/12Fb	

Sviluppi di calcolo iperstatica

$$L_{FG}^{xx} = \int_0^b (1/4 x^2/b^2) 1/EJ dx = [1/12 x^3/b^2]_0^b 1/EJ$$

$$= (1/12 b) 1/EJ = 1/12 b/EJ$$

$$L_{GF}^{xx} = \int_0^b (1/4 - 1/2 x/b + 1/4 x^2/b^2) 1/EJ dx = [1/4 x - 1/4 x^2/b + 1/12 x^3/b^2]_0^b 1/EJ$$

$$= (1/4 b - 1/4 b + 1/12 b) 1/EJ = 1/12 b/EJ$$

$$L_{GD}^{xx} = \int_0^b (1 - 2 x/b + x^2/b^2) 1/EJ dx = [x - x^2/b + 1/3 x^3/b^2]_0^b 1/EJ$$

$$= (b - b + 1/3 b) 1/EJ = 1/3 b/EJ$$

$$L_{DG}^{xx} = \int_0^b (x^2/b^2) 1/EJ dx = [1/3 x^3/b^2]_0^b 1/EJ$$

$$= (1/3 b) 1/EJ = 1/3 b/EJ$$

$$L_{GA}^{xx} = \int_0^b (1/4 - 1/2 x/b + 1/4 x^2/b^2) 1/EJ dx = [1/4 x - 1/4 x^2/b + 1/12 x^3/b^2]_0^b 1/EJ$$

$$= (1/4 b - 1/4 b + 1/12 b) 1/EJ = 1/12 b/EJ$$

$$L_{AG}^{xx} = \int_0^b (1/4 x^2/b^2) 1/EJ dx = [1/12 x^3/b^2]_0^b 1/EJ$$

$$= (1/12 b) 1/EJ = 1/12 b/EJ$$

$$L_{FG}^{xo} = \int_0^b (1/2 x^2/b^2) Fb 1/EJ dx + \int_0^b (1/2 x/b) \theta dx = [1/6 x^3/b^2]_0^b Fb 1/EJ + [1/4 x^2/b]_0^b \theta$$

$$= (1/6 b) Fb 1/EJ + (1/4 b) \theta = 5/12 Fb^2/EJ$$

$$L_{GF}^{xo} = \int_0^b (1/2 - x/b + 1/2 x^2/b^2) Fb 1/EJ dx + \int_0^b (-1/2 + 1/2 x/b) \theta dx$$

$$= [1/2 x - 1/2 x^2/b + 1/6 x^3/b^2]_0^b Fb 1/EJ + [-1/2 x + 1/4 x^2/b]_0^b \theta$$

$$= (1/2 b - 1/2 b + 1/6 b) Fb 1/EJ + (-1/2 b + 1/4 b) \theta = 5/12 Fb^2/EJ$$

$$L_{GD}^{xo} = \int_0^b (1/2 x/b - 1/2 x^3/b^3) Fb 1/EJ dx = [1/4 x^2/b - 1/8 x^4/b^3]_0^b Fb 1/EJ$$

$$= (1/4 b - 1/8 b) Fb 1/EJ = 1/8 Fb^2/EJ$$

$$L_{DG}^{xo} = \int_0^b (x/b - 3/2 x^2/b^2 + 1/2 x^3/b^3) Fb 1/EJ dx = [1/2 x^2/b - 1/2 x^3/b^2 + 1/8 x^4/b^3]_0^b Fb 1/EJ$$

$$= (1/2 b - 1/2 b + 1/8 b) Fb 1/EJ = 1/8 Fb^2/EJ$$

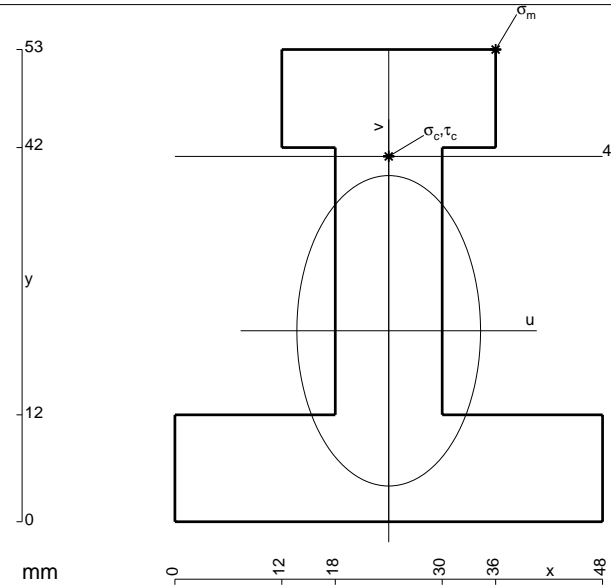

- A = 1200. mm²
- J_u = 364306. mm⁴
- J_v = 127584. mm⁴
- y_g = 21.43 mm
- T_y = -3075. N
- M_x = -2306250. Nmm
- x_m = 36. mm
- y_m = 53. mm
- u_m = 12. mm
- v_m = 31.57 mm
- σ_m = -Mv/J_u = 199.9 N/mm²
- x_c = 24. mm
- y_c = 41. mm
- v_c = 19.57 mm
- σ_c = -Mv/J_u = 123.9 N/mm²
- τ_c = 5.01 N/mm²
- σ_q = √σ²+3τ² = 124.2 N/mm²
- S = 7123. mm³

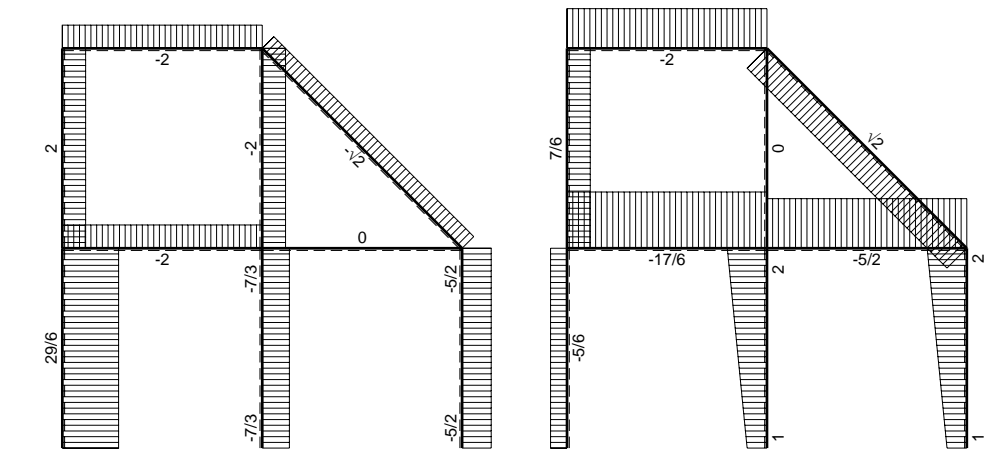
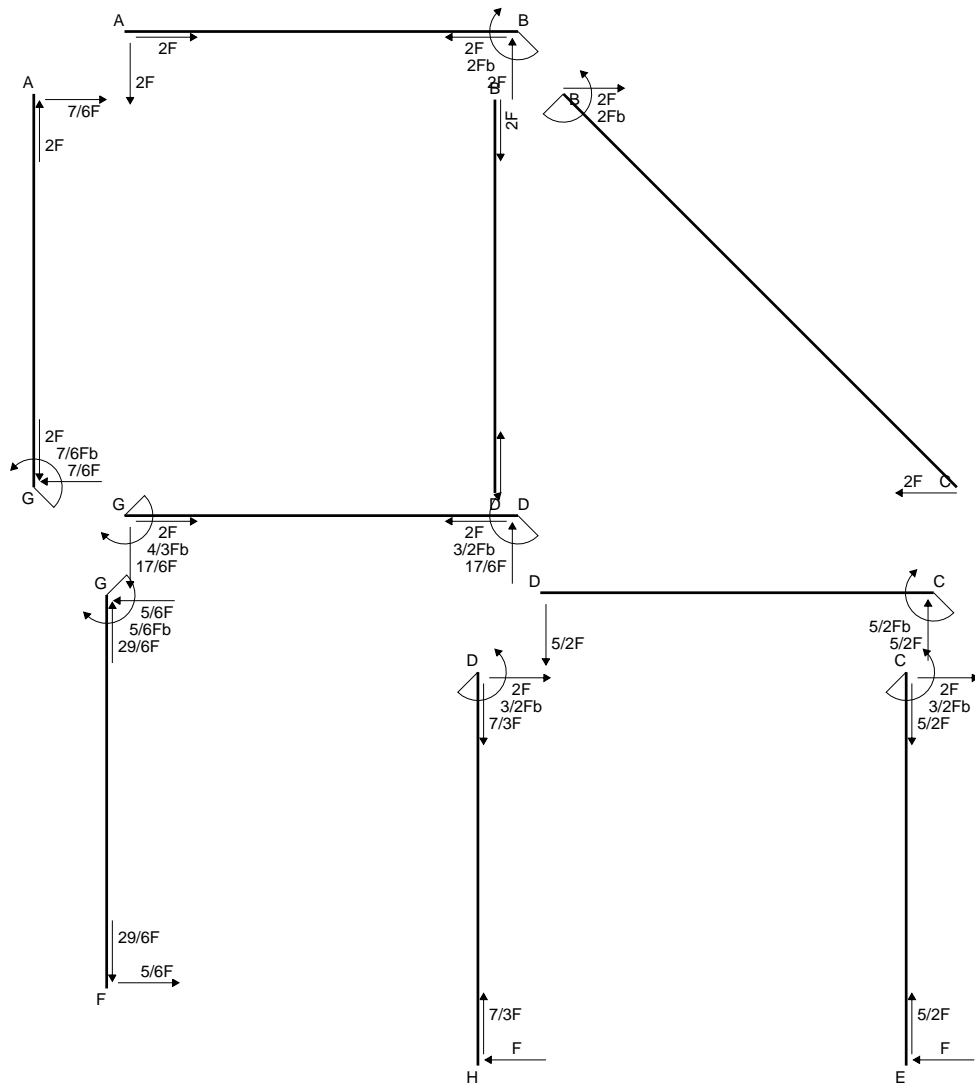

← (+) → F

↑ (+) ↓ F

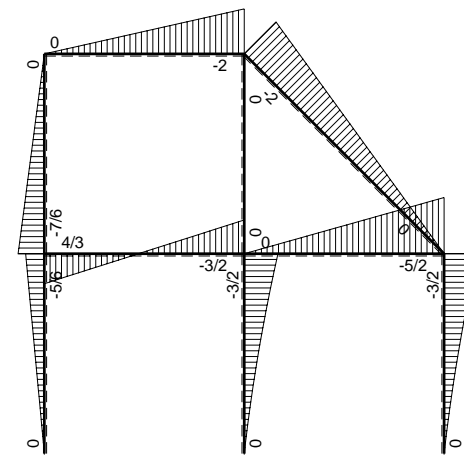

↺ (+) ↻ F_b

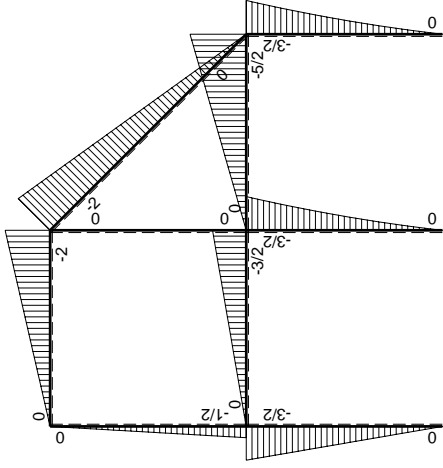
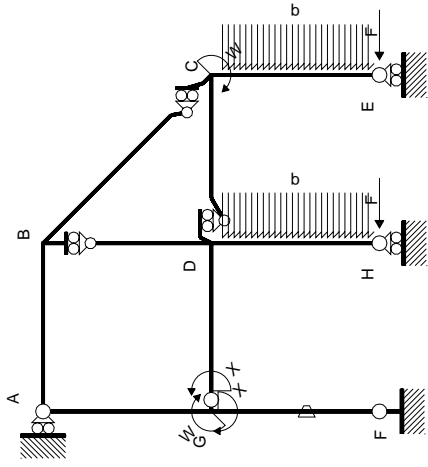

Schema di calcolo iperstatico

M_0 flessione da carichi assegnati

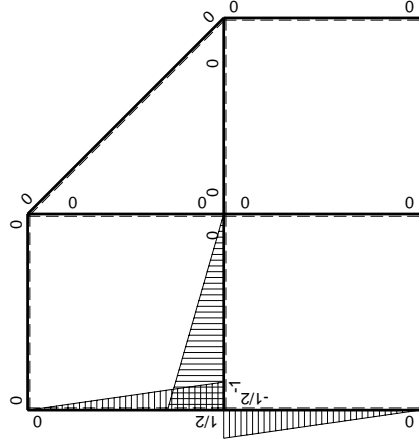

M_1 flessione da iperstatica $X=1$

Quadro contributi PLV per iperstatica $X=W_{GD}$

→	$M_x(x)$	$M_o(x)$	θ	$M_x M_o$	$M_x \theta$	$M_x M_x$	$\int M_x(M_o/EJ+\theta)dx$	$\int X M_x M_x / EJ dx$
AB b	0	-2Fx	0	0	0	0	0+0	0
BA b	0	2Fb-2Fx	0	0	0	0	0	0
BC $\sqrt{2}b$	0	-2Fb+ $\sqrt{2}Fx$	0	0	0	0	0	0
BD b	0	0	0	0	0	0	0+0	0
DB b	0	0	0	0	0	0	0	0
DC b	0	-5/2Fx	0	0	0	0	0+0	0
CD b	0	5/2Fb-5/2Fx	0	0	0	0	0	0
CE b	0	-3/2Fb+2Fx-1/2qx ²	0	0	0	0	0+0	0
EC b	0	Fx+1/2qx ²	0	0	0	0	0	0
FG b	-1/2x/b	-3/2Fx	-Fb/EJ	3/4Fx ² /b	1/2Fx/EJ	1/4x ² /b ²	(1/4+1/4)Fb ² /EJ	1/12Xb/EJ
GF b	1/2-1/2x/b	3/2Fb-3/2Fx	Fb/EJ	3/4Fb-3/2Fx+3/4Fx ² /b	1/2Fb/EJ-1/2Fx/EJ	1/4-1/2x/b+1/4x ² /b ²		
GD b	-1+x/b	-3/2Fx	0	3/2Fx-3/2Fx ² /b	0	1-2x/b+x ² /b ²	(1/4+0)Fb ² /EJ	1/3Xb/EJ
DG b	x/b	3/2Fb-3/2Fx	0	3/2Fx-3/2Fx ² /b	0	x ² /b ²		
DH b	0	-3/2Fb+2Fx-1/2qx ²	0	0	0	0	0+0	0
HD b	0	Fx+1/2qx ²	0	0	0	0	0	0
GA b	1/2-1/2x/b	-1/2Fb+1/2Fx	0	-1/4Fb+1/2Fx-1/4Fx ² /b	0	1/4-1/2x/b+1/4x ² /b ²	(-1/12+0)Fb ² /EJ	1/12Xb/EJ
AG b	-1/2x/b	1/2Fx	0	-1/4Fx ² /b	0	1/4x ² /b ²		
	totali						2/3Fb ² /EJ	1/2Xb/EJ
	iperstatica $X=W_{GD}$						-4/3Fb	

Sviluppi di calcolo iperstatica

$$L_{FG}^{xx} = \int_0^b (1/4 x^2/b^2) 1/EJ dx = [1/12 x^3/b^2]_0^b 1/EJ$$

$$= (1/12 b) 1/EJ = 1/12 b/EJ$$

$$L_{GF}^{xx} = \int_0^b (1/4 - 1/2 x/b + 1/4 x^2/b^2) 1/EJ dx = [1/4 x - 1/4 x^2/b + 1/12 x^3/b^2]_0^b 1/EJ$$

$$= (1/4 b - 1/4 b + 1/12 b) 1/EJ = 1/12 b/EJ$$

$$L_{GD}^{xx} = \int_0^b (1 - 2 x/b + x^2/b^2) 1/EJ dx = [x - x^2/b + 1/3 x^3/b^2]_0^b 1/EJ$$

$$= (b - b + 1/3 b) 1/EJ = 1/3 b/EJ$$

$$L_{DG}^{xx} = \int_0^b (x^2/b^2) 1/EJ dx = [1/3 x^3/b^2]_0^b 1/EJ$$

$$= (1/3 b) 1/EJ = 1/3 b/EJ$$

$$L_{GA}^{xx} = \int_0^b (1/4 - 1/2 x/b + 1/4 x^2/b^2) 1/EJ dx = [1/4 x - 1/4 x^2/b + 1/12 x^3/b^2]_0^b 1/EJ$$

$$= (1/4 b - 1/4 b + 1/12 b) 1/EJ = 1/12 b/EJ$$

$$L_{AG}^{xx} = \int_0^b (1/4 x^2/b^2) 1/EJ dx = [1/12 x^3/b^2]_0^b 1/EJ$$

$$= (1/12 b) 1/EJ = 1/12 b/EJ$$

$$L_{FG}^{xo} = \int_0^b (3/4 x^2/b^2) Fb 1/EJ dx + \int_0^b (1/2 x/b) \theta dx = [1/4 x^3/b^2]_0^b Fb 1/EJ + [1/4 x^2/b]_0^b \theta$$

$$= (1/4 b) Fb 1/EJ + (1/4 b) \theta = 1/2 Fb^2/EJ$$

$$L_{GF}^{xo} = \int_0^b (3/4 - 3/2 x/b + 3/4 x^2/b^2) Fb 1/EJ dx + \int_0^b (-1/2 + 1/2 x/b) \theta dx$$

$$= [3/4 x - 3/4 x^2/b + 1/4 x^3/b^2]_0^b Fb 1/EJ + [-1/2 x + 1/4 x^2/b]_0^b \theta$$

$$= (3/4 b - 3/4 b + 1/4 b) Fb 1/EJ + (-1/2 b + 1/4 b) \theta = 1/2 Fb^2/EJ$$

$$L_{GD}^{xo} = \int_0^b (3/2 x/b - 3/2 x^2/b^2) Fb 1/EJ dx = [3/4 x^2/b - 1/2 x^3/b^2]_0^b Fb 1/EJ$$

$$= (3/4 b - 1/2 b) Fb 1/EJ = 1/4 Fb^2/EJ$$

$$L_{DG}^{xo} = \int_0^b (3/2 x/b - 3/2 x^2/b^2) Fb 1/EJ dx = [3/4 x^2/b - 1/2 x^3/b^2]_0^b Fb 1/EJ$$

$$= (3/4 b - 1/2 b) Fb 1/EJ = 1/4 Fb^2/EJ$$

$$L_{GA}^{xo} = \int_0^b (-1/4 + 1/2 x/b - 1/4 x^2/b^2) Fb 1/EJ dx = [-1/4 x + 1/4 x^2/b - 1/12 x^3/b^2]_0^b Fb 1/EJ$$

$$= (-1/4 b + 1/4 b - 1/12 b) Fb 1/EJ = -1/12 Fb^2/EJ$$

$$L_{AG}^{xo} = \int_0^b (-1/4 x^2/b^2) Fb 1/EJ dx = [-1/12 x^3/b^2]_0^b Fb 1/EJ$$

$$= (-1/12 b) Fb 1/EJ = -1/12 Fb^2/EJ$$

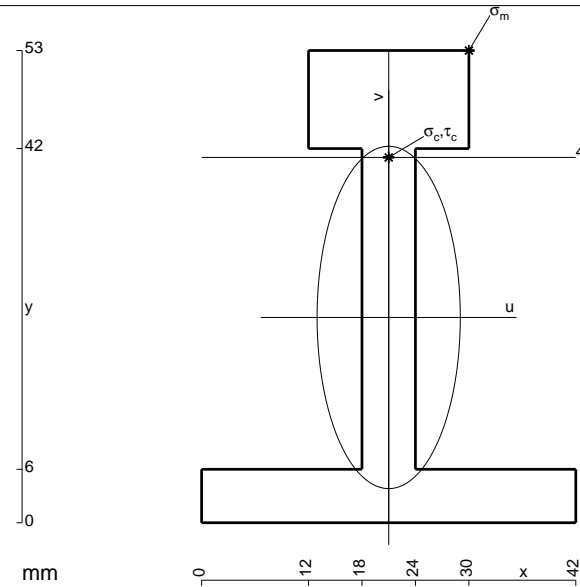

- A = 666. mm²
- J_u = 245945. mm⁴
- J_v = 43038. mm⁴
- y_g = 23.04 mm
- T_y = -2150. N
- M_x = -1720000. Nmm
- x_m = 30. mm
- y_m = 53. mm
- u_m = 9. mm
- v_m = 29.96 mm
- σ_m = -Mv/J_u = 209.5 N/mm²
- x_c = 21. mm
- y_c = 41. mm
- v_c = 17.96 mm
- σ_c = -Mv/J_u = 125.6 N/mm²
- τ_c = 7.217 N/mm²
- σ_q = √σ²+3τ² = 126.2 N/mm²
- S = 4954. mm³

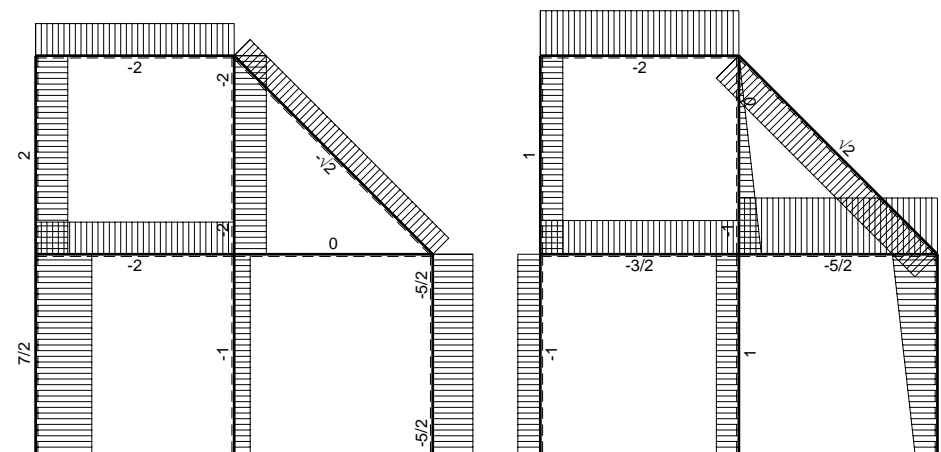
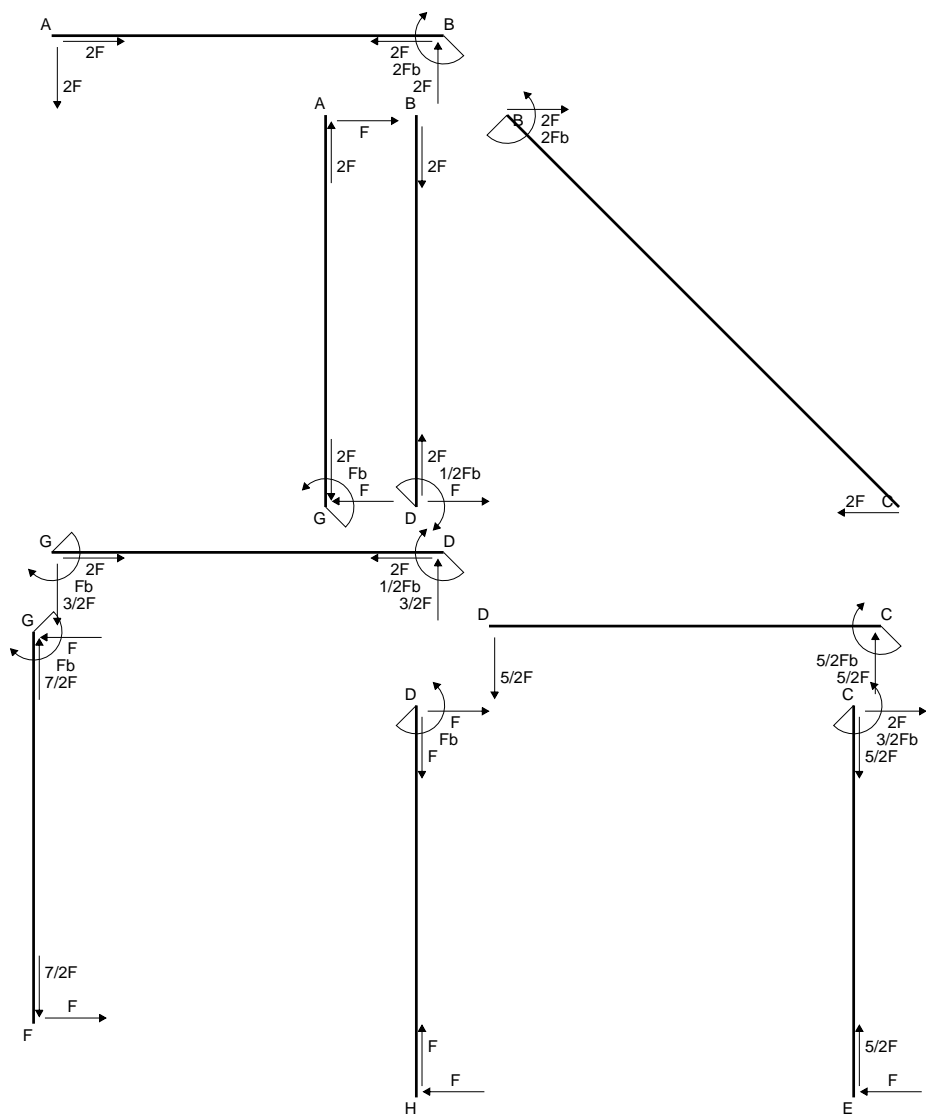

← + → F

↑ + ↓ F

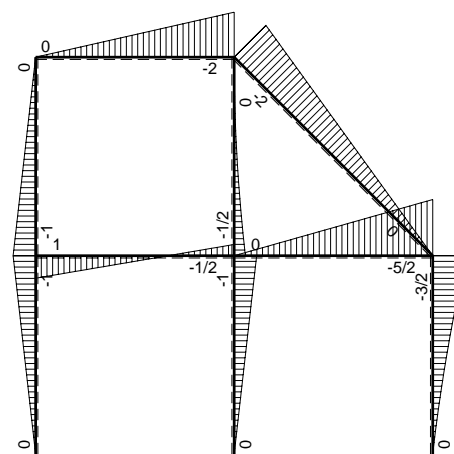

↺ + ↻ Fb

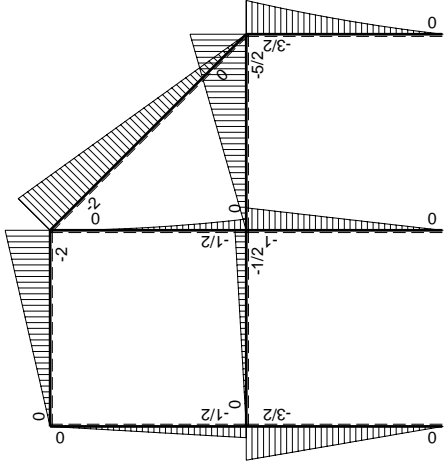
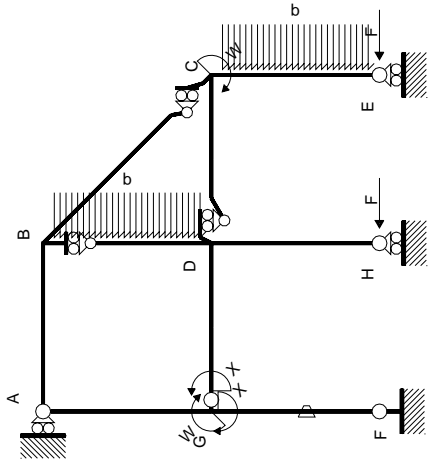

Schema di calcolo iperstatico

M_0 flessione da carichi assegnati

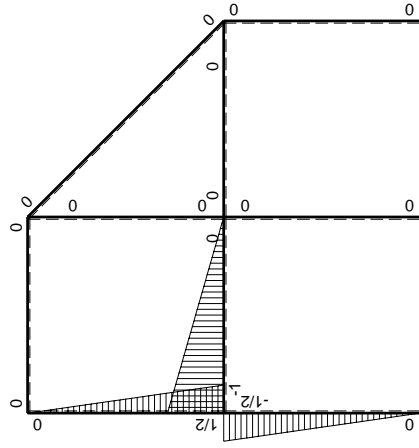

M_x flessione da iperstatica $X=1$

Quadro contributi PLV per iperstatica $X=W_{GD}$

→	$M_x(x)$	$M_o(x)$	θ	$M_x M_o$	$M_x \theta$	$M_x M_x$	$\int M_x(M_o/EJ+\theta)dx$	$\int X M_x M_x / EJ dx$
AB b	0	-2Fx	0	0	0	0	0+0	0
BA b	0	2Fb-2Fx	0	0	0	0	0	0
BC $\sqrt{2}b$	0	-2Fb+ $\sqrt{2}Fx$	0	0	0	0	0	0
BD b	0	-1/2qx ²	0	0	0	0	0+0	0
DB b	0	1/2Fb-Fx+1/2qx ²	0	0	0	0	0	0
DC b	0	-5/2Fx	0	0	0	0	0+0	0
CD b	0	5/2Fb-5/2Fx	0	0	0	0	0	0
CE b	0	-3/2Fb+2Fx-1/2qx ²	0	0	0	0	0+0	0
EC b	0	Fx+1/2qx ²	0	0	0	0	0	0
FG b	-1/2x/b	-3/2Fx	-Fb/EJ	3/4Fx ² /b	1/2Fx/EJ	1/4x ² /b ²	(1/4+1/4)Fb ² /EJ	1/12Xb/EJ
GF b	1/2-1/2x/b	3/2Fb-3/2Fx	Fb/EJ	3/4Fb-3/2Fx+3/4Fx ² /b	1/2Fb/EJ-1/2Fx/EJ	1/4-1/2x/b+1/4x ² /b ²		
GD b	-1+x/b	-1/2Fx	0	1/2Fx-1/2Fx ² /b	0	1-2x/b+x ² /b ²	(1/12+0)Fb ² /EJ	1/3Xb/EJ
DG b	x/b	1/2Fb-1/2Fx	0	1/2Fx-1/2Fx ² /b	0	x ² /b ²		
DH b	0	-Fb+Fx	0	0	0	0	0+0	0
HD b	0	Fx	0	0	0	0	0	0
GA b	1/2-1/2x/b	-1/2Fb+1/2Fx	0	-1/4Fb+1/2Fx-1/4Fx ² /b	0	1/4-1/2x/b+1/4x ² /b ²	(-1/12+0)Fb ² /EJ	1/12Xb/EJ
AG b	-1/2x/b	1/2Fx	0	-1/4Fx ² /b	0	1/4x ² /b ²		
	totali						1/2Fb ² /EJ	1/2Xb/EJ
	iperstatica $X=W_{GD}$						-Fb	

Sviluppi di calcolo iperstatica

$$L_{FG}^{xx} = \int_0^b (1/4 x^2/b^2) 1/EJ dx = [1/12 x^3/b^2]_0^b 1/EJ$$

$$= (1/12 b) 1/EJ = 1/12 b/EJ$$

$$L_{GF}^{xx} = \int_0^b (1/4 - 1/2 x/b + 1/4 x^2/b^2) 1/EJ dx = [1/4 x - 1/4 x^2/b + 1/12 x^3/b^2]_0^b 1/EJ$$

$$= (1/4 b - 1/4 b + 1/12 b) 1/EJ = 1/12 b/EJ$$

$$L_{GD}^{xx} = \int_0^b (1 - 2 x/b + x^2/b^2) 1/EJ dx = [x - x^2/b + 1/3 x^3/b^2]_0^b 1/EJ$$

$$= (b - b + 1/3 b) 1/EJ = 1/3 b/EJ$$

$$L_{DG}^{xx} = \int_0^b (x^2/b^2) 1/EJ dx = [1/3 x^3/b^2]_0^b 1/EJ$$

$$= (1/3 b) 1/EJ = 1/3 b/EJ$$

$$L_{GA}^{xx} = \int_0^b (1/4 - 1/2 x/b + 1/4 x^2/b^2) 1/EJ dx = [1/4 x - 1/4 x^2/b + 1/12 x^3/b^2]_0^b 1/EJ$$

$$= (1/4 b - 1/4 b + 1/12 b) 1/EJ = 1/12 b/EJ$$

$$L_{AG}^{xx} = \int_0^b (1/4 x^2/b^2) 1/EJ dx = [1/12 x^3/b^2]_0^b 1/EJ$$

$$= (1/12 b) 1/EJ = 1/12 b/EJ$$

$$L_{FG}^{xo} = \int_0^b (3/4 x^2/b^2) Fb 1/EJ dx + \int_0^b (1/2 x/b) \theta dx = [1/4 x^3/b^2]_0^b Fb 1/EJ + [1/4 x^2/b]_0^b \theta$$

$$= (1/4 b) Fb 1/EJ + (1/4 b) \theta = 1/2 Fb^2/EJ$$

$$L_{GF}^{xo} = \int_0^b (3/4 - 3/2 x/b + 3/4 x^2/b^2) Fb 1/EJ dx + \int_0^b (-1/2 + 1/2 x/b) \theta dx$$

$$= [3/4 x - 3/4 x^2/b + 1/4 x^3/b^2]_0^b Fb 1/EJ + [-1/2 x + 1/4 x^2/b]_0^b \theta$$

$$= (3/4 b - 3/4 b + 1/4 b) Fb 1/EJ + (-1/2 b + 1/4 b) \theta = 1/2 Fb^2/EJ$$

$$L_{GD}^{xo} = \int_0^b (1/2 x/b - 1/2 x^2/b^2) Fb 1/EJ dx = [1/4 x^2/b - 1/6 x^3/b^2]_0^b Fb 1/EJ$$

$$= (1/4 b - 1/6 b) Fb 1/EJ = 1/12 Fb^2/EJ$$

$$L_{DG}^{xo} = \int_0^b (1/2 x/b - 1/2 x^2/b^2) Fb 1/EJ dx = [1/4 x^2/b - 1/6 x^3/b^2]_0^b Fb 1/EJ$$

$$= (1/4 b - 1/6 b) Fb 1/EJ = 1/12 Fb^2/EJ$$

$$L_{GA}^{xo} = \int_0^b (-1/4 + 1/2 x/b - 1/4 x^2/b^2) Fb 1/EJ dx = [-1/4 x + 1/4 x^2/b - 1/12 x^3/b^2]_0^b Fb 1/EJ$$

$$= (-1/4 b + 1/4 b - 1/12 b) Fb 1/EJ = -1/12 Fb^2/EJ$$

$$L_{AG}^{xo} = \int_0^b (-1/4 x^2/b^2) Fb 1/EJ dx = [-1/12 x^3/b^2]_0^b Fb 1/EJ$$

$$= (-1/12 b) Fb 1/EJ = -1/12 Fb^2/EJ$$

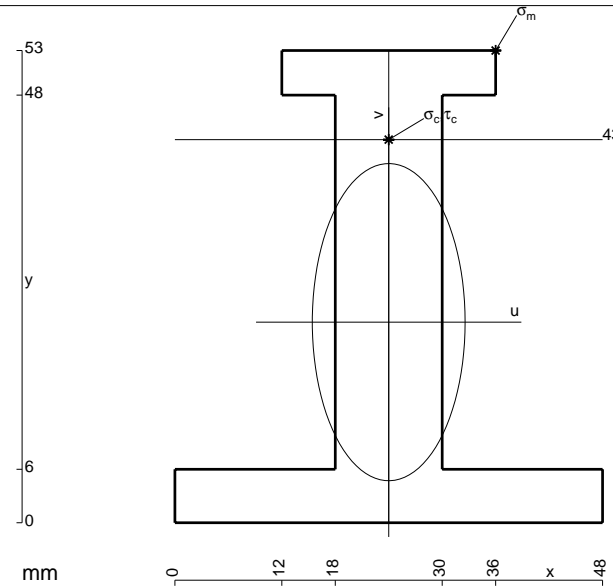

- A = 912. mm²
- J_u = 289000. mm⁴
- J_v = 67104. mm⁴
- y_g = 22.51 mm
- T_y = -2450. N
- M_x = -2082500. Nmm
- x_m = 36. mm
- y_m = 53. mm
- u_m = 12. mm
- v_m = 30.49 mm
- σ_m = -Mv/J_u = 219.7 N/mm²
- x_c = 24. mm
- y_c = 43. mm
- v_c = 20.49 mm
- σ_c = -Mv/J_u = 147.6 N/mm²
- τ_c = 3.347 N/mm²
- σ_q = √σ²+3τ² = 147.7 N/mm²
- S = 4738. mm³

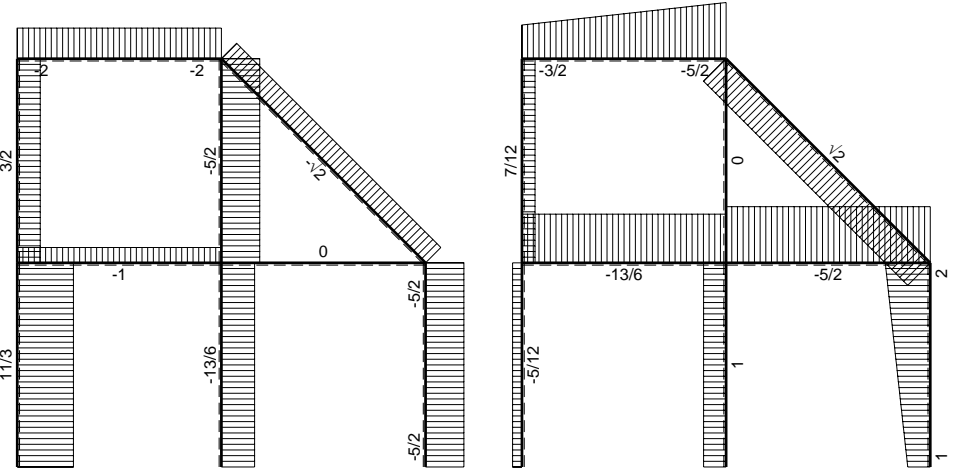
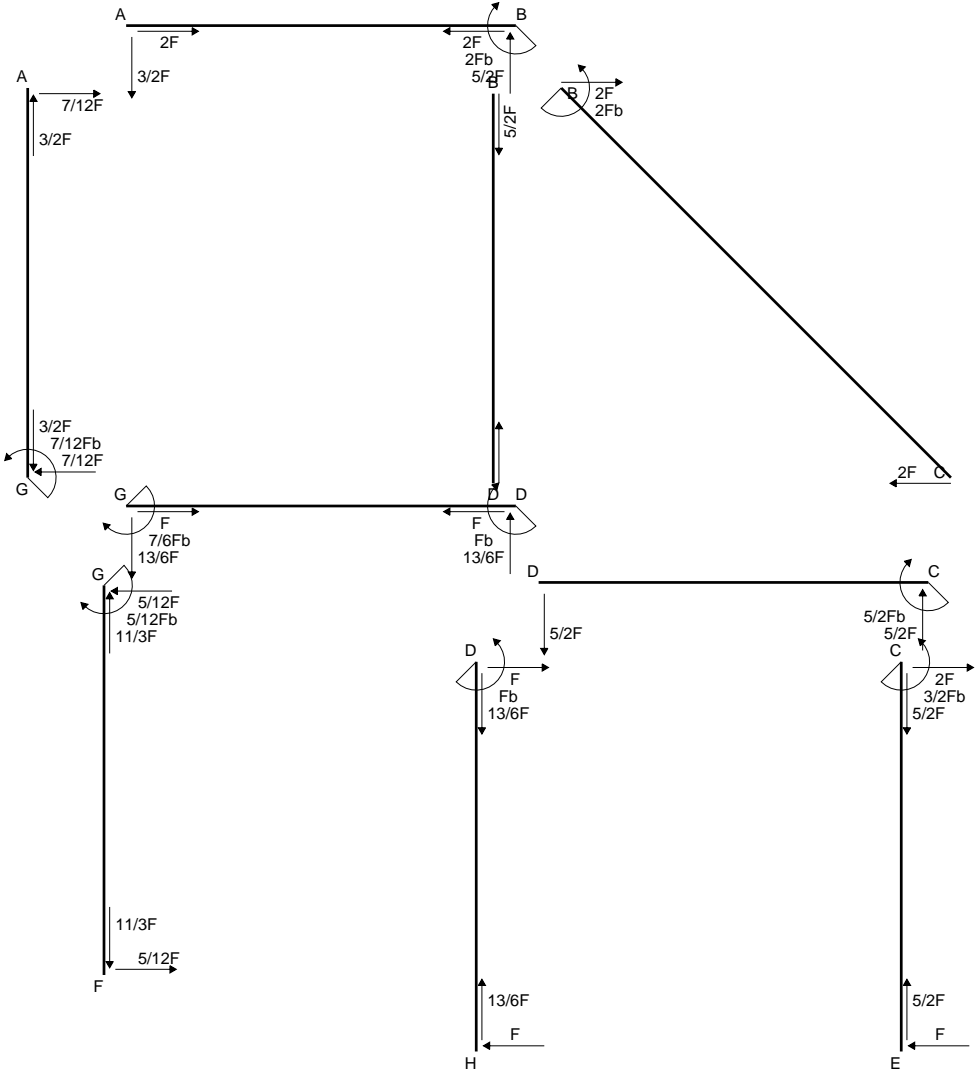

← ⊕ → F

↑ ⊕ ↓ F

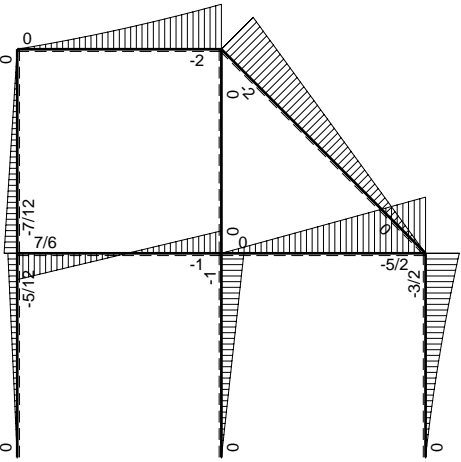

⊕ ⊖ F_b

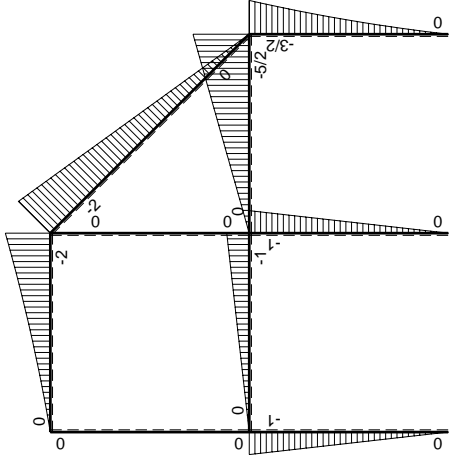
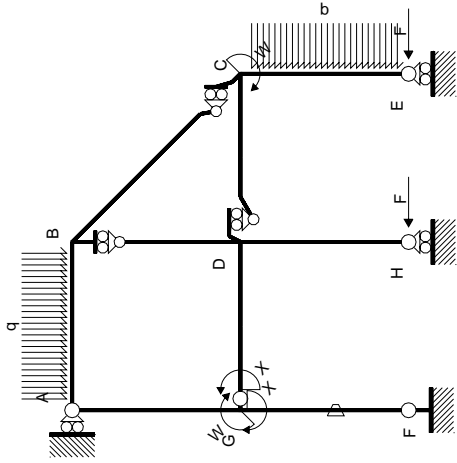

Schema di calcolo iperstatico

M_0 flessione da carichi assegnati

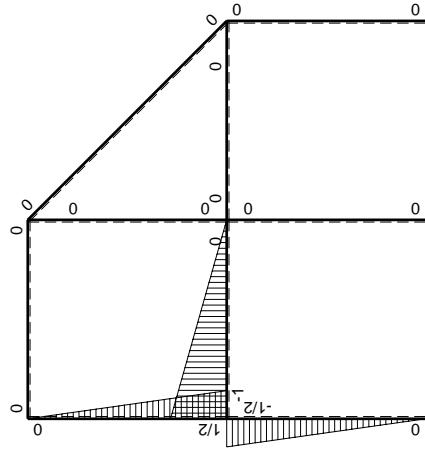

M_x flessione da iperstatica $X=1$

Quadro contributi PLV per iperstatica $X=W_{GD}$

→	$M_x(x)$	$M_o(x)$	θ	$M_x M_o$	$M_x \theta$	$M_x M_x$	$\int M_x(M_o/EJ+\theta)dx$	$\int x M_x M_x/EJ dx$
AB b	0	$-3/2Fx-1/2qx^2$	0	0	0	0	0+0	0
BA b	0	$2Fb-5/2Fx+1/2qx^2$	0	0	0	0	0	0
BC $\sqrt{2}b$	0	$-2Fb+\sqrt{2}Fx$	0	0	0	0	0	0
BD b	0	0	0	0	0	0	0+0	0
DB b	0	0	0	0	0	0	0	0
DC b	0	$-5/2Fx$	0	0	0	0	0+0	0
CD b	0	$5/2Fb-5/2Fx$	0	0	0	0	0	0
CE b	0	$-3/2Fb+2Fx-1/2qx^2$	0	0	0	0	0+0	0
EC b	0	$Fx+1/2qx^2$	0	0	0	0	0	0
FG b	$-1/2x/b$	$-Fx$	$-Fb/EJ$	$1/2Fx^2/b$	$1/2Fx/EJ$	$1/4x^2/b^2$	$(1/6+1/4)Fb^2/EJ$	$1/12Xb/EJ$
GF b	$1/2-1/2x/b$	$Fb-Fx$	Fb/EJ	$1/2Fb-Fx+1/2Fx^2/b$	$1/2Fb/EJ-1/2Fx/EJ$	$1/4-1/2x/b+1/4x^2/b^2$		
GD b	$-1+x/b$	$-Fx$	0	$Fx-Fx^2/b$	0	$1-2x/b+x^2/b^2$	$(1/6+0)Fb^2/EJ$	$1/3Xb/EJ$
DG b	x/b	$Fb-Fx$	0	$Fx-Fx^2/b$	0	x^2/b^2		
DH b	0	$-Fb+Fx$	0	0	0	0	0+0	0
HD b	0	Fx	0	0	0	0	0	0
GA b	$1/2-1/2x/b$	0	0	0	0	$1/4-1/2x/b+1/4x^2/b^2$	0+0	$1/12Xb/EJ$
AG b	$-1/2x/b$	0	0	0	0	$1/4x^2/b^2$		
	totali						$7/12Fb^2/EJ$	$1/2Xb/EJ$
	iperstatica $X=W_{GD}$						$-7/6Fb$	

Sviluppi di calcolo iperstatica

$$L_{FG}^{xx} = \int_0^b (1/4 x^2/b^2) 1/EJ dx = [1/12 x^3/b^2]_0^b 1/EJ$$

$$= (1/12 b) 1/EJ = 1/12 b/EJ$$

$$L_{GF}^{xx} = \int_0^b (1/4 - 1/2 x/b + 1/4 x^2/b^2) 1/EJ dx = [1/4 x - 1/4 x^2/b + 1/12 x^3/b^2]_0^b 1/EJ$$

$$= (1/4 b - 1/4 b + 1/12 b) 1/EJ = 1/12 b/EJ$$

$$L_{GD}^{xx} = \int_0^b (1 - 2 x/b + x^2/b^2) 1/EJ dx = [x - x^2/b + 1/3 x^3/b^2]_0^b 1/EJ$$

$$= (b - b + 1/3 b) 1/EJ = 1/3 b/EJ$$

$$L_{DG}^{xx} = \int_0^b (x^2/b^2) 1/EJ dx = [1/3 x^3/b^2]_0^b 1/EJ$$

$$= (1/3 b) 1/EJ = 1/3 b/EJ$$

$$L_{GA}^{xx} = \int_0^b (1/4 - 1/2 x/b + 1/4 x^2/b^2) 1/EJ dx = [1/4 x - 1/4 x^2/b + 1/12 x^3/b^2]_0^b 1/EJ$$

$$= (1/4 b - 1/4 b + 1/12 b) 1/EJ = 1/12 b/EJ$$

$$L_{AG}^{xx} = \int_0^b (1/4 x^2/b^2) 1/EJ dx = [1/12 x^3/b^2]_0^b 1/EJ$$

$$= (1/12 b) 1/EJ = 1/12 b/EJ$$

$$L_{FG}^{xo} = \int_0^b (1/2 x^2/b^2) Fb 1/EJ dx + \int_0^b (1/2 x/b) \theta dx = [1/6 x^3/b^2]_0^b Fb 1/EJ + [1/4 x^2/b]_0^b \theta$$

$$= (1/6 b) Fb 1/EJ + (1/4 b) \theta = 5/12 Fb^2/EJ$$

$$L_{GF}^{xo} = \int_0^b (1/2 - x/b + 1/2 x^2/b^2) Fb 1/EJ dx + \int_0^b (-1/2 + 1/2 x/b) \theta dx$$

$$= [1/2 x - 1/2 x^2/b + 1/6 x^3/b^2]_0^b Fb 1/EJ + [-1/2 x + 1/4 x^2/b]_0^b \theta$$

$$= (1/2 b - 1/2 b + 1/6 b) Fb 1/EJ + (-1/2 b + 1/4 b) \theta = 5/12 Fb^2/EJ$$

$$L_{GD}^{xo} = \int_0^b (x/b - x^2/b^2) Fb 1/EJ dx = [1/2 x^2/b - 1/3 x^3/b^2]_0^b Fb 1/EJ$$

$$= (1/2 b - 1/3 b) Fb 1/EJ = 1/6 Fb^2/EJ$$

$$L_{DG}^{xo} = \int_0^b (x/b - x^2/b^2) Fb 1/EJ dx = [1/2 x^2/b - 1/3 x^3/b^2]_0^b Fb 1/EJ$$

$$= (1/2 b - 1/3 b) Fb 1/EJ = 1/6 Fb^2/EJ$$

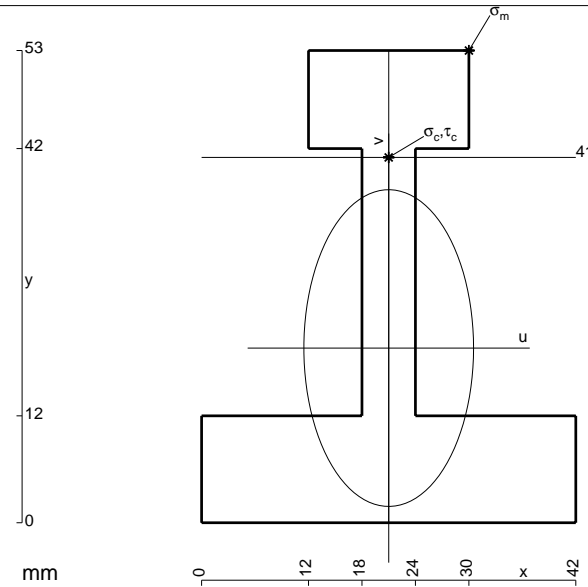

$$A = 882. \text{ mm}^2$$

$$J_u = 278746. \text{ mm}^4$$

$$J_v = 79974. \text{ mm}^4$$

$$y_g = 19.6 \text{ mm}$$

$$T_y = -2125. \text{ N}$$

$$M_x = -1912500. \text{ Nmm}$$

$$x_m = 30. \text{ mm}$$

$$y_m = 53. \text{ mm}$$

$$u_m = 9. \text{ mm}$$

$$v_m = 33.4 \text{ mm}$$

$$\sigma_m = -Mv/J_u = 229.1 \text{ N/mm}^2$$

$$x_c = 21. \text{ mm}$$

$$y_c = 41. \text{ mm}$$

$$v_c = 21.4 \text{ mm}$$

$$\sigma_c = -Mv/J_u = 146.8 \text{ N/mm}^2$$

$$\tau_c = 7.185 \text{ N/mm}^2$$

$$\sigma_\varphi = \sqrt{\sigma^2 + 3\tau^2} = 147.3 \text{ N/mm}^2$$

$$S = 5655. \text{ mm}^3$$

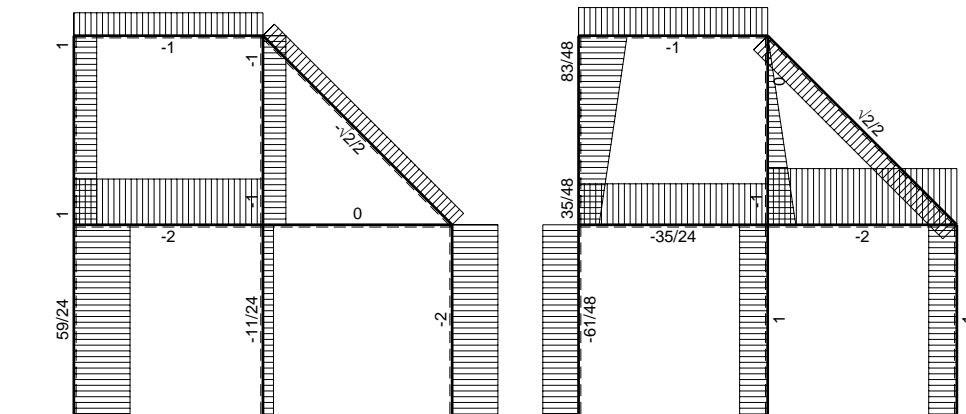
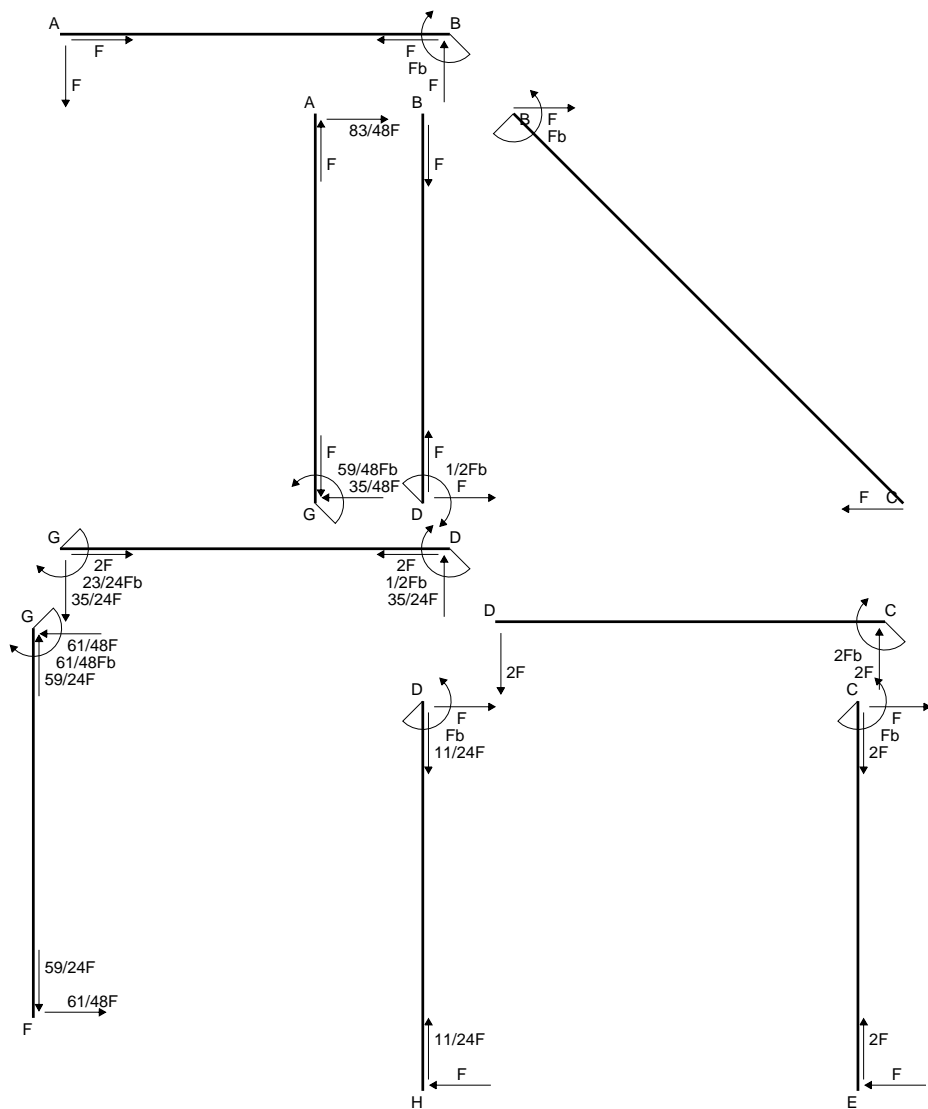

← ⊕ → F

↑ ⊕ ↓ F

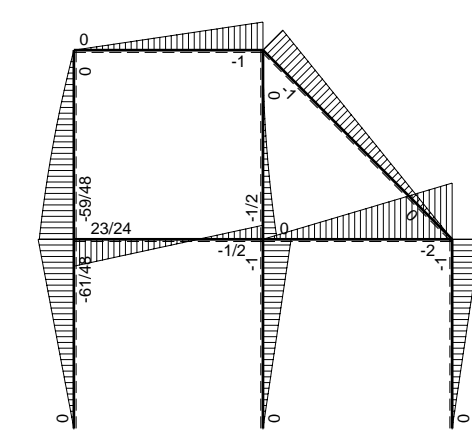

⊕ ⊖ F_b

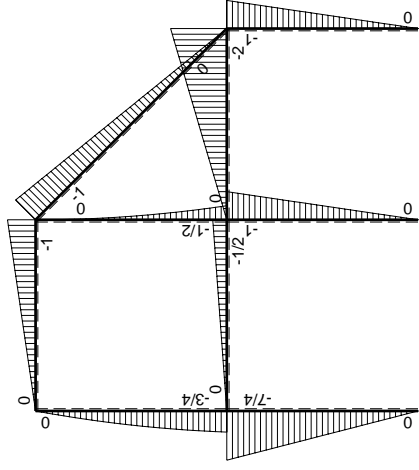
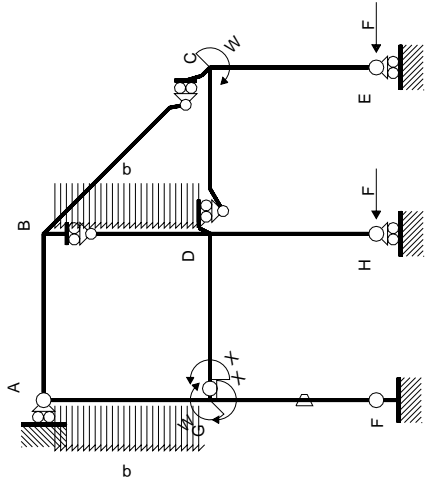

Schema di calcolo iperstatico

M_0 flessione da carichi assegnati

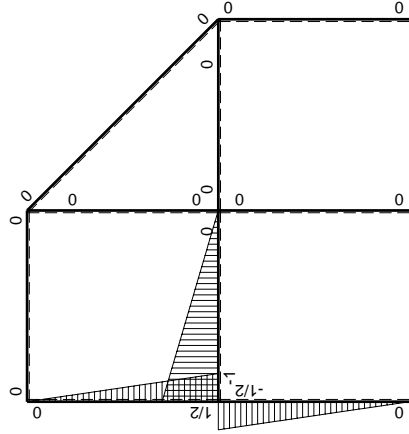

M_x flessione da iperstatica $X=1$

Quadro contributi PLV per iperstatica $X=W_{GD}$

→	$M_x(x)$	$M_o(x)$	θ	$M_x M_o$	$M_x \theta$	$M_x M_x$	$\int M_x(M_o/EJ+\theta)dx$	$\int X M_x M_x/EJdx$
AB b	0	-Fx	0	0	0	0	0+0	0
BA b	0	Fb-Fx	0	0	0	0	0	0
BC $\sqrt{2}b$	0	-Fb+ $\sqrt{2}/2Fx$	0	0	0	0	0	0
BD b	0	-1/2qx ²	0	0	0	0	0+0	0
DB b	0	1/2Fb-Fx+1/2qx ²	0	0	0	0	0	0
DC b	0	-2Fx	0	0	0	0	0+0	0
CD b	0	2Fb-2Fx	0	0	0	0	0	0
CE b	0	-Fb+Fx	0	0	0	0	0+0	0
EC b	0	Fx	0	0	0	0	0	0
FG b	-1/2x/b	-7/4Fx	-Fb/EJ	7/8Fx ² /b	1/2Fx/EJ	1/4x ² /b ²	(7/24+1/4)Fb ² /EJ	1/12Xb/EJ
GF b	1/2-1/2x/b	7/4Fb-7/4Fx	Fb/EJ	7/8Fb-7/4Fx+7/8Fx ² /b	1/2Fb/EJ-1/2Fx/EJ	1/4-1/2x/b+1/4x ² /b ²		
GD b	-1+x/b	-1/2Fx	0	1/2Fx-1/2Fx ² /b	0	1-2x/b+x ² /b ²	(1/12+0)Fb ² /EJ	1/3Xb/EJ
DG b	x/b	1/2Fb-1/2Fx	0	1/2Fx-1/2Fx ² /b	0	x ² /b ²		
DH b	0	-Fb+Fx	0	0	0	0	0+0	0
HD b	0	Fx	0	0	0	0	0	0
GA b	1/2-1/2x/b	-3/4Fb+1/4Fx+1/2qx ²	0	-3/8Fb+1/2Fx+1/8Fx ² /b-1/4qx ³ /b	0	1/4-1/2x/b+1/4x ² /b ²	(-7/48+0)Fb ² /EJ	1/12Xb/EJ
AG b	-1/2x/b	5/4Fx-1/2qx ²	0	-5/8Fx ² /b+1/4qx ³ /b	0	1/4x ² /b ²		
	totali						23/48Fb ² /EJ	1/2Xb/EJ
	iperstatica $X=W_{GD}$						-23/24Fb	

Sviluppi di calcolo iperstatica

$$L_{FG}^{xx} = \int_0^b (1/4 x^2/b^2) 1/EJ dx = [1/12 x^3/b^2]_0^b 1/EJ$$

$$= (1/12 b) 1/EJ = 1/12 b/EJ$$

$$L_{GF}^{xx} = \int_0^b (1/4 - 1/2 x/b + 1/4 x^2/b^2) 1/EJ dx = [1/4 x - 1/4 x^2/b + 1/12 x^3/b^2]_0^b 1/EJ$$

$$= (1/4 b - 1/4 b + 1/12 b) 1/EJ = 1/12 b/EJ$$

$$L_{GD}^{xx} = \int_0^b (1 - 2 x/b + x^2/b^2) 1/EJ dx = [x - x^2/b + 1/3 x^3/b^2]_0^b 1/EJ$$

$$= (b - b + 1/3 b) 1/EJ = 1/3 b/EJ$$

$$L_{DG}^{xx} = \int_0^b (x^2/b^2) 1/EJ dx = [1/3 x^3/b^2]_0^b 1/EJ$$

$$= (1/3 b) 1/EJ = 1/3 b/EJ$$

$$L_{GA}^{xx} = \int_0^b (1/4 - 1/2 x/b + 1/4 x^2/b^2) 1/EJ dx = [1/4 x - 1/4 x^2/b + 1/12 x^3/b^2]_0^b 1/EJ$$

$$= (1/4 b - 1/4 b + 1/12 b) 1/EJ = 1/12 b/EJ$$

$$L_{AG}^{xx} = \int_0^b (1/4 x^2/b^2) 1/EJ dx = [1/12 x^3/b^2]_0^b 1/EJ$$

$$= (1/12 b) 1/EJ = 1/12 b/EJ$$

$$L_{FG}^{xo} = \int_0^b (7/8 x^2/b^2) Fb 1/EJ dx + \int_0^b (1/2 x/b) \theta dx = [7/24 x^3/b^2]_0^b Fb 1/EJ + [1/4 x^2/b]_0^b \theta$$

$$= (7/24 b) Fb 1/EJ + (1/4 b) \theta = 13/24 Fb^2/EJ$$

$$L_{GF}^{xo} = \int_0^b (7/8 - 7/4 x/b + 7/8 x^2/b^2) Fb 1/EJ dx + \int_0^b (-1/2 + 1/2 x/b) \theta dx$$

$$= [7/8 x - 7/8 x^2/b + 7/24 x^3/b^2]_0^b Fb 1/EJ + [-1/2 x + 1/4 x^2/b]_0^b \theta$$

$$= (7/8 b - 7/8 b + 7/24 b) Fb 1/EJ + (-1/2 b + 1/4 b) \theta = 13/24 Fb^2/EJ$$

$$L_{GD}^{xo} = \int_0^b (1/2 x/b - 1/2 x^2/b^2) Fb 1/EJ dx = [1/4 x^2/b - 1/6 x^3/b^2]_0^b Fb 1/EJ$$

$$= (1/4 b - 1/6 b) Fb 1/EJ = 1/12 Fb^2/EJ$$

$$L_{DG}^{xo} = \int_0^b (1/2 x/b - 1/2 x^2/b^2) Fb 1/EJ dx = [1/4 x^2/b - 1/6 x^3/b^2]_0^b Fb 1/EJ$$

$$= (1/4 b - 1/6 b) Fb 1/EJ = 1/12 Fb^2/EJ$$

$$L_{GA}^{xo} = \int_0^b (-3/8 + 1/2 x/b + 1/8 x^2/b^2 - 1/4 x^3/b^3) Fb 1/EJ dx$$

$$= [-3/8 x + 1/4 x^2/b + 1/24 x^3/b^2 - 1/16 x^4/b^3]_0^b Fb 1/EJ$$

$$= (-3/8 b + 1/4 b + 1/24 b - 1/16 b) Fb 1/EJ = -7/48 Fb^2/EJ$$

$$L_{AG}^{xo} = \int_0^b (-5/8 x^2/b^2 + 1/4 x^3/b^3) Fb 1/EJ dx = [-5/24 x^3/b^2 + 1/16 x^4/b^3]_0^b Fb 1/EJ$$

$$= (-5/24 b + 1/16 b) Fb 1/EJ = -7/48 Fb^2/EJ$$

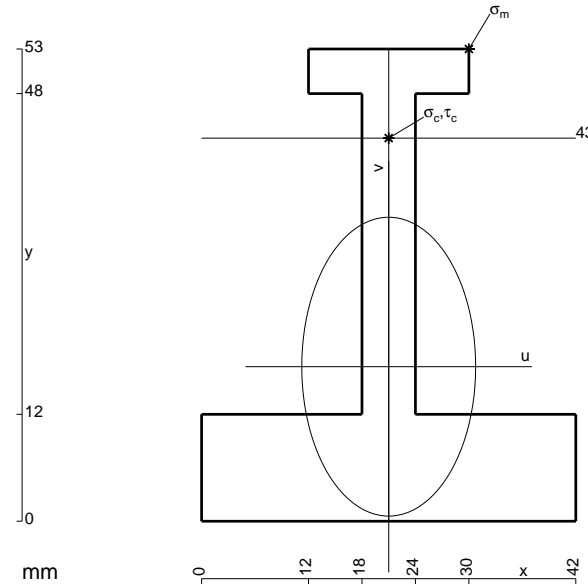

$$A = 810. \text{ mm}^2$$

$$J_u = 227958. \text{ mm}^4$$

$$J_v = 77166. \text{ mm}^4$$

$$y_g = 17.34 \text{ mm}$$

$$T_y = -1600. \text{ N}$$

$$M_x = -1520000. \text{ Nmm}$$

$$x_m = 30. \text{ mm}$$

$$y_m = 53. \text{ mm}$$

$$u_m = 9. \text{ mm}$$

$$v_m = 35.66 \text{ mm}$$

$$\sigma_m = -Mv/J_u = 237.7 \text{ N/mm}^2$$

$$x_c = 21. \text{ mm}$$

$$y_c = 43. \text{ mm}$$

$$v_c = 25.66 \text{ mm}$$

$$\sigma_c = -Mv/J_u = 171.1 \text{ N/mm}^2$$

$$\tau_c = 4.479 \text{ N/mm}^2$$

$$\sigma_t = \sqrt{\sigma_c^2 + 3\tau_c^2} = 171.2 \text{ N/mm}^2$$

$$S = 3829. \text{ mm}^3$$

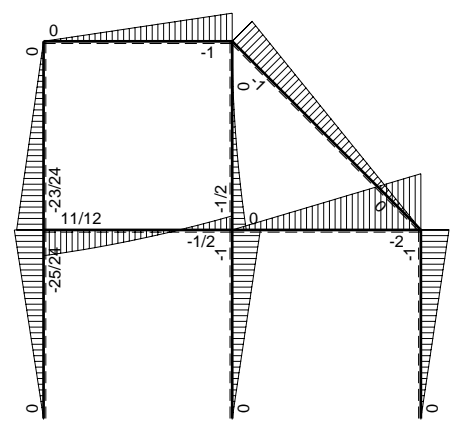
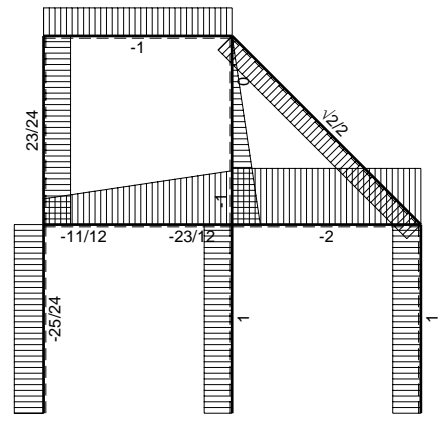
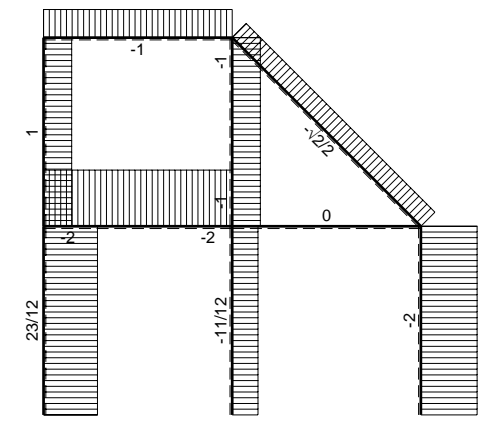
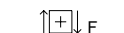
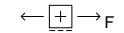
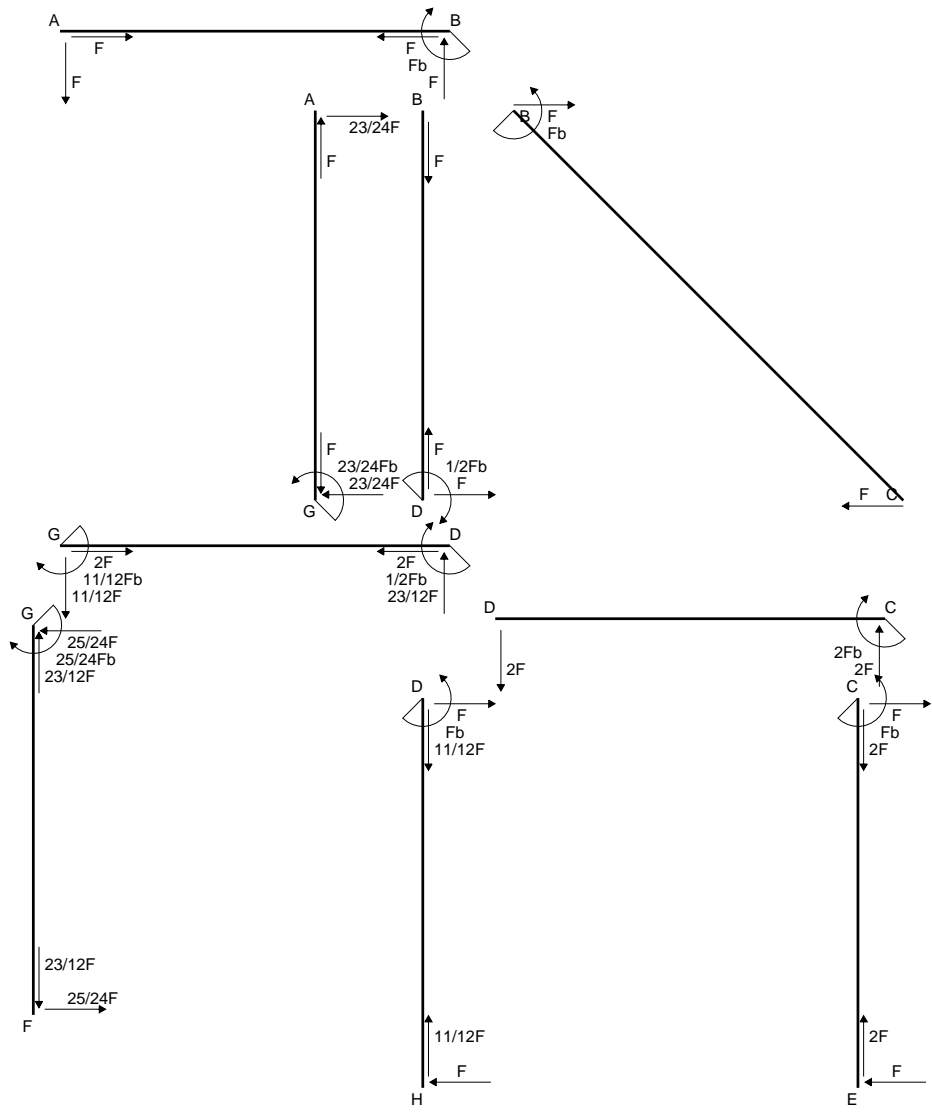

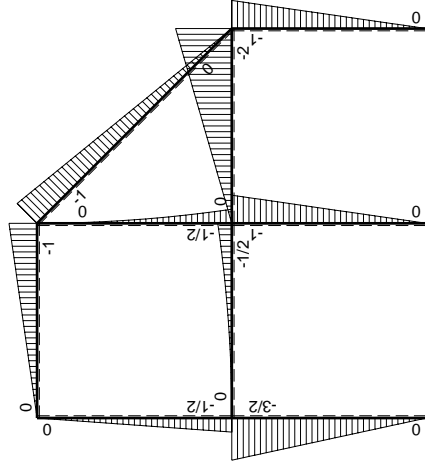
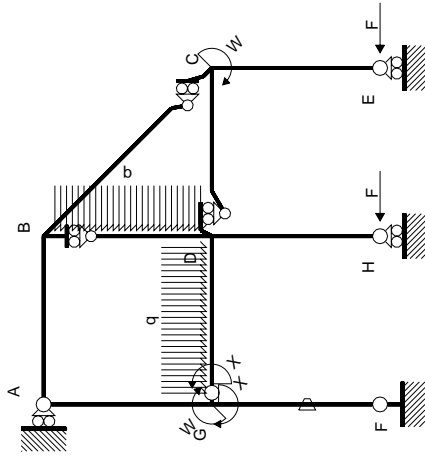

Schema di calcolo iperstatico

M_0 flessione da carichi assegnati

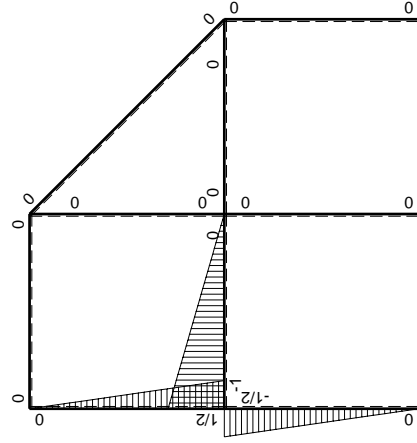

M_x flessione da iperstatica $X=1$

Quadro contributi PLV per iperstatica $X=W_{GD}$

→	$M_x(x)$	$M_o(x)$	θ	$M_x M_o$	$M_x \theta$	$M_x M_x$	$\int M_x(M_o/EJ+\theta)dx$	$\int X M_x M_x/EJ dx$
AB b	0	-Fx	0	0	0	0	0+0	0
BA b	0	Fb-Fx	0	0	0	0		
BC $\sqrt{2}b$	0	-Fb+ $\sqrt{2}/2Fx$	0	0	0	0	0	0
BD b	0	-1/2qx ²	0	0	0	0	0+0	0
DB b	0	1/2Fb-Fx+1/2qx ²	0	0	0	0		
DC b	0	-2Fx	0	0	0	0	0+0	0
CD b	0	2Fb-2Fx	0	0	0	0		
CE b	0	-Fb+Fx	0	0	0	0	0+0	0
EC b	0	Fx	0	0	0	0		
FG b	-1/2x/b	-3/2Fx	-Fb/EJ	3/4Fx ² /b	1/2Fx/EJ	1/4x ² /b ²	(1/4+1/4)Fb ² /EJ	1/12Xb/EJ
GF b	1/2-1/2x/b	3/2Fb-3/2Fx	Fb/EJ	3/4Fb-3/2Fx+3/4Fx ² /b	1/2Fb/EJ-1/2Fx/EJ	1/4-1/2x/b+1/4x ² /b ²		
GD b	-1+x/b	-1/2qx ²	0	1/2Fx ² /b-1/2qx ³ /b	0	1-2x/b+x ² /b ²	(1/24+0)Fb ² /EJ	1/3Xb/EJ
DG b	x/b	1/2Fb-Fx+1/2qx ²	0	1/2Fx-Fx ² /b+1/2qx ³ /b	0	x ² /b ²		
DH b	0	-Fb+Fx	0	0	0	0	0+0	0
HD b	0	Fx	0	0	0	0		
GA b	1/2-1/2x/b	-1/2Fb+1/2Fx	0	-1/4Fb+1/2Fx-1/4Fx ² /b	0	1/4-1/2x/b+1/4x ² /b ²	(-1/12+0)Fb ² /EJ	1/12Xb/EJ
AG b	-1/2x/b	1/2Fx	0	-1/4Fx ² /b	0	1/4x ² /b ²		
	totali						11/24Fb ² /EJ	1/2Xb/EJ
	iperstatica $X=W_{GD}$						-11/12Fb	

Sviluppi di calcolo iperstatica

$$L_{FG}^{xx} = \int_0^b (1/4 x^2/b^2) 1/EJ dx = [1/12 x^3/b^2]_0^b 1/EJ$$

$$= (1/12 b) 1/EJ = 1/12 b/EJ$$

$$L_{GF}^{xx} = \int_0^b (1/4 - 1/2 x/b + 1/4 x^2/b^2) 1/EJ dx = [1/4 x - 1/4 x^2/b + 1/12 x^3/b^2]_0^b 1/EJ$$

$$= (1/4 b - 1/4 b + 1/12 b) 1/EJ = 1/12 b/EJ$$

$$L_{GD}^{xx} = \int_0^b (1 - 2 x/b + x^2/b^2) 1/EJ dx = [x - x^2/b + 1/3 x^3/b^2]_0^b 1/EJ$$

$$= (b - b + 1/3 b) 1/EJ = 1/3 b/EJ$$

$$L_{DG}^{xx} = \int_0^b (x^2/b^2) 1/EJ dx = [1/3 x^3/b^2]_0^b 1/EJ$$

$$= (1/3 b) 1/EJ = 1/3 b/EJ$$

$$L_{GA}^{xx} = \int_0^b (1/4 - 1/2 x/b + 1/4 x^2/b^2) 1/EJ dx = [1/4 x - 1/4 x^2/b + 1/12 x^3/b^2]_0^b 1/EJ$$

$$= (1/4 b - 1/4 b + 1/12 b) 1/EJ = 1/12 b/EJ$$

$$L_{AG}^{xx} = \int_0^b (1/4 x^2/b^2) 1/EJ dx = [1/12 x^3/b^2]_0^b 1/EJ$$

$$= (1/12 b) 1/EJ = 1/12 b/EJ$$

$$L_{FG}^{xo} = \int_0^b (3/4 x^2/b^2) Fb 1/EJ dx + \int_0^b (1/2 x/b) \theta dx = [1/4 x^3/b^2]_0^b Fb 1/EJ + [1/4 x^2/b]_0^b \theta$$

$$= (1/4 b) Fb 1/EJ + (1/4 b) \theta = 1/2 Fb^2/EJ$$

$$L_{GF}^{xo} = \int_0^b (3/4 - 3/2 x/b + 3/4 x^2/b^2) Fb 1/EJ dx + \int_0^b (-1/2 + 1/2 x/b) \theta dx$$

$$= [3/4 x - 3/4 x^2/b + 1/4 x^3/b^2]_0^b Fb 1/EJ + [-1/2 x + 1/4 x^2/b]_0^b \theta$$

$$= (3/4 b - 3/4 b + 1/4 b) Fb 1/EJ + (-1/2 b + 1/4 b) \theta = 1/2 Fb^2/EJ$$

$$L_{GD}^{xo} = \int_0^b (1/2 x^2/b^2 - 1/2 x^3/b^3) Fb 1/EJ dx = [1/6 x^3/b^2 - 1/8 x^4/b^3]_0^b Fb 1/EJ$$

$$= (1/6 b - 1/8 b) Fb 1/EJ = 1/24 Fb^2/EJ$$

$$L_{DG}^{xo} = \int_0^b (1/2 x/b - x^2/b^2 + 1/2 x^3/b^3) Fb 1/EJ dx = [1/4 x^2/b - 1/3 x^3/b^2 + 1/8 x^4/b^3]_0^b Fb 1/EJ$$

$$= (1/4 b - 1/3 b + 1/8 b) Fb 1/EJ = 1/24 Fb^2/EJ$$

$$L_{GA}^{xo} = \int_0^b (-1/4 + 1/2 x/b - 1/4 x^2/b^2) Fb 1/EJ dx = [-1/4 x + 1/4 x^2/b - 1/12 x^3/b^2]_0^b Fb 1/EJ$$

$$= (-1/4 b + 1/4 b - 1/12 b) Fb 1/EJ = -1/12 Fb^2/EJ$$

$$L_{AG}^{xo} = \int_0^b (-1/4 x^2/b^2) Fb 1/EJ dx = [-1/12 x^3/b^2]_0^b Fb 1/EJ$$

$$= (-1/12 b) Fb 1/EJ = -1/12 Fb^2/EJ$$

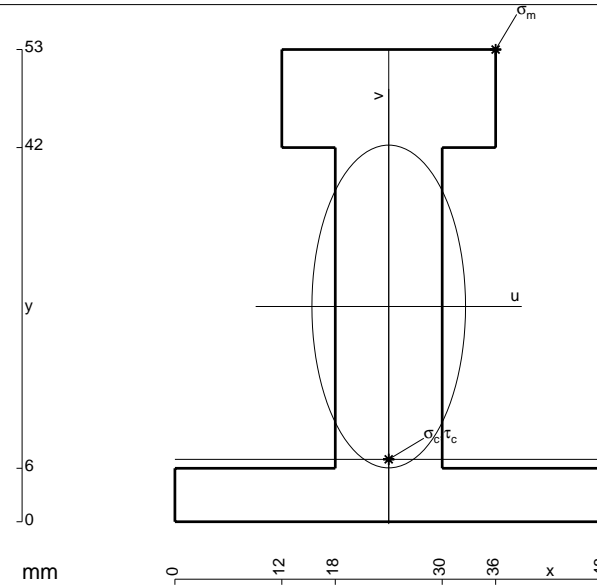

- A = 984. mm²
- J_u = 322959. mm⁴
- J_v = 73152. mm⁴
- y_g = 24.16 mm
- T_y = -4460. N
- M_x = -2230000. Nmm
- x_m = 36. mm
- y_m = 53. mm
- u_m = 12. mm
- v_m = 28.84 mm
- σ_m = -Mv/J_u = 199.1 N/mm²
- x_c = 24. mm
- y_c = 7. mm
- v_c = -17.16 mm
- σ_c = -Mv/J_u = -118.5 N/mm²
- τ_c = 7.257 N/mm²
- σ_q = √σ²+3τ² = 119.1 N/mm²
- S = 6306. mm³

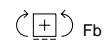
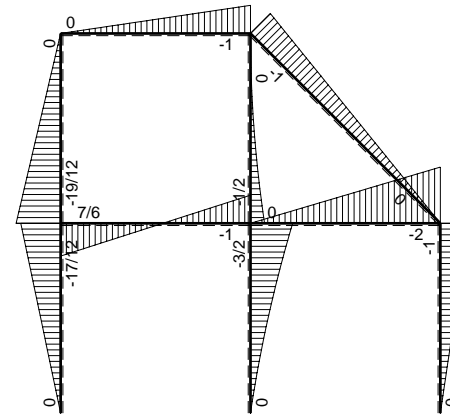
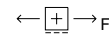
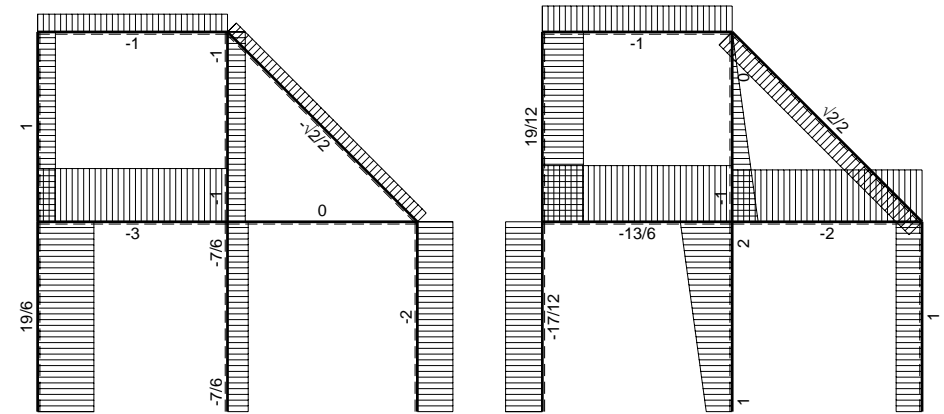
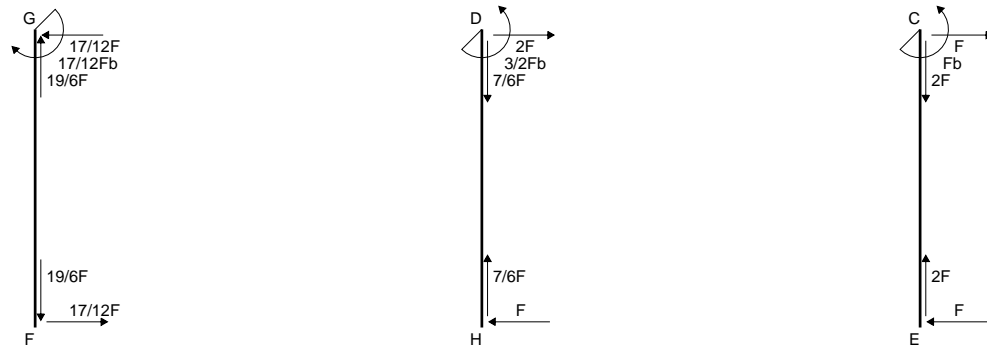
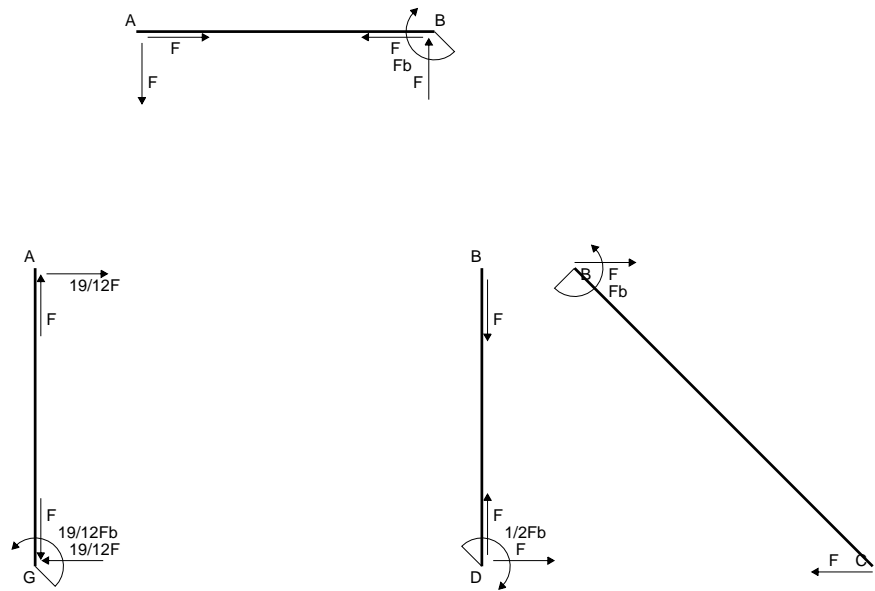

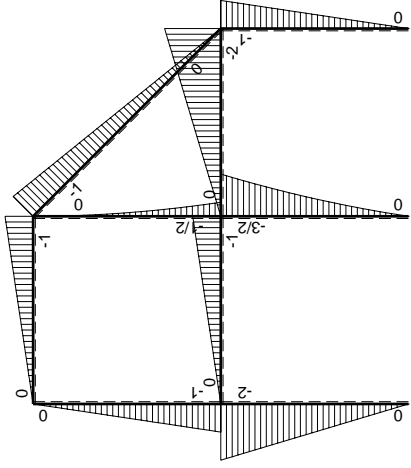
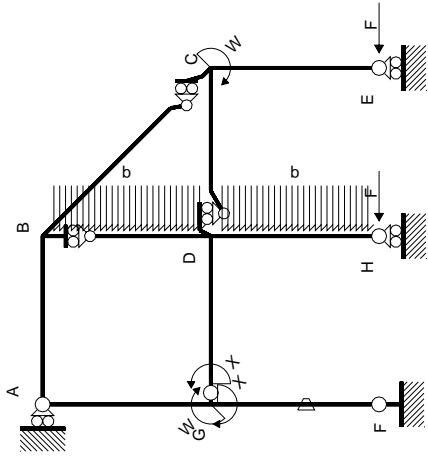

Schema di calcolo iperstatico

M_0 flessione da carichi assegnati

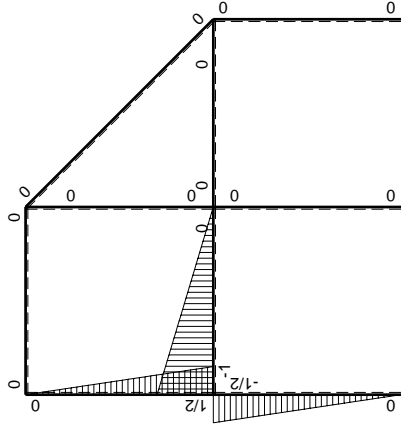

M_x flessione da iperstatica $X=1$

Quadro contributi PLV per iperstatica $X=W_{GD}$

→	$M_x(x)$	$M_o(x)$	θ	$M_x M_o$	$M_x \theta$	$M_x M_x$	$\int M_x(M_o/EJ+\theta)dx$	$\int X M_x M_x/EJ dx$
AB b	0	-Fx	0	0	0	0	0+0	0
BA b	0	Fb-Fx	0	0	0	0	0	0
BC $\sqrt{2}b$	0	-Fb+ $\sqrt{2}/2Fx$	0	0	0	0	0	0
BD b	0	-1/2qx ²	0	0	0	0	0+0	0
DB b	0	1/2Fb-Fx+1/2qx ²	0	0	0	0	0	0
DC b	0	-2Fx	0	0	0	0	0+0	0
CD b	0	2Fb-2Fx	0	0	0	0	0	0
CE b	0	-Fb+Fx	0	0	0	0	0+0	0
EC b	0	Fx	0	0	0	0	0	0
FG b	-1/2x/b	-2Fx	-Fb/EJ	Fx ² /b	1/2Fx/EJ	1/4x ² /b ²	(1/3+1/4)Fb ² /EJ	1/12Xb/EJ
GF b	1/2-1/2x/b	2Fb-2Fx	Fb/EJ	Fb-2Fx+Fx ² /b	1/2Fb/EJ-1/2Fx/EJ	1/4-1/2x/b+1/4x ² /b ²		
GD b	-1+x/b	-Fx	0	Fx-Fx ² /b	0	1-2x/b+x ² /b ²	(1/6+0)Fb ² /EJ	1/3Xb/EJ
DG b	x/b	Fb-Fx	0	Fx-Fx ² /b	0	x ² /b ²		
DH b	0	-3/2Fb+2Fx-1/2qx ²	0	0	0	0	0+0	0
HD b	0	Fx+1/2qx ²	0	0	0	0	0	0
GA b	1/2-1/2x/b	-Fb+Fx	0	-1/2Fb+Fx-1/2Fx ² /b	0	1/4-1/2x/b+1/4x ² /b ²	(-1/6+0)Fb ² /EJ	1/12Xb/EJ
AG b	-1/2x/b	Fx	0	-1/2Fx ² /b	0	1/4x ² /b ²		
	totali						7/12Fb ² /EJ	1/2Xb/EJ
	iperstatica $X=W_{GD}$						-7/6Fb	

Sviluppi di calcolo iperstatica

$$L_{FG}^{xx} = \int_0^b (1/4 x^2/b^2) 1/EJ dx = [1/12 x^3/b^2]_0^b 1/EJ$$

$$= (1/12 b) 1/EJ = 1/12 b/EJ$$

$$L_{GF}^{xx} = \int_0^b (1/4 - 1/2 x/b + 1/4 x^2/b^2) 1/EJ dx = [1/4 x - 1/4 x^2/b + 1/12 x^3/b^2]_0^b 1/EJ$$

$$= (1/4 b - 1/4 b + 1/12 b) 1/EJ = 1/12 b/EJ$$

$$L_{GD}^{xx} = \int_0^b (1 - 2 x/b + x^2/b^2) 1/EJ dx = [x - x^2/b + 1/3 x^3/b^2]_0^b 1/EJ$$

$$= (b - b + 1/3 b) 1/EJ = 1/3 b/EJ$$

$$L_{DG}^{xx} = \int_0^b (x^2/b^2) 1/EJ dx = [1/3 x^3/b^2]_0^b 1/EJ$$

$$= (1/3 b) 1/EJ = 1/3 b/EJ$$

$$L_{GA}^{xx} = \int_0^b (1/4 - 1/2 x/b + 1/4 x^2/b^2) 1/EJ dx = [1/4 x - 1/4 x^2/b + 1/12 x^3/b^2]_0^b 1/EJ$$

$$= (1/4 b - 1/4 b + 1/12 b) 1/EJ = 1/12 b/EJ$$

$$L_{AG}^{xx} = \int_0^b (1/4 x^2/b^2) 1/EJ dx = [1/12 x^3/b^2]_0^b 1/EJ$$

$$= (1/12 b) 1/EJ = 1/12 b/EJ$$

$$L_{FG}^{xo} = \int_0^b (x^2/b^2) Fb 1/EJ dx + \int_0^b (1/2 x/b) \theta dx = [1/3 x^3/b^2]_0^b Fb 1/EJ + [1/4 x^2/b]_0^b \theta$$

$$= (1/3 b) Fb 1/EJ + (1/4 b) \theta = 7/12 Fb^2/EJ$$

$$L_{GF}^{xo} = \int_0^b (1 - 2 x/b + x^2/b^2) Fb 1/EJ dx + \int_0^b (-1/2 + 1/2 x/b) \theta dx$$

$$= [x - x^2/b + 1/3 x^3/b^2]_0^b Fb 1/EJ + [-1/2 x + 1/4 x^2/b]_0^b \theta$$

$$= (b - b + 1/3 b) Fb 1/EJ + (-1/2 b + 1/4 b) \theta = 7/12 Fb^2/EJ$$

$$L_{GD}^{xo} = \int_0^b (x/b - x^2/b^2) Fb 1/EJ dx = [1/2 x^2/b - 1/3 x^3/b^2]_0^b Fb 1/EJ$$

$$= (1/2 b - 1/3 b) Fb 1/EJ = 1/6 Fb^2/EJ$$

$$L_{DG}^{xo} = \int_0^b (x/b - x^2/b^2) Fb 1/EJ dx = [1/2 x^2/b - 1/3 x^3/b^2]_0^b Fb 1/EJ$$

$$= (1/2 b - 1/3 b) Fb 1/EJ = 1/6 Fb^2/EJ$$

$$L_{GA}^{xo} = \int_0^b (-1/2 + x/b - 1/2 x^2/b^2) Fb 1/EJ dx = [-1/2 x + 1/2 x^2/b - 1/6 x^3/b^2]_0^b Fb 1/EJ$$

$$= (-1/2 b + 1/2 b - 1/6 b) Fb 1/EJ = -1/6 Fb^2/EJ$$

$$L_{AG}^{xo} = \int_0^b (-1/2 x^2/b^2) Fb 1/EJ dx = [-1/6 x^3/b^2]_0^b Fb 1/EJ$$

$$= (-1/6 b) Fb 1/EJ = -1/6 Fb^2/EJ$$

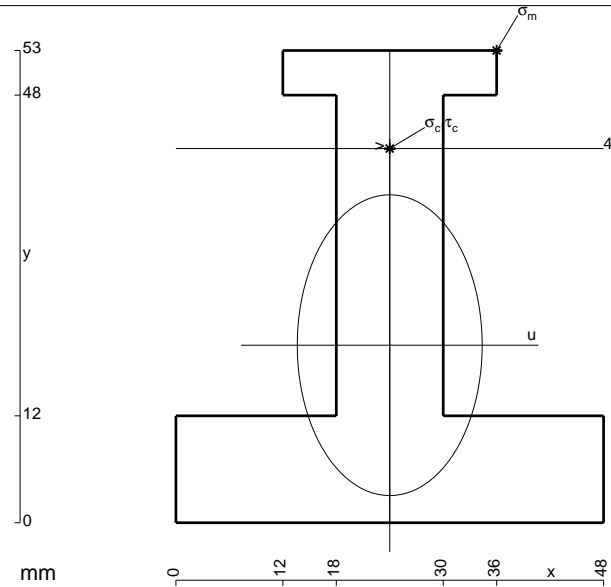

- A = 1128. mm²
- J_u = 321538. mm⁴
- J_v = 121536. mm⁴
- y_g = 19.93 mm
- T_y = -3700. N
- M_x = -2035000. Nmm
- x_m = 36. mm
- y_m = 53. mm
- u_m = 12. mm
- v_m = 33.07 mm
- σ_m = -Mv/J_u = 209.3 N/mm²
- x_c = 24. mm
- y_c = 42. mm
- v_c = 22.07 mm
- σ_c = -Mv/J_u = 139.7 N/mm²
- τ_c = 5.249 N/mm²
- σ_ρ = √(σ² + 3τ²) = 140. N/mm²
- S = 5474. mm³

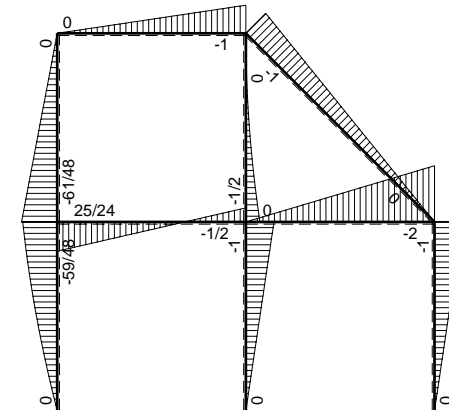
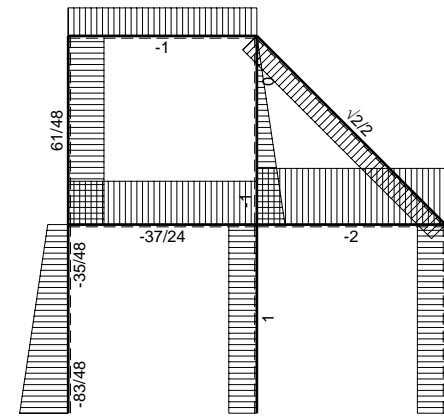
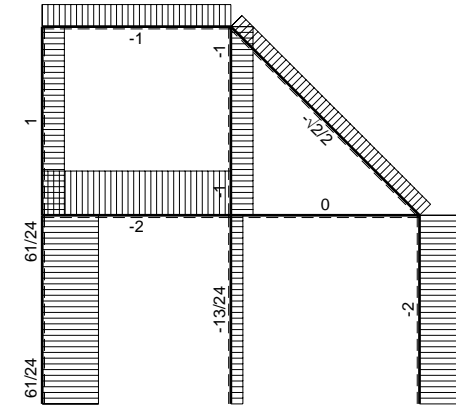
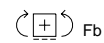
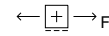
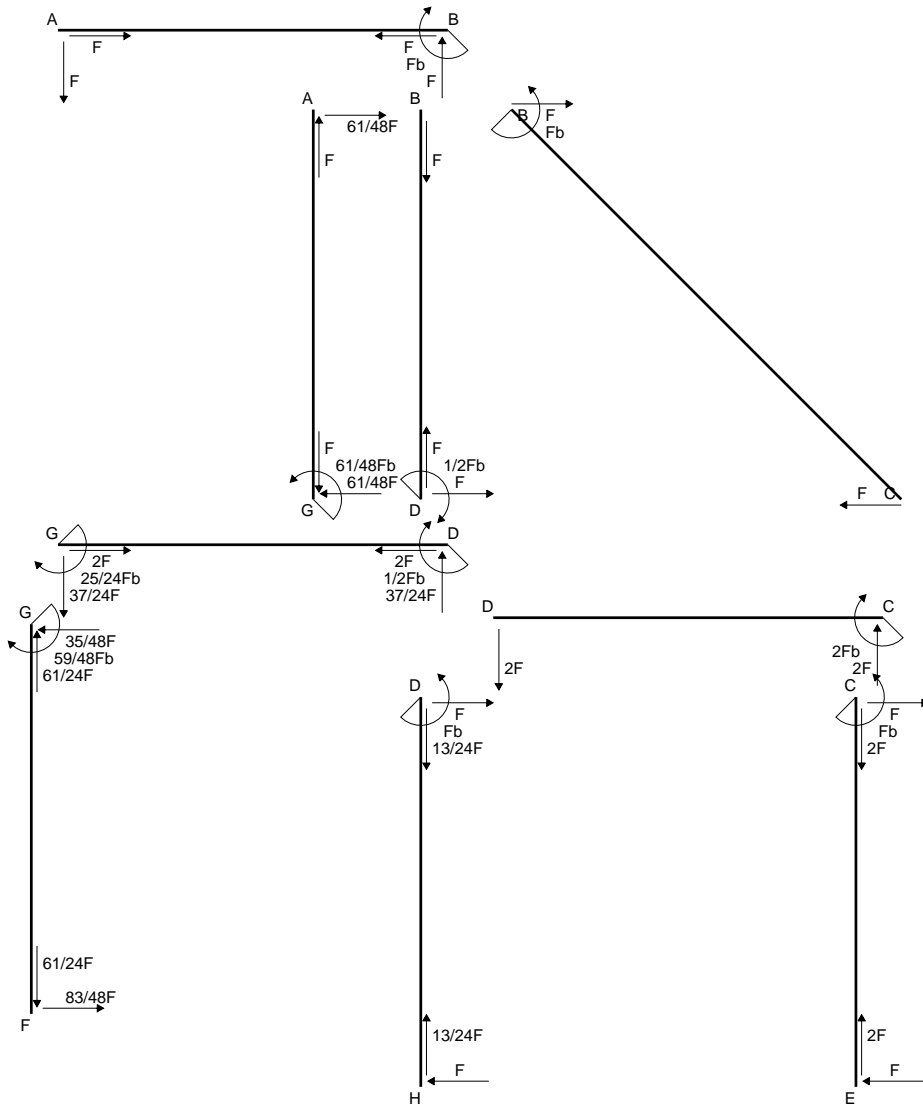

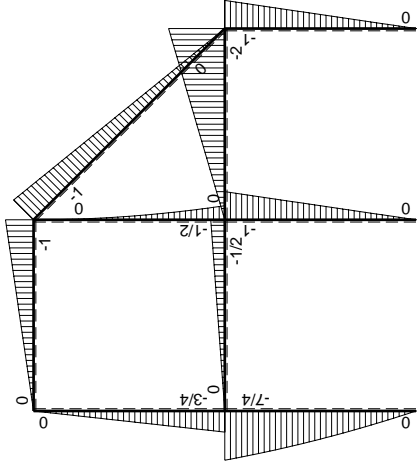
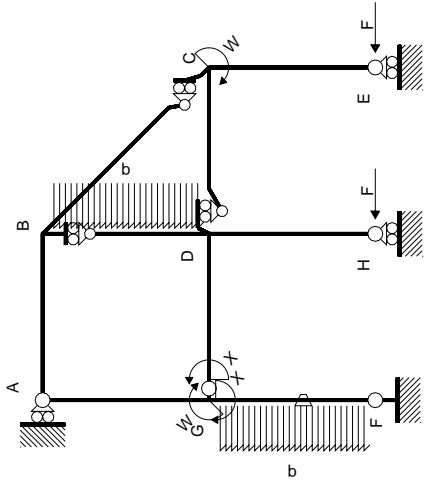

Schema di calcolo iperstatico

M_0 flessione da carichi assegnati

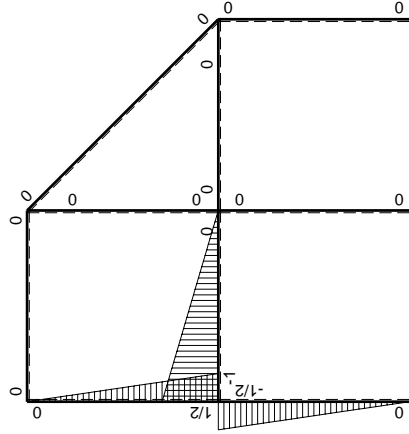

M_X flessione da iperstatica $X=1$

Quadro contributi PLV per iperstatica $X=W_{GD}$

→	$M_x(x)$	$M_o(x)$	θ	$M_x M_o$	$M_x \theta$	$M_x M_x$	$\int M_x(M_o/EJ+\theta)dx$	$\int X M_x M_x/EJdx$
AB b	0	-Fx	0	0	0	0	0+0	0
BA b	0	Fb-Fx	0	0	0	0	0	0
BC $\sqrt{2}b$	0	-Fb+ $\sqrt{2}/2Fx$	0	0	0	0	0	0
BD b	0	-1/2qx ²	0	0	0	0	0+0	0
DB b	0	1/2Fb-Fx+1/2qx ²	0	0	0	0	0	0
DC b	0	-2Fx	0	0	0	0	0+0	0
CD b	0	2Fb-2Fx	0	0	0	0	0	0
CE b	0	-Fb+Fx	0	0	0	0	0+0	0
EC b	0	Fx	0	0	0	0	0	0
FG b	-1/2x/b	-9/4Fx+1/2qx ²	-Fb/EJ	9/8Fx ² /b-1/4qx ³ /b	1/2Fx/EJ	1/4x ² /b ²	(5/16+1/4)Fb ² /EJ	1/12Xb/EJ
GF b	1/2-1/2x/b	7/4Fb-5/4Fx-1/2qx ²	Fb/EJ	7/8Fb-3/2Fx+3/8Fx ² /b+1/4qx ³ /b	1/2Fb/EJ-1/2Fx/EJ	1/4-1/2x/b+1/4x ² /b ²		
GD b	-1+x/b	-1/2Fx	0	1/2Fx-1/2Fx ² /b	0	1-2x/b+x ² /b ²	(1/12+0)Fb ² /EJ	1/3Xb/EJ
DG b	x/b	1/2Fb-1/2Fx	0	1/2Fx-1/2Fx ² /b	0	x ² /b ²		
DH b	0	-Fb+Fx	0	0	0	0	0+0	0
HD b	0	Fx	0	0	0	0	0	0
GA b	1/2-1/2x/b	-3/4Fb+3/4Fx	0	-3/8Fb+3/4Fx-3/8Fx ² /b	0	1/4-1/2x/b+1/4x ² /b ²	(-1/8+0)Fb ² /EJ	1/12Xb/EJ
AG b	-1/2x/b	3/4Fx	0	-3/8Fx ² /b	0	1/4x ² /b ²		
	totali						25/48Fb ² /EJ	1/2Xb/EJ
	iperstatica $X=W_{GD}$						-25/24Fb	

Sviluppi di calcolo iperstatica

$$L_{FG}^{xx} = \int_0^b (1/4 x^2/b^2) 1/EJ dx = [1/12 x^3/b^2]_0^b 1/EJ$$

$$= (1/12 b) 1/EJ = 1/12 b/EJ$$

$$L_{GF}^{xx} = \int_0^b (1/4 - 1/2 x/b + 1/4 x^2/b^2) 1/EJ dx = [1/4 x - 1/4 x^2/b + 1/12 x^3/b^2]_0^b 1/EJ$$

$$= (1/4 b - 1/4 b + 1/12 b) 1/EJ = 1/12 b/EJ$$

$$L_{GD}^{xx} = \int_0^b (1 - 2 x/b + x^2/b^2) 1/EJ dx = [x - x^2/b + 1/3 x^3/b^2]_0^b 1/EJ$$

$$= (b - b + 1/3 b) 1/EJ = 1/3 b/EJ$$

$$L_{DG}^{xx} = \int_0^b (x^2/b^2) 1/EJ dx = [1/3 x^3/b^2]_0^b 1/EJ$$

$$= (1/3 b) 1/EJ = 1/3 b/EJ$$

$$L_{GA}^{xx} = \int_0^b (1/4 - 1/2 x/b + 1/4 x^2/b^2) 1/EJ dx = [1/4 x - 1/4 x^2/b + 1/12 x^3/b^2]_0^b 1/EJ$$

$$= (1/4 b - 1/4 b + 1/12 b) 1/EJ = 1/12 b/EJ$$

$$L_{AG}^{xx} = \int_0^b (1/4 x^2/b^2) 1/EJ dx = [1/12 x^3/b^2]_0^b 1/EJ$$

$$= (1/12 b) 1/EJ = 1/12 b/EJ$$

$$L_{FG}^{xo} = \int_0^b (9/8 x^2/b^2 - 1/4 x^3/b^3) Fb 1/EJ dx + \int_0^b (1/2 x/b) \theta dx$$

$$= [3/8 x^3/b^2 - 1/16 x^4/b^3]_0^b Fb 1/EJ + [1/4 x^2/b]_0^b \theta$$

$$= (3/8 b - 1/16 b) Fb 1/EJ + (1/4 b) \theta = 9/16 Fb^2/EJ$$

$$L_{GF}^{xo} = \int_0^b (7/8 - 3/2 x/b + 3/8 x^2/b^2 + 1/4 x^3/b^3) Fb 1/EJ dx + \int_0^b (-1/2 + 1/2 x/b) \theta dx$$

$$= [7/8 x - 3/4 x^2/b + 1/8 x^3/b^2 + 1/16 x^4/b^3]_0^b Fb 1/EJ + [-1/2 x + 1/4 x^2/b]_0^b \theta$$

$$= (7/8 b - 3/4 b + 1/8 b + 1/16 b) Fb 1/EJ + (-1/2 b + 1/4 b) \theta = 9/16 Fb^2/EJ$$

$$L_{GD}^{xo} = \int_0^b (1/2 x/b - 1/2 x^2/b^2) Fb 1/EJ dx = [1/4 x^2/b - 1/6 x^3/b^2]_0^b Fb 1/EJ$$

$$= (1/4 b - 1/6 b) Fb 1/EJ = 1/12 Fb^2/EJ$$

$$L_{DG}^{xo} = \int_0^b (1/2 x/b - 1/2 x^2/b^2) Fb 1/EJ dx = [1/4 x^2/b - 1/6 x^3/b^2]_0^b Fb 1/EJ$$

$$= (1/4 b - 1/6 b) Fb 1/EJ = 1/12 Fb^2/EJ$$

$$L_{GA}^{xo} = \int_0^b (-3/8 + 3/4 x/b - 3/8 x^2/b^2) Fb 1/EJ dx = [-3/8 x + 3/8 x^2/b - 1/8 x^3/b^2]_0^b Fb 1/EJ$$

$$= (-3/8 b + 3/8 b - 1/8 b) Fb 1/EJ = -1/8 Fb^2/EJ$$

$$L_{AG}^{xo} = \int_0^b (-3/8 x^2/b^2) Fb 1/EJ dx = [-1/8 x^3/b^2]_0^b Fb 1/EJ$$

$$= (-1/8 b) Fb 1/EJ = -1/8 Fb^2/EJ$$

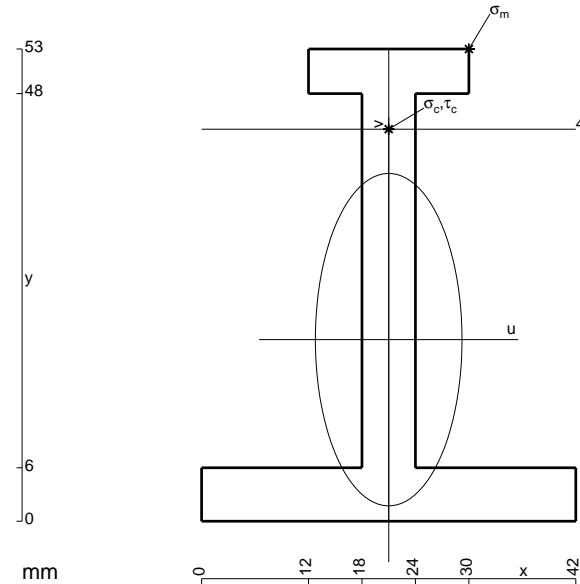

- A = 594. mm²
- J_u = 206801. mm⁴
- J_v = 40230. mm⁴
- y_g = 20.38 mm
- T_y = -2320. N
- M_x = -1392000. Nmm
- x_m = 30. mm
- y_m = 53. mm
- u_m = 9. mm
- v_m = 32.62 mm
- σ_m = -Mv/J_u = 219.6 N/mm²
- x_c = 21. mm
- y_c = 44. mm
- v_c = 23.62 mm
- σ_c = -Mv/J_v = 159. N/mm²
- τ_c = 6.218 N/mm²
- σ_o = √σ²+3τ² = 159.4 N/mm²
- S = 3326. mm³

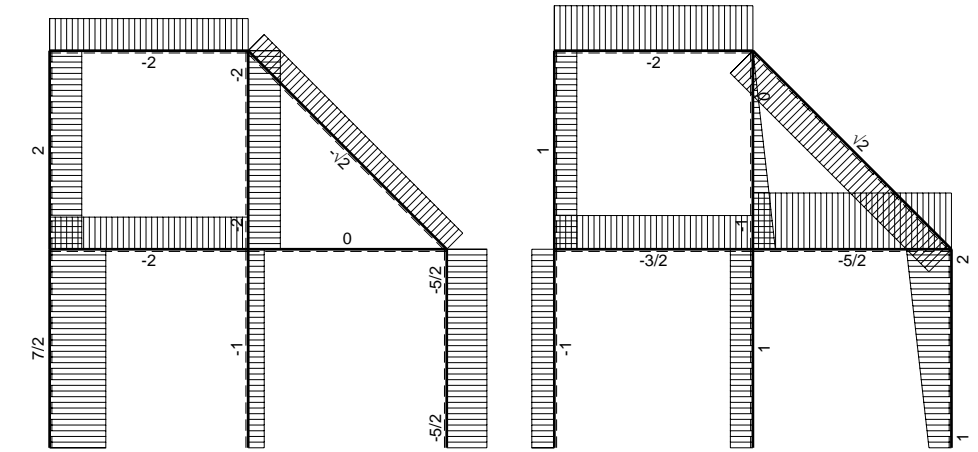
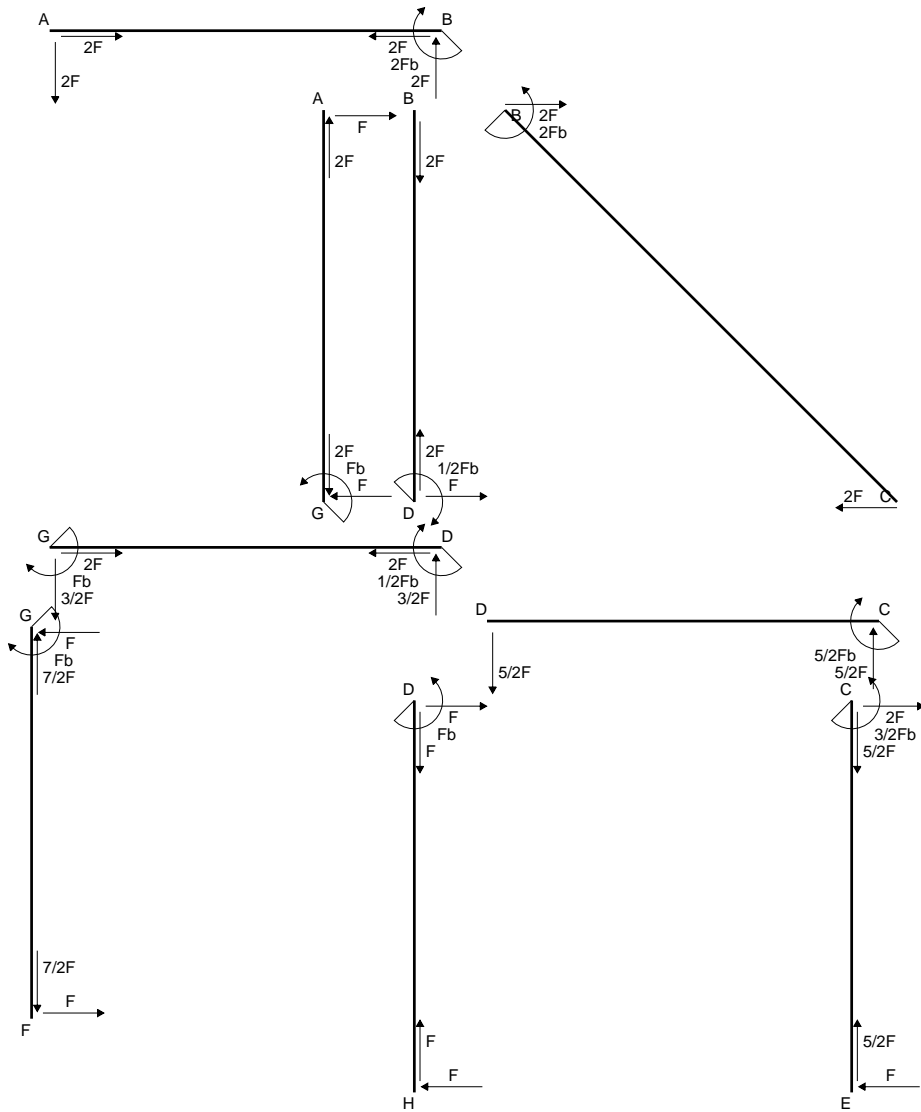

← + → F

↑ + ↓ F

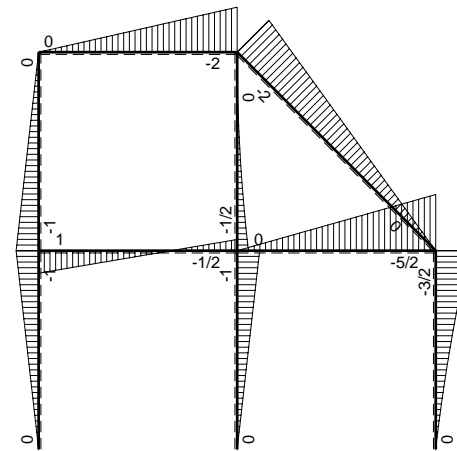

⤵ + ⤴ F_b

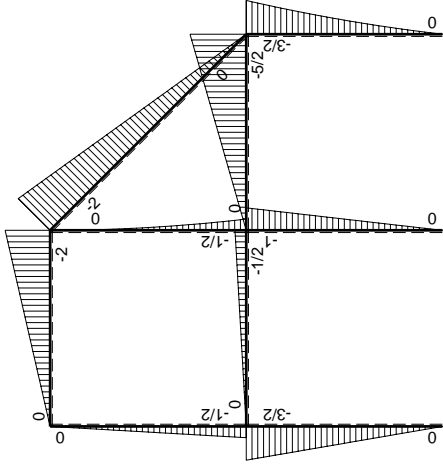
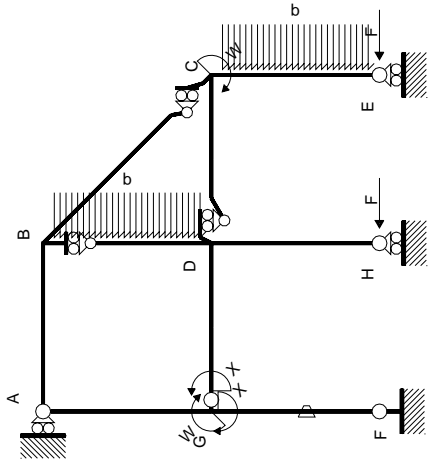

Schema di calcolo iperstatico

M_0 flessione da carichi assegnati

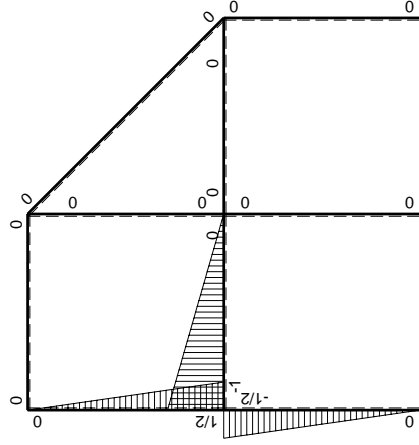

M_1 flessione da iperstatica $X=1$

Quadro contributi PLV per iperstatica $X=W_{GD}$

→	$M_x(x)$	$M_o(x)$	θ	$M_x M_o$	$M_x \theta$	$M_x M_x$	$\int M_x(M_o/EJ+\theta)dx$	$\int X M_x M_x / EJ dx$	
AB b	0	-2Fx	0	0	0	0	0+0	0	
BA b	0	2Fb-2Fx	0	0	0	0			
BC $\sqrt{2}b$	0	-2Fb+ $\sqrt{2}Fx$	0	0	0	0	0	0	
BD b	0	-1/2qx ²	0	0	0	0	0+0	0	
DB b	0	1/2Fb-Fx+1/2qx ²	0	0	0	0			
DC b	0	-5/2Fx	0	0	0	0	0+0	0	
CD b	0	5/2Fb-5/2Fx	0	0	0	0			
CE b	0	-3/2Fb+2Fx-1/2qx ²	0	0	0	0	0+0	0	
EC b	0	Fx+1/2qx ²	0	0	0	0			
FG b	-1/2x/b	-3/2Fx	-Fb/EJ	3/4Fx ² /b	1/2Fx/EJ	1/4x ² /b ²	(1/4+1/4)Fb ² /EJ	1/12Xb/EJ	
GF b	1/2-1/2x/b	3/2Fb-3/2Fx	Fb/EJ	3/4Fb-3/2Fx+3/4Fx ² /b	1/2Fb/EJ-1/2Fx/EJ	1/4-1/2x/b+1/4x ² /b ²			
GD b	-1+x/b	-1/2Fx	0	1/2Fx-1/2Fx ² /b	0	1-2x/b+x ² /b ²	(1/12+0)Fb ² /EJ	1/3Xb/EJ	
DG b	x/b	1/2Fb-1/2Fx	0	1/2Fx-1/2Fx ² /b	0	x ² /b ²			
DH b	0	-Fb+Fx	0	0	0	0	0+0	0	
HD b	0	Fx	0	0	0	0			
GA b	1/2-1/2x/b	-1/2Fb+1/2Fx	0	-1/4Fb+1/2Fx-1/4Fx ² /b	0	1/4-1/2x/b+1/4x ² /b ²	(-1/12+0)Fb ² /EJ	1/12Xb/EJ	
AG b	-1/2x/b	1/2Fx	0	-1/4Fx ² /b	0	1/4x ² /b ²			
	totali							1/2Fb ² /EJ	1/2Xb/EJ
	iperstatica $X=W_{GD}$							-Fb	

Sviluppi di calcolo iperstatica

$$L_{FG}^{xx} = \int_0^b (1/4 x^2/b^2) 1/EJ dx = [1/12 x^3/b^2]_0^b 1/EJ$$

$$= (1/12 b) 1/EJ = 1/12 b/EJ$$

$$L_{GF}^{xx} = \int_0^b (1/4 - 1/2 x/b + 1/4 x^2/b^2) 1/EJ dx = [1/4 x - 1/4 x^2/b + 1/12 x^3/b^2]_0^b 1/EJ$$

$$= (1/4 b - 1/4 b + 1/12 b) 1/EJ = 1/12 b/EJ$$

$$L_{GD}^{xx} = \int_0^b (1 - 2 x/b + x^2/b^2) 1/EJ dx = [x - x^2/b + 1/3 x^3/b^2]_0^b 1/EJ$$

$$= (b - b + 1/3 b) 1/EJ = 1/3 b/EJ$$

$$L_{DG}^{xx} = \int_0^b (x^2/b^2) 1/EJ dx = [1/3 x^3/b^2]_0^b 1/EJ$$

$$= (1/3 b) 1/EJ = 1/3 b/EJ$$

$$L_{GA}^{xx} = \int_0^b (1/4 - 1/2 x/b + 1/4 x^2/b^2) 1/EJ dx = [1/4 x - 1/4 x^2/b + 1/12 x^3/b^2]_0^b 1/EJ$$

$$= (1/4 b - 1/4 b + 1/12 b) 1/EJ = 1/12 b/EJ$$

$$L_{AG}^{xx} = \int_0^b (1/4 x^2/b^2) 1/EJ dx = [1/12 x^3/b^2]_0^b 1/EJ$$

$$= (1/12 b) 1/EJ = 1/12 b/EJ$$

$$L_{FG}^{xo} = \int_0^b (3/4 x^2/b^2) Fb 1/EJ dx + \int_0^b (1/2 x/b) \theta dx = [1/4 x^3/b^2]_0^b Fb 1/EJ + [1/4 x^2/b]_0^b \theta$$

$$= (1/4 b) Fb 1/EJ + (1/4 b) \theta = 1/2 Fb^2/EJ$$

$$L_{GF}^{xo} = \int_0^b (3/4 - 3/2 x/b + 3/4 x^2/b^2) Fb 1/EJ dx + \int_0^b (-1/2 + 1/2 x/b) \theta dx$$

$$= [3/4 x - 3/4 x^2/b + 1/4 x^3/b^2]_0^b Fb 1/EJ + [-1/2 x + 1/4 x^2/b]_0^b \theta$$

$$= (3/4 b - 3/4 b + 1/4 b) Fb 1/EJ + (-1/2 b + 1/4 b) \theta = 1/2 Fb^2/EJ$$

$$L_{GD}^{xo} = \int_0^b (1/2 x/b - 1/2 x^2/b^2) Fb 1/EJ dx = [1/4 x^2/b - 1/6 x^3/b^2]_0^b Fb 1/EJ$$

$$= (1/4 b - 1/6 b) Fb 1/EJ = 1/12 Fb^2/EJ$$

$$L_{DG}^{xo} = \int_0^b (1/2 x/b - 1/2 x^2/b^2) Fb 1/EJ dx = [1/4 x^2/b - 1/6 x^3/b^2]_0^b Fb 1/EJ$$

$$= (1/4 b - 1/6 b) Fb 1/EJ = 1/12 Fb^2/EJ$$

$$L_{GA}^{xo} = \int_0^b (-1/4 + 1/2 x/b - 1/4 x^2/b^2) Fb 1/EJ dx = [-1/4 x + 1/4 x^2/b - 1/12 x^3/b^2]_0^b Fb 1/EJ$$

$$= (-1/4 b + 1/4 b - 1/12 b) Fb 1/EJ = -1/12 Fb^2/EJ$$

$$L_{AG}^{xo} = \int_0^b (-1/4 x^2/b^2) Fb 1/EJ dx = [-1/12 x^3/b^2]_0^b Fb 1/EJ$$

$$= (-1/12 b) Fb 1/EJ = -1/12 Fb^2/EJ$$

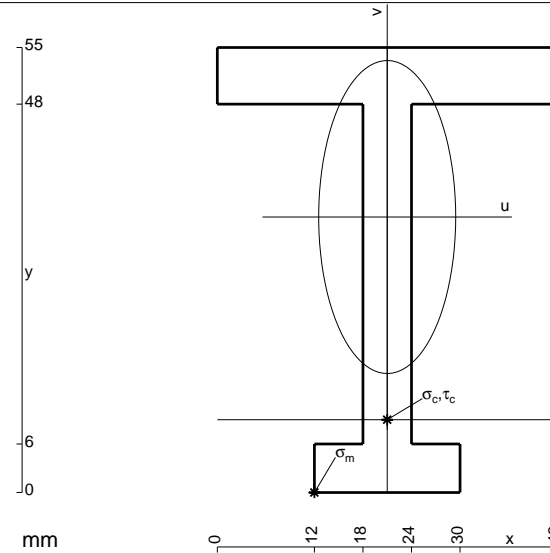

$$A = 654. \text{ mm}^2$$

$$J_u = 244740. \text{ mm}^4$$

$$J_v = 46890. \text{ mm}^4$$

$$y_g = 34.05 \text{ mm}$$

$$T_y = -2450. \text{ N}$$

$$M_x = -1641500. \text{ Nmm}$$

$$x_m = 12. \text{ mm}$$

$$u_m = -9. \text{ mm}$$

$$v_m = -34.05 \text{ mm}$$

$$\sigma_m = -Mv/J_u = -228.4 \text{ N/mm}^2$$

$$x_c = 21. \text{ mm}$$

$$y_c = 9. \text{ mm}$$

$$v_c = -25.05 \text{ mm}$$

$$\sigma_c = -Mv/J_u = -168. \text{ N/mm}^2$$

$$\tau_c = 6.392 \text{ N/mm}^2$$

$$\sigma_o = \sqrt{\sigma^2 + 3\tau^2} = 168.4 \text{ N/mm}^2$$

$$S = 3831. \text{ mm}^3$$

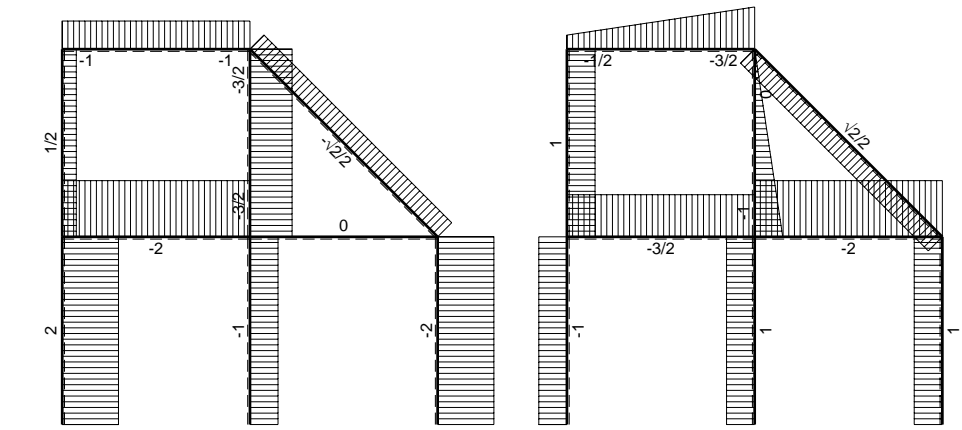
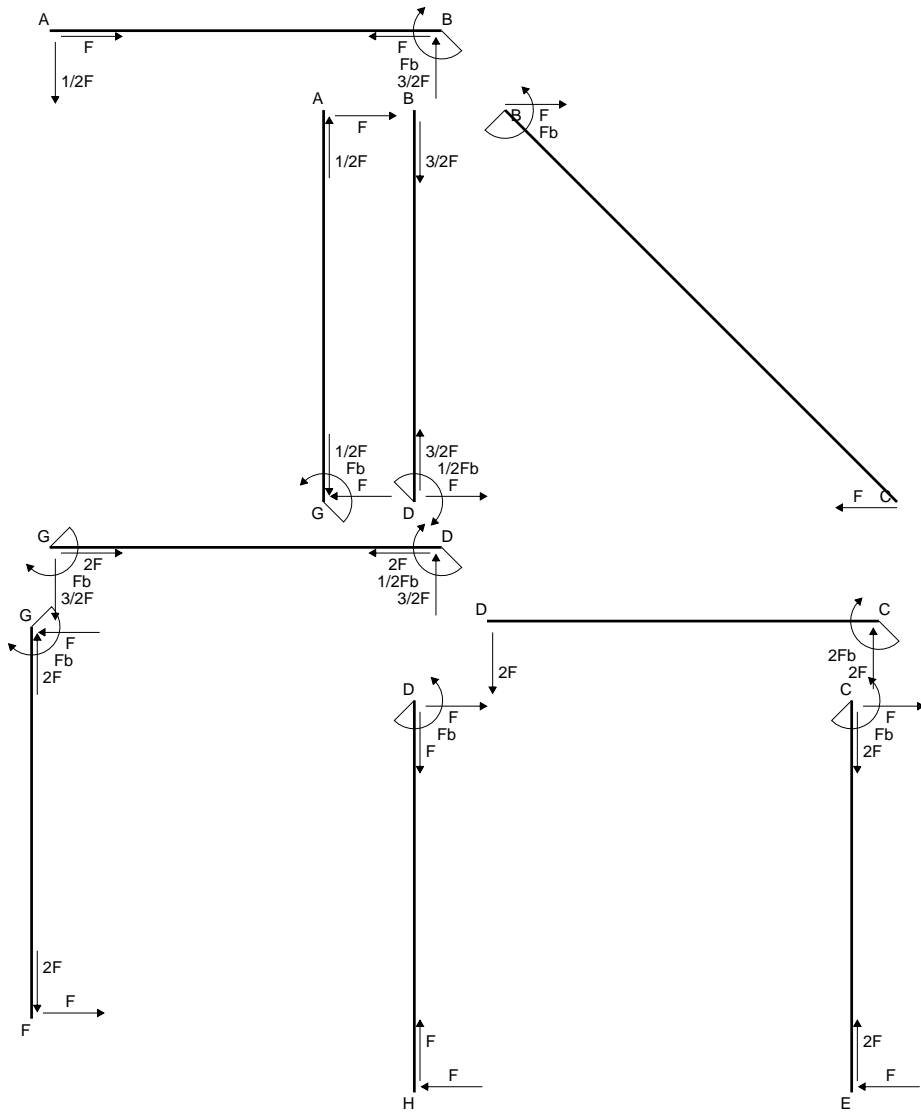

← ⊕ → F

↑ ⊕ ↓ F

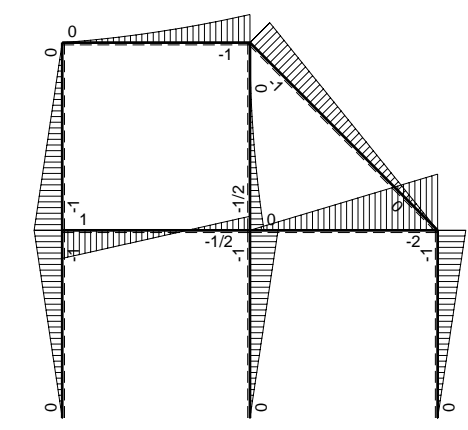

⊕ ⊖ Fb

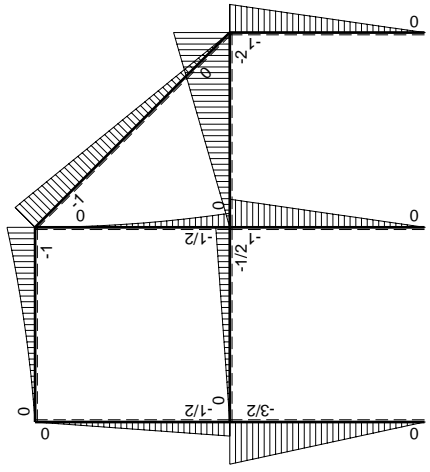
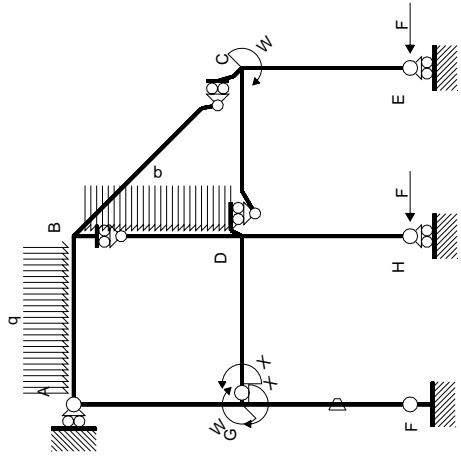

Schema di calcolo iperstatico

M_0 flessione da carichi assegnati

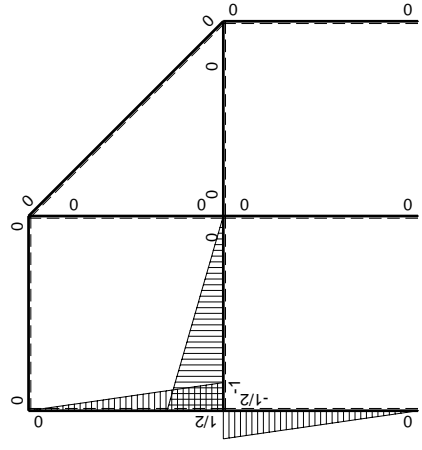

M_x flessione da iperstatica $X=1$

Quadro contributi PLV per iperstatica $X=W_{GD}$

→	$M_x(x)$	$M_o(x)$	θ	$M_x M_o$	$M_x \theta$	$M_x M_x$	$\int M_x(M_o/EJ+\theta)dx$	$\int X M_x M_x/EJdx$
AB b	0	$-1/2Fx-1/2qx^2$	0	0	0	0	0+0	0
BA b	0	$Fb-3/2Fx+1/2qx^2$	0	0	0	0		
BC $\sqrt{2}b$	0	$-Fb+\sqrt{2}/2Fx$	0	0	0	0	0	0
BD b	0	$-1/2qx^2$	0	0	0	0	0+0	0
DB b	0	$1/2Fb-Fx+1/2qx^2$	0	0	0	0		
DC b	0	$-2Fx$	0	0	0	0	0+0	0
CD b	0	$2Fb-2Fx$	0	0	0	0		
CE b	0	$-Fb+Fx$	0	0	0	0	0+0	0
EC b	0	Fx	0	0	0	0		
FG b	$-1/2x/b$	$-3/2Fx$	$-Fb/EJ$	$3/4Fx^2/b$	$1/2Fx/EJ$	$1/4x^2/b^2$	$(1/4+1/4)Fb^2/EJ$	$1/12Xb/EJ$
GF b	$1/2-1/2x/b$	$3/2Fb-3/2Fx$	Fb/EJ	$3/4Fb-3/2Fx+3/4Fx^2/b$	$1/2Fb/EJ-1/2Fx/EJ$	$1/4-1/2x/b+1/4x^2/b^2$		
GD b	$-1+x/b$	$-1/2Fx$	0	$1/2Fx-1/2Fx^2/b$	0	$1-2x/b+x^2/b^2$	$(1/12+0)Fb^2/EJ$	$1/3Xb/EJ$
DG b	x/b	$1/2Fb-1/2Fx$	0	$1/2Fx-1/2Fx^2/b$	0	x^2/b^2		
DH b	0	$-Fb+Fx$	0	0	0	0	0+0	0
HD b	0	Fx	0	0	0	0		
GA b	$1/2-1/2x/b$	$-1/2Fb+1/2Fx$	0	$-1/4Fb+1/2Fx-1/4Fx^2/b$	0	$1/4-1/2x/b+1/4x^2/b^2$	$(-1/12+0)Fb^2/EJ$	$1/12Xb/EJ$
AG b	$-1/2x/b$	$1/2Fx$	0	$-1/4Fx^2/b$	0	$1/4x^2/b^2$		
	totali						$1/2Fb^2/EJ$	$1/2Xb/EJ$
	iperstatica $X=W_{GD}$						$-Fb$	

Sviluppi di calcolo iperstatica

$$L_{FG}^{xx} = \int_0^b (1/4 x^2/b^2) 1/EJ dx = [1/12 x^3/b^2]_0^b 1/EJ$$

$$= (1/12 b) 1/EJ = 1/12 b/EJ$$

$$L_{GF}^{xx} = \int_0^b (1/4 - 1/2 x/b + 1/4 x^2/b^2) 1/EJ dx = [1/4 x - 1/4 x^2/b + 1/12 x^3/b^2]_0^b 1/EJ$$

$$= (1/4 b - 1/4 b + 1/12 b) 1/EJ = 1/12 b/EJ$$

$$L_{GD}^{xx} = \int_0^b (1 - 2 x/b + x^2/b^2) 1/EJ dx = [x - x^2/b + 1/3 x^3/b^2]_0^b 1/EJ$$

$$= (b - b + 1/3 b) 1/EJ = 1/3 b/EJ$$

$$L_{DG}^{xx} = \int_0^b (x^2/b^2) 1/EJ dx = [1/3 x^3/b^2]_0^b 1/EJ$$

$$= (1/3 b) 1/EJ = 1/3 b/EJ$$

$$L_{GA}^{xx} = \int_0^b (1/4 - 1/2 x/b + 1/4 x^2/b^2) 1/EJ dx = [1/4 x - 1/4 x^2/b + 1/12 x^3/b^2]_0^b 1/EJ$$

$$= (1/4 b - 1/4 b + 1/12 b) 1/EJ = 1/12 b/EJ$$

$$L_{AG}^{xx} = \int_0^b (1/4 x^2/b^2) 1/EJ dx = [1/12 x^3/b^2]_0^b 1/EJ$$

$$= (1/12 b) 1/EJ = 1/12 b/EJ$$

$$L_{FG}^{xo} = \int_0^b (3/4 x^2/b^2) Fb 1/EJ dx + \int_0^b (1/2 x/b) \theta dx = [1/4 x^3/b^2]_0^b Fb 1/EJ + [1/4 x^2/b]_0^b \theta$$

$$= (1/4 b) Fb 1/EJ + (1/4 b) \theta = 1/2 Fb^2/EJ$$

$$L_{GF}^{xo} = \int_0^b (3/4 - 3/2 x/b + 3/4 x^2/b^2) Fb 1/EJ dx + \int_0^b (-1/2 + 1/2 x/b) \theta dx$$

$$= [3/4 x - 3/4 x^2/b + 1/4 x^3/b^2]_0^b Fb 1/EJ + [-1/2 x + 1/4 x^2/b]_0^b \theta$$

$$= (3/4 b - 3/4 b + 1/4 b) Fb 1/EJ + (-1/2 b + 1/4 b) \theta = 1/2 Fb^2/EJ$$

$$L_{GD}^{xo} = \int_0^b (1/2 x/b - 1/2 x^2/b^2) Fb 1/EJ dx = [1/4 x^2/b - 1/6 x^3/b^2]_0^b Fb 1/EJ$$

$$= (1/4 b - 1/6 b) Fb 1/EJ = 1/12 Fb^2/EJ$$

$$L_{DG}^{xo} = \int_0^b (1/2 x/b - 1/2 x^2/b^2) Fb 1/EJ dx = [1/4 x^2/b - 1/6 x^3/b^2]_0^b Fb 1/EJ$$

$$= (1/4 b - 1/6 b) Fb 1/EJ = 1/12 Fb^2/EJ$$

$$L_{GA}^{xo} = \int_0^b (-1/4 + 1/2 x/b - 1/4 x^2/b^2) Fb 1/EJ dx = [-1/4 x + 1/4 x^2/b - 1/12 x^3/b^2]_0^b Fb 1/EJ$$

$$= (-1/4 b + 1/4 b - 1/12 b) Fb 1/EJ = -1/12 Fb^2/EJ$$

$$L_{AG}^{xo} = \int_0^b (-1/4 x^2/b^2) Fb 1/EJ dx = [-1/12 x^3/b^2]_0^b Fb 1/EJ$$

$$= (-1/12 b) Fb 1/EJ = -1/12 Fb^2/EJ$$

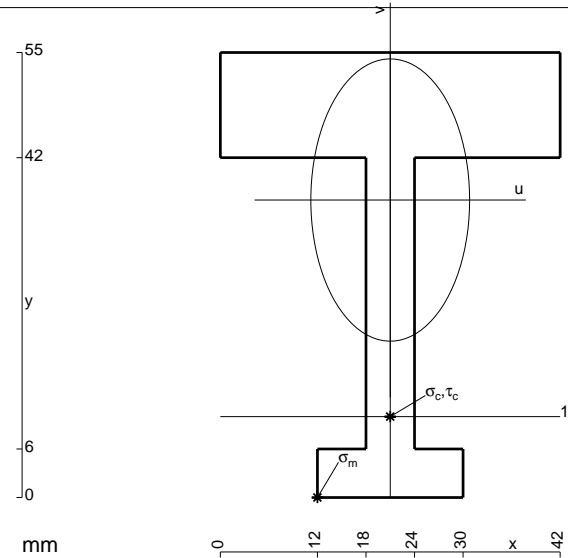

$$A = 870. \text{ mm}^2$$

$$J_u = 264856. \text{ mm}^4$$

$$J_v = 83826. \text{ mm}^4$$

$$y_g = 36.77 \text{ mm}$$

$$T_y = -2400. \text{ N}$$

$$M_x = -1728000. \text{ Nmm}$$

$$x_m = 12. \text{ mm}$$

$$u_m = -9. \text{ mm}$$

$$v_m = -36.77 \text{ mm}$$

$$\sigma_m = -Mv/J_u = -239.9 \text{ N/mm}^2$$

$$x_c = 21. \text{ mm}$$

$$y_c = 10. \text{ mm}$$

$$v_c = -26.77 \text{ mm}$$

$$\sigma_c = -Mv/J_u = -174.6 \text{ N/mm}^2$$

$$\tau_c = 6.551 \text{ N/mm}^2$$

$$\sigma_\rho = \sqrt{\sigma^2 + 3\tau^2} = 175. \text{ N/mm}^2$$

$$S = 4338. \text{ mm}^3$$

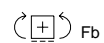
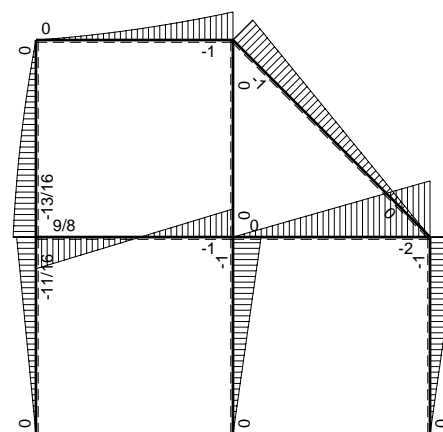
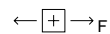
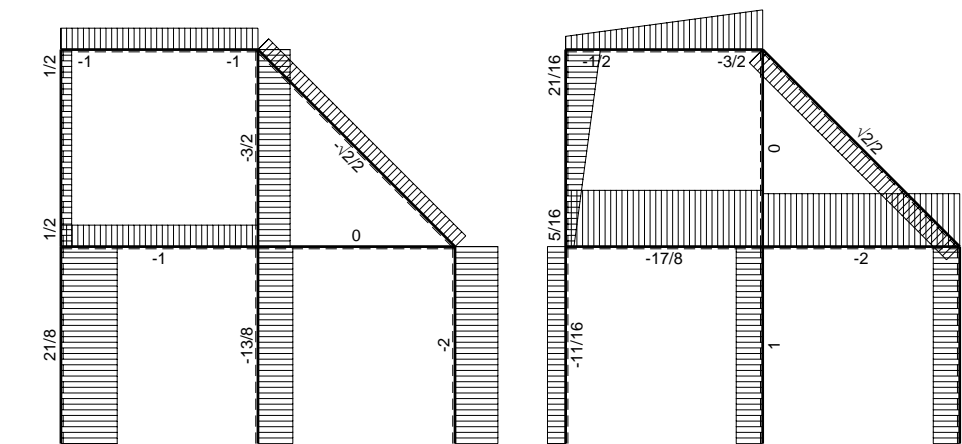
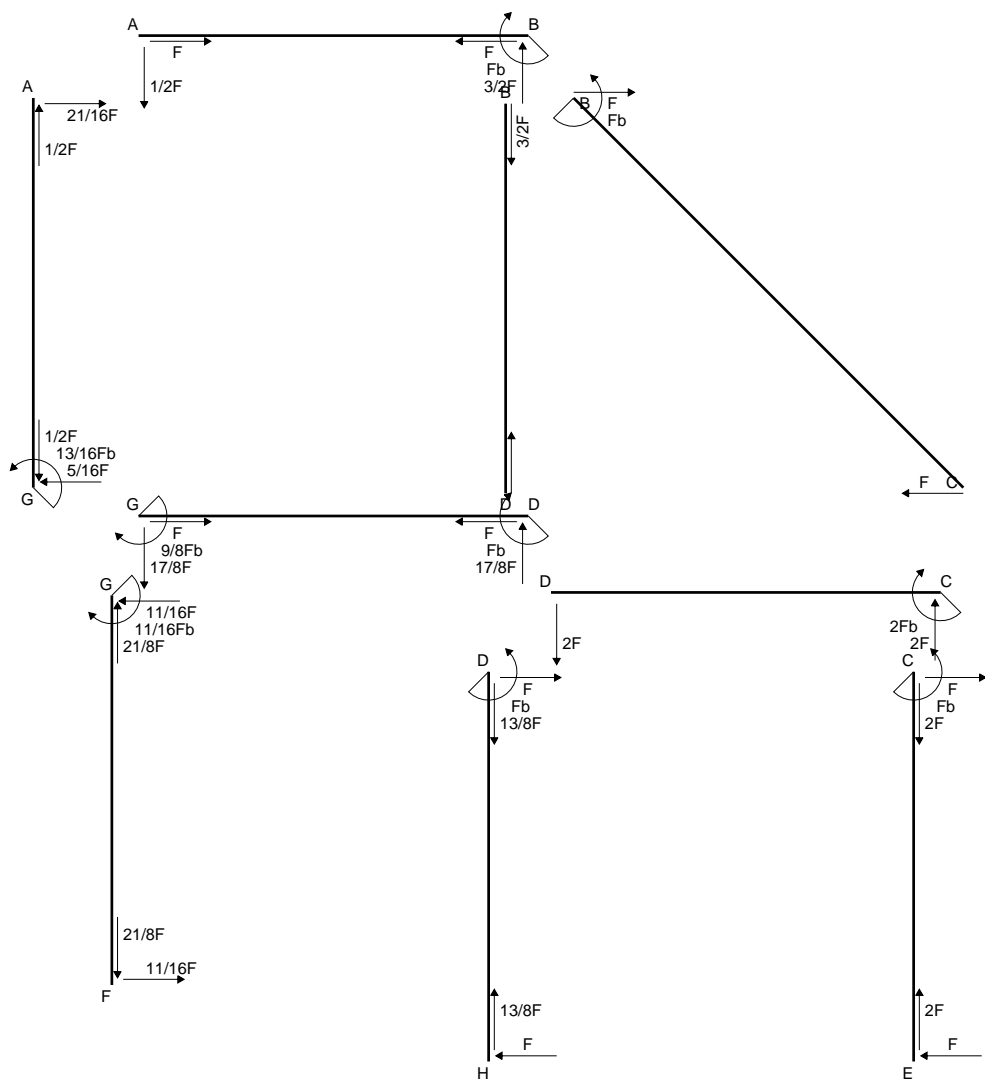

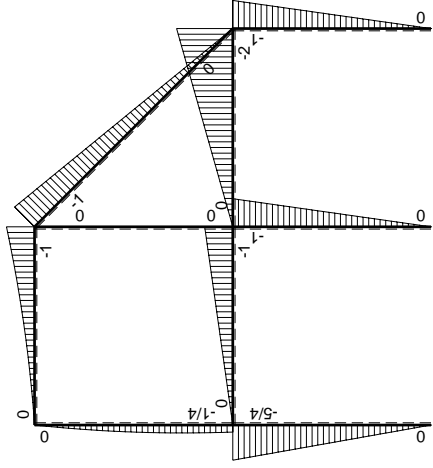
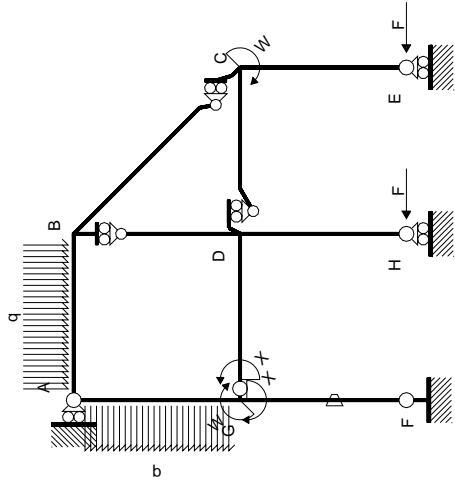

Schema di calcolo iperstatico

M_0 flessione da carichi assegnati

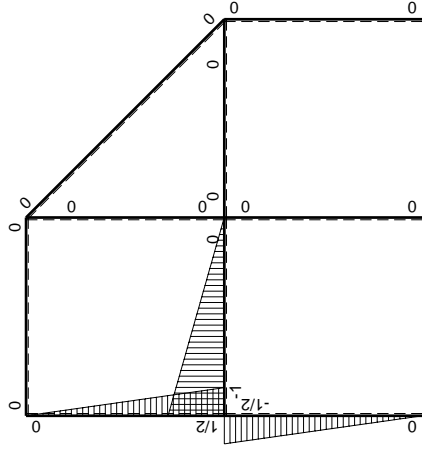

M_x flessione da iperstatica $X=1$

Quadro contributi PLV per iperstatica $X=W_{GD}$

→	$M_x(x)$	$M_o(x)$	θ	$M_x M_o$	$M_x \theta$	$M_x M_x$	$\int M_x(M_o/EJ+\theta)dx$	$\int X M_x M_x / EJ dx$	
AB b	0	$-1/2Fx - 1/2qx^2$	0	0	0	0	0+0	0	
BA b	0	$Fb - 3/2Fx + 1/2qx^2$	0	0	0	0	0	0	
BC $\sqrt{2}b$	0	$-Fb + \sqrt{2}/2Fx$	0	0	0	0	0	0	
BD b	0	0	0	0	0	0	0+0	0	
DB b	0	0	0	0	0	0	0	0	
DC b	0	$-2Fx$	0	0	0	0	0+0	0	
CD b	0	$2Fb - 2Fx$	0	0	0	0	0	0	
CE b	0	$-Fb + Fx$	0	0	0	0	0+0	0	
EC b	0	Fx	0	0	0	0	0	0	
FG b	$-1/2x/b$	$-5/4Fx$	$-Fb/EJ$	$5/8Fx^2/b$	$1/2Fx/EJ$	$1/4x^2/b^2$	$(5/24+1/4)Fb^2/EJ$	$1/12Xb/EJ$	
GF b	$1/2-1/2x/b$	$5/4Fb-5/4Fx$	Fb/EJ	$5/8Fb-5/4Fx+5/8Fx^2/b$	$1/2Fb/EJ-1/2Fx/EJ$	$1/4-1/2x/b+1/4x^2/b^2$			
GD b	$-1+x/b$	$-Fx$	0	$Fx-Fx^2/b$	0	$1-2x/b+x^2/b^2$	$(1/6+0)Fb^2/EJ$	$1/3Xb/EJ$	
DG b	x/b	$Fb-Fx$	0	$Fx-Fx^2/b$	0	x^2/b^2			
DH b	0	$-Fb+Fx$	0	0	0	0	0+0	0	
HD b	0	Fx	0	0	0	0	0	0	
GA b	$1/2-1/2x/b$	$-1/4Fb-1/4Fx+1/2qx^2$	0	$-1/8Fb+3/8Fx^2/b-1/4qx^3/b$	0	$1/4-1/2x/b+1/4x^2/b^2$	$(-1/16+0)Fb^2/EJ$	$1/12Xb/EJ$	
AG b	$-1/2x/b$	$3/4Fx-1/2qx^2$	0	$-3/8Fx^2/b+1/4qx^3/b$	0	$1/4x^2/b^2$			
	totali							$9/16Fb^2/EJ$	$1/2Xb/EJ$
	iperstatica $X=W_{GD}$							$-9/8Fb$	

Sviluppi di calcolo iperstatica

$$L_{FG}^{xx} = \int_0^b (1/4 x^2/b^2) 1/EJ dx = [1/12 x^3/b^2]_0^b 1/EJ$$

$$= (1/12 b) 1/EJ = 1/12 b/EJ$$

$$L_{GF}^{xx} = \int_0^b (1/4 - 1/2 x/b + 1/4 x^2/b^2) 1/EJ dx = [1/4 x - 1/4 x^2/b + 1/12 x^3/b^2]_0^b 1/EJ$$

$$= (1/4 b - 1/4 b + 1/12 b) 1/EJ = 1/12 b/EJ$$

$$L_{GD}^{xx} = \int_0^b (1 - 2 x/b + x^2/b^2) 1/EJ dx = [x - x^2/b + 1/3 x^3/b^2]_0^b 1/EJ$$

$$= (b - b + 1/3 b) 1/EJ = 1/3 b/EJ$$

$$L_{DG}^{xx} = \int_0^b (x^2/b^2) 1/EJ dx = [1/3 x^3/b^2]_0^b 1/EJ$$

$$= (1/3 b) 1/EJ = 1/3 b/EJ$$

$$L_{GA}^{xx} = \int_0^b (1/4 - 1/2 x/b + 1/4 x^2/b^2) 1/EJ dx = [1/4 x - 1/4 x^2/b + 1/12 x^3/b^2]_0^b 1/EJ$$

$$= (1/4 b - 1/4 b + 1/12 b) 1/EJ = 1/12 b/EJ$$

$$L_{AG}^{xx} = \int_0^b (1/4 x^2/b^2) 1/EJ dx = [1/12 x^3/b^2]_0^b 1/EJ$$

$$= (1/12 b) 1/EJ = 1/12 b/EJ$$

$$L_{FG}^{xo} = \int_0^b (5/8 x^2/b^2) Fb 1/EJ dx + \int_0^b (1/2 x/b) \theta dx = [5/24 x^3/b^2]_0^b Fb 1/EJ + [1/4 x^2/b]_0^b \theta$$

$$= (5/24 b) Fb 1/EJ + (1/4 b) \theta = 11/24 Fb^2/EJ$$

$$L_{GF}^{xo} = \int_0^b (5/8 - 5/4 x/b + 5/8 x^2/b^2) Fb 1/EJ dx + \int_0^b (-1/2 + 1/2 x/b) \theta dx$$

$$= [5/8 x - 5/8 x^2/b + 5/24 x^3/b^2]_0^b Fb 1/EJ + [-1/2 x + 1/4 x^2/b]_0^b \theta$$

$$= (5/8 b - 5/8 b + 5/24 b) Fb 1/EJ + (-1/2 b + 1/4 b) \theta = 11/24 Fb^2/EJ$$

$$L_{GD}^{xo} = \int_0^b (x/b - x^2/b^2) Fb 1/EJ dx = [1/2 x^2/b - 1/3 x^3/b^2]_0^b Fb 1/EJ$$

$$= (1/2 b - 1/3 b) Fb 1/EJ = 1/6 Fb^2/EJ$$

$$L_{DG}^{xo} = \int_0^b (x/b - x^2/b^2) Fb 1/EJ dx = [1/2 x^2/b - 1/3 x^3/b^2]_0^b Fb 1/EJ$$

$$= (1/2 b - 1/3 b) Fb 1/EJ = 1/6 Fb^2/EJ$$

$$L_{GA}^{xo} = \int_0^b (-1/8 + 3/8 x^2/b^2 - 1/4 x^3/b^3) Fb 1/EJ dx = [-1/8 x + 1/8 x^3/b^2 - 1/16 x^4/b^3]_0^b Fb 1/EJ$$

$$= (-1/8 b + 1/8 b - 1/16 b) Fb 1/EJ = -1/16 Fb^2/EJ$$

$$L_{AG}^{xo} = \int_0^b (-3/8 x^2/b^2 + 1/4 x^3/b^3) Fb 1/EJ dx = [-1/8 x^3/b^2 + 1/16 x^4/b^3]_0^b Fb 1/EJ$$

$$= (-1/8 b + 1/16 b) Fb 1/EJ = -1/16 Fb^2/EJ$$

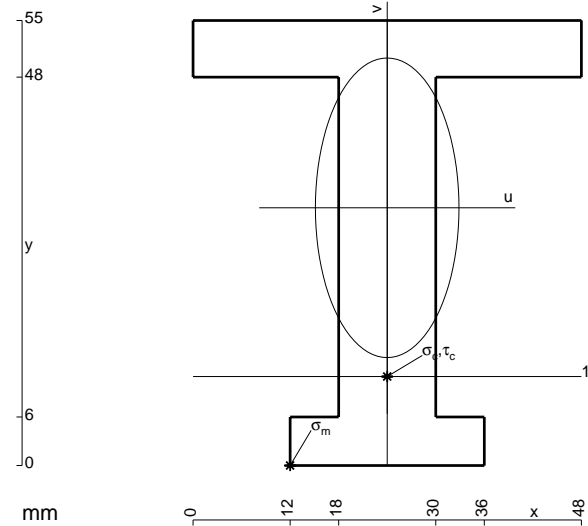

- A = 984. mm²
- J_u = 337339. mm⁴
- J_v = 77472. mm⁴
- y_g = 31.85 mm
- T_y = -2700. N
- M_x = -2106000. Nmm
- x_m = 12. mm
- u_m = -12. mm
- v_m = -31.85 mm
- σ_m = -Mv/J_u = -198.9 N/mm²
- x_c = 24. mm
- y_c = 11. mm
- v_c = -20.85 mm
- σ_c = -Mv/J_u = -130.2 N/mm²
- τ_c = 3.706 N/mm²
- σ_o = √σ²+3τ² = 130.3 N/mm²
- S = 5556. mm³

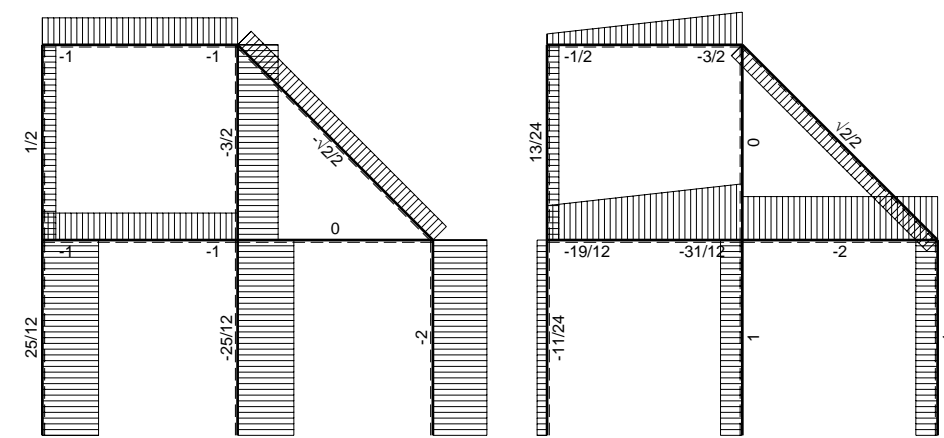
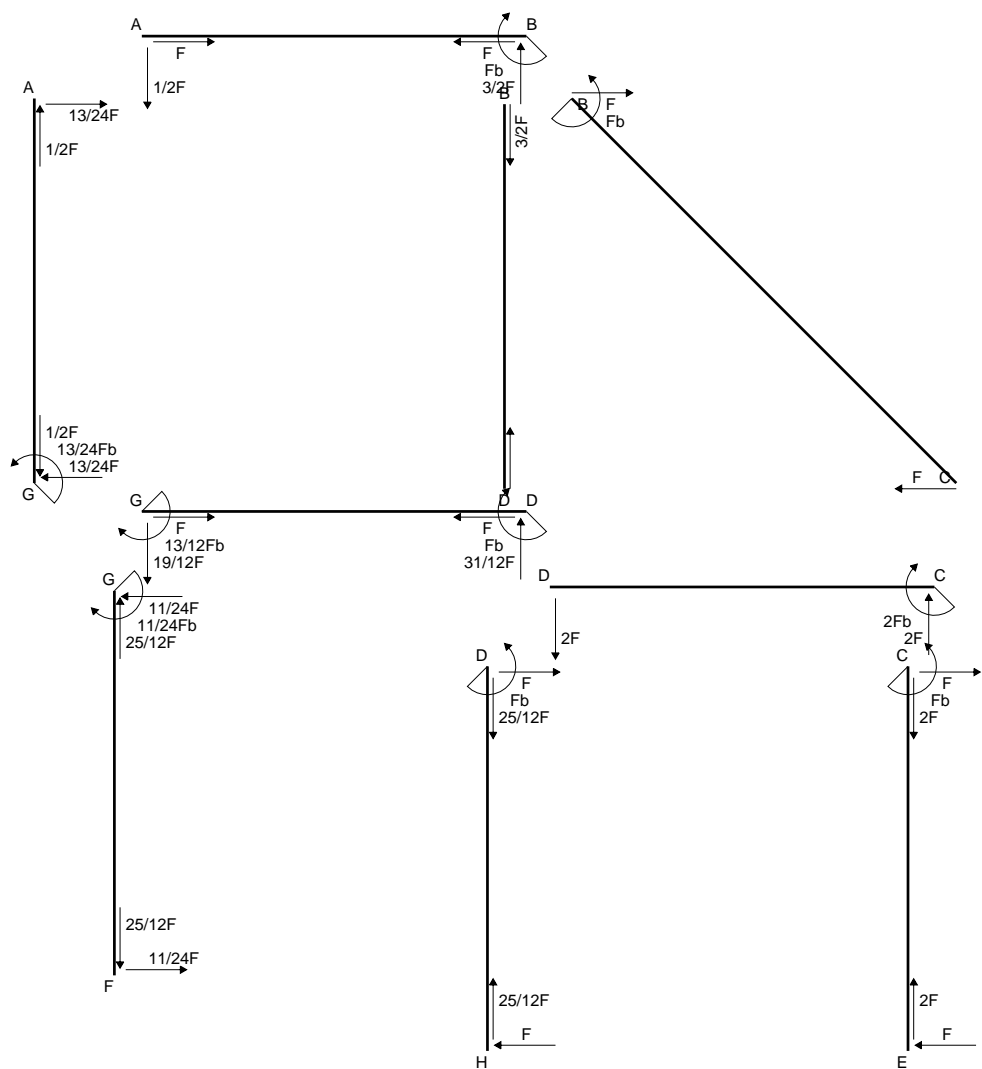

← + → F

↑ + ↓ F_b

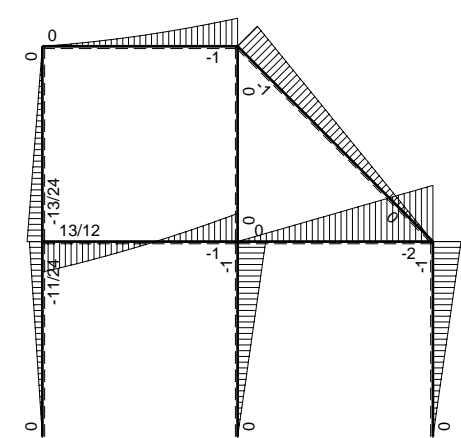

← + → F_b

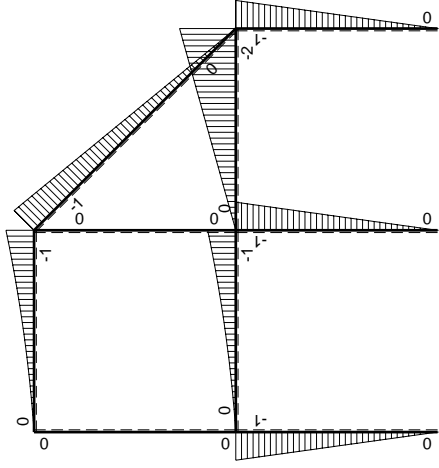
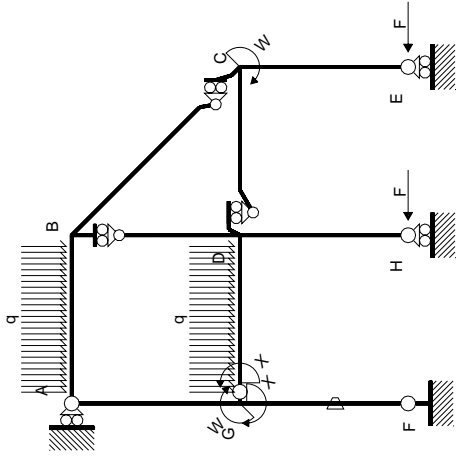

Schema di calcolo iperstatico

M_0 flessione da carichi assegnati

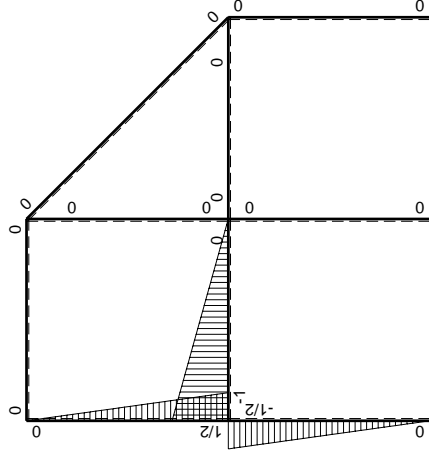

M_x flessione da iperstatica $X=1$

Quadro contributi PLV per iperstatica $X=W_{GD}$

→	$M_x(x)$	$M_o(x)$	θ	$M_x M_o$	$M_x \theta$	$M_x M_x$	$\int M_x(M_o/EJ+\theta)dx$	$\int X M_x M_x/EJdx$	
AB b	0	$-1/2Fx-1/2qx^2$	0	0	0	0	0+0	0	
BA b	0	$Fb-3/2Fx+1/2qx^2$	0	0	0	0	0	0	
BC $\sqrt{2}b$	0	$-Fb+\sqrt{2}/2Fx$	0	0	0	0	0	0	
BD b	0	0	0	0	0	0	0+0	0	
DB b	0	0	0	0	0	0	0	0	
DC b	0	$-2Fx$	0	0	0	0	0+0	0	
CD b	0	$2Fb-2Fx$	0	0	0	0	0	0	
CE b	0	$-Fb+Fx$	0	0	0	0	0+0	0	
EC b	0	Fx	0	0	0	0	0	0	
FG b	$-1/2x/b$	$-Fx$	$-Fb/EJ$	$1/2Fx^2/b$	$1/2Fx/EJ$	$1/4x^2/b^2$	$(1/6+1/4)Fb^2/EJ$	$1/12Xb/EJ$	
GF b	$1/2-1/2x/b$	$Fb-Fx$	Fb/EJ	$1/2Fb-Fx+1/2Fx^2/b$	$1/2Fb/EJ-1/2Fx/EJ$	$1/4-1/2x/b+1/4x^2/b^2$			
GD b	$-1+x/b$	$-1/2Fx-1/2qx^2$	0	$1/2Fx-1/2qx^3/b$	0	$1-2x/b+x^2/b^2$	$(1/8+0)Fb^2/EJ$	$1/3Xb/EJ$	
DG b	x/b	$Fb-3/2Fx+1/2qx^2$	0	$Fx-3/2Fx^2/b+1/2qx^3/b$	0	x^2/b^2			
DH b	0	$-Fb+Fx$	0	0	0	0	0+0	0	
HD b	0	Fx	0	0	0	0	0	0	
GA b	$1/2-1/2x/b$	0	0	0	0	$1/4-1/2x/b+1/4x^2/b^2$	0+0	$1/12Xb/EJ$	
AG b	$-1/2x/b$	0	0	0	0	$1/4x^2/b^2$			
	totali							$13/24Fb^2/EJ$	$1/2Xb/EJ$
	iperstatica $X=W_{GD}$							$-13/12Fb$	

Sviluppi di calcolo iperstatica

$$L_{FG}^{xx} = \int_0^b (1/4 x^2/b^2) 1/EJ dx = [1/12 x^3/b^2]_0^b 1/EJ$$

$$= (1/12 b) 1/EJ = 1/12 b/EJ$$

$$L_{GF}^{xx} = \int_0^b (1/4 - 1/2 x/b + 1/4 x^2/b^2) 1/EJ dx = [1/4 x - 1/4 x^2/b + 1/12 x^3/b^2]_0^b 1/EJ$$

$$= (1/4 b - 1/4 b + 1/12 b) 1/EJ = 1/12 b/EJ$$

$$L_{GD}^{xx} = \int_0^b (1 - 2 x/b + x^2/b^2) 1/EJ dx = [x - x^2/b + 1/3 x^3/b^2]_0^b 1/EJ$$

$$= (b - b + 1/3 b) 1/EJ = 1/3 b/EJ$$

$$L_{DG}^{xx} = \int_0^b (x^2/b^2) 1/EJ dx = [1/3 x^3/b^2]_0^b 1/EJ$$

$$= (1/3 b) 1/EJ = 1/3 b/EJ$$

$$L_{GA}^{xx} = \int_0^b (1/4 - 1/2 x/b + 1/4 x^2/b^2) 1/EJ dx = [1/4 x - 1/4 x^2/b + 1/12 x^3/b^2]_0^b 1/EJ$$

$$= (1/4 b - 1/4 b + 1/12 b) 1/EJ = 1/12 b/EJ$$

$$L_{AG}^{xx} = \int_0^b (1/4 x^2/b^2) 1/EJ dx = [1/12 x^3/b^2]_0^b 1/EJ$$

$$= (1/12 b) 1/EJ = 1/12 b/EJ$$

$$L_{FG}^{xo} = \int_0^b (1/2 x^2/b^2) Fb 1/EJ dx + \int_0^b (1/2 x/b) \theta dx = [1/6 x^3/b^2]_0^b Fb 1/EJ + [1/4 x^2/b]_0^b \theta$$

$$= (1/6 b) Fb 1/EJ + (1/4 b) \theta = 5/12 Fb^2/EJ$$

$$L_{GF}^{xo} = \int_0^b (1/2 - x/b + 1/2 x^2/b^2) Fb 1/EJ dx + \int_0^b (-1/2 + 1/2 x/b) \theta dx$$

$$= [1/2 x - 1/2 x^2/b + 1/6 x^3/b^2]_0^b Fb 1/EJ + [-1/2 x + 1/4 x^2/b]_0^b \theta$$

$$= (1/2 b - 1/2 b + 1/6 b) Fb 1/EJ + (-1/2 b + 1/4 b) \theta = 5/12 Fb^2/EJ$$

$$L_{GD}^{xo} = \int_0^b (1/2 x/b - 1/2 x^3/b^3) Fb 1/EJ dx = [1/4 x^2/b - 1/8 x^4/b^3]_0^b Fb 1/EJ$$

$$= (1/4 b - 1/8 b) Fb 1/EJ = 1/8 Fb^2/EJ$$

$$L_{DG}^{xo} = \int_0^b (x/b - 3/2 x^2/b^2 + 1/2 x^3/b^3) Fb 1/EJ dx = [1/2 x^2/b - 1/2 x^3/b^2 + 1/8 x^4/b^3]_0^b Fb 1/EJ$$

$$= (1/2 b - 1/2 b + 1/8 b) Fb 1/EJ = 1/8 Fb^2/EJ$$

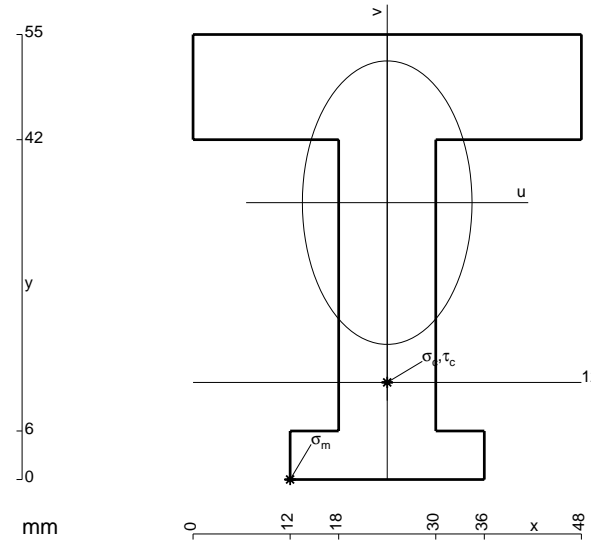

- A = 1200. mm²
- J_u = 368598. mm⁴
- J_v = 131904. mm⁴
- y_g = 34.22 mm
- T_y = -2720. N
- M_x = -2257600. Nmm
- x_m = 12. mm
- u_m = -12. mm
- v_m = -34.22 mm
- σ_m = -Mv/J_u = -209.6 N/mm²
- x_c = 24. mm
- y_c = 12. mm
- v_c = -22.22 mm
- σ_c = -Mv/J_u = -136.1 N/mm²
- τ_c = 3.881 N/mm²
- σ_o = √σ²+3τ² = 136.3 N/mm²
- S = 6312. mm³

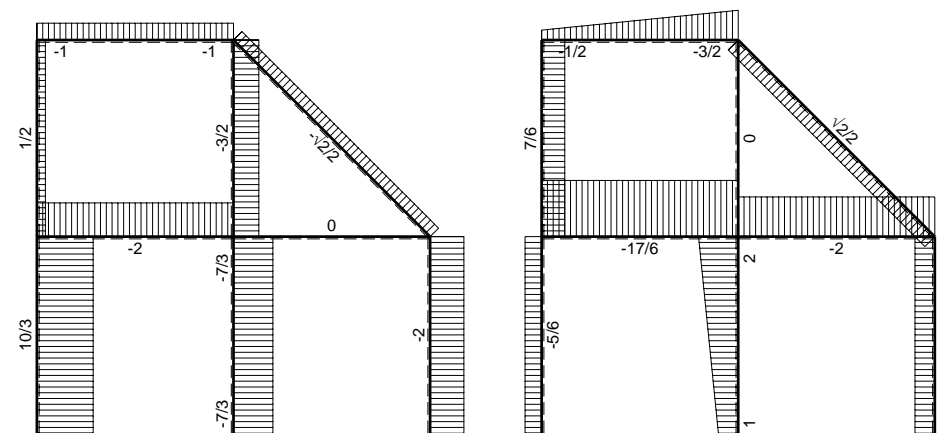
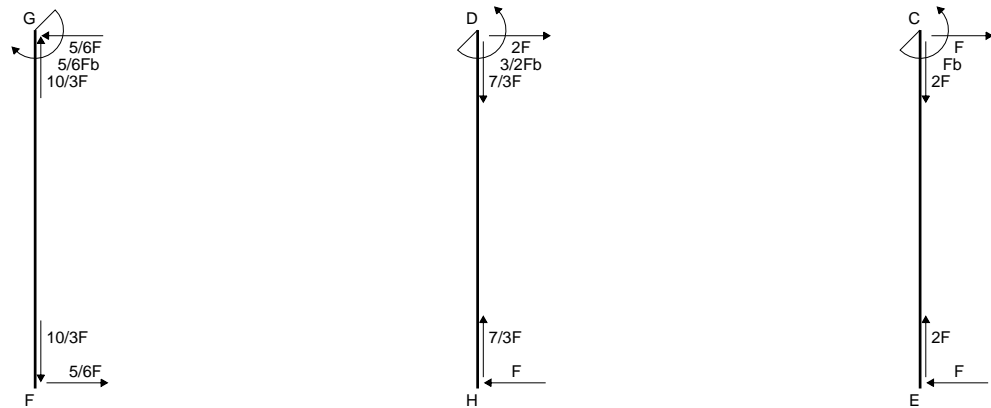
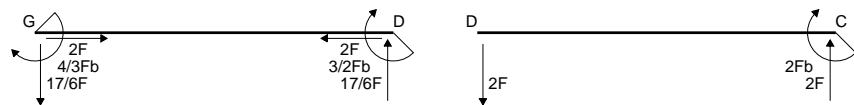
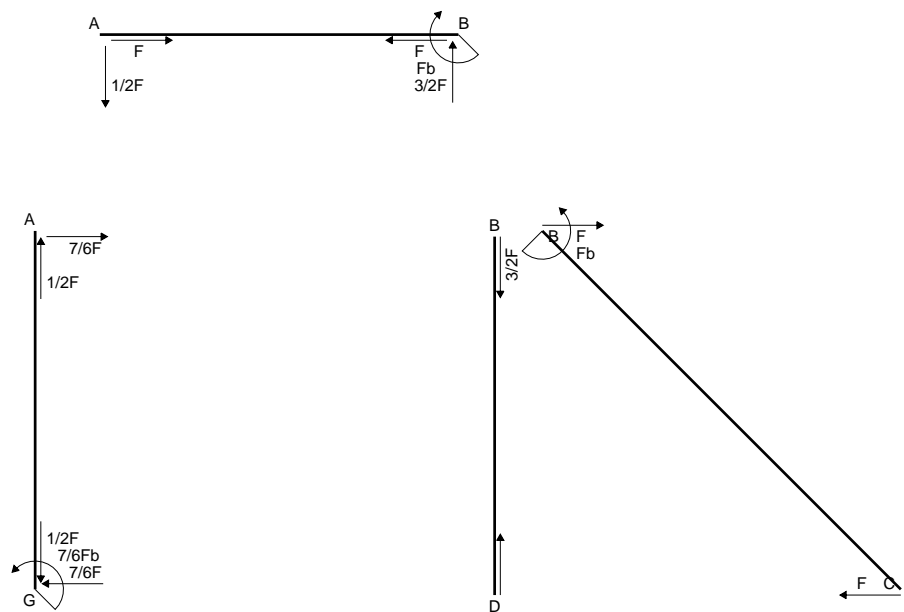

← ⊕ → F

↑ ⊕ ↓ F

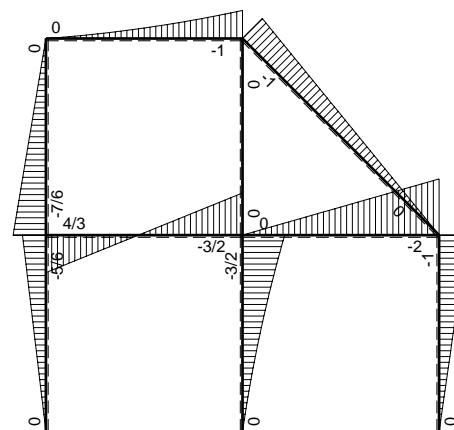

⊕ ⊖ Fb

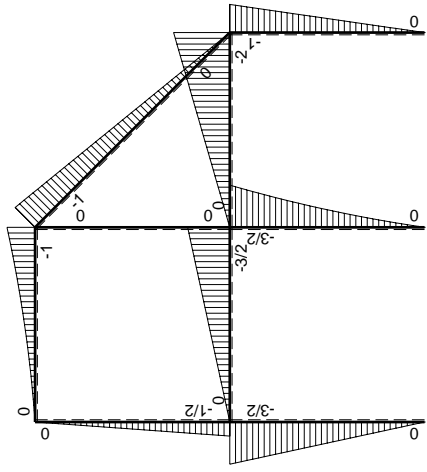
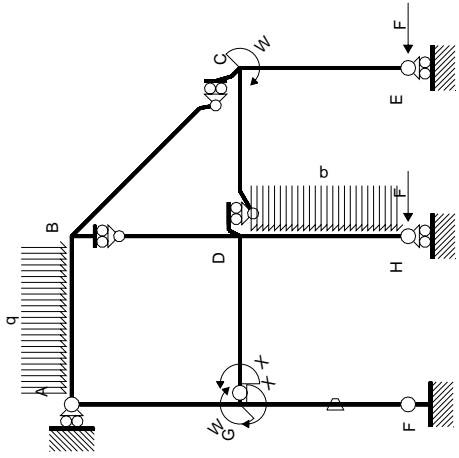

Schema di calcolo iperstatico

M_0 flessione da carichi assegnati

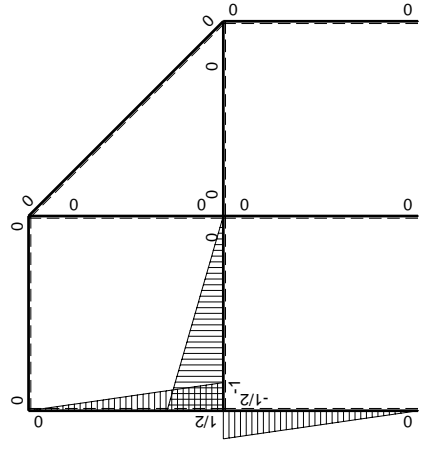

M_1 flessione da iperstatica $X=1$

Quadro contributi PLV per iperstatica $X=W_{GD}$

→	$M_x(x)$	$M_o(x)$	θ	$M_x M_o$	$M_x \theta$	$M_x M_x$	$\int M_x(M_o/EJ+\theta)dx$	$\int X M_x M_x/EJdx$
AB b	0	$-1/2Fx-1/2qx^2$	0	0	0	0	0+0	0
BA b	0	$Fb-3/2Fx+1/2qx^2$	0	0	0	0	0	0
BC $\sqrt{2}b$	0	$-Fb+\sqrt{2}/2Fx$	0	0	0	0	0	0
BD b	0	0	0	0	0	0	0+0	0
DB b	0	0	0	0	0	0	0	0
DC b	0	$-2Fx$	0	0	0	0	0+0	0
CD b	0	$2Fb-2Fx$	0	0	0	0	0	0
CE b	0	$-Fb+Fx$	0	0	0	0	0+0	0
EC b	0	Fx	0	0	0	0	0	0
FG b	$-1/2x/b$	$-3/2Fx$	$-Fb/EJ$	$3/4Fx^2/b$	$1/2Fx/EJ$	$1/4x^2/b^2$	$(1/4+1/4)Fb^2/EJ$	$1/12Xb/EJ$
GF b	$1/2-1/2x/b$	$3/2Fb-3/2Fx$	Fb/EJ	$3/4Fb-3/2Fx+3/4Fx^2/b$	$1/2Fb/EJ-1/2Fx/EJ$	$1/4-1/2x/b+1/4x^2/b^2$		
GD b	$-1+x/b$	$-3/2Fx$	0	$3/2Fx-3/2Fx^2/b$	0	$1-2x/b+x^2/b^2$	$(1/4+0)Fb^2/EJ$	$1/3Xb/EJ$
DG b	x/b	$3/2Fb-3/2Fx$	0	$3/2Fx-3/2Fx^2/b$	0	x^2/b^2		
DH b	0	$-3/2Fb+2Fx-1/2qx^2$	0	0	0	0	0+0	0
HD b	0	$Fx+1/2qx^2$	0	0	0	0	0	0
GA b	$1/2-1/2x/b$	$-1/2Fb+1/2Fx$	0	$-1/4Fb+1/2Fx-1/4Fx^2/b$	0	$1/4-1/2x/b+1/4x^2/b^2$	$(-1/12+0)Fb^2/EJ$	$1/12Xb/EJ$
AG b	$-1/2x/b$	$1/2Fx$	0	$-1/4Fx^2/b$	0	$1/4x^2/b^2$		
	totali						$2/3Fb^2/EJ$	$1/2Xb/EJ$
	iperstatica $X=W_{GD}$						$-4/3Fb$	

Sviluppi di calcolo iperstatica

$$L_{FG}^{xx} = \int_0^b (1/4 x^2/b^2) 1/EJ dx = [1/12 x^3/b^2]_0^b 1/EJ$$

$$= (1/12 b) 1/EJ = 1/12 b/EJ$$

$$L_{GF}^{xx} = \int_0^b (1/4 - 1/2 x/b + 1/4 x^2/b^2) 1/EJ dx = [1/4 x - 1/4 x^2/b + 1/12 x^3/b^2]_0^b 1/EJ$$

$$= (1/4 b - 1/4 b + 1/12 b) 1/EJ = 1/12 b/EJ$$

$$L_{GD}^{xx} = \int_0^b (1 - 2 x/b + x^2/b^2) 1/EJ dx = [x - x^2/b + 1/3 x^3/b^2]_0^b 1/EJ$$

$$= (b - b + 1/3 b) 1/EJ = 1/3 b/EJ$$

$$L_{DG}^{xx} = \int_0^b (x^2/b^2) 1/EJ dx = [1/3 x^3/b^2]_0^b 1/EJ$$

$$= (1/3 b) 1/EJ = 1/3 b/EJ$$

$$L_{GA}^{xx} = \int_0^b (1/4 - 1/2 x/b + 1/4 x^2/b^2) 1/EJ dx = [1/4 x - 1/4 x^2/b + 1/12 x^3/b^2]_0^b 1/EJ$$

$$= (1/4 b - 1/4 b + 1/12 b) 1/EJ = 1/12 b/EJ$$

$$L_{AG}^{xx} = \int_0^b (1/4 x^2/b^2) 1/EJ dx = [1/12 x^3/b^2]_0^b 1/EJ$$

$$= (1/12 b) 1/EJ = 1/12 b/EJ$$

$$L_{FG}^{xo} = \int_0^b (3/4 x^2/b^2) Fb 1/EJ dx + \int_0^b (1/2 x/b) \theta dx = [1/4 x^3/b^2]_0^b Fb 1/EJ + [1/4 x^2/b]_0^b \theta$$

$$= (1/4 b) Fb 1/EJ + (1/4 b) \theta = 1/2 Fb^2/EJ$$

$$L_{GF}^{xo} = \int_0^b (3/4 - 3/2 x/b + 3/4 x^2/b^2) Fb 1/EJ dx + \int_0^b (-1/2 + 1/2 x/b) \theta dx$$

$$= [3/4 x - 3/4 x^2/b + 1/4 x^3/b^2]_0^b Fb 1/EJ + [-1/2 x + 1/4 x^2/b]_0^b \theta$$

$$= (3/4 b - 3/4 b + 1/4 b) Fb 1/EJ + (-1/2 b + 1/4 b) \theta = 1/2 Fb^2/EJ$$

$$L_{GD}^{xo} = \int_0^b (3/2 x/b - 3/2 x^2/b^2) Fb 1/EJ dx = [3/4 x^2/b - 1/2 x^3/b^2]_0^b Fb 1/EJ$$

$$= (3/4 b - 1/2 b) Fb 1/EJ = 1/4 Fb^2/EJ$$

$$L_{DG}^{xo} = \int_0^b (3/2 x/b - 3/2 x^2/b^2) Fb 1/EJ dx = [3/4 x^2/b - 1/2 x^3/b^2]_0^b Fb 1/EJ$$

$$= (3/4 b - 1/2 b) Fb 1/EJ = 1/4 Fb^2/EJ$$

$$L_{GA}^{xo} = \int_0^b (-1/4 + 1/2 x/b - 1/4 x^2/b^2) Fb 1/EJ dx = [-1/4 x + 1/4 x^2/b - 1/12 x^3/b^2]_0^b Fb 1/EJ$$

$$= (-1/4 b + 1/4 b - 1/12 b) Fb 1/EJ = -1/12 Fb^2/EJ$$

$$L_{AG}^{xo} = \int_0^b (-1/4 x^2/b^2) Fb 1/EJ dx = [-1/12 x^3/b^2]_0^b Fb 1/EJ$$

$$= (-1/12 b) Fb 1/EJ = -1/12 Fb^2/EJ$$

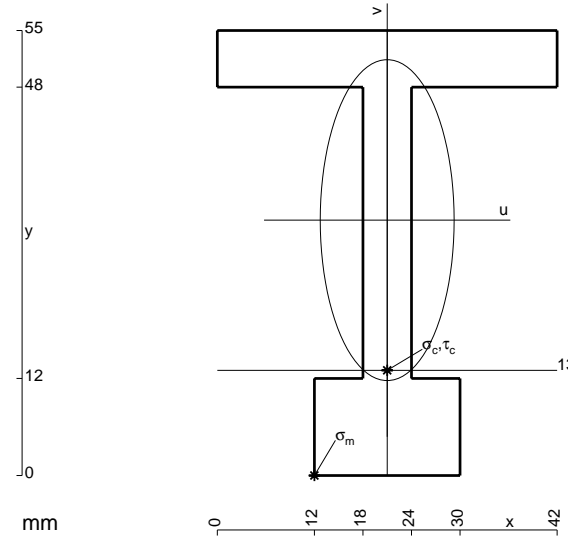

- A = 726. mm²
- J_u = 285657. mm⁴
- J_v = 49698. mm⁴
- y_g = 31.57 mm
- T_y = -2260. N
- M_x = -1988800. Nmm
- x_m = 12. mm
- u_m = -9. mm
- v_m = -31.57 mm
- σ_m = -Mv/J_u = -219.8 N/mm²
- x_c = 21. mm
- y_c = 13. mm
- v_c = -18.57 mm
- σ_c = -Mv/J_u = -129.3 N/mm²
- τ_c = 7.432 N/mm²
- σ_o = √σ²+3τ² = 129.9 N/mm²
- S = 5637. mm³

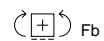
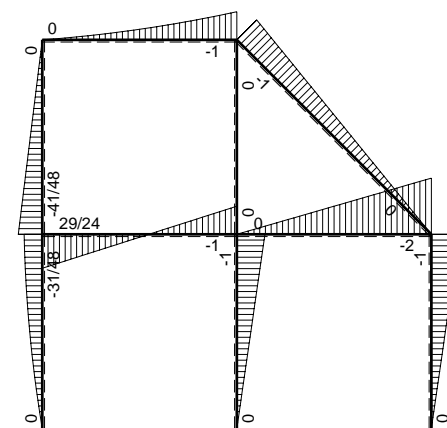
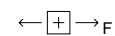
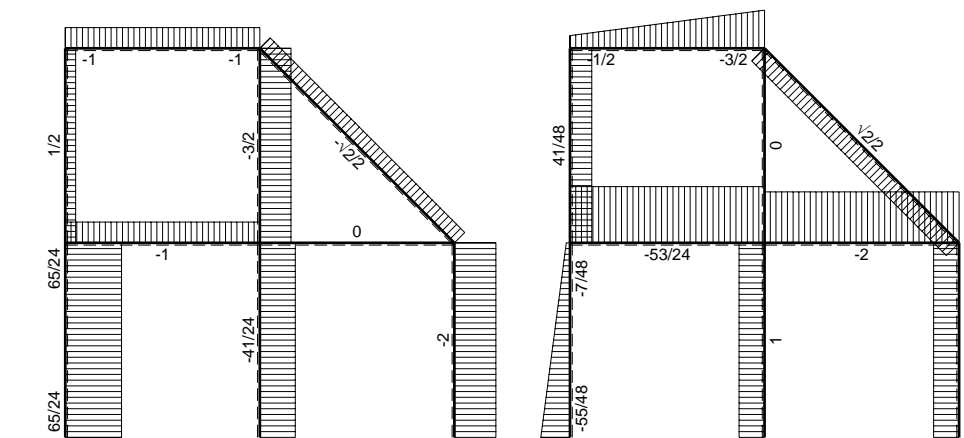
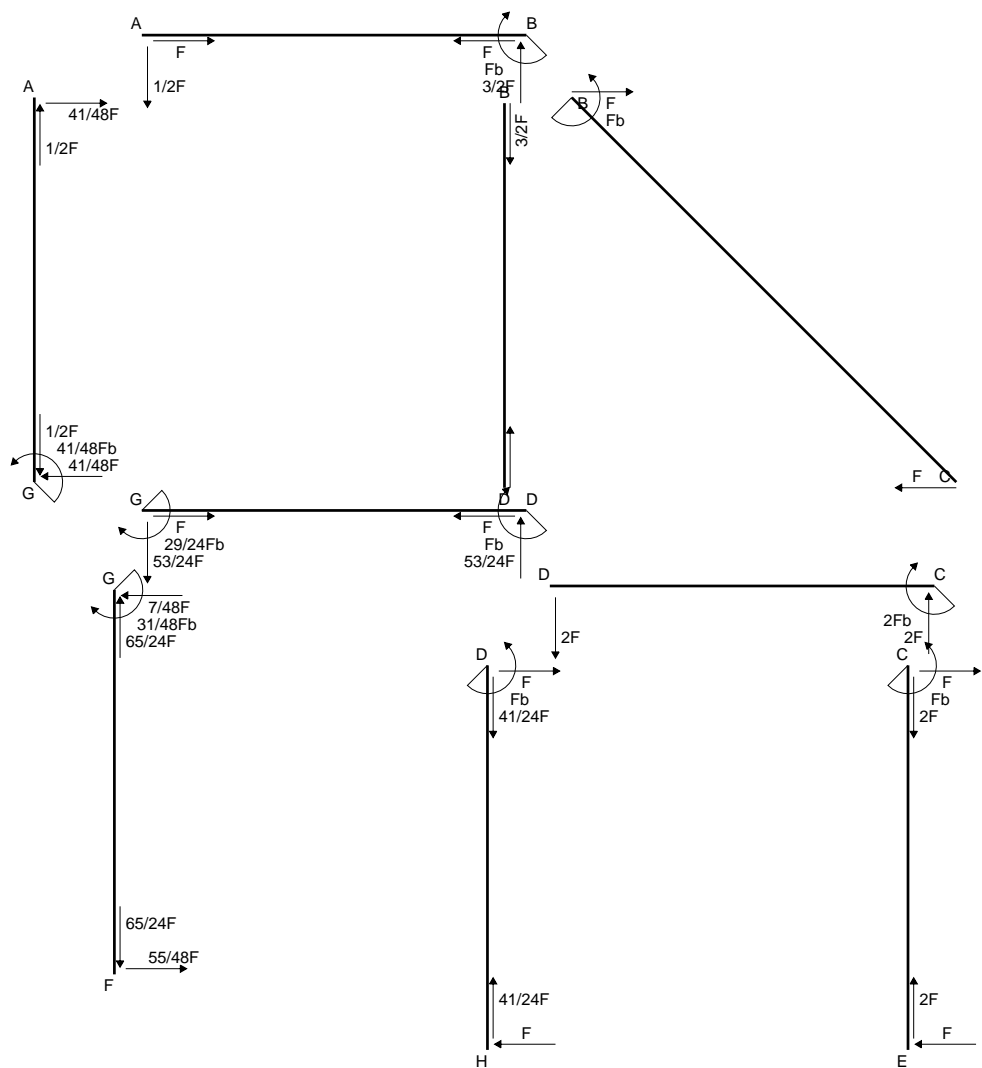

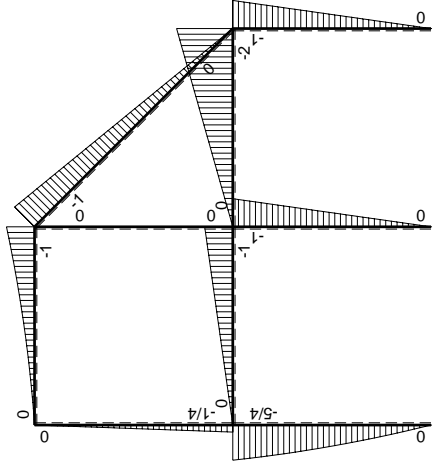
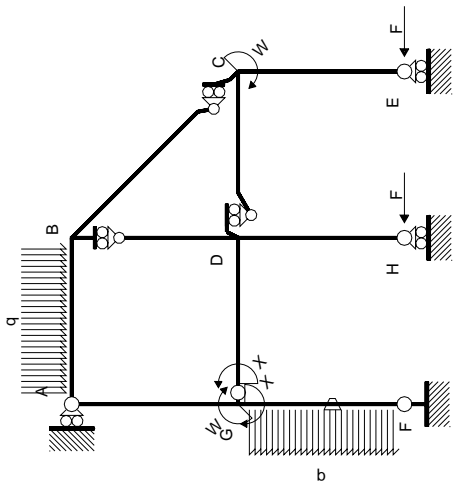

Schema di calcolo iperstatico

M_0 flessione da carichi assegnati

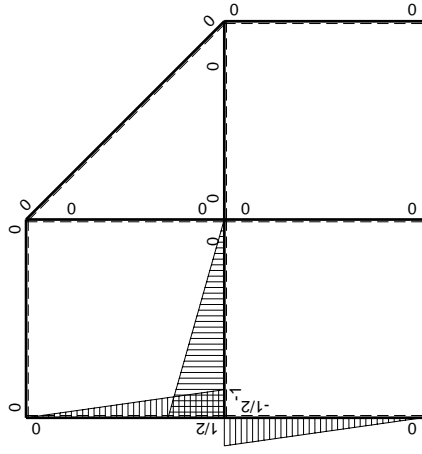

M_x flessione da iperstatica $X=1$

Quadro contributi PLV per iperstatica $X=W_{GD}$

→	$M_x(x)$	$M_o(x)$	θ	$M_x M_o$	$M_x \theta$	$M_x M_x$	$\int M_x(M_o/EJ+\theta)dx$	$\int X M_x M_x/EJdx$
AB b	0	$-1/2Fx-1/2qx^2$	0	0	0	0	0+0	0
BA b	0	$Fb-3/2Fx+1/2qx^2$	0	0	0	0	0	0
BC $\sqrt{2}b$	0	$-Fb+\sqrt{2}/2Fx$	0	0	0	0	0	0
BD b	0	0	0	0	0	0	0+0	0
DB b	0	0	0	0	0	0	0	0
DC b	0	$-2Fx$	0	0	0	0	0+0	0
CD b	0	$2Fb-2Fx$	0	0	0	0	0	0
CE b	0	$-Fb+Fx$	0	0	0	0	0+0	0
EC b	0	Fx	0	0	0	0	0	0
FG b	$-1/2x/b$	$-7/4Fx+1/2qx^2$	$-Fb/EJ$	$7/8Fx^2/b-1/4qx^3/b$	$1/2Fx/EJ$	$1/4x^2/b^2$	$(11/48+1/4)Fb^2/EJ$	$1/12Xb/EJ$
GF b	$1/2-1/2x/b$	$5/4Fb-3/4Fx-1/2qx^2$	Fb/EJ	$5/8Fb-Fx+1/8Fx^2/b+1/4qx^3/b$	$1/2Fb/EJ-1/2Fx/EJ$	$1/4-1/2x/b+1/4x^2/b^2$		
GD b	$-1+x/b$	$-Fx$	0	$Fx-Fx^2/b$	0	$1-2x/b+x^2/b^2$	$(1/6+0)Fb^2/EJ$	$1/3Xb/EJ$
DG b	x/b	$Fb-Fx$	0	$Fx-Fx^2/b$	0	x^2/b^2		
DH b	0	$-Fb+Fx$	0	0	0	0	0+0	0
HD b	0	Fx	0	0	0	0		
GA b	$1/2-1/2x/b$	$-1/4Fb+1/4Fx$	0	$-1/8Fb+1/4Fx-1/8Fx^2/b$	0	$1/4-1/2x/b+1/4x^2/b^2$	$(-1/24+0)Fb^2/EJ$	$1/12Xb/EJ$
AG b	$-1/2x/b$	$1/4Fx$	0	$-1/8Fx^2/b$	0	$1/4x^2/b^2$		
	totali						$29/48Fb^2/EJ$	$1/2Xb/EJ$
	iperstatica $X=W_{GD}$						$-29/24Fb$	

Sviluppi di calcolo iperstatica

$$L_{FG}^{xx} = \int_0^b (1/4 x^2/b^2) 1/EJ dx = [1/12 x^3/b^2]_0^b 1/EJ$$

$$= (1/12 b) 1/EJ = 1/12 b/EJ$$

$$L_{GF}^{xx} = \int_0^b (1/4 - 1/2 x/b + 1/4 x^2/b^2) 1/EJ dx = [1/4 x - 1/4 x^2/b + 1/12 x^3/b^2]_0^b 1/EJ$$

$$= (1/4 b - 1/4 b + 1/12 b) 1/EJ = 1/12 b/EJ$$

$$L_{GD}^{xx} = \int_0^b (1 - 2 x/b + x^2/b^2) 1/EJ dx = [x - x^2/b + 1/3 x^3/b^2]_0^b 1/EJ$$

$$= (b - b + 1/3 b) 1/EJ = 1/3 b/EJ$$

$$L_{DG}^{xx} = \int_0^b (x^2/b^2) 1/EJ dx = [1/3 x^3/b^2]_0^b 1/EJ$$

$$= (1/3 b) 1/EJ = 1/3 b/EJ$$

$$L_{GA}^{xx} = \int_0^b (1/4 - 1/2 x/b + 1/4 x^2/b^2) 1/EJ dx = [1/4 x - 1/4 x^2/b + 1/12 x^3/b^2]_0^b 1/EJ$$

$$= (1/4 b - 1/4 b + 1/12 b) 1/EJ = 1/12 b/EJ$$

$$L_{AG}^{xx} = \int_0^b (1/4 x^2/b^2) 1/EJ dx = [1/12 x^3/b^2]_0^b 1/EJ$$

$$= (1/12 b) 1/EJ = 1/12 b/EJ$$

$$L_{FG}^{xo} = \int_0^b (7/8 x^2/b^2 - 1/4 x^3/b^3) Fb 1/EJ dx + \int_0^b (1/2 x/b) \theta dx$$

$$= [7/24 x^3/b^2 - 1/16 x^4/b^3]_0^b Fb 1/EJ + [1/4 x^2/b]_0^b \theta$$

$$= (7/24 b - 1/16 b) Fb 1/EJ + (1/4 b) \theta = 23/48 Fb^2/EJ$$

$$L_{GF}^{xo} = \int_0^b (5/8 - x/b + 1/8 x^2/b^2 + 1/4 x^3/b^3) Fb 1/EJ dx + \int_0^b (-1/2 + 1/2 x/b) \theta dx$$

$$= [5/8 x - 1/2 x^2/b + 1/24 x^3/b^2 + 1/16 x^4/b^3]_0^b Fb 1/EJ + [-1/2 x + 1/4 x^2/b]_0^b \theta$$

$$= (5/8 b - 1/2 b + 1/24 b + 1/16 b) Fb 1/EJ + (-1/2 b + 1/4 b) \theta = 23/48 Fb^2/EJ$$

$$L_{GD}^{xo} = \int_0^b (x/b - x^2/b^2) Fb 1/EJ dx = [1/2 x^2/b - 1/3 x^3/b^2]_0^b Fb 1/EJ$$

$$= (1/2 b - 1/3 b) Fb 1/EJ = 1/6 Fb^2/EJ$$

$$L_{DG}^{xo} = \int_0^b (x/b - x^2/b^2) Fb 1/EJ dx = [1/2 x^2/b - 1/3 x^3/b^2]_0^b Fb 1/EJ$$

$$= (1/2 b - 1/3 b) Fb 1/EJ = 1/6 Fb^2/EJ$$

$$L_{GA}^{xo} = \int_0^b (-1/8 + 1/4 x/b - 1/8 x^2/b^2) Fb 1/EJ dx = [-1/8 x + 1/8 x^2/b - 1/24 x^3/b^2]_0^b Fb 1/EJ$$

$$= (-1/8 b + 1/8 b - 1/24 b) Fb 1/EJ = -1/24 Fb^2/EJ$$

$$L_{AG}^{xo} = \int_0^b (-1/8 x^2/b^2) Fb 1/EJ dx = [-1/24 x^3/b^2]_0^b Fb 1/EJ$$

$$= (-1/24 b) Fb 1/EJ = -1/24 Fb^2/EJ$$

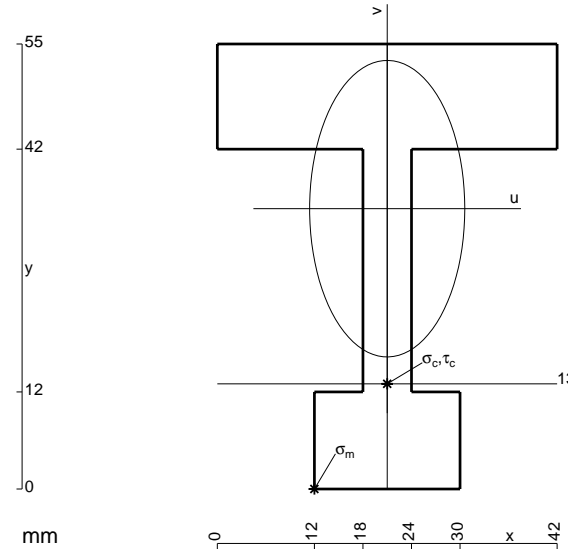

- A = 942. mm²
- J_u = 316348. mm⁴
- J_v = 86634. mm⁴
- y_g = 34.65 mm
- T_y = -2240. N
- M_x = -2083200. Nmm
- x_m = 12. mm
- u_m = -9. mm
- v_m = -34.65 mm
- σ_m = -Mv/J_u = -228.2 N/mm²
- x_c = 21. mm
- y_c = 13. mm
- v_c = -21.65 mm
- σ_c = -Mv/J_u = -142.5 N/mm²
- τ_c = 7.459 N/mm²
- σ_q = √σ²+3τ² = 143.1 N/mm²
- S = 6321. mm³

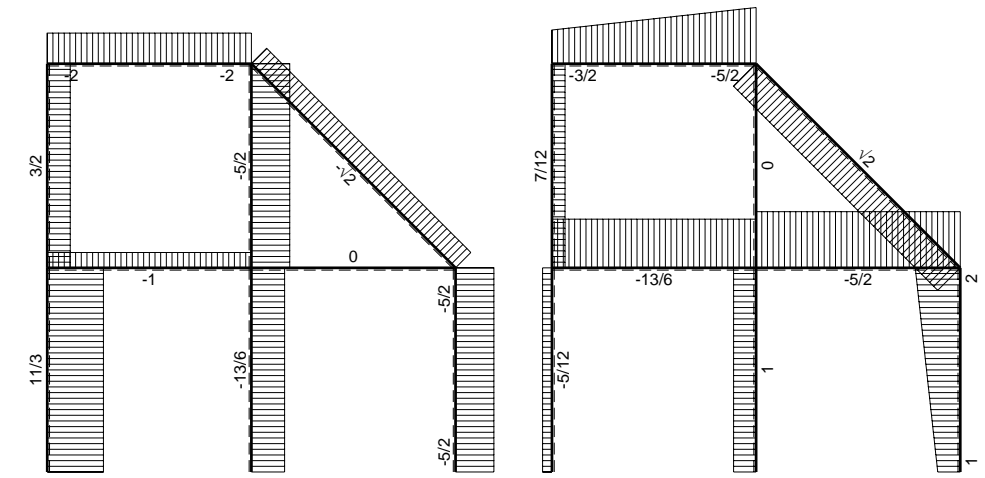
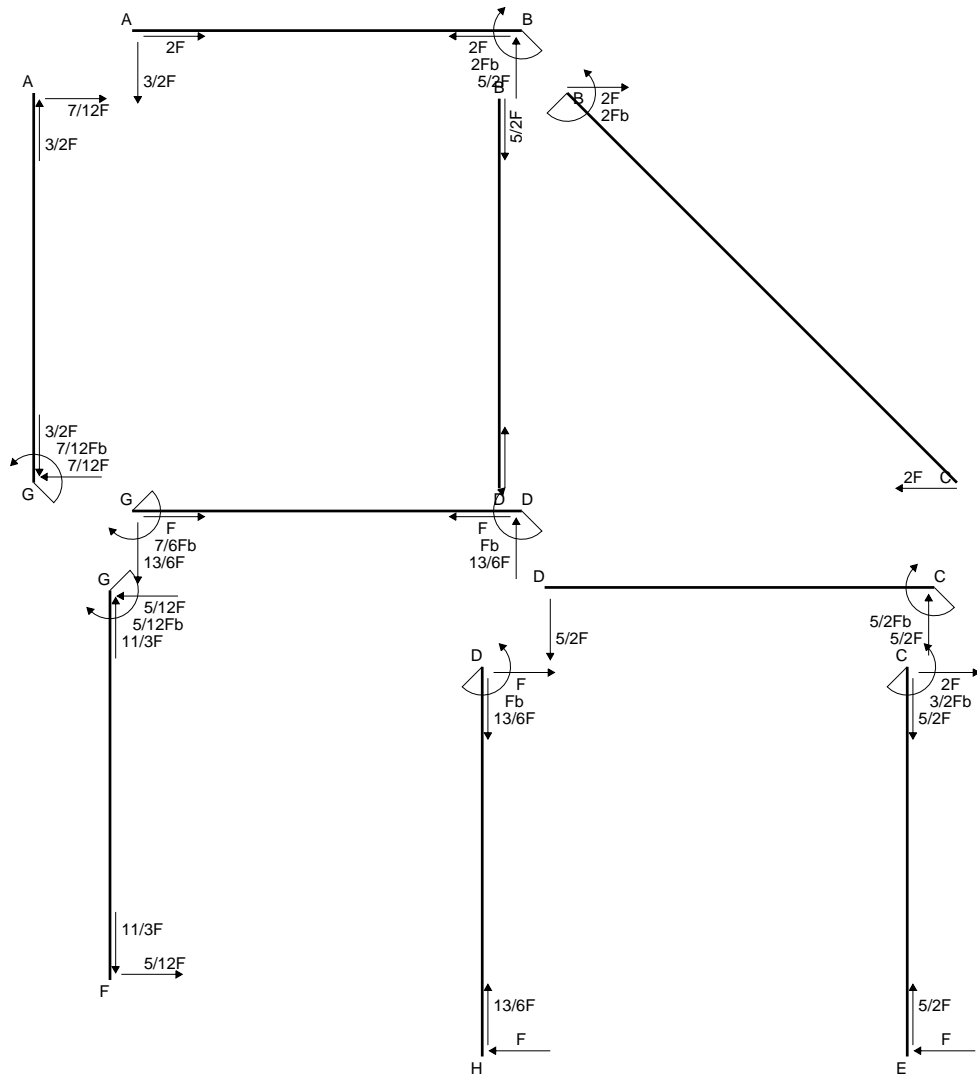

← ⊕ → F

↑ ⊕ ↓ F

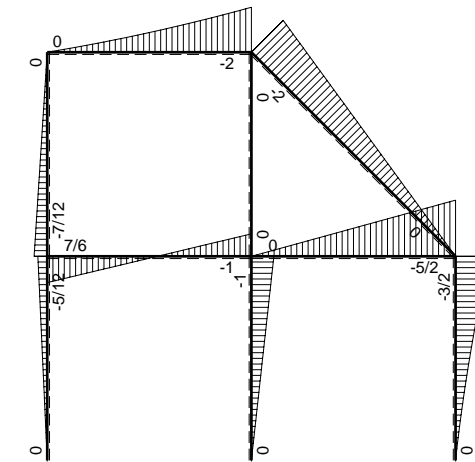

⊕ ⊖ F_b

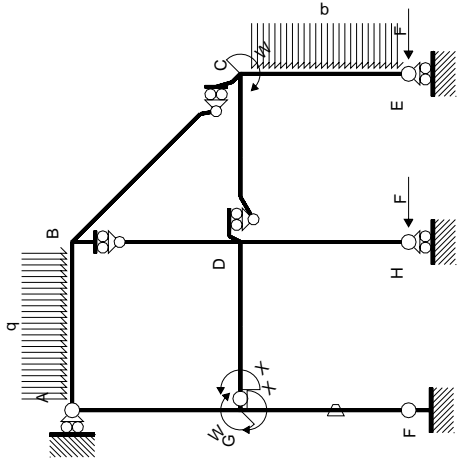

Schema di calcolo iperstatico

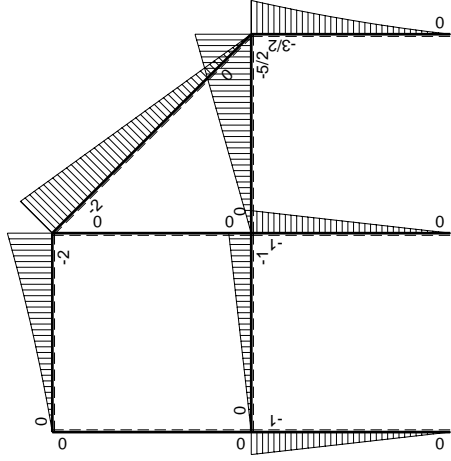

M_0 flessione da carichi assegnati

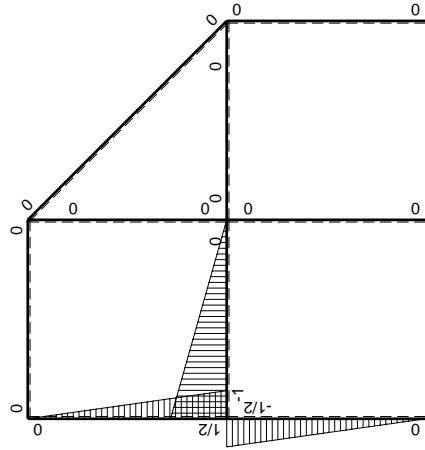

M_x flessione da iperstatica $X=1$

Quadro contributi PLV per iperstatica $X=W_{GD}$

→	$M_x(x)$	$M_o(x)$	θ	$M_x M_o$	$M_x \theta$	$M_x M_x$	$\int M_x(M_o/EJ+\theta)dx$	$\int x M_x M_x/EJ dx$
AB b	0	$-3/2Fx-1/2qx^2$	0	0	0	0	0+0	0
BA b	0	$2Fb-5/2Fx+1/2qx^2$	0	0	0	0	0	0
BC $\sqrt{2}b$	0	$-2Fb+\sqrt{2}Fx$	0	0	0	0	0	0
BD b	0	0	0	0	0	0	0+0	0
DB b	0	0	0	0	0	0	0	0
DC b	0	$-5/2Fx$	0	0	0	0	0+0	0
CD b	0	$5/2Fb-5/2Fx$	0	0	0	0	0	0
CE b	0	$-3/2Fb+2Fx-1/2qx^2$	0	0	0	0	0+0	0
EC b	0	$Fx+1/2qx^2$	0	0	0	0	0	0
FG b	$-1/2x/b$	$-Fx$	$-Fb/EJ$	$1/2Fx^2/b$	$1/2Fx/EJ$	$1/4x^2/b^2$	$(1/6+1/4)Fb^2/EJ$	$1/12Xb/EJ$
GF b	$1/2-1/2x/b$	$Fb-Fx$	Fb/EJ	$1/2Fb-Fx+1/2Fx^2/b$	$1/2Fb/EJ-1/2Fx/EJ$	$1/4-1/2x/b+1/4x^2/b^2$		
GD b	$-1+x/b$	$-Fx$	0	$Fx-Fx^2/b$	0	$1-2x/b+x^2/b^2$	$(1/6+0)Fb^2/EJ$	$1/3Xb/EJ$
DG b	x/b	$Fb-Fx$	0	$Fx-Fx^2/b$	0	x^2/b^2		
DH b	0	$-Fb+Fx$	0	0	0	0	0+0	0
HD b	0	Fx	0	0	0	0	0	0
GA b	$1/2-1/2x/b$	0	0	0	0	$1/4-1/2x/b+1/4x^2/b^2$	0+0	$1/12Xb/EJ$
AG b	$-1/2x/b$	0	0	0	0	$1/4x^2/b^2$		
	totali						$7/12Fb^2/EJ$	$1/2Xb/EJ$
	iperstatica $X=W_{GD}$						$-7/6Fb$	

Sviluppi di calcolo iperstatica

$$L_{FG}^{xx} = \int_0^b (1/4 x^2/b^2) 1/EJ dx = [1/12 x^3/b^2]_0^b 1/EJ$$

$$= (1/12 b) 1/EJ = 1/12 b/EJ$$

$$L_{GF}^{xx} = \int_0^b (1/4 - 1/2 x/b + 1/4 x^2/b^2) 1/EJ dx = [1/4 x - 1/4 x^2/b + 1/12 x^3/b^2]_0^b 1/EJ$$

$$= (1/4 b - 1/4 b + 1/12 b) 1/EJ = 1/12 b/EJ$$

$$L_{GD}^{xx} = \int_0^b (1 - 2 x/b + x^2/b^2) 1/EJ dx = [x - x^2/b + 1/3 x^3/b^2]_0^b 1/EJ$$

$$= (b - b + 1/3 b) 1/EJ = 1/3 b/EJ$$

$$L_{DG}^{xx} = \int_0^b (x^2/b^2) 1/EJ dx = [1/3 x^3/b^2]_0^b 1/EJ$$

$$= (1/3 b) 1/EJ = 1/3 b/EJ$$

$$L_{GA}^{xx} = \int_0^b (1/4 - 1/2 x/b + 1/4 x^2/b^2) 1/EJ dx = [1/4 x - 1/4 x^2/b + 1/12 x^3/b^2]_0^b 1/EJ$$

$$= (1/4 b - 1/4 b + 1/12 b) 1/EJ = 1/12 b/EJ$$

$$L_{AG}^{xx} = \int_0^b (1/4 x^2/b^2) 1/EJ dx = [1/12 x^3/b^2]_0^b 1/EJ$$

$$= (1/12 b) 1/EJ = 1/12 b/EJ$$

$$L_{FG}^{xo} = \int_0^b (1/2 x^2/b^2) Fb 1/EJ dx + \int_0^b (1/2 x/b) \theta dx = [1/6 x^3/b^2]_0^b Fb 1/EJ + [1/4 x^2/b]_0^b \theta$$

$$= (1/6 b) Fb 1/EJ + (1/4 b) \theta = 5/12 Fb^2/EJ$$

$$L_{GF}^{xo} = \int_0^b (1/2 - x/b + 1/2 x^2/b^2) Fb 1/EJ dx + \int_0^b (-1/2 + 1/2 x/b) \theta dx$$

$$= [1/2 x - 1/2 x^2/b + 1/6 x^3/b^2]_0^b Fb 1/EJ + [-1/2 x + 1/4 x^2/b]_0^b \theta$$

$$= (1/2 b - 1/2 b + 1/6 b) Fb 1/EJ + (-1/2 b + 1/4 b) \theta = 5/12 Fb^2/EJ$$

$$L_{GD}^{xo} = \int_0^b (x/b - x^2/b^2) Fb 1/EJ dx = [1/2 x^2/b - 1/3 x^3/b^2]_0^b Fb 1/EJ$$

$$= (1/2 b - 1/3 b) Fb 1/EJ = 1/6 Fb^2/EJ$$

$$L_{DG}^{xo} = \int_0^b (x/b - x^2/b^2) Fb 1/EJ dx = [1/2 x^2/b - 1/3 x^3/b^2]_0^b Fb 1/EJ$$

$$= (1/2 b - 1/3 b) Fb 1/EJ = 1/6 Fb^2/EJ$$

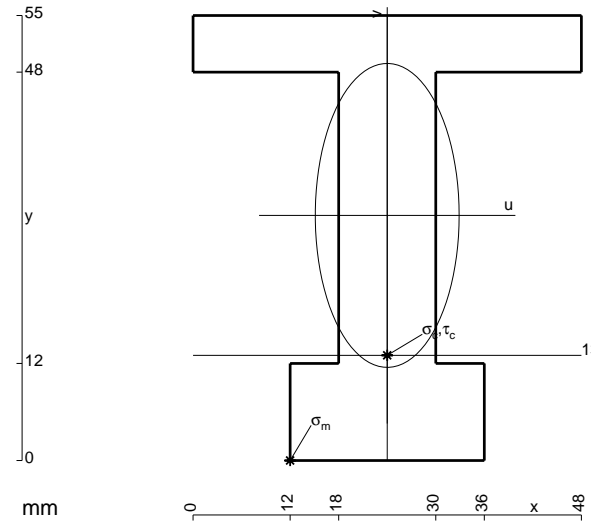

- A = 1056. mm²
- J_u = 372596. mm⁴
- J_v = 83520. mm⁴
- y_g = 30.3 mm
- T_y = -3000. N
- M_x = -2940000. Nmm
- x_m = 12. mm
- u_m = -12. mm
- v_m = -30.3 mm
- σ_m = -Mv/J_u = -239. N/mm²
- x_c = 24. mm
- y_c = 13. mm
- v_c = -17.3 mm
- σ_c = -Mv/J_u = -136.5 N/mm²
- τ_c = 4.838 N/mm²
- σ_o = √σ²+3τ² = 136.7 N/mm²
- S = 7211. mm³

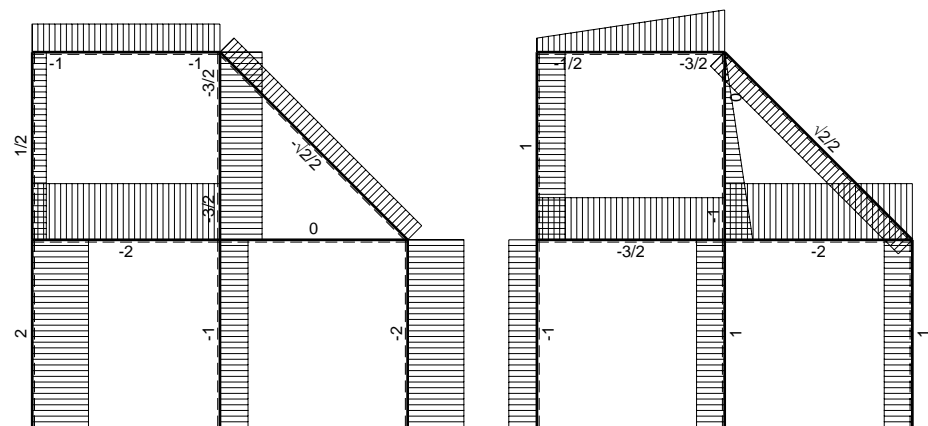
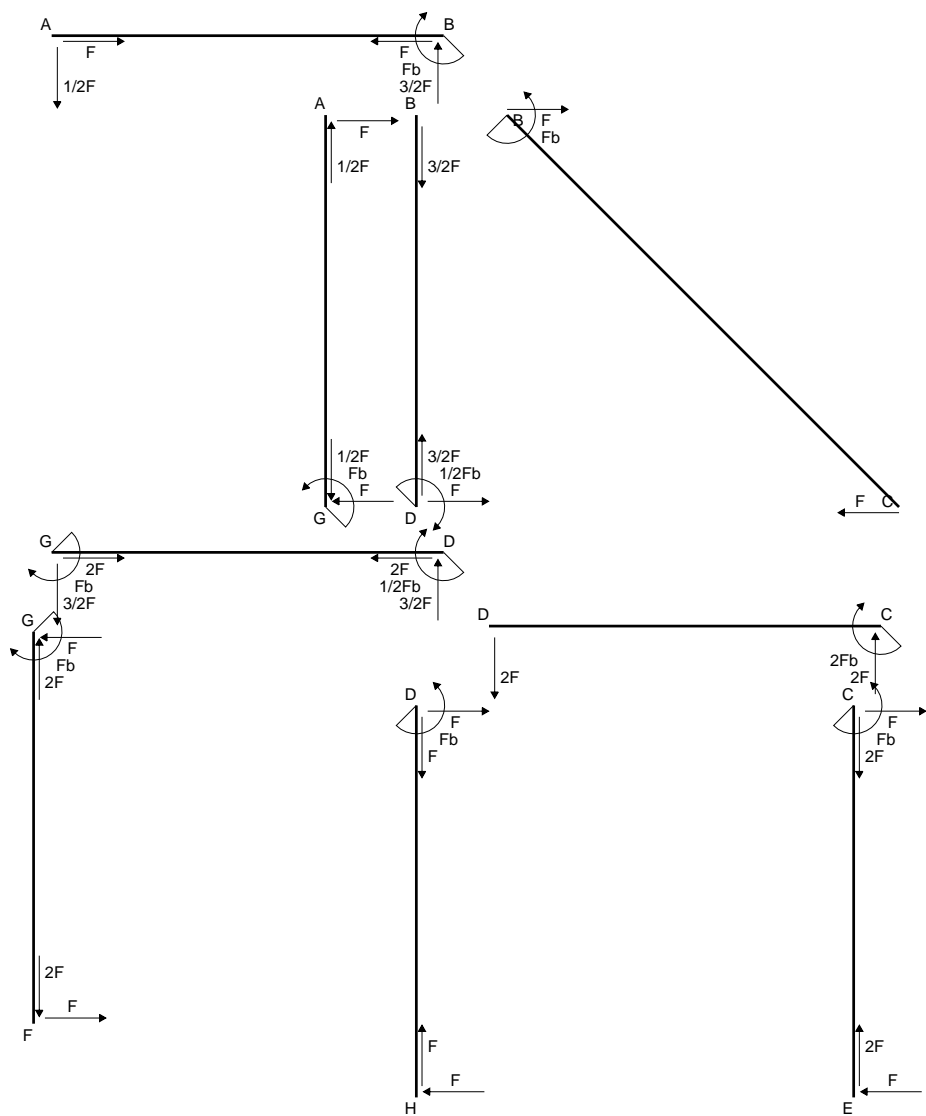

← ⊕ → F

↑ ⊕ ↓ F

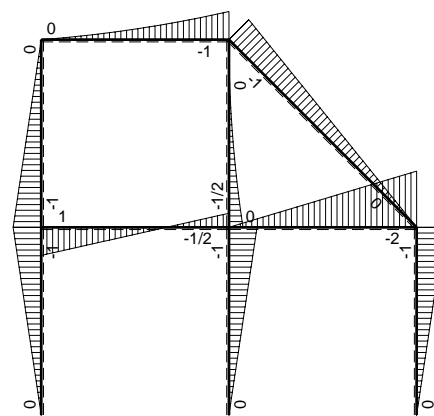

⊕ ⊖ F_b

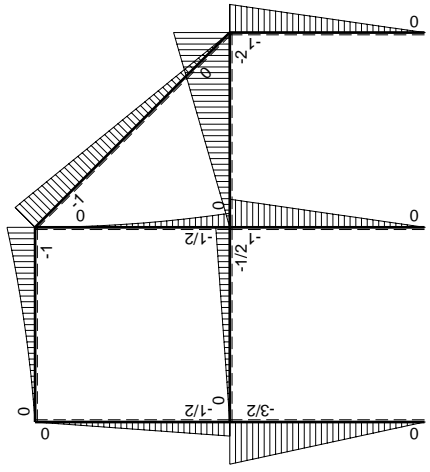
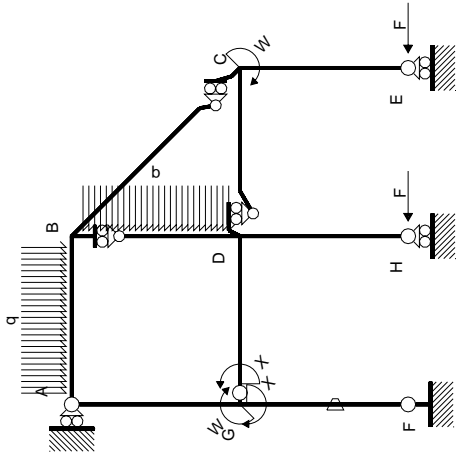

Schema di calcolo iperstatico

M_0 flessione da carichi assegnati

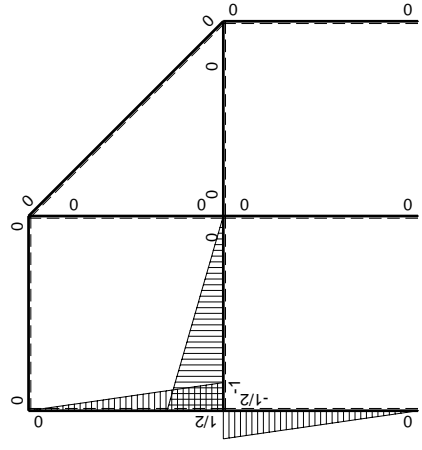

M_x flessione da iperstatica $X=1$

Quadro contributi PLV per iperstatica $X=W_{GD}$

→	$M_x(x)$	$M_o(x)$	θ	$M_x M_o$	$M_x \theta$	$M_x M_x$	$\int M_x(M_o/EJ+\theta)dx$	$\int X M_x M_x/EJ dx$
AB b	0	$-1/2Fx-1/2qx^2$	0	0	0	0	0+0	0
BA b	0	$Fb-3/2Fx+1/2qx^2$	0	0	0	0	0	0
BC $\sqrt{2}b$	0	$-Fb+\sqrt{2}/2Fx$	0	0	0	0	0	0
BD b	0	$-1/2qx^2$	0	0	0	0	0+0	0
DB b	0	$1/2Fb-Fx+1/2qx^2$	0	0	0	0	0	0
DC b	0	$-2Fx$	0	0	0	0	0+0	0
CD b	0	$2Fb-2Fx$	0	0	0	0	0	0
CE b	0	$-Fb+Fx$	0	0	0	0	0+0	0
EC b	0	Fx	0	0	0	0	0	0
FG b	$-1/2x/b$	$-3/2Fx$	$-Fb/EJ$	$3/4Fx^2/b$	$1/2Fx/EJ$	$1/4x^2/b^2$	$(1/4+1/4)Fb^2/EJ$	$1/12Xb/EJ$
GF b	$1/2-1/2x/b$	$3/2Fb-3/2Fx$	Fb/EJ	$3/4Fb-3/2Fx+3/4Fx^2/b$	$1/2Fb/EJ-1/2Fx/EJ$	$1/4-1/2x/b+1/4x^2/b^2$		
GD b	$-1+x/b$	$-1/2Fx$	0	$1/2Fx-1/2Fx^2/b$	0	$1-2x/b+x^2/b^2$	$(1/12+0)Fb^2/EJ$	$1/3Xb/EJ$
DG b	x/b	$1/2Fb-1/2Fx$	0	$1/2Fx-1/2Fx^2/b$	0	x^2/b^2		
DH b	0	$-Fb+Fx$	0	0	0	0	0+0	0
HD b	0	Fx	0	0	0	0	0	0
GA b	$1/2-1/2x/b$	$-1/2Fb+1/2Fx$	0	$-1/4Fb+1/2Fx-1/4Fx^2/b$	0	$1/4-1/2x/b+1/4x^2/b^2$	$(-1/12+0)Fb^2/EJ$	$1/12Xb/EJ$
AG b	$-1/2x/b$	$1/2Fx$	0	$-1/4Fx^2/b$	0	$1/4x^2/b^2$		
	totali						$1/2Fb^2/EJ$	$1/2Xb/EJ$
	iperstatica $X=W_{GD}$						$-Fb$	

Sviluppi di calcolo iperstatica

$$L_{FG}^{xx} = \int_0^b (1/4 x^2/b^2) 1/EJ dx = [1/12 x^3/b^2]_0^b 1/EJ$$

$$= (1/12 b) 1/EJ = 1/12 b/EJ$$

$$L_{GF}^{xx} = \int_0^b (1/4 - 1/2 x/b + 1/4 x^2/b^2) 1/EJ dx = [1/4 x - 1/4 x^2/b + 1/12 x^3/b^2]_0^b 1/EJ$$

$$= (1/4 b - 1/4 b + 1/12 b) 1/EJ = 1/12 b/EJ$$

$$L_{GD}^{xx} = \int_0^b (1 - 2 x/b + x^2/b^2) 1/EJ dx = [x - x^2/b + 1/3 x^3/b^2]_0^b 1/EJ$$

$$= (b - b + 1/3 b) 1/EJ = 1/3 b/EJ$$

$$L_{DG}^{xx} = \int_0^b (x^2/b^2) 1/EJ dx = [1/3 x^3/b^2]_0^b 1/EJ$$

$$= (1/3 b) 1/EJ = 1/3 b/EJ$$

$$L_{GA}^{xx} = \int_0^b (1/4 - 1/2 x/b + 1/4 x^2/b^2) 1/EJ dx = [1/4 x - 1/4 x^2/b + 1/12 x^3/b^2]_0^b 1/EJ$$

$$= (1/4 b - 1/4 b + 1/12 b) 1/EJ = 1/12 b/EJ$$

$$L_{AG}^{xx} = \int_0^b (1/4 x^2/b^2) 1/EJ dx = [1/12 x^3/b^2]_0^b 1/EJ$$

$$= (1/12 b) 1/EJ = 1/12 b/EJ$$

$$L_{FG}^{xo} = \int_0^b (3/4 x^2/b^2) Fb 1/EJ dx + \int_0^b (1/2 x/b) \theta dx = [1/4 x^3/b^2]_0^b Fb 1/EJ + [1/4 x^2/b]_0^b \theta$$

$$= (1/4 b) Fb 1/EJ + (1/4 b) \theta = 1/2 Fb^2/EJ$$

$$L_{GF}^{xo} = \int_0^b (3/4 - 3/2 x/b + 3/4 x^2/b^2) Fb 1/EJ dx + \int_0^b (-1/2 + 1/2 x/b) \theta dx$$

$$= [3/4 x - 3/4 x^2/b + 1/4 x^3/b^2]_0^b Fb 1/EJ + [-1/2 x + 1/4 x^2/b]_0^b \theta$$

$$= (3/4 b - 3/4 b + 1/4 b) Fb 1/EJ + (-1/2 b + 1/4 b) \theta = 1/2 Fb^2/EJ$$

$$L_{GD}^{xo} = \int_0^b (1/2 x/b - 1/2 x^2/b^2) Fb 1/EJ dx = [1/4 x^2/b - 1/6 x^3/b^2]_0^b Fb 1/EJ$$

$$= (1/4 b - 1/6 b) Fb 1/EJ = 1/12 Fb^2/EJ$$

$$L_{DG}^{xo} = \int_0^b (1/2 x/b - 1/2 x^2/b^2) Fb 1/EJ dx = [1/4 x^2/b - 1/6 x^3/b^2]_0^b Fb 1/EJ$$

$$= (1/4 b - 1/6 b) Fb 1/EJ = 1/12 Fb^2/EJ$$

$$L_{GA}^{xo} = \int_0^b (-1/4 + 1/2 x/b - 1/4 x^2/b^2) Fb 1/EJ dx = [-1/4 x + 1/4 x^2/b - 1/12 x^3/b^2]_0^b Fb 1/EJ$$

$$= (-1/4 b + 1/4 b - 1/12 b) Fb 1/EJ = -1/12 Fb^2/EJ$$

$$L_{AG}^{xo} = \int_0^b (-1/4 x^2/b^2) Fb 1/EJ dx = [-1/12 x^3/b^2]_0^b Fb 1/EJ$$

$$= (-1/12 b) Fb 1/EJ = -1/12 Fb^2/EJ$$

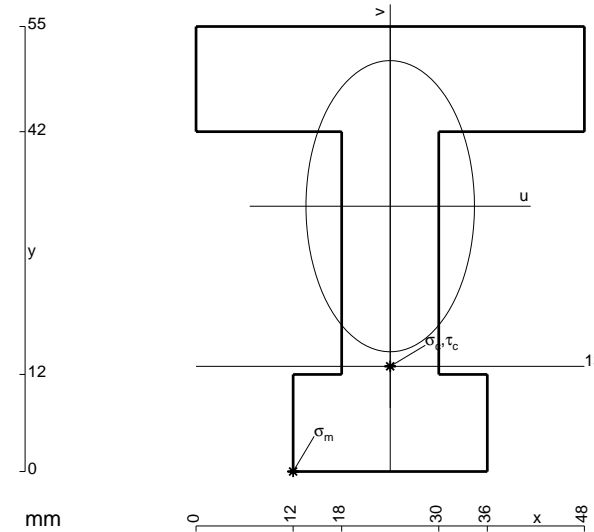

- A = 1272. mm²
- J_u = 412017. mm⁴
- J_v = 137952. mm⁴
- y_g = 32.79 mm
- T_y = -4820. N
- M_x = -2506400. Nmm
- x_m = 12. mm
- u_m = -12. mm
- v_m = -32.79 mm
- σ_m = -Mv/J_u = -199.5 N/mm²
- x_c = 24. mm
- y_c = 13. mm
- v_c = -19.79 mm
- σ_c = -Mv/J_u = -120.4 N/mm²
- τ_c = 7.76 N/mm²
- σ_o = √σ²+3τ² = 121.2 N/mm²
- S = 7960. mm³

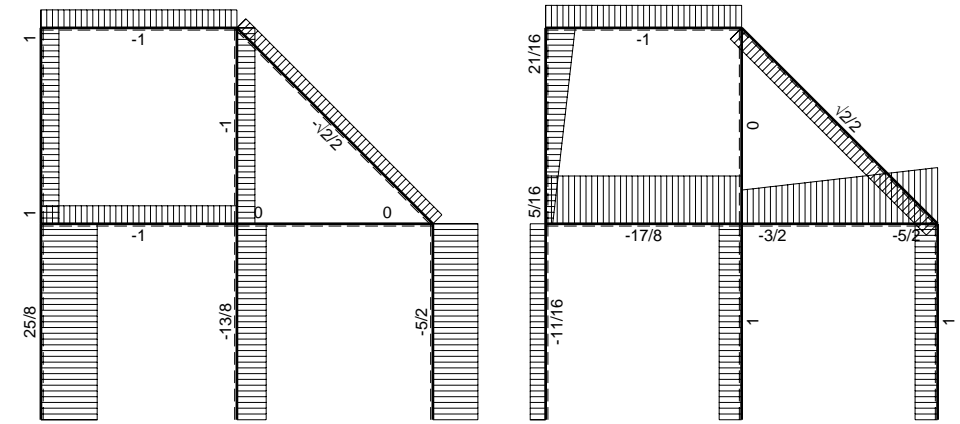
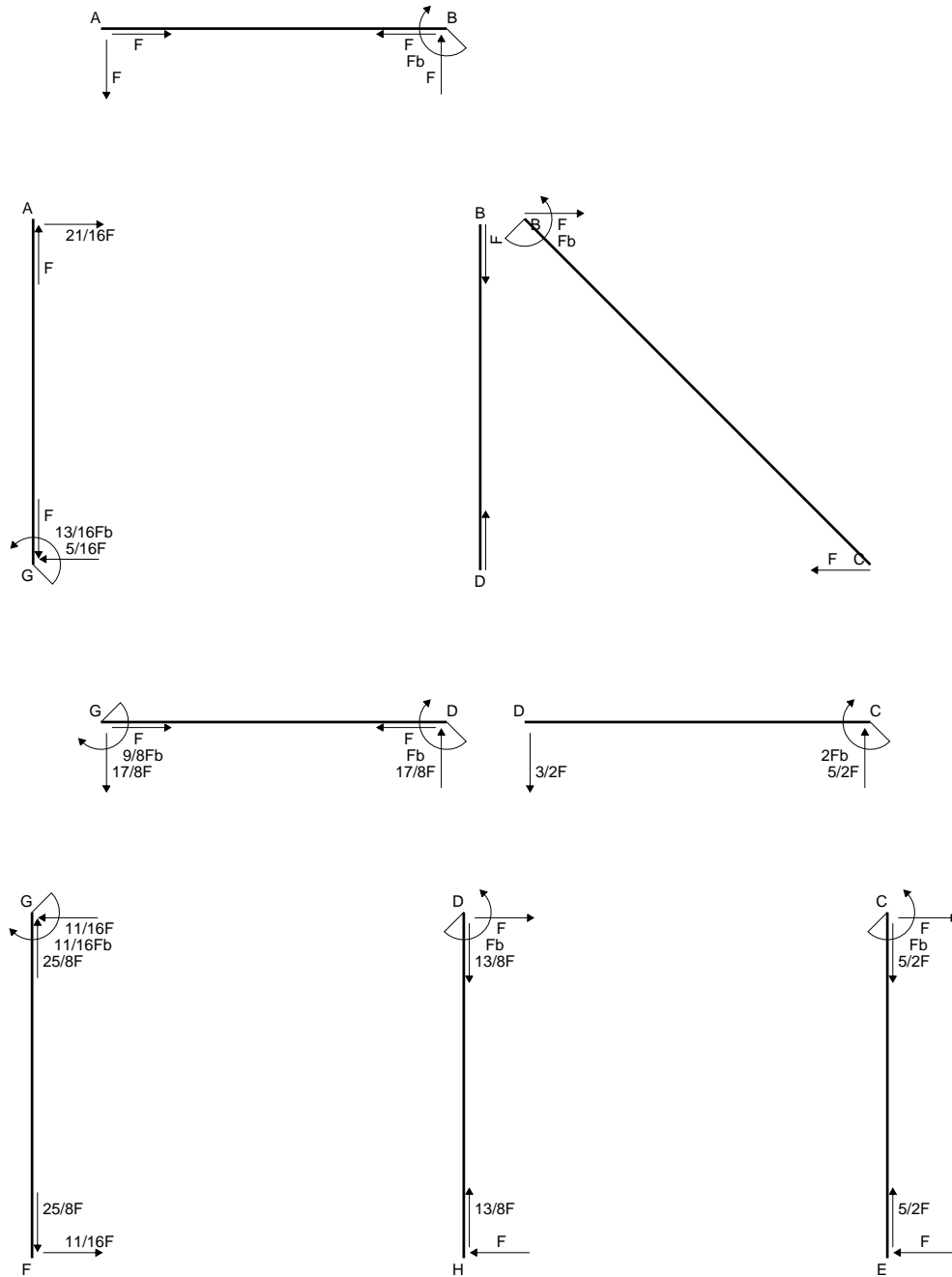

← ⊕ → F

↑ ⊕ ↓ F

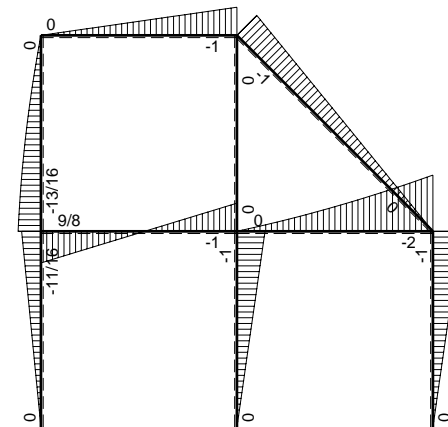

⊕ ⊖ Fb

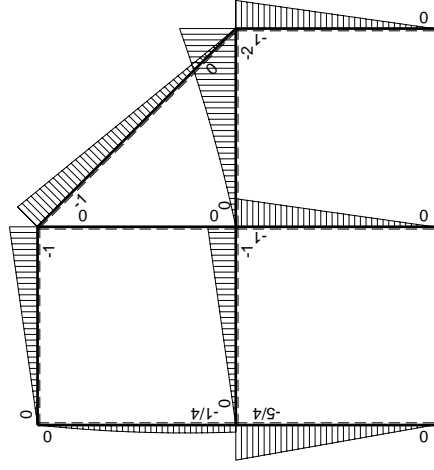
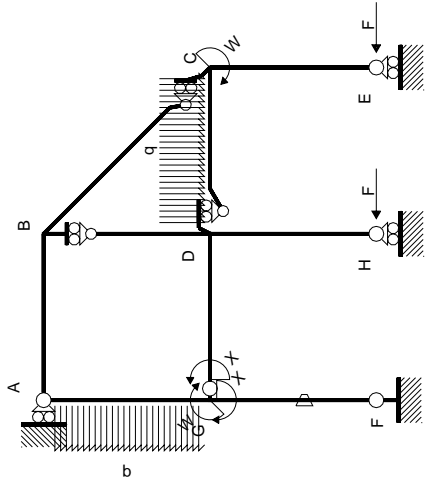

Schema di calcolo iperstatico

M_0 flessione da carichi assegnati

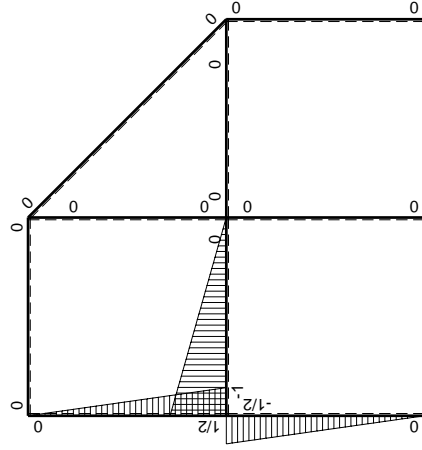

M_x flessione da iperstatica $X=1$

Quadro contributi PLV per iperstatica $X=W_{GD}$

→	$M_x(x)$	$M_o(x)$	θ	$M_x M_o$	$M_x \theta$	$M_x M_x$	$\int M_x(M_o/EJ+\theta)dx$	$\int X M_x M_x/EJdx$
AB b	0	-Fx	0	0	0	0	0+0	0
BA b	0	Fb-Fx	0	0	0	0	0	0
BC $\sqrt{2}b$	0	-Fb+ $\sqrt{2}/2Fx$	0	0	0	0	0	0
BD b	0	0	0	0	0	0	0+0	0
DB b	0	0	0	0	0	0	0	0
DC b	0	-3/2Fx-1/2qx ²	0	0	0	0	0+0	0
CD b	0	2Fb-5/2Fx+1/2qx ²	0	0	0	0	0	0
CE b	0	-Fb+Fx	0	0	0	0	0+0	0
EC b	0	Fx	0	0	0	0	0	0
FG b	-1/2x/b	-5/4Fx	-Fb/EJ	5/8Fx ² /b	1/2Fx/EJ	1/4x ² /b ²	(5/24+1/4)Fb ² /EJ	1/12Xb/EJ
GF b	1/2-1/2x/b	5/4Fb-5/4Fx	Fb/EJ	5/8Fb-5/4Fx+5/8Fx ² /b	1/2Fb/EJ-1/2Fx/EJ	1/4-1/2x/b+1/4x ² /b ²		
GD b	-1+x/b	-Fx	0	Fx-Fx ² /b	0	1-2x/b+x ² /b ²	(1/6+0)Fb ² /EJ	1/3Xb/EJ
DG b	x/b	Fb-Fx	0	Fx-Fx ² /b	0	x ² /b ²		
DH b	0	-Fb+Fx	0	0	0	0	0+0	0
HD b	0	Fx	0	0	0	0	0	0
GA b	1/2-1/2x/b	-1/4Fb-1/4Fx+1/2qx ²	0	-1/8Fb+3/8Fx ² /b-1/4qx ³ /b	0	1/4-1/2x/b+1/4x ² /b ²	(-1/16+0)Fb ² /EJ	1/12Xb/EJ
AG b	-1/2x/b	3/4Fx-1/2qx ²	0	-3/8Fx ² /b+1/4qx ³ /b	0	1/4x ² /b ²		
	totali						9/16Fb ² /EJ	1/2Xb/EJ
	iperstatica $X=W_{GD}$						-9/8Fb	

Sviluppi di calcolo iperstatica

$$L_{FG}^{xx} = \int_0^b (1/4 x^2/b^2) 1/EJ dx = [1/12 x^3/b^2]_0^b 1/EJ$$

$$= (1/12 b) 1/EJ = 1/12 b/EJ$$

$$L_{GF}^{xx} = \int_0^b (1/4 - 1/2 x/b + 1/4 x^2/b^2) 1/EJ dx = [1/4 x - 1/4 x^2/b + 1/12 x^3/b^2]_0^b 1/EJ$$

$$= (1/4 b - 1/4 b + 1/12 b) 1/EJ = 1/12 b/EJ$$

$$L_{GD}^{xx} = \int_0^b (1 - 2 x/b + x^2/b^2) 1/EJ dx = [x - x^2/b + 1/3 x^3/b^2]_0^b 1/EJ$$

$$= (b - b + 1/3 b) 1/EJ = 1/3 b/EJ$$

$$L_{DG}^{xx} = \int_0^b (x^2/b^2) 1/EJ dx = [1/3 x^3/b^2]_0^b 1/EJ$$

$$= (1/3 b) 1/EJ = 1/3 b/EJ$$

$$L_{GA}^{xx} = \int_0^b (1/4 - 1/2 x/b + 1/4 x^2/b^2) 1/EJ dx = [1/4 x - 1/4 x^2/b + 1/12 x^3/b^2]_0^b 1/EJ$$

$$= (1/4 b - 1/4 b + 1/12 b) 1/EJ = 1/12 b/EJ$$

$$L_{AG}^{xx} = \int_0^b (1/4 x^2/b^2) 1/EJ dx = [1/12 x^3/b^2]_0^b 1/EJ$$

$$= (1/12 b) 1/EJ = 1/12 b/EJ$$

$$L_{FG}^{xo} = \int_0^b (5/8 x^2/b^2) Fb 1/EJ dx + \int_0^b (1/2 x/b) \theta dx = [5/24 x^3/b^2]_0^b Fb 1/EJ + [1/4 x^2/b]_0^b \theta$$

$$= (5/24 b) Fb 1/EJ + (1/4 b) \theta = 11/24 Fb^2/EJ$$

$$L_{GF}^{xo} = \int_0^b (5/8 - 5/4 x/b + 5/8 x^2/b^2) Fb 1/EJ dx + \int_0^b (-1/2 + 1/2 x/b) \theta dx$$

$$= [5/8 x - 5/8 x^2/b + 5/24 x^3/b^2]_0^b Fb 1/EJ + [-1/2 x + 1/4 x^2/b]_0^b \theta$$

$$= (5/8 b - 5/8 b + 5/24 b) Fb 1/EJ + (-1/2 b + 1/4 b) \theta = 11/24 Fb^2/EJ$$

$$L_{GD}^{xo} = \int_0^b (x/b - x^2/b^2) Fb 1/EJ dx = [1/2 x^2/b - 1/3 x^3/b^2]_0^b Fb 1/EJ$$

$$= (1/2 b - 1/3 b) Fb 1/EJ = 1/6 Fb^2/EJ$$

$$L_{DG}^{xo} = \int_0^b (x/b - x^2/b^2) Fb 1/EJ dx = [1/2 x^2/b - 1/3 x^3/b^2]_0^b Fb 1/EJ$$

$$= (1/2 b - 1/3 b) Fb 1/EJ = 1/6 Fb^2/EJ$$

$$L_{GA}^{xo} = \int_0^b (-1/8 + 3/8 x^2/b^2 - 1/4 x^3/b^3) Fb 1/EJ dx = [-1/8 x + 1/8 x^3/b^2 - 1/16 x^4/b^3]_0^b Fb 1/EJ$$

$$= (-1/8 b + 1/8 b - 1/16 b) Fb 1/EJ = -1/16 Fb^2/EJ$$

$$L_{AG}^{xo} = \int_0^b (-3/8 x^2/b^2 + 1/4 x^3/b^3) Fb 1/EJ dx = [-1/8 x^3/b^2 + 1/16 x^4/b^3]_0^b Fb 1/EJ$$

$$= (-1/8 b + 1/16 b) Fb 1/EJ = -1/16 Fb^2/EJ$$

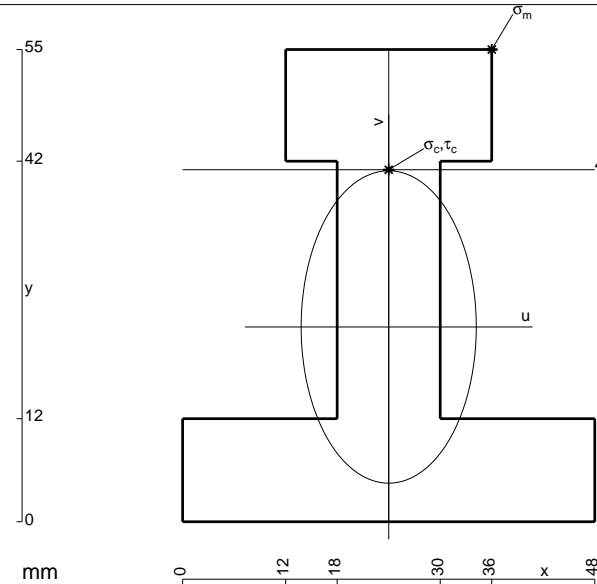

- A = 1248. mm²
- J_u = 413282. mm⁴
- J_v = 129888. mm⁴
- y_g = 22.68 mm
- T_y = -5875. N
- M_x = -2679000. Nmm
- x_m = 36. mm
- y_m = 55. mm
- u_m = 12. mm
- v_m = 32.32 mm
- σ_m = -Mv/J_u = 209.5 N/mm²
- x_c = 24. mm
- y_c = 41. mm
- v_c = 18.32 mm
- σ_c = -Mv/J_u = 118.7 N/mm²
- τ_c = 9.81 N/mm²
- σ_q = √σ²+3τ² = 119.9 N/mm²
- S = 8281. mm³

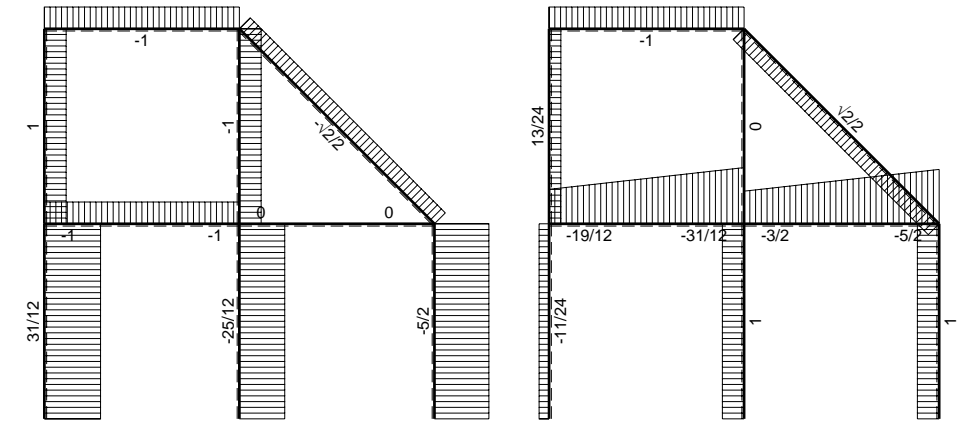
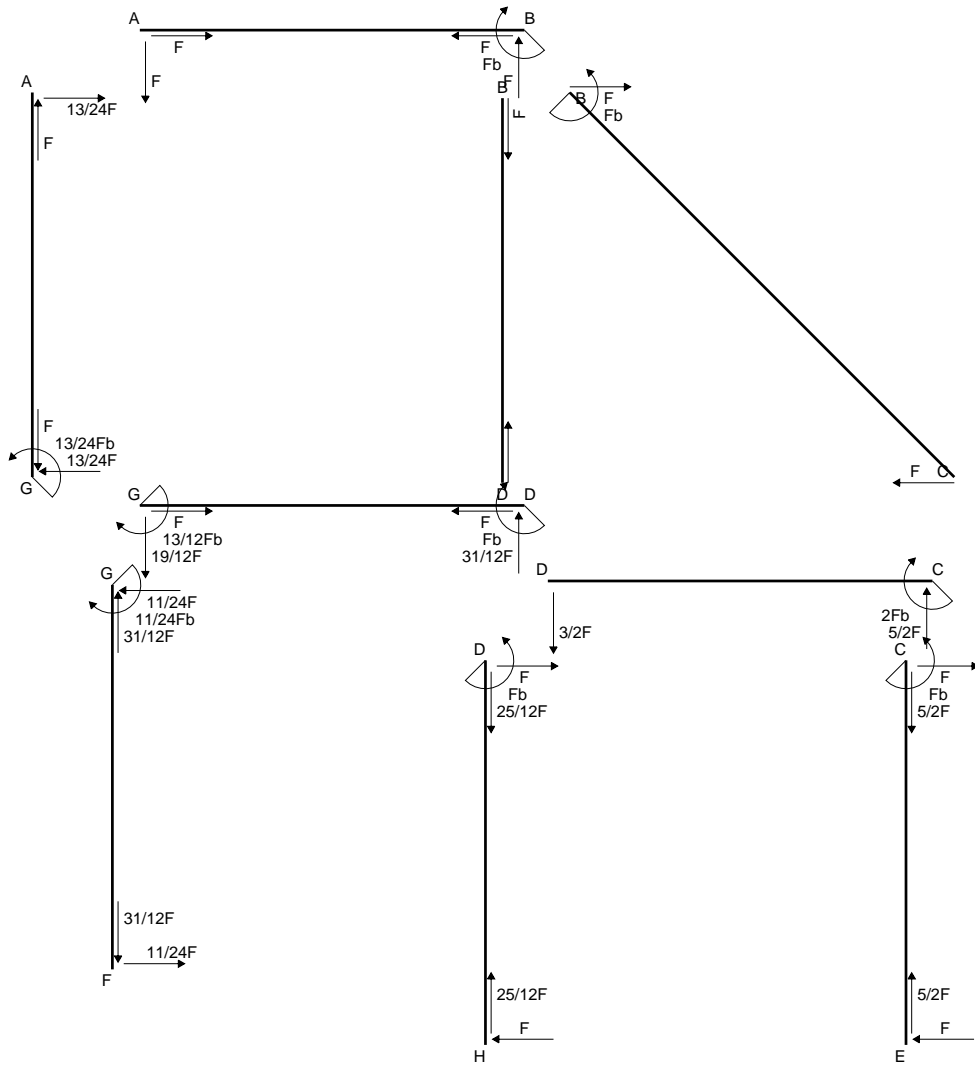

← ⊕ → F

↑ ⊕ ↓ F

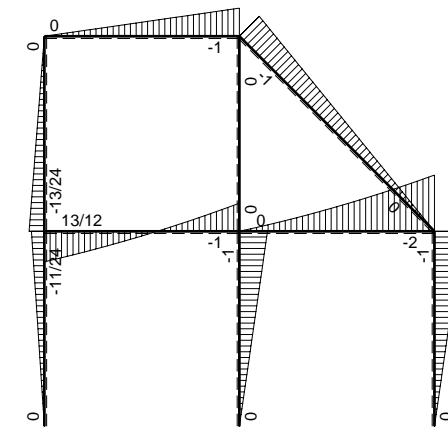

⊕ ⊖ Fb

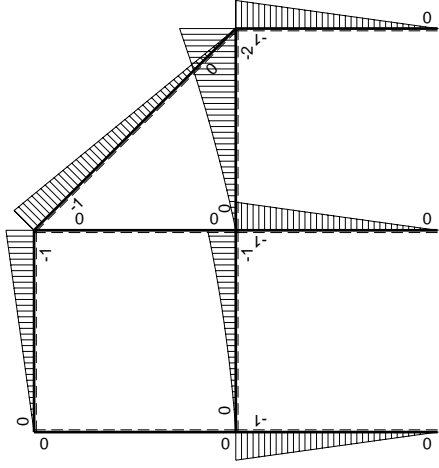
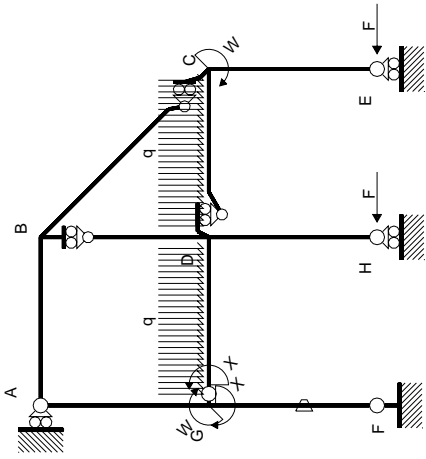

Schema di calcolo iperstatico

M_0 flessione da carichi assegnati

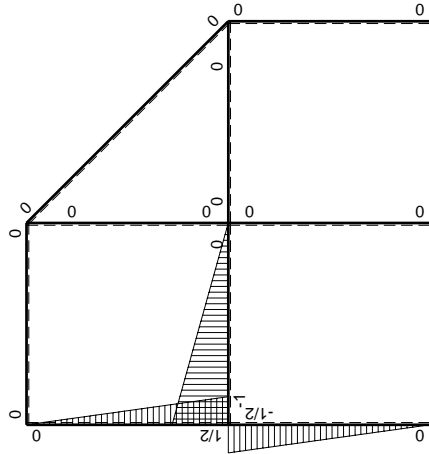

M_x flessione da iperstatica $X=1$

Quadro contributi PLV per iperstatica $X=W_{GD}$

→	$M_x(x)$	$M_o(x)$	θ	$M_x M_o$	$M_x \theta$	$M_x M_x$	$\int M_x(M_o/EJ+\theta)dx$	$\int x M_x M_x/EJ dx$	
AB b	0	-Fx	0	0	0	0	0+0	0	
BA b	0	Fb-Fx	0	0	0	0			
BC $\sqrt{2}b$	0	-Fb+ $\sqrt{2}/2Fx$	0	0	0	0	0	0	
BD b	0	0	0	0	0	0	0+0	0	
DB b	0	0	0	0	0	0			
DC b	0	-3/2Fx-1/2qx ²	0	0	0	0	0+0	0	
CD b	0	2Fb-5/2Fx+1/2qx ²	0	0	0	0			
CE b	0	-Fb+Fx	0	0	0	0	0+0	0	
EC b	0	Fx	0	0	0	0			
FG b	-1/2x/b	-Fx	-Fb/EJ	1/2Fx ² /b	1/2Fx/EJ	1/4x ² /b ²	(1/6+1/4)Fb ² /EJ	1/12Xb/EJ	
GF b	1/2-1/2x/b	Fb-Fx	Fb/EJ	1/2Fb-Fx+1/2Fx ² /b	1/2Fb/EJ-1/2Fx/EJ	1/4-1/2x/b+1/4x ² /b ²			
GD b	-1+x/b	-1/2Fx-1/2qx ²	0	1/2Fx-1/2qx ³ /b	0	1-2x/b+x ² /b ²	(1/8+0)Fb ² /EJ	1/3Xb/EJ	
DG b	x/b	Fb-3/2Fx+1/2qx ²	0	Fx-3/2Fx ² /b+1/2qx ³ /b	0	x ² /b ²			
DH b	0	-Fb+Fx	0	0	0	0	0+0	0	
HD b	0	Fx	0	0	0	0			
GA b	1/2-1/2x/b	0	0	0	0	1/4-1/2x/b+1/4x ² /b ²	0+0	1/12Xb/EJ	
AG b	-1/2x/b	0	0	0	0	1/4x ² /b ²			
	totali							13/24Fb ² /EJ	1/2Xb/EJ
	iperstatica $X=W_{GD}$							-13/12Fb	

Sviluppi di calcolo iperstatica

$$L_{FG}^{xx} = \int_0^b (1/4 x^2/b^2) 1/EJ dx = [1/12 x^3/b^2]_0^b 1/EJ$$

$$= (1/12 b) 1/EJ = 1/12 b/EJ$$

$$L_{GF}^{xx} = \int_0^b (1/4 - 1/2 x/b + 1/4 x^2/b^2) 1/EJ dx = [1/4 x - 1/4 x^2/b + 1/12 x^3/b^2]_0^b 1/EJ$$

$$= (1/4 b - 1/4 b + 1/12 b) 1/EJ = 1/12 b/EJ$$

$$L_{GD}^{xx} = \int_0^b (1 - 2 x/b + x^2/b^2) 1/EJ dx = [x - x^2/b + 1/3 x^3/b^2]_0^b 1/EJ$$

$$= (b - b + 1/3 b) 1/EJ = 1/3 b/EJ$$

$$L_{DG}^{xx} = \int_0^b (x^2/b^2) 1/EJ dx = [1/3 x^3/b^2]_0^b 1/EJ$$

$$= (1/3 b) 1/EJ = 1/3 b/EJ$$

$$L_{GA}^{xx} = \int_0^b (1/4 - 1/2 x/b + 1/4 x^2/b^2) 1/EJ dx = [1/4 x - 1/4 x^2/b + 1/12 x^3/b^2]_0^b 1/EJ$$

$$= (1/4 b - 1/4 b + 1/12 b) 1/EJ = 1/12 b/EJ$$

$$L_{AG}^{xx} = \int_0^b (1/4 x^2/b^2) 1/EJ dx = [1/12 x^3/b^2]_0^b 1/EJ$$

$$= (1/12 b) 1/EJ = 1/12 b/EJ$$

$$L_{FG}^{xo} = \int_0^b (1/2 x^2/b^2) Fb 1/EJ dx + \int_0^b (1/2 x/b) \theta dx = [1/6 x^3/b^2]_0^b Fb 1/EJ + [1/4 x^2/b]_0^b \theta$$

$$= (1/6 b) Fb 1/EJ + (1/4 b) \theta = 5/12 Fb^2/EJ$$

$$L_{GF}^{xo} = \int_0^b (1/2 - x/b + 1/2 x^2/b^2) Fb 1/EJ dx + \int_0^b (-1/2 + 1/2 x/b) \theta dx$$

$$= [1/2 x - 1/2 x^2/b + 1/6 x^3/b^2]_0^b Fb 1/EJ + [-1/2 x + 1/4 x^2/b]_0^b \theta$$

$$= (1/2 b - 1/2 b + 1/6 b) Fb 1/EJ + (-1/2 b + 1/4 b) \theta = 5/12 Fb^2/EJ$$

$$L_{GD}^{xo} = \int_0^b (1/2 x/b - 1/2 x^3/b^3) Fb 1/EJ dx = [1/4 x^2/b - 1/8 x^4/b^3]_0^b Fb 1/EJ$$

$$= (1/4 b - 1/8 b) Fb 1/EJ = 1/8 Fb^2/EJ$$

$$L_{DG}^{xo} = \int_0^b (x/b - 3/2 x^2/b^2 + 1/2 x^3/b^3) Fb 1/EJ dx = [1/2 x^2/b - 1/2 x^3/b^2 + 1/8 x^4/b^3]_0^b Fb 1/EJ$$

$$= (1/2 b - 1/2 b + 1/8 b) Fb 1/EJ = 1/8 Fb^2/EJ$$

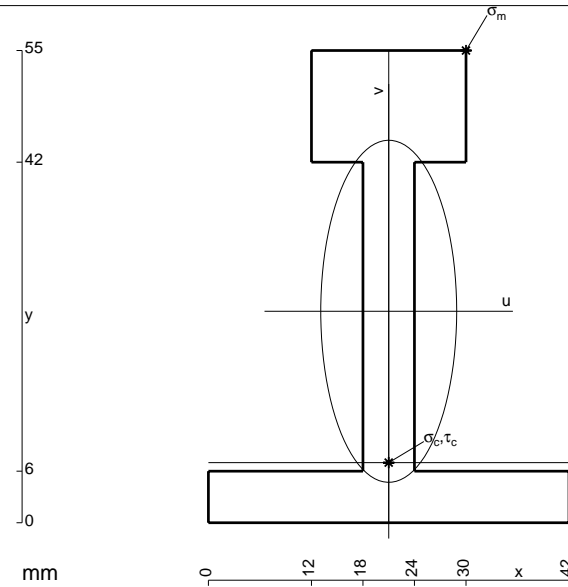

- A = 702. mm²
- J_u = 278693. mm⁴
- J_v = 44010. mm⁴
- y_g = 24.63 mm
- T_y = -4050. N
- M_x = -2008800. Nmm
- x_m = 30. mm
- y_m = 55. mm
- u_m = 9. mm
- v_m = 30.37 mm
- σ_m = -Mv/J_u = 218.9 N/mm²
- x_c = 21. mm
- y_c = 7. mm
- v_c = -17.63 mm
- σ_c = -Mv/J_u = -127.1 N/mm²
- τ_c = 13.46 N/mm²
- σ_q = √σ²+3τ² = 129.2 N/mm²
- S = 5559. mm³

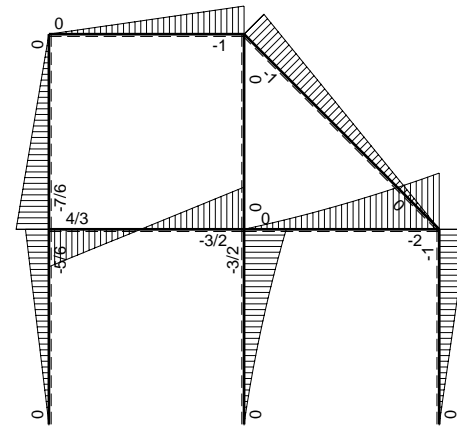
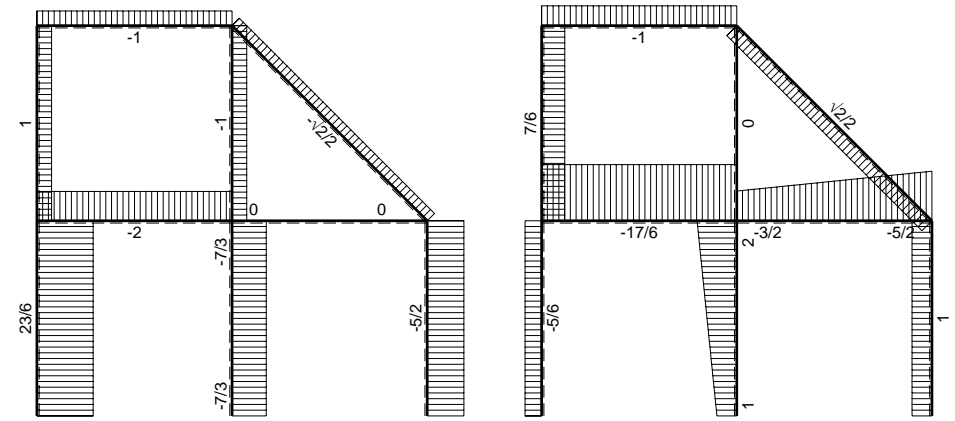
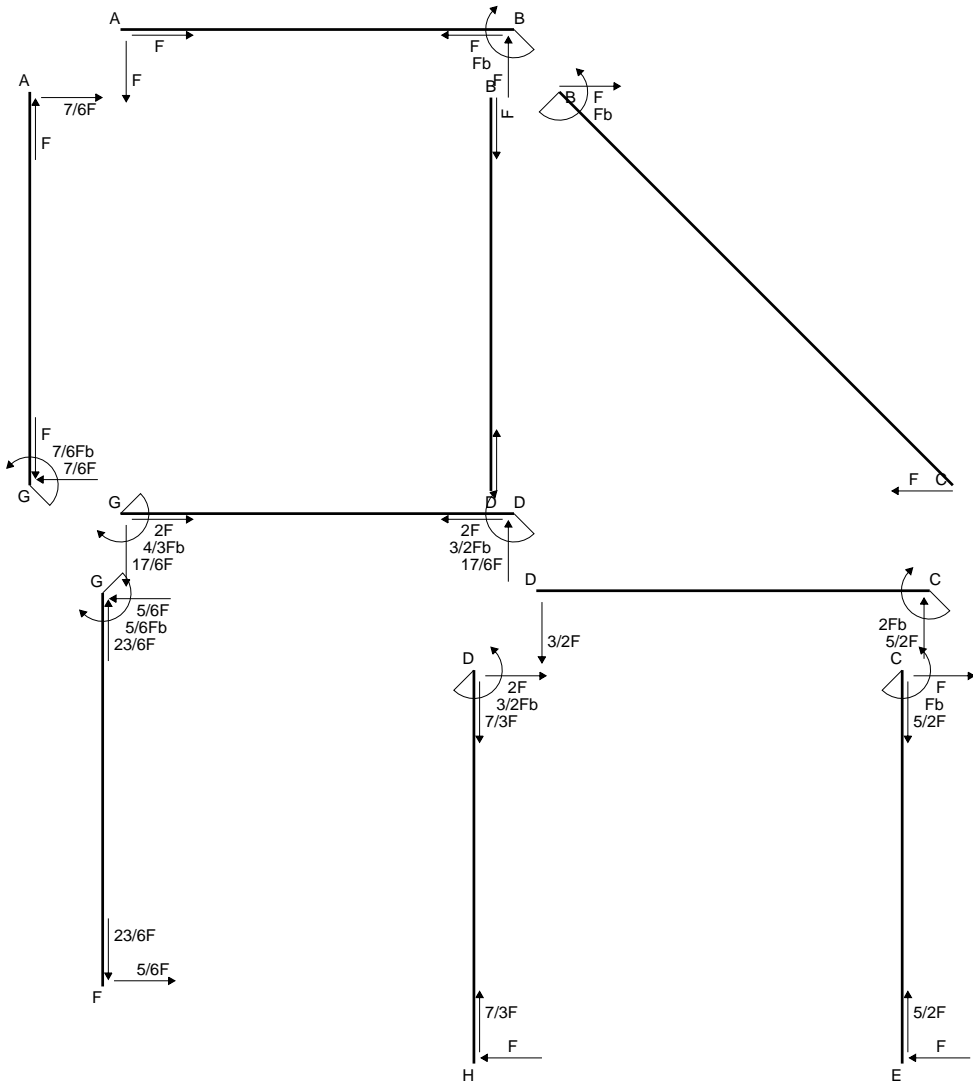

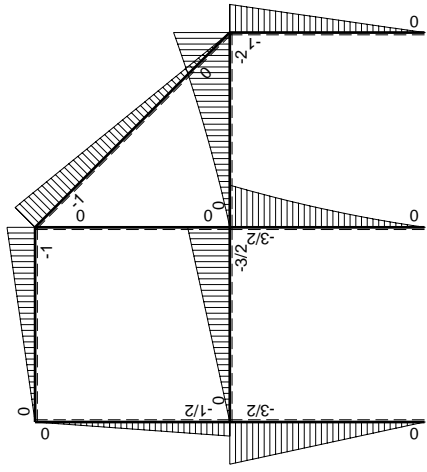
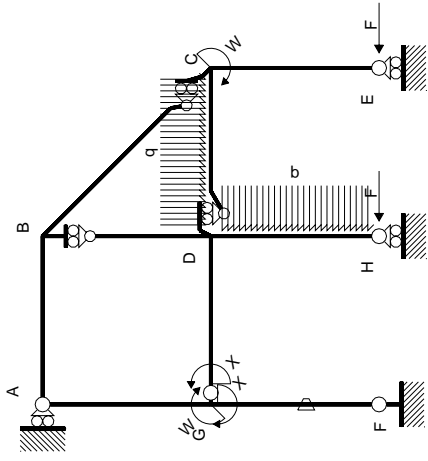

Schema di calcolo iperstatico

M_0 flessione da carichi assegnati

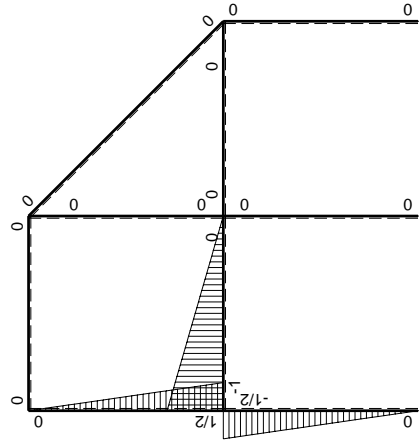

M_x flessione da iperstatica $X=1$

Quadro contributi PLV per iperstatica $X=W_{GD}$

→	$M_x(x)$	$M_o(x)$	θ	$M_x M_o$	$M_x \theta$	$M_x M_x$	$\int M_x(M_o/EJ+\theta)dx$	$\int X M_x M_x/EJdx$
AB b	0	-Fx	0	0	0	0	0+0	0
BA b	0	Fb-Fx	0	0	0	0	0	0
BC $\sqrt{2}b$	0	-Fb+ $\sqrt{2}/2Fx$	0	0	0	0	0	0
BD b	0	0	0	0	0	0	0+0	0
DB b	0	0	0	0	0	0	0	0
DC b	0	-3/2Fx-1/2qx ²	0	0	0	0	0+0	0
CD b	0	2Fb-5/2Fx+1/2qx ²	0	0	0	0	0	0
CE b	0	-Fb+Fx	0	0	0	0	0+0	0
EC b	0	Fx	0	0	0	0	0	0
FG b	-1/2x/b	-3/2Fx	-Fb/EJ	3/4Fx ² /b	1/2Fx/EJ	1/4x ² /b ²	(1/4+1/4)Fb ² /EJ	1/12Xb/EJ
GF b	1/2-1/2x/b	3/2Fb-3/2Fx	Fb/EJ	3/4Fb-3/2Fx+3/4Fx ² /b	1/2Fb/EJ-1/2Fx/EJ	1/4-1/2x/b+1/4x ² /b ²		
GD b	-1+x/b	-3/2Fx	0	3/2Fx-3/2Fx ² /b	0	1-2x/b+x ² /b ²	(1/4+0)Fb ² /EJ	1/3Xb/EJ
DG b	x/b	3/2Fb-3/2Fx	0	3/2Fx-3/2Fx ² /b	0	x ² /b ²		
DH b	0	-3/2Fb+2Fx-1/2qx ²	0	0	0	0	0+0	0
HD b	0	Fx+1/2qx ²	0	0	0	0	0	0
GA b	1/2-1/2x/b	-1/2Fb+1/2Fx	0	-1/4Fb+1/2Fx-1/4Fx ² /b	0	1/4-1/2x/b+1/4x ² /b ²	(-1/12+0)Fb ² /EJ	1/12Xb/EJ
AG b	-1/2x/b	1/2Fx	0	-1/4Fx ² /b	0	1/4x ² /b ²		
	totali						2/3Fb ² /EJ	1/2Xb/EJ
	iperstatica $X=W_{GD}$						-4/3Fb	

Sviluppi di calcolo iperstatica

$$L_{FG}^{xx} = \int_0^b (1/4 x^2/b^2) 1/EJ dx = [1/12 x^3/b^2]_0^b 1/EJ$$

$$= (1/12 b) 1/EJ = 1/12 b/EJ$$

$$L_{GF}^{xx} = \int_0^b (1/4 - 1/2 x/b + 1/4 x^2/b^2) 1/EJ dx = [1/4 x - 1/4 x^2/b + 1/12 x^3/b^2]_0^b 1/EJ$$

$$= (1/4 b - 1/4 b + 1/12 b) 1/EJ = 1/12 b/EJ$$

$$L_{GD}^{xx} = \int_0^b (1 - 2 x/b + x^2/b^2) 1/EJ dx = [x - x^2/b + 1/3 x^3/b^2]_0^b 1/EJ$$

$$= (b - b + 1/3 b) 1/EJ = 1/3 b/EJ$$

$$L_{DG}^{xx} = \int_0^b (x^2/b^2) 1/EJ dx = [1/3 x^3/b^2]_0^b 1/EJ$$

$$= (1/3 b) 1/EJ = 1/3 b/EJ$$

$$L_{GA}^{xx} = \int_0^b (1/4 - 1/2 x/b + 1/4 x^2/b^2) 1/EJ dx = [1/4 x - 1/4 x^2/b + 1/12 x^3/b^2]_0^b 1/EJ$$

$$= (1/4 b - 1/4 b + 1/12 b) 1/EJ = 1/12 b/EJ$$

$$L_{AG}^{xx} = \int_0^b (1/4 x^2/b^2) 1/EJ dx = [1/12 x^3/b^2]_0^b 1/EJ$$

$$= (1/12 b) 1/EJ = 1/12 b/EJ$$

$$L_{FG}^{xo} = \int_0^b (3/4 x^2/b^2) Fb 1/EJ dx + \int_0^b (1/2 x/b) \theta dx = [1/4 x^3/b^2]_0^b Fb 1/EJ + [1/4 x^2/b]_0^b \theta$$

$$= (1/4 b) Fb 1/EJ + (1/4 b) \theta = 1/2 Fb^2/EJ$$

$$L_{GF}^{xo} = \int_0^b (3/4 - 3/2 x/b + 3/4 x^2/b^2) Fb 1/EJ dx + \int_0^b (-1/2 + 1/2 x/b) \theta dx$$

$$= [3/4 x - 3/4 x^2/b + 1/4 x^3/b^2]_0^b Fb 1/EJ + [-1/2 x + 1/4 x^2/b]_0^b \theta$$

$$= (3/4 b - 3/4 b + 1/4 b) Fb 1/EJ + (-1/2 b + 1/4 b) \theta = 1/2 Fb^2/EJ$$

$$L_{GD}^{xo} = \int_0^b (3/2 x/b - 3/2 x^2/b^2) Fb 1/EJ dx = [3/4 x^2/b - 1/2 x^3/b^2]_0^b Fb 1/EJ$$

$$= (3/4 b - 1/2 b) Fb 1/EJ = 1/4 Fb^2/EJ$$

$$L_{DG}^{xo} = \int_0^b (3/2 x/b - 3/2 x^2/b^2) Fb 1/EJ dx = [3/4 x^2/b - 1/2 x^3/b^2]_0^b Fb 1/EJ$$

$$= (3/4 b - 1/2 b) Fb 1/EJ = 1/4 Fb^2/EJ$$

$$L_{GA}^{xo} = \int_0^b (-1/4 + 1/2 x/b - 1/4 x^2/b^2) Fb 1/EJ dx = [-1/4 x + 1/4 x^2/b - 1/12 x^3/b^2]_0^b Fb 1/EJ$$

$$= (-1/4 b + 1/4 b - 1/12 b) Fb 1/EJ = -1/12 Fb^2/EJ$$

$$L_{AG}^{xo} = \int_0^b (-1/4 x^2/b^2) Fb 1/EJ dx = [-1/12 x^3/b^2]_0^b Fb 1/EJ$$

$$= (-1/12 b) Fb 1/EJ = -1/12 Fb^2/EJ$$

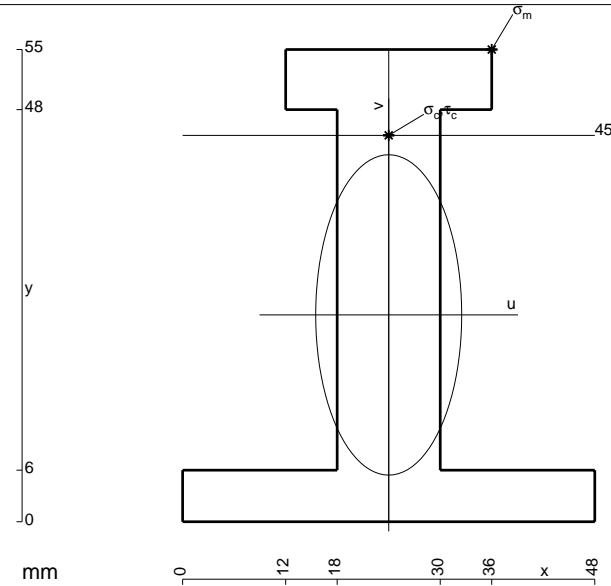

- A = 960. mm²
- J_u = 334225. mm⁴
- J_v = 69408. mm⁴
- y_g = 24.09 mm
- T_y = -4625. N
- M_x = -2479000. Nmm
- x_m = 36. mm
- y_m = 55. mm
- u_m = 12. mm
- v_m = 30.91 mm
- σ_m = -Mv/J_u = 229.3 N/mm²
- x_c = 24. mm
- y_c = 45. mm
- v_c = 20.91 mm
- σ_c = -Mv/J_u = 155.1 N/mm²
- τ_c = 6.241 N/mm²
- σ_q = √σ²+3τ² = 155.5 N/mm²
- S = 5412. mm³

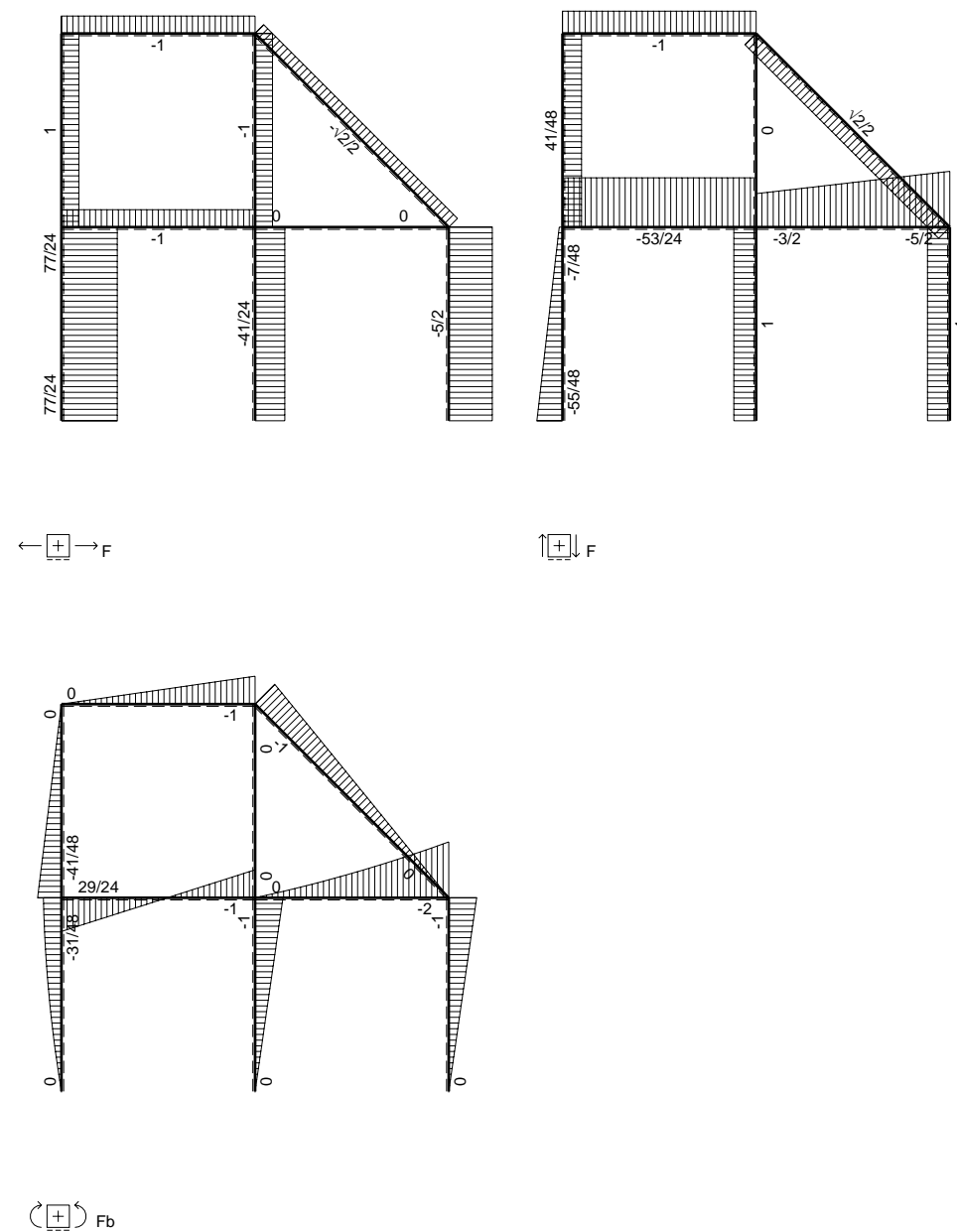
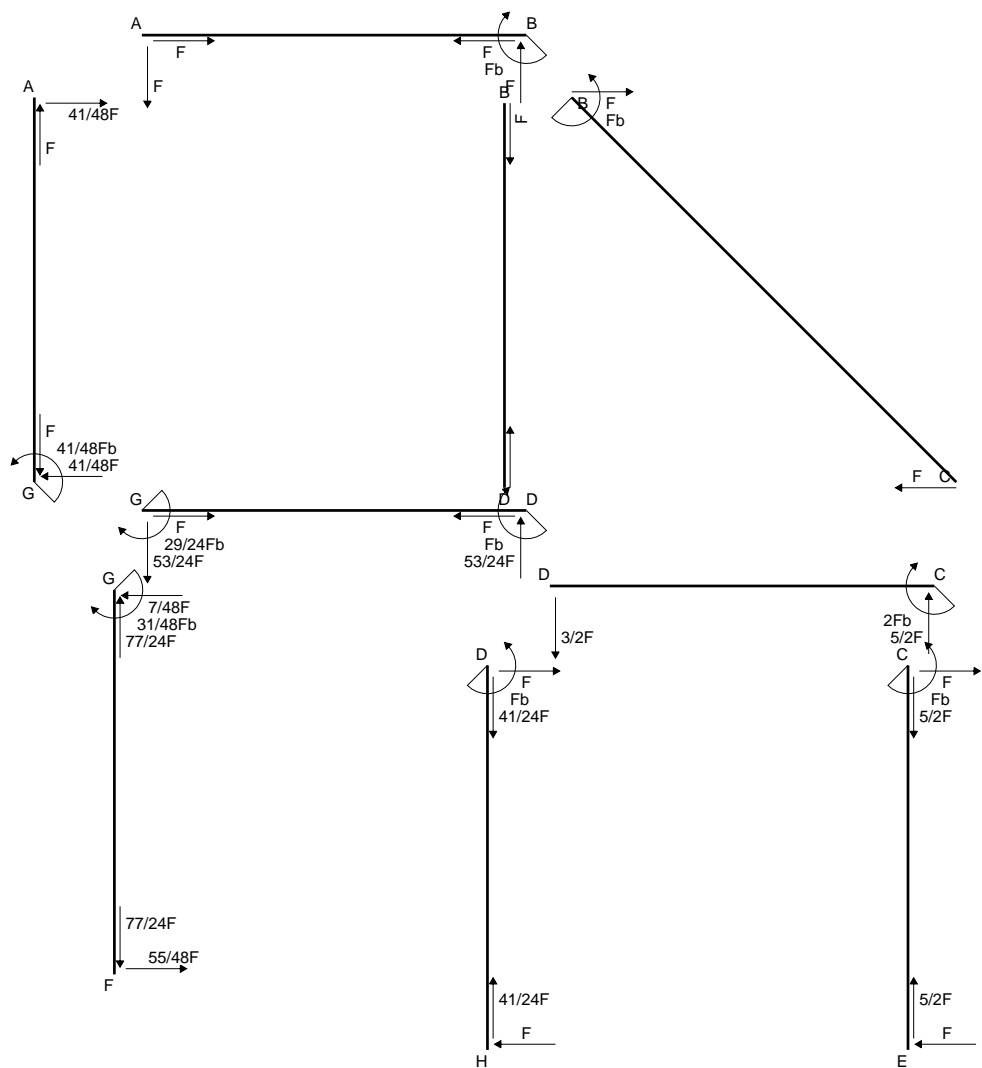

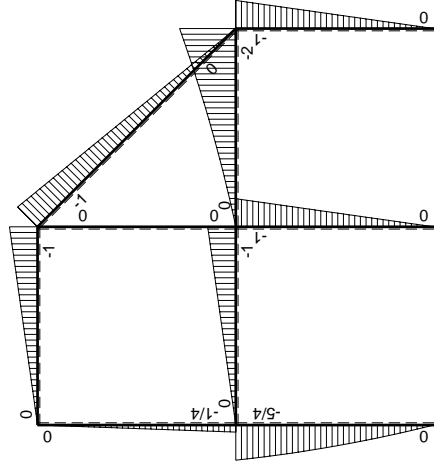
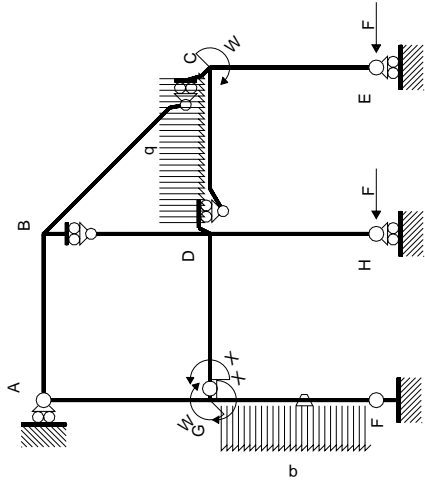

Schema di calcolo iperstatico

M_0 flessione da carichi assegnati

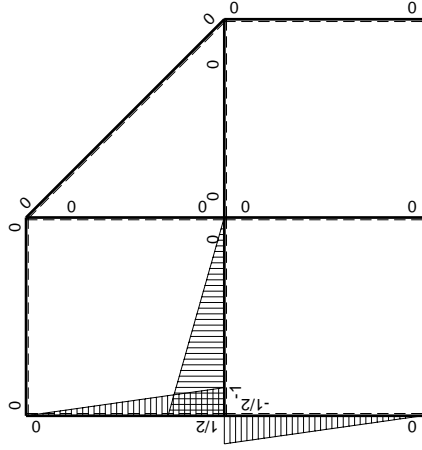

M_x flessione da iperstatica $X=1$

Quadro contributi PLV per iperstatica $X=W_{GD}$

→	$M_x(x)$	$M_o(x)$	θ	$M_x M_o$	$M_x \theta$	$M_x M_x$	$\int M_x(M_o/EJ+\theta)dx$	$\int X M_x M_x/EJdx$
AB b	0	-Fx	0	0	0	0	0+0	0
BA b	0	Fb-Fx	0	0	0	0	0	0
BC $\sqrt{2}b$	0	-Fb+ $\sqrt{2}/2Fx$	0	0	0	0	0	0
BD b	0	0	0	0	0	0	0+0	0
DB b	0	0	0	0	0	0	0	0
DC b	0	-3/2Fx-1/2qx ²	0	0	0	0	0+0	0
CD b	0	2Fb-5/2Fx+1/2qx ²	0	0	0	0	0	0
CE b	0	-Fb+Fx	0	0	0	0	0+0	0
EC b	0	Fx	0	0	0	0	0	0
FG b	-1/2x/b	-7/4Fx+1/2qx ²	-Fb/EJ	7/8Fx ² /b-1/4qx ³ /b	1/2Fx/EJ	1/4x ² /b ²	(11/48+1/4)Fb ² /EJ	1/12Xb/EJ
GF b	1/2-1/2x/b	5/4Fb-3/4Fx-1/2qx ²	Fb/EJ	5/8Fb-Fx+1/8Fx ² /b+1/4qx ³ /b	1/2Fb/EJ-1/2Fx/EJ	1/4-1/2x/b+1/4x ² /b ²		
GD b	-1+x/b	-Fx	0	Fx-Fx ² /b	0	1-2x/b+x ² /b ²	(1/6+0)Fb ² /EJ	1/3Xb/EJ
DG b	x/b	Fb-Fx	0	Fx-Fx ² /b	0	x ² /b ²		
DH b	0	-Fb+Fx	0	0	0	0	0+0	0
HD b	0	Fx	0	0	0	0	0	0
GA b	1/2-1/2x/b	-1/4Fb+1/4Fx	0	-1/8Fb+1/4Fx-1/8Fx ² /b	0	1/4-1/2x/b+1/4x ² /b ²	(-1/24+0)Fb ² /EJ	1/12Xb/EJ
AG b	-1/2x/b	1/4Fx	0	-1/8Fx ² /b	0	1/4x ² /b ²		
	totali						29/48Fb ² /EJ	1/2Xb/EJ
	iperstatica $X=W_{GD}$						-29/24Fb	

Sviluppi di calcolo iperstatica

$$L_{FG}^{xx} = \int_0^b (1/4 x^2/b^2) 1/EJ dx = [1/12 x^3/b^2]_0^b 1/EJ$$

$$= (1/12 b) 1/EJ = 1/12 b/EJ$$

$$L_{GF}^{xx} = \int_0^b (1/4 - 1/2 x/b + 1/4 x^2/b^2) 1/EJ dx = [1/4 x - 1/4 x^2/b + 1/12 x^3/b^2]_0^b 1/EJ$$

$$= (1/4 b - 1/4 b + 1/12 b) 1/EJ = 1/12 b/EJ$$

$$L_{GD}^{xx} = \int_0^b (1 - 2 x/b + x^2/b^2) 1/EJ dx = [x - x^2/b + 1/3 x^3/b^2]_0^b 1/EJ$$

$$= (b - b + 1/3 b) 1/EJ = 1/3 b/EJ$$

$$L_{DG}^{xx} = \int_0^b (x^2/b^2) 1/EJ dx = [1/3 x^3/b^2]_0^b 1/EJ$$

$$= (1/3 b) 1/EJ = 1/3 b/EJ$$

$$L_{GA}^{xx} = \int_0^b (1/4 - 1/2 x/b + 1/4 x^2/b^2) 1/EJ dx = [1/4 x - 1/4 x^2/b + 1/12 x^3/b^2]_0^b 1/EJ$$

$$= (1/4 b - 1/4 b + 1/12 b) 1/EJ = 1/12 b/EJ$$

$$L_{AG}^{xx} = \int_0^b (1/4 x^2/b^2) 1/EJ dx = [1/12 x^3/b^2]_0^b 1/EJ$$

$$= (1/12 b) 1/EJ = 1/12 b/EJ$$

$$L_{FG}^{xo} = \int_0^b (7/8 x^2/b^2 - 1/4 x^3/b^3) Fb 1/EJ dx + \int_0^b (1/2 x/b) \theta dx$$

$$= [7/24 x^3/b^2 - 1/16 x^4/b^3]_0^b Fb 1/EJ + [1/4 x^2/b]_0^b \theta$$

$$= (7/24 b - 1/16 b) Fb 1/EJ + (1/4 b) \theta = 23/48 Fb^2/EJ$$

$$L_{GF}^{xo} = \int_0^b (5/8 - x/b + 1/8 x^2/b^2 + 1/4 x^3/b^3) Fb 1/EJ dx + \int_0^b (-1/2 + 1/2 x/b) \theta dx$$

$$= [5/8 x - 1/2 x^2/b + 1/24 x^3/b^2 + 1/16 x^4/b^3]_0^b Fb 1/EJ + [-1/2 x + 1/4 x^2/b]_0^b \theta$$

$$= (5/8 b - 1/2 b + 1/24 b + 1/16 b) Fb 1/EJ + (-1/2 b + 1/4 b) \theta = 23/48 Fb^2/EJ$$

$$L_{GD}^{xo} = \int_0^b (x/b - x^2/b^2) Fb 1/EJ dx = [1/2 x^2/b - 1/3 x^3/b^2]_0^b Fb 1/EJ$$

$$= (1/2 b - 1/3 b) Fb 1/EJ = 1/6 Fb^2/EJ$$

$$L_{DG}^{xo} = \int_0^b (x/b - x^2/b^2) Fb 1/EJ dx = [1/2 x^2/b - 1/3 x^3/b^2]_0^b Fb 1/EJ$$

$$= (1/2 b - 1/3 b) Fb 1/EJ = 1/6 Fb^2/EJ$$

$$L_{GA}^{xo} = \int_0^b (-1/8 + 1/4 x/b - 1/8 x^2/b^2) Fb 1/EJ dx = [-1/8 x + 1/8 x^2/b - 1/24 x^3/b^2]_0^b Fb 1/EJ$$

$$= (-1/8 b + 1/8 b - 1/24 b) Fb 1/EJ = -1/24 Fb^2/EJ$$

$$L_{AG}^{xo} = \int_0^b (-1/8 x^2/b^2) Fb 1/EJ dx = [-1/24 x^3/b^2]_0^b Fb 1/EJ$$

$$= (-1/24 b) Fb 1/EJ = -1/24 Fb^2/EJ$$

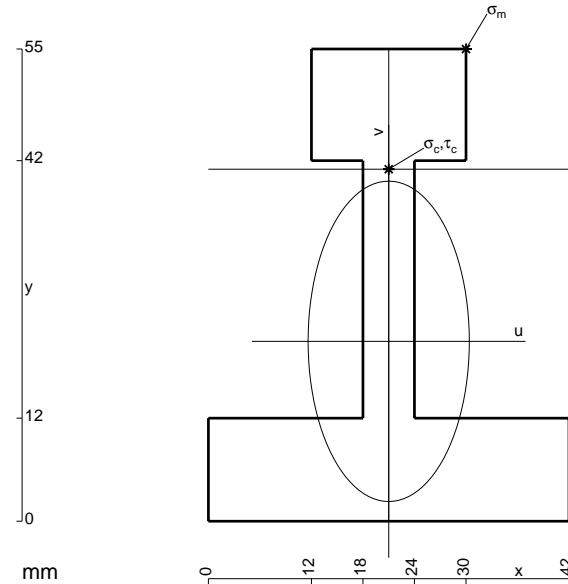

- A = 918. mm²
- J_u = 319684. mm⁴
- J_v = 80946. mm⁴
- y_g = 20.95 mm
- T_y = -3900. N
- M_x = -2246400. Nmm
- x_m = 30. mm
- y_m = 55. mm
- u_m = 9. mm
- v_m = 34.05 mm
- σ_m = -Mv/J_u = 239.3 N/mm²
- x_c = 21. mm
- y_c = 41. mm
- v_c = 20.05 mm
- σ_c = -Mv/J_u = 140.9 N/mm²
- τ_c = 13.36 N/mm²
- σ_o = √σ²+3τ² = 142.8 N/mm²
- S = 6570. mm³

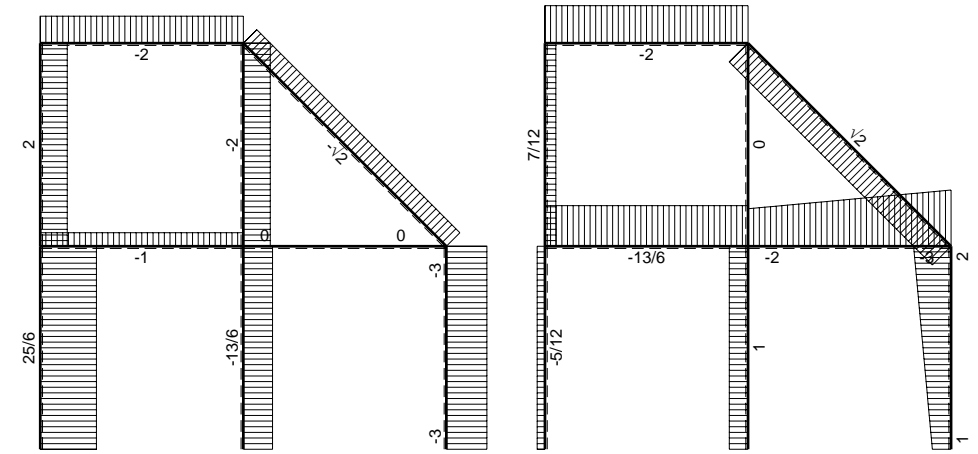
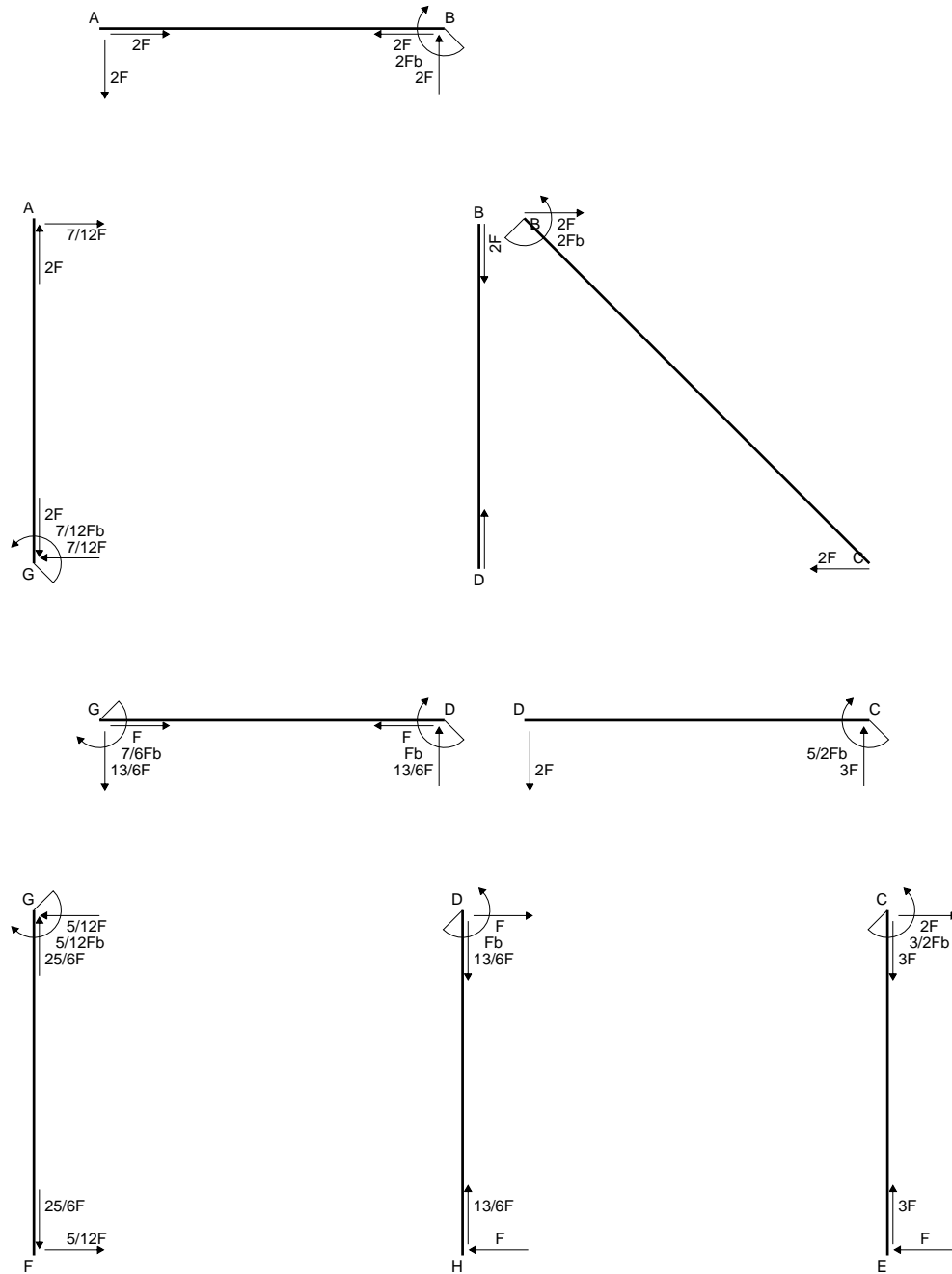

← ⊕ → F

↑ ⊕ ↓ F

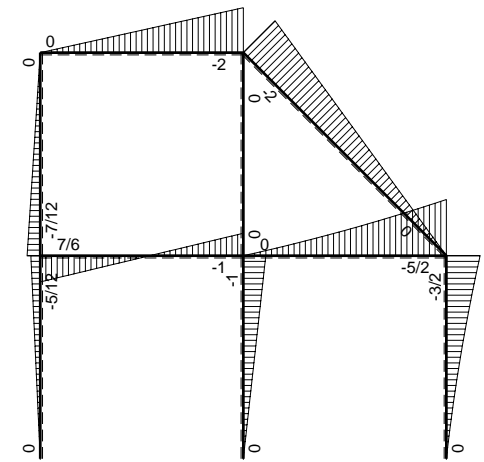

⊕ ⊖ F_b

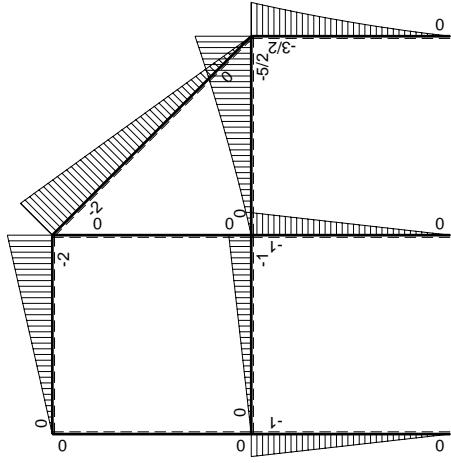
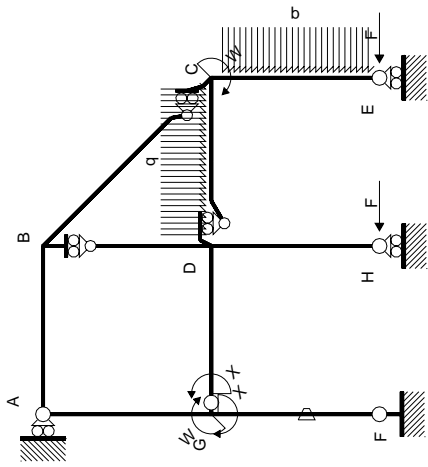

Schema di calcolo iperstatico

M_0 flessione da carichi assegnati

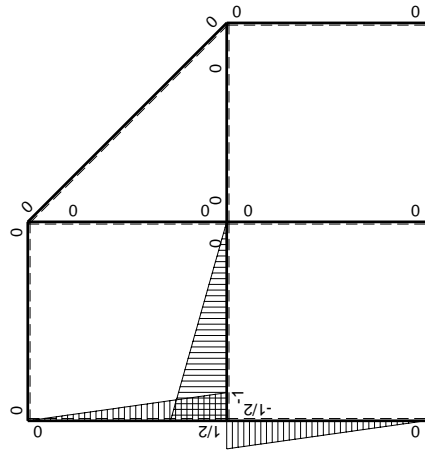

M_x flessione da iperstatica $X=1$

Quadro contributi PLV per iperstatica $X=W_{GD}$

→	$M_x(x)$	$M_o(x)$	θ	$M_x M_o$	$M_x \theta$	$M_x M_x$	$\int M_x(M_o/EJ+\theta)dx$	$\int x M_x M_x/EJ dx$	
AB b	0	-2Fx	0	0	0	0	0+0	0	
BA b	0	2Fb-2Fx	0	0	0	0			
BC $\sqrt{2}b$	0	-2Fb+ $\sqrt{2}Fx$	0	0	0	0	0	0	
BD b	0	0	0	0	0	0	0+0	0	
DB b	0	0	0	0	0	0			
DC b	0	-2Fx-1/2qx ²	0	0	0	0	0+0	0	
CD b	0	5/2Fb-3Fx+1/2qx ²	0	0	0	0			
CE b	0	-3/2Fb+2Fx-1/2qx ²	0	0	0	0	0+0	0	
EC b	0	Fx+1/2qx ²	0	0	0	0			
FG b	-1/2x/b	-Fx	-Fb/EJ	1/2Fx ² /b	1/2Fx/EJ	1/4x ² /b ²	(1/6+1/4)Fb ² /EJ	1/12Xb/EJ	
GF b	1/2-1/2x/b	Fb-Fx	Fb/EJ	1/2Fb-Fx+1/2Fx ² /b	1/2Fb/EJ-1/2Fx/EJ	1/4-1/2x/b+1/4x ² /b ²			
GD b	-1+x/b	-Fx	0	Fx-Fx ² /b	0	1-2x/b+x ² /b ²	(1/6+0)Fb ² /EJ	1/3Xb/EJ	
DG b	x/b	Fb-Fx	0	Fx-Fx ² /b	0	x ² /b ²			
DH b	0	-Fb+Fx	0	0	0	0	0+0	0	
HD b	0	Fx	0	0	0	0			
GA b	1/2-1/2x/b	0	0	0	0	1/4-1/2x/b+1/4x ² /b ²	0+0	1/12Xb/EJ	
AG b	-1/2x/b	0	0	0	0	1/4x ² /b ²			
	totali							7/12Fb ² /EJ	1/2Xb/EJ
	iperstatica $X=W_{GD}$							-7/6Fb	

Sviluppi di calcolo iperstatica

$$L_{FG}^{xx} = \int_0^b (1/4 x^2/b^2) 1/EJ dx = [1/12 x^3/b^2]_0^b 1/EJ$$

$$= (1/12 b) 1/EJ = 1/12 b/EJ$$

$$L_{GF}^{xx} = \int_0^b (1/4 - 1/2 x/b + 1/4 x^2/b^2) 1/EJ dx = [1/4 x - 1/4 x^2/b + 1/12 x^3/b^2]_0^b 1/EJ$$

$$= (1/4 b - 1/4 b + 1/12 b) 1/EJ = 1/12 b/EJ$$

$$L_{GD}^{xx} = \int_0^b (1 - 2 x/b + x^2/b^2) 1/EJ dx = [x - x^2/b + 1/3 x^3/b^2]_0^b 1/EJ$$

$$= (b - b + 1/3 b) 1/EJ = 1/3 b/EJ$$

$$L_{DG}^{xx} = \int_0^b (x^2/b^2) 1/EJ dx = [1/3 x^3/b^2]_0^b 1/EJ$$

$$= (1/3 b) 1/EJ = 1/3 b/EJ$$

$$L_{GA}^{xx} = \int_0^b (1/4 - 1/2 x/b + 1/4 x^2/b^2) 1/EJ dx = [1/4 x - 1/4 x^2/b + 1/12 x^3/b^2]_0^b 1/EJ$$

$$= (1/4 b - 1/4 b + 1/12 b) 1/EJ = 1/12 b/EJ$$

$$L_{AG}^{xx} = \int_0^b (1/4 x^2/b^2) 1/EJ dx = [1/12 x^3/b^2]_0^b 1/EJ$$

$$= (1/12 b) 1/EJ = 1/12 b/EJ$$

$$L_{FG}^{xo} = \int_0^b (1/2 x^2/b^2) Fb 1/EJ dx + \int_0^b (1/2 x/b) \theta dx = [1/6 x^3/b^2]_0^b Fb 1/EJ + [1/4 x^2/b]_0^b \theta$$

$$= (1/6 b) Fb 1/EJ + (1/4 b) \theta = 5/12 Fb^2/EJ$$

$$L_{GF}^{xo} = \int_0^b (1/2 - x/b + 1/2 x^2/b^2) Fb 1/EJ dx + \int_0^b (-1/2 + 1/2 x/b) \theta dx$$

$$= [1/2 x - 1/2 x^2/b + 1/6 x^3/b^2]_0^b Fb 1/EJ + [-1/2 x + 1/4 x^2/b]_0^b \theta$$

$$= (1/2 b - 1/2 b + 1/6 b) Fb 1/EJ + (-1/2 b + 1/4 b) \theta = 5/12 Fb^2/EJ$$

$$L_{GD}^{xo} = \int_0^b (x/b - x^2/b^2) Fb 1/EJ dx = [1/2 x^2/b - 1/3 x^3/b^2]_0^b Fb 1/EJ$$

$$= (1/2 b - 1/3 b) Fb 1/EJ = 1/6 Fb^2/EJ$$

$$L_{DG}^{xo} = \int_0^b (x/b - x^2/b^2) Fb 1/EJ dx = [1/2 x^2/b - 1/3 x^3/b^2]_0^b Fb 1/EJ$$

$$= (1/2 b - 1/3 b) Fb 1/EJ = 1/6 Fb^2/EJ$$

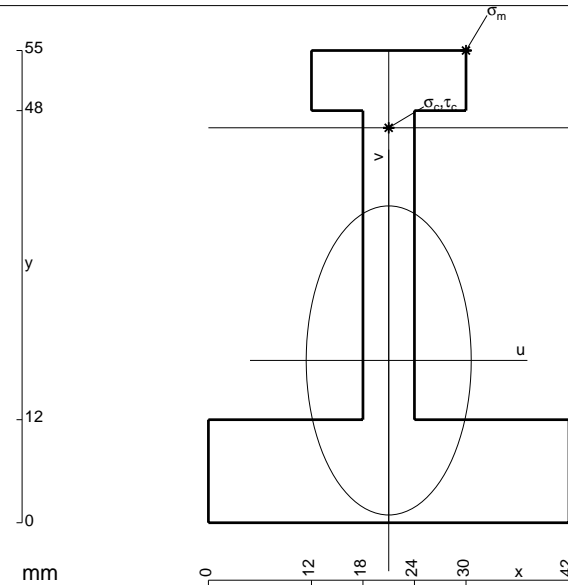

$$A = 846. \text{ mm}^2$$

$$J_u = 274282. \text{ mm}^4$$

$$J_v = 78138. \text{ mm}^4$$

$$y_g = 18.9 \text{ mm}$$

$$T_y = -2310. \text{ N}$$

$$M_x = -1501500. \text{ Nmm}$$

$$x_m = 30. \text{ mm}$$

$$y_m = 55. \text{ mm}$$

$$u_m = 9. \text{ mm}$$

$$v_m = 36.1 \text{ mm}$$

$$\sigma_m = -Mv/J_u = 197.6 \text{ N/mm}^2$$

$$x_c = 21. \text{ mm}$$

$$y_c = 46. \text{ mm}$$

$$v_c = 27.1 \text{ mm}$$

$$\sigma_c = -Mv/J_u = 148.3 \text{ N/mm}^2$$

$$\tau_c = 6.238 \text{ N/mm}^2$$

$$\sigma_q = \sqrt{\sigma^2 + 3\tau^2} = 148.7 \text{ N/mm}^2$$

$$S = 4444. \text{ mm}^3$$

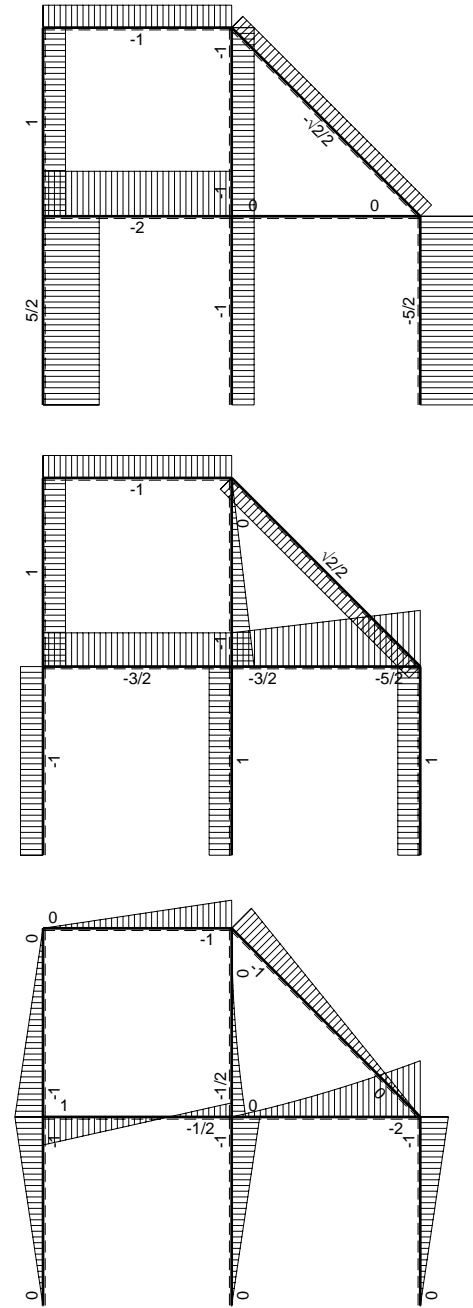
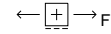
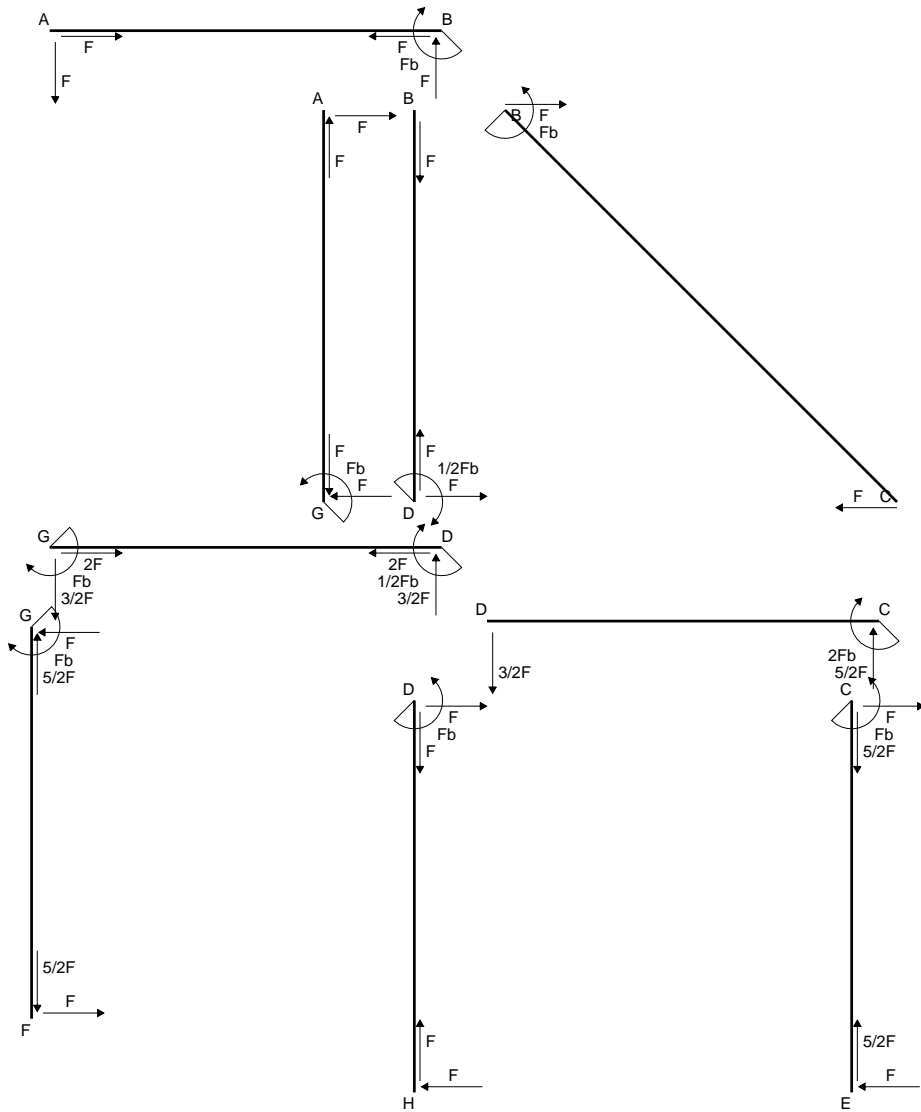

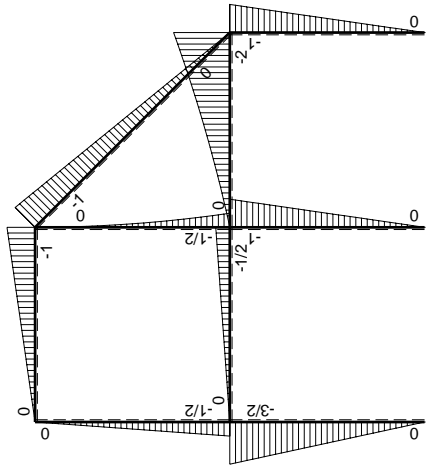
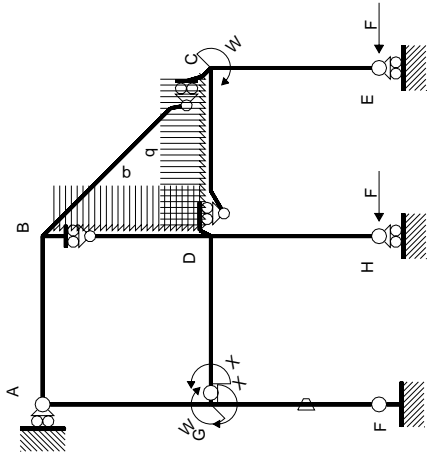

Schema di calcolo iperstatico

M_0 flessione da carichi assegnati

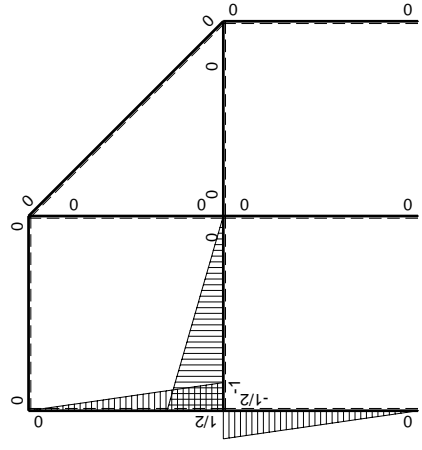

M_x flessione da iperstatica $X=1$

Quadro contributi PLV per iperstatica $X=W_{GD}$

→	$M_x(x)$	$M_o(x)$	θ	$M_x M_o$	$M_x \theta$	$M_x M_x$	$\int M_x(M_o/EJ+\theta)dx$	$\int X M_x M_x/EJ dx$
AB b	0	-Fx	0	0	0	0	0+0	0
BA b	0	Fb-Fx	0	0	0	0	0	0
BC $\sqrt{2}b$	0	-Fb+ $\sqrt{2}/2Fx$	0	0	0	0	0	0
BD b	0	-1/2qx ²	0	0	0	0	0+0	0
DB b	0	1/2Fb-Fx+1/2qx ²	0	0	0	0	0+0	0
DC b	0	-3/2Fx-1/2qx ²	0	0	0	0	0+0	0
CD b	0	2Fb-5/2Fx+1/2qx ²	0	0	0	0	0+0	0
CE b	0	-Fb+Fx	0	0	0	0	0+0	0
EC b	0	Fx	0	0	0	0	0+0	0
FG b	-1/2x/b	-3/2Fx	-Fb/EJ	3/4Fx ² /b	1/2Fx/EJ	1/4x ² /b ²	(1/4+1/4)Fb ² /EJ	1/12Xb/EJ
GF b	1/2-1/2x/b	3/2Fb-3/2Fx	Fb/EJ	3/4Fb-3/2Fx+3/4Fx ² /b	1/2Fb/EJ-1/2Fx/EJ	1/4-1/2x/b+1/4x ² /b ²	(1/4+1/4)Fb ² /EJ	1/12Xb/EJ
GD b	-1+x/b	-1/2Fx	0	1/2Fx-1/2Fx ² /b	0	1-2x/b+x ² /b ²	(1/12+0)Fb ² /EJ	1/3Xb/EJ
DG b	x/b	1/2Fb-1/2Fx	0	1/2Fx-1/2Fx ² /b	0	x ² /b ²	(1/12+0)Fb ² /EJ	1/3Xb/EJ
DH b	0	-Fb+Fx	0	0	0	0	0+0	0
HD b	0	Fx	0	0	0	0	0+0	0
GA b	1/2-1/2x/b	-1/2Fb+1/2Fx	0	-1/4Fb+1/2Fx-1/4Fx ² /b	0	1/4-1/2x/b+1/4x ² /b ²	(-1/12+0)Fb ² /EJ	1/12Xb/EJ
AG b	-1/2x/b	1/2Fx	0	-1/4Fx ² /b	0	1/4x ² /b ²	(-1/12+0)Fb ² /EJ	1/12Xb/EJ
	totali						1/2Fb ² /EJ	1/2Xb/EJ
	iperstatica $X=W_{GD}$						-Fb	

Sviluppi di calcolo iperstatica

$$L_{FG}^{xx} = \int_0^b (1/4 x^2/b^2) 1/EJ dx = [1/12 x^3/b^2]_0^b 1/EJ$$

$$= (1/12 b) 1/EJ = 1/12 b/EJ$$

$$L_{GF}^{xx} = \int_0^b (1/4 - 1/2 x/b + 1/4 x^2/b^2) 1/EJ dx = [1/4 x - 1/4 x^2/b + 1/12 x^3/b^2]_0^b 1/EJ$$

$$= (1/4 b - 1/4 b + 1/12 b) 1/EJ = 1/12 b/EJ$$

$$L_{GD}^{xx} = \int_0^b (1 - 2 x/b + x^2/b^2) 1/EJ dx = [x - x^2/b + 1/3 x^3/b^2]_0^b 1/EJ$$

$$= (b - b + 1/3 b) 1/EJ = 1/3 b/EJ$$

$$L_{DG}^{xx} = \int_0^b (x^2/b^2) 1/EJ dx = [1/3 x^3/b^2]_0^b 1/EJ$$

$$= (1/3 b) 1/EJ = 1/3 b/EJ$$

$$L_{GA}^{xx} = \int_0^b (1/4 - 1/2 x/b + 1/4 x^2/b^2) 1/EJ dx = [1/4 x - 1/4 x^2/b + 1/12 x^3/b^2]_0^b 1/EJ$$

$$= (1/4 b - 1/4 b + 1/12 b) 1/EJ = 1/12 b/EJ$$

$$L_{AG}^{xx} = \int_0^b (1/4 x^2/b^2) 1/EJ dx = [1/12 x^3/b^2]_0^b 1/EJ$$

$$= (1/12 b) 1/EJ = 1/12 b/EJ$$

$$L_{FG}^{xo} = \int_0^b (3/4 x^2/b^2) Fb 1/EJ dx + \int_0^b (1/2 x/b) \theta dx = [1/4 x^3/b^2]_0^b Fb 1/EJ + [1/4 x^2/b]_0^b \theta$$

$$= (1/4 b) Fb 1/EJ + (1/4 b) \theta = 1/2 Fb^2/EJ$$

$$L_{GF}^{xo} = \int_0^b (3/4 - 3/2 x/b + 3/4 x^2/b^2) Fb 1/EJ dx + \int_0^b (-1/2 + 1/2 x/b) \theta dx$$

$$= [3/4 x - 3/4 x^2/b + 1/4 x^3/b^2]_0^b Fb 1/EJ + [-1/2 x + 1/4 x^2/b]_0^b \theta$$

$$= (3/4 b - 3/4 b + 1/4 b) Fb 1/EJ + (-1/2 b + 1/4 b) \theta = 1/2 Fb^2/EJ$$

$$L_{GD}^{xo} = \int_0^b (1/2 x/b - 1/2 x^2/b^2) Fb 1/EJ dx = [1/4 x^2/b - 1/6 x^3/b^2]_0^b Fb 1/EJ$$

$$= (1/4 b - 1/6 b) Fb 1/EJ = 1/12 Fb^2/EJ$$

$$L_{DG}^{xo} = \int_0^b (1/2 x/b - 1/2 x^2/b^2) Fb 1/EJ dx = [1/4 x^2/b - 1/6 x^3/b^2]_0^b Fb 1/EJ$$

$$= (1/4 b - 1/6 b) Fb 1/EJ = 1/12 Fb^2/EJ$$

$$L_{GA}^{xo} = \int_0^b (-1/4 + 1/2 x/b - 1/4 x^2/b^2) Fb 1/EJ dx = [-1/4 x + 1/4 x^2/b - 1/12 x^3/b^2]_0^b Fb 1/EJ$$

$$= (-1/4 b + 1/4 b - 1/12 b) Fb 1/EJ = -1/12 Fb^2/EJ$$

$$L_{AG}^{xo} = \int_0^b (-1/4 x^2/b^2) Fb 1/EJ dx = [-1/12 x^3/b^2]_0^b Fb 1/EJ$$

$$= (-1/12 b) Fb 1/EJ = -1/12 Fb^2/EJ$$

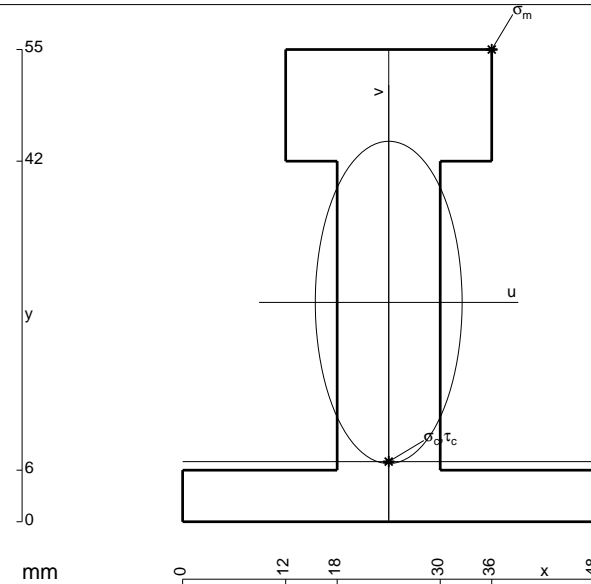

- A = 1032. mm²
- J_u = 363732. mm⁴
- J_v = 75456. mm⁴
- y_g = 25.55 mm
- T_y = -3900. N
- M_x = -2589600. Nmm
- x_m = 36. mm
- y_m = 55. mm
- u_m = 12. mm
- v_m = 29.45 mm
- σ_m = -Mv/J_u = 209.7 N/mm²
- x_c = 24. mm
- y_c = 7. mm
- v_c = -18.55 mm
- σ_c = -Mv/J_u = -132. N/mm²
- τ_c = 6.006 N/mm²
- σ_q = √σ²+3τ² = 132.5 N/mm²
- S = 6722. mm³

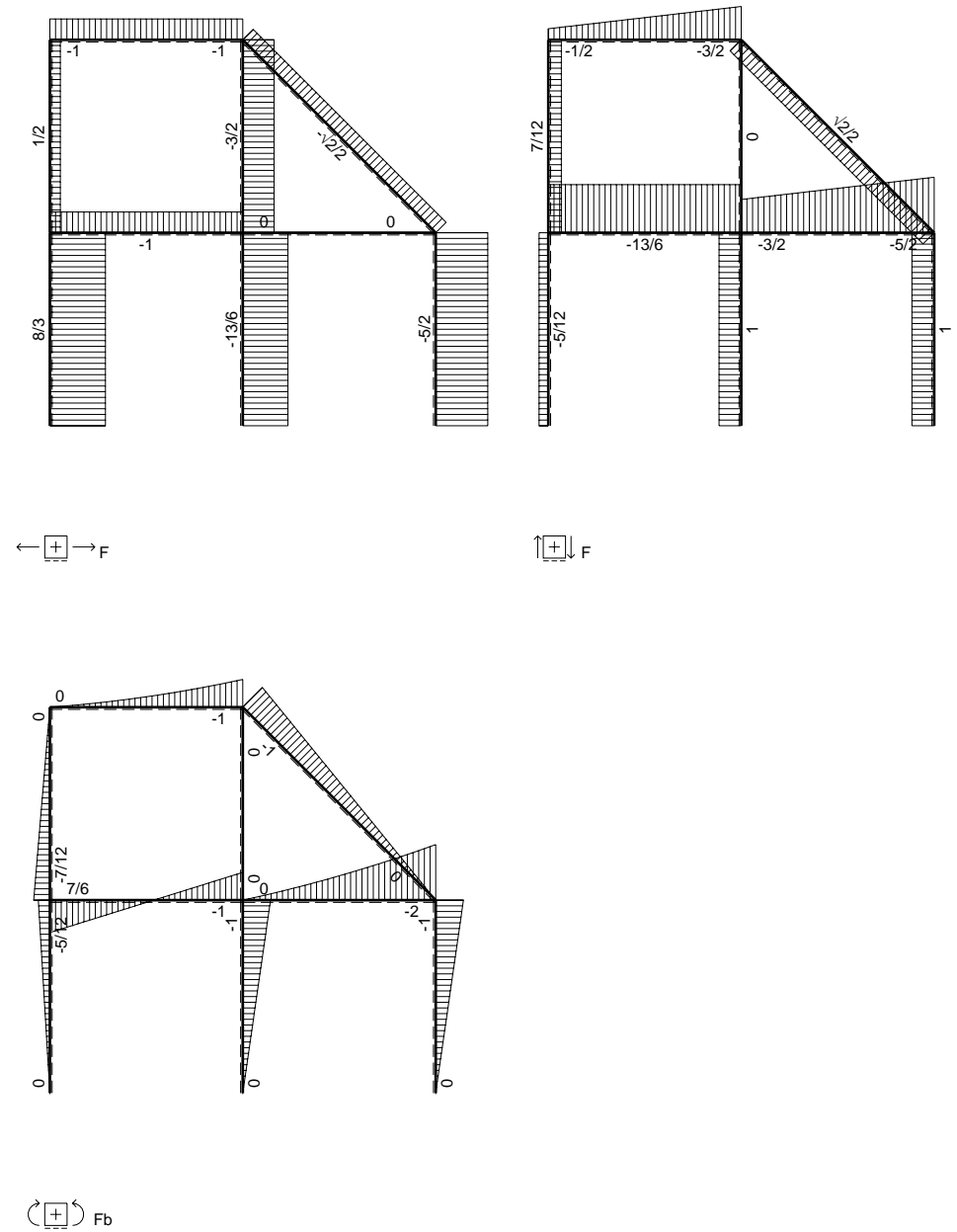
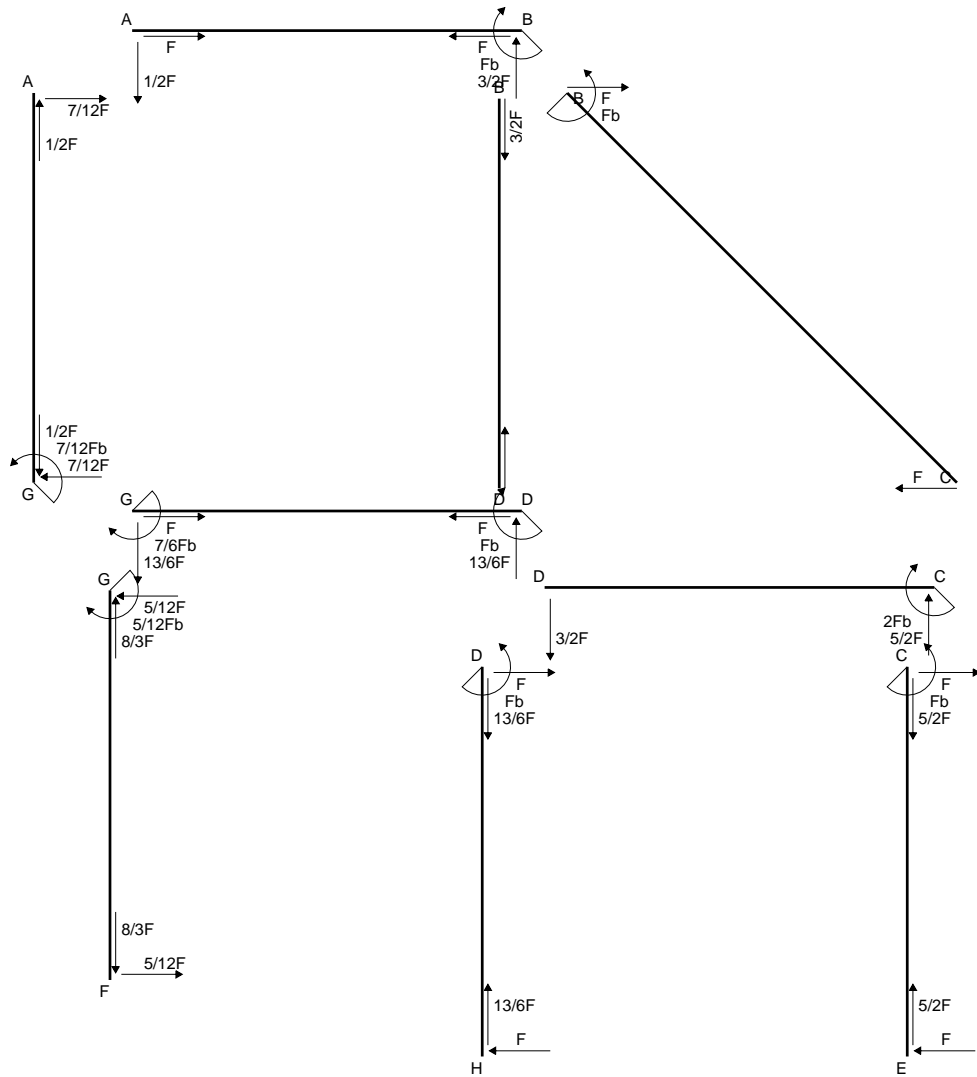

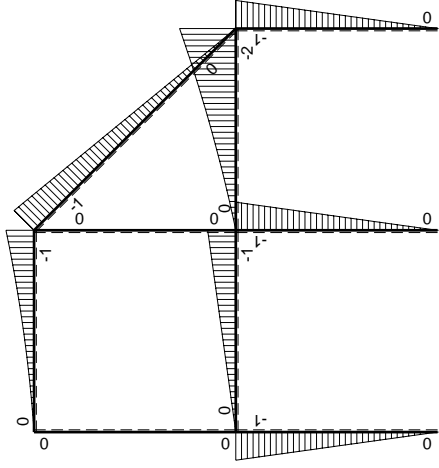
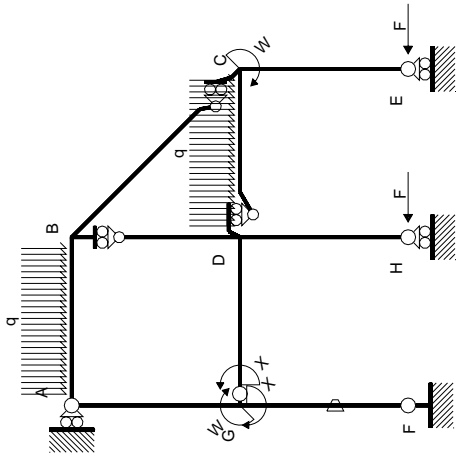

Schema di calcolo iperstatico

M_0 flessione da carichi assegnati

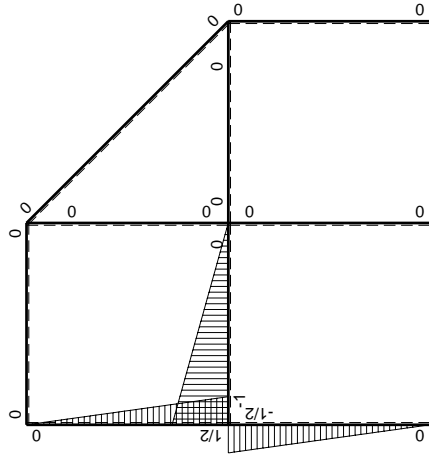

M_x flessione da iperstatica $X=1$

Quadro contributi PLV per iperstatica $X=W_{GD}$

→	$M_x(x)$	$M_o(x)$	θ	$M_x M_o$	$M_x \theta$	$M_x M_x$	$\int M_x(M_o/EJ+\theta)dx$	$\int X M_x M_x/EJ dx$
AB b	0	$-1/2Fx-1/2qx^2$	0	0	0	0	0+0	0
BA b	0	$Fb-3/2Fx+1/2qx^2$	0	0	0	0	0	0
BC $\sqrt{2}b$	0	$-Fb+\sqrt{2}/2Fx$	0	0	0	0	0	0
BD b	0	0	0	0	0	0	0+0	0
DB b	0	0	0	0	0	0	0	0
DC b	0	$-3/2Fx-1/2qx^2$	0	0	0	0	0+0	0
CD b	0	$2Fb-5/2Fx+1/2qx^2$	0	0	0	0	0	0
CE b	0	$-Fb+Fx$	0	0	0	0	0+0	0
EC b	0	Fx	0	0	0	0	0	0
FG b	$-1/2x/b$	$-Fx$	$-Fb/EJ$	$1/2Fx^2/b$	$1/2Fx/EJ$	$1/4x^2/b^2$	$(1/6+1/4)Fb^2/EJ$	$1/12Xb/EJ$
GF b	$1/2-1/2x/b$	$Fb-Fx$	Fb/EJ	$1/2Fb-Fx+1/2Fx^2/b$	$1/2Fb/EJ-1/2Fx/EJ$	$1/4-1/2x/b+1/4x^2/b^2$		
GD b	$-1+x/b$	$-Fx$	0	$Fx-Fx^2/b$	0	$1-2x/b+x^2/b^2$	$(1/6+0)Fb^2/EJ$	$1/3Xb/EJ$
DG b	x/b	$Fb-Fx$	0	$Fx-Fx^2/b$	0	x^2/b^2		
DH b	0	$-Fb+Fx$	0	0	0	0	0+0	0
HD b	0	Fx	0	0	0	0	0	0
GA b	$1/2-1/2x/b$	0	0	0	0	$1/4-1/2x/b+1/4x^2/b^2$	0+0	$1/12Xb/EJ$
AG b	$-1/2x/b$	0	0	0	0	$1/4x^2/b^2$		
	totali						$7/12Fb^2/EJ$	$1/2Xb/EJ$
	iperstatica $X=W_{GD}$						$-7/6Fb$	

Sviluppi di calcolo iperstatica

$$L_{FG}^{xx} = \int_0^b (1/4 x^2/b^2) 1/EJ dx = [1/12 x^3/b^2]_0^b 1/EJ$$

$$= (1/12 b) 1/EJ = 1/12 b/EJ$$

$$L_{GF}^{xx} = \int_0^b (1/4 - 1/2 x/b + 1/4 x^2/b^2) 1/EJ dx = [1/4 x - 1/4 x^2/b + 1/12 x^3/b^2]_0^b 1/EJ$$

$$= (1/4 b - 1/4 b + 1/12 b) 1/EJ = 1/12 b/EJ$$

$$L_{GD}^{xx} = \int_0^b (1 - 2 x/b + x^2/b^2) 1/EJ dx = [x - x^2/b + 1/3 x^3/b^2]_0^b 1/EJ$$

$$= (b - b + 1/3 b) 1/EJ = 1/3 b/EJ$$

$$L_{DG}^{xx} = \int_0^b (x^2/b^2) 1/EJ dx = [1/3 x^3/b^2]_0^b 1/EJ$$

$$= (1/3 b) 1/EJ = 1/3 b/EJ$$

$$L_{GA}^{xx} = \int_0^b (1/4 - 1/2 x/b + 1/4 x^2/b^2) 1/EJ dx = [1/4 x - 1/4 x^2/b + 1/12 x^3/b^2]_0^b 1/EJ$$

$$= (1/4 b - 1/4 b + 1/12 b) 1/EJ = 1/12 b/EJ$$

$$L_{AG}^{xx} = \int_0^b (1/4 x^2/b^2) 1/EJ dx = [1/12 x^3/b^2]_0^b 1/EJ$$

$$= (1/12 b) 1/EJ = 1/12 b/EJ$$

$$L_{FG}^{xo} = \int_0^b (1/2 x^2/b^2) Fb 1/EJ dx + \int_0^b (1/2 x/b) \theta dx = [1/6 x^3/b^2]_0^b Fb 1/EJ + [1/4 x^2/b]_0^b \theta$$

$$= (1/6 b) Fb 1/EJ + (1/4 b) \theta = 5/12 Fb^2/EJ$$

$$L_{GF}^{xo} = \int_0^b (1/2 - x/b + 1/2 x^2/b^2) Fb 1/EJ dx + \int_0^b (-1/2 + 1/2 x/b) \theta dx$$

$$= [1/2 x - 1/2 x^2/b + 1/6 x^3/b^2]_0^b Fb 1/EJ + [-1/2 x + 1/4 x^2/b]_0^b \theta$$

$$= (1/2 b - 1/2 b + 1/6 b) Fb 1/EJ + (-1/2 b + 1/4 b) \theta = 5/12 Fb^2/EJ$$

$$L_{GD}^{xo} = \int_0^b (x/b - x^2/b^2) Fb 1/EJ dx = [1/2 x^2/b - 1/3 x^3/b^2]_0^b Fb 1/EJ$$

$$= (1/2 b - 1/3 b) Fb 1/EJ = 1/6 Fb^2/EJ$$

$$L_{DG}^{xo} = \int_0^b (x/b - x^2/b^2) Fb 1/EJ dx = [1/2 x^2/b - 1/3 x^3/b^2]_0^b Fb 1/EJ$$

$$= (1/2 b - 1/3 b) Fb 1/EJ = 1/6 Fb^2/EJ$$

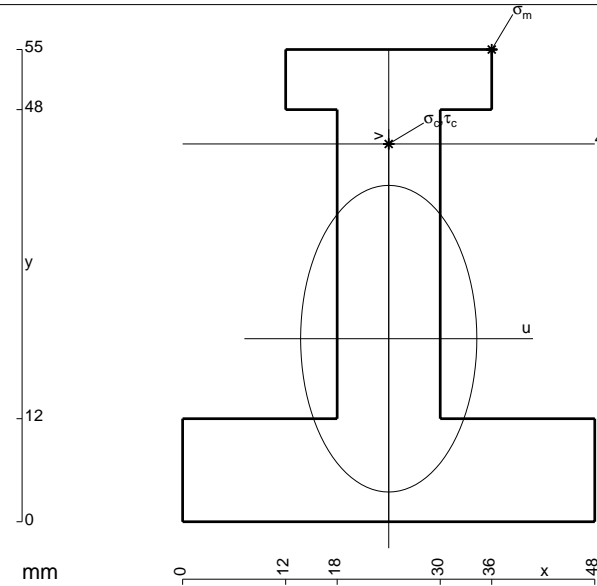

- A = 1176. mm²
- J_u = 375010. mm⁴
- J_v = 123840. mm⁴
- y_g = 21.32 mm
- T_y = -3475. N
- M_x = -2446400. Nmm
- x_m = 36. mm
- y_m = 55. mm
- u_m = 12. mm
- v_m = 33.68 mm
- σ_m = -M_v/J_u = 219.7 N/mm²
- x_c = 24. mm
- y_c = 44. mm
- v_c = 22.68 mm
- σ_c = -M_v/J_u = 148. N/mm²
- τ_c = 4.831 N/mm²
- σ_q = √σ²+3τ² = 148.2 N/mm²
- S = 6256. mm³

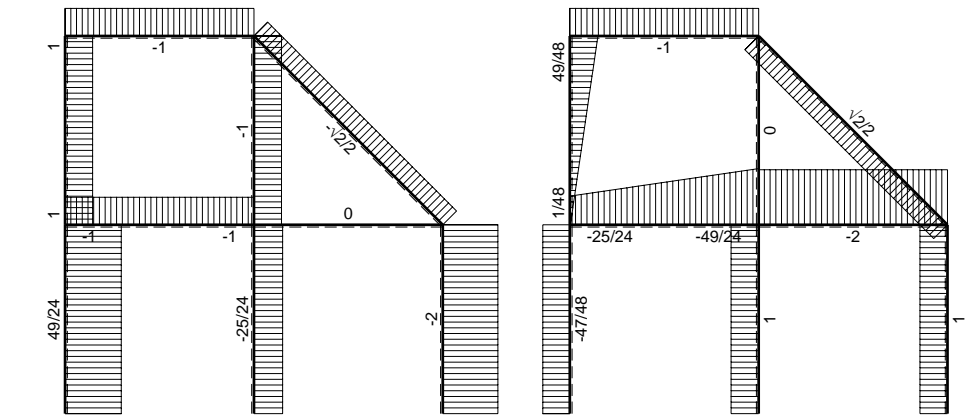
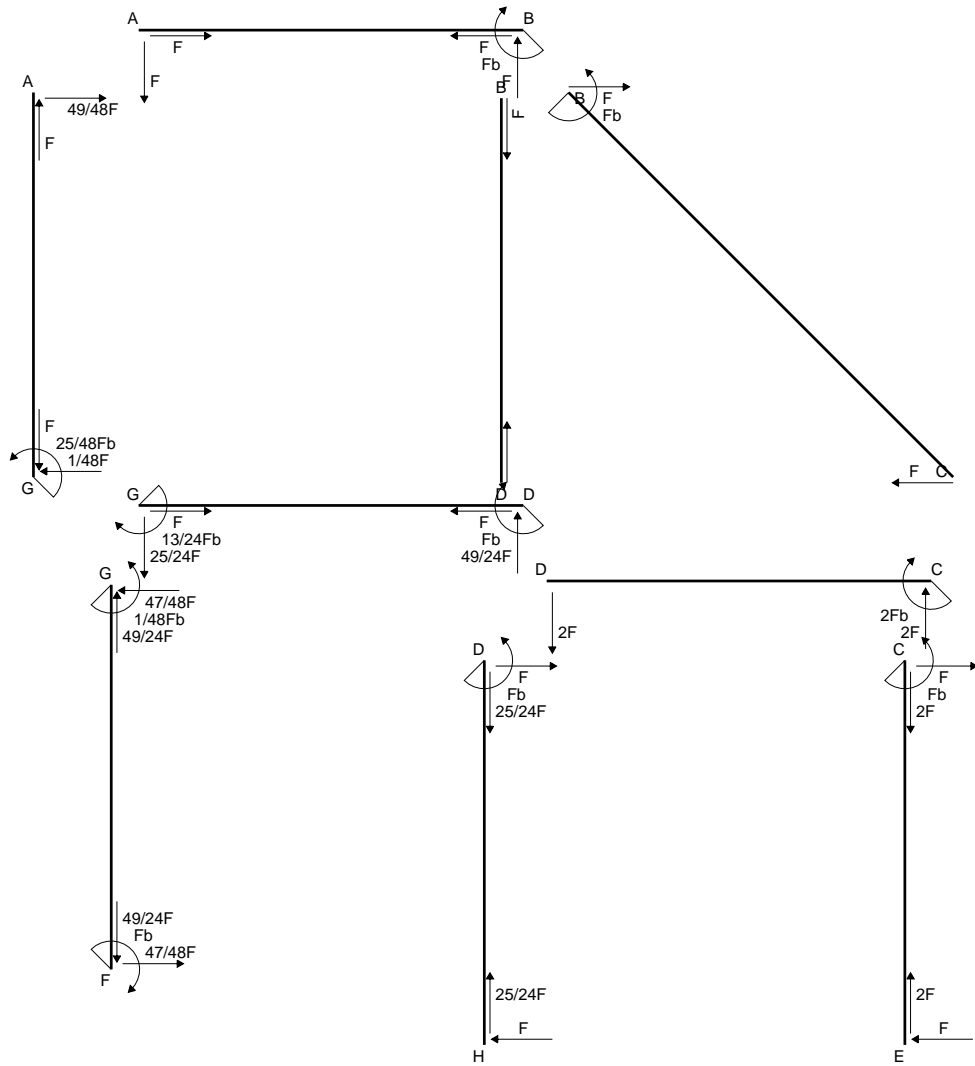

← ⊕ → F

↑ ⊕ ↓ F

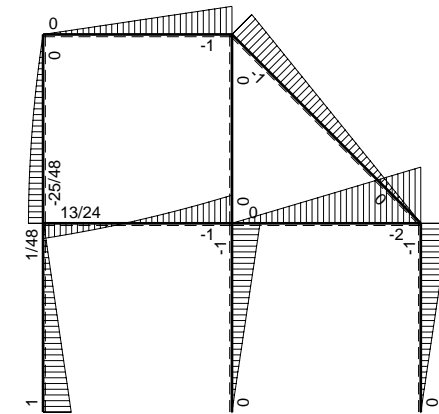

⊕ ⊖ F_b

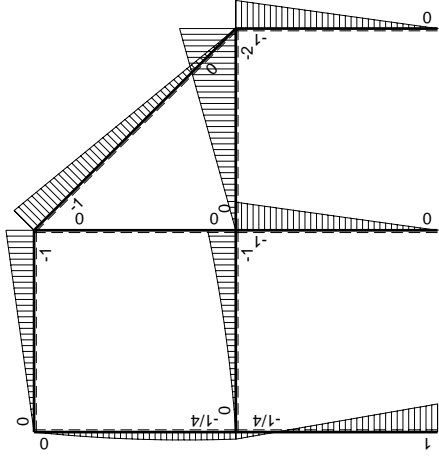
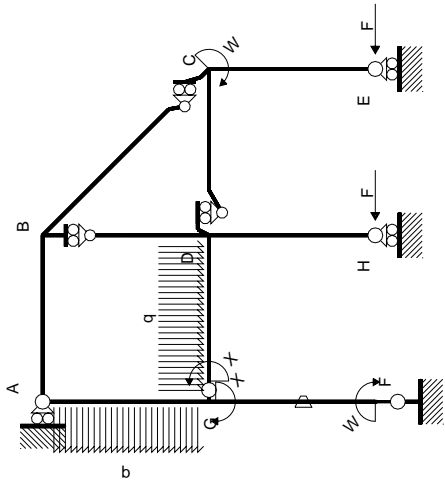

Schema di calcolo iperstatico

M_0 flessione da carichi assegnati

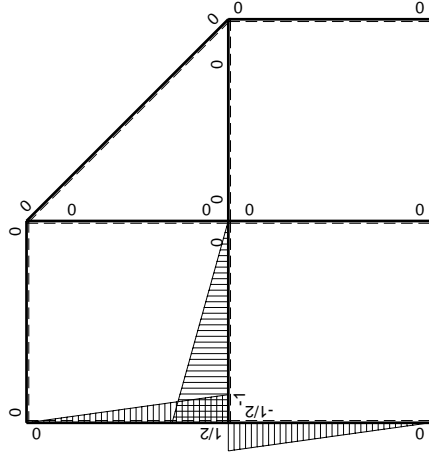

M_x flessione da iperstatica $X=1$

Quadro contributi PLV per iperstatica $X=W_{GD}$

→	$M_x(x)$	$M_o(x)$	θ	$M_x M_o$	$M_x \theta$	$M_x M_x$	$\int M_x(M_o/EJ+\theta)dx$	$\int X M_x M_x/EJ dx$	
AB b	0	-Fx	0	0	0	0	0+0	0	
BA b	0	Fb-Fx	0	0	0	0	0	0	
BC $\sqrt{2}b$	0	-Fb+ $\sqrt{2}/2Fx$	0	0	0	0	0	0	
BD b	0	0	0	0	0	0	0+0	0	
DB b	0	0	0	0	0	0	0	0	
DC b	0	-2Fx	0	0	0	0	0+0	0	
CD b	0	2Fb-2Fx	0	0	0	0	0	0	
CE b	0	-Fb+Fx	0	0	0	0	0+0	0	
EC b	0	Fx	0	0	0	0	0	0	
FG b	-1/2x/b	Fb-5/4Fx	-Fb/EJ	-1/2Fx+5/8Fx ² /b	1/2Fx/EJ	1/4x ² /b ²	(-1/24+1/4)Fb ² /EJ	1/12Xb/EJ	
GF b	1/2-1/2x/b	1/4Fb-5/4Fx	Fb/EJ	1/8Fb-3/4Fx+5/8Fx ² /b	1/2Fb/EJ-1/2Fx/EJ	1/4-1/2x/b+1/4x ² /b ²			
GD b	-1+x/b	-1/2Fx-1/2qx ²	0	1/2Fx-1/2qx ³ /b	0	1-2x/b+x ² /b ²	(1/8+0)Fb ² /EJ	1/3Xb/EJ	
DG b	x/b	Fb-3/2Fx+1/2qx ²	0	Fx-3/2Fx ² /b+1/2qx ³ /b	0	x ² /b ²			
DH b	0	-Fb+Fx	0	0	0	0	0+0	0	
HD b	0	Fx	0	0	0	0	0	0	
GA b	1/2-1/2x/b	-1/4Fb-1/4Fx+1/2qx ²	0	-1/8Fb+3/8Fx ² /b-1/4qx ³ /b	0	1/4-1/2x/b+1/4x ² /b ²	(-1/16+0)Fb ² /EJ	1/12Xb/EJ	
AG b	-1/2x/b	3/4Fx-1/2qx ²	0	-3/8Fx ² /b+1/4qx ³ /b	0	1/4x ² /b ²			
	totali							13/48Fb ² /EJ	1/2Xb/EJ
	iperstatica $X=W_{GD}$							-13/24Fb	

Sviluppi di calcolo iperstatica

$$L_{FG}^{xx} = \int_0^b (1/4 x^2/b^2) 1/EJ dx = [1/12 x^3/b^2]_0^b 1/EJ$$

$$= (1/12 b) 1/EJ = 1/12 b/EJ$$

$$L_{GF}^{xx} = \int_0^b (1/4 - 1/2 x/b + 1/4 x^2/b^2) 1/EJ dx = [1/4 x - 1/4 x^2/b + 1/12 x^3/b^2]_0^b 1/EJ$$

$$= (1/4 b - 1/4 b + 1/12 b) 1/EJ = 1/12 b/EJ$$

$$L_{GD}^{xx} = \int_0^b (1 - 2 x/b + x^2/b^2) 1/EJ dx = [x - x^2/b + 1/3 x^3/b^2]_0^b 1/EJ$$

$$= (b - b + 1/3 b) 1/EJ = 1/3 b/EJ$$

$$L_{DG}^{xx} = \int_0^b (x^2/b^2) 1/EJ dx = [1/3 x^3/b^2]_0^b 1/EJ$$

$$= (1/3 b) 1/EJ = 1/3 b/EJ$$

$$L_{GA}^{xx} = \int_0^b (1/4 - 1/2 x/b + 1/4 x^2/b^2) 1/EJ dx = [1/4 x - 1/4 x^2/b + 1/12 x^3/b^2]_0^b 1/EJ$$

$$= (1/4 b - 1/4 b + 1/12 b) 1/EJ = 1/12 b/EJ$$

$$L_{AG}^{xx} = \int_0^b (1/4 x^2/b^2) 1/EJ dx = [1/12 x^3/b^2]_0^b 1/EJ$$

$$= (1/12 b) 1/EJ = 1/12 b/EJ$$

$$L_{FG}^{xo} = \int_0^b (-1/2 x/b + 5/8 x^2/b^2) Fb 1/EJ dx + \int_0^b (1/2 x/b) \theta dx$$

$$= [-1/4 x^2/b + 5/24 x^3/b^2]_0^b Fb 1/EJ + [1/4 x^2/b]_0^b \theta$$

$$= (-1/4 b + 5/24 b) Fb 1/EJ + (1/4 b) \theta = 5/24 Fb^2/EJ$$

$$L_{GF}^{xo} = \int_0^b (1/8 - 3/4 x/b + 5/8 x^2/b^2) Fb 1/EJ dx + \int_0^b (-1/2 + 1/2 x/b) \theta dx$$

$$= [1/8 x - 3/8 x^2/b + 5/24 x^3/b^2]_0^b Fb 1/EJ + [-1/2 x + 1/4 x^2/b]_0^b \theta$$

$$= (1/8 b - 3/8 b + 5/24 b) Fb 1/EJ + (-1/2 b + 1/4 b) \theta = 5/24 Fb^2/EJ$$

$$L_{GD}^{xo} = \int_0^b (1/2 x/b - 1/2 x^3/b^3) Fb 1/EJ dx = [1/4 x^2/b - 1/8 x^4/b^3]_0^b Fb 1/EJ$$

$$= (1/4 b - 1/8 b) Fb 1/EJ = 1/8 Fb^2/EJ$$

$$L_{DG}^{xo} = \int_0^b (x/b - 3/2 x^2/b^2 + 1/2 x^3/b^3) Fb 1/EJ dx = [1/2 x^2/b - 1/2 x^3/b^2 + 1/8 x^4/b^3]_0^b Fb 1/EJ$$

$$= (1/2 b - 1/2 b + 1/8 b) Fb 1/EJ = 1/8 Fb^2/EJ$$

$$L_{GA}^{xo} = \int_0^b (-1/8 + 3/8 x^2/b^2 - 1/4 x^3/b^3) Fb 1/EJ dx = [-1/8 x + 1/8 x^3/b^2 - 1/16 x^4/b^3]_0^b Fb 1/EJ$$

$$= (-1/8 b + 1/8 b - 1/16 b) Fb 1/EJ = -1/16 Fb^2/EJ$$

$$L_{AG}^{xo} = \int_0^b (-3/8 x^2/b^2 + 1/4 x^3/b^3) Fb 1/EJ dx = [-1/8 x^3/b^2 + 1/16 x^4/b^3]_0^b Fb 1/EJ$$

$$= (-1/8 b + 1/16 b) Fb 1/EJ = -1/16 Fb^2/EJ$$

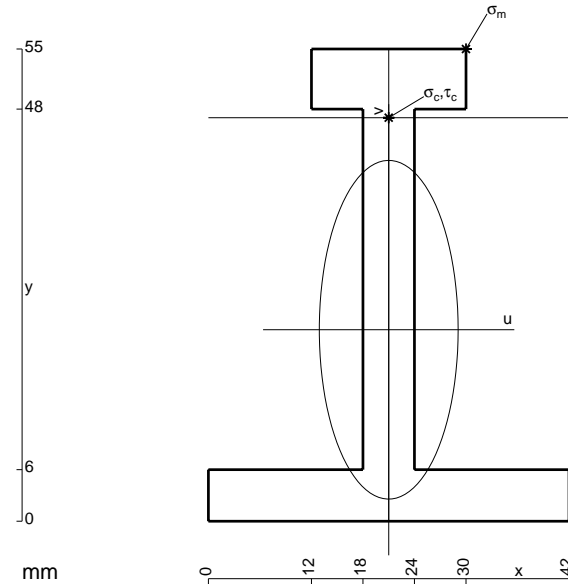

- A = 630. mm²
- J_u = 245181. mm⁴
- J_v = 41202. mm⁴
- y_g = 22.3 mm
- T_y = -1840. N
- M_x = -1711200. Nmm
- x_m = 30. mm
- y_m = 55. mm
- u_m = 9. mm
- v_m = 32.7 mm
- σ_m = -Mv/J_u = 228.2 N/mm²
- x_c = 21. mm
- y_c = 47. mm
- v_c = 24.7 mm
- σ_c = -Mv/J_u = 172.4 N/mm²
- τ_c = 4.791 N/mm²
- σ_o = √σ²+3τ² = 172.6 N/mm²
- S = 3830. mm³

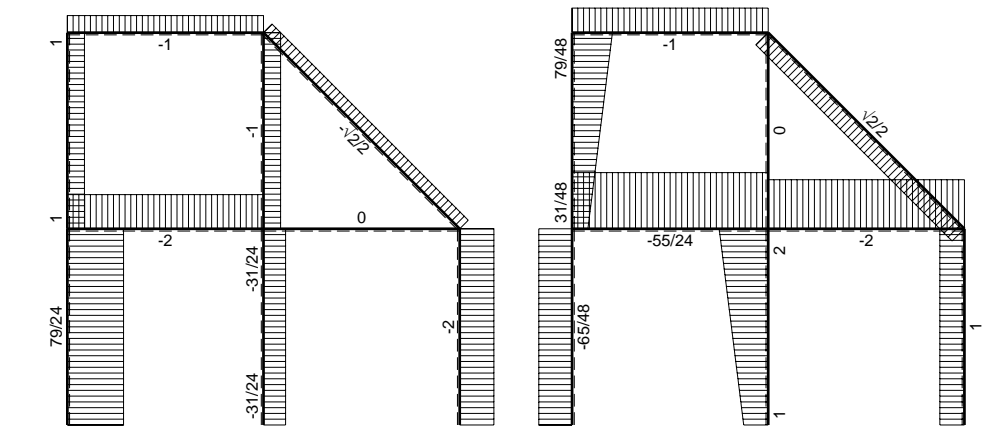
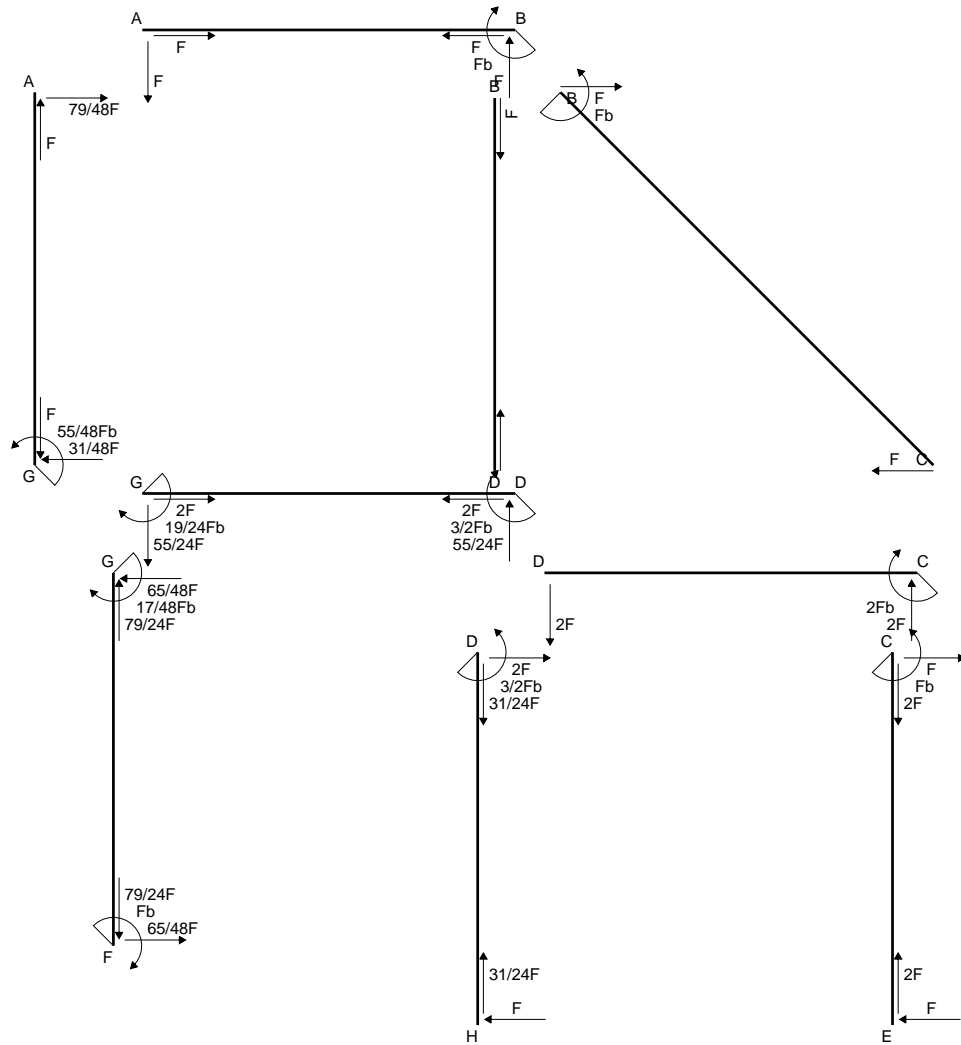

← ⊕ → F

↑ ⊕ ↓ F

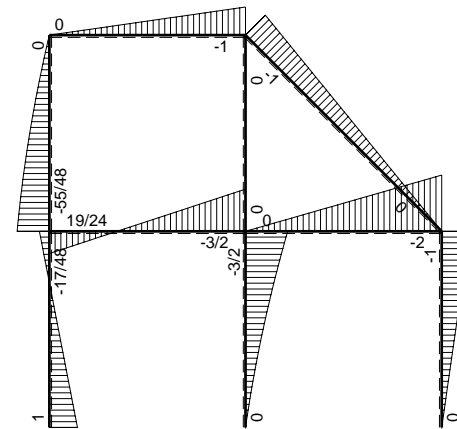

⊕ ⊖ F_b

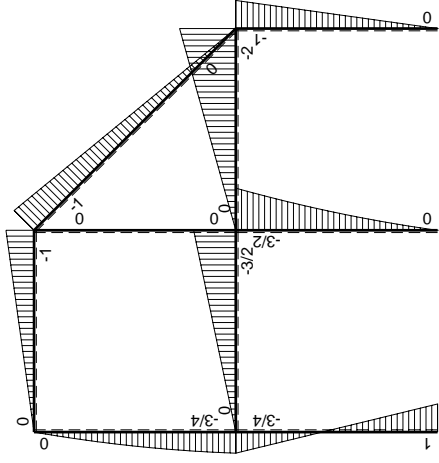
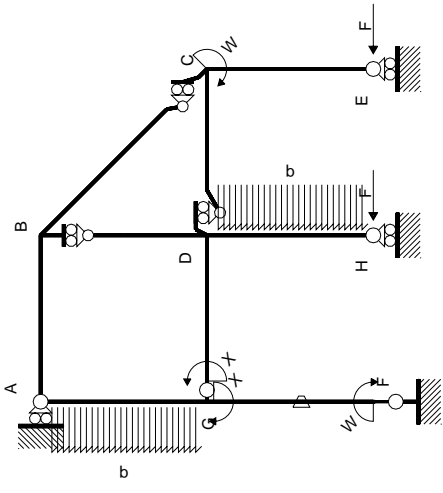

Schema di calcolo iperstatico

M_0 , flessione da carichi assegnati

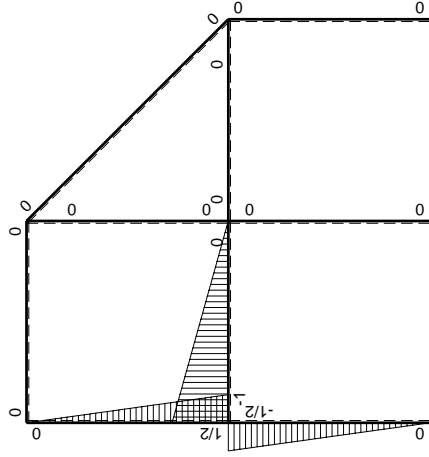

M_x , flessione da iperstatica $X=1$

Quadro contributi PLV per iperstatica $X=W_{GD}$

→	$M_x(x)$	$M_o(x)$	θ	$M_x M_o$	$M_x \theta$	$M_x M_x$	$\int M_x(M_o/EJ+\theta)dx$	$\int X M_x M_x/EJ dx$
AB b	0	-Fx	0	0	0	0	0+0	0
BA b	0	Fb-Fx	0	0	0	0	0	0
BC $\sqrt{2}b$	0	-Fb+ $\sqrt{2}/2Fx$	0	0	0	0	0	0
BD b	0	0	0	0	0	0	0+0	0
DB b	0	0	0	0	0	0	0	0
DC b	0	-2Fx	0	0	0	0	0+0	0
CD b	0	2Fb-2Fx	0	0	0	0	0	0
CE b	0	-Fb+Fx	0	0	0	0	0+0	0
EC b	0	Fx	0	0	0	0	0	0
FG b	-1/2x/b	Fb-7/4Fx	-Fb/EJ	-1/2Fx+7/8Fx ² /b	1/2Fx/EJ	1/4x ² /b ²	(1/24+1/4)Fb ² /EJ	1/12Xb/EJ
GF b	1/2-1/2x/b	3/4Fb-7/4Fx	Fb/EJ	3/8Fb-5/4Fx+7/8Fx ² /b	1/2Fb/EJ-1/2Fx/EJ	1/4-1/2x/b+1/4x ² /b ²		
GD b	-1+x/b	-3/2Fx	0	3/2Fx-3/2Fx ² /b	0	1-2x/b+x ² /b ²	(1/4+0)Fb ² /EJ	1/3Xb/EJ
DG b	x/b	3/2Fb-3/2Fx	0	3/2Fx-3/2Fx ² /b	0	x ² /b ²		
DH b	0	-3/2Fb+2Fx-1/2qx ²	0	0	0	0	0+0	0
HD b	0	Fx+1/2qx ²	0	0	0	0		
GA b	1/2-1/2x/b	-3/4Fb+1/4Fx+1/2qx ²	0	-3/8Fb+1/2Fx+1/8Fx ² /b-1/4qx ³ /b	0	1/4-1/2x/b+1/4x ² /b ²	(-7/48+0)Fb ² /EJ	1/12Xb/EJ
AG b	-1/2x/b	5/4Fx-1/2qx ²	0	-5/8Fx ² /b+1/4qx ³ /b	0	1/4x ² /b ²		
	totali						19/48Fb ² /EJ	1/2Xb/EJ
	iperstatica $X=W_{GD}$						-19/24Fb	

Sviluppi di calcolo iperstatica

$$L_{FG}^{xx} = \int_0^b (1/4 x^2/b^2) 1/EJ dx = [1/12 x^3/b^2]_0^b 1/EJ$$

$$= (1/12 b) 1/EJ = 1/12 b/EJ$$

$$L_{GF}^{xx} = \int_0^b (1/4 - 1/2 x/b + 1/4 x^2/b^2) 1/EJ dx = [1/4 x - 1/4 x^2/b + 1/12 x^3/b^2]_0^b 1/EJ$$

$$= (1/4 b - 1/4 b + 1/12 b) 1/EJ = 1/12 b/EJ$$

$$L_{GD}^{xx} = \int_0^b (1 - 2 x/b + x^2/b^2) 1/EJ dx = [x - x^2/b + 1/3 x^3/b^2]_0^b 1/EJ$$

$$= (b - b + 1/3 b) 1/EJ = 1/3 b/EJ$$

$$L_{DG}^{xx} = \int_0^b (x^2/b^2) 1/EJ dx = [1/3 x^3/b^2]_0^b 1/EJ$$

$$= (1/3 b) 1/EJ = 1/3 b/EJ$$

$$L_{GA}^{xx} = \int_0^b (1/4 - 1/2 x/b + 1/4 x^2/b^2) 1/EJ dx = [1/4 x - 1/4 x^2/b + 1/12 x^3/b^2]_0^b 1/EJ$$

$$= (1/4 b - 1/4 b + 1/12 b) 1/EJ = 1/12 b/EJ$$

$$L_{AG}^{xx} = \int_0^b (1/4 x^2/b^2) 1/EJ dx = [1/12 x^3/b^2]_0^b 1/EJ$$

$$= (1/12 b) 1/EJ = 1/12 b/EJ$$

$$L_{FG}^{x_0} = \int_0^b (-1/2 x/b + 7/8 x^2/b^2) Fb 1/EJ dx + \int_0^b (1/2 x/b) \theta dx$$

$$= [-1/4 x^2/b + 7/24 x^3/b^2]_0^b Fb 1/EJ + [1/4 x^2/b]_0^b \theta$$

$$= (-1/4 b + 7/24 b) Fb 1/EJ + (1/4 b) \theta = 7/24 Fb^2/EJ$$

$$L_{GF}^{x_0} = \int_0^b (3/8 - 5/4 x/b + 7/8 x^2/b^2) Fb 1/EJ dx + \int_0^b (-1/2 + 1/2 x/b) \theta dx$$

$$= [3/8 x - 5/8 x^2/b + 7/24 x^3/b^2]_0^b Fb 1/EJ + [-1/2 x + 1/4 x^2/b]_0^b \theta$$

$$= (3/8 b - 5/8 b + 7/24 b) Fb 1/EJ + (-1/2 b + 1/4 b) \theta = 7/24 Fb^2/EJ$$

$$L_{GD}^{x_0} = \int_0^b (3/2 x/b - 3/2 x^2/b^2) Fb 1/EJ dx = [3/4 x^2/b - 1/2 x^3/b^2]_0^b Fb 1/EJ$$

$$= (3/4 b - 1/2 b) Fb 1/EJ = 1/4 Fb^2/EJ$$

$$L_{DG}^{x_0} = \int_0^b (3/2 x/b - 3/2 x^2/b^2) Fb 1/EJ dx = [3/4 x^2/b - 1/2 x^3/b^2]_0^b Fb 1/EJ$$

$$= (3/4 b - 1/2 b) Fb 1/EJ = 1/4 Fb^2/EJ$$

$$L_{GA}^{x_0} = \int_0^b (-3/8 + 1/2 x/b + 1/8 x^2/b^2 - 1/4 x^3/b^3) Fb 1/EJ dx$$

$$= [-3/8 x + 1/4 x^2/b + 1/24 x^3/b^2 - 1/16 x^4/b^3]_0^b Fb 1/EJ$$

$$= (-3/8 b + 1/4 b + 1/24 b - 1/16 b) Fb 1/EJ = -7/48 Fb^2/EJ$$

$$L_{AG}^{x_0} = \int_0^b (-5/8 x^2/b^2 + 1/4 x^3/b^3) Fb 1/EJ dx = [-5/24 x^3/b^2 + 1/16 x^4/b^3]_0^b Fb 1/EJ$$

$$= (-5/24 b + 1/16 b) Fb 1/EJ = -7/48 Fb^2/EJ$$

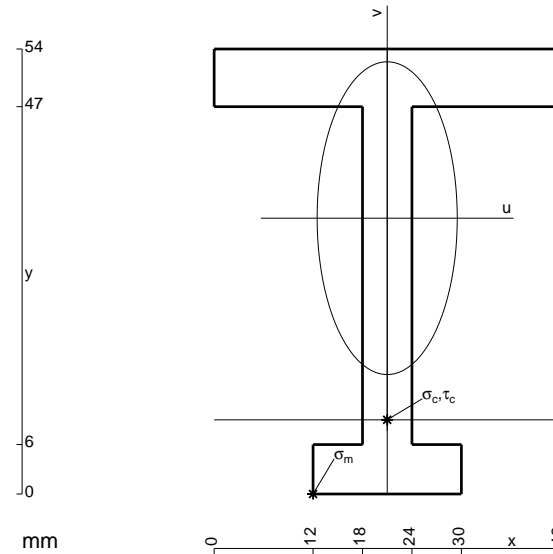

- A = 648. mm²
- J_u = 233472. mm⁴
- J_v = 46872. mm⁴
- y_g = 33.47 mm
- T_y = -1740. N
- M_x = -1670400. Nmm
- x_m = 12. mm
- u_m = -9. mm
- v_m = -33.47 mm
- σ_m = -Mv/J_u = -239.5 N/mm²
- x_c = 21. mm
- y_c = 9. mm
- v_c = -24.47 mm
- σ_c = -Mv/J_u = -175.1 N/mm²
- τ_c = 4.669 N/mm²
- σ_q = √σ²+3τ² = 175.3 N/mm²
- S = 3759. mm³

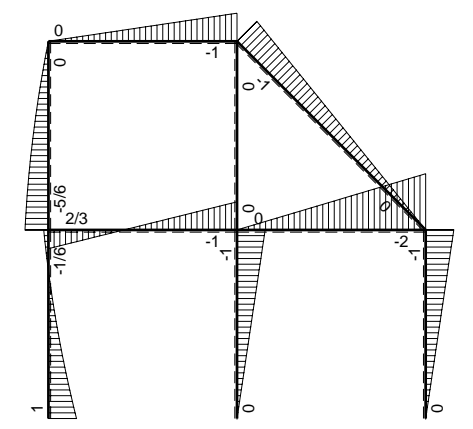
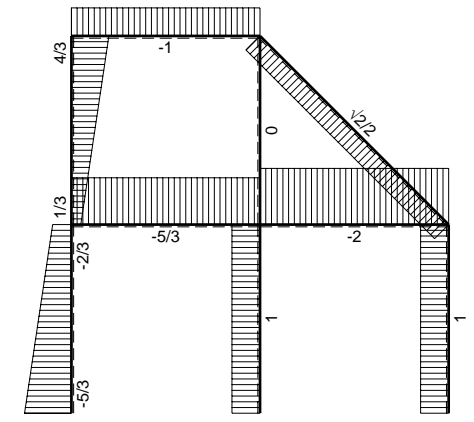
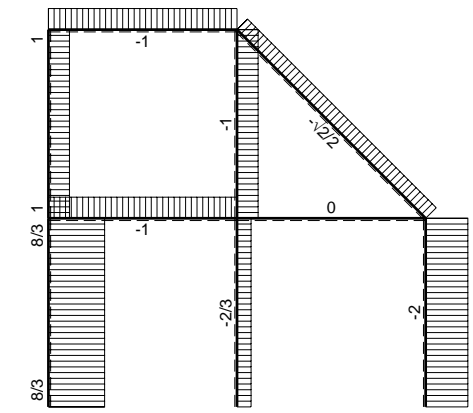
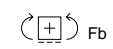
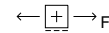
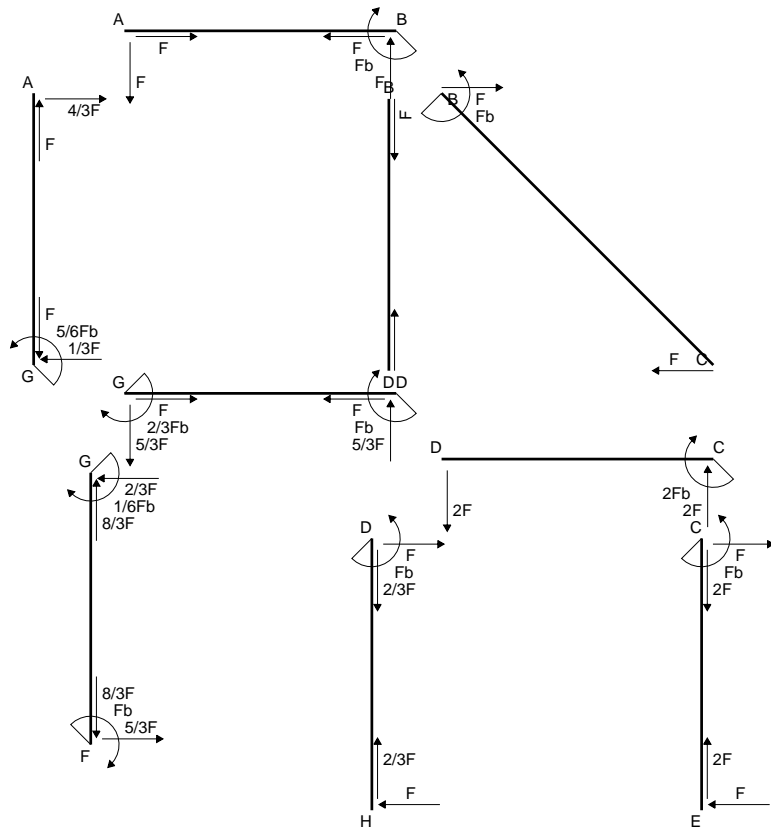

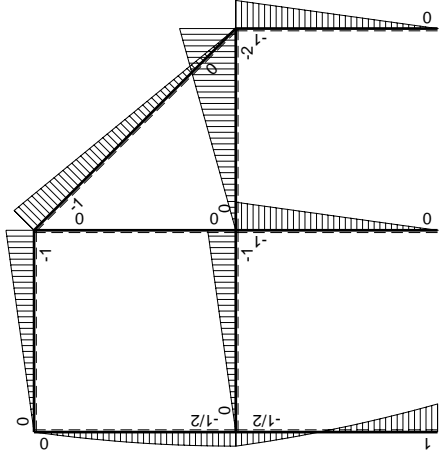
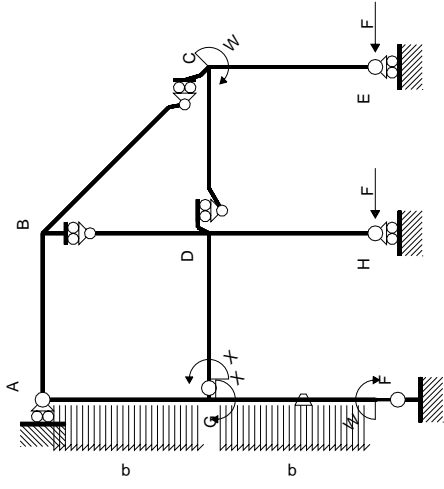

Schema di calcolo iperstatico

M_0 flessione da carichi assegnati

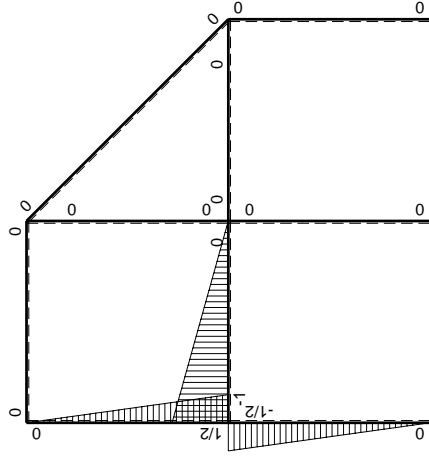

M_1 flessione da iperstatica $X=1$

Quadro contributi PLV per iperstatica $X=W_{GD}$

→	$M_x(x)$	$M_o(x)$	θ	$M_x M_o$	$M_x \theta$	$M_x M_x$	$\int M_x(M_o/EJ+\theta)dx$	$\int X M_x M_x/EJdx$	
AB b	0	-Fx	0	0	0	0	0+0	0	
BA b	0	Fb-Fx	0	0	0	0			
BC $\sqrt{2}b$	0	-Fb+ $\sqrt{2}/2Fx$	0	0	0	0	0	0	
BD b	0	0	0	0	0	0	0+0	0	
DB b	0	0	0	0	0	0			
DC b	0	-2Fx	0	0	0	0	0+0	0	
CD b	0	2Fb-2Fx	0	0	0	0			
CE b	0	-Fb+Fx	0	0	0	0	0+0	0	
EC b	0	Fx	0	0	0	0			
FG b	-1/2x/b	Fb-2Fx+1/2qx ²	-Fb/EJ	-1/2Fx+Fx ² /b-1/4qx ³ /b	1/2Fx/EJ	1/4x ² /b ²	(1/48+1/4)Fb ² /EJ	1/12Xb/EJ	
GF b	1/2-1/2x/b	1/2Fb-Fx-1/2qx ²	Fb/EJ	1/4Fb-3/4Fx+1/4Fx ² /b+1/4qx ³ /b	1/2Fb/EJ-1/2Fx/EJ	1/4-1/2x/b+1/4x ² /b ²			
GD b	-1+x/b	-Fx	0	Fx-Fx ² /b	0	1-2x/b+x ² /b ²	(1/6+0)Fb ² /EJ	1/3Xb/EJ	
DG b	x/b	Fb-Fx	0	Fx-Fx ² /b	0	x ² /b ²			
DH b	0	-Fb+Fx	0	0	0	0	0+0	0	
HD b	0	Fx	0	0	0	0			
GA b	1/2-1/2x/b	-1/2Fb+1/2qx ²	0	-1/4Fb+1/4Fx+1/4Fx ² /b-1/4qx ³ /b	0	1/4-1/2x/b+1/4x ² /b ²	(-5/48+0)Fb ² /EJ	1/12Xb/EJ	
AG b	-1/2x/b	Fx-1/2qx ²	0	-1/2Fx ² /b+1/4qx ³ /b	0	1/4x ² /b ²			
	totali							1/3Fb ² /EJ	1/2Xb/EJ
	iperstatica $X=W_{GD}$							-2/3Fb	

Sviluppi di calcolo iperstatica

$$L_{FG}^{xx} = \int_0^b (1/4 x^2/b^2) 1/EJ dx = [1/12 x^3/b^2]_0^b 1/EJ$$

$$= (1/12 b) 1/EJ = 1/12 b/EJ$$

$$L_{GF}^{xx} = \int_0^b (1/4 - 1/2 x/b + 1/4 x^2/b^2) 1/EJ dx = [1/4 x - 1/4 x^2/b + 1/12 x^3/b^2]_0^b 1/EJ$$

$$= (1/4 b - 1/4 b + 1/12 b) 1/EJ = 1/12 b/EJ$$

$$L_{GD}^{xx} = \int_0^b (1 - 2 x/b + x^2/b^2) 1/EJ dx = [x - x^2/b + 1/3 x^3/b^2]_0^b 1/EJ$$

$$= (b - b + 1/3 b) 1/EJ = 1/3 b/EJ$$

$$L_{DG}^{xx} = \int_0^b (x^2/b^2) 1/EJ dx = [1/3 x^3/b^2]_0^b 1/EJ$$

$$= (1/3 b) 1/EJ = 1/3 b/EJ$$

$$L_{GA}^{xx} = \int_0^b (1/4 - 1/2 x/b + 1/4 x^2/b^2) 1/EJ dx = [1/4 x - 1/4 x^2/b + 1/12 x^3/b^2]_0^b 1/EJ$$

$$= (1/4 b - 1/4 b + 1/12 b) 1/EJ = 1/12 b/EJ$$

$$L_{AG}^{xx} = \int_0^b (1/4 x^2/b^2) 1/EJ dx = [1/12 x^3/b^2]_0^b 1/EJ$$

$$= (1/12 b) 1/EJ = 1/12 b/EJ$$

$$L_{FG}^{xo} = \int_0^b (-1/2 x/b + x^2/b^2 - 1/4 x^3/b^3) Fb 1/EJ dx + \int_0^b (1/2 x/b) \theta dx$$

$$= [-1/4 x^2/b + 1/3 x^3/b^2 - 1/16 x^4/b^3]_0^b Fb 1/EJ + [1/4 x^2/b]_0^b \theta$$

$$= (-1/4 b + 1/3 b - 1/16 b) Fb 1/EJ + (1/4 b) \theta = 13/48 Fb^2/EJ$$

$$L_{GF}^{xo} = \int_0^b (1/4 - 3/4 x/b + 1/4 x^2/b^2 + 1/4 x^3/b^3) Fb 1/EJ dx + \int_0^b (-1/2 + 1/2 x/b) \theta dx$$

$$= [1/4 x - 3/8 x^2/b + 1/12 x^3/b^2 + 1/16 x^4/b^3]_0^b Fb 1/EJ + [-1/2 x + 1/4 x^2/b]_0^b \theta$$

$$= (1/4 b - 3/8 b + 1/12 b + 1/16 b) Fb 1/EJ + (-1/2 b + 1/4 b) \theta = 13/48 Fb^2/EJ$$

$$L_{GD}^{xo} = \int_0^b (x/b - x^2/b^2) Fb 1/EJ dx = [1/2 x^2/b - 1/3 x^3/b^2]_0^b Fb 1/EJ$$

$$= (1/2 b - 1/3 b) Fb 1/EJ = 1/6 Fb^2/EJ$$

$$L_{DG}^{xo} = \int_0^b (x/b - x^2/b^2) Fb 1/EJ dx = [1/2 x^2/b - 1/3 x^3/b^2]_0^b Fb 1/EJ$$

$$= (1/2 b - 1/3 b) Fb 1/EJ = 1/6 Fb^2/EJ$$

$$L_{GA}^{xo} = \int_0^b (-1/4 + 1/4 x/b + 1/4 x^2/b^2 - 1/4 x^3/b^3) Fb 1/EJ dx$$

$$= [-1/4 x + 1/8 x^2/b + 1/12 x^3/b^2 - 1/16 x^4/b^3]_0^b Fb 1/EJ$$

$$= (-1/4 b + 1/8 b + 1/12 b - 1/16 b) Fb 1/EJ = -5/48 Fb^2/EJ$$

$$L_{AG}^{xo} = \int_0^b (-1/2 x^2/b^2 + 1/4 x^3/b^3) Fb 1/EJ dx = [-1/6 x^3/b^2 + 1/16 x^4/b^3]_0^b Fb 1/EJ$$

$$= (-1/6 b + 1/16 b) Fb 1/EJ = -5/48 Fb^2/EJ$$

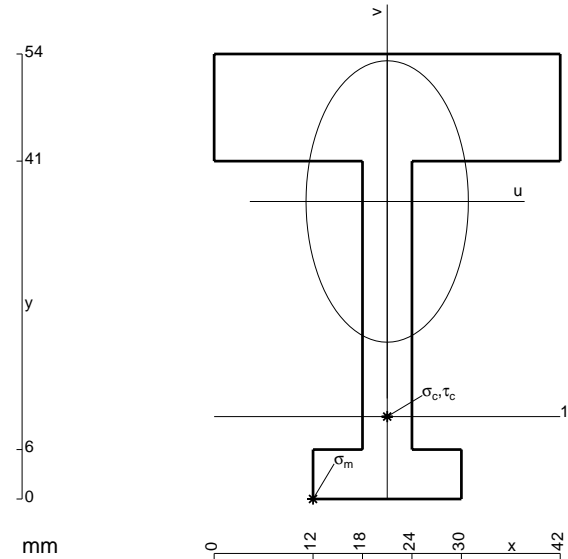

$$A = 864. \text{ mm}^2$$

$$J_u = 252075. \text{ mm}^4$$

$$J_v = 83808. \text{ mm}^4$$

$$y_g = 36.1 \text{ mm}$$

$$T_y = -2720. \text{ N}$$

$$M_x = -1387200. \text{ Nmm}$$

$$x_m = 12. \text{ mm}$$

$$u_m = -9. \text{ mm}$$

$$v_m = -36.1 \text{ mm}$$

$$\sigma_m = -Mv/J_u = -198.7 \text{ N/mm}^2$$

$$x_c = 21. \text{ mm}$$

$$y_c = 10. \text{ mm}$$

$$v_c = -26.1 \text{ mm}$$

$$\sigma_c = -Mv/J_u = -143.7 \text{ N/mm}^2$$

$$\tau_c = 7.643 \text{ N/mm}^2$$

$$\sigma_q = \sqrt{\sigma^2 + 3\tau^2} = 144.3 \text{ N/mm}^2$$

$$S = 4250. \text{ mm}^3$$

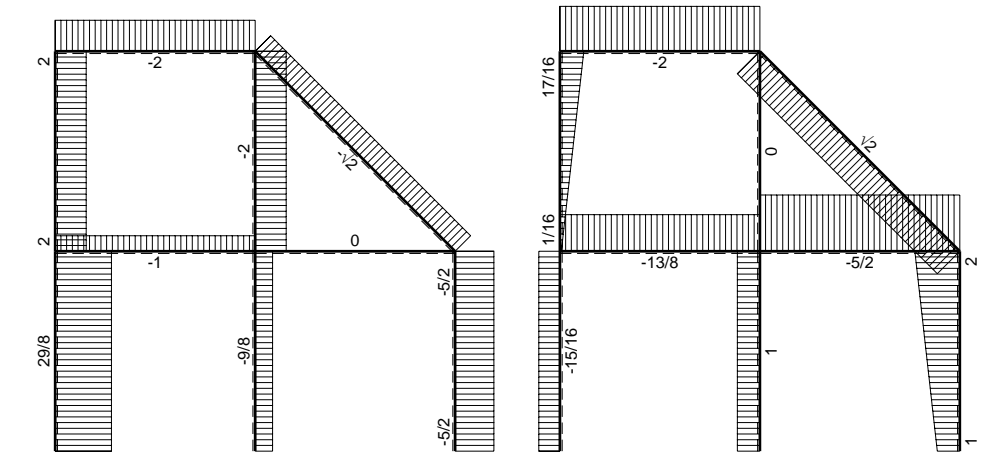
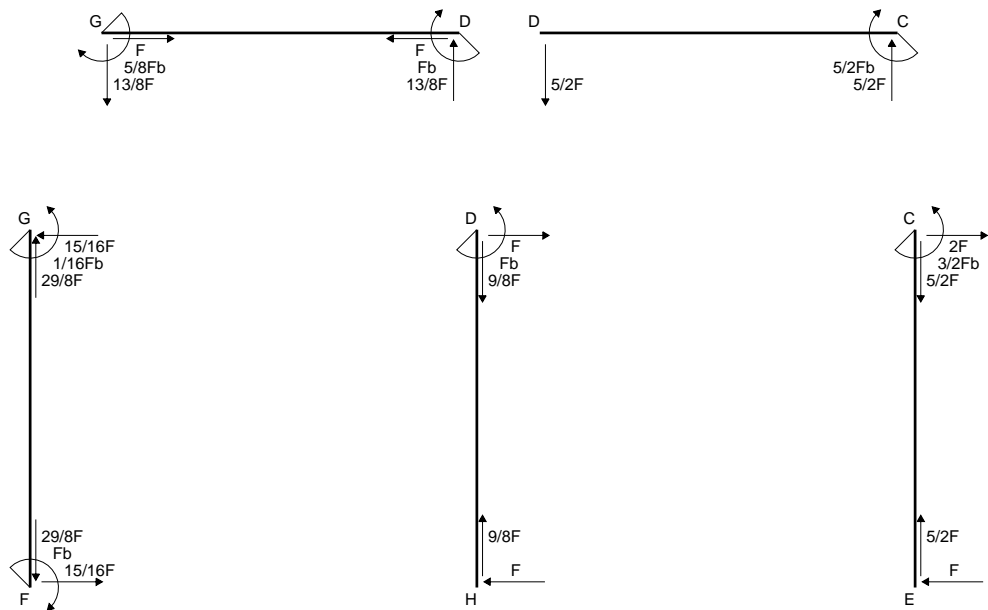
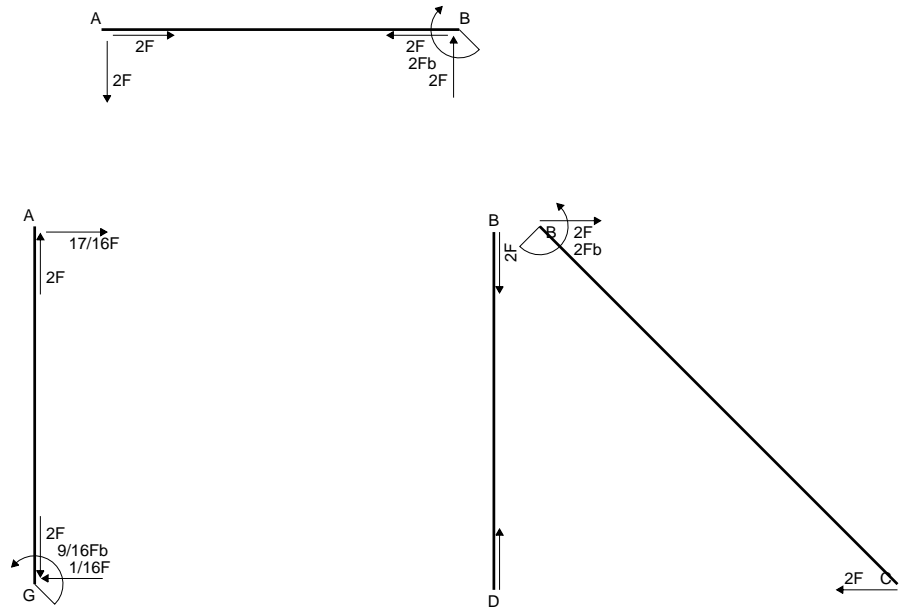

← ⊕ → F

↑ ⊕ ↓ Fb

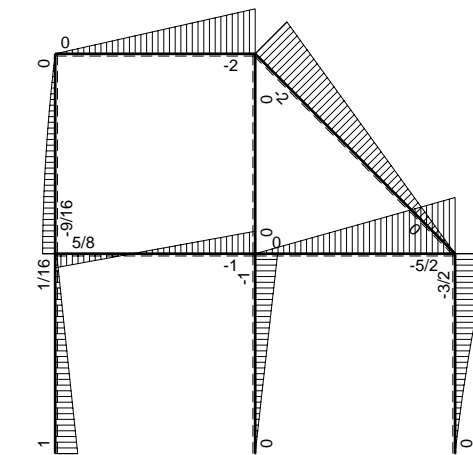

⊕ ⊖ Fb

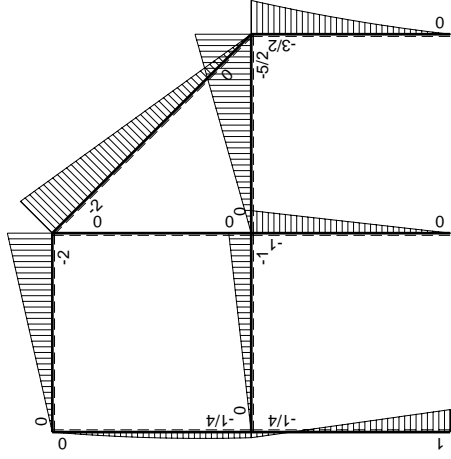
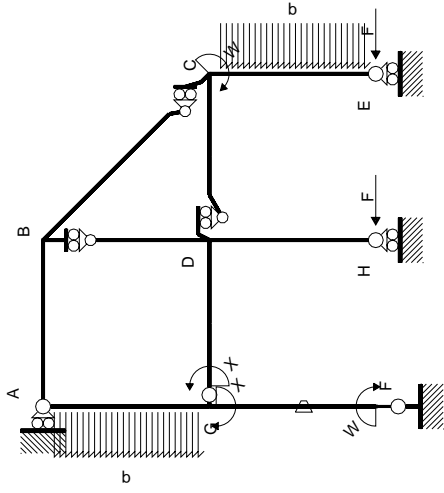

Schema di calcolo iperstatico

M_0 flessione da carichi assegnati

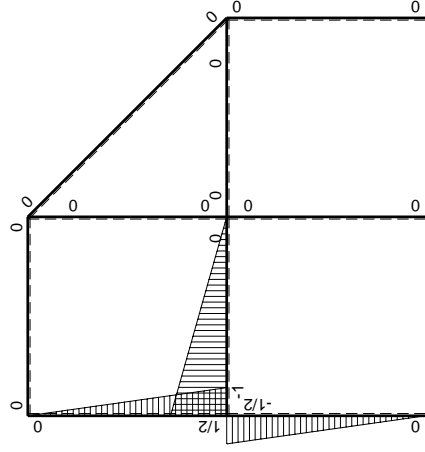

M_x flessione da iperstatica $X=1$

Quadro contributi PLV per iperstatica $X=W_{GD}$

→	$M_x(x)$	$M_o(x)$	θ	$M_x M_o$	$M_x \theta$	$M_x M_x$	$\int M_x(M_o/EJ+\theta)dx$	$\int X M_x M_x/EJ dx$	
AB b	0	-2Fx	0	0	0	0	0+0	0	
BA b	0	2Fb-2Fx	0	0	0	0	0	0	
BC $\sqrt{2}b$	0	-2Fb+ $\sqrt{2}Fx$	0	0	0	0	0	0	
BD b	0	0	0	0	0	0	0+0	0	
DB b	0	0	0	0	0	0	0	0	
DC b	0	-5/2Fx	0	0	0	0	0+0	0	
CD b	0	5/2Fb-5/2Fx	0	0	0	0	0	0	
CE b	0	-3/2Fb+2Fx-1/2qx ²	0	0	0	0	0+0	0	
EC b	0	Fx+1/2qx ²	0	0	0	0	0	0	
FG b	-1/2x/b	Fb-5/4Fx	-Fb/EJ	-1/2Fx+5/8Fx ² /b	1/2Fx/EJ	1/4x ² /b ²	(-1/24+1/4)Fb ² /EJ	1/12Xb/EJ	
GF b	1/2-1/2x/b	1/4Fb-5/4Fx	Fb/EJ	1/8Fb-3/4Fx+5/8Fx ² /b	1/2Fb/EJ-1/2Fx/EJ	1/4-1/2x/b+1/4x ² /b ²			
GD b	-1+x/b	-Fx	0	Fx-Fx ² /b	0	1-2x/b+x ² /b ²	(1/6+0)Fb ² /EJ	1/3Xb/EJ	
DG b	x/b	Fb-Fx	0	Fx-Fx ² /b	0	x ² /b ²			
DH b	0	-Fb+Fx	0	0	0	0	0+0	0	
HD b	0	Fx	0	0	0	0	0	0	
GA b	1/2-1/2x/b	-1/4Fb-1/4Fx+1/2qx ²	0	-1/8Fb+3/8Fx ² /b-1/4qx ³ /b	0	1/4-1/2x/b+1/4x ² /b ²	(-1/16+0)Fb ² /EJ	1/12Xb/EJ	
AG b	-1/2x/b	3/4Fx-1/2qx ²	0	-3/8Fx ² /b+1/4qx ³ /b	0	1/4x ² /b ²			
	totali							5/16Fb ² /EJ	1/2Xb/EJ
	iperstatica $X=W_{GD}$							-5/8Fb	

Sviluppi di calcolo iperstatica

$$L_{FG}^{xx} = \int_0^b (1/4 x^2/b^2) 1/EJ dx = [1/12 x^3/b^2]_0^b 1/EJ$$

$$= (1/12 b) 1/EJ = 1/12 b/EJ$$

$$L_{GF}^{xx} = \int_0^b (1/4 - 1/2 x/b + 1/4 x^2/b^2) 1/EJ dx = [1/4 x - 1/4 x^2/b + 1/12 x^3/b^2]_0^b 1/EJ$$

$$= (1/4 b - 1/4 b + 1/12 b) 1/EJ = 1/12 b/EJ$$

$$L_{GD}^{xx} = \int_0^b (1 - 2 x/b + x^2/b^2) 1/EJ dx = [x - x^2/b + 1/3 x^3/b^2]_0^b 1/EJ$$

$$= (b - b + 1/3 b) 1/EJ = 1/3 b/EJ$$

$$L_{DG}^{xx} = \int_0^b (x^2/b^2) 1/EJ dx = [1/3 x^3/b^2]_0^b 1/EJ$$

$$= (1/3 b) 1/EJ = 1/3 b/EJ$$

$$L_{GA}^{xx} = \int_0^b (1/4 - 1/2 x/b + 1/4 x^2/b^2) 1/EJ dx = [1/4 x - 1/4 x^2/b + 1/12 x^3/b^2]_0^b 1/EJ$$

$$= (1/4 b - 1/4 b + 1/12 b) 1/EJ = 1/12 b/EJ$$

$$L_{AG}^{xx} = \int_0^b (1/4 x^2/b^2) 1/EJ dx = [1/12 x^3/b^2]_0^b 1/EJ$$

$$= (1/12 b) 1/EJ = 1/12 b/EJ$$

$$L_{FG}^{xo} = \int_0^b (-1/2 x/b + 5/8 x^2/b^2) Fb 1/EJ dx + \int_0^b (1/2 x/b) \theta dx$$

$$= [-1/4 x^2/b + 5/24 x^3/b^2]_0^b Fb 1/EJ + [1/4 x^2/b]_0^b \theta$$

$$= (-1/4 b + 5/24 b) Fb 1/EJ + (1/4 b) \theta = 5/24 Fb^2/EJ$$

$$L_{GF}^{xo} = \int_0^b (1/8 - 3/4 x/b + 5/8 x^2/b^2) Fb 1/EJ dx + \int_0^b (-1/2 + 1/2 x/b) \theta dx$$

$$= [1/8 x - 3/8 x^2/b + 5/24 x^3/b^2]_0^b Fb 1/EJ + [-1/2 x + 1/4 x^2/b]_0^b \theta$$

$$= (1/8 b - 3/8 b + 5/24 b) Fb 1/EJ + (-1/2 b + 1/4 b) \theta = 5/24 Fb^2/EJ$$

$$L_{GD}^{xo} = \int_0^b (x/b - x^2/b^2) Fb 1/EJ dx = [1/2 x^2/b - 1/3 x^3/b^2]_0^b Fb 1/EJ$$

$$= (1/2 b - 1/3 b) Fb 1/EJ = 1/6 Fb^2/EJ$$

$$L_{DG}^{xo} = \int_0^b (x/b - x^2/b^2) Fb 1/EJ dx = [1/2 x^2/b - 1/3 x^3/b^2]_0^b Fb 1/EJ$$

$$= (1/2 b - 1/3 b) Fb 1/EJ = 1/6 Fb^2/EJ$$

$$L_{GA}^{xo} = \int_0^b (-1/8 + 3/8 x^2/b^2 - 1/4 x^3/b^3) Fb 1/EJ dx = [-1/8 x + 1/8 x^3/b^2 - 1/16 x^4/b^3]_0^b Fb 1/EJ$$

$$= (-1/8 b + 1/8 b - 1/16 b) Fb 1/EJ = -1/16 Fb^2/EJ$$

$$L_{AG}^{xo} = \int_0^b (-3/8 x^2/b^2 + 1/4 x^3/b^3) Fb 1/EJ dx = [-1/8 x^3/b^2 + 1/16 x^4/b^3]_0^b Fb 1/EJ$$

$$= (-1/8 b + 1/16 b) Fb 1/EJ = -1/16 Fb^2/EJ$$

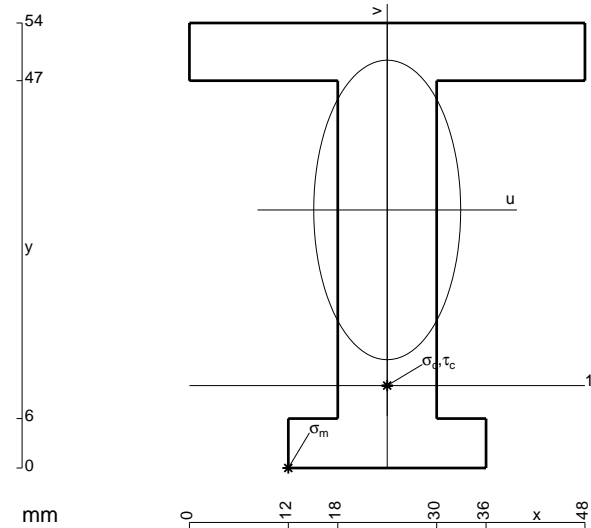

- A = 972. mm²
- J_u = 321252. mm⁴
- J_v = 77328. mm⁴
- y_g = 31.31 mm
- T_y = -3825. N
- M_x = -2142000. Nmm
- x_m = 12. mm
- u_m = -12. mm
- v_m = -31.31 mm
- σ_m = -Mv/J_u = -208.8 N/mm²
- x_c = 24. mm
- y_c = 10. mm
- v_c = -21.31 mm
- σ_c = -Mv/J_u = -142.1 N/mm²
- τ_c = 5.156 N/mm²
- σ_q = √σ²+3τ² = 142.4 N/mm²
- S = 5196. mm³

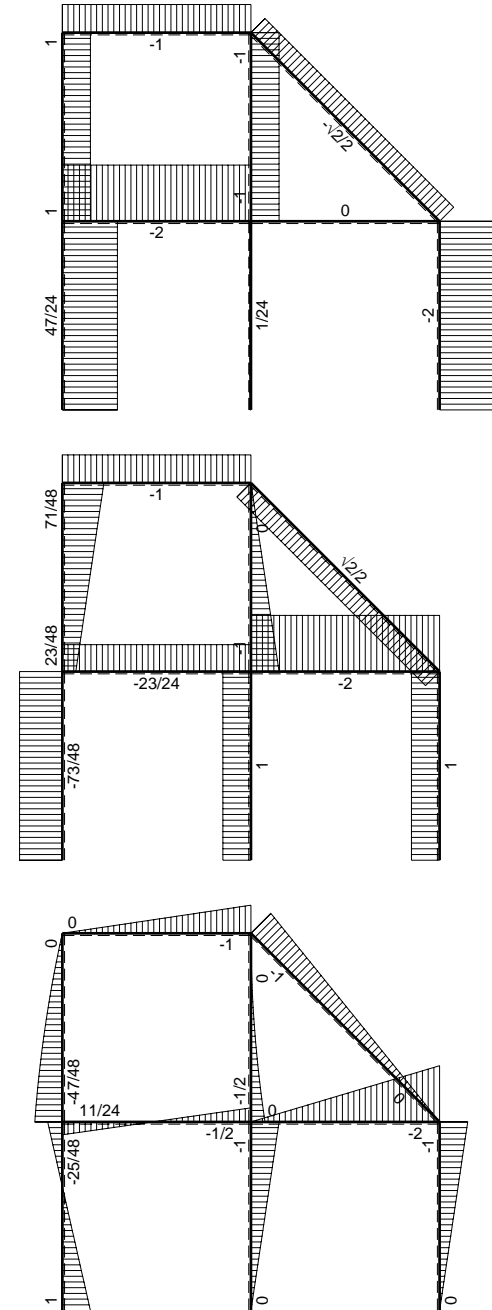
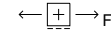
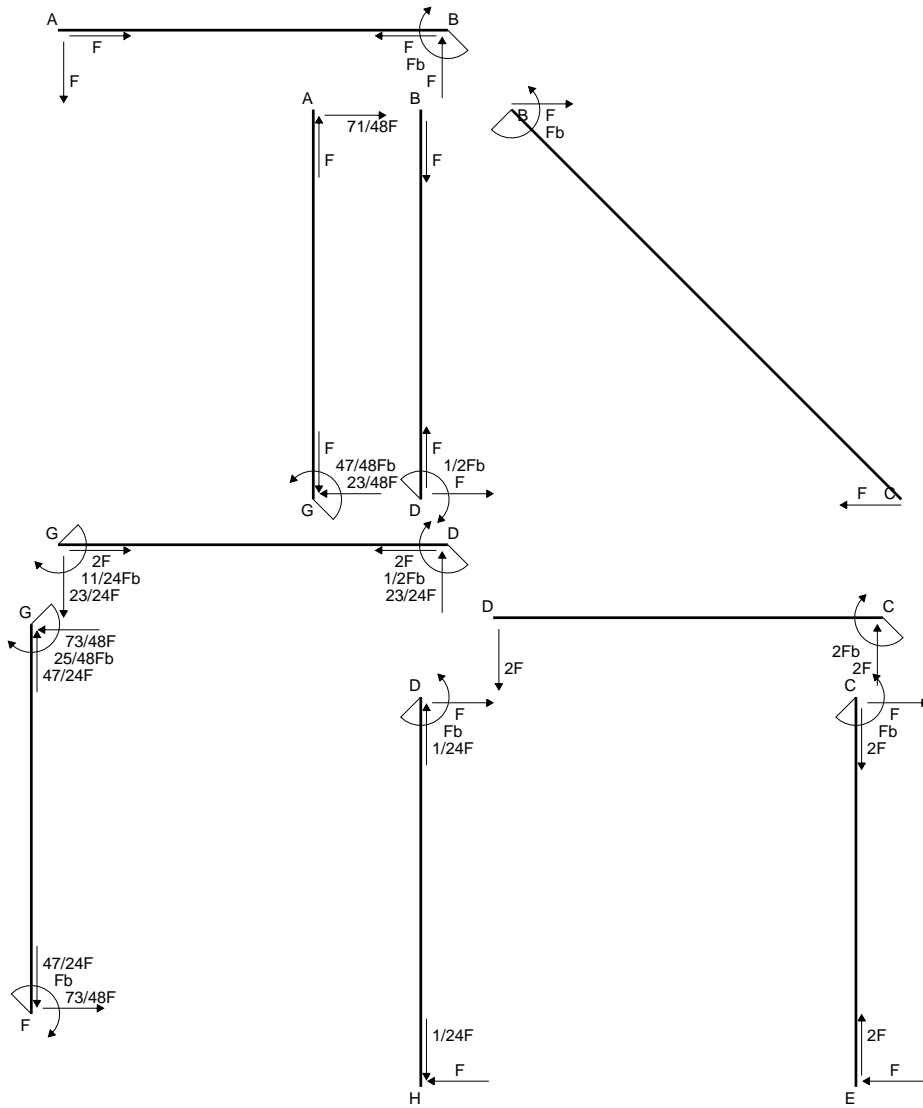

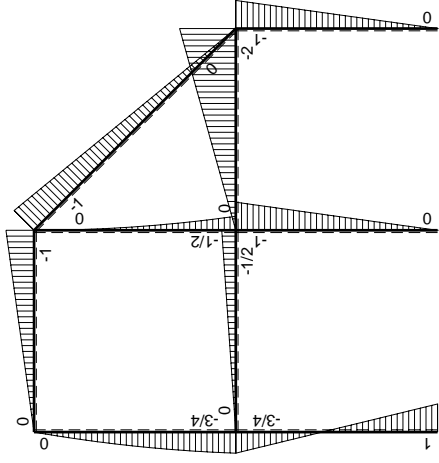
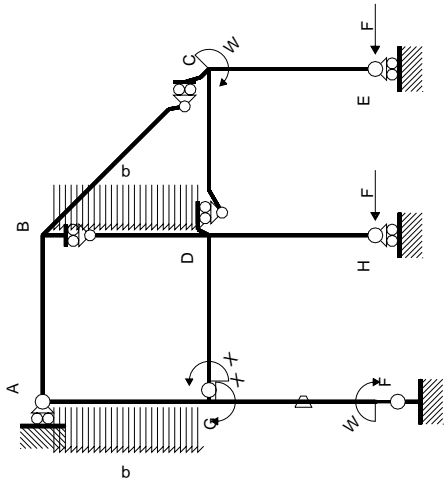

Schema di calcolo iperstatico

M_0 flessione da carichi assegnati



M_x flessione da iperstatica $X=1$

Quadro contributi PLV per iperstatica $X=W_{GD}$

→	$M_x(x)$	$M_o(x)$	θ	$M_x M_o$	$M_x \theta$	$M_x M_x$	$\int M_x(M_o/EJ+\theta)dx$	$\int X M_x M_x/EJ dx$
AB b	0	-Fx	0	0	0	0	0+0	0
BA b	0	Fb-Fx	0	0	0	0	0	0
BC $\sqrt{2}b$	0	-Fb+ $\sqrt{2}/2Fx$	0	0	0	0	0	0
BD b	0	-1/2qx ²	0	0	0	0	0+0	0
DB b	0	1/2Fb-Fx+1/2qx ²	0	0	0	0	0	0
DC b	0	-2Fx	0	0	0	0	0+0	0
CD b	0	2Fb-2Fx	0	0	0	0	0	0
CE b	0	-Fb+Fx	0	0	0	0	0+0	0
EC b	0	Fx	0	0	0	0	0	0
FG b	-1/2x/b	Fb-7/4Fx	-Fb/EJ	-1/2Fx+7/8Fx ² /b	1/2Fx/EJ	1/4x ² /b ²	(1/24+1/4)Fb ² /EJ	1/12Xb/EJ
GF b	1/2-1/2x/b	3/4Fb-7/4Fx	Fb/EJ	3/8Fb-5/4Fx+7/8Fx ² /b	1/2Fb/EJ-1/2Fx/EJ	1/4-1/2x/b+1/4x ² /b ²		
GD b	-1+x/b	-1/2Fx	0	1/2Fx-1/2Fx ² /b	0	1-2x/b+x ² /b ²	(1/12+0)Fb ² /EJ	1/3Xb/EJ
DG b	x/b	1/2Fb-1/2Fx	0	1/2Fx-1/2Fx ² /b	0	x ² /b ²		
DH b	0	-Fb+Fx	0	0	0	0	0+0	0
HD b	0	Fx	0	0	0	0	0	0
GA b	1/2-1/2x/b	-3/4Fb+1/4Fx+1/2qx ²	0	-3/8Fb+1/2Fx+1/8Fx ² /b-1/4qx ³ /b	0	1/4-1/2x/b+1/4x ² /b ²	(-7/48+0)Fb ² /EJ	1/12Xb/EJ
AG b	-1/2x/b	5/4Fx-1/2qx ²	0	-5/8Fx ² /b+1/4qx ³ /b	0	1/4x ² /b ²		
	totali						11/48Fb ² /EJ	1/2Xb/EJ
	iperstatica $X=W_{GD}$						-11/24Fb	

Sviluppi di calcolo iperstatica

$$L_{FG}^{xx} = \int_0^b (1/4 x^2/b^2) 1/EJ dx = [1/12 x^3/b^2]_0^b 1/EJ$$

$$= (1/12 b) 1/EJ = 1/12 b/EJ$$

$$L_{GF}^{xx} = \int_0^b (1/4 - 1/2 x/b + 1/4 x^2/b^2) 1/EJ dx = [1/4 x - 1/4 x^2/b + 1/12 x^3/b^2]_0^b 1/EJ$$

$$= (1/4 b - 1/4 b + 1/12 b) 1/EJ = 1/12 b/EJ$$

$$L_{GD}^{xx} = \int_0^b (1 - 2 x/b + x^2/b^2) 1/EJ dx = [x - x^2/b + 1/3 x^3/b^2]_0^b 1/EJ$$

$$= (b - b + 1/3 b) 1/EJ = 1/3 b/EJ$$

$$L_{DG}^{xx} = \int_0^b (x^2/b^2) 1/EJ dx = [1/3 x^3/b^2]_0^b 1/EJ$$

$$= (1/3 b) 1/EJ = 1/3 b/EJ$$

$$L_{GA}^{xx} = \int_0^b (1/4 - 1/2 x/b + 1/4 x^2/b^2) 1/EJ dx = [1/4 x - 1/4 x^2/b + 1/12 x^3/b^2]_0^b 1/EJ$$

$$= (1/4 b - 1/4 b + 1/12 b) 1/EJ = 1/12 b/EJ$$

$$L_{AG}^{xx} = \int_0^b (1/4 x^2/b^2) 1/EJ dx = [1/12 x^3/b^2]_0^b 1/EJ$$

$$= (1/12 b) 1/EJ = 1/12 b/EJ$$

$$L_{FG}^{xo} = \int_0^b (-1/2 x/b + 7/8 x^2/b^2) Fb 1/EJ dx + \int_0^b (1/2 x/b) \theta dx$$

$$= [-1/4 x^2/b + 7/24 x^3/b^2]_0^b Fb 1/EJ + [1/4 x^2/b]_0^b \theta$$

$$= (-1/4 b + 7/24 b) Fb 1/EJ + (1/4 b) \theta = 7/24 Fb^2/EJ$$

$$L_{GF}^{xo} = \int_0^b (3/8 - 5/4 x/b + 7/8 x^2/b^2) Fb 1/EJ dx + \int_0^b (-1/2 + 1/2 x/b) \theta dx$$

$$= [3/8 x - 5/8 x^2/b + 7/24 x^3/b^2]_0^b Fb 1/EJ + [-1/2 x + 1/4 x^2/b]_0^b \theta$$

$$= (3/8 b - 5/8 b + 7/24 b) Fb 1/EJ + (-1/2 b + 1/4 b) \theta = 7/24 Fb^2/EJ$$

$$L_{GD}^{xo} = \int_0^b (1/2 x/b - 1/2 x^2/b^2) Fb 1/EJ dx = [1/4 x^2/b - 1/6 x^3/b^2]_0^b Fb 1/EJ$$

$$= (1/4 b - 1/6 b) Fb 1/EJ = 1/12 Fb^2/EJ$$

$$L_{DG}^{xo} = \int_0^b (1/2 x/b - 1/2 x^2/b^2) Fb 1/EJ dx = [1/4 x^2/b - 1/6 x^3/b^2]_0^b Fb 1/EJ$$

$$= (1/4 b - 1/6 b) Fb 1/EJ = 1/12 Fb^2/EJ$$

$$L_{GA}^{xo} = \int_0^b (-3/8 + 1/2 x/b + 1/8 x^2/b^2 - 1/4 x^3/b^3) Fb 1/EJ dx$$

$$= [-3/8 x + 1/4 x^2/b + 1/24 x^3/b^2 - 1/16 x^4/b^3]_0^b Fb 1/EJ$$

$$= (-3/8 b + 1/4 b + 1/24 b - 1/16 b) Fb 1/EJ = -7/48 Fb^2/EJ$$

$$L_{AG}^{xo} = \int_0^b (-5/8 x^2/b^2 + 1/4 x^3/b^3) Fb 1/EJ dx = [-5/24 x^3/b^2 + 1/16 x^4/b^3]_0^b Fb 1/EJ$$

$$= (-5/24 b + 1/16 b) Fb 1/EJ = -7/48 Fb^2/EJ$$

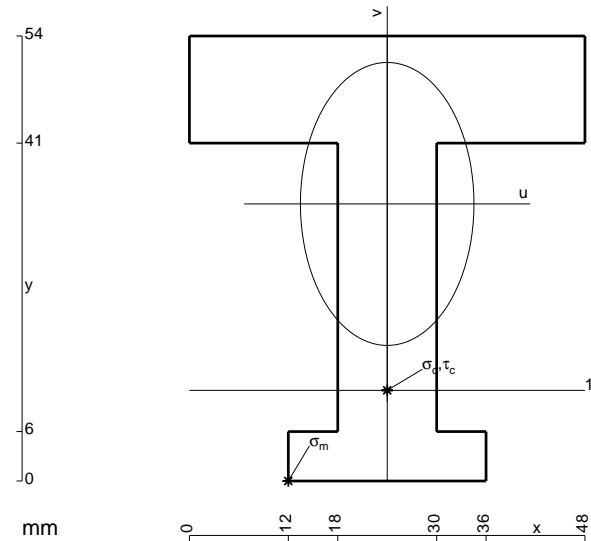

- A = 1188. mm²
- J_u = 350338. mm⁴
- J_v = 131760. mm⁴
- y_g = 33.62 mm
- T_y = -3740. N
- M_x = -2281400. Nmm
- x_m = 12. mm
- u_m = -12. mm
- v_m = -33.62 mm
- σ_m = -Mv/J_u = -218.9 N/mm²
- x_c = 24. mm
- y_c = 11. mm
- v_c = -22.62 mm
- σ_c = -Mv/J_u = -147.3 N/mm²
- τ_c = 5.264 N/mm²
- σ_q = √σ²+3τ² = 147.6 N/mm²
- S = 5917. mm³

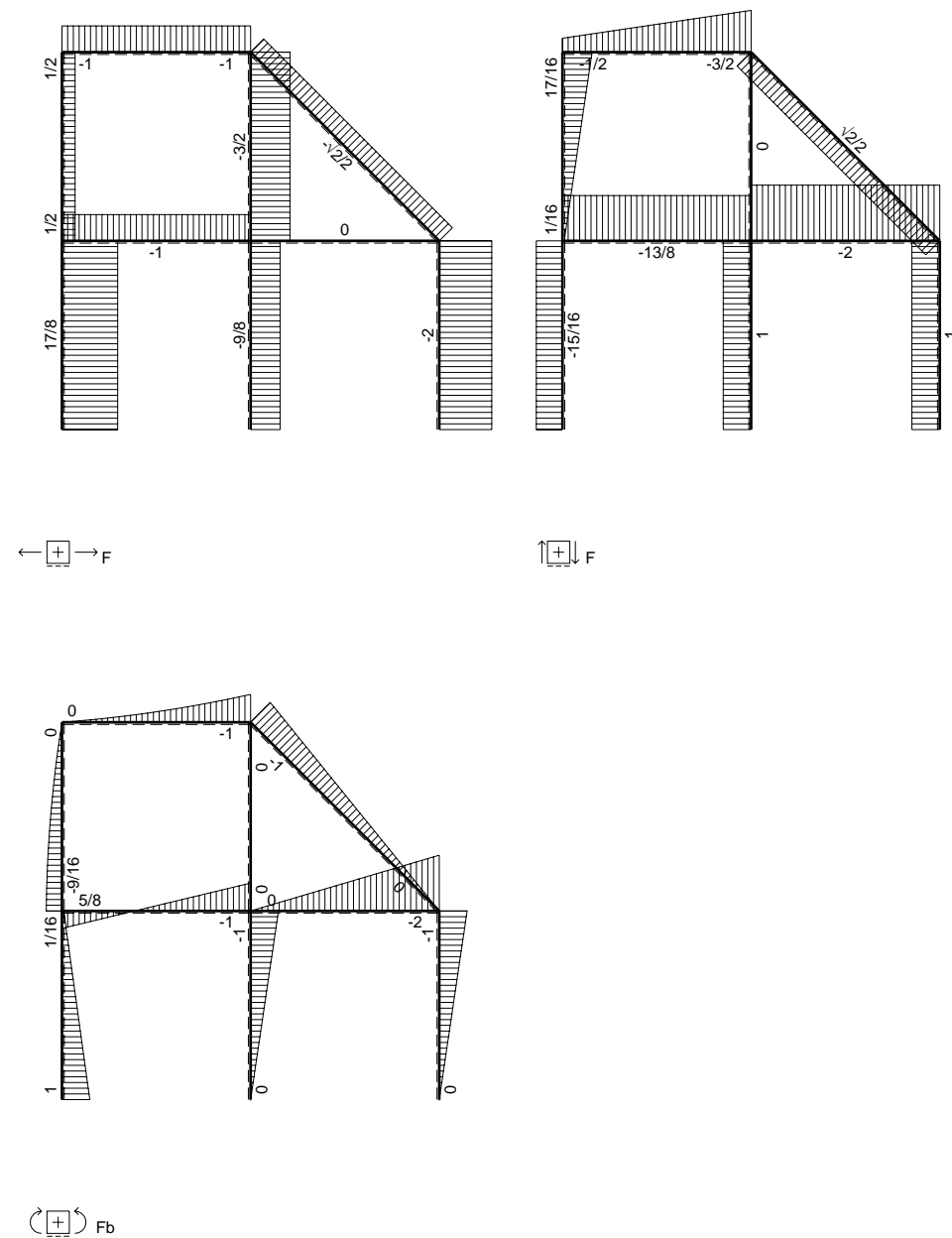
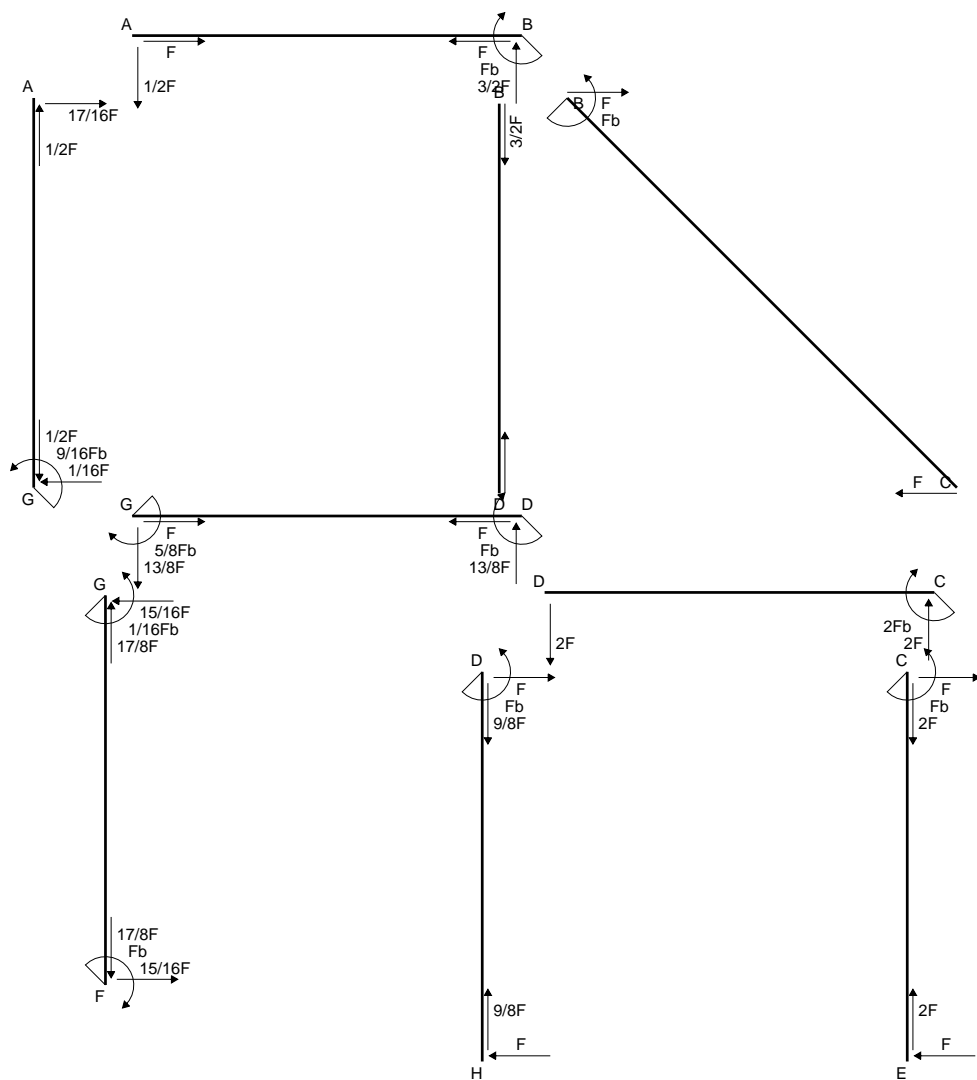

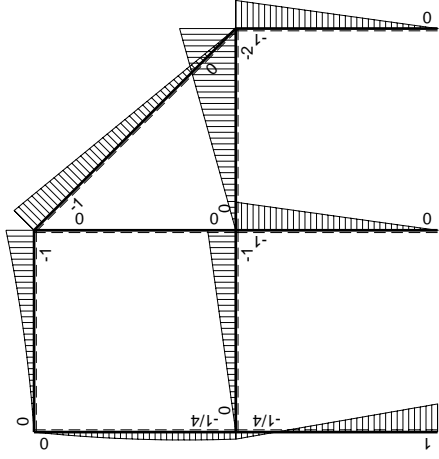
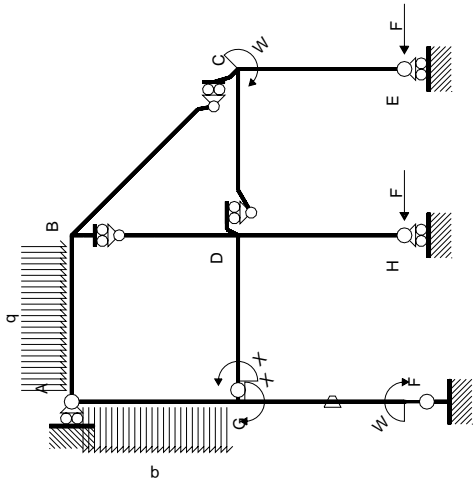

Schema di calcolo iperstatico

M_0 flessione da carichi assegnati



M_x flessione da iperstatica $X=1$

Quadro contributi PLV per iperstatica $X=W_{GD}$

→	$M_x(x)$	$M_o(x)$	θ	$M_x M_o$	$M_x \theta$	$M_x M_x$	$\int M_x(M_o/EJ+\theta)dx$	$\int X M_x M_x/EJ dx$	
AB b	0	$-1/2Fx-1/2qx^2$	0	0	0	0	0+0	0	
BA b	0	$Fb-3/2Fx+1/2qx^2$	0	0	0	0	0	0	
BC $\sqrt{2}b$	0	$-Fb+\sqrt{2}/2Fx$	0	0	0	0	0	0	
BD b	0	0	0	0	0	0	0+0	0	
DB b	0	0	0	0	0	0	0	0	
DC b	0	$-2Fx$	0	0	0	0	0+0	0	
CD b	0	$2Fb-2Fx$	0	0	0	0	0	0	
CE b	0	$-Fb+Fx$	0	0	0	0	0+0	0	
EC b	0	Fx	0	0	0	0	0	0	
FG b	$-1/2x/b$	$Fb-5/4Fx$	$-Fb/EJ$	$-1/2Fx+5/8Fx^2/b$	$1/2Fx/EJ$	$1/4x^2/b^2$	$(-1/24+1/4)Fb^2/EJ$	$1/12Xb/EJ$	
GF b	$1/2-1/2x/b$	$1/4Fb-5/4Fx$	Fb/EJ	$1/8Fb-3/4Fx+5/8Fx^2/b$	$1/2Fb/EJ-1/2Fx/EJ$	$1/4-1/2x/b+1/4x^2/b^2$			
GD b	$-1+x/b$	$-Fx$	0	$Fx-Fx^2/b$	0	$1-2x/b+x^2/b^2$	$(1/6+0)Fb^2/EJ$	$1/3Xb/EJ$	
DG b	x/b	$Fb-Fx$	0	$Fx-Fx^2/b$	0	x^2/b^2			
DH b	0	$-Fb+Fx$	0	0	0	0	0+0	0	
HD b	0	Fx	0	0	0	0	0	0	
GA b	$1/2-1/2x/b$	$-1/4Fb-1/4Fx+1/2qx^2$	0	$-1/8Fb+3/8Fx^2/b-1/4qx^3/b$	0	$1/4-1/2x/b+1/4x^2/b^2$	$(-1/16+0)Fb^2/EJ$	$1/12Xb/EJ$	
AG b	$-1/2x/b$	$3/4Fx-1/2qx^2$	0	$-3/8Fx^2/b+1/4qx^3/b$	0	$1/4x^2/b^2$			
	totali							$5/16Fb^2/EJ$	$1/2Xb/EJ$
	iperstatica $X=W_{GD}$							$-5/8Fb$	

Sviluppi di calcolo iperstatica

$$L_{FG}^{xx} = \int_0^b (1/4 x^2/b^2) 1/EJ dx = [1/12 x^3/b^2]_0^b 1/EJ$$

$$= (1/12 b) 1/EJ = 1/12 b/EJ$$

$$L_{GF}^{xx} = \int_0^b (1/4 - 1/2 x/b + 1/4 x^2/b^2) 1/EJ dx = [1/4 x - 1/4 x^2/b + 1/12 x^3/b^2]_0^b 1/EJ$$

$$= (1/4 b - 1/4 b + 1/12 b) 1/EJ = 1/12 b/EJ$$

$$L_{GD}^{xx} = \int_0^b (1 - 2 x/b + x^2/b^2) 1/EJ dx = [x - x^2/b + 1/3 x^3/b^2]_0^b 1/EJ$$

$$= (b - b + 1/3 b) 1/EJ = 1/3 b/EJ$$

$$L_{DG}^{xx} = \int_0^b (x^2/b^2) 1/EJ dx = [1/3 x^3/b^2]_0^b 1/EJ$$

$$= (1/3 b) 1/EJ = 1/3 b/EJ$$

$$L_{GA}^{xx} = \int_0^b (1/4 - 1/2 x/b + 1/4 x^2/b^2) 1/EJ dx = [1/4 x - 1/4 x^2/b + 1/12 x^3/b^2]_0^b 1/EJ$$

$$= (1/4 b - 1/4 b + 1/12 b) 1/EJ = 1/12 b/EJ$$

$$L_{AG}^{xx} = \int_0^b (1/4 x^2/b^2) 1/EJ dx = [1/12 x^3/b^2]_0^b 1/EJ$$

$$= (1/12 b) 1/EJ = 1/12 b/EJ$$

$$L_{FG}^{xo} = \int_0^b (-1/2 x/b + 5/8 x^2/b^2) Fb 1/EJ dx + \int_0^b (1/2 x/b) \theta dx$$

$$= [-1/4 x^2/b + 5/24 x^3/b^2]_0^b Fb 1/EJ + [1/4 x^2/b]_0^b \theta$$

$$= (-1/4 b + 5/24 b) Fb 1/EJ + (1/4 b) \theta = 5/24 Fb^2/EJ$$

$$L_{GF}^{xo} = \int_0^b (1/8 - 3/4 x/b + 5/8 x^2/b^2) Fb 1/EJ dx + \int_0^b (-1/2 + 1/2 x/b) \theta dx$$

$$= [1/8 x - 3/8 x^2/b + 5/24 x^3/b^2]_0^b Fb 1/EJ + [-1/2 x + 1/4 x^2/b]_0^b \theta$$

$$= (1/8 b - 3/8 b + 5/24 b) Fb 1/EJ + (-1/2 b + 1/4 b) \theta = 5/24 Fb^2/EJ$$

$$L_{GD}^{xo} = \int_0^b (x/b - x^2/b^2) Fb 1/EJ dx = [1/2 x^2/b - 1/3 x^3/b^2]_0^b Fb 1/EJ$$

$$= (1/2 b - 1/3 b) Fb 1/EJ = 1/6 Fb^2/EJ$$

$$L_{DG}^{xo} = \int_0^b (x/b - x^2/b^2) Fb 1/EJ dx = [1/2 x^2/b - 1/3 x^3/b^2]_0^b Fb 1/EJ$$

$$= (1/2 b - 1/3 b) Fb 1/EJ = 1/6 Fb^2/EJ$$

$$L_{GA}^{xo} = \int_0^b (-1/8 + 3/8 x^2/b^2 - 1/4 x^3/b^3) Fb 1/EJ dx = [-1/8 x + 1/8 x^3/b^2 - 1/16 x^4/b^3]_0^b Fb 1/EJ$$

$$= (-1/8 b + 1/8 b - 1/16 b) Fb 1/EJ = -1/16 Fb^2/EJ$$

$$L_{AG}^{xo} = \int_0^b (-3/8 x^2/b^2 + 1/4 x^3/b^3) Fb 1/EJ dx = [-1/8 x^3/b^2 + 1/16 x^4/b^3]_0^b Fb 1/EJ$$

$$= (-1/8 b + 1/16 b) Fb 1/EJ = -1/16 Fb^2/EJ$$

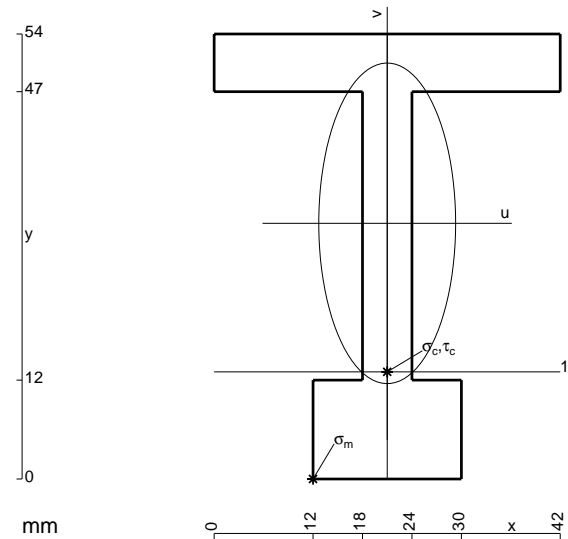

- A = 720. mm²
- J_u = 272496. mm⁴
- J_v = 49680. mm⁴
- y_g = 31.02 mm
- T_y = -3060. N
- M_x = -2019600. Nmm
- x_m = 12. mm
- u_m = -9. mm
- v_m = -31.02 mm
- σ_m = -Mv/J_u = -229.9 N/mm²
- x_c = 21. mm
- y_c = 13. mm
- v_c = -18.02 mm
- σ_c = -Mv/J_u = -133.6 N/mm²
- τ_c = 10.32 N/mm²
- σ_q = √σ²+3τ² = 134.8 N/mm²
- S = 5517. mm³

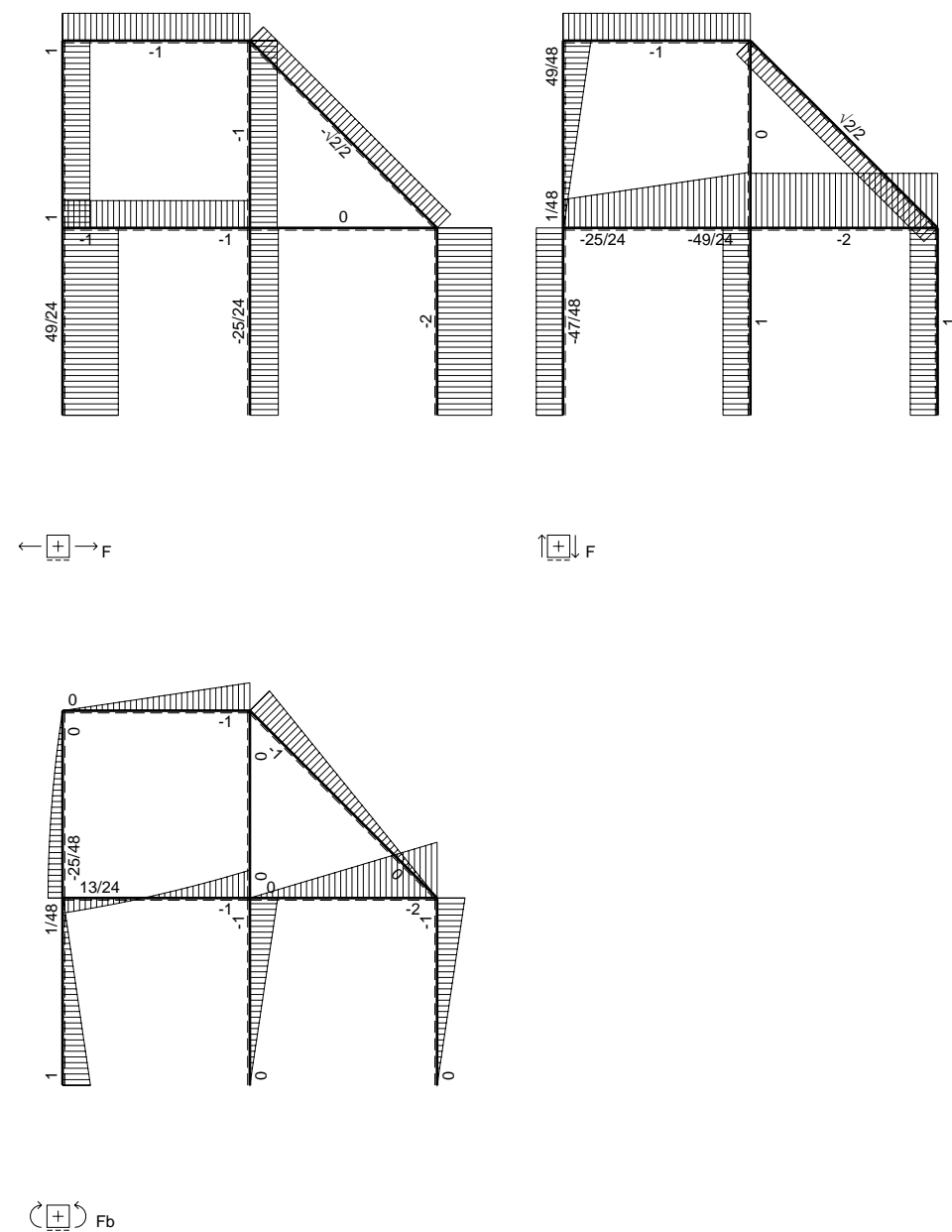
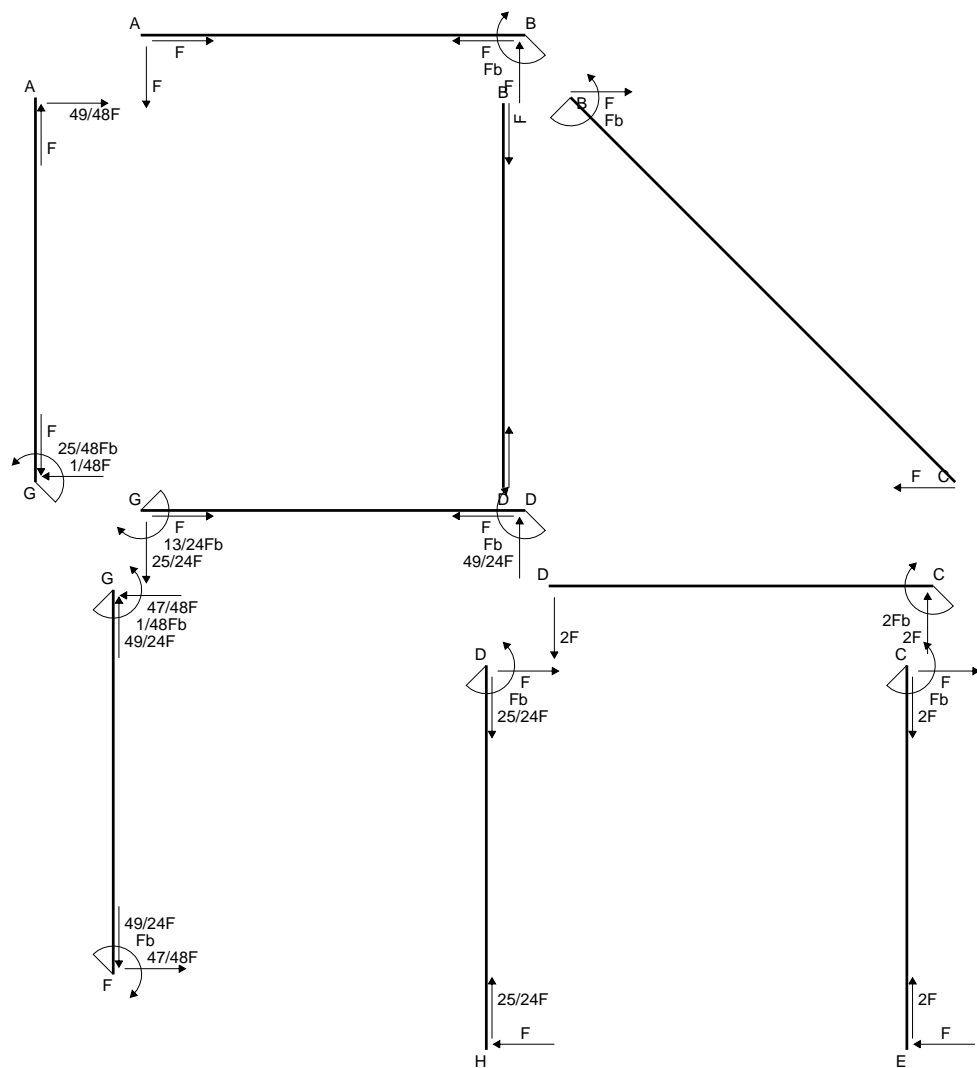

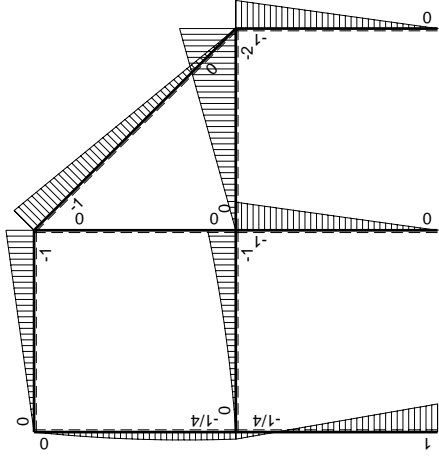
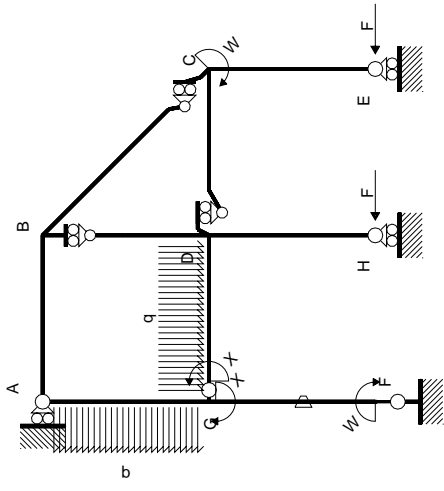

Schema di calcolo iperstatico

M_0 flessione da carichi assegnati



M_x flessione da iperstatica $X=1$

Quadro contributi PLV per iperstatica $X=W_{GD}$

→	$M_x(x)$	$M_o(x)$	θ	$M_x M_o$	$M_x \theta$	$M_x M_x$	$\int M_x(M_o/EJ+\theta)dx$	$\int X M_x M_x/EJ dx$	
AB b	0	-Fx	0	0	0	0	0+0	0	
BA b	0	Fb-Fx	0	0	0	0	0	0	
BC $\sqrt{2}b$	0	-Fb+ $\sqrt{2}/2Fx$	0	0	0	0	0	0	
BD b	0	0	0	0	0	0	0+0	0	
DB b	0	0	0	0	0	0	0	0	
DC b	0	-2Fx	0	0	0	0	0+0	0	
CD b	0	2Fb-2Fx	0	0	0	0	0	0	
CE b	0	-Fb+Fx	0	0	0	0	0+0	0	
EC b	0	Fx	0	0	0	0	0	0	
FG b	-1/2x/b	Fb-5/4Fx	-Fb/EJ	-1/2Fx+5/8Fx ² /b	1/2Fx/EJ	1/4x ² /b ²	(-1/24+1/4)Fb ² /EJ	1/12Xb/EJ	
GF b	1/2-1/2x/b	1/4Fb-5/4Fx	Fb/EJ	1/8Fb-3/4Fx+5/8Fx ² /b	1/2Fb/EJ-1/2Fx/EJ	1/4-1/2x/b+1/4x ² /b ²			
GD b	-1+x/b	-1/2Fx-1/2qx ²	0	1/2Fx-1/2qx ³ /b	0	1-2x/b+x ² /b ²	(1/8+0)Fb ² /EJ	1/3Xb/EJ	
DG b	x/b	Fb-3/2Fx+1/2qx ²	0	Fx-3/2Fx ² /b+1/2qx ³ /b	0	x ² /b ²			
DH b	0	-Fb+Fx	0	0	0	0	0+0	0	
HD b	0	Fx	0	0	0	0	0	0	
GA b	1/2-1/2x/b	-1/4Fb-1/4Fx+1/2qx ²	0	-1/8Fb+3/8Fx ² /b-1/4qx ³ /b	0	1/4-1/2x/b+1/4x ² /b ²	(-1/16+0)Fb ² /EJ	1/12Xb/EJ	
AG b	-1/2x/b	3/4Fx-1/2qx ²	0	-3/8Fx ² /b+1/4qx ³ /b	0	1/4x ² /b ²			
	totali							13/48Fb ² /EJ	1/2Xb/EJ
	iperstatica $X=W_{GD}$							-13/24Fb	

Sviluppi di calcolo iperstatica

$$L_{FG}^{xx} = \int_0^b (1/4 x^2/b^2) 1/EJ dx = [1/12 x^3/b^2]_0^b 1/EJ$$

$$= (1/12 b) 1/EJ = 1/12 b/EJ$$

$$L_{GF}^{xx} = \int_0^b (1/4 - 1/2 x/b + 1/4 x^2/b^2) 1/EJ dx = [1/4 x - 1/4 x^2/b + 1/12 x^3/b^2]_0^b 1/EJ$$

$$= (1/4 b - 1/4 b + 1/12 b) 1/EJ = 1/12 b/EJ$$

$$L_{GD}^{xx} = \int_0^b (1 - 2 x/b + x^2/b^2) 1/EJ dx = [x - x^2/b + 1/3 x^3/b^2]_0^b 1/EJ$$

$$= (b - b + 1/3 b) 1/EJ = 1/3 b/EJ$$

$$L_{DG}^{xx} = \int_0^b (x^2/b^2) 1/EJ dx = [1/3 x^3/b^2]_0^b 1/EJ$$

$$= (1/3 b) 1/EJ = 1/3 b/EJ$$

$$L_{GA}^{xx} = \int_0^b (1/4 - 1/2 x/b + 1/4 x^2/b^2) 1/EJ dx = [1/4 x - 1/4 x^2/b + 1/12 x^3/b^2]_0^b 1/EJ$$

$$= (1/4 b - 1/4 b + 1/12 b) 1/EJ = 1/12 b/EJ$$

$$L_{AG}^{xx} = \int_0^b (1/4 x^2/b^2) 1/EJ dx = [1/12 x^3/b^2]_0^b 1/EJ$$

$$= (1/12 b) 1/EJ = 1/12 b/EJ$$

$$L_{FG}^{x_0} = \int_0^b (-1/2 x/b + 5/8 x^2/b^2) Fb 1/EJ dx + \int_0^b (1/2 x/b) \theta dx$$

$$= [-1/4 x^2/b + 5/24 x^3/b^2]_0^b Fb 1/EJ + [1/4 x^2/b]_0^b \theta$$

$$= (-1/4 b + 5/24 b) Fb 1/EJ + (1/4 b) \theta = 5/24 Fb^2/EJ$$

$$L_{GF}^{x_0} = \int_0^b (1/8 - 3/4 x/b + 5/8 x^2/b^2) Fb 1/EJ dx + \int_0^b (-1/2 + 1/2 x/b) \theta dx$$

$$= [1/8 x - 3/8 x^2/b + 5/24 x^3/b^2]_0^b Fb 1/EJ + [-1/2 x + 1/4 x^2/b]_0^b \theta$$

$$= (1/8 b - 3/8 b + 5/24 b) Fb 1/EJ + (-1/2 b + 1/4 b) \theta = 5/24 Fb^2/EJ$$

$$L_{GD}^{x_0} = \int_0^b (1/2 x/b - 1/2 x^3/b^3) Fb 1/EJ dx = [1/4 x^2/b - 1/8 x^4/b^3]_0^b Fb 1/EJ$$

$$= (1/4 b - 1/8 b) Fb 1/EJ = 1/8 Fb^2/EJ$$

$$L_{DG}^{x_0} = \int_0^b (x/b - 3/2 x^2/b^2 + 1/2 x^3/b^3) Fb 1/EJ dx = [1/2 x^2/b - 1/2 x^3/b^2 + 1/8 x^4/b^3]_0^b Fb 1/EJ$$

$$= (1/2 b - 1/2 b + 1/8 b) Fb 1/EJ = 1/8 Fb^2/EJ$$

$$L_{GA}^{x_0} = \int_0^b (-1/8 + 3/8 x^2/b^2 - 1/4 x^3/b^3) Fb 1/EJ dx = [-1/8 x + 1/8 x^3/b^2 - 1/16 x^4/b^3]_0^b Fb 1/EJ$$

$$= (-1/8 b + 1/8 b - 1/16 b) Fb 1/EJ = -1/16 Fb^2/EJ$$

$$L_{AG}^{x_0} = \int_0^b (-3/8 x^2/b^2 + 1/4 x^3/b^3) Fb 1/EJ dx = [-1/8 x^3/b^2 + 1/16 x^4/b^3]_0^b Fb 1/EJ$$

$$= (-1/8 b + 1/16 b) Fb 1/EJ = -1/16 Fb^2/EJ$$

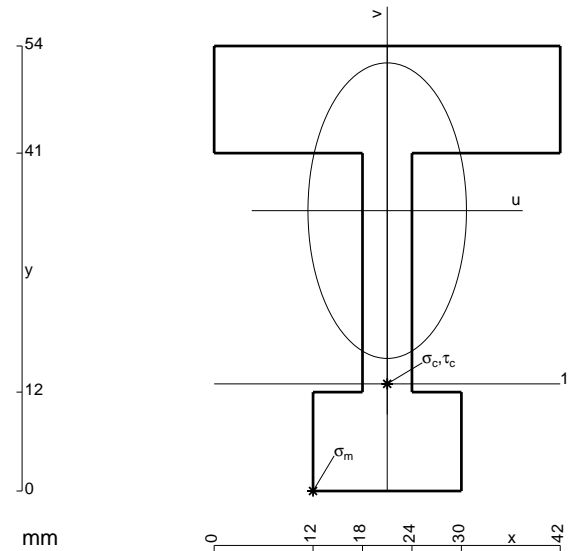

$$A = 936. \text{ mm}^2$$

$$J_u = 301116. \text{ mm}^4$$

$$J_v = 86616. \text{ mm}^4$$

$$y_g = 34.02 \text{ mm}$$

$$T_y = -2980. \text{ N}$$

$$M_x = -2115800. \text{ Nmm}$$

$$x_m = 12. \text{ mm}$$

$$u_m = -9. \text{ mm}$$

$$v_m = -34.02 \text{ mm}$$

$$\sigma_m = -Mv/J_u = -239. \text{ N/mm}^2$$

$$x_c = 21. \text{ mm}$$

$$y_c = 13. \text{ mm}$$

$$v_c = -21.02 \text{ mm}$$

$$\sigma_c = -Mv/J_u = -147.7 \text{ N/mm}^2$$

$$\tau_c = 10.2 \text{ N/mm}^2$$

$$\sigma_q = \sqrt{\sigma^2 + 3\tau^2} = 148.7 \text{ N/mm}^2$$

$$S = 6181. \text{ mm}^3$$

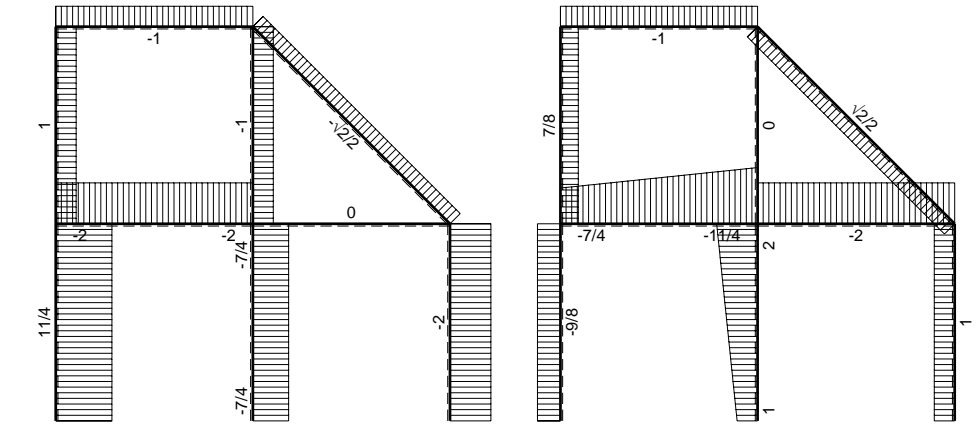
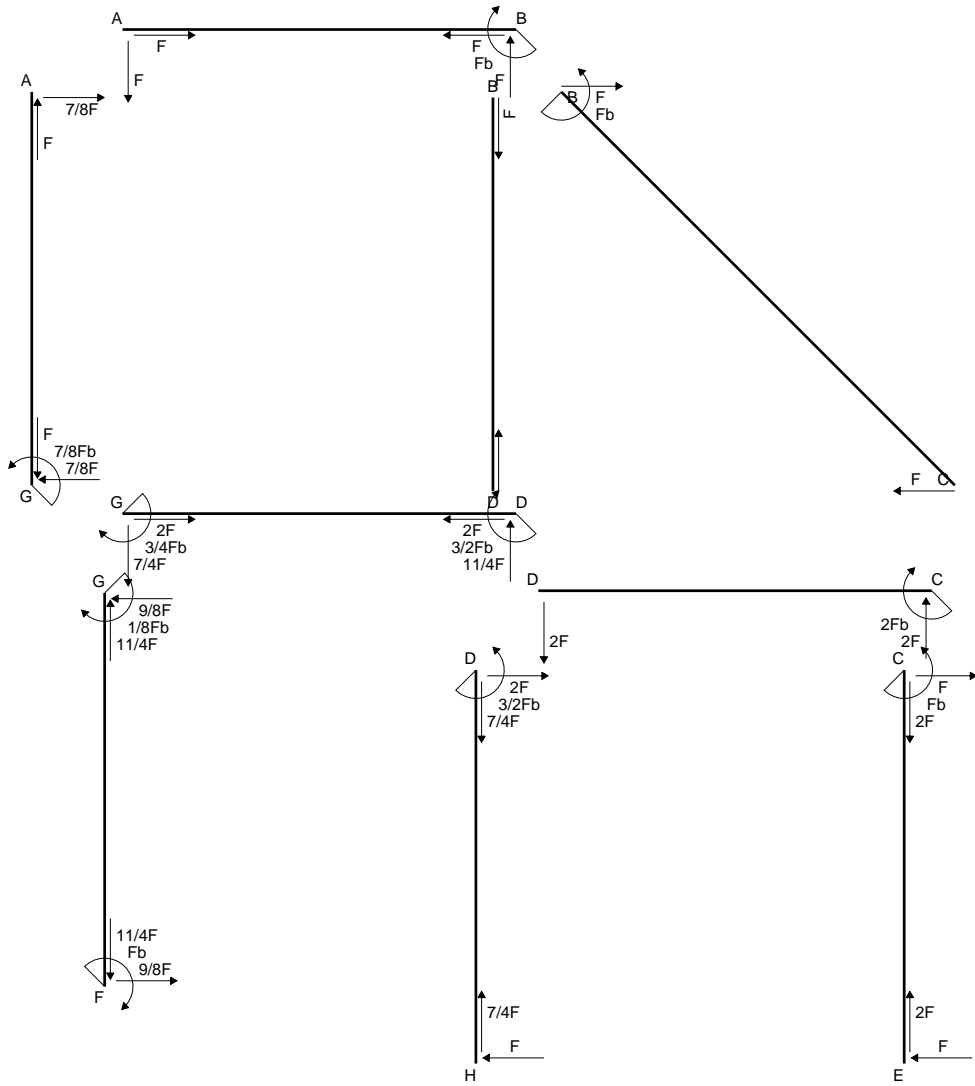

← ⊕ → F

↑ ⊕ ↓ F

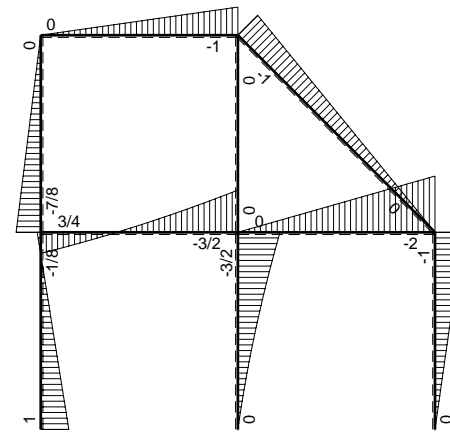

⊕ F_b

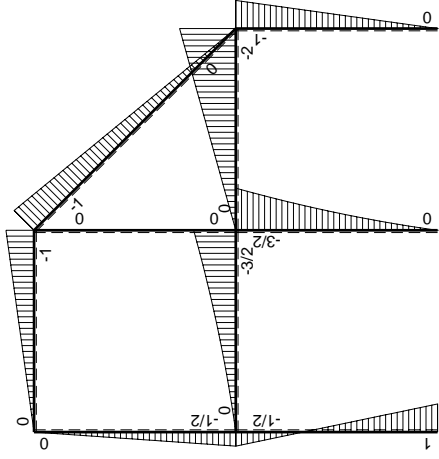
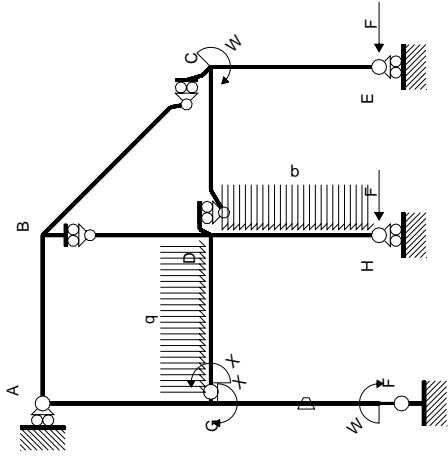

Schema di calcolo iperstatico

M_0 flessione da carichi assegnati

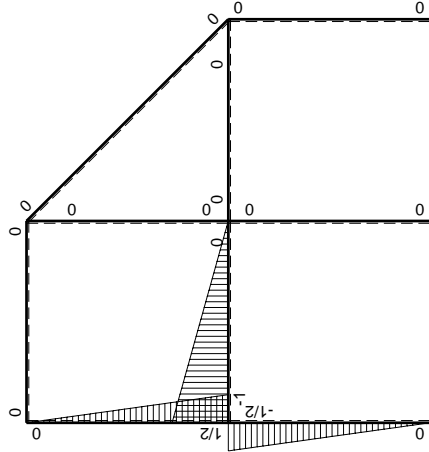

M_x flessione da iperstatica $X=1$

Quadro contributi PLV per iperstatica $X=W_{GD}$

→	$M_x(x)$	$M_o(x)$	θ	$M_x M_o$	$M_x \theta$	$M_x M_x$	$\int M_x(M_o/EJ+\theta)dx$	$\int X M_x M_x/EJdx$	
AB b	0	-Fx	0	0	0	0	0+0	0	
BA b	0	Fb-Fx	0	0	0	0	0	0	
BC $\sqrt{2}b$	0	-Fb+ $\sqrt{2}/2Fx$	0	0	0	0	0	0	
BD b	0	0	0	0	0	0	0+0	0	
DB b	0	0	0	0	0	0	0	0	
DC b	0	-2Fx	0	0	0	0	0+0	0	
CD b	0	2Fb-2Fx	0	0	0	0	0	0	
CE b	0	-Fb+Fx	0	0	0	0	0+0	0	
EC b	0	Fx	0	0	0	0	0	0	
FG b	-1/2x/b	Fb-3/2Fx	-Fb/EJ	-1/2Fx+3/4Fx ² /b	1/2Fx/EJ	1/4x ² /b ²	(0+1/4)Fb ² /EJ	1/12Xb/EJ	
GF b	1/2-1/2x/b	1/2Fb-3/2Fx	Fb/EJ	1/4Fb-Fx+3/4Fx ² /b	1/2Fb/EJ-1/2Fx/EJ	1/4-1/2x/b+1/4x ² /b ²			
GD b	-1+x/b	-Fx-1/2qx ²	0	Fx-1/2Fx ² /b-1/2qx ³ /b	0	1-2x/b+x ² /b ²	(5/24+0)Fb ² /EJ	1/3Xb/EJ	
DG b	x/b	3/2Fb-2Fx+1/2qx ²	0	3/2Fx-2Fx ² /b+1/2qx ³ /b	0	x ² /b ²			
DH b	0	-3/2Fb+2Fx-1/2qx ²	0	0	0	0	0+0	0	
HD b	0	Fx+1/2qx ²	0	0	0	0			
GA b	1/2-1/2x/b	-1/2Fb+1/2Fx	0	-1/4Fb+1/2Fx-1/4Fx ² /b	0	1/4-1/2x/b+1/4x ² /b ²	(-1/12+0)Fb ² /EJ	1/12Xb/EJ	
AG b	-1/2x/b	1/2Fx	0	-1/4Fx ² /b	0	1/4x ² /b ²			
	totali							3/8Fb ² /EJ	1/2Xb/EJ
	iperstatica $X=W_{GD}$							-3/4Fb	

Sviluppi di calcolo iperstatica

$$L_{FG}^{xx} = \int_0^b (1/4 x^2/b^2) 1/EJ dx = [1/12 x^3/b^2]_0^b 1/EJ$$

$$= (1/12 b) 1/EJ = 1/12 b/EJ$$

$$L_{GF}^{xx} = \int_0^b (1/4 - 1/2 x/b + 1/4 x^2/b^2) 1/EJ dx = [1/4 x - 1/4 x^2/b + 1/12 x^3/b^2]_0^b 1/EJ$$

$$= (1/4 b - 1/4 b + 1/12 b) 1/EJ = 1/12 b/EJ$$

$$L_{GD}^{xx} = \int_0^b (1 - 2 x/b + x^2/b^2) 1/EJ dx = [x - x^2/b + 1/3 x^3/b^2]_0^b 1/EJ$$

$$= (b - b + 1/3 b) 1/EJ = 1/3 b/EJ$$

$$L_{DG}^{xx} = \int_0^b (x^2/b^2) 1/EJ dx = [1/3 x^3/b^2]_0^b 1/EJ$$

$$= (1/3 b) 1/EJ = 1/3 b/EJ$$

$$L_{GA}^{xx} = \int_0^b (1/4 - 1/2 x/b + 1/4 x^2/b^2) 1/EJ dx = [1/4 x - 1/4 x^2/b + 1/12 x^3/b^2]_0^b 1/EJ$$

$$= (1/4 b - 1/4 b + 1/12 b) 1/EJ = 1/12 b/EJ$$

$$L_{AG}^{xx} = \int_0^b (1/4 x^2/b^2) 1/EJ dx = [1/12 x^3/b^2]_0^b 1/EJ$$

$$= (1/12 b) 1/EJ = 1/12 b/EJ$$

$$L_{FG}^{xo} = \int_0^b (-1/2 x/b + 3/4 x^2/b^2) Fb 1/EJ dx + \int_0^b (1/2 x/b) \theta dx$$

$$= [-1/4 x^2/b + 1/4 x^3/b^2]_0^b Fb 1/EJ + [1/4 x^2/b]_0^b \theta$$

$$= (-1/4 b + 1/4 b) Fb 1/EJ + (1/4 b) \theta = 1/4 Fb^2/EJ$$

$$L_{GF}^{xo} = \int_0^b (1/4 - x/b + 3/4 x^2/b^2) Fb 1/EJ dx + \int_0^b (-1/2 + 1/2 x/b) \theta dx$$

$$= [1/4 x - 1/2 x^2/b + 1/4 x^3/b^2]_0^b Fb 1/EJ + [-1/2 x + 1/4 x^2/b]_0^b \theta$$

$$= (1/4 b - 1/2 b + 1/4 b) Fb 1/EJ + (-1/2 b + 1/4 b) \theta = 1/4 Fb^2/EJ$$

$$L_{GD}^{xo} = \int_0^b (x/b - 1/2 x^2/b^2 - 1/2 x^3/b^3) Fb 1/EJ dx = [1/2 x^2/b - 1/6 x^3/b^2 - 1/8 x^4/b^3]_0^b Fb 1/EJ$$

$$= (1/2 b - 1/6 b - 1/8 b) Fb 1/EJ = 5/24 Fb^2/EJ$$

$$L_{DG}^{xo} = \int_0^b (3/2 x/b - 2 x^2/b^2 + 1/2 x^3/b^3) Fb 1/EJ dx = [3/4 x^2/b - 2/3 x^3/b^2 + 1/8 x^4/b^3]_0^b Fb 1/EJ$$

$$= (3/4 b - 2/3 b + 1/8 b) Fb 1/EJ = 5/24 Fb^2/EJ$$

$$L_{GA}^{xo} = \int_0^b (-1/4 + 1/2 x/b - 1/4 x^2/b^2) Fb 1/EJ dx = [-1/4 x + 1/4 x^2/b - 1/12 x^3/b^2]_0^b Fb 1/EJ$$

$$= (-1/4 b + 1/4 b - 1/12 b) Fb 1/EJ = -1/12 Fb^2/EJ$$

$$L_{AG}^{xo} = \int_0^b (-1/4 x^2/b^2) Fb 1/EJ dx = [-1/12 x^3/b^2]_0^b Fb 1/EJ$$

$$= (-1/12 b) Fb 1/EJ = -1/12 Fb^2/EJ$$

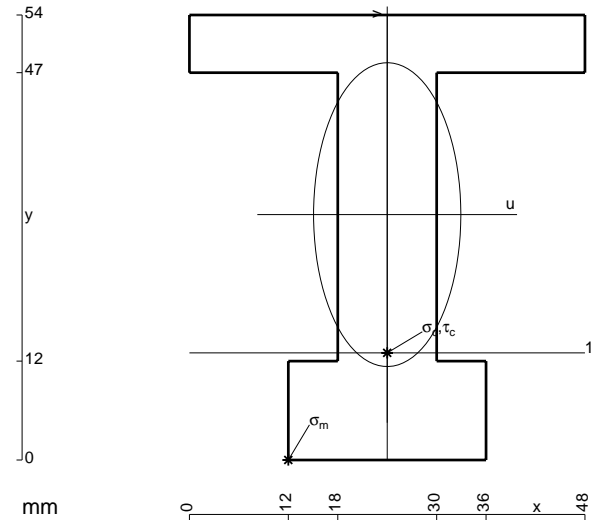

- A = 1044. mm²
- J_u = 354848. mm⁴
- J_v = 83376. mm⁴
- y_g = 29.78 mm
- T_y = -3120. N
- M_x = -2371200. Nmm
- x_m = 12. mm
- u_m = -12. mm
- v_m = -29.78 mm
- σ_m = -Mv/J_u = -199. N/mm²
- x_c = 24. mm
- y_c = 13. mm
- v_c = -16.78 mm
- σ_c = -Mv/J_u = -112.1 N/mm²
- τ_c = 5.169 N/mm²
- σ_q = √σ²+3τ² = 112.5 N/mm²
- S = 7055. mm³

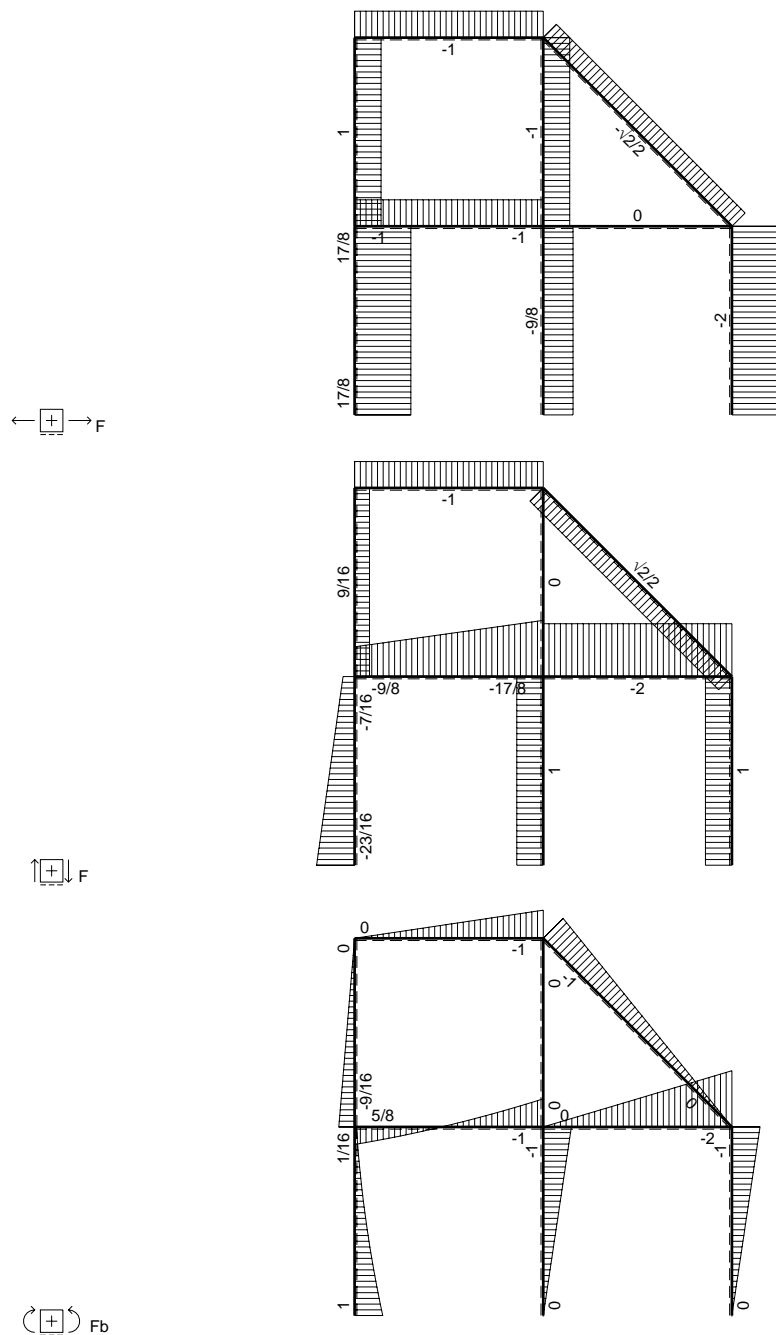
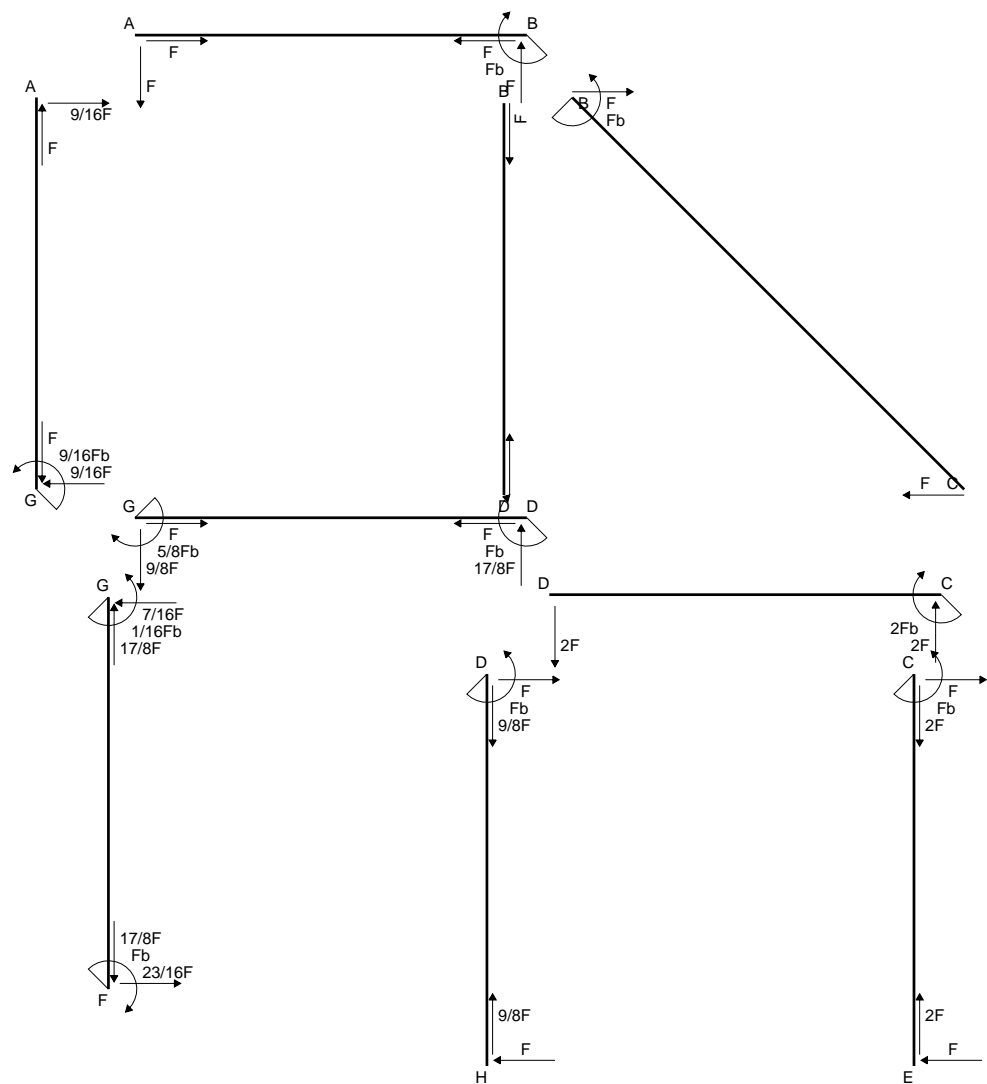

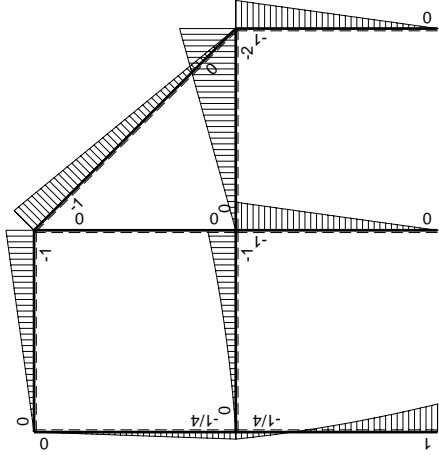
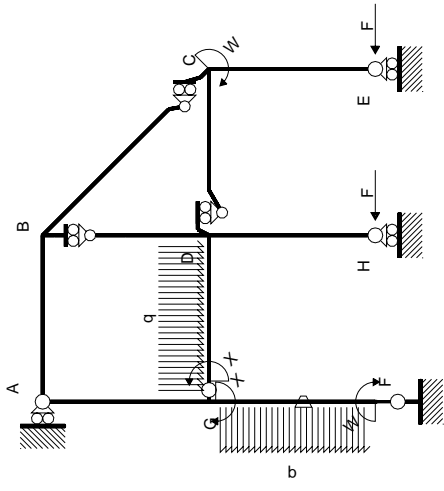

Schema di calcolo iperstatico

M_0 flessione da carichi assegnati



M_x flessione da iperstatica $X=1$

Quadro contributi PLV per iperstatica $X=W_{GD}$

→	$M_x(x)$	$M_o(x)$	θ	$M_x M_o$	$M_x \theta$	$M_x M_x$	$\int M_x(M_o/EJ+\theta)dx$	$\int X M_x M_x/EJ dx$	
AB b	0	-Fx	0	0	0	0	0+0	0	
BA b	0	Fb-Fx	0	0	0	0	0	0	
BC $\sqrt{2}b$	0	-Fb+ $\sqrt{2}/2Fx$	0	0	0	0	0	0	
BD b	0	0	0	0	0	0	0+0	0	
DB b	0	0	0	0	0	0	0	0	
DC b	0	-2Fx	0	0	0	0	0+0	0	
CD b	0	2Fb-2Fx	0	0	0	0	0	0	
CE b	0	-Fb+Fx	0	0	0	0	0+0	0	
EC b	0	Fx	0	0	0	0	0	0	
FG b	-1/2x/b	Fb-7/4Fx+1/2qx ²	-Fb/EJ	-1/2Fx+7/8Fx ² /b-1/4qx ³ /b	1/2Fx/EJ	1/4x ² /b ²	(-1/48+1/4)Fb ² /EJ	1/12Xb/EJ	
GF b	1/2-1/2x/b	1/4Fb-3/4Fx-1/2qx ²	Fb/EJ	1/8Fb-1/2Fx+1/8Fx ² /b+1/4qx ³ /b	1/2Fb/EJ-1/2Fx/EJ	1/4-1/2x/b+1/4x ² /b ²			
GD b	-1+x/b	-1/2Fx-1/2qx ²	0	1/2Fx-1/2qx ³ /b	0	1-2x/b+x ² /b ²	(1/8+0)Fb ² /EJ	1/3Xb/EJ	
DG b	x/b	Fb-3/2Fx+1/2qx ²	0	Fx-3/2Fx ² /b+1/2qx ³ /b	0	x ² /b ²			
DH b	0	-Fb+Fx	0	0	0	0	0+0	0	
HD b	0	Fx	0	0	0	0	0	0	
GA b	1/2-1/2x/b	-1/4Fb+1/4Fx	0	-1/8Fb+1/4Fx-1/8Fx ² /b	0	1/4-1/2x/b+1/4x ² /b ²	(-1/24+0)Fb ² /EJ	1/12Xb/EJ	
AG b	-1/2x/b	1/4Fx	0	-1/8Fx ² /b	0	1/4x ² /b ²			
	totali							5/16Fb ² /EJ	1/2Xb/EJ
	iperstatica $X=W_{GD}$							-5/8Fb	

Sviluppi di calcolo iperstatica

$$L_{FG}^{xx} = \int_0^b (1/4 x^2/b^2) 1/EJ dx = [1/12 x^3/b^2]_0^b 1/EJ$$

$$= (1/12 b) 1/EJ = 1/12 b/EJ$$

$$L_{GF}^{xx} = \int_0^b (1/4 -1/2 x/b +1/4 x^2/b^2) 1/EJ dx = [1/4 x -1/4 x^2/b +1/12 x^3/b^2]_0^b 1/EJ$$

$$= (1/4 b -1/4 b +1/12 b) 1/EJ = 1/12 b/EJ$$

$$L_{GD}^{xx} = \int_0^b (1 -2 x/b + x^2/b^2) 1/EJ dx = [x - x^2/b +1/3 x^3/b^2]_0^b 1/EJ$$

$$= (b - b +1/3 b) 1/EJ = 1/3 b/EJ$$

$$L_{DG}^{xx} = \int_0^b (x^2/b^2) 1/EJ dx = [1/3 x^3/b^2]_0^b 1/EJ$$

$$= (1/3 b) 1/EJ = 1/3 b/EJ$$

$$L_{GA}^{xx} = \int_0^b (1/4 -1/2 x/b +1/4 x^2/b^2) 1/EJ dx = [1/4 x -1/4 x^2/b +1/12 x^3/b^2]_0^b 1/EJ$$

$$= (1/4 b -1/4 b +1/12 b) 1/EJ = 1/12 b/EJ$$

$$L_{AG}^{xx} = \int_0^b (1/4 x^2/b^2) 1/EJ dx = [1/12 x^3/b^2]_0^b 1/EJ$$

$$= (1/12 b) 1/EJ = 1/12 b/EJ$$

$$L_{FG}^{xo} = \int_0^b (-1/2 x/b +7/8 x^2/b^2 -1/4 x^3/b^3) Fb 1/EJ dx + \int_0^b (1/2 x/b) \theta dx$$

$$= [-1/4 x^2/b +7/24 x^3/b^2 -1/16 x^4/b^3]_0^b Fb 1/EJ + [1/4 x^2/b]_0^b \theta$$

$$= (-1/4 b +7/24 b -1/16 b) Fb 1/EJ + (1/4 b) \theta = 11/48 Fb^2/EJ$$

$$L_{GF}^{xo} = \int_0^b (1/8 -1/2 x/b +1/8 x^2/b^2 +1/4 x^3/b^3) Fb 1/EJ dx + \int_0^b (-1/2 +1/2 x/b) \theta dx$$

$$= [1/8 x -1/4 x^2/b +1/24 x^3/b^2 +1/16 x^4/b^3]_0^b Fb 1/EJ + [-1/2 x +1/4 x^2/b]_0^b \theta$$

$$= (1/8 b -1/4 b +1/24 b +1/16 b) Fb 1/EJ + (-1/2 b +1/4 b) \theta = 11/48 Fb^2/EJ$$

$$L_{GD}^{xo} = \int_0^b (1/2 x/b -1/2 x^3/b^3) Fb 1/EJ dx = [1/4 x^2/b -1/8 x^4/b^3]_0^b Fb 1/EJ$$

$$= (1/4 b -1/8 b) Fb 1/EJ = 1/8 Fb^2/EJ$$

$$L_{DG}^{xo} = \int_0^b (x/b -3/2 x^2/b^2 +1/2 x^3/b^3) Fb 1/EJ dx = [1/2 x^2/b -1/2 x^3/b^2 +1/8 x^4/b^3]_0^b Fb 1/EJ$$

$$= (1/2 b -1/2 b +1/8 b) Fb 1/EJ = 1/8 Fb^2/EJ$$

$$L_{GA}^{xo} = \int_0^b (-1/8 +1/4 x/b -1/8 x^2/b^2) Fb 1/EJ dx = [-1/8 x +1/8 x^2/b -1/24 x^3/b^2]_0^b Fb 1/EJ$$

$$= (-1/8 b +1/8 b -1/24 b) Fb 1/EJ = -1/24 Fb^2/EJ$$

$$L_{AG}^{xo} = \int_0^b (-1/8 x^2/b^2) Fb 1/EJ dx = [-1/24 x^3/b^2]_0^b Fb 1/EJ$$

$$= (-1/24 b) Fb 1/EJ = -1/24 Fb^2/EJ$$

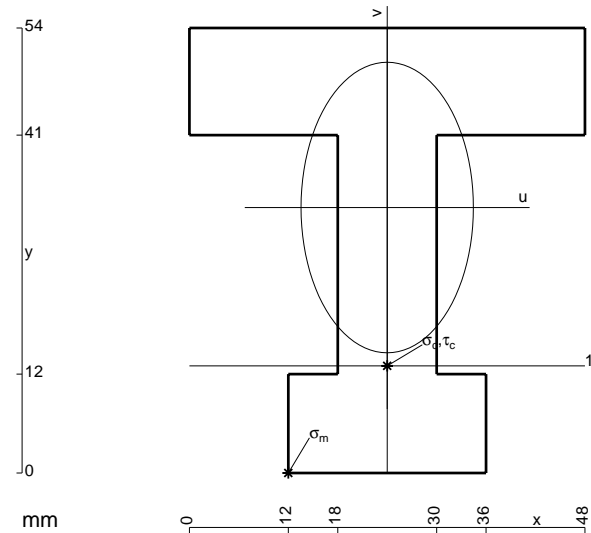

- A = 1260. mm²
- J_u = 391706. mm⁴
- J_v = 137808. mm⁴
- y_g = 32.21 mm
- T_y = -3140. N
- M_x = -2543400. Nmm
- x_m = 12. mm
- u_m = -12. mm
- v_m = -32.21 mm
- σ_m = -Mv/J_u = -209.2 N/mm²
- x_c = 24. mm
- y_c = 13. mm
- v_c = -19.21 mm
- σ_c = -Mv/J_u = -124.8 N/mm²
- τ_c = 5.201 N/mm²
- σ_q = √σ²+3τ² = 125.1 N/mm²
- S = 7786. mm³

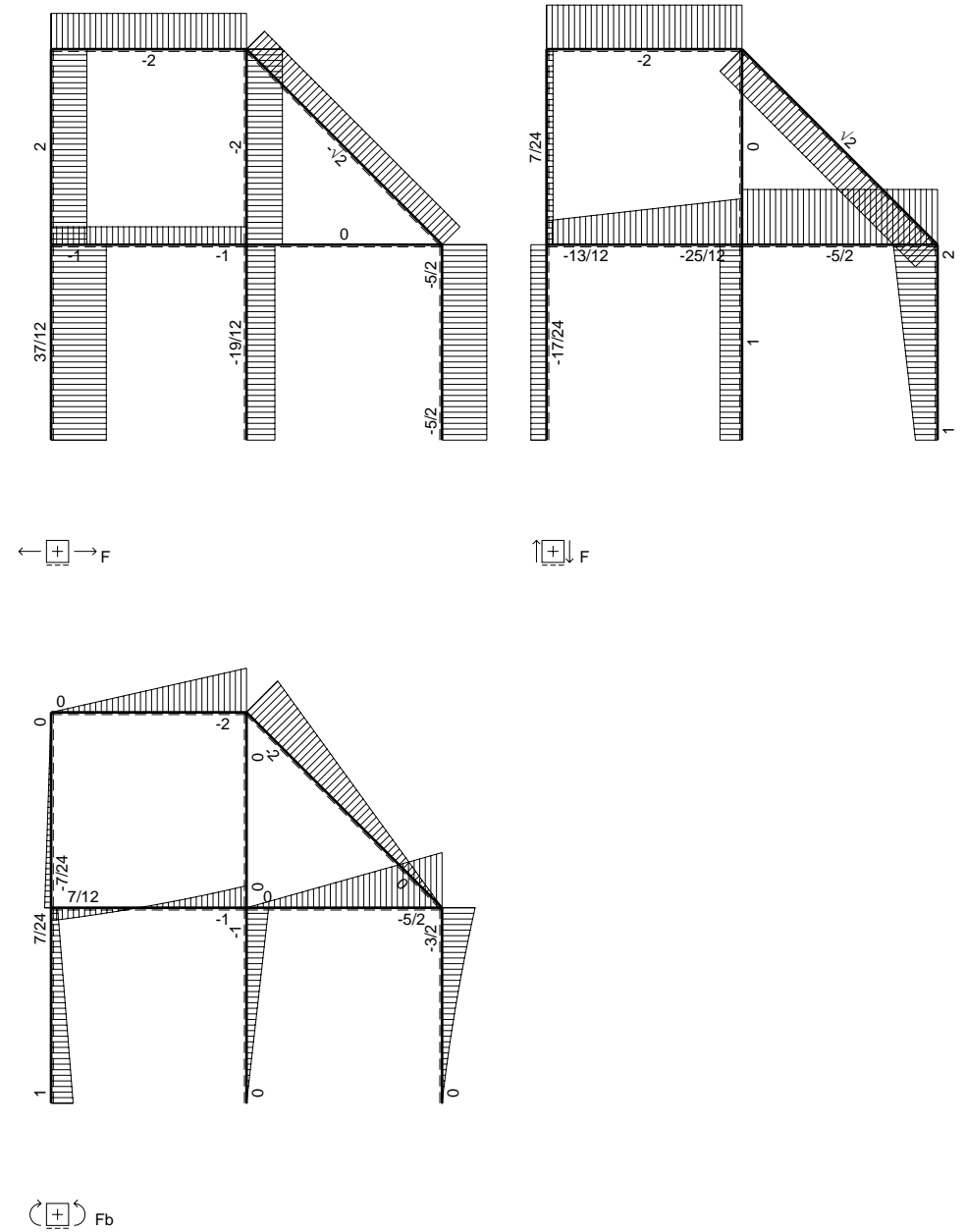
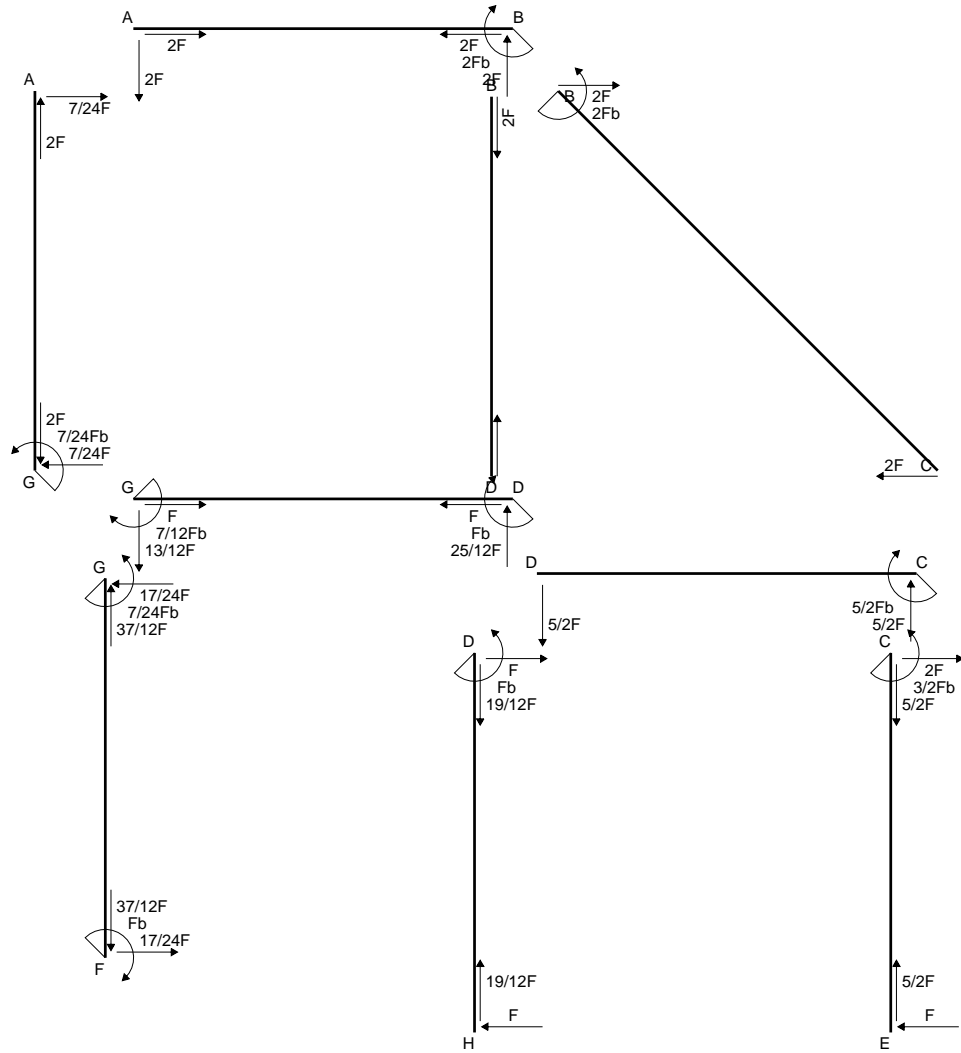

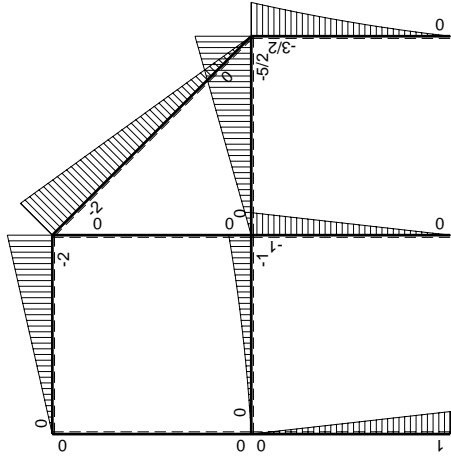
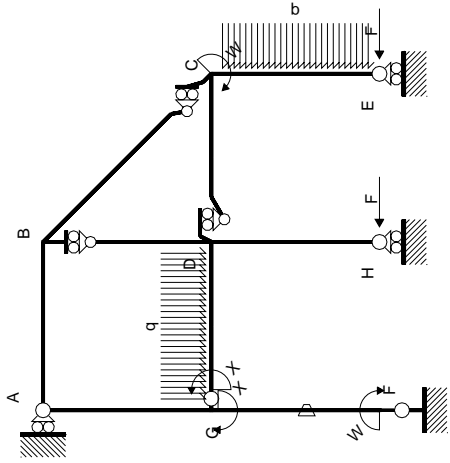

Schema di calcolo iperstatico

M_0 flessione da carichi assegnati

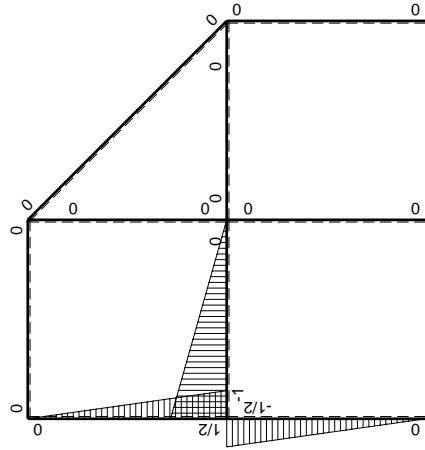

M_x flessione da iperstatica $X=1$

Quadro contributi PLV per iperstatica $X=W_{GD}$

→	$M_x(x)$	$M_o(x)$	θ	$M_x M_o$	$M_x \theta$	$M_x M_x$	$\int M_x(M_o/EJ+\theta)dx$	$\int X M_x M_x/EJdx$	
AB b	0	-2Fx	0	0	0	0	0+0	0	
BA b	0	2Fb-2Fx	0	0	0	0			
BC $\sqrt{2}b$	0	-2Fb+ $\sqrt{2}Fx$	0	0	0	0	0	0	
BD b	0	0	0	0	0	0	0+0	0	
DB b	0	0	0	0	0	0			
DC b	0	-5/2Fx	0	0	0	0	0+0	0	
CD b	0	5/2Fb-5/2Fx	0	0	0	0			
CE b	0	-3/2Fb+2Fx-1/2qx ²	0	0	0	0	0+0	0	
EC b	0	Fx+1/2qx ²	0	0	0	0			
FG b	-1/2x/b	Fb-Fx	-Fb/EJ	-1/2Fx+1/2Fx ² /b	1/2Fx/EJ	1/4x ² /b ²	(-1/12+1/4)Fb ² /EJ	1/12Xb/EJ	
GF b	1/2-1/2x/b	-Fx	Fb/EJ	-1/2Fx+1/2Fx ² /b	1/2Fb/EJ-1/2Fx/EJ	1/4-1/2x/b+1/4x ² /b ²			
GD b	-1+x/b	-1/2Fx-1/2qx ²	0	1/2Fx-1/2qx ³ /b	0	1-2x/b+x ² /b ²	(1/8+0)Fb ² /EJ	1/3Xb/EJ	
DG b	x/b	Fb-3/2Fx+1/2qx ²	0	Fx-3/2Fx ² /b+1/2qx ³ /b	0	x ² /b ²			
DH b	0	-Fb+Fx	0	0	0	0	0+0	0	
HD b	0	Fx	0	0	0	0			
GA b	1/2-1/2x/b	0	0	0	0	1/4-1/2x/b+1/4x ² /b ²	0+0	1/12Xb/EJ	
AG b	-1/2x/b	0	0	0	0	1/4x ² /b ²			
	totali							7/24Fb ² /EJ	1/2Xb/EJ
	iperstatica $X=W_{GD}$							-7/12Fb	

Sviluppi di calcolo iperstatica

$$L_{FG}^{xx} = \int_0^b (1/4 x^2/b^2) 1/EJ dx = [1/12 x^3/b^2]_0^b 1/EJ$$

$$= (1/12 b) 1/EJ = 1/12 b/EJ$$

$$L_{GF}^{xx} = \int_0^b (1/4 - 1/2 x/b + 1/4 x^2/b^2) 1/EJ dx = [1/4 x - 1/4 x^2/b + 1/12 x^3/b^2]_0^b 1/EJ$$

$$= (1/4 b - 1/4 b + 1/12 b) 1/EJ = 1/12 b/EJ$$

$$L_{GD}^{xx} = \int_0^b (1 - 2 x/b + x^2/b^2) 1/EJ dx = [x - x^2/b + 1/3 x^3/b^2]_0^b 1/EJ$$

$$= (b - b + 1/3 b) 1/EJ = 1/3 b/EJ$$

$$L_{DG}^{xx} = \int_0^b (x^2/b^2) 1/EJ dx = [1/3 x^3/b^2]_0^b 1/EJ$$

$$= (1/3 b) 1/EJ = 1/3 b/EJ$$

$$L_{GA}^{xx} = \int_0^b (1/4 - 1/2 x/b + 1/4 x^2/b^2) 1/EJ dx = [1/4 x - 1/4 x^2/b + 1/12 x^3/b^2]_0^b 1/EJ$$

$$= (1/4 b - 1/4 b + 1/12 b) 1/EJ = 1/12 b/EJ$$

$$L_{AG}^{xx} = \int_0^b (1/4 x^2/b^2) 1/EJ dx = [1/12 x^3/b^2]_0^b 1/EJ$$

$$= (1/12 b) 1/EJ = 1/12 b/EJ$$

$$L_{FG}^{xo} = \int_0^b (-1/2 x/b + 1/2 x^2/b^2) Fb 1/EJ dx + \int_0^b (1/2 x/b) \theta dx$$

$$= [-1/4 x^2/b + 1/6 x^3/b^2]_0^b Fb 1/EJ + [1/4 x^2/b]_0^b \theta$$

$$= (-1/4 b + 1/6 b) Fb 1/EJ + (1/4 b) \theta = 1/6 Fb^2/EJ$$

$$L_{GF}^{xo} = \int_0^b (-1/2 x/b + 1/2 x^2/b^2) Fb 1/EJ dx + \int_0^b (-1/2 + 1/2 x/b) \theta dx$$

$$= [-1/4 x^2/b + 1/6 x^3/b^2]_0^b Fb 1/EJ + [-1/2 x + 1/4 x^2/b]_0^b \theta$$

$$= (-1/4 b + 1/6 b) Fb 1/EJ + (-1/2 b + 1/4 b) \theta = 1/6 Fb^2/EJ$$

$$L_{GD}^{xo} = \int_0^b (1/2 x/b - 1/2 x^3/b^3) Fb 1/EJ dx = [1/4 x^2/b - 1/8 x^4/b^3]_0^b Fb 1/EJ$$

$$= (1/4 b - 1/8 b) Fb 1/EJ = 1/8 Fb^2/EJ$$

$$L_{DG}^{xo} = \int_0^b (x/b - 3/2 x^2/b^2 + 1/2 x^3/b^3) Fb 1/EJ dx = [1/2 x^2/b - 1/2 x^3/b^2 + 1/8 x^4/b^3]_0^b Fb 1/EJ$$

$$= (1/2 b - 1/2 b + 1/8 b) Fb 1/EJ = 1/8 Fb^2/EJ$$

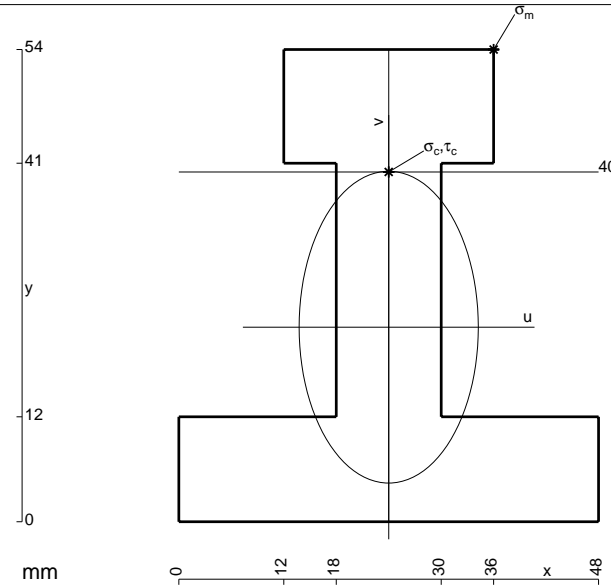

- A = 1236. mm²
- J_u = 393000. mm⁴
- J_v = 129744. mm⁴
- y_g = 22.25 mm
- T_y = -3150. N
- M_x = -2709000. Nmm
- x_m = 36. mm
- y_m = 54. mm
- u_m = 12. mm
- v_m = 31.75 mm
- σ_m = -Mv/J_u = 218.9 N/mm²
- x_c = 24. mm
- y_c = 40. mm
- v_c = 17.75 mm
- σ_c = -Mv/J_u = 122.4 N/mm²
- τ_c = 5.409 N/mm²
- σ_q = √σ²+3τ² = 122.7 N/mm²
- S = 8098. mm³

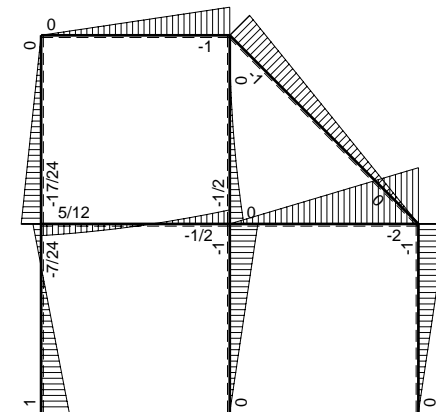
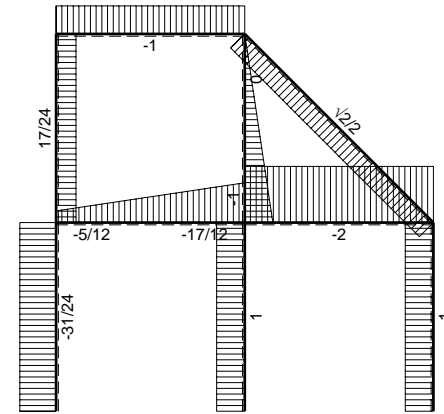
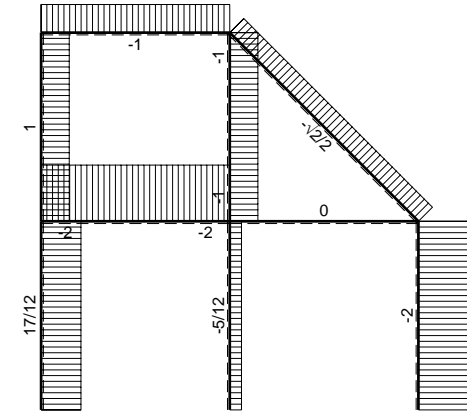
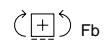
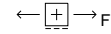
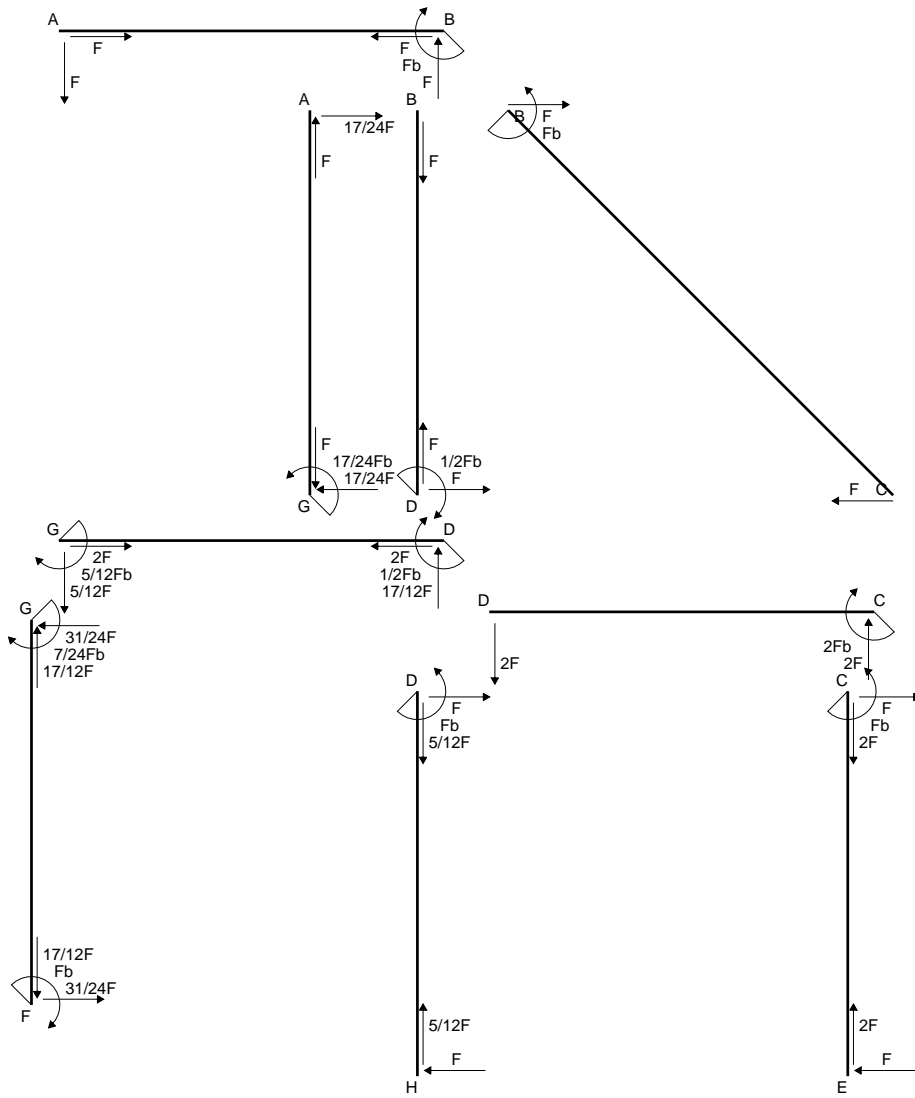

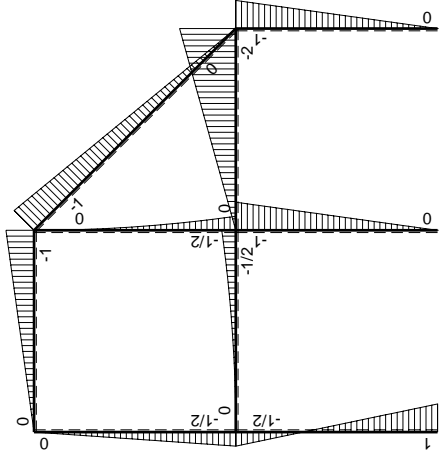
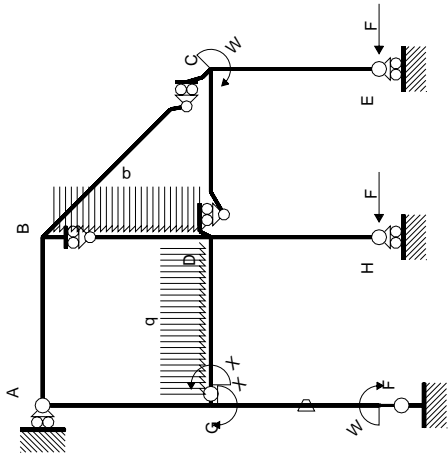

Schema di calcolo iperstatico

M_0 flessione da carichi assegnati

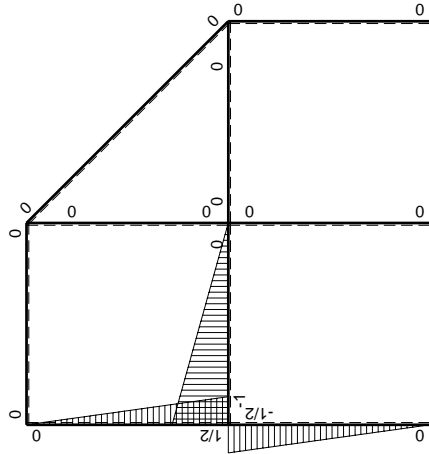

M_x flessione da iperstatica $X=1$

Quadro contributi PLV per iperstatica $X=W_{GD}$

→	$M_x(x)$	$M_o(x)$	θ	$M_x M_o$	$M_x \theta$	$M_x M_x$	$\int M_x(M_o/EJ+\theta)dx$	$\int X M_x M_x/EJ dx$
AB b	0	-Fx	0	0	0	0	0+0	0
BA b	0	Fb-Fx	0	0	0	0		
BC $\sqrt{2}b$	0	-Fb+ $\sqrt{2}/2Fx$	0	0	0	0	0	0
BD b	0	-1/2qx ²	0	0	0	0	0+0	0
DB b	0	1/2Fb-Fx+1/2qx ²	0	0	0	0		
DC b	0	-2Fx	0	0	0	0	0+0	0
CD b	0	2Fb-2Fx	0	0	0	0		
CE b	0	-Fb+Fx	0	0	0	0	0+0	0
EC b	0	Fx	0	0	0	0		
FG b	-1/2x/b	Fb-3/2Fx	-Fb/EJ	-1/2Fx+3/4Fx ² /b	1/2Fx/EJ	1/4x ² /b ²	(0+1/4)Fb ² /EJ	1/12Xb/EJ
GF b	1/2-1/2x/b	1/2Fb-3/2Fx	Fb/EJ	1/4Fb-Fx+3/4Fx ² /b	1/2Fb/EJ-1/2Fx/EJ	1/4-1/2x/b+1/4x ² /b ²		
GD b	-1+x/b	-1/2qx ²	0	1/2Fx ² /b-1/2qx ³ /b	0	1-2x/b+x ² /b ²	(1/24+0)Fb ² /EJ	1/3Xb/EJ
DG b	x/b	1/2Fb-Fx+1/2qx ²	0	1/2Fx-Fx ² /b+1/2qx ³ /b	0	x ² /b ²		
DH b	0	-Fb+Fx	0	0	0	0	0+0	0
HD b	0	Fx	0	0	0	0		
GA b	1/2-1/2x/b	-1/2Fb+1/2Fx	0	-1/4Fb+1/2Fx-1/4Fx ² /b	0	1/4-1/2x/b+1/4x ² /b ²	(-1/12+0)Fb ² /EJ	1/12Xb/EJ
AG b	-1/2x/b	1/2Fx	0	-1/4Fx ² /b	0	1/4x ² /b ²		
	totali						5/24Fb ² /EJ	1/2Xb/EJ
	iperstatica $X=W_{GD}$						-5/12Fb	

Sviluppi di calcolo iperstatica

$$L_{FG}^{xx} = \int_0^b (1/4 x^2/b^2) 1/EJ dx = [1/12 x^3/b^2]_0^b 1/EJ$$

$$= (1/12 b) 1/EJ = 1/12 b/EJ$$

$$L_{GF}^{xx} = \int_0^b (1/4 - 1/2 x/b + 1/4 x^2/b^2) 1/EJ dx = [1/4 x - 1/4 x^2/b + 1/12 x^3/b^2]_0^b 1/EJ$$

$$= (1/4 b - 1/4 b + 1/12 b) 1/EJ = 1/12 b/EJ$$

$$L_{GD}^{xx} = \int_0^b (1 - 2 x/b + x^2/b^2) 1/EJ dx = [x - x^2/b + 1/3 x^3/b^2]_0^b 1/EJ$$

$$= (b - b + 1/3 b) 1/EJ = 1/3 b/EJ$$

$$L_{DG}^{xx} = \int_0^b (x^2/b^2) 1/EJ dx = [1/3 x^3/b^2]_0^b 1/EJ$$

$$= (1/3 b) 1/EJ = 1/3 b/EJ$$

$$L_{GA}^{xx} = \int_0^b (1/4 - 1/2 x/b + 1/4 x^2/b^2) 1/EJ dx = [1/4 x - 1/4 x^2/b + 1/12 x^3/b^2]_0^b 1/EJ$$

$$= (1/4 b - 1/4 b + 1/12 b) 1/EJ = 1/12 b/EJ$$

$$L_{AG}^{xx} = \int_0^b (1/4 x^2/b^2) 1/EJ dx = [1/12 x^3/b^2]_0^b 1/EJ$$

$$= (1/12 b) 1/EJ = 1/12 b/EJ$$

$$L_{FG}^{xo} = \int_0^b (-1/2 x/b + 3/4 x^2/b^2) Fb 1/EJ dx + \int_0^b (1/2 x/b) \theta dx$$

$$= [-1/4 x^2/b + 1/4 x^3/b^2]_0^b Fb 1/EJ + [1/4 x^2/b]_0^b \theta$$

$$= (-1/4 b + 1/4 b) Fb 1/EJ + (1/4 b) \theta = 1/4 Fb^2/EJ$$

$$L_{GF}^{xo} = \int_0^b (1/4 - x/b + 3/4 x^2/b^2) Fb 1/EJ dx + \int_0^b (-1/2 + 1/2 x/b) \theta dx$$

$$= [1/4 x - 1/2 x^2/b + 1/4 x^3/b^2]_0^b Fb 1/EJ + [-1/2 x + 1/4 x^2/b]_0^b \theta$$

$$= (1/4 b - 1/2 b + 1/4 b) Fb 1/EJ + (-1/2 b + 1/4 b) \theta = 1/4 Fb^2/EJ$$

$$L_{GD}^{xo} = \int_0^b (1/2 x^2/b^2 - 1/2 x^3/b^3) Fb 1/EJ dx = [1/6 x^3/b^2 - 1/8 x^4/b^3]_0^b Fb 1/EJ$$

$$= (1/6 b - 1/8 b) Fb 1/EJ = 1/24 Fb^2/EJ$$

$$L_{DG}^{xo} = \int_0^b (1/2 x/b - x^2/b^2 + 1/2 x^3/b^3) Fb 1/EJ dx = [1/4 x^2/b - 1/3 x^3/b^2 + 1/8 x^4/b^3]_0^b Fb 1/EJ$$

$$= (1/4 b - 1/3 b + 1/8 b) Fb 1/EJ = 1/24 Fb^2/EJ$$

$$L_{GA}^{xo} = \int_0^b (-1/4 + 1/2 x/b - 1/4 x^2/b^2) Fb 1/EJ dx = [-1/4 x + 1/4 x^2/b - 1/12 x^3/b^2]_0^b Fb 1/EJ$$

$$= (-1/4 b + 1/4 b - 1/12 b) Fb 1/EJ = -1/12 Fb^2/EJ$$

$$L_{AG}^{xo} = \int_0^b (-1/4 x^2/b^2) Fb 1/EJ dx = [-1/12 x^3/b^2]_0^b Fb 1/EJ$$

$$= (-1/12 b) Fb 1/EJ = -1/12 Fb^2/EJ$$

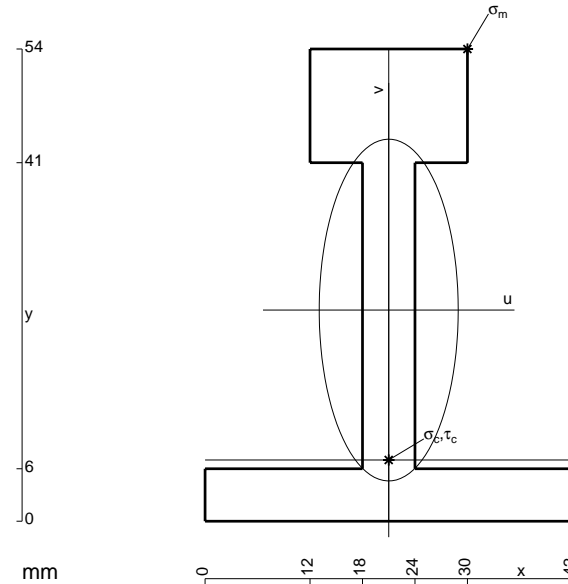

- A = 696. mm²
- J_u = 265885. mm⁴
- J_v = 43992. mm⁴
- y_g = 24.15 mm
- T_y = -2240. N
- M_x = -2038400. Nmm
- x_m = 30. mm
- y_m = 54. mm
- u_m = 9. mm
- v_m = 29.85 mm
- σ_m = -Mv/J_u = 228.9 N/mm²
- x_c = 21. mm
- y_c = 7. mm
- v_c = -17.15 mm
- σ_c = -Mv/J_u = -131.5 N/mm²
- τ_c = 7.631 N/mm²
- σ_o = √σ²+3τ² = 132.1 N/mm²
- S = 5435. mm³

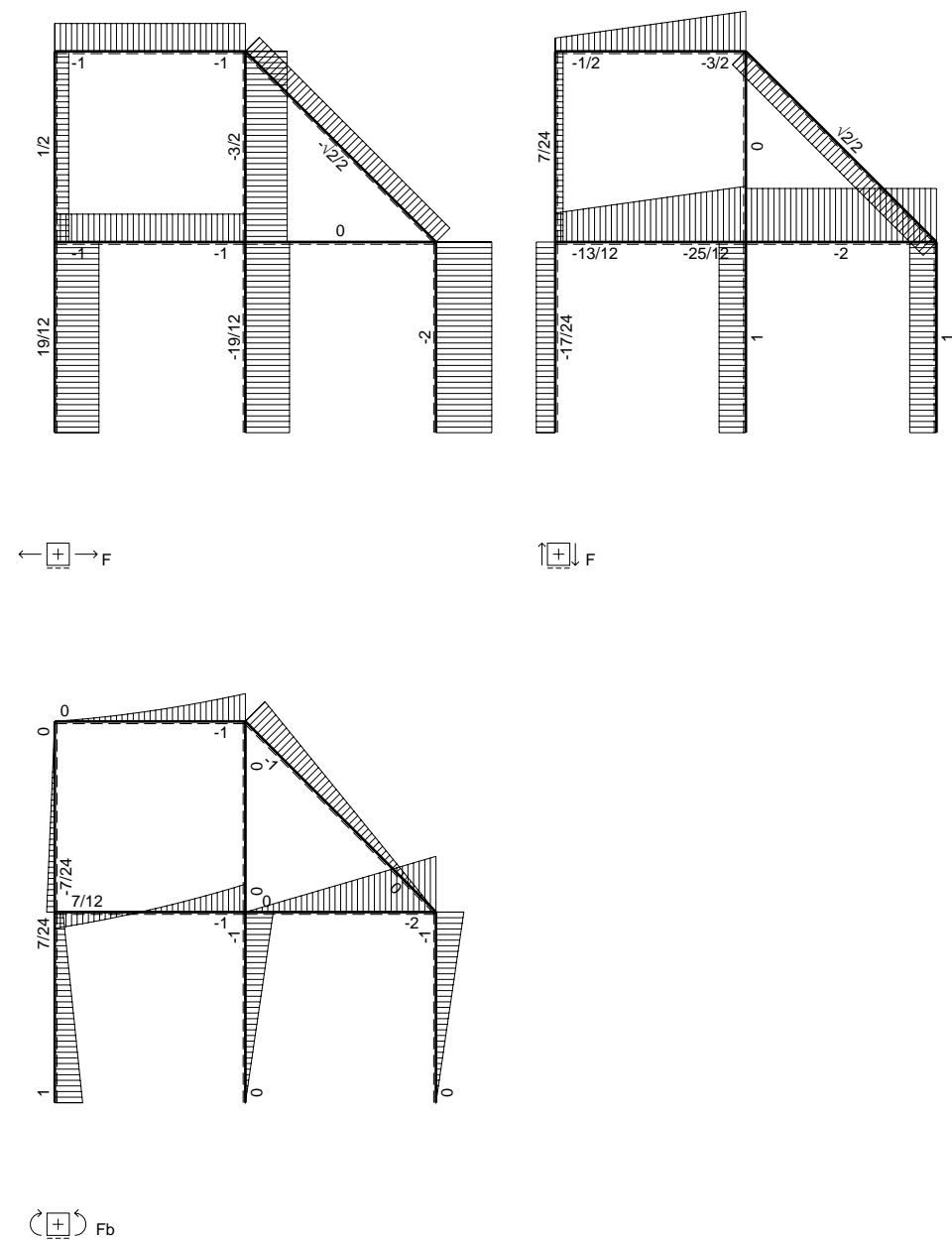
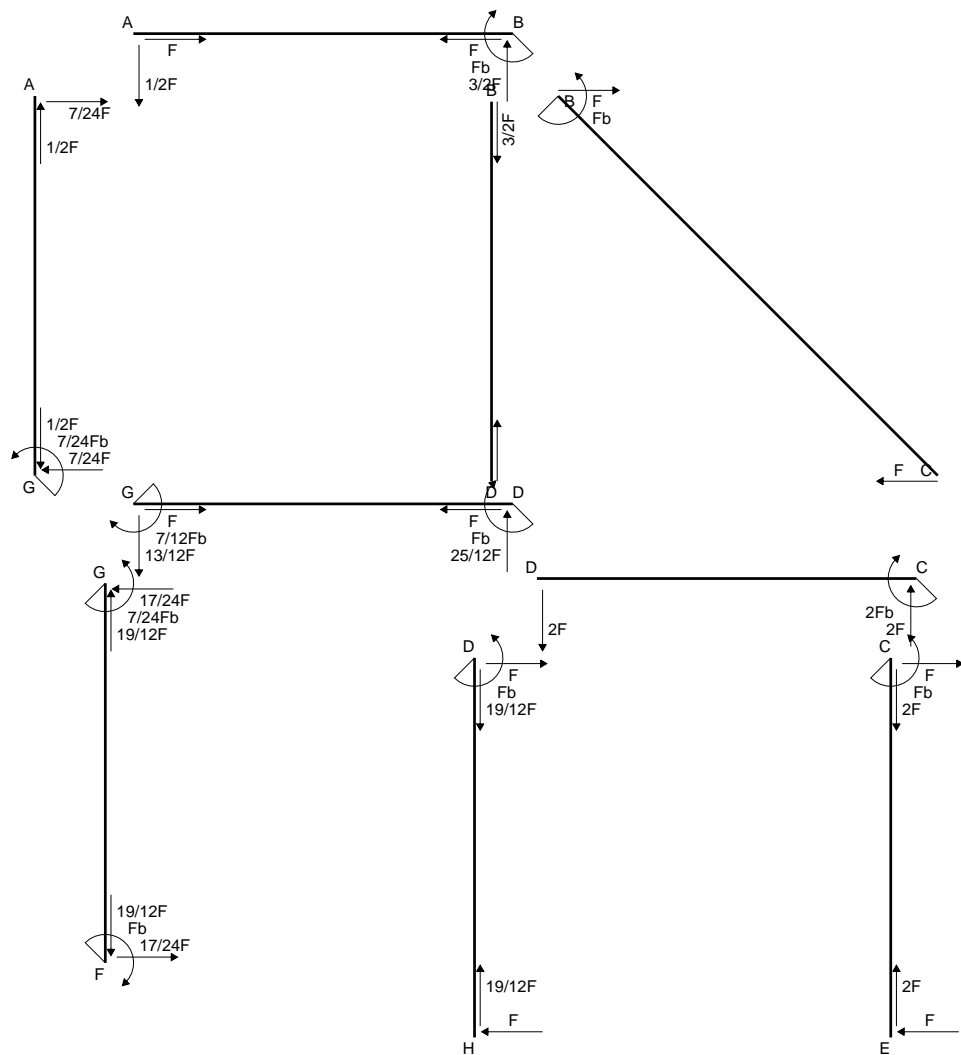

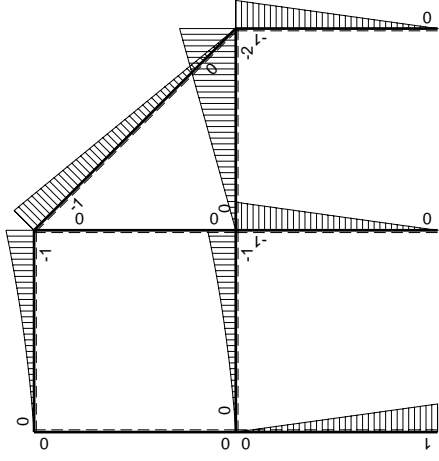
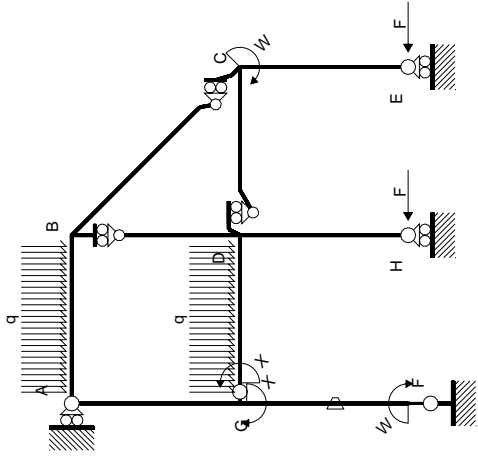

Schema di calcolo iperstatico

M_0 flessione da carichi assegnati



M_x flessione da iperstatica $X=1$

Quadro contributi PLV per iperstatica $X=W_{GD}$

→	$M_x(x)$	$M_o(x)$	θ	$M_x M_o$	$M_x \theta$	$M_x M_x$	$\int M_x(M_o/EJ+\theta)dx$	$\int X M_x M_x/EJdx$	
AB b	0	$-1/2Fx-1/2qx^2$	0	0	0	0	0+0	0	
BA b	0	$Fb-3/2Fx+1/2qx^2$	0	0	0	0	0	0	
BC $\sqrt{2}b$	0	$-Fb+\sqrt{2}/2Fx$	0	0	0	0	0	0	
BD b	0	0	0	0	0	0	0+0	0	
DB b	0	0	0	0	0	0	0	0	
DC b	0	$-2Fx$	0	0	0	0	0+0	0	
CD b	0	$2Fb-2Fx$	0	0	0	0	0	0	
CE b	0	$-Fb+Fx$	0	0	0	0	0+0	0	
EC b	0	Fx	0	0	0	0	0	0	
FG b	$-1/2x/b$	$Fb-Fx$	$-Fb/EJ$	$-1/2Fx+1/2Fx^2/b$	$1/2Fx/EJ$	$1/4x^2/b^2$	$(-1/12+1/4)Fb^2/EJ$	$1/12Xb/EJ$	
GF b	$1/2-1/2x/b$	$-Fx$	Fb/EJ	$-1/2Fx+1/2Fx^2/b$	$1/2Fb/EJ-1/2Fx/EJ$	$1/4-1/2x/b+1/4x^2/b^2$			
GD b	$-1+x/b$	$-1/2Fx-1/2qx^2$	0	$1/2Fx-1/2qx^3/b$	0	$1-2x/b+x^2/b^2$	$(1/8+0)Fb^2/EJ$	$1/3Xb/EJ$	
DG b	x/b	$Fb-3/2Fx+1/2qx^2$	0	$Fx-3/2Fx^2/b+1/2qx^3/b$	0	x^2/b^2			
DH b	0	$-Fb+Fx$	0	0	0	0	0+0	0	
HD b	0	Fx	0	0	0	0	0	0	
GA b	$1/2-1/2x/b$	0	0	0	0	$1/4-1/2x/b+1/4x^2/b^2$	0+0	$1/12Xb/EJ$	
AG b	$-1/2x/b$	0	0	0	0	$1/4x^2/b^2$			
	totali							$7/24Fb^2/EJ$	$1/2Xb/EJ$
	iperstatica $X=W_{GD}$							$-7/12Fb$	

Sviluppi di calcolo iperstatica

$$L_{FG}^{xx} = \int_0^b (1/4 x^2/b^2) 1/EJ dx = [1/12 x^3/b^2]_0^b 1/EJ$$

$$= (1/12 b) 1/EJ = 1/12 b/EJ$$

$$L_{GF}^{xx} = \int_0^b (1/4 - 1/2 x/b + 1/4 x^2/b^2) 1/EJ dx = [1/4 x - 1/4 x^2/b + 1/12 x^3/b^2]_0^b 1/EJ$$

$$= (1/4 b - 1/4 b + 1/12 b) 1/EJ = 1/12 b/EJ$$

$$L_{GD}^{xx} = \int_0^b (1 - 2 x/b + x^2/b^2) 1/EJ dx = [x - x^2/b + 1/3 x^3/b^2]_0^b 1/EJ$$

$$= (b - b + 1/3 b) 1/EJ = 1/3 b/EJ$$

$$L_{DG}^{xx} = \int_0^b (x^2/b^2) 1/EJ dx = [1/3 x^3/b^2]_0^b 1/EJ$$

$$= (1/3 b) 1/EJ = 1/3 b/EJ$$

$$L_{GA}^{xx} = \int_0^b (1/4 - 1/2 x/b + 1/4 x^2/b^2) 1/EJ dx = [1/4 x - 1/4 x^2/b + 1/12 x^3/b^2]_0^b 1/EJ$$

$$= (1/4 b - 1/4 b + 1/12 b) 1/EJ = 1/12 b/EJ$$

$$L_{AG}^{xx} = \int_0^b (1/4 x^2/b^2) 1/EJ dx = [1/12 x^3/b^2]_0^b 1/EJ$$

$$= (1/12 b) 1/EJ = 1/12 b/EJ$$

$$L_{FG}^{xo} = \int_0^b (-1/2 x/b + 1/2 x^2/b^2) Fb 1/EJ dx + \int_0^b (1/2 x/b) \theta dx$$

$$= [-1/4 x^2/b + 1/6 x^3/b^2]_0^b Fb 1/EJ + [1/4 x^2/b]_0^b \theta$$

$$= (-1/4 b + 1/6 b) Fb 1/EJ + (1/4 b) \theta = 1/6 Fb^2/EJ$$

$$L_{GF}^{xo} = \int_0^b (-1/2 x/b + 1/2 x^2/b^2) Fb 1/EJ dx + \int_0^b (-1/2 + 1/2 x/b) \theta dx$$

$$= [-1/4 x^2/b + 1/6 x^3/b^2]_0^b Fb 1/EJ + [-1/2 x + 1/4 x^2/b]_0^b \theta$$

$$= (-1/4 b + 1/6 b) Fb 1/EJ + (-1/2 b + 1/4 b) \theta = 1/6 Fb^2/EJ$$

$$L_{GD}^{xo} = \int_0^b (1/2 x/b - 1/2 x^3/b^3) Fb 1/EJ dx = [1/4 x^2/b - 1/8 x^4/b^3]_0^b Fb 1/EJ$$

$$= (1/4 b - 1/8 b) Fb 1/EJ = 1/8 Fb^2/EJ$$

$$L_{DG}^{xo} = \int_0^b (x/b - 3/2 x^2/b^2 + 1/2 x^3/b^3) Fb 1/EJ dx = [1/2 x^2/b - 1/2 x^3/b^2 + 1/8 x^4/b^3]_0^b Fb 1/EJ$$

$$= (1/2 b - 1/2 b + 1/8 b) Fb 1/EJ = 1/8 Fb^2/EJ$$

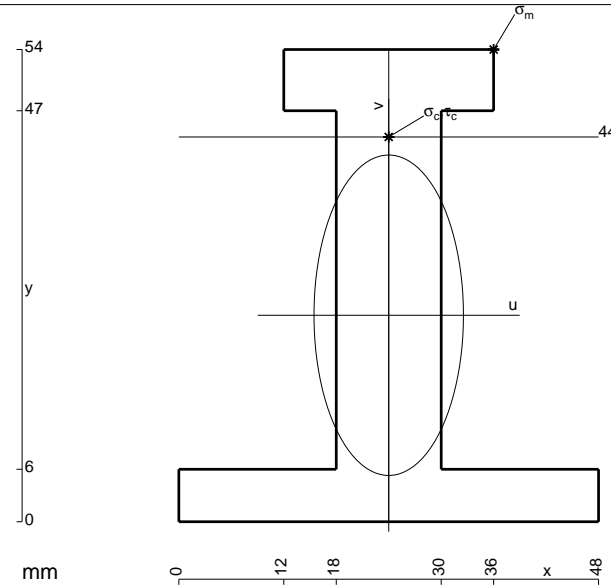

- A = 948. mm²
- J_u = 318391. mm⁴
- J_v = 69264. mm⁴
- y_g = 23.61 mm
- T_y = -2600. N
- M_x = -2496000. Nmm
- x_m = 36. mm
- y_m = 54. mm
- u_m = 12. mm
- v_m = 30.39 mm
- σ_m = -Mv/J_u = 238.2 N/mm²
- x_c = 24. mm
- y_c = 44. mm
- v_c = 20.39 mm
- σ_c = -Mv/J_u = 159.8 N/mm²
- τ_c = 3.61 N/mm²
- σ_q = √σ²+3τ² = 159.9 N/mm²
- S = 5305. mm³

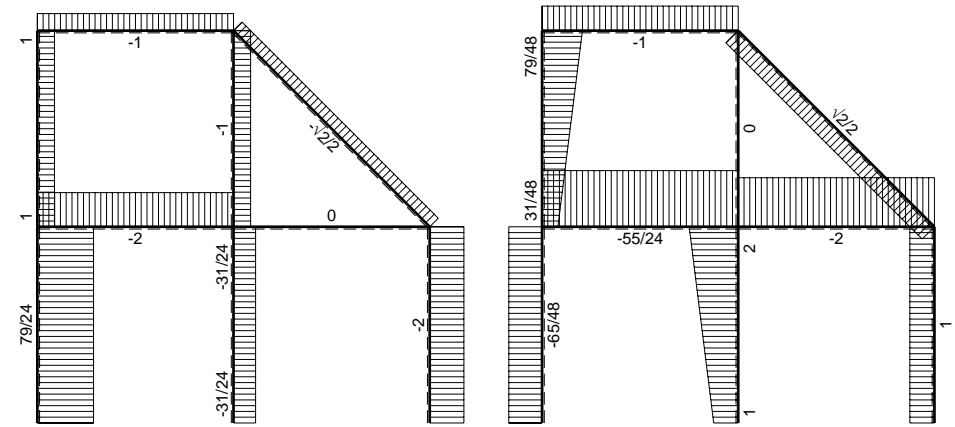
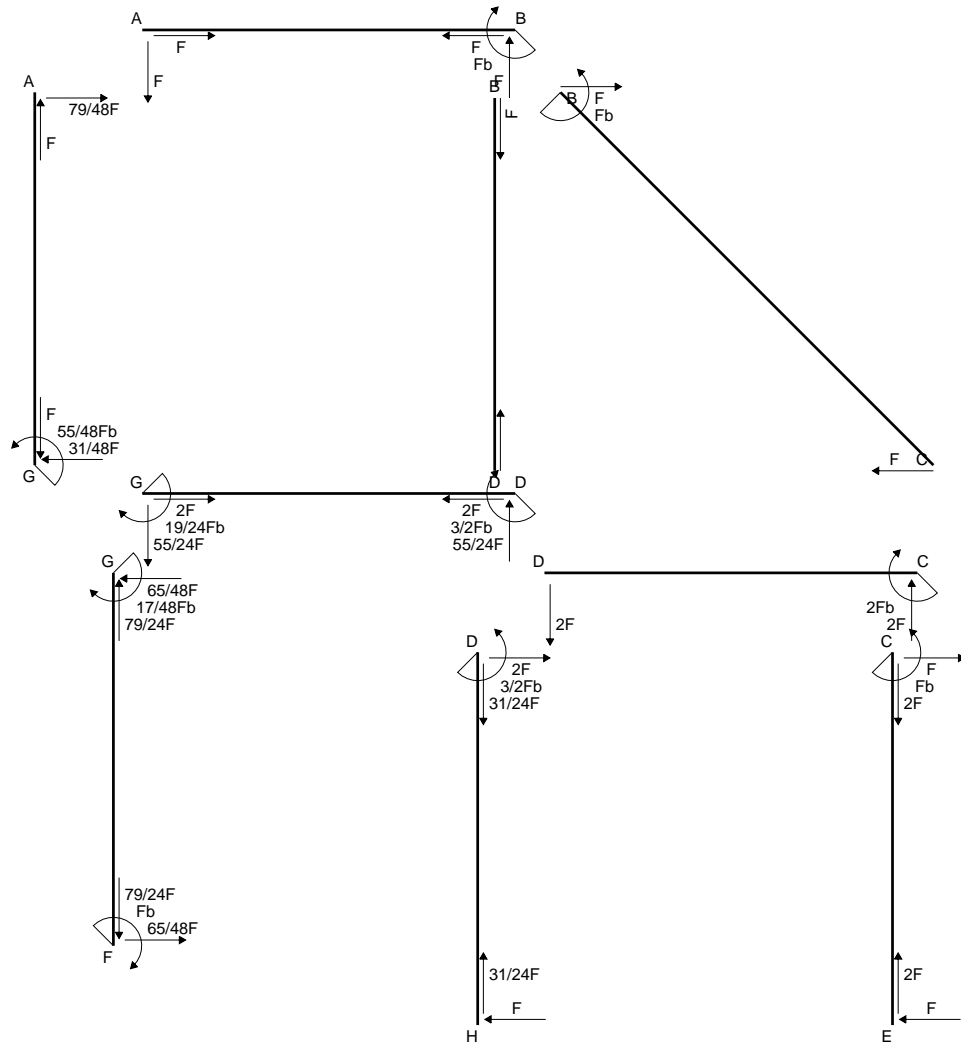

← ⊕ → F

↑ ⊕ ↓ F

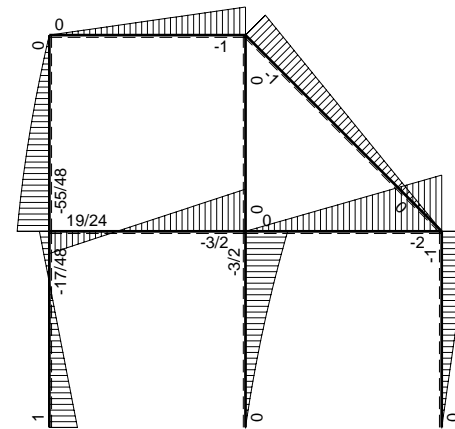

⊕ ⊖ Fb

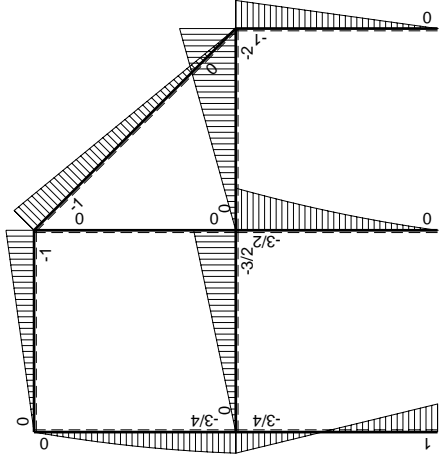
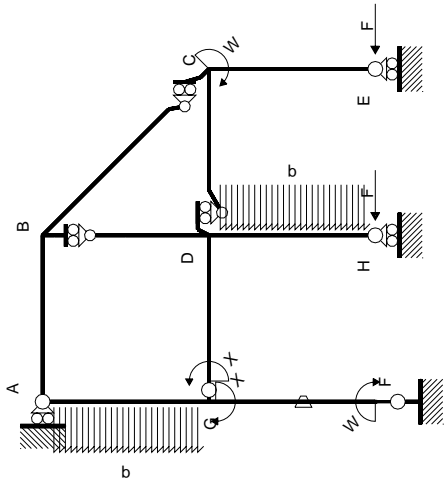

Schema di calcolo iperstatico

M_0 , flessione da carichi assegnati

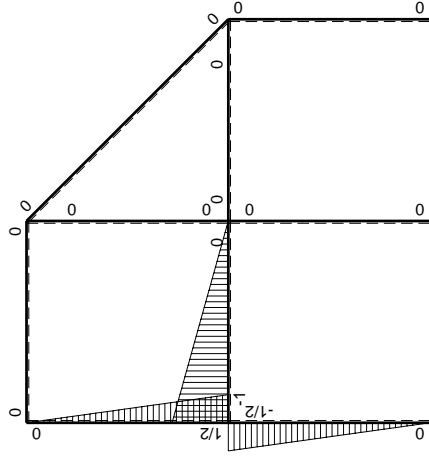

M_x , flessione da iperstatica $X=1$

Quadro contributi PLV per iperstatica $X=W_{GD}$

→	$M_x(x)$	$M_o(x)$	θ	$M_x M_o$	$M_x \theta$	$M_x M_x$	$\int M_x(M_o/EJ+\theta)dx$	$\int X M_x M_x/EJ dx$
AB b	0	-Fx	0	0	0	0	0+0	0
BA b	0	Fb-Fx	0	0	0	0	0	0
BC $\sqrt{2}b$	0	-Fb+ $\sqrt{2}/2Fx$	0	0	0	0	0	0
BD b	0	0	0	0	0	0	0+0	0
DB b	0	0	0	0	0	0	0	0
DC b	0	-2Fx	0	0	0	0	0+0	0
CD b	0	2Fb-2Fx	0	0	0	0	0	0
CE b	0	-Fb+Fx	0	0	0	0	0+0	0
EC b	0	Fx	0	0	0	0	0	0
FG b	-1/2x/b	Fb-7/4Fx	-Fb/EJ	-1/2Fx+7/8Fx ² /b	1/2Fx/EJ	1/4x ² /b ²	(1/24+1/4)Fb ² /EJ	1/12Xb/EJ
GF b	1/2-1/2x/b	3/4Fb-7/4Fx	Fb/EJ	3/8Fb-5/4Fx+7/8Fx ² /b	1/2Fb/EJ-1/2Fx/EJ	1/4-1/2x/b+1/4x ² /b ²		
GD b	-1+x/b	-3/2Fx	0	3/2Fx-3/2Fx ² /b	0	1-2x/b+x ² /b ²	(1/4+0)Fb ² /EJ	1/3Xb/EJ
DG b	x/b	3/2Fb-3/2Fx	0	3/2Fx-3/2Fx ² /b	0	x ² /b ²		
DH b	0	-3/2Fb+2Fx-1/2qx ²	0	0	0	0	0+0	0
HD b	0	Fx+1/2qx ²	0	0	0	0		
GA b	1/2-1/2x/b	-3/4Fb+1/4Fx+1/2qx ²	0	-3/8Fb+1/2Fx+1/8Fx ² /b-1/4qx ³ /b	0	1/4-1/2x/b+1/4x ² /b ²	(-7/48+0)Fb ² /EJ	1/12Xb/EJ
AG b	-1/2x/b	5/4Fx-1/2qx ²	0	-5/8Fx ² /b+1/4qx ³ /b	0	1/4x ² /b ²		
	totali						19/48Fb ² /EJ	1/2Xb/EJ
	iperstatica $X=W_{GD}$						-19/24Fb	

Sviluppi di calcolo iperstatica

$$L_{FG}^{xx} = \int_0^b (1/4 x^2/b^2) 1/EJ dx = [1/12 x^3/b^2]_0^b 1/EJ$$

$$= (1/12 b) 1/EJ = 1/12 b/EJ$$

$$L_{GF}^{xx} = \int_0^b (1/4 - 1/2 x/b + 1/4 x^2/b^2) 1/EJ dx = [1/4 x - 1/4 x^2/b + 1/12 x^3/b^2]_0^b 1/EJ$$

$$= (1/4 b - 1/4 b + 1/12 b) 1/EJ = 1/12 b/EJ$$

$$L_{GD}^{xx} = \int_0^b (1 - 2 x/b + x^2/b^2) 1/EJ dx = [x - x^2/b + 1/3 x^3/b^2]_0^b 1/EJ$$

$$= (b - b + 1/3 b) 1/EJ = 1/3 b/EJ$$

$$L_{DG}^{xx} = \int_0^b (x^2/b^2) 1/EJ dx = [1/3 x^3/b^2]_0^b 1/EJ$$

$$= (1/3 b) 1/EJ = 1/3 b/EJ$$

$$L_{GA}^{xx} = \int_0^b (1/4 - 1/2 x/b + 1/4 x^2/b^2) 1/EJ dx = [1/4 x - 1/4 x^2/b + 1/12 x^3/b^2]_0^b 1/EJ$$

$$= (1/4 b - 1/4 b + 1/12 b) 1/EJ = 1/12 b/EJ$$

$$L_{AG}^{xx} = \int_0^b (1/4 x^2/b^2) 1/EJ dx = [1/12 x^3/b^2]_0^b 1/EJ$$

$$= (1/12 b) 1/EJ = 1/12 b/EJ$$

$$L_{FG}^{x_0} = \int_0^b (-1/2 x/b + 7/8 x^2/b^2) Fb 1/EJ dx + \int_0^b (1/2 x/b) \theta dx$$

$$= [-1/4 x^2/b + 7/24 x^3/b^2]_0^b Fb 1/EJ + [1/4 x^2/b]_0^b \theta$$

$$= (-1/4 b + 7/24 b) Fb 1/EJ + (1/4 b) \theta = 7/24 Fb^2/EJ$$

$$L_{GF}^{x_0} = \int_0^b (3/8 - 5/4 x/b + 7/8 x^2/b^2) Fb 1/EJ dx + \int_0^b (-1/2 + 1/2 x/b) \theta dx$$

$$= [3/8 x - 5/8 x^2/b + 7/24 x^3/b^2]_0^b Fb 1/EJ + [-1/2 x + 1/4 x^2/b]_0^b \theta$$

$$= (3/8 b - 5/8 b + 7/24 b) Fb 1/EJ + (-1/2 b + 1/4 b) \theta = 7/24 Fb^2/EJ$$

$$L_{GD}^{x_0} = \int_0^b (3/2 x/b - 3/2 x^2/b^2) Fb 1/EJ dx = [3/4 x^2/b - 1/2 x^3/b^2]_0^b Fb 1/EJ$$

$$= (3/4 b - 1/2 b) Fb 1/EJ = 1/4 Fb^2/EJ$$

$$L_{DG}^{x_0} = \int_0^b (3/2 x/b - 3/2 x^2/b^2) Fb 1/EJ dx = [3/4 x^2/b - 1/2 x^3/b^2]_0^b Fb 1/EJ$$

$$= (3/4 b - 1/2 b) Fb 1/EJ = 1/4 Fb^2/EJ$$

$$L_{GA}^{x_0} = \int_0^b (-3/8 + 1/2 x/b + 1/8 x^2/b^2 - 1/4 x^3/b^3) Fb 1/EJ dx$$

$$= [-3/8 x + 1/4 x^2/b + 1/24 x^3/b^2 - 1/16 x^4/b^3]_0^b Fb 1/EJ$$

$$= (-3/8 b + 1/4 b + 1/24 b - 1/16 b) Fb 1/EJ = -7/48 Fb^2/EJ$$

$$L_{AG}^{x_0} = \int_0^b (-5/8 x^2/b^2 + 1/4 x^3/b^3) Fb 1/EJ dx = [-5/24 x^3/b^2 + 1/16 x^4/b^3]_0^b Fb 1/EJ$$

$$= (-5/24 b + 1/16 b) Fb 1/EJ = -7/48 Fb^2/EJ$$

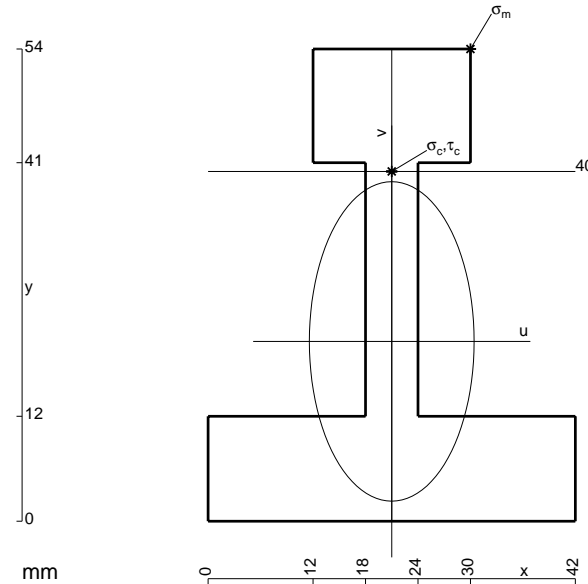

$$A = 912. \text{ mm}^2$$

$$J_u = 304351. \text{ mm}^4$$

$$J_v = 80928. \text{ mm}^4$$

$$y_g = 20.56 \text{ mm}$$

$$T_y = -3560. \text{ N}$$

$$M_x = -1815600. \text{ Nmm}$$

$$x_m = 30. \text{ mm}$$

$$y_m = 54. \text{ mm}$$

$$u_m = 9. \text{ mm}$$

$$v_m = 33.44 \text{ mm}$$

$$\sigma_m = -Mv/J_u = 199.5 \text{ N/mm}^2$$

$$x_c = 21. \text{ mm}$$

$$y_c = 40. \text{ mm}$$

$$v_c = 19.44 \text{ mm}$$

$$\sigma_c = -Mv/J_u = 116. \text{ N/mm}^2$$

$$\tau_c = 12.52 \text{ N/mm}^2$$

$$\sigma_o = \sqrt{\sigma^2 + 3\tau^2} = 118. \text{ N/mm}^2$$

$$S = 6424. \text{ mm}^3$$

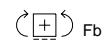
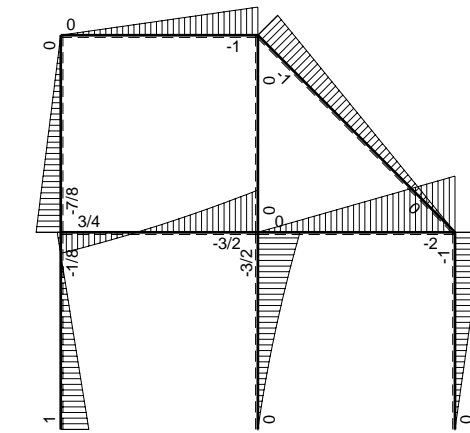
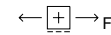
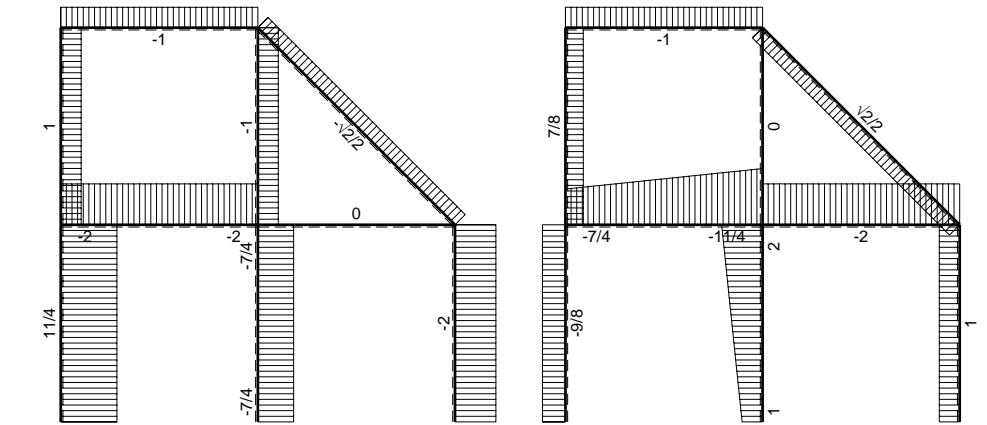
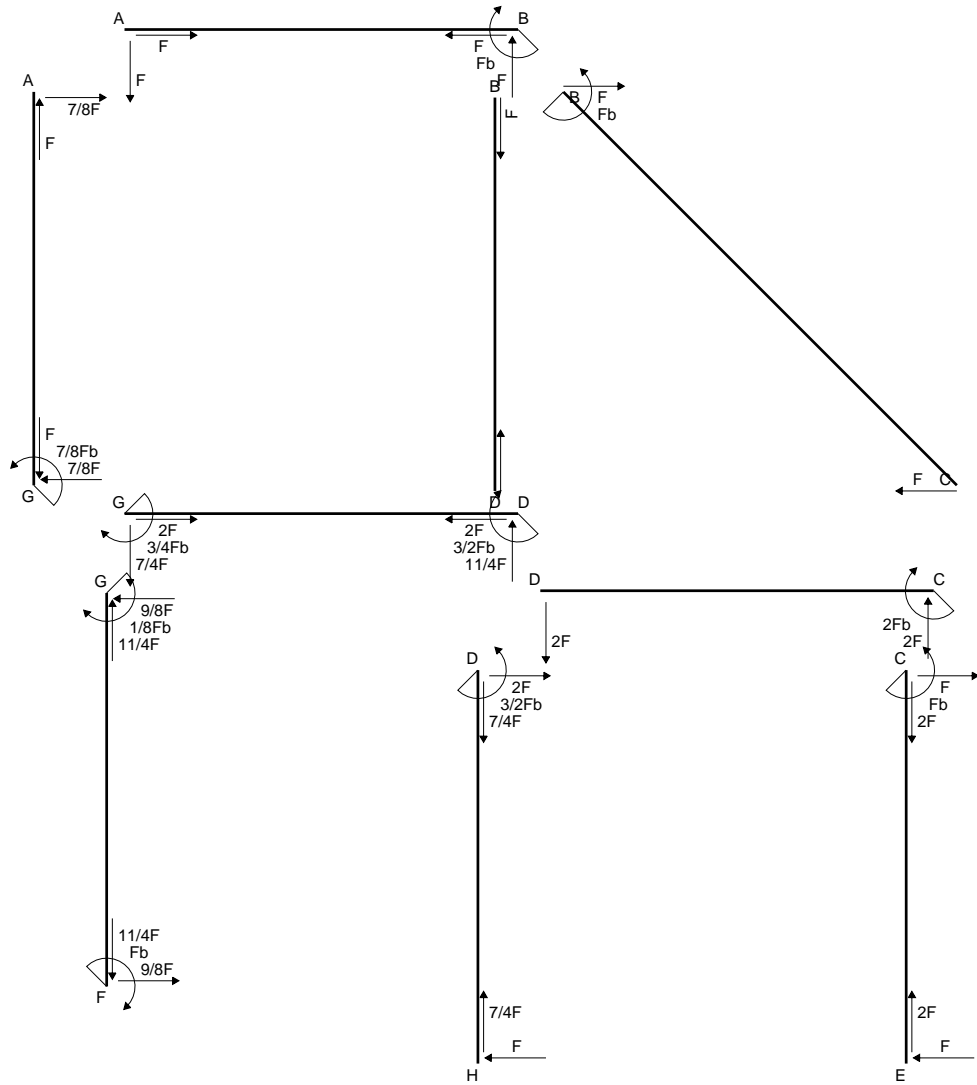

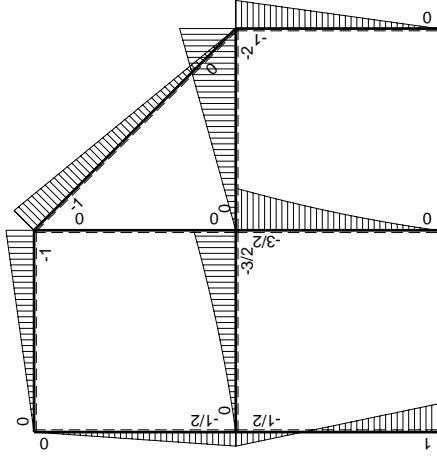
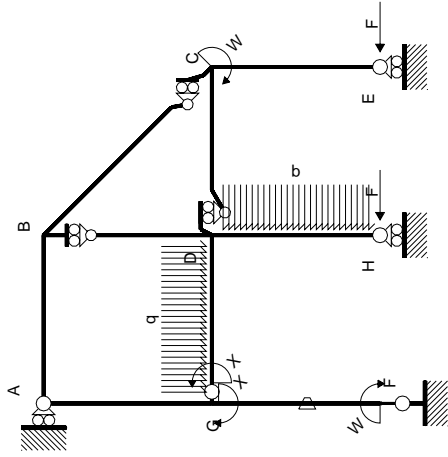

Schema di calcolo iperstatico

M_0 flessione da carichi assegnati

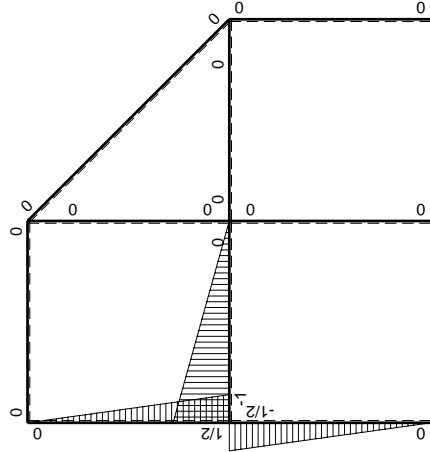

M_x flessione da iperstatica $X=1$

Quadro contributi PLV per iperstatica $X=W_{GD}$

→	$M_x(x)$	$M_o(x)$	θ	$M_x M_o$	$M_x \theta$	$M_x M_x$	$\int M_x(M_o/EJ+\theta)dx$	$\int X M_x M_x/EJdx$	
AB b	0	-Fx	0	0	0	0	0+0	0	
BA b	0	Fb-Fx	0	0	0	0	0	0	
BC $\sqrt{2}b$	0	-Fb+ $\sqrt{2}/2Fx$	0	0	0	0	0	0	
BD b	0	0	0	0	0	0	0+0	0	
DB b	0	0	0	0	0	0	0	0	
DC b	0	-2Fx	0	0	0	0	0+0	0	
CD b	0	2Fb-2Fx	0	0	0	0	0	0	
CE b	0	-Fb+Fx	0	0	0	0	0+0	0	
EC b	0	Fx	0	0	0	0	0	0	
FG b	-1/2x/b	Fb-3/2Fx	-Fb/EJ	-1/2Fx+3/4Fx ² /b	1/2Fx/EJ	1/4x ² /b ²	(0+1/4)Fb ² /EJ	1/12Xb/EJ	
GF b	1/2-1/2x/b	1/2Fb-3/2Fx	Fb/EJ	1/4Fb-Fx+3/4Fx ² /b	1/2Fb/EJ-1/2Fx/EJ	1/4-1/2x/b+1/4x ² /b ²			
GD b	-1+x/b	-Fx-1/2qx ²	0	Fx-1/2Fx ² /b-1/2qx ³ /b	0	1-2x/b+x ² /b ²	(5/24+0)Fb ² /EJ	1/3Xb/EJ	
DG b	x/b	3/2Fb-2Fx+1/2qx ²	0	3/2Fx-2Fx ² /b+1/2qx ³ /b	0	x ² /b ²			
DH b	0	-3/2Fb+2Fx-1/2qx ²	0	0	0	0	0+0	0	
HD b	0	Fx+1/2qx ²	0	0	0	0			
GA b	1/2-1/2x/b	-1/2Fb+1/2Fx	0	-1/4Fb+1/2Fx-1/4Fx ² /b	0	1/4-1/2x/b+1/4x ² /b ²	(-1/12+0)Fb ² /EJ	1/12Xb/EJ	
AG b	-1/2x/b	1/2Fx	0	-1/4Fx ² /b	0	1/4x ² /b ²			
	totali							3/8Fb ² /EJ	1/2Xb/EJ
	iperstatica $X=W_{GD}$							-3/4Fb	

Sviluppi di calcolo iperstatica

$$L_{FG}^{xx} = \int_0^b (1/4 x^2/b^2) 1/EJ dx = [1/12 x^3/b^2]_0^b 1/EJ$$

$$= (1/12 b) 1/EJ = 1/12 b/EJ$$

$$L_{GF}^{xx} = \int_0^b (1/4 - 1/2 x/b + 1/4 x^2/b^2) 1/EJ dx = [1/4 x - 1/4 x^2/b + 1/12 x^3/b^2]_0^b 1/EJ$$

$$= (1/4 b - 1/4 b + 1/12 b) 1/EJ = 1/12 b/EJ$$

$$L_{GD}^{xx} = \int_0^b (1 - 2 x/b + x^2/b^2) 1/EJ dx = [x - x^2/b + 1/3 x^3/b^2]_0^b 1/EJ$$

$$= (b - b + 1/3 b) 1/EJ = 1/3 b/EJ$$

$$L_{DG}^{xx} = \int_0^b (x^2/b^2) 1/EJ dx = [1/3 x^3/b^2]_0^b 1/EJ$$

$$= (1/3 b) 1/EJ = 1/3 b/EJ$$

$$L_{GA}^{xx} = \int_0^b (1/4 - 1/2 x/b + 1/4 x^2/b^2) 1/EJ dx = [1/4 x - 1/4 x^2/b + 1/12 x^3/b^2]_0^b 1/EJ$$

$$= (1/4 b - 1/4 b + 1/12 b) 1/EJ = 1/12 b/EJ$$

$$L_{AG}^{xx} = \int_0^b (1/4 x^2/b^2) 1/EJ dx = [1/12 x^3/b^2]_0^b 1/EJ$$

$$= (1/12 b) 1/EJ = 1/12 b/EJ$$

$$L_{FG}^{xo} = \int_0^b (-1/2 x/b + 3/4 x^2/b^2) Fb 1/EJ dx + \int_0^b (1/2 x/b) \theta dx$$

$$= [-1/4 x^2/b + 1/4 x^3/b^2]_0^b Fb 1/EJ + [1/4 x^2/b]_0^b \theta$$

$$= (-1/4 b + 1/4 b) Fb 1/EJ + (1/4 b) \theta = 1/4 Fb^2/EJ$$

$$L_{GF}^{xo} = \int_0^b (1/4 - x/b + 3/4 x^2/b^2) Fb 1/EJ dx + \int_0^b (-1/2 + 1/2 x/b) \theta dx$$

$$= [1/4 x - 1/2 x^2/b + 1/4 x^3/b^2]_0^b Fb 1/EJ + [-1/2 x + 1/4 x^2/b]_0^b \theta$$

$$= (1/4 b - 1/2 b + 1/4 b) Fb 1/EJ + (-1/2 b + 1/4 b) \theta = 1/4 Fb^2/EJ$$

$$L_{GD}^{xo} = \int_0^b (x/b - 1/2 x^2/b^2 - 1/2 x^3/b^3) Fb 1/EJ dx = [1/2 x^2/b - 1/6 x^3/b^2 - 1/8 x^4/b^3]_0^b Fb 1/EJ$$

$$= (1/2 b - 1/6 b - 1/8 b) Fb 1/EJ = 5/24 Fb^2/EJ$$

$$L_{DG}^{xo} = \int_0^b (3/2 x/b - 2 x^2/b^2 + 1/2 x^3/b^3) Fb 1/EJ dx = [3/4 x^2/b - 2/3 x^3/b^2 + 1/8 x^4/b^3]_0^b Fb 1/EJ$$

$$= (3/4 b - 2/3 b + 1/8 b) Fb 1/EJ = 5/24 Fb^2/EJ$$

$$L_{GA}^{xo} = \int_0^b (-1/4 + 1/2 x/b - 1/4 x^2/b^2) Fb 1/EJ dx = [-1/4 x + 1/4 x^2/b - 1/12 x^3/b^2]_0^b Fb 1/EJ$$

$$= (-1/4 b + 1/4 b - 1/12 b) Fb 1/EJ = -1/12 Fb^2/EJ$$

$$L_{AG}^{xo} = \int_0^b (-1/4 x^2/b^2) Fb 1/EJ dx = [-1/12 x^3/b^2]_0^b Fb 1/EJ$$

$$= (-1/12 b) Fb 1/EJ = -1/12 Fb^2/EJ$$

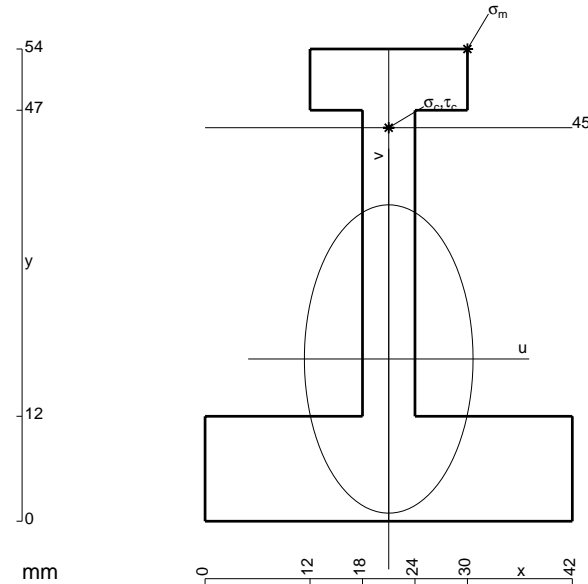

- A = 840. mm²
- J_u = 261182. mm⁴
- J_v = 78120. mm⁴
- y_g = 18.55 mm
- T_y = -2760. N
- M_x = -1545600. Nmm
- x_m = 30. mm
- y_m = 54. mm
- u_m = 9. mm
- v_m = 35.45 mm
- σ_m = -Mv/J_u = 209.8 N/mm²
- x_c = 21. mm
- y_c = 45. mm
- v_c = 26.45 mm
- σ_c = -Mv/J_u = 156.5 N/mm²
- τ_c = 7.67 N/mm²
- σ_o = √σ²+3τ² = 157.1 N/mm²
- S = 4355. mm³

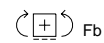
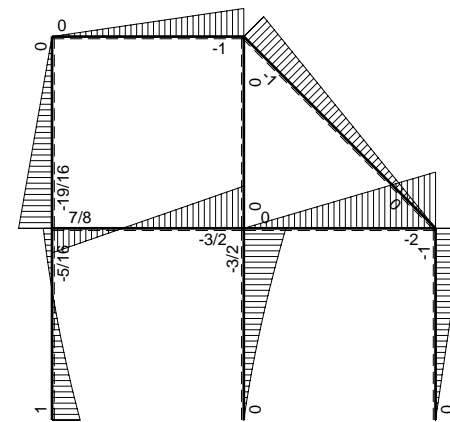
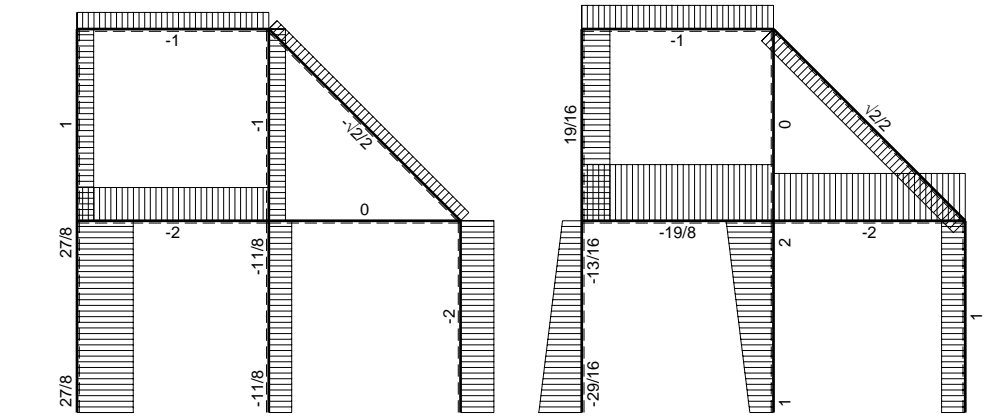
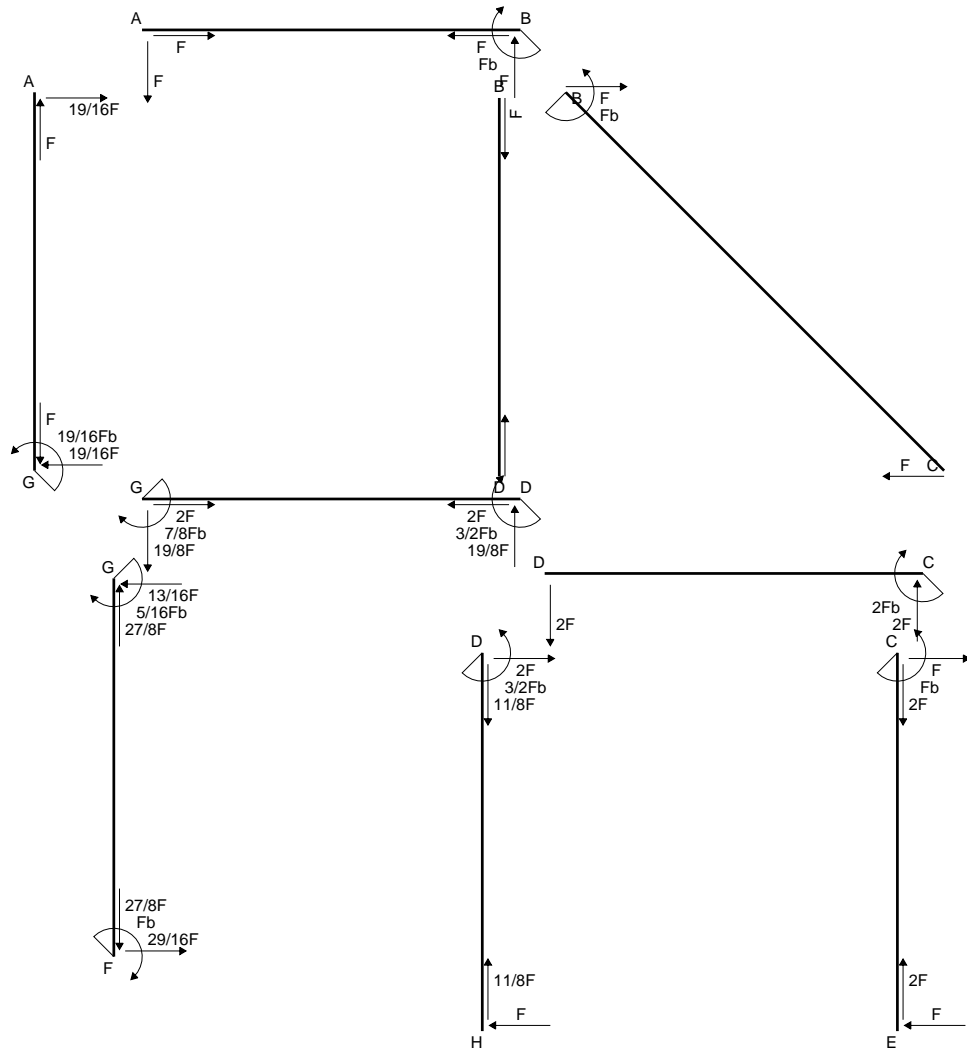

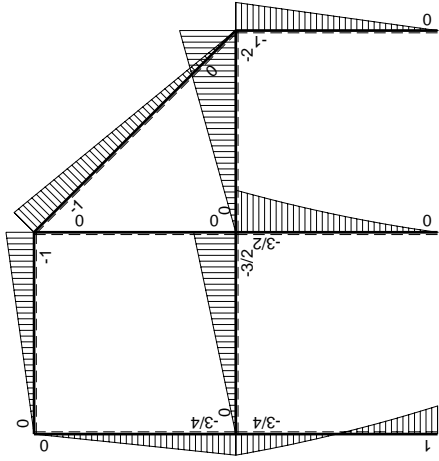
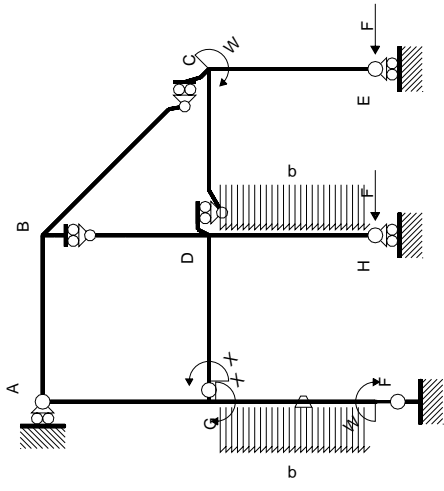

Schema di calcolo iperstatico

M_0 flessione da carichi assegnati

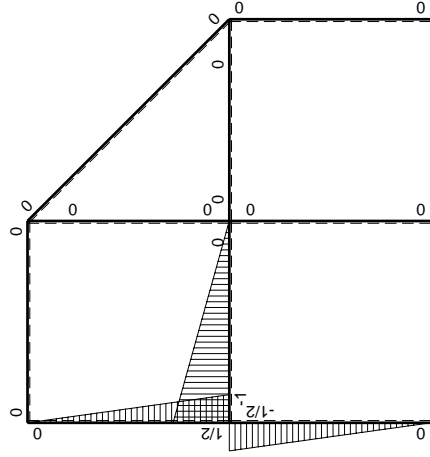

M_x flessione da iperstatica $X=1$

Quadro contributi PLV per iperstatica $X=W_{GD}$

→	$M_x(x)$	$M_o(x)$	θ	$M_x M_o$	$M_x \theta$	$M_x M_x$	$\int M_x(M_o/EJ+\theta)dx$	$\int X M_x M_x / EJ dx$
AB b	0	-Fx	0	0	0	0	0+0	0
BA b	0	Fb-Fx	0	0	0	0	0	0
BC $\sqrt{2}b$	0	-Fb+ $\sqrt{2}/2Fx$	0	0	0	0	0	0
BD b	0	0	0	0	0	0	0+0	0
DB b	0	0	0	0	0	0	0	0
DC b	0	-2Fx	0	0	0	0	0+0	0
CD b	0	2Fb-2Fx	0	0	0	0	0	0
CE b	0	-Fb+Fx	0	0	0	0	0+0	0
EC b	0	Fx	0	0	0	0	0	0
FG b	-1/2x/b	Fb-9/4Fx+1/2qx ²	-Fb/EJ	-1/2Fx+9/8Fx ² /b-1/4qx ³ /b	1/2Fx/EJ	1/4x ² /b ²	(1/16+1/4)Fb ² /EJ	1/12Xb/EJ
GF b	1/2-1/2x/b	3/4Fb-5/4Fx-1/2qx ²	Fb/EJ	3/8Fb-Fx+3/8Fx ² /b+1/4qx ³ /b	1/2Fb/EJ-1/2Fx/EJ	1/4-1/2x/b+1/4x ² /b ²		
GD b	-1+x/b	-3/2Fx	0	3/2Fx-3/2Fx ² /b	0	1-2x/b+x ² /b ²	(1/4+0)Fb ² /EJ	1/3Xb/EJ
DG b	x/b	3/2Fb-3/2Fx	0	3/2Fx-3/2Fx ² /b	0	x ² /b ²		
DH b	0	-3/2Fb+2Fx-1/2qx ²	0	0	0	0	0+0	0
HD b	0	Fx+1/2qx ²	0	0	0	0	0	0
GA b	1/2-1/2x/b	-3/4Fb+3/4Fx	0	-3/8Fb+3/4Fx-3/8Fx ² /b	0	1/4-1/2x/b+1/4x ² /b ²	(-1/8+0)Fb ² /EJ	1/12Xb/EJ
AG b	-1/2x/b	3/4Fx	0	-3/8Fx ² /b	0	1/4x ² /b ²		
	totali						7/16Fb ² /EJ	1/2Xb/EJ
	iperstatica $X=W_{GD}$						-7/8Fb	

Sviluppi di calcolo iperstatica

$$L_{FG}^{xx} = \int_0^b (1/4 x^2/b^2) 1/EJ dx = [1/12 x^3/b^2]_0^b 1/EJ$$

$$= (1/12 b) 1/EJ = 1/12 b/EJ$$

$$L_{GF}^{xx} = \int_0^b (1/4 -1/2 x/b +1/4 x^2/b^2) 1/EJ dx = [1/4 x -1/4 x^2/b +1/12 x^3/b^2]_0^b 1/EJ$$

$$= (1/4 b -1/4 b +1/12 b) 1/EJ = 1/12 b/EJ$$

$$L_{GD}^{xx} = \int_0^b (1 -2 x/b + x^2/b^2) 1/EJ dx = [x - x^2/b +1/3 x^3/b^2]_0^b 1/EJ$$

$$= (b - b +1/3 b) 1/EJ = 1/3 b/EJ$$

$$L_{DG}^{xx} = \int_0^b (x^2/b^2) 1/EJ dx = [1/3 x^3/b^2]_0^b 1/EJ$$

$$= (1/3 b) 1/EJ = 1/3 b/EJ$$

$$L_{GA}^{xx} = \int_0^b (1/4 -1/2 x/b +1/4 x^2/b^2) 1/EJ dx = [1/4 x -1/4 x^2/b +1/12 x^3/b^2]_0^b 1/EJ$$

$$= (1/4 b -1/4 b +1/12 b) 1/EJ = 1/12 b/EJ$$

$$L_{AG}^{xx} = \int_0^b (1/4 x^2/b^2) 1/EJ dx = [1/12 x^3/b^2]_0^b 1/EJ$$

$$= (1/12 b) 1/EJ = 1/12 b/EJ$$

$$L_{FG}^{xo} = \int_0^b (-1/2 x/b +9/8 x^2/b^2 -1/4 x^3/b^3) Fb 1/EJ dx + \int_0^b (1/2 x/b) \theta dx$$

$$= [-1/4 x^2/b +3/8 x^3/b^2 -1/16 x^4/b^3]_0^b Fb 1/EJ + [1/4 x^2/b]_0^b \theta$$

$$= (-1/4 b +3/8 b -1/16 b) Fb 1/EJ + (1/4 b) \theta = 5/16 Fb^2/EJ$$

$$L_{GF}^{xo} = \int_0^b (3/8 - x/b +3/8 x^2/b^2 +1/4 x^3/b^3) Fb 1/EJ dx + \int_0^b (-1/2 +1/2 x/b) \theta dx$$

$$= [3/8 x -1/2 x^2/b +1/8 x^3/b^2 +1/16 x^4/b^3]_0^b Fb 1/EJ + [-1/2 x +1/4 x^2/b]_0^b \theta$$

$$= (3/8 b -1/2 b +1/8 b +1/16 b) Fb 1/EJ + (-1/2 b +1/4 b) \theta = 5/16 Fb^2/EJ$$

$$L_{GD}^{xo} = \int_0^b (3/2 x/b -3/2 x^2/b^2) Fb 1/EJ dx = [3/4 x^2/b -1/2 x^3/b^2]_0^b Fb 1/EJ$$

$$= (3/4 b -1/2 b) Fb 1/EJ = 1/4 Fb^2/EJ$$

$$L_{DG}^{xo} = \int_0^b (3/2 x/b -3/2 x^2/b^2) Fb 1/EJ dx = [3/4 x^2/b -1/2 x^3/b^2]_0^b Fb 1/EJ$$

$$= (3/4 b -1/2 b) Fb 1/EJ = 1/4 Fb^2/EJ$$

$$L_{GA}^{xo} = \int_0^b (-3/8 +3/4 x/b -3/8 x^2/b^2) Fb 1/EJ dx = [-3/8 x +3/8 x^2/b -1/8 x^3/b^2]_0^b Fb 1/EJ$$

$$= (-3/8 b +3/8 b -1/8 b) Fb 1/EJ = -1/8 Fb^2/EJ$$

$$L_{AG}^{xo} = \int_0^b (-3/8 x^2/b^2) Fb 1/EJ dx = [-1/8 x^3/b^2]_0^b Fb 1/EJ$$

$$= (-1/8 b) Fb 1/EJ = -1/8 Fb^2/EJ$$

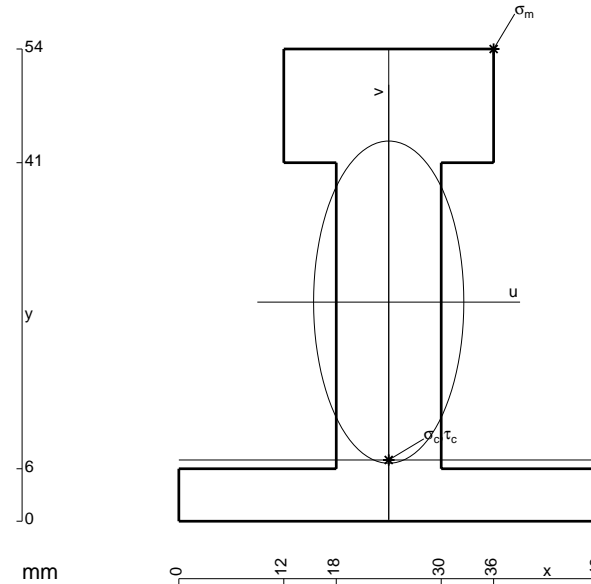

- A = 1020. mm²
- J_u = 346417. mm⁴
- J_v = 75312. mm⁴
- y_g = 25.05 mm
- T_y = -4300. N
- M_x = -2623000. Nmm
- x_m = 36. mm
- y_m = 54. mm
- u_m = 12. mm
- v_m = 28.95 mm
- σ_m = -Mv/J_u = 219.2 N/mm²
- x_c = 24. mm
- y_c = 7. mm
- v_c = -18.05 mm
- σ_c = -Mv/J_u = -136.7 N/mm²
- τ_c = 6.8 N/mm²
- σ_o = √σ²+3τ² = 137.2 N/mm²
- S = 6574. mm³

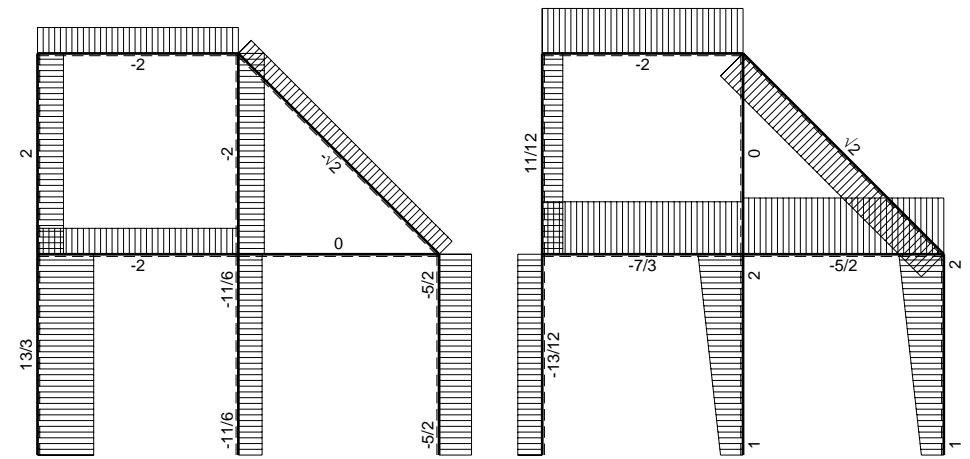
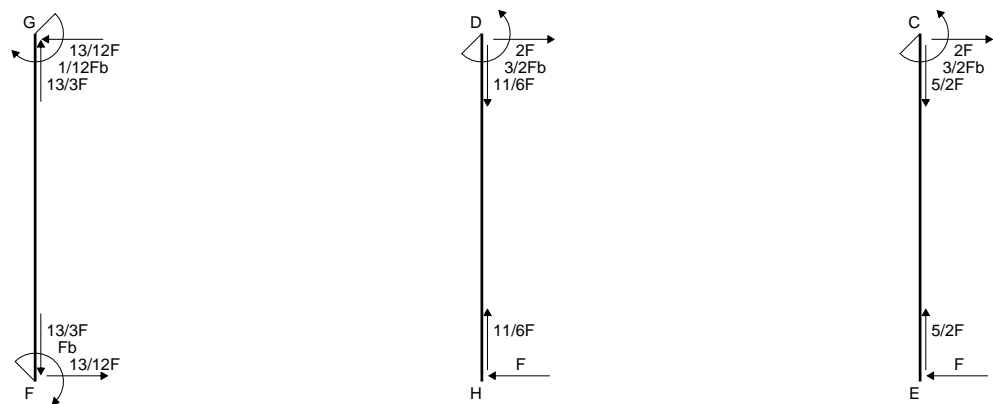
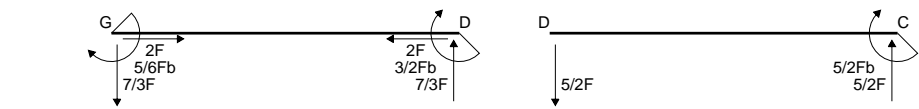
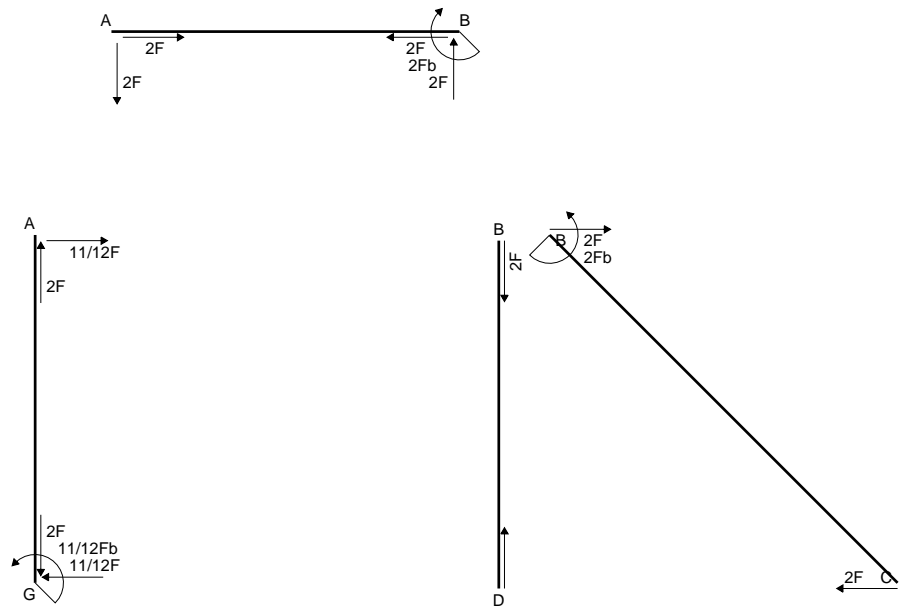

← ⊕ → F

↑ ⊕ ↓ Fb

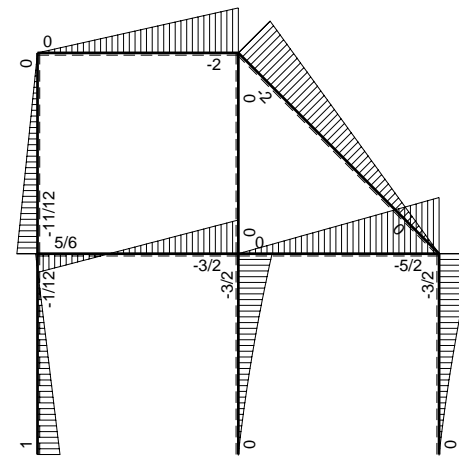

⊕ ⊖ Fb

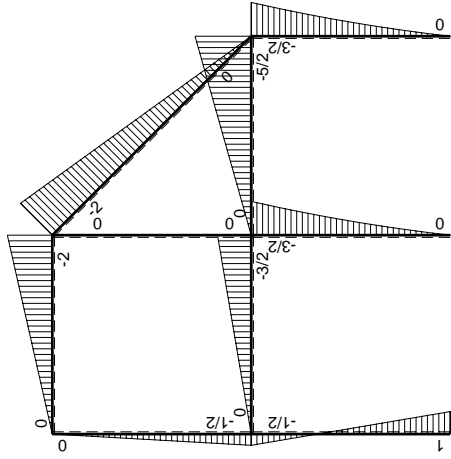
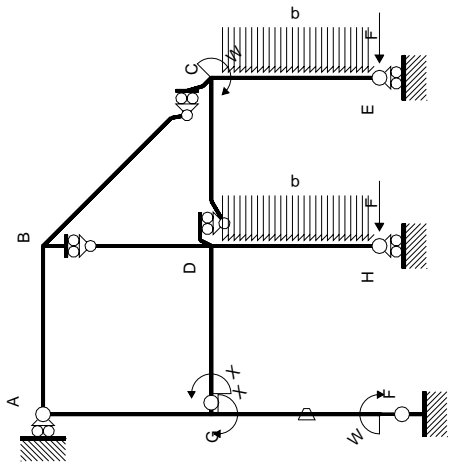

Schema di calcolo iperstatico

M_0 flessione da carichi assegnati

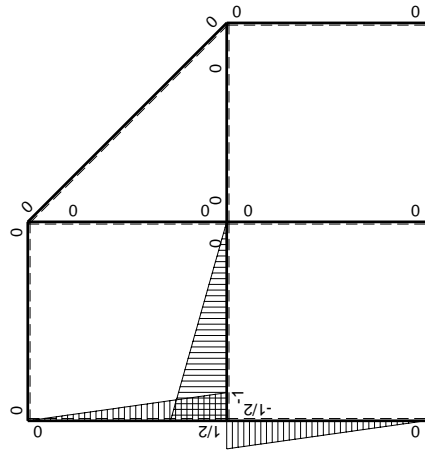

M_1 flessione da iperstatica $X=1$

Quadro contributi PLV per iperstatica $X=W_{GD}$

→	$M_x(x)$	$M_o(x)$	θ	$M_x M_o$	$M_x \theta$	$M_x M_x$	$\int M_x(M_o/EJ+\theta)dx$	$\int X M_x M_x/EJ dx$
AB b	0	-2Fx	0	0	0	0	0+0	0
BA b	0	2Fb-2Fx	0	0	0	0	0	0
BC $\sqrt{2}b$	0	-2Fb+ $\sqrt{2}Fx$	0	0	0	0	0	0
BD b	0	0	0	0	0	0	0+0	0
DB b	0	0	0	0	0	0	0	0
DC b	0	-5/2Fx	0	0	0	0	0+0	0
CD b	0	5/2Fb-5/2Fx	0	0	0	0	0	0
CE b	0	-3/2Fb+2Fx-1/2qx ²	0	0	0	0	0+0	0
EC b	0	Fx+1/2qx ²	0	0	0	0	0	0
FG b	-1/2x/b	Fb-3/2Fx	-Fb/EJ	-1/2Fx+3/4Fx ² /b	1/2Fx/EJ	1/4x ² /b ²	(0+1/4)Fb ² /EJ	1/12Xb/EJ
GF b	1/2-1/2x/b	1/2Fb-3/2Fx	Fb/EJ	1/4Fb-Fx+3/4Fx ² /b	1/2Fb/EJ-1/2Fx/EJ	1/4-1/2x/b+1/4x ² /b ²		
GD b	-1+x/b	-3/2Fx	0	3/2Fx-3/2Fx ² /b	0	1-2x/b+x ² /b ²	(1/4+0)Fb ² /EJ	1/3Xb/EJ
DG b	x/b	3/2Fb-3/2Fx	0	3/2Fx-3/2Fx ² /b	0	x ² /b ²		
DH b	0	-3/2Fb+2Fx-1/2qx ²	0	0	0	0	0+0	0
HD b	0	Fx+1/2qx ²	0	0	0	0	0	0
GA b	1/2-1/2x/b	-1/2Fb+1/2Fx	0	-1/4Fb+1/2Fx-1/4Fx ² /b	0	1/4-1/2x/b+1/4x ² /b ²	(-1/12+0)Fb ² /EJ	1/12Xb/EJ
AG b	-1/2x/b	1/2Fx	0	-1/4Fx ² /b	0	1/4x ² /b ²		
	totali						5/12Fb ² /EJ	1/2Xb/EJ
	iperstatica $X=W_{GD}$						-5/6Fb	

Sviluppi di calcolo iperstatica

$$L_{FG}^{xx} = \int_0^b (1/4 x^2/b^2) 1/EJ dx = [1/12 x^3/b^2]_0^b 1/EJ$$

$$= (1/12 b) 1/EJ = 1/12 b/EJ$$

$$L_{GF}^{xx} = \int_0^b (1/4 - 1/2 x/b + 1/4 x^2/b^2) 1/EJ dx = [1/4 x - 1/4 x^2/b + 1/12 x^3/b^2]_0^b 1/EJ$$

$$= (1/4 b - 1/4 b + 1/12 b) 1/EJ = 1/12 b/EJ$$

$$L_{GD}^{xx} = \int_0^b (1 - 2 x/b + x^2/b^2) 1/EJ dx = [x - x^2/b + 1/3 x^3/b^2]_0^b 1/EJ$$

$$= (b - b + 1/3 b) 1/EJ = 1/3 b/EJ$$

$$L_{DG}^{xx} = \int_0^b (x^2/b^2) 1/EJ dx = [1/3 x^3/b^2]_0^b 1/EJ$$

$$= (1/3 b) 1/EJ = 1/3 b/EJ$$

$$L_{GA}^{xx} = \int_0^b (1/4 - 1/2 x/b + 1/4 x^2/b^2) 1/EJ dx = [1/4 x - 1/4 x^2/b + 1/12 x^3/b^2]_0^b 1/EJ$$

$$= (1/4 b - 1/4 b + 1/12 b) 1/EJ = 1/12 b/EJ$$

$$L_{AG}^{xx} = \int_0^b (1/4 x^2/b^2) 1/EJ dx = [1/12 x^3/b^2]_0^b 1/EJ$$

$$= (1/12 b) 1/EJ = 1/12 b/EJ$$

$$L_{FG}^{xo} = \int_0^b (-1/2 x/b + 3/4 x^2/b^2) Fb 1/EJ dx + \int_0^b (1/2 x/b) \theta dx$$

$$= [-1/4 x^2/b + 1/4 x^3/b^2]_0^b Fb 1/EJ + [1/4 x^2/b]_0^b \theta$$

$$= (-1/4 b + 1/4 b) Fb 1/EJ + (1/4 b) \theta = 1/4 Fb^2/EJ$$

$$L_{GF}^{xo} = \int_0^b (1/4 - x/b + 3/4 x^2/b^2) Fb 1/EJ dx + \int_0^b (-1/2 + 1/2 x/b) \theta dx$$

$$= [1/4 x - 1/2 x^2/b + 1/4 x^3/b^2]_0^b Fb 1/EJ + [-1/2 x + 1/4 x^2/b]_0^b \theta$$

$$= (1/4 b - 1/2 b + 1/4 b) Fb 1/EJ + (-1/2 b + 1/4 b) \theta = 1/4 Fb^2/EJ$$

$$L_{GD}^{xo} = \int_0^b (3/2 x/b - 3/2 x^2/b^2) Fb 1/EJ dx = [3/4 x^2/b - 1/2 x^3/b^2]_0^b Fb 1/EJ$$

$$= (3/4 b - 1/2 b) Fb 1/EJ = 1/4 Fb^2/EJ$$

$$L_{DG}^{xo} = \int_0^b (3/2 x/b - 3/2 x^2/b^2) Fb 1/EJ dx = [3/4 x^2/b - 1/2 x^3/b^2]_0^b Fb 1/EJ$$

$$= (3/4 b - 1/2 b) Fb 1/EJ = 1/4 Fb^2/EJ$$

$$L_{GA}^{xo} = \int_0^b (-1/4 + 1/2 x/b - 1/4 x^2/b^2) Fb 1/EJ dx = [-1/4 x + 1/4 x^2/b - 1/12 x^3/b^2]_0^b Fb 1/EJ$$

$$= (-1/4 b + 1/4 b - 1/12 b) Fb 1/EJ = -1/12 Fb^2/EJ$$

$$L_{AG}^{xo} = \int_0^b (-1/4 x^2/b^2) Fb 1/EJ dx = [-1/12 x^3/b^2]_0^b Fb 1/EJ$$

$$= (-1/12 b) Fb 1/EJ = -1/12 Fb^2/EJ$$

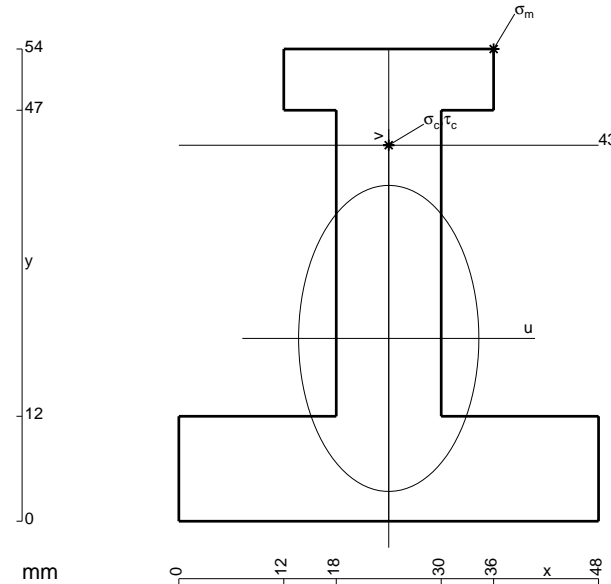

- A = 1164. mm²
- J_u = 356609. mm⁴
- J_v = 123696. mm⁴
- y_g = 20.9 mm
- T_y = -3750. N
- M_x = -2475000. Nmm
- x_m = 36. mm
- y_m = 54. mm
- u_m = 12. mm
- v_m = 33.1 mm
- σ_m = -Mv/J_u = 229.7 N/mm²
- x_c = 24. mm
- y_c = 43. mm
- v_c = 22.1 mm
- σ_c = -Mv/J_u = 153.4 N/mm²
- τ_c = 5.371 N/mm²
- σ_o = √σ²+3τ² = 153.6 N/mm²
- S = 6129. mm³

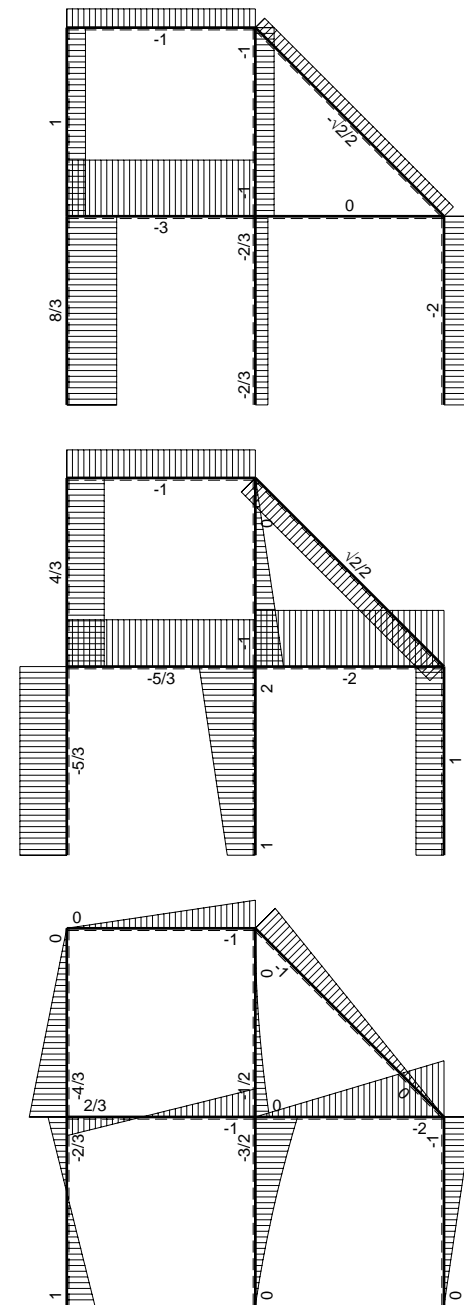
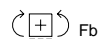
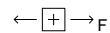
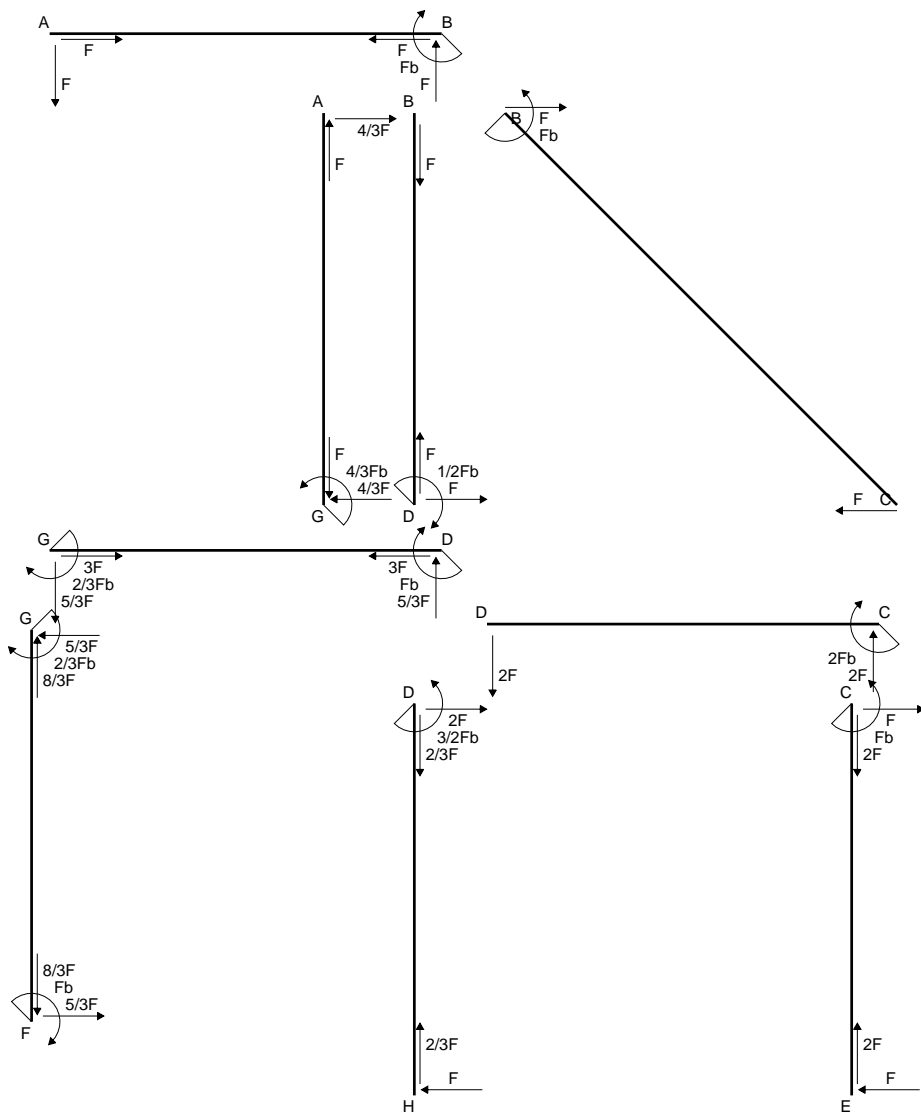

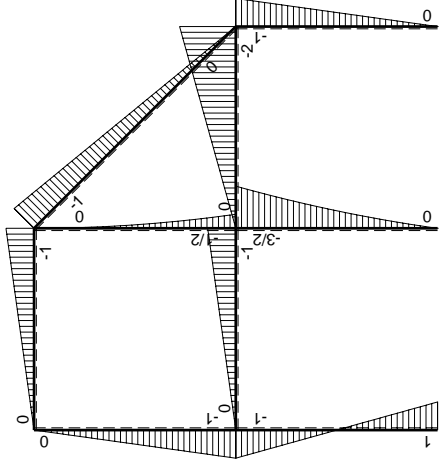
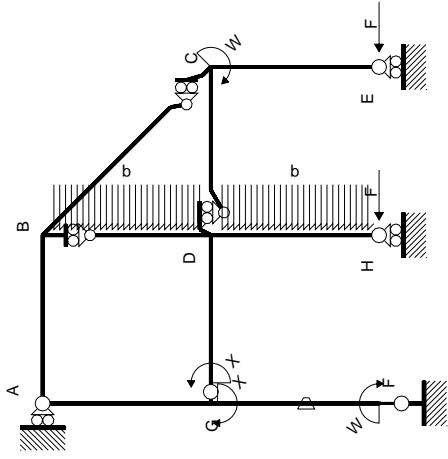

Schema di calcolo iperstatico

M_0 flessione da carichi assegnati



M_x flessione da iperstatica $X=1$

Quadro contributi PLV per iperstatica $X=W_{GD}$

→	$M_x(x)$	$M_o(x)$	θ	$M_x M_o$	$M_x \theta$	$M_x M_x$	$\int M_x(M_o/EJ+\theta)dx$	$\int X M_x M_x/EJ dx$	
AB b	0	-Fx	0	0	0	0	0+0	0	
BA b	0	Fb-Fx	0	0	0	0	0	0	
BC $\sqrt{2}b$	0	-Fb+ $\sqrt{2}/2Fx$	0	0	0	0	0	0	
BD b	0	-1/2qx ²	0	0	0	0	0+0	0	
DB b	0	1/2Fb-Fx+1/2qx ²	0	0	0	0	0	0	
DC b	0	-2Fx	0	0	0	0	0+0	0	
CD b	0	2Fb-2Fx	0	0	0	0	0	0	
CE b	0	-Fb+Fx	0	0	0	0	0+0	0	
EC b	0	Fx	0	0	0	0	0	0	
FG b	-1/2x/b	Fb-2Fx	-Fb/EJ	-1/2Fx+Fx ² /b	1/2Fx/EJ	1/4x ² /b ²	(1/12+1/4)Fb ² /EJ	1/12Xb/EJ	
GF b	1/2-1/2x/b	Fb-2Fx	Fb/EJ	1/2Fb-3/2Fx+Fx ² /b	1/2Fb/EJ-1/2Fx/EJ	1/4-1/2x/b+1/4x ² /b ²			
GD b	-1+x/b	-Fx	0	Fx-Fx ² /b	0	1-2x/b+x ² /b ²	(1/6+0)Fb ² /EJ	1/3Xb/EJ	
DG b	x/b	Fb-Fx	0	Fx-Fx ² /b	0	x ² /b ²			
DH b	0	-3/2Fb+2Fx-1/2qx ²	0	0	0	0	0+0	0	
HD b	0	Fx+1/2qx ²	0	0	0	0			
GA b	1/2-1/2x/b	-Fb+Fx	0	-1/2Fb+Fx-1/2Fx ² /b	0	1/4-1/2x/b+1/4x ² /b ²	(-1/6+0)Fb ² /EJ	1/12Xb/EJ	
AG b	-1/2x/b	Fx	0	-1/2Fx ² /b	0	1/4x ² /b ²			
	totali							1/3Fb ² /EJ	1/2Xb/EJ
	iperstatica $X=W_{GD}$							-2/3Fb	

Sviluppi di calcolo iperstatica

$$L_{FG}^{xx} = \int_0^b (1/4 x^2/b^2) 1/EJ dx = [1/12 x^3/b^2]_0^b 1/EJ$$

$$= (1/12 b) 1/EJ = 1/12 b/EJ$$

$$L_{GF}^{xx} = \int_0^b (1/4 - 1/2 x/b + 1/4 x^2/b^2) 1/EJ dx = [1/4 x - 1/4 x^2/b + 1/12 x^3/b^2]_0^b 1/EJ$$

$$= (1/4 b - 1/4 b + 1/12 b) 1/EJ = 1/12 b/EJ$$

$$L_{GD}^{xx} = \int_0^b (1 - 2 x/b + x^2/b^2) 1/EJ dx = [x - x^2/b + 1/3 x^3/b^2]_0^b 1/EJ$$

$$= (b - b + 1/3 b) 1/EJ = 1/3 b/EJ$$

$$L_{DG}^{xx} = \int_0^b (x^2/b^2) 1/EJ dx = [1/3 x^3/b^2]_0^b 1/EJ$$

$$= (1/3 b) 1/EJ = 1/3 b/EJ$$

$$L_{GA}^{xx} = \int_0^b (1/4 - 1/2 x/b + 1/4 x^2/b^2) 1/EJ dx = [1/4 x - 1/4 x^2/b + 1/12 x^3/b^2]_0^b 1/EJ$$

$$= (1/4 b - 1/4 b + 1/12 b) 1/EJ = 1/12 b/EJ$$

$$L_{AG}^{xx} = \int_0^b (1/4 x^2/b^2) 1/EJ dx = [1/12 x^3/b^2]_0^b 1/EJ$$

$$= (1/12 b) 1/EJ = 1/12 b/EJ$$

$$L_{FG}^{xo} = \int_0^b (-1/2 x/b + x^2/b^2) Fb 1/EJ dx + \int_0^b (1/2 x/b) \theta dx$$

$$= [-1/4 x^2/b + 1/3 x^3/b^2]_0^b Fb 1/EJ + [1/4 x^2/b]_0^b \theta$$

$$= (-1/4 b + 1/3 b) Fb 1/EJ + (1/4 b) \theta = 1/3 Fb^2/EJ$$

$$L_{GF}^{xo} = \int_0^b (1/2 - 3/2 x/b + x^2/b^2) Fb 1/EJ dx + \int_0^b (-1/2 + 1/2 x/b) \theta dx$$

$$= [1/2 x - 3/4 x^2/b + 1/3 x^3/b^2]_0^b Fb 1/EJ + [-1/2 x + 1/4 x^2/b]_0^b \theta$$

$$= (1/2 b - 3/4 b + 1/3 b) Fb 1/EJ + (-1/2 b + 1/4 b) \theta = 1/3 Fb^2/EJ$$

$$L_{GD}^{xo} = \int_0^b (x/b - x^2/b^2) Fb 1/EJ dx = [1/2 x^2/b - 1/3 x^3/b^2]_0^b Fb 1/EJ$$

$$= (1/2 b - 1/3 b) Fb 1/EJ = 1/6 Fb^2/EJ$$

$$L_{DG}^{xo} = \int_0^b (x/b - x^2/b^2) Fb 1/EJ dx = [1/2 x^2/b - 1/3 x^3/b^2]_0^b Fb 1/EJ$$

$$= (1/2 b - 1/3 b) Fb 1/EJ = 1/6 Fb^2/EJ$$

$$L_{GA}^{xo} = \int_0^b (-1/2 + x/b - 1/2 x^2/b^2) Fb 1/EJ dx = [-1/2 x + 1/2 x^2/b - 1/6 x^3/b^2]_0^b Fb 1/EJ$$

$$= (-1/2 b + 1/2 b - 1/6 b) Fb 1/EJ = -1/6 Fb^2/EJ$$

$$L_{AG}^{xo} = \int_0^b (-1/2 x^2/b^2) Fb 1/EJ dx = [-1/6 x^3/b^2]_0^b Fb 1/EJ$$

$$= (-1/6 b) Fb 1/EJ = -1/6 Fb^2/EJ$$

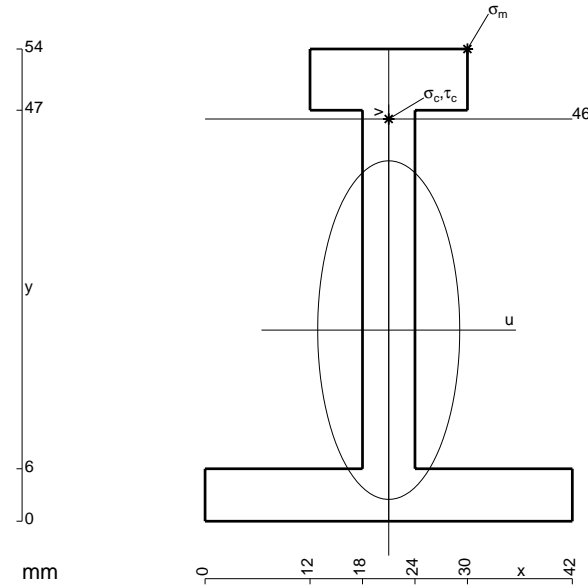

- A = 624. mm²
- J_u = 234015. mm⁴
- J_v = 41184. mm⁴
- y_g = 21.86 mm
- T_y = -2460. N
- M_x = -1746600. Nmm
- x_m = 30. mm
- y_m = 54. mm
- u_m = 9. mm
- v_m = 32.14 mm
- σ_m = -Mv/J_u = 239.9 N/mm²
- x_c = 21. mm
- y_c = 46. mm
- v_c = 24.14 mm
- σ_c = -Mv/J_u = 180.2 N/mm²
- τ_c = 6.582 N/mm²
- σ_o = √σ²+3τ² = 180.6 N/mm²
- S = 3757. mm³

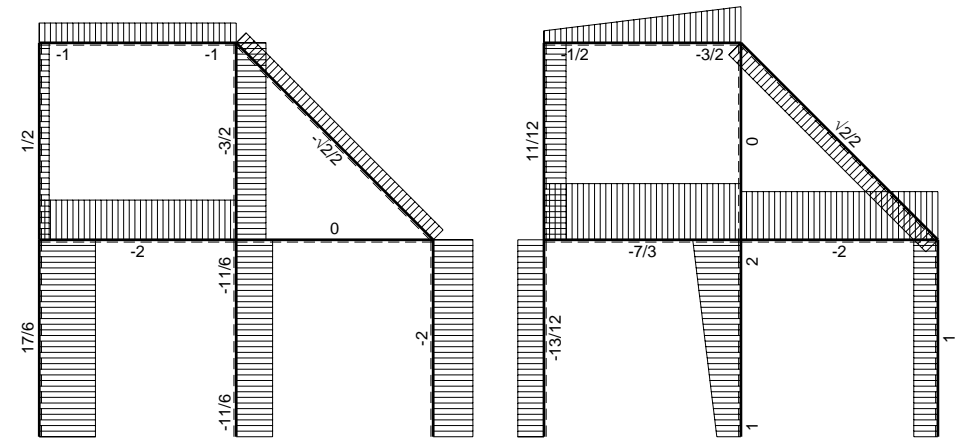
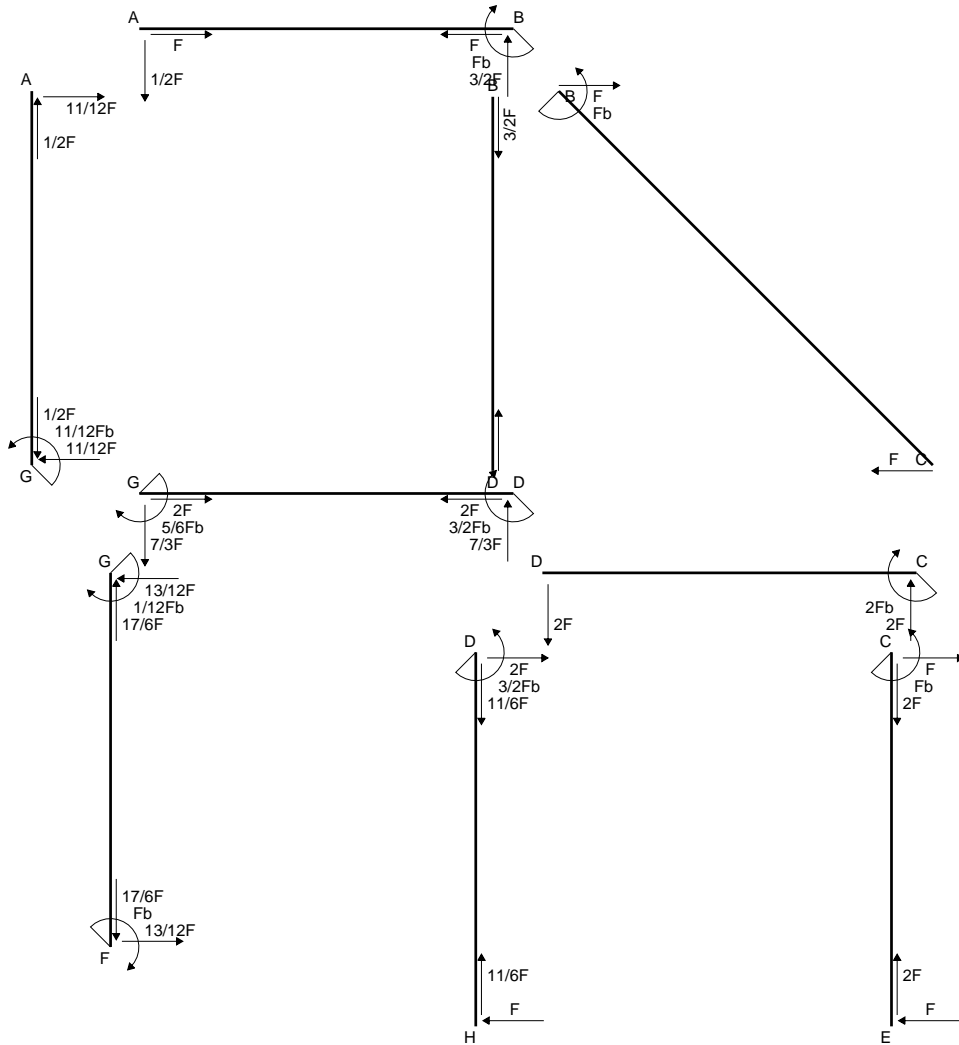

← ⊕ → F

↑ ⊕ ↓ F

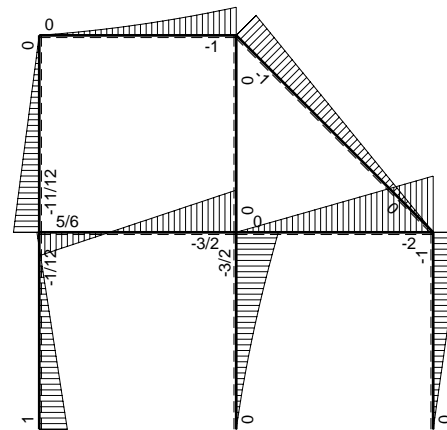

⊕ ⊖ F_b

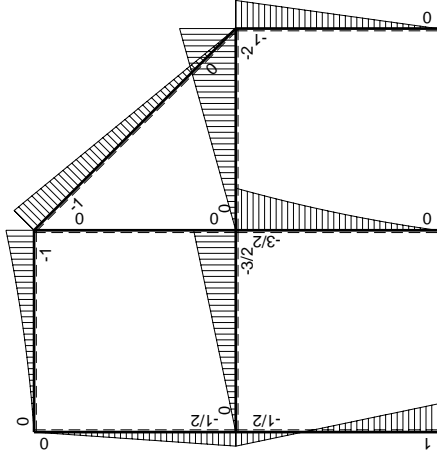
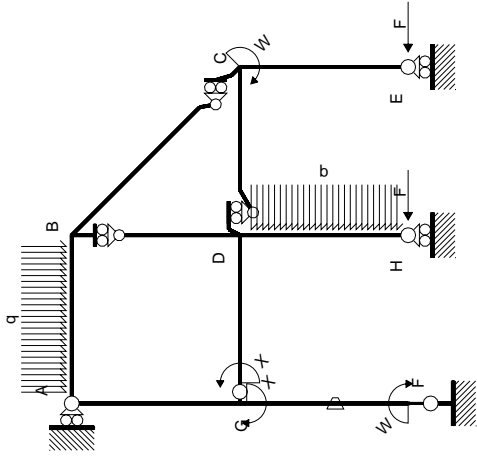

Schema di calcolo iperstatico

M_0 flessione da carichi assegnati

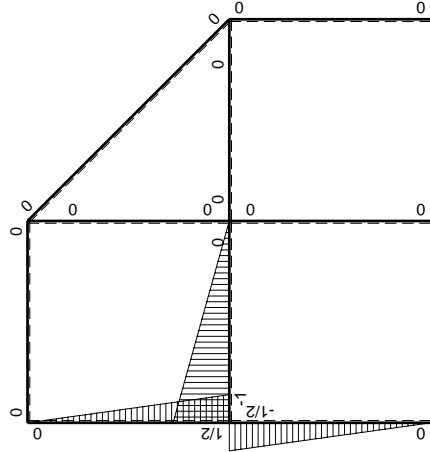

M_x flessione da iperstatica X=1

Quadro contributi PLV per iperstatica $X=W_{GD}$

→	$M_x(x)$	$M_o(x)$	θ	$M_x M_o$	$M_x \theta$	$M_x M_x$	$\int M_x(M_o/EJ+\theta)dx$	$\int X M_x M_x/EJdx$
AB b	0	$-1/2Fx-1/2qx^2$	0	0	0	0	0+0	0
BA b	0	$Fb-3/2Fx+1/2qx^2$	0	0	0	0		
BC $\sqrt{2}b$	0	$-Fb+\sqrt{2}/2Fx$	0	0	0	0	0	0
BD b	0	0	0	0	0	0	0+0	0
DB b	0	0	0	0	0	0		
DC b	0	$-2Fx$	0	0	0	0	0+0	0
CD b	0	$2Fb-2Fx$	0	0	0	0		
CE b	0	$-Fb+Fx$	0	0	0	0	0+0	0
EC b	0	Fx	0	0	0	0		
FG b	$-1/2x/b$	$Fb-3/2Fx$	$-Fb/EJ$	$-1/2Fx+3/4Fx^2/b$	$1/2Fx/EJ$	$1/4x^2/b^2$	$(0+1/4)Fb^2/EJ$	$1/12Xb/EJ$
GF b	$1/2-1/2x/b$	$1/2Fb-3/2Fx$	Fb/EJ	$1/4Fb-Fx+3/4Fx^2/b$	$1/2Fb/EJ-1/2Fx/EJ$	$1/4-1/2x/b+1/4x^2/b^2$		
GD b	$-1+x/b$	$-3/2Fx$	0	$3/2Fx-3/2Fx^2/b$	0	$1-2x/b+x^2/b^2$	$(1/4+0)Fb^2/EJ$	$1/3Xb/EJ$
DG b	x/b	$3/2Fb-3/2Fx$	0	$3/2Fx-3/2Fx^2/b$	0	x^2/b^2		
DH b	0	$-3/2Fb+2Fx-1/2qx^2$	0	0	0	0	0+0	0
HD b	0	$Fx+1/2qx^2$	0	0	0	0		
GA b	$1/2-1/2x/b$	$-1/2Fb+1/2Fx$	0	$-1/4Fb+1/2Fx-1/4Fx^2/b$	0	$1/4-1/2x/b+1/4x^2/b^2$	$(-1/12+0)Fb^2/EJ$	$1/12Xb/EJ$
AG b	$-1/2x/b$	$1/2Fx$	0	$-1/4Fx^2/b$	0	$1/4x^2/b^2$		
	totali						$5/12Fb^2/EJ$	$1/2Xb/EJ$
	iperstatica $X=W_{GD}$						$-5/6Fb$	

Sviluppi di calcolo iperstatica

$$L_{FG}^{xx} = \int_0^b (1/4 x^2/b^2) 1/EJ dx = [1/12 x^3/b^2]_0^b 1/EJ$$

$$= (1/12 b) 1/EJ = 1/12 b/EJ$$

$$L_{GF}^{xx} = \int_0^b (1/4 - 1/2 x/b + 1/4 x^2/b^2) 1/EJ dx = [1/4 x - 1/4 x^2/b + 1/12 x^3/b^2]_0^b 1/EJ$$

$$= (1/4 b - 1/4 b + 1/12 b) 1/EJ = 1/12 b/EJ$$

$$L_{GD}^{xx} = \int_0^b (1 - 2 x/b + x^2/b^2) 1/EJ dx = [x - x^2/b + 1/3 x^3/b^2]_0^b 1/EJ$$

$$= (b - b + 1/3 b) 1/EJ = 1/3 b/EJ$$

$$L_{DG}^{xx} = \int_0^b (x^2/b^2) 1/EJ dx = [1/3 x^3/b^2]_0^b 1/EJ$$

$$= (1/3 b) 1/EJ = 1/3 b/EJ$$

$$L_{GA}^{xx} = \int_0^b (1/4 - 1/2 x/b + 1/4 x^2/b^2) 1/EJ dx = [1/4 x - 1/4 x^2/b + 1/12 x^3/b^2]_0^b 1/EJ$$

$$= (1/4 b - 1/4 b + 1/12 b) 1/EJ = 1/12 b/EJ$$

$$L_{AG}^{xx} = \int_0^b (1/4 x^2/b^2) 1/EJ dx = [1/12 x^3/b^2]_0^b 1/EJ$$

$$= (1/12 b) 1/EJ = 1/12 b/EJ$$

$$L_{FG}^{xo} = \int_0^b (-1/2 x/b + 3/4 x^2/b^2) Fb 1/EJ dx + \int_0^b (1/2 x/b) \theta dx$$

$$= [-1/4 x^2/b + 1/4 x^3/b^2]_0^b Fb 1/EJ + [1/4 x^2/b]_0^b \theta$$

$$= (-1/4 b + 1/4 b) Fb 1/EJ + (1/4 b) \theta = 1/4 Fb^2/EJ$$

$$L_{GF}^{xo} = \int_0^b (1/4 - x/b + 3/4 x^2/b^2) Fb 1/EJ dx + \int_0^b (-1/2 + 1/2 x/b) \theta dx$$

$$= [1/4 x - 1/2 x^2/b + 1/4 x^3/b^2]_0^b Fb 1/EJ + [-1/2 x + 1/4 x^2/b]_0^b \theta$$

$$= (1/4 b - 1/2 b + 1/4 b) Fb 1/EJ + (-1/2 b + 1/4 b) \theta = 1/4 Fb^2/EJ$$

$$L_{GD}^{xo} = \int_0^b (3/2 x/b - 3/2 x^2/b^2) Fb 1/EJ dx = [3/4 x^2/b - 1/2 x^3/b^2]_0^b Fb 1/EJ$$

$$= (3/4 b - 1/2 b) Fb 1/EJ = 1/4 Fb^2/EJ$$

$$L_{DG}^{xo} = \int_0^b (3/2 x/b - 3/2 x^2/b^2) Fb 1/EJ dx = [3/4 x^2/b - 1/2 x^3/b^2]_0^b Fb 1/EJ$$

$$= (3/4 b - 1/2 b) Fb 1/EJ = 1/4 Fb^2/EJ$$

$$L_{GA}^{xo} = \int_0^b (-1/4 + 1/2 x/b - 1/4 x^2/b^2) Fb 1/EJ dx = [-1/4 x + 1/4 x^2/b - 1/12 x^3/b^2]_0^b Fb 1/EJ$$

$$= (-1/4 b + 1/4 b - 1/12 b) Fb 1/EJ = -1/12 Fb^2/EJ$$

$$L_{AG}^{xo} = \int_0^b (-1/4 x^2/b^2) Fb 1/EJ dx = [-1/12 x^3/b^2]_0^b Fb 1/EJ$$

$$= (-1/12 b) Fb 1/EJ = -1/12 Fb^2/EJ$$

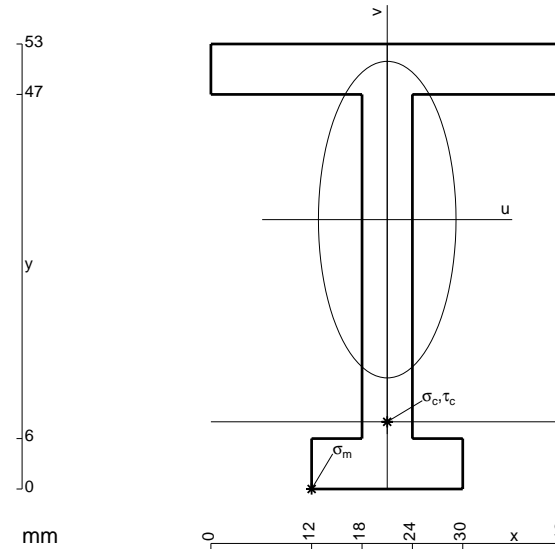

$$A = 606. \text{ mm}^2$$

$$J_u = 215454. \text{ mm}^4$$

$$J_v = 40698. \text{ mm}^4$$

$$y_g = 32.08 \text{ mm}$$

$$T_y = -1780. \text{ N}$$

$$M_x = -1335000. \text{ Nmm}$$

$$x_m = 12. \text{ mm}$$

$$u_m = -9. \text{ mm}$$

$$v_m = -32.08 \text{ mm}$$

$$\sigma_m = -Mv/J_u = -198.8 \text{ N/mm}^2$$

$$x_c = 21. \text{ mm}$$

$$y_c = 8. \text{ mm}$$

$$v_c = -24.08 \text{ mm}$$

$$\sigma_c = -Mv/J_u = -149.2 \text{ N/mm}^2$$

$$\tau_c = 4.74 \text{ N/mm}^2$$

$$\sigma_q = \sqrt{\sigma^2 + 3\tau^2} = 149.5 \text{ N/mm}^2$$

$$S = 3442. \text{ mm}^3$$

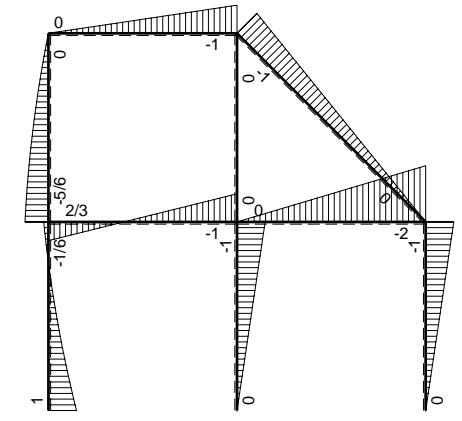
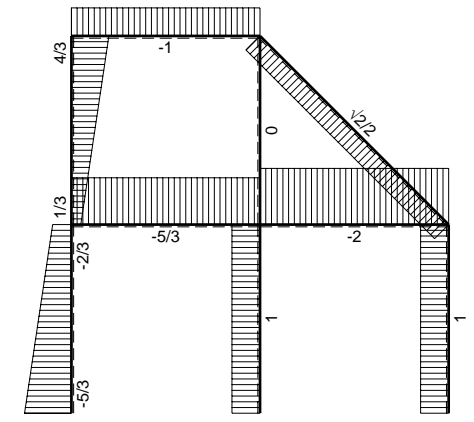
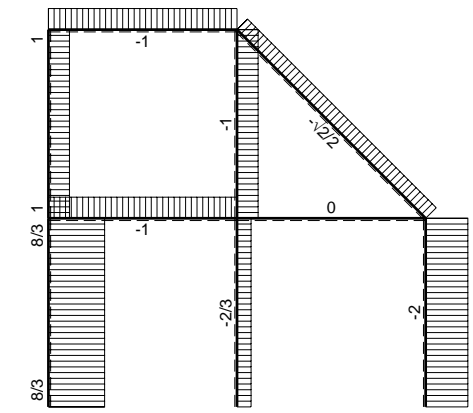
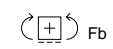
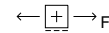
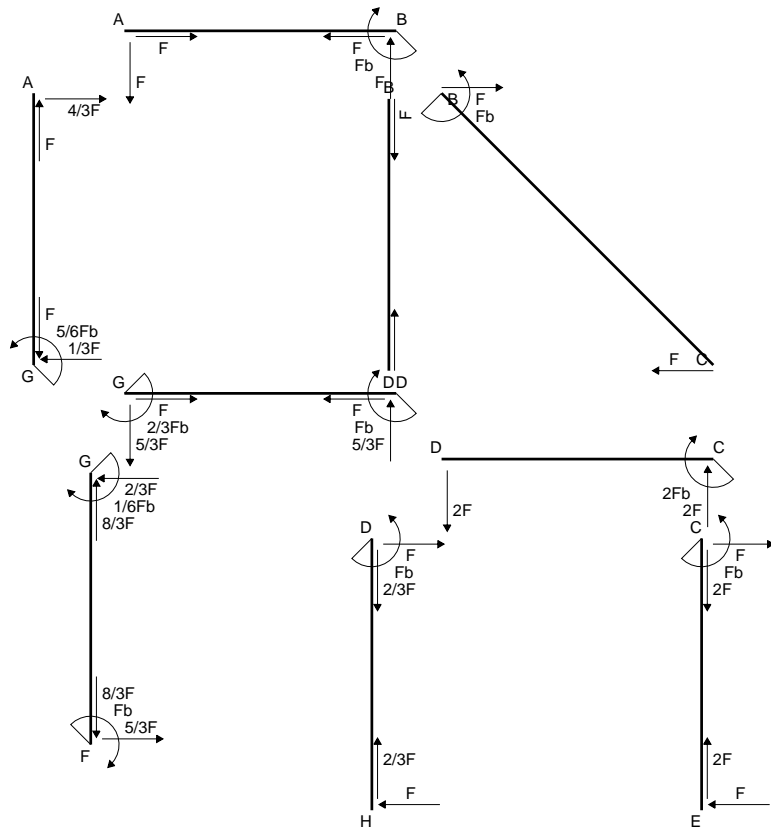

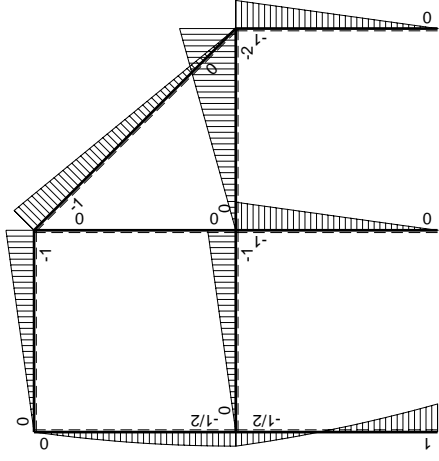
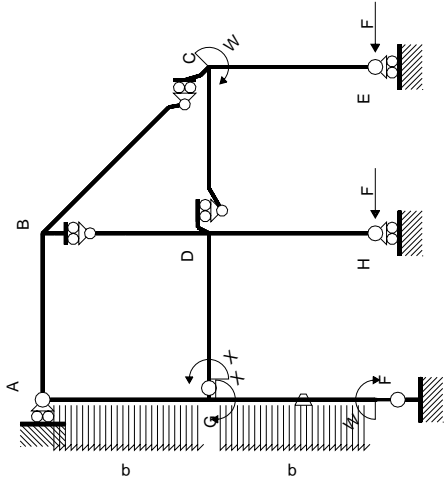

Schema di calcolo iperstatico

M_0 flessione da carichi assegnati

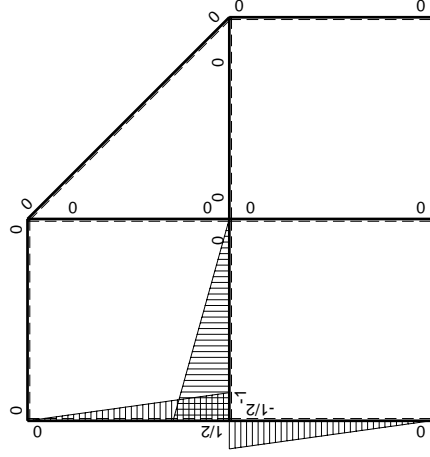

M_x flessione da iperstatica $X=1$

Quadro contributi PLV per iperstatica $X=W_{GD}$

→	$M_x(x)$	$M_o(x)$	θ	$M_x M_o$	$M_x \theta$	$M_x M_x$	$\int M_x(M_o/EJ+\theta)dx$	$\int X M_x M_x/EJdx$	
AB b	0	-Fx	0	0	0	0	0+0	0	
BA b	0	Fb-Fx	0	0	0	0			
BC $\sqrt{2}b$	0	-Fb+ $\sqrt{2}/2Fx$	0	0	0	0	0	0	
BD b	0	0	0	0	0	0	0+0	0	
DB b	0	0	0	0	0	0			
DC b	0	-2Fx	0	0	0	0	0+0	0	
CD b	0	2Fb-2Fx	0	0	0	0			
CE b	0	-Fb+Fx	0	0	0	0	0+0	0	
EC b	0	Fx	0	0	0	0			
FG b	-1/2x/b	Fb-2Fx+1/2qx ²	-Fb/EJ	-1/2Fx+Fx ² /b-1/4qx ³ /b	1/2Fx/EJ	1/4x ² /b ²	(1/48+1/4)Fb ² /EJ	1/12Xb/EJ	
GF b	1/2-1/2x/b	1/2Fb-Fx-1/2qx ²	Fb/EJ	1/4Fb-3/4Fx+1/4Fx ² /b+1/4qx ³ /b	1/2Fb/EJ-1/2Fx/EJ	1/4-1/2x/b+1/4x ² /b ²			
GD b	-1+x/b	-Fx	0	Fx-Fx ² /b	0	1-2x/b+x ² /b ²	(1/6+0)Fb ² /EJ	1/3Xb/EJ	
DG b	x/b	Fb-Fx	0	Fx-Fx ² /b	0	x ² /b ²			
DH b	0	-Fb+Fx	0	0	0	0	0+0	0	
HD b	0	Fx	0	0	0	0			
GA b	1/2-1/2x/b	-1/2Fb+1/2qx ²	0	-1/4Fb+1/4Fx+1/4Fx ² /b-1/4qx ³ /b	0	1/4-1/2x/b+1/4x ² /b ²	(-5/48+0)Fb ² /EJ	1/12Xb/EJ	
AG b	-1/2x/b	Fx-1/2qx ²	0	-1/2Fx ² /b+1/4qx ³ /b	0	1/4x ² /b ²			
	totali							1/3Fb ² /EJ	1/2Xb/EJ
	iperstatica $X=W_{GD}$							-2/3Fb	

Sviluppi di calcolo iperstatica

$$L_{FG}^{xx} = \int_0^b (1/4 x^2/b^2) 1/EJ dx = [1/12 x^3/b^2]_0^b 1/EJ$$

$$= (1/12 b) 1/EJ = 1/12 b/EJ$$

$$L_{GF}^{xx} = \int_0^b (1/4 - 1/2 x/b + 1/4 x^2/b^2) 1/EJ dx = [1/4 x - 1/4 x^2/b + 1/12 x^3/b^2]_0^b 1/EJ$$

$$= (1/4 b - 1/4 b + 1/12 b) 1/EJ = 1/12 b/EJ$$

$$L_{GD}^{xx} = \int_0^b (1/2 - x/b + x^2/b^2) 1/EJ dx = [x - x^2/b + 1/3 x^3/b^2]_0^b 1/EJ$$

$$= (b - b + 1/3 b) 1/EJ = 1/3 b/EJ$$

$$L_{DG}^{xx} = \int_0^b (x^2/b^2) 1/EJ dx = [1/3 x^3/b^2]_0^b 1/EJ$$

$$= (1/3 b) 1/EJ = 1/3 b/EJ$$

$$L_{GA}^{xx} = \int_0^b (1/4 - 1/2 x/b + 1/4 x^2/b^2) 1/EJ dx = [1/4 x - 1/4 x^2/b + 1/12 x^3/b^2]_0^b 1/EJ$$

$$= (1/4 b - 1/4 b + 1/12 b) 1/EJ = 1/12 b/EJ$$

$$L_{AG}^{xx} = \int_0^b (1/4 x^2/b^2) 1/EJ dx = [1/12 x^3/b^2]_0^b 1/EJ$$

$$= (1/12 b) 1/EJ = 1/12 b/EJ$$

$$L_{FG}^{xo} = \int_0^b (-1/2 x/b + x^2/b^2 - 1/4 x^3/b^3) Fb 1/EJ dx + \int_0^b (1/2 x/b) \theta dx$$

$$= [-1/4 x^2/b + 1/3 x^3/b^2 - 1/16 x^4/b^3]_0^b Fb 1/EJ + [1/4 x^2/b]_0^b \theta$$

$$= (-1/4 b + 1/3 b - 1/16 b) Fb 1/EJ + (1/4 b) \theta = 13/48 Fb^2/EJ$$

$$L_{GF}^{xo} = \int_0^b (1/4 - 3/4 x/b + 1/4 x^2/b^2 + 1/4 x^3/b^3) Fb 1/EJ dx + \int_0^b (-1/2 + 1/2 x/b) \theta dx$$

$$= [1/4 x - 3/8 x^2/b + 1/12 x^3/b^2 + 1/16 x^4/b^3]_0^b Fb 1/EJ + [-1/2 x + 1/4 x^2/b]_0^b \theta$$

$$= (1/4 b - 3/8 b + 1/12 b + 1/16 b) Fb 1/EJ + (-1/2 b + 1/4 b) \theta = 13/48 Fb^2/EJ$$

$$L_{GD}^{xo} = \int_0^b (x/b - x^2/b^2) Fb 1/EJ dx = [1/2 x^2/b - 1/3 x^3/b^2]_0^b Fb 1/EJ$$

$$= (1/2 b - 1/3 b) Fb 1/EJ = 1/6 Fb^2/EJ$$

$$L_{DG}^{xo} = \int_0^b (x/b - x^2/b^2) Fb 1/EJ dx = [1/2 x^2/b - 1/3 x^3/b^2]_0^b Fb 1/EJ$$

$$= (1/2 b - 1/3 b) Fb 1/EJ = 1/6 Fb^2/EJ$$

$$L_{GA}^{xo} = \int_0^b (-1/4 + 1/4 x/b + 1/4 x^2/b^2 - 1/4 x^3/b^3) Fb 1/EJ dx$$

$$= [-1/4 x + 1/8 x^2/b + 1/12 x^3/b^2 - 1/16 x^4/b^3]_0^b Fb 1/EJ$$

$$= (-1/4 b + 1/8 b + 1/12 b - 1/16 b) Fb 1/EJ = -5/48 Fb^2/EJ$$

$$L_{AG}^{xo} = \int_0^b (-1/2 x^2/b^2 + 1/4 x^3/b^3) Fb 1/EJ dx = [-1/6 x^3/b^2 + 1/16 x^4/b^3]_0^b Fb 1/EJ$$

$$= (-1/6 b + 1/16 b) Fb 1/EJ = -5/48 Fb^2/EJ$$

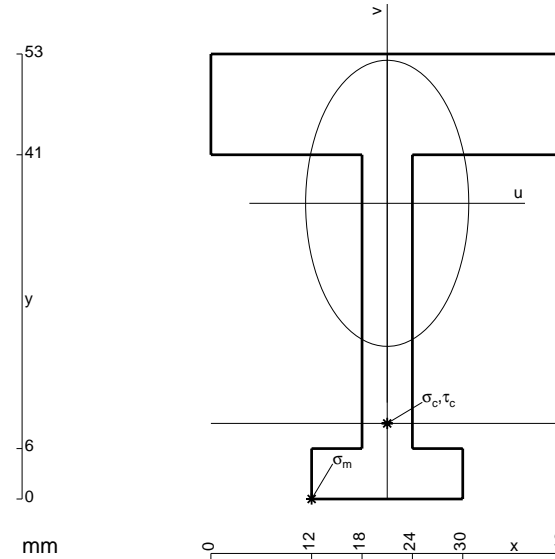

- A = 822. mm²
- J_u = 238712. mm⁴
- J_v = 77634. mm⁴
- y_g = 35.22 mm
- T_y = -1760. N
- M_x = -1408000. Nmm
- x_m = 12. mm
- u_m = -9. mm
- v_m = -35.22 mm
- σ_m = -Mv/J_u = -207.7 N/mm²
- x_c = 21. mm
- y_c = 9. mm
- v_c = -26.22 mm
- σ_c = -Mv/J_u = -154.6 N/mm²
- τ_c = 4.888 N/mm²
- σ_q = √σ²+3τ² = 154.9 N/mm²
- S = 3978. mm³

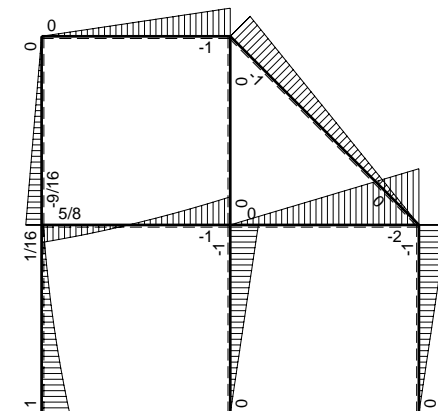
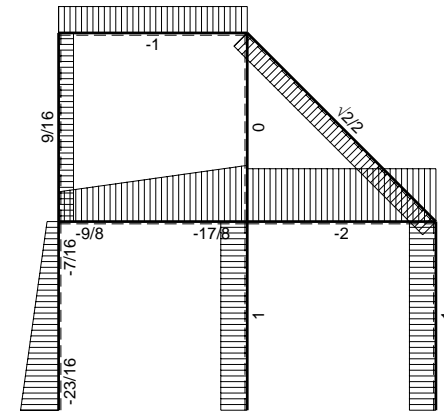
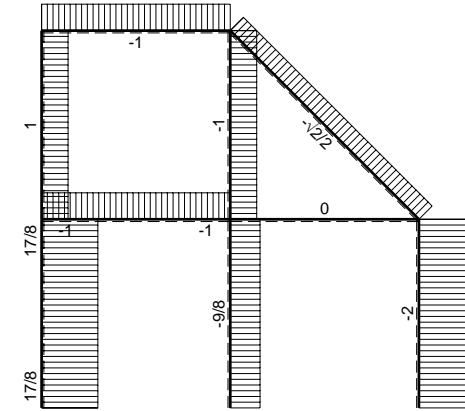
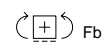
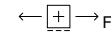
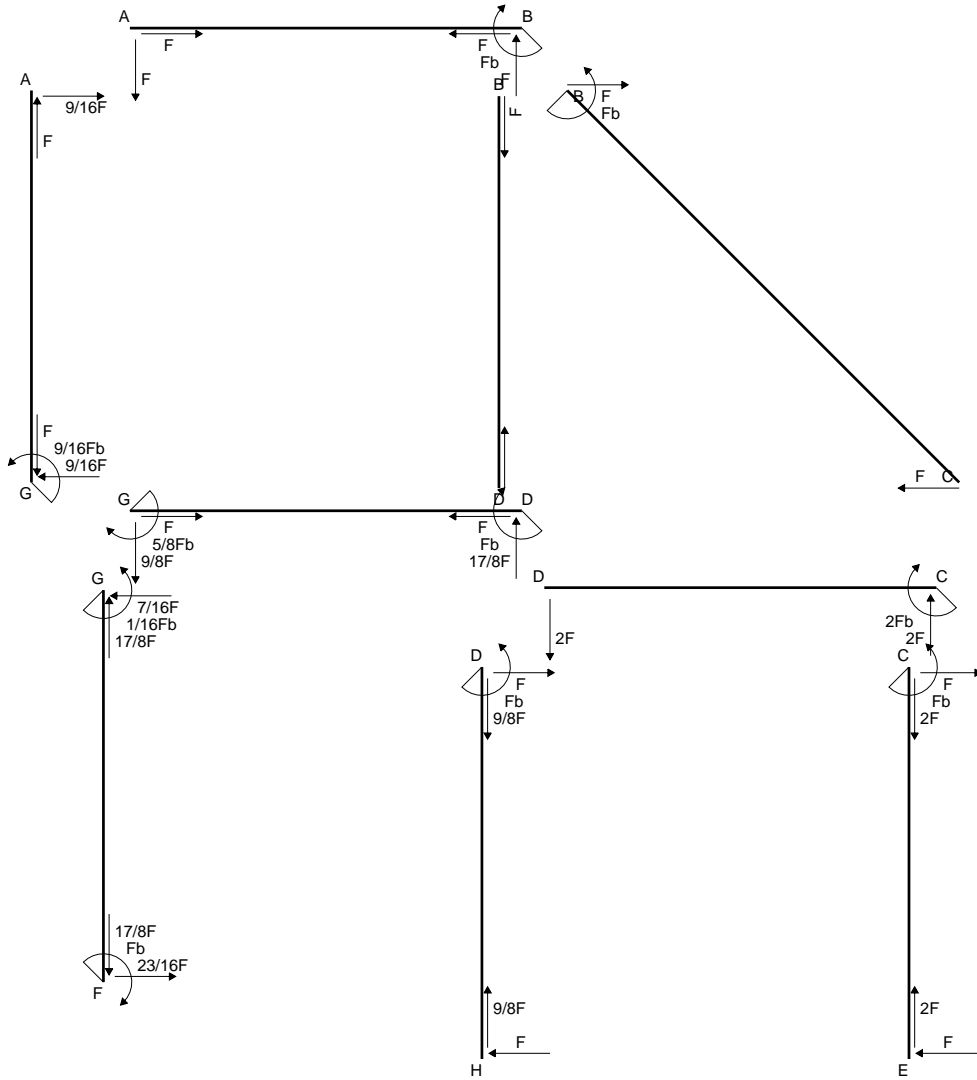

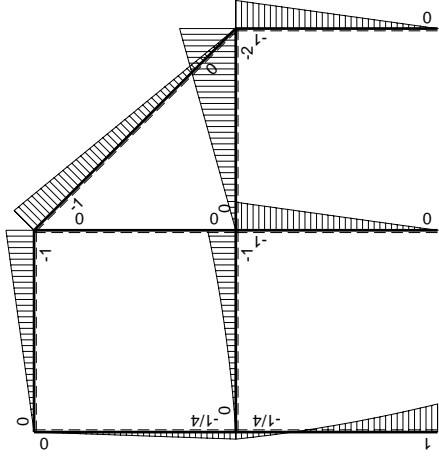
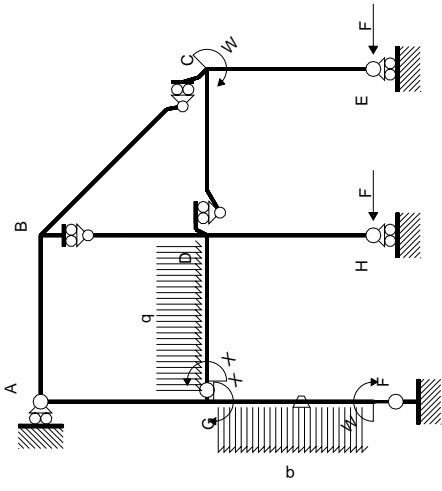

Schema di calcolo iperstatico

M_0 flessione da carichi assegnati



M_x flessione da iperstatica $X=1$

Quadro contributi PLV per iperstatica $X=W_{GD}$

→	$M_x(x)$	$M_o(x)$	θ	$M_x M_o$	$M_x \theta$	$M_x M_x$	$\int M_x(M_o/EJ+\theta)dx$	$\int X M_x M_x/EJ dx$
AB b	0	-Fx	0	0	0	0	0+0	0
BA b	0	Fb-Fx	0	0	0	0	0	0
BC $\sqrt{2}b$	0	-Fb+ $\sqrt{2}/2Fx$	0	0	0	0	0	0
BD b	0	0	0	0	0	0	0+0	0
DB b	0	0	0	0	0	0	0	0
DC b	0	-2Fx	0	0	0	0	0+0	0
CD b	0	2Fb-2Fx	0	0	0	0	0	0
CE b	0	-Fb+Fx	0	0	0	0	0+0	0
EC b	0	Fx	0	0	0	0	0	0
FG b	-1/2x/b	Fb-7/4Fx+1/2qx ²	-Fb/EJ	-1/2Fx+7/8Fx ² /b-1/4qx ³ /b	1/2Fx/EJ	1/4x ² /b ²	(-1/48+1/4)Fb ² /EJ	1/12Xb/EJ
GF b	1/2-1/2x/b	1/4Fb-3/4Fx-1/2qx ²	Fb/EJ	1/8Fb-1/2Fx+1/8Fx ² /b+1/4qx ³ /b	1/2Fb/EJ-1/2Fx/EJ	1/4-1/2x/b+1/4x ² /b ²		
GD b	-1+x/b	-1/2Fx-1/2qx ²	0	1/2Fx-1/2qx ³ /b	0	1-2x/b+x ² /b ²	(1/8+0)Fb ² /EJ	1/3Xb/EJ
DG b	x/b	Fb-3/2Fx+1/2qx ²	0	Fx-3/2Fx ² /b+1/2qx ³ /b	0	x ² /b ²		
DH b	0	-Fb+Fx	0	0	0	0	0+0	0
HD b	0	Fx	0	0	0	0	0	0
GA b	1/2-1/2x/b	-1/4Fb+1/4Fx	0	-1/8Fb+1/4Fx-1/8Fx ² /b	0	1/4-1/2x/b+1/4x ² /b ²	(-1/24+0)Fb ² /EJ	1/12Xb/EJ
AG b	-1/2x/b	1/4Fx	0	-1/8Fx ² /b	0	1/4x ² /b ²		
	totali						5/16Fb ² /EJ	1/2Xb/EJ
	iperstatica $X=W_{GD}$						-5/8Fb	

Sviluppi di calcolo iperstatica

$$L_{FG}^{xx} = \int_0^b (1/4 x^2/b^2) 1/EJ dx = [1/12 x^3/b^2]_0^b 1/EJ$$

$$= (1/12 b) 1/EJ = 1/12 b/EJ$$

$$L_{GF}^{xx} = \int_0^b (1/4 - 1/2 x/b + 1/4 x^2/b^2) 1/EJ dx = [1/4 x - 1/4 x^2/b + 1/12 x^3/b^2]_0^b 1/EJ$$

$$= (1/4 b - 1/4 b + 1/12 b) 1/EJ = 1/12 b/EJ$$

$$L_{GD}^{xx} = \int_0^b (1 - 2 x/b + x^2/b^2) 1/EJ dx = [x - x^2/b + 1/3 x^3/b^2]_0^b 1/EJ$$

$$= (b - b + 1/3 b) 1/EJ = 1/3 b/EJ$$

$$L_{DG}^{xx} = \int_0^b (x^2/b^2) 1/EJ dx = [1/3 x^3/b^2]_0^b 1/EJ$$

$$= (1/3 b) 1/EJ = 1/3 b/EJ$$

$$L_{GA}^{xx} = \int_0^b (1/4 - 1/2 x/b + 1/4 x^2/b^2) 1/EJ dx = [1/4 x - 1/4 x^2/b + 1/12 x^3/b^2]_0^b 1/EJ$$

$$= (1/4 b - 1/4 b + 1/12 b) 1/EJ = 1/12 b/EJ$$

$$L_{AG}^{xx} = \int_0^b (1/4 x^2/b^2) 1/EJ dx = [1/12 x^3/b^2]_0^b 1/EJ$$

$$= (1/12 b) 1/EJ = 1/12 b/EJ$$

$$L_{FG}^{xo} = \int_0^b (-1/2 x/b + 7/8 x^2/b^2 - 1/4 x^3/b^3) Fb 1/EJ dx + \int_0^b (1/2 x/b) \theta dx$$

$$= [-1/4 x^2/b + 7/24 x^3/b^2 - 1/16 x^4/b^3]_0^b Fb 1/EJ + [1/4 x^2/b]_0^b \theta$$

$$= (-1/4 b + 7/24 b - 1/16 b) Fb 1/EJ + (1/4 b) \theta = 11/48 Fb^2/EJ$$

$$L_{GF}^{xo} = \int_0^b (1/8 - 1/2 x/b + 1/8 x^2/b^2 + 1/4 x^3/b^3) Fb 1/EJ dx + \int_0^b (-1/2 + 1/2 x/b) \theta dx$$

$$= [1/8 x - 1/4 x^2/b + 1/24 x^3/b^2 + 1/16 x^4/b^3]_0^b Fb 1/EJ + [-1/2 x + 1/4 x^2/b]_0^b \theta$$

$$= (1/8 b - 1/4 b + 1/24 b + 1/16 b) Fb 1/EJ + (-1/2 b + 1/4 b) \theta = 11/48 Fb^2/EJ$$

$$L_{GD}^{xo} = \int_0^b (1/2 x/b - 1/2 x^3/b^3) Fb 1/EJ dx = [1/4 x^2/b - 1/8 x^4/b^3]_0^b Fb 1/EJ$$

$$= (1/4 b - 1/8 b) Fb 1/EJ = 1/8 Fb^2/EJ$$

$$L_{DG}^{xo} = \int_0^b (x/b - 3/2 x^2/b^2 + 1/2 x^3/b^3) Fb 1/EJ dx = [1/2 x^2/b - 1/2 x^3/b^2 + 1/8 x^4/b^3]_0^b Fb 1/EJ$$

$$= (1/2 b - 1/2 b + 1/8 b) Fb 1/EJ = 1/8 Fb^2/EJ$$

$$L_{GA}^{xo} = \int_0^b (-1/8 + 1/4 x/b - 1/8 x^2/b^2) Fb 1/EJ dx = [-1/8 x + 1/8 x^2/b - 1/24 x^3/b^2]_0^b Fb 1/EJ$$

$$= (-1/8 b + 1/8 b - 1/24 b) Fb 1/EJ = -1/24 Fb^2/EJ$$

$$L_{AG}^{xo} = \int_0^b (-1/8 x^2/b^2) Fb 1/EJ dx = [-1/24 x^3/b^2]_0^b Fb 1/EJ$$

$$= (-1/24 b) Fb 1/EJ = -1/24 Fb^2/EJ$$

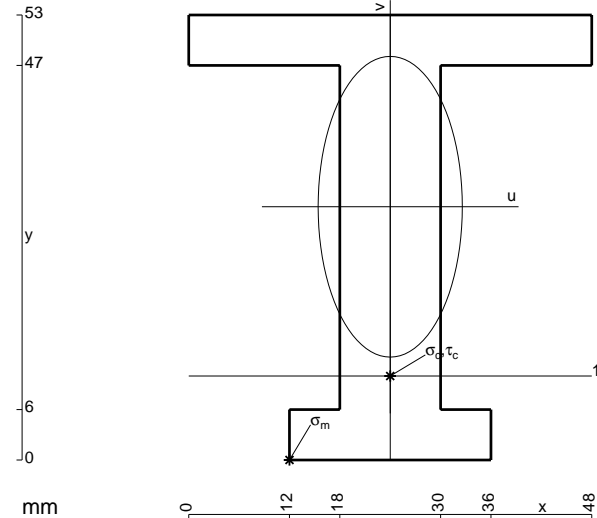

- A = 924. mm²
- J_u = 296396. mm⁴
- J_v = 68112. mm⁴
- y_g = 30.16 mm
- T_y = -2540. N
- M_x = -2159000. Nmm
- x_m = 12. mm
- u_m = -12. mm
- v_m = -30.16 mm
- σ_m = -Mv/J_u = -219.7 N/mm²
- x_c = 24. mm
- y_c = 10. mm
- v_c = -20.16 mm
- σ_c = -Mv/J_u = -146.9 N/mm²
- τ_c = 3.553 N/mm²
- σ_o = √σ²+3τ² = 147. N/mm²
- S = 4975. mm³

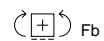
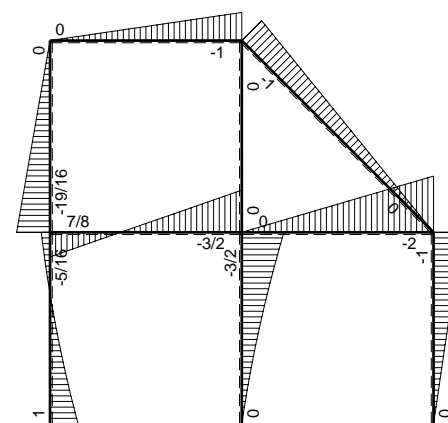
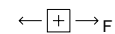
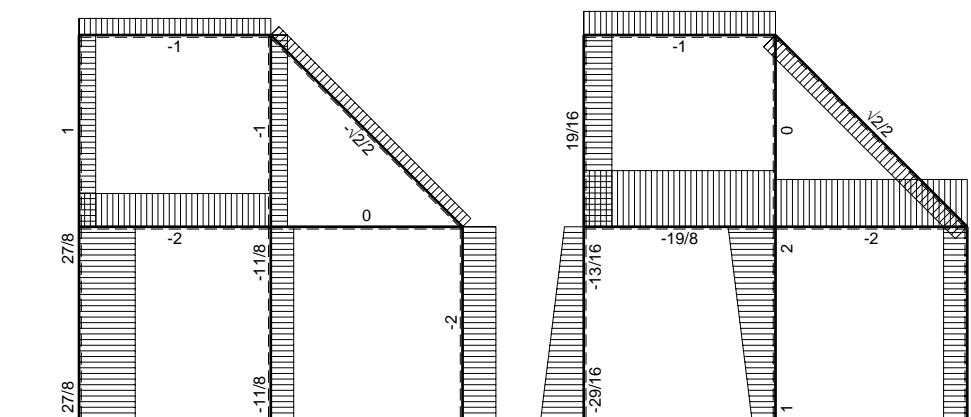
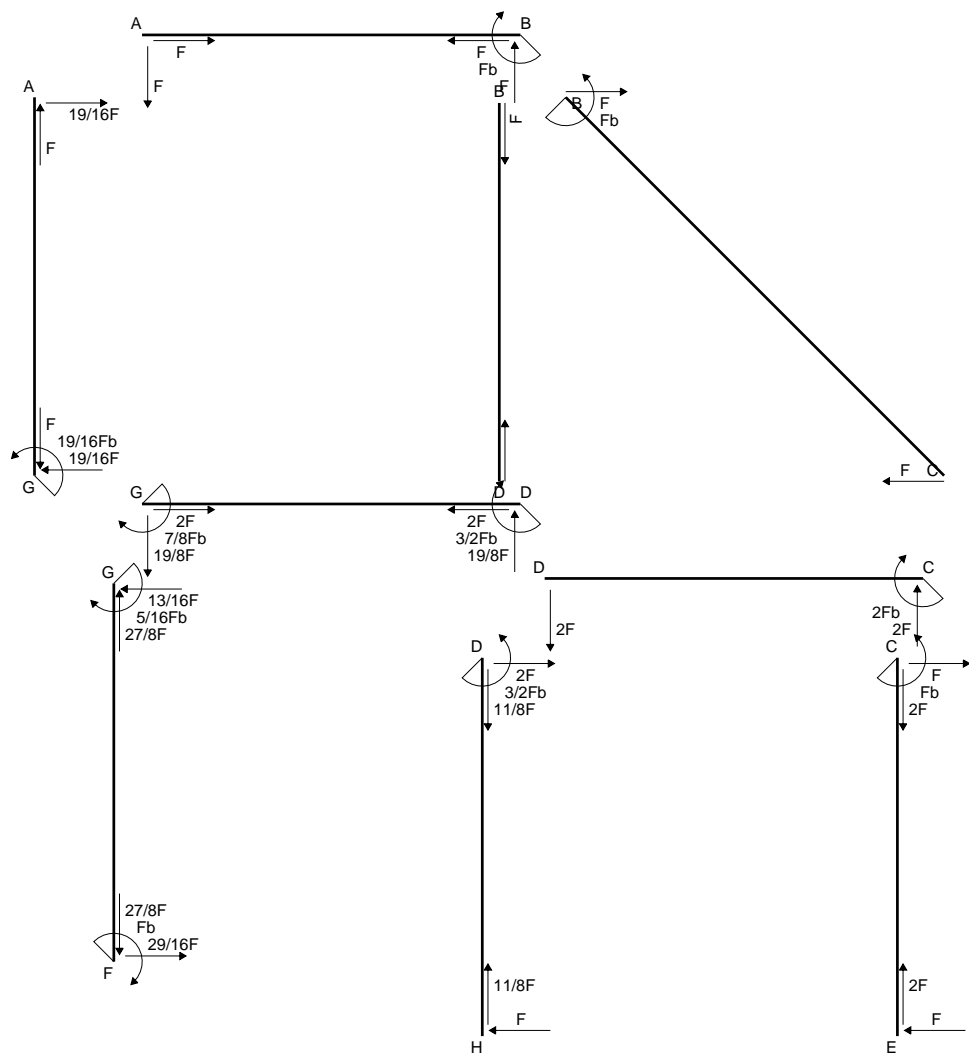

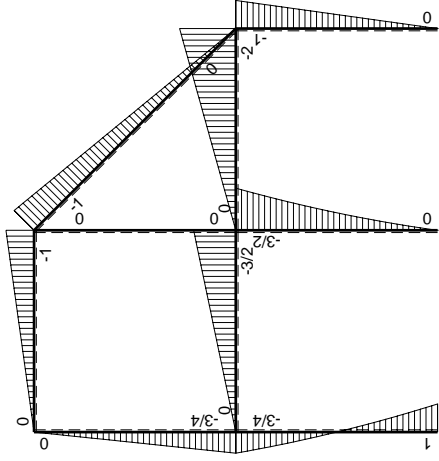
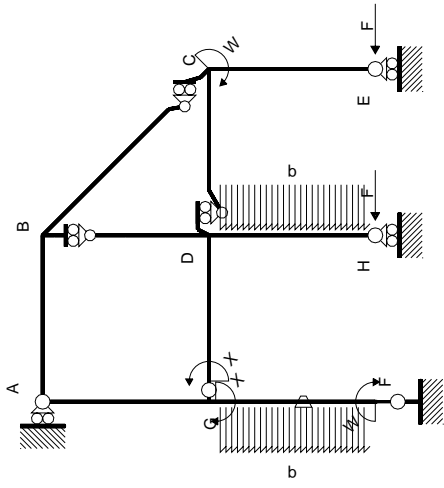

Schema di calcolo iperstatico

M_0 flessione da carichi assegnati

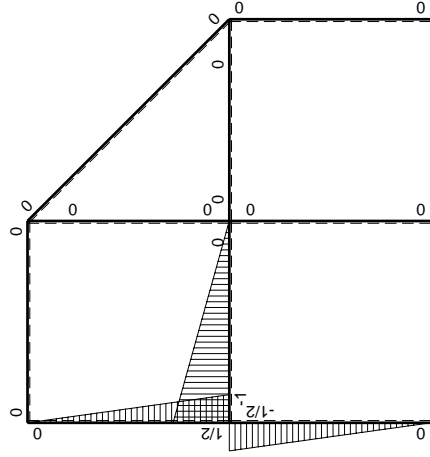

M_x flessione da iperstatica $X=1$

Quadro contributi PLV per iperstatica $X=W_{GD}$

→	$M_x(x)$	$M_o(x)$	θ	$M_x M_o$	$M_x \theta$	$M_x M_x$	$\int M_x(M_o/EJ+\theta)dx$	$\int X M_x M_x / EJ dx$
AB b	0	-Fx	0	0	0	0	0+0	0
BA b	0	Fb-Fx	0	0	0	0	0	0
BC $\sqrt{2}b$	0	-Fb+ $\sqrt{2}/2Fx$	0	0	0	0	0	0
BD b	0	0	0	0	0	0	0+0	0
DB b	0	0	0	0	0	0	0	0
DC b	0	-2Fx	0	0	0	0	0+0	0
CD b	0	2Fb-2Fx	0	0	0	0	0	0
CE b	0	-Fb+Fx	0	0	0	0	0+0	0
EC b	0	Fx	0	0	0	0	0	0
FG b	-1/2x/b	Fb-9/4Fx+1/2qx ²	-Fb/EJ	-1/2Fx+9/8Fx ² /b-1/4qx ³ /b	1/2Fx/EJ	1/4x ² /b ²	(1/16+1/4)Fb ² /EJ	1/12Xb/EJ
GF b	1/2-1/2x/b	3/4Fb-5/4Fx-1/2qx ²	Fb/EJ	3/8Fb-Fx+3/8Fx ² /b+1/4qx ³ /b	1/2Fb/EJ-1/2Fx/EJ	1/4-1/2x/b+1/4x ² /b ²		
GD b	-1+x/b	-3/2Fx	0	3/2Fx-3/2Fx ² /b	0	1-2x/b+x ² /b ²	(1/4+0)Fb ² /EJ	1/3Xb/EJ
DG b	x/b	3/2Fb-3/2Fx	0	3/2Fx-3/2Fx ² /b	0	x ² /b ²		
DH b	0	-3/2Fb+2Fx-1/2qx ²	0	0	0	0	0+0	0
HD b	0	Fx+1/2qx ²	0	0	0	0	0	0
GA b	1/2-1/2x/b	-3/4Fb+3/4Fx	0	-3/8Fb+3/4Fx-3/8Fx ² /b	0	1/4-1/2x/b+1/4x ² /b ²	(-1/8+0)Fb ² /EJ	1/12Xb/EJ
AG b	-1/2x/b	3/4Fx	0	-3/8Fx ² /b	0	1/4x ² /b ²		
	totali						7/16Fb ² /EJ	1/2Xb/EJ
	iperstatica $X=W_{GD}$						-7/8Fb	

Sviluppi di calcolo iperstatica

$$L_{FG}^{xx} = \int_0^b (1/4 x^2/b^2) 1/EJ dx = [1/12 x^3/b^2]_0^b 1/EJ$$

$$= (1/12 b) 1/EJ = 1/12 b/EJ$$

$$L_{GF}^{xx} = \int_0^b (1/4 - 1/2 x/b + 1/4 x^2/b^2) 1/EJ dx = [1/4 x - 1/4 x^2/b + 1/12 x^3/b^2]_0^b 1/EJ$$

$$= (1/4 b - 1/4 b + 1/12 b) 1/EJ = 1/12 b/EJ$$

$$L_{GD}^{xx} = \int_0^b (1 - 2 x/b + x^2/b^2) 1/EJ dx = [x - x^2/b + 1/3 x^3/b^2]_0^b 1/EJ$$

$$= (b - b + 1/3 b) 1/EJ = 1/3 b/EJ$$

$$L_{DG}^{xx} = \int_0^b (x^2/b^2) 1/EJ dx = [1/3 x^3/b^2]_0^b 1/EJ$$

$$= (1/3 b) 1/EJ = 1/3 b/EJ$$

$$L_{GA}^{xx} = \int_0^b (1/4 - 1/2 x/b + 1/4 x^2/b^2) 1/EJ dx = [1/4 x - 1/4 x^2/b + 1/12 x^3/b^2]_0^b 1/EJ$$

$$= (1/4 b - 1/4 b + 1/12 b) 1/EJ = 1/12 b/EJ$$

$$L_{AG}^{xx} = \int_0^b (1/4 x^2/b^2) 1/EJ dx = [1/12 x^3/b^2]_0^b 1/EJ$$

$$= (1/12 b) 1/EJ = 1/12 b/EJ$$

$$L_{FG}^{xo} = \int_0^b (-1/2 x/b + 9/8 x^2/b^2 - 1/4 x^3/b^3) Fb 1/EJ dx + \int_0^b (1/2 x/b) \theta dx$$

$$= [-1/4 x^2/b + 3/8 x^3/b^2 - 1/16 x^4/b^3]_0^b Fb 1/EJ + [1/4 x^2/b]_0^b \theta$$

$$= (-1/4 b + 3/8 b - 1/16 b) Fb 1/EJ + (1/4 b) \theta = 5/16 Fb^2/EJ$$

$$L_{GF}^{xo} = \int_0^b (3/8 - x/b + 3/8 x^2/b^2 + 1/4 x^3/b^3) Fb 1/EJ dx + \int_0^b (-1/2 + 1/2 x/b) \theta dx$$

$$= [3/8 x - 1/2 x^2/b + 1/8 x^3/b^2 + 1/16 x^4/b^3]_0^b Fb 1/EJ + [-1/2 x + 1/4 x^2/b]_0^b \theta$$

$$= (3/8 b - 1/2 b + 1/8 b + 1/16 b) Fb 1/EJ + (-1/2 b + 1/4 b) \theta = 5/16 Fb^2/EJ$$

$$L_{GD}^{xo} = \int_0^b (3/2 x/b - 3/2 x^2/b^2) Fb 1/EJ dx = [3/4 x^2/b - 1/2 x^3/b^2]_0^b Fb 1/EJ$$

$$= (3/4 b - 1/2 b) Fb 1/EJ = 1/4 Fb^2/EJ$$

$$L_{DG}^{xo} = \int_0^b (3/2 x/b - 3/2 x^2/b^2) Fb 1/EJ dx = [3/4 x^2/b - 1/2 x^3/b^2]_0^b Fb 1/EJ$$

$$= (3/4 b - 1/2 b) Fb 1/EJ = 1/4 Fb^2/EJ$$

$$L_{GA}^{xo} = \int_0^b (-3/8 + 3/4 x/b - 3/8 x^2/b^2) Fb 1/EJ dx = [-3/8 x + 3/8 x^2/b - 1/8 x^3/b^2]_0^b Fb 1/EJ$$

$$= (-3/8 b + 3/8 b - 1/8 b) Fb 1/EJ = -1/8 Fb^2/EJ$$

$$L_{AG}^{xo} = \int_0^b (-3/8 x^2/b^2) Fb 1/EJ dx = [-1/8 x^3/b^2]_0^b Fb 1/EJ$$

$$= (-1/8 b) Fb 1/EJ = -1/8 Fb^2/EJ$$

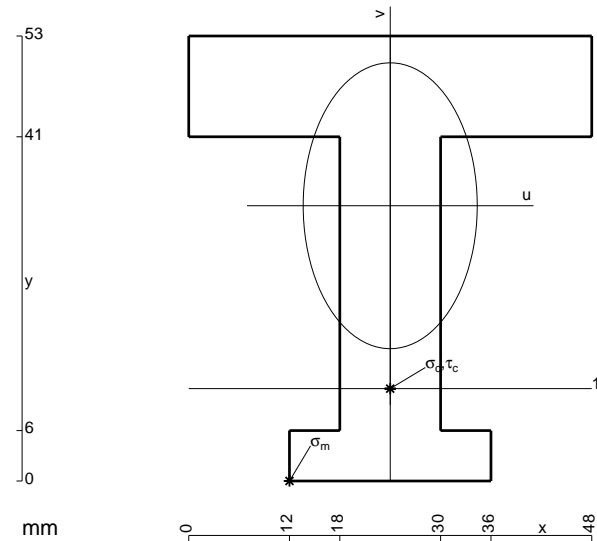

- A = 1140. mm²
- J_u = 330567. mm⁴
- J_v = 122544. mm⁴
- y_g = 32.78 mm
- T_y = -2560. N
- M_x = -2304000. Nmm
- x_m = 12. mm
- u_m = -12. mm
- v_m = -32.78 mm
- σ_m = -Mv/J_u = -228.5 N/mm²
- x_c = 24. mm
- y_c = 11. mm
- v_c = -21.78 mm
- σ_c = -Mv/J_u = -151.8 N/mm²
- τ_c = 3.708 N/mm²
- σ_o = √σ²+3τ² = 152. N/mm²
- S = 5746. mm³

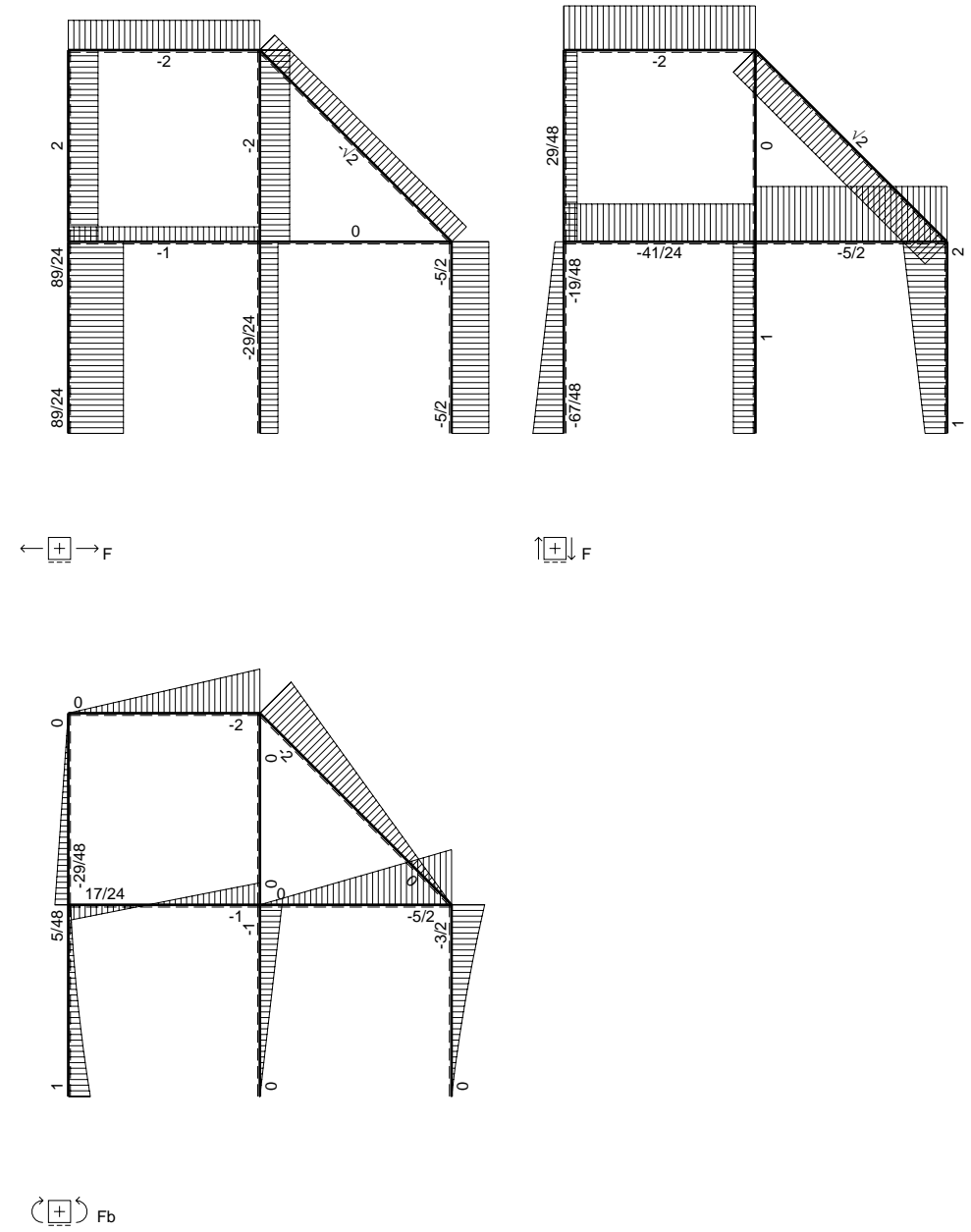
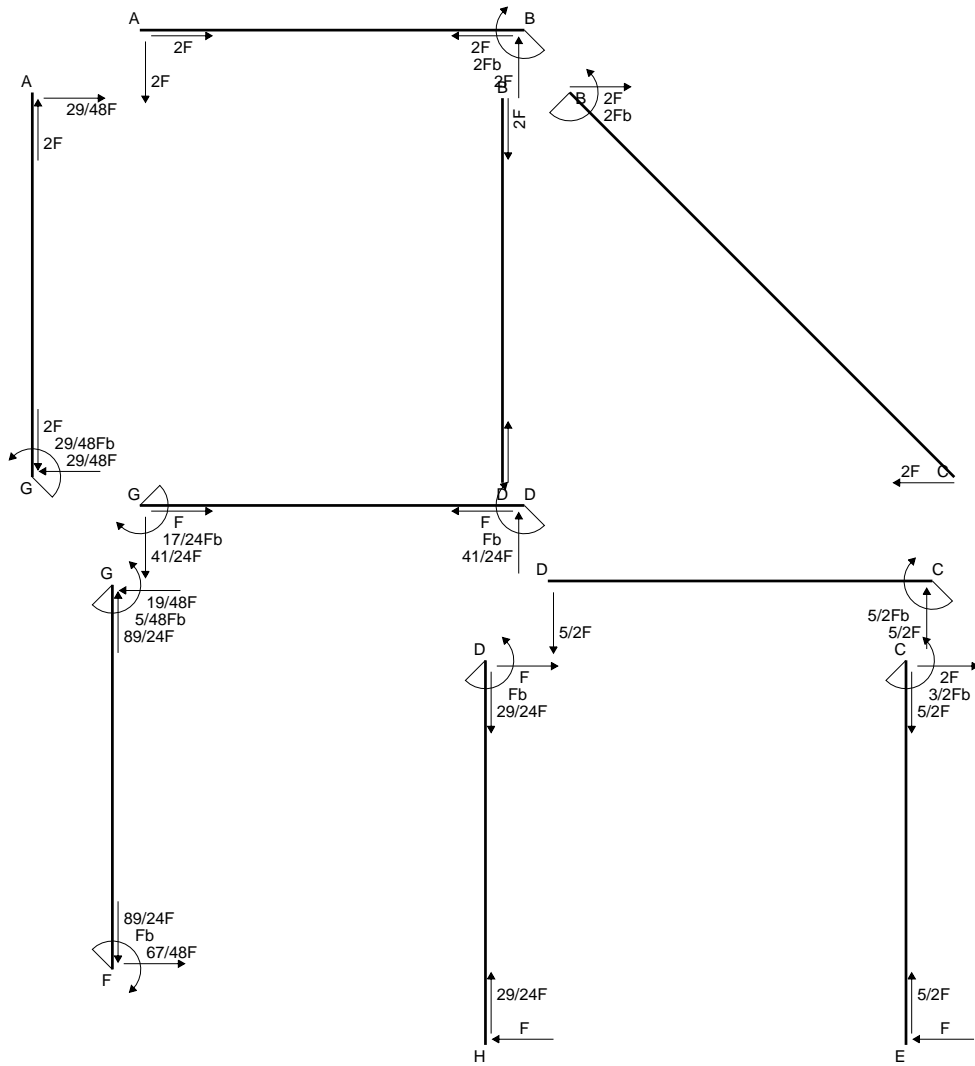

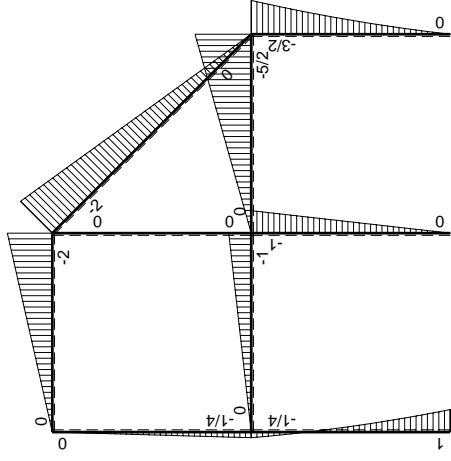
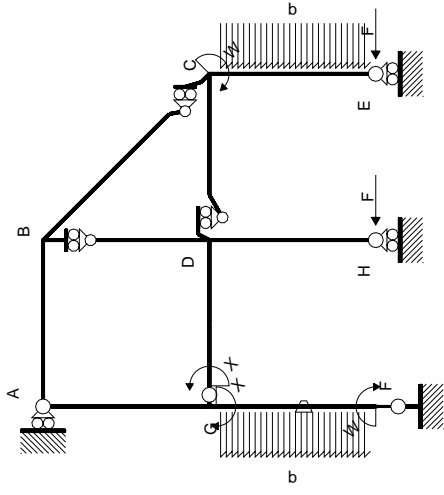

Schema di calcolo iperstatico

M_0 flessione da carichi assegnati

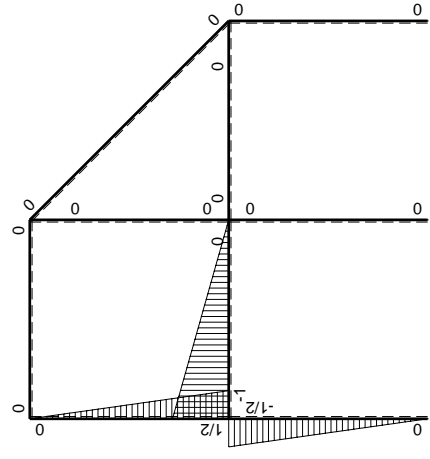

M_x flessione da iperstatica $X=1$

Quadro contributi PLV per iperstatica $X=W_{GD}$

→	$M_x(x)$	$M_o(x)$	θ	$M_x M_o$	$M_x \theta$	$M_x M_x$	$\int M_x(M_o/EJ+\theta)dx$	$\int X M_x M_x/EJ dx$	
AB b	0	-2Fx	0	0	0	0	0+0	0	
BA b	0	2Fb-2Fx	0	0	0	0	0	0	
BC $\sqrt{2}b$	0	-2Fb+ $\sqrt{2}Fx$	0	0	0	0	0	0	
BD b	0	0	0	0	0	0	0+0	0	
DB b	0	0	0	0	0	0	0	0	
DC b	0	-5/2Fx	0	0	0	0	0+0	0	
CD b	0	5/2Fb-5/2Fx	0	0	0	0	0	0	
CE b	0	-3/2Fb+2Fx-1/2qx ²	0	0	0	0	0+0	0	
EC b	0	Fx+1/2qx ²	0	0	0	0	0	0	
FG b	-1/2x/b	Fb-7/4Fx+1/2qx ²	-Fb/EJ	-1/2Fx+7/8Fx ² /b-1/4qx ³ /b	1/2Fx/EJ	1/4x ² /b ²	(-1/48+1/4)Fb ² /EJ	1/12Xb/EJ	
GF b	1/2-1/2x/b	1/4Fb-3/4Fx-1/2qx ²	Fb/EJ	1/8Fb-1/2Fx+1/8Fx ² /b+1/4qx ³ /b	1/2Fb/EJ-1/2Fx/EJ	1/4-1/2x/b+1/4x ² /b ²			
GD b	-1+x/b	-Fx	0	Fx-Fx ² /b	0	1-2x/b+x ² /b ²	(1/6+0)Fb ² /EJ	1/3Xb/EJ	
DG b	x/b	Fb-Fx	0	Fx-Fx ² /b	0	x ² /b ²			
DH b	0	-Fb+Fx	0	0	0	0	0+0	0	
HD b	0	Fx	0	0	0	0	0	0	
GA b	1/2-1/2x/b	-1/4Fb+1/4Fx	0	-1/8Fb+1/4Fx-1/8Fx ² /b	0	1/4-1/2x/b+1/4x ² /b ²	(-1/24+0)Fb ² /EJ	1/12Xb/EJ	
AG b	-1/2x/b	1/4Fx	0	-1/8Fx ² /b	0	1/4x ² /b ²			
	totali							17/48Fb ² /EJ	1/2Xb/EJ
	iperstatica $X=W_{GD}$							-17/24Fb	

Sviluppi di calcolo iperstatica

$$L_{FG}^{xx} = \int_0^b (1/4 x^2/b^2) 1/EJ dx = [1/12 x^3/b^2]_0^b 1/EJ$$

$$= (1/12 b) 1/EJ = 1/12 b/EJ$$

$$L_{GF}^{xx} = \int_0^b (1/4 - 1/2 x/b + 1/4 x^2/b^2) 1/EJ dx = [1/4 x - 1/4 x^2/b + 1/12 x^3/b^2]_0^b 1/EJ$$

$$= (1/4 b - 1/4 b + 1/12 b) 1/EJ = 1/12 b/EJ$$

$$L_{GD}^{xx} = \int_0^b (1 - 2 x/b + x^2/b^2) 1/EJ dx = [x - x^2/b + 1/3 x^3/b^2]_0^b 1/EJ$$

$$= (b - b + 1/3 b) 1/EJ = 1/3 b/EJ$$

$$L_{DG}^{xx} = \int_0^b (x^2/b^2) 1/EJ dx = [1/3 x^3/b^2]_0^b 1/EJ$$

$$= (1/3 b) 1/EJ = 1/3 b/EJ$$

$$L_{GA}^{xx} = \int_0^b (1/4 - 1/2 x/b + 1/4 x^2/b^2) 1/EJ dx = [1/4 x - 1/4 x^2/b + 1/12 x^3/b^2]_0^b 1/EJ$$

$$= (1/4 b - 1/4 b + 1/12 b) 1/EJ = 1/12 b/EJ$$

$$L_{AG}^{xx} = \int_0^b (1/4 x^2/b^2) 1/EJ dx = [1/12 x^3/b^2]_0^b 1/EJ$$

$$= (1/12 b) 1/EJ = 1/12 b/EJ$$

$$L_{FG}^{x\theta} = \int_0^b (-1/2 x/b + 7/8 x^2/b^2 - 1/4 x^3/b^3) Fb 1/EJ dx + \int_0^b (1/2 x/b) \theta dx$$

$$= [-1/4 x^2/b + 7/24 x^3/b^2 - 1/16 x^4/b^3]_0^b Fb 1/EJ + [1/4 x^2/b]_0^b \theta$$

$$= (-1/4 b + 7/24 b - 1/16 b) Fb 1/EJ + (1/4 b) \theta = 11/48 Fb^2/EJ$$

$$L_{GF}^{x\theta} = \int_0^b (1/8 - 1/2 x/b + 1/8 x^2/b^2 + 1/4 x^3/b^3) Fb 1/EJ dx + \int_0^b (-1/2 + 1/2 x/b) \theta dx$$

$$= [1/8 x - 1/4 x^2/b + 1/24 x^3/b^2 + 1/16 x^4/b^3]_0^b Fb 1/EJ + [-1/2 x + 1/4 x^2/b]_0^b \theta$$

$$= (1/8 b - 1/4 b + 1/24 b + 1/16 b) Fb 1/EJ + (-1/2 b + 1/4 b) \theta = 11/48 Fb^2/EJ$$

$$L_{GD}^{x\theta} = \int_0^b (x/b - x^2/b^2) Fb 1/EJ dx = [1/2 x^2/b - 1/3 x^3/b^2]_0^b Fb 1/EJ$$

$$= (1/2 b - 1/3 b) Fb 1/EJ = 1/6 Fb^2/EJ$$

$$L_{DG}^{x\theta} = \int_0^b (x/b - x^2/b^2) Fb 1/EJ dx = [1/2 x^2/b - 1/3 x^3/b^2]_0^b Fb 1/EJ$$

$$= (1/2 b - 1/3 b) Fb 1/EJ = 1/6 Fb^2/EJ$$

$$L_{GA}^{x\theta} = \int_0^b (-1/8 + 1/4 x/b - 1/8 x^2/b^2) Fb 1/EJ dx = [-1/8 x + 1/8 x^2/b - 1/24 x^3/b^2]_0^b Fb 1/EJ$$

$$= (-1/8 b + 1/8 b - 1/24 b) Fb 1/EJ = -1/24 Fb^2/EJ$$

$$L_{AG}^{x\theta} = \int_0^b (-1/8 x^2/b^2) Fb 1/EJ dx = [-1/24 x^3/b^2]_0^b Fb 1/EJ$$

$$= (-1/24 b) Fb 1/EJ = -1/24 Fb^2/EJ$$

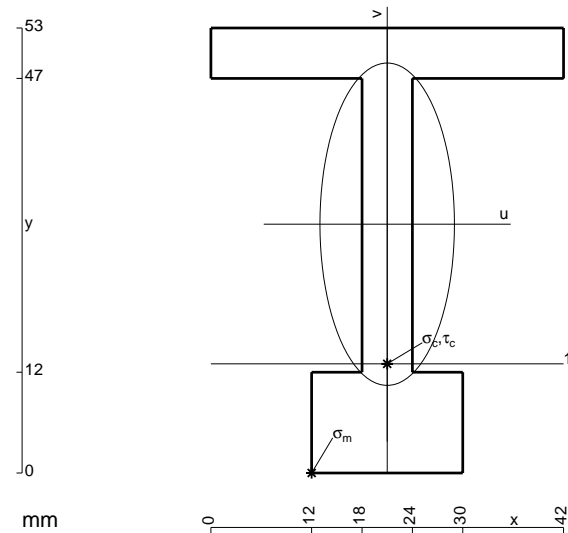

$$A = 678. \text{ mm}^2$$

$$J_u = 249963. \text{ mm}^4$$

$$J_v = 43506. \text{ mm}^4$$

$$y_g = 29.63 \text{ mm}$$

$$T_y = -2125. \text{ N}$$

$$M_x = -2018750. \text{ Nmm}$$

$$x_m = 12. \text{ mm}$$

$$u_m = -9. \text{ mm}$$

$$v_m = -29.63 \text{ mm}$$

$$\sigma_m = -Mv/J_u = -239.3 \text{ N/mm}^2$$

$$x_c = 21. \text{ mm}$$

$$y_c = 13. \text{ mm}$$

$$v_c = -16.63 \text{ mm}$$

$$\sigma_c = -Mv/J_u = -134.3 \text{ N/mm}^2$$

$$\tau_c = 7.378 \text{ N/mm}^2$$

$$\sigma_q = \sqrt{\sigma^2 + 3\tau^2} = 134.9 \text{ N/mm}^2$$

$$S = 5207. \text{ mm}^3$$

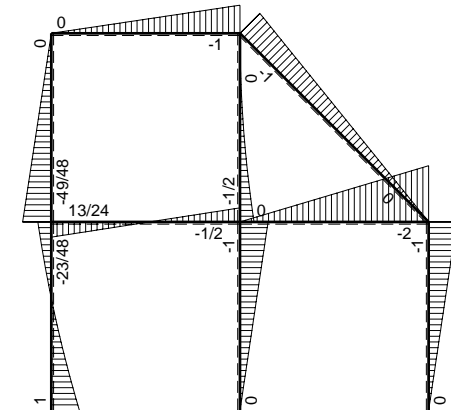
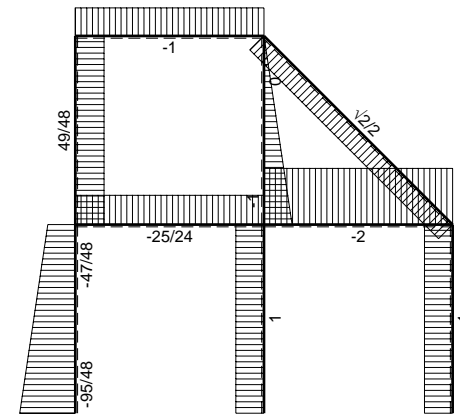
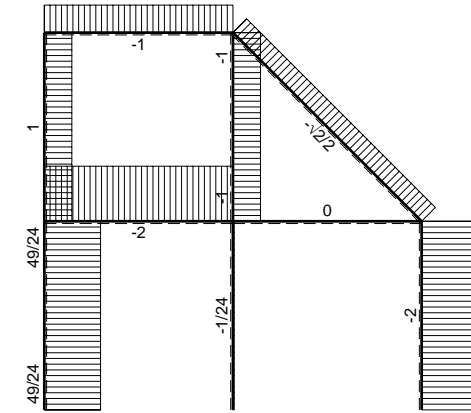
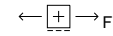
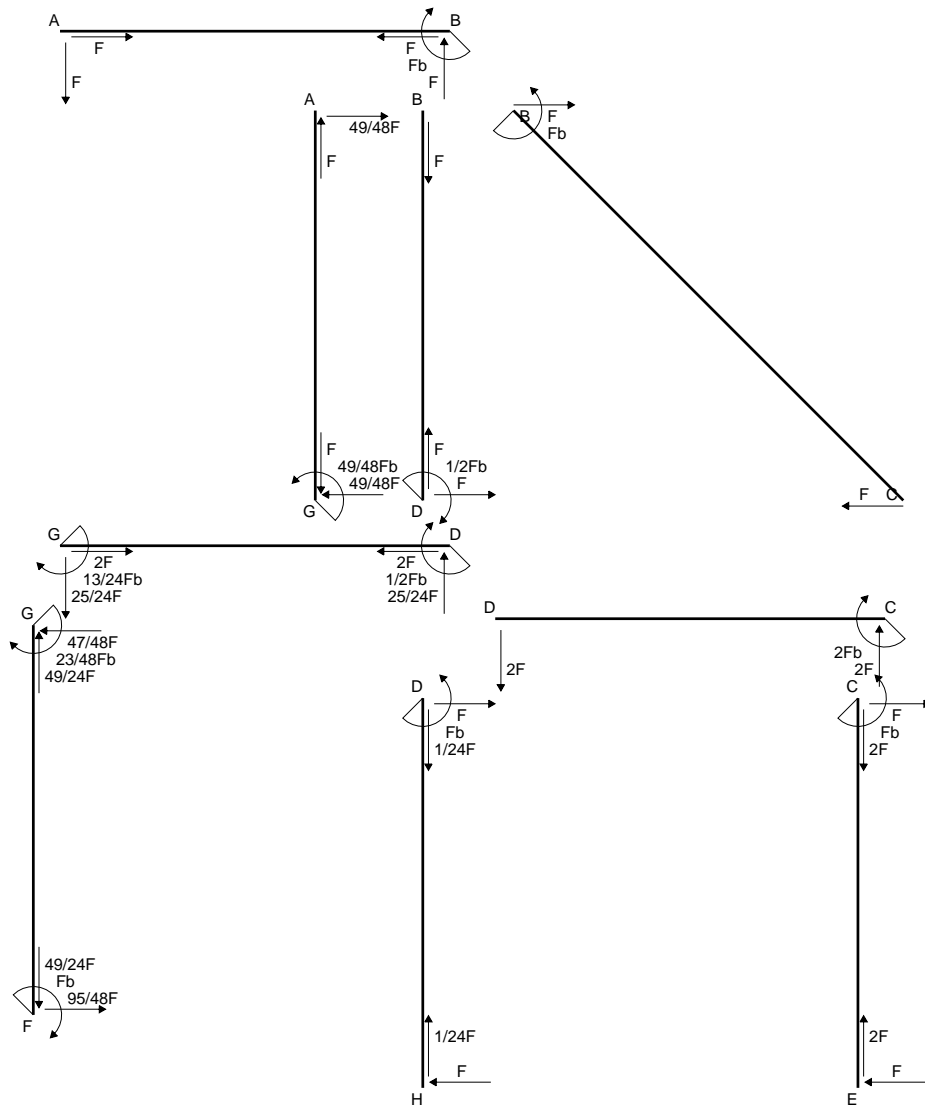

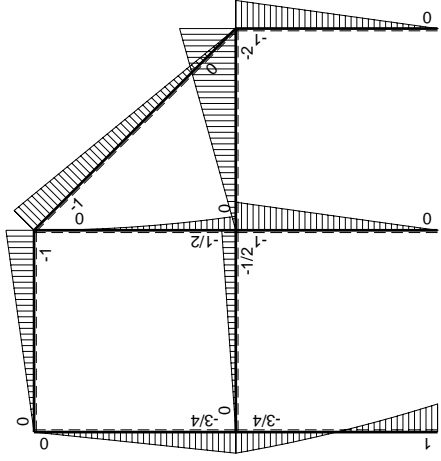
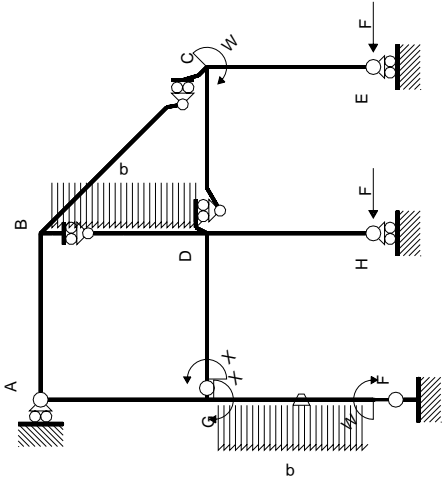

Schema di calcolo iperstatico

M_0 flessione da carichi assegnati

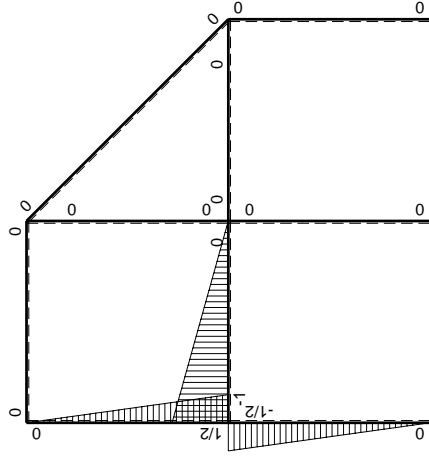

M_x flessione da iperstatica $X=1$

Quadro contributi PLV per iperstatica $X=W_{GD}$

→	$M_x(x)$	$M_o(x)$	θ	$M_x M_o$	$M_x \theta$	$M_x M_x$	$\int M_x(M_o/EJ+\theta)dx$	$\int X M_x M_x/EJdx$
AB b	0	-Fx	0	0	0	0	0+0	0
BA b	0	Fb-Fx	0	0	0	0	0	0
BC $\sqrt{2}b$	0	-Fb+ $\sqrt{2}/2Fx$	0	0	0	0	0	0
BD b	0	-1/2qx ²	0	0	0	0	0+0	0
DB b	0	1/2Fb-Fx+1/2qx ²	0	0	0	0	0	0
DC b	0	-2Fx	0	0	0	0	0+0	0
CD b	0	2Fb-2Fx	0	0	0	0	0	0
CE b	0	-Fb+Fx	0	0	0	0	0+0	0
EC b	0	Fx	0	0	0	0	0	0
FG b	-1/2x/b	Fb-9/4Fx+1/2qx ²	-Fb/EJ	-1/2Fx+9/8Fx ² /b-1/4qx ³ /b	1/2Fx/EJ	1/4x ² /b ²	(1/16+1/4)Fb ² /EJ	1/12Xb/EJ
GF b	1/2-1/2x/b	3/4Fb-5/4Fx-1/2qx ²	Fb/EJ	3/8Fb-Fx+3/8Fx ² /b+1/4qx ³ /b	1/2Fb/EJ-1/2Fx/EJ	1/4-1/2x/b+1/4x ² /b ²		
GD b	-1+x/b	-1/2Fx	0	1/2Fx-1/2Fx ² /b	0	1-2x/b+x ² /b ²	(1/12+0)Fb ² /EJ	1/3Xb/EJ
DG b	x/b	1/2Fb-1/2Fx	0	1/2Fx-1/2Fx ² /b	0	x ² /b ²		
DH b	0	-Fb+Fx	0	0	0	0	0+0	0
HD b	0	Fx	0	0	0	0	0	0
GA b	1/2-1/2x/b	-3/4Fb+3/4Fx	0	-3/8Fb+3/4Fx-3/8Fx ² /b	0	1/4-1/2x/b+1/4x ² /b ²	(-1/8+0)Fb ² /EJ	1/12Xb/EJ
AG b	-1/2x/b	3/4Fx	0	-3/8Fx ² /b	0	1/4x ² /b ²		
	totali						13/48Fb ² /EJ	1/2Xb/EJ
	iperstatica $X=W_{GD}$						-13/24Fb	

Sviluppi di calcolo iperstatica

$$L_{FG}^{xx} = \int_0^b (1/4 x^2/b^2) 1/EJ dx = [1/12 x^3/b^2]_0^b 1/EJ$$

$$= (1/12 b) 1/EJ = 1/12 b/EJ$$

$$L_{GF}^{xx} = \int_0^b (1/4 - 1/2 x/b + 1/4 x^2/b^2) 1/EJ dx = [1/4 x - 1/4 x^2/b + 1/12 x^3/b^2]_0^b 1/EJ$$

$$= (1/4 b - 1/4 b + 1/12 b) 1/EJ = 1/12 b/EJ$$

$$L_{GD}^{xx} = \int_0^b (1 - 2 x/b + x^2/b^2) 1/EJ dx = [x - x^2/b + 1/3 x^3/b^2]_0^b 1/EJ$$

$$= (b - b + 1/3 b) 1/EJ = 1/3 b/EJ$$

$$L_{DG}^{xx} = \int_0^b (x^2/b^2) 1/EJ dx = [1/3 x^3/b^2]_0^b 1/EJ$$

$$= (1/3 b) 1/EJ = 1/3 b/EJ$$

$$L_{GA}^{xx} = \int_0^b (1/4 - 1/2 x/b + 1/4 x^2/b^2) 1/EJ dx = [1/4 x - 1/4 x^2/b + 1/12 x^3/b^2]_0^b 1/EJ$$

$$= (1/4 b - 1/4 b + 1/12 b) 1/EJ = 1/12 b/EJ$$

$$L_{AG}^{xx} = \int_0^b (1/4 x^2/b^2) 1/EJ dx = [1/12 x^3/b^2]_0^b 1/EJ$$

$$= (1/12 b) 1/EJ = 1/12 b/EJ$$

$$L_{FG}^{xo} = \int_0^b (-1/2 x/b + 9/8 x^2/b^2 - 1/4 x^3/b^3) Fb 1/EJ dx + \int_0^b (1/2 x/b) \theta dx$$

$$= [-1/4 x^2/b + 3/8 x^3/b^2 - 1/16 x^4/b^3]_0^b Fb 1/EJ + [1/4 x^2/b]_0^b \theta$$

$$= (-1/4 b + 3/8 b - 1/16 b) Fb 1/EJ + (1/4 b) \theta = 5/16 Fb^2/EJ$$

$$L_{GF}^{xo} = \int_0^b (3/8 - x/b + 3/8 x^2/b^2 + 1/4 x^3/b^3) Fb 1/EJ dx + \int_0^b (-1/2 + 1/2 x/b) \theta dx$$

$$= [3/8 x - 1/2 x^2/b + 1/8 x^3/b^2 + 1/16 x^4/b^3]_0^b Fb 1/EJ + [-1/2 x + 1/4 x^2/b]_0^b \theta$$

$$= (3/8 b - 1/2 b + 1/8 b + 1/16 b) Fb 1/EJ + (-1/2 b + 1/4 b) \theta = 5/16 Fb^2/EJ$$

$$L_{GD}^{xo} = \int_0^b (1/2 x/b - 1/2 x^2/b^2) Fb 1/EJ dx = [1/4 x^2/b - 1/6 x^3/b^2]_0^b Fb 1/EJ$$

$$= (1/4 b - 1/6 b) Fb 1/EJ = 1/12 Fb^2/EJ$$

$$L_{DG}^{xo} = \int_0^b (1/2 x/b - 1/2 x^2/b^2) Fb 1/EJ dx = [1/4 x^2/b - 1/6 x^3/b^2]_0^b Fb 1/EJ$$

$$= (1/4 b - 1/6 b) Fb 1/EJ = 1/12 Fb^2/EJ$$

$$L_{GA}^{xo} = \int_0^b (-3/8 + 3/4 x/b - 3/8 x^2/b^2) Fb 1/EJ dx = [-3/8 x + 3/8 x^2/b - 1/8 x^3/b^2]_0^b Fb 1/EJ$$

$$= (-3/8 b + 3/8 b - 1/8 b) Fb 1/EJ = -1/8 Fb^2/EJ$$

$$L_{AG}^{xo} = \int_0^b (-3/8 x^2/b^2) Fb 1/EJ dx = [-1/8 x^3/b^2]_0^b Fb 1/EJ$$

$$= (-1/8 b) Fb 1/EJ = -1/8 Fb^2/EJ$$

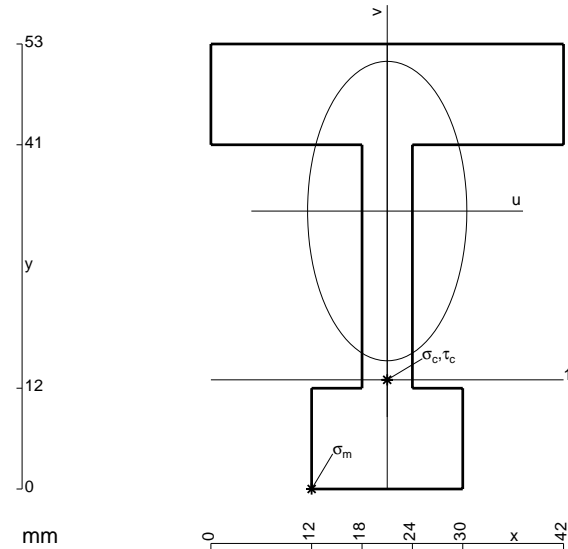

- A = 894. mm²
- J_u = 284424. mm⁴
- J_v = 80442. mm⁴
- y_g = 33.1 mm
- T_y = -3420. N
- M_x = -1710000. Nmm
- x_m = 12. mm
- u_m = -9. mm
- v_m = -33.1 mm
- σ_m = -Mv/J_u = -199. N/mm²
- x_c = 21. mm
- y_c = 13. mm
- v_c = -20.1 mm
- σ_c = -Mv/J_u = -120.9 N/mm²
- τ_c = 11.98 N/mm²
- σ_q = √σ²+3τ² = 122.6 N/mm²
- S = 5978. mm³

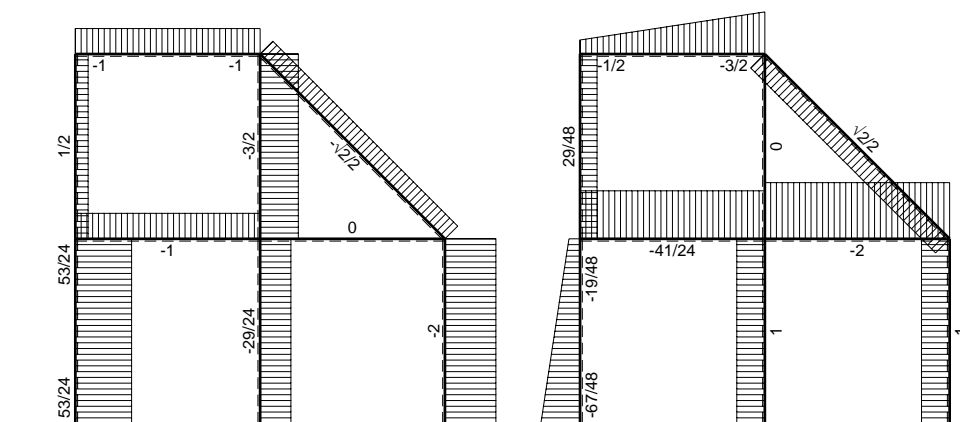
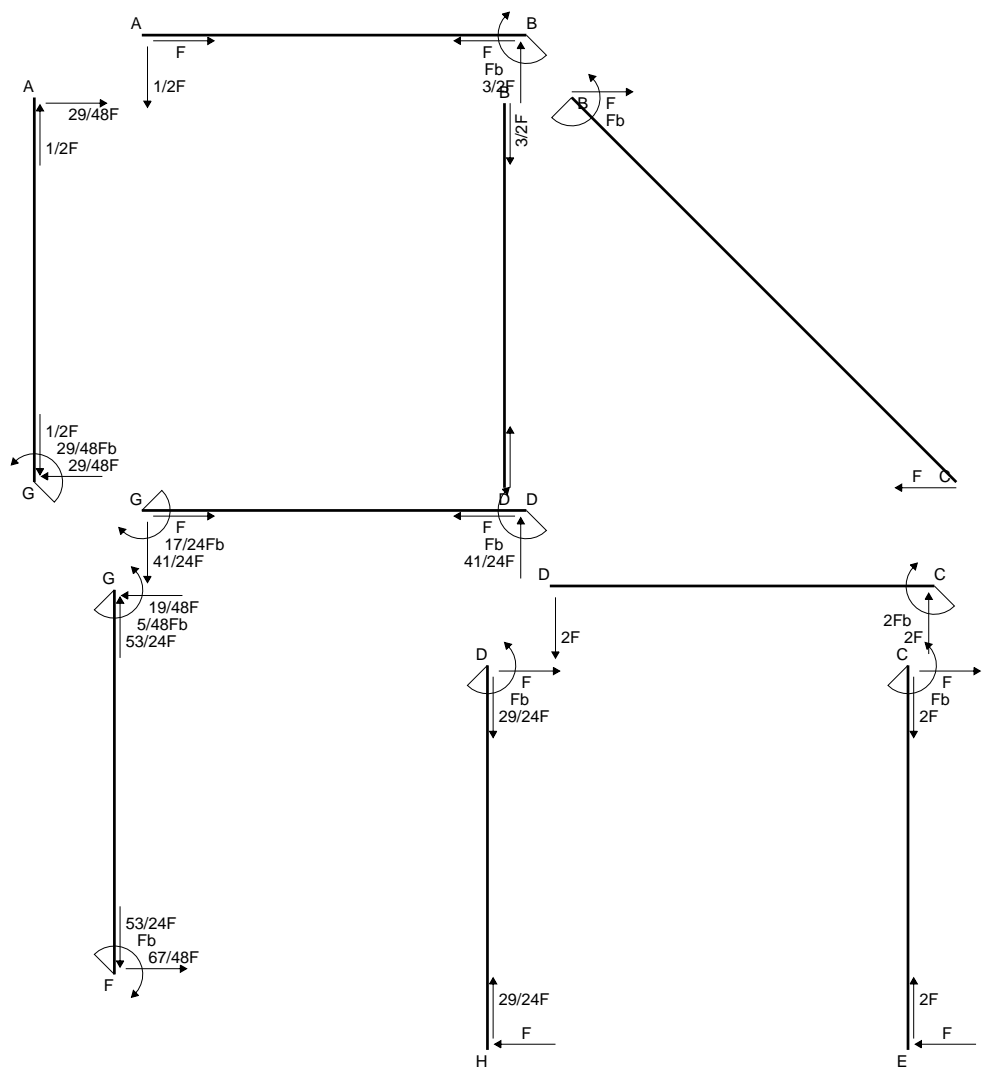

← ⊕ → F

↑ ⊕ ↓ F

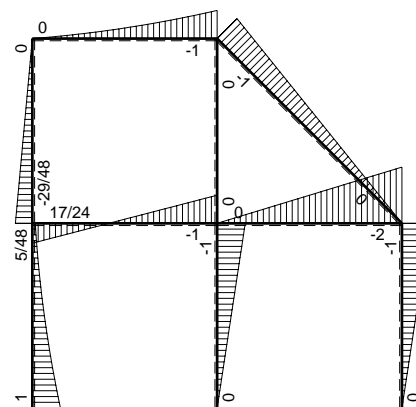

⊕ ⊖ F_b

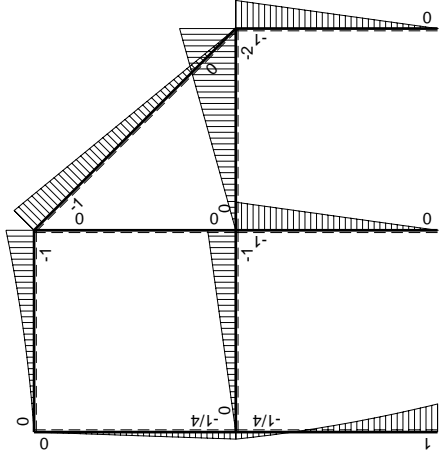
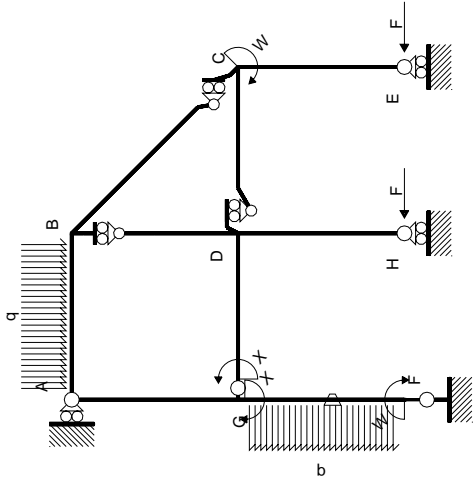

Schema di calcolo iperstatico

M_0 flessione da carichi assegnati



M_x flessione da iperstatica $X=1$

Quadro contributi PLV per iperstatica $X=W_{GD}$

→	$M_x(x)$	$M_o(x)$	θ	$M_x M_o$	$M_x \theta$	$M_x M_x$	$\int M_x(M_o/EJ+\theta)dx$	$\int X M_x M_x/EJ dx$
AB b	0	$-1/2Fx-1/2qx^2$	0	0	0	0	0+0	0
BA b	0	$Fb-3/2Fx+1/2qx^2$	0	0	0	0	0	0
BC $\sqrt{2}b$	0	$-Fb+\sqrt{2}/2Fx$	0	0	0	0	0	0
BD b	0	0	0	0	0	0	0+0	0
DB b	0	0	0	0	0	0	0	0
DC b	0	$-2Fx$	0	0	0	0	0+0	0
CD b	0	$2Fb-2Fx$	0	0	0	0	0	0
CE b	0	$-Fb+Fx$	0	0	0	0	0+0	0
EC b	0	Fx	0	0	0	0	0	0
FG b	$-1/2x/b$	$Fb-7/4Fx+1/2qx^2$	$-Fb/EJ$	$-1/2Fx+7/8Fx^2/b-1/4qx^3/b$	$1/2Fx/EJ$	$1/4x^2/b^2$	$(-1/48+1/4)Fb^2/EJ$	$1/12Xb/EJ$
GF b	$1/2-1/2x/b$	$1/4Fb-3/4Fx-1/2qx^2$	Fb/EJ	$1/8Fb-1/2Fx+1/8Fx^2/b+1/4qx^3/b$	$1/2Fb/EJ-1/2Fx/EJ$	$1/4-1/2x/b+1/4x^2/b^2$		
GD b	$-1+x/b$	$-Fx$	0	$Fx-Fx^2/b$	0	$1-2x/b+x^2/b^2$	$(1/6+0)Fb^2/EJ$	$1/3Xb/EJ$
DG b	x/b	$Fb-Fx$	0	$Fx-Fx^2/b$	0	x^2/b^2		
DH b	0	$-Fb+Fx$	0	0	0	0	0+0	0
HD b	0	Fx	0	0	0	0	0	0
GA b	$1/2-1/2x/b$	$-1/4Fb+1/4Fx$	0	$-1/8Fb+1/4Fx-1/8Fx^2/b$	0	$1/4-1/2x/b+1/4x^2/b^2$	$(-1/24+0)Fb^2/EJ$	$1/12Xb/EJ$
AG b	$-1/2x/b$	$1/4Fx$	0	$-1/8Fx^2/b$	0	$1/4x^2/b^2$		
	totali						$17/48Fb^2/EJ$	$1/2Xb/EJ$
	iperstatica $X=W_{GD}$						$-17/24Fb$	

Sviluppi di calcolo iperstatica

$$L_{FG}^{xx} = \int_0^b (1/4 x^2/b^2) 1/EJ dx = [1/12 x^3/b^2]_0^b 1/EJ$$

$$= (1/12 b) 1/EJ = 1/12 b/EJ$$

$$L_{GF}^{xx} = \int_0^b (1/4 - 1/2 x/b + 1/4 x^2/b^2) 1/EJ dx = [1/4 x - 1/4 x^2/b + 1/12 x^3/b^2]_0^b 1/EJ$$

$$= (1/4 b - 1/4 b + 1/12 b) 1/EJ = 1/12 b/EJ$$

$$L_{GD}^{xx} = \int_0^b (1 - 2 x/b + x^2/b^2) 1/EJ dx = [x - x^2/b + 1/3 x^3/b^2]_0^b 1/EJ$$

$$= (b - b + 1/3 b) 1/EJ = 1/3 b/EJ$$

$$L_{DG}^{xx} = \int_0^b (x^2/b^2) 1/EJ dx = [1/3 x^3/b^2]_0^b 1/EJ$$

$$= (1/3 b) 1/EJ = 1/3 b/EJ$$

$$L_{GA}^{xx} = \int_0^b (1/4 - 1/2 x/b + 1/4 x^2/b^2) 1/EJ dx = [1/4 x - 1/4 x^2/b + 1/12 x^3/b^2]_0^b 1/EJ$$

$$= (1/4 b - 1/4 b + 1/12 b) 1/EJ = 1/12 b/EJ$$

$$L_{AG}^{xx} = \int_0^b (1/4 x^2/b^2) 1/EJ dx = [1/12 x^3/b^2]_0^b 1/EJ$$

$$= (1/12 b) 1/EJ = 1/12 b/EJ$$

$$L_{FG}^{xo} = \int_0^b (-1/2 x/b + 7/8 x^2/b^2 - 1/4 x^3/b^3) Fb 1/EJ dx + \int_0^b (1/2 x/b) \theta dx$$

$$= [-1/4 x^2/b + 7/24 x^3/b^2 - 1/16 x^4/b^3]_0^b Fb 1/EJ + [1/4 x^2/b]_0^b \theta$$

$$= (-1/4 b + 7/24 b - 1/16 b) Fb 1/EJ + (1/4 b) \theta = 11/48 Fb^2/EJ$$

$$L_{GF}^{xo} = \int_0^b (1/8 - 1/2 x/b + 1/8 x^2/b^2 + 1/4 x^3/b^3) Fb 1/EJ dx + \int_0^b (-1/2 + 1/2 x/b) \theta dx$$

$$= [1/8 x - 1/4 x^2/b + 1/24 x^3/b^2 + 1/16 x^4/b^3]_0^b Fb 1/EJ + [-1/2 x + 1/4 x^2/b]_0^b \theta$$

$$= (1/8 b - 1/4 b + 1/24 b + 1/16 b) Fb 1/EJ + (-1/2 b + 1/4 b) \theta = 11/48 Fb^2/EJ$$

$$L_{GD}^{xo} = \int_0^b (x/b - x^2/b^2) Fb 1/EJ dx = [1/2 x^2/b - 1/3 x^3/b^2]_0^b Fb 1/EJ$$

$$= (1/2 b - 1/3 b) Fb 1/EJ = 1/6 Fb^2/EJ$$

$$L_{DG}^{xo} = \int_0^b (x/b - x^2/b^2) Fb 1/EJ dx = [1/2 x^2/b - 1/3 x^3/b^2]_0^b Fb 1/EJ$$

$$= (1/2 b - 1/3 b) Fb 1/EJ = 1/6 Fb^2/EJ$$

$$L_{GA}^{xo} = \int_0^b (-1/8 + 1/4 x/b - 1/8 x^2/b^2) Fb 1/EJ dx = [-1/8 x + 1/8 x^2/b - 1/24 x^3/b^2]_0^b Fb 1/EJ$$

$$= (-1/8 b + 1/8 b - 1/24 b) Fb 1/EJ = -1/24 Fb^2/EJ$$

$$L_{AG}^{xo} = \int_0^b (-1/8 x^2/b^2) Fb 1/EJ dx = [-1/24 x^3/b^2]_0^b Fb 1/EJ$$

$$= (-1/24 b) Fb 1/EJ = -1/24 Fb^2/EJ$$

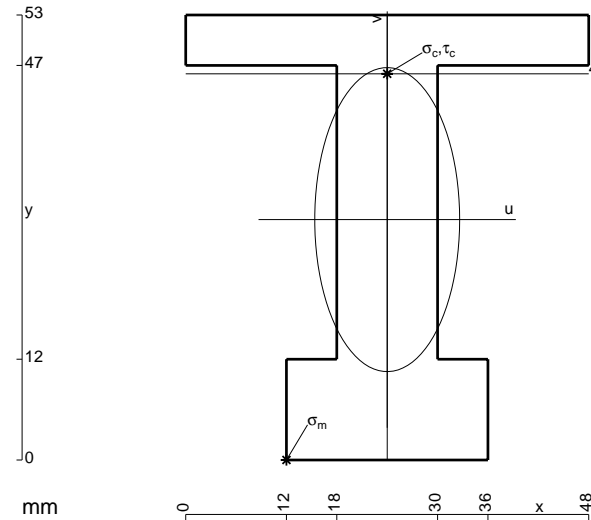

- A = 996. mm²
- J_u = 326526. mm⁴
- J_v = 74160. mm⁴
- y_g = 28.63 mm
- T_y = -4340. N
- M_x = -2387000. Nmm
- x_m = 12. mm
- u_m = -12. mm
- v_m = -28.63 mm
- σ_m = -Mv/J_u = -209.3 N/mm²
- x_c = 24. mm
- y_c = 46. mm
- v_c = 17.37 mm
- σ_c = -Mv/J_u = 127. N/mm²
- τ_c = 7.054 N/mm²
- σ_q = √σ²+3τ² = 127.5 N/mm²
- S = 6368. mm³

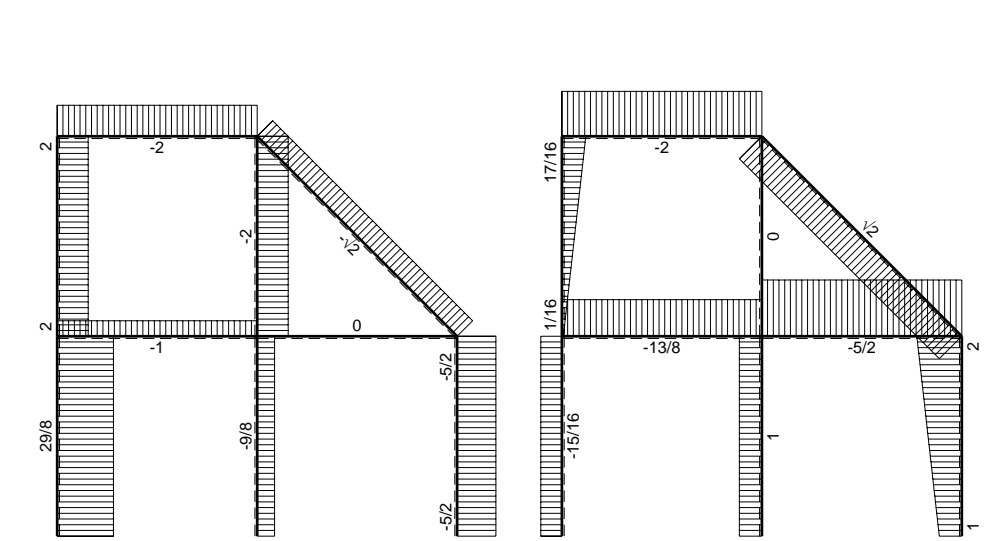
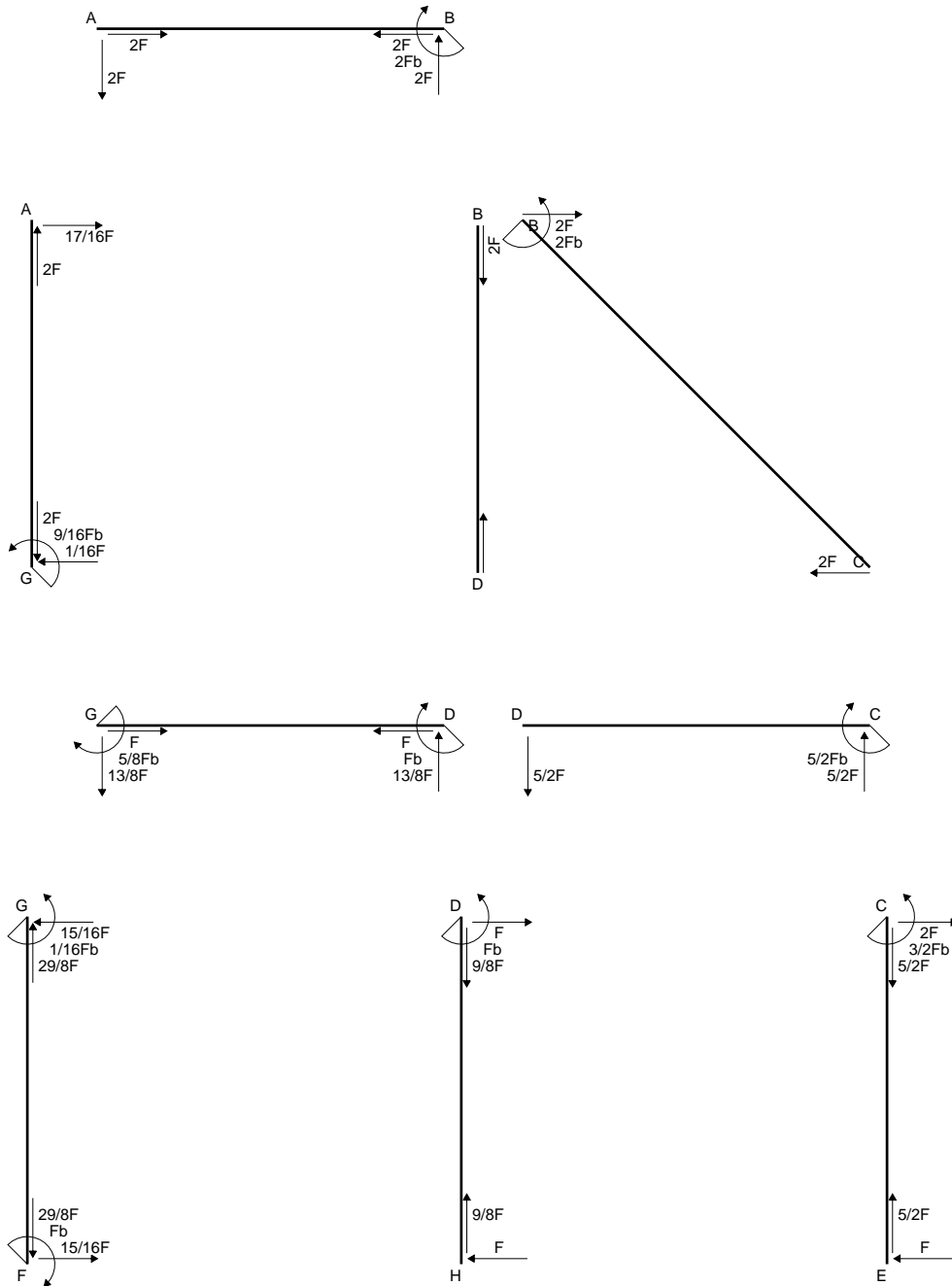

← ⊕ → F

↑ ⊕ ↓ F

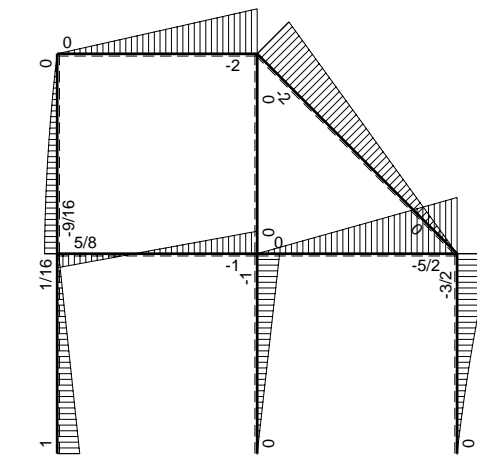

⊕ ⊖ F_b

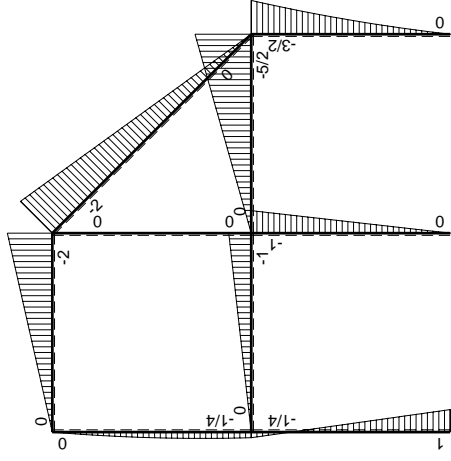
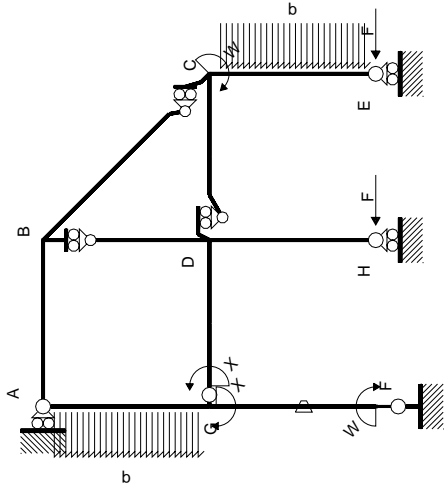

Schema di calcolo iperstatico

M₀ flessione da carichi assegnati

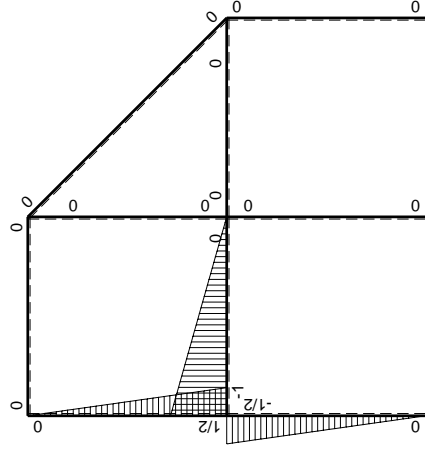

M_x flessione da iperstatica X=1

Quadro contributi PLV per iperstatica $X=W_{GD}$

→	$M_x(x)$	$M_o(x)$	θ	$M_x M_o$	$M_x \theta$	$M_x M_x$	$\int M_x(M_o/EJ+\theta)dx$	$\int X M_x M_x/EJ dx$	
AB b	0	-2Fx	0	0	0	0	0+0	0	
BA b	0	2Fb-2Fx	0	0	0	0	0	0	
BC $\sqrt{2}b$	0	-2Fb+ $\sqrt{2}Fx$	0	0	0	0	0	0	
BD b	0	0	0	0	0	0	0+0	0	
DB b	0	0	0	0	0	0	0	0	
DC b	0	-5/2Fx	0	0	0	0	0+0	0	
CD b	0	5/2Fb-5/2Fx	0	0	0	0	0	0	
CE b	0	-3/2Fb+2Fx-1/2qx ²	0	0	0	0	0+0	0	
EC b	0	Fx+1/2qx ²	0	0	0	0	0	0	
FG b	-1/2x/b	Fb-5/4Fx	-Fb/EJ	-1/2Fx+5/8Fx ² /b	1/2Fx/EJ	1/4x ² /b ²	(-1/24+1/4)Fb ² /EJ	1/12Xb/EJ	
GF b	1/2-1/2x/b	1/4Fb-5/4Fx	Fb/EJ	1/8Fb-3/4Fx+5/8Fx ² /b	1/2Fb/EJ-1/2Fx/EJ	1/4-1/2x/b+1/4x ² /b ²			
GD b	-1+x/b	-Fx	0	Fx-Fx ² /b	0	1-2x/b+x ² /b ²	(1/6+0)Fb ² /EJ	1/3Xb/EJ	
DG b	x/b	Fb-Fx	0	Fx-Fx ² /b	0	x ² /b ²			
DH b	0	-Fb+Fx	0	0	0	0	0+0	0	
HD b	0	Fx	0	0	0	0	0	0	
GA b	1/2-1/2x/b	-1/4Fb-1/4Fx+1/2qx ²	0	-1/8Fb+3/8Fx ² /b-1/4qx ³ /b	0	1/4-1/2x/b+1/4x ² /b ²	(-1/16+0)Fb ² /EJ	1/12Xb/EJ	
AG b	-1/2x/b	3/4Fx-1/2qx ²	0	-3/8Fx ² /b+1/4qx ³ /b	0	1/4x ² /b ²			
	totali							5/16Fb ² /EJ	1/2Xb/EJ
	iperstatica $X=W_{GD}$							-5/8Fb	

Sviluppi di calcolo iperstatica

$$L_{FG}^{xx} = \int_0^b (1/4 x^2/b^2) 1/EJ dx = [1/12 x^3/b^2]_0^b 1/EJ$$

$$= (1/12 b) 1/EJ = 1/12 b/EJ$$

$$L_{GF}^{xx} = \int_0^b (1/4 - 1/2 x/b + 1/4 x^2/b^2) 1/EJ dx = [1/4 x - 1/4 x^2/b + 1/12 x^3/b^2]_0^b 1/EJ$$

$$= (1/4 b - 1/4 b + 1/12 b) 1/EJ = 1/12 b/EJ$$

$$L_{GD}^{xx} = \int_0^b (1 - 2 x/b + x^2/b^2) 1/EJ dx = [x - x^2/b + 1/3 x^3/b^2]_0^b 1/EJ$$

$$= (b - b + 1/3 b) 1/EJ = 1/3 b/EJ$$

$$L_{DG}^{xx} = \int_0^b (x^2/b^2) 1/EJ dx = [1/3 x^3/b^2]_0^b 1/EJ$$

$$= (1/3 b) 1/EJ = 1/3 b/EJ$$

$$L_{GA}^{xx} = \int_0^b (1/4 - 1/2 x/b + 1/4 x^2/b^2) 1/EJ dx = [1/4 x - 1/4 x^2/b + 1/12 x^3/b^2]_0^b 1/EJ$$

$$= (1/4 b - 1/4 b + 1/12 b) 1/EJ = 1/12 b/EJ$$

$$L_{AG}^{xx} = \int_0^b (1/4 x^2/b^2) 1/EJ dx = [1/12 x^3/b^2]_0^b 1/EJ$$

$$= (1/12 b) 1/EJ = 1/12 b/EJ$$

$$L_{FG}^{xo} = \int_0^b (-1/2 x/b + 5/8 x^2/b^2) Fb 1/EJ dx + \int_0^b (1/2 x/b) \theta dx$$

$$= [-1/4 x^2/b + 5/24 x^3/b^2]_0^b Fb 1/EJ + [1/4 x^2/b]_0^b \theta$$

$$= (-1/4 b + 5/24 b) Fb 1/EJ + (1/4 b) \theta = 5/24 Fb^2/EJ$$

$$L_{GF}^{xo} = \int_0^b (1/8 - 3/4 x/b + 5/8 x^2/b^2) Fb 1/EJ dx + \int_0^b (-1/2 + 1/2 x/b) \theta dx$$

$$= [1/8 x - 3/8 x^2/b + 5/24 x^3/b^2]_0^b Fb 1/EJ + [-1/2 x + 1/4 x^2/b]_0^b \theta$$

$$= (1/8 b - 3/8 b + 5/24 b) Fb 1/EJ + (-1/2 b + 1/4 b) \theta = 5/24 Fb^2/EJ$$

$$L_{GD}^{xo} = \int_0^b (x/b - x^2/b^2) Fb 1/EJ dx = [1/2 x^2/b - 1/3 x^3/b^2]_0^b Fb 1/EJ$$

$$= (1/2 b - 1/3 b) Fb 1/EJ = 1/6 Fb^2/EJ$$

$$L_{DG}^{xo} = \int_0^b (x/b - x^2/b^2) Fb 1/EJ dx = [1/2 x^2/b - 1/3 x^3/b^2]_0^b Fb 1/EJ$$

$$= (1/2 b - 1/3 b) Fb 1/EJ = 1/6 Fb^2/EJ$$

$$L_{GA}^{xo} = \int_0^b (-1/8 + 3/8 x^2/b^2 - 1/4 x^3/b^3) Fb 1/EJ dx = [-1/8 x + 1/8 x^3/b^2 - 1/16 x^4/b^3]_0^b Fb 1/EJ$$

$$= (-1/8 b + 1/8 b - 1/16 b) Fb 1/EJ = -1/16 Fb^2/EJ$$

$$L_{AG}^{xo} = \int_0^b (-3/8 x^2/b^2 + 1/4 x^3/b^3) Fb 1/EJ dx = [-1/8 x^3/b^2 + 1/16 x^4/b^3]_0^b Fb 1/EJ$$

$$= (-1/8 b + 1/16 b) Fb 1/EJ = -1/16 Fb^2/EJ$$

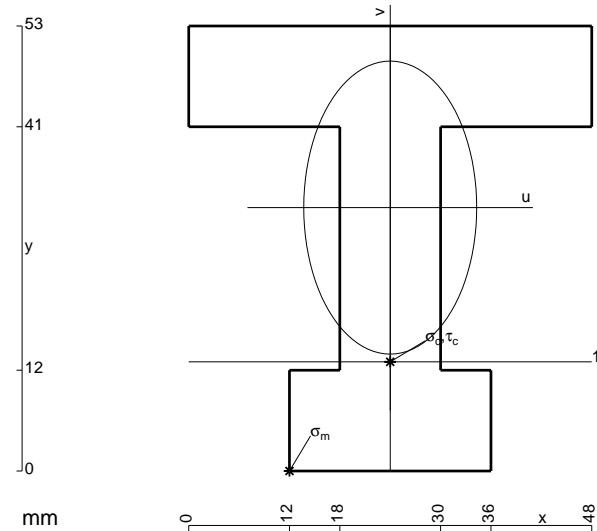

- A = 1212. mm²
- J_u = 369093. mm⁴
- J_v = 128592. mm⁴
- y_g = 31.37 mm
- T_y = -4300. N
- M_x = -2580000. Nmm
- x_m = 12. mm
- u_m = -12. mm
- v_m = -31.37 mm
- σ_m = -Mv/J_u = -219.3 N/mm²
- x_c = 24. mm
- y_c = 13. mm
- v_c = -18.37 mm
- σ_c = -Mv/J_u = -128.4 N/mm²
- τ_c = 7.314 N/mm²
- σ_o = √σ²+3τ² = 129. N/mm²
- S = 7533. mm³

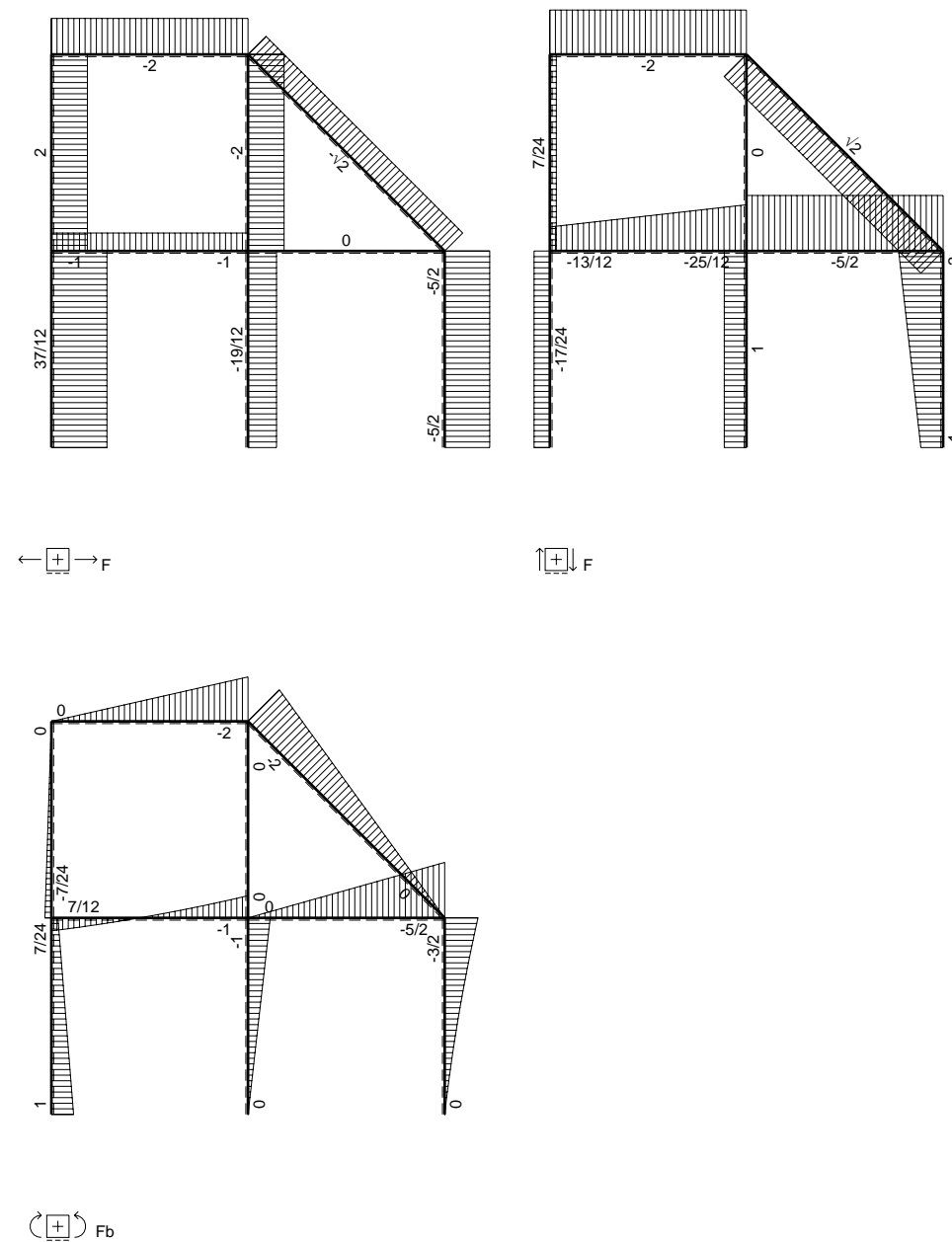
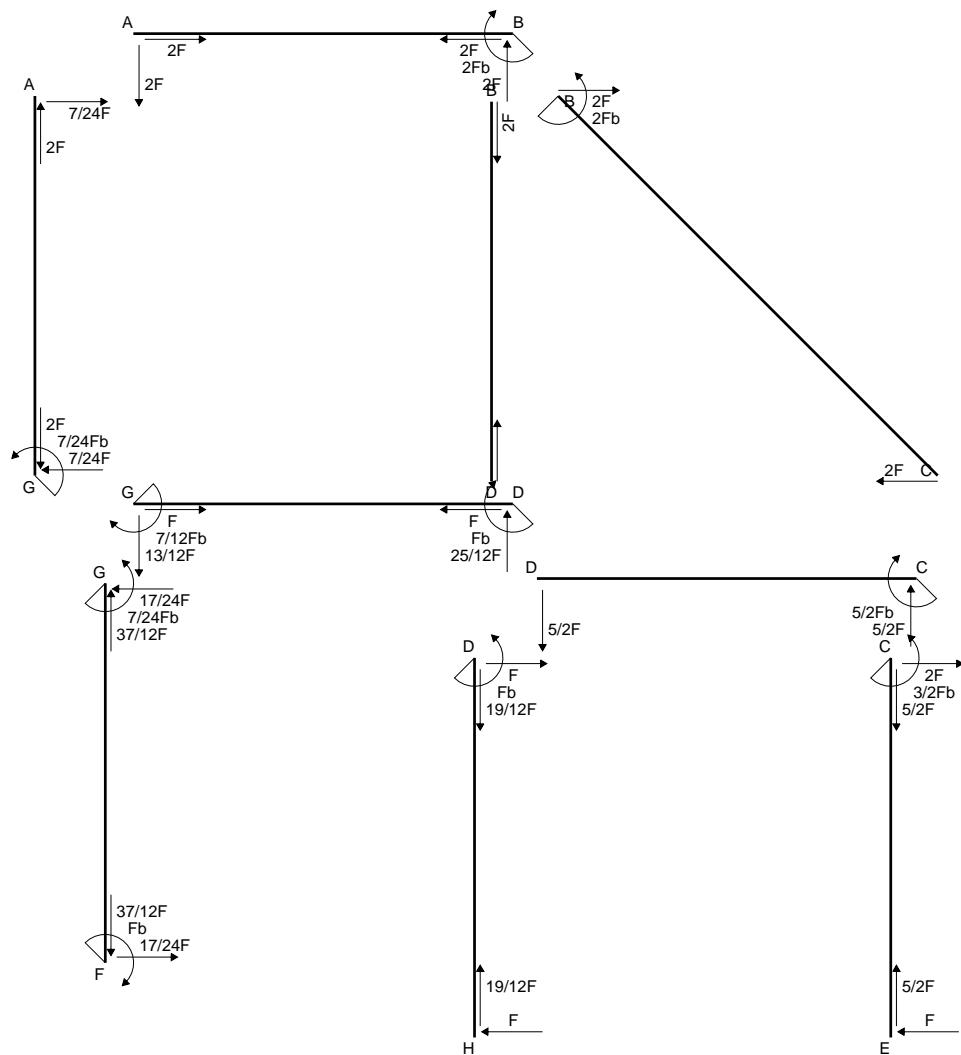

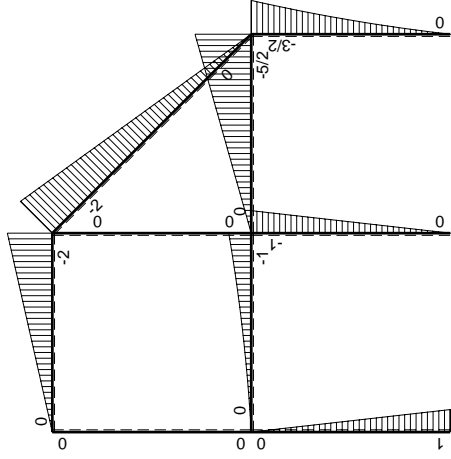
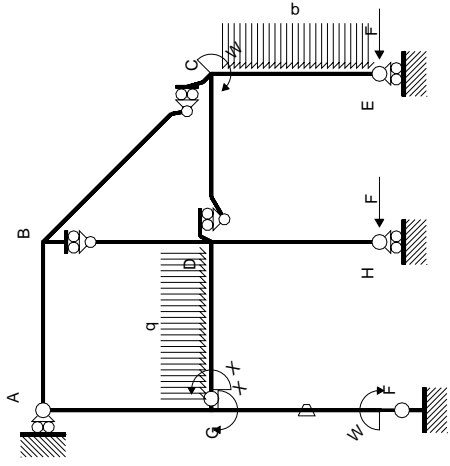

Schema di calcolo iperstatico

M_0 flessione da carichi assegnati

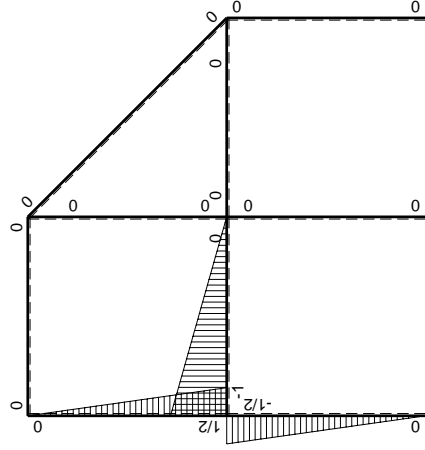

M_x flessione da iperstatica $X=1$

Quadro contributi PLV per iperstatica $X=W_{GD}$

→	$M_x(x)$	$M_o(x)$	θ	$M_x M_o$	$M_x \theta$	$M_x M_x$	$\int M_x(M_o/EJ+\theta)dx$	$\int X M_x M_x/EJdx$	
AB b	0	-2Fx	0	0	0	0	0+0	0	
BA b	0	2Fb-2Fx	0	0	0	0			
BC $\sqrt{2}b$	0	-2Fb+ $\sqrt{2}Fx$	0	0	0	0	0	0	
BD b	0	0	0	0	0	0	0+0	0	
DB b	0	0	0	0	0	0			
DC b	0	-5/2Fx	0	0	0	0	0+0	0	
CD b	0	5/2Fb-5/2Fx	0	0	0	0			
CE b	0	-3/2Fb+2Fx-1/2qx ²	0	0	0	0	0+0	0	
EC b	0	Fx+1/2qx ²	0	0	0	0			
FG b	-1/2x/b	Fb-Fx	-Fb/EJ	-1/2Fx+1/2Fx ² /b	1/2Fx/EJ	1/4x ² /b ²	(-1/12+1/4)Fb ² /EJ	1/12Xb/EJ	
GF b	1/2-1/2x/b	-Fx	Fb/EJ	-1/2Fx+1/2Fx ² /b	1/2Fb/EJ-1/2Fx/EJ	1/4-1/2x/b+1/4x ² /b ²			
GD b	-1+x/b	-1/2Fx-1/2qx ²	0	1/2Fx-1/2qx ³ /b	0	1-2x/b+x ² /b ²	(1/8+0)Fb ² /EJ	1/3Xb/EJ	
DG b	x/b	Fb-3/2Fx+1/2qx ²	0	Fx-3/2Fx ² /b+1/2qx ³ /b	0	x ² /b ²			
DH b	0	-Fb+Fx	0	0	0	0	0+0	0	
HD b	0	Fx	0	0	0	0			
GA b	1/2-1/2x/b	0	0	0	0	1/4-1/2x/b+1/4x ² /b ²	0+0	1/12Xb/EJ	
AG b	-1/2x/b	0	0	0	0	1/4x ² /b ²			
	totali							7/24Fb ² /EJ	1/2Xb/EJ
	iperstatica $X=W_{GD}$							-7/12Fb	

Sviluppi di calcolo iperstatica

$$L_{FG}^{xx} = \int_0^b (1/4 x^2/b^2) 1/EJ dx = [1/12 x^3/b^2]_0^b 1/EJ$$

$$= (1/12 b) 1/EJ = 1/12 b/EJ$$

$$L_{GF}^{xx} = \int_0^b (1/4 - 1/2 x/b + 1/4 x^2/b^2) 1/EJ dx = [1/4 x - 1/4 x^2/b + 1/12 x^3/b^2]_0^b 1/EJ$$

$$= (1/4 b - 1/4 b + 1/12 b) 1/EJ = 1/12 b/EJ$$

$$L_{GD}^{xx} = \int_0^b (1 - 2 x/b + x^2/b^2) 1/EJ dx = [x - x^2/b + 1/3 x^3/b^2]_0^b 1/EJ$$

$$= (b - b + 1/3 b) 1/EJ = 1/3 b/EJ$$

$$L_{DG}^{xx} = \int_0^b (x^2/b^2) 1/EJ dx = [1/3 x^3/b^2]_0^b 1/EJ$$

$$= (1/3 b) 1/EJ = 1/3 b/EJ$$

$$L_{GA}^{xx} = \int_0^b (1/4 - 1/2 x/b + 1/4 x^2/b^2) 1/EJ dx = [1/4 x - 1/4 x^2/b + 1/12 x^3/b^2]_0^b 1/EJ$$

$$= (1/4 b - 1/4 b + 1/12 b) 1/EJ = 1/12 b/EJ$$

$$L_{AG}^{xx} = \int_0^b (1/4 x^2/b^2) 1/EJ dx = [1/12 x^3/b^2]_0^b 1/EJ$$

$$= (1/12 b) 1/EJ = 1/12 b/EJ$$

$$L_{FG}^{xo} = \int_0^b (-1/2 x/b + 1/2 x^2/b^2) Fb 1/EJ dx + \int_0^b (1/2 x/b) \theta dx$$

$$= [-1/4 x^2/b + 1/6 x^3/b^2]_0^b Fb 1/EJ + [1/4 x^2/b]_0^b \theta$$

$$= (-1/4 b + 1/6 b) Fb 1/EJ + (1/4 b) \theta = 1/6 Fb^2/EJ$$

$$L_{GF}^{xo} = \int_0^b (-1/2 x/b + 1/2 x^2/b^2) Fb 1/EJ dx + \int_0^b (-1/2 + 1/2 x/b) \theta dx$$

$$= [-1/4 x^2/b + 1/6 x^3/b^2]_0^b Fb 1/EJ + [-1/2 x + 1/4 x^2/b]_0^b \theta$$

$$= (-1/4 b + 1/6 b) Fb 1/EJ + (-1/2 b + 1/4 b) \theta = 1/6 Fb^2/EJ$$

$$L_{GD}^{xo} = \int_0^b (1/2 x/b - 1/2 x^3/b^3) Fb 1/EJ dx = [1/4 x^2/b - 1/8 x^4/b^3]_0^b Fb 1/EJ$$

$$= (1/4 b - 1/8 b) Fb 1/EJ = 1/8 Fb^2/EJ$$

$$L_{DG}^{xo} = \int_0^b (x/b - 3/2 x^2/b^2 + 1/2 x^3/b^3) Fb 1/EJ dx = [1/2 x^2/b - 1/2 x^3/b^2 + 1/8 x^4/b^3]_0^b Fb 1/EJ$$

$$= (1/2 b - 1/2 b + 1/8 b) Fb 1/EJ = 1/8 Fb^2/EJ$$

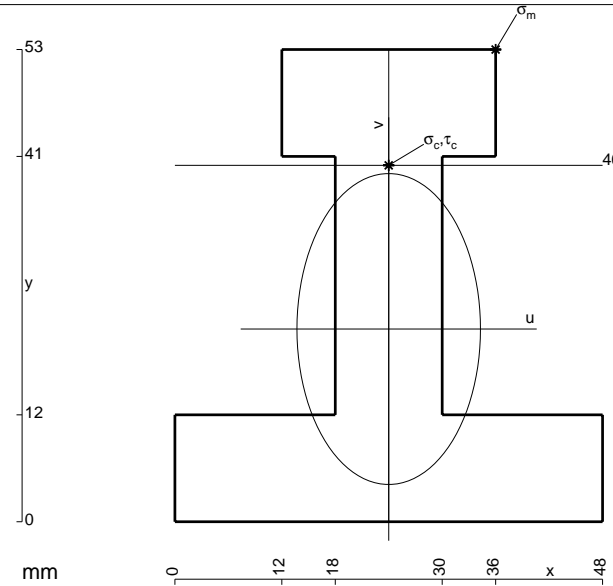

- A = 1212. mm²
- J_u = 369093. mm⁴
- J_v = 128592. mm⁴
- y_g = 21.63 mm
- T_y = -4150. N
- M_x = -2697500. Nmm
- x_m = 36. mm
- y_m = 53. mm
- u_m = 12. mm
- v_m = 31.37 mm
- σ_m = -Mv/J_u = 229.3 N/mm²
- x_c = 24. mm
- y_c = 40. mm
- v_c = 18.37 mm
- σ_c = -Mv/J_u = 134.3 N/mm²
- τ_c = 7.059 N/mm²
- σ_q = √σ²+3τ² = 134.8 N/mm²
- S = 7533. mm³

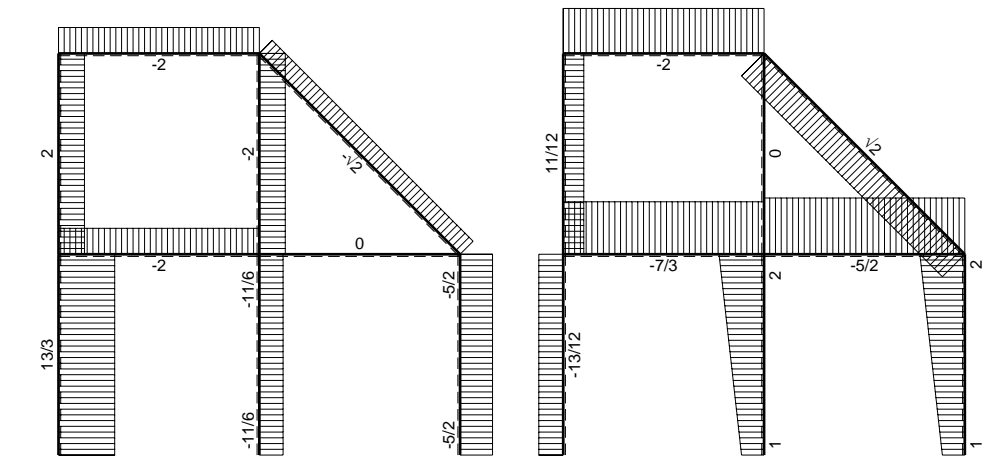
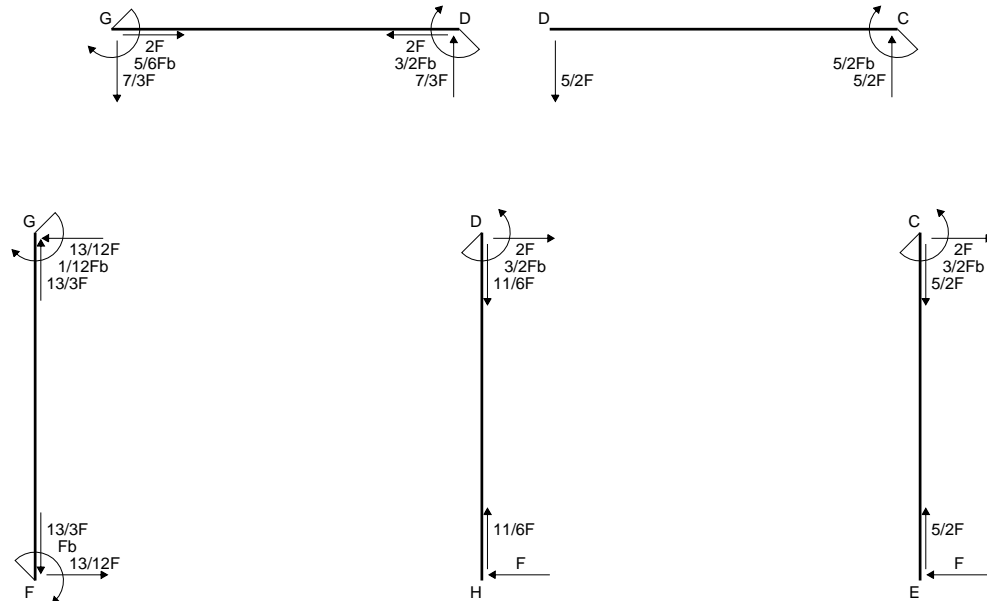
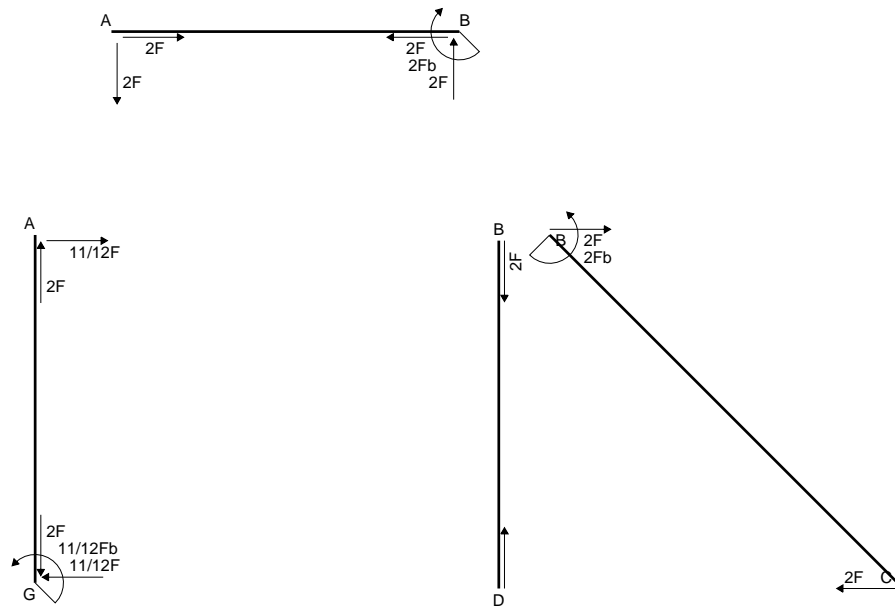

← ⊕ → F

↑ ⊕ ↓ F_b

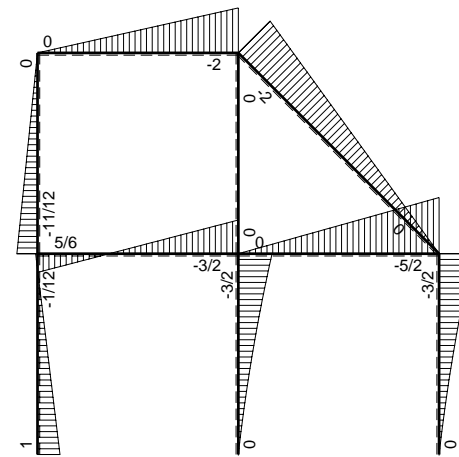

← ⊕ → F_b

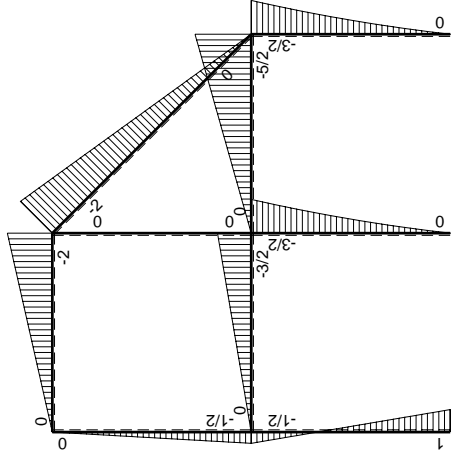
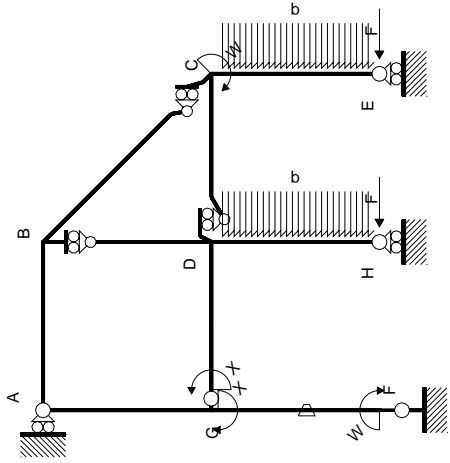

Schema di calcolo iperstatico

M_0 flessione da carichi assegnati

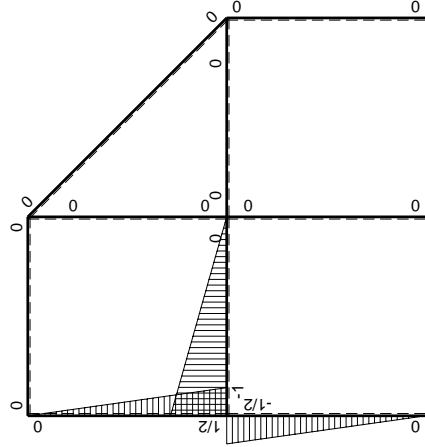

M_x flessione da iperstatica $X=1$

Quadro contributi PLV per iperstatica $X=W_{GD}$

→	$M_x(x)$	$M_o(x)$	θ	$M_x M_o$	$M_x \theta$	$M_x M_x$	$\int M_x(M_o/EJ+\theta)dx$	$\int X M_x M_x/EJ dx$
AB b	0	-2Fx	0	0	0	0	0+0	0
BA b	0	2Fb-2Fx	0	0	0	0	0	0
BC $\sqrt{2}b$	0	-2Fb+ $\sqrt{2}Fx$	0	0	0	0	0	0
BD b	0	0	0	0	0	0	0+0	0
DB b	0	0	0	0	0	0	0	0
DC b	0	-5/2Fx	0	0	0	0	0+0	0
CD b	0	5/2Fb-5/2Fx	0	0	0	0	0	0
CE b	0	-3/2Fb+2Fx-1/2qx ²	0	0	0	0	0+0	0
EC b	0	Fx+1/2qx ²	0	0	0	0	0	0
FG b	-1/2x/b	Fb-3/2Fx	-Fb/EJ	-1/2Fx+3/4Fx ² /b	1/2Fx/EJ	1/4x ² /b ²	(0+1/4)Fb ² /EJ	1/12Xb/EJ
GF b	1/2-1/2x/b	1/2Fb-3/2Fx	Fb/EJ	1/4Fb-Fx+3/4Fx ² /b	1/2Fb/EJ-1/2Fx/EJ	1/4-1/2x/b+1/4x ² /b ²		
GD b	-1+x/b	-3/2Fx	0	3/2Fx-3/2Fx ² /b	0	1-2x/b+x ² /b ²	(1/4+0)Fb ² /EJ	1/3Xb/EJ
DG b	x/b	3/2Fb-3/2Fx	0	3/2Fx-3/2Fx ² /b	0	x ² /b ²		
DH b	0	-3/2Fb+2Fx-1/2qx ²	0	0	0	0	0+0	0
HD b	0	Fx+1/2qx ²	0	0	0	0	0	0
GA b	1/2-1/2x/b	-1/2Fb+1/2Fx	0	-1/4Fb+1/2Fx-1/4Fx ² /b	0	1/4-1/2x/b+1/4x ² /b ²	(-1/12+0)Fb ² /EJ	1/12Xb/EJ
AG b	-1/2x/b	1/2Fx	0	-1/4Fx ² /b	0	1/4x ² /b ²		
	totali						5/12Fb ² /EJ	1/2Xb/EJ
	iperstatica $X=W_{GD}$						-5/6Fb	

Sviluppi di calcolo iperstatica

$$L_{FG}^{xx} = \int_0^b (1/4 x^2/b^2) 1/EJ dx = [1/12 x^3/b^2]_0^b 1/EJ$$

$$= (1/12 b) 1/EJ = 1/12 b/EJ$$

$$L_{GF}^{xx} = \int_0^b (1/4 - 1/2 x/b + 1/4 x^2/b^2) 1/EJ dx = [1/4 x - 1/4 x^2/b + 1/12 x^3/b^2]_0^b 1/EJ$$

$$= (1/4 b - 1/4 b + 1/12 b) 1/EJ = 1/12 b/EJ$$

$$L_{GD}^{xx} = \int_0^b (1 - 2 x/b + x^2/b^2) 1/EJ dx = [x - x^2/b + 1/3 x^3/b^2]_0^b 1/EJ$$

$$= (b - b + 1/3 b) 1/EJ = 1/3 b/EJ$$

$$L_{DG}^{xx} = \int_0^b (x^2/b^2) 1/EJ dx = [1/3 x^3/b^2]_0^b 1/EJ$$

$$= (1/3 b) 1/EJ = 1/3 b/EJ$$

$$L_{GA}^{xx} = \int_0^b (1/4 - 1/2 x/b + 1/4 x^2/b^2) 1/EJ dx = [1/4 x - 1/4 x^2/b + 1/12 x^3/b^2]_0^b 1/EJ$$

$$= (1/4 b - 1/4 b + 1/12 b) 1/EJ = 1/12 b/EJ$$

$$L_{AG}^{xx} = \int_0^b (1/4 x^2/b^2) 1/EJ dx = [1/12 x^3/b^2]_0^b 1/EJ$$

$$= (1/12 b) 1/EJ = 1/12 b/EJ$$

$$L_{FG}^{xo} = \int_0^b (-1/2 x/b + 3/4 x^2/b^2) Fb 1/EJ dx + \int_0^b (1/2 x/b) \theta dx$$

$$= [-1/4 x^2/b + 1/4 x^3/b^2]_0^b Fb 1/EJ + [1/4 x^2/b]_0^b \theta$$

$$= (-1/4 b + 1/4 b) Fb 1/EJ + (1/4 b) \theta = 1/4 Fb^2/EJ$$

$$L_{GF}^{xo} = \int_0^b (1/4 - x/b + 3/4 x^2/b^2) Fb 1/EJ dx + \int_0^b (-1/2 + 1/2 x/b) \theta dx$$

$$= [1/4 x - 1/2 x^2/b + 1/4 x^3/b^2]_0^b Fb 1/EJ + [-1/2 x + 1/4 x^2/b]_0^b \theta$$

$$= (1/4 b - 1/2 b + 1/4 b) Fb 1/EJ + (-1/2 b + 1/4 b) \theta = 1/4 Fb^2/EJ$$

$$L_{GD}^{xo} = \int_0^b (3/2 x/b - 3/2 x^2/b^2) Fb 1/EJ dx = [3/4 x^2/b - 1/2 x^3/b^2]_0^b Fb 1/EJ$$

$$= (3/4 b - 1/2 b) Fb 1/EJ = 1/4 Fb^2/EJ$$

$$L_{DG}^{xo} = \int_0^b (3/2 x/b - 3/2 x^2/b^2) Fb 1/EJ dx = [3/4 x^2/b - 1/2 x^3/b^2]_0^b Fb 1/EJ$$

$$= (3/4 b - 1/2 b) Fb 1/EJ = 1/4 Fb^2/EJ$$

$$L_{GA}^{xo} = \int_0^b (-1/4 + 1/2 x/b - 1/4 x^2/b^2) Fb 1/EJ dx = [-1/4 x + 1/4 x^2/b - 1/12 x^3/b^2]_0^b Fb 1/EJ$$

$$= (-1/4 b + 1/4 b - 1/12 b) Fb 1/EJ = -1/12 Fb^2/EJ$$

$$L_{AG}^{xo} = \int_0^b (-1/4 x^2/b^2) Fb 1/EJ dx = [-1/12 x^3/b^2]_0^b Fb 1/EJ$$

$$= (-1/12 b) Fb 1/EJ = -1/12 Fb^2/EJ$$

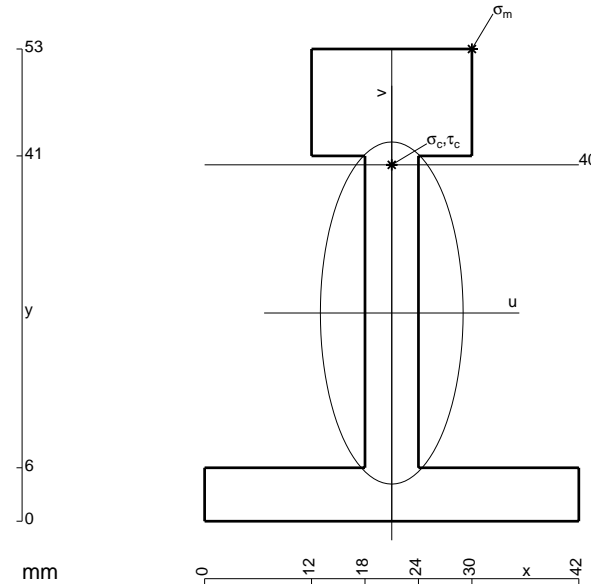

- A = 678. mm²
- J_u = 249963. mm⁴
- J_v = 43506. mm⁴
- y_g = 23.37 mm
- T_y = -2875. N
- M_x = -2012500. Nmm
- x_m = 30. mm
- u_m = 53. mm
- u_m = 9. mm
- v_m = 29.63 mm
- σ_m = -Mv/J_u = 238.6 N/mm²
- x_c = 21. mm
- y_c = 40. mm
- v_c = 16.63 mm
- σ_c = -Mv/J_u = 133.9 N/mm²
- τ_c = 9.982 N/mm²
- σ_o = √σ²+3τ² = 135. N/mm²
- S = 5207. mm³

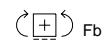
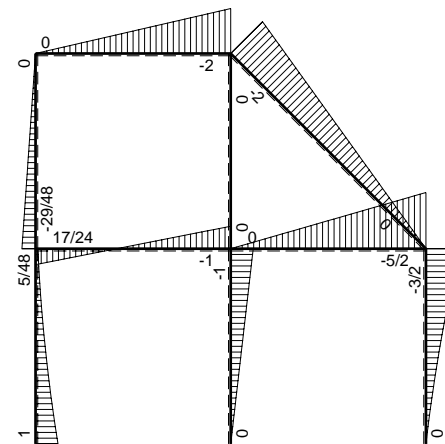
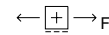
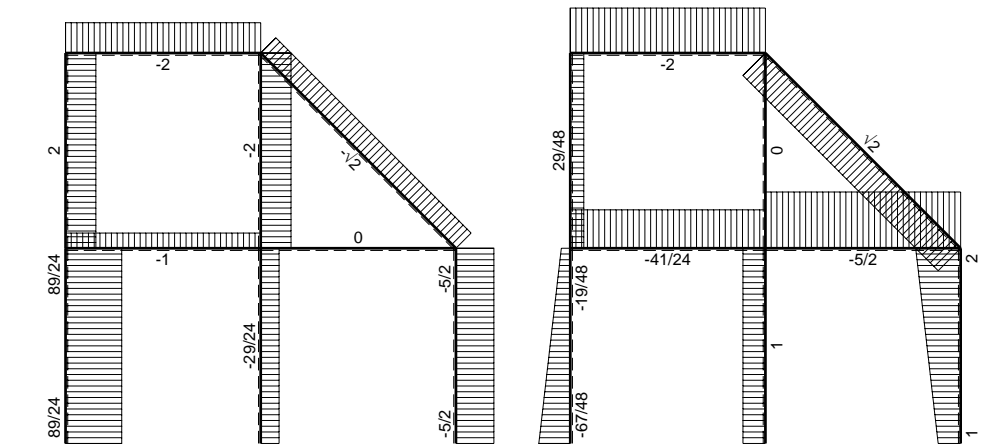
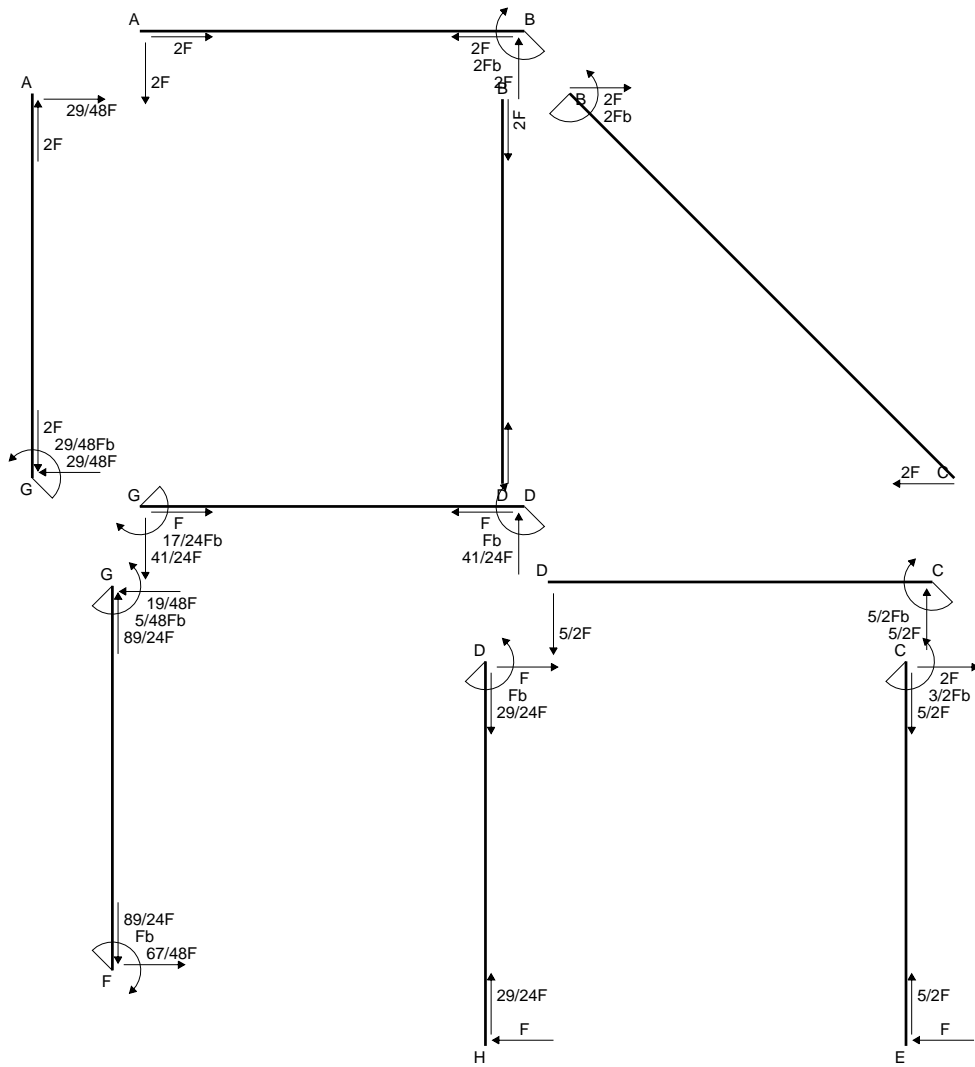

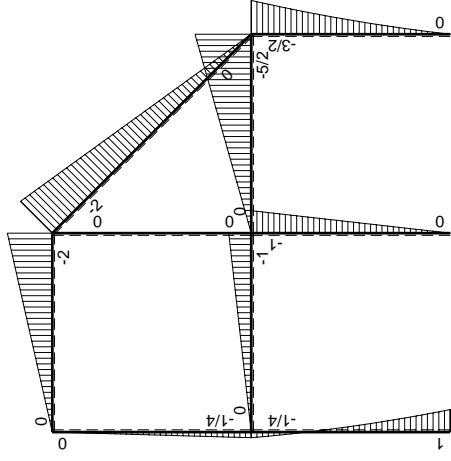
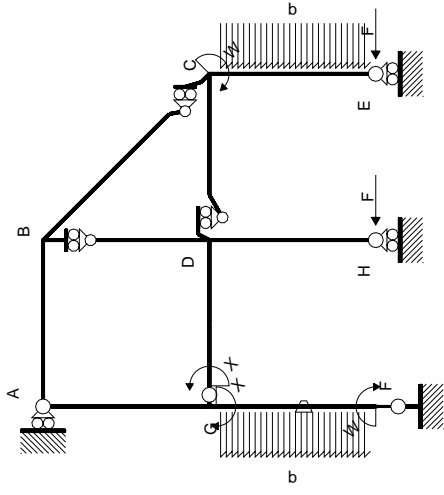

Schema di calcolo iperstatico

M_0 flessione da carichi assegnati

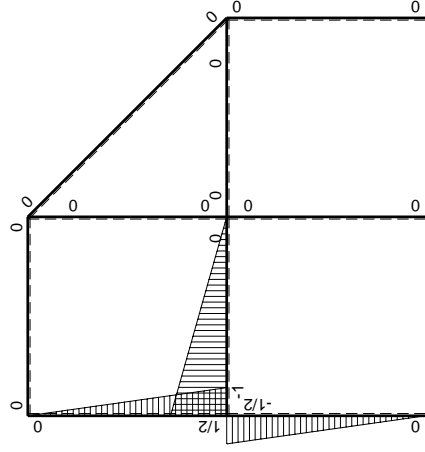

M_x flessione da iperstatica $X=1$

Quadro contributi PLV per iperstatica $X=W_{GD}$

→	$M_x(x)$	$M_o(x)$	θ	$M_x M_o$	$M_x \theta$	$M_x M_x$	$\int M_x(M_o/EJ+\theta)dx$	$\int X M_x M_x/EJ dx$	
AB b	0	-2Fx	0	0	0	0	0+0	0	
BA b	0	2Fb-2Fx	0	0	0	0	0	0	
BC $\sqrt{2}b$	0	-2Fb+ $\sqrt{2}Fx$	0	0	0	0	0	0	
BD b	0	0	0	0	0	0	0+0	0	
DB b	0	0	0	0	0	0	0	0	
DC b	0	-5/2Fx	0	0	0	0	0+0	0	
CD b	0	5/2Fb-5/2Fx	0	0	0	0	0	0	
CE b	0	-3/2Fb+2Fx-1/2qx ²	0	0	0	0	0+0	0	
EC b	0	Fx+1/2qx ²	0	0	0	0	0	0	
FG b	-1/2x/b	Fb-7/4Fx+1/2qx ²	-Fb/EJ	-1/2Fx+7/8Fx ² /b-1/4qx ³ /b	1/2Fx/EJ	1/4x ² /b ²	(-1/48+1/4)Fb ² /EJ	1/12Xb/EJ	
GF b	1/2-1/2x/b	1/4Fb-3/4Fx-1/2qx ²	Fb/EJ	1/8Fb-1/2Fx+1/8Fx ² /b+1/4qx ³ /b	1/2Fb/EJ-1/2Fx/EJ	1/4-1/2x/b+1/4x ² /b ²			
GD b	-1+x/b	-Fx	0	Fx-Fx ² /b	0	1-2x/b+x ² /b ²	(1/6+0)Fb ² /EJ	1/3Xb/EJ	
DG b	x/b	Fb-Fx	0	Fx-Fx ² /b	0	x ² /b ²			
DH b	0	-Fb+Fx	0	0	0	0	0+0	0	
HD b	0	Fx	0	0	0	0	0	0	
GA b	1/2-1/2x/b	-1/4Fb+1/4Fx	0	-1/8Fb+1/4Fx-1/8Fx ² /b	0	1/4-1/2x/b+1/4x ² /b ²	(-1/24+0)Fb ² /EJ	1/12Xb/EJ	
AG b	-1/2x/b	1/4Fx	0	-1/8Fx ² /b	0	1/4x ² /b ²			
	totali							17/48Fb ² /EJ	1/2Xb/EJ
	iperstatica $X=W_{GD}$							-17/24Fb	

Sviluppi di calcolo iperstatica

$$L_{FG}^{xx} = \int_0^b (1/4 x^2/b^2) 1/EJ dx = [1/12 x^3/b^2]_0^b 1/EJ$$

$$= (1/12 b) 1/EJ = 1/12 b/EJ$$

$$L_{GF}^{xx} = \int_0^b (1/4 - 1/2 x/b + 1/4 x^2/b^2) 1/EJ dx = [1/4 x - 1/4 x^2/b + 1/12 x^3/b^2]_0^b 1/EJ$$

$$= (1/4 b - 1/4 b + 1/12 b) 1/EJ = 1/12 b/EJ$$

$$L_{GD}^{xx} = \int_0^b (1 - 2 x/b + x^2/b^2) 1/EJ dx = [x - x^2/b + 1/3 x^3/b^2]_0^b 1/EJ$$

$$= (b - b + 1/3 b) 1/EJ = 1/3 b/EJ$$

$$L_{DG}^{xx} = \int_0^b (x^2/b^2) 1/EJ dx = [1/3 x^3/b^2]_0^b 1/EJ$$

$$= (1/3 b) 1/EJ = 1/3 b/EJ$$

$$L_{GA}^{xx} = \int_0^b (1/4 - 1/2 x/b + 1/4 x^2/b^2) 1/EJ dx = [1/4 x - 1/4 x^2/b + 1/12 x^3/b^2]_0^b 1/EJ$$

$$= (1/4 b - 1/4 b + 1/12 b) 1/EJ = 1/12 b/EJ$$

$$L_{AG}^{xx} = \int_0^b (1/4 x^2/b^2) 1/EJ dx = [1/12 x^3/b^2]_0^b 1/EJ$$

$$= (1/12 b) 1/EJ = 1/12 b/EJ$$

$$L_{FG}^{xo} = \int_0^b (-1/2 x/b + 7/8 x^2/b^2 - 1/4 x^3/b^3) Fb 1/EJ dx + \int_0^b (1/2 x/b) \theta dx$$

$$= [-1/4 x^2/b + 7/24 x^3/b^2 - 1/16 x^4/b^3]_0^b Fb 1/EJ + [1/4 x^2/b]_0^b \theta$$

$$= (-1/4 b + 7/24 b - 1/16 b) Fb 1/EJ + (1/4 b) \theta = 11/48 Fb^2/EJ$$

$$L_{GF}^{xo} = \int_0^b (1/8 - 1/2 x/b + 1/8 x^2/b^2 + 1/4 x^3/b^3) Fb 1/EJ dx + \int_0^b (-1/2 + 1/2 x/b) \theta dx$$

$$= [1/8 x - 1/4 x^2/b + 1/24 x^3/b^2 + 1/16 x^4/b^3]_0^b Fb 1/EJ + [-1/2 x + 1/4 x^2/b]_0^b \theta$$

$$= (1/8 b - 1/4 b + 1/24 b + 1/16 b) Fb 1/EJ + (-1/2 b + 1/4 b) \theta = 11/48 Fb^2/EJ$$

$$L_{GD}^{xo} = \int_0^b (x/b - x^2/b^2) Fb 1/EJ dx = [1/2 x^2/b - 1/3 x^3/b^2]_0^b Fb 1/EJ$$

$$= (1/2 b - 1/3 b) Fb 1/EJ = 1/6 Fb^2/EJ$$

$$L_{DG}^{xo} = \int_0^b (x/b - x^2/b^2) Fb 1/EJ dx = [1/2 x^2/b - 1/3 x^3/b^2]_0^b Fb 1/EJ$$

$$= (1/2 b - 1/3 b) Fb 1/EJ = 1/6 Fb^2/EJ$$

$$L_{GA}^{xo} = \int_0^b (-1/8 + 1/4 x/b - 1/8 x^2/b^2) Fb 1/EJ dx = [-1/8 x + 1/8 x^2/b - 1/24 x^3/b^2]_0^b Fb 1/EJ$$

$$= (-1/8 b + 1/8 b - 1/24 b) Fb 1/EJ = -1/24 Fb^2/EJ$$

$$L_{AG}^{xo} = \int_0^b (-1/8 x^2/b^2) Fb 1/EJ dx = [-1/24 x^3/b^2]_0^b Fb 1/EJ$$

$$= (-1/24 b) Fb 1/EJ = -1/24 Fb^2/EJ$$

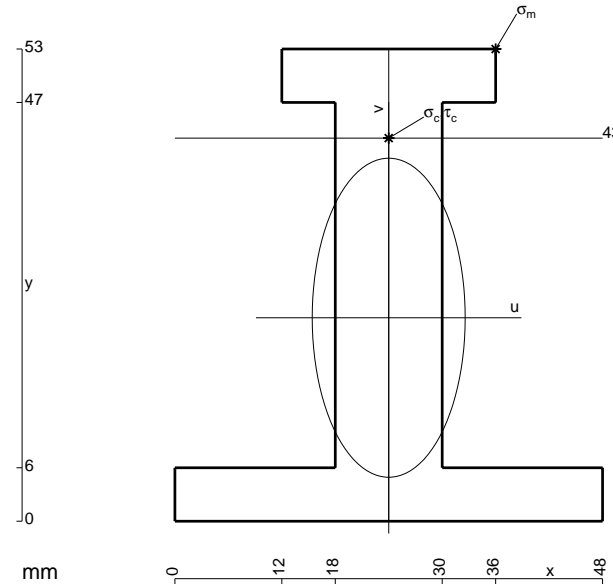

- A = 924. mm²
- J_u = 296396. mm⁴
- J_v = 68112. mm⁴
- y_g = 22.84 mm
- T_y = -2600. N
- M_x = -1950000. Nmm
- x_m = 36. mm
- y_m = 53. mm
- u_m = 12. mm
- v_m = 30.16 mm
- σ_m = -Mv/J_u = 198.4 N/mm²
- x_c = 24. mm
- y_c = 43. mm
- v_c = 20.16 mm
- σ_c = -Mv/J_u = 132.6 N/mm²
- τ_c = 3.637 N/mm²
- σ_o = √σ²+3τ² = 132.8 N/mm²
- S = 4975. mm³

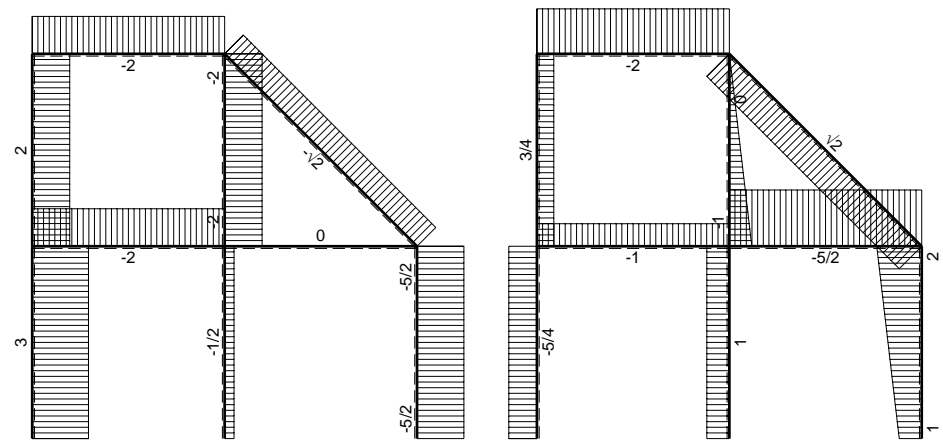
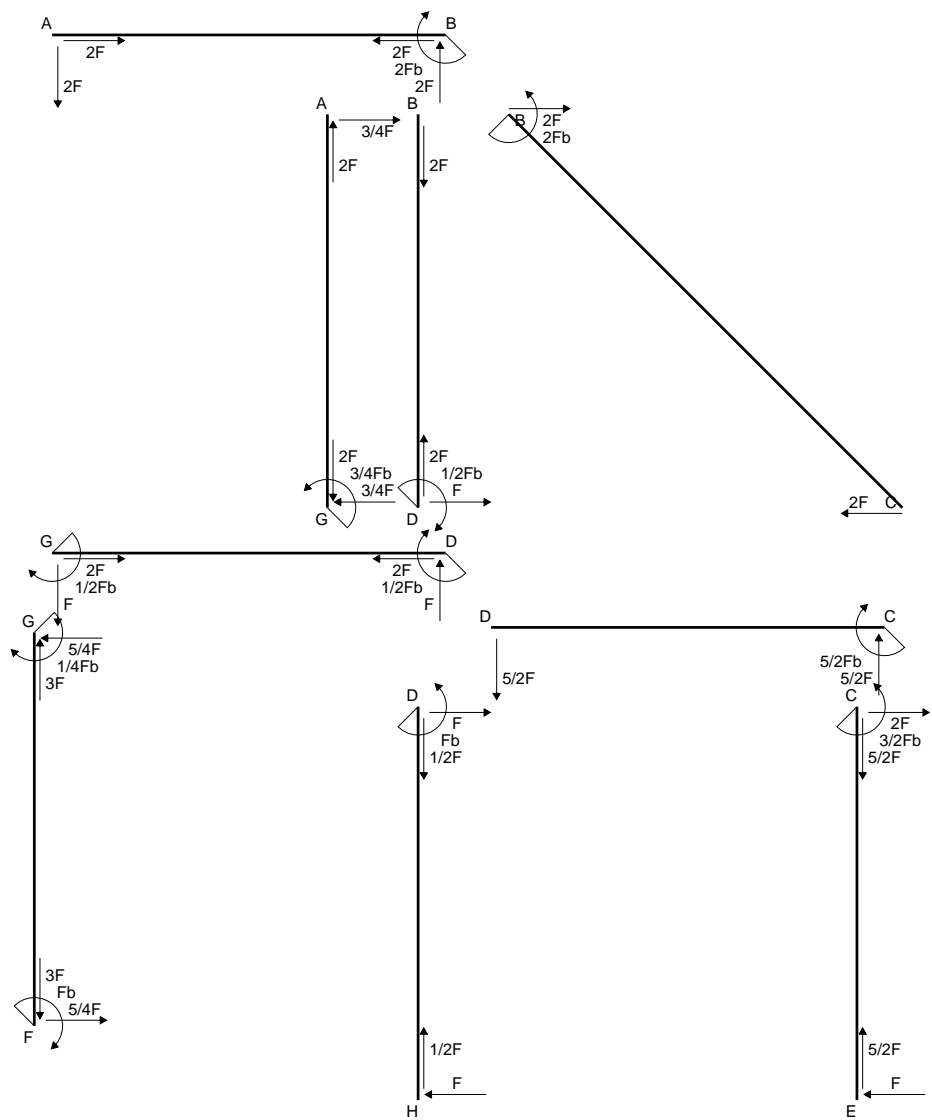

← ⊕ → F

↑ ⊕ ↓ F

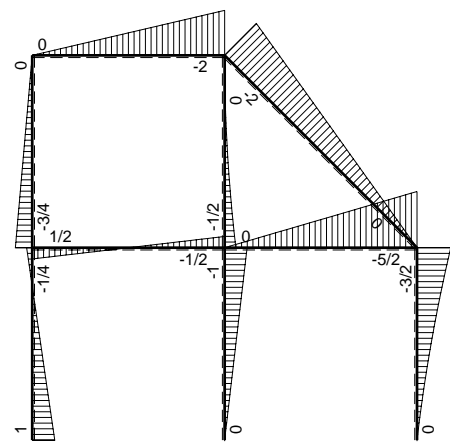

⊕ ⊖ F_b

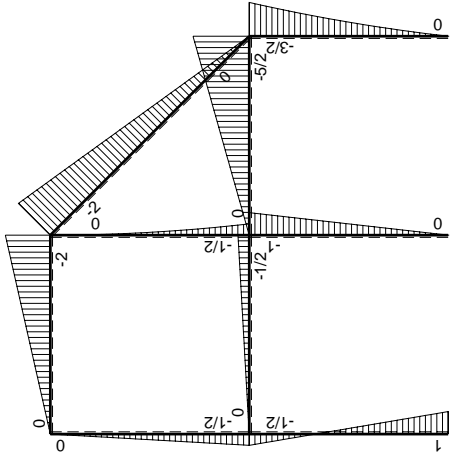
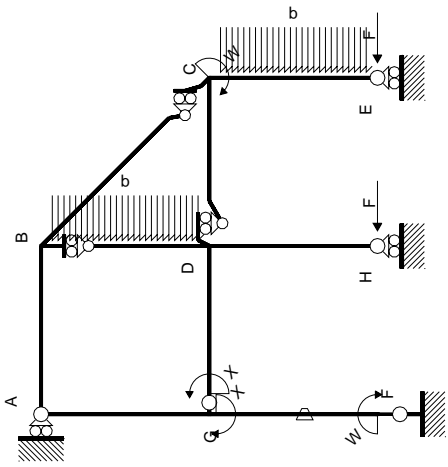

Schema di calcolo iperstatico

M_0 flessione da carichi assegnati

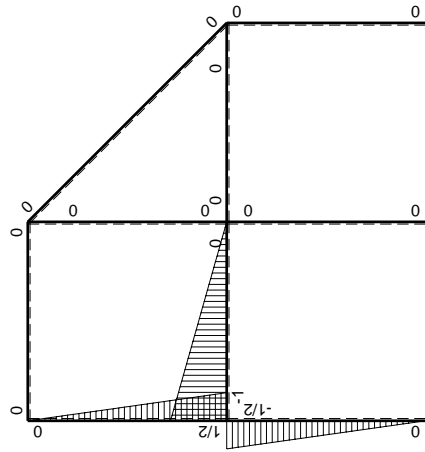

M_1 flessione da iperstatica X=1

Quadro contributi PLV per iperstatica $X=W_{GD}$

→	$M_x(x)$	$M_o(x)$	θ	$M_x M_o$	$M_x \theta$	$M_x M_x$	$\int M_x(M_o/EJ+\theta)dx$	$\int X M_x M_x / EJ dx$
AB b	0	-2Fx	0	0	0	0	0+0	0
BA b	0	2Fb-2Fx	0	0	0	0		
BC $\sqrt{2}b$	0	-2Fb+ $\sqrt{2}Fx$	0	0	0	0	0	0
BD b	0	-1/2qx ²	0	0	0	0	0+0	0
DB b	0	1/2Fb-Fx+1/2qx ²	0	0	0	0		
DC b	0	-5/2Fx	0	0	0	0	0+0	0
CD b	0	5/2Fb-5/2Fx	0	0	0	0		
CE b	0	-3/2Fb+2Fx-1/2qx ²	0	0	0	0	0+0	0
EC b	0	Fx+1/2qx ²	0	0	0	0		
FG b	-1/2x/b	Fb-3/2Fx	-Fb/EJ	-1/2Fx+3/4Fx ² /b	1/2Fx/EJ	1/4x ² /b ²	(0+1/4)Fb ² /EJ	1/12Xb/EJ
GF b	1/2-1/2x/b	1/2Fb-3/2Fx	Fb/EJ	1/4Fb-Fx+3/4Fx ² /b	1/2Fb/EJ-1/2Fx/EJ	1/4-1/2x/b+1/4x ² /b ²		
GD b	-1+x/b	-1/2Fx	0	1/2Fx-1/2Fx ² /b	0	1-2x/b+x ² /b ²	(1/12+0)Fb ² /EJ	1/3Xb/EJ
DG b	x/b	1/2Fb-1/2Fx	0	1/2Fx-1/2Fx ² /b	0	x ² /b ²		
DH b	0	-Fb+Fx	0	0	0	0	0+0	0
HD b	0	Fx	0	0	0	0		
GA b	1/2-1/2x/b	-1/2Fb+1/2Fx	0	-1/4Fb+1/2Fx-1/4Fx ² /b	0	1/4-1/2x/b+1/4x ² /b ²	(-1/12+0)Fb ² /EJ	1/12Xb/EJ
AG b	-1/2x/b	1/2Fx	0	-1/4Fx ² /b	0	1/4x ² /b ²		
	totali						1/4Fb ² /EJ	1/2Xb/EJ
	iperstatica $X=W_{GD}$						-1/2Fb	

Sviluppi di calcolo iperstatica

$$L_{FG}^{xx} = \int_0^b (1/4 x^2/b^2) 1/EJ dx = [1/12 x^3/b^2]_0^b 1/EJ$$

$$= (1/12 b) 1/EJ = 1/12 b/EJ$$

$$L_{GF}^{xx} = \int_0^b (1/4 - 1/2 x/b + 1/4 x^2/b^2) 1/EJ dx = [1/4 x - 1/4 x^2/b + 1/12 x^3/b^2]_0^b 1/EJ$$

$$= (1/4 b - 1/4 b + 1/12 b) 1/EJ = 1/12 b/EJ$$

$$L_{GD}^{xx} = \int_0^b (1 - 2 x/b + x^2/b^2) 1/EJ dx = [x - x^2/b + 1/3 x^3/b^2]_0^b 1/EJ$$

$$= (b - b + 1/3 b) 1/EJ = 1/3 b/EJ$$

$$L_{DG}^{xx} = \int_0^b (x^2/b^2) 1/EJ dx = [1/3 x^3/b^2]_0^b 1/EJ$$

$$= (1/3 b) 1/EJ = 1/3 b/EJ$$

$$L_{GA}^{xx} = \int_0^b (1/4 - 1/2 x/b + 1/4 x^2/b^2) 1/EJ dx = [1/4 x - 1/4 x^2/b + 1/12 x^3/b^2]_0^b 1/EJ$$

$$= (1/4 b - 1/4 b + 1/12 b) 1/EJ = 1/12 b/EJ$$

$$L_{AG}^{xx} = \int_0^b (1/4 x^2/b^2) 1/EJ dx = [1/12 x^3/b^2]_0^b 1/EJ$$

$$= (1/12 b) 1/EJ = 1/12 b/EJ$$

$$L_{FG}^{xo} = \int_0^b (-1/2 x/b + 3/4 x^2/b^2) Fb 1/EJ dx + \int_0^b (1/2 x/b) \theta dx$$

$$= [-1/4 x^2/b + 1/4 x^3/b^2]_0^b Fb 1/EJ + [1/4 x^2/b]_0^b \theta$$

$$= (-1/4 b + 1/4 b) Fb 1/EJ + (1/4 b) \theta = 1/4 Fb^2/EJ$$

$$L_{GF}^{xo} = \int_0^b (1/4 - x/b + 3/4 x^2/b^2) Fb 1/EJ dx + \int_0^b (-1/2 + 1/2 x/b) \theta dx$$

$$= [1/4 x - 1/2 x^2/b + 1/4 x^3/b^2]_0^b Fb 1/EJ + [-1/2 x + 1/4 x^2/b]_0^b \theta$$

$$= (1/4 b - 1/2 b + 1/4 b) Fb 1/EJ + (-1/2 b + 1/4 b) \theta = 1/4 Fb^2/EJ$$

$$L_{GD}^{xo} = \int_0^b (1/2 x/b - 1/2 x^2/b^2) Fb 1/EJ dx = [1/4 x^2/b - 1/6 x^3/b^2]_0^b Fb 1/EJ$$

$$= (1/4 b - 1/6 b) Fb 1/EJ = 1/12 Fb^2/EJ$$

$$L_{DG}^{xo} = \int_0^b (1/2 x/b - 1/2 x^2/b^2) Fb 1/EJ dx = [1/4 x^2/b - 1/6 x^3/b^2]_0^b Fb 1/EJ$$

$$= (1/4 b - 1/6 b) Fb 1/EJ = 1/12 Fb^2/EJ$$

$$L_{GA}^{xo} = \int_0^b (-1/4 + 1/2 x/b - 1/4 x^2/b^2) Fb 1/EJ dx = [-1/4 x + 1/4 x^2/b - 1/12 x^3/b^2]_0^b Fb 1/EJ$$

$$= (-1/4 b + 1/4 b - 1/12 b) Fb 1/EJ = -1/12 Fb^2/EJ$$

$$L_{AG}^{xo} = \int_0^b (-1/4 x^2/b^2) Fb 1/EJ dx = [-1/12 x^3/b^2]_0^b Fb 1/EJ$$

$$= (-1/12 b) Fb 1/EJ = -1/12 Fb^2/EJ$$

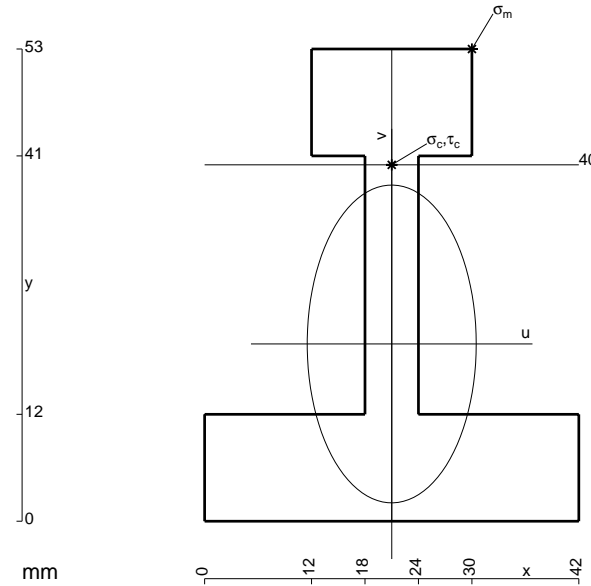

- A = 894. mm²
- J_u = 284424. mm⁴
- J_v = 80442. mm⁴
- y_g = 19.9 mm
- T_y = -2250. N
- M_x = -1800000. Nmm
- x_m = 30. mm
- y_m = 53. mm
- u_m = 9. mm
- v_m = 33.1 mm
- σ_m = -Mv/J_u = 209.5 N/mm²
- x_c = 21. mm
- y_c = 40. mm
- v_c = 20.1 mm
- σ_c = -Mv/J_u = 127.2 N/mm²
- τ_c = 7.882 N/mm²
- σ_o = √σ²+3τ² = 128. N/mm²
- S = 5978. mm³

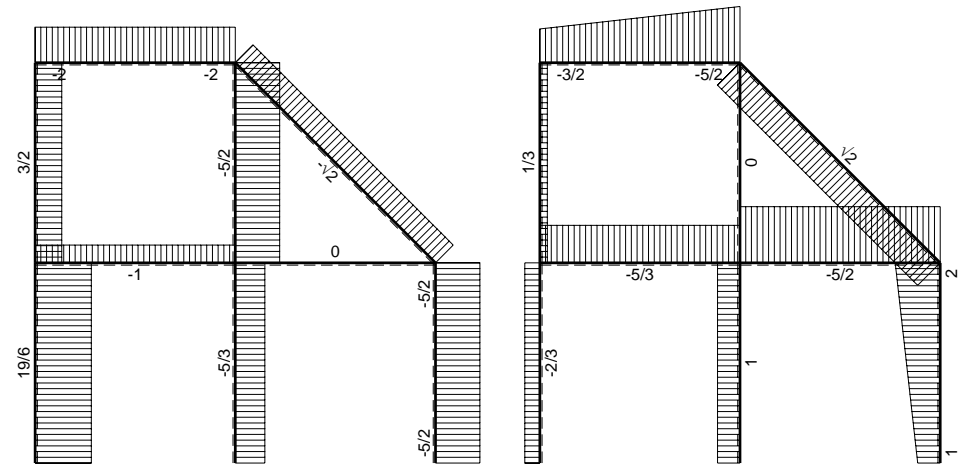
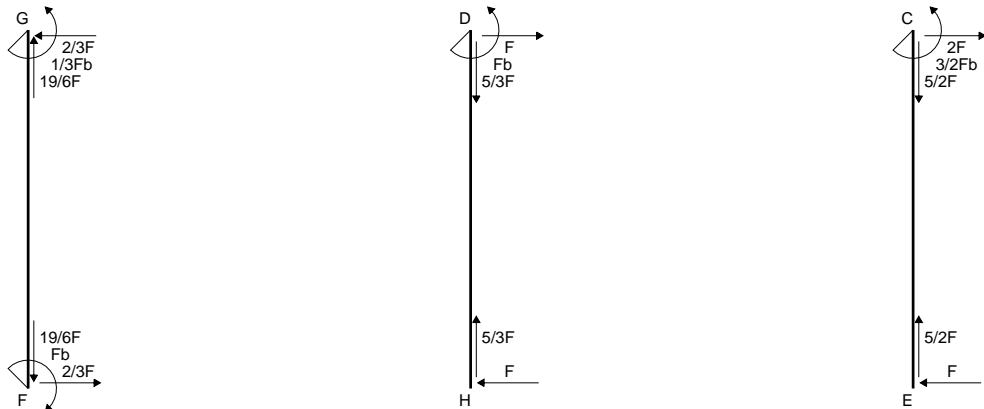
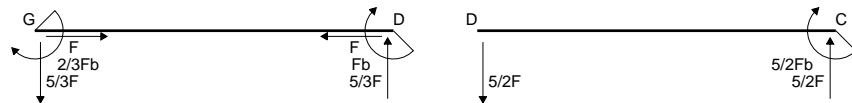
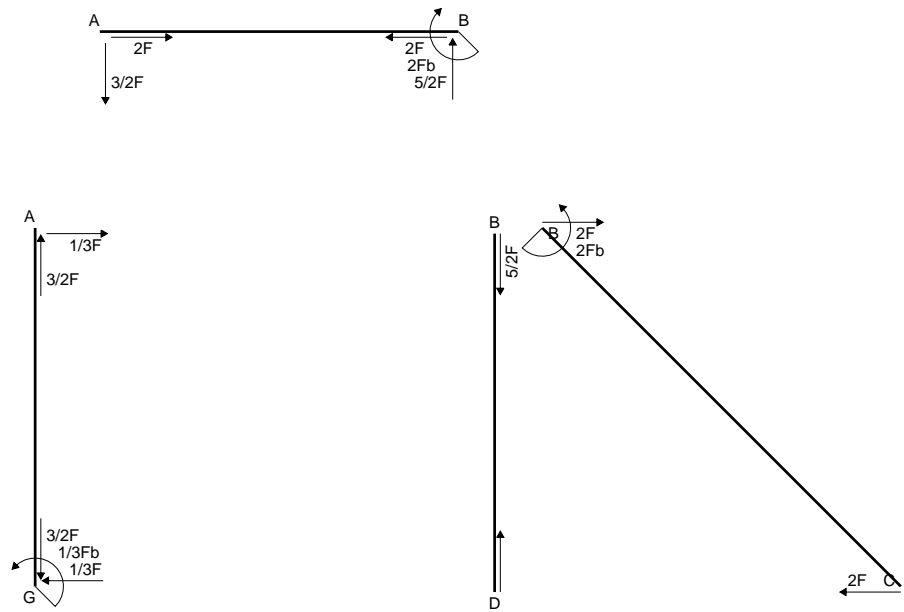

← ⊕ → F

↑ ⊕ ↓ F

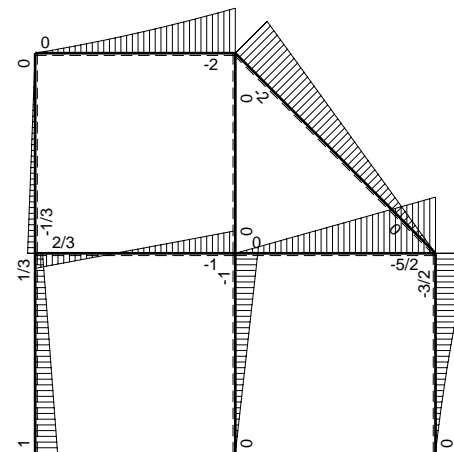

⊕ ⊖ Fb

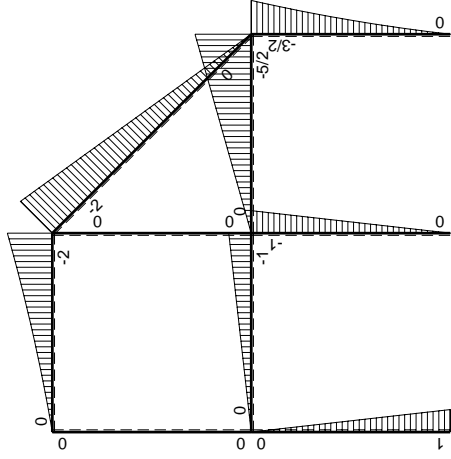
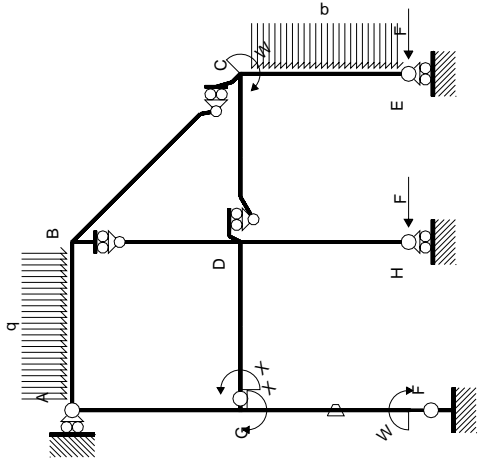

Schema di calcolo iperstatico

M_0 flessione da carichi assegnati

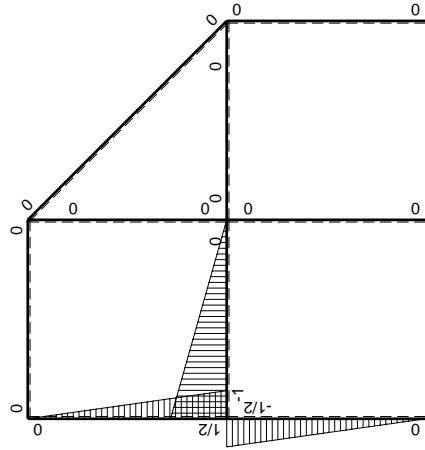

M_x flessione da iperstatica $X=1$

Quadro contributi PLV per iperstatica $X=W_{GD}$

→	$M_x(x)$	$M_o(x)$	θ	$M_x M_o$	$M_x \theta$	$M_x M_x$	$\int M_x(M_o/EJ+\theta)dx$	$\int X M_x M_x/EJdx$	
AB b	0	$-3/2Fx-1/2qx^2$	0	0	0	0	0+0	0	
BA b	0	$2Fb-5/2Fx+1/2qx^2$	0	0	0	0			
BC $\sqrt{2}b$	0	$-2Fb+\sqrt{2}Fx$	0	0	0	0	0	0	
BD b	0	0	0	0	0	0	0+0	0	
DB b	0	0	0	0	0	0			
DC b	0	$-5/2Fx$	0	0	0	0	0+0	0	
CD b	0	$5/2Fb-5/2Fx$	0	0	0	0			
CE b	0	$-3/2Fb+2Fx-1/2qx^2$	0	0	0	0	0+0	0	
EC b	0	$Fx+1/2qx^2$	0	0	0	0			
FG b	$-1/2x/b$	$Fb-Fx$	$-Fb/EJ$	$-1/2Fx+1/2Fx^2/b$	$1/2Fx/EJ$	$1/4x^2/b^2$	$(-1/12+1/4)Fb^2/EJ$	$1/12Xb/EJ$	
GF b	$1/2-1/2x/b$	$-Fx$	Fb/EJ	$-1/2Fx+1/2Fx^2/b$	$1/2Fb/EJ-1/2Fx/EJ$	$1/4-1/2x/b+1/4x^2/b^2$			
GD b	$-1+x/b$	$-Fx$	0	$Fx-Fx^2/b$	0	$1-2x/b+x^2/b^2$	$(1/6+0)Fb^2/EJ$	$1/3Xb/EJ$	
DG b	x/b	$Fb-Fx$	0	$Fx-Fx^2/b$	0	x^2/b^2			
DH b	0	$-Fb+Fx$	0	0	0	0	0+0	0	
HD b	0	Fx	0	0	0	0			
GA b	$1/2-1/2x/b$	0	0	0	0	$1/4-1/2x/b+1/4x^2/b^2$	0+0	$1/12Xb/EJ$	
AG b	$-1/2x/b$	0	0	0	0	$1/4x^2/b^2$			
	totali							$1/3Fb^2/EJ$	$1/2Xb/EJ$
	iperstatica $X=W_{GD}$							$-2/3Fb$	

Sviluppi di calcolo iperstatica

$$L_{FG}^{xx} = \int_0^b (1/4 x^2/b^2) 1/EJ dx = [1/12 x^3/b^2]_0^b 1/EJ$$

$$= (1/12 b) 1/EJ = 1/12 b/EJ$$

$$L_{GF}^{xx} = \int_0^b (1/4 - 1/2 x/b + 1/4 x^2/b^2) 1/EJ dx = [1/4 x - 1/4 x^2/b + 1/12 x^3/b^2]_0^b 1/EJ$$

$$= (1/4 b - 1/4 b + 1/12 b) 1/EJ = 1/12 b/EJ$$

$$L_{GD}^{xx} = \int_0^b (1 - 2 x/b + x^2/b^2) 1/EJ dx = [x - x^2/b + 1/3 x^3/b^2]_0^b 1/EJ$$

$$= (b - b + 1/3 b) 1/EJ = 1/3 b/EJ$$

$$L_{DG}^{xx} = \int_0^b (x^2/b^2) 1/EJ dx = [1/3 x^3/b^2]_0^b 1/EJ$$

$$= (1/3 b) 1/EJ = 1/3 b/EJ$$

$$L_{GA}^{xx} = \int_0^b (1/4 - 1/2 x/b + 1/4 x^2/b^2) 1/EJ dx = [1/4 x - 1/4 x^2/b + 1/12 x^3/b^2]_0^b 1/EJ$$

$$= (1/4 b - 1/4 b + 1/12 b) 1/EJ = 1/12 b/EJ$$

$$L_{AG}^{xx} = \int_0^b (1/4 x^2/b^2) 1/EJ dx = [1/12 x^3/b^2]_0^b 1/EJ$$

$$= (1/12 b) 1/EJ = 1/12 b/EJ$$

$$L_{FG}^{xo} = \int_0^b (-1/2 x/b + 1/2 x^2/b^2) Fb 1/EJ dx + \int_0^b (1/2 x/b) \theta dx$$

$$= [-1/4 x^2/b + 1/6 x^3/b^2]_0^b Fb 1/EJ + [1/4 x^2/b]_0^b \theta$$

$$= (-1/4 b + 1/6 b) Fb 1/EJ + (1/4 b) \theta = 1/6 Fb^2/EJ$$

$$L_{GF}^{xo} = \int_0^b (-1/2 x/b + 1/2 x^2/b^2) Fb 1/EJ dx + \int_0^b (-1/2 + 1/2 x/b) \theta dx$$

$$= [-1/4 x^2/b + 1/6 x^3/b^2]_0^b Fb 1/EJ + [-1/2 x + 1/4 x^2/b]_0^b \theta$$

$$= (-1/4 b + 1/6 b) Fb 1/EJ + (-1/2 b + 1/4 b) \theta = 1/6 Fb^2/EJ$$

$$L_{GD}^{xo} = \int_0^b (x/b - x^2/b^2) Fb 1/EJ dx = [1/2 x^2/b - 1/3 x^3/b^2]_0^b Fb 1/EJ$$

$$= (1/2 b - 1/3 b) Fb 1/EJ = 1/6 Fb^2/EJ$$

$$L_{DG}^{xo} = \int_0^b (x/b - x^2/b^2) Fb 1/EJ dx = [1/2 x^2/b - 1/3 x^3/b^2]_0^b Fb 1/EJ$$

$$= (1/2 b - 1/3 b) Fb 1/EJ = 1/6 Fb^2/EJ$$

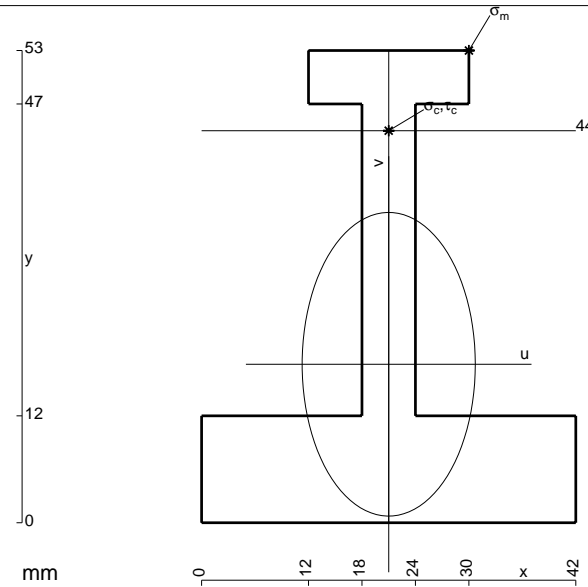

- A = 822. mm²
- J_u = 238712. mm⁴
- J_v = 77634. mm⁴
- y_g = 17.78 mm
- T_y = -1750. N
- M_x = -1487500. Nmm
- x_m = 30. mm
- y_m = 53. mm
- u_m = 9. mm
- v_m = 35.22 mm
- σ_m = -Mv/J_u = 219.4 N/mm²
- x_c = 21. mm
- y_c = 44. mm
- v_c = 26.22 mm
- σ_c = -Mv/J_u = 163.4 N/mm²
- τ_c = 4.861 N/mm²
- σ_q = √σ²+3τ² = 163.6 N/mm²
- S = 3978. mm³

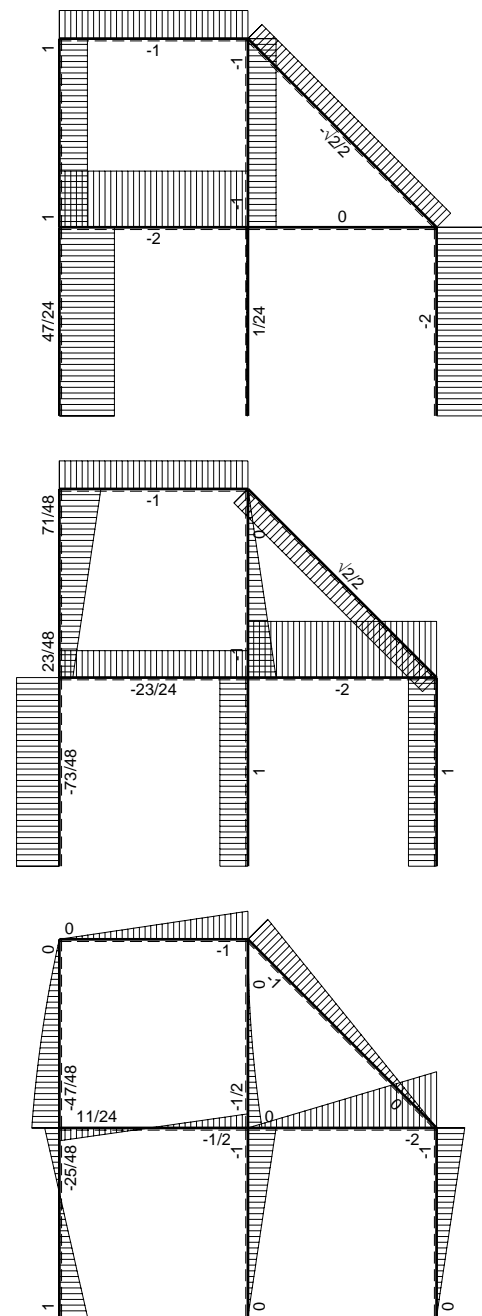
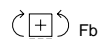
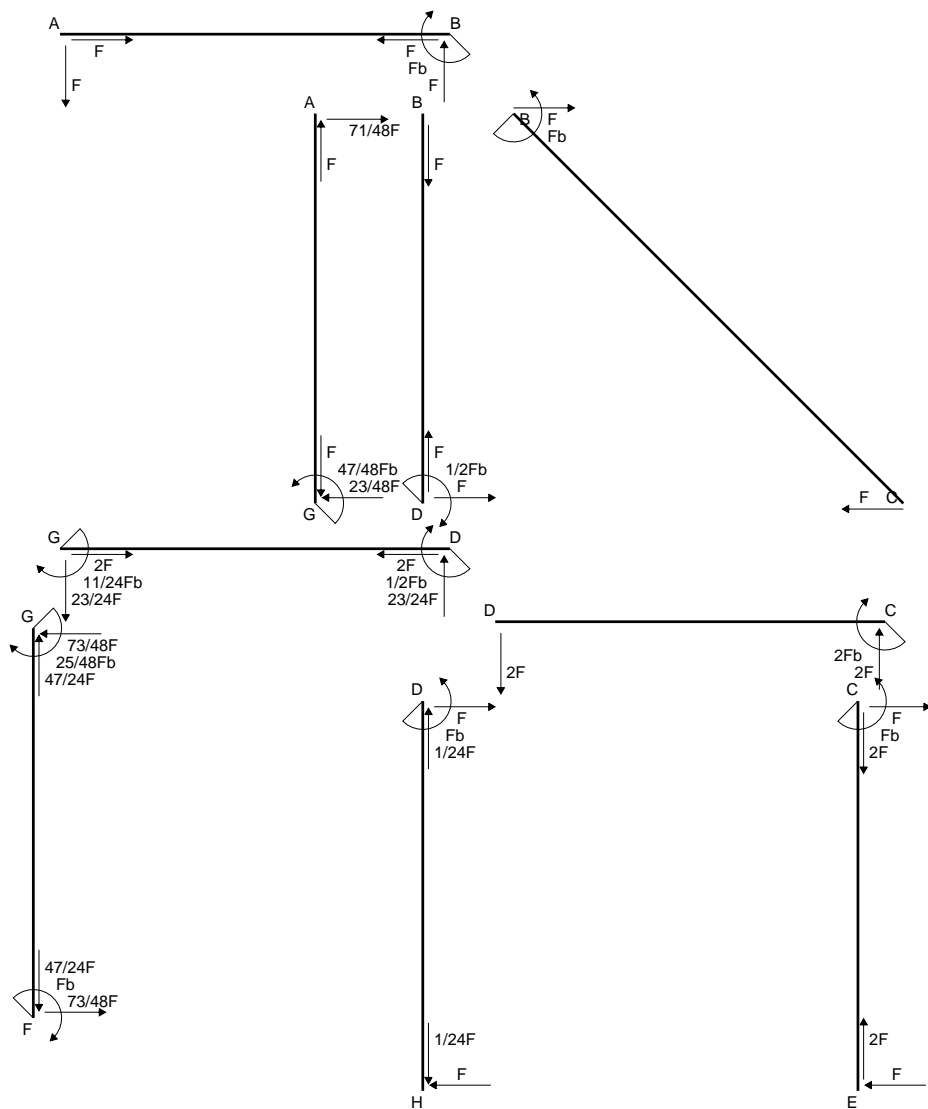

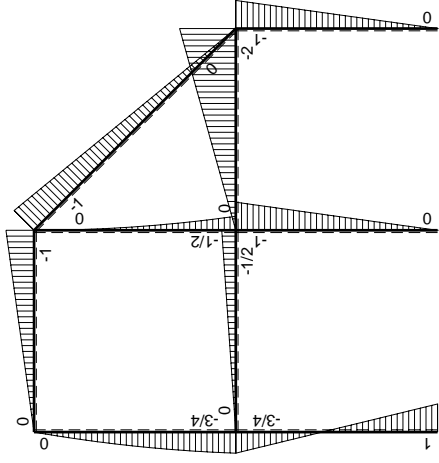
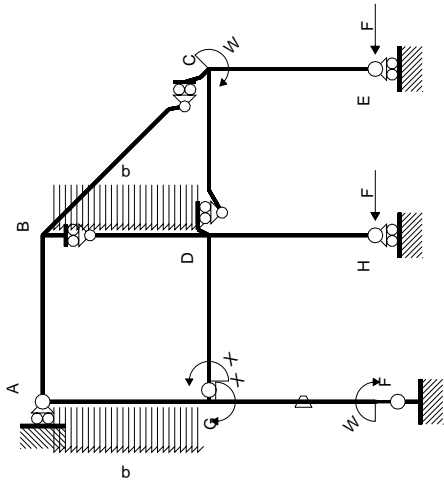

Schema di calcolo iperstatico

M_0 flessione da carichi assegnati

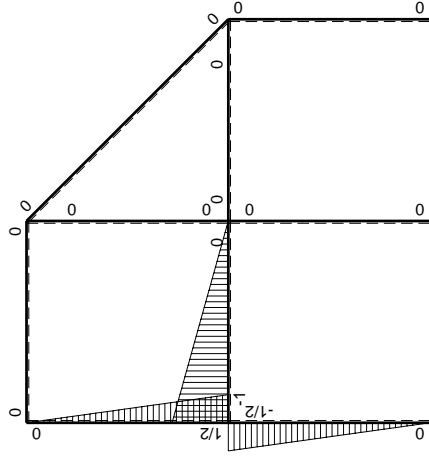

M_x flessione da iperstatica $X=1$

Quadro contributi PLV per iperstatica $X=W_{GD}$

→	$M_x(x)$	$M_o(x)$	θ	$M_x M_o$	$M_x \theta$	$M_x M_x$	$\int M_x(M_o/EJ+\theta)dx$	$\int X M_x M_x/EJ dx$	
AB b	0	-Fx	0	0	0	0	0+0	0	
BA b	0	Fb-Fx	0	0	0	0			
BC $\sqrt{2}b$	0	-Fb+ $\sqrt{2}/2Fx$	0	0	0	0	0	0	
BD b	0	-1/2qx ²	0	0	0	0	0+0	0	
DB b	0	1/2Fb-Fx+1/2qx ²	0	0	0	0			
DC b	0	-2Fx	0	0	0	0	0+0	0	
CD b	0	2Fb-2Fx	0	0	0	0			
CE b	0	-Fb+Fx	0	0	0	0	0+0	0	
EC b	0	Fx	0	0	0	0			
FG b	-1/2x/b	Fb-7/4Fx	-Fb/EJ	-1/2Fx+7/8Fx ² /b	1/2Fx/EJ	1/4x ² /b ²	(1/24+1/4)Fb ² /EJ	1/12Xb/EJ	
GF b	1/2-1/2x/b	3/4Fb-7/4Fx	Fb/EJ	3/8Fb-5/4Fx+7/8Fx ² /b	1/2Fb/EJ-1/2Fx/EJ	1/4-1/2x/b+1/4x ² /b ²			
GD b	-1+x/b	-1/2Fx	0	1/2Fx-1/2Fx ² /b	0	1-2x/b+x ² /b ²	(1/12+0)Fb ² /EJ	1/3Xb/EJ	
DG b	x/b	1/2Fb-1/2Fx	0	1/2Fx-1/2Fx ² /b	0	x ² /b ²			
DH b	0	-Fb+Fx	0	0	0	0	0+0	0	
HD b	0	Fx	0	0	0	0			
GA b	1/2-1/2x/b	-3/4Fb+1/4Fx+1/2qx ²	0	-3/8Fb+1/2Fx+1/8Fx ² /b-1/4qx ³ /b	0	1/4-1/2x/b+1/4x ² /b ²	(-7/48+0)Fb ² /EJ	1/12Xb/EJ	
AG b	-1/2x/b	5/4Fx-1/2qx ²	0	-5/8Fx ² /b+1/4qx ³ /b	0	1/4x ² /b ²			
	totali							11/48Fb ² /EJ	1/2Xb/EJ
	iperstatica $X=W_{GD}$							-11/24Fb	

Sviluppi di calcolo iperstatica

$$L_{FG}^{xx} = \int_0^b (1/4 x^2/b^2) 1/EJ dx = [1/12 x^3/b^2]_0^b 1/EJ$$

$$= (1/12 b) 1/EJ = 1/12 b/EJ$$

$$L_{GF}^{xx} = \int_0^b (1/4 -1/2 x/b +1/4 x^2/b^2) 1/EJ dx = [1/4 x -1/4 x^2/b +1/12 x^3/b^2]_0^b 1/EJ$$

$$= (1/4 b -1/4 b +1/12 b) 1/EJ = 1/12 b/EJ$$

$$L_{GD}^{xx} = \int_0^b (1 -2 x/b + x^2/b^2) 1/EJ dx = [x - x^2/b +1/3 x^3/b^2]_0^b 1/EJ$$

$$= (b - b +1/3 b) 1/EJ = 1/3 b/EJ$$

$$L_{DG}^{xx} = \int_0^b (x^2/b^2) 1/EJ dx = [1/3 x^3/b^2]_0^b 1/EJ$$

$$= (1/3 b) 1/EJ = 1/3 b/EJ$$

$$L_{GA}^{xx} = \int_0^b (1/4 -1/2 x/b +1/4 x^2/b^2) 1/EJ dx = [1/4 x -1/4 x^2/b +1/12 x^3/b^2]_0^b 1/EJ$$

$$= (1/4 b -1/4 b +1/12 b) 1/EJ = 1/12 b/EJ$$

$$L_{AG}^{xx} = \int_0^b (1/4 x^2/b^2) 1/EJ dx = [1/12 x^3/b^2]_0^b 1/EJ$$

$$= (1/12 b) 1/EJ = 1/12 b/EJ$$

$$L_{FG}^{xo} = \int_0^b (-1/2 x/b +7/8 x^2/b^2) Fb 1/EJ dx + \int_0^b (1/2 x/b) \theta dx$$

$$= [-1/4 x^2/b +7/24 x^3/b^2]_0^b Fb 1/EJ + [1/4 x^2/b]_0^b \theta$$

$$= (-1/4 b +7/24 b) Fb 1/EJ + (1/4 b) \theta = 7/24 Fb^2/EJ$$

$$L_{GF}^{xo} = \int_0^b (3/8 -5/4 x/b +7/8 x^2/b^2) Fb 1/EJ dx + \int_0^b (-1/2 +1/2 x/b) \theta dx$$

$$= [3/8 x -5/8 x^2/b +7/24 x^3/b^2]_0^b Fb 1/EJ + [-1/2 x +1/4 x^2/b]_0^b \theta$$

$$= (3/8 b -5/8 b +7/24 b) Fb 1/EJ + (-1/2 b +1/4 b) \theta = 7/24 Fb^2/EJ$$

$$L_{GD}^{xo} = \int_0^b (1/2 x/b -1/2 x^2/b^2) Fb 1/EJ dx = [1/4 x^2/b -1/6 x^3/b^2]_0^b Fb 1/EJ$$

$$= (1/4 b -1/6 b) Fb 1/EJ = 1/12 Fb^2/EJ$$

$$L_{DG}^{xo} = \int_0^b (1/2 x/b -1/2 x^2/b^2) Fb 1/EJ dx = [1/4 x^2/b -1/6 x^3/b^2]_0^b Fb 1/EJ$$

$$= (1/4 b -1/6 b) Fb 1/EJ = 1/12 Fb^2/EJ$$

$$L_{GA}^{xo} = \int_0^b (-3/8 +1/2 x/b +1/8 x^2/b^2 -1/4 x^3/b^3) Fb 1/EJ dx$$

$$= [-3/8 x +1/4 x^2/b +1/24 x^3/b^2 -1/16 x^4/b^3]_0^b Fb 1/EJ$$

$$= (-3/8 b +1/4 b +1/24 b -1/16 b) Fb 1/EJ = -7/48 Fb^2/EJ$$

$$L_{AG}^{xo} = \int_0^b (-5/8 x^2/b^2 +1/4 x^3/b^3) Fb 1/EJ dx = [-5/24 x^3/b^2 +1/16 x^4/b^3]_0^b Fb 1/EJ$$

$$= (-5/24 b +1/16 b) Fb 1/EJ = -7/48 Fb^2/EJ$$

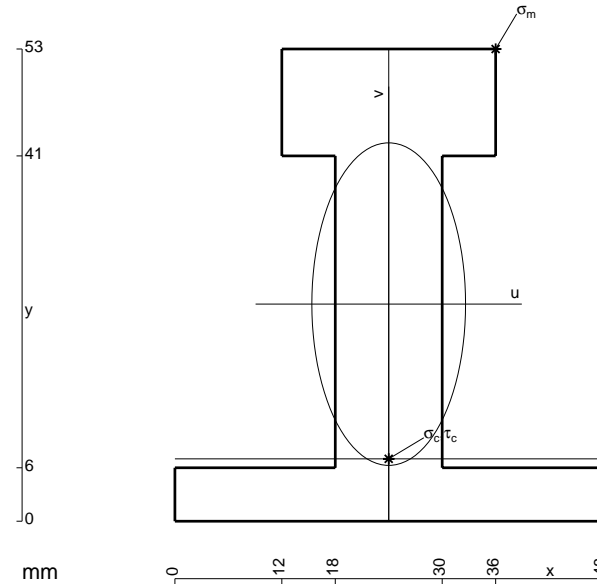

- A = 996. mm²
- J_u = 326526. mm⁴
- J_v = 74160. mm⁴
- y_g = 24.37 mm
- T_y = -2900. N
- M_x = -2610000. Nmm
- x_m = 36. mm
- y_m = 53. mm
- u_m = 12. mm
- v_m = 28.63 mm
- σ_m = -Mv/J_u = 228.9 N/mm²
- x_c = 24. mm
- y_c = 7. mm
- v_c = -17.37 mm
- σ_c = -Mv/J_u = -138.8 N/mm²
- τ_c = 4.713 N/mm²
- σ_o = √σ²+3τ² = 139.1 N/mm²
- S = 6368. mm³

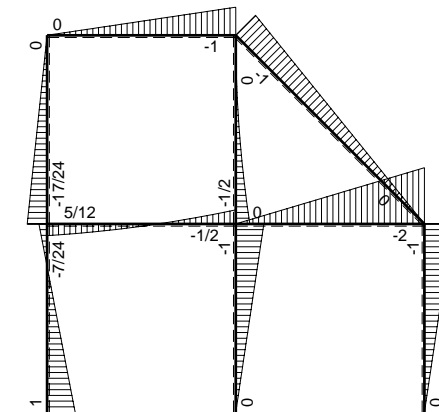
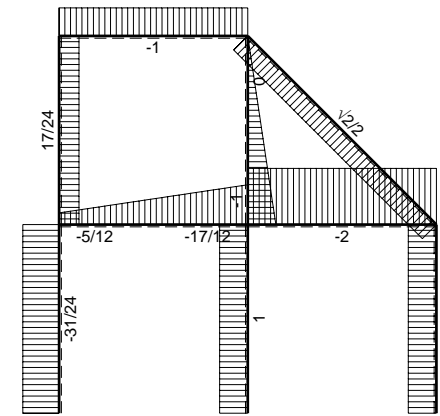
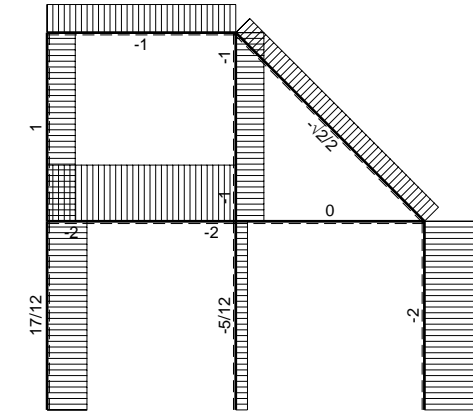
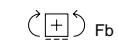
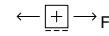
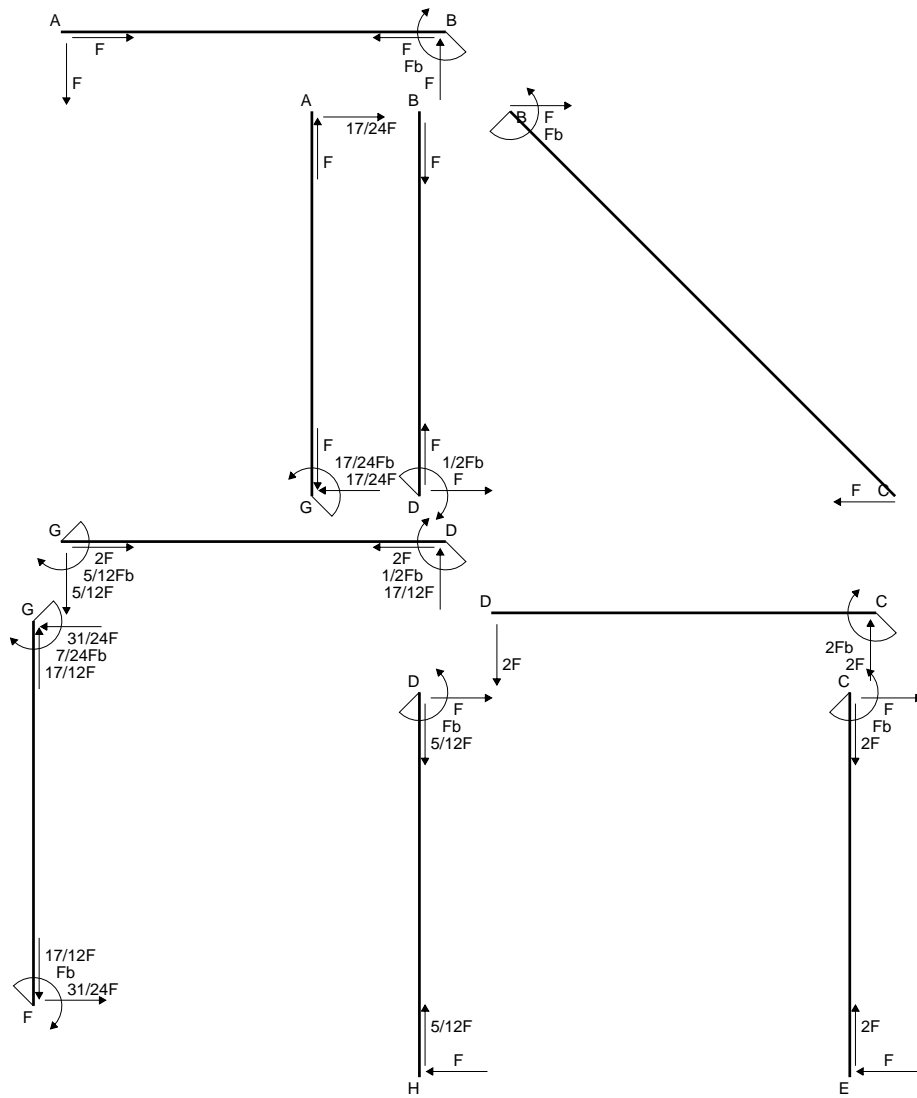

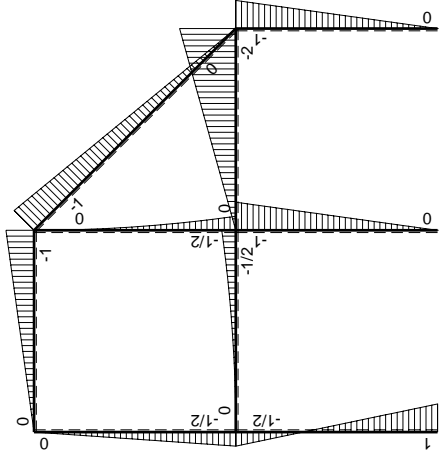
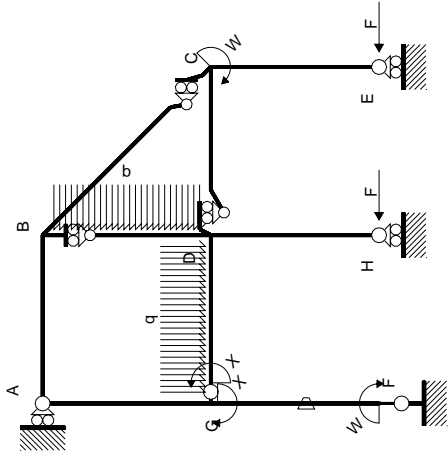

Schema di calcolo iperstatico

M_0 flessione da carichi assegnati

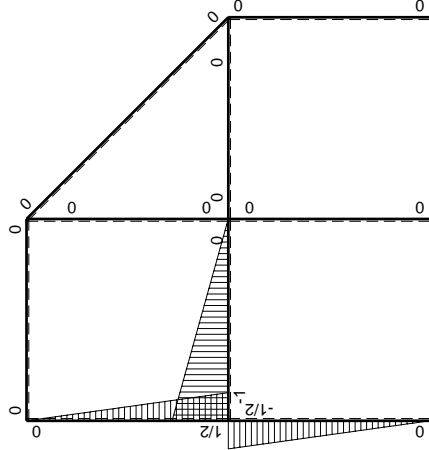

M_x flessione da iperstatica $X=1$

Quadro contributi PLV per iperstatica $X=W_{GD}$

→	$M_x(x)$	$M_o(x)$	θ	$M_x M_o$	$M_x \theta$	$M_x M_x$	$\int M_x(M_o/EJ+\theta)dx$	$\int X M_x M_x/EJ dx$	
AB b	0	-Fx	0	0	0	0	0+0	0	
BA b	0	Fb-Fx	0	0	0	0			
BC $\sqrt{2}b$	0	-Fb+ $\sqrt{2}/2Fx$	0	0	0	0	0	0	
BD b	0	-1/2qx ²	0	0	0	0	0+0	0	
DB b	0	1/2Fb-Fx+1/2qx ²	0	0	0	0			
DC b	0	-2Fx	0	0	0	0	0+0	0	
CD b	0	2Fb-2Fx	0	0	0	0			
CE b	0	-Fb+Fx	0	0	0	0	0+0	0	
EC b	0	Fx	0	0	0	0			
FG b	-1/2x/b	Fb-3/2Fx	-Fb/EJ	-1/2Fx+3/4Fx ² /b	1/2Fx/EJ	1/4x ² /b ²	(0+1/4)Fb ² /EJ	1/12Xb/EJ	
GF b	1/2-1/2x/b	1/2Fb-3/2Fx	Fb/EJ	1/4Fb-Fx+3/4Fx ² /b	1/2Fb/EJ-1/2Fx/EJ	1/4-1/2x/b+1/4x ² /b ²			
GD b	-1+x/b	-1/2qx ²	0	1/2Fx ² /b-1/2qx ³ /b	0	1-2x/b+x ² /b ²	(1/24+0)Fb ² /EJ	1/3Xb/EJ	
DG b	x/b	1/2Fb-Fx+1/2qx ²	0	1/2Fx-Fx ² /b+1/2qx ³ /b	0	x ² /b ²			
DH b	0	-Fb+Fx	0	0	0	0	0+0	0	
HD b	0	Fx	0	0	0	0			
GA b	1/2-1/2x/b	-1/2Fb+1/2Fx	0	-1/4Fb+1/2Fx-1/4Fx ² /b	0	1/4-1/2x/b+1/4x ² /b ²	(-1/12+0)Fb ² /EJ	1/12Xb/EJ	
AG b	-1/2x/b	1/2Fx	0	-1/4Fx ² /b	0	1/4x ² /b ²			
	totali							5/24Fb ² /EJ	1/2Xb/EJ
	iperstatica $X=W_{GD}$							-5/12Fb	

Sviluppi di calcolo iperstatica

$$L_{FG}^{xx} = \int_0^b (1/4 x^2/b^2) 1/EJ dx = [1/12 x^3/b^2]_0^b 1/EJ$$

$$= (1/12 b) 1/EJ = 1/12 b/EJ$$

$$L_{GF}^{xx} = \int_0^b (1/4 - 1/2 x/b + 1/4 x^2/b^2) 1/EJ dx = [1/4 x - 1/4 x^2/b + 1/12 x^3/b^2]_0^b 1/EJ$$

$$= (1/4 b - 1/4 b + 1/12 b) 1/EJ = 1/12 b/EJ$$

$$L_{GD}^{xx} = \int_0^b (1 - 2 x/b + x^2/b^2) 1/EJ dx = [x - x^2/b + 1/3 x^3/b^2]_0^b 1/EJ$$

$$= (b - b + 1/3 b) 1/EJ = 1/3 b/EJ$$

$$L_{DG}^{xx} = \int_0^b (x^2/b^2) 1/EJ dx = [1/3 x^3/b^2]_0^b 1/EJ$$

$$= (1/3 b) 1/EJ = 1/3 b/EJ$$

$$L_{GA}^{xx} = \int_0^b (1/4 - 1/2 x/b + 1/4 x^2/b^2) 1/EJ dx = [1/4 x - 1/4 x^2/b + 1/12 x^3/b^2]_0^b 1/EJ$$

$$= (1/4 b - 1/4 b + 1/12 b) 1/EJ = 1/12 b/EJ$$

$$L_{AG}^{xx} = \int_0^b (1/4 x^2/b^2) 1/EJ dx = [1/12 x^3/b^2]_0^b 1/EJ$$

$$= (1/12 b) 1/EJ = 1/12 b/EJ$$

$$L_{FG}^{xo} = \int_0^b (-1/2 x/b + 3/4 x^2/b^2) Fb 1/EJ dx + \int_0^b (1/2 x/b) \theta dx$$

$$= [-1/4 x^2/b + 1/4 x^3/b^2]_0^b Fb 1/EJ + [1/4 x^2/b]_0^b \theta$$

$$= (-1/4 b + 1/4 b) Fb 1/EJ + (1/4 b) \theta = 1/4 Fb^2/EJ$$

$$L_{GF}^{xo} = \int_0^b (1/4 - x/b + 3/4 x^2/b^2) Fb 1/EJ dx + \int_0^b (-1/2 + 1/2 x/b) \theta dx$$

$$= [1/4 x - 1/2 x^2/b + 1/4 x^3/b^2]_0^b Fb 1/EJ + [-1/2 x + 1/4 x^2/b]_0^b \theta$$

$$= (1/4 b - 1/2 b + 1/4 b) Fb 1/EJ + (-1/2 b + 1/4 b) \theta = 1/4 Fb^2/EJ$$

$$L_{GD}^{xo} = \int_0^b (1/2 x^2/b^2 - 1/2 x^3/b^3) Fb 1/EJ dx = [1/6 x^3/b^2 - 1/8 x^4/b^3]_0^b Fb 1/EJ$$

$$= (1/6 b - 1/8 b) Fb 1/EJ = 1/24 Fb^2/EJ$$

$$L_{DG}^{xo} = \int_0^b (1/2 x/b - x^2/b^2 + 1/2 x^3/b^3) Fb 1/EJ dx = [1/4 x^2/b - 1/3 x^3/b^2 + 1/8 x^4/b^3]_0^b Fb 1/EJ$$

$$= (1/4 b - 1/3 b + 1/8 b) Fb 1/EJ = 1/24 Fb^2/EJ$$

$$L_{GA}^{xo} = \int_0^b (-1/4 + 1/2 x/b - 1/4 x^2/b^2) Fb 1/EJ dx = [-1/4 x + 1/4 x^2/b - 1/12 x^3/b^2]_0^b Fb 1/EJ$$

$$= (-1/4 b + 1/4 b - 1/12 b) Fb 1/EJ = -1/12 Fb^2/EJ$$

$$L_{AG}^{xo} = \int_0^b (-1/4 x^2/b^2) Fb 1/EJ dx = [-1/12 x^3/b^2]_0^b Fb 1/EJ$$

$$= (-1/12 b) Fb 1/EJ = -1/12 Fb^2/EJ$$

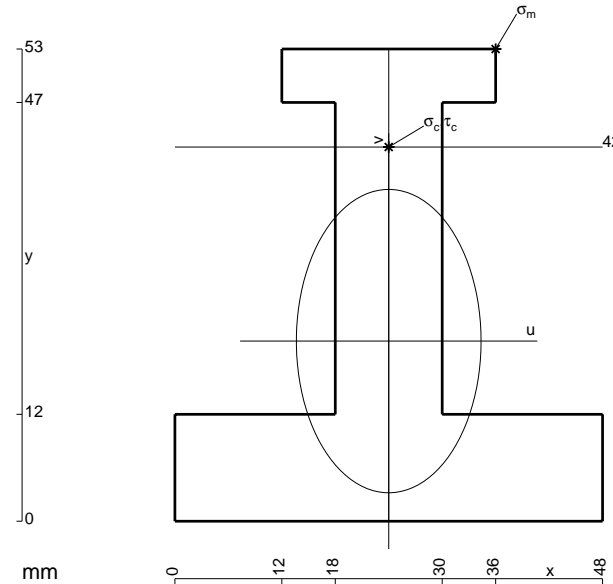

- A = 1140. mm²
- J_u = 330567. mm⁴
- J_v = 122544. mm⁴
- y_g = 20.22 mm
- T_y = -2540. N
- M_x = -2413000. Nmm
- x_m = 36. mm
- y_m = 53. mm
- u_m = 12. mm
- v_m = 32.78 mm
- σ_m = -Mv/J_u = 239.3 N/mm²
- x_c = 24. mm
- y_c = 42. mm
- v_c = 21.78 mm
- σ_c = -Mv/J_u = 159. N/mm²
- τ_c = 3.679 N/mm²
- σ_o = √σ²+3τ² = 159.1 N/mm²
- S = 5746. mm³

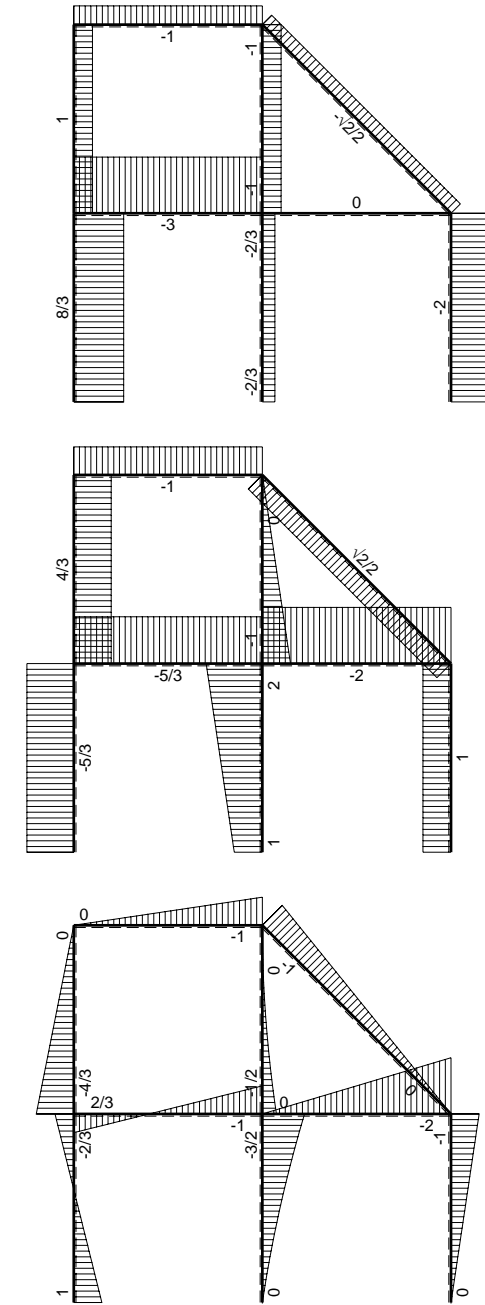
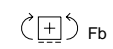
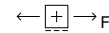
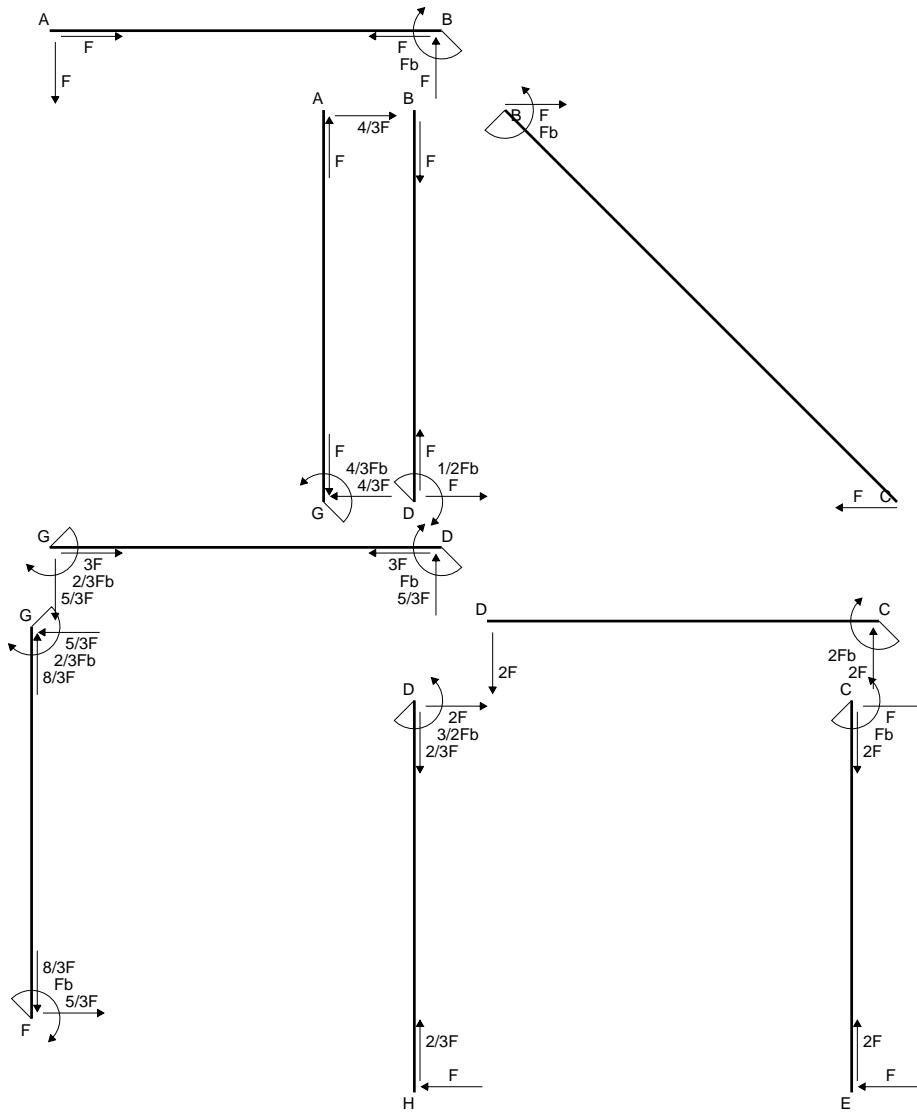

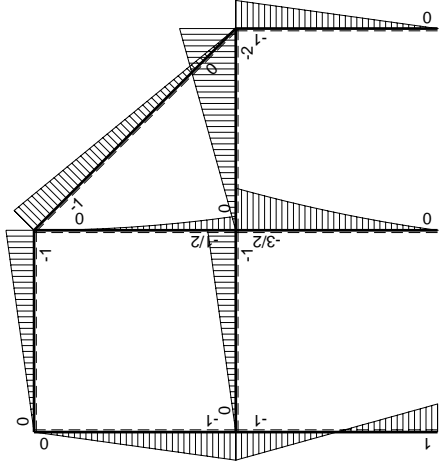
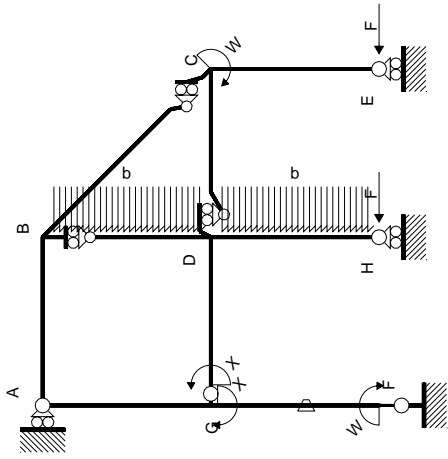

Schema di calcolo iperstatico

M_0 flessione da carichi assegnati

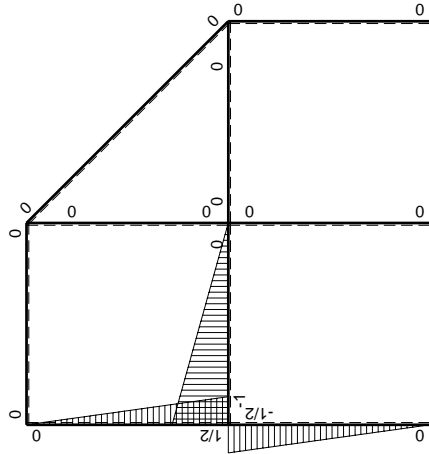

M_x flessione da iperstatica $X=1$

Quadro contributi PLV per iperstatica $X=W_{GD}$

→	$M_x(x)$	$M_o(x)$	θ	$M_x M_o$	$M_x \theta$	$M_x M_x$	$\int M_x(M_o/EJ+\theta)dx$	$\int X M_x M_x/EJ dx$	
AB b	0	-Fx	0	0	0	0	0+0	0	
BA b	0	Fb-Fx	0	0	0	0	0	0	
BC $\sqrt{2}b$	0	-Fb+ $\sqrt{2}/2Fx$	0	0	0	0	0	0	
BD b	0	-1/2qx ²	0	0	0	0	0+0	0	
DB b	0	1/2Fb-Fx+1/2qx ²	0	0	0	0	0	0	
DC b	0	-2Fx	0	0	0	0	0+0	0	
CD b	0	2Fb-2Fx	0	0	0	0	0	0	
CE b	0	-Fb+Fx	0	0	0	0	0+0	0	
EC b	0	Fx	0	0	0	0	0	0	
FG b	-1/2x/b	Fb-2Fx	-Fb/EJ	-1/2Fx+Fx ² /b	1/2Fx/EJ	1/4x ² /b ²	(1/12+1/4)Fb ² /EJ	1/12Xb/EJ	
GF b	1/2-1/2x/b	Fb-2Fx	Fb/EJ	1/2Fb-3/2Fx+Fx ² /b	1/2Fb/EJ-1/2Fx/EJ	1/4-1/2x/b+1/4x ² /b ²			
GD b	-1+x/b	-Fx	0	Fx-Fx ² /b	0	1-2x/b+x ² /b ²	(1/6+0)Fb ² /EJ	1/3Xb/EJ	
DG b	x/b	Fb-Fx	0	Fx-Fx ² /b	0	x ² /b ²			
DH b	0	-3/2Fb+2Fx-1/2qx ²	0	0	0	0	0+0	0	
HD b	0	Fx+1/2qx ²	0	0	0	0	0	0	
GA b	1/2-1/2x/b	-Fb+Fx	0	-1/2Fb+Fx-1/2Fx ² /b	0	1/4-1/2x/b+1/4x ² /b ²	(-1/6+0)Fb ² /EJ	1/12Xb/EJ	
AG b	-1/2x/b	Fx	0	-1/2Fx ² /b	0	1/4x ² /b ²			
	totali							1/3Fb ² /EJ	1/2Xb/EJ
	iperstatica $X=W_{GD}$							-2/3Fb	

Sviluppi di calcolo iperstatica

$$L_{FG}^{xx} = \int_0^b (1/4 x^2/b^2) 1/EJ dx = [1/12 x^3/b^2]_0^b 1/EJ$$

$$= (1/12 b) 1/EJ = 1/12 b/EJ$$

$$L_{GF}^{xx} = \int_0^b (1/4 - 1/2 x/b + 1/4 x^2/b^2) 1/EJ dx = [1/4 x - 1/4 x^2/b + 1/12 x^3/b^2]_0^b 1/EJ$$

$$= (1/4 b - 1/4 b + 1/12 b) 1/EJ = 1/12 b/EJ$$

$$L_{GD}^{xx} = \int_0^b (1 - 2 x/b + x^2/b^2) 1/EJ dx = [x - x^2/b + 1/3 x^3/b^2]_0^b 1/EJ$$

$$= (b - b + 1/3 b) 1/EJ = 1/3 b/EJ$$

$$L_{DG}^{xx} = \int_0^b (x^2/b^2) 1/EJ dx = [1/3 x^3/b^2]_0^b 1/EJ$$

$$= (1/3 b) 1/EJ = 1/3 b/EJ$$

$$L_{GA}^{xx} = \int_0^b (1/4 - 1/2 x/b + 1/4 x^2/b^2) 1/EJ dx = [1/4 x - 1/4 x^2/b + 1/12 x^3/b^2]_0^b 1/EJ$$

$$= (1/4 b - 1/4 b + 1/12 b) 1/EJ = 1/12 b/EJ$$

$$L_{AG}^{xx} = \int_0^b (1/4 x^2/b^2) 1/EJ dx = [1/12 x^3/b^2]_0^b 1/EJ$$

$$= (1/12 b) 1/EJ = 1/12 b/EJ$$

$$L_{FG}^{xo} = \int_0^b (-1/2 x/b + x^2/b^2) Fb 1/EJ dx + \int_0^b (1/2 x/b) \theta dx$$

$$= [-1/4 x^2/b + 1/3 x^3/b^2]_0^b Fb 1/EJ + [1/4 x^2/b]_0^b \theta$$

$$= (-1/4 b + 1/3 b) Fb 1/EJ + (1/4 b) \theta = 1/3 Fb^2/EJ$$

$$L_{GF}^{xo} = \int_0^b (1/2 - 3/2 x/b + x^2/b^2) Fb 1/EJ dx + \int_0^b (-1/2 + 1/2 x/b) \theta dx$$

$$= [1/2 x - 3/4 x^2/b + 1/3 x^3/b^2]_0^b Fb 1/EJ + [-1/2 x + 1/4 x^2/b]_0^b \theta$$

$$= (1/2 b - 3/4 b + 1/3 b) Fb 1/EJ + (-1/2 b + 1/4 b) \theta = 1/3 Fb^2/EJ$$

$$L_{GD}^{xo} = \int_0^b (x/b - x^2/b^2) Fb 1/EJ dx = [1/2 x^2/b - 1/3 x^3/b^2]_0^b Fb 1/EJ$$

$$= (1/2 b - 1/3 b) Fb 1/EJ = 1/6 Fb^2/EJ$$

$$L_{DG}^{xo} = \int_0^b (x/b - x^2/b^2) Fb 1/EJ dx = [1/2 x^2/b - 1/3 x^3/b^2]_0^b Fb 1/EJ$$

$$= (1/2 b - 1/3 b) Fb 1/EJ = 1/6 Fb^2/EJ$$

$$L_{GA}^{xo} = \int_0^b (-1/2 + x/b - 1/2 x^2/b^2) Fb 1/EJ dx = [-1/2 x + 1/2 x^2/b - 1/6 x^3/b^2]_0^b Fb 1/EJ$$

$$= (-1/2 b + 1/2 b - 1/6 b) Fb 1/EJ = -1/6 Fb^2/EJ$$

$$L_{AG}^{xo} = \int_0^b (-1/2 x^2/b^2) Fb 1/EJ dx = [-1/6 x^3/b^2]_0^b Fb 1/EJ$$

$$= (-1/6 b) Fb 1/EJ = -1/6 Fb^2/EJ$$

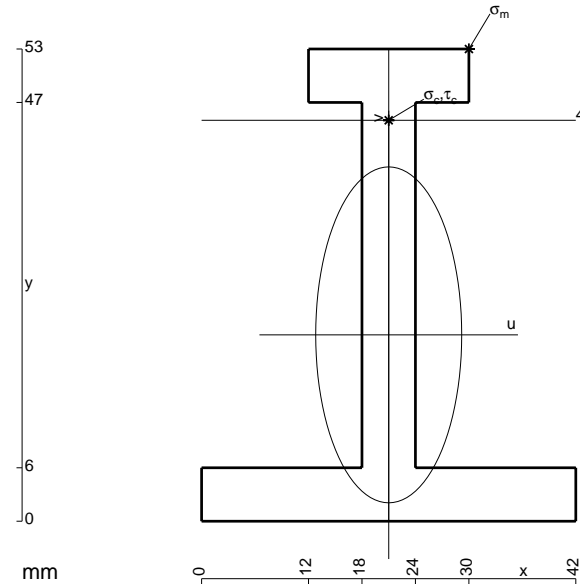

- A = 606. mm²
- J_u = 215454. mm⁴
- J_v = 40698. mm⁴
- y_g = 20.92 mm
- T_y = -2680. N
- M_x = -1340000. Nmm
- x_m = 30. mm
- y_m = 53. mm
- u_m = 9. mm
- v_m = 32.08 mm
- σ_m = -Mv/J_u = 199.5 N/mm²
- x_c = 21. mm
- y_c = 45. mm
- v_c = 24.08 mm
- σ_c = -Mv/J_u = 149.8 N/mm²
- τ_c = 7.136 N/mm²
- σ_o = √σ²+3τ² = 150.3 N/mm²
- S = 3442. mm³

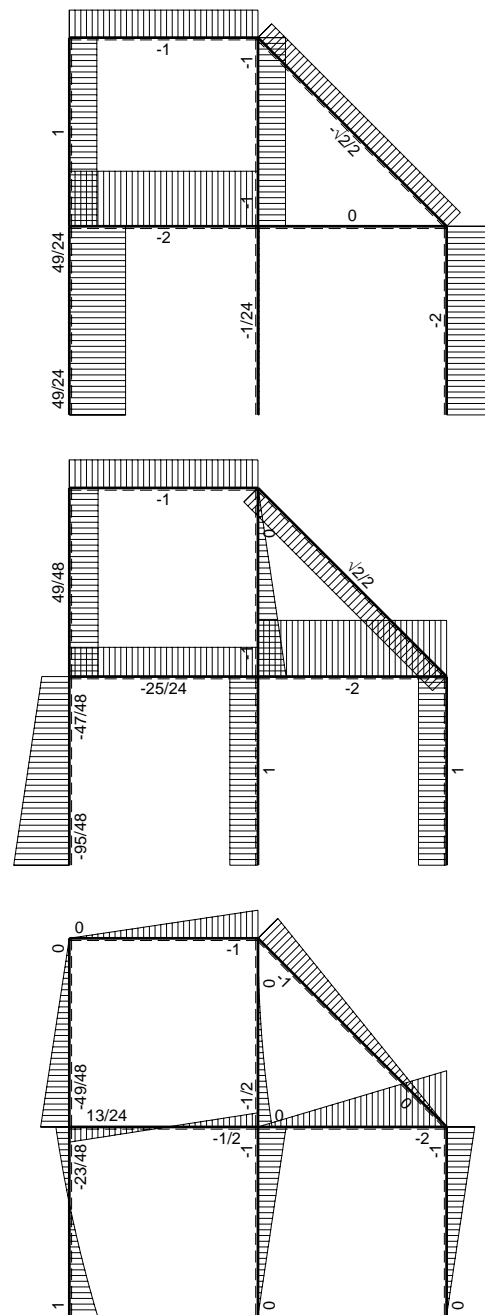
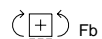
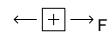
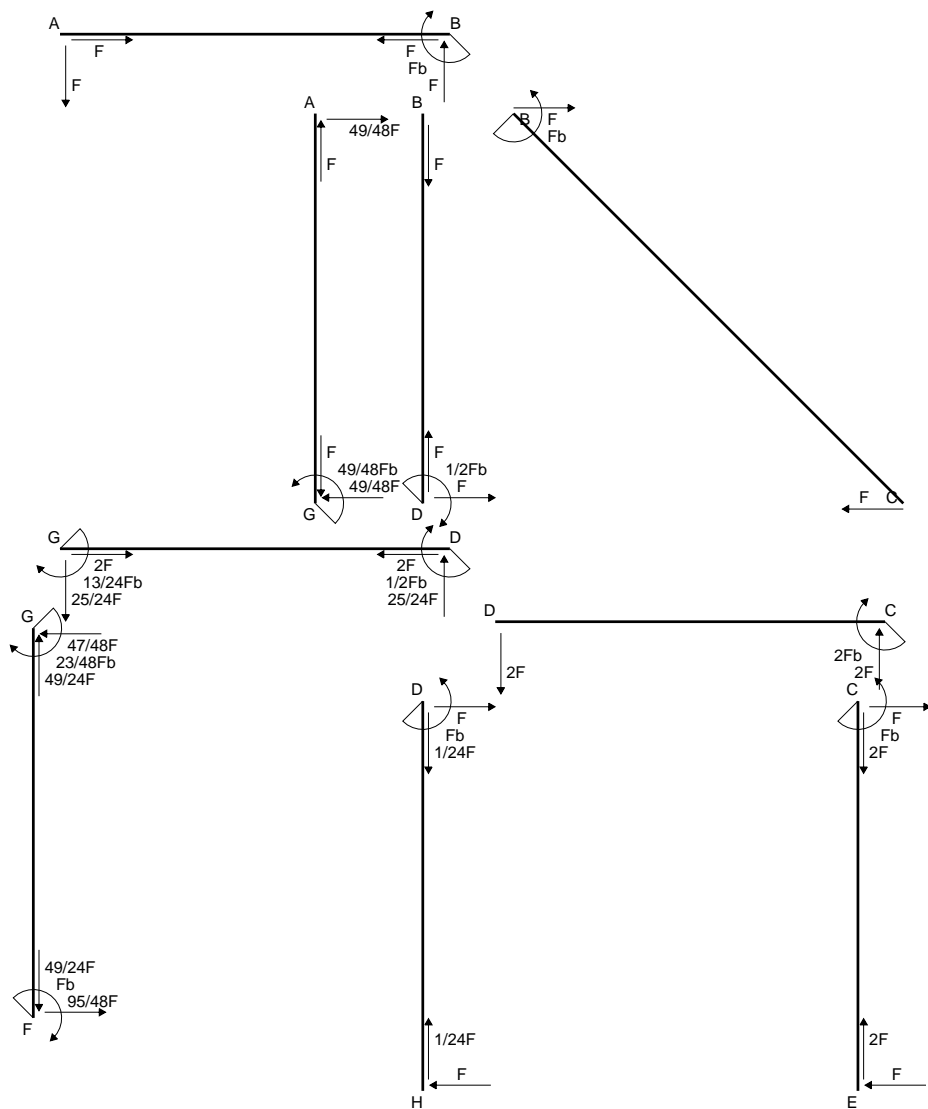

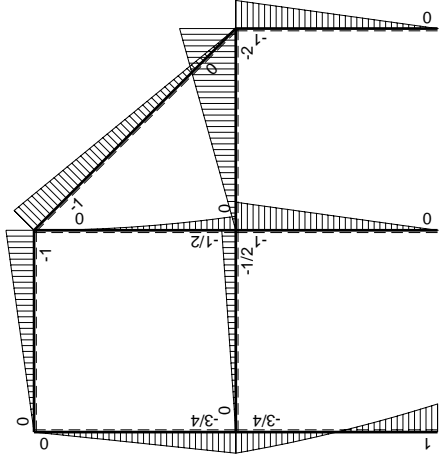
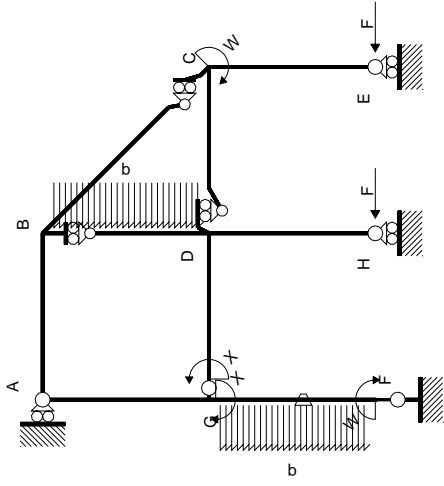

Schema di calcolo iperstatico

M_0 flessione da carichi assegnati

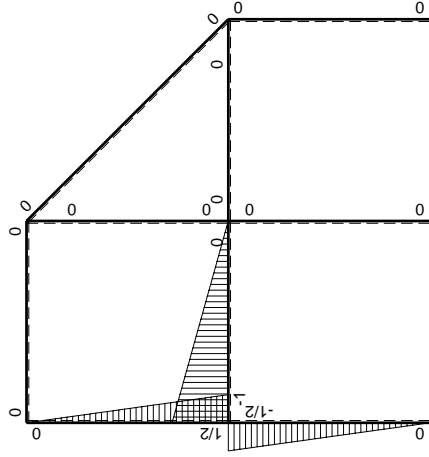

M_x flessione da iperstatica $X=1$

Quadro contributi PLV per iperstatica $X=W_{GD}$

→	$M_x(x)$	$M_o(x)$	θ	$M_x M_o$	$M_x \theta$	$M_x M_x$	$\int M_x(M_o/EJ+\theta)dx$	$\int X M_x M_x / EJ dx$
AB b	0	-Fx	0	0	0	0	0+0	0
BA b	0	Fb-Fx	0	0	0	0	0	0
BC $\sqrt{2}b$	0	-Fb+ $\sqrt{2}/2Fx$	0	0	0	0	0	0
BD b	0	-1/2qx ²	0	0	0	0	0+0	0
DB b	0	1/2Fb-Fx+1/2qx ²	0	0	0	0	0	0
DC b	0	-2Fx	0	0	0	0	0+0	0
CD b	0	2Fb-2Fx	0	0	0	0	0	0
CE b	0	-Fb+Fx	0	0	0	0	0+0	0
EC b	0	Fx	0	0	0	0	0	0
FG b	-1/2x/b	Fb-9/4Fx+1/2qx ²	-Fb/EJ	-1/2Fx+9/8Fx ² /b-1/4qx ³ /b	1/2Fx/EJ	1/4x ² /b ²	(1/16+1/4)Fb ² /EJ	1/12Xb/EJ
GF b	1/2-1/2x/b	3/4Fb-5/4Fx-1/2qx ²	Fb/EJ	3/8Fb-Fx+3/8Fx ² /b+1/4qx ³ /b	1/2Fb/EJ-1/2Fx/EJ	1/4-1/2x/b+1/4x ² /b ²		
GD b	-1+x/b	-1/2Fx	0	1/2Fx-1/2Fx ² /b	0	1-2x/b+x ² /b ²	(1/12+0)Fb ² /EJ	1/3Xb/EJ
DG b	x/b	1/2Fb-1/2Fx	0	1/2Fx-1/2Fx ² /b	0	x ² /b ²		
DH b	0	-Fb+Fx	0	0	0	0	0+0	0
HD b	0	Fx	0	0	0	0	0	0
GA b	1/2-1/2x/b	-3/4Fb+3/4Fx	0	-3/8Fb+3/4Fx-3/8Fx ² /b	0	1/4-1/2x/b+1/4x ² /b ²	(-1/8+0)Fb ² /EJ	1/12Xb/EJ
AG b	-1/2x/b	3/4Fx	0	-3/8Fx ² /b	0	1/4x ² /b ²		
	totali						13/48Fb ² /EJ	1/2Xb/EJ
	iperstatica $X=W_{GD}$						-13/24Fb	

Sviluppi di calcolo iperstatica

$$L_{FG}^{xx} = \int_0^b (1/4 x^2/b^2) 1/EJ dx = [1/12 x^3/b^2]_0^b 1/EJ$$

$$= (1/12 b) 1/EJ = 1/12 b/EJ$$

$$L_{GF}^{xx} = \int_0^b (1/4 - 1/2 x/b + 1/4 x^2/b^2) 1/EJ dx = [1/4 x - 1/4 x^2/b + 1/12 x^3/b^2]_0^b 1/EJ$$

$$= (1/4 b - 1/4 b + 1/12 b) 1/EJ = 1/12 b/EJ$$

$$L_{GD}^{xx} = \int_0^b (1 - 2 x/b + x^2/b^2) 1/EJ dx = [x - x^2/b + 1/3 x^3/b^2]_0^b 1/EJ$$

$$= (b - b + 1/3 b) 1/EJ = 1/3 b/EJ$$

$$L_{DG}^{xx} = \int_0^b (x^2/b^2) 1/EJ dx = [1/3 x^3/b^2]_0^b 1/EJ$$

$$= (1/3 b) 1/EJ = 1/3 b/EJ$$

$$L_{GA}^{xx} = \int_0^b (1/4 - 1/2 x/b + 1/4 x^2/b^2) 1/EJ dx = [1/4 x - 1/4 x^2/b + 1/12 x^3/b^2]_0^b 1/EJ$$

$$= (1/4 b - 1/4 b + 1/12 b) 1/EJ = 1/12 b/EJ$$

$$L_{AG}^{xx} = \int_0^b (1/4 x^2/b^2) 1/EJ dx = [1/12 x^3/b^2]_0^b 1/EJ$$

$$= (1/12 b) 1/EJ = 1/12 b/EJ$$

$$L_{FG}^{xo} = \int_0^b (-1/2 x/b + 9/8 x^2/b^2 - 1/4 x^3/b^3) Fb 1/EJ dx + \int_0^b (1/2 x/b) \theta dx$$

$$= [-1/4 x^2/b + 3/8 x^3/b^2 - 1/16 x^4/b^3]_0^b Fb 1/EJ + [1/4 x^2/b]_0^b \theta$$

$$= (-1/4 b + 3/8 b - 1/16 b) Fb 1/EJ + (1/4 b) \theta = 5/16 Fb^2/EJ$$

$$L_{GF}^{xo} = \int_0^b (3/8 - x/b + 3/8 x^2/b^2 + 1/4 x^3/b^3) Fb 1/EJ dx + \int_0^b (-1/2 + 1/2 x/b) \theta dx$$

$$= [3/8 x - 1/2 x^2/b + 1/8 x^3/b^2 + 1/16 x^4/b^3]_0^b Fb 1/EJ + [-1/2 x + 1/4 x^2/b]_0^b \theta$$

$$= (3/8 b - 1/2 b + 1/8 b + 1/16 b) Fb 1/EJ + (-1/2 b + 1/4 b) \theta = 5/16 Fb^2/EJ$$

$$L_{GD}^{xo} = \int_0^b (1/2 x/b - 1/2 x^2/b^2) Fb 1/EJ dx = [1/4 x^2/b - 1/6 x^3/b^2]_0^b Fb 1/EJ$$

$$= (1/4 b - 1/6 b) Fb 1/EJ = 1/12 Fb^2/EJ$$

$$L_{DG}^{xo} = \int_0^b (1/2 x/b - 1/2 x^2/b^2) Fb 1/EJ dx = [1/4 x^2/b - 1/6 x^3/b^2]_0^b Fb 1/EJ$$

$$= (1/4 b - 1/6 b) Fb 1/EJ = 1/12 Fb^2/EJ$$

$$L_{GA}^{xo} = \int_0^b (-3/8 + 3/4 x/b - 3/8 x^2/b^2) Fb 1/EJ dx = [-3/8 x + 3/8 x^2/b - 1/8 x^3/b^2]_0^b Fb 1/EJ$$

$$= (-3/8 b + 3/8 b - 1/8 b) Fb 1/EJ = -1/8 Fb^2/EJ$$

$$L_{AG}^{xo} = \int_0^b (-3/8 x^2/b^2) Fb 1/EJ dx = [-1/8 x^3/b^2]_0^b Fb 1/EJ$$

$$= (-1/8 b) Fb 1/EJ = -1/8 Fb^2/EJ$$

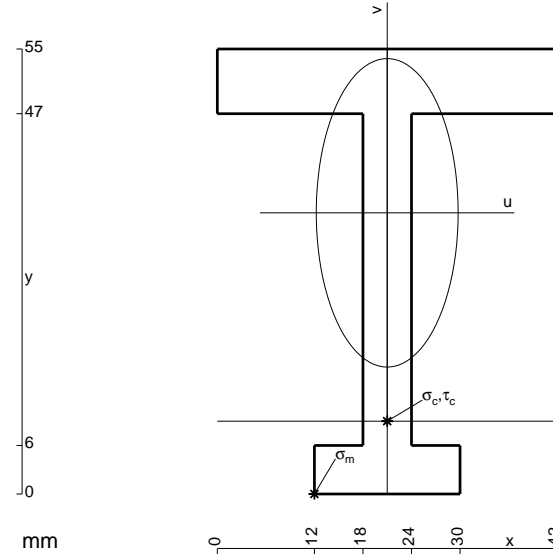

- A = 690. mm²
- J_u = 250916. mm⁴
- J_v = 53046. mm⁴
- y_g = 34.75 mm
- T_y = -2660. N
- M_x = -1516200. Nmm
- x_m = 12. mm
- u_m = -9. mm
- v_m = -34.75 mm
- σ_m = -Mv/J_u = -210. N/mm²
- x_c = 21. mm
- y_c = 9. mm
- v_c = -25.75 mm
- σ_c = -Mv/J_u = -155.6 N/mm²
- τ_c = 6.926 N/mm²
- σ_q = √σ²+3τ² = 156.1 N/mm²
- S = 3920. mm³

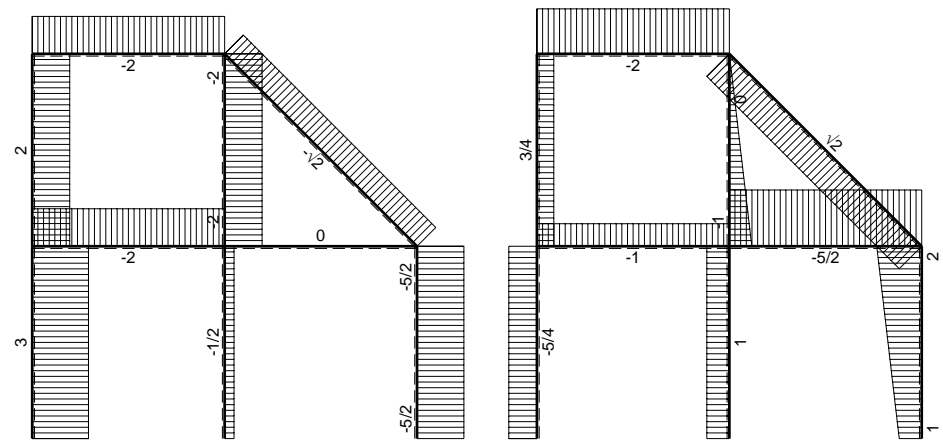
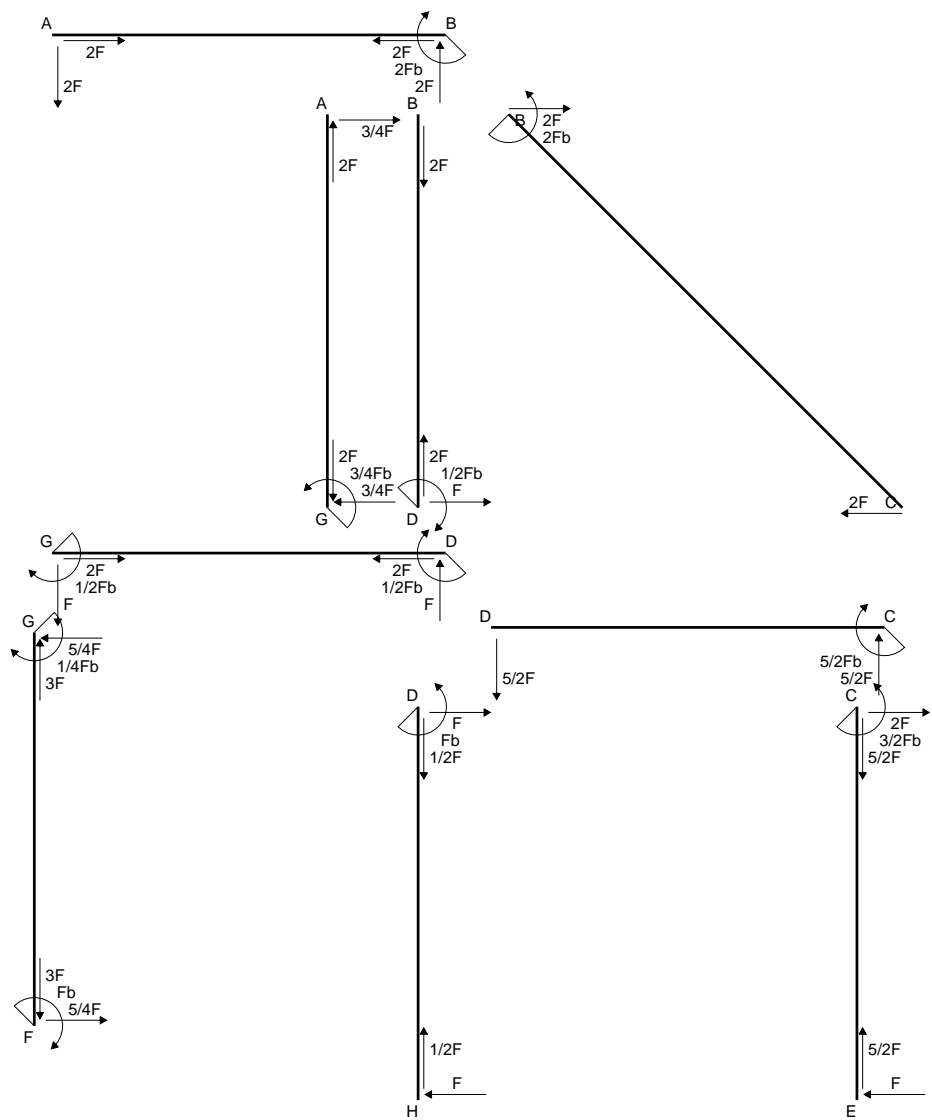

← ⊕ → F

↑ ⊕ ↓ F

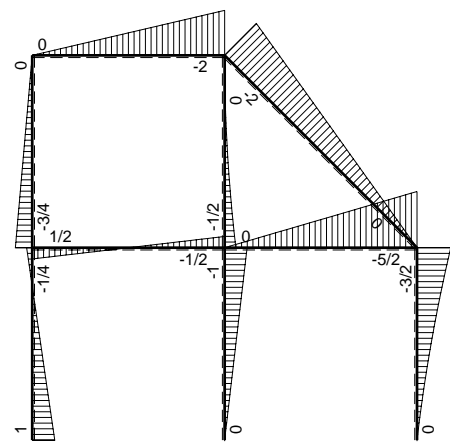

⊕ F_b

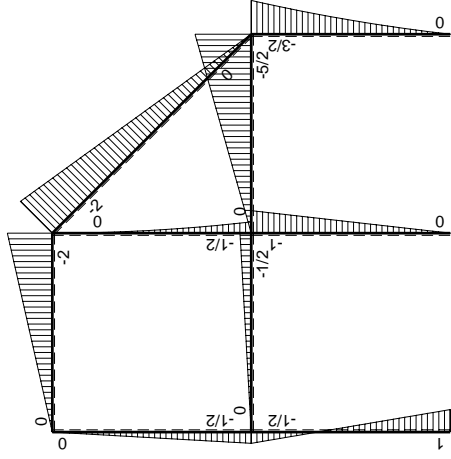
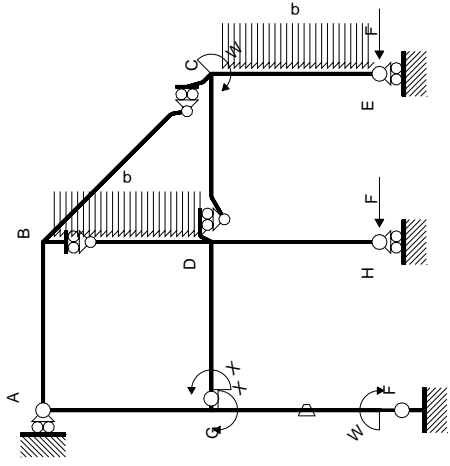

Schema di calcolo iperstatico

M_0 , flessione da carichi assegnati

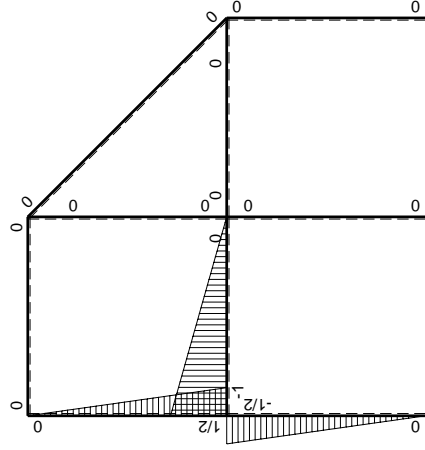

M_1 , flessione da iperstatica $X=1$

Quadro contributi PLV per iperstatica $X=W_{GD}$

→	$M_x(x)$	$M_o(x)$	θ	$M_x M_o$	$M_x \theta$	$M_x M_x$	$\int M_x(M_o/EJ+\theta)dx$	$\int X M_x M_x/EJ dx$
AB b	0	-2Fx	0	0	0	0	0+0	0
BA b	0	2Fb-2Fx	0	0	0	0	0	0
BC $\sqrt{2}b$	0	-2Fb+ $\sqrt{2}Fx$	0	0	0	0	0	0
BD b	0	-1/2qx ²	0	0	0	0	0+0	0
DB b	0	1/2Fb-Fx+1/2qx ²	0	0	0	0	0	0
DC b	0	-5/2Fx	0	0	0	0	0+0	0
CD b	0	5/2Fb-5/2Fx	0	0	0	0	0	0
CE b	0	-3/2Fb+2Fx-1/2qx ²	0	0	0	0	0+0	0
EC b	0	Fx+1/2qx ²	0	0	0	0	0	0
FG b	-1/2x/b	Fb-3/2Fx	-Fb/EJ	-1/2Fx+3/4Fx ² /b	1/2Fx/EJ	1/4x ² /b ²	(0+1/4)Fb ² /EJ	1/12Xb/EJ
GF b	1/2-1/2x/b	1/2Fb-3/2Fx	Fb/EJ	1/4Fb-Fx+3/4Fx ² /b	1/2Fb/EJ-1/2Fx/EJ	1/4-1/2x/b+1/4x ² /b ²		
GD b	-1+x/b	-1/2Fx	0	1/2Fx-1/2Fx ² /b	0	1-2x/b+x ² /b ²	(1/12+0)Fb ² /EJ	1/3Xb/EJ
DG b	x/b	1/2Fb-1/2Fx	0	1/2Fx-1/2Fx ² /b	0	x ² /b ²		
DH b	0	-Fb+Fx	0	0	0	0	0+0	0
HD b	0	Fx	0	0	0	0	0	0
GA b	1/2-1/2x/b	-1/2Fb+1/2Fx	0	-1/4Fb+1/2Fx-1/4Fx ² /b	0	1/4-1/2x/b+1/4x ² /b ²	(-1/12+0)Fb ² /EJ	1/12Xb/EJ
AG b	-1/2x/b	1/2Fx	0	-1/4Fx ² /b	0	1/4x ² /b ²		
	totali						1/4Fb ² /EJ	1/2Xb/EJ
	iperstatica $X=W_{GD}$						-1/2Fb	

Sviluppi di calcolo iperstatica

$$L_{FG}^{xx} = \int_0^b (1/4 x^2/b^2) 1/EJ dx = [1/12 x^3/b^2]_0^b 1/EJ$$

$$= (1/12 b) 1/EJ = 1/12 b/EJ$$

$$L_{GF}^{xx} = \int_0^b (1/4 - 1/2 x/b + 1/4 x^2/b^2) 1/EJ dx = [1/4 x - 1/4 x^2/b + 1/12 x^3/b^2]_0^b 1/EJ$$

$$= (1/4 b - 1/4 b + 1/12 b) 1/EJ = 1/12 b/EJ$$

$$L_{GD}^{xx} = \int_0^b (1 - 2 x/b + x^2/b^2) 1/EJ dx = [x - x^2/b + 1/3 x^3/b^2]_0^b 1/EJ$$

$$= (b - b + 1/3 b) 1/EJ = 1/3 b/EJ$$

$$L_{DG}^{xx} = \int_0^b (x^2/b^2) 1/EJ dx = [1/3 x^3/b^2]_0^b 1/EJ$$

$$= (1/3 b) 1/EJ = 1/3 b/EJ$$

$$L_{GA}^{xx} = \int_0^b (1/4 - 1/2 x/b + 1/4 x^2/b^2) 1/EJ dx = [1/4 x - 1/4 x^2/b + 1/12 x^3/b^2]_0^b 1/EJ$$

$$= (1/4 b - 1/4 b + 1/12 b) 1/EJ = 1/12 b/EJ$$

$$L_{AG}^{xx} = \int_0^b (1/4 x^2/b^2) 1/EJ dx = [1/12 x^3/b^2]_0^b 1/EJ$$

$$= (1/12 b) 1/EJ = 1/12 b/EJ$$

$$L_{FG}^{xo} = \int_0^b (-1/2 x/b + 3/4 x^2/b^2) Fb 1/EJ dx + \int_0^b (1/2 x/b) \theta dx$$

$$= [-1/4 x^2/b + 1/4 x^3/b^2]_0^b Fb 1/EJ + [1/4 x^2/b]_0^b \theta$$

$$= (-1/4 b + 1/4 b) Fb 1/EJ + (1/4 b) \theta = 1/4 Fb^2/EJ$$

$$L_{GF}^{xo} = \int_0^b (1/4 - x/b + 3/4 x^2/b^2) Fb 1/EJ dx + \int_0^b (-1/2 + 1/2 x/b) \theta dx$$

$$= [1/4 x - 1/2 x^2/b + 1/4 x^3/b^2]_0^b Fb 1/EJ + [-1/2 x + 1/4 x^2/b]_0^b \theta$$

$$= (1/4 b - 1/2 b + 1/4 b) Fb 1/EJ + (-1/2 b + 1/4 b) \theta = 1/4 Fb^2/EJ$$

$$L_{GD}^{xo} = \int_0^b (1/2 x/b - 1/2 x^2/b^2) Fb 1/EJ dx = [1/4 x^2/b - 1/6 x^3/b^2]_0^b Fb 1/EJ$$

$$= (1/4 b - 1/6 b) Fb 1/EJ = 1/12 Fb^2/EJ$$

$$L_{DG}^{xo} = \int_0^b (1/2 x/b - 1/2 x^2/b^2) Fb 1/EJ dx = [1/4 x^2/b - 1/6 x^3/b^2]_0^b Fb 1/EJ$$

$$= (1/4 b - 1/6 b) Fb 1/EJ = 1/12 Fb^2/EJ$$

$$L_{GA}^{xo} = \int_0^b (-1/4 + 1/2 x/b - 1/4 x^2/b^2) Fb 1/EJ dx = [-1/4 x + 1/4 x^2/b - 1/12 x^3/b^2]_0^b Fb 1/EJ$$

$$= (-1/4 b + 1/4 b - 1/12 b) Fb 1/EJ = -1/12 Fb^2/EJ$$

$$L_{AG}^{xo} = \int_0^b (-1/4 x^2/b^2) Fb 1/EJ dx = [-1/12 x^3/b^2]_0^b Fb 1/EJ$$

$$= (-1/12 b) Fb 1/EJ = -1/12 Fb^2/EJ$$

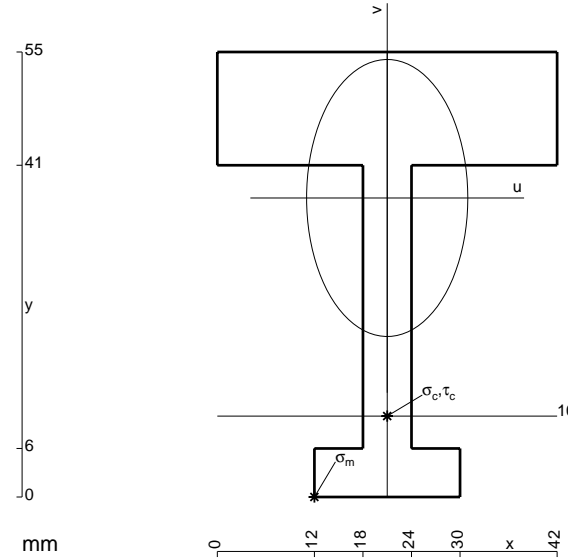

- A = 906. mm²
- J_u = 265632. mm⁴
- J_v = 89982. mm⁴
- y_g = 36.96 mm
- T_y = -2550. N
- M_x = -1581000. Nmm
- x_m = 12. mm
- u_m = -9. mm
- v_m = -36.96 mm
- σ_m = -Mv/J_u = -220. N/mm²
- x_c = 21. mm
- y_c = 10. mm
- v_c = -26.96 mm
- σ_c = -Mv/J_u = -160.4 N/mm²
- τ_c = 6.98 N/mm²
- σ_q = √σ²+3τ² = 160.9 N/mm²
- S = 4362. mm³

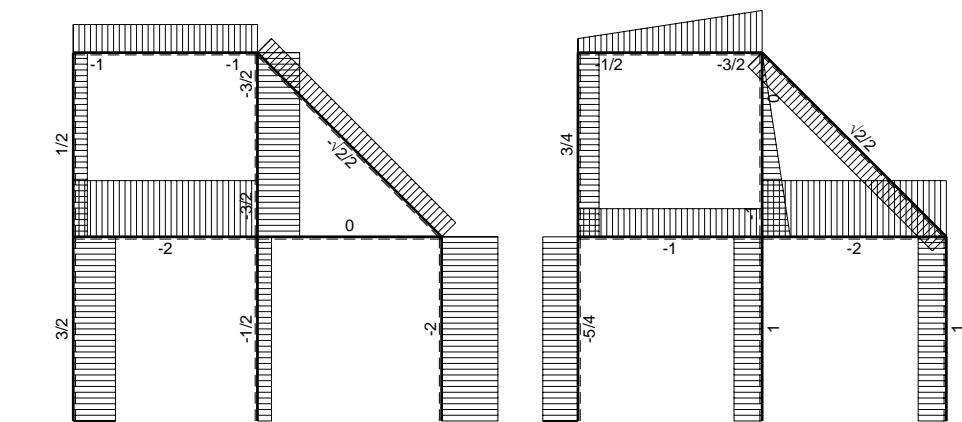
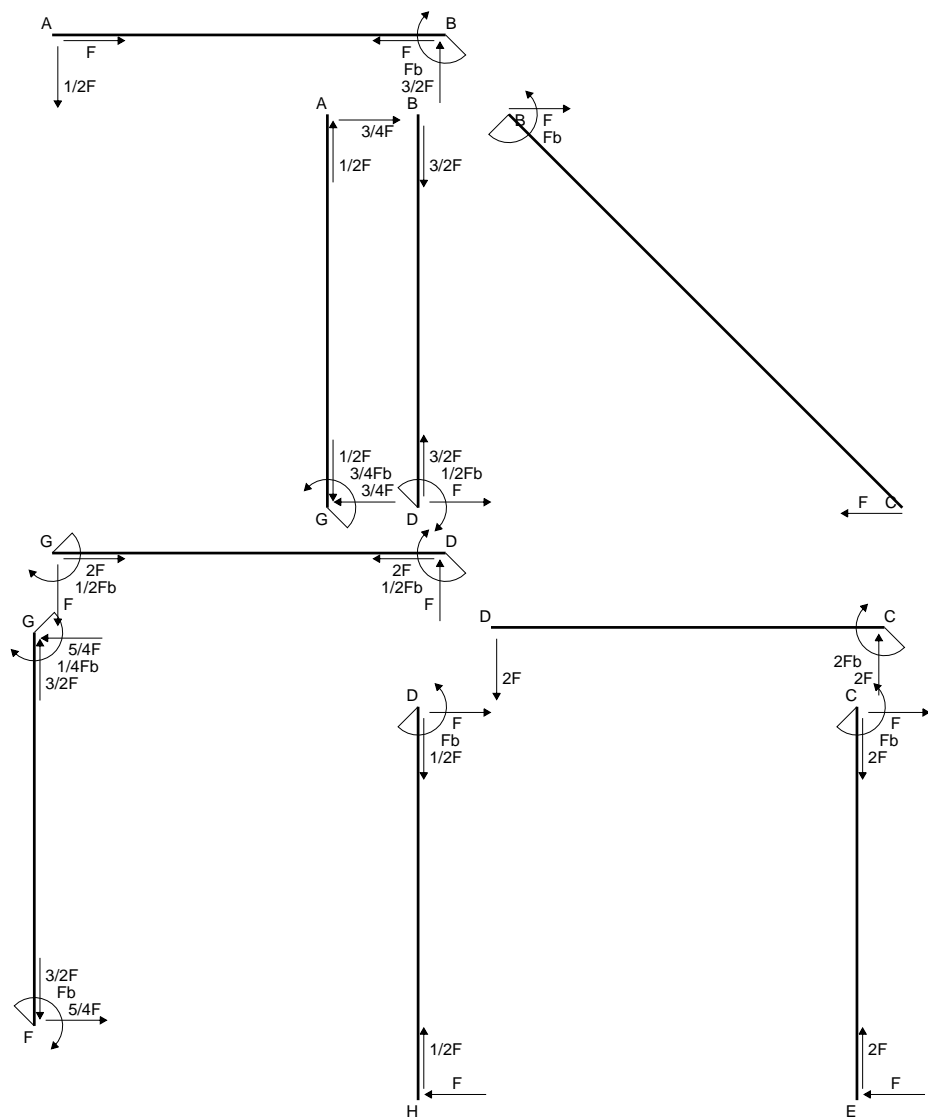

← ⊕ → F

↑ ⊕ ↓ F

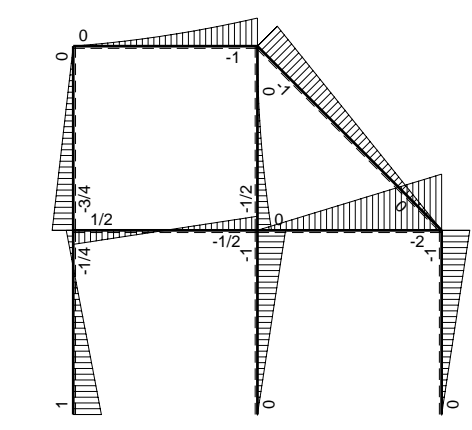

⊕ Fb

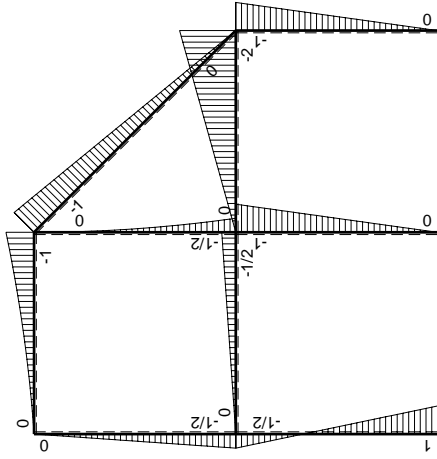
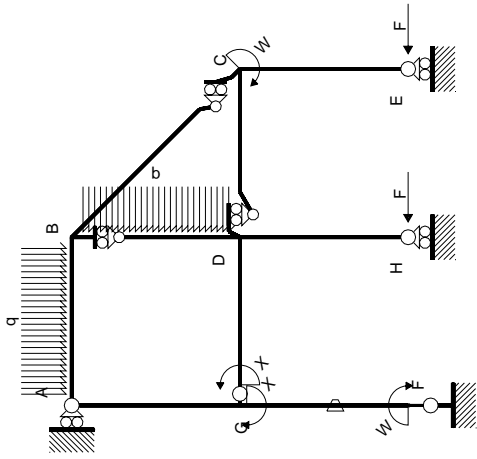

Schema di calcolo iperstatico

M_0 flessione da carichi assegnati

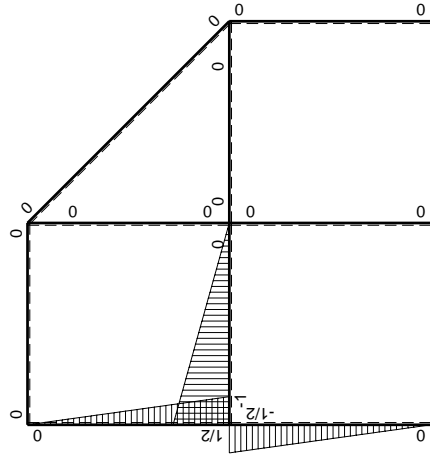

M_x flessione da iperstatica $X=1$

Quadro contributi PLV per iperstatica $X=W_{GD}$

→	$M_x(x)$	$M_o(x)$	θ	$M_x M_o$	$M_x \theta$	$M_x M_x$	$\int M_x(M_o/EJ+\theta)dx$	$\int X M_x M_x/EJdx$
AB b	0	$-1/2Fx-1/2qx^2$	0	0	0	0	0+0	0
BA b	0	$Fb-3/2Fx+1/2qx^2$	0	0	0	0		
BC $\sqrt{2}b$	0	$-Fb+\sqrt{2}/2Fx$	0	0	0	0	0	0
BD b	0	$-1/2qx^2$	0	0	0	0	0+0	0
DB b	0	$1/2Fb-Fx+1/2qx^2$	0	0	0	0		
DC b	0	$-2Fx$	0	0	0	0	0+0	0
CD b	0	$2Fb-2Fx$	0	0	0	0		
CE b	0	$-Fb+Fx$	0	0	0	0	0+0	0
EC b	0	Fx	0	0	0	0		
FG b	$-1/2x/b$	$Fb-3/2Fx$	$-Fb/EJ$	$-1/2Fx+3/4Fx^2/b$	$1/2Fx/EJ$	$1/4x^2/b^2$	$(0+1/4)Fb^2/EJ$	$1/12Xb/EJ$
GF b	$1/2-1/2x/b$	$1/2Fb-3/2Fx$	Fb/EJ	$1/4Fb-Fx+3/4Fx^2/b$	$1/2Fb/EJ-1/2Fx/EJ$	$1/4-1/2x/b+1/4x^2/b^2$		
GD b	$-1+x/b$	$-1/2Fx$	0	$1/2Fx-1/2Fx^2/b$	0	$1-2x/b+x^2/b^2$	$(1/12+0)Fb^2/EJ$	$1/3Xb/EJ$
DG b	x/b	$1/2Fb-1/2Fx$	0	$1/2Fx-1/2Fx^2/b$	0	x^2/b^2		
DH b	0	$-Fb+Fx$	0	0	0	0	0+0	0
HD b	0	Fx	0	0	0	0		
GA b	$1/2-1/2x/b$	$-1/2Fb+1/2Fx$	0	$-1/4Fb+1/2Fx-1/4Fx^2/b$	0	$1/4-1/2x/b+1/4x^2/b^2$	$(-1/12+0)Fb^2/EJ$	$1/12Xb/EJ$
AG b	$-1/2x/b$	$1/2Fx$	0	$-1/4Fx^2/b$	0	$1/4x^2/b^2$		
	totali						$1/4Fb^2/EJ$	$1/2Xb/EJ$
	iperstatica $X=W_{GD}$						$-1/2Fb$	

Sviluppi di calcolo iperstatica

$$L_{FG}^{xx} = \int_0^b (1/4 x^2/b^2) 1/EJ dx = [1/12 x^3/b^2]_0^b 1/EJ$$

$$= (1/12 b) 1/EJ = 1/12 b/EJ$$

$$L_{GF}^{xx} = \int_0^b (1/4 - 1/2 x/b + 1/4 x^2/b^2) 1/EJ dx = [1/4 x - 1/4 x^2/b + 1/12 x^3/b^2]_0^b 1/EJ$$

$$= (1/4 b - 1/4 b + 1/12 b) 1/EJ = 1/12 b/EJ$$

$$L_{GD}^{xx} = \int_0^b (1 - 2 x/b + x^2/b^2) 1/EJ dx = [x - x^2/b + 1/3 x^3/b^2]_0^b 1/EJ$$

$$= (b - b + 1/3 b) 1/EJ = 1/3 b/EJ$$

$$L_{DG}^{xx} = \int_0^b (x^2/b^2) 1/EJ dx = [1/3 x^3/b^2]_0^b 1/EJ$$

$$= (1/3 b) 1/EJ = 1/3 b/EJ$$

$$L_{GA}^{xx} = \int_0^b (1/4 - 1/2 x/b + 1/4 x^2/b^2) 1/EJ dx = [1/4 x - 1/4 x^2/b + 1/12 x^3/b^2]_0^b 1/EJ$$

$$= (1/4 b - 1/4 b + 1/12 b) 1/EJ = 1/12 b/EJ$$

$$L_{AG}^{xx} = \int_0^b (1/4 x^2/b^2) 1/EJ dx = [1/12 x^3/b^2]_0^b 1/EJ$$

$$= (1/12 b) 1/EJ = 1/12 b/EJ$$

$$L_{FG}^{xo} = \int_0^b (-1/2 x/b + 3/4 x^2/b^2) Fb 1/EJ dx + \int_0^b (1/2 x/b) \theta dx$$

$$= [-1/4 x^2/b + 1/4 x^3/b^2]_0^b Fb 1/EJ + [1/4 x^2/b]_0^b \theta$$

$$= (-1/4 b + 1/4 b) Fb 1/EJ + (1/4 b) \theta = 1/4 Fb^2/EJ$$

$$L_{GF}^{xo} = \int_0^b (1/4 - x/b + 3/4 x^2/b^2) Fb 1/EJ dx + \int_0^b (-1/2 + 1/2 x/b) \theta dx$$

$$= [1/4 x - 1/2 x^2/b + 1/4 x^3/b^2]_0^b Fb 1/EJ + [-1/2 x + 1/4 x^2/b]_0^b \theta$$

$$= (1/4 b - 1/2 b + 1/4 b) Fb 1/EJ + (-1/2 b + 1/4 b) \theta = 1/4 Fb^2/EJ$$

$$L_{GD}^{xo} = \int_0^b (1/2 x/b - 1/2 x^2/b^2) Fb 1/EJ dx = [1/4 x^2/b - 1/6 x^3/b^2]_0^b Fb 1/EJ$$

$$= (1/4 b - 1/6 b) Fb 1/EJ = 1/12 Fb^2/EJ$$

$$L_{DG}^{xo} = \int_0^b (1/2 x/b - 1/2 x^2/b^2) Fb 1/EJ dx = [1/4 x^2/b - 1/6 x^3/b^2]_0^b Fb 1/EJ$$

$$= (1/4 b - 1/6 b) Fb 1/EJ = 1/12 Fb^2/EJ$$

$$L_{GA}^{xo} = \int_0^b (-1/4 + 1/2 x/b - 1/4 x^2/b^2) Fb 1/EJ dx = [-1/4 x + 1/4 x^2/b - 1/12 x^3/b^2]_0^b Fb 1/EJ$$

$$= (-1/4 b + 1/4 b - 1/12 b) Fb 1/EJ = -1/12 Fb^2/EJ$$

$$L_{AG}^{xo} = \int_0^b (-1/4 x^2/b^2) Fb 1/EJ dx = [-1/12 x^3/b^2]_0^b Fb 1/EJ$$

$$= (-1/12 b) Fb 1/EJ = -1/12 Fb^2/EJ$$

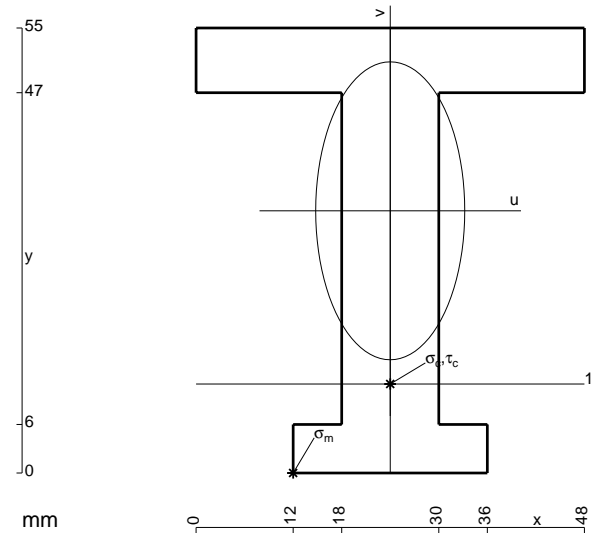

- A = 1020. mm²
- J_u = 345844. mm⁴
- J_v = 86544. mm⁴
- y_g = 32.41 mm
- T_y = -3660. N
- M_x = -2452200. Nmm
- x_m = 12. mm
- u_m = -12. mm
- v_m = -32.41 mm
- σ_m = -Mv/J_u = -229.8 N/mm²
- x_c = 24. mm
- y_c = 11. mm
- v_c = -21.41 mm
- σ_c = -Mv/J_u = -151.8 N/mm²
- τ_c = 4.999 N/mm²
- σ_o = √σ²+3τ² = 152. N/mm²
- S = 5669. mm³

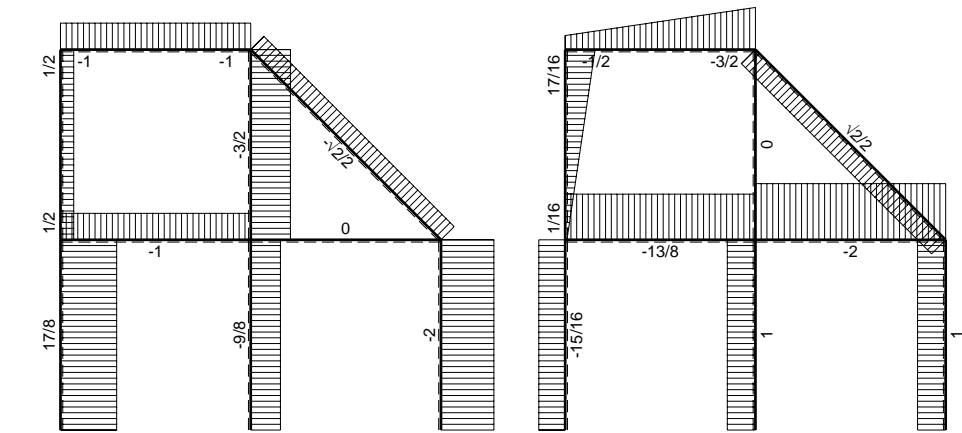
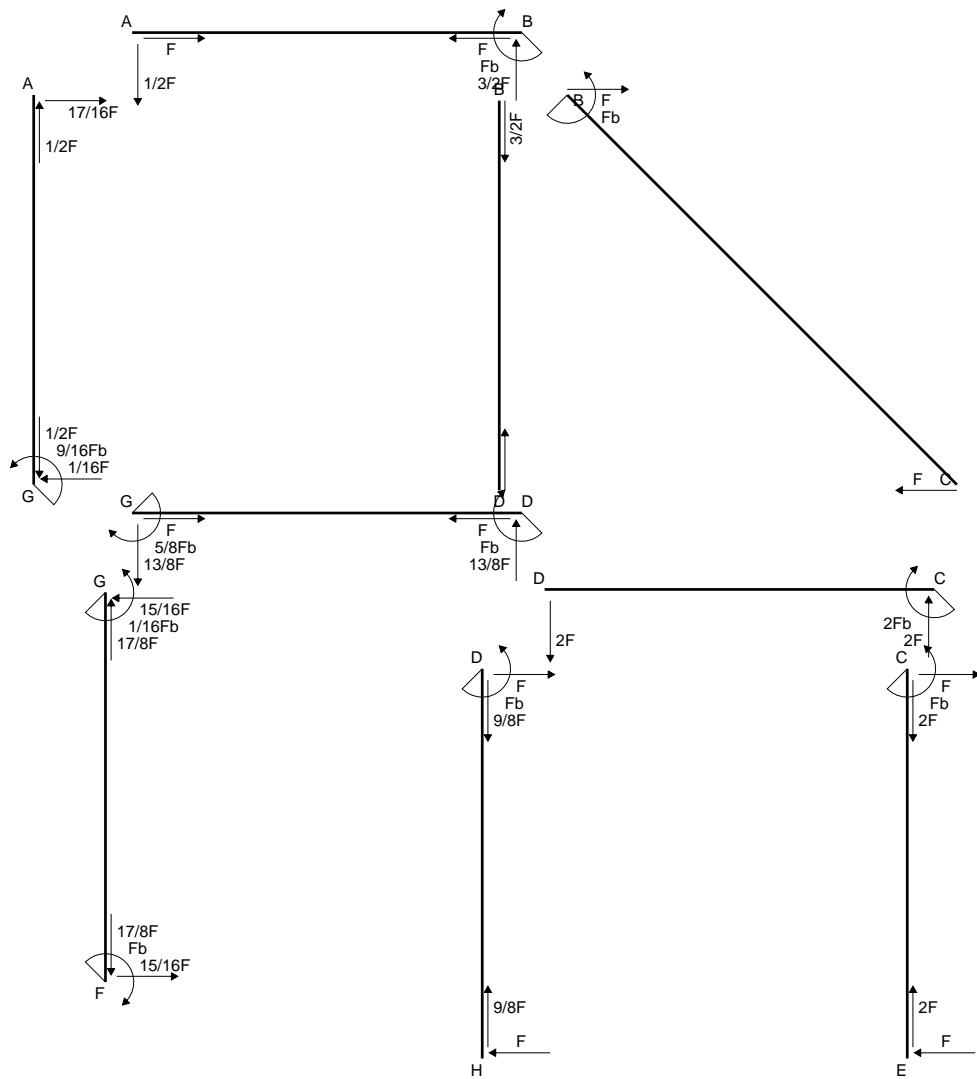

← ⊕ → F

↑ ⊕ ↓ F

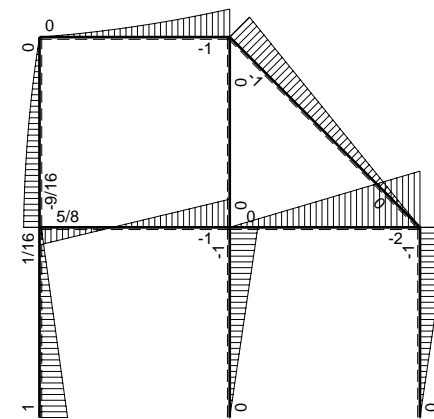

⊕ Fb

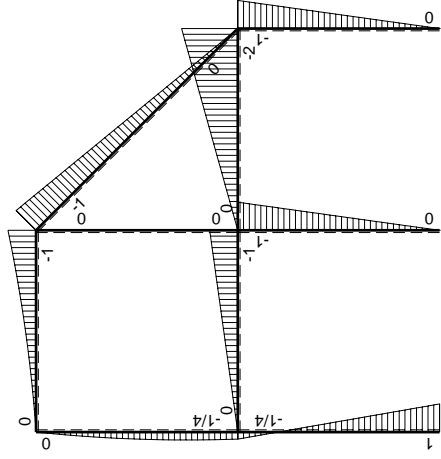
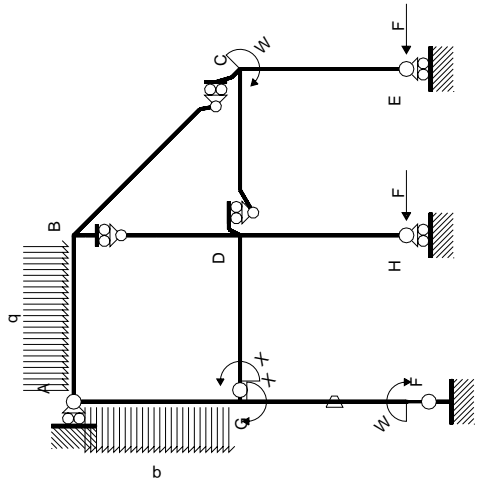

Schema di calcolo iperstatico

M_0 flessione da carichi assegnati

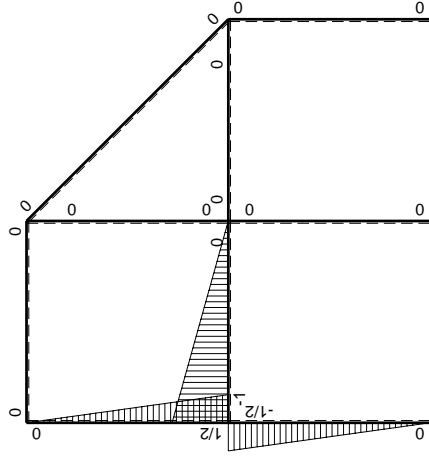

M_x flessione da iperstatica $X=1$

Quadro contributi PLV per iperstatica $X=W_{GD}$

→	$M_x(x)$	$M_o(x)$	θ	$M_x M_o$	$M_x \theta$	$M_x M_x$	$\int M_x(M_o/EJ+\theta)dx$	$\int X M_x M_x/EJ dx$	
AB b	0	$-1/2Fx-1/2qx^2$	0	0	0	0	0+0	0	
BA b	0	$Fb-3/2Fx+1/2qx^2$	0	0	0	0	0	0	
BC $\sqrt{2}b$	0	$-Fb+\sqrt{2}/2Fx$	0	0	0	0	0	0	
BD b	0	0	0	0	0	0	0+0	0	
DB b	0	0	0	0	0	0	0	0	
DC b	0	$-2Fx$	0	0	0	0	0+0	0	
CD b	0	$2Fb-2Fx$	0	0	0	0	0	0	
CE b	0	$-Fb+Fx$	0	0	0	0	0+0	0	
EC b	0	Fx	0	0	0	0	0	0	
FG b	$-1/2x/b$	$Fb-5/4Fx$	$-Fb/EJ$	$-1/2Fx+5/8Fx^2/b$	$1/2Fx/EJ$	$1/4x^2/b^2$	$(-1/24+1/4)Fb^2/EJ$	$1/12Xb/EJ$	
GF b	$1/2-1/2x/b$	$1/4Fb-5/4Fx$	Fb/EJ	$1/8Fb-3/4Fx+5/8Fx^2/b$	$1/2Fb/EJ-1/2Fx/EJ$	$1/4-1/2x/b+1/4x^2/b^2$			
GD b	$-1+x/b$	$-Fx$	0	$Fx-Fx^2/b$	0	$1-2x/b+x^2/b^2$	$(1/6+0)Fb^2/EJ$	$1/3Xb/EJ$	
DG b	x/b	$Fb-Fx$	0	$Fx-Fx^2/b$	0	x^2/b^2			
DH b	0	$-Fb+Fx$	0	0	0	0	0+0	0	
HD b	0	Fx	0	0	0	0	0	0	
GA b	$1/2-1/2x/b$	$-1/4Fb-1/4Fx+1/2qx^2$	0	$-1/8Fb+3/8Fx^2/b-1/4qx^3/b$	0	$1/4-1/2x/b+1/4x^2/b^2$	$(-1/16+0)Fb^2/EJ$	$1/12Xb/EJ$	
AG b	$-1/2x/b$	$3/4Fx-1/2qx^2$	0	$-3/8Fx^2/b+1/4qx^3/b$	0	$1/4x^2/b^2$			
	totali							$5/16Fb^2/EJ$	$1/2Xb/EJ$
	iperstatica $X=W_{GD}$							$-5/8Fb$	

Sviluppi di calcolo iperstatica

$$L_{FG}^{xx} = \int_0^b (1/4 x^2/b^2) 1/EJ dx = [1/12 x^3/b^2]_0^b 1/EJ$$

$$= (1/12 b) 1/EJ = 1/12 b/EJ$$

$$L_{GF}^{xx} = \int_0^b (1/4 - 1/2 x/b + 1/4 x^2/b^2) 1/EJ dx = [1/4 x - 1/4 x^2/b + 1/12 x^3/b^2]_0^b 1/EJ$$

$$= (1/4 b - 1/4 b + 1/12 b) 1/EJ = 1/12 b/EJ$$

$$L_{GD}^{xx} = \int_0^b (1 - 2 x/b + x^2/b^2) 1/EJ dx = [x - x^2/b + 1/3 x^3/b^2]_0^b 1/EJ$$

$$= (b - b + 1/3 b) 1/EJ = 1/3 b/EJ$$

$$L_{DG}^{xx} = \int_0^b (x^2/b^2) 1/EJ dx = [1/3 x^3/b^2]_0^b 1/EJ$$

$$= (1/3 b) 1/EJ = 1/3 b/EJ$$

$$L_{GA}^{xx} = \int_0^b (1/4 - 1/2 x/b + 1/4 x^2/b^2) 1/EJ dx = [1/4 x - 1/4 x^2/b + 1/12 x^3/b^2]_0^b 1/EJ$$

$$= (1/4 b - 1/4 b + 1/12 b) 1/EJ = 1/12 b/EJ$$

$$L_{AG}^{xx} = \int_0^b (1/4 x^2/b^2) 1/EJ dx = [1/12 x^3/b^2]_0^b 1/EJ$$

$$= (1/12 b) 1/EJ = 1/12 b/EJ$$

$$L_{FG}^{xo} = \int_0^b (-1/2 x/b + 5/8 x^2/b^2) Fb 1/EJ dx + \int_0^b (1/2 x/b) \theta dx$$

$$= [-1/4 x^2/b + 5/24 x^3/b^2]_0^b Fb 1/EJ + [1/4 x^2/b]_0^b \theta$$

$$= (-1/4 b + 5/24 b) Fb 1/EJ + (1/4 b) \theta = 5/24 Fb^2/EJ$$

$$L_{GF}^{xo} = \int_0^b (1/8 - 3/4 x/b + 5/8 x^2/b^2) Fb 1/EJ dx + \int_0^b (-1/2 + 1/2 x/b) \theta dx$$

$$= [1/8 x - 3/8 x^2/b + 5/24 x^3/b^2]_0^b Fb 1/EJ + [-1/2 x + 1/4 x^2/b]_0^b \theta$$

$$= (1/8 b - 3/8 b + 5/24 b) Fb 1/EJ + (-1/2 b + 1/4 b) \theta = 5/24 Fb^2/EJ$$

$$L_{GD}^{xo} = \int_0^b (x/b - x^2/b^2) Fb 1/EJ dx = [1/2 x^2/b - 1/3 x^3/b^2]_0^b Fb 1/EJ$$

$$= (1/2 b - 1/3 b) Fb 1/EJ = 1/6 Fb^2/EJ$$

$$L_{DG}^{xo} = \int_0^b (x/b - x^2/b^2) Fb 1/EJ dx = [1/2 x^2/b - 1/3 x^3/b^2]_0^b Fb 1/EJ$$

$$= (1/2 b - 1/3 b) Fb 1/EJ = 1/6 Fb^2/EJ$$

$$L_{GA}^{xo} = \int_0^b (-1/8 + 3/8 x^2/b^2 - 1/4 x^3/b^3) Fb 1/EJ dx = [-1/8 x + 1/8 x^3/b^2 - 1/16 x^4/b^3]_0^b Fb 1/EJ$$

$$= (-1/8 b + 1/8 b - 1/16 b) Fb 1/EJ = -1/16 Fb^2/EJ$$

$$L_{AG}^{xo} = \int_0^b (-3/8 x^2/b^2 + 1/4 x^3/b^3) Fb 1/EJ dx = [-1/8 x^3/b^2 + 1/16 x^4/b^3]_0^b Fb 1/EJ$$

$$= (-1/8 b + 1/16 b) Fb 1/EJ = -1/16 Fb^2/EJ$$

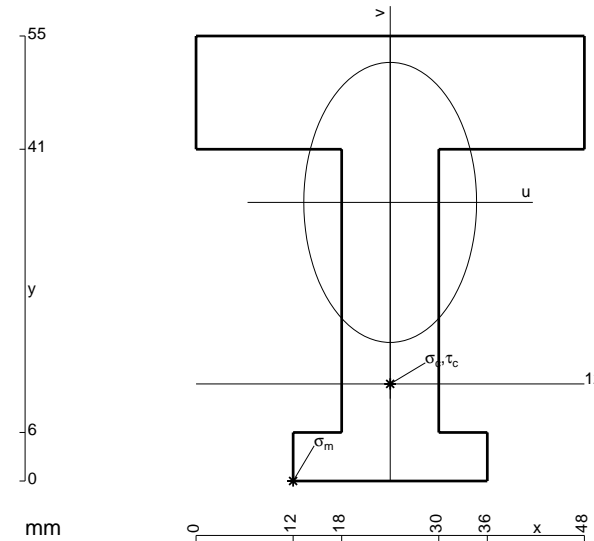

- A = 1236. mm²
- J_u = 370453. mm⁴
- J_v = 140976. mm⁴
- y_g = 34.43 mm
- T_y = -3580. N
- M_x = -2577600. Nmm
- x_m = 12. mm
- u_m = -12. mm
- v_m = -34.43 mm
- σ_m = -Mv/J_u = -239.6 N/mm²
- x_c = 24. mm
- y_c = 12. mm
- v_c = -22.43 mm
- σ_c = -Mv/J_u = -156.1 N/mm²
- τ_c = 5.12 N/mm²
- σ_q = √σ²+3τ² = 156.3 N/mm²
- S = 6357. mm³

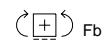
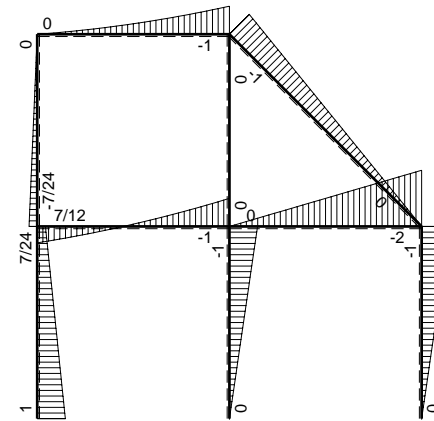
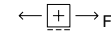
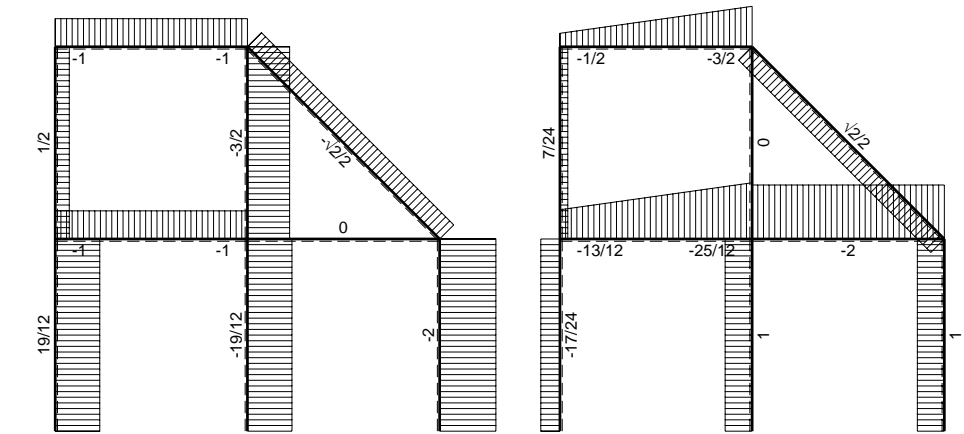
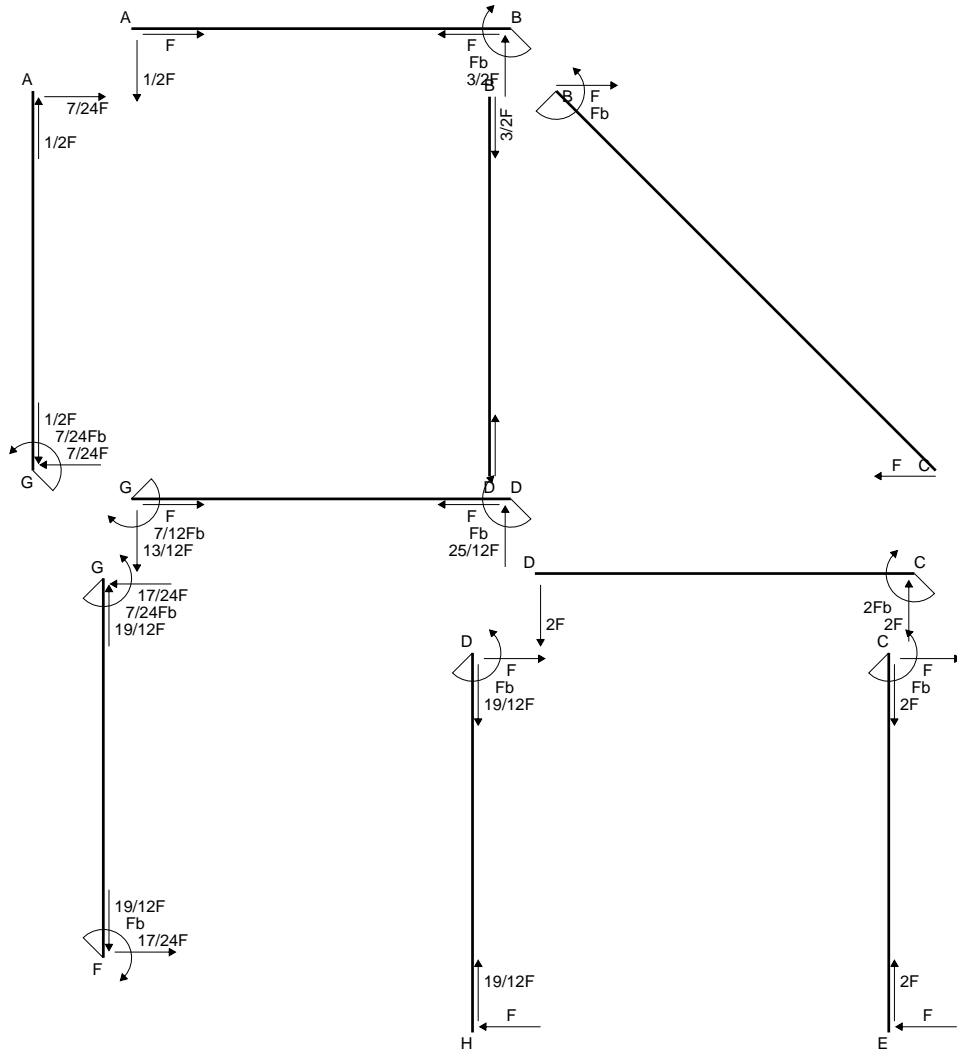

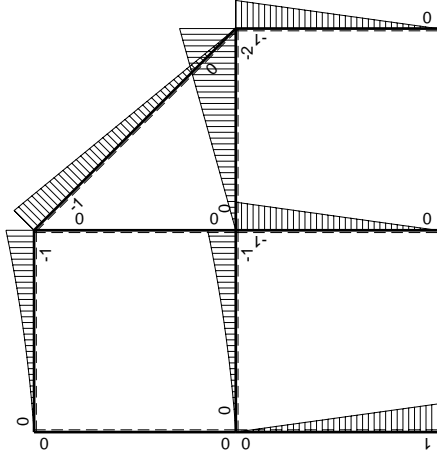
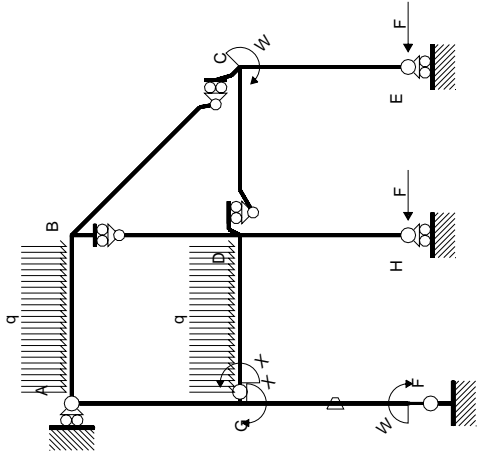

Schema di calcolo iperstatico

M_0 flessione da carichi assegnati

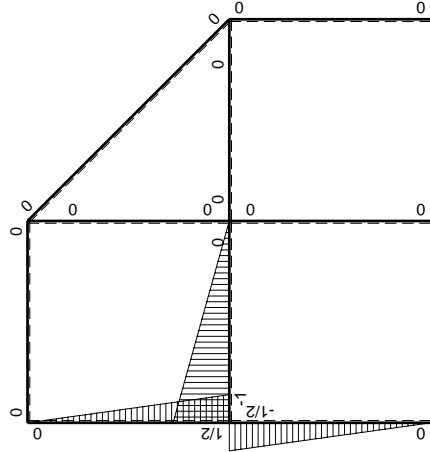

M_x flessione da iperstatica $X=1$

Quadro contributi PLV per iperstatica $X=W_{GD}$

→	$M_x(x)$	$M_o(x)$	θ	$M_x M_o$	$M_x \theta$	$M_x M_x$	$\int M_x(M_o/EJ+\theta)dx$	$\int X M_x M_x/EJdx$	
AB b	0	$-1/2Fx-1/2qx^2$	0	0	0	0	0+0	0	
BA b	0	$Fb-3/2Fx+1/2qx^2$	0	0	0	0			
BC $\sqrt{2}b$	0	$-Fb+\sqrt{2}/2Fx$	0	0	0	0	0	0	
BD b	0	0	0	0	0	0	0+0	0	
DB b	0	0	0	0	0	0			
DC b	0	$-2Fx$	0	0	0	0	0+0	0	
CD b	0	$2Fb-2Fx$	0	0	0	0			
CE b	0	$-Fb+Fx$	0	0	0	0	0+0	0	
EC b	0	Fx	0	0	0	0			
FG b	$-1/2x/b$	$Fb-Fx$	$-Fb/EJ$	$-1/2Fx+1/2Fx^2/b$	$1/2Fx/EJ$	$1/4x^2/b^2$	$(-1/12+1/4)Fb^2/EJ$	$1/12Xb/EJ$	
GF b	$1/2-1/2x/b$	$-Fx$	Fb/EJ	$-1/2Fx+1/2Fx^2/b$	$1/2Fb/EJ-1/2Fx/EJ$	$1/4-1/2x/b+1/4x^2/b^2$			
GD b	$-1+x/b$	$-1/2Fx-1/2qx^2$	0	$1/2Fx-1/2qx^3/b$	0	$1-2x/b+x^2/b^2$	$(1/8+0)Fb^2/EJ$	$1/3Xb/EJ$	
DG b	x/b	$Fb-3/2Fx+1/2qx^2$	0	$Fx-3/2Fx^2/b+1/2qx^3/b$	0	x^2/b^2			
DH b	0	$-Fb+Fx$	0	0	0	0	0+0	0	
HD b	0	Fx	0	0	0	0			
GA b	$1/2-1/2x/b$	0	0	0	0	$1/4-1/2x/b+1/4x^2/b^2$	0+0	$1/12Xb/EJ$	
AG b	$-1/2x/b$	0	0	0	0	$1/4x^2/b^2$			
	totali							$7/24Fb^2/EJ$	$1/2Xb/EJ$
	iperstatica $X=W_{GD}$							$-7/12Fb$	

Sviluppi di calcolo iperstatica

$$L_{FG}^{xx} = \int_0^b (1/4 x^2/b^2) 1/EJ dx = [1/12 x^3/b^2]_0^b 1/EJ$$

$$= (1/12 b) 1/EJ = 1/12 b/EJ$$

$$L_{GF}^{xx} = \int_0^b (1/4 - 1/2 x/b + 1/4 x^2/b^2) 1/EJ dx = [1/4 x - 1/4 x^2/b + 1/12 x^3/b^2]_0^b 1/EJ$$

$$= (1/4 b - 1/4 b + 1/12 b) 1/EJ = 1/12 b/EJ$$

$$L_{GD}^{xx} = \int_0^b (1 - 2 x/b + x^2/b^2) 1/EJ dx = [x - x^2/b + 1/3 x^3/b^2]_0^b 1/EJ$$

$$= (b - b + 1/3 b) 1/EJ = 1/3 b/EJ$$

$$L_{DG}^{xx} = \int_0^b (x^2/b^2) 1/EJ dx = [1/3 x^3/b^2]_0^b 1/EJ$$

$$= (1/3 b) 1/EJ = 1/3 b/EJ$$

$$L_{GA}^{xx} = \int_0^b (1/4 - 1/2 x/b + 1/4 x^2/b^2) 1/EJ dx = [1/4 x - 1/4 x^2/b + 1/12 x^3/b^2]_0^b 1/EJ$$

$$= (1/4 b - 1/4 b + 1/12 b) 1/EJ = 1/12 b/EJ$$

$$L_{AG}^{xx} = \int_0^b (1/4 x^2/b^2) 1/EJ dx = [1/12 x^3/b^2]_0^b 1/EJ$$

$$= (1/12 b) 1/EJ = 1/12 b/EJ$$

$$L_{FG}^{xo} = \int_0^b (-1/2 x/b + 1/2 x^2/b^2) Fb 1/EJ dx + \int_0^b (1/2 x/b) \theta dx$$

$$= [-1/4 x^2/b + 1/6 x^3/b^2]_0^b Fb 1/EJ + [1/4 x^2/b]_0^b \theta$$

$$= (-1/4 b + 1/6 b) Fb 1/EJ + (1/4 b) \theta = 1/6 Fb^2/EJ$$

$$L_{GF}^{xo} = \int_0^b (-1/2 x/b + 1/2 x^2/b^2) Fb 1/EJ dx + \int_0^b (-1/2 + 1/2 x/b) \theta dx$$

$$= [-1/4 x^2/b + 1/6 x^3/b^2]_0^b Fb 1/EJ + [-1/2 x + 1/4 x^2/b]_0^b \theta$$

$$= (-1/4 b + 1/6 b) Fb 1/EJ + (-1/2 b + 1/4 b) \theta = 1/6 Fb^2/EJ$$

$$L_{GD}^{xo} = \int_0^b (1/2 x/b - 1/2 x^3/b^3) Fb 1/EJ dx = [1/4 x^2/b - 1/8 x^4/b^3]_0^b Fb 1/EJ$$

$$= (1/4 b - 1/8 b) Fb 1/EJ = 1/8 Fb^2/EJ$$

$$L_{DG}^{xo} = \int_0^b (x/b - 3/2 x^2/b^2 + 1/2 x^3/b^3) Fb 1/EJ dx = [1/2 x^2/b - 1/2 x^3/b^2 + 1/8 x^4/b^3]_0^b Fb 1/EJ$$

$$= (1/2 b - 1/2 b + 1/8 b) Fb 1/EJ = 1/8 Fb^2/EJ$$

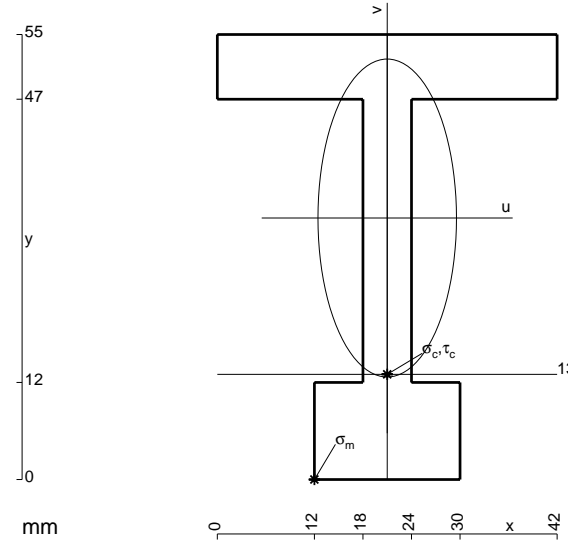

- A = 762. mm²
- J_u = 294369. mm⁴
- J_v = 55854. mm⁴
- y_g = 32.32 mm
- T_y = -2320. N
- M_x = -1809600. Nmm
- x_m = 12. mm
- u_m = -9. mm
- v_m = -32.32 mm
- σ_m = -Mv/J_u = -198.7 N/mm²
- x_c = 21. mm
- y_c = 13. mm
- v_c = -19.32 mm
- σ_c = -Mv/J_u = -118.8 N/mm²
- τ_c = 7.624 N/mm²
- σ_o = √σ²+3τ² = 119.5 N/mm²
- S = 5804. mm³

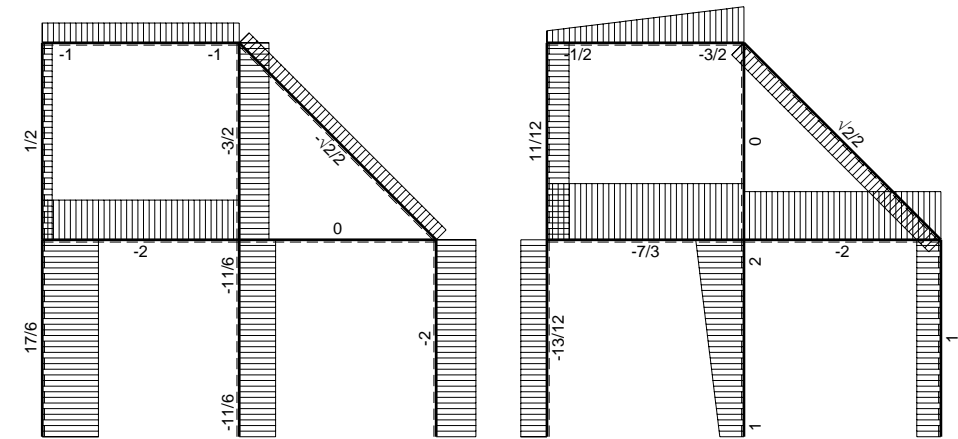
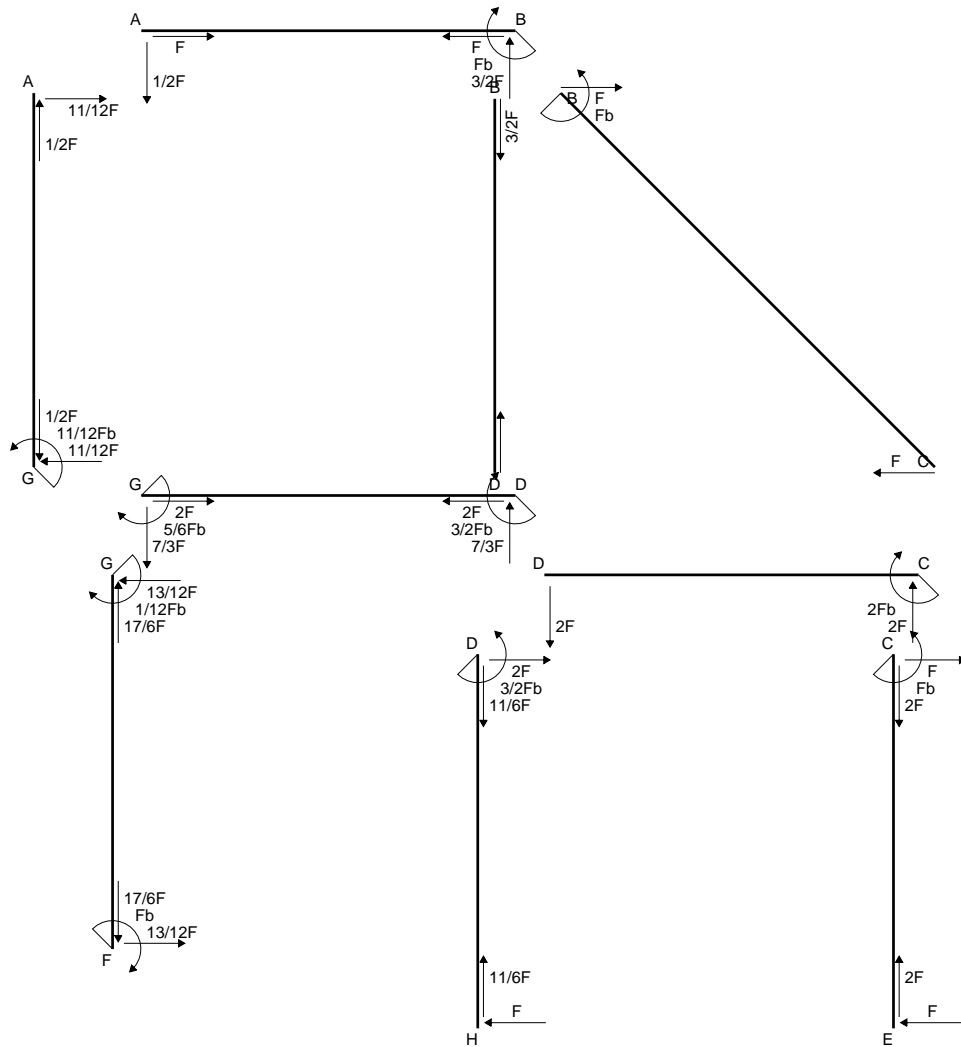

← ⊕ → F

↑ ⊕ ↓ F

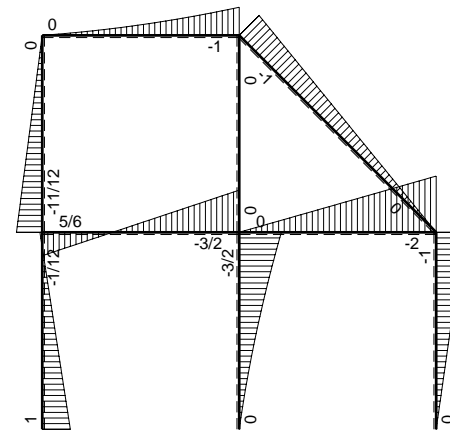

⊕ F_b

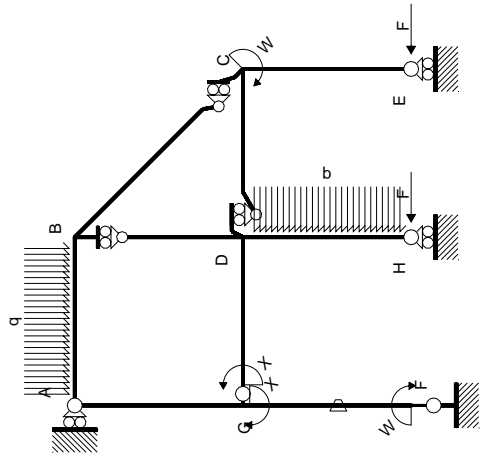

Schema di calcolo iperstatico

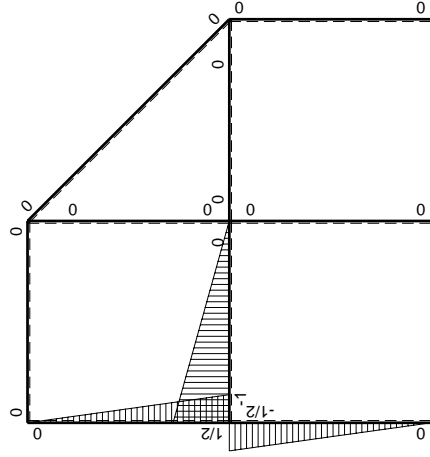

M_x flessione da iperstatica $X=1$

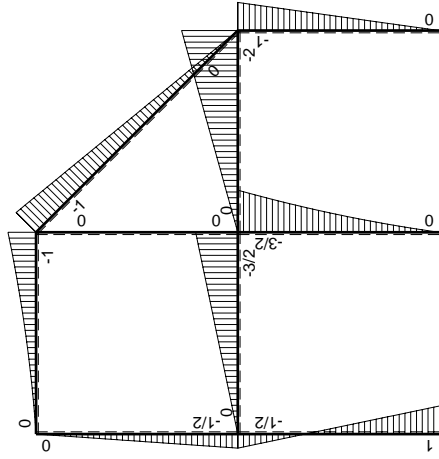

M_0 flessione da carichi assegnati

Quadro contributi PLV per iperstatica $X=W_{GD}$

→	$M_x(x)$	$M_o(x)$	θ	$M_x M_o$	$M_x \theta$	$M_x M_x$	$\int M_x(M_o/EJ+\theta)dx$	$\int X M_x M_x/EJdx$
AB b	0	$-1/2Fx-1/2qx^2$	0	0	0	0	0+0	0
BA b	0	$Fb-3/2Fx+1/2qx^2$	0	0	0	0		
BC $\sqrt{2}b$	0	$-Fb+\sqrt{2}/2Fx$	0	0	0	0	0	0
BD b	0	0	0	0	0	0	0+0	0
DB b	0	0	0	0	0	0		
DC b	0	$-2Fx$	0	0	0	0	0+0	0
CD b	0	$2Fb-2Fx$	0	0	0	0		
CE b	0	$-Fb+Fx$	0	0	0	0	0+0	0
EC b	0	Fx	0	0	0	0		
FG b	$-1/2x/b$	$Fb-3/2Fx$	$-Fb/EJ$	$-1/2Fx+3/4Fx^2/b$	$1/2Fx/EJ$	$1/4x^2/b^2$	$(0+1/4)Fb^2/EJ$	$1/12Xb/EJ$
GF b	$1/2-1/2x/b$	$1/2Fb-3/2Fx$	Fb/EJ	$1/4Fb-Fx+3/4Fx^2/b$	$1/2Fb/EJ-1/2Fx/EJ$	$1/4-1/2x/b+1/4x^2/b^2$		
GD b	$-1+x/b$	$-3/2Fx$	0	$3/2Fx-3/2Fx^2/b$	0	$1-2x/b+x^2/b^2$	$(1/4+0)Fb^2/EJ$	$1/3Xb/EJ$
DG b	x/b	$3/2Fb-3/2Fx$	0	$3/2Fx-3/2Fx^2/b$	0	x^2/b^2		
DH b	0	$-3/2Fb+2Fx-1/2qx^2$	0	0	0	0	0+0	0
HD b	0	$Fx+1/2qx^2$	0	0	0	0		
GA b	$1/2-1/2x/b$	$-1/2Fb+1/2Fx$	0	$-1/4Fb+1/2Fx-1/4Fx^2/b$	0	$1/4-1/2x/b+1/4x^2/b^2$	$(-1/12+0)Fb^2/EJ$	$1/12Xb/EJ$
AG b	$-1/2x/b$	$1/2Fx$	0	$-1/4Fx^2/b$	0	$1/4x^2/b^2$		
	totali						$5/12Fb^2/EJ$	$1/2Xb/EJ$
	iperstatica $X=W_{GD}$						$-5/6Fb$	

Sviluppi di calcolo iperstatica

$$L_{FG}^{xx} = \int_0^b (1/4 x^2/b^2) 1/EJ dx = [1/12 x^3/b^2]_0^b 1/EJ$$

$$= (1/12 b) 1/EJ = 1/12 b/EJ$$

$$L_{GF}^{xx} = \int_0^b (1/4 - 1/2 x/b + 1/4 x^2/b^2) 1/EJ dx = [1/4 x - 1/4 x^2/b + 1/12 x^3/b^2]_0^b 1/EJ$$

$$= (1/4 b - 1/4 b + 1/12 b) 1/EJ = 1/12 b/EJ$$

$$L_{GD}^{xx} = \int_0^b (1 - 2 x/b + x^2/b^2) 1/EJ dx = [x - x^2/b + 1/3 x^3/b^2]_0^b 1/EJ$$

$$= (b - b + 1/3 b) 1/EJ = 1/3 b/EJ$$

$$L_{DG}^{xx} = \int_0^b (x^2/b^2) 1/EJ dx = [1/3 x^3/b^2]_0^b 1/EJ$$

$$= (1/3 b) 1/EJ = 1/3 b/EJ$$

$$L_{GA}^{xx} = \int_0^b (1/4 - 1/2 x/b + 1/4 x^2/b^2) 1/EJ dx = [1/4 x - 1/4 x^2/b + 1/12 x^3/b^2]_0^b 1/EJ$$

$$= (1/4 b - 1/4 b + 1/12 b) 1/EJ = 1/12 b/EJ$$

$$L_{AG}^{xx} = \int_0^b (1/4 x^2/b^2) 1/EJ dx = [1/12 x^3/b^2]_0^b 1/EJ$$

$$= (1/12 b) 1/EJ = 1/12 b/EJ$$

$$L_{FG}^{xo} = \int_0^b (-1/2 x/b + 3/4 x^2/b^2) Fb 1/EJ dx + \int_0^b (1/2 x/b) \theta dx$$

$$= [-1/4 x^2/b + 1/4 x^3/b^2]_0^b Fb 1/EJ + [1/4 x^2/b]_0^b \theta$$

$$= (-1/4 b + 1/4 b) Fb 1/EJ + (1/4 b) \theta = 1/4 Fb^2/EJ$$

$$L_{GF}^{xo} = \int_0^b (1/4 - x/b + 3/4 x^2/b^2) Fb 1/EJ dx + \int_0^b (-1/2 + 1/2 x/b) \theta dx$$

$$= [1/4 x - 1/2 x^2/b + 1/4 x^3/b^2]_0^b Fb 1/EJ + [-1/2 x + 1/4 x^2/b]_0^b \theta$$

$$= (1/4 b - 1/2 b + 1/4 b) Fb 1/EJ + (-1/2 b + 1/4 b) \theta = 1/4 Fb^2/EJ$$

$$L_{GD}^{xo} = \int_0^b (3/2 x/b - 3/2 x^2/b^2) Fb 1/EJ dx = [3/4 x^2/b - 1/2 x^3/b^2]_0^b Fb 1/EJ$$

$$= (3/4 b - 1/2 b) Fb 1/EJ = 1/4 Fb^2/EJ$$

$$L_{DG}^{xo} = \int_0^b (3/2 x/b - 3/2 x^2/b^2) Fb 1/EJ dx = [3/4 x^2/b - 1/2 x^3/b^2]_0^b Fb 1/EJ$$

$$= (3/4 b - 1/2 b) Fb 1/EJ = 1/4 Fb^2/EJ$$

$$L_{GA}^{xo} = \int_0^b (-1/4 + 1/2 x/b - 1/4 x^2/b^2) Fb 1/EJ dx = [-1/4 x + 1/4 x^2/b - 1/12 x^3/b^2]_0^b Fb 1/EJ$$

$$= (-1/4 b + 1/4 b - 1/12 b) Fb 1/EJ = -1/12 Fb^2/EJ$$

$$L_{AG}^{xo} = \int_0^b (-1/4 x^2/b^2) Fb 1/EJ dx = [-1/12 x^3/b^2]_0^b Fb 1/EJ$$

$$= (-1/12 b) Fb 1/EJ = -1/12 Fb^2/EJ$$

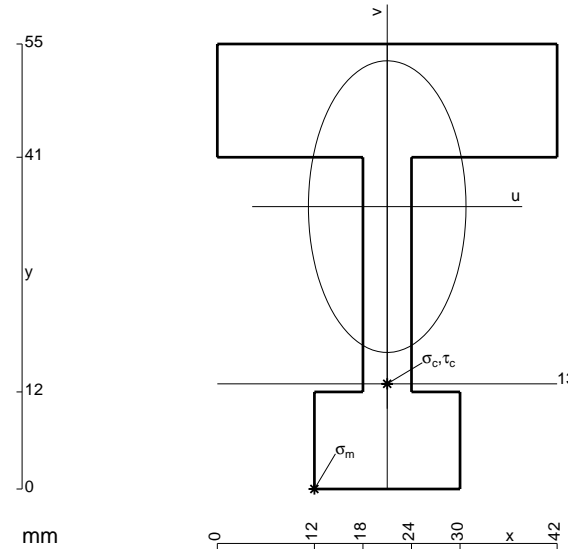

- A = 978. mm²
- J_u = 317980. mm⁴
- J_v = 92790. mm⁴
- y_g = 34.9 mm
- T_y = -2300. N
- M_x = -1909000. Nmm
- x_m = 12. mm
- u_m = -9. mm
- v_m = -34.9 mm
- σ_m = -Mv/J_u = -209.5 N/mm²
- x_c = 21. mm
- y_c = 13. mm
- v_c = -21.9 mm
- σ_c = -Mv/J_u = -131.5 N/mm²
- τ_c = 7.687 N/mm²
- σ_q = √σ²+3τ² = 132.1 N/mm²
- S = 6377. mm³

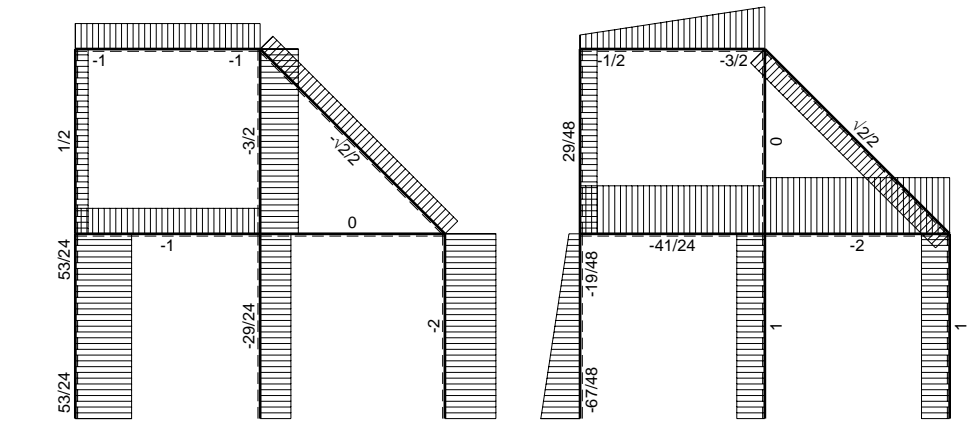
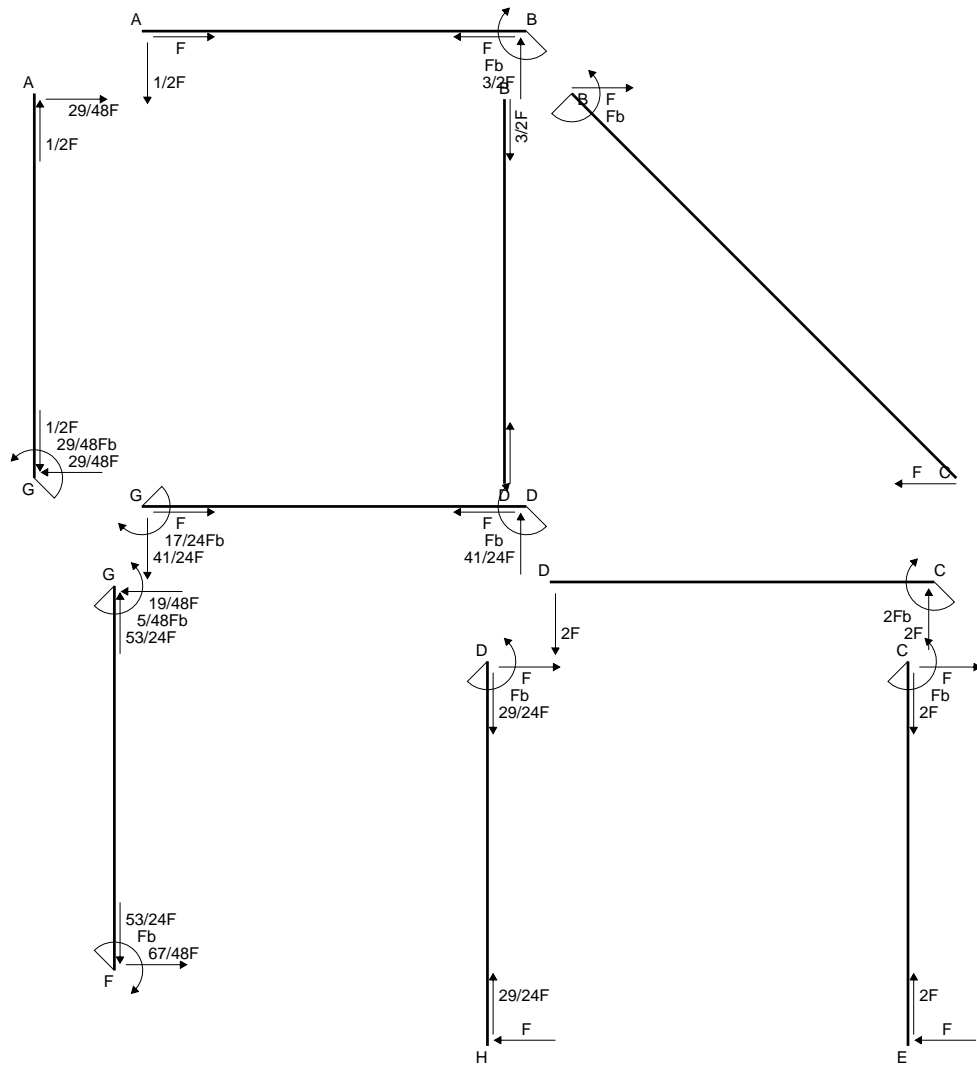

← ⊕ → F

↑ ⊕ ↓ F

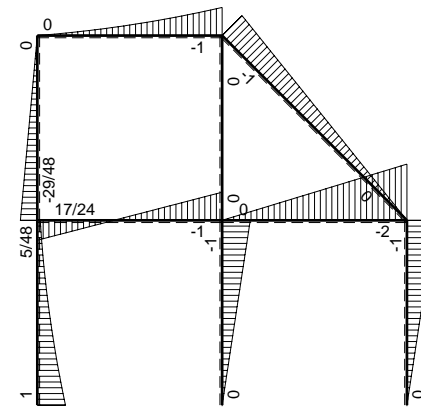

⊕ ⊖ F_b

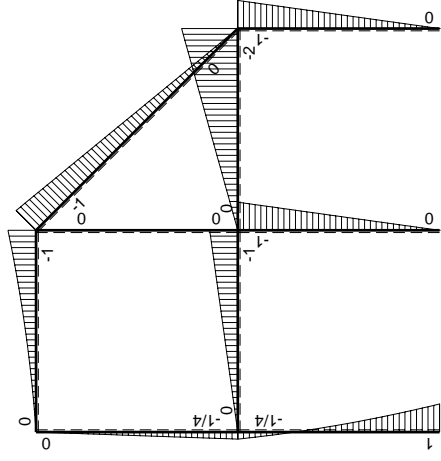
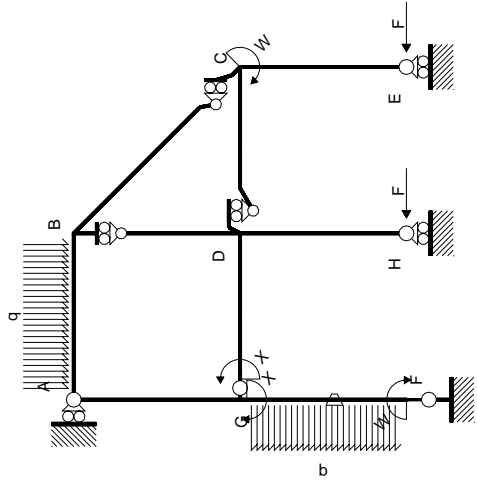

Schema di calcolo iperstatico

M_0 flessione da carichi assegnati

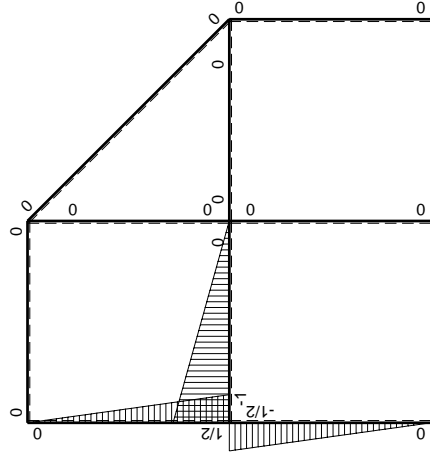

M_x flessione da iperstatica $X=1$

Quadro contributi PLV per iperstatica $X=W_{GD}$

→	$M_x(x)$	$M_o(x)$	θ	$M_x M_o$	$M_x \theta$	$M_x M_x$	$\int M_x(M_o/EJ+\theta)dx$	$\int X M_x M_x/EJ dx$	
AB b	0	$-1/2Fx-1/2qx^2$	0	0	0	0	0+0	0	
BA b	0	$Fb-3/2Fx+1/2qx^2$	0	0	0	0	0	0	
BC $\sqrt{2}b$	0	$-Fb+\sqrt{2}/2Fx$	0	0	0	0	0	0	
BD b	0	0	0	0	0	0	0+0	0	
DB b	0	0	0	0	0	0	0	0	
DC b	0	$-2Fx$	0	0	0	0	0+0	0	
CD b	0	$2Fb-2Fx$	0	0	0	0	0	0	
CE b	0	$-Fb+Fx$	0	0	0	0	0+0	0	
EC b	0	Fx	0	0	0	0	0	0	
FG b	$-1/2x/b$	$Fb-7/4Fx+1/2qx^2$	$-Fb/EJ$	$-1/2Fx+7/8Fx^2/b-1/4qx^3/b$	$1/2Fx/EJ$	$1/4x^2/b^2$	$(-1/48+1/4)Fb^2/EJ$	$1/12Xb/EJ$	
GF b	$1/2-1/2x/b$	$1/4Fb-3/4Fx-1/2qx^2$	Fb/EJ	$1/8Fb-1/2Fx+1/8Fx^2/b+1/4qx^3/b$	$1/2Fb/EJ-1/2Fx/EJ$	$1/4-1/2x/b+1/4x^2/b^2$			
GD b	$-1+x/b$	$-Fx$	0	$Fx-Fx^2/b$	0	$1-2x/b+x^2/b^2$	$(1/6+0)Fb^2/EJ$	$1/3Xb/EJ$	
DG b	x/b	$Fb-Fx$	0	$Fx-Fx^2/b$	0	x^2/b^2			
DH b	0	$-Fb+Fx$	0	0	0	0	0+0	0	
HD b	0	Fx	0	0	0	0	0	0	
GA b	$1/2-1/2x/b$	$-1/4Fb+1/4Fx$	0	$-1/8Fb+1/4Fx-1/8Fx^2/b$	0	$1/4-1/2x/b+1/4x^2/b^2$	$(-1/24+0)Fb^2/EJ$	$1/12Xb/EJ$	
AG b	$-1/2x/b$	$1/4Fx$	0	$-1/8Fx^2/b$	0	$1/4x^2/b^2$			
	totali							$17/48Fb^2/EJ$	$1/2Xb/EJ$
	iperstatica $X=W_{GD}$							$-17/24Fb$	

Sviluppi di calcolo iperstatica

$$L_{FG}^{xx} = \int_0^b (1/4 x^2/b^2) 1/EJ dx = [1/12 x^3/b^2]_0^b 1/EJ$$

$$= (1/12 b) 1/EJ = 1/12 b/EJ$$

$$L_{GF}^{xx} = \int_0^b (1/4 - 1/2 x/b + 1/4 x^2/b^2) 1/EJ dx = [1/4 x - 1/4 x^2/b + 1/12 x^3/b^2]_0^b 1/EJ$$

$$= (1/4 b - 1/4 b + 1/12 b) 1/EJ = 1/12 b/EJ$$

$$L_{GD}^{xx} = \int_0^b (1 - 2 x/b + x^2/b^2) 1/EJ dx = [x - x^2/b + 1/3 x^3/b^2]_0^b 1/EJ$$

$$= (b - b + 1/3 b) 1/EJ = 1/3 b/EJ$$

$$L_{DG}^{xx} = \int_0^b (x^2/b^2) 1/EJ dx = [1/3 x^3/b^2]_0^b 1/EJ$$

$$= (1/3 b) 1/EJ = 1/3 b/EJ$$

$$L_{GA}^{xx} = \int_0^b (1/4 - 1/2 x/b + 1/4 x^2/b^2) 1/EJ dx = [1/4 x - 1/4 x^2/b + 1/12 x^3/b^2]_0^b 1/EJ$$

$$= (1/4 b - 1/4 b + 1/12 b) 1/EJ = 1/12 b/EJ$$

$$L_{AG}^{xx} = \int_0^b (1/4 x^2/b^2) 1/EJ dx = [1/12 x^3/b^2]_0^b 1/EJ$$

$$= (1/12 b) 1/EJ = 1/12 b/EJ$$

$$L_{FG}^{xo} = \int_0^b (-1/2 x/b + 7/8 x^2/b^2 - 1/4 x^3/b^3) Fb 1/EJ dx + \int_0^b (1/2 x/b) \theta dx$$

$$= [-1/4 x^2/b + 7/24 x^3/b^2 - 1/16 x^4/b^3]_0^b Fb 1/EJ + [1/4 x^2/b]_0^b \theta$$

$$= (-1/4 b + 7/24 b - 1/16 b) Fb 1/EJ + (1/4 b) \theta = 11/48 Fb^2/EJ$$

$$L_{GF}^{xo} = \int_0^b (1/8 - 1/2 x/b + 1/8 x^2/b^2 + 1/4 x^3/b^3) Fb 1/EJ dx + \int_0^b (-1/2 + 1/2 x/b) \theta dx$$

$$= [1/8 x - 1/4 x^2/b + 1/24 x^3/b^2 + 1/16 x^4/b^3]_0^b Fb 1/EJ + [-1/2 x + 1/4 x^2/b]_0^b \theta$$

$$= (1/8 b - 1/4 b + 1/24 b + 1/16 b) Fb 1/EJ + (-1/2 b + 1/4 b) \theta = 11/48 Fb^2/EJ$$

$$L_{GD}^{xo} = \int_0^b (x/b - x^2/b^2) Fb 1/EJ dx = [1/2 x^2/b - 1/3 x^3/b^2]_0^b Fb 1/EJ$$

$$= (1/2 b - 1/3 b) Fb 1/EJ = 1/6 Fb^2/EJ$$

$$L_{DG}^{xo} = \int_0^b (x/b - x^2/b^2) Fb 1/EJ dx = [1/2 x^2/b - 1/3 x^3/b^2]_0^b Fb 1/EJ$$

$$= (1/2 b - 1/3 b) Fb 1/EJ = 1/6 Fb^2/EJ$$

$$L_{GA}^{xo} = \int_0^b (-1/8 + 1/4 x/b - 1/8 x^2/b^2) Fb 1/EJ dx = [-1/8 x + 1/8 x^2/b - 1/24 x^3/b^2]_0^b Fb 1/EJ$$

$$= (-1/8 b + 1/8 b - 1/24 b) Fb 1/EJ = -1/24 Fb^2/EJ$$

$$L_{AG}^{xo} = \int_0^b (-1/8 x^2/b^2) Fb 1/EJ dx = [-1/24 x^3/b^2]_0^b Fb 1/EJ$$

$$= (-1/24 b) Fb 1/EJ = -1/24 Fb^2/EJ$$

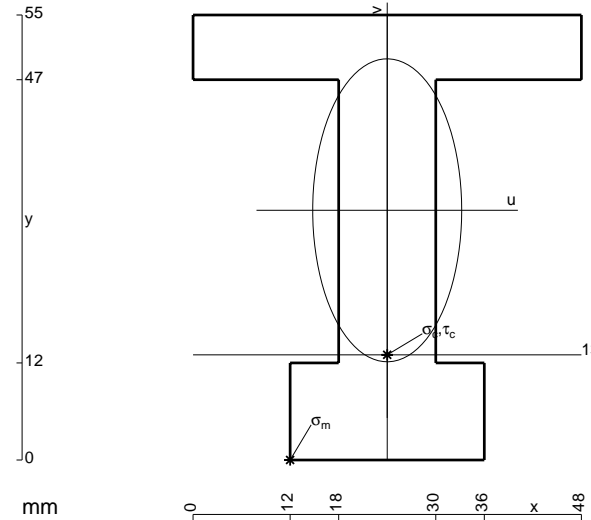

- A = 1092. mm²
- J_u = 382903. mm⁴
- J_v = 92592. mm⁴
- y_g = 30.86 mm
- T_y = -3100. N
- M_x = -2728000. Nmm
- x_m = 12. mm
- u_m = -12. mm
- v_m = -30.86 mm
- σ_m = -Mv/J_u = -219.9 N/mm²
- x_c = 24. mm
- y_c = 13. mm
- v_c = -17.86 mm
- σ_c = -Mv/J_u = -127.3 N/mm²
- τ_c = 4.98 N/mm²
- σ_q = √σ² + 3τ² = 127.6 N/mm²
- S = 7381. mm³

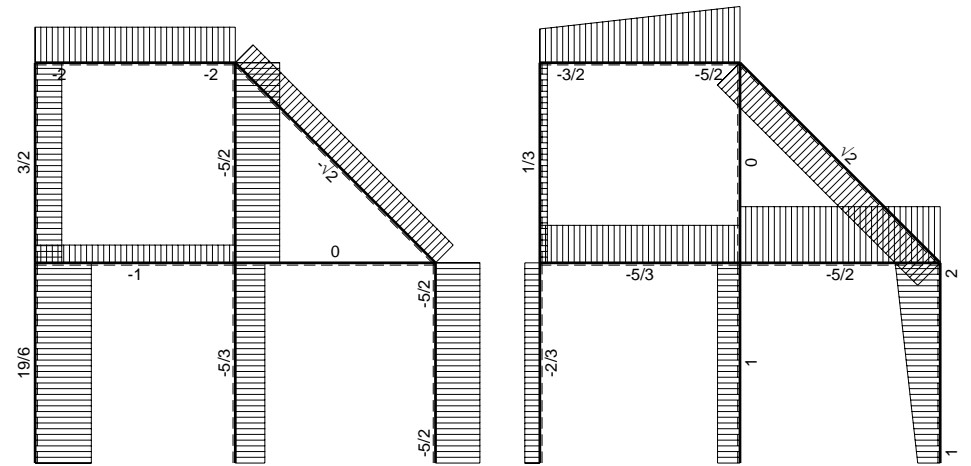
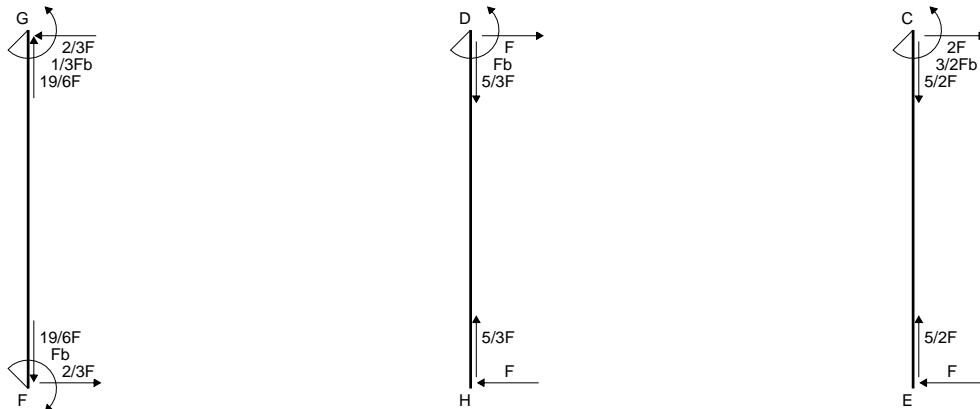
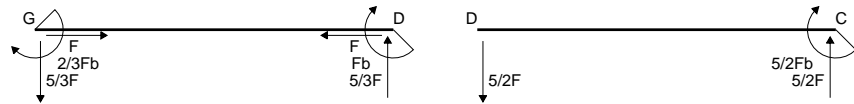
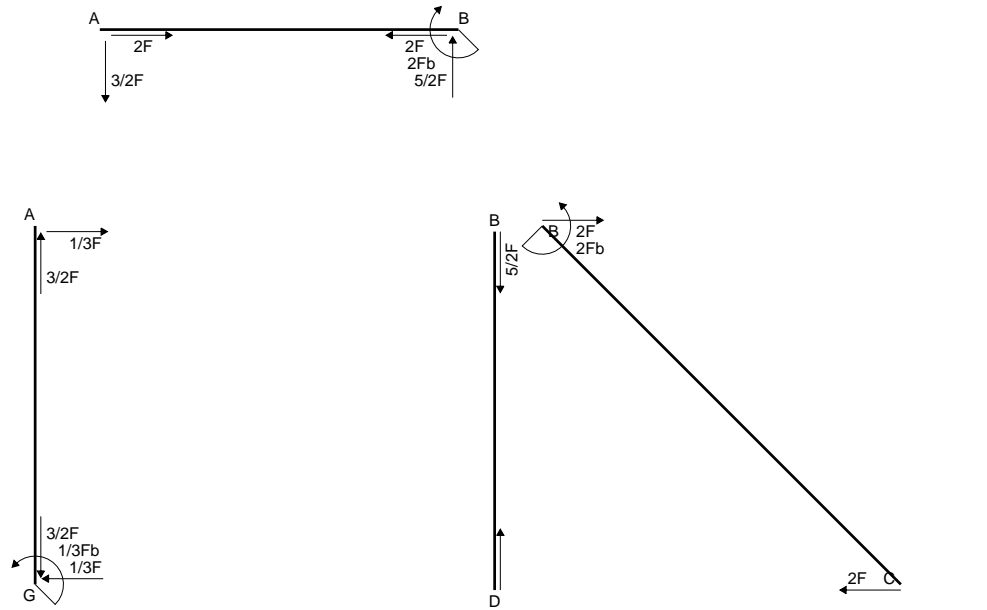

← ⊕ → F

↑ ⊕ ↓ F

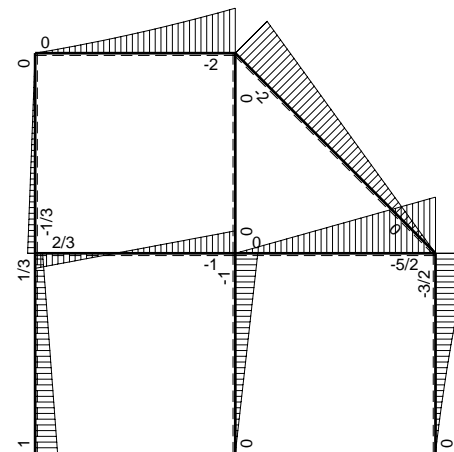

⊕ ⊖ F_b

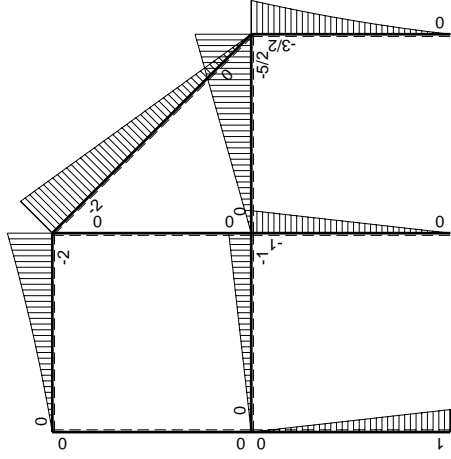
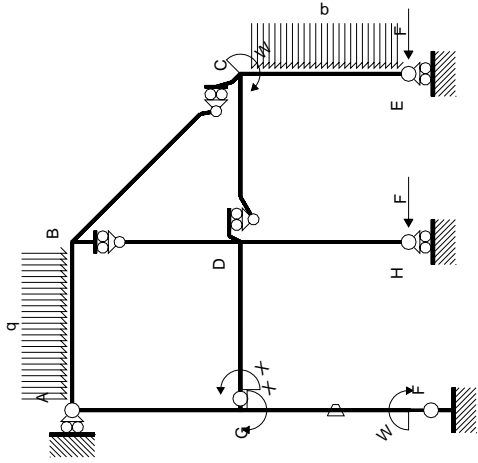

Schema di calcolo iperstatico

M_0 flessione da carichi assegnati

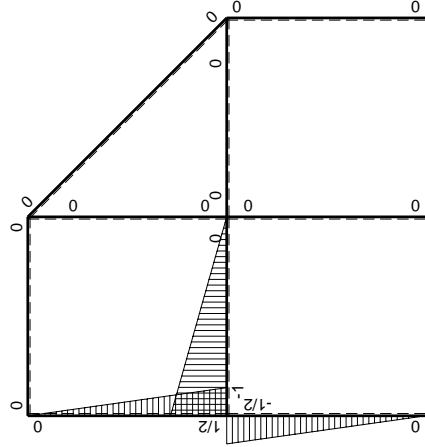

M_x flessione da iperstatica $X=1$

Quadro contributi PLV per iperstatica $X=W_{GD}$

→	$M_x(x)$	$M_o(x)$	θ	$M_x M_o$	$M_x \theta$	$M_x M_x$	$\int M_x(M_o/EJ+\theta)dx$	$\int X M_x M_x/EJdx$	
AB b	0	$-3/2Fx-1/2qx^2$	0	0	0	0	0+0	0	
BA b	0	$2Fb-5/2Fx+1/2qx^2$	0	0	0	0			
BC $\sqrt{2}b$	0	$-2Fb+\sqrt{2}Fx$	0	0	0	0	0	0	
BD b	0	0	0	0	0	0	0+0	0	
DB b	0	0	0	0	0	0			
DC b	0	$-5/2Fx$	0	0	0	0	0+0	0	
CD b	0	$5/2Fb-5/2Fx$	0	0	0	0			
CE b	0	$-3/2Fb+2Fx-1/2qx^2$	0	0	0	0	0+0	0	
EC b	0	$Fx+1/2qx^2$	0	0	0	0			
FG b	$-1/2x/b$	$Fb-Fx$	$-Fb/EJ$	$-1/2Fx+1/2Fx^2/b$	$1/2Fx/EJ$	$1/4x^2/b^2$	$(-1/12+1/4)Fb^2/EJ$	$1/12Xb/EJ$	
GF b	$1/2-1/2x/b$	$-Fx$	Fb/EJ	$-1/2Fx+1/2Fx^2/b$	$1/2Fb/EJ-1/2Fx/EJ$	$1/4-1/2x/b+1/4x^2/b^2$			
GD b	$-1+x/b$	$-Fx$	0	$Fx-Fx^2/b$	0	$1-2x/b+x^2/b^2$	$(1/6+0)Fb^2/EJ$	$1/3Xb/EJ$	
DG b	x/b	$Fb-Fx$	0	$Fx-Fx^2/b$	0	x^2/b^2			
DH b	0	$-Fb+Fx$	0	0	0	0	0+0	0	
HD b	0	Fx	0	0	0	0			
GA b	$1/2-1/2x/b$	0	0	0	0	$1/4-1/2x/b+1/4x^2/b^2$	0+0	$1/12Xb/EJ$	
AG b	$-1/2x/b$	0	0	0	0	$1/4x^2/b^2$			
	totali							$1/3Fb^2/EJ$	$1/2Xb/EJ$
	iperstatica $X=W_{GD}$							$-2/3Fb$	

Sviluppi di calcolo iperstatica

$$L_{FG}^{xx} = \int_0^b (1/4 x^2/b^2) 1/EJ dx = [1/12 x^3/b^2]_0^b 1/EJ$$

$$= (1/12 b) 1/EJ = 1/12 b/EJ$$

$$L_{GF}^{xx} = \int_0^b (1/4 - 1/2 x/b + 1/4 x^2/b^2) 1/EJ dx = [1/4 x - 1/4 x^2/b + 1/12 x^3/b^2]_0^b 1/EJ$$

$$= (1/4 b - 1/4 b + 1/12 b) 1/EJ = 1/12 b/EJ$$

$$L_{GD}^{xx} = \int_0^b (1 - 2 x/b + x^2/b^2) 1/EJ dx = [x - x^2/b + 1/3 x^3/b^2]_0^b 1/EJ$$

$$= (b - b + 1/3 b) 1/EJ = 1/3 b/EJ$$

$$L_{DG}^{xx} = \int_0^b (x^2/b^2) 1/EJ dx = [1/3 x^3/b^2]_0^b 1/EJ$$

$$= (1/3 b) 1/EJ = 1/3 b/EJ$$

$$L_{GA}^{xx} = \int_0^b (1/4 - 1/2 x/b + 1/4 x^2/b^2) 1/EJ dx = [1/4 x - 1/4 x^2/b + 1/12 x^3/b^2]_0^b 1/EJ$$

$$= (1/4 b - 1/4 b + 1/12 b) 1/EJ = 1/12 b/EJ$$

$$L_{AG}^{xx} = \int_0^b (1/4 x^2/b^2) 1/EJ dx = [1/12 x^3/b^2]_0^b 1/EJ$$

$$= (1/12 b) 1/EJ = 1/12 b/EJ$$

$$L_{FG}^{xo} = \int_0^b (-1/2 x/b + 1/2 x^2/b^2) Fb 1/EJ dx + \int_0^b (1/2 x/b) \theta dx$$

$$= [-1/4 x^2/b + 1/6 x^3/b^2]_0^b Fb 1/EJ + [1/4 x^2/b]_0^b \theta$$

$$= (-1/4 b + 1/6 b) Fb 1/EJ + (1/4 b) \theta = 1/6 Fb^2/EJ$$

$$L_{GF}^{xo} = \int_0^b (-1/2 x/b + 1/2 x^2/b^2) Fb 1/EJ dx + \int_0^b (-1/2 + 1/2 x/b) \theta dx$$

$$= [-1/4 x^2/b + 1/6 x^3/b^2]_0^b Fb 1/EJ + [-1/2 x + 1/4 x^2/b]_0^b \theta$$

$$= (-1/4 b + 1/6 b) Fb 1/EJ + (-1/2 b + 1/4 b) \theta = 1/6 Fb^2/EJ$$

$$L_{GD}^{xo} = \int_0^b (x/b - x^2/b^2) Fb 1/EJ dx = [1/2 x^2/b - 1/3 x^3/b^2]_0^b Fb 1/EJ$$

$$= (1/2 b - 1/3 b) Fb 1/EJ = 1/6 Fb^2/EJ$$

$$L_{DG}^{xo} = \int_0^b (x/b - x^2/b^2) Fb 1/EJ dx = [1/2 x^2/b - 1/3 x^3/b^2]_0^b Fb 1/EJ$$

$$= (1/2 b - 1/3 b) Fb 1/EJ = 1/6 Fb^2/EJ$$

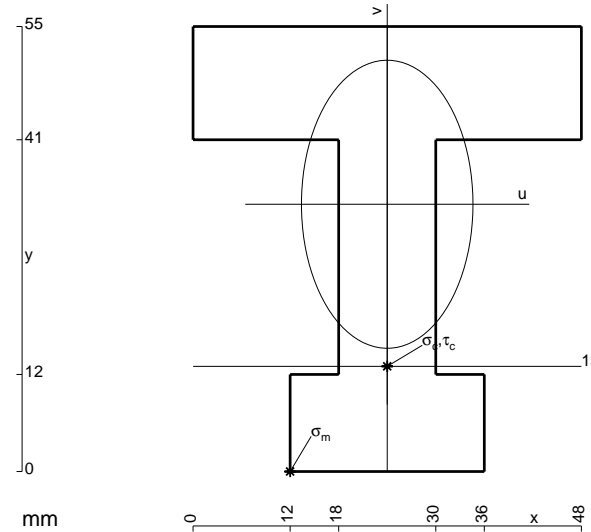

$$A = 1308. \text{ mm}^2$$

$$J_u = 414675. \text{ mm}^4$$

$$J_v = 147024. \text{ mm}^4$$

$$y_g = 33.03 \text{ mm}$$

$$T_y = -3100. \text{ N}$$

$$M_x = -2883000. \text{ Nmm}$$

$$x_m = 12. \text{ mm}$$

$$u_m = -12. \text{ mm}$$

$$v_m = -33.03 \text{ mm}$$

$$\sigma_m = -Mv/J_u = -229.7 \text{ N/mm}^2$$

$$x_c = 24. \text{ mm}$$

$$y_c = 13. \text{ mm}$$

$$v_c = -20.03 \text{ mm}$$

$$\sigma_c = -Mv/J_u = -139.3 \text{ N/mm}^2$$

$$\tau_c = 5.004 \text{ N/mm}^2$$

$$\sigma_o = \sqrt{\sigma^2 + 3\tau^2} = 139.5 \text{ N/mm}^2$$

$$S = 8032. \text{ mm}^3$$

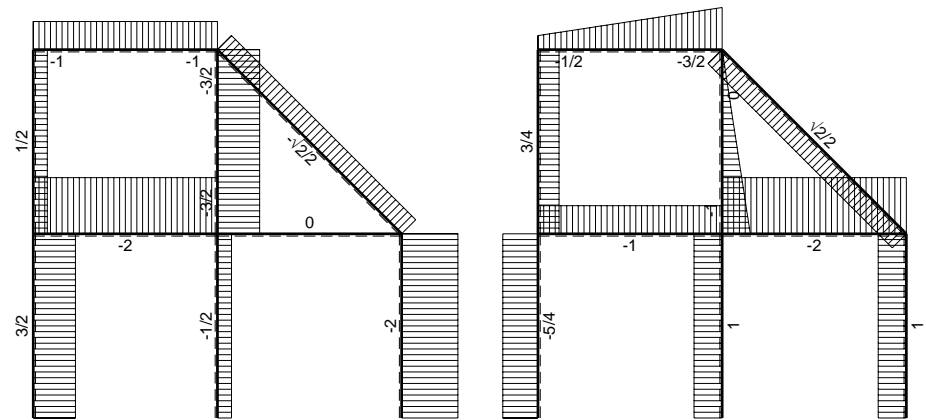
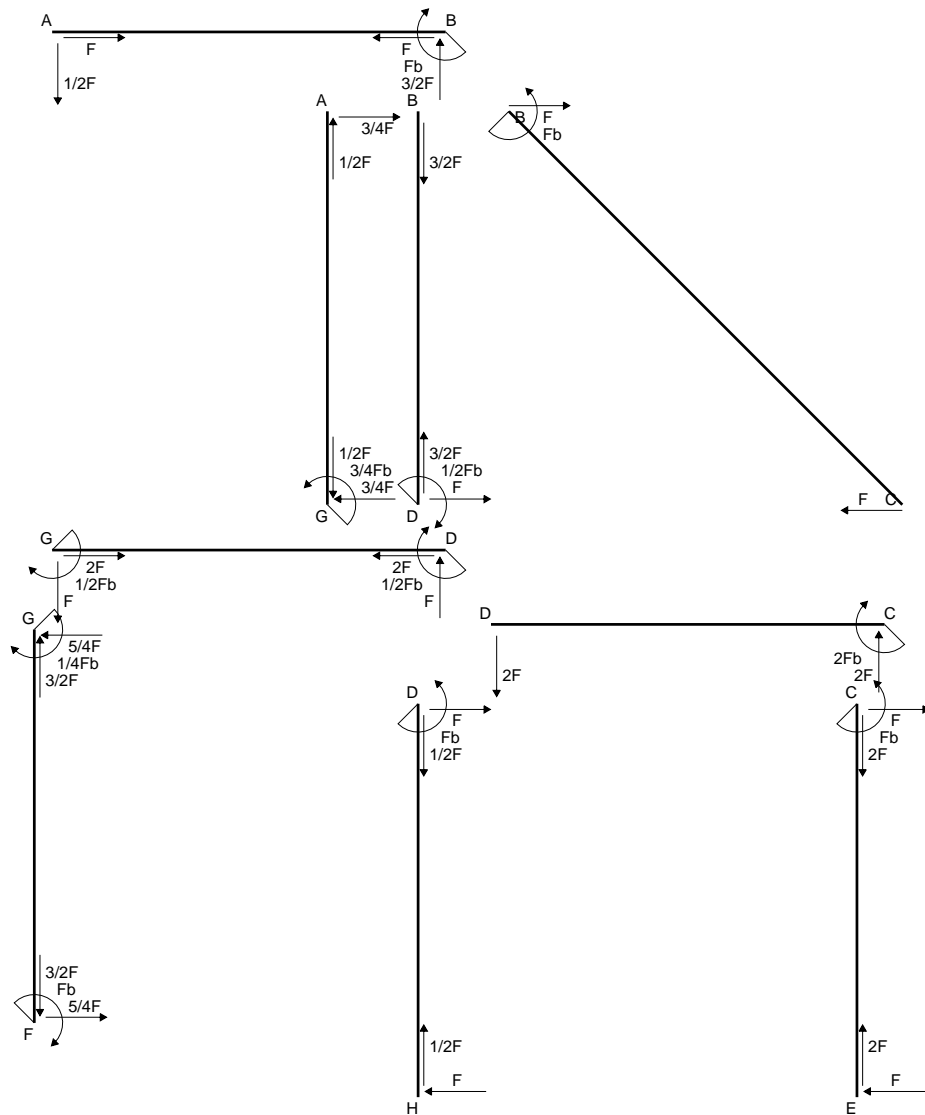

← ⊕ → F

↑ ⊕ ↓ F

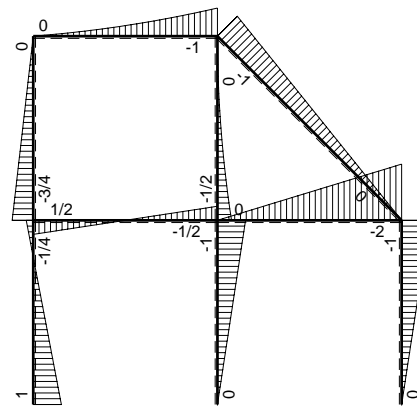

⊕ F_b

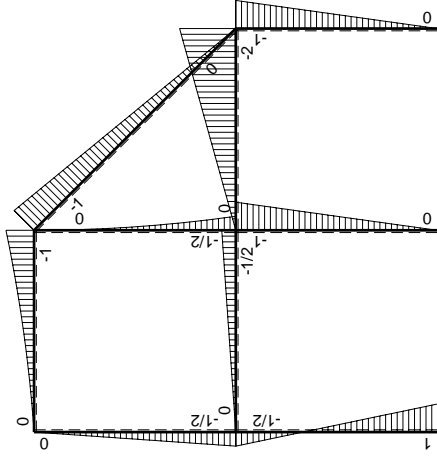
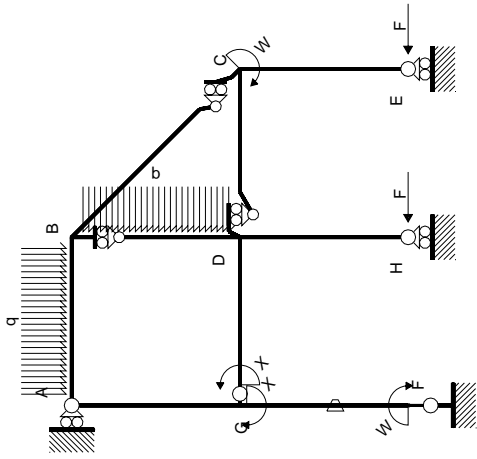

Schema di calcolo iperstatico

M_0 flessione da carichi assegnati

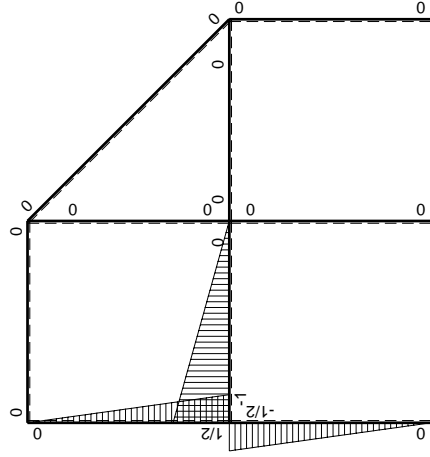

M_x flessione da iperstatica $X=1$

Quadro contributi PLV per iperstatica $X=W_{GD}$

→	$M_x(x)$	$M_o(x)$	θ	$M_x M_o$	$M_x \theta$	$M_x M_x$	$\int M_x(M_o/EJ+\theta)dx$	$\int X M_x M_x/EJdx$	
AB b	0	$-1/2Fx-1/2qx^2$	0	0	0	0	0+0	0	
BA b	0	$Fb-3/2Fx+1/2qx^2$	0	0	0	0			
BC $\sqrt{2}b$	0	$-Fb+\sqrt{2}/2Fx$	0	0	0	0	0	0	
BD b	0	$-1/2qx^2$	0	0	0	0	0+0	0	
DB b	0	$1/2Fb-Fx+1/2qx^2$	0	0	0	0			
DC b	0	$-2Fx$	0	0	0	0	0+0	0	
CD b	0	$2Fb-2Fx$	0	0	0	0			
CE b	0	$-Fb+Fx$	0	0	0	0	0+0	0	
EC b	0	Fx	0	0	0	0			
FG b	$-1/2x/b$	$Fb-3/2Fx$	$-Fb/EJ$	$-1/2Fx+3/4Fx^2/b$	$1/2Fx/EJ$	$1/4x^2/b^2$	$(0+1/4)Fb^2/EJ$	$1/12Xb/EJ$	
GF b	$1/2-1/2x/b$	$1/2Fb-3/2Fx$	Fb/EJ	$1/4Fb-Fx+3/4Fx^2/b$	$1/2Fb/EJ-1/2Fx/EJ$	$1/4-1/2x/b+1/4x^2/b^2$			
GD b	$-1+x/b$	$-1/2Fx$	0	$1/2Fx-1/2Fx^2/b$	0	$1-2x/b+x^2/b^2$	$(1/12+0)Fb^2/EJ$	$1/3Xb/EJ$	
DG b	x/b	$1/2Fb-1/2Fx$	0	$1/2Fx-1/2Fx^2/b$	0	x^2/b^2			
DH b	0	$-Fb+Fx$	0	0	0	0	0+0	0	
HD b	0	Fx	0	0	0	0			
GA b	$1/2-1/2x/b$	$-1/2Fb+1/2Fx$	0	$-1/4Fb+1/2Fx-1/4Fx^2/b$	0	$1/4-1/2x/b+1/4x^2/b^2$	$(-1/12+0)Fb^2/EJ$	$1/12Xb/EJ$	
AG b	$-1/2x/b$	$1/2Fx$	0	$-1/4Fx^2/b$	0	$1/4x^2/b^2$			
	totali							$1/4Fb^2/EJ$	$1/2Xb/EJ$
	iperstatica $X=W_{GD}$							$-1/2Fb$	

Sviluppi di calcolo iperstatica

$$L_{FG}^{xx} = \int_0^b (1/4 x^2/b^2) 1/EJ dx = [1/12 x^3/b^2]_0^b 1/EJ$$

$$= (1/12 b) 1/EJ = 1/12 b/EJ$$

$$L_{GF}^{xx} = \int_0^b (1/4 - 1/2 x/b + 1/4 x^2/b^2) 1/EJ dx = [1/4 x - 1/4 x^2/b + 1/12 x^3/b^2]_0^b 1/EJ$$

$$= (1/4 b - 1/4 b + 1/12 b) 1/EJ = 1/12 b/EJ$$

$$L_{GD}^{xx} = \int_0^b (1 - 2 x/b + x^2/b^2) 1/EJ dx = [x - x^2/b + 1/3 x^3/b^2]_0^b 1/EJ$$

$$= (b - b + 1/3 b) 1/EJ = 1/3 b/EJ$$

$$L_{DG}^{xx} = \int_0^b (x^2/b^2) 1/EJ dx = [1/3 x^3/b^2]_0^b 1/EJ$$

$$= (1/3 b) 1/EJ = 1/3 b/EJ$$

$$L_{GA}^{xx} = \int_0^b (1/4 - 1/2 x/b + 1/4 x^2/b^2) 1/EJ dx = [1/4 x - 1/4 x^2/b + 1/12 x^3/b^2]_0^b 1/EJ$$

$$= (1/4 b - 1/4 b + 1/12 b) 1/EJ = 1/12 b/EJ$$

$$L_{AG}^{xx} = \int_0^b (1/4 x^2/b^2) 1/EJ dx = [1/12 x^3/b^2]_0^b 1/EJ$$

$$= (1/12 b) 1/EJ = 1/12 b/EJ$$

$$L_{FG}^{xo} = \int_0^b (-1/2 x/b + 3/4 x^2/b^2) Fb 1/EJ dx + \int_0^b (1/2 x/b) \theta dx$$

$$= [-1/4 x^2/b + 1/4 x^3/b^2]_0^b Fb 1/EJ + [1/4 x^2/b]_0^b \theta$$

$$= (-1/4 b + 1/4 b) Fb 1/EJ + (1/4 b) \theta = 1/4 Fb^2/EJ$$

$$L_{GF}^{xo} = \int_0^b (1/4 - x/b + 3/4 x^2/b^2) Fb 1/EJ dx + \int_0^b (-1/2 + 1/2 x/b) \theta dx$$

$$= [1/4 x - 1/2 x^2/b + 1/4 x^3/b^2]_0^b Fb 1/EJ + [-1/2 x + 1/4 x^2/b]_0^b \theta$$

$$= (1/4 b - 1/2 b + 1/4 b) Fb 1/EJ + (-1/2 b + 1/4 b) \theta = 1/4 Fb^2/EJ$$

$$L_{GD}^{xo} = \int_0^b (1/2 x/b - 1/2 x^2/b^2) Fb 1/EJ dx = [1/4 x^2/b - 1/6 x^3/b^2]_0^b Fb 1/EJ$$

$$= (1/4 b - 1/6 b) Fb 1/EJ = 1/12 Fb^2/EJ$$

$$L_{DG}^{xo} = \int_0^b (1/2 x/b - 1/2 x^2/b^2) Fb 1/EJ dx = [1/4 x^2/b - 1/6 x^3/b^2]_0^b Fb 1/EJ$$

$$= (1/4 b - 1/6 b) Fb 1/EJ = 1/12 Fb^2/EJ$$

$$L_{GA}^{xo} = \int_0^b (-1/4 + 1/2 x/b - 1/4 x^2/b^2) Fb 1/EJ dx = [-1/4 x + 1/4 x^2/b - 1/12 x^3/b^2]_0^b Fb 1/EJ$$

$$= (-1/4 b + 1/4 b - 1/12 b) Fb 1/EJ = -1/12 Fb^2/EJ$$

$$L_{AG}^{xo} = \int_0^b (-1/4 x^2/b^2) Fb 1/EJ dx = [-1/12 x^3/b^2]_0^b Fb 1/EJ$$

$$= (-1/12 b) Fb 1/EJ = -1/12 Fb^2/EJ$$

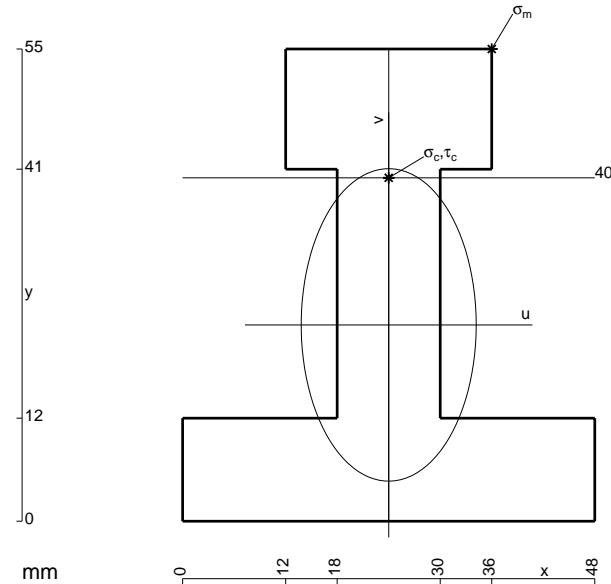

$$A = 1260. \text{ mm}^2$$

$$J_u = 417492. \text{ mm}^4$$

$$J_v = 130896. \text{ mm}^4$$

$$y_g = 22.86 \text{ mm}$$

$$T_y = -3180. \text{ N}$$

$$M_x = -3116400. \text{ Nmm}$$

$$x_m = 36. \text{ mm}$$

$$y_m = 55. \text{ mm}$$

$$u_m = 12. \text{ mm}$$

$$v_m = 32.14 \text{ mm}$$

$$\sigma_m = -Mv/J_u = 239.9 \text{ N/mm}^2$$

$$x_c = 24. \text{ mm}$$

$$y_c = 40. \text{ mm}$$

$$v_c = 17.14 \text{ mm}$$

$$\sigma_c = -Mv/J_u = 127.9 \text{ N/mm}^2$$

$$\tau_c = 5.496 \text{ N/mm}^2$$

$$\sigma_o = \sqrt{\sigma^2 + 3\tau^2} = 128.3 \text{ N/mm}^2$$

$$S = 8658. \text{ mm}^3$$

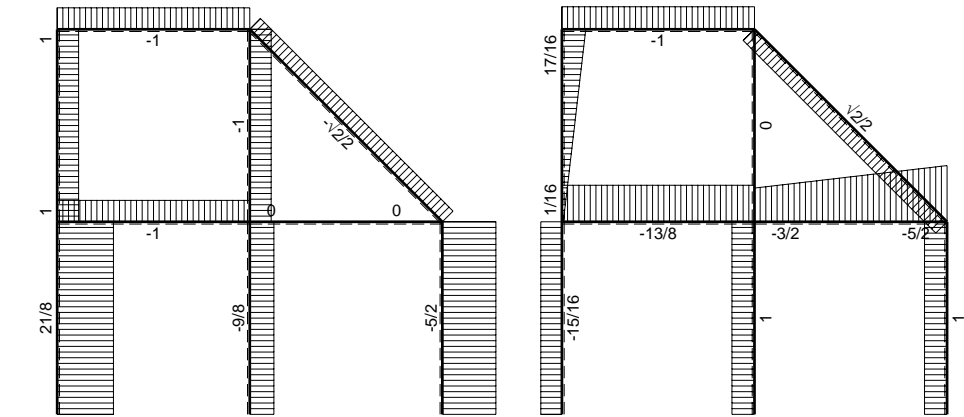
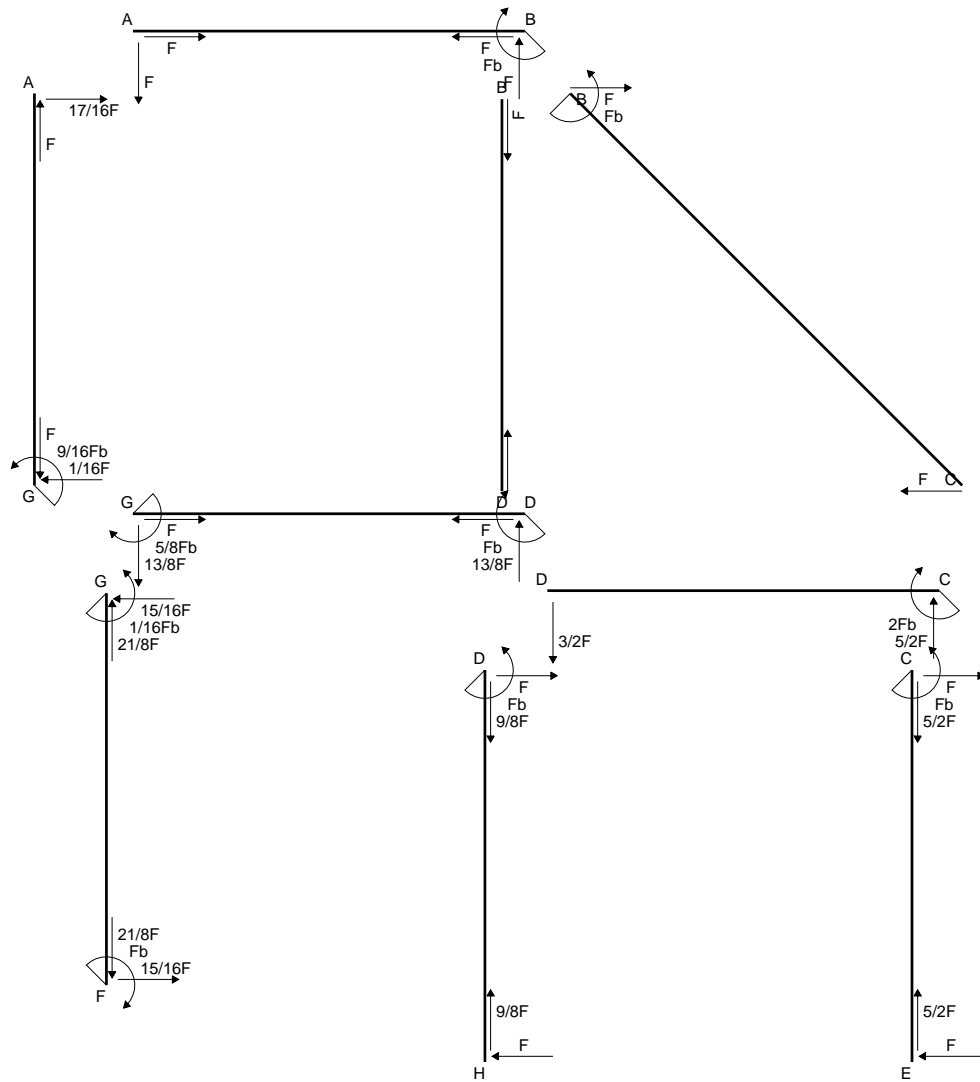

← ⊕ → F

↑ ⊕ ↓ F

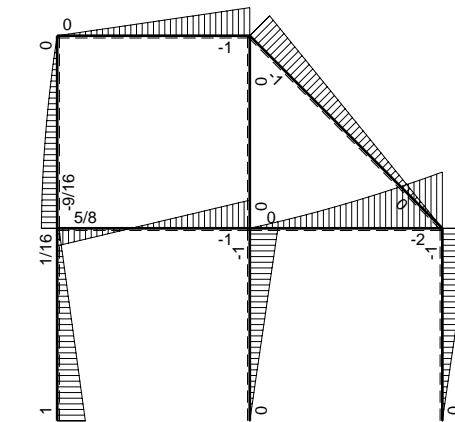

⊕ ⊖ F_b

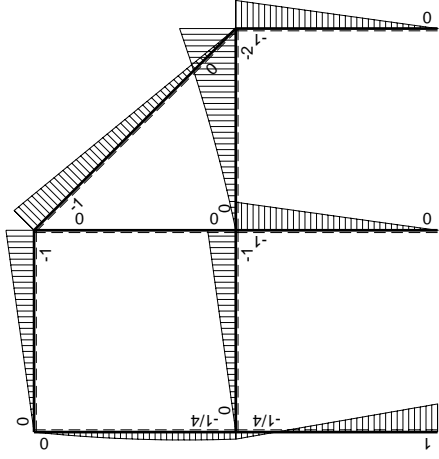
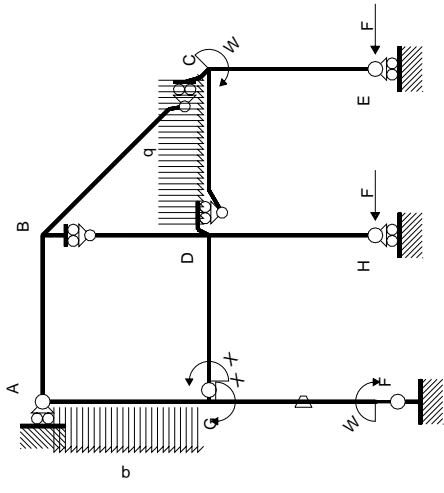

Schema di calcolo iperstatico

M_0 flessione da carichi assegnati



M_x flessione da iperstatica $X=1$

Quadro contributi PLV per iperstatica $X=W_{GD}$

→	$M_x(x)$	$M_o(x)$	θ	$M_x M_o$	$M_x \theta$	$M_x M_x$	$\int M_x(M_o/EJ+\theta)dx$	$\int X M_x M_x/EJ dx$	
AB b	0	-Fx	0	0	0	0	0+0	0	
BA b	0	Fb-Fx	0	0	0	0	0	0	
BC $\sqrt{2}b$	0	-Fb+ $\sqrt{2}/2Fx$	0	0	0	0	0	0	
BD b	0	0	0	0	0	0	0+0	0	
DB b	0	0	0	0	0	0	0	0	
DC b	0	-3/2Fx-1/2qx ²	0	0	0	0	0+0	0	
CD b	0	2Fb-5/2Fx+1/2qx ²	0	0	0	0	0	0	
CE b	0	-Fb+Fx	0	0	0	0	0+0	0	
EC b	0	Fx	0	0	0	0	0	0	
FG b	-1/2x/b	Fb-5/4Fx	-Fb/EJ	-1/2Fx+5/8Fx ² /b	1/2Fx/EJ	1/4x ² /b ²	(-1/24+1/4)Fb ² /EJ	1/12Xb/EJ	
GF b	1/2-1/2x/b	1/4Fb-5/4Fx	Fb/EJ	1/8Fb-3/4Fx+5/8Fx ² /b	1/2Fb/EJ-1/2Fx/EJ	1/4-1/2x/b+1/4x ² /b ²			
GD b	-1+x/b	-Fx	0	Fx-Fx ² /b	0	1-2x/b+x ² /b ²	(1/6+0)Fb ² /EJ	1/3Xb/EJ	
DG b	x/b	Fb-Fx	0	Fx-Fx ² /b	0	x ² /b ²			
DH b	0	-Fb+Fx	0	0	0	0	0+0	0	
HD b	0	Fx	0	0	0	0	0	0	
GA b	1/2-1/2x/b	-1/4Fb-1/4Fx+1/2qx ²	0	-1/8Fb+3/8Fx ² /b-1/4qx ³ /b	0	1/4-1/2x/b+1/4x ² /b ²	(-1/16+0)Fb ² /EJ	1/12Xb/EJ	
AG b	-1/2x/b	3/4Fx-1/2qx ²	0	-3/8Fx ² /b+1/4qx ³ /b	0	1/4x ² /b ²			
	totali							5/16Fb ² /EJ	1/2Xb/EJ
	iperstatica $X=W_{GD}$							-5/8Fb	

Sviluppi di calcolo iperstatica

$$L_{FG}^{xx} = \int_0^b (1/4 x^2/b^2) 1/EJ dx = [1/12 x^3/b^2]_0^b 1/EJ$$

$$= (1/12 b) 1/EJ = 1/12 b/EJ$$

$$L_{GF}^{xx} = \int_0^b (1/4 -1/2 x/b +1/4 x^2/b^2) 1/EJ dx = [1/4 x -1/4 x^2/b +1/12 x^3/b^2]_0^b 1/EJ$$

$$= (1/4 b -1/4 b +1/12 b) 1/EJ = 1/12 b/EJ$$

$$L_{GD}^{xx} = \int_0^b (1 -2 x/b + x^2/b^2) 1/EJ dx = [x - x^2/b +1/3 x^3/b^2]_0^b 1/EJ$$

$$= (b - b +1/3 b) 1/EJ = 1/3 b/EJ$$

$$L_{DG}^{xx} = \int_0^b (x^2/b^2) 1/EJ dx = [1/3 x^3/b^2]_0^b 1/EJ$$

$$= (1/3 b) 1/EJ = 1/3 b/EJ$$

$$L_{GA}^{xx} = \int_0^b (1/4 -1/2 x/b +1/4 x^2/b^2) 1/EJ dx = [1/4 x -1/4 x^2/b +1/12 x^3/b^2]_0^b 1/EJ$$

$$= (1/4 b -1/4 b +1/12 b) 1/EJ = 1/12 b/EJ$$

$$L_{AG}^{xx} = \int_0^b (1/4 x^2/b^2) 1/EJ dx = [1/12 x^3/b^2]_0^b 1/EJ$$

$$= (1/12 b) 1/EJ = 1/12 b/EJ$$

$$L_{FG}^{xo} = \int_0^b (-1/2 x/b +5/8 x^2/b^2) Fb 1/EJ dx + \int_0^b (1/2 x/b) \theta dx$$

$$= [-1/4 x^2/b +5/24 x^3/b^2]_0^b Fb 1/EJ + [1/4 x^2/b]_0^b \theta$$

$$= (-1/4 b +5/24 b) Fb 1/EJ + (1/4 b) \theta = 5/24 Fb^2/EJ$$

$$L_{GF}^{xo} = \int_0^b (1/8 -3/4 x/b +5/8 x^2/b^2) Fb 1/EJ dx + \int_0^b (-1/2 +1/2 x/b) \theta dx$$

$$= [1/8 x -3/8 x^2/b +5/24 x^3/b^2]_0^b Fb 1/EJ + [-1/2 x +1/4 x^2/b]_0^b \theta$$

$$= (1/8 b -3/8 b +5/24 b) Fb 1/EJ + (-1/2 b +1/4 b) \theta = 5/24 Fb^2/EJ$$

$$L_{GD}^{xo} = \int_0^b (x/b - x^2/b^2) Fb 1/EJ dx = [1/2 x^2/b -1/3 x^3/b^2]_0^b Fb 1/EJ$$

$$= (1/2 b -1/3 b) Fb 1/EJ = 1/6 Fb^2/EJ$$

$$L_{DG}^{xo} = \int_0^b (x/b - x^2/b^2) Fb 1/EJ dx = [1/2 x^2/b -1/3 x^3/b^2]_0^b Fb 1/EJ$$

$$= (1/2 b -1/3 b) Fb 1/EJ = 1/6 Fb^2/EJ$$

$$L_{GA}^{xo} = \int_0^b (-1/8 +3/8 x^2/b^2 -1/4 x^3/b^3) Fb 1/EJ dx = [-1/8 x +1/8 x^3/b^2 -1/16 x^4/b^3]_0^b Fb 1/EJ$$

$$= (-1/8 b +1/8 b -1/16 b) Fb 1/EJ = -1/16 Fb^2/EJ$$

$$L_{AG}^{xo} = \int_0^b (-3/8 x^2/b^2 +1/4 x^3/b^3) Fb 1/EJ dx = [-1/8 x^3/b^2 +1/16 x^4/b^3]_0^b Fb 1/EJ$$

$$= (-1/8 b +1/16 b) Fb 1/EJ = -1/16 Fb^2/EJ$$

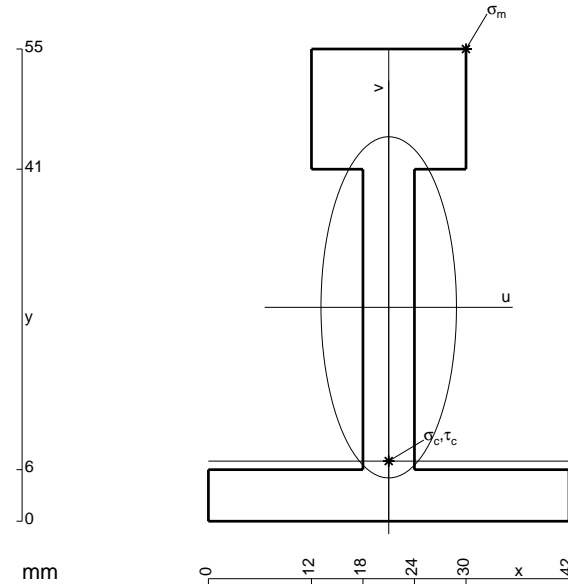

- A = 714. mm²
- J_u = 282052. mm⁴
- J_v = 44478. mm⁴
- y_g = 24.91 mm
- T_y = -4500. N
- M_x = -1872000. Nmm
- x_m = 30. mm
- y_m = 55. mm
- u_m = 9. mm
- v_m = 30.09 mm
- σ_m = -Mv/J_u = 199.7 N/mm²
- x_c = 21. mm
- y_c = 7. mm
- v_c = -17.91 mm
- σ_c = -Mv/J_u = -118.9 N/mm²
- τ_c = 14.98 N/mm²
- σ_o = √σ²+3τ² = 121.7 N/mm²
- S = 5632. mm³

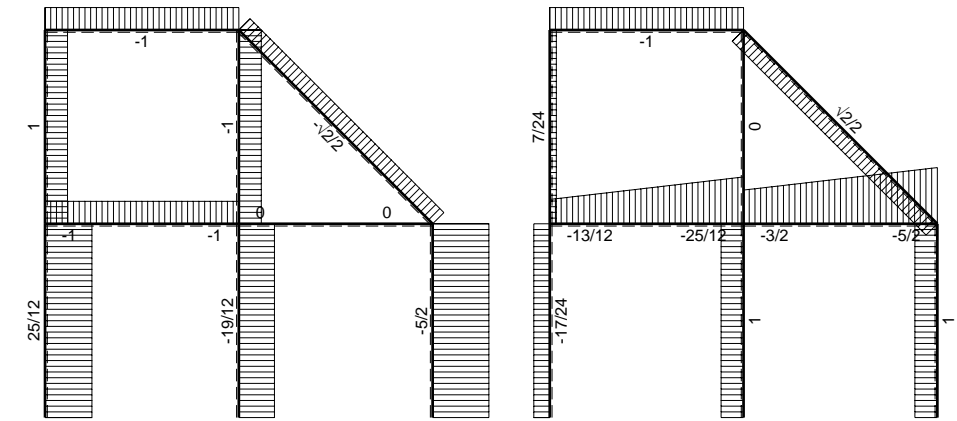
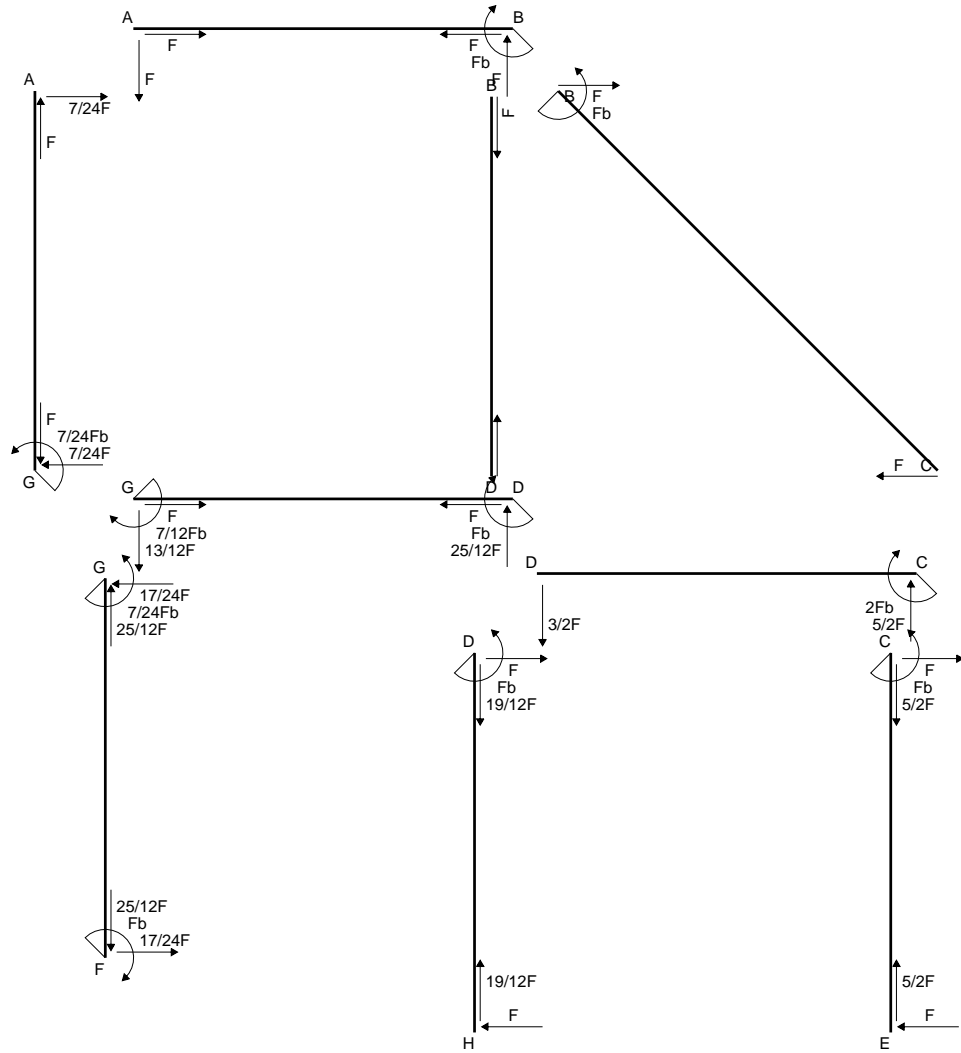

← ⊕ → F

↑ ⊕ ↓ F_b

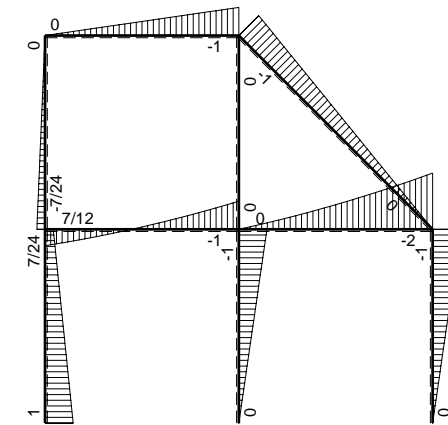

⊕ ⊖ F_b

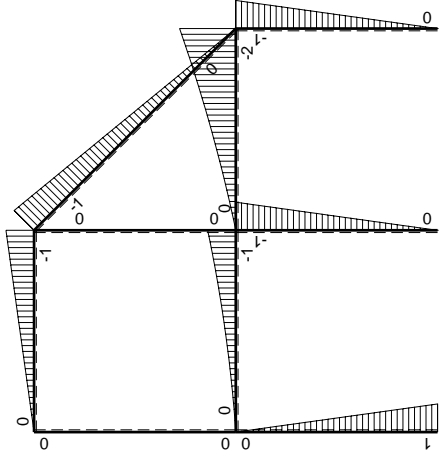
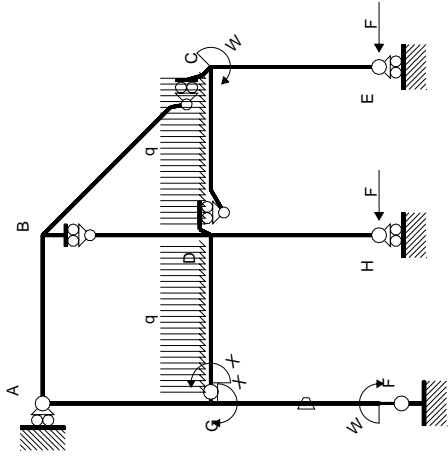

Schema di calcolo iperstatico

M_0 flessione da carichi assegnati

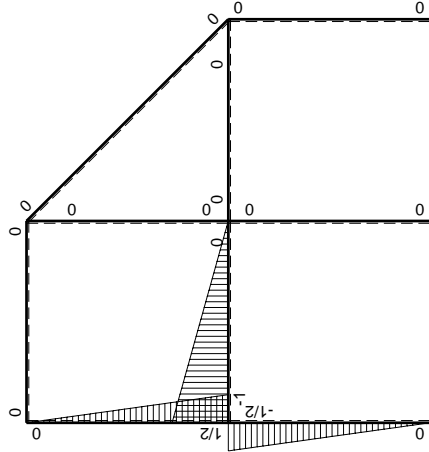

M_x flessione da iperstatica $X=1$

Quadro contributi PLV per iperstatica $X=W_{GD}$

→	$M_x(x)$	$M_o(x)$	θ	$M_x M_o$	$M_x \theta$	$M_x M_x$	$\int M_x(M_o/EJ+\theta)dx$	$\int X M_x M_x/EJ dx$	
AB b	0	-Fx	0	0	0	0	0+0	0	
BA b	0	Fb-Fx	0	0	0	0	0	0	
BC $\sqrt{2}b$	0	-Fb+ $\sqrt{2}/2Fx$	0	0	0	0	0	0	
BD b	0	0	0	0	0	0	0+0	0	
DB b	0	0	0	0	0	0	0	0	
DC b	0	-3/2Fx-1/2qx ²	0	0	0	0	0+0	0	
CD b	0	2Fb-5/2Fx+1/2qx ²	0	0	0	0	0	0	
CE b	0	-Fb+Fx	0	0	0	0	0+0	0	
EC b	0	Fx	0	0	0	0	0	0	
FG b	-1/2x/b	Fb-Fx	-Fb/EJ	-1/2Fx+1/2Fx ² /b	1/2Fx/EJ	1/4x ² /b ²	(-1/12+1/4)Fb ² /EJ	1/12Xb/EJ	
GF b	1/2-1/2x/b	-Fx	Fb/EJ	-1/2Fx+1/2Fx ² /b	1/2Fb/EJ-1/2Fx/EJ	1/4-1/2x/b+1/4x ² /b ²			
GD b	-1+x/b	-1/2Fx-1/2qx ²	0	1/2Fx-1/2qx ³ /b	0	1-2x/b+x ² /b ²	(1/8+0)Fb ² /EJ	1/3Xb/EJ	
DG b	x/b	Fb-3/2Fx+1/2qx ²	0	Fx-3/2Fx ² /b+1/2qx ³ /b	0	x ² /b ²			
DH b	0	-Fb+Fx	0	0	0	0	0+0	0	
HD b	0	Fx	0	0	0	0	0	0	
GA b	1/2-1/2x/b	0	0	0	0	1/4-1/2x/b+1/4x ² /b ²	0+0	1/12Xb/EJ	
AG b	-1/2x/b	0	0	0	0	1/4x ² /b ²			
	totali							7/24Fb ² /EJ	1/2Xb/EJ
	iperstatica $X=W_{GD}$							-7/12Fb	

Sviluppi di calcolo iperstatica

$$L_{FG}^{xx} = \int_0^b (1/4 x^2/b^2) 1/EJ dx = [1/12 x^3/b^2]_0^b 1/EJ$$

$$= (1/12 b) 1/EJ = 1/12 b/EJ$$

$$L_{GF}^{xx} = \int_0^b (1/4 - 1/2 x/b + 1/4 x^2/b^2) 1/EJ dx = [1/4 x - 1/4 x^2/b + 1/12 x^3/b^2]_0^b 1/EJ$$

$$= (1/4 b - 1/4 b + 1/12 b) 1/EJ = 1/12 b/EJ$$

$$L_{GD}^{xx} = \int_0^b (1 - 2 x/b + x^2/b^2) 1/EJ dx = [x - x^2/b + 1/3 x^3/b^2]_0^b 1/EJ$$

$$= (b - b + 1/3 b) 1/EJ = 1/3 b/EJ$$

$$L_{DG}^{xx} = \int_0^b (x^2/b^2) 1/EJ dx = [1/3 x^3/b^2]_0^b 1/EJ$$

$$= (1/3 b) 1/EJ = 1/3 b/EJ$$

$$L_{GA}^{xx} = \int_0^b (1/4 - 1/2 x/b + 1/4 x^2/b^2) 1/EJ dx = [1/4 x - 1/4 x^2/b + 1/12 x^3/b^2]_0^b 1/EJ$$

$$= (1/4 b - 1/4 b + 1/12 b) 1/EJ = 1/12 b/EJ$$

$$L_{AG}^{xx} = \int_0^b (1/4 x^2/b^2) 1/EJ dx = [1/12 x^3/b^2]_0^b 1/EJ$$

$$= (1/12 b) 1/EJ = 1/12 b/EJ$$

$$L_{FG}^{xo} = \int_0^b (-1/2 x/b + 1/2 x^2/b^2) Fb 1/EJ dx + \int_0^b (1/2 x/b) \theta dx$$

$$= [-1/4 x^2/b + 1/6 x^3/b^2]_0^b Fb 1/EJ + [1/4 x^2/b]_0^b \theta$$

$$= (-1/4 b + 1/6 b) Fb 1/EJ + (1/4 b) \theta = 1/6 Fb^2/EJ$$

$$L_{GF}^{xo} = \int_0^b (-1/2 x/b + 1/2 x^2/b^2) Fb 1/EJ dx + \int_0^b (-1/2 + 1/2 x/b) \theta dx$$

$$= [-1/4 x^2/b + 1/6 x^3/b^2]_0^b Fb 1/EJ + [-1/2 x + 1/4 x^2/b]_0^b \theta$$

$$= (-1/4 b + 1/6 b) Fb 1/EJ + (-1/2 b + 1/4 b) \theta = 1/6 Fb^2/EJ$$

$$L_{GD}^{xo} = \int_0^b (1/2 x/b - 1/2 x^3/b^3) Fb 1/EJ dx = [1/4 x^2/b - 1/8 x^4/b^3]_0^b Fb 1/EJ$$

$$= (1/4 b - 1/8 b) Fb 1/EJ = 1/8 Fb^2/EJ$$

$$L_{DG}^{xo} = \int_0^b (x/b - 3/2 x^2/b^2 + 1/2 x^3/b^3) Fb 1/EJ dx = [1/2 x^2/b - 1/2 x^3/b^2 + 1/8 x^4/b^3]_0^b Fb 1/EJ$$

$$= (1/2 b - 1/2 b + 1/8 b) Fb 1/EJ = 1/8 Fb^2/EJ$$

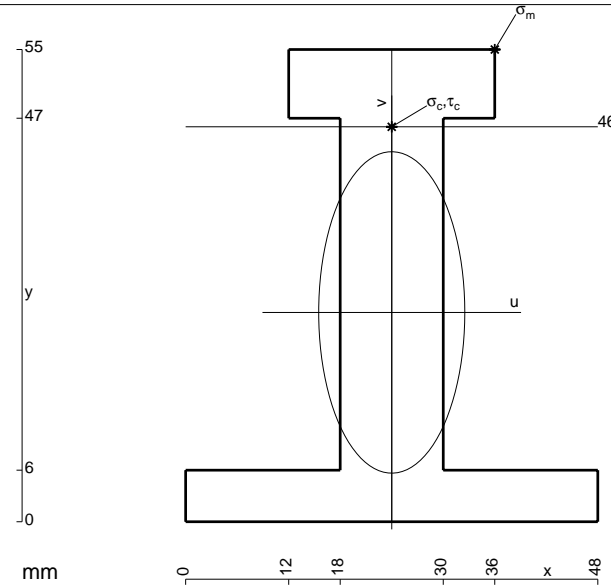

- A = 972. mm²
- J_u = 340722. mm⁴
- J_v = 70416. mm⁴
- y_g = 24.38 mm
- T_y = -5100. N
- M_x = -2325600. Nmm
- x_m = 36. mm
- y_m = 55. mm
- u_m = 12. mm
- v_m = 30.62 mm
- σ_m = -Mv/J_u = 209. N/mm²
- x_c = 24. mm
- y_c = 46. mm
- v_c = 21.62 mm
- σ_c = -Mv/J_u = 147.6 N/mm²
- τ_c = 6.707 N/mm²
- σ_φ = √(σ²+3τ²) = 148. N/mm²
- S = 5377. mm³

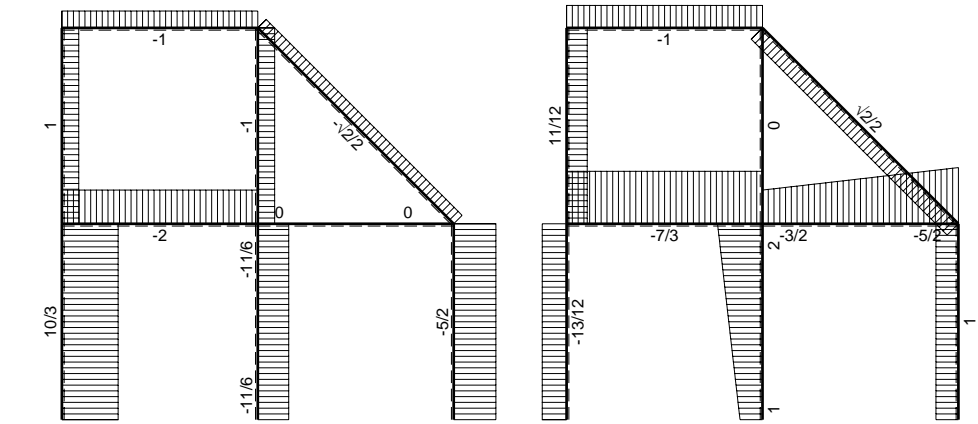
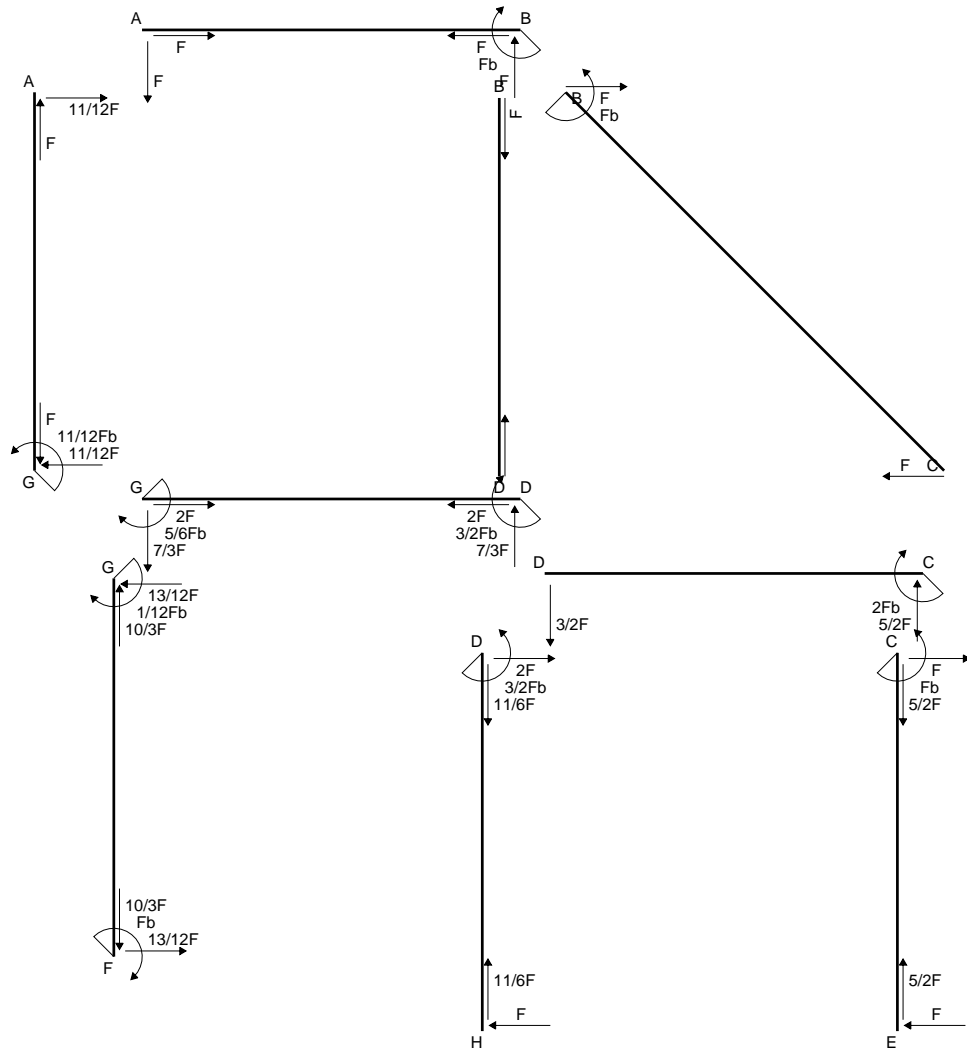

← ⊕ → F

↑ ⊕ ↓ F_b

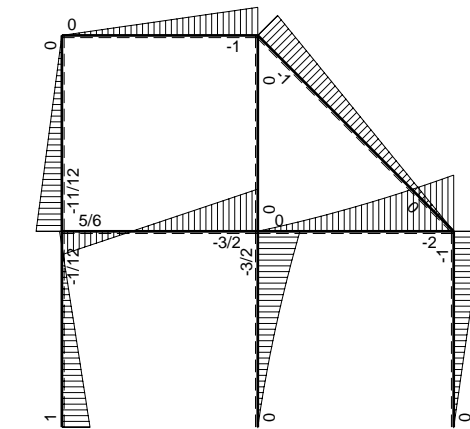

⊕ ⊖ F_b

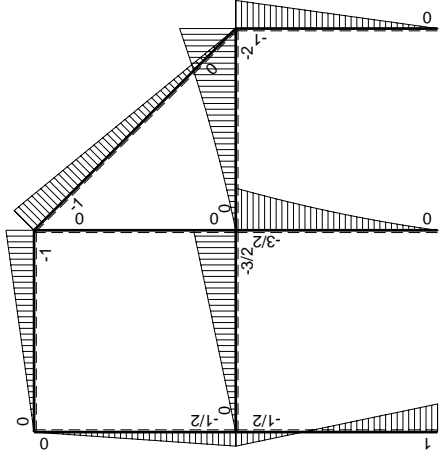
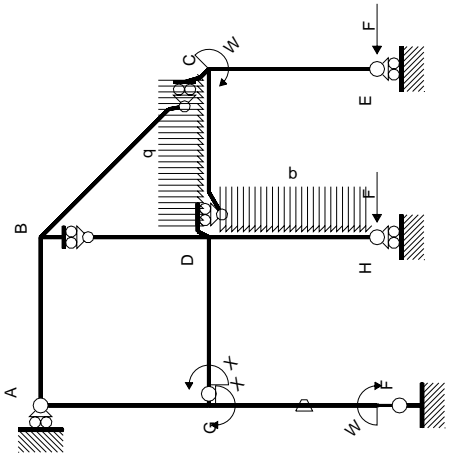

Schema di calcolo iperstatico

M_0 flessione da carichi assegnati

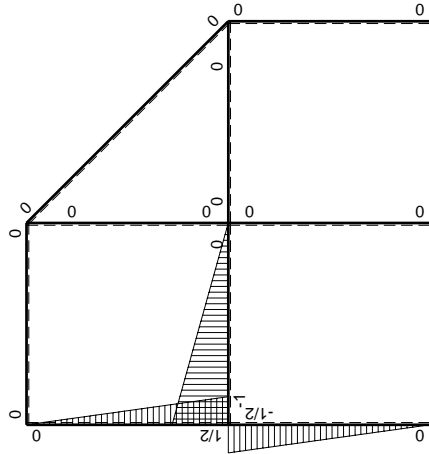

M_x flessione da iperstatica $X=1$

Quadro contributi PLV per iperstatica $X=W_{GD}$

→	$M_x(x)$	$M_o(x)$	θ	$M_x M_o$	$M_x \theta$	$M_x M_x$	$\int M_x(M_o/EJ+\theta)dx$	$\int X M_x M_x/EJdx$
AB b	0	-Fx	0	0	0	0	0+0	0
BA b	0	Fb-Fx	0	0	0	0	0	0
BC $\sqrt{2}b$	0	-Fb+ $\sqrt{2}/2Fx$	0	0	0	0	0	0
BD b	0	0	0	0	0	0	0+0	0
DB b	0	0	0	0	0	0	0	0
DC b	0	-3/2Fx-1/2qx ²	0	0	0	0	0+0	0
CD b	0	2Fb-5/2Fx+1/2qx ²	0	0	0	0	0	0
CE b	0	-Fb+Fx	0	0	0	0	0+0	0
EC b	0	Fx	0	0	0	0	0	0
FG b	-1/2x/b	Fb-3/2Fx	-Fb/EJ	-1/2Fx+3/4Fx ² /b	1/2Fx/EJ	1/4x ² /b ²	(0+1/4)Fb ² /EJ	1/12Xb/EJ
GF b	1/2-1/2x/b	1/2Fb-3/2Fx	Fb/EJ	1/4Fb-Fx+3/4Fx ² /b	1/2Fb/EJ-1/2Fx/EJ	1/4-1/2x/b+1/4x ² /b ²		
GD b	-1+x/b	-3/2Fx	0	3/2Fx-3/2Fx ² /b	0	1-2x/b+x ² /b ²	(1/4+0)Fb ² /EJ	1/3Xb/EJ
DG b	x/b	3/2Fb-3/2Fx	0	3/2Fx-3/2Fx ² /b	0	x ² /b ²		
DH b	0	-3/2Fb+2Fx-1/2qx ²	0	0	0	0	0+0	0
HD b	0	Fx+1/2qx ²	0	0	0	0	0	0
GA b	1/2-1/2x/b	-1/2Fb+1/2Fx	0	-1/4Fb+1/2Fx-1/4Fx ² /b	0	1/4-1/2x/b+1/4x ² /b ²	(-1/12+0)Fb ² /EJ	1/12Xb/EJ
AG b	-1/2x/b	1/2Fx	0	-1/4Fx ² /b	0	1/4x ² /b ²		
	totali						5/12Fb ² /EJ	1/2Xb/EJ
	iperstatica $X=W_{GD}$						-5/6Fb	

Sviluppi di calcolo iperstatica

$$L_{FG}^{xx} = \int_0^b (1/4 x^2/b^2) 1/EJ dx = [1/12 x^3/b^2]_0^b 1/EJ$$

$$= (1/12 b) 1/EJ = 1/12 b/EJ$$

$$L_{GF}^{xx} = \int_0^b (1/4 - 1/2 x/b + 1/4 x^2/b^2) 1/EJ dx = [1/4 x - 1/4 x^2/b + 1/12 x^3/b^2]_0^b 1/EJ$$

$$= (1/4 b - 1/4 b + 1/12 b) 1/EJ = 1/12 b/EJ$$

$$L_{GD}^{xx} = \int_0^b (1 - 2 x/b + x^2/b^2) 1/EJ dx = [x - x^2/b + 1/3 x^3/b^2]_0^b 1/EJ$$

$$= (b - b + 1/3 b) 1/EJ = 1/3 b/EJ$$

$$L_{DG}^{xx} = \int_0^b (x^2/b^2) 1/EJ dx = [1/3 x^3/b^2]_0^b 1/EJ$$

$$= (1/3 b) 1/EJ = 1/3 b/EJ$$

$$L_{GA}^{xx} = \int_0^b (1/4 - 1/2 x/b + 1/4 x^2/b^2) 1/EJ dx = [1/4 x - 1/4 x^2/b + 1/12 x^3/b^2]_0^b 1/EJ$$

$$= (1/4 b - 1/4 b + 1/12 b) 1/EJ = 1/12 b/EJ$$

$$L_{AG}^{xx} = \int_0^b (1/4 x^2/b^2) 1/EJ dx = [1/12 x^3/b^2]_0^b 1/EJ$$

$$= (1/12 b) 1/EJ = 1/12 b/EJ$$

$$L_{FG}^{xo} = \int_0^b (-1/2 x/b + 3/4 x^2/b^2) Fb 1/EJ dx + \int_0^b (1/2 x/b) \theta dx$$

$$= [-1/4 x^2/b + 1/4 x^3/b^2]_0^b Fb 1/EJ + [1/4 x^2/b]_0^b \theta$$

$$= (-1/4 b + 1/4 b) Fb 1/EJ + (1/4 b) \theta = 1/4 Fb^2/EJ$$

$$L_{GF}^{xo} = \int_0^b (1/4 - x/b + 3/4 x^2/b^2) Fb 1/EJ dx + \int_0^b (-1/2 + 1/2 x/b) \theta dx$$

$$= [1/4 x - 1/2 x^2/b + 1/4 x^3/b^2]_0^b Fb 1/EJ + [-1/2 x + 1/4 x^2/b]_0^b \theta$$

$$= (1/4 b - 1/2 b + 1/4 b) Fb 1/EJ + (-1/2 b + 1/4 b) \theta = 1/4 Fb^2/EJ$$

$$L_{GD}^{xo} = \int_0^b (3/2 x/b - 3/2 x^2/b^2) Fb 1/EJ dx = [3/4 x^2/b - 1/2 x^3/b^2]_0^b Fb 1/EJ$$

$$= (3/4 b - 1/2 b) Fb 1/EJ = 1/4 Fb^2/EJ$$

$$L_{DG}^{xo} = \int_0^b (3/2 x/b - 3/2 x^2/b^2) Fb 1/EJ dx = [3/4 x^2/b - 1/2 x^3/b^2]_0^b Fb 1/EJ$$

$$= (3/4 b - 1/2 b) Fb 1/EJ = 1/4 Fb^2/EJ$$

$$L_{GA}^{xo} = \int_0^b (-1/4 + 1/2 x/b - 1/4 x^2/b^2) Fb 1/EJ dx = [-1/4 x + 1/4 x^2/b - 1/12 x^3/b^2]_0^b Fb 1/EJ$$

$$= (-1/4 b + 1/4 b - 1/12 b) Fb 1/EJ = -1/12 Fb^2/EJ$$

$$L_{AG}^{xo} = \int_0^b (-1/4 x^2/b^2) Fb 1/EJ dx = [-1/12 x^3/b^2]_0^b Fb 1/EJ$$

$$= (-1/12 b) Fb 1/EJ = -1/12 Fb^2/EJ$$

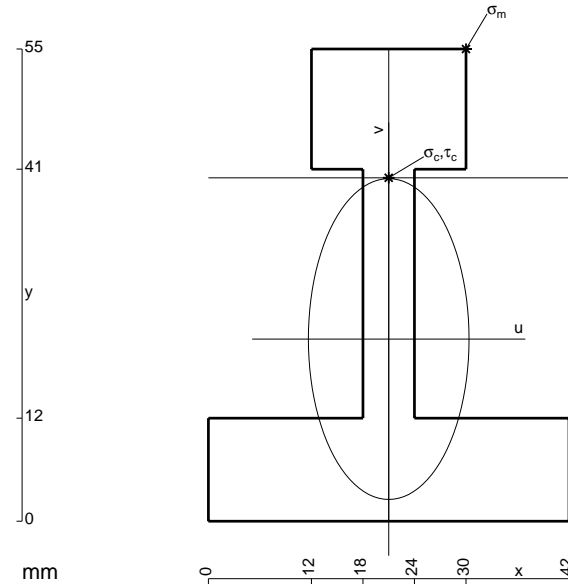

- A = 930. mm²
- J_u = 324687. mm⁴
- J_v = 81414. mm⁴
- y_g = 21.22 mm
- T_y = -4250. N
- M_x = -2108000. Nmm
- x_m = 30. mm
- y_m = 55. mm
- u_m = 9. mm
- v_m = 33.78 mm
- σ_m = -Mv/J_u = 219.3 N/mm²
- x_c = 21. mm
- y_c = 40. mm
- v_c = 18.78 mm
- σ_c = -Mv/J_v = 122. N/mm²
- τ_c = 14.98 N/mm²
- σ_o = √σ²+3τ² = 124.7 N/mm²
- S = 6865. mm³

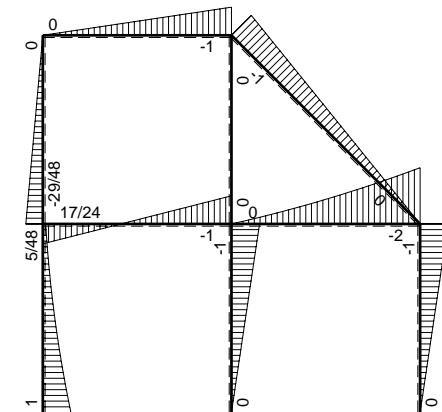
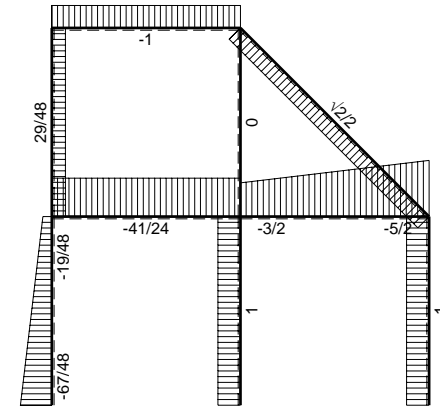
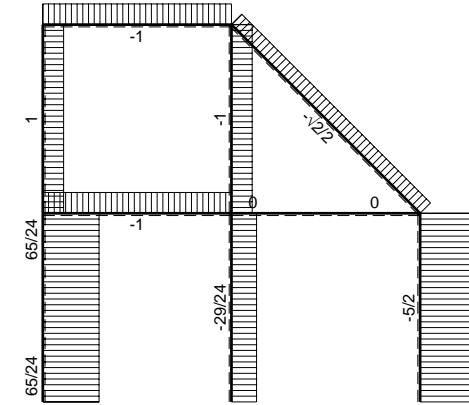
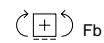
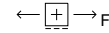
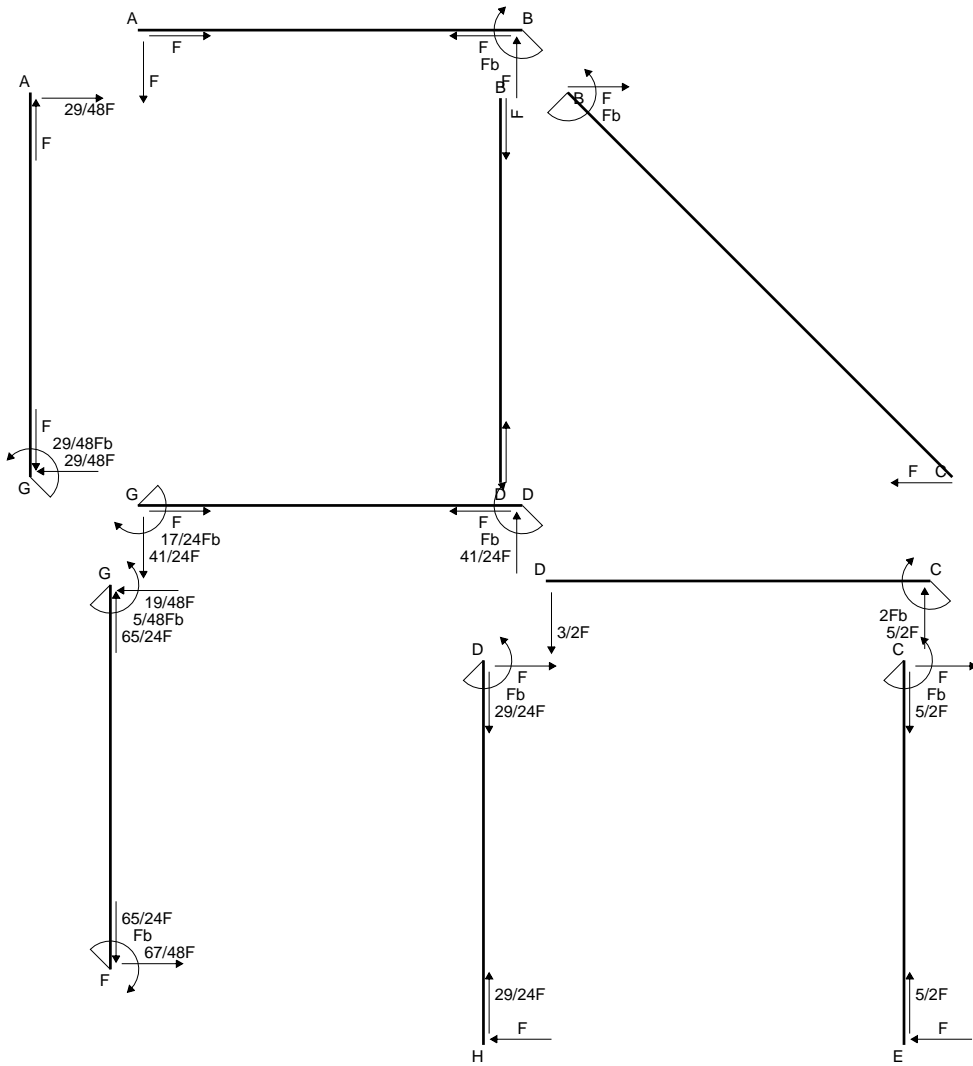

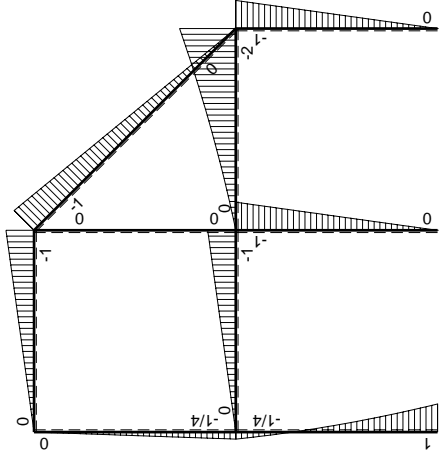
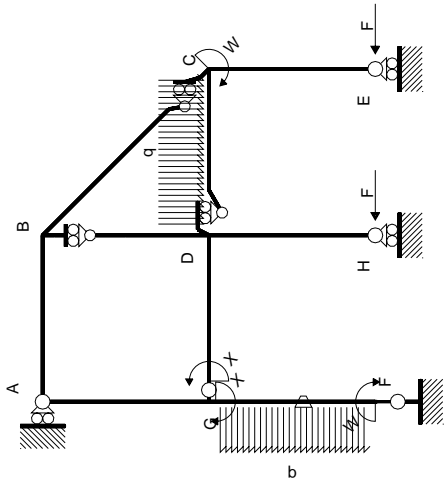

Schema di calcolo iperstatico

M_0 flessione da carichi assegnati

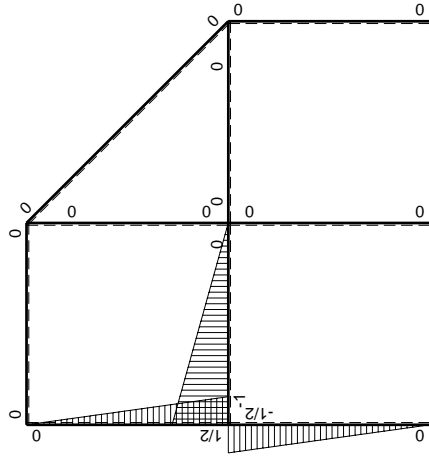

M_x flessione da iperstatica $X=1$

Quadro contributi PLV per iperstatica $X=W_{GD}$

→	$M_x(x)$	$M_o(x)$	θ	$M_x M_o$	$M_x \theta$	$M_x M_x$	$\int M_x(M_o/EJ+\theta)dx$	$\int X M_x M_x/EJ dx$	
AB b	0	-Fx	0	0	0	0	0+0	0	
BA b	0	Fb-Fx	0	0	0	0	0	0	
BC $\sqrt{2}b$	0	-Fb+ $\sqrt{2}/2Fx$	0	0	0	0	0	0	
BD b	0	0	0	0	0	0	0+0	0	
DB b	0	0	0	0	0	0	0	0	
DC b	0	-3/2Fx-1/2qx ²	0	0	0	0	0+0	0	
CD b	0	2Fb-5/2Fx+1/2qx ²	0	0	0	0	0	0	
CE b	0	-Fb+Fx	0	0	0	0	0+0	0	
EC b	0	Fx	0	0	0	0	0	0	
FG b	-1/2x/b	Fb-7/4Fx+1/2qx ²	-Fb/EJ	-1/2Fx+7/8Fx ² /b-1/4qx ³ /b	1/2Fx/EJ	1/4x ² /b ²	(-1/48+1/4)Fb ² /EJ	1/12Xb/EJ	
GF b	1/2-1/2x/b	1/4Fb-3/4Fx-1/2qx ²	Fb/EJ	1/8Fb-1/2Fx+1/8Fx ² /b+1/4qx ³ /b	1/2Fb/EJ-1/2Fx/EJ	1/4-1/2x/b+1/4x ² /b ²			
GD b	-1+x/b	-Fx	0	Fx-Fx ² /b	0	1-2x/b+x ² /b ²	(1/6+0)Fb ² /EJ	1/3Xb/EJ	
DG b	x/b	Fb-Fx	0	Fx-Fx ² /b	0	x ² /b ²			
DH b	0	-Fb+Fx	0	0	0	0	0+0	0	
HD b	0	Fx	0	0	0	0	0	0	
GA b	1/2-1/2x/b	-1/4Fb+1/4Fx	0	-1/8Fb+1/4Fx-1/8Fx ² /b	0	1/4-1/2x/b+1/4x ² /b ²	(-1/24+0)Fb ² /EJ	1/12Xb/EJ	
AG b	-1/2x/b	1/4Fx	0	-1/8Fx ² /b	0	1/4x ² /b ²			
	totali							17/48Fb ² /EJ	1/2Xb/EJ
	iperstatica $X=W_{GD}$							-17/24Fb	

Sviluppi di calcolo iperstatica

$$L_{FG}^{xx} = \int_0^b (1/4 x^2/b^2) 1/EJ dx = [1/12 x^3/b^2]_0^b 1/EJ$$

$$= (1/12 b) 1/EJ = 1/12 b/EJ$$

$$L_{GF}^{xx} = \int_0^b (1/4 - 1/2 x/b + 1/4 x^2/b^2) 1/EJ dx = [1/4 x - 1/4 x^2/b + 1/12 x^3/b^2]_0^b 1/EJ$$

$$= (1/4 b - 1/4 b + 1/12 b) 1/EJ = 1/12 b/EJ$$

$$L_{GD}^{xx} = \int_0^b (1 - 2 x/b + x^2/b^2) 1/EJ dx = [x - x^2/b + 1/3 x^3/b^2]_0^b 1/EJ$$

$$= (b - b + 1/3 b) 1/EJ = 1/3 b/EJ$$

$$L_{DG}^{xx} = \int_0^b (x^2/b^2) 1/EJ dx = [1/3 x^3/b^2]_0^b 1/EJ$$

$$= (1/3 b) 1/EJ = 1/3 b/EJ$$

$$L_{GA}^{xx} = \int_0^b (1/4 - 1/2 x/b + 1/4 x^2/b^2) 1/EJ dx = [1/4 x - 1/4 x^2/b + 1/12 x^3/b^2]_0^b 1/EJ$$

$$= (1/4 b - 1/4 b + 1/12 b) 1/EJ = 1/12 b/EJ$$

$$L_{AG}^{xx} = \int_0^b (1/4 x^2/b^2) 1/EJ dx = [1/12 x^3/b^2]_0^b 1/EJ$$

$$= (1/12 b) 1/EJ = 1/12 b/EJ$$

$$L_{FG}^{xo} = \int_0^b (-1/2 x/b + 7/8 x^2/b^2 - 1/4 x^3/b^3) Fb 1/EJ dx + \int_0^b (1/2 x/b) \theta dx$$

$$= [-1/4 x^2/b + 7/24 x^3/b^2 - 1/16 x^4/b^3]_0^b Fb 1/EJ + [1/4 x^2/b]_0^b \theta$$

$$= (-1/4 b + 7/24 b - 1/16 b) Fb 1/EJ + (1/4 b) \theta = 11/48 Fb^2/EJ$$

$$L_{GF}^{xo} = \int_0^b (1/8 - 1/2 x/b + 1/8 x^2/b^2 + 1/4 x^3/b^3) Fb 1/EJ dx + \int_0^b (-1/2 + 1/2 x/b) \theta dx$$

$$= [1/8 x - 1/4 x^2/b + 1/24 x^3/b^2 + 1/16 x^4/b^3]_0^b Fb 1/EJ + [-1/2 x + 1/4 x^2/b]_0^b \theta$$

$$= (1/8 b - 1/4 b + 1/24 b + 1/16 b) Fb 1/EJ + (-1/2 b + 1/4 b) \theta = 11/48 Fb^2/EJ$$

$$L_{GD}^{xo} = \int_0^b (x/b - x^2/b^2) Fb 1/EJ dx = [1/2 x^2/b - 1/3 x^3/b^2]_0^b Fb 1/EJ$$

$$= (1/2 b - 1/3 b) Fb 1/EJ = 1/6 Fb^2/EJ$$

$$L_{DG}^{xo} = \int_0^b (x/b - x^2/b^2) Fb 1/EJ dx = [1/2 x^2/b - 1/3 x^3/b^2]_0^b Fb 1/EJ$$

$$= (1/2 b - 1/3 b) Fb 1/EJ = 1/6 Fb^2/EJ$$

$$L_{GA}^{xo} = \int_0^b (-1/8 + 1/4 x/b - 1/8 x^2/b^2) Fb 1/EJ dx = [-1/8 x + 1/8 x^2/b - 1/24 x^3/b^2]_0^b Fb 1/EJ$$

$$= (-1/8 b + 1/8 b - 1/24 b) Fb 1/EJ = -1/24 Fb^2/EJ$$

$$L_{AG}^{xo} = \int_0^b (-1/8 x^2/b^2) Fb 1/EJ dx = [-1/24 x^3/b^2]_0^b Fb 1/EJ$$

$$= (-1/24 b) Fb 1/EJ = -1/24 Fb^2/EJ$$

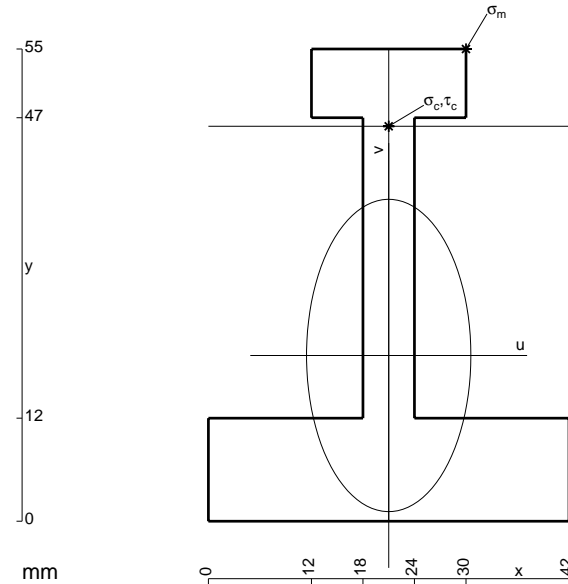

$$A = 858. \text{ mm}^2$$

$$J_u = 283959. \text{ mm}^4$$

$$J_v = 78606. \text{ mm}^4$$

$$y_g = 19.3 \text{ mm}$$

$$T_y = -3400. \text{ N}$$

$$M_x = -1822400. \text{ Nmm}$$

$$x_m = 30. \text{ mm}$$

$$y_m = 55. \text{ mm}$$

$$u_m = 9. \text{ mm}$$

$$v_m = 35.7 \text{ mm}$$

$$\sigma_m = -Mv/J_u = 229.1 \text{ N/mm}^2$$

$$x_c = 21. \text{ mm}$$

$$y_c = 46. \text{ mm}$$

$$v_c = 26.7 \text{ mm}$$

$$\sigma_c = -Mv/J_u = 171.3 \text{ N/mm}^2$$

$$\tau_c = 9.434 \text{ N/mm}^2$$

$$\sigma_o = \sqrt{\sigma^2 + 3\tau^2} = 172.1 \text{ N/mm}^2$$

$$S = 4727. \text{ mm}^3$$

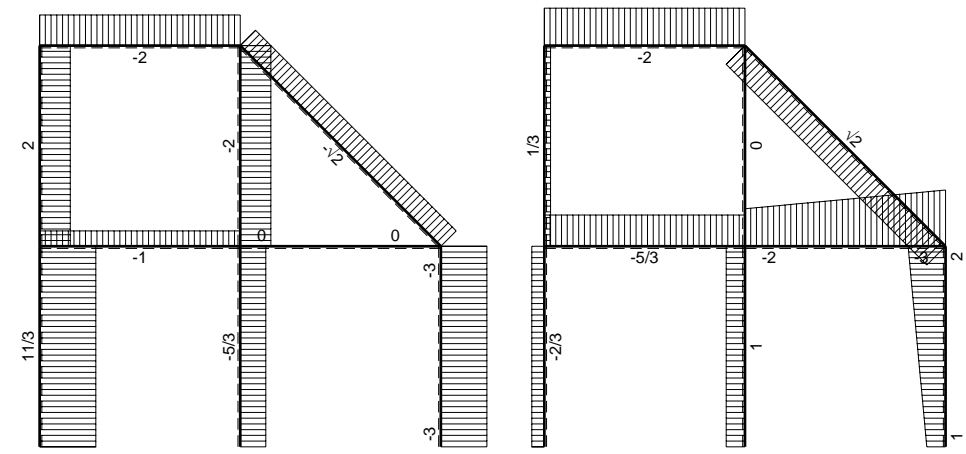
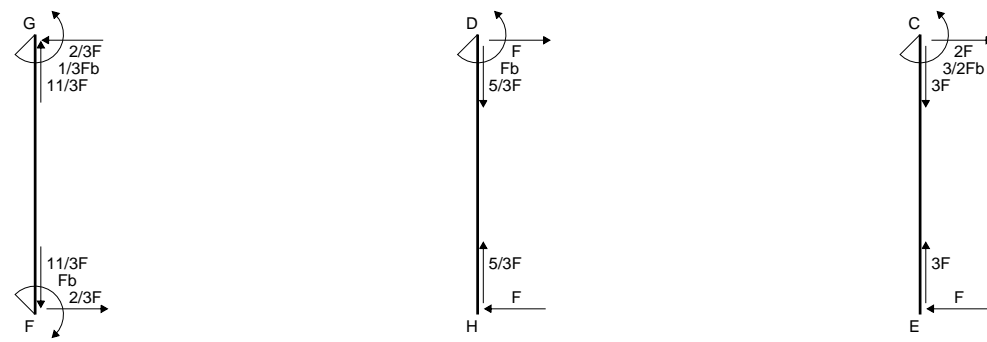
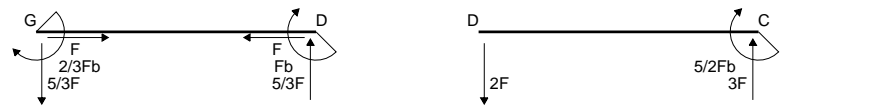
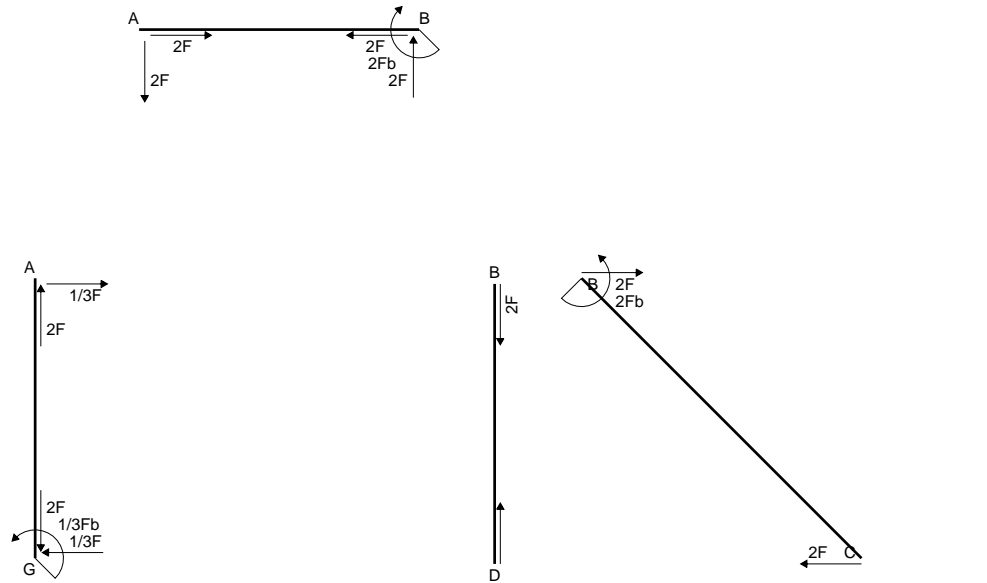

← ⊕ → F

↑ ⊕ ↓ Fb

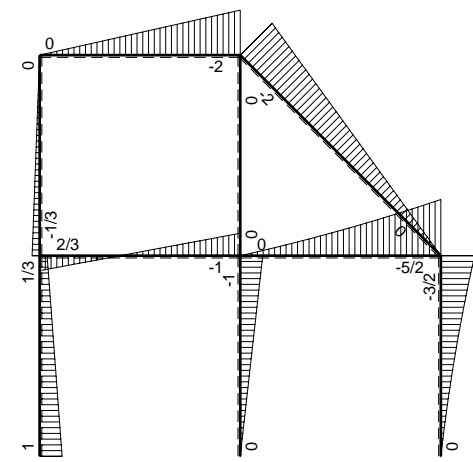

← ⊕ → Fb

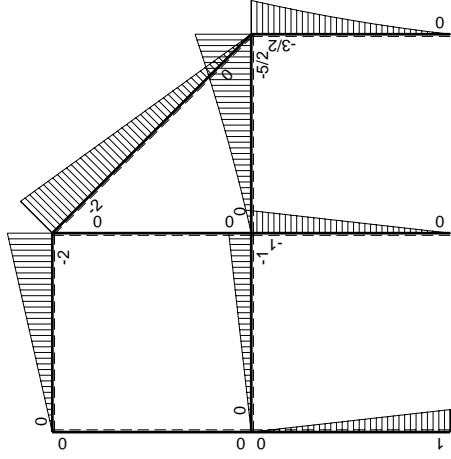
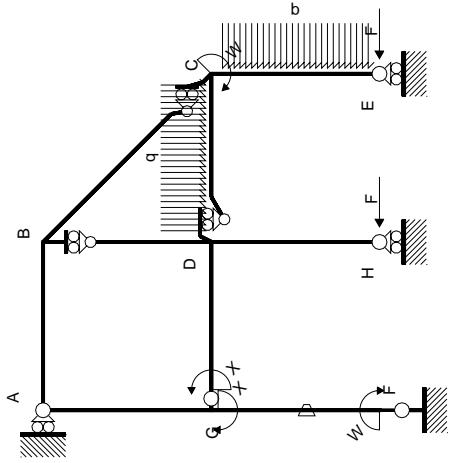

Schema di calcolo iperstatico

M_0 flessione da carichi assegnati

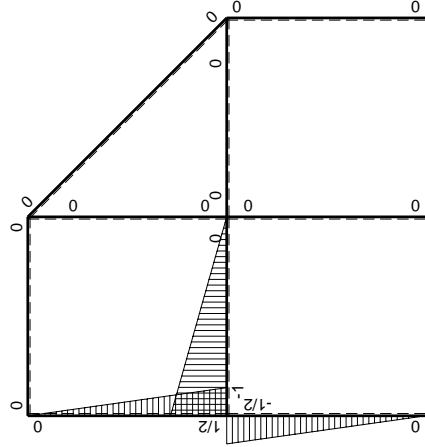

M_x flessione da iperstatica $X=1$

Quadro contributi PLV per iperstatica $X=W_{GD}$

→	$M_x(x)$	$M_o(x)$	θ	$M_x M_o$	$M_x \theta$	$M_x M_x$	$\int M_x(M_o/EJ+\theta)dx$	$\int X M_x M_x/EJdx$	
AB b	0	-2Fx	0	0	0	0	0+0	0	
BA b	0	2Fb-2Fx	0	0	0	0			
BC $\sqrt{2}b$	0	-2Fb+ $\sqrt{2}Fx$	0	0	0	0	0	0	
BD b	0	0	0	0	0	0	0+0	0	
DB b	0	0	0	0	0	0			
DC b	0	-2Fx-1/2qx ²	0	0	0	0	0+0	0	
CD b	0	5/2Fb-3Fx+1/2qx ²	0	0	0	0			
CE b	0	-3/2Fb+2Fx-1/2qx ²	0	0	0	0	0+0	0	
EC b	0	Fx+1/2qx ²	0	0	0	0			
FG b	-1/2x/b	Fb-Fx	-Fb/EJ	-1/2Fx+1/2Fx ² /b	1/2Fx/EJ	1/4x ² /b ²	(-1/12+1/4)Fb ² /EJ	1/12Xb/EJ	
GF b	1/2-1/2x/b	-Fx	Fb/EJ	-1/2Fx+1/2Fx ² /b	1/2Fb/EJ-1/2Fx/EJ	1/4-1/2x/b+1/4x ² /b ²			
GD b	-1+x/b	-Fx	0	Fx-Fx ² /b	0	1-2x/b+x ² /b ²	(1/6+0)Fb ² /EJ	1/3Xb/EJ	
DG b	x/b	Fb-Fx	0	Fx-Fx ² /b	0	x ² /b ²			
DH b	0	-Fb+Fx	0	0	0	0	0+0	0	
HD b	0	Fx	0	0	0	0			
GA b	1/2-1/2x/b	0	0	0	0	1/4-1/2x/b+1/4x ² /b ²	0+0	1/12Xb/EJ	
AG b	-1/2x/b	0	0	0	0	1/4x ² /b ²			
	totali							1/3Fb ² /EJ	1/2Xb/EJ
	iperstatica $X=W_{GD}$							-2/3Fb	

Sviluppi di calcolo iperstatica

$$L_{FG}^{xx} = \int_0^b (1/4 x^2/b^2) 1/EJ dx = [1/12 x^3/b^2]_0^b 1/EJ$$

$$= (1/12 b) 1/EJ = 1/12 b/EJ$$

$$L_{GF}^{xx} = \int_0^b (1/4 - 1/2 x/b + 1/4 x^2/b^2) 1/EJ dx = [1/4 x - 1/4 x^2/b + 1/12 x^3/b^2]_0^b 1/EJ$$

$$= (1/4 b - 1/4 b + 1/12 b) 1/EJ = 1/12 b/EJ$$

$$L_{GD}^{xx} = \int_0^b (1 - 2 x/b + x^2/b^2) 1/EJ dx = [x - x^2/b + 1/3 x^3/b^2]_0^b 1/EJ$$

$$= (b - b + 1/3 b) 1/EJ = 1/3 b/EJ$$

$$L_{DG}^{xx} = \int_0^b (x^2/b^2) 1/EJ dx = [1/3 x^3/b^2]_0^b 1/EJ$$

$$= (1/3 b) 1/EJ = 1/3 b/EJ$$

$$L_{GA}^{xx} = \int_0^b (1/4 - 1/2 x/b + 1/4 x^2/b^2) 1/EJ dx = [1/4 x - 1/4 x^2/b + 1/12 x^3/b^2]_0^b 1/EJ$$

$$= (1/4 b - 1/4 b + 1/12 b) 1/EJ = 1/12 b/EJ$$

$$L_{AG}^{xx} = \int_0^b (1/4 x^2/b^2) 1/EJ dx = [1/12 x^3/b^2]_0^b 1/EJ$$

$$= (1/12 b) 1/EJ = 1/12 b/EJ$$

$$L_{FG}^{xo} = \int_0^b (-1/2 x/b + 1/2 x^2/b^2) Fb 1/EJ dx + \int_0^b (1/2 x/b) \theta dx$$

$$= [-1/4 x^2/b + 1/6 x^3/b^2]_0^b Fb 1/EJ + [1/4 x^2/b]_0^b \theta$$

$$= (-1/4 b + 1/6 b) Fb 1/EJ + (1/4 b) \theta = 1/6 Fb^2/EJ$$

$$L_{GF}^{xo} = \int_0^b (-1/2 x/b + 1/2 x^2/b^2) Fb 1/EJ dx + \int_0^b (-1/2 + 1/2 x/b) \theta dx$$

$$= [-1/4 x^2/b + 1/6 x^3/b^2]_0^b Fb 1/EJ + [-1/2 x + 1/4 x^2/b]_0^b \theta$$

$$= (-1/4 b + 1/6 b) Fb 1/EJ + (-1/2 b + 1/4 b) \theta = 1/6 Fb^2/EJ$$

$$L_{GD}^{xo} = \int_0^b (x/b - x^2/b^2) Fb 1/EJ dx = [1/2 x^2/b - 1/3 x^3/b^2]_0^b Fb 1/EJ$$

$$= (1/2 b - 1/3 b) Fb 1/EJ = 1/6 Fb^2/EJ$$

$$L_{DG}^{xo} = \int_0^b (x/b - x^2/b^2) Fb 1/EJ dx = [1/2 x^2/b - 1/3 x^3/b^2]_0^b Fb 1/EJ$$

$$= (1/2 b - 1/3 b) Fb 1/EJ = 1/6 Fb^2/EJ$$

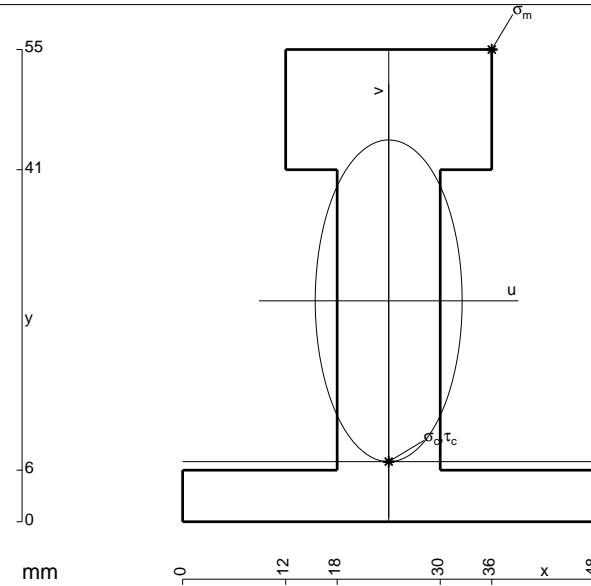

- A = 1044. mm²
- J_u = 366752. mm⁴
- J_v = 76464. mm⁴
- y_g = 25.73 mm
- T_y = -5010. N
- M_x = -3006000. Nmm
- x_m = 36. mm
- y_m = 55. mm
- u_m = 12. mm
- v_m = 29.27 mm
- σ_m = -Mv/J_u = 239.9 N/mm²
- x_c = 24. mm
- y_c = 7. mm
- v_c = -18.73 mm
- σ_c = -Mv/J_u = -153.5 N/mm²
- τ_c = 7.715 N/mm²
- σ_q = √σ²+3τ² = 154.1 N/mm²
- S = 6777. mm³

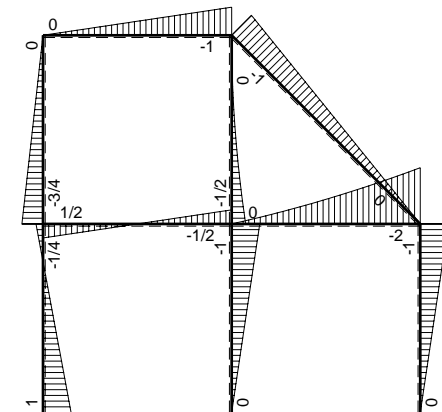
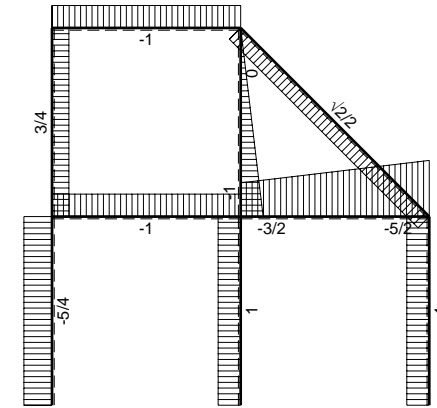
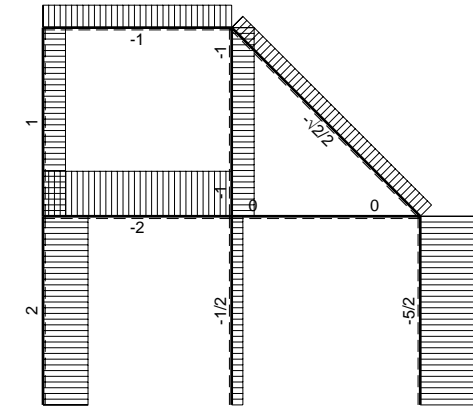
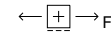
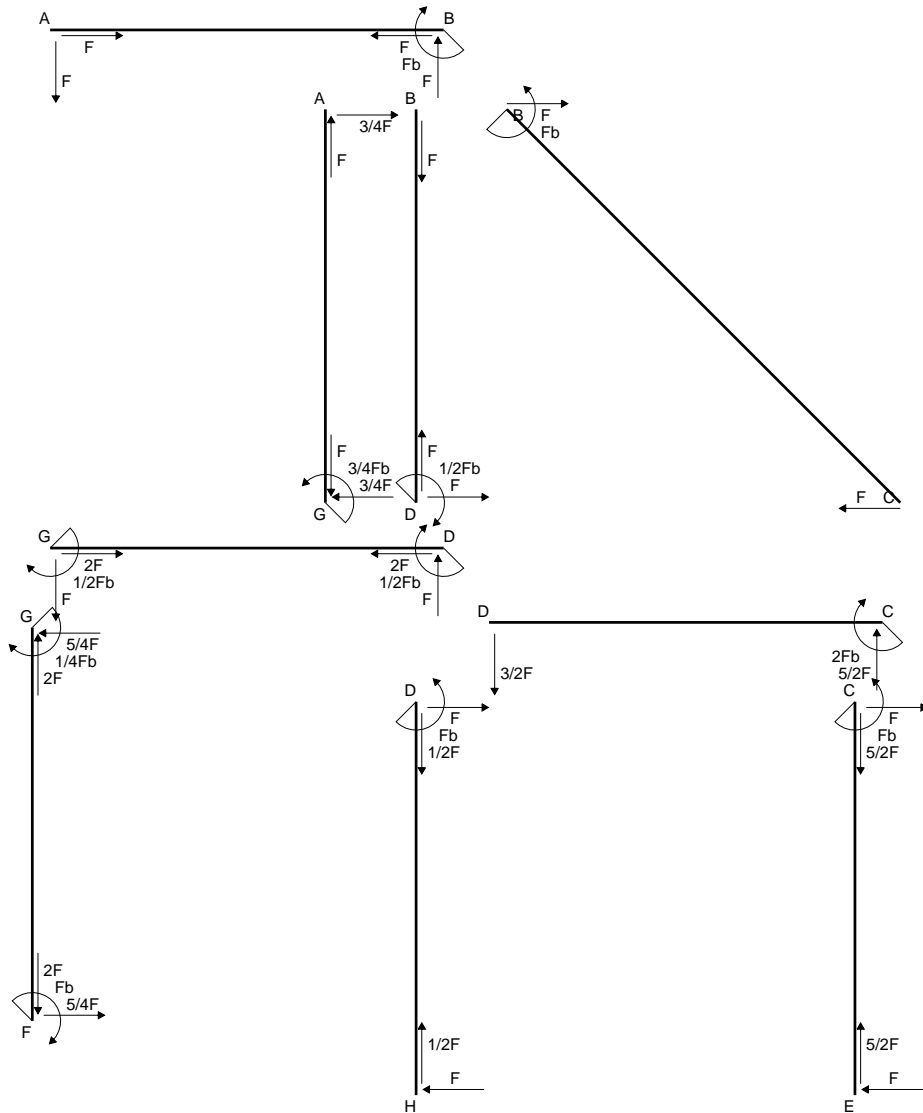

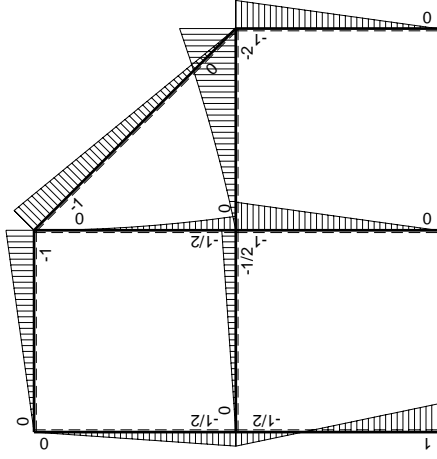
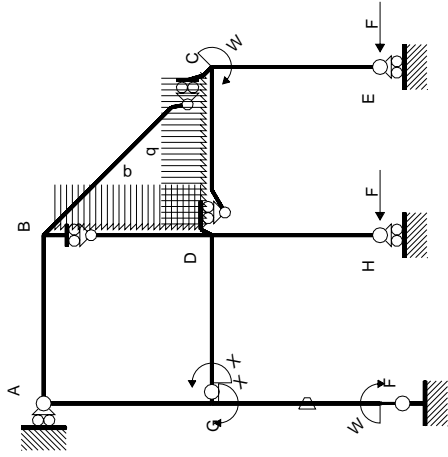

Schema di calcolo iperstatico

M_0 flessione da carichi assegnati

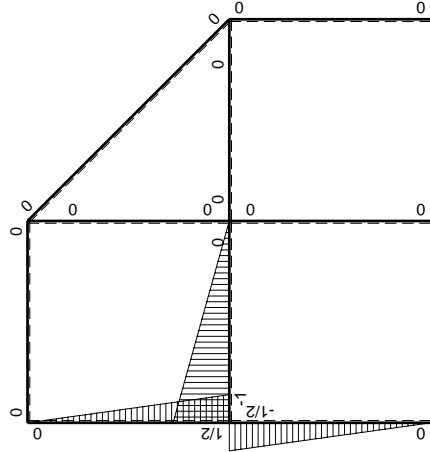

M_x flessione da iperstatica $X=1$

Quadro contributi PLV per iperstatica $X=W_{GD}$

→	$M_x(x)$	$M_o(x)$	θ	$M_x M_o$	$M_x \theta$	$M_x M_x$	$\int M_x(M_o/EJ+\theta)dx$	$\int X M_x M_x/EJ dx$
AB b	0	-Fx	0	0	0	0	0+0	0
BA b	0	Fb-Fx	0	0	0	0	0	0
BC $\sqrt{2}b$	0	-Fb+ $\sqrt{2}/2Fx$	0	0	0	0	0	0
BD b	0	-1/2qx ²	0	0	0	0	0+0	0
DB b	0	1/2Fb-Fx+1/2qx ²	0	0	0	0	0+0	0
DC b	0	-3/2Fx-1/2qx ²	0	0	0	0	0+0	0
CD b	0	2Fb-5/2Fx+1/2qx ²	0	0	0	0	0+0	0
CE b	0	-Fb+Fx	0	0	0	0	0+0	0
EC b	0	Fx	0	0	0	0	0+0	0
FG b	-1/2x/b	Fb-3/2Fx	-Fb/EJ	-1/2Fx+3/4Fx ² /b	1/2Fx/EJ	1/4x ² /b ²	(0+1/4)Fb ² /EJ	1/12Xb/EJ
GF b	1/2-1/2x/b	1/2Fb-3/2Fx	Fb/EJ	1/4Fb-Fx+3/4Fx ² /b	1/2Fb/EJ-1/2Fx/EJ	1/4-1/2x/b+1/4x ² /b ²		
GD b	-1+x/b	-1/2Fx	0	1/2Fx-1/2Fx ² /b	0	1-2x/b+x ² /b ²	(1/12+0)Fb ² /EJ	1/3Xb/EJ
DG b	x/b	1/2Fb-1/2Fx	0	1/2Fx-1/2Fx ² /b	0	x ² /b ²		
DH b	0	-Fb+Fx	0	0	0	0	0+0	0
HD b	0	Fx	0	0	0	0	0+0	0
GA b	1/2-1/2x/b	-1/2Fb+1/2Fx	0	-1/4Fb+1/2Fx-1/4Fx ² /b	0	1/4-1/2x/b+1/4x ² /b ²	(-1/12+0)Fb ² /EJ	1/12Xb/EJ
AG b	-1/2x/b	1/2Fx	0	-1/4Fx ² /b	0	1/4x ² /b ²		
	totali						1/4Fb ² /EJ	1/2Xb/EJ
	iperstatica $X=W_{GD}$						-1/2Fb	

Sviluppi di calcolo iperstatica

$$L_{FG}^{xx} = \int_0^b (1/4 x^2/b^2) 1/EJ dx = [1/12 x^3/b^2]_0^b 1/EJ$$

$$= (1/12 b) 1/EJ = 1/12 b/EJ$$

$$L_{GF}^{xx} = \int_0^b (1/4 - 1/2 x/b + 1/4 x^2/b^2) 1/EJ dx = [1/4 x - 1/4 x^2/b + 1/12 x^3/b^2]_0^b 1/EJ$$

$$= (1/4 b - 1/4 b + 1/12 b) 1/EJ = 1/12 b/EJ$$

$$L_{GD}^{xx} = \int_0^b (1 - 2 x/b + x^2/b^2) 1/EJ dx = [x - x^2/b + 1/3 x^3/b^2]_0^b 1/EJ$$

$$= (b - b + 1/3 b) 1/EJ = 1/3 b/EJ$$

$$L_{DG}^{xx} = \int_0^b (x^2/b^2) 1/EJ dx = [1/3 x^3/b^2]_0^b 1/EJ$$

$$= (1/3 b) 1/EJ = 1/3 b/EJ$$

$$L_{GA}^{xx} = \int_0^b (1/4 - 1/2 x/b + 1/4 x^2/b^2) 1/EJ dx = [1/4 x - 1/4 x^2/b + 1/12 x^3/b^2]_0^b 1/EJ$$

$$= (1/4 b - 1/4 b + 1/12 b) 1/EJ = 1/12 b/EJ$$

$$L_{AG}^{xx} = \int_0^b (1/4 x^2/b^2) 1/EJ dx = [1/12 x^3/b^2]_0^b 1/EJ$$

$$= (1/12 b) 1/EJ = 1/12 b/EJ$$

$$L_{FG}^{xo} = \int_0^b (-1/2 x/b + 3/4 x^2/b^2) Fb 1/EJ dx + \int_0^b (1/2 x/b) \theta dx$$

$$= [-1/4 x^2/b + 1/4 x^3/b^2]_0^b Fb 1/EJ + [1/4 x^2/b]_0^b \theta$$

$$= (-1/4 b + 1/4 b) Fb 1/EJ + (1/4 b) \theta = 1/4 Fb^2/EJ$$

$$L_{GF}^{xo} = \int_0^b (1/4 - x/b + 3/4 x^2/b^2) Fb 1/EJ dx + \int_0^b (-1/2 + 1/2 x/b) \theta dx$$

$$= [1/4 x - 1/2 x^2/b + 1/4 x^3/b^2]_0^b Fb 1/EJ + [-1/2 x + 1/4 x^2/b]_0^b \theta$$

$$= (1/4 b - 1/2 b + 1/4 b) Fb 1/EJ + (-1/2 b + 1/4 b) \theta = 1/4 Fb^2/EJ$$

$$L_{GD}^{xo} = \int_0^b (1/2 x/b - 1/2 x^2/b^2) Fb 1/EJ dx = [1/4 x^2/b - 1/6 x^3/b^2]_0^b Fb 1/EJ$$

$$= (1/4 b - 1/6 b) Fb 1/EJ = 1/12 Fb^2/EJ$$

$$L_{DG}^{xo} = \int_0^b (1/2 x/b - 1/2 x^2/b^2) Fb 1/EJ dx = [1/4 x^2/b - 1/6 x^3/b^2]_0^b Fb 1/EJ$$

$$= (1/4 b - 1/6 b) Fb 1/EJ = 1/12 Fb^2/EJ$$

$$L_{GA}^{xo} = \int_0^b (-1/4 + 1/2 x/b - 1/4 x^2/b^2) Fb 1/EJ dx = [-1/4 x + 1/4 x^2/b - 1/12 x^3/b^2]_0^b Fb 1/EJ$$

$$= (-1/4 b + 1/4 b - 1/12 b) Fb 1/EJ = -1/12 Fb^2/EJ$$

$$L_{AG}^{xo} = \int_0^b (-1/4 x^2/b^2) Fb 1/EJ dx = [-1/12 x^3/b^2]_0^b Fb 1/EJ$$

$$= (-1/12 b) Fb 1/EJ = -1/12 Fb^2/EJ$$

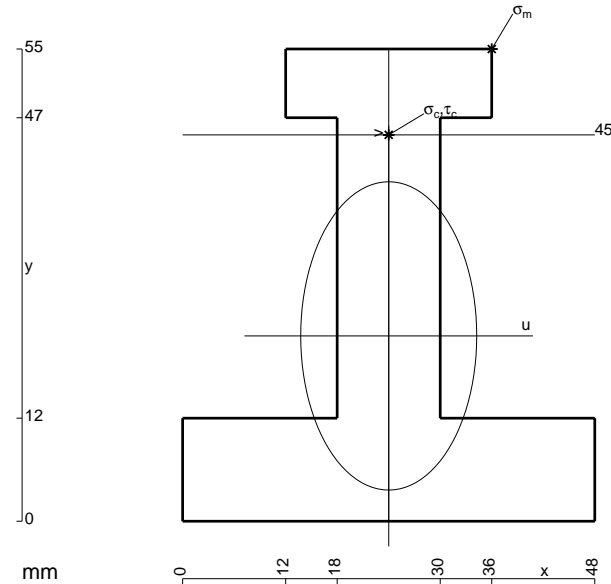

- A = 1188. mm²
- J_u = 383155. mm⁴
- J_v = 124848. mm⁴
- y_g = 21.58 mm
- T_y = -3650. N
- M_x = -2277600. Nmm
- x_m = 36. mm
- y_m = 55. mm
- u_m = 12. mm
- v_m = 33.42 mm
- σ_m = -Mv/J_u = 198.7 N/mm²
- x_c = 24. mm
- y_c = 45. mm
- v_c = 23.42 mm
- σ_c = -Mv/J_u = 139.2 N/mm²
- τ_c = 4.949 N/mm²
- σ_o = √σ²+3τ² = 139.5 N/mm²
- S = 6235. mm³

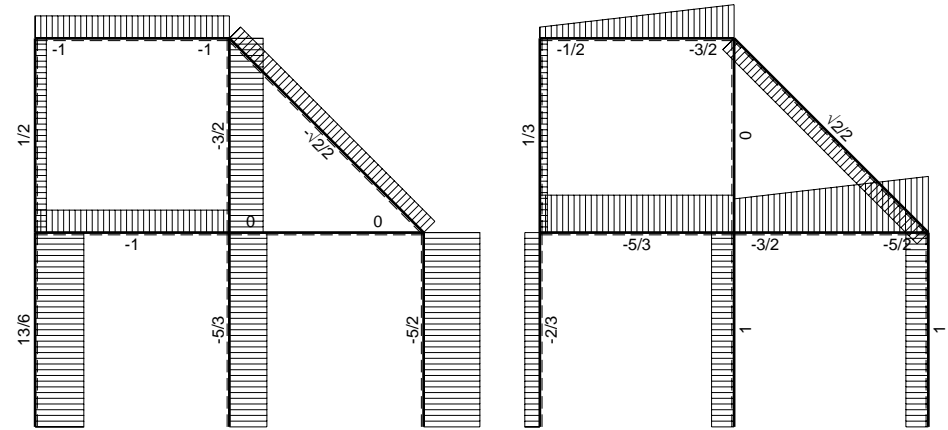
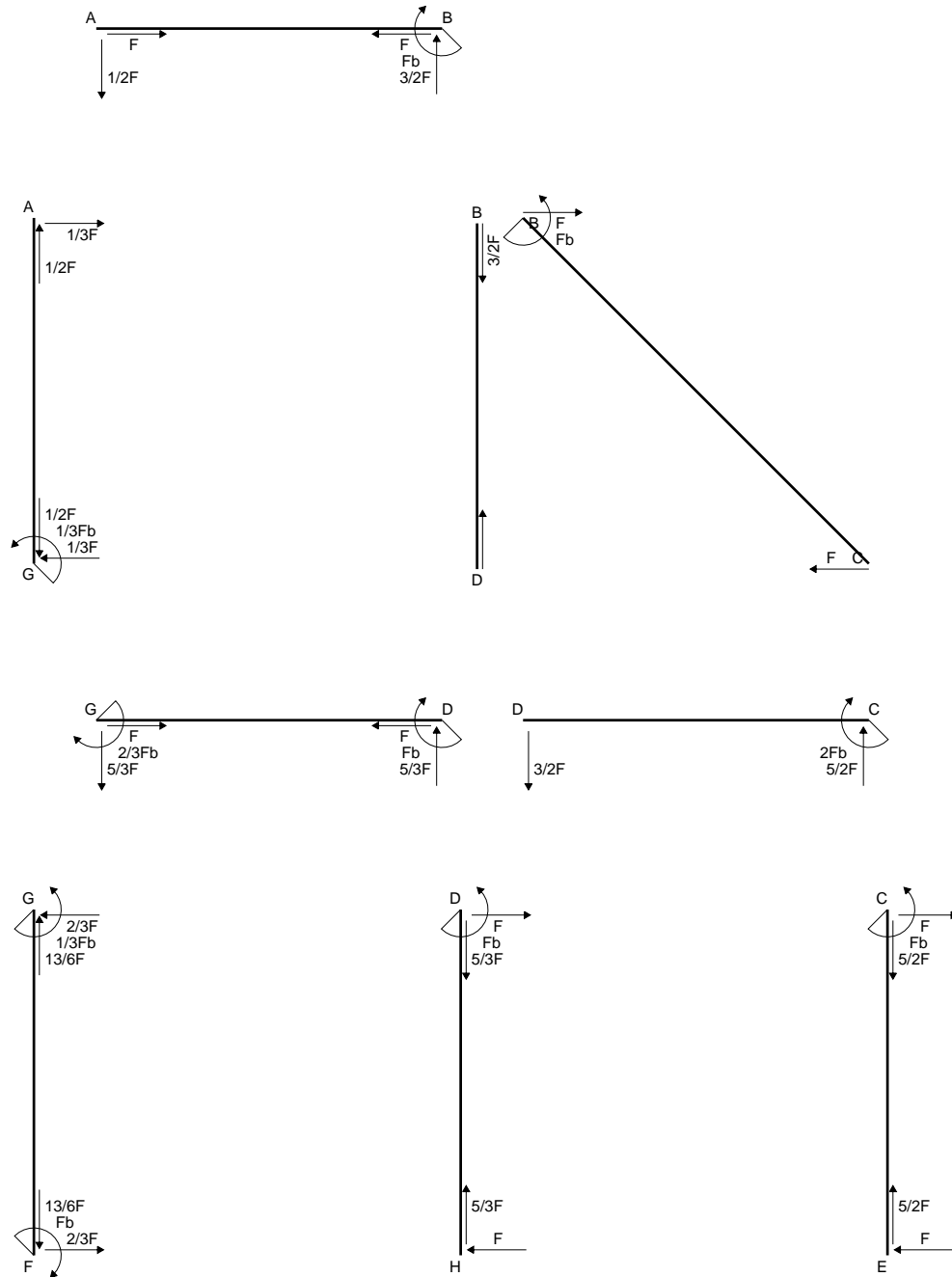

← ⊕ → F

↑ ⊕ ↓ F

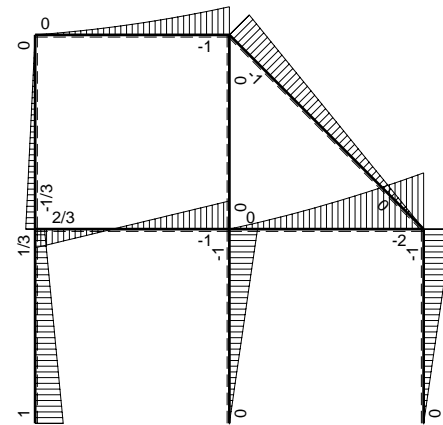

⊕ ⊖ F_b

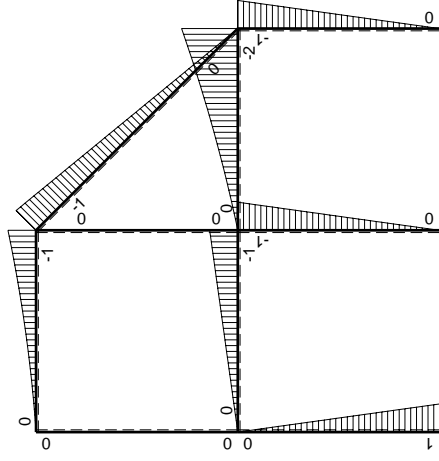
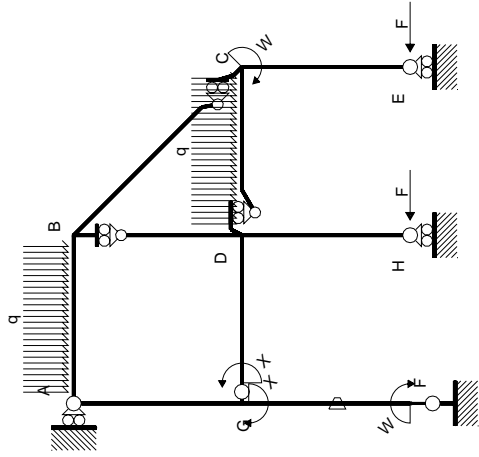

Schema di calcolo iperstatico

M_0 flessione da carichi assegnati

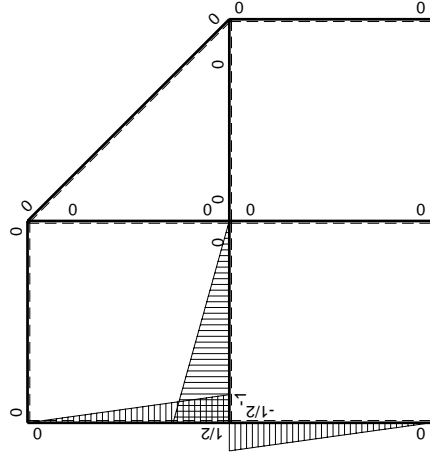

M_x flessione da iperstatica $X=1$

Quadro contributi PLV per iperstatica $X=W_{GD}$

→	$M_x(x)$	$M_o(x)$	θ	$M_x M_o$	$M_x \theta$	$M_x M_x$	$\int M_x(M_o/EJ+\theta)dx$	$\int X M_x M_x/EJ dx$	
AB b	0	$-1/2Fx-1/2qx^2$	0	0	0	0	0+0	0	
BA b	0	$Fb-3/2Fx+1/2qx^2$	0	0	0	0			
BC $\sqrt{2}b$	0	$-Fb+\sqrt{2}/2Fx$	0	0	0	0	0	0	
BD b	0	0	0	0	0	0	0+0	0	
DB b	0	0	0	0	0	0			
DC b	0	$-3/2Fx-1/2qx^2$	0	0	0	0	0+0	0	
CD b	0	$2Fb-5/2Fx+1/2qx^2$	0	0	0	0			
CE b	0	$-Fb+Fx$	0	0	0	0	0+0	0	
EC b	0	Fx	0	0	0	0			
FG b	$-1/2x/b$	$Fb-Fx$	$-Fb/EJ$	$-1/2Fx+1/2Fx^2/b$	$1/2Fx/EJ$	$1/4x^2/b^2$	$(-1/12+1/4)Fb^2/EJ$	$1/12Xb/EJ$	
GF b	$1/2-1/2x/b$	$-Fx$	Fb/EJ	$-1/2Fx+1/2Fx^2/b$	$1/2Fb/EJ-1/2Fx/EJ$	$1/4-1/2x/b+1/4x^2/b^2$			
GD b	$-1+x/b$	$-Fx$	0	$Fx-Fx^2/b$	0	$1-2x/b+x^2/b^2$	$(1/6+0)Fb^2/EJ$	$1/3Xb/EJ$	
DG b	x/b	$Fb-Fx$	0	$Fx-Fx^2/b$	0	x^2/b^2			
DH b	0	$-Fb+Fx$	0	0	0	0	0+0	0	
HD b	0	Fx	0	0	0	0			
GA b	$1/2-1/2x/b$	0	0	0	0	$1/4-1/2x/b+1/4x^2/b^2$	0+0	$1/12Xb/EJ$	
AG b	$-1/2x/b$	0	0	0	0	$1/4x^2/b^2$			
	totali							$1/3Fb^2/EJ$	$1/2Xb/EJ$
	iperstatica $X=W_{GD}$							$-2/3Fb$	

Sviluppi di calcolo iperstatica

$$L_{FG}^{xx} = \int_0^b (1/4 x^2/b^2) 1/EJ dx = [1/12 x^3/b^2]_0^b 1/EJ$$

$$= (1/12 b) 1/EJ = 1/12 b/EJ$$

$$L_{GF}^{xx} = \int_0^b (1/4 - 1/2 x/b + 1/4 x^2/b^2) 1/EJ dx = [1/4 x - 1/4 x^2/b + 1/12 x^3/b^2]_0^b 1/EJ$$

$$= (1/4 b - 1/4 b + 1/12 b) 1/EJ = 1/12 b/EJ$$

$$L_{GD}^{xx} = \int_0^b (1 - 2 x/b + x^2/b^2) 1/EJ dx = [x - x^2/b + 1/3 x^3/b^2]_0^b 1/EJ$$

$$= (b - b + 1/3 b) 1/EJ = 1/3 b/EJ$$

$$L_{DG}^{xx} = \int_0^b (x^2/b^2) 1/EJ dx = [1/3 x^3/b^2]_0^b 1/EJ$$

$$= (1/3 b) 1/EJ = 1/3 b/EJ$$

$$L_{GA}^{xx} = \int_0^b (1/4 - 1/2 x/b + 1/4 x^2/b^2) 1/EJ dx = [1/4 x - 1/4 x^2/b + 1/12 x^3/b^2]_0^b 1/EJ$$

$$= (1/4 b - 1/4 b + 1/12 b) 1/EJ = 1/12 b/EJ$$

$$L_{AG}^{xx} = \int_0^b (1/4 x^2/b^2) 1/EJ dx = [1/12 x^3/b^2]_0^b 1/EJ$$

$$= (1/12 b) 1/EJ = 1/12 b/EJ$$

$$L_{FG}^{xo} = \int_0^b (-1/2 x/b + 1/2 x^2/b^2) Fb 1/EJ dx + \int_0^b (1/2 x/b) \theta dx$$

$$= [-1/4 x^2/b + 1/6 x^3/b^2]_0^b Fb 1/EJ + [1/4 x^2/b]_0^b \theta$$

$$= (-1/4 b + 1/6 b) Fb 1/EJ + (1/4 b) \theta = 1/6 Fb^2/EJ$$

$$L_{GF}^{xo} = \int_0^b (-1/2 x/b + 1/2 x^2/b^2) Fb 1/EJ dx + \int_0^b (-1/2 + 1/2 x/b) \theta dx$$

$$= [-1/4 x^2/b + 1/6 x^3/b^2]_0^b Fb 1/EJ + [-1/2 x + 1/4 x^2/b]_0^b \theta$$

$$= (-1/4 b + 1/6 b) Fb 1/EJ + (-1/2 b + 1/4 b) \theta = 1/6 Fb^2/EJ$$

$$L_{GD}^{xo} = \int_0^b (x/b - x^2/b^2) Fb 1/EJ dx = [1/2 x^2/b - 1/3 x^3/b^2]_0^b Fb 1/EJ$$

$$= (1/2 b - 1/3 b) Fb 1/EJ = 1/6 Fb^2/EJ$$

$$L_{DG}^{xo} = \int_0^b (x/b - x^2/b^2) Fb 1/EJ dx = [1/2 x^2/b - 1/3 x^3/b^2]_0^b Fb 1/EJ$$

$$= (1/2 b - 1/3 b) Fb 1/EJ = 1/6 Fb^2/EJ$$

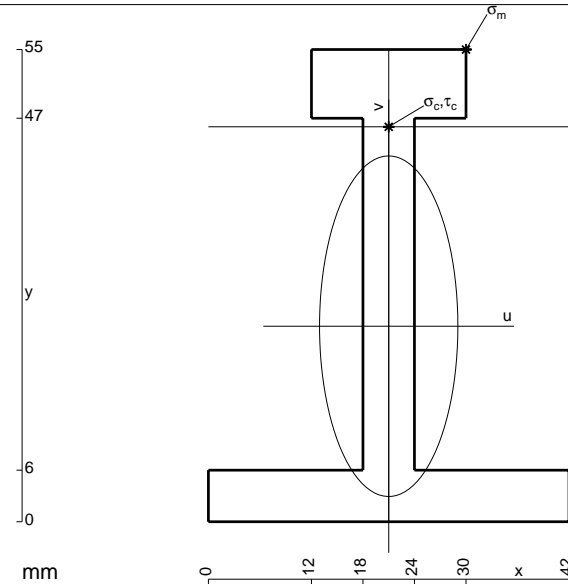

- A = 642. mm²
- J_u = 252660. mm⁴
- J_v = 41670. mm⁴
- y_g = 22.77 mm
- T_y = -2475. N
- M_x = -1643400. Nmm
- x_m = 30. mm
- y_m = 55. mm
- u_m = 9. mm
- v_m = 32.23 mm
- σ_m = -Mv/J_u = 209.6 N/mm²
- x_c = 21. mm
- y_c = 46. mm
- v_c = 23.23 mm
- σ_c = -Mv/J_u = 151.1 N/mm²
- τ_c = 6.869 N/mm²
- σ_q = √σ²+3τ² = 151.6 N/mm²
- S = 4207. mm³

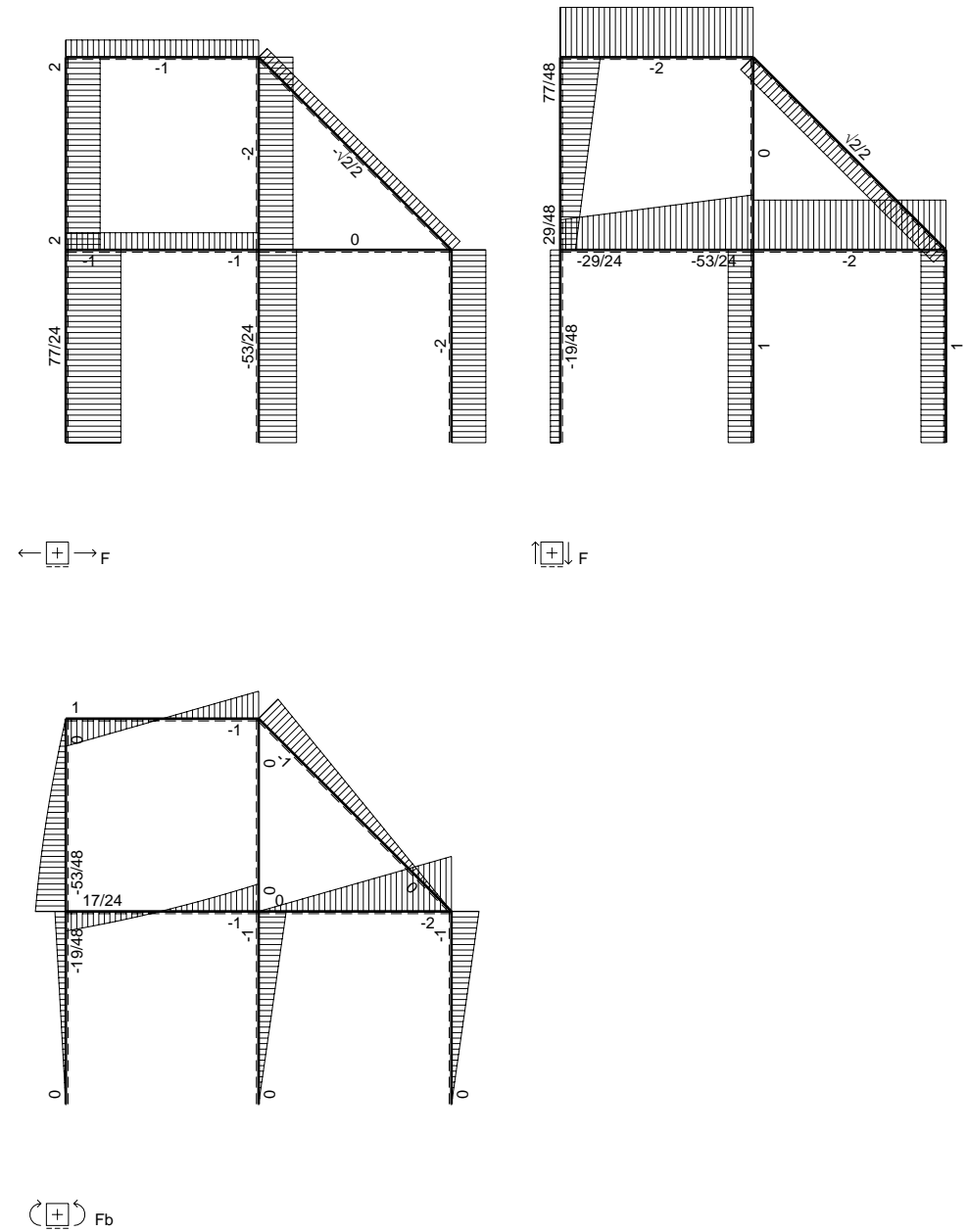
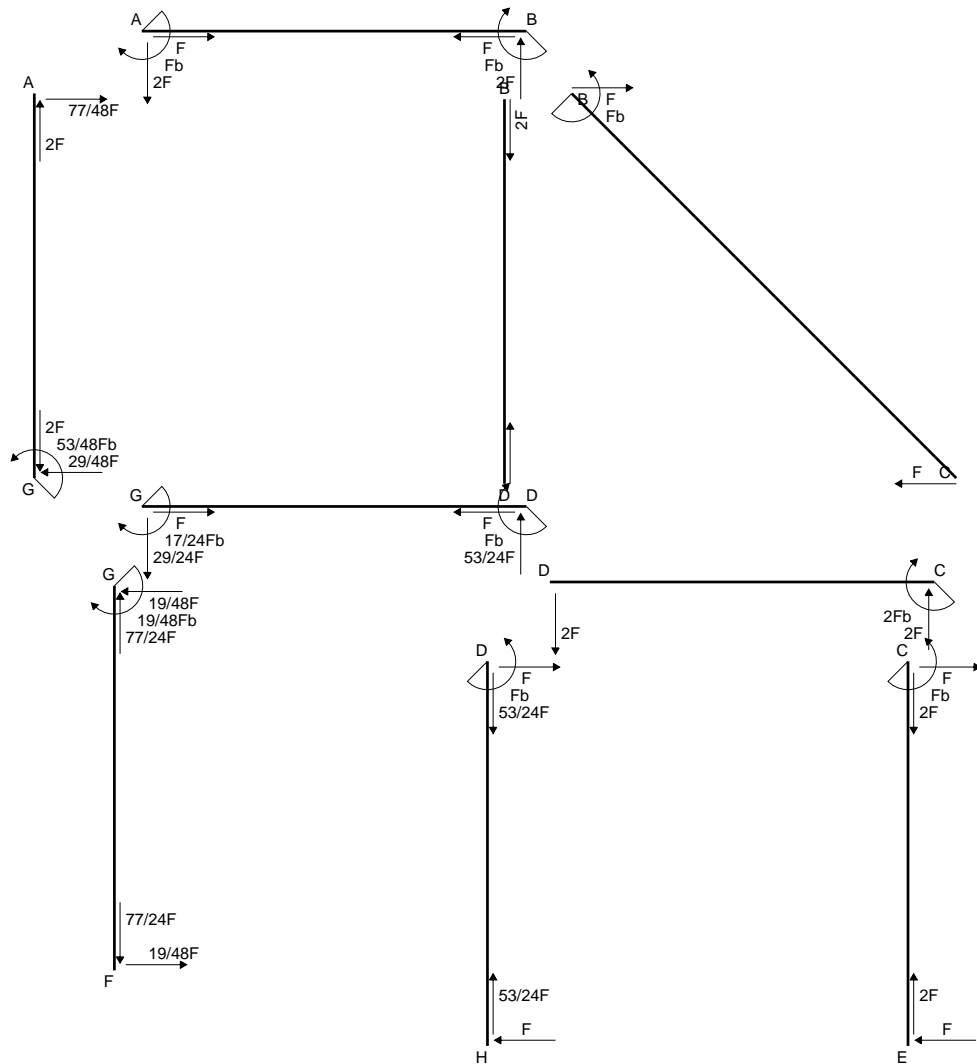

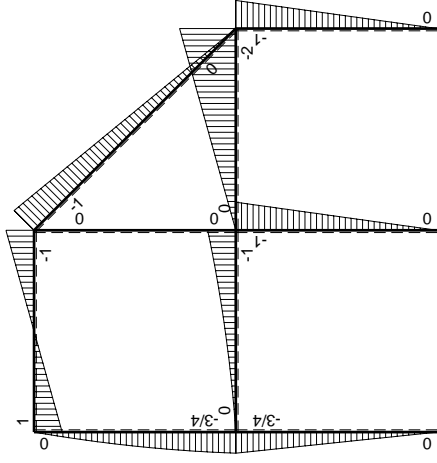
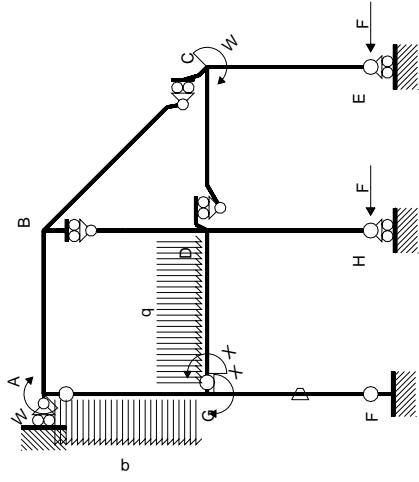

Schema di calcolo iperstatico

M_0 flessione da carichi assegnati

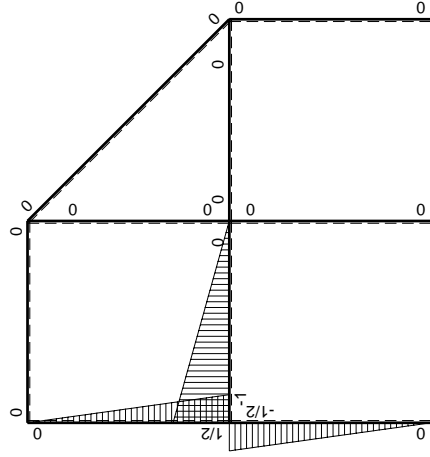

M_x flessione da iperstatica $X=1$

Quadro contributi PLV per iperstatica $X=W_{GD}$

→	$M_x(x)$	$M_o(x)$	θ	$M_x M_o$	$M_x \theta$	$M_x M_x$	$\int M_x(M_o/EJ+\theta)dx$	$\int X M_x M_x/EJ dx$
AB b	0	Fb-2Fx	0	0	0	0	0+0	0
BA b	0	Fb-2Fx	0	0	0	0	0	0
BC $\sqrt{2}b$	0	-Fb+ $\sqrt{2}/2Fx$	0	0	0	0	0	0
BD b	0	0	0	0	0	0	0+0	0
DB b	0	0	0	0	0	0	0	0
DC b	0	-2Fx	0	0	0	0	0+0	0
CD b	0	2Fb-2Fx	0	0	0	0	0	0
CE b	0	-Fb+Fx	0	0	0	0	0+0	0
EC b	0	Fx	0	0	0	0	0	0
FG b	-1/2x/b	-3/4Fx	-Fb/EJ	$3/8Fx^2/b$	$1/2Fx/EJ$	$1/4x^2/b^2$	$(1/8+1/4)Fb^2/EJ$	$1/12Xb/EJ$
GF b	$1/2-1/2x/b$	$3/4Fb-3/4Fx$	Fb/EJ	$3/8Fb-3/4Fx+3/8Fx^2/b$	$1/2Fb/EJ-1/2Fx/EJ$	$1/4-1/2x/b+1/4x^2/b^2$		
GD b	-1+x/b	-1/2Fx-1/2qx ²	0	$1/2Fx-1/2qx^3/b$	0	$1-2x/b+x^2/b^2$	$(1/8+0)Fb^2/EJ$	$1/3Xb/EJ$
DG b	x/b	Fb-3/2Fx+1/2qx ²	0	$Fx-3/2Fx^2/b+1/2qx^3/b$	0	x^2/b^2		
DH b	0	-Fb+Fx	0	0	0	0	0+0	0
HD b	0	Fx	0	0	0	0	0	0
GA b	$1/2-1/2x/b$	$-3/4Fb+1/4Fx+1/2qx^2$	0	$-3/8Fb+1/2Fx+1/8Fx^2/b-1/4qx^3/b$	0	$1/4-1/2x/b+1/4x^2/b^2$	$(-7/48+0)Fb^2/EJ$	$1/12Xb/EJ$
AG b	-1/2x/b	$5/4Fx-1/2qx^2$	0	$-5/8Fx^2/b+1/4qx^3/b$	0	$1/4x^2/b^2$		
	totali						$17/48Fb^2/EJ$	$1/2Xb/EJ$
	iperstatica $X=W_{GD}$						-17/24Fb	

Sviluppi di calcolo iperstatica

$$L_{FG}^{xx} = \int_0^b (1/4 x^2/b^2) 1/EJ dx = [1/12 x^3/b^2]_0^b 1/EJ$$

$$= (1/12 b) 1/EJ = 1/12 b/EJ$$

$$L_{GF}^{xx} = \int_0^b (1/4 - 1/2 x/b + 1/4 x^2/b^2) 1/EJ dx = [1/4 x - 1/4 x^2/b + 1/12 x^3/b^2]_0^b 1/EJ$$

$$= (1/4 b - 1/4 b + 1/12 b) 1/EJ = 1/12 b/EJ$$

$$L_{GD}^{xx} = \int_0^b (1 - 2 x/b + x^2/b^2) 1/EJ dx = [x - x^2/b + 1/3 x^3/b^2]_0^b 1/EJ$$

$$= (b - b + 1/3 b) 1/EJ = 1/3 b/EJ$$

$$L_{DG}^{xx} = \int_0^b (x^2/b^2) 1/EJ dx = [1/3 x^3/b^2]_0^b 1/EJ$$

$$= (1/3 b) 1/EJ = 1/3 b/EJ$$

$$L_{GA}^{xx} = \int_0^b (1/4 - 1/2 x/b + 1/4 x^2/b^2) 1/EJ dx = [1/4 x - 1/4 x^2/b + 1/12 x^3/b^2]_0^b 1/EJ$$

$$= (1/4 b - 1/4 b + 1/12 b) 1/EJ = 1/12 b/EJ$$

$$L_{AG}^{xx} = \int_0^b (1/4 x^2/b^2) 1/EJ dx = [1/12 x^3/b^2]_0^b 1/EJ$$

$$= (1/12 b) 1/EJ = 1/12 b/EJ$$

$$L_{FG}^{xo} = \int_0^b (3/8 x^2/b^2) Fb 1/EJ dx + \int_0^b (1/2 x/b) \theta dx = [1/8 x^3/b^2]_0^b Fb 1/EJ + [1/4 x^2/b]_0^b \theta$$

$$= (1/8 b) Fb 1/EJ + (1/4 b) \theta = 3/8 Fb^2/EJ$$

$$L_{GF}^{xo} = \int_0^b (3/8 - 3/4 x/b + 3/8 x^2/b^2) Fb 1/EJ dx + \int_0^b (-1/2 + 1/2 x/b) \theta dx$$

$$= [3/8 x - 3/8 x^2/b + 1/8 x^3/b^2]_0^b Fb 1/EJ + [-1/2 x + 1/4 x^2/b]_0^b \theta$$

$$= (3/8 b - 3/8 b + 1/8 b) Fb 1/EJ + (-1/2 b + 1/4 b) \theta = 3/8 Fb^2/EJ$$

$$L_{GD}^{xo} = \int_0^b (1/2 x/b - 1/2 x^3/b^3) Fb 1/EJ dx = [1/4 x^2/b - 1/8 x^4/b^3]_0^b Fb 1/EJ$$

$$= (1/4 b - 1/8 b) Fb 1/EJ = 1/8 Fb^2/EJ$$

$$L_{DG}^{xo} = \int_0^b (x/b - 3/2 x^2/b^2 + 1/2 x^3/b^3) Fb 1/EJ dx = [1/2 x^2/b - 1/2 x^3/b^2 + 1/8 x^4/b^3]_0^b Fb 1/EJ$$

$$= (1/2 b - 1/2 b + 1/8 b) Fb 1/EJ = 1/8 Fb^2/EJ$$

$$L_{GA}^{xo} = \int_0^b (-3/8 + 1/2 x/b + 1/8 x^2/b^2 - 1/4 x^3/b^3) Fb 1/EJ dx$$

$$= [-3/8 x + 1/4 x^2/b + 1/24 x^3/b^2 - 1/16 x^4/b^3]_0^b Fb 1/EJ$$

$$= (-3/8 b + 1/4 b + 1/24 b - 1/16 b) Fb 1/EJ = -7/48 Fb^2/EJ$$

$$L_{AG}^{xo} = \int_0^b (-5/8 x^2/b^2 + 1/4 x^3/b^3) Fb 1/EJ dx = [-5/24 x^3/b^2 + 1/16 x^4/b^3]_0^b Fb 1/EJ$$

$$= (-5/24 b + 1/16 b) Fb 1/EJ = -7/48 Fb^2/EJ$$

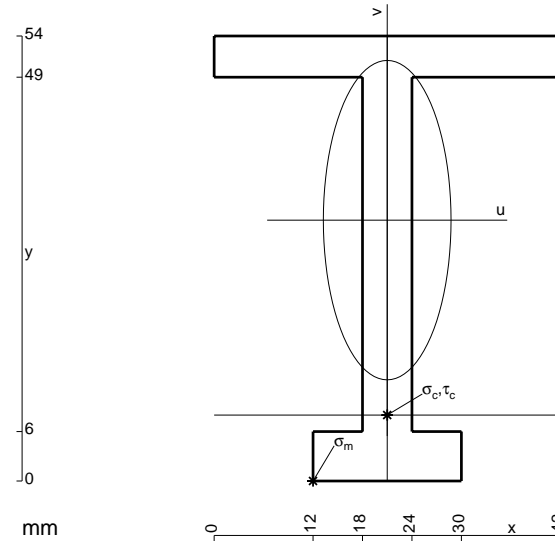

$A = 576. \text{ mm}^2$
 $J_u = 216352. \text{ mm}^4$
 $J_v = 34560. \text{ mm}^4$
 $y_g = 31.66 \text{ mm}$
 $T_y = -1740. \text{ N}$
 $M_x = -1496400. \text{ Nmm}$
 $x_m = 12. \text{ mm}$
 $u_m = -9. \text{ mm}$
 $v_m = -31.66 \text{ mm}$
 $\sigma_m = -Mv/J_u = -219. \text{ N/mm}^2$
 $x_c = 21. \text{ mm}$
 $y_c = 8. \text{ mm}$
 $v_c = -23.66 \text{ mm}$
 $\sigma_c = -Mv/J_u = -163.6 \text{ N/mm}^2$
 $\tau_c = 4.545 \text{ N/mm}^2$
 $\sigma_q = \sqrt{\sigma^2 + 3\tau^2} = 163.8 \text{ N/mm}^2$
 $S = 3391. \text{ mm}^3$

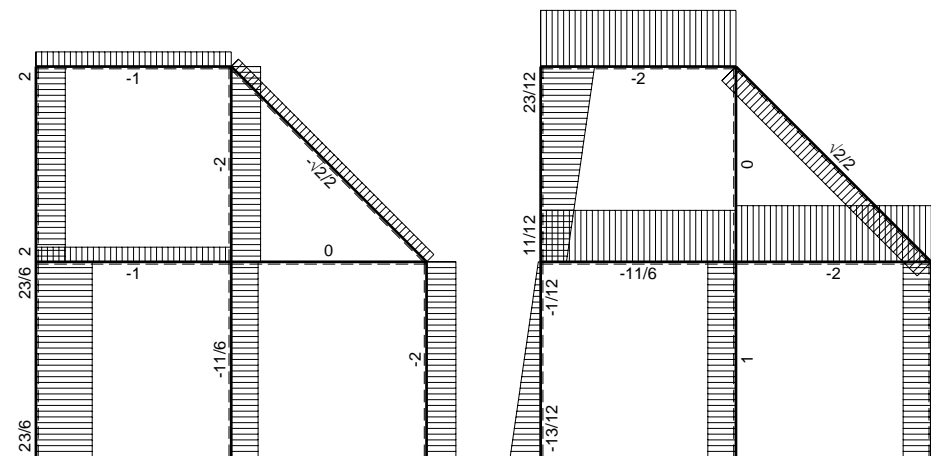
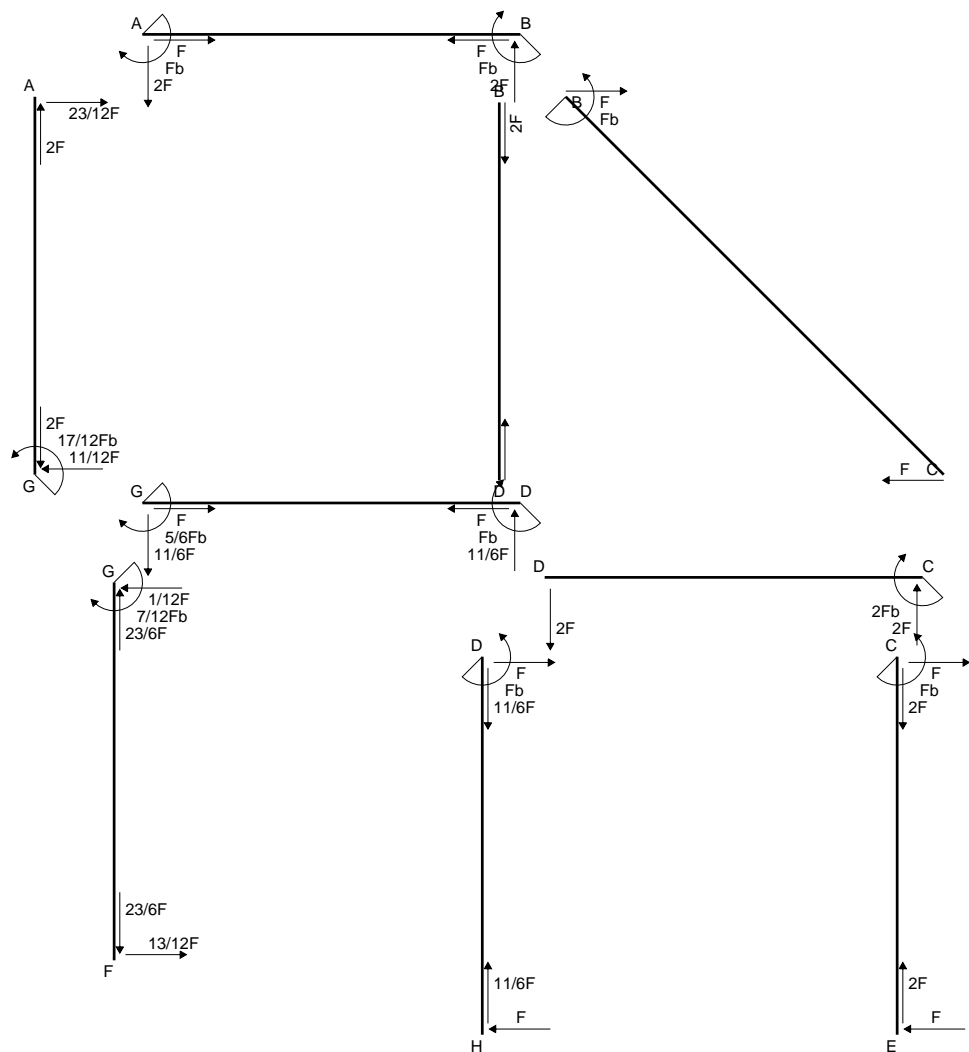

← ⊕ → F

↑ ⊕ ↓ F

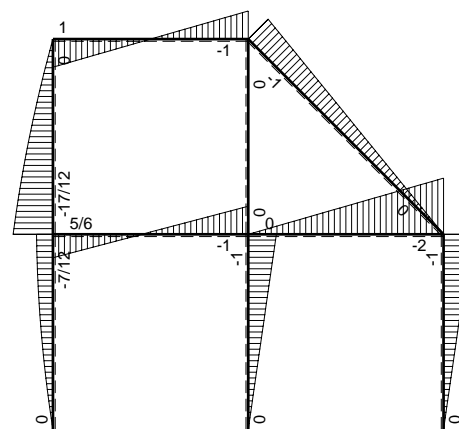

⊕ ⊖ F_b

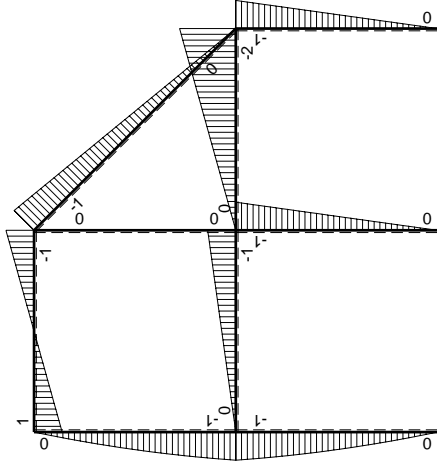
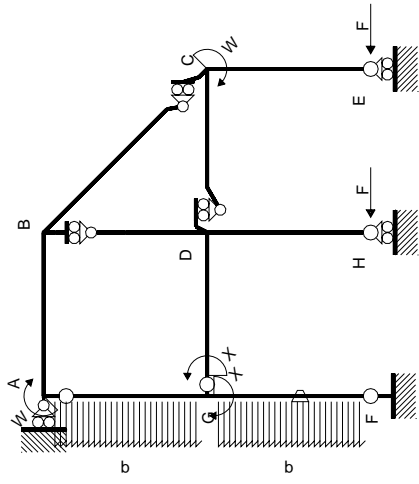

Schema di calcolo iperstatico

M_0 flessione da carichi assegnati

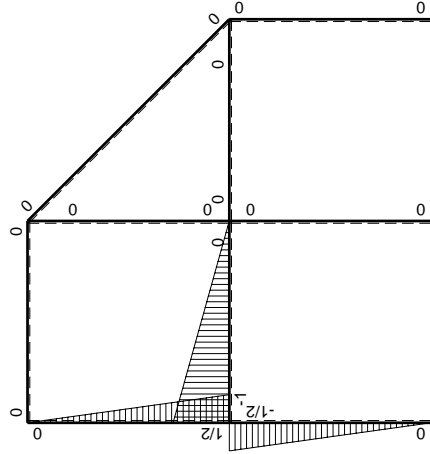

M_x flessione da iperstatica $X=1$

Quadro contributi PLV per iperstatica $X=W_{GD}$

→	$M_x(x)$	$M_o(x)$	θ	$M_x M_o$	$M_x \theta$	$M_x M_x$	$\int M_x(M_o/EJ+\theta)dx$	$\int X M_x M_x / EJ dx$
AB b	0	Fb-2Fx	0	0	0	0	0+0	0
BA b	0	Fb-2Fx	0	0	0	0		
BC $\sqrt{2}b$	0	-Fb+ $\sqrt{2}/2Fx$	0	0	0	0	0	0
BD b	0	0	0	0	0	0	0+0	0
DB b	0	0	0	0	0	0		
DC b	0	-2Fx	0	0	0	0	0+0	0
CD b	0	2Fb-2Fx	0	0	0	0		
CE b	0	-Fb+Fx	0	0	0	0	0+0	0
EC b	0	Fx	0	0	0	0		
FG b	-1/2x/b	-3/2Fx+1/2qx ²	-Fb/EJ	3/4Fx ² /b-1/4qx ³ /b	1/2Fx/EJ	1/4x ² /b ²	(3/16+1/4)Fb ² /EJ	1/12Xb/EJ
GF b	1/2-1/2x/b	Fb-1/2Fx-1/2qx ²	Fb/EJ	1/2Fb-3/4Fx+1/4qx ³ /b	1/2Fb/EJ-1/2Fx/EJ	1/4-1/2x/b+1/4x ² /b ²		
GD b	-1+x/b	-Fx	0	Fx-Fx ² /b	0	1-2x/b+x ² /b ²	(1/6+0)Fb ² /EJ	1/3Xb/EJ
DG b	x/b	Fb-Fx	0	Fx-Fx ² /b	0	x ² /b ²		
DH b	0	-Fb+Fx	0	0	0	0	0+0	0
HD b	0	Fx	0	0	0	0		
GA b	1/2-1/2x/b	-Fb+1/2Fx+1/2qx ²	0	-1/2Fb+3/4Fx-1/4qx ³ /b	0	1/4-1/2x/b+1/4x ² /b ²	(-3/16+0)Fb ² /EJ	1/12Xb/EJ
AG b	-1/2x/b	3/2Fx-1/2qx ²	0	-3/4Fx ² /b+1/4qx ³ /b	0	1/4x ² /b ²		
	totali						5/12Fb ² /EJ	1/2Xb/EJ
	iperstatica $X=W_{GD}$						-5/6Fb	

Sviluppi di calcolo iperstatica

$$L_{FG}^{xx} = \int_0^b (1/4 x^2/b^2) 1/EJ dx = [1/12 x^3/b^2]_0^b 1/EJ$$

$$= (1/12 b) 1/EJ = 1/12 b/EJ$$

$$L_{GF}^{xx} = \int_0^b (1/4 - 1/2 x/b + 1/4 x^2/b^2) 1/EJ dx = [1/4 x - 1/4 x^2/b + 1/12 x^3/b^2]_0^b 1/EJ$$

$$= (1/4 b - 1/4 b + 1/12 b) 1/EJ = 1/12 b/EJ$$

$$L_{GD}^{xx} = \int_0^b (1 - 2 x/b + x^2/b^2) 1/EJ dx = [x - x^2/b + 1/3 x^3/b^2]_0^b 1/EJ$$

$$= (b - b + 1/3 b) 1/EJ = 1/3 b/EJ$$

$$L_{DG}^{xx} = \int_0^b (x^2/b^2) 1/EJ dx = [1/3 x^3/b^2]_0^b 1/EJ$$

$$= (1/3 b) 1/EJ = 1/3 b/EJ$$

$$L_{GA}^{xx} = \int_0^b (1/4 - 1/2 x/b + 1/4 x^2/b^2) 1/EJ dx = [1/4 x - 1/4 x^2/b + 1/12 x^3/b^2]_0^b 1/EJ$$

$$= (1/4 b - 1/4 b + 1/12 b) 1/EJ = 1/12 b/EJ$$

$$L_{AG}^{xx} = \int_0^b (1/4 x^2/b^2) 1/EJ dx = [1/12 x^3/b^2]_0^b 1/EJ$$

$$= (1/12 b) 1/EJ = 1/12 b/EJ$$

$$L_{FG}^{xo} = \int_0^b (3/4 x^2/b^2 - 1/4 x^3/b^3) Fb 1/EJ dx + \int_0^b (1/2 x/b) \theta dx$$

$$= [1/4 x^3/b^2 - 1/16 x^4/b^3]_0^b Fb 1/EJ + [1/4 x^2/b]_0^b \theta$$

$$= (1/4 b - 1/16 b) Fb 1/EJ + (1/4 b) \theta = 7/16 Fb^2/EJ$$

$$L_{GF}^{xo} = \int_0^b (1/2 - 3/4 x/b + 1/4 x^2/b^2) Fb 1/EJ dx + \int_0^b (-1/2 + 1/2 x/b) \theta dx$$

$$= [1/2 x - 3/8 x^2/b + 1/16 x^3/b^2]_0^b Fb 1/EJ + [-1/2 x + 1/4 x^2/b]_0^b \theta$$

$$= (1/2 b - 3/8 b + 1/16 b) Fb 1/EJ + (-1/2 b + 1/4 b) \theta = 7/16 Fb^2/EJ$$

$$L_{GD}^{xo} = \int_0^b (x/b - x^2/b^2) Fb 1/EJ dx = [1/2 x^2/b - 1/3 x^3/b^2]_0^b Fb 1/EJ$$

$$= (1/2 b - 1/3 b) Fb 1/EJ = 1/6 Fb^2/EJ$$

$$L_{DG}^{xo} = \int_0^b (x/b - x^2/b^2) Fb 1/EJ dx = [1/2 x^2/b - 1/3 x^3/b^2]_0^b Fb 1/EJ$$

$$= (1/2 b - 1/3 b) Fb 1/EJ = 1/6 Fb^2/EJ$$

$$L_{GA}^{xo} = \int_0^b (-1/2 + 3/4 x/b - 1/4 x^2/b^2) Fb 1/EJ dx = [-1/2 x + 3/8 x^2/b - 1/16 x^3/b^2]_0^b Fb 1/EJ$$

$$= (-1/2 b + 3/8 b - 1/16 b) Fb 1/EJ = -3/16 Fb^2/EJ$$

$$L_{AG}^{xo} = \int_0^b (-3/4 x^2/b^2 + 1/4 x^3/b^3) Fb 1/EJ dx = [-1/4 x^3/b^2 + 1/16 x^4/b^3]_0^b Fb 1/EJ$$

$$= (-1/4 b + 1/16 b) Fb 1/EJ = -3/16 Fb^2/EJ$$

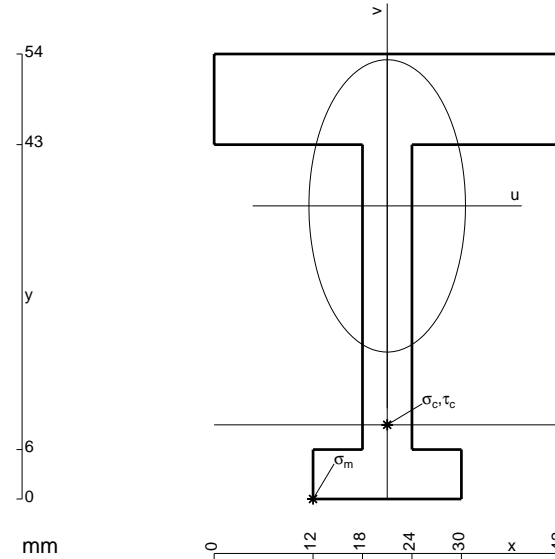

$$A = 792. \text{ mm}^2$$

$$J_u = 249320. \text{ mm}^4$$

$$J_v = 71496. \text{ mm}^4$$

$$y_g = 35.57 \text{ mm}$$

$$T_y = -1760. \text{ N}$$

$$M_x = -1601600. \text{ Nmm}$$

$$x_m = 12. \text{ mm}$$

$$u_m = -9. \text{ mm}$$

$$v_m = -35.57 \text{ mm}$$

$$\sigma_m = -Mv/J_u = -228.5 \text{ N/mm}^2$$

$$x_c = 21. \text{ mm}$$

$$y_c = 9. \text{ mm}$$

$$v_c = -26.57 \text{ mm}$$

$$\sigma_c = -Mv/J_u = -170.7 \text{ N/mm}^2$$

$$\tau_c = 4.733 \text{ N/mm}^2$$

$$\sigma_q = \sqrt{\sigma^2 + 3\tau^2} = 170.9 \text{ N/mm}^2$$

$$S = 4023. \text{ mm}^3$$

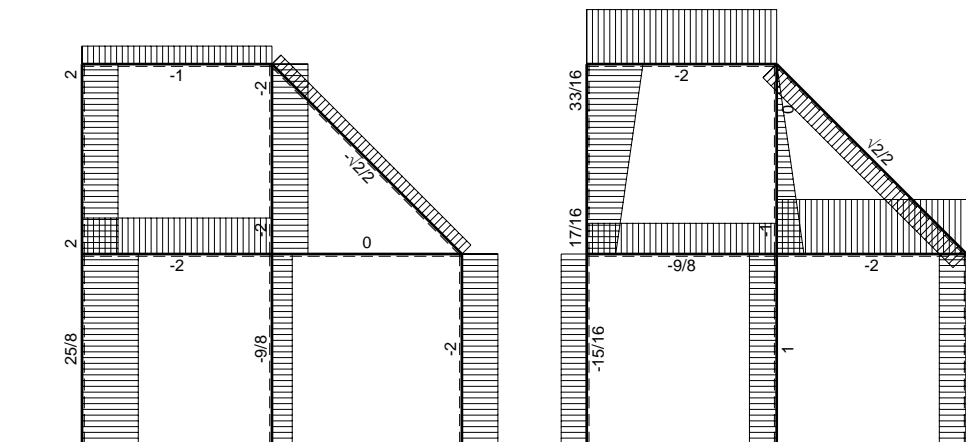
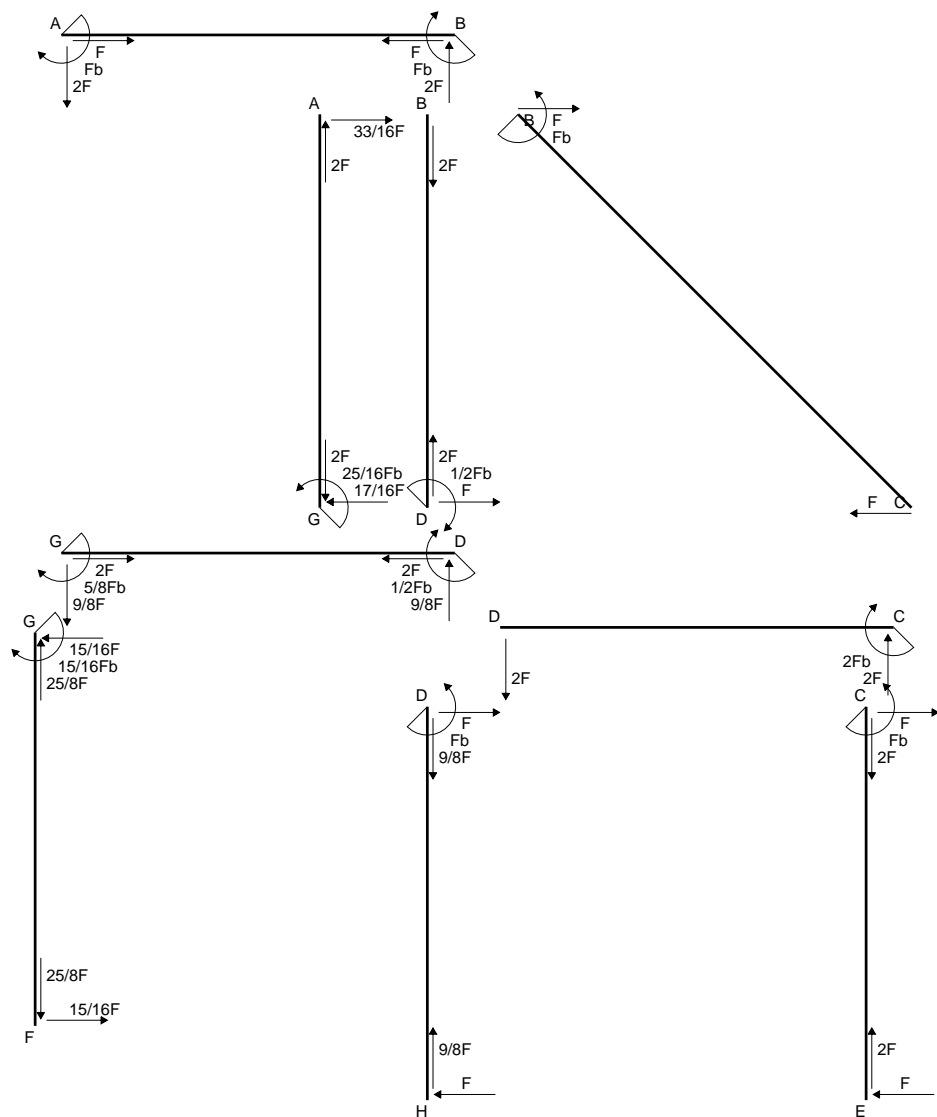

← ⊕ → F

↑ ⊕ ↓ F

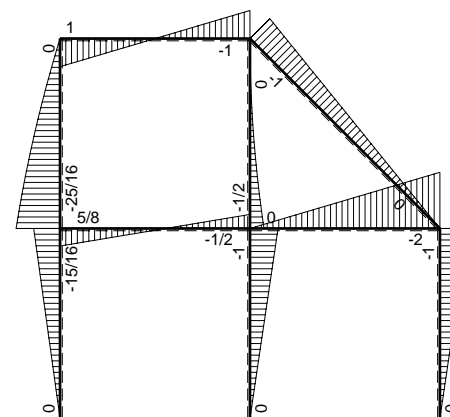

⊕ Fb

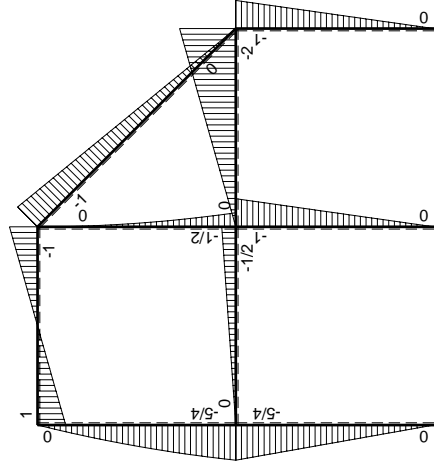
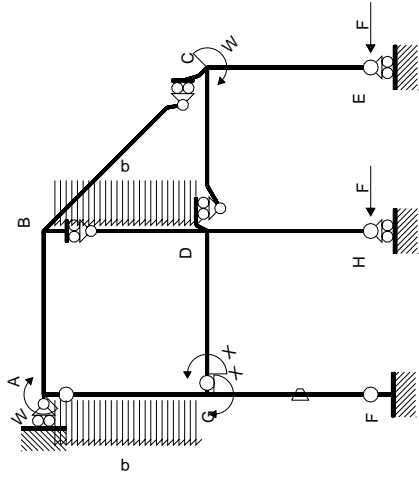

Schema di calcolo iperstatico

M_0 flessione da carichi assegnati

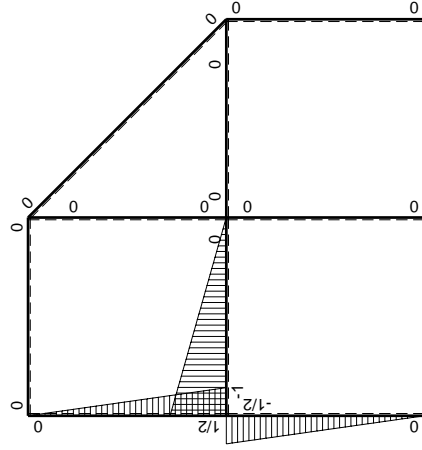

M_1 flessione da iperstatica $X=1$

Quadro contributi PLV per iperstatica $X=W_{GD}$

→	$M_x(x)$	$M_o(x)$	θ	$M_x M_o$	$M_x \theta$	$M_x M_x$	$\int M_x(M_o/EJ+\theta)dx$	$\int X M_x M_x/EJ dx$
AB b	0	Fb-2Fx	0	0	0	0	0+0	0
BA b	0	Fb-2Fx	0	0	0	0	0	0
BC $\sqrt{2}b$	0	-Fb+ $\sqrt{2}/2Fx$	0	0	0	0	0	0
BD b	0	-1/2qx ²	0	0	0	0	0+0	0
DB b	0	1/2Fb-Fx+1/2qx ²	0	0	0	0	0	0
DC b	0	-2Fx	0	0	0	0	0+0	0
CD b	0	2Fb-2Fx	0	0	0	0	0	0
CE b	0	-Fb+Fx	0	0	0	0	0+0	0
EC b	0	Fx	0	0	0	0	0	0
FG b	-1/2x/b	-5/4Fx	-Fb/EJ	5/8Fx ² /b	1/2Fx/EJ	1/4x ² /b ²	(5/24+1/4)Fb ² /EJ	1/12Xb/EJ
GF b	1/2-1/2x/b	5/4Fb-5/4Fx	Fb/EJ	5/8Fb-5/4Fx+5/8Fx ² /b	1/2Fb/EJ-1/2Fx/EJ	1/4-1/2x/b+1/4x ² /b ²		
GD b	-1+x/b	-1/2Fx	0	1/2Fx-1/2Fx ² /b	0	1-2x/b+x ² /b ²	(1/12+0)Fb ² /EJ	1/3Xb/EJ
DG b	x/b	1/2Fb-1/2Fx	0	1/2Fx-1/2Fx ² /b	0	x ² /b ²		
DH b	0	-Fb+Fx	0	0	0	0	0+0	0
HD b	0	Fx	0	0	0	0	0	0
GA b	1/2-1/2x/b	-5/4Fb+3/4Fx+1/2qx ²	0	-5/8Fb+Fx-1/8Fx ² /b-1/4qx ³ /b	0	1/4-1/2x/b+1/4x ² /b ²	(-11/48+0)Fb ² /EJ	1/12Xb/EJ
AG b	-1/2x/b	7/4Fx-1/2qx ²	0	-7/8Fx ² /b+1/4qx ³ /b	0	1/4x ² /b ²		
	totali						5/16Fb ² /EJ	1/2Xb/EJ
	iperstatica $X=W_{GD}$						-5/8Fb	

Sviluppi di calcolo iperstatica

$$L_{FG}^{xx} = \int_0^b (1/4 x^2/b^2) 1/EJ dx = [1/12 x^3/b^2]_0^b 1/EJ$$

$$= (1/12 b) 1/EJ = 1/12 b/EJ$$

$$L_{GF}^{xx} = \int_0^b (1/4 -1/2 x/b +1/4 x^2/b^2) 1/EJ dx = [1/4 x -1/4 x^2/b +1/12 x^3/b^2]_0^b 1/EJ$$

$$= (1/4 b -1/4 b +1/12 b) 1/EJ = 1/12 b/EJ$$

$$L_{GD}^{xx} = \int_0^b (1 -2 x/b + x^2/b^2) 1/EJ dx = [x - x^2/b +1/3 x^3/b^2]_0^b 1/EJ$$

$$= (b - b +1/3 b) 1/EJ = 1/3 b/EJ$$

$$L_{DG}^{xx} = \int_0^b (x^2/b^2) 1/EJ dx = [1/3 x^3/b^2]_0^b 1/EJ$$

$$= (1/3 b) 1/EJ = 1/3 b/EJ$$

$$L_{GA}^{xx} = \int_0^b (1/4 -1/2 x/b +1/4 x^2/b^2) 1/EJ dx = [1/4 x -1/4 x^2/b +1/12 x^3/b^2]_0^b 1/EJ$$

$$= (1/4 b -1/4 b +1/12 b) 1/EJ = 1/12 b/EJ$$

$$L_{AG}^{xx} = \int_0^b (1/4 x^2/b^2) 1/EJ dx = [1/12 x^3/b^2]_0^b 1/EJ$$

$$= (1/12 b) 1/EJ = 1/12 b/EJ$$

$$L_{FG}^{xo} = \int_0^b (5/8 x^2/b^2) Fb 1/EJ dx + \int_0^b (1/2 x/b) \theta dx = [5/24 x^3/b^2]_0^b Fb 1/EJ + [1/4 x^2/b]_0^b \theta$$

$$= (5/24 b) Fb 1/EJ + (1/4 b) \theta = 11/24 Fb^2/EJ$$

$$L_{GF}^{xo} = \int_0^b (5/8 -5/4 x/b +5/8 x^2/b^2) Fb 1/EJ dx + \int_0^b (-1/2 +1/2 x/b) \theta dx$$

$$= [5/8 x -5/8 x^2/b +5/24 x^3/b^2]_0^b Fb 1/EJ + [-1/2 x +1/4 x^2/b]_0^b \theta$$

$$= (5/8 b -5/8 b +5/24 b) Fb 1/EJ + (-1/2 b +1/4 b) \theta = 11/24 Fb^2/EJ$$

$$L_{GD}^{xo} = \int_0^b (1/2 x/b -1/2 x^2/b^2) Fb 1/EJ dx = [1/4 x^2/b -1/6 x^3/b^2]_0^b Fb 1/EJ$$

$$= (1/4 b -1/6 b) Fb 1/EJ = 1/12 Fb^2/EJ$$

$$L_{DG}^{xo} = \int_0^b (1/2 x/b -1/2 x^2/b^2) Fb 1/EJ dx = [1/4 x^2/b -1/6 x^3/b^2]_0^b Fb 1/EJ$$

$$= (1/4 b -1/6 b) Fb 1/EJ = 1/12 Fb^2/EJ$$

$$L_{GA}^{xo} = \int_0^b (-5/8 + x/b -1/8 x^2/b^2 -1/4 x^3/b^3) Fb 1/EJ dx$$

$$= [-5/8 x +1/2 x^2/b -1/24 x^3/b^2 -1/16 x^4/b^3]_0^b Fb 1/EJ$$

$$= (-5/8 b +1/2 b -1/24 b -1/16 b) Fb 1/EJ = -11/48 Fb^2/EJ$$

$$L_{AG}^{xo} = \int_0^b (-7/8 x^2/b^2 +1/4 x^3/b^3) Fb 1/EJ dx = [-7/24 x^3/b^2 +1/16 x^4/b^3]_0^b Fb 1/EJ$$

$$= (-7/24 b +1/16 b) Fb 1/EJ = -11/48 Fb^2/EJ$$

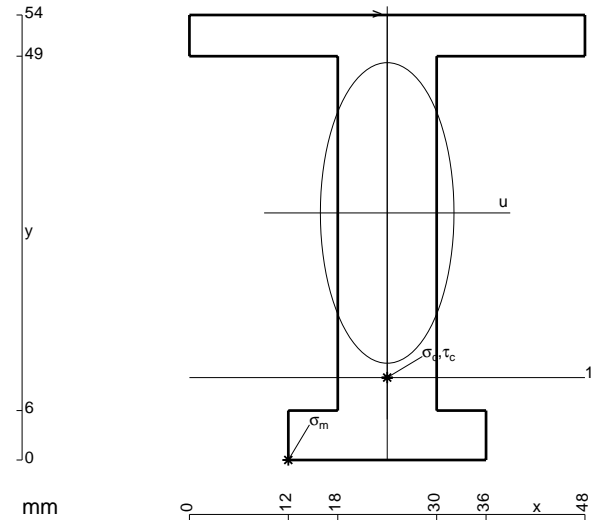

- A = 900. mm²
- J_u = 299580. mm⁴
- J_v = 59184. mm⁴
- y_g = 29.98 mm
- T_y = -2480. N
- M_x = -2380800. Nmm
- x_m = 12. mm
- u_m = -12. mm
- v_m = -29.98 mm
- σ_m = -Mv/J_u = -238.3 N/mm²
- x_c = 24. mm
- y_c = 10. mm
- v_c = -19.98 mm
- σ_c = -Mv/J_u = -158.8 N/mm²
- τ_c = 3.408 N/mm²
- σ_q = √σ²+3τ² = 158.9 N/mm²
- S = 4940. mm³

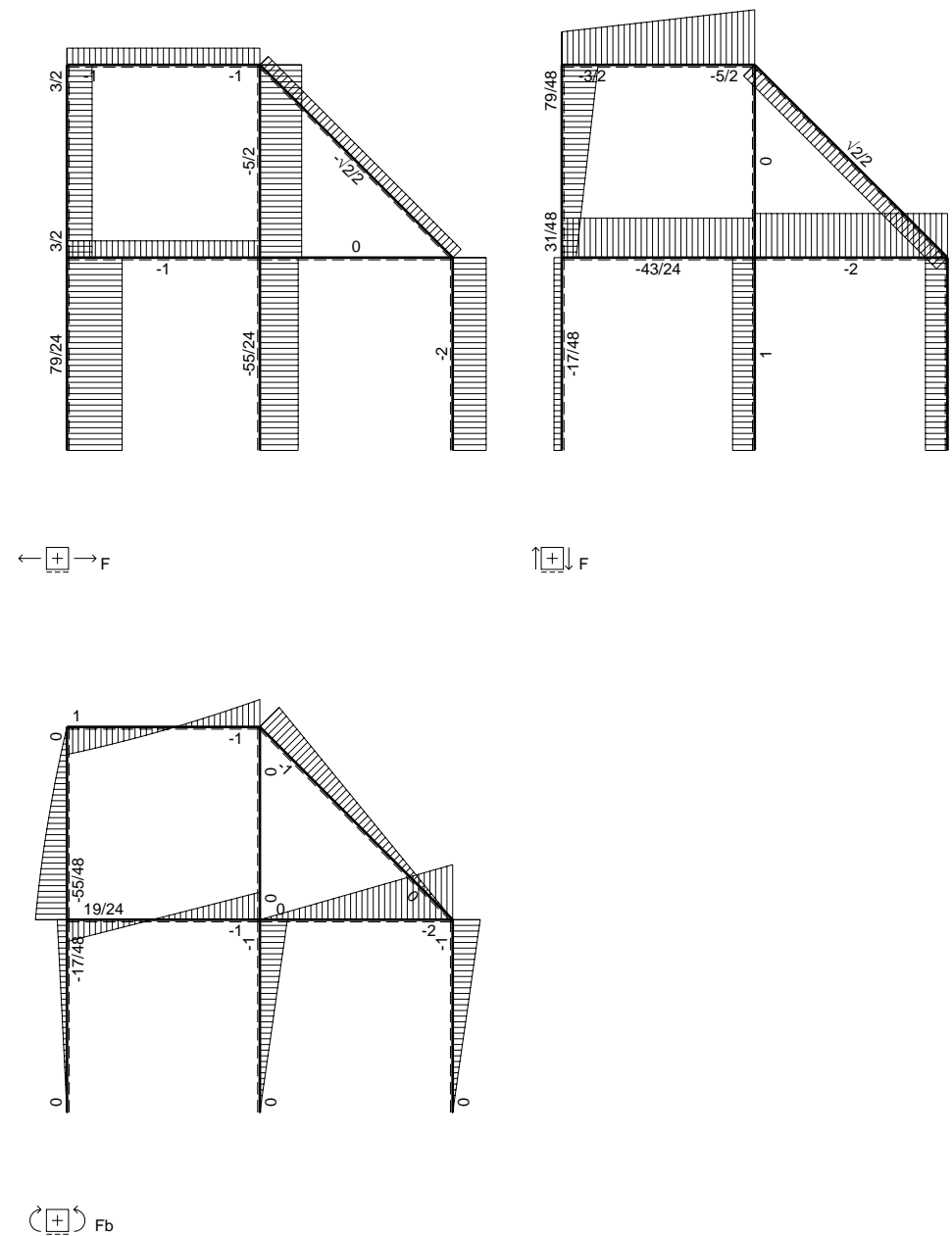
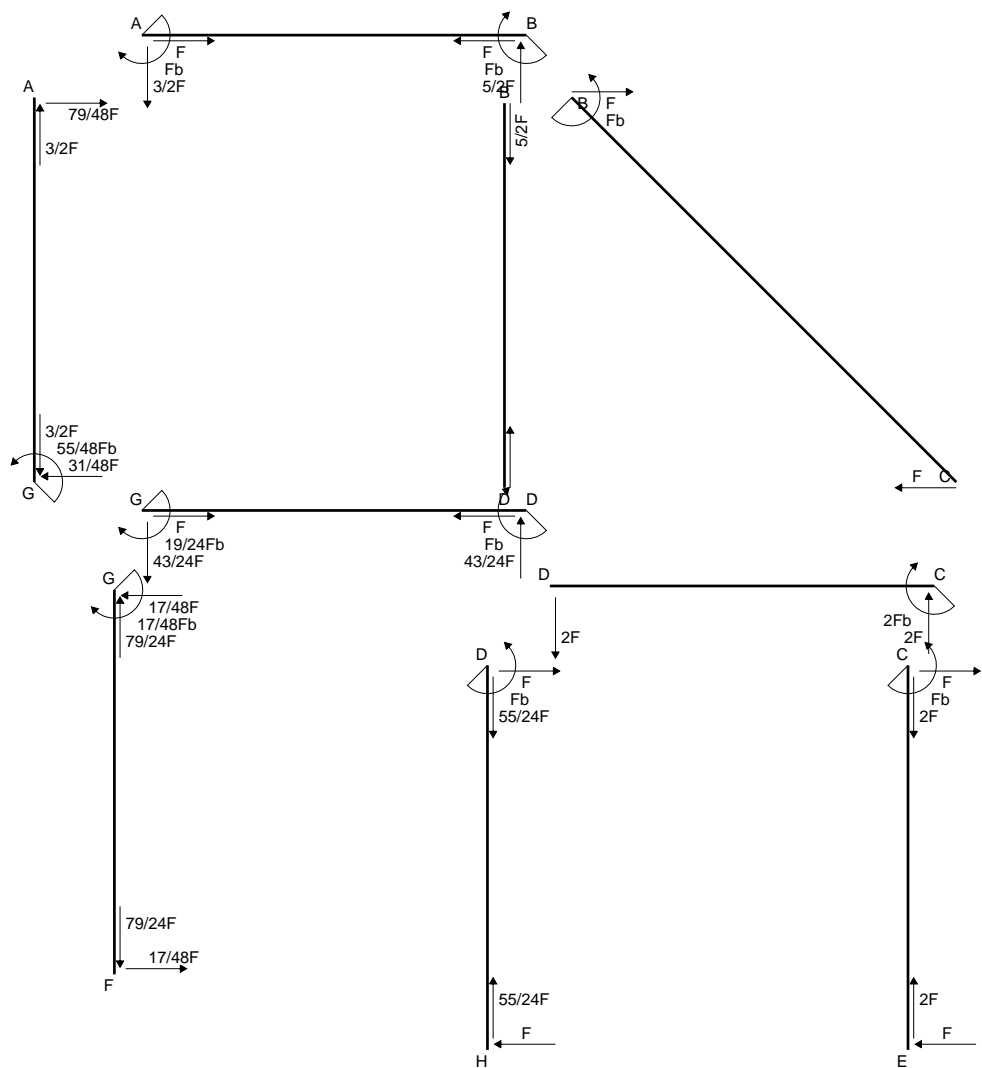

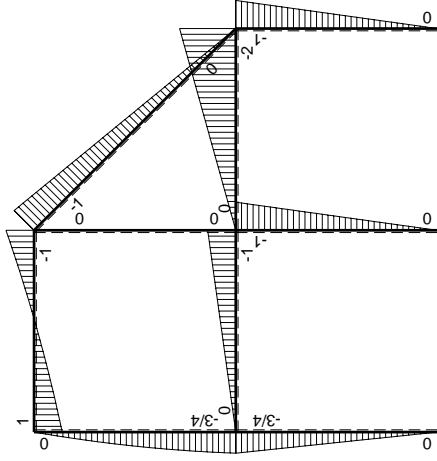
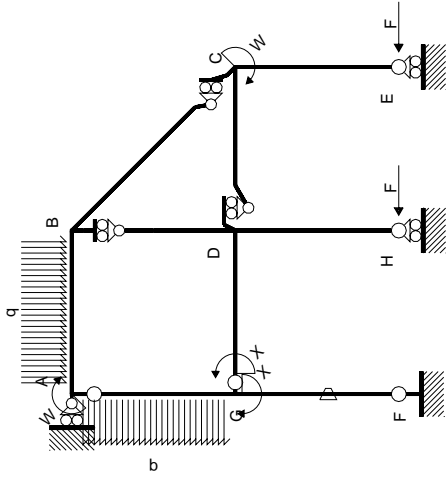

Schema di calcolo iperstatico

M_0 flessione da carichi assegnati

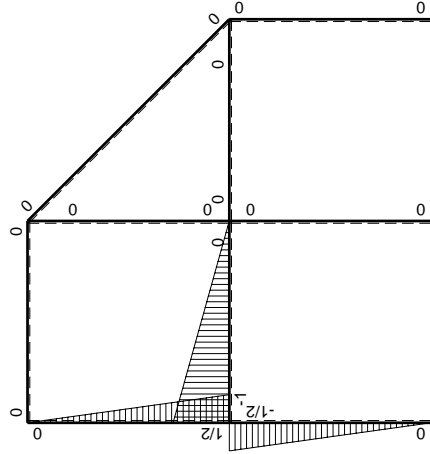

M_x flessione da iperstatica $X=1$

Quadro contributi PLV per iperstatica $X=W_{GD}$

→	$M_x(x)$	$M_o(x)$	θ	$M_x M_o$	$M_x \theta$	$M_x M_x$	$\int M_x(M_o/EJ+\theta)dx$	$\int X M_x M_x/EJ dx$	
AB b	0	$Fb-3/2Fx-1/2qx^2$	0	0	0	0	0+0	0	
BA b	0	$Fb-5/2Fx+1/2qx^2$	0	0	0	0	0	0	
BC $\sqrt{2}b$	0	$-Fb+\sqrt{2}/2Fx$	0	0	0	0	0	0	
BD b	0	0	0	0	0	0	0+0	0	
DB b	0	0	0	0	0	0	0	0	
DC b	0	$-2Fx$	0	0	0	0	0+0	0	
CD b	0	$2Fb-2Fx$	0	0	0	0	0	0	
CE b	0	$-Fb+Fx$	0	0	0	0	0+0	0	
EC b	0	Fx	0	0	0	0	0	0	
FG b	$-1/2x/b$	$-3/4Fx$	$-Fb/EJ$	$3/8Fx^2/b$	$1/2Fx/EJ$	$1/4x^2/b^2$	$(1/8+1/4)Fb^2/EJ$	$1/12Xb/EJ$	
GF b	$1/2-1/2x/b$	$3/4Fb-3/4Fx$	Fb/EJ	$3/8Fb-3/4Fx+3/8Fx^2/b$	$1/2Fb/EJ-1/2Fx/EJ$	$1/4-1/2x/b+1/4x^2/b^2$			
GD b	$-1+x/b$	$-Fx$	0	$Fx-Fx^2/b$	0	$1-2x/b+x^2/b^2$	$(1/6+0)Fb^2/EJ$	$1/3Xb/EJ$	
DG b	x/b	$Fb-Fx$	0	$Fx-Fx^2/b$	0	x^2/b^2			
DH b	0	$-Fb+Fx$	0	0	0	0	0+0	0	
HD b	0	Fx	0	0	0	0			
GA b	$1/2-1/2x/b$	$-3/4Fb+1/4Fx+1/2qx^2$	0	$-3/8Fb+1/2Fx+1/8Fx^2/b-1/4qx^3/b$	0	$1/4-1/2x/b+1/4x^2/b^2$	$(-7/48+0)Fb^2/EJ$	$1/12Xb/EJ$	
AG b	$-1/2x/b$	$5/4Fx-1/2qx^2$	0	$-5/8Fx^2/b+1/4qx^3/b$	0	$1/4x^2/b^2$			
	totali							$19/48Fb^2/EJ$	$1/2Xb/EJ$
	iperstatica $X=W_{GD}$							$-19/24Fb$	

Sviluppi di calcolo iperstatica

$$L_{FG}^{xx} = \int_0^b (1/4 x^2/b^2) 1/EJ dx = [1/12 x^3/b^2]_0^b 1/EJ$$

$$= (1/12 b) 1/EJ = 1/12 b/EJ$$

$$L_{GF}^{xx} = \int_0^b (1/4 - 1/2 x/b + 1/4 x^2/b^2) 1/EJ dx = [1/4 x - 1/4 x^2/b + 1/12 x^3/b^2]_0^b 1/EJ$$

$$= (1/4 b - 1/4 b + 1/12 b) 1/EJ = 1/12 b/EJ$$

$$L_{GD}^{xx} = \int_0^b (1 - 2 x/b + x^2/b^2) 1/EJ dx = [x - x^2/b + 1/3 x^3/b^2]_0^b 1/EJ$$

$$= (b - b + 1/3 b) 1/EJ = 1/3 b/EJ$$

$$L_{DG}^{xx} = \int_0^b (x^2/b^2) 1/EJ dx = [1/3 x^3/b^2]_0^b 1/EJ$$

$$= (1/3 b) 1/EJ = 1/3 b/EJ$$

$$L_{GA}^{xx} = \int_0^b (1/4 - 1/2 x/b + 1/4 x^2/b^2) 1/EJ dx = [1/4 x - 1/4 x^2/b + 1/12 x^3/b^2]_0^b 1/EJ$$

$$= (1/4 b - 1/4 b + 1/12 b) 1/EJ = 1/12 b/EJ$$

$$L_{AG}^{xx} = \int_0^b (1/4 x^2/b^2) 1/EJ dx = [1/12 x^3/b^2]_0^b 1/EJ$$

$$= (1/12 b) 1/EJ = 1/12 b/EJ$$

$$L_{FG}^{xo} = \int_0^b (3/8 x^2/b^2) Fb 1/EJ dx + \int_0^b (1/2 x/b) \theta dx = [1/8 x^3/b^2]_0^b Fb 1/EJ + [1/4 x^2/b]_0^b \theta$$

$$= (1/8 b) Fb 1/EJ + (1/4 b) \theta = 3/8 Fb^2/EJ$$

$$L_{GF}^{xo} = \int_0^b (3/8 - 3/4 x/b + 3/8 x^2/b^2) Fb 1/EJ dx + \int_0^b (-1/2 + 1/2 x/b) \theta dx$$

$$= [3/8 x - 3/8 x^2/b + 1/8 x^3/b^2]_0^b Fb 1/EJ + [-1/2 x + 1/4 x^2/b]_0^b \theta$$

$$= (3/8 b - 3/8 b + 1/8 b) Fb 1/EJ + (-1/2 b + 1/4 b) \theta = 3/8 Fb^2/EJ$$

$$L_{GD}^{xo} = \int_0^b (x/b - x^2/b^2) Fb 1/EJ dx = [1/2 x^2/b - 1/3 x^3/b^2]_0^b Fb 1/EJ$$

$$= (1/2 b - 1/3 b) Fb 1/EJ = 1/6 Fb^2/EJ$$

$$L_{DG}^{xo} = \int_0^b (x/b - x^2/b^2) Fb 1/EJ dx = [1/2 x^2/b - 1/3 x^3/b^2]_0^b Fb 1/EJ$$

$$= (1/2 b - 1/3 b) Fb 1/EJ = 1/6 Fb^2/EJ$$

$$L_{GA}^{xo} = \int_0^b (-3/8 + 1/2 x/b + 1/8 x^2/b^2 - 1/4 x^3/b^3) Fb 1/EJ dx$$

$$= [-3/8 x + 1/4 x^2/b + 1/24 x^3/b^2 - 1/16 x^4/b^3]_0^b Fb 1/EJ$$

$$= (-3/8 b + 1/4 b + 1/24 b - 1/16 b) Fb 1/EJ = -7/48 Fb^2/EJ$$

$$L_{AG}^{xo} = \int_0^b (-5/8 x^2/b^2 + 1/4 x^3/b^3) Fb 1/EJ dx = [-5/24 x^3/b^2 + 1/16 x^4/b^3]_0^b Fb 1/EJ$$

$$= (-5/24 b + 1/16 b) Fb 1/EJ = -7/48 Fb^2/EJ$$

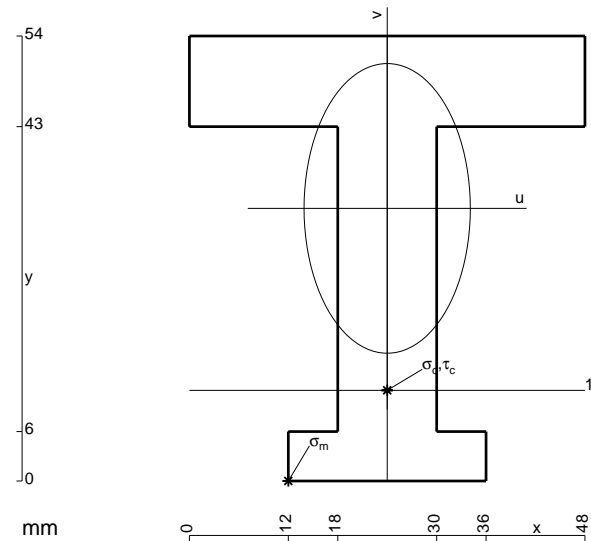

- A = 1116. mm²
- J_u = 344933. mm⁴
- J_v = 113616. mm⁴
- y_g = 33.08 mm
- T_y = -4080. N
- M_x = -2080800. Nmm
- x_m = 12. mm
- u_m = -12. mm
- v_m = -33.08 mm
- σ_m = -Mv/J_u = -199.6 N/mm²
- x_c = 24. mm
- y_c = 11. mm
- v_c = -22.08 mm
- σ_c = -Mv/J_u = -133.2 N/mm²
- τ_c = 5.723 N/mm²
- σ_q = √σ² + 3τ² = 133.6 N/mm²
- S = 5806. mm³

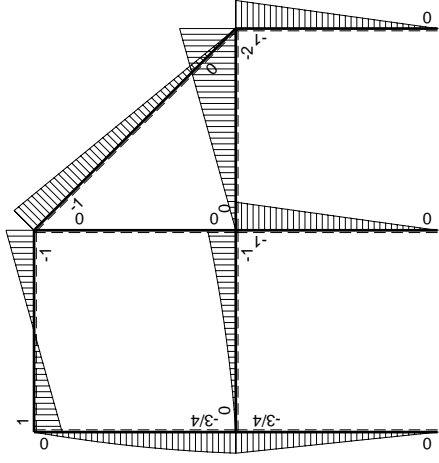
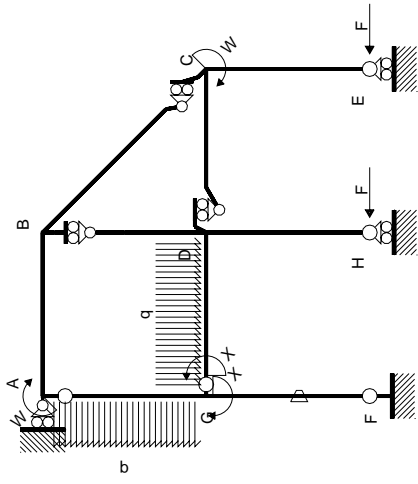

Schema di calcolo iperstatico

M_0 flessione da carichi assegnati

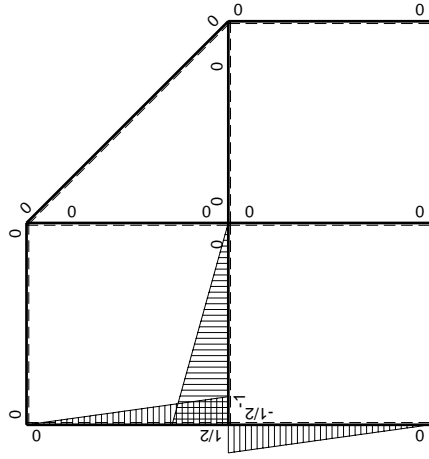

M_1 flessione da iperstatica $X=1$

Quadro contributi PLV per iperstatica $X=W_{GD}$

→	$M_x(x)$	$M_o(x)$	θ	$M_x M_o$	$M_x \theta$	$M_x M_x$	$\int M_x(M_o/EJ+\theta)dx$	$\int X M_x M_x/EJ dx$	
AB b	0	Fb-2Fx	0	0	0	0	0+0	0	
BA b	0	Fb-2Fx	0	0	0	0	0	0	
BC $\sqrt{2}b$	0	-Fb+ $\sqrt{2}/2Fx$	0	0	0	0	0	0	
BD b	0	0	0	0	0	0	0+0	0	
DB b	0	0	0	0	0	0	0	0	
DC b	0	-2Fx	0	0	0	0	0+0	0	
CD b	0	2Fb-2Fx	0	0	0	0	0	0	
CE b	0	-Fb+Fx	0	0	0	0	0+0	0	
EC b	0	Fx	0	0	0	0	0	0	
FG b	-1/2x/b	-3/4Fx	-Fb/EJ	3/8Fx ² /b	1/2Fx/EJ	1/4x ² /b ²	(1/8+1/4)Fb ² /EJ	1/12Xb/EJ	
GF b	1/2-1/2x/b	3/4Fb-3/4Fx	Fb/EJ	3/8Fb-3/4Fx+3/8Fx ² /b	1/2Fb/EJ-1/2Fx/EJ	1/4-1/2x/b+1/4x ² /b ²			
GD b	-1+x/b	-1/2Fx-1/2qx ²	0	1/2Fx-1/2qx ³ /b	0	1-2x/b+x ² /b ²	(1/8+0)Fb ² /EJ	1/3Xb/EJ	
DG b	x/b	Fb-3/2Fx+1/2qx ²	0	Fx-3/2Fx ² /b+1/2qx ³ /b	0	x ² /b ²			
DH b	0	-Fb+Fx	0	0	0	0	0+0	0	
HD b	0	Fx	0	0	0	0	0	0	
GA b	1/2-1/2x/b	-3/4Fb+1/4Fx+1/2qx ²	0	-3/8Fb+1/2Fx+1/8Fx ² /b-1/4qx ³ /b	0	1/4-1/2x/b+1/4x ² /b ²	(-7/48+0)Fb ² /EJ	1/12Xb/EJ	
AG b	-1/2x/b	5/4Fx-1/2qx ²	0	-5/8Fx ² /b+1/4qx ³ /b	0	1/4x ² /b ²			
	totali							17/48Fb ² /EJ	1/2Xb/EJ
	iperstatica $X=W_{GD}$							-17/24Fb	

Sviluppi di calcolo iperstatica

$$L_{FG}^{xx} = \int_0^b (1/4 x^2/b^2) 1/EJ dx = [1/12 x^3/b^2]_0^b 1/EJ$$

$$= (1/12 b) 1/EJ = 1/12 b/EJ$$

$$L_{GF}^{xx} = \int_0^b (1/4 - 1/2 x/b + 1/4 x^2/b^2) 1/EJ dx = [1/4 x - 1/4 x^2/b + 1/12 x^3/b^2]_0^b 1/EJ$$

$$= (1/4 b - 1/4 b + 1/12 b) 1/EJ = 1/12 b/EJ$$

$$L_{GD}^{xx} = \int_0^b (1 - 2 x/b + x^2/b^2) 1/EJ dx = [x - x^2/b + 1/3 x^3/b^2]_0^b 1/EJ$$

$$= (b - b + 1/3 b) 1/EJ = 1/3 b/EJ$$

$$L_{DG}^{xx} = \int_0^b (x^2/b^2) 1/EJ dx = [1/3 x^3/b^2]_0^b 1/EJ$$

$$= (1/3 b) 1/EJ = 1/3 b/EJ$$

$$L_{GA}^{xx} = \int_0^b (1/4 - 1/2 x/b + 1/4 x^2/b^2) 1/EJ dx = [1/4 x - 1/4 x^2/b + 1/12 x^3/b^2]_0^b 1/EJ$$

$$= (1/4 b - 1/4 b + 1/12 b) 1/EJ = 1/12 b/EJ$$

$$L_{AG}^{xx} = \int_0^b (1/4 x^2/b^2) 1/EJ dx = [1/12 x^3/b^2]_0^b 1/EJ$$

$$= (1/12 b) 1/EJ = 1/12 b/EJ$$

$$L_{FG}^{x_0} = \int_0^b (3/8 x^2/b^2) Fb 1/EJ dx + \int_0^b (1/2 x/b) \theta dx = [1/8 x^3/b^2]_0^b Fb 1/EJ + [1/4 x^2/b]_0^b \theta$$

$$= (1/8 b) Fb 1/EJ + (1/4 b) \theta = 3/8 Fb^2/EJ$$

$$L_{GF}^{x_0} = \int_0^b (3/8 - 3/4 x/b + 3/8 x^2/b^2) Fb 1/EJ dx + \int_0^b (-1/2 + 1/2 x/b) \theta dx$$

$$= [3/8 x - 3/8 x^2/b + 1/8 x^3/b^2]_0^b Fb 1/EJ + [-1/2 x + 1/4 x^2/b]_0^b \theta$$

$$= (3/8 b - 3/8 b + 1/8 b) Fb 1/EJ + (-1/2 b + 1/4 b) \theta = 3/8 Fb^2/EJ$$

$$L_{GD}^{x_0} = \int_0^b (1/2 x/b - 1/2 x^3/b^3) Fb 1/EJ dx = [1/4 x^2/b - 1/8 x^4/b^3]_0^b Fb 1/EJ$$

$$= (1/4 b - 1/8 b) Fb 1/EJ = 1/8 Fb^2/EJ$$

$$L_{DG}^{x_0} = \int_0^b (x/b - 3/2 x^2/b^2 + 1/2 x^3/b^3) Fb 1/EJ dx = [1/2 x^2/b - 1/2 x^3/b^2 + 1/8 x^4/b^3]_0^b Fb 1/EJ$$

$$= (1/2 b - 1/2 b + 1/8 b) Fb 1/EJ = 1/8 Fb^2/EJ$$

$$L_{GA}^{x_0} = \int_0^b (-3/8 + 1/2 x/b + 1/8 x^2/b^2 - 1/4 x^3/b^3) Fb 1/EJ dx$$

$$= [-3/8 x + 1/4 x^2/b + 1/24 x^3/b^2 - 1/16 x^4/b^3]_0^b Fb 1/EJ$$

$$= (-3/8 b + 1/4 b + 1/24 b - 1/16 b) Fb 1/EJ = -7/48 Fb^2/EJ$$

$$L_{AG}^{x_0} = \int_0^b (-5/8 x^2/b^2 + 1/4 x^3/b^3) Fb 1/EJ dx = [-5/24 x^3/b^2 + 1/16 x^4/b^3]_0^b Fb 1/EJ$$

$$= (-5/24 b + 1/16 b) Fb 1/EJ = -7/48 Fb^2/EJ$$

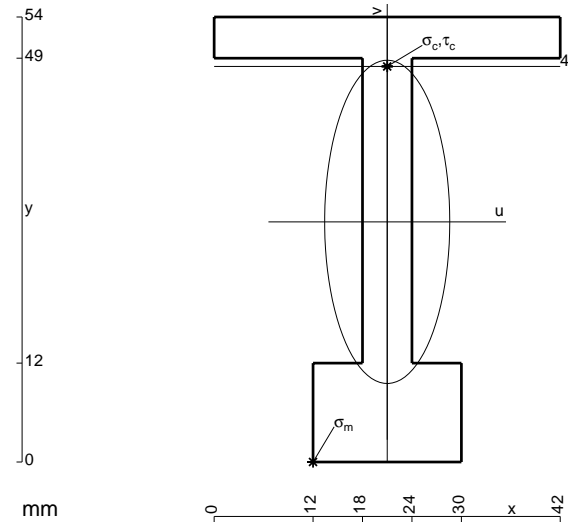

$$A = 648. \text{ mm}^2$$

$$J_u = 249419. \text{ mm}^4$$

$$J_v = 37368. \text{ mm}^4$$

$$y_g = 29.14 \text{ mm}$$

$$T_y = -3200. \text{ N}$$

$$M_x = -1792000. \text{ Nmm}$$

$$x_m = 12. \text{ mm}$$

$$u_m = -9. \text{ mm}$$

$$v_m = -29.14 \text{ mm}$$

$$\sigma_m = -Mv/J_u = -209.4 \text{ N/mm}^2$$

$$x_c = 21. \text{ mm}$$

$$y_c = 48. \text{ mm}$$

$$v_c = 18.86 \text{ mm}$$

$$\sigma_c = -Mv/J_u = 135.5 \text{ N/mm}^2$$

$$\tau_c = 10.29 \text{ N/mm}^2$$

$$\sigma_q = \sqrt{\sigma^2 + 3\tau^2} = 136.7 \text{ N/mm}^2$$

$$S = 4812. \text{ mm}^3$$

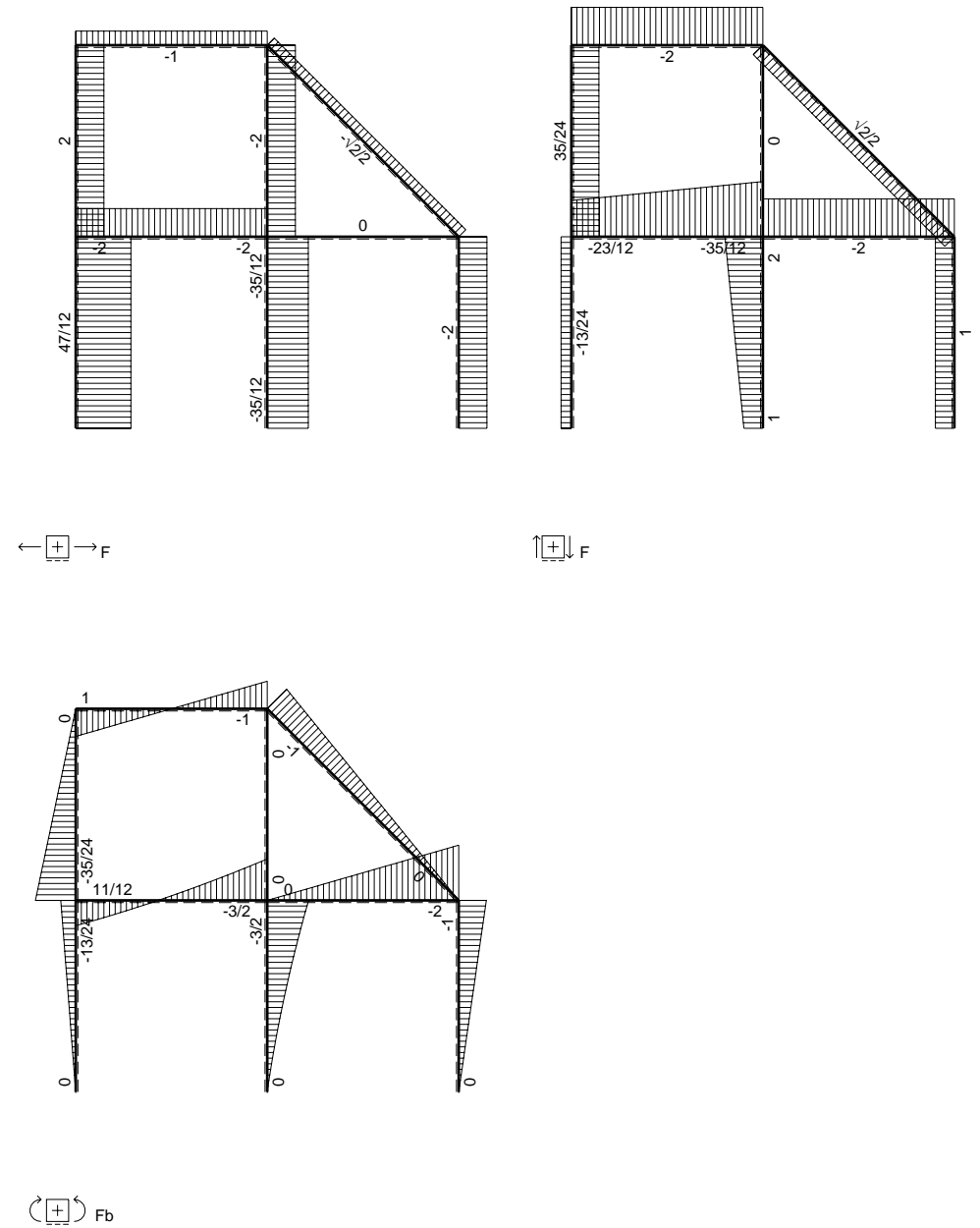
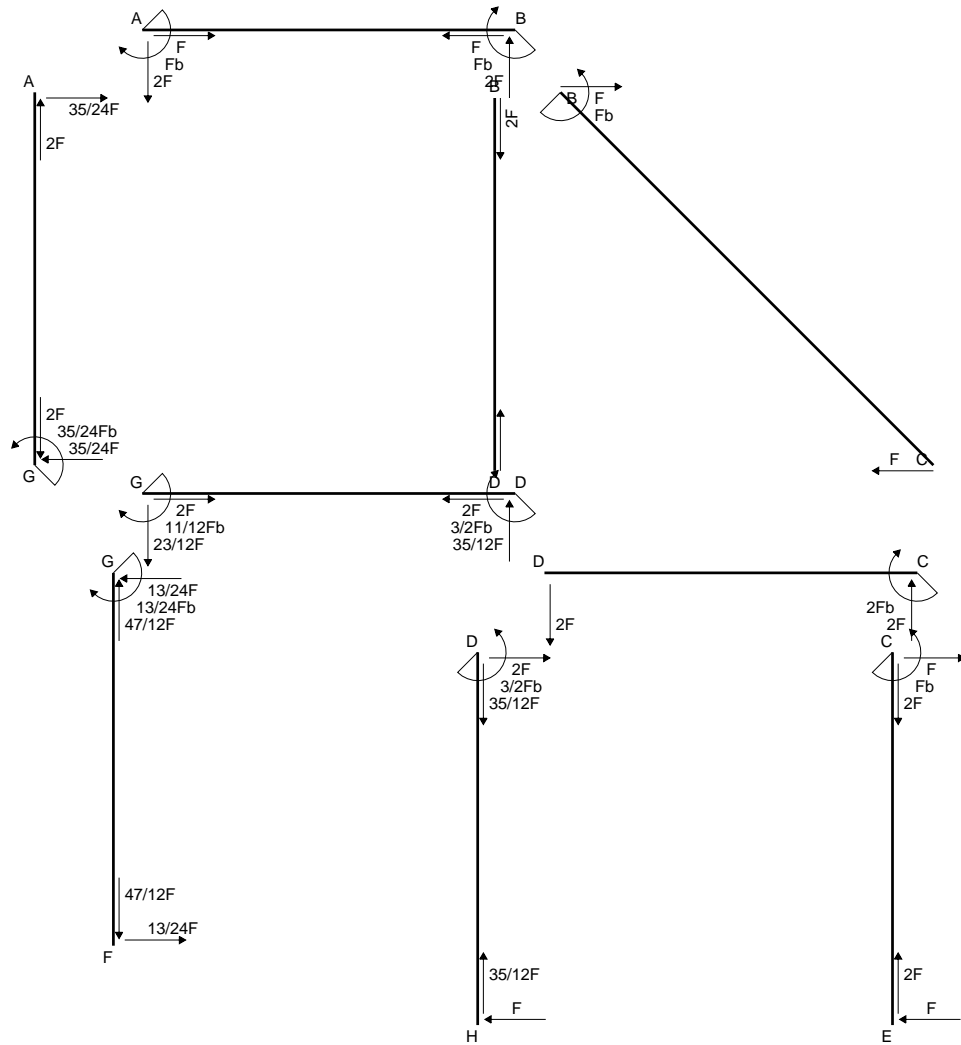

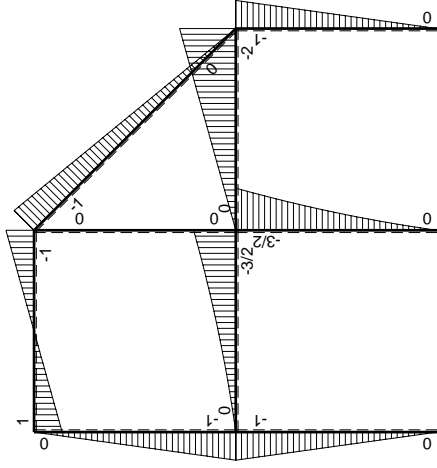
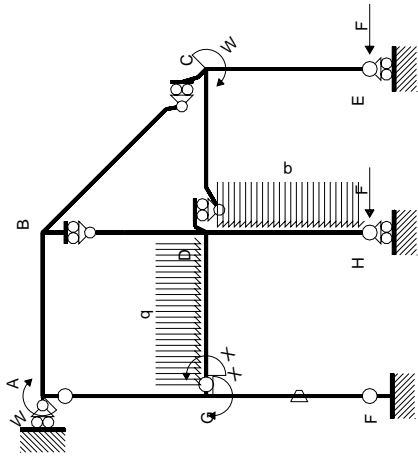

Schema di calcolo iperstatico

M_0 , flessione da carichi assegnati

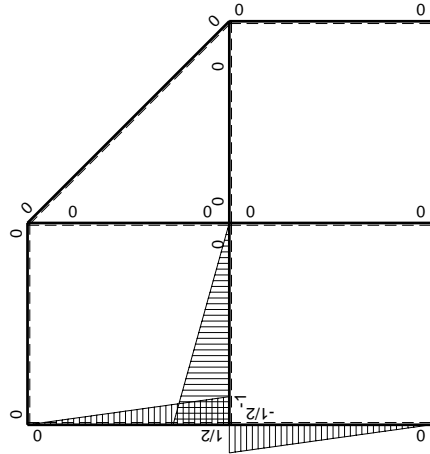

M_x , flessione da iperstatica $X=1$

Quadro contributi PLV per iperstatica $X=W_{GD}$

→	$M_x(x)$	$M_o(x)$	θ	$M_x M_o$	$M_x \theta$	$M_x M_x$	$\int M_x(M_o/EJ+\theta)dx$	$\int X M_x M_x/EJdx$
AB b	0	Fb-2Fx	0	0	0	0	0+0	0
BA b	0	Fb-2Fx	0	0	0	0	0	0
BC $\sqrt{2}b$	0	-Fb+ $\sqrt{2}/2Fx$	0	0	0	0	0	0
BD b	0	0	0	0	0	0	0+0	0
DB b	0	0	0	0	0	0	0	0
DC b	0	-2Fx	0	0	0	0	0+0	0
CD b	0	2Fb-2Fx	0	0	0	0	0	0
CE b	0	-Fb+Fx	0	0	0	0	0+0	0
EC b	0	Fx	0	0	0	0	0	0
FG b	-1/2x/b	-Fx	-Fb/EJ	1/2Fx ² /b	1/2Fx/EJ	1/4x ² /b ²	(1/6+1/4)Fb ² /EJ	1/12Xb/EJ
GF b	1/2-1/2x/b	Fb-Fx	Fb/EJ	1/2Fb-Fx+1/2Fx ² /b	1/2Fb/EJ-1/2Fx/EJ	1/4-1/2x/b+1/4x ² /b ²		
GD b	-1+x/b	-Fx-1/2qx ²	0	Fx-1/2Fx ² /b-1/2qx ³ /b	0	1-2x/b+x ² /b ²	(5/24+0)Fb ² /EJ	1/3Xb/EJ
DG b	x/b	3/2Fb-2Fx+1/2qx ²	0	3/2Fx-2Fx ² /b+1/2qx ³ /b	0	x ² /b ²		
DH b	0	-3/2Fb+2Fx-1/2qx ²	0	0	0	0	0+0	0
HD b	0	Fx+1/2qx ²	0	0	0	0		
GA b	1/2-1/2x/b	-Fb+Fx	0	-1/2Fb+Fx-1/2Fx ² /b	0	1/4-1/2x/b+1/4x ² /b ²	(-1/6+0)Fb ² /EJ	1/12Xb/EJ
AG b	-1/2x/b	Fx	0	-1/2Fx ² /b	0	1/4x ² /b ²		
	totali						11/24Fb ² /EJ	1/2Xb/EJ
	iperstatica $X=W_{GD}$						-11/12Fb	

Sviluppi di calcolo iperstatica

$$L_{FG}^{xx} = \int_0^b (1/4 x^2/b^2) 1/EJ dx = [1/12 x^3/b^2]_0^b 1/EJ$$

$$= (1/12 b) 1/EJ = 1/12 b/EJ$$

$$L_{GF}^{xx} = \int_0^b (1/4 - 1/2 x/b + 1/4 x^2/b^2) 1/EJ dx = [1/4 x - 1/4 x^2/b + 1/12 x^3/b^2]_0^b 1/EJ$$

$$= (1/4 b - 1/4 b + 1/12 b) 1/EJ = 1/12 b/EJ$$

$$L_{GD}^{xx} = \int_0^b (1 - 2 x/b + x^2/b^2) 1/EJ dx = [x - x^2/b + 1/3 x^3/b^2]_0^b 1/EJ$$

$$= (b - b + 1/3 b) 1/EJ = 1/3 b/EJ$$

$$L_{DG}^{xx} = \int_0^b (x^2/b^2) 1/EJ dx = [1/3 x^3/b^2]_0^b 1/EJ$$

$$= (1/3 b) 1/EJ = 1/3 b/EJ$$

$$L_{GA}^{xx} = \int_0^b (1/4 - 1/2 x/b + 1/4 x^2/b^2) 1/EJ dx = [1/4 x - 1/4 x^2/b + 1/12 x^3/b^2]_0^b 1/EJ$$

$$= (1/4 b - 1/4 b + 1/12 b) 1/EJ = 1/12 b/EJ$$

$$L_{AG}^{xx} = \int_0^b (1/4 x^2/b^2) 1/EJ dx = [1/12 x^3/b^2]_0^b 1/EJ$$

$$= (1/12 b) 1/EJ = 1/12 b/EJ$$

$$L_{FG}^{xo} = \int_0^b (1/2 x^2/b^2) Fb 1/EJ dx + \int_0^b (1/2 x/b) \theta dx = [1/6 x^3/b^2]_0^b Fb 1/EJ + [1/4 x^2/b]_0^b \theta$$

$$= (1/6 b) Fb 1/EJ + (1/4 b) \theta = 5/12 Fb^2/EJ$$

$$L_{GF}^{xo} = \int_0^b (1/2 - x/b + 1/2 x^2/b^2) Fb 1/EJ dx + \int_0^b (-1/2 + 1/2 x/b) \theta dx$$

$$= [1/2 x - 1/2 x^2/b + 1/6 x^3/b^2]_0^b Fb 1/EJ + [-1/2 x + 1/4 x^2/b]_0^b \theta$$

$$= (1/2 b - 1/2 b + 1/6 b) Fb 1/EJ + (-1/2 b + 1/4 b) \theta = 5/12 Fb^2/EJ$$

$$L_{GD}^{xo} = \int_0^b (x/b - 1/2 x^2/b^2 - 1/2 x^3/b^3) Fb 1/EJ dx = [1/2 x^2/b - 1/6 x^3/b^2 - 1/8 x^4/b^3]_0^b Fb 1/EJ$$

$$= (1/2 b - 1/6 b - 1/8 b) Fb 1/EJ = 5/24 Fb^2/EJ$$

$$L_{DG}^{xo} = \int_0^b (3/2 x/b - 2 x^2/b^2 + 1/2 x^3/b^3) Fb 1/EJ dx = [3/4 x^2/b - 2/3 x^3/b^2 + 1/8 x^4/b^3]_0^b Fb 1/EJ$$

$$= (3/4 b - 2/3 b + 1/8 b) Fb 1/EJ = 5/24 Fb^2/EJ$$

$$L_{GA}^{xo} = \int_0^b (-1/2 + x/b - 1/2 x^2/b^2) Fb 1/EJ dx = [-1/2 x + 1/2 x^2/b - 1/6 x^3/b^2]_0^b Fb 1/EJ$$

$$= (-1/2 b + 1/2 b - 1/6 b) Fb 1/EJ = -1/6 Fb^2/EJ$$

$$L_{AG}^{xo} = \int_0^b (-1/2 x^2/b^2) Fb 1/EJ dx = [-1/6 x^3/b^2]_0^b Fb 1/EJ$$

$$= (-1/6 b) Fb 1/EJ = -1/6 Fb^2/EJ$$

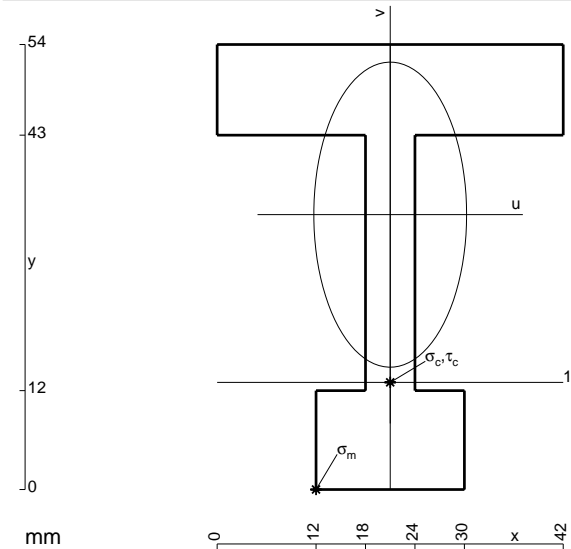

$A = 864. \text{ mm}^2$
 $J_u = 296124. \text{ mm}^4$
 $J_v = 74304. \text{ mm}^4$
 $y_g = 33.35 \text{ mm}$
 $T_y = -3200. \text{ N}$
 $M_x = -1952000. \text{ Nmm}$
 $x_m = 12. \text{ mm}$
 $u_m = -9. \text{ mm}$
 $v_m = -33.35 \text{ mm}$
 $\sigma_m = -Mv/J_u = -219.9 \text{ N/mm}^2$
 $x_c = 21. \text{ mm}$
 $y_c = 13. \text{ mm}$
 $v_c = -20.35 \text{ mm}$
 $\sigma_c = -Mv/J_u = -134.2 \text{ N/mm}^2$
 $\tau_c = 10.87 \text{ N/mm}^2$
 $\sigma_o = \sqrt{\sigma^2 + 3\tau^2} = 135.5 \text{ N/mm}^2$
 $S = 6034. \text{ mm}^3$

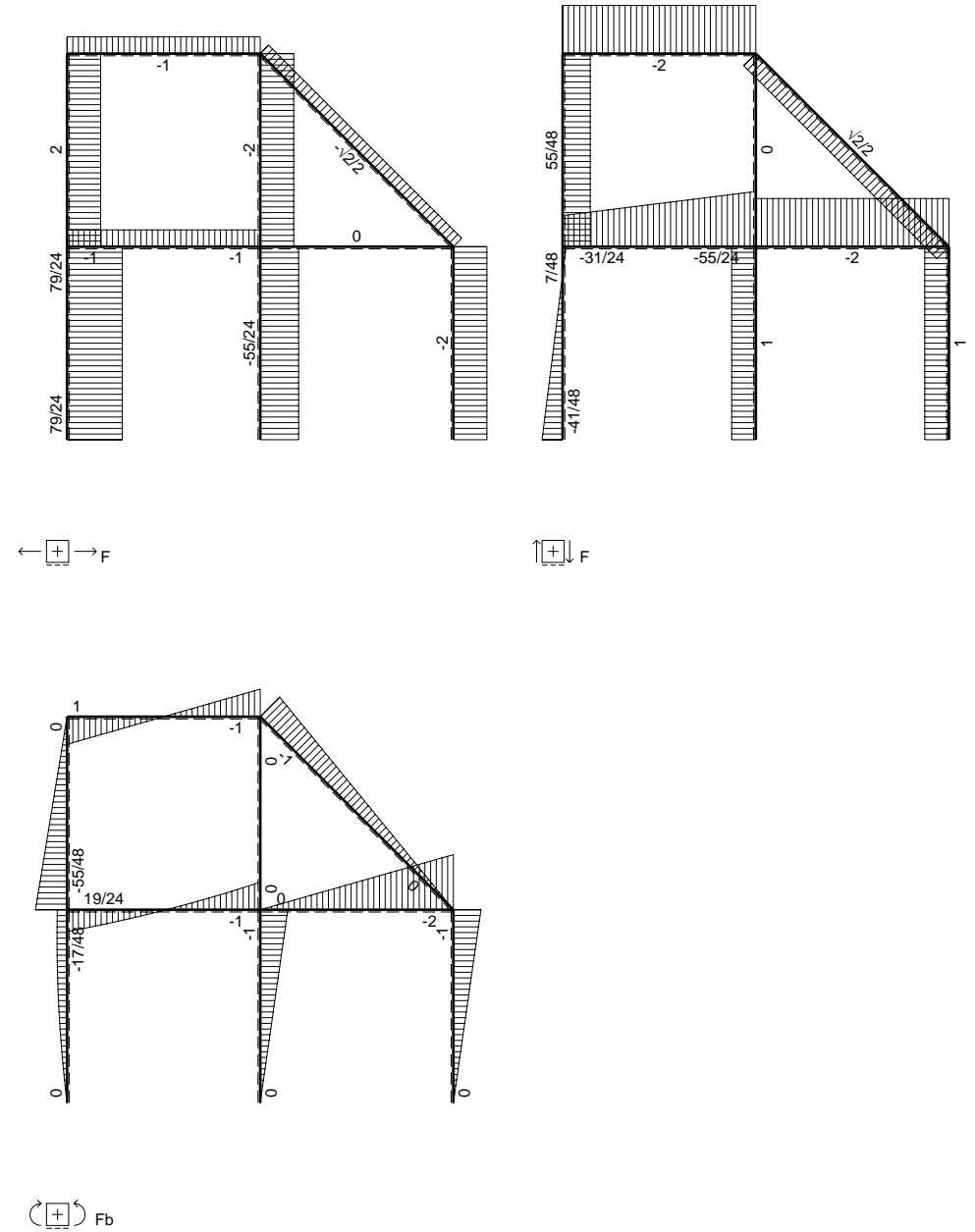
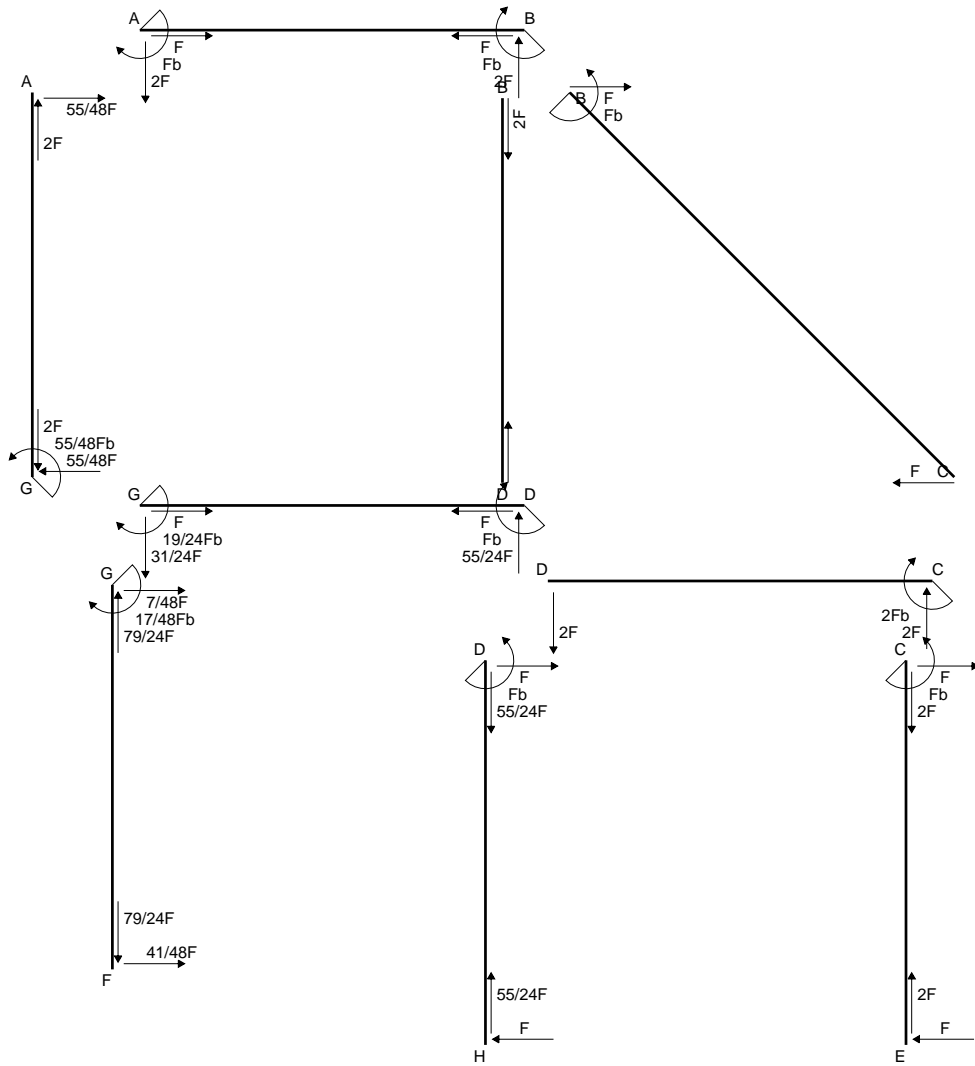

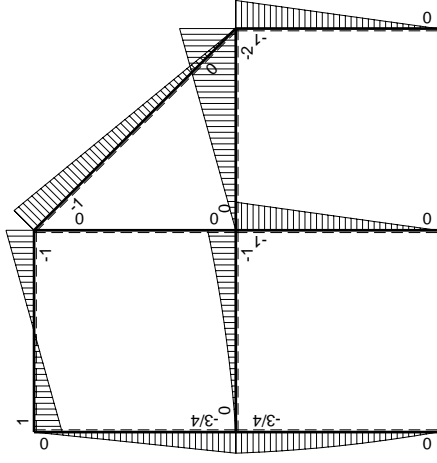
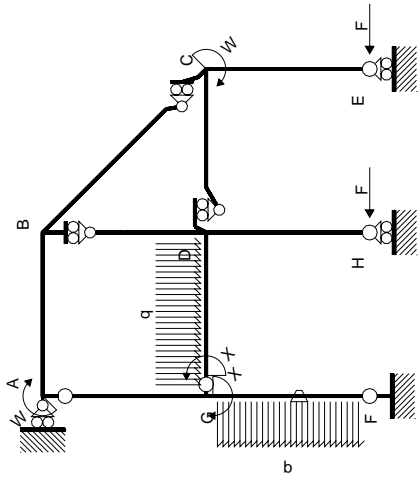

Schema di calcolo iperstatico

M_0 flessione da carichi assegnati

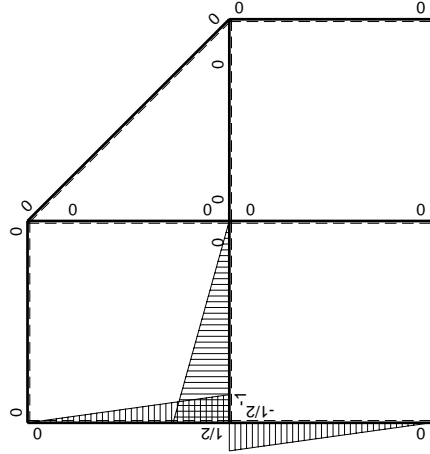

M_x flessione da iperstatica $X=1$

Quadro contributi PLV per iperstatica $X=W_{GD}$

→	$M_x(x)$	$M_o(x)$	θ	$M_x M_o$	$M_x \theta$	$M_x M_x$	$\int M_x(M_o/EJ+\theta)dx$	$\int x M_x M_x/EJ dx$
AB b	0	Fb-2Fx	0	0	0	0	0+0	0
BA b	0	Fb-2Fx	0	0	0	0	0	0
BC $\sqrt{2}b$	0	-Fb+ $\sqrt{2}/2Fx$	0	0	0	0	0	0
BD b	0	0	0	0	0	0	0+0	0
DB b	0	0	0	0	0	0	0	0
DC b	0	-2Fx	0	0	0	0	0+0	0
CD b	0	2Fb-2Fx	0	0	0	0	0	0
CE b	0	-Fb+Fx	0	0	0	0	0+0	0
EC b	0	Fx	0	0	0	0	0	0
FG b	-1/2x/b	-5/4Fx+1/2qx ²	-Fb/EJ	5/8Fx ² /b-1/4qx ³ /b	1/2Fx/EJ	1/4x ² /b ²	(7/48+1/4)Fb ² /EJ	1/12Xb/EJ
GF b	1/2-1/2x/b	3/4Fb-1/4Fx-1/2qx ²	Fb/EJ	3/8Fb-1/2Fx-1/8Fx ² /b+1/4qx ³ /b	1/2Fb/EJ-1/2Fx/EJ	1/4-1/2x/b+1/4x ² /b ²		
GD b	-1+x/b	-1/2Fx-1/2qx ²	0	1/2Fx-1/2qx ³ /b	0	1-2x/b+x ² /b ²	(1/8+0)Fb ² /EJ	1/3Xb/EJ
DG b	x/b	Fb-3/2Fx+1/2qx ²	0	Fx-3/2Fx ² /b+1/2qx ³ /b	0	x ² /b ²		
DH b	0	-Fb+Fx	0	0	0	0	0+0	0
HD b	0	Fx	0	0	0	0		
GA b	1/2-1/2x/b	-3/4Fb+3/4Fx	0	-3/8Fb+3/4Fx-3/8Fx ² /b	0	1/4-1/2x/b+1/4x ² /b ²	(-1/8+0)Fb ² /EJ	1/12Xb/EJ
AG b	-1/2x/b	3/4Fx	0	-3/8Fx ² /b	0	1/4x ² /b ²		
	totali						19/48Fb ² /EJ	1/2Xb/EJ
	iperstatica $X=W_{GD}$						-19/24Fb	

Sviluppi di calcolo iperstatica

$$L_{FG}^{xx} = \int_0^b (1/4 x^2/b^2) 1/EJ dx = [1/12 x^3/b^2]_0^b 1/EJ$$

$$= (1/12 b) 1/EJ = 1/12 b/EJ$$

$$L_{GF}^{xx} = \int_0^b (1/4 - 1/2 x/b + 1/4 x^2/b^2) 1/EJ dx = [1/4 x - 1/4 x^2/b + 1/12 x^3/b^2]_0^b 1/EJ$$

$$= (1/4 b - 1/4 b + 1/12 b) 1/EJ = 1/12 b/EJ$$

$$L_{GD}^{xx} = \int_0^b (1 - 2 x/b + x^2/b^2) 1/EJ dx = [x - x^2/b + 1/3 x^3/b^2]_0^b 1/EJ$$

$$= (b - b + 1/3 b) 1/EJ = 1/3 b/EJ$$

$$L_{DG}^{xx} = \int_0^b (x^2/b^2) 1/EJ dx = [1/3 x^3/b^2]_0^b 1/EJ$$

$$= (1/3 b) 1/EJ = 1/3 b/EJ$$

$$L_{GA}^{xx} = \int_0^b (1/4 - 1/2 x/b + 1/4 x^2/b^2) 1/EJ dx = [1/4 x - 1/4 x^2/b + 1/12 x^3/b^2]_0^b 1/EJ$$

$$= (1/4 b - 1/4 b + 1/12 b) 1/EJ = 1/12 b/EJ$$

$$L_{AG}^{xx} = \int_0^b (1/4 x^2/b^2) 1/EJ dx = [1/12 x^3/b^2]_0^b 1/EJ$$

$$= (1/12 b) 1/EJ = 1/12 b/EJ$$

$$L_{FG}^{x_0} = \int_0^b (5/8 x^2/b^2 - 1/4 x^3/b^3) Fb 1/EJ dx + \int_0^b (1/2 x/b) \theta dx$$

$$= [5/24 x^3/b^2 - 1/16 x^4/b^3]_0^b Fb 1/EJ + [1/4 x^2/b]_0^b \theta$$

$$= (5/24 b - 1/16 b) Fb 1/EJ + (1/4 b) \theta = 19/48 Fb^2/EJ$$

$$L_{GF}^{x_0} = \int_0^b (3/8 - 1/2 x/b - 1/8 x^2/b^2 + 1/4 x^3/b^3) Fb 1/EJ dx + \int_0^b (-1/2 + 1/2 x/b) \theta dx$$

$$= [3/8 x - 1/4 x^2/b - 1/24 x^3/b^2 + 1/16 x^4/b^3]_0^b Fb 1/EJ + [-1/2 x + 1/4 x^2/b]_0^b \theta$$

$$= (3/8 b - 1/4 b - 1/24 b + 1/16 b) Fb 1/EJ + (-1/2 b + 1/4 b) \theta = 19/48 Fb^2/EJ$$

$$L_{GD}^{x_0} = \int_0^b (1/2 x/b - 1/2 x^3/b^3) Fb 1/EJ dx = [1/4 x^2/b - 1/8 x^4/b^3]_0^b Fb 1/EJ$$

$$= (1/4 b - 1/8 b) Fb 1/EJ = 1/8 Fb^2/EJ$$

$$L_{DG}^{x_0} = \int_0^b (x/b - 3/2 x^2/b^2 + 1/2 x^3/b^3) Fb 1/EJ dx = [1/2 x^2/b - 1/2 x^3/b^2 + 1/8 x^4/b^3]_0^b Fb 1/EJ$$

$$= (1/2 b - 1/2 b + 1/8 b) Fb 1/EJ = 1/8 Fb^2/EJ$$

$$L_{GA}^{x_0} = \int_0^b (-3/8 + 3/4 x/b - 3/8 x^2/b^2) Fb 1/EJ dx = [-3/8 x + 3/8 x^2/b - 1/8 x^3/b^2]_0^b Fb 1/EJ$$

$$= (-3/8 b + 3/8 b - 1/8 b) Fb 1/EJ = -1/8 Fb^2/EJ$$

$$L_{AG}^{x_0} = \int_0^b (-3/8 x^2/b^2) Fb 1/EJ dx = [-1/8 x^3/b^2]_0^b Fb 1/EJ$$

$$= (-1/8 b) Fb 1/EJ = -1/8 Fb^2/EJ$$

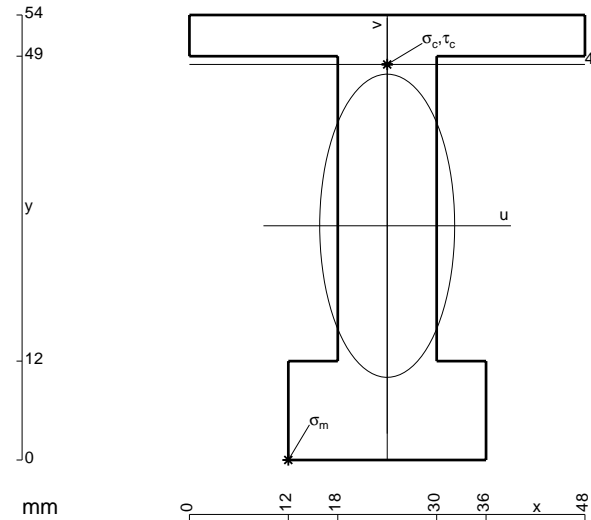

- A = 972. mm²
- J_u = 329140. mm⁴
- J_v = 65232. mm⁴
- y_g = 28.43 mm
- T_y = -4020. N
- M_x = -2653200. Nmm
- x_m = 12. mm
- u_m = -12. mm
- v_m = -28.43 mm
- σ_m = -Mv/J_u = -229.1 N/mm²
- x_c = 24. mm
- y_c = 48. mm
- v_c = 19.57 mm
- σ_c = -Mv/J_u = 157.8 N/mm²
- τ_c = 5.882 N/mm²
- σ_q = √σ²+3τ² = 158.1 N/mm²
- S = 5779. mm³

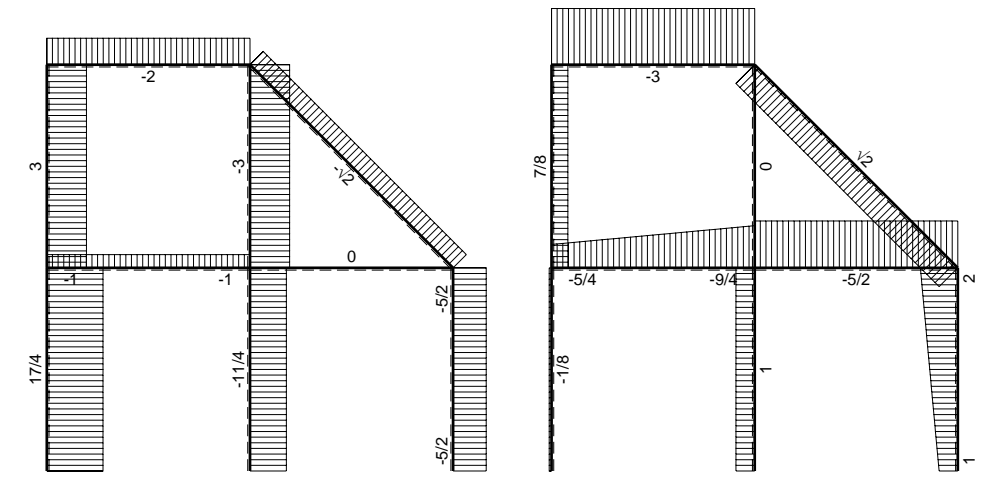
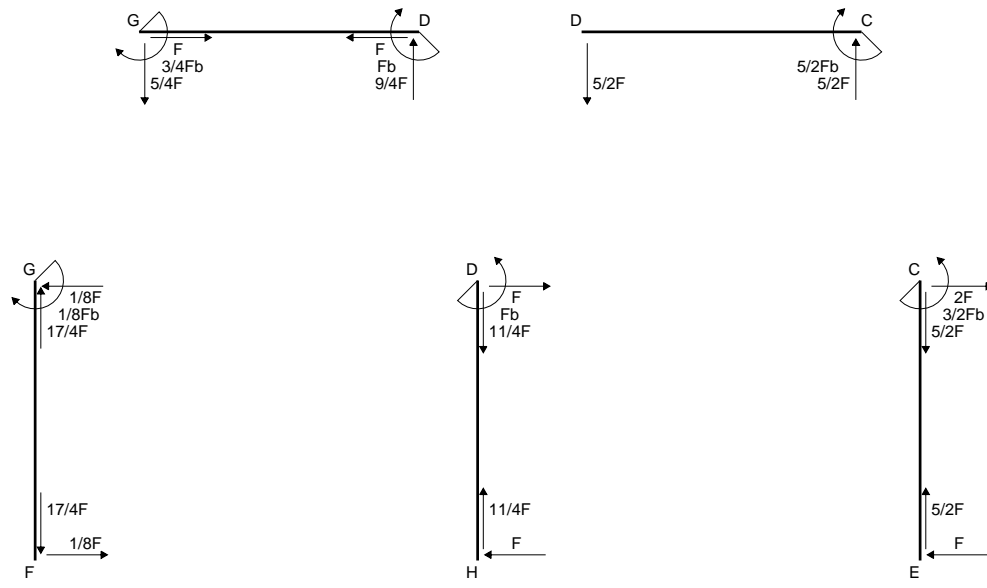
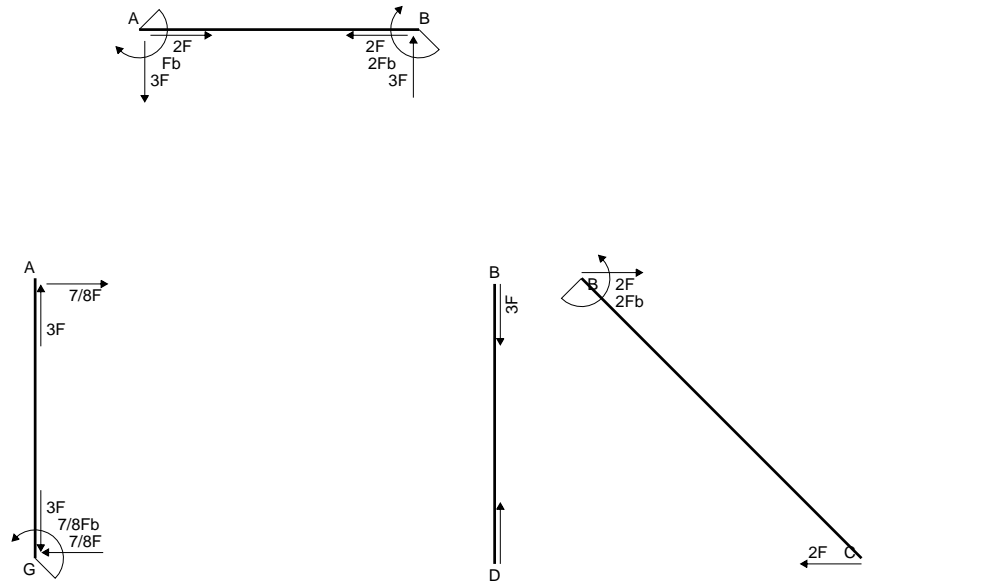

← ⊕ → F

↑ ⊕ ↓ F

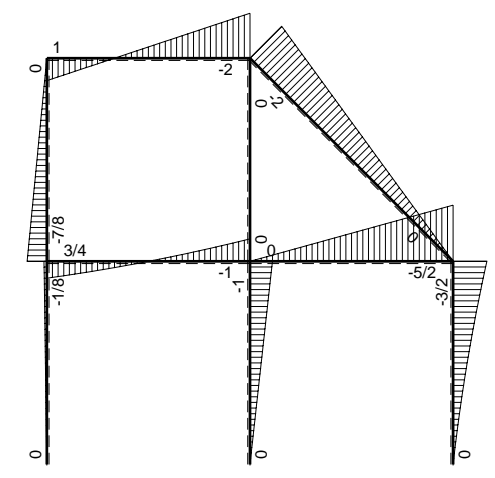

⊕ ⊖ F_b

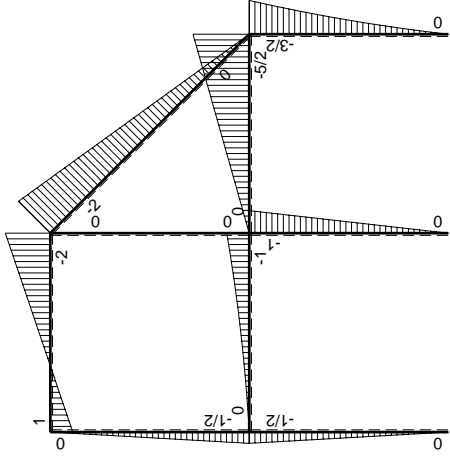
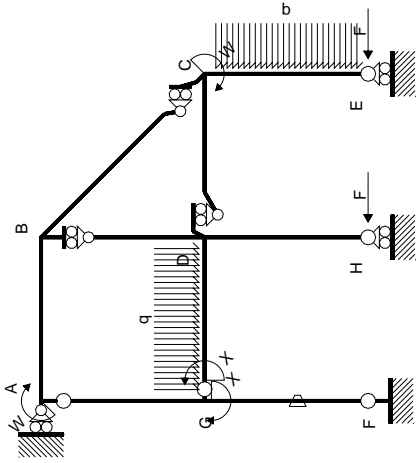

Schema di calcolo iperstatico

M_0 flessione da carichi assegnati

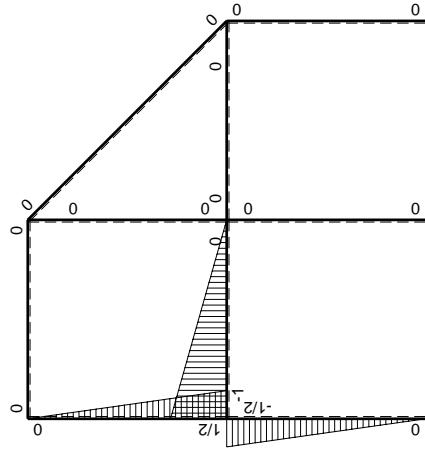

M_1 flessione da iperstatica $X=1$

Quadro contributi PLV per iperstatica $X=W_{GD}$

→	$M_x(x)$	$M_o(x)$	θ	$M_x M_o$	$M_x \theta$	$M_x M_x$	$\int M_x(M_o/EJ+\theta)dx$	$\int X M_x M_x/EJ dx$	
AB b	0	Fb-3Fx	0	0	0	0	0+0	0	
BA b	0	2Fb-3Fx	0	0	0	0	0	0	
BC $\sqrt{2}b$	0	-2Fb+ $\sqrt{2}Fx$	0	0	0	0	0	0	
BD b	0	0	0	0	0	0	0+0	0	
DB b	0	0	0	0	0	0	0	0	
DC b	0	-5/2Fx	0	0	0	0	0+0	0	
CD b	0	5/2Fb-5/2Fx	0	0	0	0	0	0	
CE b	0	-3/2Fb+2Fx-1/2qx ²	0	0	0	0	0+0	0	
EC b	0	Fx+1/2qx ²	0	0	0	0	0	0	
FG b	-1/2x/b	-1/2Fx	-Fb/EJ	1/4Fx ² /b	1/2Fx/EJ	1/4x ² /b ²	(1/12+1/4)Fb ² /EJ	1/12Xb/EJ	
GF b	1/2-1/2x/b	1/2Fb-1/2Fx	Fb/EJ	1/4Fb-1/2Fx+1/4Fx ² /b	1/2Fb/EJ-1/2Fx/EJ	1/4-1/2x/b+1/4x ² /b ²			
GD b	-1+x/b	-1/2Fx-1/2qx ²	0	1/2Fx-1/2qx ³ /b	0	1-2x/b+x ² /b ²	(1/8+0)Fb ² /EJ	1/3Xb/EJ	
DG b	x/b	Fb-3/2Fx+1/2qx ²	0	Fx-3/2Fx ² /b+1/2qx ³ /b	0	x ² /b ²			
DH b	0	-Fb+Fx	0	0	0	0	0+0	0	
HD b	0	Fx	0	0	0	0	0	0	
GA b	1/2-1/2x/b	-1/2Fb+1/2Fx	0	-1/4Fb+1/2Fx-1/4Fx ² /b	0	1/4-1/2x/b+1/4x ² /b ²	(-1/12+0)Fb ² /EJ	1/12Xb/EJ	
AG b	-1/2x/b	1/2Fx	0	-1/4Fx ² /b	0	1/4x ² /b ²			
	totali							3/8Fb ² /EJ	1/2Xb/EJ
	iperstatica $X=W_{GD}$							-3/4Fb	

Sviluppi di calcolo iperstatica

$$L_{FG}^{xx} = \int_0^b (1/4 x^2/b^2) 1/EJ dx = [1/12 x^3/b^2]_0^b 1/EJ$$

$$= (1/12 b) 1/EJ = 1/12 b/EJ$$

$$L_{GF}^{xx} = \int_0^b (1/4 - 1/2 x/b + 1/4 x^2/b^2) 1/EJ dx = [1/4 x - 1/4 x^2/b + 1/12 x^3/b^2]_0^b 1/EJ$$

$$= (1/4 b - 1/4 b + 1/12 b) 1/EJ = 1/12 b/EJ$$

$$L_{GD}^{xx} = \int_0^b (1 - 2 x/b + x^2/b^2) 1/EJ dx = [x - x^2/b + 1/3 x^3/b^2]_0^b 1/EJ$$

$$= (b - b + 1/3 b) 1/EJ = 1/3 b/EJ$$

$$L_{DG}^{xx} = \int_0^b (x^2/b^2) 1/EJ dx = [1/3 x^3/b^2]_0^b 1/EJ$$

$$= (1/3 b) 1/EJ = 1/3 b/EJ$$

$$L_{GA}^{xx} = \int_0^b (1/4 - 1/2 x/b + 1/4 x^2/b^2) 1/EJ dx = [1/4 x - 1/4 x^2/b + 1/12 x^3/b^2]_0^b 1/EJ$$

$$= (1/4 b - 1/4 b + 1/12 b) 1/EJ = 1/12 b/EJ$$

$$L_{AG}^{xx} = \int_0^b (1/4 x^2/b^2) 1/EJ dx = [1/12 x^3/b^2]_0^b 1/EJ$$

$$= (1/12 b) 1/EJ = 1/12 b/EJ$$

$$L_{FG}^{xo} = \int_0^b (1/4 x^2/b^2) Fb 1/EJ dx + \int_0^b (1/2 x/b) \theta dx = [1/12 x^3/b^2]_0^b Fb 1/EJ + [1/4 x^2/b]_0^b \theta$$

$$= (1/12 b) Fb 1/EJ + (1/4 b) \theta = 1/3 Fb^2/EJ$$

$$L_{GF}^{xo} = \int_0^b (1/4 - 1/2 x/b + 1/4 x^2/b^2) Fb 1/EJ dx + \int_0^b (-1/2 + 1/2 x/b) \theta dx$$

$$= [1/4 x - 1/4 x^2/b + 1/12 x^3/b^2]_0^b Fb 1/EJ + [-1/2 x + 1/4 x^2/b]_0^b \theta$$

$$= (1/4 b - 1/4 b + 1/12 b) Fb 1/EJ + (-1/2 b + 1/4 b) \theta = 1/3 Fb^2/EJ$$

$$L_{GD}^{xo} = \int_0^b (1/2 x/b - 1/2 x^3/b^3) Fb 1/EJ dx = [1/4 x^2/b - 1/8 x^4/b^3]_0^b Fb 1/EJ$$

$$= (1/4 b - 1/8 b) Fb 1/EJ = 1/8 Fb^2/EJ$$

$$L_{DG}^{xo} = \int_0^b (x/b - 3/2 x^2/b^2 + 1/2 x^3/b^3) Fb 1/EJ dx = [1/2 x^2/b - 1/2 x^3/b^2 + 1/8 x^4/b^3]_0^b Fb 1/EJ$$

$$= (1/2 b - 1/2 b + 1/8 b) Fb 1/EJ = 1/8 Fb^2/EJ$$

$$L_{GA}^{xo} = \int_0^b (-1/4 + 1/2 x/b - 1/4 x^2/b^2) Fb 1/EJ dx = [-1/4 x + 1/4 x^2/b - 1/12 x^3/b^2]_0^b Fb 1/EJ$$

$$= (-1/4 b + 1/4 b - 1/12 b) Fb 1/EJ = -1/12 Fb^2/EJ$$

$$L_{AG}^{xo} = \int_0^b (-1/4 x^2/b^2) Fb 1/EJ dx = [-1/12 x^3/b^2]_0^b Fb 1/EJ$$

$$= (-1/12 b) Fb 1/EJ = -1/12 Fb^2/EJ$$

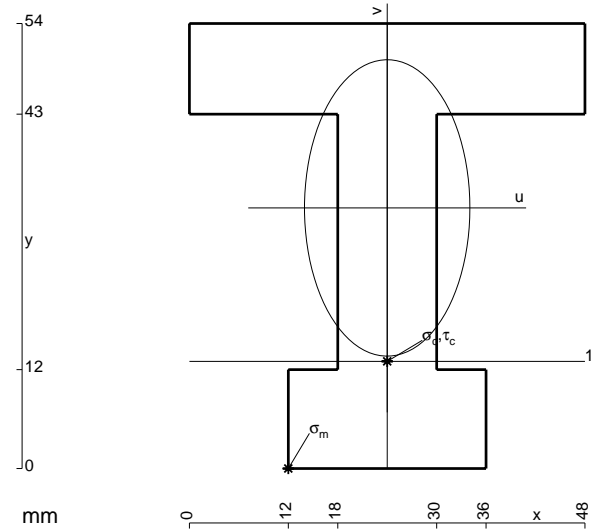

- A = 1188. mm²
- J_u = 384370. mm⁴
- J_v = 119664. mm⁴
- y_g = 31.62 mm
- T_y = -4100. N
- M_x = -2911000. Nmm
- x_m = 12. mm
- u_m = -12. mm
- v_m = -31.62 mm
- σ_m = -Mv/J_u = -239.5 N/mm²
- x_c = 24. mm
- y_c = 13. mm
- v_c = -18.62 mm
- σ_c = -Mv/J_u = -141. N/mm²
- τ_c = 6.763 N/mm²
- σ_o = √σ²+3τ² = 141.5 N/mm²
- S = 7608. mm³

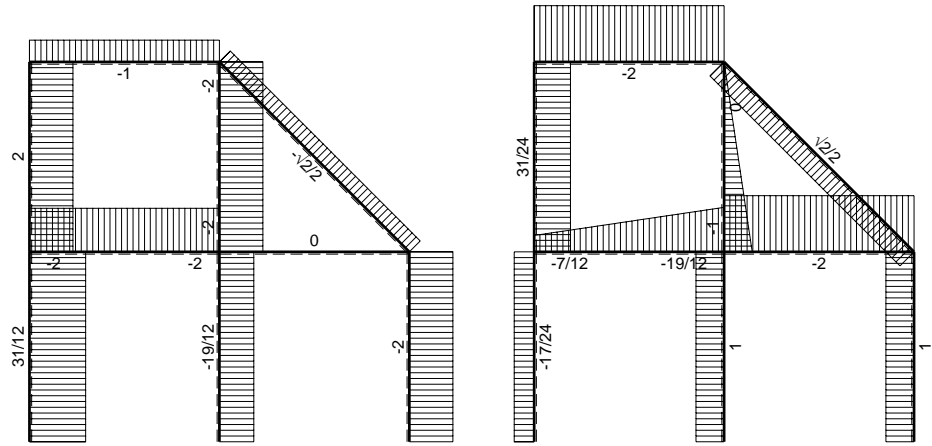
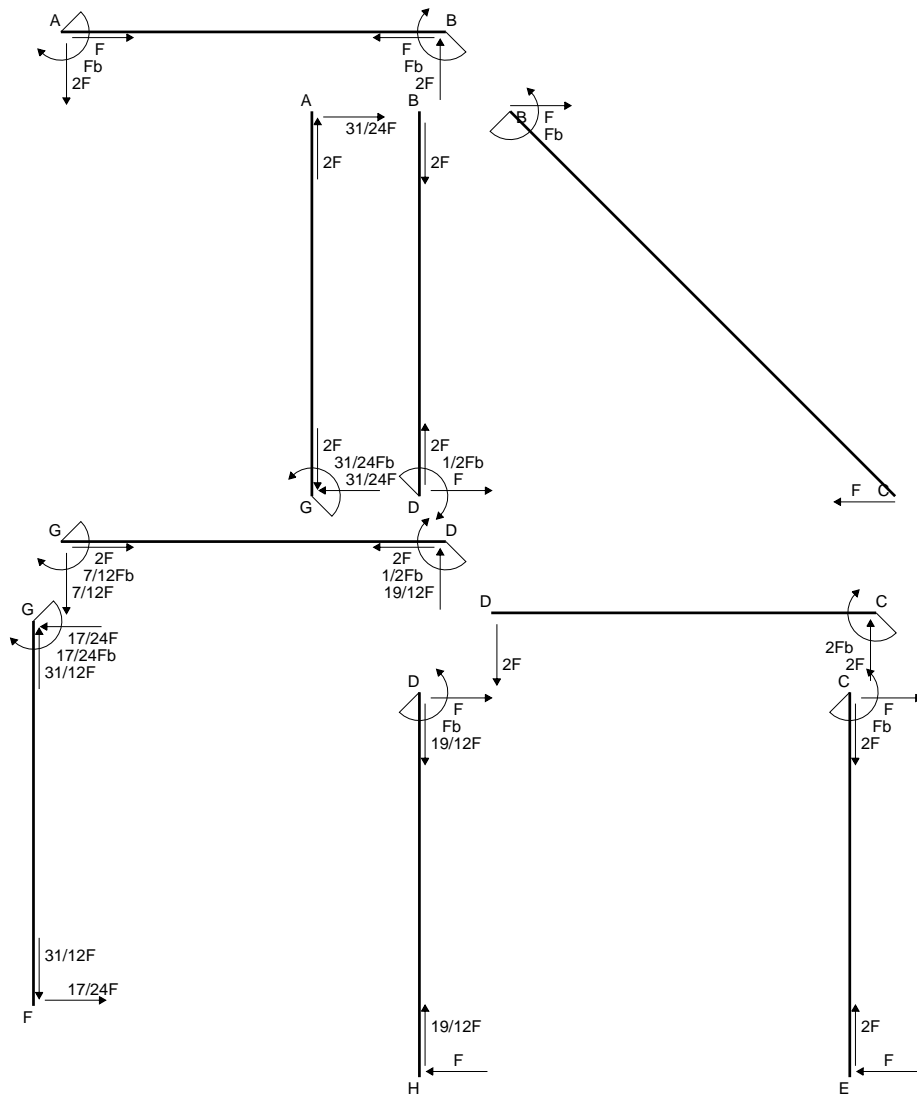

← ⊕ → F

↑ ⊕ ↓ F

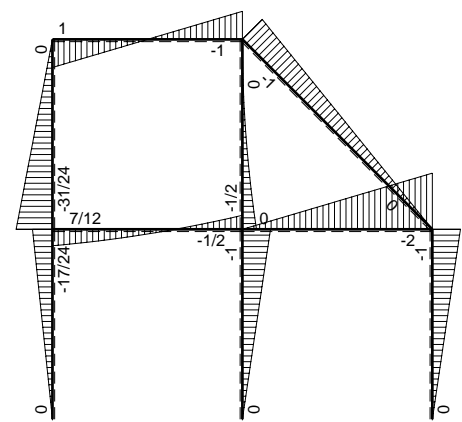

⊕ Fb

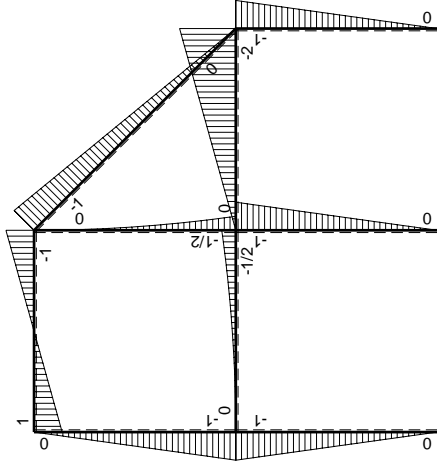
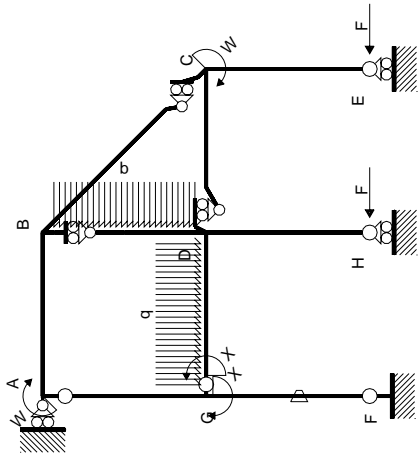

Schema di calcolo iperstatico

M_0 , flessione da carichi assegnati

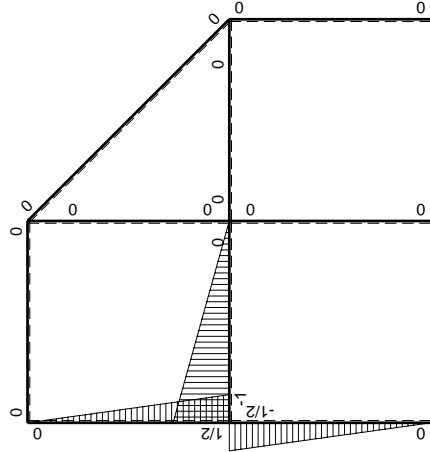

M_x , flessione da iperstatica $X=1$

Quadro contributi PLV per iperstatica $X=W_{GD}$

→	$M_x(x)$	$M_o(x)$	θ	$M_x M_o$	$M_x \theta$	$M_x M_x$	$\int M_x(M_o/EJ+\theta)dx$	$\int X M_x M_x/EJdx$
AB b	0	Fb-2Fx	0	0	0	0	0+0	0
BA b	0	Fb-2Fx	0	0	0	0	0	0
BC $\sqrt{2}b$	0	-Fb+ $\sqrt{2}/2Fx$	0	0	0	0	0	0
BD b	0	-1/2qx ²	0	0	0	0	0+0	0
DB b	0	1/2Fb-Fx+1/2qx ²	0	0	0	0	0	0
DC b	0	-2Fx	0	0	0	0	0+0	0
CD b	0	2Fb-2Fx	0	0	0	0	0	0
CE b	0	-Fb+Fx	0	0	0	0	0+0	0
EC b	0	Fx	0	0	0	0	0	0
FG b	-1/2x/b	-Fx	-Fb/EJ	1/2Fx ² /b	1/2Fx/EJ	1/4x ² /b ²	(1/6+1/4)Fb ² /EJ	1/12Xb/EJ
GF b	1/2-1/2x/b	Fb-Fx	Fb/EJ	1/2Fb-Fx+1/2Fx ² /b	1/2Fb/EJ-1/2Fx/EJ	1/4-1/2x/b+1/4x ² /b ²		
GD b	-1+x/b	-1/2qx ²	0	1/2Fx ² /b-1/2qx ³ /b	0	1-2x/b+x ² /b ²	(1/24+0)Fb ² /EJ	1/3Xb/EJ
DG b	x/b	1/2Fb-Fx+1/2qx ²	0	1/2Fx-Fx ² /b+1/2qx ³ /b	0	x ² /b ²		
DH b	0	-Fb+Fx	0	0	0	0	0+0	0
HD b	0	Fx	0	0	0	0	0	0
GA b	1/2-1/2x/b	-Fb+Fx	0	-1/2Fb+Fx-1/2Fx ² /b	0	1/4-1/2x/b+1/4x ² /b ²	(-1/6+0)Fb ² /EJ	1/12Xb/EJ
AG b	-1/2x/b	Fx	0	-1/2Fx ² /b	0	1/4x ² /b ²		
	totali						7/24Fb ² /EJ	1/2Xb/EJ
	iperstatica $X=W_{GD}$						-7/12Fb	

Sviluppi di calcolo iperstatica

$$L_{FG}^{xx} = \int_0^b (1/4 x^2/b^2) 1/EJ dx = [1/12 x^3/b^2]_0^b 1/EJ$$

$$= (1/12 b) 1/EJ = 1/12 b/EJ$$

$$L_{GF}^{xx} = \int_0^b (1/4 - 1/2 x/b + 1/4 x^2/b^2) 1/EJ dx = [1/4 x - 1/4 x^2/b + 1/12 x^3/b^2]_0^b 1/EJ$$

$$= (1/4 b - 1/4 b + 1/12 b) 1/EJ = 1/12 b/EJ$$

$$L_{GD}^{xx} = \int_0^b (1 - 2 x/b + x^2/b^2) 1/EJ dx = [x - x^2/b + 1/3 x^3/b^2]_0^b 1/EJ$$

$$= (b - b + 1/3 b) 1/EJ = 1/3 b/EJ$$

$$L_{DG}^{xx} = \int_0^b (x^2/b^2) 1/EJ dx = [1/3 x^3/b^2]_0^b 1/EJ$$

$$= (1/3 b) 1/EJ = 1/3 b/EJ$$

$$L_{GA}^{xx} = \int_0^b (1/4 - 1/2 x/b + 1/4 x^2/b^2) 1/EJ dx = [1/4 x - 1/4 x^2/b + 1/12 x^3/b^2]_0^b 1/EJ$$

$$= (1/4 b - 1/4 b + 1/12 b) 1/EJ = 1/12 b/EJ$$

$$L_{AG}^{xx} = \int_0^b (1/4 x^2/b^2) 1/EJ dx = [1/12 x^3/b^2]_0^b 1/EJ$$

$$= (1/12 b) 1/EJ = 1/12 b/EJ$$

$$L_{FG}^{xo} = \int_0^b (1/2 x^2/b^2) Fb 1/EJ dx + \int_0^b (1/2 x/b) \theta dx = [1/6 x^3/b^2]_0^b Fb 1/EJ + [1/4 x^2/b]_0^b \theta$$

$$= (1/6 b) Fb 1/EJ + (1/4 b) \theta = 5/12 Fb^2/EJ$$

$$L_{GF}^{xo} = \int_0^b (1/2 - x/b + 1/2 x^2/b^2) Fb 1/EJ dx + \int_0^b (-1/2 + 1/2 x/b) \theta dx$$

$$= [1/2 x - 1/2 x^2/b + 1/6 x^3/b^2]_0^b Fb 1/EJ + [-1/2 x + 1/4 x^2/b]_0^b \theta$$

$$= (1/2 b - 1/2 b + 1/6 b) Fb 1/EJ + (-1/2 b + 1/4 b) \theta = 5/12 Fb^2/EJ$$

$$L_{GD}^{xo} = \int_0^b (1/2 x^2/b^2 - 1/2 x^3/b^3) Fb 1/EJ dx = [1/6 x^3/b^2 - 1/8 x^4/b^3]_0^b Fb 1/EJ$$

$$= (1/6 b - 1/8 b) Fb 1/EJ = 1/24 Fb^2/EJ$$

$$L_{DG}^{xo} = \int_0^b (1/2 x/b - x^2/b^2 + 1/2 x^3/b^3) Fb 1/EJ dx = [1/4 x^2/b - 1/3 x^3/b^2 + 1/8 x^4/b^3]_0^b Fb 1/EJ$$

$$= (1/4 b - 1/3 b + 1/8 b) Fb 1/EJ = 1/24 Fb^2/EJ$$

$$L_{GA}^{xo} = \int_0^b (-1/2 + x/b - 1/2 x^2/b^2) Fb 1/EJ dx = [-1/2 x + 1/2 x^2/b - 1/6 x^3/b^2]_0^b Fb 1/EJ$$

$$= (-1/2 b + 1/2 b - 1/6 b) Fb 1/EJ = -1/6 Fb^2/EJ$$

$$L_{AG}^{xo} = \int_0^b (-1/2 x^2/b^2) Fb 1/EJ dx = [-1/6 x^3/b^2]_0^b Fb 1/EJ$$

$$= (-1/6 b) Fb 1/EJ = -1/6 Fb^2/EJ$$

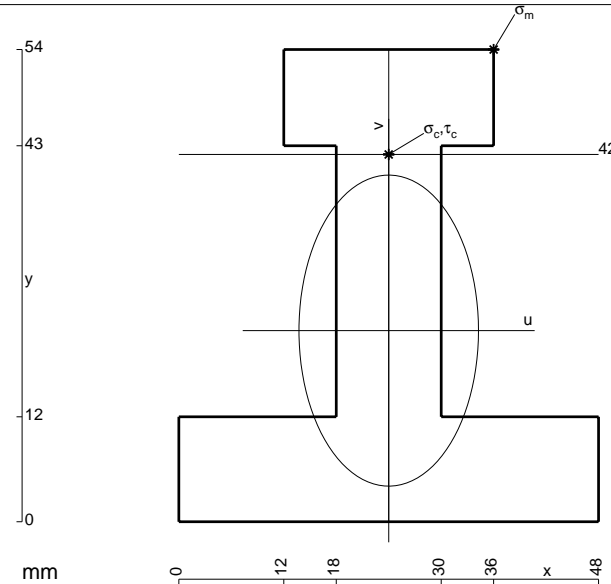

- A = 1212. mm²
- J_u = 383443. mm⁴
- J_v = 127728. mm⁴
- y_g = 21.86 mm
- T_y = -3120. N
- M_x = -2371200. Nmm
- x_m = 36. mm
- y_m = 54. mm
- u_m = 12. mm
- v_m = 32.14 mm
- σ_m = -Mv/J_u = 198.8 N/mm²
- x_c = 24. mm
- y_c = 42. mm
- v_c = 20.14 mm
- σ_c = -Mv/J_u = 124.6 N/mm²
- τ_c = 4.937 N/mm²
- σ_q = √σ²+3τ² = 124.9 N/mm²
- S = 7282. mm³

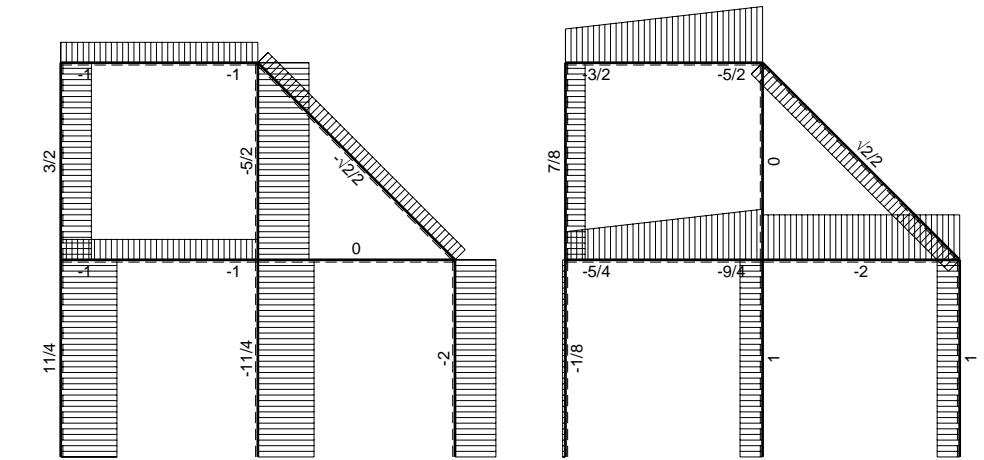
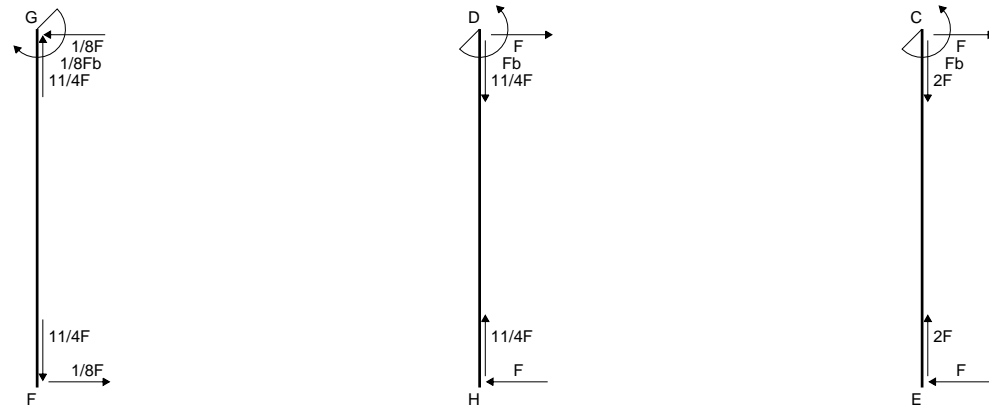
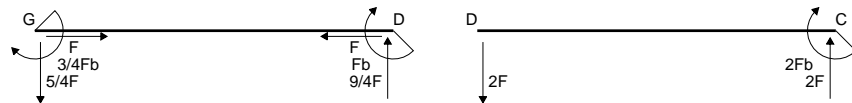
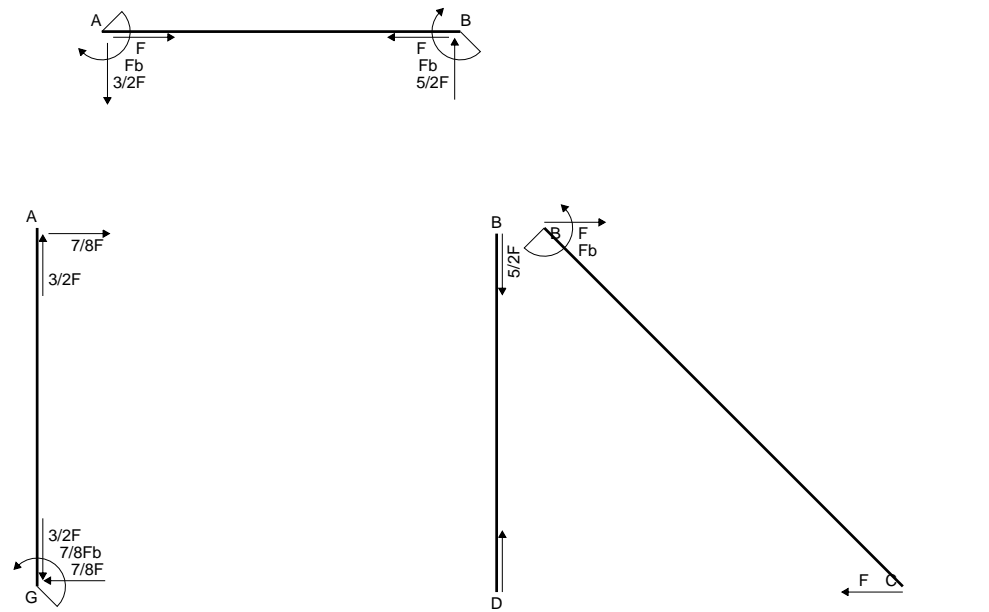

← ⊕ → F

↑ ⊕ ↓ F

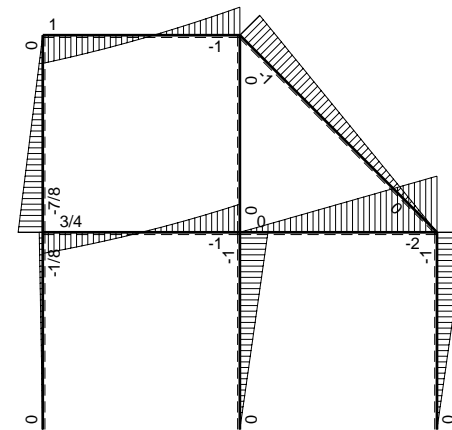

⊕ ⊖ Fb

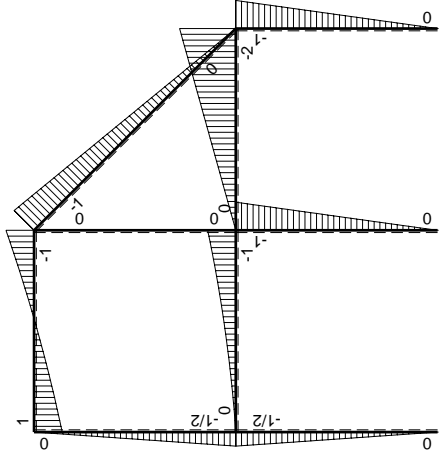
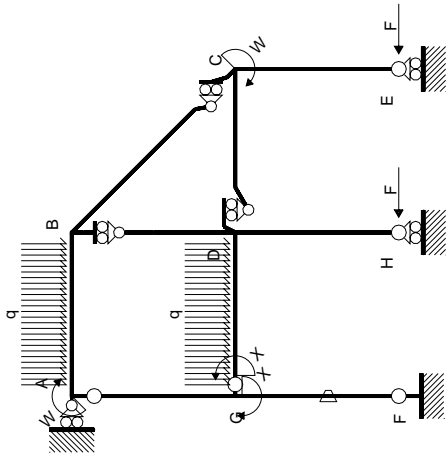

Schema di calcolo iperstatico

M_0 flessione da carichi assegnati

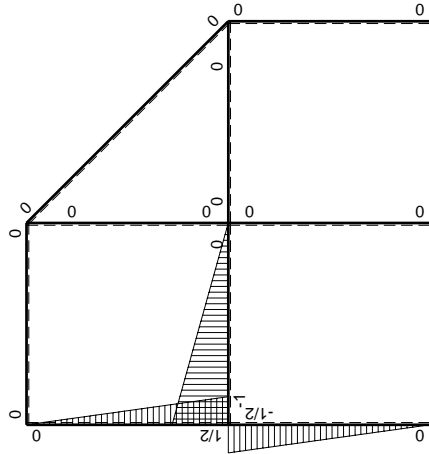

M_x flessione da iperstatica $X=1$

Quadro contributi PLV per iperstatica $X=W_{GD}$

→	$M_x(x)$	$M_o(x)$	θ	$M_x M_o$	$M_x \theta$	$M_x M_x$	$\int M_x(M_o/EJ+\theta)dx$	$\int X M_x M_x/EJ dx$
AB b	0	$Fb-3/2Fx-1/2qx^2$	0	0	0	0	0+0	0
BA b	0	$Fb-5/2Fx+1/2qx^2$	0	0	0	0	0	0
BC $\sqrt{2}b$	0	$-Fb+\sqrt{2}/2Fx$	0	0	0	0	0	0
BD b	0	0	0	0	0	0	0+0	0
DB b	0	0	0	0	0	0	0	0
DC b	0	$-2Fx$	0	0	0	0	0+0	0
CD b	0	$2Fb-2Fx$	0	0	0	0	0	0
CE b	0	$-Fb+Fx$	0	0	0	0	0+0	0
EC b	0	Fx	0	0	0	0	0	0
FG b	$-1/2x/b$	$-1/2Fx$	$-Fb/EJ$	$1/4Fx^2/b$	$1/2Fx/EJ$	$1/4x^2/b^2$	$(1/12+1/4)Fb^2/EJ$	$1/12Xb/EJ$
GF b	$1/2-1/2x/b$	$1/2Fb-1/2Fx$	Fb/EJ	$1/4Fb-1/2Fx+1/4Fx^2/b$	$1/2Fb/EJ-1/2Fx/EJ$	$1/4-1/2x/b+1/4x^2/b^2$		
GD b	$-1+x/b$	$-1/2Fx-1/2qx^2$	0	$1/2Fx-1/2qx^3/b$	0	$1-2x/b+x^2/b^2$	$(1/8+0)Fb^2/EJ$	$1/3Xb/EJ$
DG b	x/b	$Fb-3/2Fx+1/2qx^2$	0	$Fx-3/2Fx^2/b+1/2qx^3/b$	0	x^2/b^2		
DH b	0	$-Fb+Fx$	0	0	0	0	0+0	0
HD b	0	Fx	0	0	0	0	0	0
GA b	$1/2-1/2x/b$	$-1/2Fb+1/2Fx$	0	$-1/4Fb+1/2Fx-1/4Fx^2/b$	0	$1/4-1/2x/b+1/4x^2/b^2$	$(-1/12+0)Fb^2/EJ$	$1/12Xb/EJ$
AG b	$-1/2x/b$	$1/2Fx$	0	$-1/4Fx^2/b$	0	$1/4x^2/b^2$		
	totali						$3/8Fb^2/EJ$	$1/2Xb/EJ$
	iperstatica $X=W_{GD}$						$-3/4Fb$	

Sviluppi di calcolo iperstatica

$$L_{FG}^{xx} = \int_0^b (1/4 x^2/b^2) 1/EJ dx = [1/12 x^3/b^2]_0^b 1/EJ$$

$$= (1/12 b) 1/EJ = 1/12 b/EJ$$

$$L_{GF}^{xx} = \int_0^b (1/4 - 1/2 x/b + 1/4 x^2/b^2) 1/EJ dx = [1/4 x - 1/4 x^2/b + 1/12 x^3/b^2]_0^b 1/EJ$$

$$= (1/4 b - 1/4 b + 1/12 b) 1/EJ = 1/12 b/EJ$$

$$L_{GD}^{xx} = \int_0^b (1 - 2 x/b + x^2/b^2) 1/EJ dx = [x - x^2/b + 1/3 x^3/b^2]_0^b 1/EJ$$

$$= (b - b + 1/3 b) 1/EJ = 1/3 b/EJ$$

$$L_{DG}^{xx} = \int_0^b (x^2/b^2) 1/EJ dx = [1/3 x^3/b^2]_0^b 1/EJ$$

$$= (1/3 b) 1/EJ = 1/3 b/EJ$$

$$L_{GA}^{xx} = \int_0^b (1/4 - 1/2 x/b + 1/4 x^2/b^2) 1/EJ dx = [1/4 x - 1/4 x^2/b + 1/12 x^3/b^2]_0^b 1/EJ$$

$$= (1/4 b - 1/4 b + 1/12 b) 1/EJ = 1/12 b/EJ$$

$$L_{AG}^{xx} = \int_0^b (1/4 x^2/b^2) 1/EJ dx = [1/12 x^3/b^2]_0^b 1/EJ$$

$$= (1/12 b) 1/EJ = 1/12 b/EJ$$

$$L_{FG}^{xo} = \int_0^b (1/4 x^2/b^2) Fb 1/EJ dx + \int_0^b (1/2 x/b) \theta dx = [1/12 x^3/b^2]_0^b Fb 1/EJ + [1/4 x^2/b]_0^b \theta$$

$$= (1/12 b) Fb 1/EJ + (1/4 b) \theta = 1/3 Fb^2/EJ$$

$$L_{GF}^{xo} = \int_0^b (1/4 - 1/2 x/b + 1/4 x^2/b^2) Fb 1/EJ dx + \int_0^b (-1/2 + 1/2 x/b) \theta dx$$

$$= [1/4 x - 1/4 x^2/b + 1/12 x^3/b^2]_0^b Fb 1/EJ + [-1/2 x + 1/4 x^2/b]_0^b \theta$$

$$= (1/4 b - 1/4 b + 1/12 b) Fb 1/EJ + (-1/2 b + 1/4 b) \theta = 1/3 Fb^2/EJ$$

$$L_{GD}^{xo} = \int_0^b (1/2 x/b - 1/2 x^3/b^3) Fb 1/EJ dx = [1/4 x^2/b - 1/8 x^4/b^3]_0^b Fb 1/EJ$$

$$= (1/4 b - 1/8 b) Fb 1/EJ = 1/8 Fb^2/EJ$$

$$L_{DG}^{xo} = \int_0^b (x/b - 3/2 x^2/b^2 + 1/2 x^3/b^3) Fb 1/EJ dx = [1/2 x^2/b - 1/2 x^3/b^2 + 1/8 x^4/b^3]_0^b Fb 1/EJ$$

$$= (1/2 b - 1/2 b + 1/8 b) Fb 1/EJ = 1/8 Fb^2/EJ$$

$$L_{GA}^{xo} = \int_0^b (-1/4 + 1/2 x/b - 1/4 x^2/b^2) Fb 1/EJ dx = [-1/4 x + 1/4 x^2/b - 1/12 x^3/b^2]_0^b Fb 1/EJ$$

$$= (-1/4 b + 1/4 b - 1/12 b) Fb 1/EJ = -1/12 Fb^2/EJ$$

$$L_{AG}^{xo} = \int_0^b (-1/4 x^2/b^2) Fb 1/EJ dx = [-1/12 x^3/b^2]_0^b Fb 1/EJ$$

$$= (-1/12 b) Fb 1/EJ = -1/12 Fb^2/EJ$$

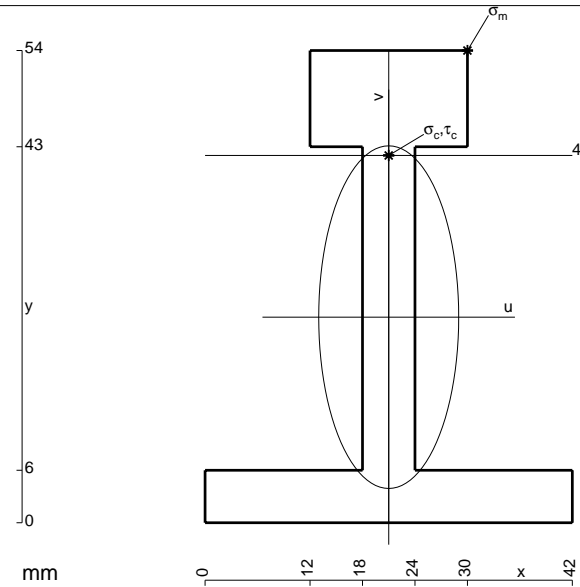

- A = 672. mm²
- J_u = 257954. mm⁴
- J_v = 43056. mm⁴
- y_g = 23.51 mm
- T_y = -2180. N
- M_x = -1765800. Nmm
- x_m = 30. mm
- y_m = 54. mm
- u_m = 9. mm
- v_m = 30.49 mm
- σ_m = -Mv/J_u = 208.7 N/mm²
- x_c = 21. mm
- y_c = 42. mm
- v_c = 18.49 mm
- σ_c = -Mv/J_u = 126.6 N/mm²
- τ_c = 7.13 N/mm²
- σ_q = √σ²+3τ² = 127.2 N/mm²
- S = 5062. mm³

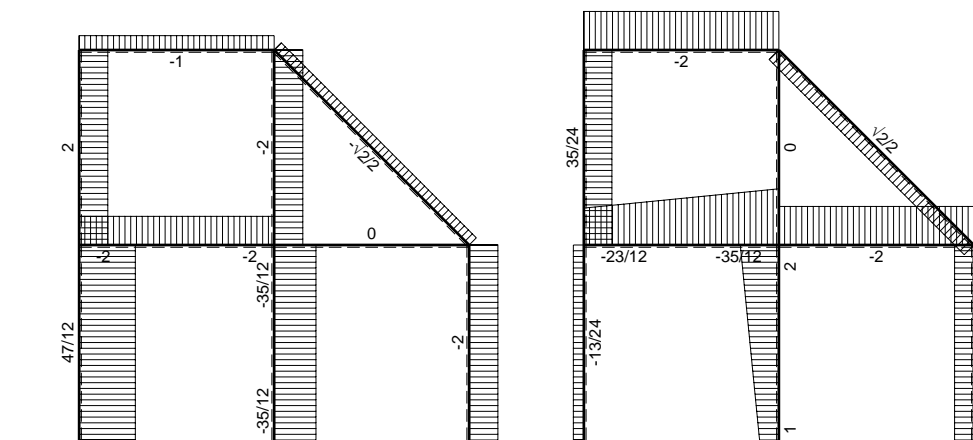
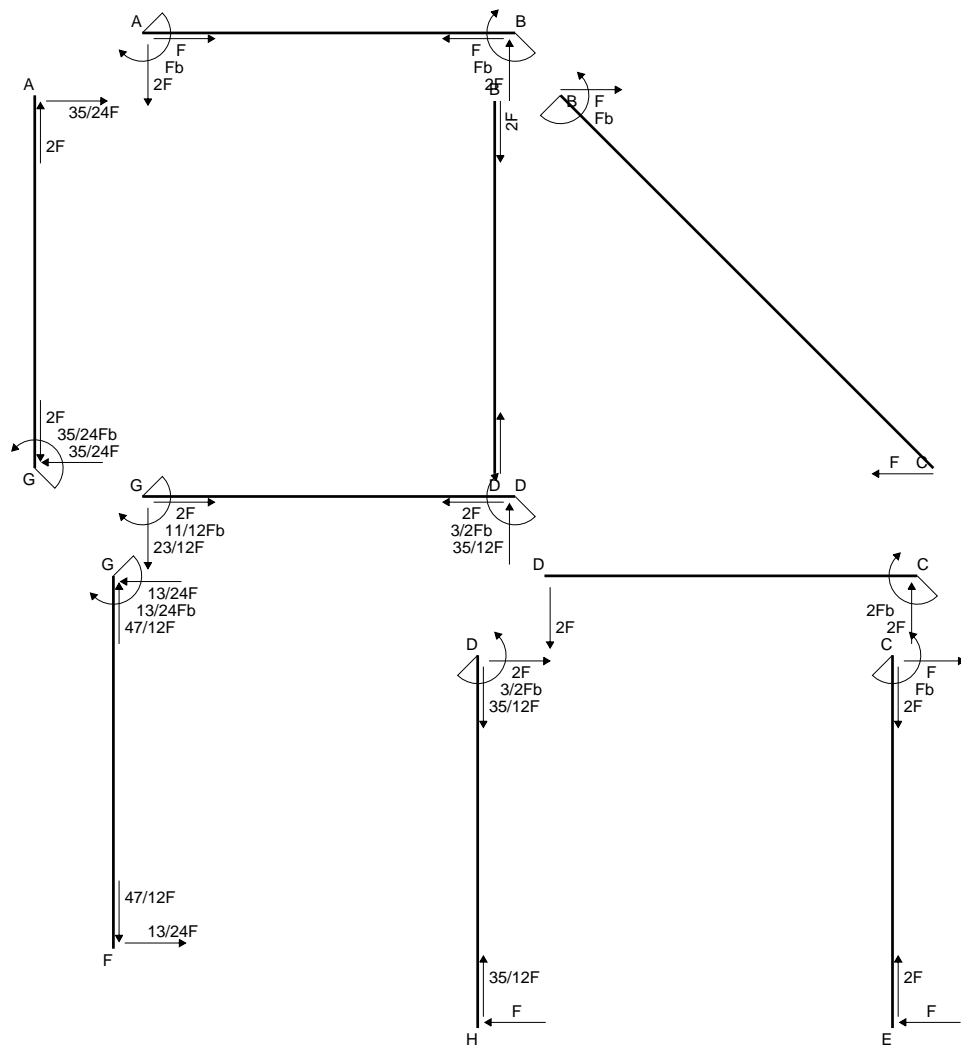

← ⊕ → F

↑ ⊕ ↓ F

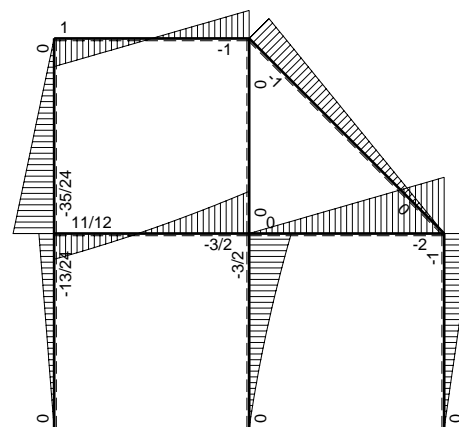

⊕ ⊖ F_b

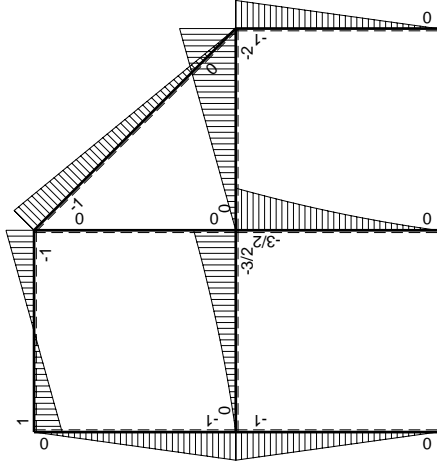
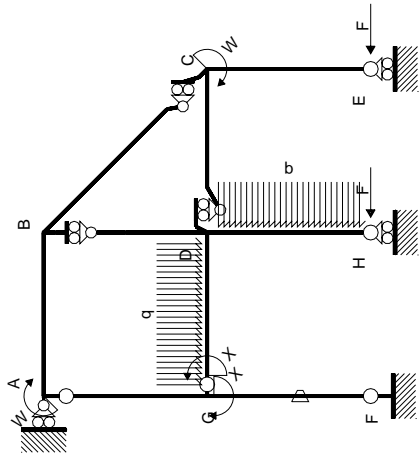

Schema di calcolo iperstatico

M_0 flessione da carichi assegnati

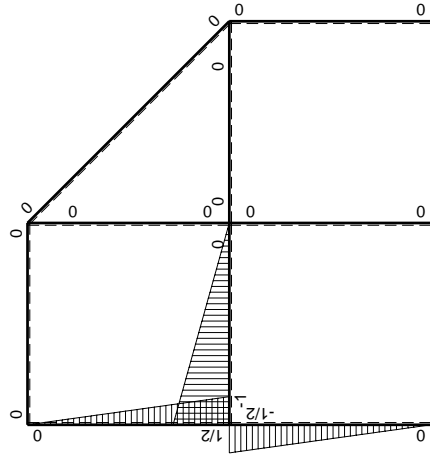

M_x flessione da iperstatica $X=1$

Quadro contributi PLV per iperstatica $X=W_{GD}$

→	$M_x(x)$	$M_o(x)$	θ	$M_x M_o$	$M_x \theta$	$M_x M_x$	$\int M_x(M_o/EJ+\theta)dx$	$\int X M_x M_x/EJdx$
AB b	0	Fb-2Fx	0	0	0	0	0+0	0
BA b	0	Fb-2Fx	0	0	0	0	0	0
BC $\sqrt{2}b$	0	-Fb+ $\sqrt{2}/2Fx$	0	0	0	0	0	0
BD b	0	0	0	0	0	0	0+0	0
DB b	0	0	0	0	0	0	0	0
DC b	0	-2Fx	0	0	0	0	0+0	0
CD b	0	2Fb-2Fx	0	0	0	0	0	0
CE b	0	-Fb+Fx	0	0	0	0	0+0	0
EC b	0	Fx	0	0	0	0	0	0
FG b	-1/2x/b	-Fx	-Fb/EJ	1/2Fx ² /b	1/2Fx/EJ	1/4x ² /b ²	(1/6+1/4)Fb ² /EJ	1/12Xb/EJ
GF b	1/2-1/2x/b	Fb-Fx	Fb/EJ	1/2Fb-Fx+1/2Fx ² /b	1/2Fb/EJ-1/2Fx/EJ	1/4-1/2x/b+1/4x ² /b ²		
GD b	-1+x/b	-Fx-1/2qx ²	0	Fx-1/2Fx ² /b-1/2qx ³ /b	0	1-2x/b+x ² /b ²	(5/24+0)Fb ² /EJ	1/3Xb/EJ
DG b	x/b	3/2Fb-2Fx+1/2qx ²	0	3/2Fx-2Fx ² /b+1/2qx ³ /b	0	x ² /b ²		
DH b	0	-3/2Fb+2Fx-1/2qx ²	0	0	0	0	0+0	0
HD b	0	Fx+1/2qx ²	0	0	0	0		
GA b	1/2-1/2x/b	-Fb+Fx	0	-1/2Fb+Fx-1/2Fx ² /b	0	1/4-1/2x/b+1/4x ² /b ²	(-1/6+0)Fb ² /EJ	1/12Xb/EJ
AG b	-1/2x/b	Fx	0	-1/2Fx ² /b	0	1/4x ² /b ²		
	totali						11/24Fb ² /EJ	1/2Xb/EJ
	iperstatica $X=W_{GD}$						-11/12Fb	

Sviluppi di calcolo iperstatica

$$L_{FG}^{xx} = \int_0^b (1/4 x^2/b^2) 1/EJ dx = [1/12 x^3/b^2]_0^b 1/EJ$$

$$= (1/12 b) 1/EJ = 1/12 b/EJ$$

$$L_{GF}^{xx} = \int_0^b (1/4 - 1/2 x/b + 1/4 x^2/b^2) 1/EJ dx = [1/4 x - 1/4 x^2/b + 1/12 x^3/b^2]_0^b 1/EJ$$

$$= (1/4 b - 1/4 b + 1/12 b) 1/EJ = 1/12 b/EJ$$

$$L_{GD}^{xx} = \int_0^b (1 - 2 x/b + x^2/b^2) 1/EJ dx = [x - x^2/b + 1/3 x^3/b^2]_0^b 1/EJ$$

$$= (b - b + 1/3 b) 1/EJ = 1/3 b/EJ$$

$$L_{DG}^{xx} = \int_0^b (x^2/b^2) 1/EJ dx = [1/3 x^3/b^2]_0^b 1/EJ$$

$$= (1/3 b) 1/EJ = 1/3 b/EJ$$

$$L_{GA}^{xx} = \int_0^b (1/4 - 1/2 x/b + 1/4 x^2/b^2) 1/EJ dx = [1/4 x - 1/4 x^2/b + 1/12 x^3/b^2]_0^b 1/EJ$$

$$= (1/4 b - 1/4 b + 1/12 b) 1/EJ = 1/12 b/EJ$$

$$L_{AG}^{xx} = \int_0^b (1/4 x^2/b^2) 1/EJ dx = [1/12 x^3/b^2]_0^b 1/EJ$$

$$= (1/12 b) 1/EJ = 1/12 b/EJ$$

$$L_{FG}^{xo} = \int_0^b (1/2 x^2/b^2) Fb 1/EJ dx + \int_0^b (1/2 x/b) \theta dx = [1/6 x^3/b^2]_0^b Fb 1/EJ + [1/4 x^2/b]_0^b \theta$$

$$= (1/6 b) Fb 1/EJ + (1/4 b) \theta = 5/12 Fb^2/EJ$$

$$L_{GF}^{xo} = \int_0^b (1/2 - x/b + 1/2 x^2/b^2) Fb 1/EJ dx + \int_0^b (-1/2 + 1/2 x/b) \theta dx$$

$$= [1/2 x - 1/2 x^2/b + 1/6 x^3/b^2]_0^b Fb 1/EJ + [-1/2 x + 1/4 x^2/b]_0^b \theta$$

$$= (1/2 b - 1/2 b + 1/6 b) Fb 1/EJ + (-1/2 b + 1/4 b) \theta = 5/12 Fb^2/EJ$$

$$L_{GD}^{xo} = \int_0^b (x/b - 1/2 x^2/b^2 - 1/2 x^3/b^3) Fb 1/EJ dx = [1/2 x^2/b - 1/6 x^3/b^2 - 1/8 x^4/b^3]_0^b Fb 1/EJ$$

$$= (1/2 b - 1/6 b - 1/8 b) Fb 1/EJ = 5/24 Fb^2/EJ$$

$$L_{DG}^{xo} = \int_0^b (3/2 x/b - 2 x^2/b^2 + 1/2 x^3/b^3) Fb 1/EJ dx = [3/4 x^2/b - 2/3 x^3/b^2 + 1/8 x^4/b^3]_0^b Fb 1/EJ$$

$$= (3/4 b - 2/3 b + 1/8 b) Fb 1/EJ = 5/24 Fb^2/EJ$$

$$L_{GA}^{xo} = \int_0^b (-1/2 + x/b - 1/2 x^2/b^2) Fb 1/EJ dx = [-1/2 x + 1/2 x^2/b - 1/6 x^3/b^2]_0^b Fb 1/EJ$$

$$= (-1/2 b + 1/2 b - 1/6 b) Fb 1/EJ = -1/6 Fb^2/EJ$$

$$L_{AG}^{xo} = \int_0^b (-1/2 x^2/b^2) Fb 1/EJ dx = [-1/6 x^3/b^2]_0^b Fb 1/EJ$$

$$= (-1/6 b) Fb 1/EJ = -1/6 Fb^2/EJ$$

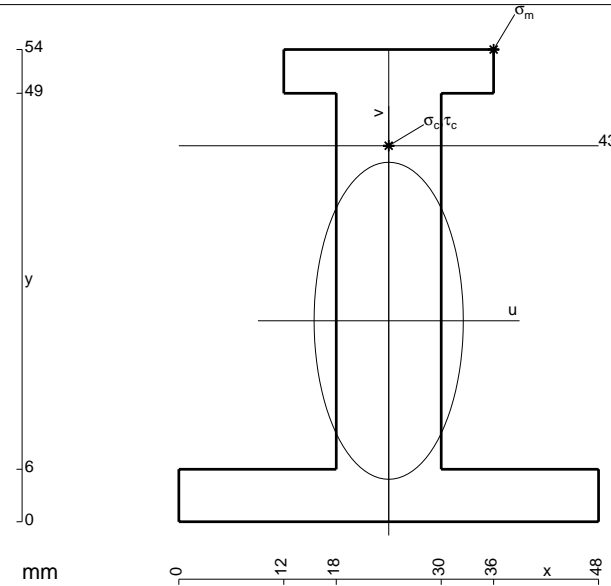

- A = 924. mm²
- J_u = 303740. mm⁴
- J_v = 67248. mm⁴
- y_g = 22.98 mm
- T_y = -2500. N
- M_x = -2150000. Nmm
- x_m = 36. mm
- y_m = 54. mm
- u_m = 12. mm
- v_m = 31.02 mm
- σ_m = -Mv/J_u = 219.6 N/mm²
- x_c = 24. mm
- y_c = 43. mm
- v_c = 20.02 mm
- σ_c = -Mv/J_u = 141.7 N/mm²
- τ_c = 3.484 N/mm²
- σ_q = √σ²+3τ² = 141.8 N/mm²
- S = 5080. mm³

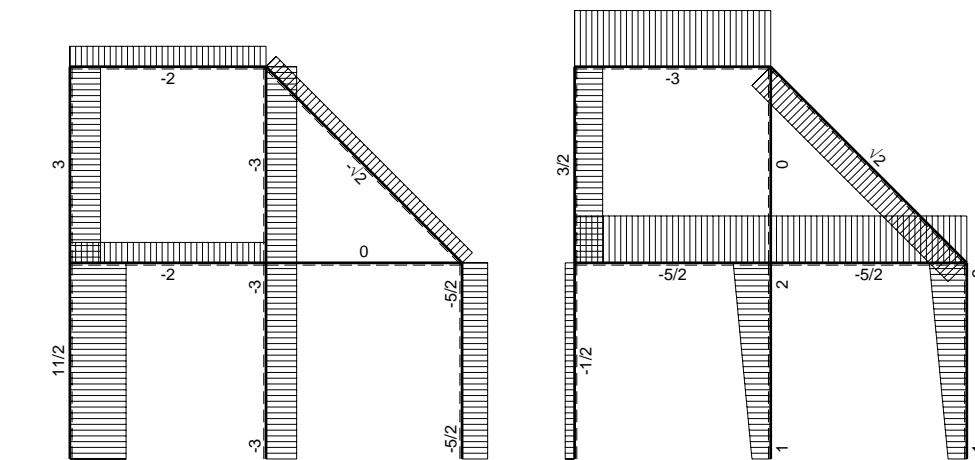
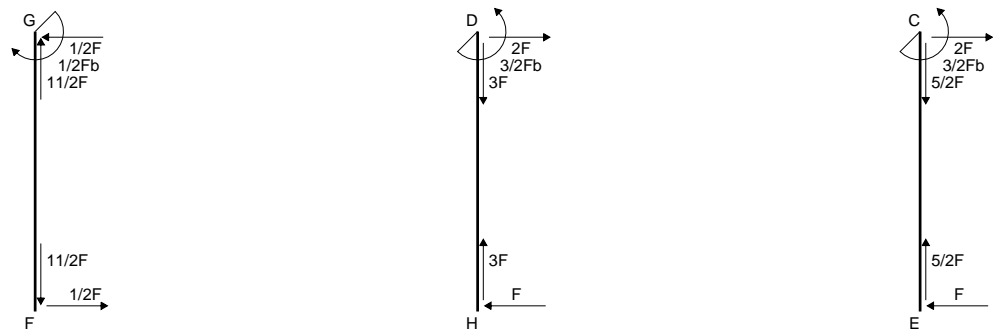
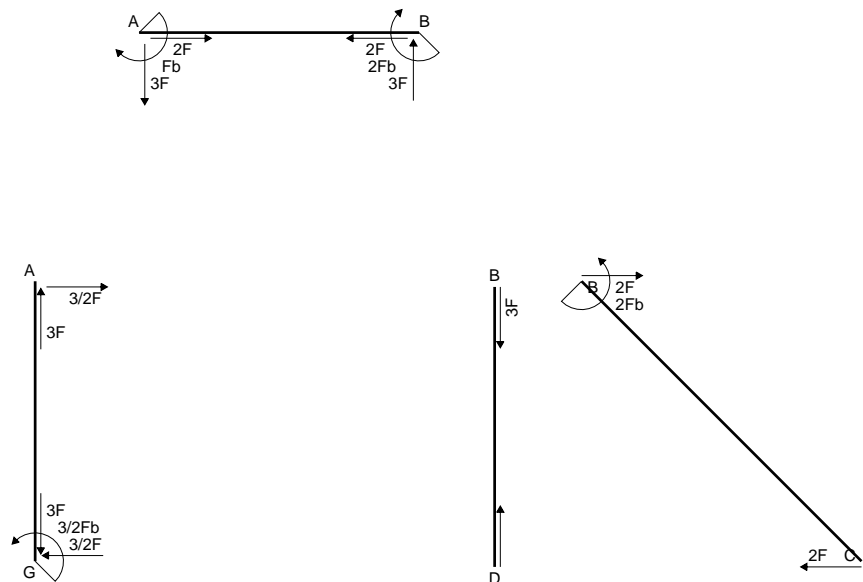

← ⊕ → F

↑ ⊕ ↓ F

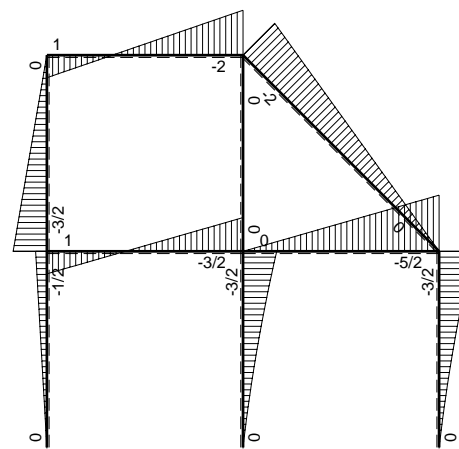

⊕ ⊖ F_b

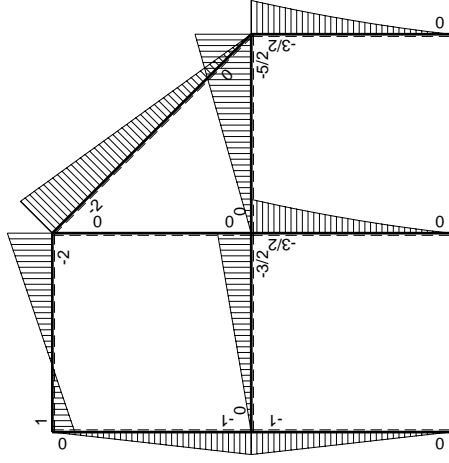
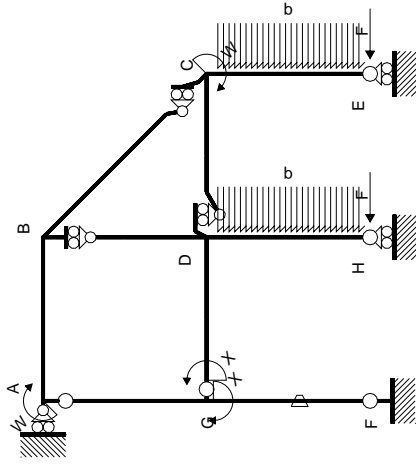

Schema di calcolo iperstatico

M_0 flessione da carichi assegnati

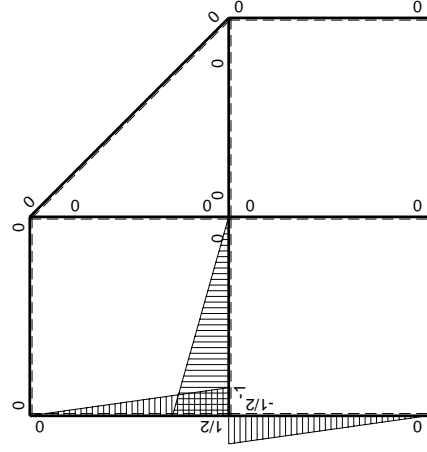

M_1 flessione da iperstatica $X=1$

Quadro contributi PLV per iperstatica $X=W_{GD}$

→	$M_x(x)$	$M_o(x)$	θ	$M_x M_o$	$M_x \theta$	$M_x M_x$	$\int M_x(M_o/EJ+\theta)dx$	$\int X M_x M_x/EJ dx$
AB b	0	$Fb-3Fx$	0	0	0	0	0+0	0
BA b	0	$2Fb-3Fx$	0	0	0	0	0	0
BC $\sqrt{2}b$	0	$-2Fb+\sqrt{2}Fx$	0	0	0	0	0	0
BD b	0	0	0	0	0	0	0+0	0
DB b	0	0	0	0	0	0	0	0
DC b	0	$-5/2Fx$	0	0	0	0	0+0	0
CD b	0	$5/2Fb-5/2Fx$	0	0	0	0	0	0
CE b	0	$-3/2Fb+2Fx-1/2qx^2$	0	0	0	0	0+0	0
EC b	0	$Fx+1/2qx^2$	0	0	0	0	0	0
FG b	$-1/2x/b$	$-Fx$	$-Fb/EJ$	$1/2Fx^2/b$	$1/2Fx/EJ$	$1/4x^2/b^2$	$(1/6+1/4)Fb^2/EJ$	$1/12Xb/EJ$
GF b	$1/2-1/2x/b$	$Fb-Fx$	Fb/EJ	$1/2Fb-Fx+1/2Fx^2/b$	$1/2Fb/EJ-1/2Fx/EJ$	$1/4-1/2x/b+1/4x^2/b^2$		
GD b	$-1+x/b$	$-3/2Fx$	0	$3/2Fx-3/2Fx^2/b$	0	$1-2x/b+x^2/b^2$	$(1/4+0)Fb^2/EJ$	$1/3Xb/EJ$
DG b	x/b	$3/2Fb-3/2Fx$	0	$3/2Fx-3/2Fx^2/b$	0	x^2/b^2		
DH b	0	$-3/2Fb+2Fx-1/2qx^2$	0	0	0	0	0+0	0
HD b	0	$Fx+1/2qx^2$	0	0	0	0	0	0
GA b	$1/2-1/2x/b$	$-Fb+Fx$	0	$-1/2Fb+Fx-1/2Fx^2/b$	0	$1/4-1/2x/b+1/4x^2/b^2$	$(-1/6+0)Fb^2/EJ$	$1/12Xb/EJ$
AG b	$-1/2x/b$	Fx	0	$-1/2Fx^2/b$	0	$1/4x^2/b^2$		
	totali						$1/2Fb^2/EJ$	$1/2Xb/EJ$
	iperstatica $X=W_{GD}$						$-Fb$	

Sviluppi di calcolo iperstatica

$$L_{FG}^{xx} = \int_0^b (1/4 x^2/b^2) 1/EJ dx = [1/12 x^3/b^2]_0^b 1/EJ$$

$$= (1/12 b) 1/EJ = 1/12 b/EJ$$

$$L_{GF}^{xx} = \int_0^b (1/4 - 1/2 x/b + 1/4 x^2/b^2) 1/EJ dx = [1/4 x - 1/4 x^2/b + 1/12 x^3/b^2]_0^b 1/EJ$$

$$= (1/4 b - 1/4 b + 1/12 b) 1/EJ = 1/12 b/EJ$$

$$L_{GD}^{xx} = \int_0^b (1 - 2 x/b + x^2/b^2) 1/EJ dx = [x - x^2/b + 1/3 x^3/b^2]_0^b 1/EJ$$

$$= (b - b + 1/3 b) 1/EJ = 1/3 b/EJ$$

$$L_{DG}^{xx} = \int_0^b (x^2/b^2) 1/EJ dx = [1/3 x^3/b^2]_0^b 1/EJ$$

$$= (1/3 b) 1/EJ = 1/3 b/EJ$$

$$L_{GA}^{xx} = \int_0^b (1/4 - 1/2 x/b + 1/4 x^2/b^2) 1/EJ dx = [1/4 x - 1/4 x^2/b + 1/12 x^3/b^2]_0^b 1/EJ$$

$$= (1/4 b - 1/4 b + 1/12 b) 1/EJ = 1/12 b/EJ$$

$$L_{AG}^{xx} = \int_0^b (1/4 x^2/b^2) 1/EJ dx = [1/12 x^3/b^2]_0^b 1/EJ$$

$$= (1/12 b) 1/EJ = 1/12 b/EJ$$

$$L_{FG}^{xo} = \int_0^b (1/2 x^2/b^2) Fb 1/EJ dx + \int_0^b (1/2 x/b) \theta dx = [1/6 x^3/b^2]_0^b Fb 1/EJ + [1/4 x^2/b]_0^b \theta$$

$$= (1/6 b) Fb 1/EJ + (1/4 b) \theta = 5/12 Fb^2/EJ$$

$$L_{GF}^{xo} = \int_0^b (1/2 - x/b + 1/2 x^2/b^2) Fb 1/EJ dx + \int_0^b (-1/2 + 1/2 x/b) \theta dx$$

$$= [1/2 x - 1/2 x^2/b + 1/6 x^3/b^2]_0^b Fb 1/EJ + [-1/2 x + 1/4 x^2/b]_0^b \theta$$

$$= (1/2 b - 1/2 b + 1/6 b) Fb 1/EJ + (-1/2 b + 1/4 b) \theta = 5/12 Fb^2/EJ$$

$$L_{GD}^{xo} = \int_0^b (3/2 x/b - 3/2 x^2/b^2) Fb 1/EJ dx = [3/4 x^2/b - 1/2 x^3/b^2]_0^b Fb 1/EJ$$

$$= (3/4 b - 1/2 b) Fb 1/EJ = 1/4 Fb^2/EJ$$

$$L_{DG}^{xo} = \int_0^b (3/2 x/b - 3/2 x^2/b^2) Fb 1/EJ dx = [3/4 x^2/b - 1/2 x^3/b^2]_0^b Fb 1/EJ$$

$$= (3/4 b - 1/2 b) Fb 1/EJ = 1/4 Fb^2/EJ$$

$$L_{GA}^{xo} = \int_0^b (-1/2 + x/b - 1/2 x^2/b^2) Fb 1/EJ dx = [-1/2 x + 1/2 x^2/b - 1/6 x^3/b^2]_0^b Fb 1/EJ$$

$$= (-1/2 b + 1/2 b - 1/6 b) Fb 1/EJ = -1/6 Fb^2/EJ$$

$$L_{AG}^{xo} = \int_0^b (-1/2 x^2/b^2) Fb 1/EJ dx = [-1/6 x^3/b^2]_0^b Fb 1/EJ$$

$$= (-1/6 b) Fb 1/EJ = -1/6 Fb^2/EJ$$

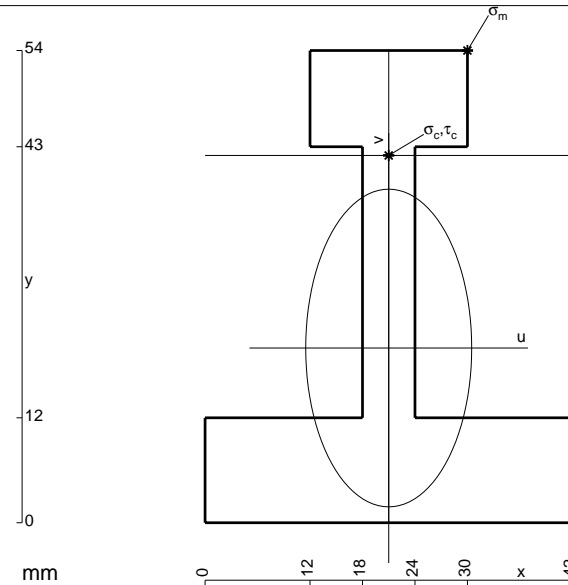

$$A = 888. \text{ mm}^2$$

$$J_u = 293012. \text{ mm}^4$$

$$J_v = 79992. \text{ mm}^4$$

$$y_g = 19.98 \text{ mm}$$

$$T_y = -2175. \text{ N}$$

$$M_x = -1979250. \text{ Nmm}$$

$$x_m = 30. \text{ mm}$$

$$y_m = 54. \text{ mm}$$

$$u_m = 9. \text{ mm}$$

$$v_m = 34.02 \text{ mm}$$

$$\sigma_m = -Mv/J_u = 229.8 \text{ N/mm}^2$$

$$x_c = 21. \text{ mm}$$

$$y_c = 42. \text{ mm}$$

$$v_c = 22.02 \text{ mm}$$

$$\sigma_c = -Mv/J_u = 148.7 \text{ N/mm}^2$$

$$\tau_c = 7.153 \text{ N/mm}^2$$

$$\sigma_\varphi = \sqrt{\sigma^2 + 3\tau^2} = 149.3 \text{ N/mm}^2$$

$$S = 5782. \text{ mm}^3$$

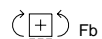
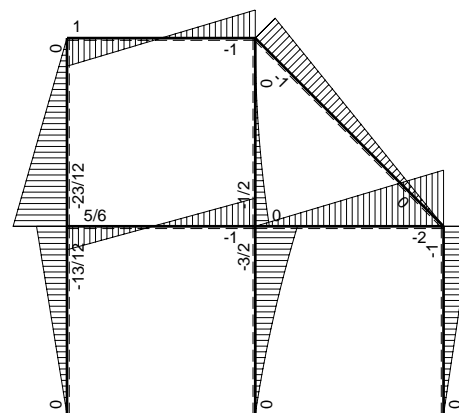
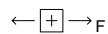
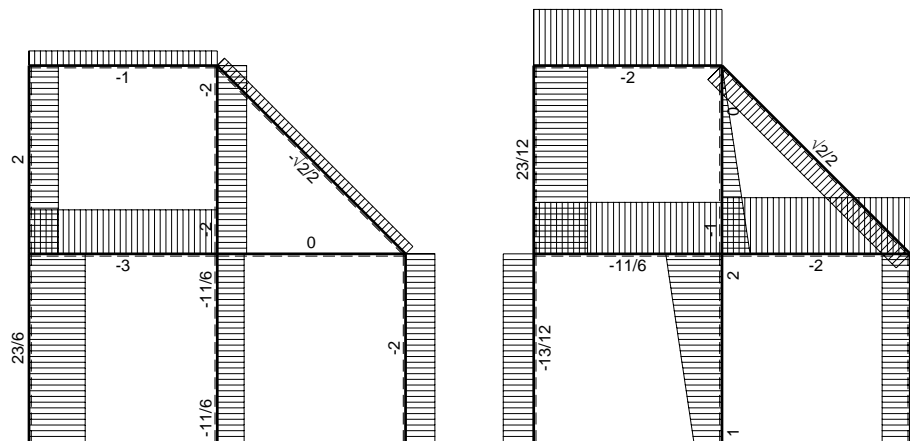
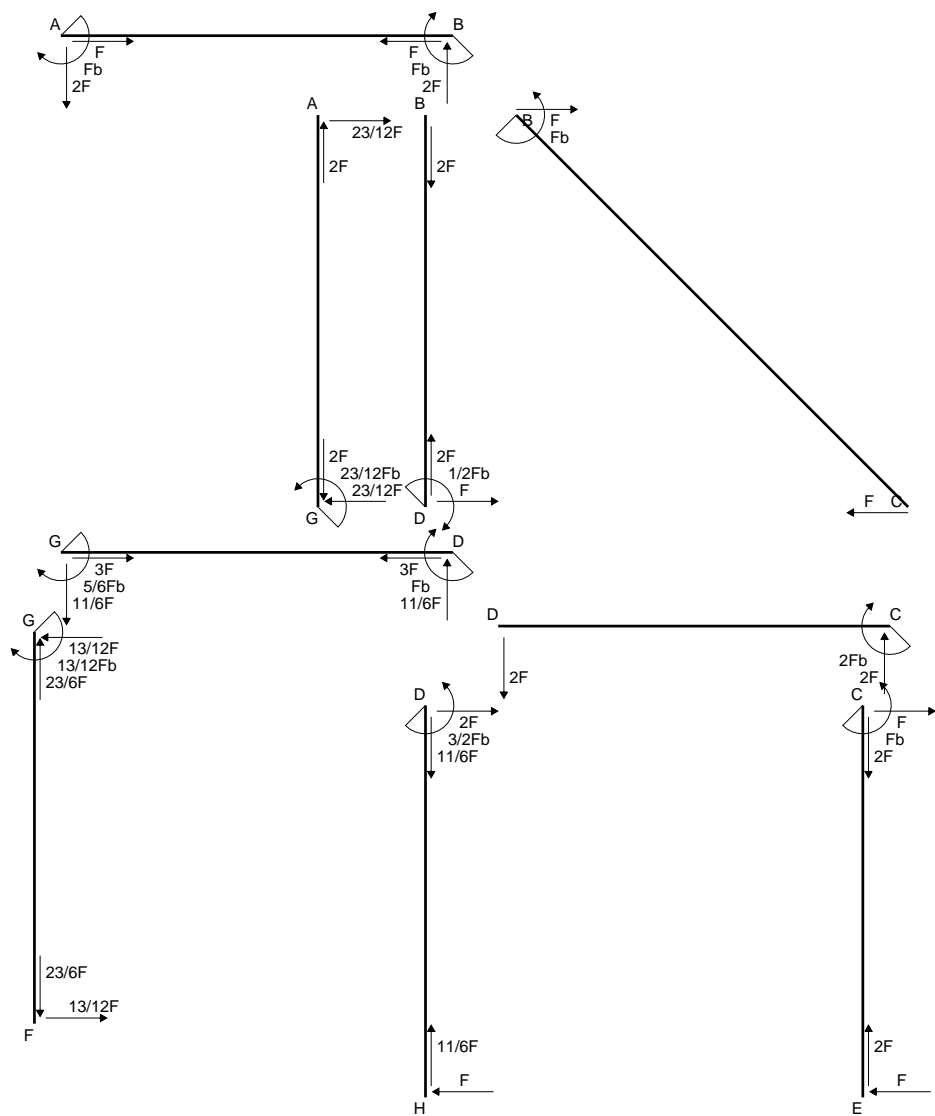

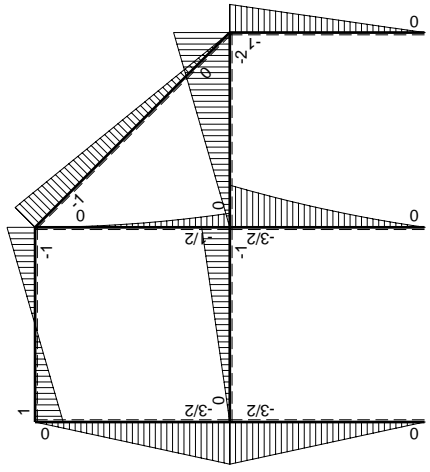
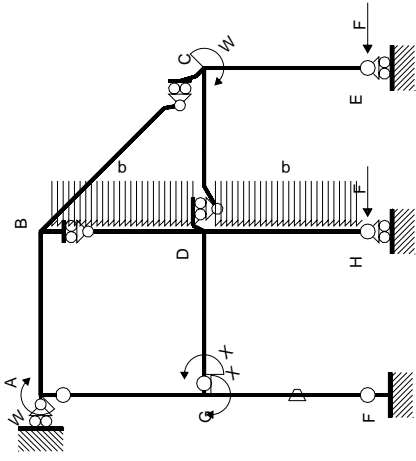

Schema di calcolo iperstatico

M_0 flessione da carichi assegnati

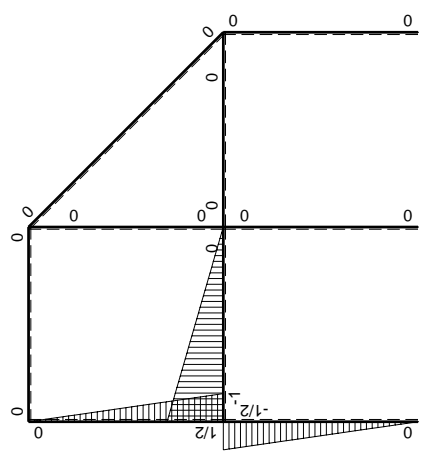

M_x flessione da iperstatica $X=1$

Quadro contributi PLV per iperstatica $X=W_{GD}$

→	$M_x(x)$	$M_o(x)$	θ	$M_x M_o$	$M_x \theta$	$M_x M_x$	$\int M_x(M_o/EJ+\theta)dx$	$\int X M_x M_x / EJ dx$
AB b	0	$Fb-2Fx$	0	0	0	0	0+0	0
BA b	0	$Fb-2Fx$	0	0	0	0	0	0
BC $\sqrt{2}b$	0	$-Fb+\sqrt{2}/2Fx$	0	0	0	0	0	0
BD b	0	$-1/2qx^2$	0	0	0	0	0+0	0
DB b	0	$1/2Fb-Fx+1/2qx^2$	0	0	0	0	0	0
DC b	0	$-2Fx$	0	0	0	0	0+0	0
CD b	0	$2Fb-2Fx$	0	0	0	0	0	0
CE b	0	$-Fb+Fx$	0	0	0	0	0+0	0
EC b	0	Fx	0	0	0	0	0	0
FG b	$-1/2x/b$	$-3/2Fx$	$-Fb/EJ$	$3/4Fx^2/b$	$1/2Fx/EJ$	$1/4x^2/b^2$	$(1/4+1/4)Fb^2/EJ$	$1/12Xb/EJ$
GF b	$1/2-1/2x/b$	$3/2Fb-3/2Fx$	Fb/EJ	$3/4Fb-3/2Fx+3/4Fx^2/b$	$1/2Fb/EJ-1/2Fx/EJ$	$1/4-1/2x/b+1/4x^2/b^2$		
GD b	$-1+x/b$	$-Fx$	0	$Fx-Fx^2/b$	0	$1-2x/b+x^2/b^2$	$(1/6+0)Fb^2/EJ$	$1/3Xb/EJ$
DG b	x/b	$Fb-Fx$	0	$Fx-Fx^2/b$	0	x^2/b^2		
DH b	0	$-3/2Fb+2Fx-1/2qx^2$	0	0	0	0	0+0	0
HD b	0	$Fx+1/2qx^2$	0	0	0	0		
GA b	$1/2-1/2x/b$	$-3/2Fb+3/2Fx$	0	$-3/4Fb+3/2Fx-3/4Fx^2/b$	0	$1/4-1/2x/b+1/4x^2/b^2$	$(-1/4+0)Fb^2/EJ$	$1/12Xb/EJ$
AG b	$-1/2x/b$	$3/2Fx$	0	$-3/4Fx^2/b$	0	$1/4x^2/b^2$		
	totali						$5/12Fb^2/EJ$	$1/2Xb/EJ$
	iperstatica $X=W_{GD}$						$-5/6Fb$	

Sviluppi di calcolo iperstatica

$$L_{FG}^{xx} = \int_0^b (1/4 x^2/b^2) 1/EJ dx = [1/12 x^3/b^2]_0^b 1/EJ$$

$$= (1/12 b) 1/EJ = 1/12 b/EJ$$

$$L_{GF}^{xx} = \int_0^b (1/4 - 1/2 x/b + 1/4 x^2/b^2) 1/EJ dx = [1/4 x - 1/4 x^2/b + 1/12 x^3/b^2]_0^b 1/EJ$$

$$= (1/4 b - 1/4 b + 1/12 b) 1/EJ = 1/12 b/EJ$$

$$L_{GD}^{xx} = \int_0^b (1 - 2 x/b + x^2/b^2) 1/EJ dx = [x - x^2/b + 1/3 x^3/b^2]_0^b 1/EJ$$

$$= (b - b + 1/3 b) 1/EJ = 1/3 b/EJ$$

$$L_{DG}^{xx} = \int_0^b (x^2/b^2) 1/EJ dx = [1/3 x^3/b^2]_0^b 1/EJ$$

$$= (1/3 b) 1/EJ = 1/3 b/EJ$$

$$L_{GA}^{xx} = \int_0^b (1/4 - 1/2 x/b + 1/4 x^2/b^2) 1/EJ dx = [1/4 x - 1/4 x^2/b + 1/12 x^3/b^2]_0^b 1/EJ$$

$$= (1/4 b - 1/4 b + 1/12 b) 1/EJ = 1/12 b/EJ$$

$$L_{AG}^{xx} = \int_0^b (1/4 x^2/b^2) 1/EJ dx = [1/12 x^3/b^2]_0^b 1/EJ$$

$$= (1/12 b) 1/EJ = 1/12 b/EJ$$

$$L_{FG}^{xo} = \int_0^b (3/4 x^2/b^2) Fb 1/EJ dx + \int_0^b (1/2 x/b) \theta dx = [1/4 x^3/b^2]_0^b Fb 1/EJ + [1/4 x^2/b]_0^b \theta$$

$$= (1/4 b) Fb 1/EJ + (1/4 b) \theta = 1/2 Fb^2/EJ$$

$$L_{GF}^{xo} = \int_0^b (3/4 - 3/2 x/b + 3/4 x^2/b^2) Fb 1/EJ dx + \int_0^b (-1/2 + 1/2 x/b) \theta dx$$

$$= [3/4 x - 3/4 x^2/b + 1/4 x^3/b^2]_0^b Fb 1/EJ + [-1/2 x + 1/4 x^2/b]_0^b \theta$$

$$= (3/4 b - 3/4 b + 1/4 b) Fb 1/EJ + (-1/2 b + 1/4 b) \theta = 1/2 Fb^2/EJ$$

$$L_{GD}^{xo} = \int_0^b (x/b - x^2/b^2) Fb 1/EJ dx = [1/2 x^2/b - 1/3 x^3/b^2]_0^b Fb 1/EJ$$

$$= (1/2 b - 1/3 b) Fb 1/EJ = 1/6 Fb^2/EJ$$

$$L_{DG}^{xo} = \int_0^b (x/b - x^2/b^2) Fb 1/EJ dx = [1/2 x^2/b - 1/3 x^3/b^2]_0^b Fb 1/EJ$$

$$= (1/2 b - 1/3 b) Fb 1/EJ = 1/6 Fb^2/EJ$$

$$L_{GA}^{xo} = \int_0^b (-3/4 + 3/2 x/b - 3/4 x^2/b^2) Fb 1/EJ dx = [-3/4 x + 3/4 x^2/b - 1/4 x^3/b^2]_0^b Fb 1/EJ$$

$$= (-3/4 b + 3/4 b - 1/4 b) Fb 1/EJ = -1/4 Fb^2/EJ$$

$$L_{AG}^{xo} = \int_0^b (-3/4 x^2/b^2) Fb 1/EJ dx = [-1/4 x^3/b^2]_0^b Fb 1/EJ$$

$$= (-1/4 b) Fb 1/EJ = -1/4 Fb^2/EJ$$

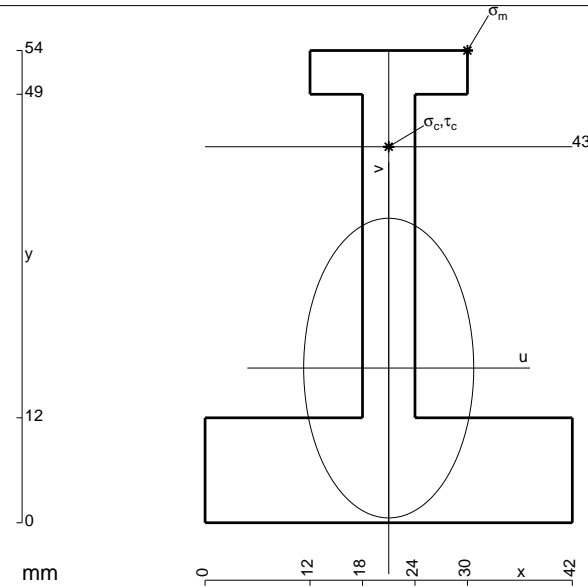

- A = 816. mm²
- J_u = 239746. mm⁴
- J_v = 77184. mm⁴
- y_g = 17.68 mm
- T_y = -1640. N
- M_x = -1574400. Nmm
- x_m = 30. mm
- y_m = 54. mm
- u_m = 9. mm
- v_m = 36.32 mm
- σ_m = -Mv/J_u = 238.5 N/mm²
- x_c = 21. mm
- y_c = 43. mm
- v_c = 25.32 mm
- σ_c = -Mv/J_u = 166.3 N/mm²
- τ_c = 4.632 N/mm²
- σ_q = √σ²+3τ² = 166.4 N/mm²
- S = 4063. mm³

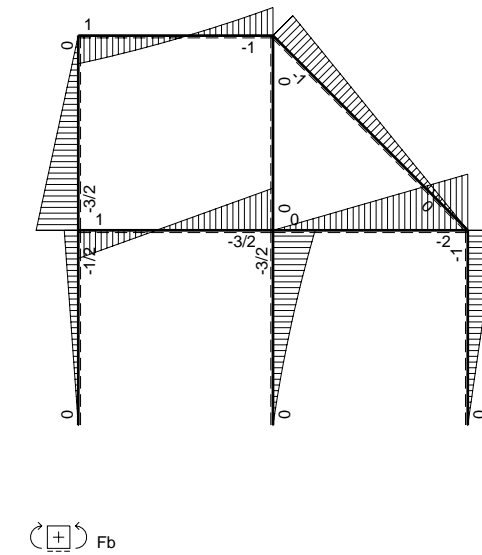
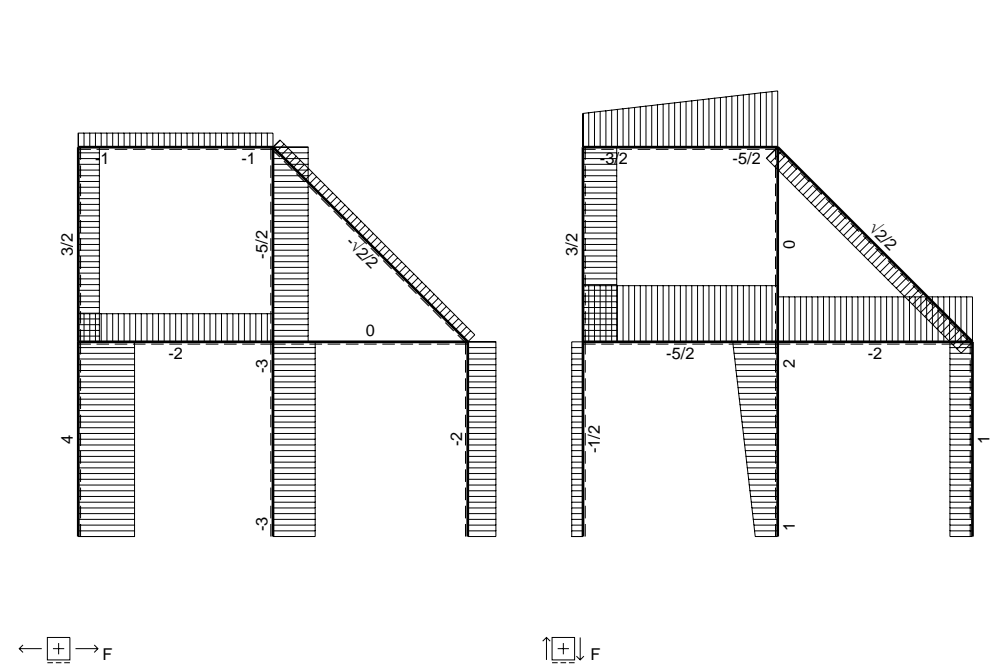
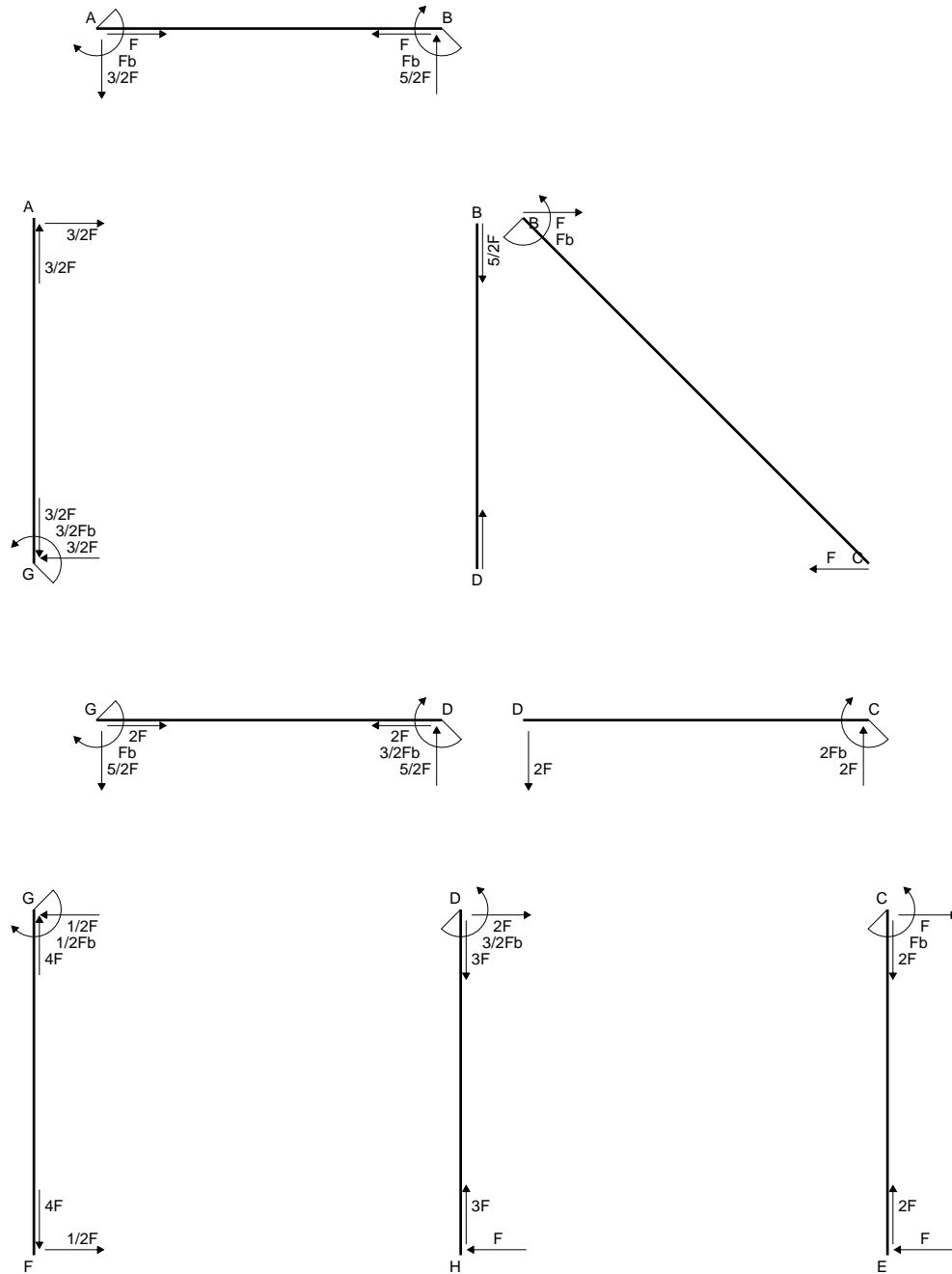

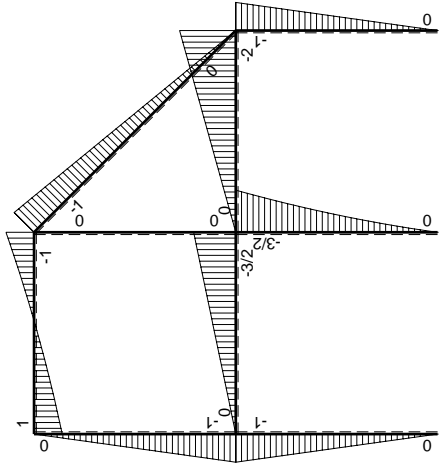
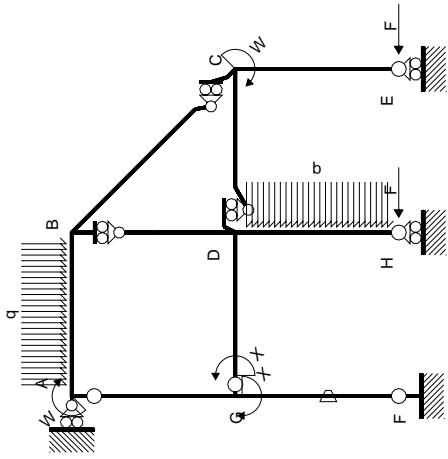

Schema di calcolo iperstatico

M_0 flessione da carichi assegnati

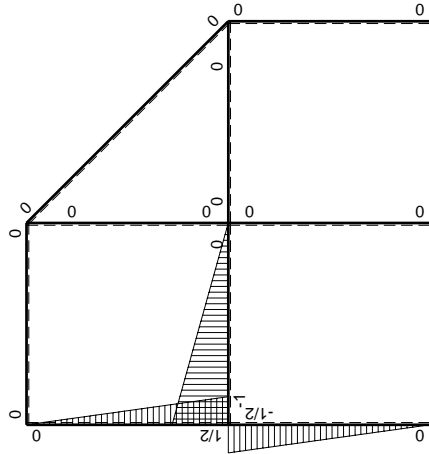

M_1 flessione da iperstatica $X=1$

Quadro contributi PLV per iperstatica $X=W_{GD}$

→	$M_x(x)$	$M_o(x)$	θ	$M_x M_o$	$M_x \theta$	$M_x M_x$	$\int M_x(M_o/EJ+\theta)dx$	$\int X M_x M_x/EJ dx$
AB b	0	$Fb-3/2Fx-1/2qx^2$	0	0	0	0	0+0	0
BA b	0	$Fb-5/2Fx+1/2qx^2$	0	0	0	0	0	0
BC $\sqrt{2}b$	0	$-Fb+\sqrt{2}/2Fx$	0	0	0	0	0	0
BD b	0	0	0	0	0	0	0+0	0
DB b	0	0	0	0	0	0	0	0
DC b	0	$-2Fx$	0	0	0	0	0+0	0
CD b	0	$2Fb-2Fx$	0	0	0	0	0	0
CE b	0	$-Fb+Fx$	0	0	0	0	0+0	0
EC b	0	Fx	0	0	0	0	0	0
FG b	$-1/2x/b$	$-Fx$	$-Fb/EJ$	$1/2Fx^2/b$	$1/2Fx/EJ$	$1/4x^2/b^2$	$(1/6+1/4)Fb^2/EJ$	$1/12Xb/EJ$
GF b	$1/2-1/2x/b$	$Fb-Fx$	Fb/EJ	$1/2Fb-Fx+1/2Fx^2/b$	$1/2Fb/EJ-1/2Fx/EJ$	$1/4-1/2x/b+1/4x^2/b^2$		
GD b	$-1+x/b$	$-3/2Fx$	0	$3/2Fx-3/2Fx^2/b$	0	$1-2x/b+x^2/b^2$	$(1/4+0)Fb^2/EJ$	$1/3Xb/EJ$
DG b	x/b	$3/2Fb-3/2Fx$	0	$3/2Fx-3/2Fx^2/b$	0	x^2/b^2		
DH b	0	$-3/2Fb+2Fx-1/2qx^2$	0	0	0	0	0+0	0
HD b	0	$Fx+1/2qx^2$	0	0	0	0	0	0
GA b	$1/2-1/2x/b$	$-Fb+Fx$	0	$-1/2Fb+Fx-1/2Fx^2/b$	0	$1/4-1/2x/b+1/4x^2/b^2$	$(-1/6+0)Fb^2/EJ$	$1/12Xb/EJ$
AG b	$-1/2x/b$	Fx	0	$-1/2Fx^2/b$	0	$1/4x^2/b^2$		
	totali						$1/2Fb^2/EJ$	$1/2Xb/EJ$
	iperstatica $X=W_{GD}$						$-Fb$	

Sviluppi di calcolo iperstatica

$$L_{FG}^{xx} = \int_0^b (1/4 x^2/b^2) 1/EJ dx = [1/12 x^3/b^2]_0^b 1/EJ$$

$$= (1/12 b) 1/EJ = 1/12 b/EJ$$

$$L_{GF}^{xx} = \int_0^b (1/4 - 1/2 x/b + 1/4 x^2/b^2) 1/EJ dx = [1/4 x - 1/4 x^2/b + 1/12 x^3/b^2]_0^b 1/EJ$$

$$= (1/4 b - 1/4 b + 1/12 b) 1/EJ = 1/12 b/EJ$$

$$L_{GD}^{xx} = \int_0^b (1 - 2 x/b + x^2/b^2) 1/EJ dx = [x - x^2/b + 1/3 x^3/b^2]_0^b 1/EJ$$

$$= (b - b + 1/3 b) 1/EJ = 1/3 b/EJ$$

$$L_{DG}^{xx} = \int_0^b (x^2/b^2) 1/EJ dx = [1/3 x^3/b^2]_0^b 1/EJ$$

$$= (1/3 b) 1/EJ = 1/3 b/EJ$$

$$L_{GA}^{xx} = \int_0^b (1/4 - 1/2 x/b + 1/4 x^2/b^2) 1/EJ dx = [1/4 x - 1/4 x^2/b + 1/12 x^3/b^2]_0^b 1/EJ$$

$$= (1/4 b - 1/4 b + 1/12 b) 1/EJ = 1/12 b/EJ$$

$$L_{AG}^{xx} = \int_0^b (1/4 x^2/b^2) 1/EJ dx = [1/12 x^3/b^2]_0^b 1/EJ$$

$$= (1/12 b) 1/EJ = 1/12 b/EJ$$

$$L_{FG}^{xo} = \int_0^b (1/2 x^2/b^2) Fb 1/EJ dx + \int_0^b (1/2 x/b) \theta dx = [1/6 x^3/b^2]_0^b Fb 1/EJ + [1/4 x^2/b]_0^b \theta$$

$$= (1/6 b) Fb 1/EJ + (1/4 b) \theta = 5/12 Fb^2/EJ$$

$$L_{GF}^{xo} = \int_0^b (1/2 - x/b + 1/2 x^2/b^2) Fb 1/EJ dx + \int_0^b (-1/2 + 1/2 x/b) \theta dx$$

$$= [1/2 x - 1/2 x^2/b + 1/6 x^3/b^2]_0^b Fb 1/EJ + [-1/2 x + 1/4 x^2/b]_0^b \theta$$

$$= (1/2 b - 1/2 b + 1/6 b) Fb 1/EJ + (-1/2 b + 1/4 b) \theta = 5/12 Fb^2/EJ$$

$$L_{GD}^{xo} = \int_0^b (3/2 x/b - 3/2 x^2/b^2) Fb 1/EJ dx = [3/4 x^2/b - 1/2 x^3/b^2]_0^b Fb 1/EJ$$

$$= (3/4 b - 1/2 b) Fb 1/EJ = 1/4 Fb^2/EJ$$

$$L_{DG}^{xo} = \int_0^b (3/2 x/b - 3/2 x^2/b^2) Fb 1/EJ dx = [3/4 x^2/b - 1/2 x^3/b^2]_0^b Fb 1/EJ$$

$$= (3/4 b - 1/2 b) Fb 1/EJ = 1/4 Fb^2/EJ$$

$$L_{GA}^{xo} = \int_0^b (-1/2 + x/b - 1/2 x^2/b^2) Fb 1/EJ dx = [-1/2 x + 1/2 x^2/b - 1/6 x^3/b^2]_0^b Fb 1/EJ$$

$$= (-1/2 b + 1/2 b - 1/6 b) Fb 1/EJ = -1/6 Fb^2/EJ$$

$$L_{AG}^{xo} = \int_0^b (-1/2 x^2/b^2) Fb 1/EJ dx = [-1/6 x^3/b^2]_0^b Fb 1/EJ$$

$$= (-1/6 b) Fb 1/EJ = -1/6 Fb^2/EJ$$

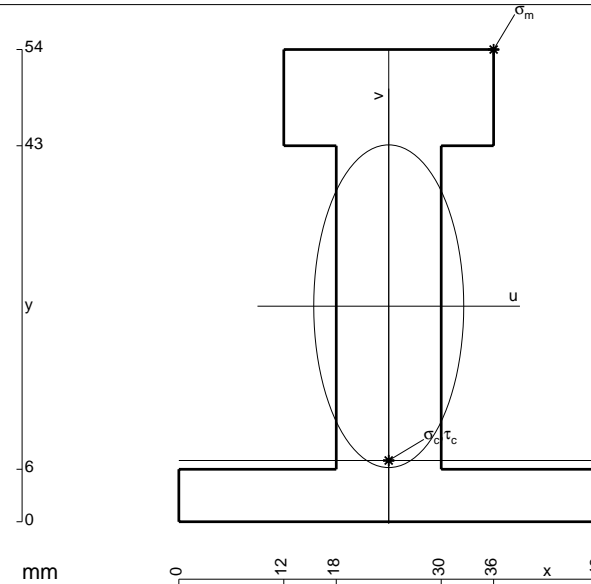

- A = 996. mm²
- J_u = 339350. mm⁴
- J_v = 73296. mm⁴
- y_g = 24.64 mm
- T_y = -4520. N
- M_x = -2305200. Nmm
- x_m = 36. mm
- y_m = 54. mm
- u_m = 12. mm
- v_m = 29.36 mm
- σ_m = -Mv/J_u = 199.4 N/mm²
- x_c = 24. mm
- y_c = 7. mm
- v_c = -17.64 mm
- σ_c = -Mv/J_u = -119.9 N/mm²
- τ_c = 7.161 N/mm²
- σ_q = √σ²+3τ² = 120.5 N/mm²
- S = 6451. mm³

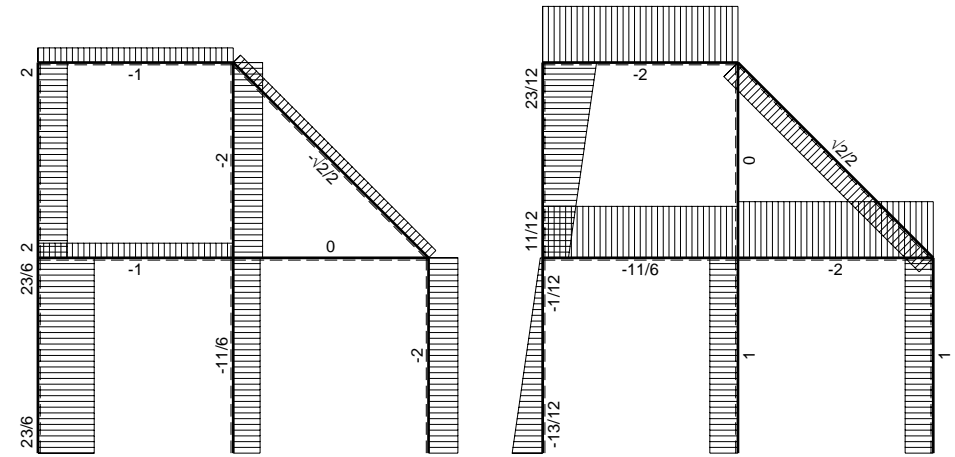
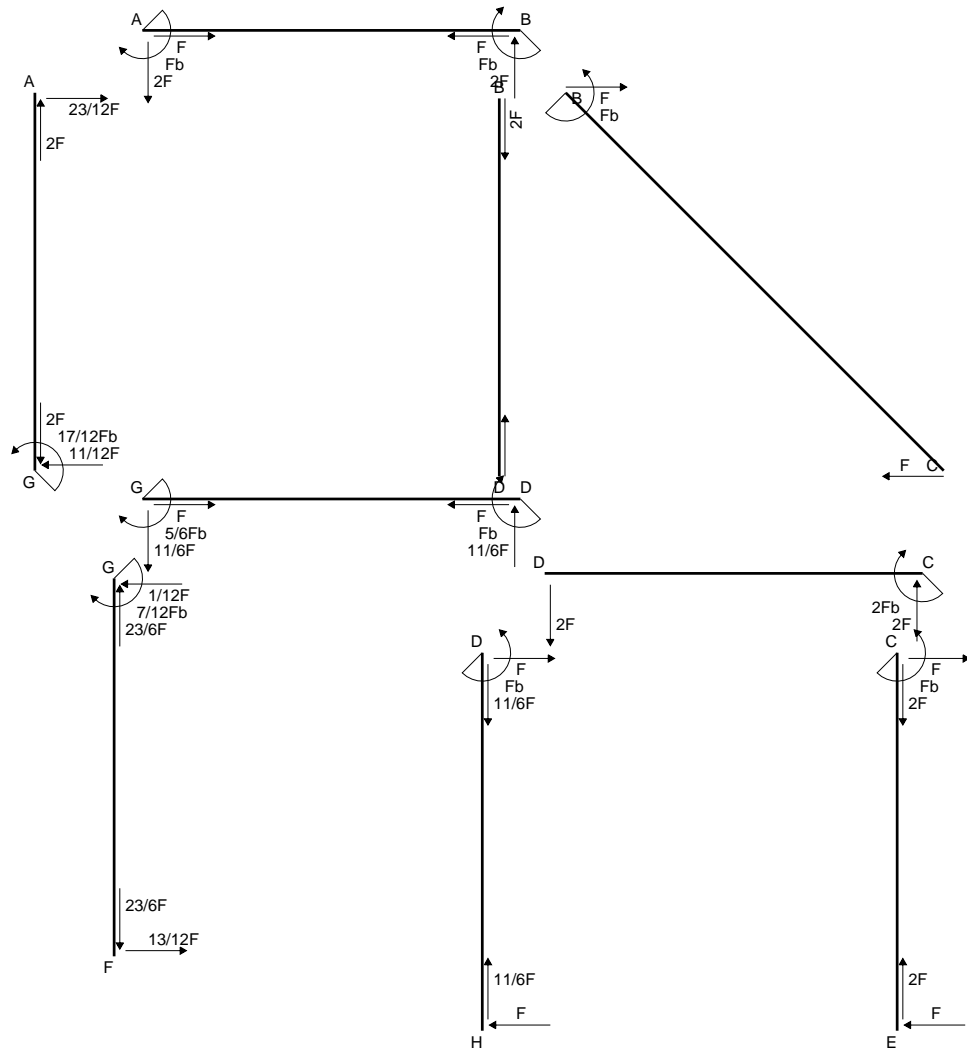

← ⊕ → F

↑ ⊕ ↓ F

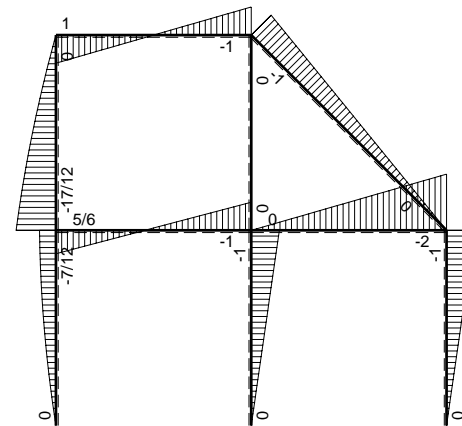

⊕ ⊖ F_b

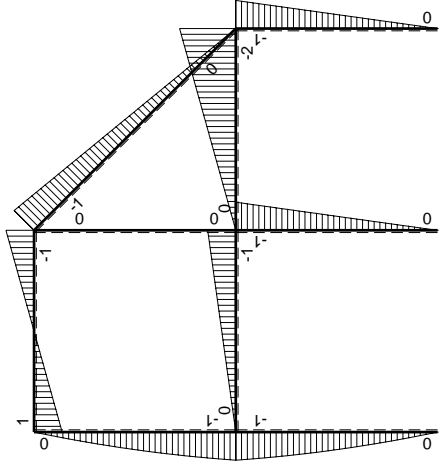
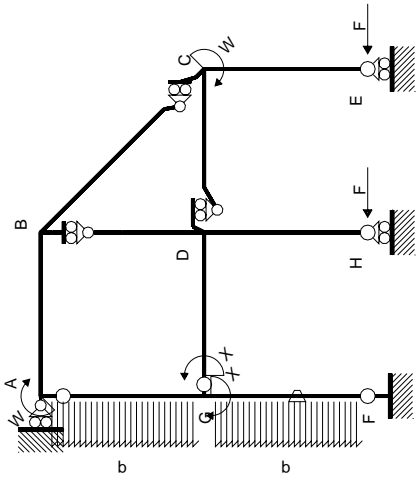

Schema di calcolo iperstatico

M_0 flessione da carichi assegnati

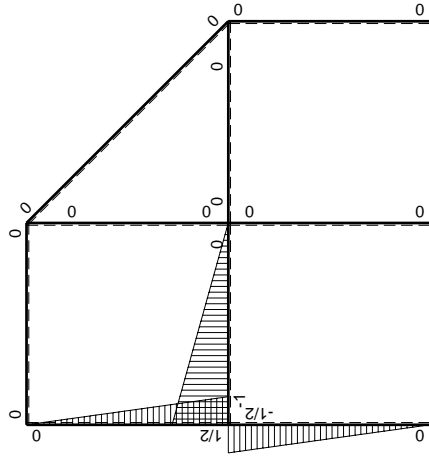

M_x flessione da iperstatica $X=1$

Quadro contributi PLV per iperstatica $X=W_{GD}$

→	$M_x(x)$	$M_o(x)$	θ	$M_x M_o$	$M_x \theta$	$M_x M_x$	$\int M_x(M_o/EJ+\theta)dx$	$\int X M_x M_x / EJ dx$
AB b	0	Fb-2Fx	0	0	0	0	0+0	0
BA b	0	Fb-2Fx	0	0	0	0		
BC $\sqrt{2}b$	0	-Fb+ $\sqrt{2}/2Fx$	0	0	0	0	0	0
BD b	0	0	0	0	0	0	0+0	0
DB b	0	0	0	0	0	0		
DC b	0	-2Fx	0	0	0	0	0+0	0
CD b	0	2Fb-2Fx	0	0	0	0		
CE b	0	-Fb+Fx	0	0	0	0	0+0	0
EC b	0	Fx	0	0	0	0		
FG b	-1/2x/b	-3/2Fx+1/2qx ²	-Fb/EJ	3/4Fx ² /b-1/4qx ³ /b	1/2Fx/EJ	1/4x ² /b ²	(3/16+1/4)Fb ² /EJ	1/12Xb/EJ
GF b	1/2-1/2x/b	Fb-1/2Fx-1/2qx ²	Fb/EJ	1/2Fb-3/4Fx+1/4qx ³ /b	1/2Fb/EJ-1/2Fx/EJ	1/4-1/2x/b+1/4x ² /b ²		
GD b	-1+x/b	-Fx	0	Fx-Fx ² /b	0	1-2x/b+x ² /b ²	(1/6+0)Fb ² /EJ	1/3Xb/EJ
DG b	x/b	Fb-Fx	0	Fx-Fx ² /b	0	x ² /b ²		
DH b	0	-Fb+Fx	0	0	0	0	0+0	0
HD b	0	Fx	0	0	0	0		
GA b	1/2-1/2x/b	-Fb+1/2Fx+1/2qx ²	0	-1/2Fb+3/4Fx-1/4qx ³ /b	0	1/4-1/2x/b+1/4x ² /b ²	(-3/16+0)Fb ² /EJ	1/12Xb/EJ
AG b	-1/2x/b	3/2Fx-1/2qx ²	0	-3/4Fx ² /b+1/4qx ³ /b	0	1/4x ² /b ²		
	totali						5/12Fb ² /EJ	1/2Xb/EJ
	iperstatica $X=W_{GD}$						-5/6Fb	

Sviluppi di calcolo iperstatica

$$L_{FG}^{xx} = \int_0^b (1/4 x^2/b^2) 1/EJ dx = [1/12 x^3/b^2]_0^b 1/EJ$$

$$= (1/12 b) 1/EJ = 1/12 b/EJ$$

$$L_{GF}^{xx} = \int_0^b (1/4 - 1/2 x/b + 1/4 x^2/b^2) 1/EJ dx = [1/4 x - 1/4 x^2/b + 1/12 x^3/b^2]_0^b 1/EJ$$

$$= (1/4 b - 1/4 b + 1/12 b) 1/EJ = 1/12 b/EJ$$

$$L_{GD}^{xx} = \int_0^b (1 - 2 x/b + x^2/b^2) 1/EJ dx = [x - x^2/b + 1/3 x^3/b^2]_0^b 1/EJ$$

$$= (b - b + 1/3 b) 1/EJ = 1/3 b/EJ$$

$$L_{DG}^{xx} = \int_0^b (x^2/b^2) 1/EJ dx = [1/3 x^3/b^2]_0^b 1/EJ$$

$$= (1/3 b) 1/EJ = 1/3 b/EJ$$

$$L_{GA}^{xx} = \int_0^b (1/4 - 1/2 x/b + 1/4 x^2/b^2) 1/EJ dx = [1/4 x - 1/4 x^2/b + 1/12 x^3/b^2]_0^b 1/EJ$$

$$= (1/4 b - 1/4 b + 1/12 b) 1/EJ = 1/12 b/EJ$$

$$L_{AG}^{xx} = \int_0^b (1/4 x^2/b^2) 1/EJ dx = [1/12 x^3/b^2]_0^b 1/EJ$$

$$= (1/12 b) 1/EJ = 1/12 b/EJ$$

$$L_{FG}^{x\theta} = \int_0^b (3/4 x^2/b^2 - 1/4 x^3/b^3) Fb 1/EJ dx + \int_0^b (1/2 x/b) \theta dx$$

$$= [1/4 x^3/b^2 - 1/16 x^4/b^3]_0^b Fb 1/EJ + [1/4 x^2/b]_0^b \theta$$

$$= (1/4 b - 1/16 b) Fb 1/EJ + (1/4 b) \theta = 7/16 Fb^2/EJ$$

$$L_{GF}^{x\theta} = \int_0^b (1/2 - 3/4 x/b + 1/4 x^2/b^2) Fb 1/EJ dx + \int_0^b (-1/2 + 1/2 x/b) \theta dx$$

$$= [1/2 x - 3/8 x^2/b + 1/16 x^3/b^2]_0^b Fb 1/EJ + [-1/2 x + 1/4 x^2/b]_0^b \theta$$

$$= (1/2 b - 3/8 b + 1/16 b) Fb 1/EJ + (-1/2 b + 1/4 b) \theta = 7/16 Fb^2/EJ$$

$$L_{GD}^{x\theta} = \int_0^b (x/b - x^2/b^2) Fb 1/EJ dx = [1/2 x^2/b - 1/3 x^3/b^2]_0^b Fb 1/EJ$$

$$= (1/2 b - 1/3 b) Fb 1/EJ = 1/6 Fb^2/EJ$$

$$L_{DG}^{x\theta} = \int_0^b (x/b - x^2/b^2) Fb 1/EJ dx = [1/2 x^2/b - 1/3 x^3/b^2]_0^b Fb 1/EJ$$

$$= (1/2 b - 1/3 b) Fb 1/EJ = 1/6 Fb^2/EJ$$

$$L_{GA}^{x\theta} = \int_0^b (-1/2 + 3/4 x/b - 1/4 x^2/b^2) Fb 1/EJ dx = [-1/2 x + 3/8 x^2/b - 1/16 x^3/b^2]_0^b Fb 1/EJ$$

$$= (-1/2 b + 3/8 b - 1/16 b) Fb 1/EJ = -3/16 Fb^2/EJ$$

$$L_{AG}^{x\theta} = \int_0^b (-3/4 x^2/b^2 + 1/4 x^3/b^3) Fb 1/EJ dx = [-1/4 x^3/b^2 + 1/16 x^4/b^3]_0^b Fb 1/EJ$$

$$= (-1/4 b + 1/16 b) Fb 1/EJ = -3/16 Fb^2/EJ$$

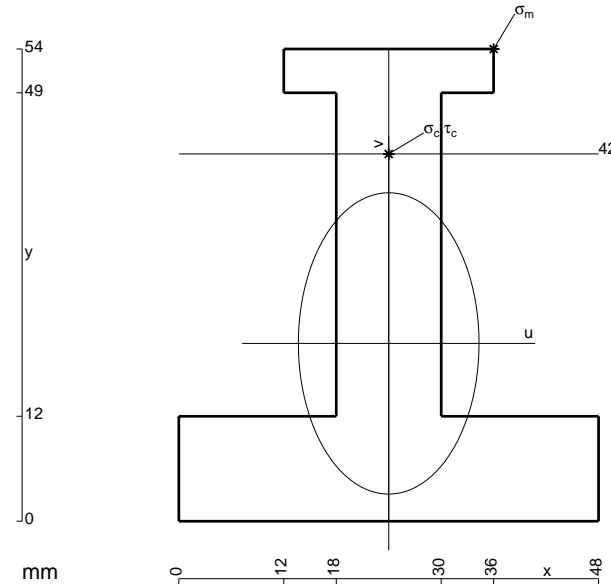

- A = 1140. mm²
- J_u = 338607. mm⁴
- J_v = 121680. mm⁴
- y_g = 20.33 mm
- T_y = -3760. N
- M_x = -2105600. Nmm
- x_m = 36. mm
- y_m = 54. mm
- u_m = 12. mm
- v_m = 33.67 mm
- σ_m = -Mv/J_u = 209.4 N/mm²
- x_c = 24. mm
- y_c = 42. mm
- v_c = 21.67 mm
- σ_c = -Mv/J_u = 134.7 N/mm²
- τ_c = 5.417 N/mm²
- σ_σ = √σ²+3τ² = 135.1 N/mm²
- S = 5854. mm³

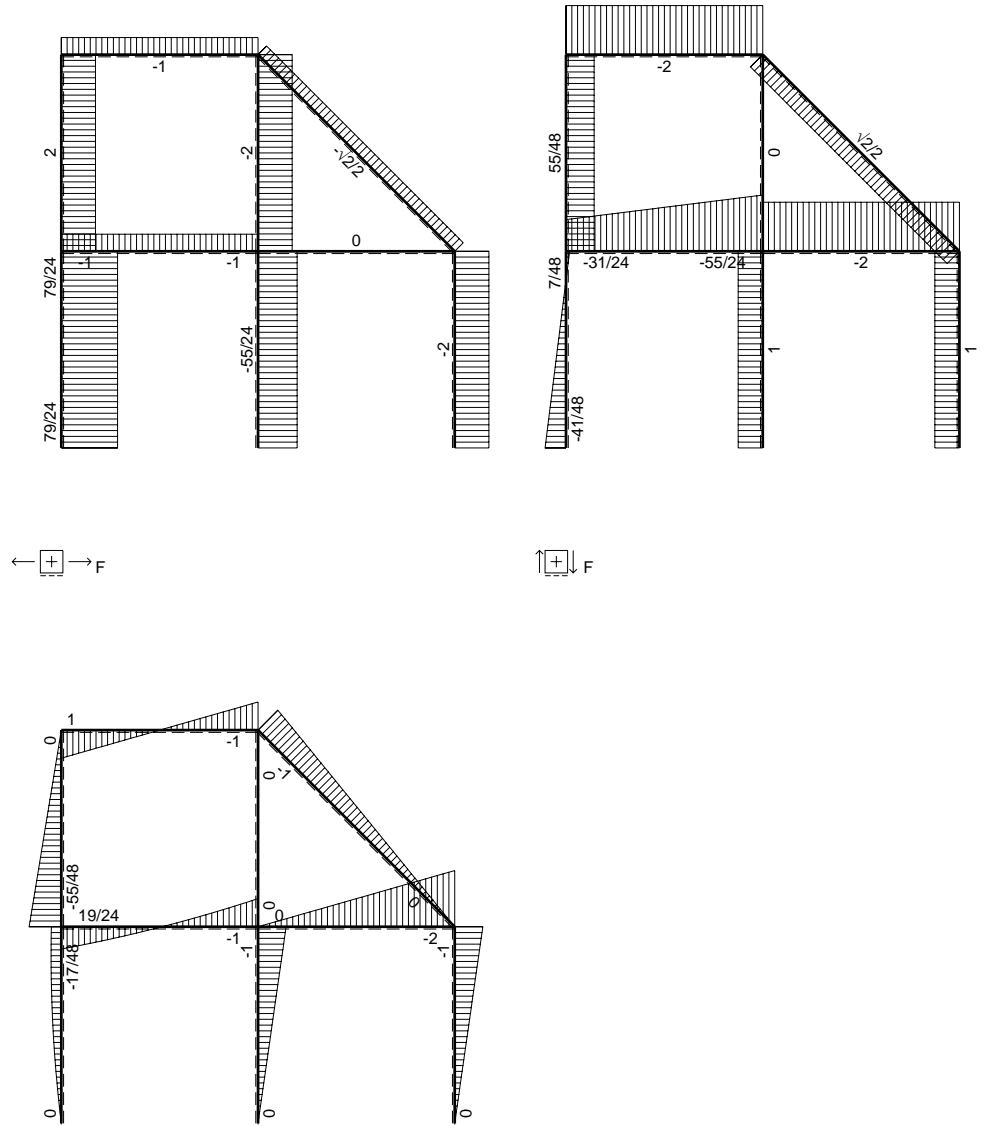
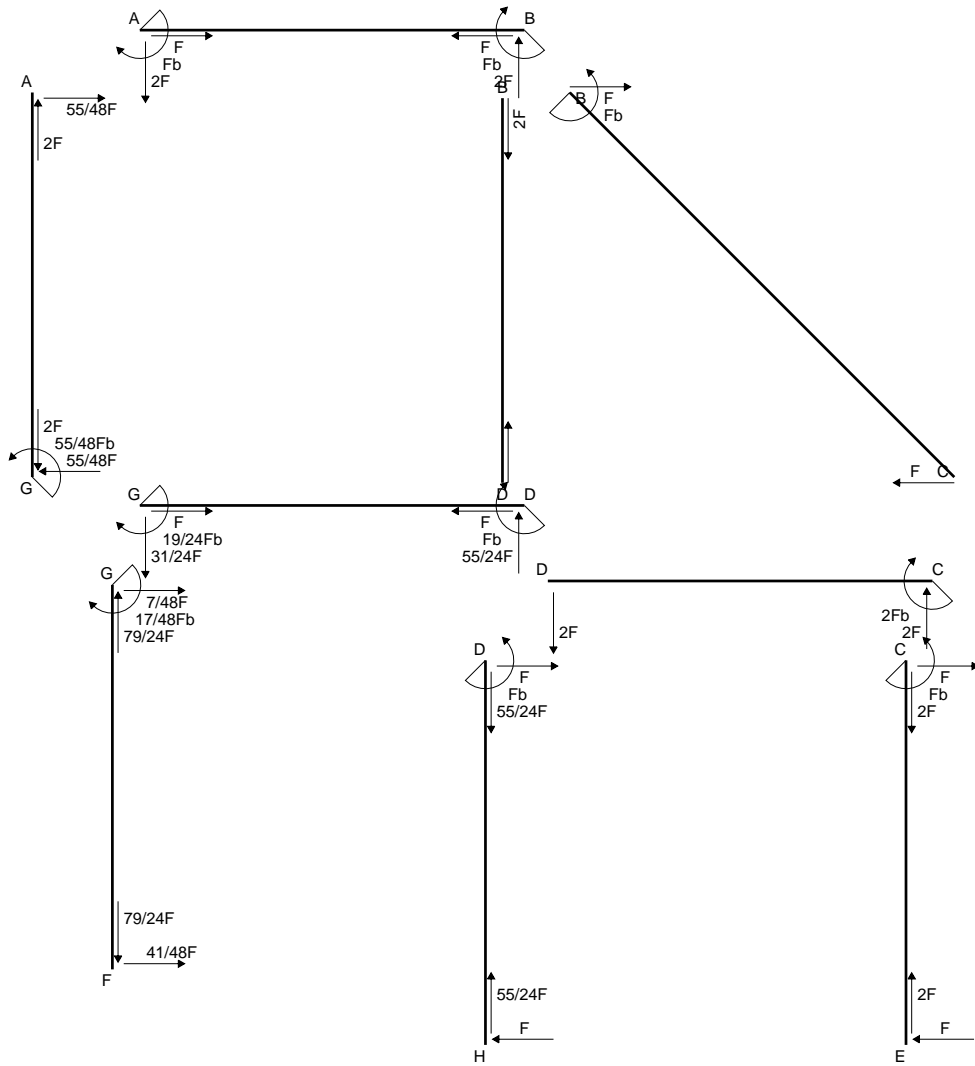

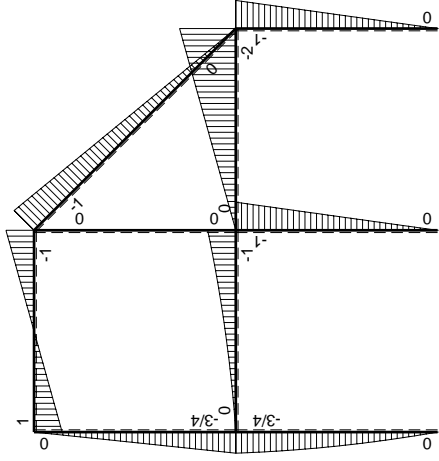
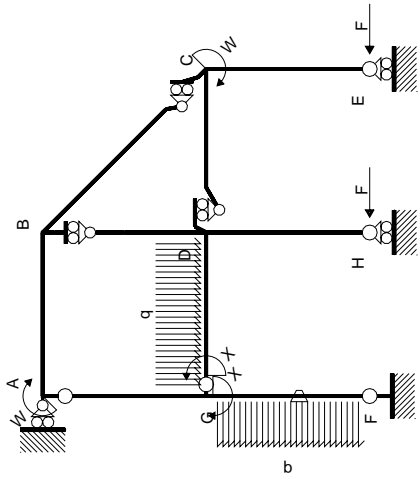

Schema di calcolo iperstatico

M_0 , flessione da carichi assegnati

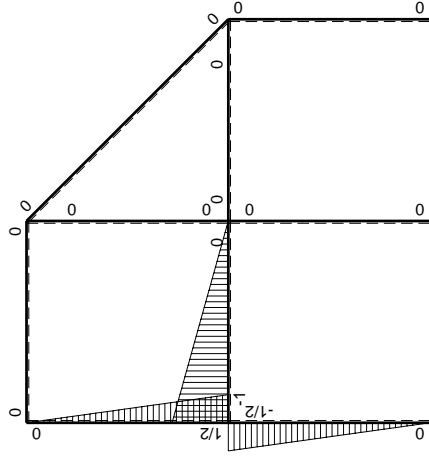

M_x , flessione da iperstatica $X=1$

Quadro contributi PLV per iperstatica $X=W_{GD}$

→	$M_x(x)$	$M_o(x)$	θ	$M_x M_o$	$M_x \theta$	$M_x M_x$	$\int M_x(M_o/EJ+\theta)dx$	$\int x M_x M_x/EJ dx$
AB b	0	Fb-2Fx	0	0	0	0	0+0	0
BA b	0	Fb-2Fx	0	0	0	0	0	0
BC $\sqrt{2}b$	0	-Fb+ $\sqrt{2}/2Fx$	0	0	0	0	0	0
BD b	0	0	0	0	0	0	0+0	0
DB b	0	0	0	0	0	0	0	0
DC b	0	-2Fx	0	0	0	0	0+0	0
CD b	0	2Fb-2Fx	0	0	0	0	0	0
CE b	0	-Fb+Fx	0	0	0	0	0+0	0
EC b	0	Fx	0	0	0	0	0	0
FG b	-1/2x/b	-5/4Fx+1/2qx ²	-Fb/EJ	5/8Fx ² /b-1/4qx ³ /b	1/2Fx/EJ	1/4x ² /b ²	(7/48+1/4)Fb ² /EJ	1/12Xb/EJ
GF b	1/2-1/2x/b	3/4Fb-1/4Fx-1/2qx ²	Fb/EJ	3/8Fb-1/2Fx-1/8Fx ² /b+1/4qx ³ /b	1/2Fb/EJ-1/2Fx/EJ	1/4-1/2x/b+1/4x ² /b ²		
GD b	-1+x/b	-1/2Fx-1/2qx ²	0	1/2Fx-1/2qx ³ /b	0	1-2x/b+x ² /b ²	(1/8+0)Fb ² /EJ	1/3Xb/EJ
DG b	x/b	Fb-3/2Fx+1/2qx ²	0	Fx-3/2Fx ² /b+1/2qx ³ /b	0	x ² /b ²		
DH b	0	-Fb+Fx	0	0	0	0	0+0	0
HD b	0	Fx	0	0	0	0		
GA b	1/2-1/2x/b	-3/4Fb+3/4Fx	0	-3/8Fb+3/4Fx-3/8Fx ² /b	0	1/4-1/2x/b+1/4x ² /b ²	(-1/8+0)Fb ² /EJ	1/12Xb/EJ
AG b	-1/2x/b	3/4Fx	0	-3/8Fx ² /b	0	1/4x ² /b ²		
	totali						19/48Fb ² /EJ	1/2Xb/EJ
	iperstatica $X=W_{GD}$						-19/24Fb	

Sviluppi di calcolo iperstatica

$$L_{FG}^{xx} = \int_0^b (1/4 x^2/b^2) 1/EJ dx = [1/12 x^3/b^2]_0^b 1/EJ$$

$$= (1/12 b) 1/EJ = 1/12 b/EJ$$

$$L_{GF}^{xx} = \int_0^b (1/4 - 1/2 x/b + 1/4 x^2/b^2) 1/EJ dx = [1/4 x - 1/4 x^2/b + 1/12 x^3/b^2]_0^b 1/EJ$$

$$= (1/4 b - 1/4 b + 1/12 b) 1/EJ = 1/12 b/EJ$$

$$L_{GD}^{xx} = \int_0^b (1 - 2 x/b + x^2/b^2) 1/EJ dx = [x - x^2/b + 1/3 x^3/b^2]_0^b 1/EJ$$

$$= (b - b + 1/3 b) 1/EJ = 1/3 b/EJ$$

$$L_{DG}^{xx} = \int_0^b (x^2/b^2) 1/EJ dx = [1/3 x^3/b^2]_0^b 1/EJ$$

$$= (1/3 b) 1/EJ = 1/3 b/EJ$$

$$L_{GA}^{xx} = \int_0^b (1/4 - 1/2 x/b + 1/4 x^2/b^2) 1/EJ dx = [1/4 x - 1/4 x^2/b + 1/12 x^3/b^2]_0^b 1/EJ$$

$$= (1/4 b - 1/4 b + 1/12 b) 1/EJ = 1/12 b/EJ$$

$$L_{AG}^{xx} = \int_0^b (1/4 x^2/b^2) 1/EJ dx = [1/12 x^3/b^2]_0^b 1/EJ$$

$$= (1/12 b) 1/EJ = 1/12 b/EJ$$

$$L_{FG}^{xo} = \int_0^b (5/8 x^2/b^2 - 1/4 x^3/b^3) Fb 1/EJ dx + \int_0^b (1/2 x/b) \theta dx$$

$$= [5/24 x^3/b^2 - 1/16 x^4/b^3]_0^b Fb 1/EJ + [1/4 x^2/b]_0^b \theta$$

$$= (5/24 b - 1/16 b) Fb 1/EJ + (1/4 b) \theta = 19/48 Fb^2/EJ$$

$$L_{GF}^{xo} = \int_0^b (3/8 - 1/2 x/b - 1/8 x^2/b^2 + 1/4 x^3/b^3) Fb 1/EJ dx + \int_0^b (-1/2 + 1/2 x/b) \theta dx$$

$$= [3/8 x - 1/4 x^2/b - 1/24 x^3/b^2 + 1/16 x^4/b^3]_0^b Fb 1/EJ + [-1/2 x + 1/4 x^2/b]_0^b \theta$$

$$= (3/8 b - 1/4 b - 1/24 b + 1/16 b) Fb 1/EJ + (-1/2 b + 1/4 b) \theta = 19/48 Fb^2/EJ$$

$$L_{GD}^{xo} = \int_0^b (1/2 x/b - 1/2 x^3/b^3) Fb 1/EJ dx = [1/4 x^2/b - 1/8 x^4/b^3]_0^b Fb 1/EJ$$

$$= (1/4 b - 1/8 b) Fb 1/EJ = 1/8 Fb^2/EJ$$

$$L_{DG}^{xo} = \int_0^b (x/b - 3/2 x^2/b^2 + 1/2 x^3/b^3) Fb 1/EJ dx = [1/2 x^2/b - 1/2 x^3/b^2 + 1/8 x^4/b^3]_0^b Fb 1/EJ$$

$$= (1/2 b - 1/2 b + 1/8 b) Fb 1/EJ = 1/8 Fb^2/EJ$$

$$L_{GA}^{xo} = \int_0^b (-3/8 + 3/4 x/b - 3/8 x^2/b^2) Fb 1/EJ dx = [-3/8 x + 3/8 x^2/b - 1/8 x^3/b^2]_0^b Fb 1/EJ$$

$$= (-3/8 b + 3/8 b - 1/8 b) Fb 1/EJ = -1/8 Fb^2/EJ$$

$$L_{AG}^{xo} = \int_0^b (-3/8 x^2/b^2) Fb 1/EJ dx = [-1/8 x^3/b^2]_0^b Fb 1/EJ$$

$$= (-1/8 b) Fb 1/EJ = -1/8 Fb^2/EJ$$

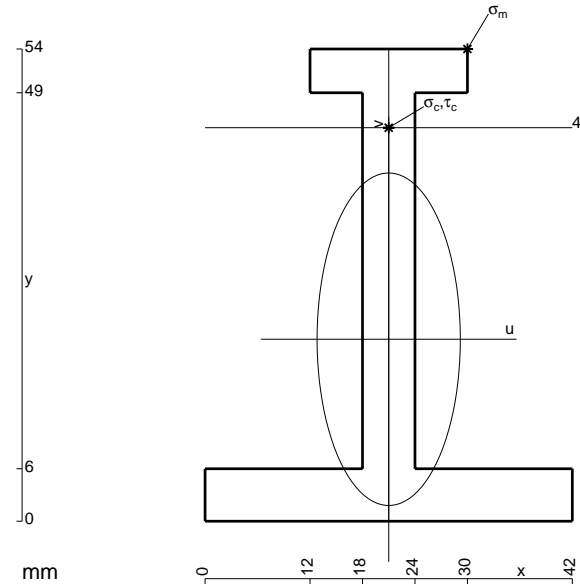

- A = 600. mm²
- J_u = 216946. mm⁴
- J_v = 40248. mm⁴
- y_g = 20.81 mm
- T_y = -2340. N
- M_x = -1427400. Nmm
- x_m = 30. mm
- y_m = 54. mm
- u_m = 9. mm
- v_m = 33.19 mm
- σ_m = -Mv/J_u = 218.4 N/mm²
- x_c = 21. mm
- y_c = 45. mm
- v_c = 24.19 mm
- σ_c = -Mv/J_v = 159.2 N/mm²
- τ_c = 6.095 N/mm²
- σ_o = √σ²+3τ² = 159.5 N/mm²
- S = 3391. mm³

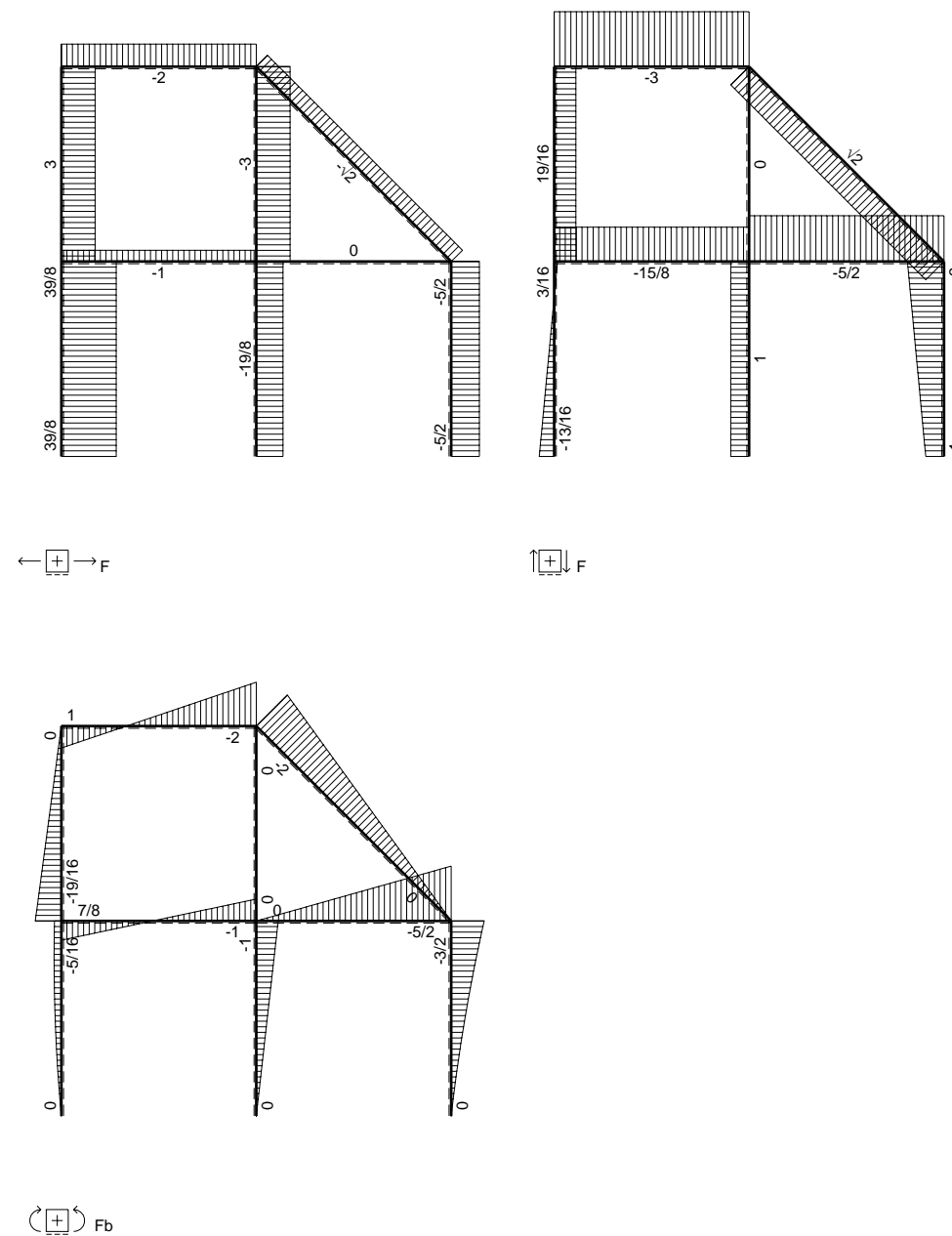
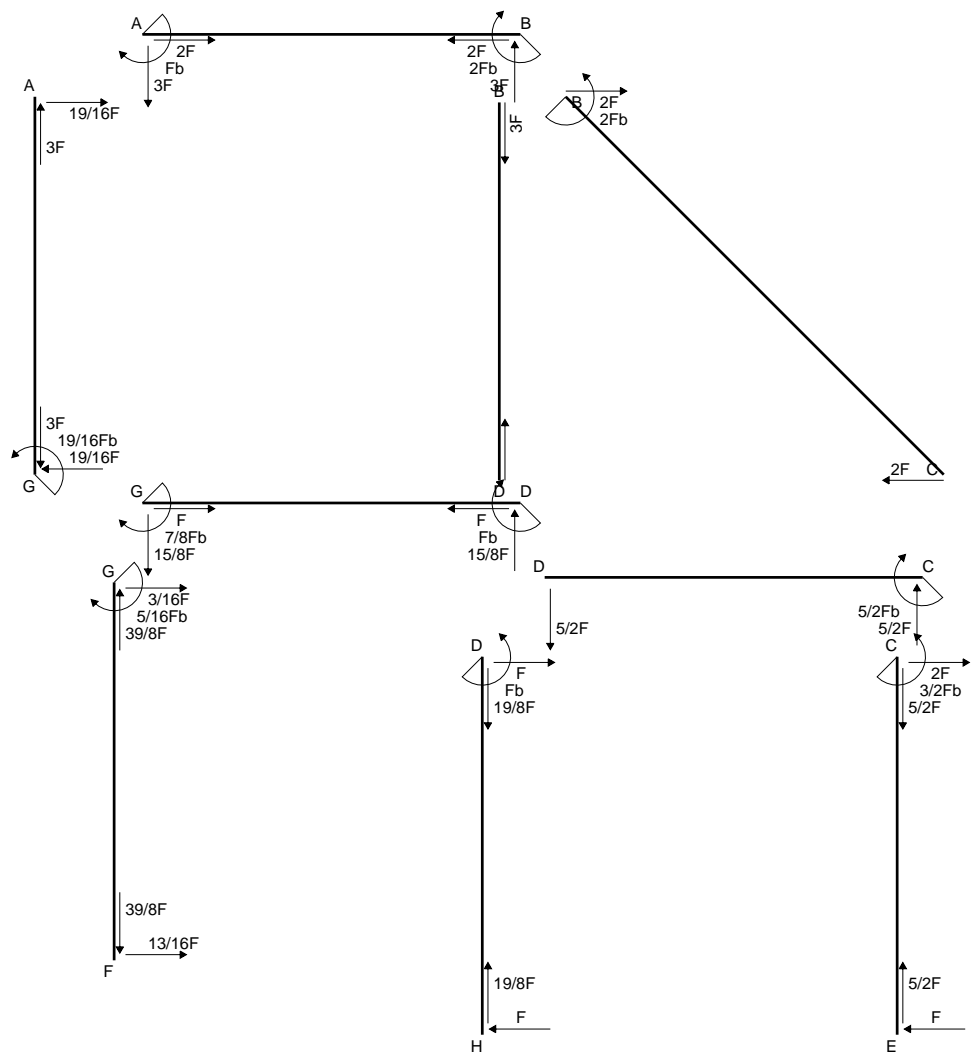

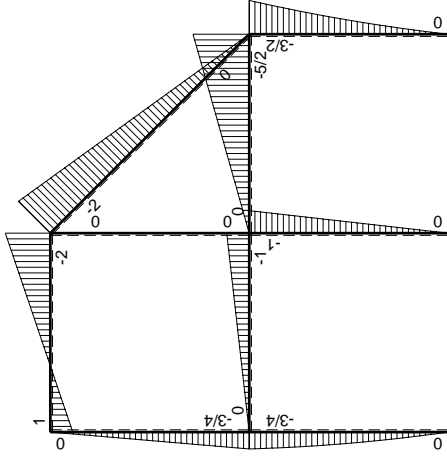
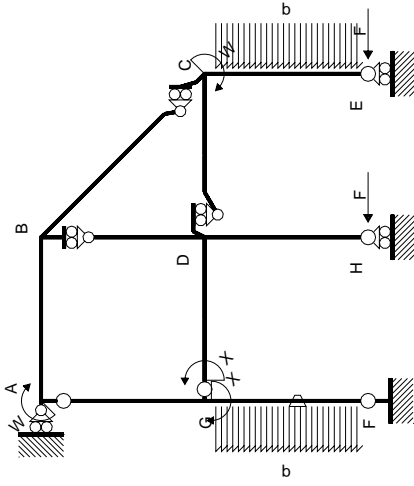

Schema di calcolo iperstatico

M_0 flessione da carichi assegnati

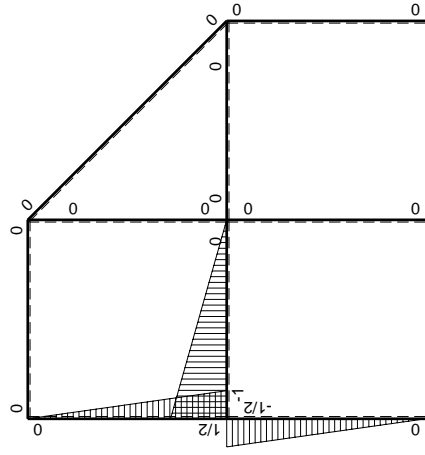

M_x flessione da iperstatica $X=1$

Quadro contributi PLV per iperstatica $X=W_{GD}$

→	$M_x(x)$	$M_o(x)$	θ	$M_x M_o$	$M_x \theta$	$M_x M_x$	$\int M_x(M_o/EJ+\theta)dx$	$\int x M_x M_x/EJ dx$
AB b	0	$Fb-3Fx$	0	0	0	0	0+0	0
BA b	0	$2Fb-3Fx$	0	0	0	0		
BC $\sqrt{2}b$	0	$-2Fb+\sqrt{2}Fx$	0	0	0	0	0	0
BD b	0	0	0	0	0	0	0+0	0
DB b	0	0	0	0	0	0		
DC b	0	$-5/2Fx$	0	0	0	0	0+0	0
CD b	0	$5/2Fb-5/2Fx$	0	0	0	0		
CE b	0	$-3/2Fb+2Fx-1/2qx^2$	0	0	0	0	0+0	0
EC b	0	$Fx+1/2qx^2$	0	0	0	0		
FG b	$-1/2x/b$	$-5/4Fx+1/2qx^2$	$-Fb/EJ$	$5/8Fx^2/b-1/4qx^3/b$	$1/2Fx/EJ$	$1/4x^2/b^2$	$(7/48+1/4)Fb^2/EJ$	$1/12Xb/EJ$
GF b	$1/2-1/2x/b$	$3/4Fb-1/4Fx-1/2qx^2$	Fb/EJ	$3/8Fb-1/2Fx-1/8Fx^2/b+1/4qx^3/b$	$1/2Fb/EJ-1/2Fx/EJ$	$1/4-1/2x/b+1/4x^2/b^2$		
GD b	$-1+x/b$	$-Fx$	0	$Fx-Fx^2/b$	0	$1-2x/b+x^2/b^2$	$(1/6+0)Fb^2/EJ$	$1/3Xb/EJ$
DG b	x/b	$Fb-Fx$	0	$Fx-Fx^2/b$	0	x^2/b^2		
DH b	0	$-Fb+Fx$	0	0	0	0	0+0	0
HD b	0	Fx	0	0	0	0		
GA b	$1/2-1/2x/b$	$-3/4Fb+3/4Fx$	0	$-3/8Fb+3/4Fx-3/8Fx^2/b$	0	$1/4-1/2x/b+1/4x^2/b^2$	$(-1/8+0)Fb^2/EJ$	$1/12Xb/EJ$
AG b	$-1/2x/b$	$3/4Fx$	0	$-3/8Fx^2/b$	0	$1/4x^2/b^2$		
	totali						$7/16Fb^2/EJ$	$1/2Xb/EJ$
	iperstatica $X=W_{GD}$						$-7/8Fb$	

Sviluppi di calcolo iperstatica

$$L_{FG}^{xx} = \int_0^b (1/4 x^2/b^2) 1/EJ dx = [1/12 x^3/b^2]_0^b 1/EJ$$

$$= (1/12 b) 1/EJ = 1/12 b/EJ$$

$$L_{GF}^{xx} = \int_0^b (1/4 - 1/2 x/b + 1/4 x^2/b^2) 1/EJ dx = [1/4 x - 1/4 x^2/b + 1/12 x^3/b^2]_0^b 1/EJ$$

$$= (1/4 b - 1/4 b + 1/12 b) 1/EJ = 1/12 b/EJ$$

$$L_{GD}^{xx} = \int_0^b (1 - 2 x/b + x^2/b^2) 1/EJ dx = [x - x^2/b + 1/3 x^3/b^2]_0^b 1/EJ$$

$$= (b - b + 1/3 b) 1/EJ = 1/3 b/EJ$$

$$L_{DG}^{xx} = \int_0^b (x^2/b^2) 1/EJ dx = [1/3 x^3/b^2]_0^b 1/EJ$$

$$= (1/3 b) 1/EJ = 1/3 b/EJ$$

$$L_{GA}^{xx} = \int_0^b (1/4 - 1/2 x/b + 1/4 x^2/b^2) 1/EJ dx = [1/4 x - 1/4 x^2/b + 1/12 x^3/b^2]_0^b 1/EJ$$

$$= (1/4 b - 1/4 b + 1/12 b) 1/EJ = 1/12 b/EJ$$

$$L_{AG}^{xx} = \int_0^b (1/4 x^2/b^2) 1/EJ dx = [1/12 x^3/b^2]_0^b 1/EJ$$

$$= (1/12 b) 1/EJ = 1/12 b/EJ$$

$$L_{FG}^{xo} = \int_0^b (5/8 x^2/b^2 - 1/4 x^3/b^3) Fb 1/EJ dx + \int_0^b (1/2 x/b) \theta dx$$

$$= [5/24 x^3/b^2 - 1/16 x^4/b^3]_0^b Fb 1/EJ + [1/4 x^2/b]_0^b \theta$$

$$= (5/24 b - 1/16 b) Fb 1/EJ + (1/4 b) \theta = 19/48 Fb^2/EJ$$

$$L_{GF}^{xo} = \int_0^b (3/8 - 1/2 x/b - 1/8 x^2/b^2 + 1/4 x^3/b^3) Fb 1/EJ dx + \int_0^b (-1/2 + 1/2 x/b) \theta dx$$

$$= [3/8 x - 1/4 x^2/b - 1/24 x^3/b^2 + 1/16 x^4/b^3]_0^b Fb 1/EJ + [-1/2 x + 1/4 x^2/b]_0^b \theta$$

$$= (3/8 b - 1/4 b - 1/24 b + 1/16 b) Fb 1/EJ + (-1/2 b + 1/4 b) \theta = 19/48 Fb^2/EJ$$

$$L_{GD}^{xo} = \int_0^b (x/b - x^2/b^2) Fb 1/EJ dx = [1/2 x^2/b - 1/3 x^3/b^2]_0^b Fb 1/EJ$$

$$= (1/2 b - 1/3 b) Fb 1/EJ = 1/6 Fb^2/EJ$$

$$L_{DG}^{xo} = \int_0^b (x/b - x^2/b^2) Fb 1/EJ dx = [1/2 x^2/b - 1/3 x^3/b^2]_0^b Fb 1/EJ$$

$$= (1/2 b - 1/3 b) Fb 1/EJ = 1/6 Fb^2/EJ$$

$$L_{GA}^{xo} = \int_0^b (-3/8 + 3/4 x/b - 3/8 x^2/b^2) Fb 1/EJ dx = [-3/8 x + 3/8 x^2/b - 1/8 x^3/b^2]_0^b Fb 1/EJ$$

$$= (-3/8 b + 3/8 b - 1/8 b) Fb 1/EJ = -1/8 Fb^2/EJ$$

$$L_{AG}^{xo} = \int_0^b (-3/8 x^2/b^2) Fb 1/EJ dx = [-1/8 x^3/b^2]_0^b Fb 1/EJ$$

$$= (-1/8 b) Fb 1/EJ = -1/8 Fb^2/EJ$$

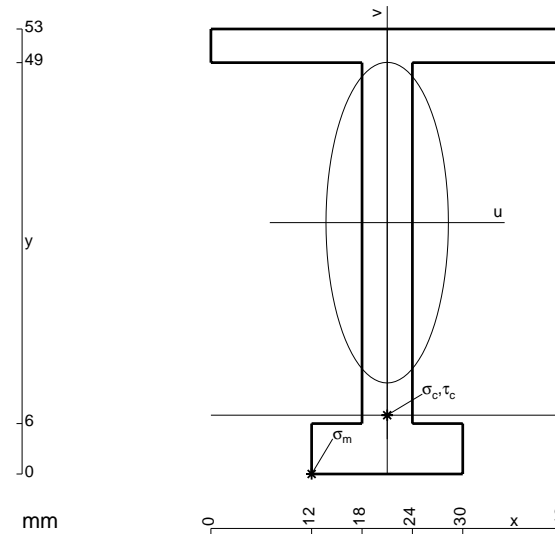

- A = 534. mm²
- J_u = 194732. mm⁴
- J_v = 28386. mm⁴
- y_g = 29.94 mm
- T_y = -2300. N
- M_x = -1495000. Nmm
- x_m = 12. mm
- u_m = -9. mm
- v_m = -29.94 mm
- σ_m = -Mv/J_u = -229.8 N/mm²
- x_c = 21. mm
- y_c = 7. mm
- v_c = -22.94 mm
- σ_c = -Mv/J_u = -176.1 N/mm²
- τ_c = 6.004 N/mm²
- σ_q = √σ²+3τ² = 176.4 N/mm²
- S = 3050. mm³

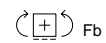
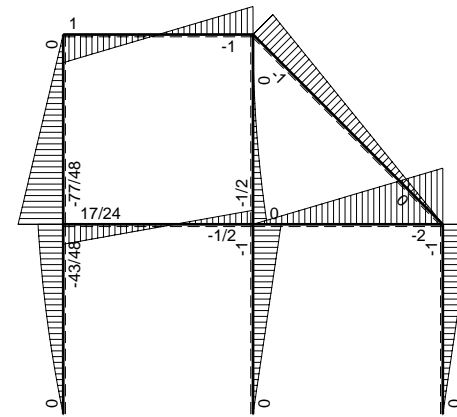
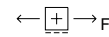
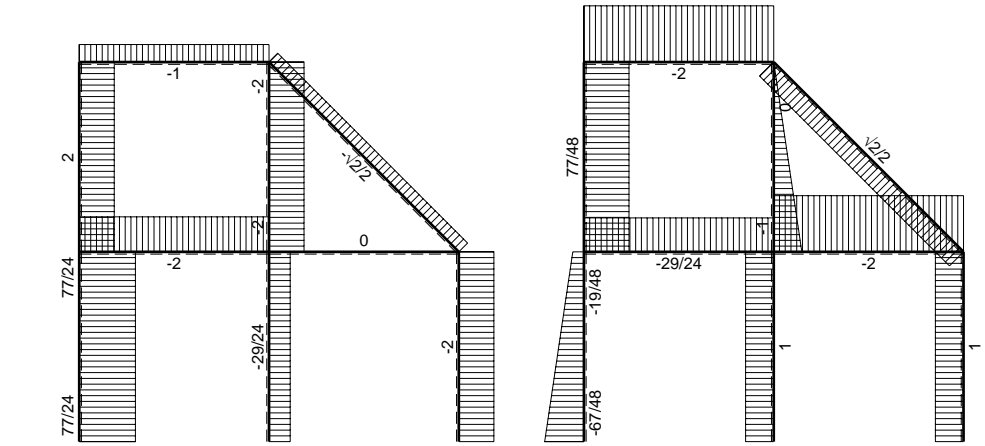
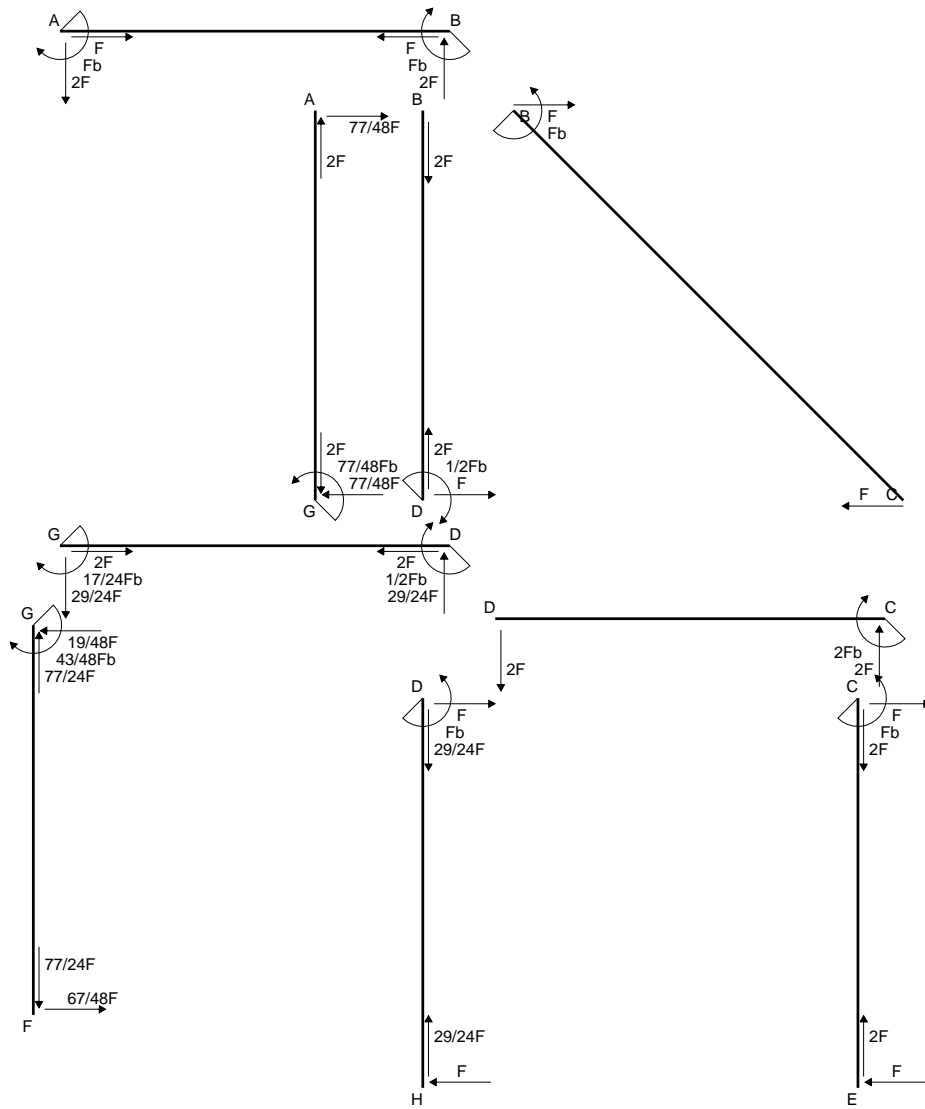

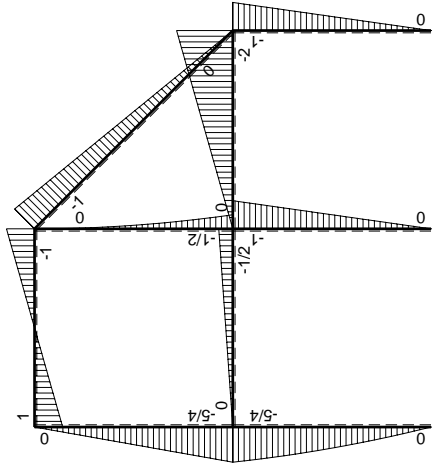
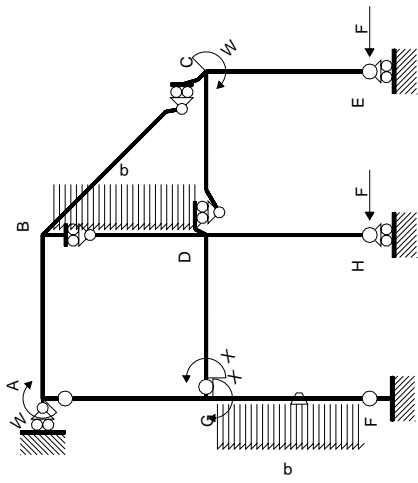

Schema di calcolo iperstatico

M_0 flessione da carichi assegnati

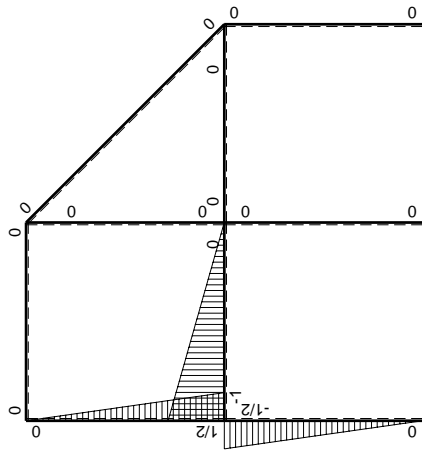

M_x flessione da iperstatica $X=1$

Quadro contributi PLV per iperstatica $X=W_{GD}$

→	$M_x(x)$	$M_o(x)$	θ	$M_x M_o$	$M_x \theta$	$M_x M_x$	$\int M_x(M_o/EJ+\theta)dx$	$\int X M_x M_x / EJ dx$
AB b	0	Fb-2Fx	0	0	0	0	0+0	0
BA b	0	Fb-2Fx	0	0	0	0	0	0
BC $\sqrt{2}b$	0	-Fb+ $\sqrt{2}/2Fx$	0	0	0	0	0	0
BD b	0	-1/2qx ²	0	0	0	0	0+0	0
DB b	0	1/2Fb-Fx+1/2qx ²	0	0	0	0	0	0
DC b	0	-2Fx	0	0	0	0	0+0	0
CD b	0	2Fb-2Fx	0	0	0	0	0	0
CE b	0	-Fb+Fx	0	0	0	0	0+0	0
EC b	0	Fx	0	0	0	0	0	0
FG b	-1/2x/b	-7/4Fx+1/2qx ²	-Fb/EJ	7/8Fx ² /b-1/4qx ³ /b	1/2Fx/EJ	1/4x ² /b ²	(11/48+1/4)Fb ² /EJ	1/12Xb/EJ
GF b	1/2-1/2x/b	5/4Fb-3/4Fx-1/2qx ²	Fb/EJ	5/8Fb-Fx+1/8Fx ² /b+1/4qx ³ /b	1/2Fb/EJ-1/2Fx/EJ	1/4-1/2x/b+1/4x ² /b ²		
GD b	-1+x/b	-1/2Fx	0	1/2Fx-1/2Fx ² /b	0	1-2x/b+x ² /b ²	(1/12+0)Fb ² /EJ	1/3Xb/EJ
DG b	x/b	1/2Fb-1/2Fx	0	1/2Fx-1/2Fx ² /b	0	x ² /b ²		
DH b	0	-Fb+Fx	0	0	0	0	0+0	0
HD b	0	Fx	0	0	0	0	0	0
GA b	1/2-1/2x/b	-5/4Fb+5/4Fx	0	-5/8Fb+5/4Fx-5/8Fx ² /b	0	1/4-1/2x/b+1/4x ² /b ²	(-5/24+0)Fb ² /EJ	1/12Xb/EJ
AG b	-1/2x/b	5/4Fx	0	-5/8Fx ² /b	0	1/4x ² /b ²		
	totali						17/48Fb ² /EJ	1/2Xb/EJ
	iperstatica $X=W_{GD}$						-17/24Fb	

Sviluppi di calcolo iperstatica

$$L_{FG}^{xx} = \int_0^b (1/4 x^2/b^2) 1/EJ dx = [1/12 x^3/b^2]_0^b 1/EJ$$

$$= (1/12 b) 1/EJ = 1/12 b/EJ$$

$$L_{GF}^{xx} = \int_0^b (1/4 - 1/2 x/b + 1/4 x^2/b^2) 1/EJ dx = [1/4 x - 1/4 x^2/b + 1/12 x^3/b^2]_0^b 1/EJ$$

$$= (1/4 b - 1/4 b + 1/12 b) 1/EJ = 1/12 b/EJ$$

$$L_{GD}^{xx} = \int_0^b (1 - 2 x/b + x^2/b^2) 1/EJ dx = [x - x^2/b + 1/3 x^3/b^2]_0^b 1/EJ$$

$$= (b - b + 1/3 b) 1/EJ = 1/3 b/EJ$$

$$L_{DG}^{xx} = \int_0^b (x^2/b^2) 1/EJ dx = [1/3 x^3/b^2]_0^b 1/EJ$$

$$= (1/3 b) 1/EJ = 1/3 b/EJ$$

$$L_{GA}^{xx} = \int_0^b (1/4 - 1/2 x/b + 1/4 x^2/b^2) 1/EJ dx = [1/4 x - 1/4 x^2/b + 1/12 x^3/b^2]_0^b 1/EJ$$

$$= (1/4 b - 1/4 b + 1/12 b) 1/EJ = 1/12 b/EJ$$

$$L_{AG}^{xx} = \int_0^b (1/4 x^2/b^2) 1/EJ dx = [1/12 x^3/b^2]_0^b 1/EJ$$

$$= (1/12 b) 1/EJ = 1/12 b/EJ$$

$$L_{FG}^{xo} = \int_0^b (7/8 x^2/b^2 - 1/4 x^3/b^3) Fb 1/EJ dx + \int_0^b (1/2 x/b) \theta dx$$

$$= [7/24 x^3/b^2 - 1/16 x^4/b^3]_0^b Fb 1/EJ + [1/4 x^2/b]_0^b \theta$$

$$= (7/24 b - 1/16 b) Fb 1/EJ + (1/4 b) \theta = 23/48 Fb^2/EJ$$

$$L_{GF}^{xo} = \int_0^b (5/8 - x/b + 1/8 x^2/b^2 + 1/4 x^3/b^3) Fb 1/EJ dx + \int_0^b (-1/2 + 1/2 x/b) \theta dx$$

$$= [5/8 x - 1/2 x^2/b + 1/24 x^3/b^2 + 1/16 x^4/b^3]_0^b Fb 1/EJ + [-1/2 x + 1/4 x^2/b]_0^b \theta$$

$$= (5/8 b - 1/2 b + 1/24 b + 1/16 b) Fb 1/EJ + (-1/2 b + 1/4 b) \theta = 23/48 Fb^2/EJ$$

$$L_{GD}^{xo} = \int_0^b (1/2 x/b - 1/2 x^2/b^2) Fb 1/EJ dx = [1/4 x^2/b - 1/6 x^3/b^2]_0^b Fb 1/EJ$$

$$= (1/4 b - 1/6 b) Fb 1/EJ = 1/12 Fb^2/EJ$$

$$L_{DG}^{xo} = \int_0^b (1/2 x/b - 1/2 x^2/b^2) Fb 1/EJ dx = [1/4 x^2/b - 1/6 x^3/b^2]_0^b Fb 1/EJ$$

$$= (1/4 b - 1/6 b) Fb 1/EJ = 1/12 Fb^2/EJ$$

$$L_{GA}^{xo} = \int_0^b (-5/8 + 5/4 x/b - 5/8 x^2/b^2) Fb 1/EJ dx = [-5/8 x + 5/8 x^2/b - 5/24 x^3/b^2]_0^b Fb 1/EJ$$

$$= (-5/8 b + 5/8 b - 5/24 b) Fb 1/EJ = -5/24 Fb^2/EJ$$

$$L_{AG}^{xo} = \int_0^b (-5/8 x^2/b^2) Fb 1/EJ dx = [-5/24 x^3/b^2]_0^b Fb 1/EJ$$

$$= (-5/24 b) Fb 1/EJ = -5/24 Fb^2/EJ$$

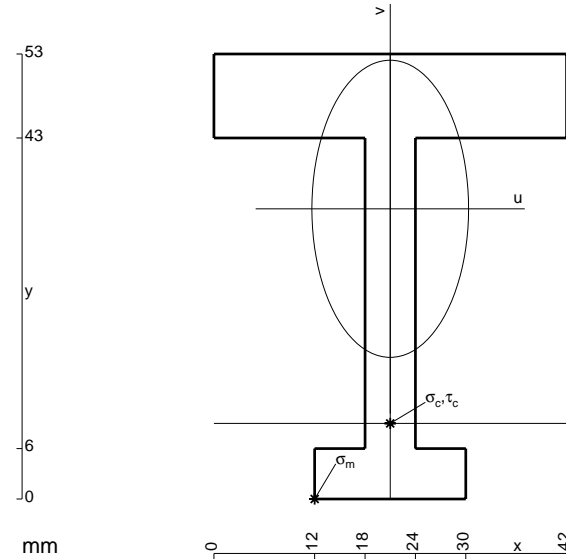

- A = 750. mm²
- J_u = 235055. mm⁴
- J_v = 65322. mm⁴
- y_g = 34.56 mm
- T_y = -2320. N
- M_x = -1624000. Nmm
- x_m = 12. mm
- u_m = -9. mm
- v_m = -34.56 mm
- σ_m = -Mv/J_u = -238.8 N/mm²
- x_c = 21. mm
- y_c = 9. mm
- v_c = -25.56 mm
- σ_c = -Mv/J_u = -176.6 N/mm²
- τ_c = 6.409 N/mm²
- σ_o = √σ²+3τ² = 177. N/mm²
- S = 3896. mm³

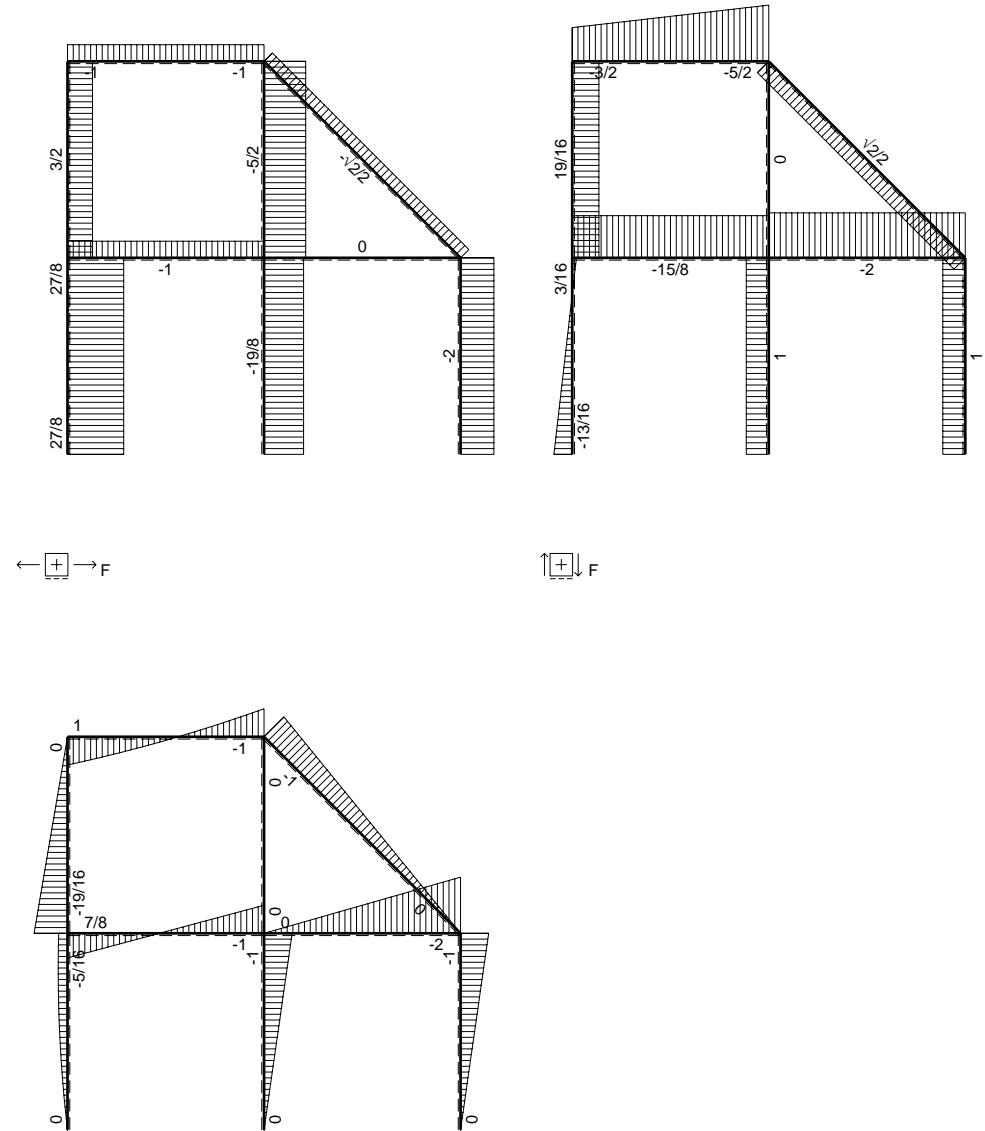
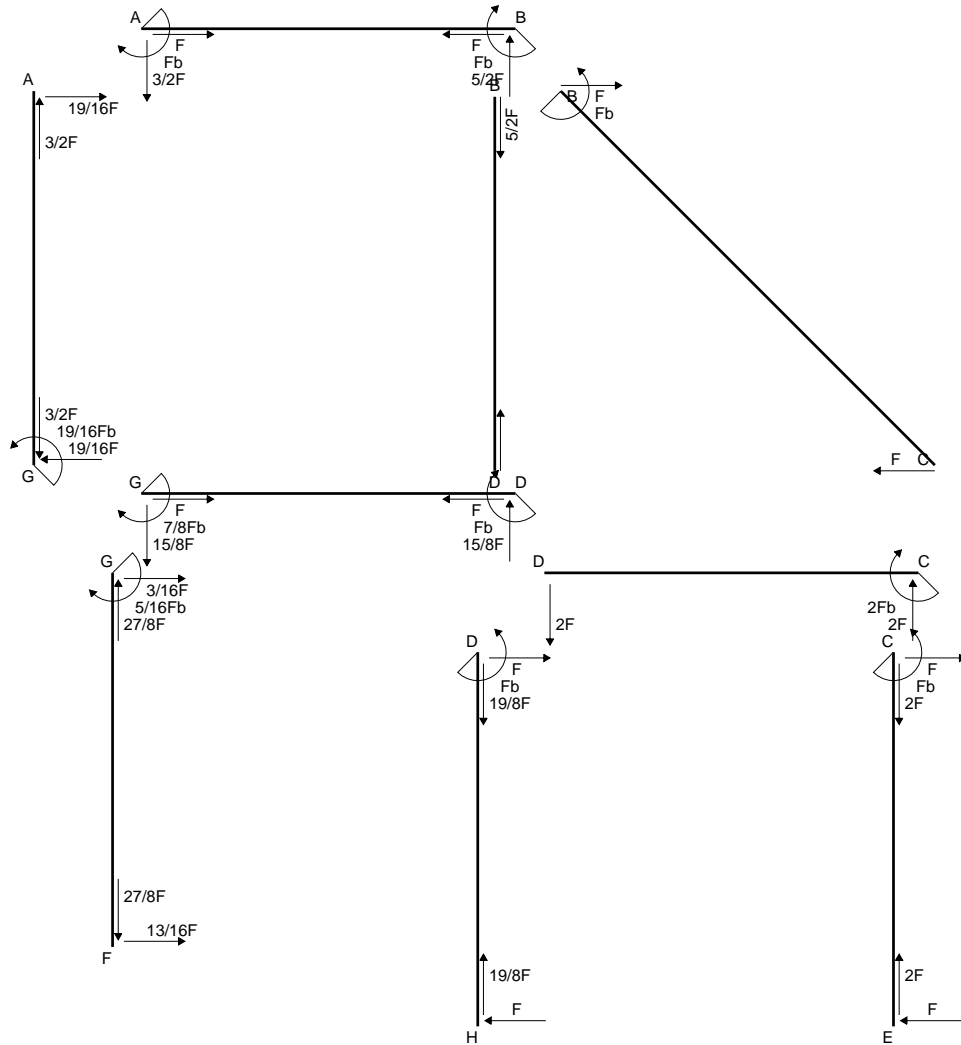

⊕ F_b

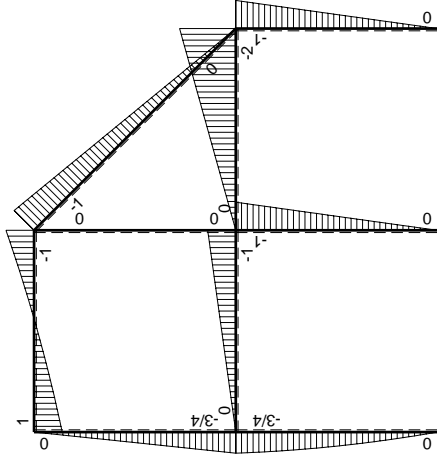
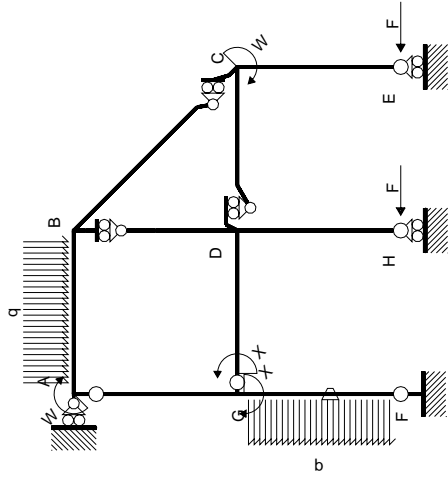

Schema di calcolo iperstatico

M_0 flessione da carichi assegnati



M_x flessione da iperstatica $X=1$

Quadro contributi PLV per iperstatica $X=W_{GD}$

→	$M_x(x)$	$M_o(x)$	θ	$M_x M_o$	$M_x \theta$	$M_x M_x$	$\int M_x(M_o/EJ+\theta)dx$	$\int x M_x M_x/EJ dx$
AB b	0	$Fb-3/2Fx-1/2qx^2$	0	0	0	0	0+0	0
BA b	0	$Fb-5/2Fx+1/2qx^2$	0	0	0	0	0	0
BC $\sqrt{2}b$	0	$-Fb+\sqrt{2}/2Fx$	0	0	0	0	0	0
BD b	0	0	0	0	0	0	0+0	0
DB b	0	0	0	0	0	0	0	0
DC b	0	$-2Fx$	0	0	0	0	0+0	0
CD b	0	$2Fb-2Fx$	0	0	0	0	0	0
CE b	0	$-Fb+Fx$	0	0	0	0	0+0	0
EC b	0	Fx	0	0	0	0	0	0
FG b	$-1/2x/b$	$-5/4Fx+1/2qx^2$	$-Fb/EJ$	$5/8Fx^2/b-1/4qx^3/b$	$1/2Fx/EJ$	$1/4x^2/b^2$	$(7/48+1/4)Fb^2/EJ$	$1/12Xb/EJ$
GF b	$1/2-1/2x/b$	$3/4Fb-1/4Fx-1/2qx^2$	Fb/EJ	$3/8Fb-1/2Fx-1/8Fx^2/b+1/4qx^3/b$	$1/2Fb/EJ-1/2Fx/EJ$	$1/4-1/2x/b+1/4x^2/b^2$		
GD b	$-1+x/b$	$-Fx$	0	$Fx-Fx^2/b$	0	$1-2x/b+x^2/b^2$	$(1/6+0)Fb^2/EJ$	$1/3Xb/EJ$
DG b	x/b	$Fb-Fx$	0	$Fx-Fx^2/b$	0	x^2/b^2		
DH b	0	$-Fb+Fx$	0	0	0	0	0+0	0
HD b	0	Fx	0	0	0	0		
GA b	$1/2-1/2x/b$	$-3/4Fb+3/4Fx$	0	$-3/8Fb+3/4Fx-3/8Fx^2/b$	0	$1/4-1/2x/b+1/4x^2/b^2$	$(-1/8+0)Fb^2/EJ$	$1/12Xb/EJ$
AG b	$-1/2x/b$	$3/4Fx$	0	$-3/8Fx^2/b$	0	$1/4x^2/b^2$		
	totali						$7/16Fb^2/EJ$	$1/2Xb/EJ$
	iperstatica $X=W_{GD}$						$-7/8Fb$	

Sviluppi di calcolo iperstatica

$$L_{FG}^{xx} = \int_0^b (1/4 x^2/b^2) 1/EJ dx = [1/12 x^3/b^2]_0^b 1/EJ$$

$$= (1/12 b) 1/EJ = 1/12 b/EJ$$

$$L_{GF}^{xx} = \int_0^b (1/4 - 1/2 x/b + 1/4 x^2/b^2) 1/EJ dx = [1/4 x - 1/4 x^2/b + 1/12 x^3/b^2]_0^b 1/EJ$$

$$= (1/4 b - 1/4 b + 1/12 b) 1/EJ = 1/12 b/EJ$$

$$L_{GD}^{xx} = \int_0^b (1 - 2 x/b + x^2/b^2) 1/EJ dx = [x - x^2/b + 1/3 x^3/b^2]_0^b 1/EJ$$

$$= (b - b + 1/3 b) 1/EJ = 1/3 b/EJ$$

$$L_{DG}^{xx} = \int_0^b (x^2/b^2) 1/EJ dx = [1/3 x^3/b^2]_0^b 1/EJ$$

$$= (1/3 b) 1/EJ = 1/3 b/EJ$$

$$L_{GA}^{xx} = \int_0^b (1/4 - 1/2 x/b + 1/4 x^2/b^2) 1/EJ dx = [1/4 x - 1/4 x^2/b + 1/12 x^3/b^2]_0^b 1/EJ$$

$$= (1/4 b - 1/4 b + 1/12 b) 1/EJ = 1/12 b/EJ$$

$$L_{AG}^{xx} = \int_0^b (1/4 x^2/b^2) 1/EJ dx = [1/12 x^3/b^2]_0^b 1/EJ$$

$$= (1/12 b) 1/EJ = 1/12 b/EJ$$

$$L_{FG}^{xo} = \int_0^b (5/8 x^2/b^2 - 1/4 x^3/b^3) Fb 1/EJ dx + \int_0^b (1/2 x/b) \theta dx$$

$$= [5/24 x^3/b^2 - 1/16 x^4/b^3]_0^b Fb 1/EJ + [1/4 x^2/b]_0^b \theta$$

$$= (5/24 b - 1/16 b) Fb 1/EJ + (1/4 b) \theta = 19/48 Fb^2/EJ$$

$$L_{GF}^{xo} = \int_0^b (3/8 - 1/2 x/b - 1/8 x^2/b^2 + 1/4 x^3/b^3) Fb 1/EJ dx + \int_0^b (-1/2 + 1/2 x/b) \theta dx$$

$$= [3/8 x - 1/4 x^2/b - 1/24 x^3/b^2 + 1/16 x^4/b^3]_0^b Fb 1/EJ + [-1/2 x + 1/4 x^2/b]_0^b \theta$$

$$= (3/8 b - 1/4 b - 1/24 b + 1/16 b) Fb 1/EJ + (-1/2 b + 1/4 b) \theta = 19/48 Fb^2/EJ$$

$$L_{GD}^{xo} = \int_0^b (x/b - x^2/b^2) Fb 1/EJ dx = [1/2 x^2/b - 1/3 x^3/b^2]_0^b Fb 1/EJ$$

$$= (1/2 b - 1/3 b) Fb 1/EJ = 1/6 Fb^2/EJ$$

$$L_{DG}^{xo} = \int_0^b (x/b - x^2/b^2) Fb 1/EJ dx = [1/2 x^2/b - 1/3 x^3/b^2]_0^b Fb 1/EJ$$

$$= (1/2 b - 1/3 b) Fb 1/EJ = 1/6 Fb^2/EJ$$

$$L_{GA}^{xo} = \int_0^b (-3/8 + 3/4 x/b - 3/8 x^2/b^2) Fb 1/EJ dx = [-3/8 x + 3/8 x^2/b - 1/8 x^3/b^2]_0^b Fb 1/EJ$$

$$= (-3/8 b + 3/8 b - 1/8 b) Fb 1/EJ = -1/8 Fb^2/EJ$$

$$L_{AG}^{xo} = \int_0^b (-3/8 x^2/b^2) Fb 1/EJ dx = [-1/8 x^3/b^2]_0^b Fb 1/EJ$$

$$= (-1/8 b) Fb 1/EJ = -1/8 Fb^2/EJ$$

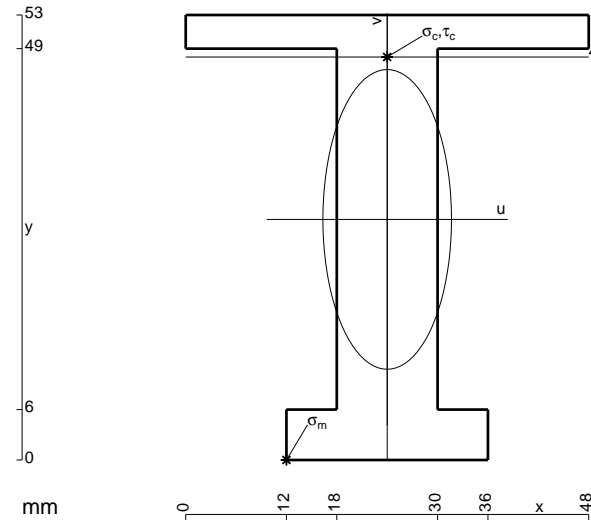

$$A = 852. \text{ mm}^2$$

$$J_u = 271527. \text{ mm}^4$$

$$J_v = 49968. \text{ mm}^4$$

$$y_g = 28.65 \text{ mm}$$

$$T_y = -2520. \text{ N}$$

$$M_x = -1890000. \text{ Nmm}$$

$$x_m = 12. \text{ mm}$$

$$u_m = -12. \text{ mm}$$

$$v_m = -28.65 \text{ mm}$$

$$\sigma_m = -Mv/J_u = -199.5 \text{ N/mm}^2$$

$$x_c = 24. \text{ mm}$$

$$y_c = 48. \text{ mm}$$

$$v_c = 19.35 \text{ mm}$$

$$\sigma_c = -Mv/J_u = 134.7 \text{ N/mm}^2$$

$$\tau_c = 3.502 \text{ N/mm}^2$$

$$\sigma_q = \sqrt{\sigma^2 + 3\tau^2} = 134.8 \text{ N/mm}^2$$

$$S = 4528. \text{ mm}^3$$

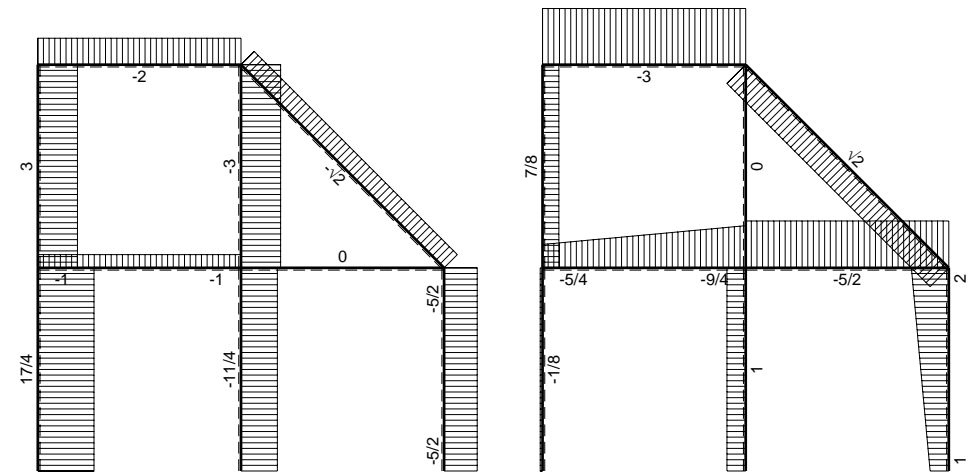
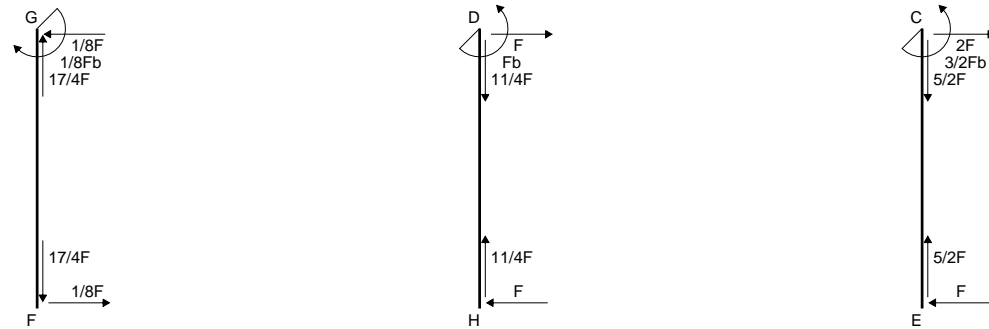
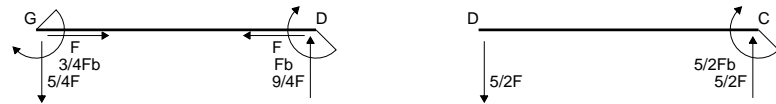
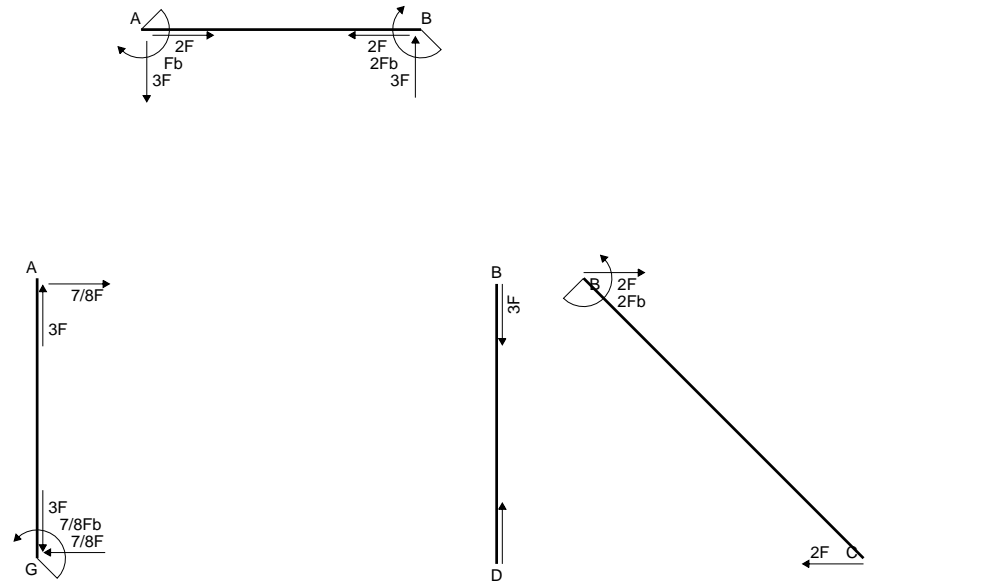

← ⊕ → F

↑ ⊕ ↓ F

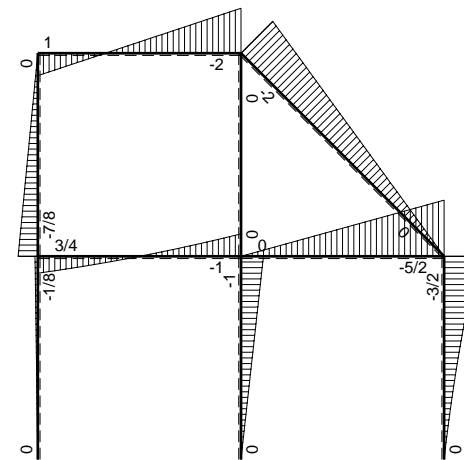

⊕ ⊖ F_b

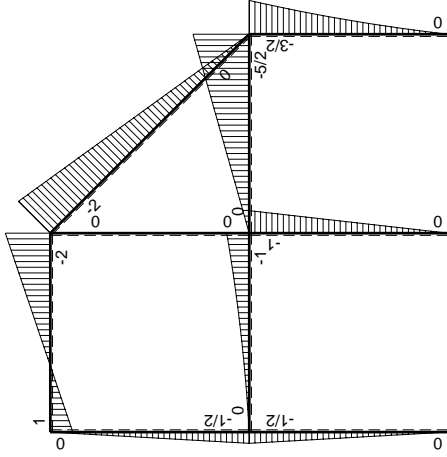
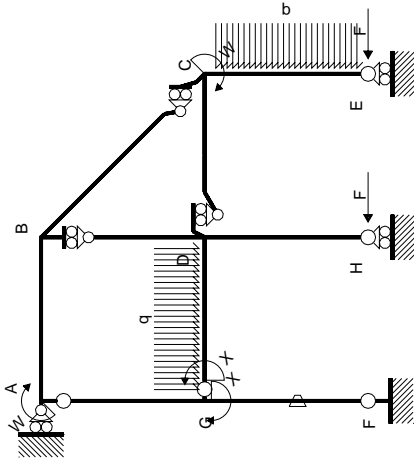

Schema di calcolo iperstatico

M_0 flessione da carichi assegnati

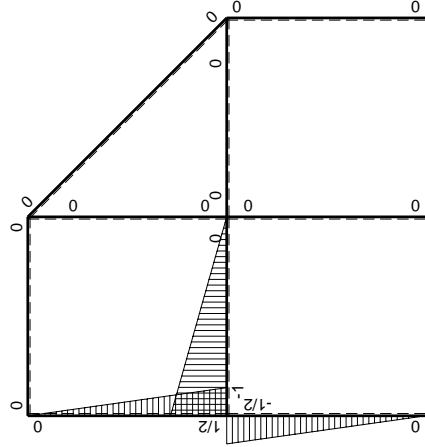

M_X flessione da iperstatica $X=1$

Quadro contributi PLV per iperstatica $X=W_{GD}$

→	$M_x(x)$	$M_o(x)$	θ	$M_x M_o$	$M_x \theta$	$M_x M_x$	$\int M_x(M_o/EJ+\theta)dx$	$\int X M_x M_x/EJ dx$	
AB b	0	Fb-3Fx	0	0	0	0	0+0	0	
BA b	0	2Fb-3Fx	0	0	0	0			
BC $\sqrt{2}b$	0	-2Fb+ $\sqrt{2}Fx$	0	0	0	0	0	0	
BD b	0	0	0	0	0	0	0+0	0	
DB b	0	0	0	0	0	0			
DC b	0	-5/2Fx	0	0	0	0	0+0	0	
CD b	0	5/2Fb-5/2Fx	0	0	0	0			
CE b	0	-3/2Fb+2Fx-1/2qx ²	0	0	0	0	0+0	0	
EC b	0	Fx+1/2qx ²	0	0	0	0			
FG b	-1/2x/b	-1/2Fx	-Fb/EJ	1/4Fx ² /b	1/2Fx/EJ	1/4x ² /b ²	(1/12+1/4)Fb ² /EJ	1/12Xb/EJ	
GF b	1/2-1/2x/b	1/2Fb-1/2Fx	Fb/EJ	1/4Fb-1/2Fx+1/4Fx ² /b	1/2Fb/EJ-1/2Fx/EJ	1/4-1/2x/b+1/4x ² /b ²			
GD b	-1+x/b	-1/2Fx-1/2qx ²	0	1/2Fx-1/2qx ³ /b	0	1-2x/b+x ² /b ²	(1/8+0)Fb ² /EJ	1/3Xb/EJ	
DG b	x/b	Fb-3/2Fx+1/2qx ²	0	Fx-3/2Fx ² /b+1/2qx ³ /b	0	x ² /b ²			
DH b	0	-Fb+Fx	0	0	0	0	0+0	0	
HD b	0	Fx	0	0	0	0			
GA b	1/2-1/2x/b	-1/2Fb+1/2Fx	0	-1/4Fb+1/2Fx-1/4Fx ² /b	0	1/4-1/2x/b+1/4x ² /b ²	(-1/12+0)Fb ² /EJ	1/12Xb/EJ	
AG b	-1/2x/b	1/2Fx	0	-1/4Fx ² /b	0	1/4x ² /b ²			
	totali							3/8Fb ² /EJ	1/2Xb/EJ
	iperstatica $X=W_{GD}$							-3/4Fb	

Sviluppi di calcolo iperstatica

$$L_{FG}^{xx} = \int_0^b (1/4 x^2/b^2) 1/EJ dx = [1/12 x^3/b^2]_0^b 1/EJ$$

$$= (1/12 b) 1/EJ = 1/12 b/EJ$$

$$L_{GF}^{xx} = \int_0^b (1/4 - 1/2 x/b + 1/4 x^2/b^2) 1/EJ dx = [1/4 x - 1/4 x^2/b + 1/12 x^3/b^2]_0^b 1/EJ$$

$$= (1/4 b - 1/4 b + 1/12 b) 1/EJ = 1/12 b/EJ$$

$$L_{GD}^{xx} = \int_0^b (1 - 2 x/b + x^2/b^2) 1/EJ dx = [x - x^2/b + 1/3 x^3/b^2]_0^b 1/EJ$$

$$= (b - b + 1/3 b) 1/EJ = 1/3 b/EJ$$

$$L_{DG}^{xx} = \int_0^b (x^2/b^2) 1/EJ dx = [1/3 x^3/b^2]_0^b 1/EJ$$

$$= (1/3 b) 1/EJ = 1/3 b/EJ$$

$$L_{GA}^{xx} = \int_0^b (1/4 - 1/2 x/b + 1/4 x^2/b^2) 1/EJ dx = [1/4 x - 1/4 x^2/b + 1/12 x^3/b^2]_0^b 1/EJ$$

$$= (1/4 b - 1/4 b + 1/12 b) 1/EJ = 1/12 b/EJ$$

$$L_{AG}^{xx} = \int_0^b (1/4 x^2/b^2) 1/EJ dx = [1/12 x^3/b^2]_0^b 1/EJ$$

$$= (1/12 b) 1/EJ = 1/12 b/EJ$$

$$L_{FG}^{xo} = \int_0^b (1/4 x^2/b^2) Fb 1/EJ dx + \int_0^b (1/2 x/b) \theta dx = [1/12 x^3/b^2]_0^b Fb 1/EJ + [1/4 x^2/b]_0^b \theta$$

$$= (1/12 b) Fb 1/EJ + (1/4 b) \theta = 1/3 Fb^2/EJ$$

$$L_{GF}^{xo} = \int_0^b (1/4 - 1/2 x/b + 1/4 x^2/b^2) Fb 1/EJ dx + \int_0^b (-1/2 + 1/2 x/b) \theta dx$$

$$= [1/4 x - 1/4 x^2/b + 1/12 x^3/b^2]_0^b Fb 1/EJ + [-1/2 x + 1/4 x^2/b]_0^b \theta$$

$$= (1/4 b - 1/4 b + 1/12 b) Fb 1/EJ + (-1/2 b + 1/4 b) \theta = 1/3 Fb^2/EJ$$

$$L_{GD}^{xo} = \int_0^b (1/2 x/b - 1/2 x^3/b^3) Fb 1/EJ dx = [1/4 x^2/b - 1/8 x^4/b^3]_0^b Fb 1/EJ$$

$$= (1/4 b - 1/8 b) Fb 1/EJ = 1/8 Fb^2/EJ$$

$$L_{DG}^{xo} = \int_0^b (x/b - 3/2 x^2/b^2 + 1/2 x^3/b^3) Fb 1/EJ dx = [1/2 x^2/b - 1/2 x^3/b^2 + 1/8 x^4/b^3]_0^b Fb 1/EJ$$

$$= (1/2 b - 1/2 b + 1/8 b) Fb 1/EJ = 1/8 Fb^2/EJ$$

$$L_{GA}^{xo} = \int_0^b (-1/4 + 1/2 x/b - 1/4 x^2/b^2) Fb 1/EJ dx = [-1/4 x + 1/4 x^2/b - 1/12 x^3/b^2]_0^b Fb 1/EJ$$

$$= (-1/4 b + 1/4 b - 1/12 b) Fb 1/EJ = -1/12 Fb^2/EJ$$

$$L_{AG}^{xo} = \int_0^b (-1/4 x^2/b^2) Fb 1/EJ dx = [-1/12 x^3/b^2]_0^b Fb 1/EJ$$

$$= (-1/12 b) Fb 1/EJ = -1/12 Fb^2/EJ$$

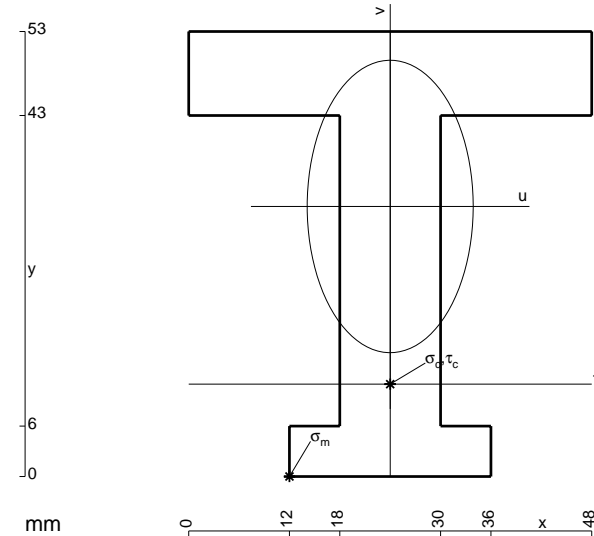

$$A = 1068. \text{ mm}^2$$

$$J_u = 324016. \text{ mm}^4$$

$$J_v = 104400. \text{ mm}^4$$

$$y_g = 32.16 \text{ mm}$$

$$T_y = -2625. \text{ N}$$

$$M_x = -2100000. \text{ Nmm}$$

$$x_m = 12. \text{ mm}$$

$$u_m = -12. \text{ mm}$$

$$v_m = -32.16 \text{ mm}$$

$$\sigma_m = -Mv/J_u = -208.5 \text{ N/mm}^2$$

$$x_c = 24. \text{ mm}$$

$$y_c = 11. \text{ mm}$$

$$v_c = -21.16 \text{ mm}$$

$$\sigma_c = -Mv/J_u = -137.2 \text{ N/mm}^2$$

$$\tau_c = 3.794 \text{ N/mm}^2$$

$$\sigma_o = \sqrt{\sigma^2 + 3\tau^2} = 137.3 \text{ N/mm}^2$$

$$S = 5619. \text{ mm}^3$$

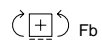
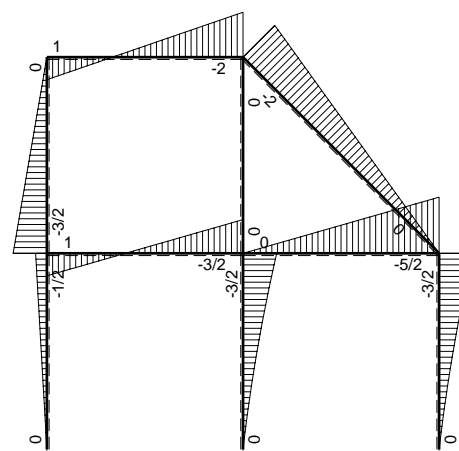
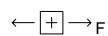
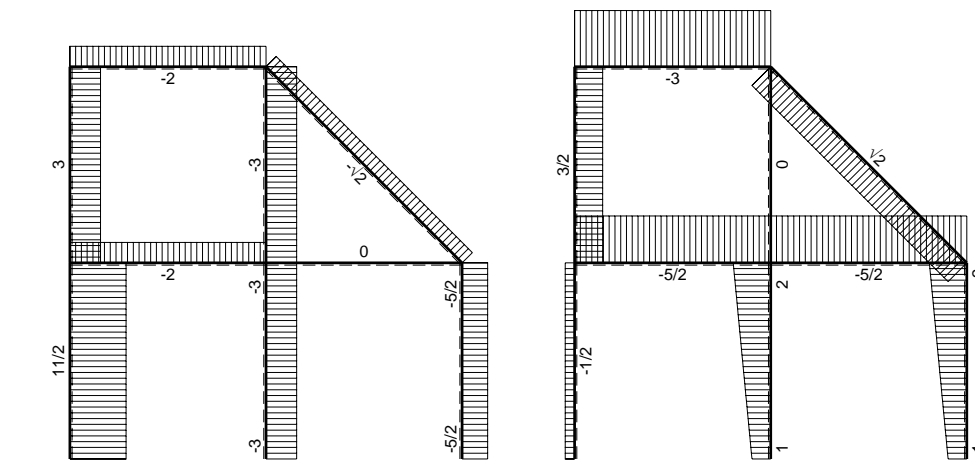
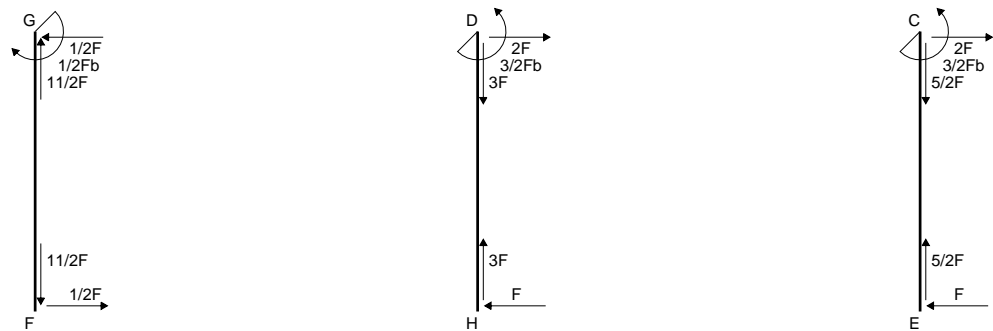
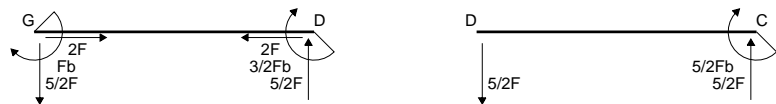
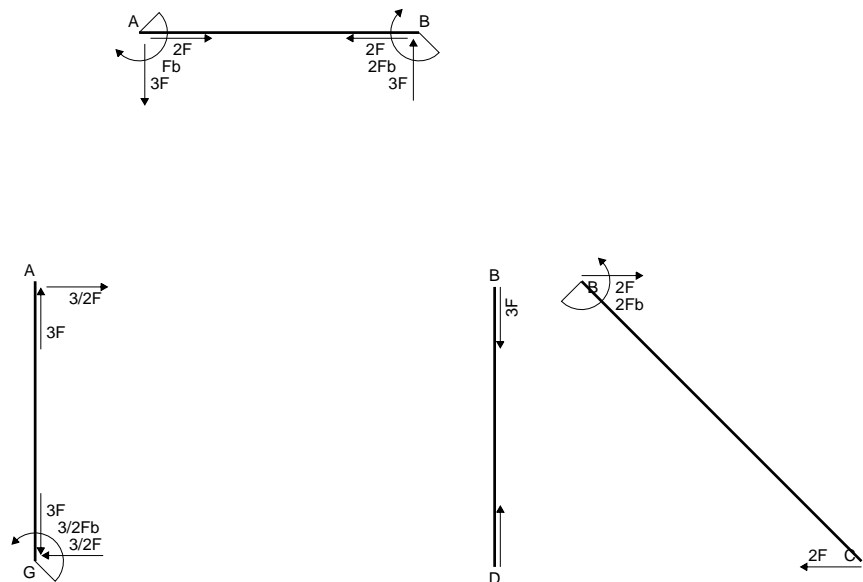

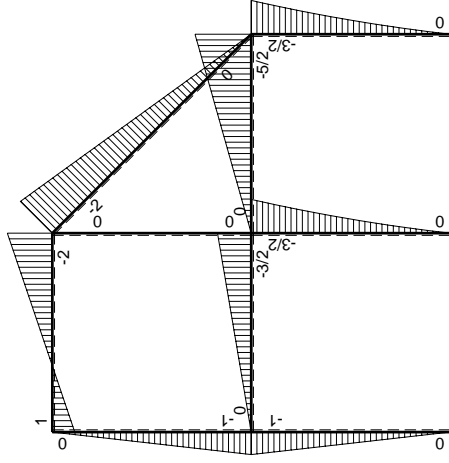
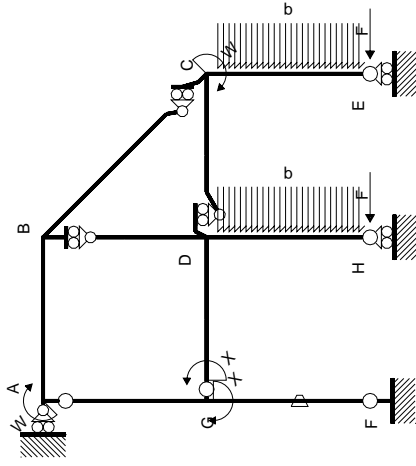

Schema di calcolo iperstatico

M_0 flessione da carichi assegnati

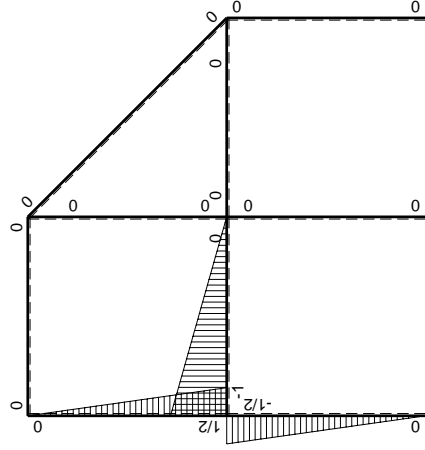

M_X flessione da iperstatica $X=1$

Quadro contributi PLV per iperstatica $X=W_{GD}$

→	$M_x(x)$	$M_o(x)$	θ	$M_x M_o$	$M_x \theta$	$M_x M_x$	$\int M_x(M_o/EJ+\theta)dx$	$\int X M_x M_x / EJ dx$
AB b	0	$Fb-3Fx$	0	0	0	0	0+0	0
BA b	0	$2Fb-3Fx$	0	0	0	0	0	0
BC $\sqrt{2}b$	0	$-2Fb+\sqrt{2}Fx$	0	0	0	0	0	0
BD b	0	0	0	0	0	0	0+0	0
DB b	0	0	0	0	0	0	0	0
DC b	0	$-5/2Fx$	0	0	0	0	0+0	0
CD b	0	$5/2Fb-5/2Fx$	0	0	0	0	0	0
CE b	0	$-3/2Fb+2Fx-1/2qx^2$	0	0	0	0	0+0	0
EC b	0	$Fx+1/2qx^2$	0	0	0	0	0	0
FG b	$-1/2x/b$	$-Fx$	$-Fb/EJ$	$1/2Fx^2/b$	$1/2Fx/EJ$	$1/4x^2/b^2$	$(1/6+1/4)Fb^2/EJ$	$1/12Xb/EJ$
GF b	$1/2-1/2x/b$	$Fb-Fx$	Fb/EJ	$1/2Fb-Fx+1/2Fx^2/b$	$1/2Fb/EJ-1/2Fx/EJ$	$1/4-1/2x/b+1/4x^2/b^2$		
GD b	$-1+x/b$	$-3/2Fx$	0	$3/2Fx-3/2Fx^2/b$	0	$1-2x/b+x^2/b^2$	$(1/4+0)Fb^2/EJ$	$1/3Xb/EJ$
DG b	x/b	$3/2Fb-3/2Fx$	0	$3/2Fx-3/2Fx^2/b$	0	x^2/b^2		
DH b	0	$-3/2Fb+2Fx-1/2qx^2$	0	0	0	0	0+0	0
HD b	0	$Fx+1/2qx^2$	0	0	0	0	0	0
GA b	$1/2-1/2x/b$	$-Fb+Fx$	0	$-1/2Fb+Fx-1/2Fx^2/b$	0	$1/4-1/2x/b+1/4x^2/b^2$	$(-1/6+0)Fb^2/EJ$	$1/12Xb/EJ$
AG b	$-1/2x/b$	Fx	0	$-1/2Fx^2/b$	0	$1/4x^2/b^2$		
	totali						$1/2Fb^2/EJ$	$1/2Xb/EJ$
	iperstatica $X=W_{GD}$						$-Fb$	

Sviluppi di calcolo iperstatica

$$L_{FG}^{xx} = \int_0^b (1/4 x^2/b^2) 1/EJ dx = [1/12 x^3/b^2]_0^b 1/EJ$$

$$= (1/12 b) 1/EJ = 1/12 b/EJ$$

$$L_{GF}^{xx} = \int_0^b (1/4 - 1/2 x/b + 1/4 x^2/b^2) 1/EJ dx = [1/4 x - 1/4 x^2/b + 1/12 x^3/b^2]_0^b 1/EJ$$

$$= (1/4 b - 1/4 b + 1/12 b) 1/EJ = 1/12 b/EJ$$

$$L_{GD}^{xx} = \int_0^b (1 - 2 x/b + x^2/b^2) 1/EJ dx = [x - x^2/b + 1/3 x^3/b^2]_0^b 1/EJ$$

$$= (b - b + 1/3 b) 1/EJ = 1/3 b/EJ$$

$$L_{DG}^{xx} = \int_0^b (x^2/b^2) 1/EJ dx = [1/3 x^3/b^2]_0^b 1/EJ$$

$$= (1/3 b) 1/EJ = 1/3 b/EJ$$

$$L_{GA}^{xx} = \int_0^b (1/4 - 1/2 x/b + 1/4 x^2/b^2) 1/EJ dx = [1/4 x - 1/4 x^2/b + 1/12 x^3/b^2]_0^b 1/EJ$$

$$= (1/4 b - 1/4 b + 1/12 b) 1/EJ = 1/12 b/EJ$$

$$L_{AG}^{xx} = \int_0^b (1/4 x^2/b^2) 1/EJ dx = [1/12 x^3/b^2]_0^b 1/EJ$$

$$= (1/12 b) 1/EJ = 1/12 b/EJ$$

$$L_{FG}^{xo} = \int_0^b (1/2 x^2/b^2) Fb 1/EJ dx + \int_0^b (1/2 x/b) \theta dx = [1/6 x^3/b^2]_0^b Fb 1/EJ + [1/4 x^2/b]_0^b \theta$$

$$= (1/6 b) Fb 1/EJ + (1/4 b) \theta = 5/12 Fb^2/EJ$$

$$L_{GF}^{xo} = \int_0^b (1/2 - x/b + 1/2 x^2/b^2) Fb 1/EJ dx + \int_0^b (-1/2 + 1/2 x/b) \theta dx$$

$$= [1/2 x - 1/2 x^2/b + 1/6 x^3/b^2]_0^b Fb 1/EJ + [-1/2 x + 1/4 x^2/b]_0^b \theta$$

$$= (1/2 b - 1/2 b + 1/6 b) Fb 1/EJ + (-1/2 b + 1/4 b) \theta = 5/12 Fb^2/EJ$$

$$L_{GD}^{xo} = \int_0^b (3/2 x/b - 3/2 x^2/b^2) Fb 1/EJ dx = [3/4 x^2/b - 1/2 x^3/b^2]_0^b Fb 1/EJ$$

$$= (3/4 b - 1/2 b) Fb 1/EJ = 1/4 Fb^2/EJ$$

$$L_{DG}^{xo} = \int_0^b (3/2 x/b - 3/2 x^2/b^2) Fb 1/EJ dx = [3/4 x^2/b - 1/2 x^3/b^2]_0^b Fb 1/EJ$$

$$= (3/4 b - 1/2 b) Fb 1/EJ = 1/4 Fb^2/EJ$$

$$L_{GA}^{xo} = \int_0^b (-1/2 + x/b - 1/2 x^2/b^2) Fb 1/EJ dx = [-1/2 x + 1/2 x^2/b - 1/6 x^3/b^2]_0^b Fb 1/EJ$$

$$= (-1/2 b + 1/2 b - 1/6 b) Fb 1/EJ = -1/6 Fb^2/EJ$$

$$L_{AG}^{xo} = \int_0^b (-1/2 x^2/b^2) Fb 1/EJ dx = [-1/6 x^3/b^2]_0^b Fb 1/EJ$$

$$= (-1/6 b) Fb 1/EJ = -1/6 Fb^2/EJ$$

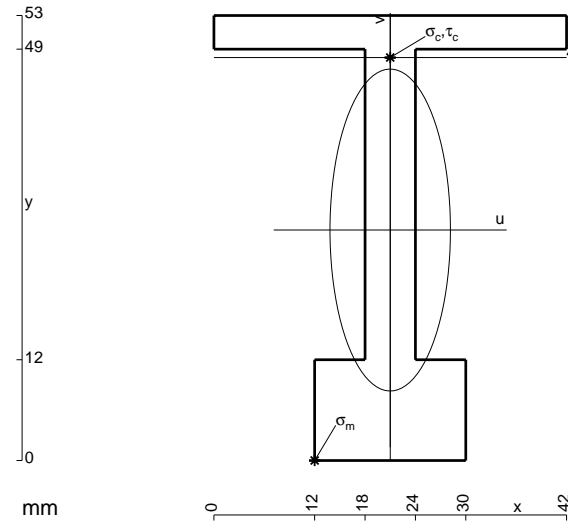

$$A = 606. \text{ mm}^2$$

$$J_u = 222763. \text{ mm}^4$$

$$J_v = 31194. \text{ mm}^4$$

$$y_g = 27.45 \text{ mm}$$

$$T_y = -2100. \text{ N}$$

$$M_x = -1785000. \text{ Nmm}$$

$$x_m = 12. \text{ mm}$$

$$u_m = -9. \text{ mm}$$

$$v_m = -27.45 \text{ mm}$$

$$\sigma_m = -Mv/J_u = -220. \text{ N/mm}^2$$

$$x_c = 21. \text{ mm}$$

$$y_c = 48. \text{ mm}$$

$$v_c = 20.55 \text{ mm}$$

$$\sigma_c = -Mv/J_u = 164.7 \text{ N/mm}^2$$

$$\tau_c = 6.415 \text{ N/mm}^2$$

$$\sigma_q = \sqrt{\sigma^2 + 3\tau^2} = 165. \text{ N/mm}^2$$

$$S = 4083. \text{ mm}^3$$

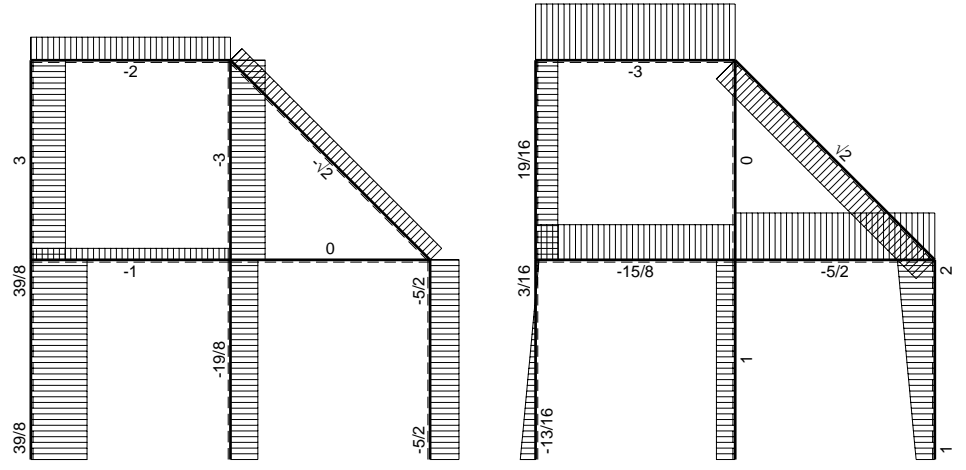
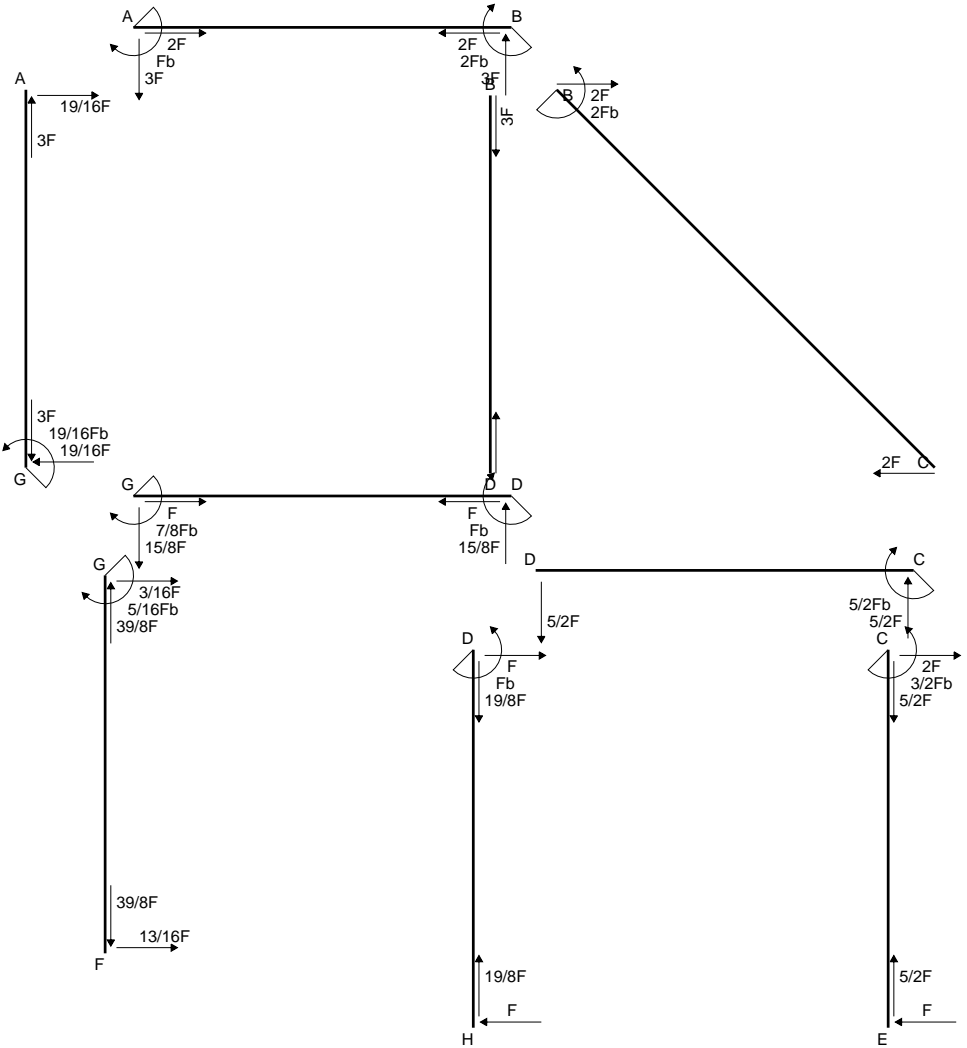

← (+) → F

↑ (+) ↓ Fb

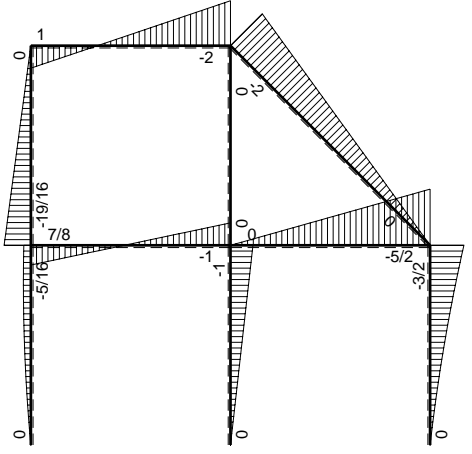

⊕ (+) ⊖ Fb

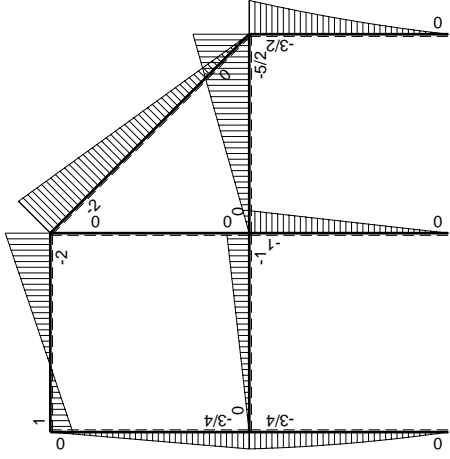
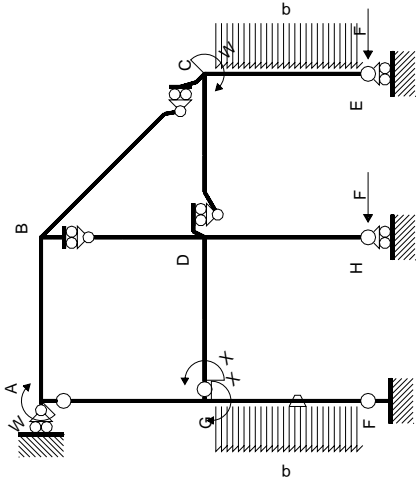

Schema di calcolo iperstatico

M_0 flessione da carichi assegnati

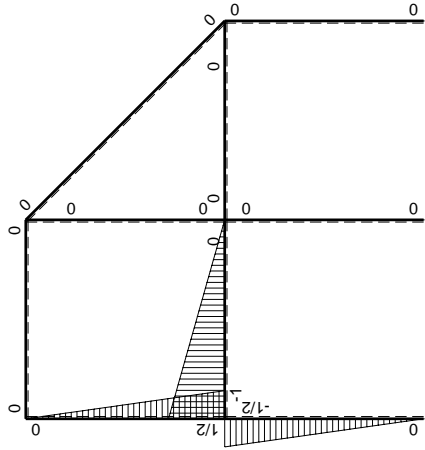

M_x flessione da iperstatica $X=1$

Quadro contributi PLV per iperstatica $X=W_{GD}$

→	$M_x(x)$	$M_o(x)$	θ	$M_x M_o$	$M_x \theta$	$M_x M_x$	$\int M_x(M_o/EJ+\theta)dx$	$\int x M_x M_x/EJ dx$
AB b	0	$Fb-3Fx$	0	0	0	0	0+0	0
BA b	0	$2Fb-3Fx$	0	0	0	0		
BC $\sqrt{2}b$	0	$-2Fb+\sqrt{2}Fx$	0	0	0	0	0	0
BD b	0	0	0	0	0	0	0+0	0
DB b	0	0	0	0	0	0		
DC b	0	$-5/2Fx$	0	0	0	0	0+0	0
CD b	0	$5/2Fb-5/2Fx$	0	0	0	0		
CE b	0	$-3/2Fb+2Fx-1/2qx^2$	0	0	0	0	0+0	0
EC b	0	$Fx+1/2qx^2$	0	0	0	0		
FG b	$-1/2x/b$	$-5/4Fx+1/2qx^2$	$-Fb/EJ$	$5/8Fx^2/b-1/4qx^3/b$	$1/2Fx/EJ$	$1/4x^2/b^2$	$(7/48+1/4)Fb^2/EJ$	$1/12Xb/EJ$
GF b	$1/2-1/2x/b$	$3/4Fb-1/4Fx-1/2qx^2$	Fb/EJ	$3/8Fb-1/2Fx-1/8Fx^2/b+1/4qx^3/b$	$1/2Fb/EJ-1/2Fx/EJ$	$1/4-1/2x/b+1/4x^2/b^2$		
GD b	$-1+x/b$	$-Fx$	0	$Fx-Fx^2/b$	0	$1-2x/b+x^2/b^2$	$(1/6+0)Fb^2/EJ$	$1/3Xb/EJ$
DG b	x/b	$Fb-Fx$	0	$Fx-Fx^2/b$	0	x^2/b^2		
DH b	0	$-Fb+Fx$	0	0	0	0	0+0	0
HD b	0	Fx	0	0	0	0		
GA b	$1/2-1/2x/b$	$-3/4Fb+3/4Fx$	0	$-3/8Fb+3/4Fx-3/8Fx^2/b$	0	$1/4-1/2x/b+1/4x^2/b^2$	$(-1/8+0)Fb^2/EJ$	$1/12Xb/EJ$
AG b	$-1/2x/b$	$3/4Fx$	0	$-3/8Fx^2/b$	0	$1/4x^2/b^2$		
	totali						$7/16Fb^2/EJ$	$1/2Xb/EJ$
	iperstatica $X=W_{GD}$						$-7/8Fb$	

Sviluppi di calcolo iperstatica

$$L_{FG}^{xx} = \int_0^b (1/4 x^2/b^2) 1/EJ dx = [1/12 x^3/b^2]_0^b 1/EJ$$

$$= (1/12 b) 1/EJ = 1/12 b/EJ$$

$$L_{GF}^{xx} = \int_0^b (1/4 - 1/2 x/b + 1/4 x^2/b^2) 1/EJ dx = [1/4 x - 1/4 x^2/b + 1/12 x^3/b^2]_0^b 1/EJ$$

$$= (1/4 b - 1/4 b + 1/12 b) 1/EJ = 1/12 b/EJ$$

$$L_{GD}^{xx} = \int_0^b (1 - 2 x/b + x^2/b^2) 1/EJ dx = [x - x^2/b + 1/3 x^3/b^2]_0^b 1/EJ$$

$$= (b - b + 1/3 b) 1/EJ = 1/3 b/EJ$$

$$L_{DG}^{xx} = \int_0^b (x^2/b^2) 1/EJ dx = [1/3 x^3/b^2]_0^b 1/EJ$$

$$= (1/3 b) 1/EJ = 1/3 b/EJ$$

$$L_{GA}^{xx} = \int_0^b (1/4 - 1/2 x/b + 1/4 x^2/b^2) 1/EJ dx = [1/4 x - 1/4 x^2/b + 1/12 x^3/b^2]_0^b 1/EJ$$

$$= (1/4 b - 1/4 b + 1/12 b) 1/EJ = 1/12 b/EJ$$

$$L_{AG}^{xx} = \int_0^b (1/4 x^2/b^2) 1/EJ dx = [1/12 x^3/b^2]_0^b 1/EJ$$

$$= (1/12 b) 1/EJ = 1/12 b/EJ$$

$$L_{FG}^{xo} = \int_0^b (5/8 x^2/b^2 - 1/4 x^3/b^3) Fb 1/EJ dx + \int_0^b (1/2 x/b) \theta dx$$

$$= [5/24 x^3/b^2 - 1/16 x^4/b^3]_0^b Fb 1/EJ + [1/4 x^2/b]_0^b \theta$$

$$= (5/24 b - 1/16 b) Fb 1/EJ + (1/4 b) \theta = 19/48 Fb^2/EJ$$

$$L_{GF}^{xo} = \int_0^b (3/8 - 1/2 x/b - 1/8 x^2/b^2 + 1/4 x^3/b^3) Fb 1/EJ dx + \int_0^b (-1/2 + 1/2 x/b) \theta dx$$

$$= [3/8 x - 1/4 x^2/b - 1/24 x^3/b^2 + 1/16 x^4/b^3]_0^b Fb 1/EJ + [-1/2 x + 1/4 x^2/b]_0^b \theta$$

$$= (3/8 b - 1/4 b - 1/24 b + 1/16 b) Fb 1/EJ + (-1/2 b + 1/4 b) \theta = 19/48 Fb^2/EJ$$

$$L_{GD}^{xo} = \int_0^b (x/b - x^2/b^2) Fb 1/EJ dx = [1/2 x^2/b - 1/3 x^3/b^2]_0^b Fb 1/EJ$$

$$= (1/2 b - 1/3 b) Fb 1/EJ = 1/6 Fb^2/EJ$$

$$L_{DG}^{xo} = \int_0^b (x/b - x^2/b^2) Fb 1/EJ dx = [1/2 x^2/b - 1/3 x^3/b^2]_0^b Fb 1/EJ$$

$$= (1/2 b - 1/3 b) Fb 1/EJ = 1/6 Fb^2/EJ$$

$$L_{GA}^{xo} = \int_0^b (-3/8 + 3/4 x/b - 3/8 x^2/b^2) Fb 1/EJ dx = [-3/8 x + 3/8 x^2/b - 1/8 x^3/b^2]_0^b Fb 1/EJ$$

$$= (-3/8 b + 3/8 b - 1/8 b) Fb 1/EJ = -1/8 Fb^2/EJ$$

$$L_{AG}^{xo} = \int_0^b (-3/8 x^2/b^2) Fb 1/EJ dx = [-1/8 x^3/b^2]_0^b Fb 1/EJ$$

$$= (-1/8 b) Fb 1/EJ = -1/8 Fb^2/EJ$$

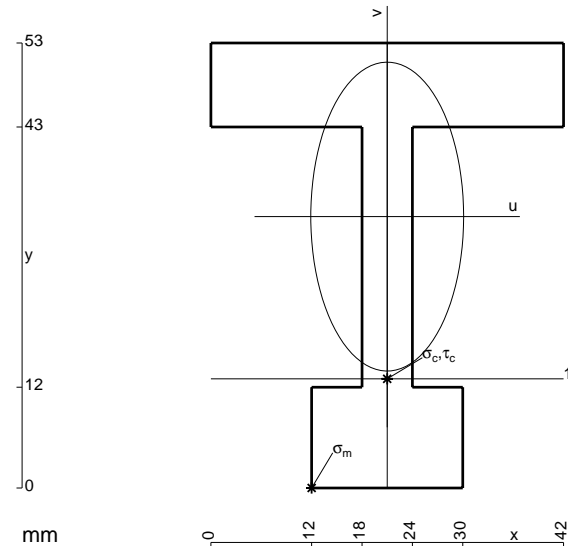

$$A = 822. \text{ mm}^2$$

$$J_u = 278203. \text{ mm}^4$$

$$J_v = 68130. \text{ mm}^4$$

$$y_g = 32.32 \text{ mm}$$

$$T_y = -2175. \text{ N}$$

$$M_x = -1957500. \text{ Nmm}$$

$$x_m = 12. \text{ mm}$$

$$u_m = -9. \text{ mm}$$

$$v_m = -32.32 \text{ mm}$$

$$\sigma_m = -Mv/J_u = -227.4 \text{ N/mm}^2$$

$$x_c = 21. \text{ mm}$$

$$y_c = 13. \text{ mm}$$

$$v_c = -19.32 \text{ mm}$$

$$\sigma_c = -Mv/J_u = -136. \text{ N/mm}^2$$

$$\tau_c = 7.564 \text{ N/mm}^2$$

$$\sigma_q = \sqrt{\sigma^2 + 3\tau^2} = 136.6 \text{ N/mm}^2$$

$$S = 5805. \text{ mm}^3$$

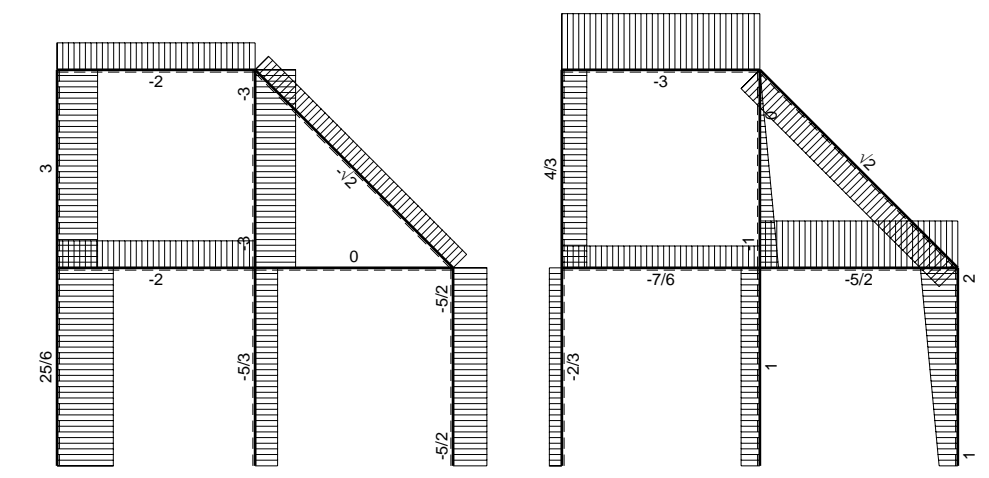
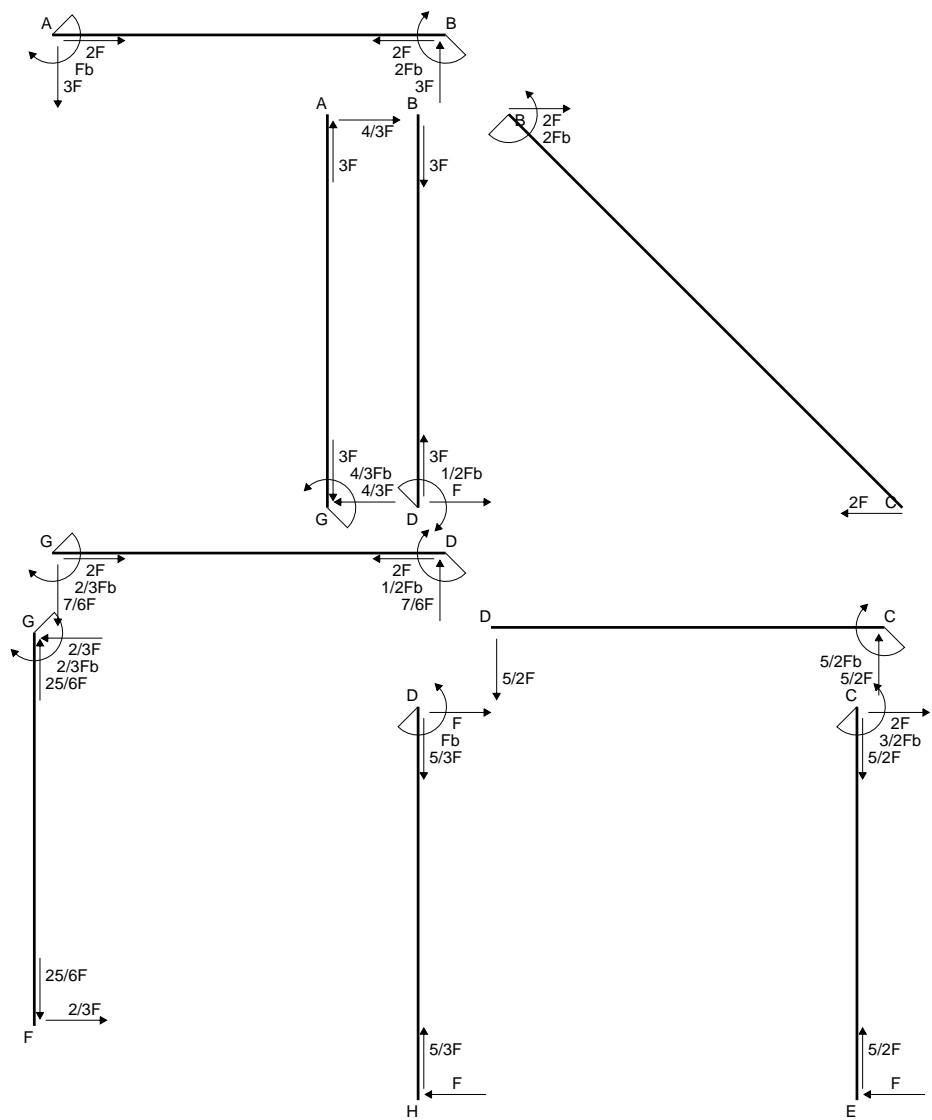

← ⊕ → F

↑ ⊕ ↓ F

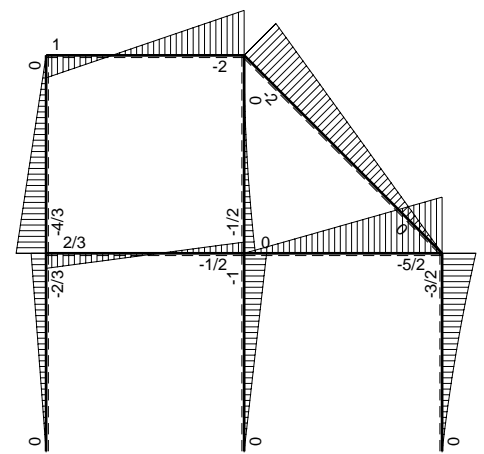

⊕ ⊖ Fb

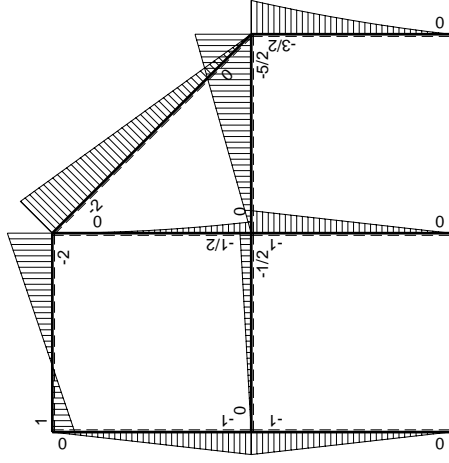
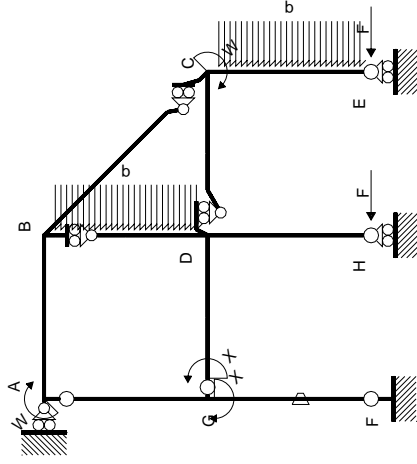

Schema di calcolo iperstatico

M_0 flessione da carichi assegnati

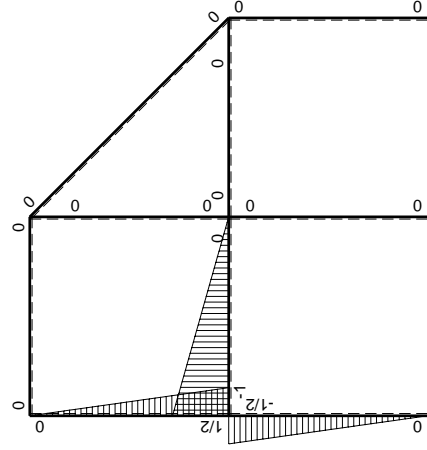

M_1 flessione da iperstatica $X=1$

Quadro contributi PLV per iperstatica $X=W_{GD}$

→	$M_x(x)$	$M_o(x)$	θ	$M_x M_o$	$M_x \theta$	$M_x M_x$	$\int M_x(M_o/EJ+\theta)dx$	$\int X M_x M_x/EJ dx$	
AB b	0	$Fb-3Fx$	0	0	0	0	0+0	0	
BA b	0	$2Fb-3Fx$	0	0	0	0	0	0	
BC $\sqrt{2}b$	0	$-2Fb+\sqrt{2}Fx$	0	0	0	0	0	0	
BD b	0	$-1/2qx^2$	0	0	0	0	0+0	0	
DB b	0	$1/2Fb-Fx+1/2qx^2$	0	0	0	0	0+0	0	
DC b	0	$-5/2Fx$	0	0	0	0	0+0	0	
CD b	0	$5/2Fb-5/2Fx$	0	0	0	0	0+0	0	
CE b	0	$-3/2Fb+2Fx-1/2qx^2$	0	0	0	0	0+0	0	
EC b	0	$Fx+1/2qx^2$	0	0	0	0	0+0	0	
FG b	$-1/2x/b$	$-Fx$	$-Fb/EJ$	$1/2Fx^2/b$	$1/2Fx/EJ$	$1/4x^2/b^2$	$(1/6+1/4)Fb^2/EJ$	$1/12Xb/EJ$	
GF b	$1/2-1/2x/b$	$Fb-Fx$	Fb/EJ	$1/2Fb-Fx+1/2Fx^2/b$	$1/2Fb/EJ-1/2Fx/EJ$	$1/4-1/2x/b+1/4x^2/b^2$			
GD b	$-1+x/b$	$-1/2Fx$	0	$1/2Fx-1/2Fx^2/b$	0	$1-2x/b+x^2/b^2$	$(1/12+0)Fb^2/EJ$	$1/3Xb/EJ$	
DG b	x/b	$1/2Fb-1/2Fx$	0	$1/2Fx-1/2Fx^2/b$	0	x^2/b^2			
DH b	0	$-Fb+Fx$	0	0	0	0	0+0	0	
HD b	0	Fx	0	0	0	0	0+0	0	
GA b	$1/2-1/2x/b$	$-Fb+Fx$	0	$-1/2Fb+Fx-1/2Fx^2/b$	0	$1/4-1/2x/b+1/4x^2/b^2$	$(-1/6+0)Fb^2/EJ$	$1/12Xb/EJ$	
AG b	$-1/2x/b$	Fx	0	$-1/2Fx^2/b$	0	$1/4x^2/b^2$			
	totali							$1/3Fb^2/EJ$	$1/2Xb/EJ$
	iperstatica $X=W_{GD}$							$-2/3Fb$	

Sviluppi di calcolo iperstatica

$$L_{FG}^{xx} = \int_0^b (1/4 x^2/b^2) 1/EJ dx = [1/12 x^3/b^2]_0^b 1/EJ$$

$$= (1/12 b) 1/EJ = 1/12 b/EJ$$

$$L_{GF}^{xx} = \int_0^b (1/4 - 1/2 x/b + 1/4 x^2/b^2) 1/EJ dx = [1/4 x - 1/4 x^2/b + 1/12 x^3/b^2]_0^b 1/EJ$$

$$= (1/4 b - 1/4 b + 1/12 b) 1/EJ = 1/12 b/EJ$$

$$L_{GD}^{xx} = \int_0^b (1 - 2 x/b + x^2/b^2) 1/EJ dx = [x - x^2/b + 1/3 x^3/b^2]_0^b 1/EJ$$

$$= (b - b + 1/3 b) 1/EJ = 1/3 b/EJ$$

$$L_{DG}^{xx} = \int_0^b (x^2/b^2) 1/EJ dx = [1/3 x^3/b^2]_0^b 1/EJ$$

$$= (1/3 b) 1/EJ = 1/3 b/EJ$$

$$L_{GA}^{xx} = \int_0^b (1/4 - 1/2 x/b + 1/4 x^2/b^2) 1/EJ dx = [1/4 x - 1/4 x^2/b + 1/12 x^3/b^2]_0^b 1/EJ$$

$$= (1/4 b - 1/4 b + 1/12 b) 1/EJ = 1/12 b/EJ$$

$$L_{AG}^{xx} = \int_0^b (1/4 x^2/b^2) 1/EJ dx = [1/12 x^3/b^2]_0^b 1/EJ$$

$$= (1/12 b) 1/EJ = 1/12 b/EJ$$

$$L_{FG}^{xo} = \int_0^b (1/2 x^2/b^2) Fb 1/EJ dx + \int_0^b (1/2 x/b) \theta dx = [1/6 x^3/b^2]_0^b Fb 1/EJ + [1/4 x^2/b]_0^b \theta$$

$$= (1/6 b) Fb 1/EJ + (1/4 b) \theta = 5/12 Fb^2/EJ$$

$$L_{GF}^{xo} = \int_0^b (1/2 - x/b + 1/2 x^2/b^2) Fb 1/EJ dx + \int_0^b (-1/2 + 1/2 x/b) \theta dx$$

$$= [1/2 x - 1/2 x^2/b + 1/6 x^3/b^2]_0^b Fb 1/EJ + [-1/2 x + 1/4 x^2/b]_0^b \theta$$

$$= (1/2 b - 1/2 b + 1/6 b) Fb 1/EJ + (-1/2 b + 1/4 b) \theta = 5/12 Fb^2/EJ$$

$$L_{GD}^{xo} = \int_0^b (1/2 x/b - 1/2 x^2/b^2) Fb 1/EJ dx = [1/4 x^2/b - 1/6 x^3/b^2]_0^b Fb 1/EJ$$

$$= (1/4 b - 1/6 b) Fb 1/EJ = 1/12 Fb^2/EJ$$

$$L_{DG}^{xo} = \int_0^b (1/2 x/b - 1/2 x^2/b^2) Fb 1/EJ dx = [1/4 x^2/b - 1/6 x^3/b^2]_0^b Fb 1/EJ$$

$$= (1/4 b - 1/6 b) Fb 1/EJ = 1/12 Fb^2/EJ$$

$$L_{GA}^{xo} = \int_0^b (-1/2 + x/b - 1/2 x^2/b^2) Fb 1/EJ dx = [-1/2 x + 1/2 x^2/b - 1/6 x^3/b^2]_0^b Fb 1/EJ$$

$$= (-1/2 b + 1/2 b - 1/6 b) Fb 1/EJ = -1/6 Fb^2/EJ$$

$$L_{AG}^{xo} = \int_0^b (-1/2 x^2/b^2) Fb 1/EJ dx = [-1/6 x^3/b^2]_0^b Fb 1/EJ$$

$$= (-1/6 b) Fb 1/EJ = -1/6 Fb^2/EJ$$

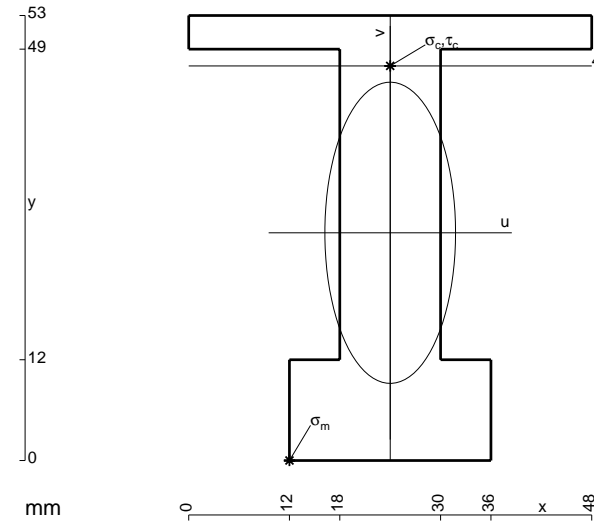

- A = 924. mm²
- J_u = 297390. mm⁴
- J_v = 56016. mm⁴
- y_g = 27.12 mm
- T_y = -2750. N
- M_x = -2612500. Nmm
- x_m = 12. mm
- u_m = -12. mm
- v_m = -27.12 mm
- σ_m = -Mv/J_u = -238.3 N/mm²
- x_c = 24. mm
- y_c = 47. mm
- v_c = 19.88 mm
- σ_c = -Mv/J_u = 174.6 N/mm²
- τ_c = 3.919 N/mm²
- σ_o = √σ²+3τ² = 174.7 N/mm²
- S = 5085. mm³

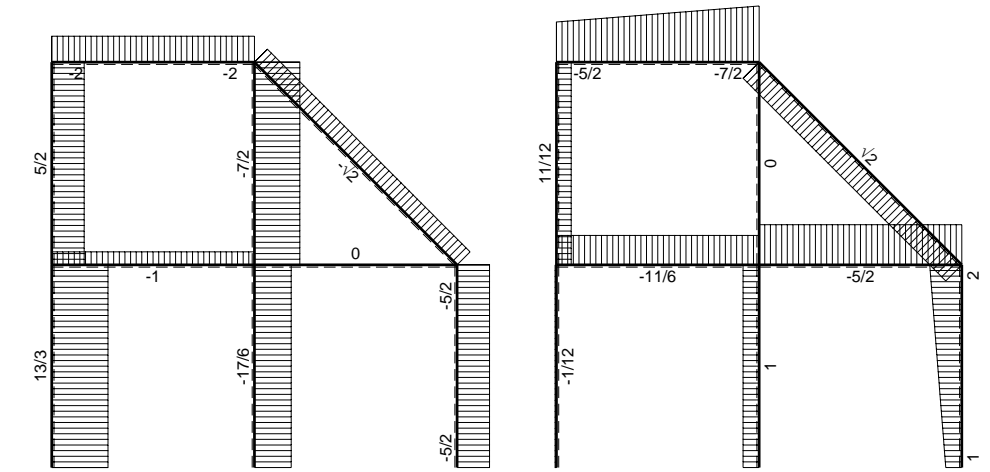
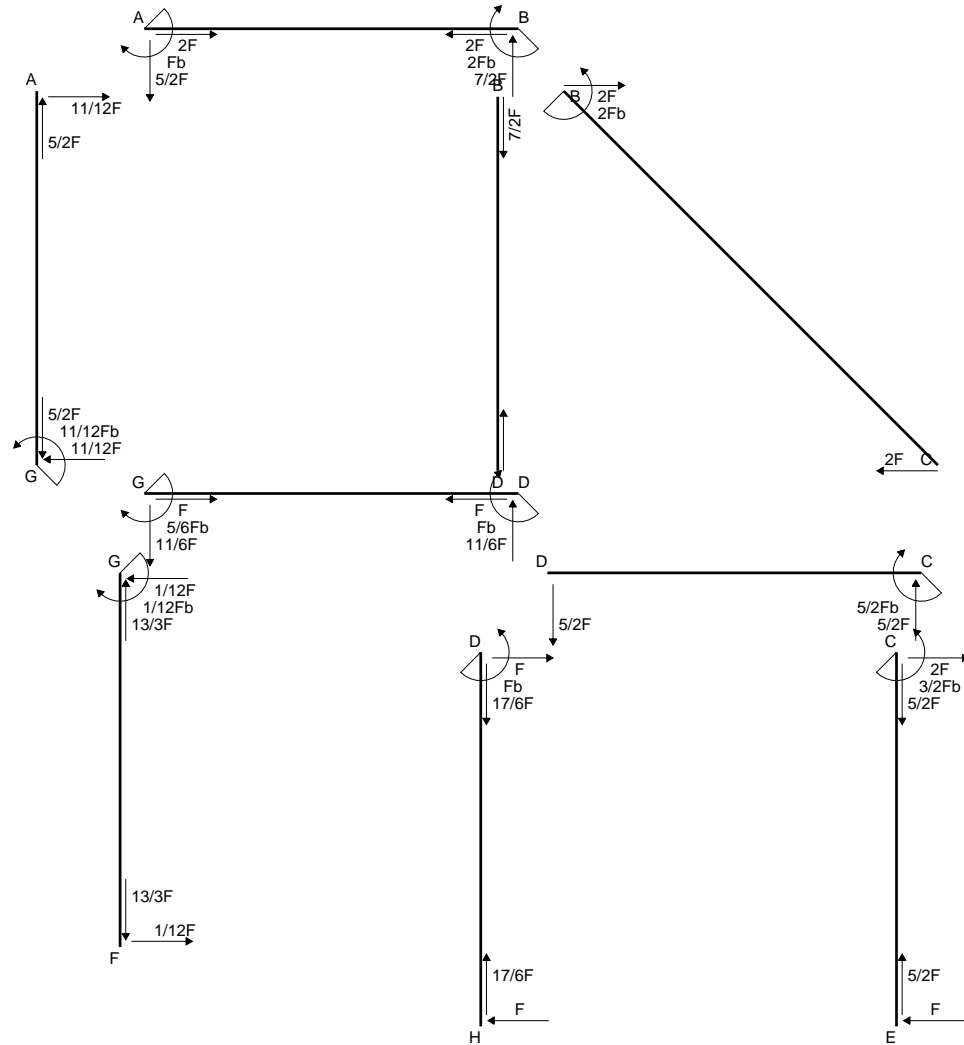

← ⊕ → F

↑ ⊕ ↓ F

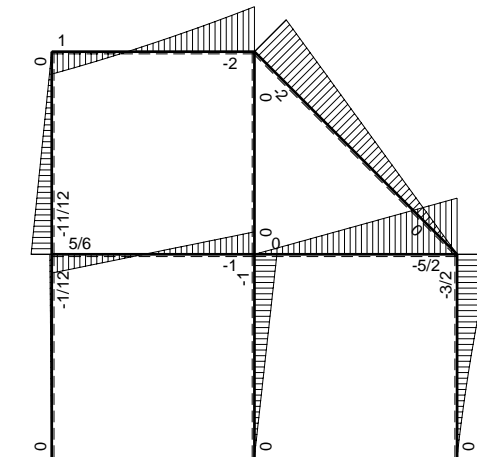

⊕ ⊖ F_b

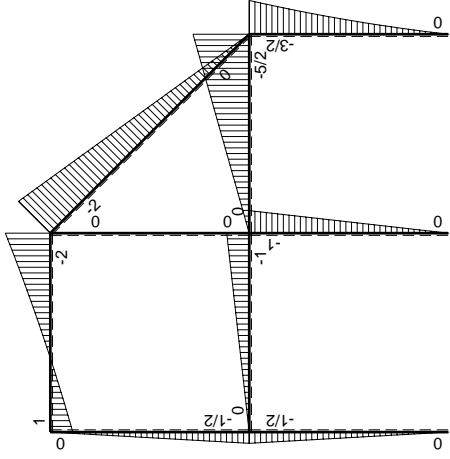
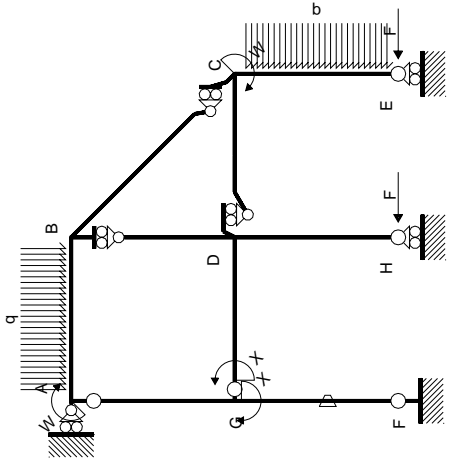

Schema di calcolo iperstatico

M_0 flessione da carichi assegnati

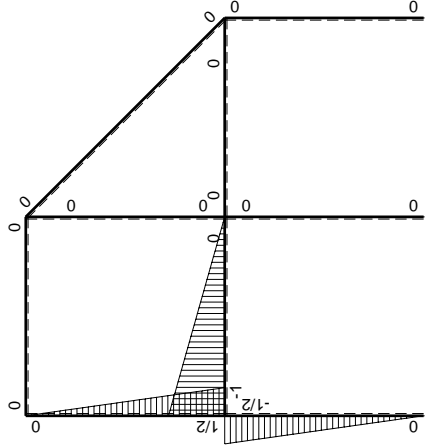

M_x flessione da iperstatica $X=1$

Quadro contributi PLV per iperstatica $X=W_{GD}$

→	$M_x(x)$	$M_o(x)$	θ	$M_x M_o$	$M_x \theta$	$M_x M_x$	$\int M_x(M_o/EJ+\theta)dx$	$\int X M_x M_x/EJ dx$	
AB b	0	$Fb-5/2Fx-1/2qx^2$	0	0	0	0	0+0	0	
BA b	0	$2Fb-7/2Fx+1/2qx^2$	0	0	0	0			
BC $\sqrt{2}b$	0	$-2Fb+\sqrt{2}Fx$	0	0	0	0	0	0	
BD b	0	0	0	0	0	0	0+0	0	
DB b	0	0	0	0	0	0			
DC b	0	$-5/2Fx$	0	0	0	0	0+0	0	
CD b	0	$5/2Fb-5/2Fx$	0	0	0	0			
CE b	0	$-3/2Fb+2Fx-1/2qx^2$	0	0	0	0	0+0	0	
EC b	0	$Fx+1/2qx^2$	0	0	0	0			
FG b	$-1/2x/b$	$-1/2Fx$	$-Fb/EJ$	$1/4Fx^2/b$	$1/2Fx/EJ$	$1/4x^2/b^2$	$(1/12+1/4)Fb^2/EJ$	$1/12Xb/EJ$	
GF b	$1/2-1/2x/b$	$1/2Fb-1/2Fx$	Fb/EJ	$1/4Fb-1/2Fx+1/4Fx^2/b$	$1/2Fb/EJ-1/2Fx/EJ$	$1/4-1/2x/b+1/4x^2/b^2$			
GD b	$-1+x/b$	$-Fx$	0	$Fx-Fx^2/b$	0	$1-2x/b+x^2/b^2$	$(1/6+0)Fb^2/EJ$	$1/3Xb/EJ$	
DG b	x/b	$Fb-Fx$	0	$Fx-Fx^2/b$	0	x^2/b^2			
DH b	0	$-Fb+Fx$	0	0	0	0	0+0	0	
HD b	0	Fx	0	0	0	0			
GA b	$1/2-1/2x/b$	$-1/2Fb+1/2Fx$	0	$-1/4Fb+1/2Fx-1/4Fx^2/b$	0	$1/4-1/2x/b+1/4x^2/b^2$	$(-1/12+0)Fb^2/EJ$	$1/12Xb/EJ$	
AG b	$-1/2x/b$	$1/2Fx$	0	$-1/4Fx^2/b$	0	$1/4x^2/b^2$			
	totali							$5/12Fb^2/EJ$	$1/2Xb/EJ$
	iperstatica $X=W_{GD}$							$-5/6Fb$	

Sviluppi di calcolo iperstatica

$$L_{FG}^{xx} = \int_0^b (1/4 x^2/b^2) 1/EJ dx = [1/12 x^3/b^2]_0^b 1/EJ$$

$$= (1/12 b) 1/EJ = 1/12 b/EJ$$

$$L_{GF}^{xx} = \int_0^b (1/4 - 1/2 x/b + 1/4 x^2/b^2) 1/EJ dx = [1/4 x - 1/4 x^2/b + 1/12 x^3/b^2]_0^b 1/EJ$$

$$= (1/4 b - 1/4 b + 1/12 b) 1/EJ = 1/12 b/EJ$$

$$L_{GD}^{xx} = \int_0^b (1 - 2 x/b + x^2/b^2) 1/EJ dx = [x - x^2/b + 1/3 x^3/b^2]_0^b 1/EJ$$

$$= (b - b + 1/3 b) 1/EJ = 1/3 b/EJ$$

$$L_{DG}^{xx} = \int_0^b (x^2/b^2) 1/EJ dx = [1/3 x^3/b^2]_0^b 1/EJ$$

$$= (1/3 b) 1/EJ = 1/3 b/EJ$$

$$L_{GA}^{xx} = \int_0^b (1/4 - 1/2 x/b + 1/4 x^2/b^2) 1/EJ dx = [1/4 x - 1/4 x^2/b + 1/12 x^3/b^2]_0^b 1/EJ$$

$$= (1/4 b - 1/4 b + 1/12 b) 1/EJ = 1/12 b/EJ$$

$$L_{AG}^{xx} = \int_0^b (1/4 x^2/b^2) 1/EJ dx = [1/12 x^3/b^2]_0^b 1/EJ$$

$$= (1/12 b) 1/EJ = 1/12 b/EJ$$

$$L_{FG}^{xo} = \int_0^b (1/4 x^2/b^2) Fb 1/EJ dx + \int_0^b (1/2 x/b) \theta dx = [1/12 x^3/b^2]_0^b Fb 1/EJ + [1/4 x^2/b]_0^b \theta$$

$$= (1/12 b) Fb 1/EJ + (1/4 b) \theta = 1/3 Fb^2/EJ$$

$$L_{GF}^{xo} = \int_0^b (1/4 - 1/2 x/b + 1/4 x^2/b^2) Fb 1/EJ dx + \int_0^b (-1/2 + 1/2 x/b) \theta dx$$

$$= [1/4 x - 1/4 x^2/b + 1/12 x^3/b^2]_0^b Fb 1/EJ + [-1/2 x + 1/4 x^2/b]_0^b \theta$$

$$= (1/4 b - 1/4 b + 1/12 b) Fb 1/EJ + (-1/2 b + 1/4 b) \theta = 1/3 Fb^2/EJ$$

$$L_{GD}^{xo} = \int_0^b (x/b - x^2/b^2) Fb 1/EJ dx = [1/2 x^2/b - 1/3 x^3/b^2]_0^b Fb 1/EJ$$

$$= (1/2 b - 1/3 b) Fb 1/EJ = 1/6 Fb^2/EJ$$

$$L_{DG}^{xo} = \int_0^b (x/b - x^2/b^2) Fb 1/EJ dx = [1/2 x^2/b - 1/3 x^3/b^2]_0^b Fb 1/EJ$$

$$= (1/2 b - 1/3 b) Fb 1/EJ = 1/6 Fb^2/EJ$$

$$L_{GA}^{xo} = \int_0^b (-1/4 + 1/2 x/b - 1/4 x^2/b^2) Fb 1/EJ dx = [-1/4 x + 1/4 x^2/b - 1/12 x^3/b^2]_0^b Fb 1/EJ$$

$$= (-1/4 b + 1/4 b - 1/12 b) Fb 1/EJ = -1/12 Fb^2/EJ$$

$$L_{AG}^{xo} = \int_0^b (-1/4 x^2/b^2) Fb 1/EJ dx = [-1/12 x^3/b^2]_0^b Fb 1/EJ$$

$$= (-1/12 b) Fb 1/EJ = -1/12 Fb^2/EJ$$

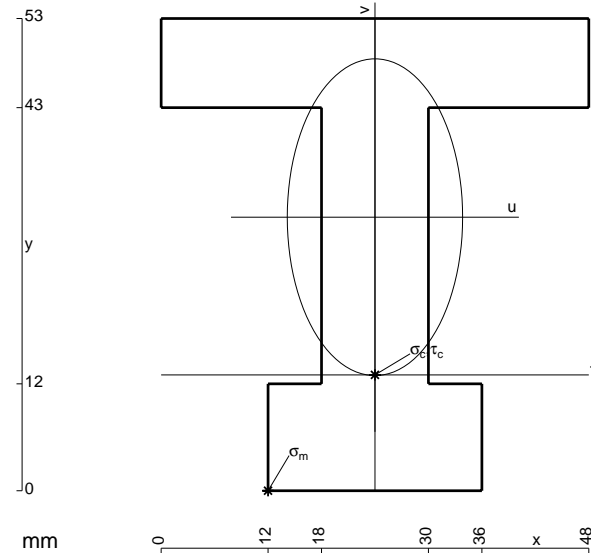

$$A = 1140. \text{ mm}^2$$

$$J_u = 360421. \text{ mm}^4$$

$$J_v = 110448. \text{ mm}^4$$

$$y_g = 30.7 \text{ mm}$$

$$N = -4600. \text{ N}$$

$$T_y = -8050. \text{ N}$$

$$M_x = -2300000. \text{ Nmm}$$

$$x_m = 12. \text{ mm}$$

$$u_m = -12. \text{ mm}$$

$$v_m = -30.7 \text{ mm}$$

$$\sigma_m = N/A - Mv/J_u = -199.9 \text{ N/mm}^2$$

$$x_c = 24. \text{ mm}$$

$$y_c = 13. \text{ mm}$$

$$v_c = -17.7 \text{ mm}$$

$$\sigma_c = N/A - Mv/J_u = -117. \text{ N/mm}^2$$

$$\tau_c = 13.65 \text{ N/mm}^2$$

$$\sigma_q = \sqrt{\sigma^2 + 3\tau^2} = 119.3 \text{ N/mm}^2$$

$$S = 7332. \text{ mm}^3$$

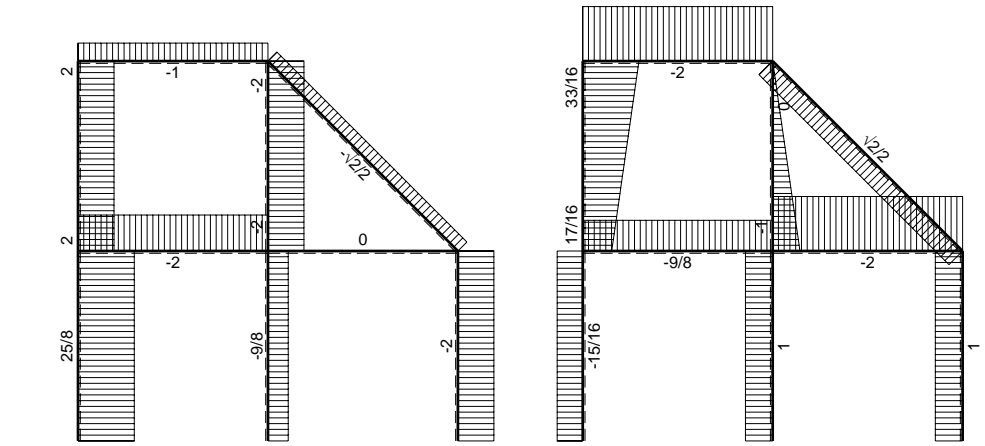
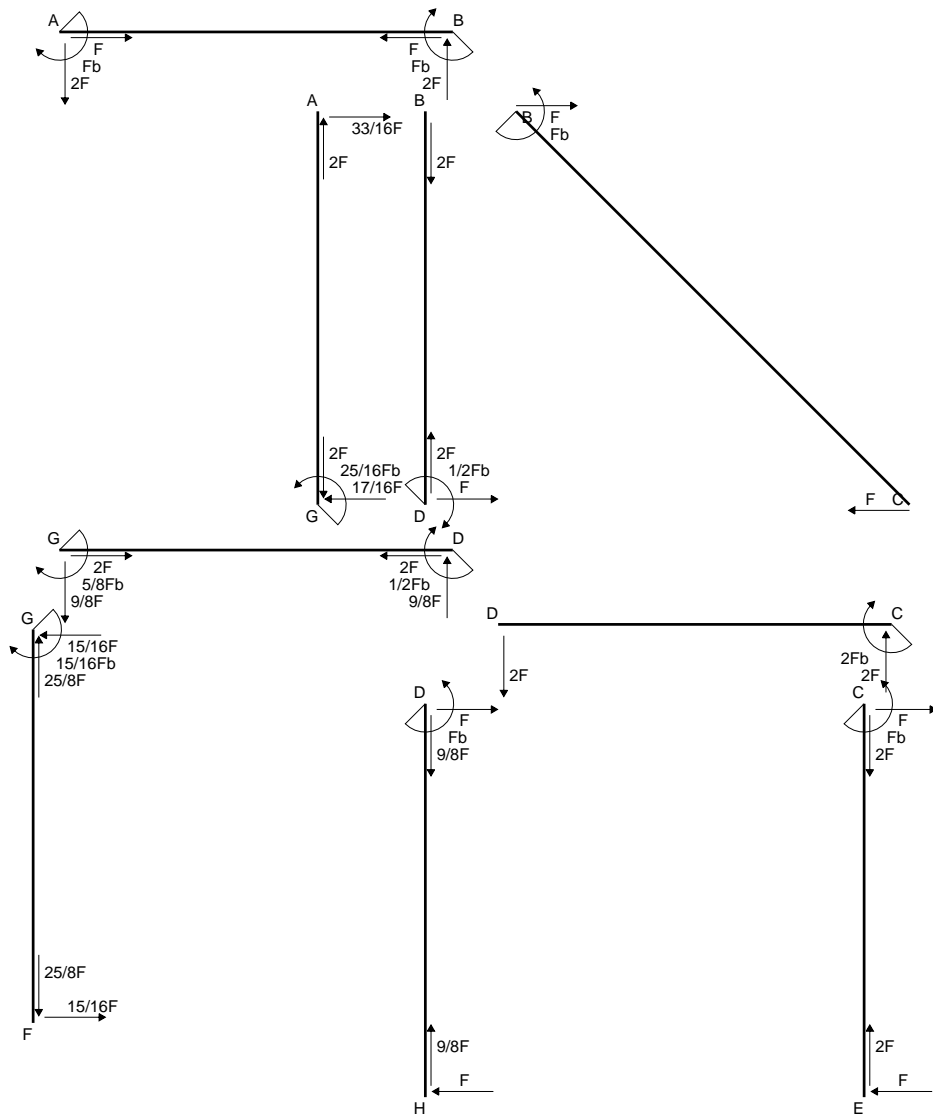

← ⊕ → F

↑ ⊕ ↓ F

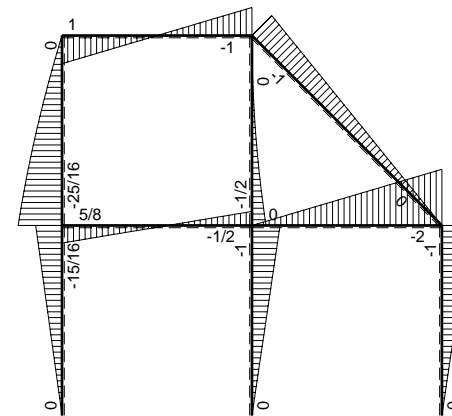

⊕ ⊖ Fb

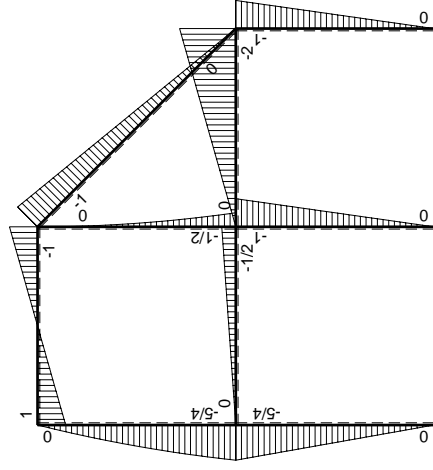
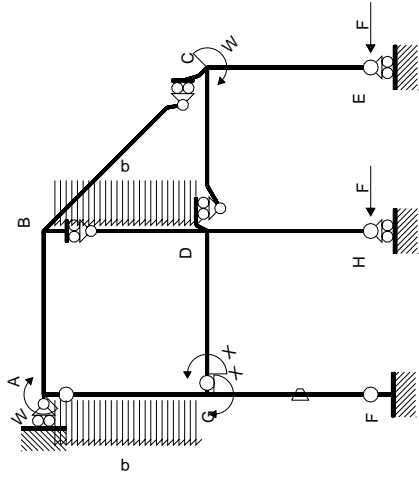

Schema di calcolo iperstatico

M_0 flessione da carichi assegnati

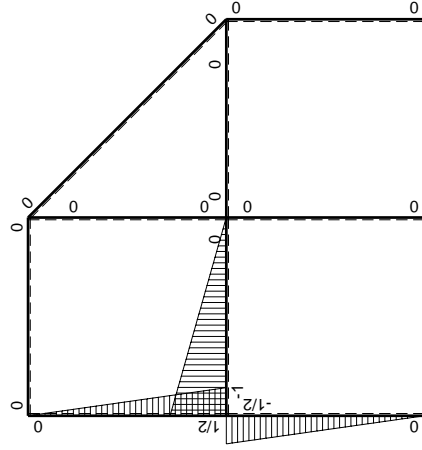

M_x flessione da iperstatica $X=1$

Quadro contributi PLV per iperstatica $X=W_{GD}$

→	$M_x(x)$	$M_o(x)$	θ	$M_x M_o$	$M_x \theta$	$M_x M_x$	$\int M_x(M_o/EJ+\theta)dx$	$\int X M_x M_x/EJ dx$	
AB b	0	Fb-2Fx	0	0	0	0	0+0	0	
BA b	0	Fb-2Fx	0	0	0	0	0	0	
BC $\sqrt{2}b$	0	-Fb+ $\sqrt{2}/2Fx$	0	0	0	0	0	0	
BD b	0	-1/2qx ²	0	0	0	0	0+0	0	
DB b	0	1/2Fb-Fx+1/2qx ²	0	0	0	0	0	0	
DC b	0	-2Fx	0	0	0	0	0+0	0	
CD b	0	2Fb-2Fx	0	0	0	0	0	0	
CE b	0	-Fb+Fx	0	0	0	0	0+0	0	
EC b	0	Fx	0	0	0	0	0	0	
FG b	-1/2x/b	-5/4Fx	-Fb/EJ	5/8Fx ² /b	1/2Fx/EJ	1/4x ² /b ²	(5/24+1/4)Fb ² /EJ	1/12Xb/EJ	
GF b	1/2-1/2x/b	5/4Fb-5/4Fx	Fb/EJ	5/8Fb-5/4Fx+5/8Fx ² /b	1/2Fb/EJ-1/2Fx/EJ	1/4-1/2x/b+1/4x ² /b ²			
GD b	-1+x/b	-1/2Fx	0	1/2Fx-1/2Fx ² /b	0	1-2x/b+x ² /b ²	(1/12+0)Fb ² /EJ	1/3Xb/EJ	
DG b	x/b	1/2Fb-1/2Fx	0	1/2Fx-1/2Fx ² /b	0	x ² /b ²			
DH b	0	-Fb+Fx	0	0	0	0	0+0	0	
HD b	0	Fx	0	0	0	0	0	0	
GA b	1/2-1/2x/b	-5/4Fb+3/4Fx+1/2qx ²	0	-5/8Fb+Fx-1/8Fx ² /b-1/4qx ³ /b	0	1/4-1/2x/b+1/4x ² /b ²	(-11/48+0)Fb ² /EJ	1/12Xb/EJ	
AG b	-1/2x/b	7/4Fx-1/2qx ²	0	-7/8Fx ² /b+1/4qx ³ /b	0	1/4x ² /b ²			
	totali							5/16Fb ² /EJ	1/2Xb/EJ
	iperstatica $X=W_{GD}$							-5/8Fb	

Sviluppi di calcolo iperstatica

$$L_{FG}^{xx} = \int_0^b (1/4 x^2/b^2) 1/EJ dx = [1/12 x^3/b^2]_0^b 1/EJ$$

$$= (1/12 b) 1/EJ = 1/12 b/EJ$$

$$L_{GF}^{xx} = \int_0^b (1/4 -1/2 x/b +1/4 x^2/b^2) 1/EJ dx = [1/4 x -1/4 x^2/b +1/12 x^3/b^2]_0^b 1/EJ$$

$$= (1/4 b -1/4 b +1/12 b) 1/EJ = 1/12 b/EJ$$

$$L_{GD}^{xx} = \int_0^b (1 -2 x/b + x^2/b^2) 1/EJ dx = [x - x^2/b +1/3 x^3/b^2]_0^b 1/EJ$$

$$= (b - b +1/3 b) 1/EJ = 1/3 b/EJ$$

$$L_{DG}^{xx} = \int_0^b (x^2/b^2) 1/EJ dx = [1/3 x^3/b^2]_0^b 1/EJ$$

$$= (1/3 b) 1/EJ = 1/3 b/EJ$$

$$L_{GA}^{xx} = \int_0^b (1/4 -1/2 x/b +1/4 x^2/b^2) 1/EJ dx = [1/4 x -1/4 x^2/b +1/12 x^3/b^2]_0^b 1/EJ$$

$$= (1/4 b -1/4 b +1/12 b) 1/EJ = 1/12 b/EJ$$

$$L_{AG}^{xx} = \int_0^b (1/4 x^2/b^2) 1/EJ dx = [1/12 x^3/b^2]_0^b 1/EJ$$

$$= (1/12 b) 1/EJ = 1/12 b/EJ$$

$$L_{FG}^{xo} = \int_0^b (5/8 x^2/b^2) Fb 1/EJ dx + \int_0^b (1/2 x/b) \theta dx = [5/24 x^3/b^2]_0^b Fb 1/EJ + [1/4 x^2/b]_0^b \theta$$

$$= (5/24 b) Fb 1/EJ + (1/4 b) \theta = 11/24 Fb^2/EJ$$

$$L_{GF}^{xo} = \int_0^b (5/8 -5/4 x/b +5/8 x^2/b^2) Fb 1/EJ dx + \int_0^b (-1/2 +1/2 x/b) \theta dx$$

$$= [5/8 x -5/8 x^2/b +5/24 x^3/b^2]_0^b Fb 1/EJ + [-1/2 x +1/4 x^2/b]_0^b \theta$$

$$= (5/8 b -5/8 b +5/24 b) Fb 1/EJ + (-1/2 b +1/4 b) \theta = 11/24 Fb^2/EJ$$

$$L_{GD}^{xo} = \int_0^b (1/2 x/b -1/2 x^2/b^2) Fb 1/EJ dx = [1/4 x^2/b -1/6 x^3/b^2]_0^b Fb 1/EJ$$

$$= (1/4 b -1/6 b) Fb 1/EJ = 1/12 Fb^2/EJ$$

$$L_{DG}^{xo} = \int_0^b (1/2 x/b -1/2 x^2/b^2) Fb 1/EJ dx = [1/4 x^2/b -1/6 x^3/b^2]_0^b Fb 1/EJ$$

$$= (1/4 b -1/6 b) Fb 1/EJ = 1/12 Fb^2/EJ$$

$$L_{GA}^{xo} = \int_0^b (-5/8 + x/b -1/8 x^2/b^2 -1/4 x^3/b^3) Fb 1/EJ dx$$

$$= [-5/8 x +1/2 x^2/b -1/24 x^3/b^2 -1/16 x^4/b^3]_0^b Fb 1/EJ$$

$$= (-5/8 b +1/2 b -1/24 b -1/16 b) Fb 1/EJ = -11/48 Fb^2/EJ$$

$$L_{AG}^{xo} = \int_0^b (-7/8 x^2/b^2 +1/4 x^3/b^3) Fb 1/EJ dx = [-7/24 x^3/b^2 +1/16 x^4/b^3]_0^b Fb 1/EJ$$

$$= (-7/24 b +1/16 b) Fb 1/EJ = -11/48 Fb^2/EJ$$

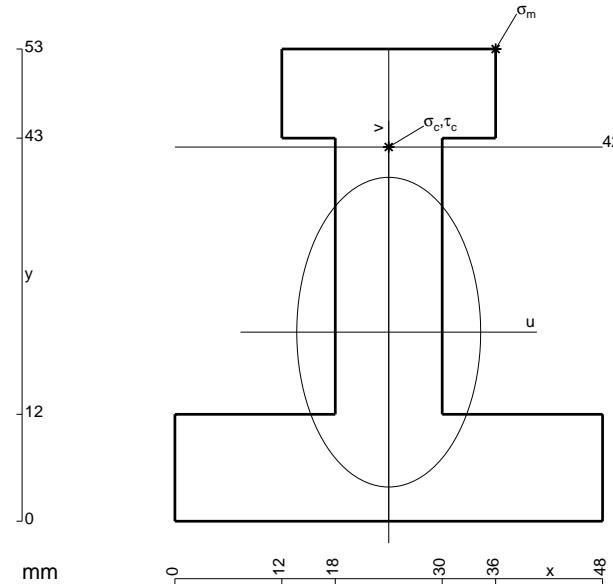

$$A = 1188. \text{ mm}^2$$

$$J_u = 358924. \text{ mm}^4$$

$$J_v = 126576. \text{ mm}^4$$

$$y_g = 21.22 \text{ mm}$$

$$T_y = -4300. \text{ N}$$

$$M_x = -2365000. \text{ Nmm}$$

$$x_m = 36. \text{ mm}$$

$$y_m = 53. \text{ mm}$$

$$u_m = 12. \text{ mm}$$

$$v_m = 31.78 \text{ mm}$$

$$\sigma_m = -Mv/J_u = 209.4 \text{ N/mm}^2$$

$$x_c = 24. \text{ mm}$$

$$y_c = 42. \text{ mm}$$

$$v_c = 20.78 \text{ mm}$$

$$\sigma_c = -Mv/J_u = 136.9 \text{ N/mm}^2$$

$$\tau_c = 6.672 \text{ N/mm}^2$$

$$\sigma_o = \sqrt{\sigma^2 + 3\tau^2} = 137.4 \text{ N/mm}^2$$

$$S = 6683. \text{ mm}^3$$

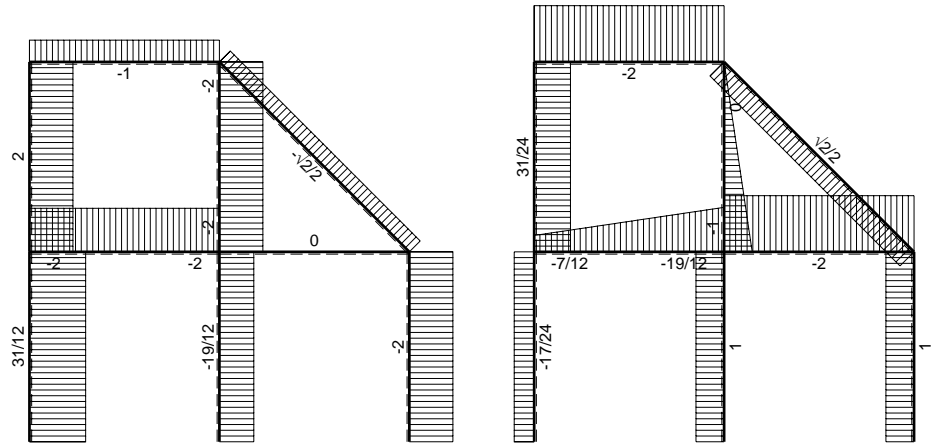
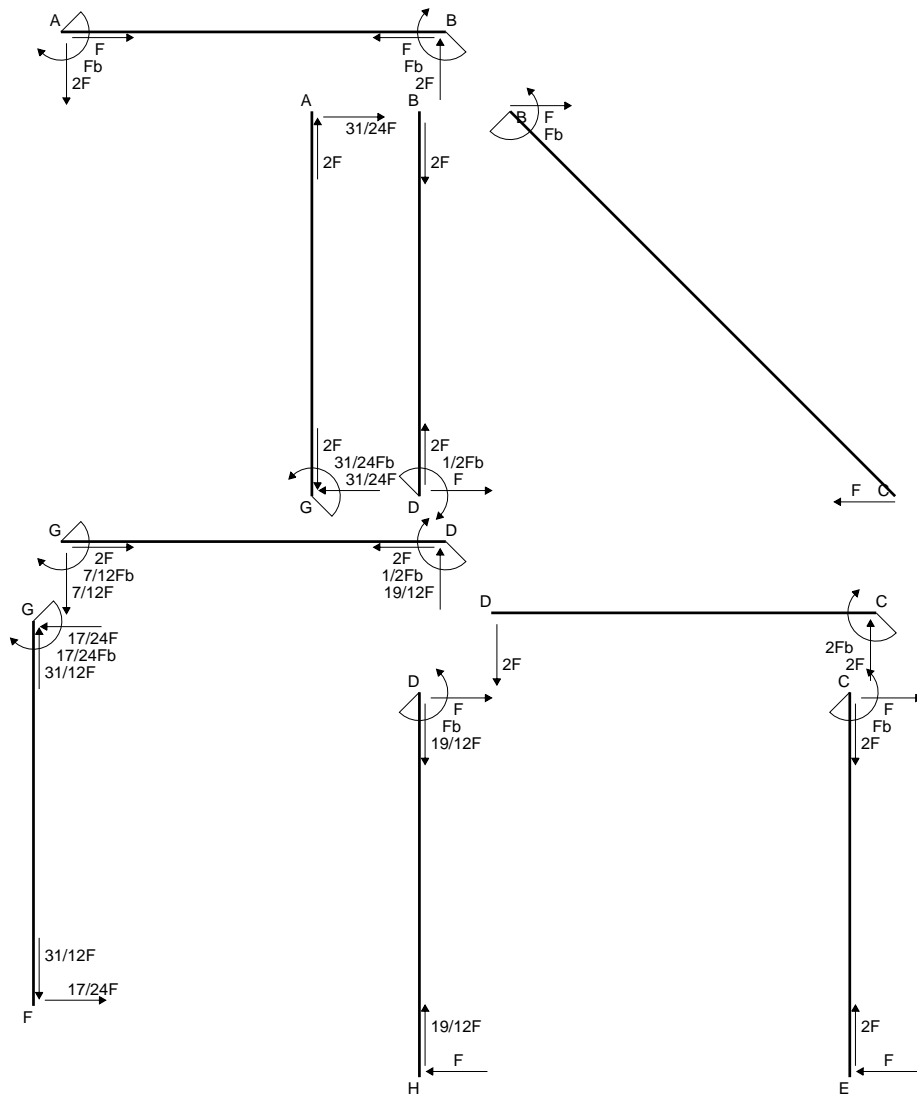

← ⊕ → F

↑ ⊕ ↓ F

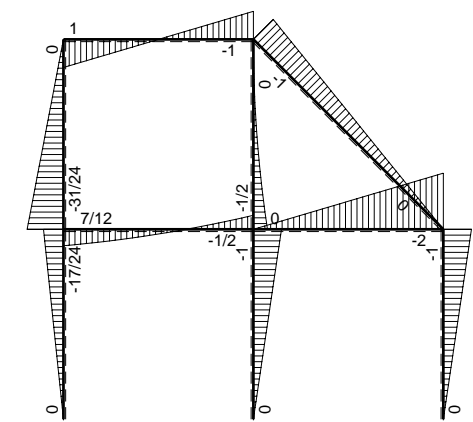

⊕ ⊖ F_b

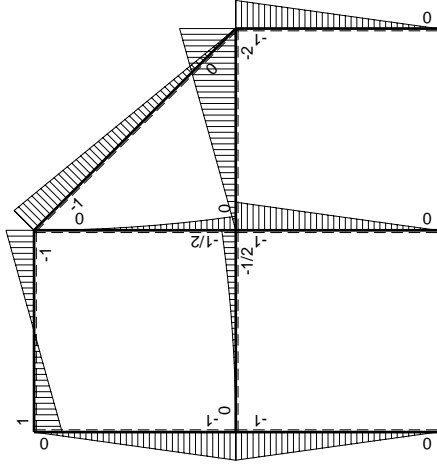
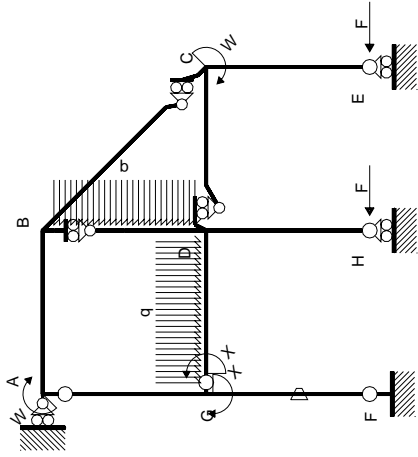

Schema di calcolo iperstatico

M_0 flessione da carichi assegnati

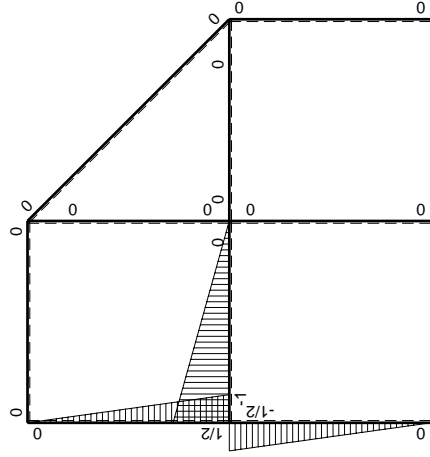

M_1 flessione da iperstatica $X=1$

Quadro contributi PLV per iperstatica $X=W_{GD}$

→	$M_x(x)$	$M_o(x)$	θ	$M_x M_o$	$M_x \theta$	$M_x M_x$	$\int M_x(M_o/EJ+\theta)dx$	$\int X M_x M_x/EJdx$
AB b	0	Fb-2Fx	0	0	0	0	0+0	0
BA b	0	Fb-2Fx	0	0	0	0	0	0
BC $\sqrt{2}b$	0	-Fb+ $\sqrt{2}/2Fx$	0	0	0	0	0	0
BD b	0	-1/2qx ²	0	0	0	0	0+0	0
DB b	0	1/2Fb-Fx+1/2qx ²	0	0	0	0	0	0
DC b	0	-2Fx	0	0	0	0	0+0	0
CD b	0	2Fb-2Fx	0	0	0	0	0	0
CE b	0	-Fb+Fx	0	0	0	0	0+0	0
EC b	0	Fx	0	0	0	0	0	0
FG b	-1/2x/b	-Fx	-Fb/EJ	1/2Fx ² /b	1/2Fx/EJ	1/4x ² /b ²	(1/6+1/4)Fb ² /EJ	1/12Xb/EJ
GF b	1/2-1/2x/b	Fb-Fx	Fb/EJ	1/2Fb-Fx+1/2Fx ² /b	1/2Fb/EJ-1/2Fx/EJ	1/4-1/2x/b+1/4x ² /b ²		
GD b	-1+x/b	-1/2qx ²	0	1/2Fx ² /b-1/2qx ³ /b	0	1-2x/b+x ² /b ²	(1/24+0)Fb ² /EJ	1/3Xb/EJ
DG b	x/b	1/2Fb-Fx+1/2qx ²	0	1/2Fx-Fx ² /b+1/2qx ³ /b	0	x ² /b ²		
DH b	0	-Fb+Fx	0	0	0	0	0+0	0
HD b	0	Fx	0	0	0	0	0	0
GA b	1/2-1/2x/b	-Fb+Fx	0	-1/2Fb+Fx-1/2Fx ² /b	0	1/4-1/2x/b+1/4x ² /b ²	(-1/6+0)Fb ² /EJ	1/12Xb/EJ
AG b	-1/2x/b	Fx	0	-1/2Fx ² /b	0	1/4x ² /b ²		
	totali						7/24Fb ² /EJ	1/2Xb/EJ
	iperstatica $X=W_{GD}$						-7/12Fb	

Sviluppi di calcolo iperstatica

$$L_{FG}^{xx} = \int_0^b (1/4 x^2/b^2) 1/EJ dx = [1/12 x^3/b^2]_0^b 1/EJ$$

$$= (1/12 b) 1/EJ = 1/12 b/EJ$$

$$L_{GF}^{xx} = \int_0^b (1/4 - 1/2 x/b + 1/4 x^2/b^2) 1/EJ dx = [1/4 x - 1/4 x^2/b + 1/12 x^3/b^2]_0^b 1/EJ$$

$$= (1/4 b - 1/4 b + 1/12 b) 1/EJ = 1/12 b/EJ$$

$$L_{GD}^{xx} = \int_0^b (1 - 2 x/b + x^2/b^2) 1/EJ dx = [x - x^2/b + 1/3 x^3/b^2]_0^b 1/EJ$$

$$= (b - b + 1/3 b) 1/EJ = 1/3 b/EJ$$

$$L_{DG}^{xx} = \int_0^b (x^2/b^2) 1/EJ dx = [1/3 x^3/b^2]_0^b 1/EJ$$

$$= (1/3 b) 1/EJ = 1/3 b/EJ$$

$$L_{GA}^{xx} = \int_0^b (1/4 - 1/2 x/b + 1/4 x^2/b^2) 1/EJ dx = [1/4 x - 1/4 x^2/b + 1/12 x^3/b^2]_0^b 1/EJ$$

$$= (1/4 b - 1/4 b + 1/12 b) 1/EJ = 1/12 b/EJ$$

$$L_{AG}^{xx} = \int_0^b (1/4 x^2/b^2) 1/EJ dx = [1/12 x^3/b^2]_0^b 1/EJ$$

$$= (1/12 b) 1/EJ = 1/12 b/EJ$$

$$L_{FG}^{xo} = \int_0^b (1/2 x^2/b^2) Fb 1/EJ dx + \int_0^b (1/2 x/b) \theta dx = [1/6 x^3/b^2]_0^b Fb 1/EJ + [1/4 x^2/b]_0^b \theta$$

$$= (1/6 b) Fb 1/EJ + (1/4 b) \theta = 5/12 Fb^2/EJ$$

$$L_{GF}^{xo} = \int_0^b (1/2 - x/b + 1/2 x^2/b^2) Fb 1/EJ dx + \int_0^b (-1/2 + 1/2 x/b) \theta dx$$

$$= [1/2 x - 1/2 x^2/b + 1/6 x^3/b^2]_0^b Fb 1/EJ + [-1/2 x + 1/4 x^2/b]_0^b \theta$$

$$= (1/2 b - 1/2 b + 1/6 b) Fb 1/EJ + (-1/2 b + 1/4 b) \theta = 5/12 Fb^2/EJ$$

$$L_{GD}^{xo} = \int_0^b (1/2 x^2/b^2 - 1/2 x^3/b^3) Fb 1/EJ dx = [1/6 x^3/b^2 - 1/8 x^4/b^3]_0^b Fb 1/EJ$$

$$= (1/6 b - 1/8 b) Fb 1/EJ = 1/24 Fb^2/EJ$$

$$L_{DG}^{xo} = \int_0^b (1/2 x/b - x^2/b^2 + 1/2 x^3/b^3) Fb 1/EJ dx = [1/4 x^2/b - 1/3 x^3/b^2 + 1/8 x^4/b^3]_0^b Fb 1/EJ$$

$$= (1/4 b - 1/3 b + 1/8 b) Fb 1/EJ = 1/24 Fb^2/EJ$$

$$L_{GA}^{xo} = \int_0^b (-1/2 + x/b - 1/2 x^2/b^2) Fb 1/EJ dx = [-1/2 x + 1/2 x^2/b - 1/6 x^3/b^2]_0^b Fb 1/EJ$$

$$= (-1/2 b + 1/2 b - 1/6 b) Fb 1/EJ = -1/6 Fb^2/EJ$$

$$L_{AG}^{xo} = \int_0^b (-1/2 x^2/b^2) Fb 1/EJ dx = [-1/6 x^3/b^2]_0^b Fb 1/EJ$$

$$= (-1/6 b) Fb 1/EJ = -1/6 Fb^2/EJ$$

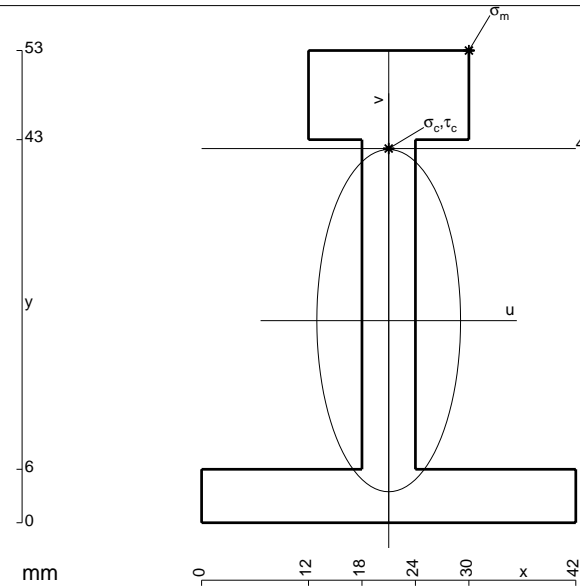

- A = 654. mm²
- J_u = 241316. mm⁴
- J_v = 42570. mm⁴
- y_g = 22.68 mm
- T_y = -2900. N
- M_x = -1740000. Nmm
- x_m = 30. mm
- y_m = 53. mm
- u_m = 9. mm
- v_m = 30.32 mm
- σ_m = -Mv/J_u = 218.6 N/mm²
- x_c = 21. mm
- y_c = 42. mm
- v_c = 19.32 mm
- σ_c = -Mv/J_u = 139.3 N/mm²
- τ_c = 9.365 N/mm²
- σ_q = √σ²+3τ² = 140.2 N/mm²
- S = 4676. mm³

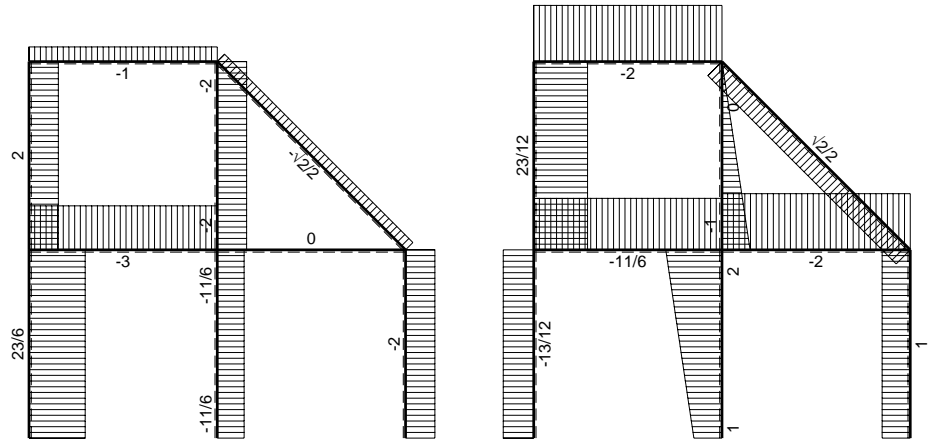
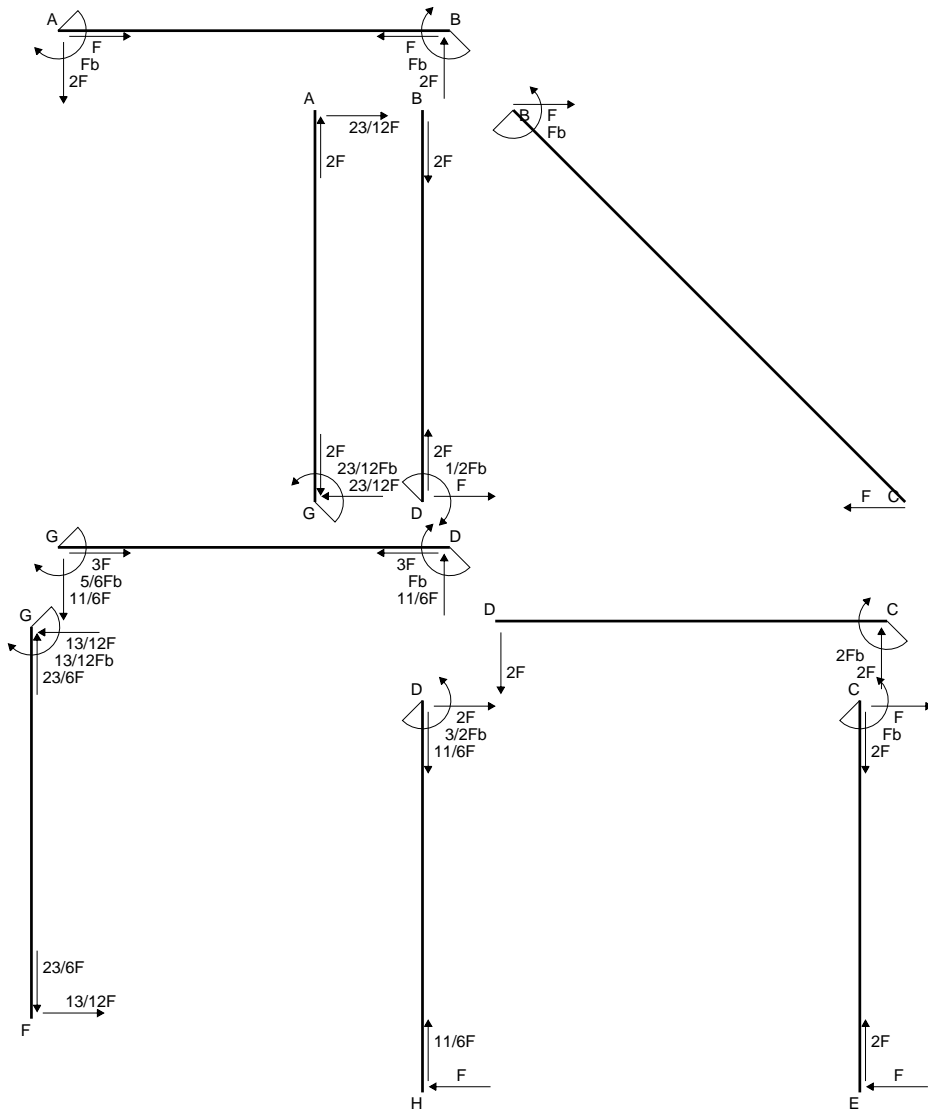

← ⊕ → F

↑ ⊕ ↓ F

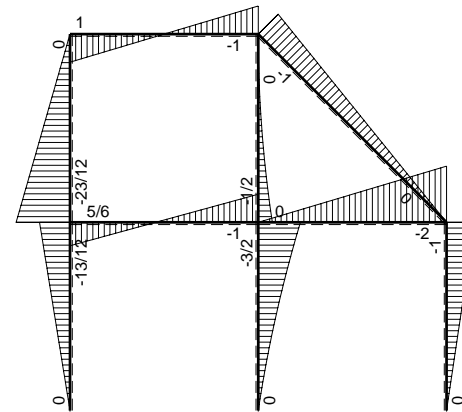

⊕ ⊖ Fb

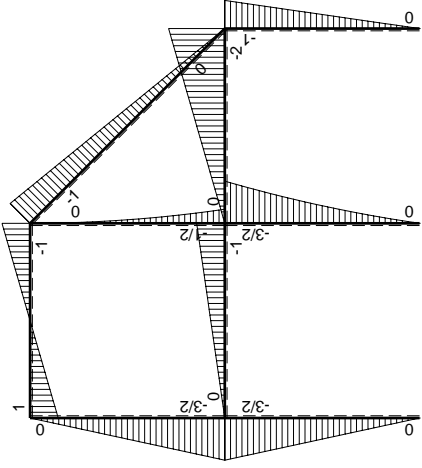
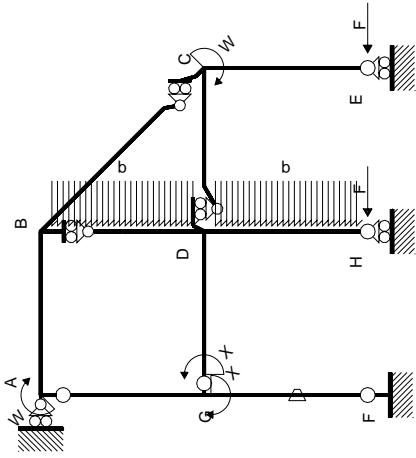

Schema di calcolo iperstatico

M_0 flessione da carichi assegnati

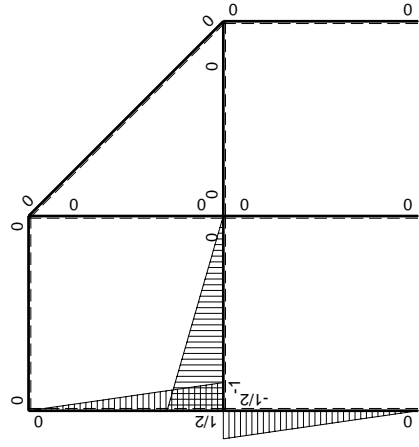

M_x flessione da iperstatica $X=1$

Quadro contributi PLV per iperstatica $X=W_{GD}$

→	$M_x(x)$	$M_o(x)$	θ	$M_x M_o$	$M_x \theta$	$M_x M_x$	$\int M_x(M_o/EJ+\theta)dx$	$\int X M_x M_x/EJdx$	
AB b	0	Fb-2Fx	0	0	0	0	0+0	0	
BA b	0	Fb-2Fx	0	0	0	0			
BC $\sqrt{2}b$	0	-Fb+ $\sqrt{2}/2Fx$	0	0	0	0	0	0	
BD b	0	-1/2qx ²	0	0	0	0	0+0	0	
DB b	0	1/2Fb-Fx+1/2qx ²	0	0	0	0			
DC b	0	-2Fx	0	0	0	0	0+0	0	
CD b	0	2Fb-2Fx	0	0	0	0			
CE b	0	-Fb+Fx	0	0	0	0	0+0	0	
EC b	0	Fx	0	0	0	0			
FG b	-1/2x/b	-3/2Fx	-Fb/EJ	3/4Fx ² /b	1/2Fx/EJ	1/4x ² /b ²	(1/4+1/4)Fb ² /EJ	1/12Xb/EJ	
GF b	1/2-1/2x/b	3/2Fb-3/2Fx	Fb/EJ	3/4Fb-3/2Fx+3/4Fx ² /b	1/2Fb/EJ-1/2Fx/EJ	1/4-1/2x/b+1/4x ² /b ²			
GD b	-1+x/b	-Fx	0	Fx-Fx ² /b	0	1-2x/b+x ² /b ²	(1/6+0)Fb ² /EJ	1/3Xb/EJ	
DG b	x/b	Fb-Fx	0	Fx-Fx ² /b	0	x ² /b ²			
DH b	0	-3/2Fb+2Fx-1/2qx ²	0	0	0	0	0+0	0	
HD b	0	Fx+1/2qx ²	0	0	0	0			
GA b	1/2-1/2x/b	-3/2Fb+3/2Fx	0	-3/4Fb+3/2Fx-3/4Fx ² /b	0	1/4-1/2x/b+1/4x ² /b ²	(-1/4+0)Fb ² /EJ	1/12Xb/EJ	
AG b	-1/2x/b	3/2Fx	0	-3/4Fx ² /b	0	1/4x ² /b ²			
	totali							5/12Fb ² /EJ	1/2Xb/EJ
	iperstatica $X=W_{GD}$							-5/6Fb	

Sviluppi di calcolo iperstatica

$$L_{FG}^{xx} = \int_0^b (1/4 x^2/b^2) 1/EJ dx = [1/12 x^3/b^2]_0^b 1/EJ$$

$$= (1/12 b) 1/EJ = 1/12 b/EJ$$

$$L_{GF}^{xx} = \int_0^b (1/4 - 1/2 x/b + 1/4 x^2/b^2) 1/EJ dx = [1/4 x - 1/4 x^2/b + 1/12 x^3/b^2]_0^b 1/EJ$$

$$= (1/4 b - 1/4 b + 1/12 b) 1/EJ = 1/12 b/EJ$$

$$L_{GD}^{xx} = \int_0^b (1 - 2 x/b + x^2/b^2) 1/EJ dx = [x - x^2/b + 1/3 x^3/b^2]_0^b 1/EJ$$

$$= (b - b + 1/3 b) 1/EJ = 1/3 b/EJ$$

$$L_{DG}^{xx} = \int_0^b (x^2/b^2) 1/EJ dx = [1/3 x^3/b^2]_0^b 1/EJ$$

$$= (1/3 b) 1/EJ = 1/3 b/EJ$$

$$L_{GA}^{xx} = \int_0^b (1/4 - 1/2 x/b + 1/4 x^2/b^2) 1/EJ dx = [1/4 x - 1/4 x^2/b + 1/12 x^3/b^2]_0^b 1/EJ$$

$$= (1/4 b - 1/4 b + 1/12 b) 1/EJ = 1/12 b/EJ$$

$$L_{AG}^{xx} = \int_0^b (1/4 x^2/b^2) 1/EJ dx = [1/12 x^3/b^2]_0^b 1/EJ$$

$$= (1/12 b) 1/EJ = 1/12 b/EJ$$

$$L_{FG}^{xo} = \int_0^b (3/4 x^2/b^2) Fb 1/EJ dx + \int_0^b (1/2 x/b) \theta dx = [1/4 x^3/b^2]_0^b Fb 1/EJ + [1/4 x^2/b]_0^b \theta$$

$$= (1/4 b) Fb 1/EJ + (1/4 b) \theta = 1/2 Fb^2/EJ$$

$$L_{GF}^{xo} = \int_0^b (3/4 - 3/2 x/b + 3/4 x^2/b^2) Fb 1/EJ dx + \int_0^b (-1/2 + 1/2 x/b) \theta dx$$

$$= [3/4 x - 3/4 x^2/b + 1/4 x^3/b^2]_0^b Fb 1/EJ + [-1/2 x + 1/4 x^2/b]_0^b \theta$$

$$= (3/4 b - 3/4 b + 1/4 b) Fb 1/EJ + (-1/2 b + 1/4 b) \theta = 1/2 Fb^2/EJ$$

$$L_{GD}^{xo} = \int_0^b (x/b - x^2/b^2) Fb 1/EJ dx = [1/2 x^2/b - 1/3 x^3/b^2]_0^b Fb 1/EJ$$

$$= (1/2 b - 1/3 b) Fb 1/EJ = 1/6 Fb^2/EJ$$

$$L_{DG}^{xo} = \int_0^b (x/b - x^2/b^2) Fb 1/EJ dx = [1/2 x^2/b - 1/3 x^3/b^2]_0^b Fb 1/EJ$$

$$= (1/2 b - 1/3 b) Fb 1/EJ = 1/6 Fb^2/EJ$$

$$L_{GA}^{xo} = \int_0^b (-3/4 + 3/2 x/b - 3/4 x^2/b^2) Fb 1/EJ dx = [-3/4 x + 3/4 x^2/b - 1/4 x^3/b^2]_0^b Fb 1/EJ$$

$$= (-3/4 b + 3/4 b - 1/4 b) Fb 1/EJ = -1/4 Fb^2/EJ$$

$$L_{AG}^{xo} = \int_0^b (-3/4 x^2/b^2) Fb 1/EJ dx = [-1/4 x^3/b^2]_0^b Fb 1/EJ$$

$$= (-1/4 b) Fb 1/EJ = -1/4 Fb^2/EJ$$

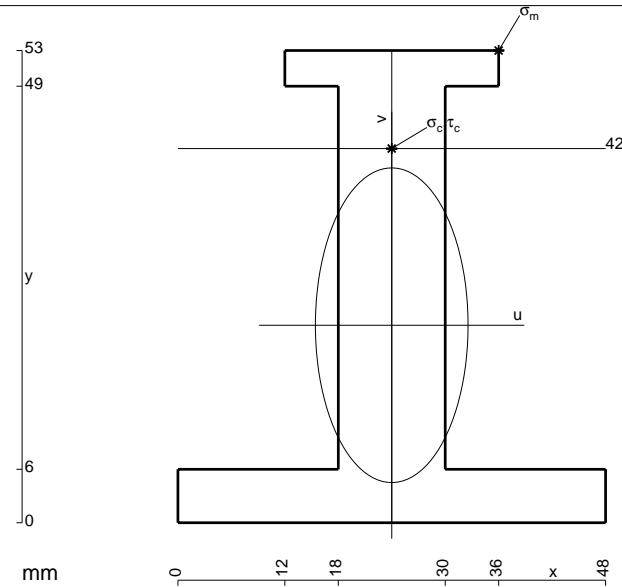

$$A = 900. \text{ mm}^2$$

$$J_u = 280787. \text{ mm}^4$$

$$J_v = 66096. \text{ mm}^4$$

$$y_g = 22.17 \text{ mm}$$

$$T_y = -3220. \text{ N}$$

$$M_x = -2093000. \text{ Nmm}$$

$$x_m = 36. \text{ mm}$$

$$y_m = 53. \text{ mm}$$

$$u_m = 12. \text{ mm}$$

$$v_m = 30.83 \text{ mm}$$

$$\sigma_m = -Mv/J_u = 229.8 \text{ N/mm}^2$$

$$x_c = 24. \text{ mm}$$

$$y_c = 42. \text{ mm}$$

$$v_c = 19.83 \text{ mm}$$

$$\sigma_c = -Mv/J_u = 147.8 \text{ N/mm}^2$$

$$\tau_c = 4.518 \text{ N/mm}^2$$

$$\sigma_\rho = \sqrt{\sigma^2 + 3\tau^2} = 148. \text{ N/mm}^2$$

$$S = 4728. \text{ mm}^3$$

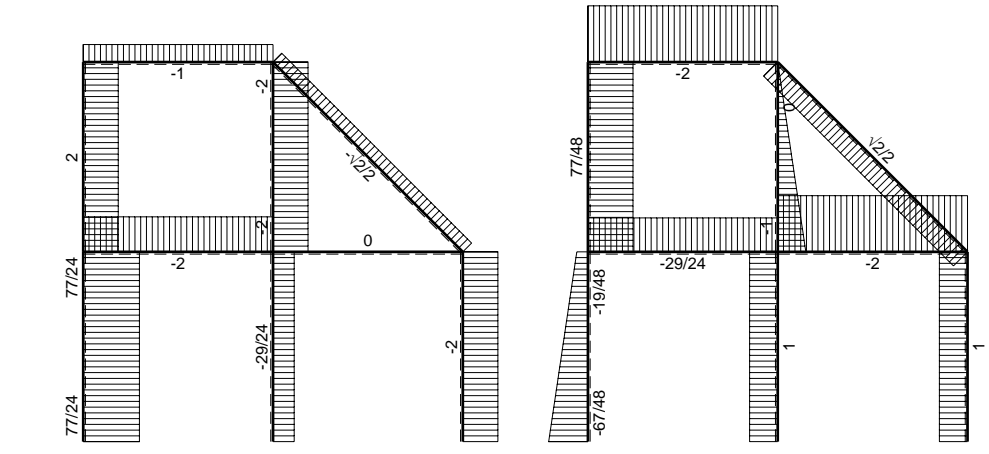
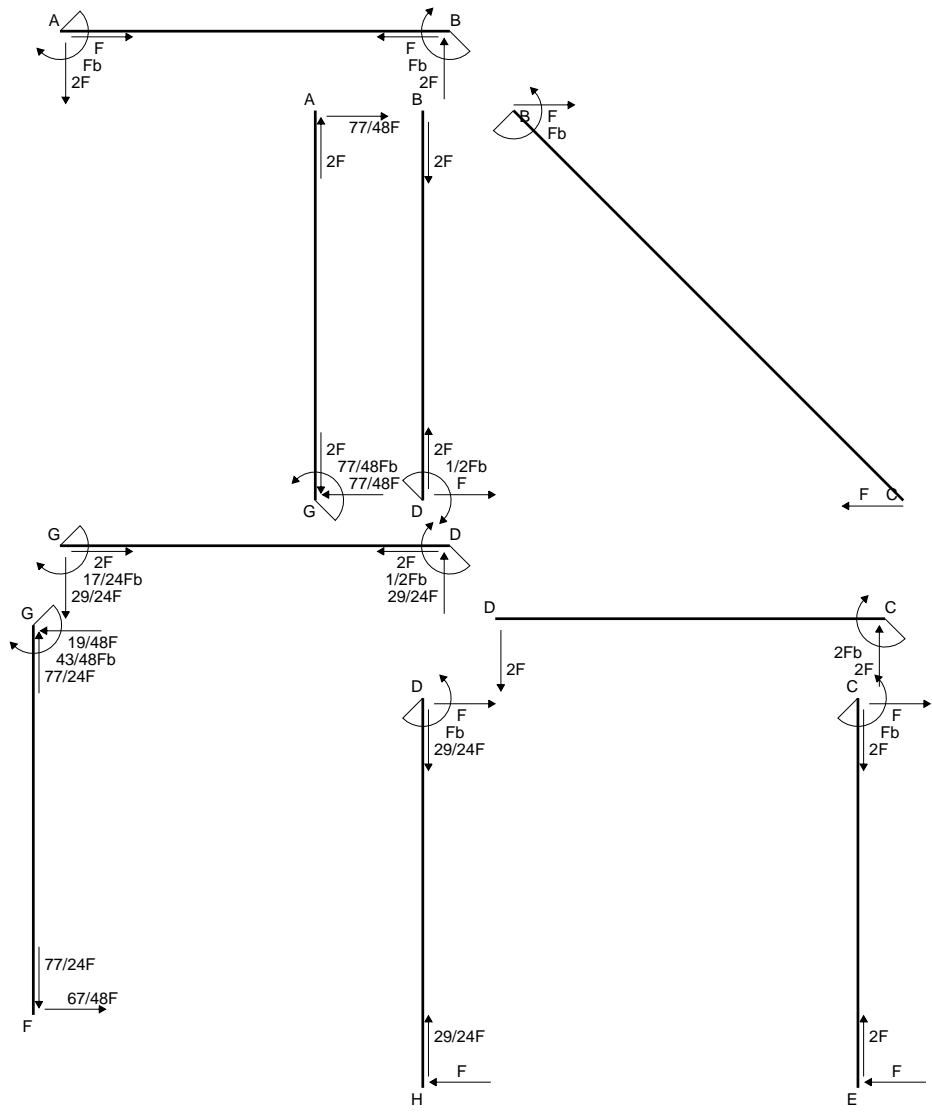

← ⊕ → F

↑ ⊕ ↓ F

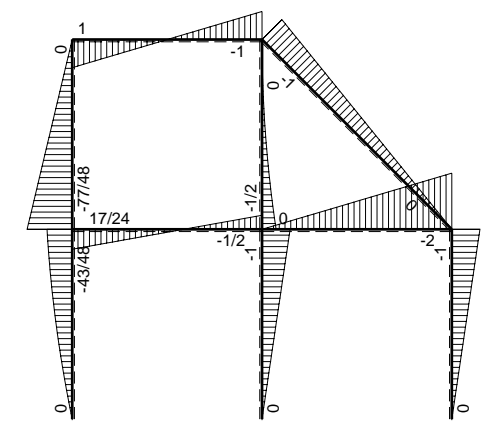

⊕ ⊖ F_b

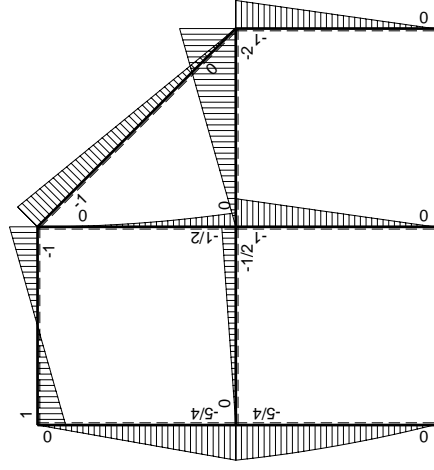
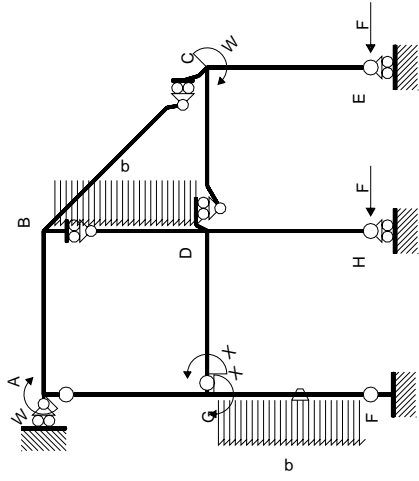

Schema di calcolo iperstatico

M_0 flessione da carichi assegnati

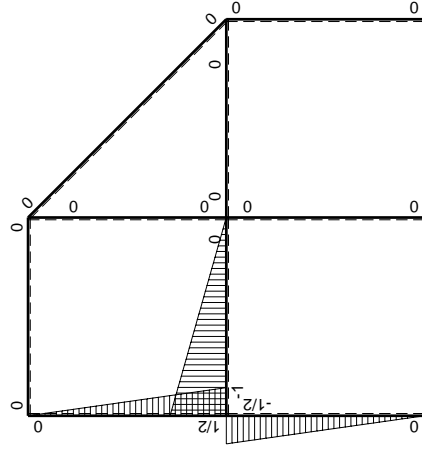

M_x flessione da iperstatica $X=1$

Quadro contributi PLV per iperstatica $X=W_{GD}$

→	$M_x(x)$	$M_o(x)$	θ	$M_x M_o$	$M_x \theta$	$M_x M_x$	$\int M_x(M_o/EJ+\theta)dx$	$\int X M_x M_x / EJ dx$
AB b	0	Fb-2Fx	0	0	0	0	0+0	0
BA b	0	Fb-2Fx	0	0	0	0	0	0
BC $\sqrt{2}b$	0	-Fb+ $\sqrt{2}/2Fx$	0	0	0	0	0	0
BD b	0	-1/2qx ²	0	0	0	0	0+0	0
DB b	0	1/2Fb-Fx+1/2qx ²	0	0	0	0	0	0
DC b	0	-2Fx	0	0	0	0	0+0	0
CD b	0	2Fb-2Fx	0	0	0	0	0	0
CE b	0	-Fb+Fx	0	0	0	0	0+0	0
EC b	0	Fx	0	0	0	0	0	0
FG b	-1/2x/b	-7/4Fx+1/2qx ²	-Fb/EJ	7/8Fx ² /b-1/4qx ³ /b	1/2Fx/EJ	1/4x ² /b ²	(11/48+1/4)Fb ² /EJ	1/12Xb/EJ
GF b	1/2-1/2x/b	5/4Fb-3/4Fx-1/2qx ²	Fb/EJ	5/8Fb-Fx+1/8Fx ² /b+1/4qx ³ /b	1/2Fb/EJ-1/2Fx/EJ	1/4-1/2x/b+1/4x ² /b ²		
GD b	-1+x/b	-1/2Fx	0	1/2Fx-1/2Fx ² /b	0	1-2x/b+x ² /b ²	(1/12+0)Fb ² /EJ	1/3Xb/EJ
DG b	x/b	1/2Fb-1/2Fx	0	1/2Fx-1/2Fx ² /b	0	x ² /b ²		
DH b	0	-Fb+Fx	0	0	0	0	0+0	0
HD b	0	Fx	0	0	0	0	0	0
GA b	1/2-1/2x/b	-5/4Fb+5/4Fx	0	-5/8Fb+5/4Fx-5/8Fx ² /b	0	1/4-1/2x/b+1/4x ² /b ²	(-5/24+0)Fb ² /EJ	1/12Xb/EJ
AG b	-1/2x/b	5/4Fx	0	-5/8Fx ² /b	0	1/4x ² /b ²		
	totali						17/48Fb ² /EJ	1/2Xb/EJ
	iperstatica $X=W_{GD}$						-17/24Fb	

Sviluppi di calcolo iperstatica

$$L_{FG}^{xx} = \int_0^b (1/4 x^2/b^2) 1/EJ dx = [1/12 x^3/b^2]_0^b 1/EJ$$

$$= (1/12 b) 1/EJ = 1/12 b/EJ$$

$$L_{GF}^{xx} = \int_0^b (1/4 - 1/2 x/b + 1/4 x^2/b^2) 1/EJ dx = [1/4 x - 1/4 x^2/b + 1/12 x^3/b^2]_0^b 1/EJ$$

$$= (1/4 b - 1/4 b + 1/12 b) 1/EJ = 1/12 b/EJ$$

$$L_{GD}^{xx} = \int_0^b (1 - 2 x/b + x^2/b^2) 1/EJ dx = [x - x^2/b + 1/3 x^3/b^2]_0^b 1/EJ$$

$$= (b - b + 1/3 b) 1/EJ = 1/3 b/EJ$$

$$L_{DG}^{xx} = \int_0^b (x^2/b^2) 1/EJ dx = [1/3 x^3/b^2]_0^b 1/EJ$$

$$= (1/3 b) 1/EJ = 1/3 b/EJ$$

$$L_{GA}^{xx} = \int_0^b (1/4 - 1/2 x/b + 1/4 x^2/b^2) 1/EJ dx = [1/4 x - 1/4 x^2/b + 1/12 x^3/b^2]_0^b 1/EJ$$

$$= (1/4 b - 1/4 b + 1/12 b) 1/EJ = 1/12 b/EJ$$

$$L_{AG}^{xx} = \int_0^b (1/4 x^2/b^2) 1/EJ dx = [1/12 x^3/b^2]_0^b 1/EJ$$

$$= (1/12 b) 1/EJ = 1/12 b/EJ$$

$$L_{FG}^{xo} = \int_0^b (7/8 x^2/b^2 - 1/4 x^3/b^3) Fb 1/EJ dx + \int_0^b (1/2 x/b) \theta dx$$

$$= [7/24 x^3/b^2 - 1/16 x^4/b^3]_0^b Fb 1/EJ + [1/4 x^2/b]_0^b \theta$$

$$= (7/24 b - 1/16 b) Fb 1/EJ + (1/4 b) \theta = 23/48 Fb^2/EJ$$

$$L_{GF}^{xo} = \int_0^b (5/8 - x/b + 1/8 x^2/b^2 + 1/4 x^3/b^3) Fb 1/EJ dx + \int_0^b (-1/2 + 1/2 x/b) \theta dx$$

$$= [5/8 x - 1/2 x^2/b + 1/24 x^3/b^2 + 1/16 x^4/b^3]_0^b Fb 1/EJ + [-1/2 x + 1/4 x^2/b]_0^b \theta$$

$$= (5/8 b - 1/2 b + 1/24 b + 1/16 b) Fb 1/EJ + (-1/2 b + 1/4 b) \theta = 23/48 Fb^2/EJ$$

$$L_{GD}^{xo} = \int_0^b (1/2 x/b - 1/2 x^2/b^2) Fb 1/EJ dx = [1/4 x^2/b - 1/6 x^3/b^2]_0^b Fb 1/EJ$$

$$= (1/4 b - 1/6 b) Fb 1/EJ = 1/12 Fb^2/EJ$$

$$L_{DG}^{xo} = \int_0^b (1/2 x/b - 1/2 x^2/b^2) Fb 1/EJ dx = [1/4 x^2/b - 1/6 x^3/b^2]_0^b Fb 1/EJ$$

$$= (1/4 b - 1/6 b) Fb 1/EJ = 1/12 Fb^2/EJ$$

$$L_{GA}^{xo} = \int_0^b (-5/8 + 5/4 x/b - 5/8 x^2/b^2) Fb 1/EJ dx = [-5/8 x + 5/8 x^2/b - 5/24 x^3/b^2]_0^b Fb 1/EJ$$

$$= (-5/8 b + 5/8 b - 5/24 b) Fb 1/EJ = -5/24 Fb^2/EJ$$

$$L_{AG}^{xo} = \int_0^b (-5/8 x^2/b^2) Fb 1/EJ dx = [-5/24 x^3/b^2]_0^b Fb 1/EJ$$

$$= (-5/24 b) Fb 1/EJ = -5/24 Fb^2/EJ$$

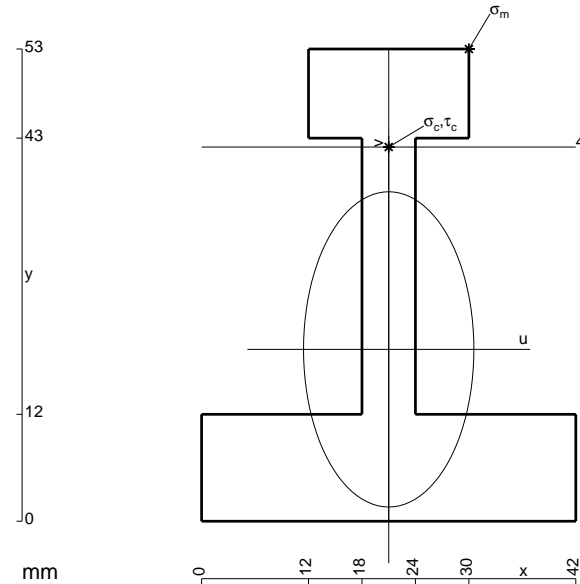

- A = 870. mm²
- J_u = 272367. mm⁴
- J_v = 79506. mm⁴
- y_g = 19.29 mm
- T_y = -2760. N
- M_x = -1932000. Nmm
- x_m = 30. mm
- y_m = 53. mm
- u_m = 9. mm
- v_m = 33.71 mm
- σ_m = -Mv/J_u = 239.1 N/mm²
- x_c = 21. mm
- y_c = 42. mm
- v_c = 22.71 mm
- σ_c = -Mv/J_u = 161.1 N/mm²
- τ_c = 8.964 N/mm²
- σ_o = √σ²+3τ² = 161.9 N/mm²
- S = 5308. mm³

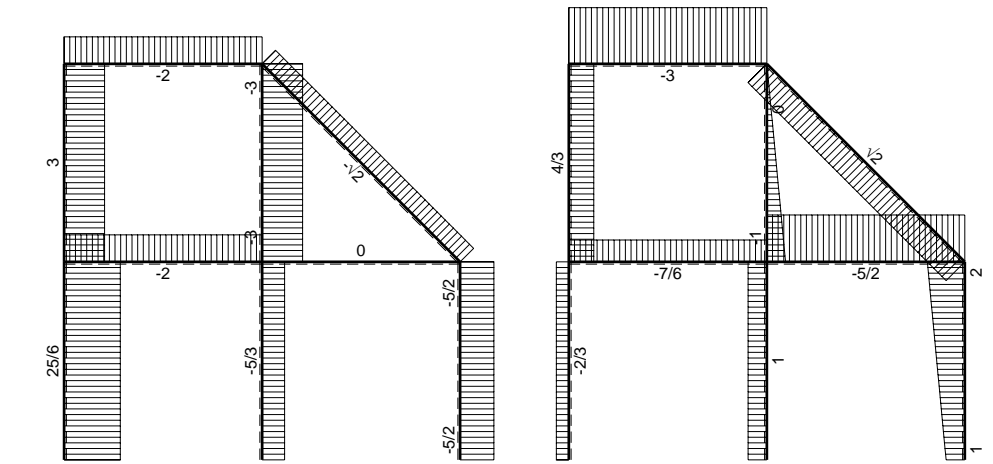
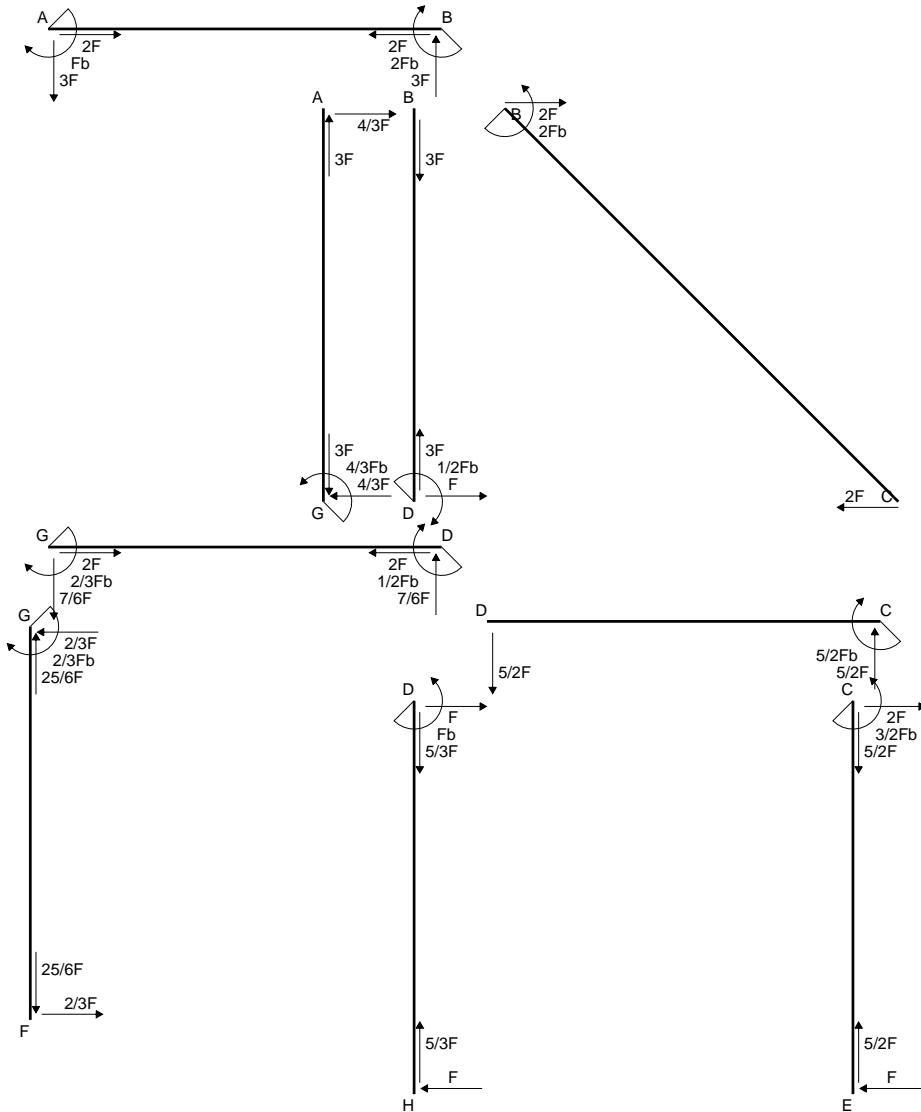

← ⊕ → F

↑ ⊕ ↓ F

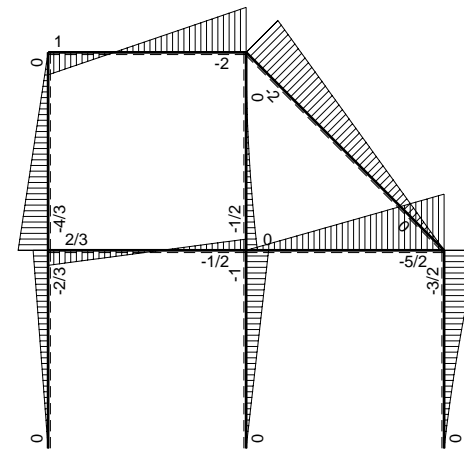

⊕ F_b

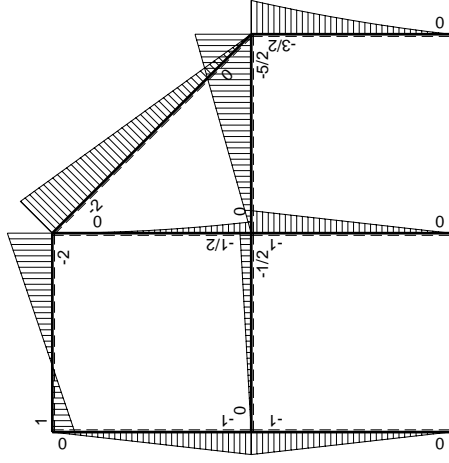
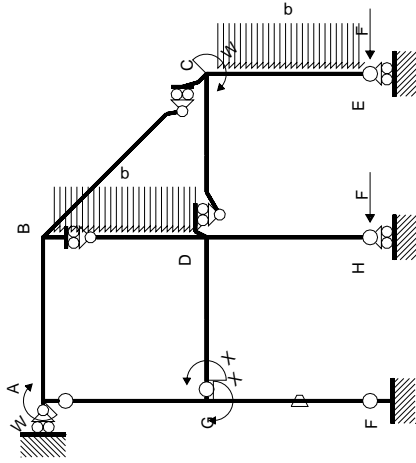

Schema di calcolo iperstatico

M_0 flessione da carichi assegnati

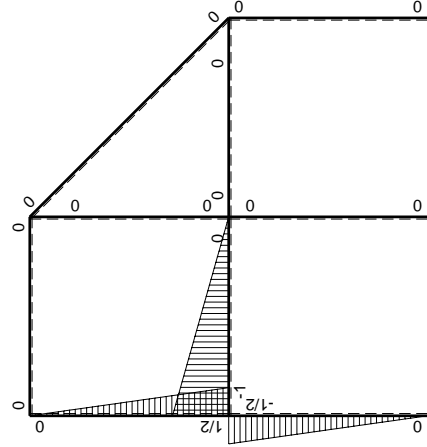

M_X flessione da iperstatica $X=1$

Quadro contributi PLV per iperstatica $X=W_{GD}$

→	$M_x(x)$	$M_o(x)$	θ	$M_x M_o$	$M_x \theta$	$M_x M_x$	$\int M_x(M_o/EJ+\theta)dx$	$\int X M_x M_x / EJ dx$	
AB b	0	Fb-3Fx	0	0	0	0	0+0	0	
BA b	0	2Fb-3Fx	0	0	0	0	0	0	
BC $\sqrt{2}b$	0	-2Fb+ $\sqrt{2}Fx$	0	0	0	0	0	0	
BD b	0	-1/2qx ²	0	0	0	0	0+0	0	
DB b	0	1/2Fb-Fx+1/2qx ²	0	0	0	0	0	0	
DC b	0	-5/2Fx	0	0	0	0	0+0	0	
CD b	0	5/2Fb-5/2Fx	0	0	0	0	0	0	
CE b	0	-3/2Fb+2Fx-1/2qx ²	0	0	0	0	0+0	0	
EC b	0	Fx+1/2qx ²	0	0	0	0	0	0	
FG b	-1/2x/b	-Fx	-Fb/EJ	1/2Fx ² /b	1/2Fx/EJ	1/4x ² /b ²	(1/6+1/4)Fb ² /EJ	1/12Xb/EJ	
GF b	1/2-1/2x/b	Fb-Fx	Fb/EJ	1/2Fb-Fx+1/2Fx ² /b	1/2Fb/EJ-1/2Fx/EJ	1/4-1/2x/b+1/4x ² /b ²			
GD b	-1+x/b	-1/2Fx	0	1/2Fx-1/2Fx ² /b	0	1-2x/b+x ² /b ²	(1/12+0)Fb ² /EJ	1/3Xb/EJ	
DG b	x/b	1/2Fb-1/2Fx	0	1/2Fx-1/2Fx ² /b	0	x ² /b ²			
DH b	0	-Fb+Fx	0	0	0	0	0+0	0	
HD b	0	Fx	0	0	0	0	0	0	
GA b	1/2-1/2x/b	-Fb+Fx	0	-1/2Fb+Fx-1/2Fx ² /b	0	1/4-1/2x/b+1/4x ² /b ²	(-1/6+0)Fb ² /EJ	1/12Xb/EJ	
AG b	-1/2x/b	Fx	0	-1/2Fx ² /b	0	1/4x ² /b ²			
	totali							1/3Fb ² /EJ	1/2Xb/EJ
	iperstatica $X=W_{GD}$							-2/3Fb	

Sviluppi di calcolo iperstatica

$$L_{FG}^{xx} = \int_0^b (1/4 x^2/b^2) 1/EJ dx = [1/12 x^3/b^2]_0^b 1/EJ$$

$$= (1/12 b) 1/EJ = 1/12 b/EJ$$

$$L_{GF}^{xx} = \int_0^b (1/4 - 1/2 x/b + 1/4 x^2/b^2) 1/EJ dx = [1/4 x - 1/4 x^2/b + 1/12 x^3/b^2]_0^b 1/EJ$$

$$= (1/4 b - 1/4 b + 1/12 b) 1/EJ = 1/12 b/EJ$$

$$L_{GD}^{xx} = \int_0^b (1 - 2 x/b + x^2/b^2) 1/EJ dx = [x - x^2/b + 1/3 x^3/b^2]_0^b 1/EJ$$

$$= (b - b + 1/3 b) 1/EJ = 1/3 b/EJ$$

$$L_{DG}^{xx} = \int_0^b (x^2/b^2) 1/EJ dx = [1/3 x^3/b^2]_0^b 1/EJ$$

$$= (1/3 b) 1/EJ = 1/3 b/EJ$$

$$L_{GA}^{xx} = \int_0^b (1/4 - 1/2 x/b + 1/4 x^2/b^2) 1/EJ dx = [1/4 x - 1/4 x^2/b + 1/12 x^3/b^2]_0^b 1/EJ$$

$$= (1/4 b - 1/4 b + 1/12 b) 1/EJ = 1/12 b/EJ$$

$$L_{AG}^{xx} = \int_0^b (1/4 x^2/b^2) 1/EJ dx = [1/12 x^3/b^2]_0^b 1/EJ$$

$$= (1/12 b) 1/EJ = 1/12 b/EJ$$

$$L_{FG}^{xo} = \int_0^b (1/2 x^2/b^2) Fb 1/EJ dx + \int_0^b (1/2 x/b) \theta dx = [1/6 x^3/b^2]_0^b Fb 1/EJ + [1/4 x^2/b]_0^b \theta$$

$$= (1/6 b) Fb 1/EJ + (1/4 b) \theta = 5/12 Fb^2/EJ$$

$$L_{GF}^{xo} = \int_0^b (1/2 - x/b + 1/2 x^2/b^2) Fb 1/EJ dx + \int_0^b (-1/2 + 1/2 x/b) \theta dx$$

$$= [1/2 x - 1/2 x^2/b + 1/6 x^3/b^2]_0^b Fb 1/EJ + [-1/2 x + 1/4 x^2/b]_0^b \theta$$

$$= (1/2 b - 1/2 b + 1/6 b) Fb 1/EJ + (-1/2 b + 1/4 b) \theta = 5/12 Fb^2/EJ$$

$$L_{GD}^{xo} = \int_0^b (1/2 x/b - 1/2 x^2/b^2) Fb 1/EJ dx = [1/4 x^2/b - 1/6 x^3/b^2]_0^b Fb 1/EJ$$

$$= (1/4 b - 1/6 b) Fb 1/EJ = 1/12 Fb^2/EJ$$

$$L_{DG}^{xo} = \int_0^b (1/2 x/b - 1/2 x^2/b^2) Fb 1/EJ dx = [1/4 x^2/b - 1/6 x^3/b^2]_0^b Fb 1/EJ$$

$$= (1/4 b - 1/6 b) Fb 1/EJ = 1/12 Fb^2/EJ$$

$$L_{GA}^{xo} = \int_0^b (-1/2 + x/b - 1/2 x^2/b^2) Fb 1/EJ dx = [-1/2 x + 1/2 x^2/b - 1/6 x^3/b^2]_0^b Fb 1/EJ$$

$$= (-1/2 b + 1/2 b - 1/6 b) Fb 1/EJ = -1/6 Fb^2/EJ$$

$$L_{AG}^{xo} = \int_0^b (-1/2 x^2/b^2) Fb 1/EJ dx = [-1/6 x^3/b^2]_0^b Fb 1/EJ$$

$$= (-1/6 b) Fb 1/EJ = -1/6 Fb^2/EJ$$

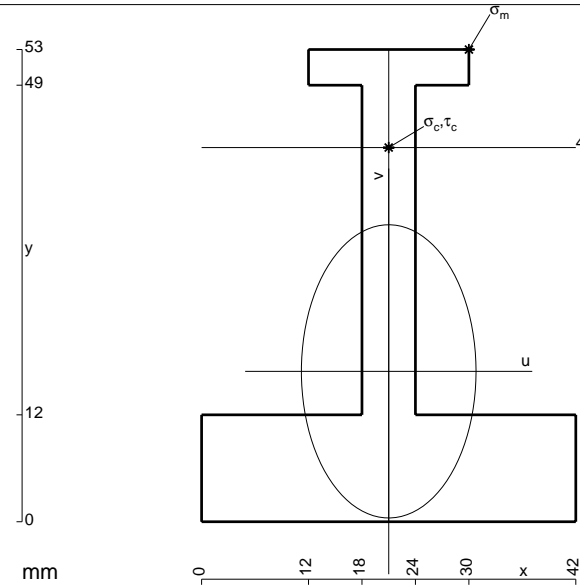

- A = 798. mm²
- J_u = 216134. mm⁴
- J_v = 76698. mm⁴
- y_g = 16.88 mm
- T_y = -1575. N
- M_x = -1181250. Nmm
- x_m = 30. mm
- y_m = 53. mm
- u_m = 9. mm
- v_m = 36.12 mm
- σ_m = -Mv/J_u = 197.4 N/mm²
- x_c = 21. mm
- y_c = 42. mm
- v_c = 25.12 mm
- σ_c = -Mv/J_u = 137.3 N/mm²
- τ_c = 4.444 N/mm²
- σ_q = √σ²+3τ² = 137.5 N/mm²
- S = 3659. mm³

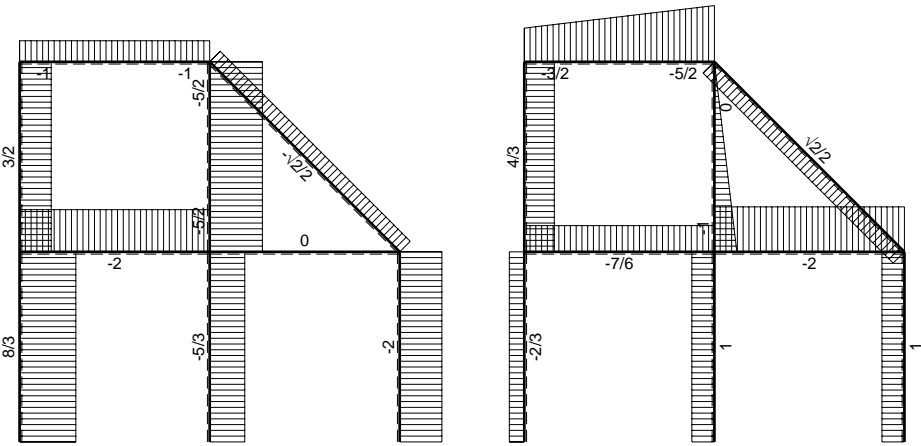
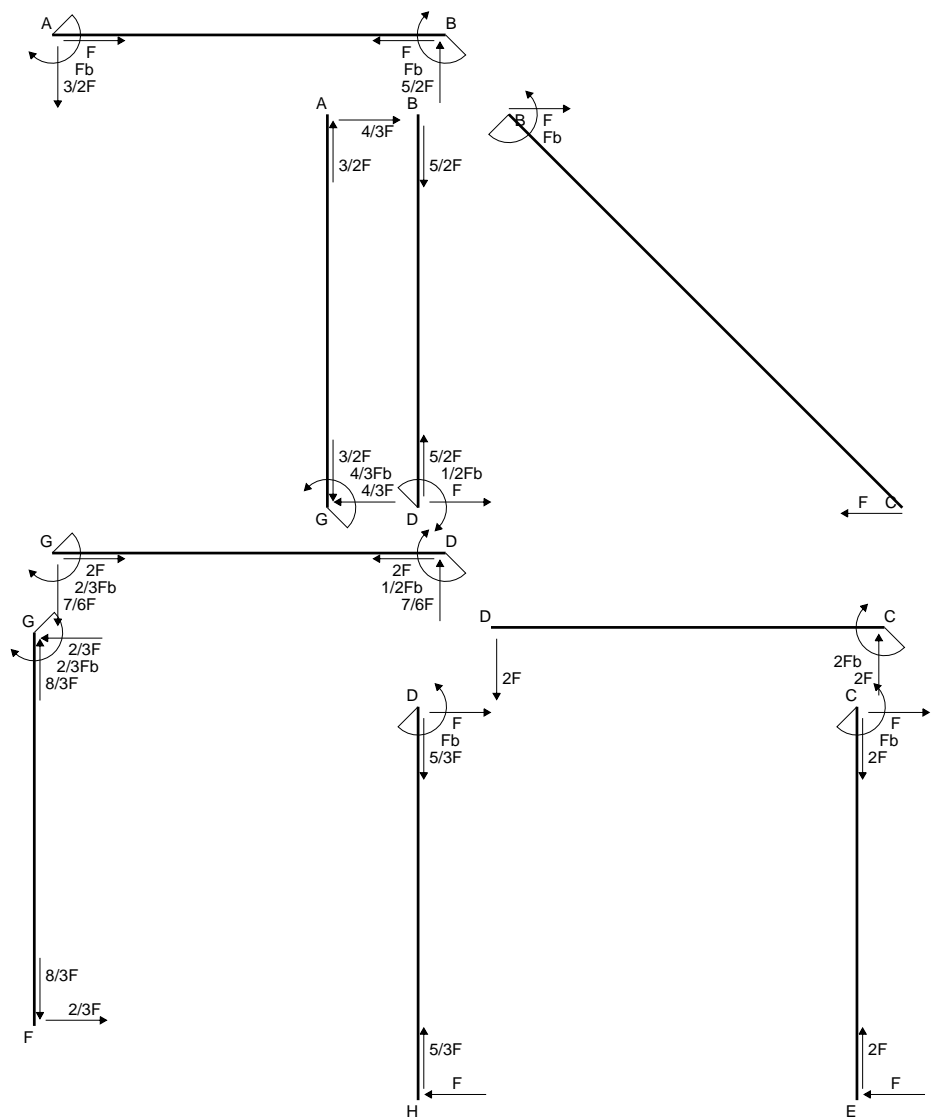

← ⊕ → F

↑ ⊕ ↓ F

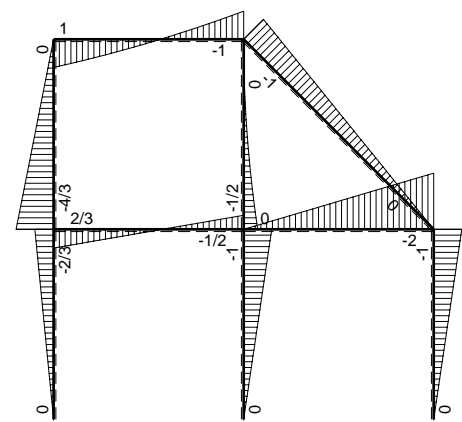

⊕ ⊖ F_b

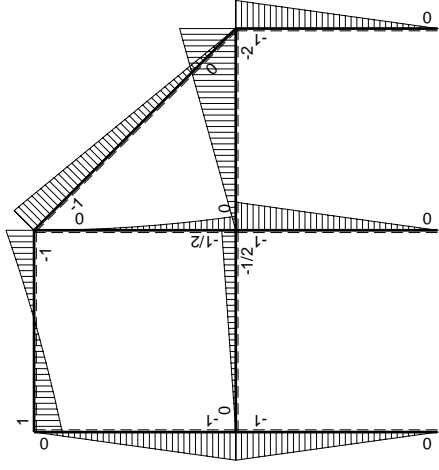
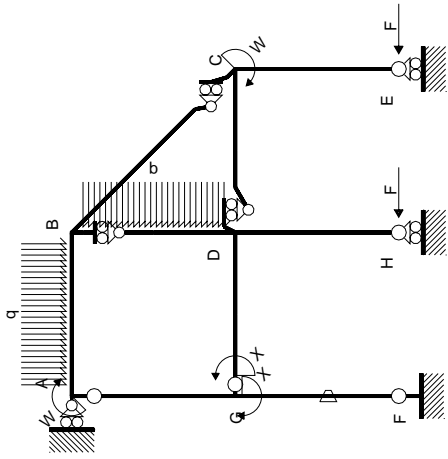

Schema di calcolo iperstatico

M_0 flessione da carichi assegnati

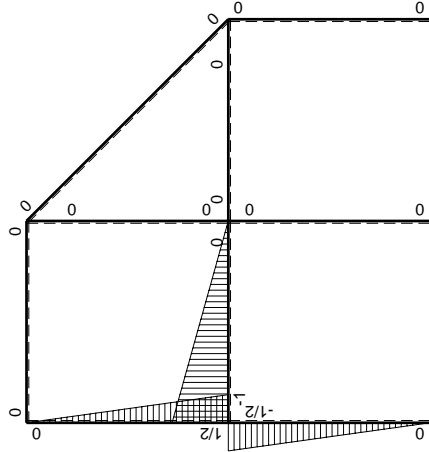

M_x flessione da iperstatica $X=1$

Quadro contributi PLV per iperstatica $X=W_{GD}$

→	$M_x(x)$	$M_o(x)$	θ	$M_x M_o$	$M_x \theta$	$M_x M_x$	$\int M_x(M_o/EJ+\theta)dx$	$\int X M_x M_x / EJ dx$
AB b	0	$Fb-3/2Fx-1/2qx^2$	0	0	0	0	0+0	0
BA b	0	$Fb-5/2Fx+1/2qx^2$	0	0	0	0	0	0
BC $\sqrt{2}b$	0	$-Fb+\sqrt{2}/2Fx$	0	0	0	0	0	0
BD b	0	$-1/2qx^2$	0	0	0	0	0+0	0
DB b	0	$1/2Fb-Fx+1/2qx^2$	0	0	0	0	0	0
DC b	0	$-2Fx$	0	0	0	0	0+0	0
CD b	0	$2Fb-2Fx$	0	0	0	0	0	0
CE b	0	$-Fb+Fx$	0	0	0	0	0+0	0
EC b	0	Fx	0	0	0	0	0	0
FG b	$-1/2x/b$	$-Fx$	$-Fb/EJ$	$1/2Fx^2/b$	$1/2Fx/EJ$	$1/4x^2/b^2$	$(1/6+1/4)Fb^2/EJ$	$1/12Xb/EJ$
GF b	$1/2-1/2x/b$	$Fb-Fx$	Fb/EJ	$1/2Fb-Fx+1/2Fx^2/b$	$1/2Fb/EJ-1/2Fx/EJ$	$1/4-1/2x/b+1/4x^2/b^2$		
GD b	$-1+x/b$	$-1/2Fx$	0	$1/2Fx-1/2Fx^2/b$	0	$1-2x/b+x^2/b^2$	$(1/12+0)Fb^2/EJ$	$1/3Xb/EJ$
DG b	x/b	$1/2Fb-1/2Fx$	0	$1/2Fx-1/2Fx^2/b$	0	x^2/b^2		
DH b	0	$-Fb+Fx$	0	0	0	0	0+0	0
HD b	0	Fx	0	0	0	0	0	0
GA b	$1/2-1/2x/b$	$-Fb+Fx$	0	$-1/2Fb+Fx-1/2Fx^2/b$	0	$1/4-1/2x/b+1/4x^2/b^2$	$(-1/6+0)Fb^2/EJ$	$1/12Xb/EJ$
AG b	$-1/2x/b$	Fx	0	$-1/2Fx^2/b$	0	$1/4x^2/b^2$		
	totali						$1/3Fb^2/EJ$	$1/2Xb/EJ$
	iperstatica $X=W_{GD}$						$-2/3Fb$	

Sviluppi di calcolo iperstatica

$$L_{FG}^{xx} = \int_0^b (1/4 x^2/b^2) 1/EJ dx = [1/12 x^3/b^2]_0^b 1/EJ$$

$$= (1/12 b) 1/EJ = 1/12 b/EJ$$

$$L_{GF}^{xx} = \int_0^b (1/4 - 1/2 x/b + 1/4 x^2/b^2) 1/EJ dx = [1/4 x - 1/4 x^2/b + 1/12 x^3/b^2]_0^b 1/EJ$$

$$= (1/4 b - 1/4 b + 1/12 b) 1/EJ = 1/12 b/EJ$$

$$L_{GD}^{xx} = \int_0^b (1 - 2 x/b + x^2/b^2) 1/EJ dx = [x - x^2/b + 1/3 x^3/b^2]_0^b 1/EJ$$

$$= (b - b + 1/3 b) 1/EJ = 1/3 b/EJ$$

$$L_{DG}^{xx} = \int_0^b (x^2/b^2) 1/EJ dx = [1/3 x^3/b^2]_0^b 1/EJ$$

$$= (1/3 b) 1/EJ = 1/3 b/EJ$$

$$L_{GA}^{xx} = \int_0^b (1/4 - 1/2 x/b + 1/4 x^2/b^2) 1/EJ dx = [1/4 x - 1/4 x^2/b + 1/12 x^3/b^2]_0^b 1/EJ$$

$$= (1/4 b - 1/4 b + 1/12 b) 1/EJ = 1/12 b/EJ$$

$$L_{AG}^{xx} = \int_0^b (1/4 x^2/b^2) 1/EJ dx = [1/12 x^3/b^2]_0^b 1/EJ$$

$$= (1/12 b) 1/EJ = 1/12 b/EJ$$

$$L_{FG}^{xo} = \int_0^b (1/2 x^2/b^2) Fb 1/EJ dx + \int_0^b (1/2 x/b) \theta dx = [1/6 x^3/b^2]_0^b Fb 1/EJ + [1/4 x^2/b]_0^b \theta$$

$$= (1/6 b) Fb 1/EJ + (1/4 b) \theta = 5/12 Fb^2/EJ$$

$$L_{GF}^{xo} = \int_0^b (1/2 - x/b + 1/2 x^2/b^2) Fb 1/EJ dx + \int_0^b (-1/2 + 1/2 x/b) \theta dx$$

$$= [1/2 x - 1/2 x^2/b + 1/6 x^3/b^2]_0^b Fb 1/EJ + [-1/2 x + 1/4 x^2/b]_0^b \theta$$

$$= (1/2 b - 1/2 b + 1/6 b) Fb 1/EJ + (-1/2 b + 1/4 b) \theta = 5/12 Fb^2/EJ$$

$$L_{GD}^{xo} = \int_0^b (1/2 x/b - 1/2 x^2/b^2) Fb 1/EJ dx = [1/4 x^2/b - 1/6 x^3/b^2]_0^b Fb 1/EJ$$

$$= (1/4 b - 1/6 b) Fb 1/EJ = 1/12 Fb^2/EJ$$

$$L_{DG}^{xo} = \int_0^b (1/2 x/b - 1/2 x^2/b^2) Fb 1/EJ dx = [1/4 x^2/b - 1/6 x^3/b^2]_0^b Fb 1/EJ$$

$$= (1/4 b - 1/6 b) Fb 1/EJ = 1/12 Fb^2/EJ$$

$$L_{GA}^{xo} = \int_0^b (-1/2 + x/b - 1/2 x^2/b^2) Fb 1/EJ dx = [-1/2 x + 1/2 x^2/b - 1/6 x^3/b^2]_0^b Fb 1/EJ$$

$$= (-1/2 b + 1/2 b - 1/6 b) Fb 1/EJ = -1/6 Fb^2/EJ$$

$$L_{AG}^{xo} = \int_0^b (-1/2 x^2/b^2) Fb 1/EJ dx = [-1/6 x^3/b^2]_0^b Fb 1/EJ$$

$$= (-1/6 b) Fb 1/EJ = -1/6 Fb^2/EJ$$

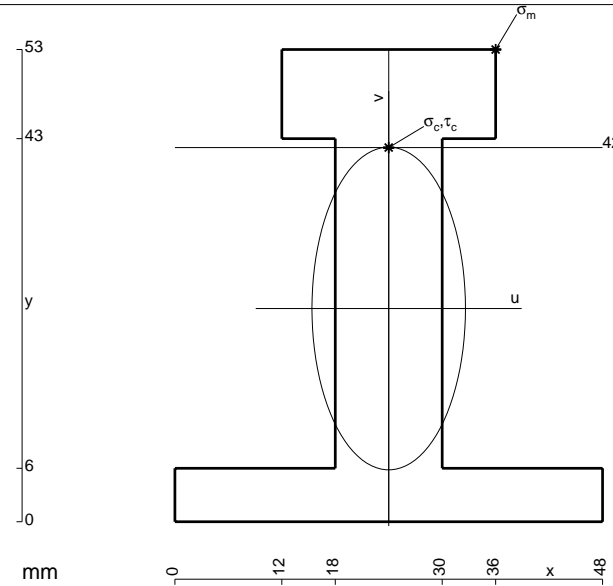

- A = 972. mm²
- J_u = 318872. mm⁴
- J_v = 72144. mm⁴
- y_g = 23.93 mm
- T_y = -2860. N
- M_x = -2288000. Nmm
- x_m = 36. mm
- y_m = 53. mm
- u_m = 12. mm
- v_m = 29.07 mm
- σ_m = -M_v/J_u = 208.6 N/mm²
- x_c = 24. mm
- y_c = 42. mm
- v_c = 18.07 mm
- σ_c = -M_v/J_u = 129.6 N/mm²
- τ_c = 4.484 N/mm²
- σ_q = √σ²+3τ² = 129.9 N/mm²
- S = 5999. mm³

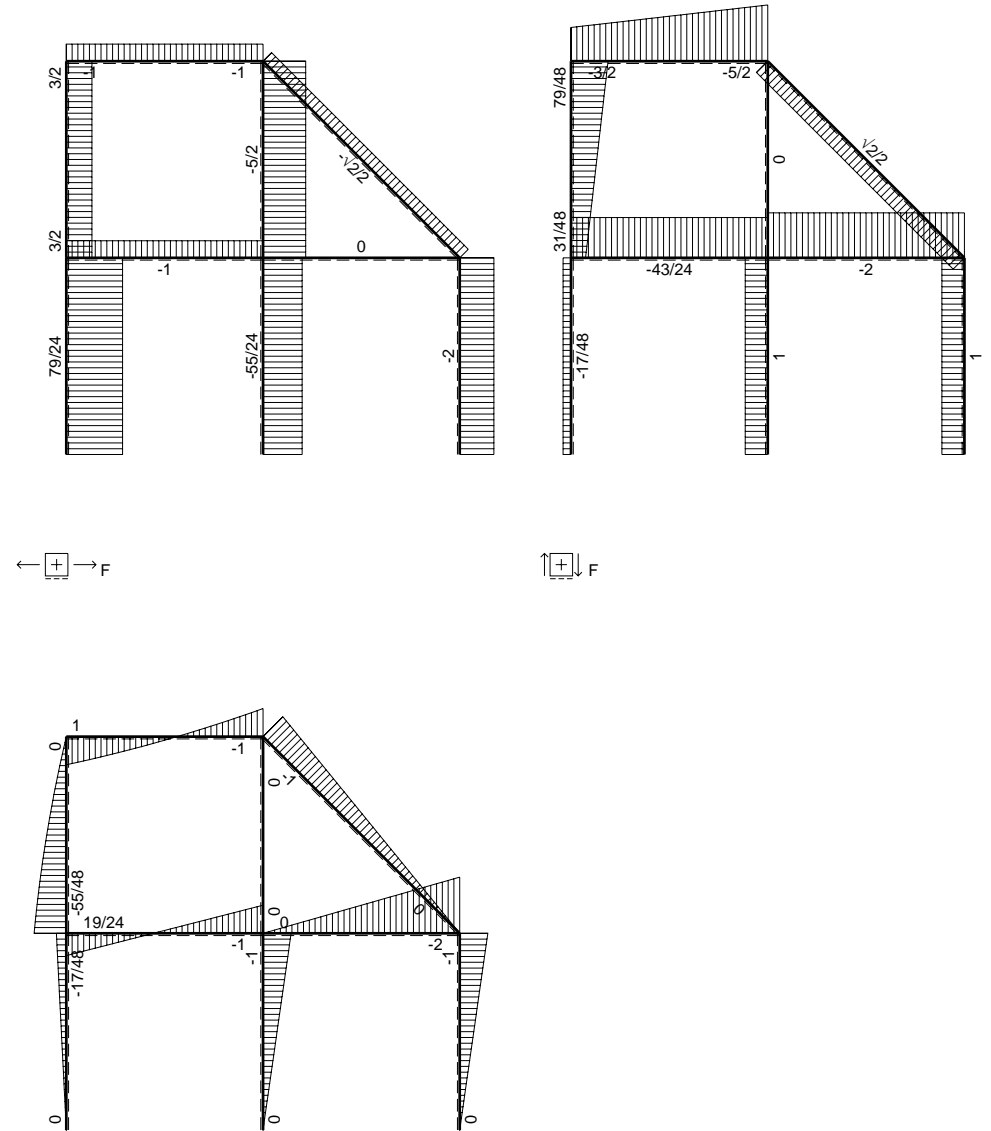
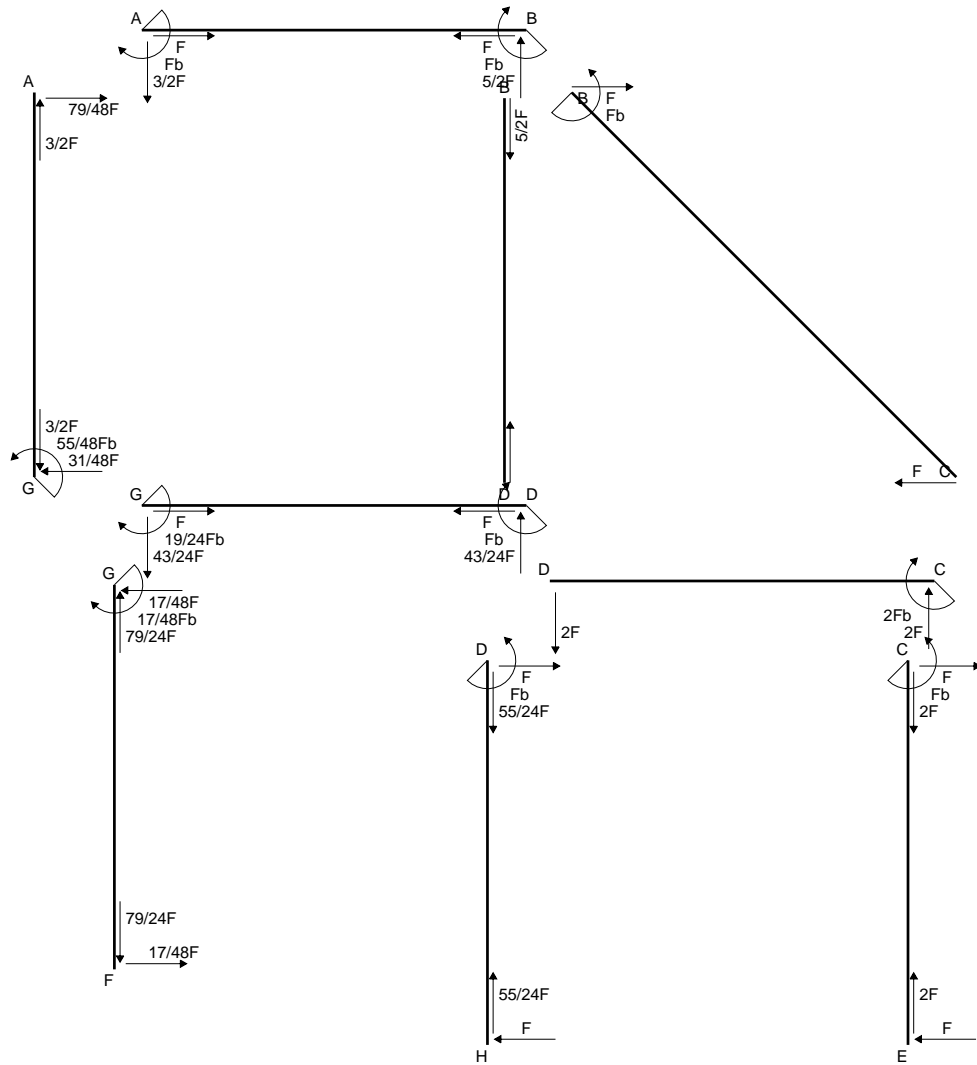

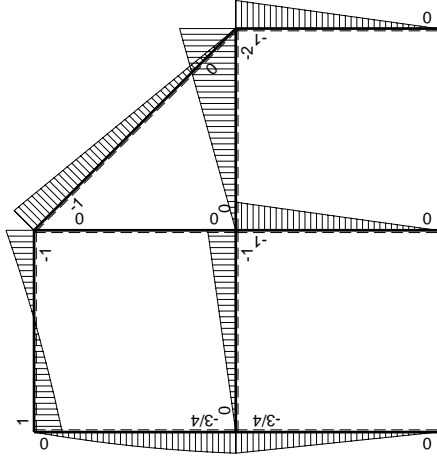
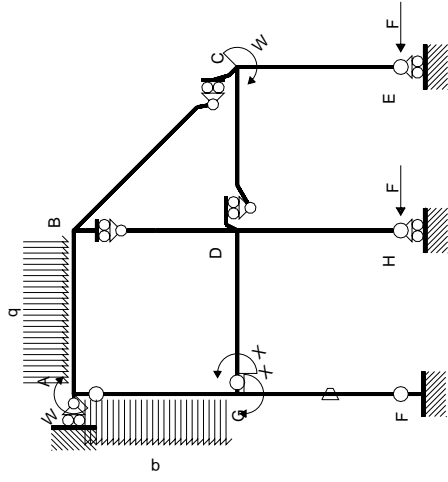

Schema di calcolo iperstatico

M_0 flessione da carichi assegnati

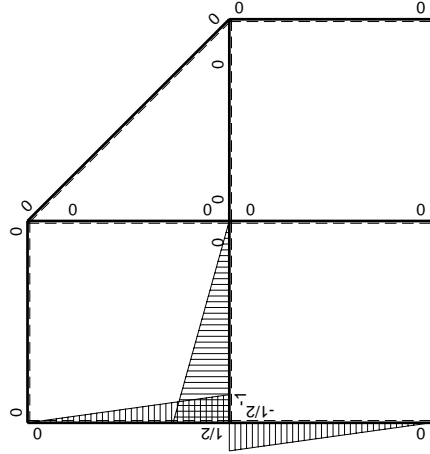

M_x flessione da iperstatica $X=1$

Quadro contributi PLV per iperstatica $X=W_{GD}$

→	$M_x(x)$	$M_o(x)$	θ	$M_x M_o$	$M_x \theta$	$M_x M_x$	$\int M_x(M_o/EJ+\theta)dx$	$\int X M_x M_x/EJ dx$	
AB b	0	$Fb-3/2Fx-1/2qx^2$	0	0	0	0	0+0	0	
BA b	0	$Fb-5/2Fx+1/2qx^2$	0	0	0	0	0	0	
BC $\sqrt{2}b$	0	$-Fb+\sqrt{2}/2Fx$	0	0	0	0	0	0	
BD b	0	0	0	0	0	0	0+0	0	
DB b	0	0	0	0	0	0	0	0	
DC b	0	$-2Fx$	0	0	0	0	0+0	0	
CD b	0	$2Fb-2Fx$	0	0	0	0	0	0	
CE b	0	$-Fb+Fx$	0	0	0	0	0+0	0	
EC b	0	Fx	0	0	0	0	0	0	
FG b	$-1/2x/b$	$-3/4Fx$	$-Fb/EJ$	$3/8Fx^2/b$	$1/2Fx/EJ$	$1/4x^2/b^2$	$(1/8+1/4)Fb^2/EJ$	$1/12Xb/EJ$	
GF b	$1/2-1/2x/b$	$3/4Fb-3/4Fx$	Fb/EJ	$3/8Fb-3/4Fx+3/8Fx^2/b$	$1/2Fb/EJ-1/2Fx/EJ$	$1/4-1/2x/b+1/4x^2/b^2$			
GD b	$-1+x/b$	$-Fx$	0	$Fx-Fx^2/b$	0	$1-2x/b+x^2/b^2$	$(1/6+0)Fb^2/EJ$	$1/3Xb/EJ$	
DG b	x/b	$Fb-Fx$	0	$Fx-Fx^2/b$	0	x^2/b^2			
DH b	0	$-Fb+Fx$	0	0	0	0	0+0	0	
HD b	0	Fx	0	0	0	0			
GA b	$1/2-1/2x/b$	$-3/4Fb+1/4Fx+1/2qx^2$	0	$-3/8Fb+1/2Fx+1/8Fx^2/b-1/4qx^3/b$	0	$1/4-1/2x/b+1/4x^2/b^2$	$(-7/48+0)Fb^2/EJ$	$1/12Xb/EJ$	
AG b	$-1/2x/b$	$5/4Fx-1/2qx^2$	0	$-5/8Fx^2/b+1/4qx^3/b$	0	$1/4x^2/b^2$			
	totali							$19/48Fb^2/EJ$	$1/2Xb/EJ$
	iperstatica $X=W_{GD}$							$-19/24Fb$	

Sviluppi di calcolo iperstatica

$$L_{FG}^{xx} = \int_0^b (1/4 x^2/b^2) 1/EJ dx = [1/12 x^3/b^2]_0^b 1/EJ$$

$$= (1/12 b) 1/EJ = 1/12 b/EJ$$

$$L_{GF}^{xx} = \int_0^b (1/4 - 1/2 x/b + 1/4 x^2/b^2) 1/EJ dx = [1/4 x - 1/4 x^2/b + 1/12 x^3/b^2]_0^b 1/EJ$$

$$= (1/4 b - 1/4 b + 1/12 b) 1/EJ = 1/12 b/EJ$$

$$L_{GD}^{xx} = \int_0^b (1 - 2 x/b + x^2/b^2) 1/EJ dx = [x - x^2/b + 1/3 x^3/b^2]_0^b 1/EJ$$

$$= (b - b + 1/3 b) 1/EJ = 1/3 b/EJ$$

$$L_{DG}^{xx} = \int_0^b (x^2/b^2) 1/EJ dx = [1/3 x^3/b^2]_0^b 1/EJ$$

$$= (1/3 b) 1/EJ = 1/3 b/EJ$$

$$L_{GA}^{xx} = \int_0^b (1/4 - 1/2 x/b + 1/4 x^2/b^2) 1/EJ dx = [1/4 x - 1/4 x^2/b + 1/12 x^3/b^2]_0^b 1/EJ$$

$$= (1/4 b - 1/4 b + 1/12 b) 1/EJ = 1/12 b/EJ$$

$$L_{AG}^{xx} = \int_0^b (1/4 x^2/b^2) 1/EJ dx = [1/12 x^3/b^2]_0^b 1/EJ$$

$$= (1/12 b) 1/EJ = 1/12 b/EJ$$

$$L_{FG}^{xo} = \int_0^b (3/8 x^2/b^2) Fb 1/EJ dx + \int_0^b (1/2 x/b) \theta dx = [1/8 x^3/b^2]_0^b Fb 1/EJ + [1/4 x^2/b]_0^b \theta$$

$$= (1/8 b) Fb 1/EJ + (1/4 b) \theta = 3/8 Fb^2/EJ$$

$$L_{GF}^{xo} = \int_0^b (3/8 - 3/4 x/b + 3/8 x^2/b^2) Fb 1/EJ dx + \int_0^b (-1/2 + 1/2 x/b) \theta dx$$

$$= [3/8 x - 3/8 x^2/b + 1/8 x^3/b^2]_0^b Fb 1/EJ + [-1/2 x + 1/4 x^2/b]_0^b \theta$$

$$= (3/8 b - 3/8 b + 1/8 b) Fb 1/EJ + (-1/2 b + 1/4 b) \theta = 3/8 Fb^2/EJ$$

$$L_{GD}^{xo} = \int_0^b (x/b - x^2/b^2) Fb 1/EJ dx = [1/2 x^2/b - 1/3 x^3/b^2]_0^b Fb 1/EJ$$

$$= (1/2 b - 1/3 b) Fb 1/EJ = 1/6 Fb^2/EJ$$

$$L_{DG}^{xo} = \int_0^b (x/b - x^2/b^2) Fb 1/EJ dx = [1/2 x^2/b - 1/3 x^3/b^2]_0^b Fb 1/EJ$$

$$= (1/2 b - 1/3 b) Fb 1/EJ = 1/6 Fb^2/EJ$$

$$L_{GA}^{xo} = \int_0^b (-3/8 + 1/2 x/b + 1/8 x^2/b^2 - 1/4 x^3/b^3) Fb 1/EJ dx$$

$$= [-3/8 x + 1/4 x^2/b + 1/24 x^3/b^2 - 1/16 x^4/b^3]_0^b Fb 1/EJ$$

$$= (-3/8 b + 1/4 b + 1/24 b - 1/16 b) Fb 1/EJ = -7/48 Fb^2/EJ$$

$$L_{AG}^{xo} = \int_0^b (-5/8 x^2/b^2 + 1/4 x^3/b^3) Fb 1/EJ dx = [-5/24 x^3/b^2 + 1/16 x^4/b^3]_0^b Fb 1/EJ$$

$$= (-5/24 b + 1/16 b) Fb 1/EJ = -7/48 Fb^2/EJ$$

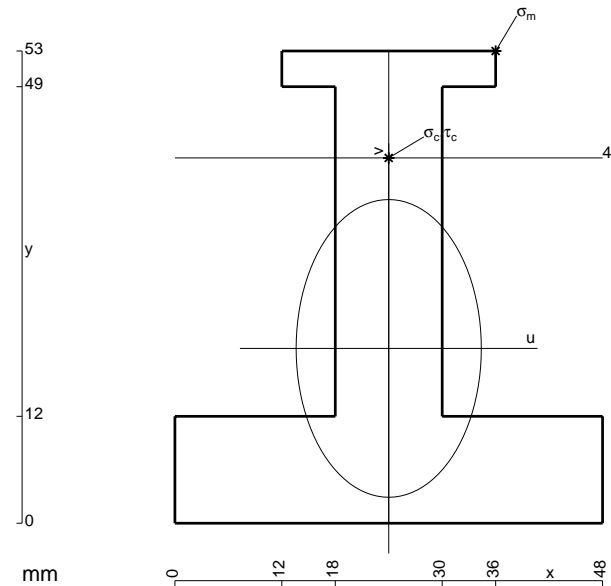

$$A = 1116. \text{ mm}^2$$

$$J_u = 311633. \text{ mm}^4$$

$$J_v = 120528. \text{ mm}^4$$

$$y_g = 19.62 \text{ mm}$$

$$T_y = -2400. \text{ N}$$

$$M_x = -2040000. \text{ Nmm}$$

$$x_m = 36. \text{ mm}$$

$$y_m = 53. \text{ mm}$$

$$u_m = 12. \text{ mm}$$

$$v_m = 33.38 \text{ mm}$$

$$\sigma_m = -Mv/J_u = 218.5 \text{ N/mm}^2$$

$$x_c = 24. \text{ mm}$$

$$y_c = 41. \text{ mm}$$

$$v_c = 21.38 \text{ mm}$$

$$\sigma_c = -Mv/J_u = 140. \text{ N/mm}^2$$

$$\tau_c = 3.497 \text{ N/mm}^2$$

$$\sigma_o = \sqrt{\sigma^2 + 3\tau^2} = 140.1 \text{ N/mm}^2$$

$$S = 5449. \text{ mm}^3$$

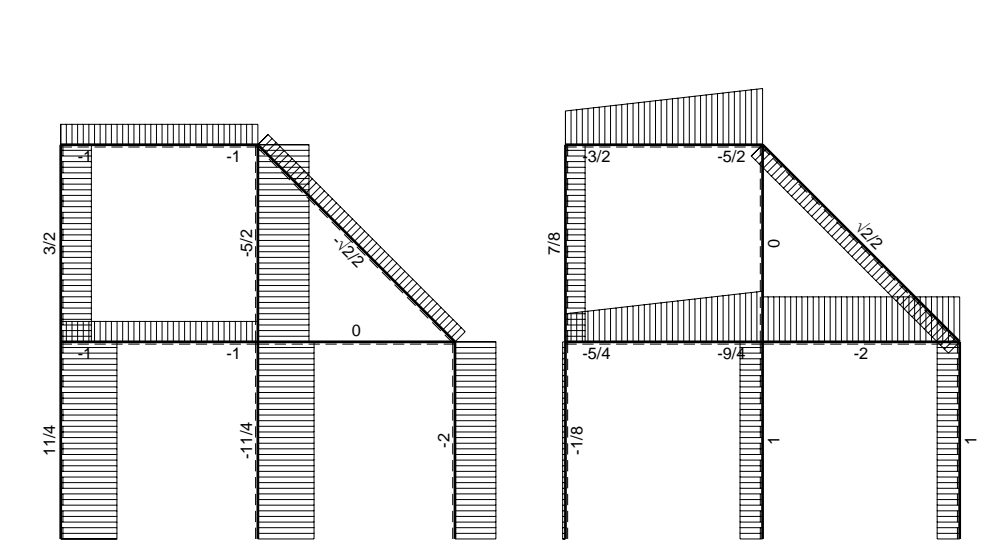
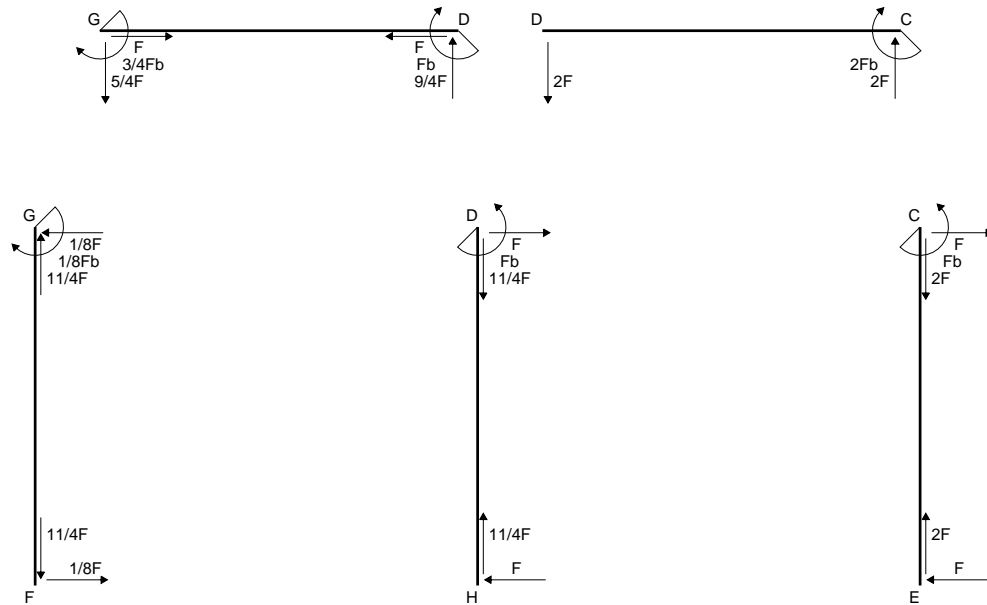
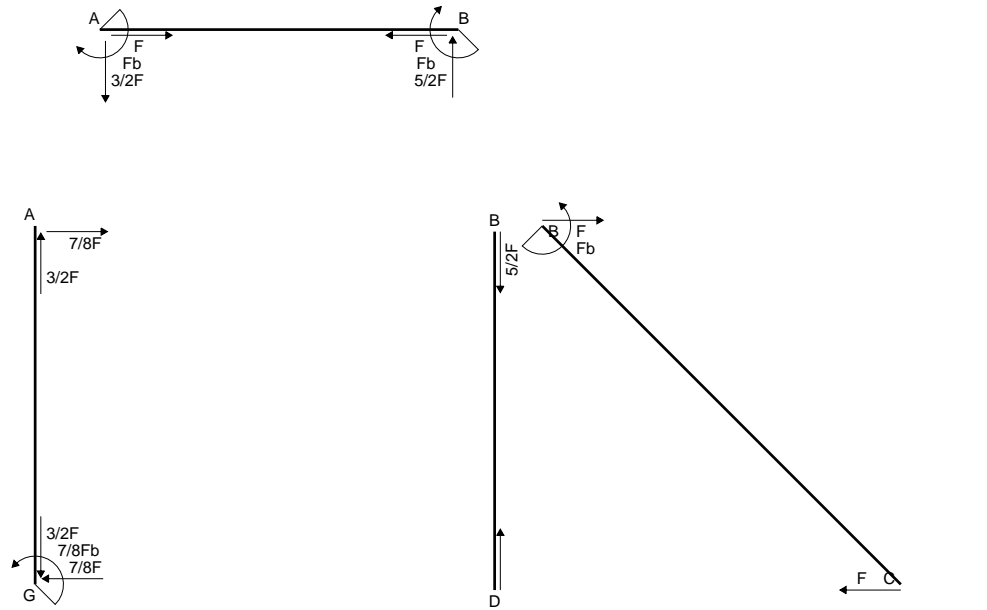

← ⊕ → F

↑ ⊕ ↓ F

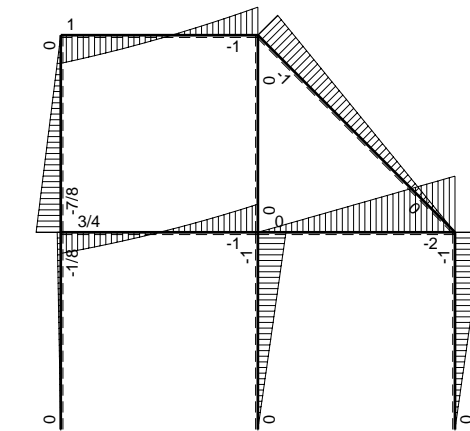

⊕ ⊖ Fb

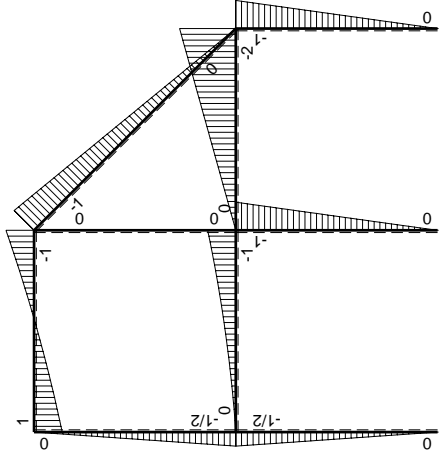
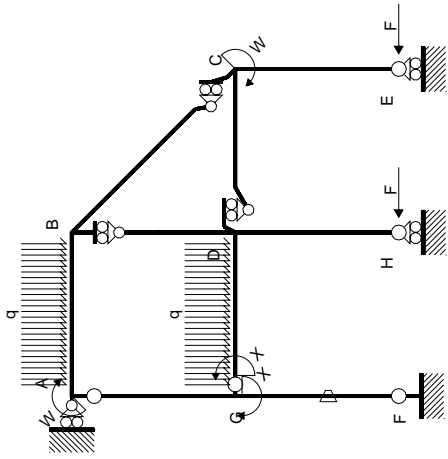

Schema di calcolo iperstatico

M_0 flessione da carichi assegnati

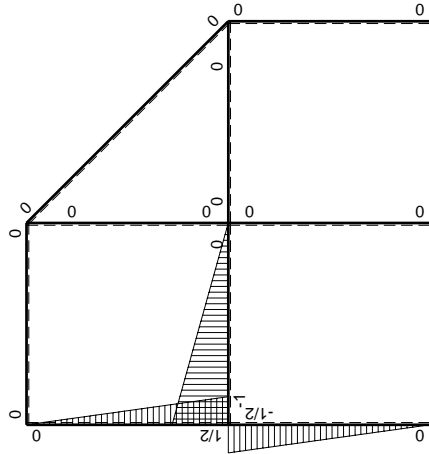

M_x flessione da iperstatica $X=1$

Quadro contributi PLV per iperstatica $X=W_{GD}$

→	$M_x(x)$	$M_o(x)$	θ	$M_x M_o$	$M_x \theta$	$M_x M_x$	$\int M_x(M_o/EJ+\theta)dx$	$\int X M_x M_x/EJdx$
AB b	0	$Fb-3/2Fx-1/2qx^2$	0	0	0	0	0+0	0
BA b	0	$Fb-5/2Fx+1/2qx^2$	0	0	0	0	0	0
BC $\sqrt{2}b$	0	$-Fb+\sqrt{2}/2Fx$	0	0	0	0	0	0
BD b	0	0	0	0	0	0	0+0	0
DB b	0	0	0	0	0	0	0	0
DC b	0	$-2Fx$	0	0	0	0	0+0	0
CD b	0	$2Fb-2Fx$	0	0	0	0	0	0
CE b	0	$-Fb+Fx$	0	0	0	0	0+0	0
EC b	0	Fx	0	0	0	0	0	0
FG b	$-1/2x/b$	$-1/2Fx$	$-Fb/EJ$	$1/4Fx^2/b$	$1/2Fx/EJ$	$1/4x^2/b^2$	$(1/12+1/4)Fb^2/EJ$	$1/12Xb/EJ$
GF b	$1/2-1/2x/b$	$1/2Fb-1/2Fx$	Fb/EJ	$1/4Fb-1/2Fx+1/4Fx^2/b$	$1/2Fb/EJ-1/2Fx/EJ$	$1/4-1/2x/b+1/4x^2/b^2$		
GD b	$-1+x/b$	$-1/2Fx-1/2qx^2$	0	$1/2Fx-1/2qx^3/b$	0	$1-2x/b+x^2/b^2$	$(1/8+0)Fb^2/EJ$	$1/3Xb/EJ$
DG b	x/b	$Fb-3/2Fx+1/2qx^2$	0	$Fx-3/2Fx^2/b+1/2qx^3/b$	0	x^2/b^2		
DH b	0	$-Fb+Fx$	0	0	0	0	0+0	0
HD b	0	Fx	0	0	0	0	0	0
GA b	$1/2-1/2x/b$	$-1/2Fb+1/2Fx$	0	$-1/4Fb+1/2Fx-1/4Fx^2/b$	0	$1/4-1/2x/b+1/4x^2/b^2$	$(-1/12+0)Fb^2/EJ$	$1/12Xb/EJ$
AG b	$-1/2x/b$	$1/2Fx$	0	$-1/4Fx^2/b$	0	$1/4x^2/b^2$		
	totali						$3/8Fb^2/EJ$	$1/2Xb/EJ$
	iperstatica $X=W_{GD}$						$-3/4Fb$	

Sviluppi di calcolo iperstatica

$$L_{FG}^{xx} = \int_0^b (1/4 x^2/b^2) 1/EJ dx = [1/12 x^3/b^2]_0^b 1/EJ$$

$$= (1/12 b) 1/EJ = 1/12 b/EJ$$

$$L_{GF}^{xx} = \int_0^b (1/4 - 1/2 x/b + 1/4 x^2/b^2) 1/EJ dx = [1/4 x - 1/4 x^2/b + 1/12 x^3/b^2]_0^b 1/EJ$$

$$= (1/4 b - 1/4 b + 1/12 b) 1/EJ = 1/12 b/EJ$$

$$L_{GD}^{xx} = \int_0^b (1 - 2 x/b + x^2/b^2) 1/EJ dx = [x - x^2/b + 1/3 x^3/b^2]_0^b 1/EJ$$

$$= (b - b + 1/3 b) 1/EJ = 1/3 b/EJ$$

$$L_{DG}^{xx} = \int_0^b (x^2/b^2) 1/EJ dx = [1/3 x^3/b^2]_0^b 1/EJ$$

$$= (1/3 b) 1/EJ = 1/3 b/EJ$$

$$L_{GA}^{xx} = \int_0^b (1/4 - 1/2 x/b + 1/4 x^2/b^2) 1/EJ dx = [1/4 x - 1/4 x^2/b + 1/12 x^3/b^2]_0^b 1/EJ$$

$$= (1/4 b - 1/4 b + 1/12 b) 1/EJ = 1/12 b/EJ$$

$$L_{AG}^{xx} = \int_0^b (1/4 x^2/b^2) 1/EJ dx = [1/12 x^3/b^2]_0^b 1/EJ$$

$$= (1/12 b) 1/EJ = 1/12 b/EJ$$

$$L_{FG}^{xo} = \int_0^b (1/4 x^2/b^2) Fb 1/EJ dx + \int_0^b (1/2 x/b) \theta dx = [1/12 x^3/b^2]_0^b Fb 1/EJ + [1/4 x^2/b]_0^b \theta$$

$$= (1/12 b) Fb 1/EJ + (1/4 b) \theta = 1/3 Fb^2/EJ$$

$$L_{GF}^{xo} = \int_0^b (1/4 - 1/2 x/b + 1/4 x^2/b^2) Fb 1/EJ dx + \int_0^b (-1/2 + 1/2 x/b) \theta dx$$

$$= [1/4 x - 1/4 x^2/b + 1/12 x^3/b^2]_0^b Fb 1/EJ + [-1/2 x + 1/4 x^2/b]_0^b \theta$$

$$= (1/4 b - 1/4 b + 1/12 b) Fb 1/EJ + (-1/2 b + 1/4 b) \theta = 1/3 Fb^2/EJ$$

$$L_{GD}^{xo} = \int_0^b (1/2 x/b - 1/2 x^3/b^3) Fb 1/EJ dx = [1/4 x^2/b - 1/8 x^4/b^3]_0^b Fb 1/EJ$$

$$= (1/4 b - 1/8 b) Fb 1/EJ = 1/8 Fb^2/EJ$$

$$L_{DG}^{xo} = \int_0^b (x/b - 3/2 x^2/b^2 + 1/2 x^3/b^3) Fb 1/EJ dx = [1/2 x^2/b - 1/2 x^3/b^2 + 1/8 x^4/b^3]_0^b Fb 1/EJ$$

$$= (1/2 b - 1/2 b + 1/8 b) Fb 1/EJ = 1/8 Fb^2/EJ$$

$$L_{GA}^{xo} = \int_0^b (-1/4 + 1/2 x/b - 1/4 x^2/b^2) Fb 1/EJ dx = [-1/4 x + 1/4 x^2/b - 1/12 x^3/b^2]_0^b Fb 1/EJ$$

$$= (-1/4 b + 1/4 b - 1/12 b) Fb 1/EJ = -1/12 Fb^2/EJ$$

$$L_{AG}^{xo} = \int_0^b (-1/4 x^2/b^2) Fb 1/EJ dx = [-1/12 x^3/b^2]_0^b Fb 1/EJ$$

$$= (-1/12 b) Fb 1/EJ = -1/12 Fb^2/EJ$$

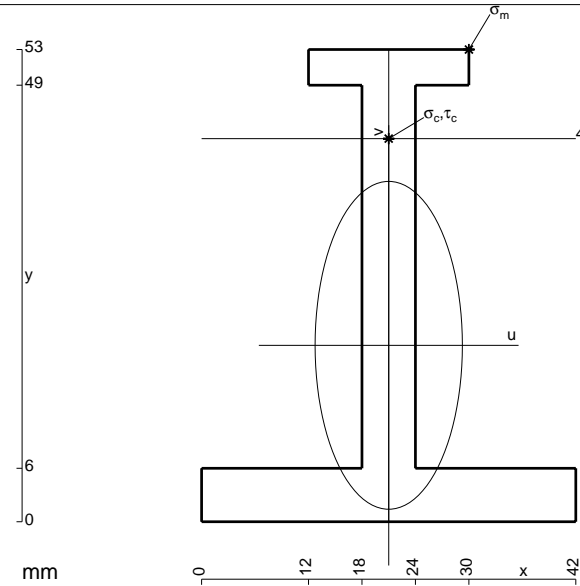

- A = 582. mm²
- J_u = 197114. mm⁴
- J_v = 39762. mm⁴
- y_g = 19.8 mm
- T_y = -1500. N
- M_x = -1350000. Nmm
- x_m = 30. mm
- y_m = 53. mm
- u_m = 9. mm
- v_m = 33.2 mm
- σ_m = -Mv/J_u = 227.4 N/mm²
- x_c = 21. mm
- y_c = 43. mm
- v_c = 23.2 mm
- σ_c = -Mv/J_u = 158.9 N/mm²
- τ_c = 4.046 N/mm²
- σ_q = √σ²+3τ² = 159.1 N/mm²
- S = 3190. mm³

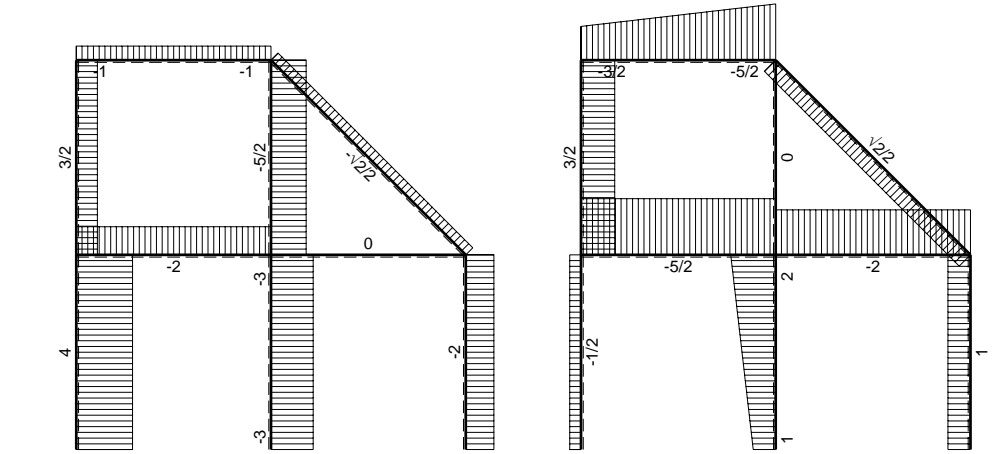
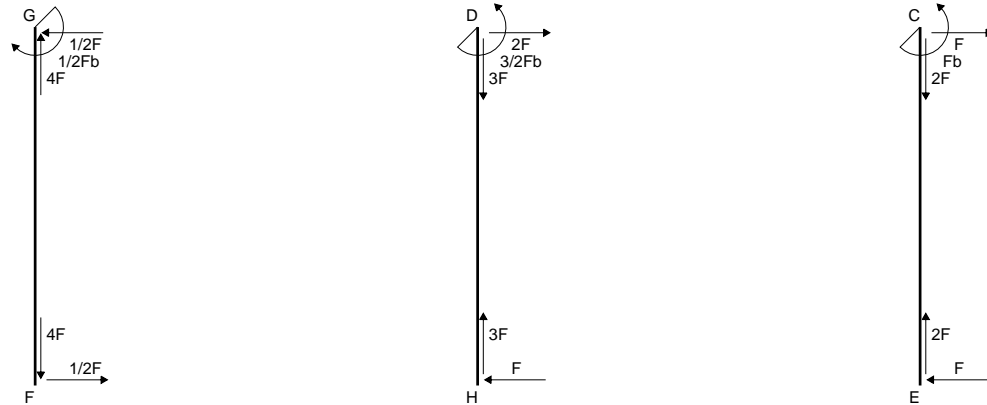
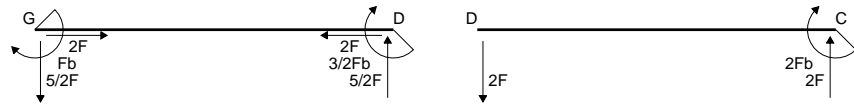
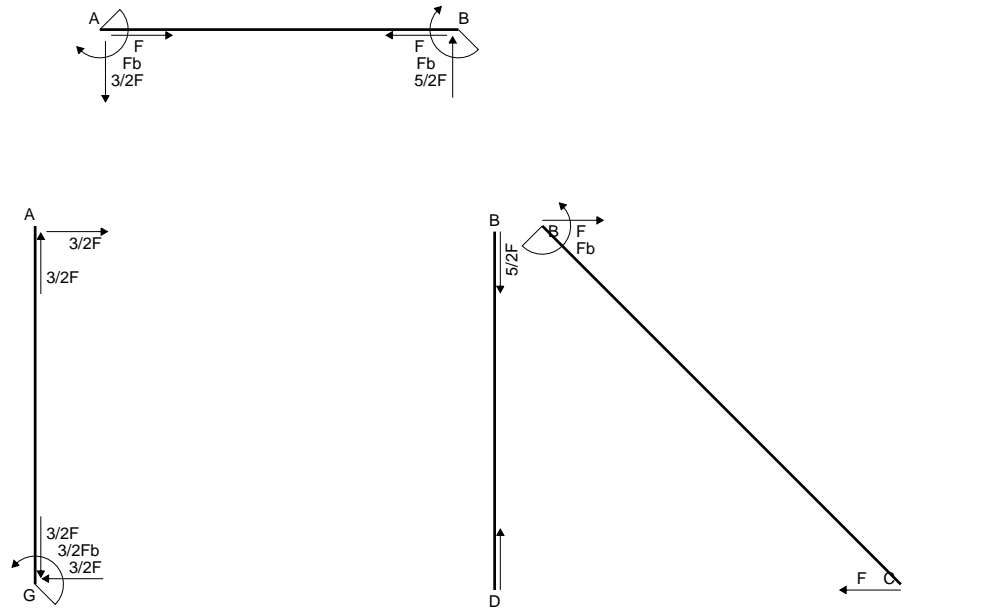

← ⊕ → F

↑ ⊕ ↓ F

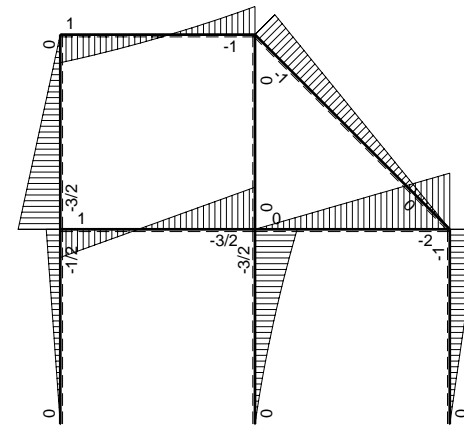

⊕ ⊖ Fb

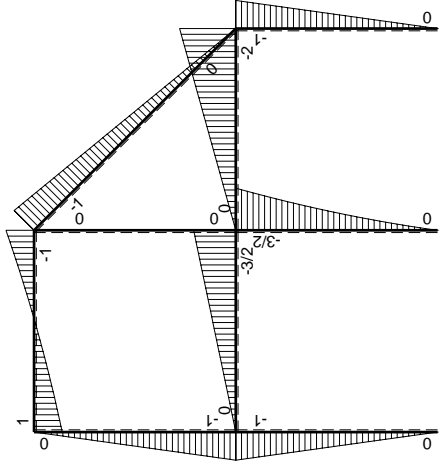
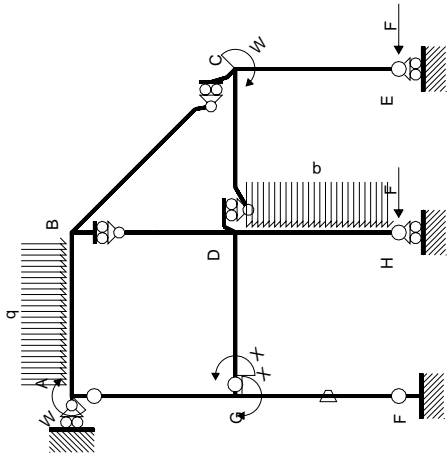

Schema di calcolo iperstatico

M_0 flessione da carichi assegnati

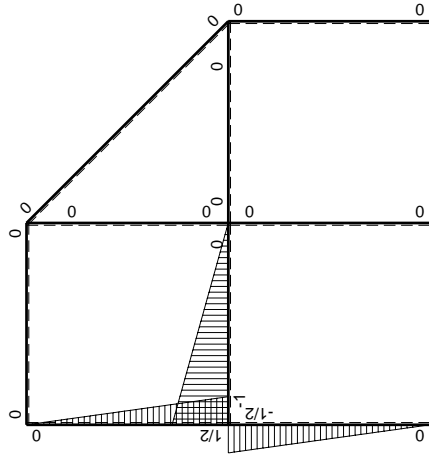

M_X flessione da iperstatica $X=1$

Quadro contributi PLV per iperstatica $X=W_{GD}$

→	$M_x(x)$	$M_o(x)$	θ	$M_x M_o$	$M_x \theta$	$M_x M_x$	$\int M_x(M_o/EJ+\theta)dx$	$\int X M_x M_x/EJ dx$
AB b	0	$Fb-3/2Fx-1/2qx^2$	0	0	0	0	0+0	0
BA b	0	$Fb-5/2Fx+1/2qx^2$	0	0	0	0	0	0
BC $\sqrt{2}b$	0	$-Fb+\sqrt{2}/2Fx$	0	0	0	0	0	0
BD b	0	0	0	0	0	0	0+0	0
DB b	0	0	0	0	0	0	0	0
DC b	0	$-2Fx$	0	0	0	0	0+0	0
CD b	0	$2Fb-2Fx$	0	0	0	0	0	0
CE b	0	$-Fb+Fx$	0	0	0	0	0+0	0
EC b	0	Fx	0	0	0	0	0	0
FG b	$-1/2x/b$	$-Fx$	$-Fb/EJ$	$1/2Fx^2/b$	$1/2Fx/EJ$	$1/4x^2/b^2$	$(1/6+1/4)Fb^2/EJ$	$1/12Xb/EJ$
GF b	$1/2-1/2x/b$	$Fb-Fx$	Fb/EJ	$1/2Fb-Fx+1/2Fx^2/b$	$1/2Fb/EJ-1/2Fx/EJ$	$1/4-1/2x/b+1/4x^2/b^2$		
GD b	$-1+x/b$	$-3/2Fx$	0	$3/2Fx-3/2Fx^2/b$	0	$1-2x/b+x^2/b^2$	$(1/4+0)Fb^2/EJ$	$1/3Xb/EJ$
DG b	x/b	$3/2Fb-3/2Fx$	0	$3/2Fx-3/2Fx^2/b$	0	x^2/b^2		
DH b	0	$-3/2Fb+2Fx-1/2qx^2$	0	0	0	0	0+0	0
HD b	0	$Fx+1/2qx^2$	0	0	0	0	0	0
GA b	$1/2-1/2x/b$	$-Fb+Fx$	0	$-1/2Fb+Fx-1/2Fx^2/b$	0	$1/4-1/2x/b+1/4x^2/b^2$	$(-1/6+0)Fb^2/EJ$	$1/12Xb/EJ$
AG b	$-1/2x/b$	Fx	0	$-1/2Fx^2/b$	0	$1/4x^2/b^2$		
	totali						$1/2Fb^2/EJ$	$1/2Xb/EJ$
	iperstatica $X=W_{GD}$						$-Fb$	

Sviluppi di calcolo iperstatica

$$L_{FG}^{xx} = \int_0^b (1/4 x^2/b^2) 1/EJ dx = [1/12 x^3/b^2]_0^b 1/EJ$$

$$= (1/12 b) 1/EJ = 1/12 b/EJ$$

$$L_{GF}^{xx} = \int_0^b (1/4 - 1/2 x/b + 1/4 x^2/b^2) 1/EJ dx = [1/4 x - 1/4 x^2/b + 1/12 x^3/b^2]_0^b 1/EJ$$

$$= (1/4 b - 1/4 b + 1/12 b) 1/EJ = 1/12 b/EJ$$

$$L_{GD}^{xx} = \int_0^b (1 - 2 x/b + x^2/b^2) 1/EJ dx = [x - x^2/b + 1/3 x^3/b^2]_0^b 1/EJ$$

$$= (b - b + 1/3 b) 1/EJ = 1/3 b/EJ$$

$$L_{DG}^{xx} = \int_0^b (x^2/b^2) 1/EJ dx = [1/3 x^3/b^2]_0^b 1/EJ$$

$$= (1/3 b) 1/EJ = 1/3 b/EJ$$

$$L_{GA}^{xx} = \int_0^b (1/4 - 1/2 x/b + 1/4 x^2/b^2) 1/EJ dx = [1/4 x - 1/4 x^2/b + 1/12 x^3/b^2]_0^b 1/EJ$$

$$= (1/4 b - 1/4 b + 1/12 b) 1/EJ = 1/12 b/EJ$$

$$L_{AG}^{xx} = \int_0^b (1/4 x^2/b^2) 1/EJ dx = [1/12 x^3/b^2]_0^b 1/EJ$$

$$= (1/12 b) 1/EJ = 1/12 b/EJ$$

$$L_{FG}^{xo} = \int_0^b (1/2 x^2/b^2) Fb 1/EJ dx + \int_0^b (1/2 x/b) \theta dx = [1/6 x^3/b^2]_0^b Fb 1/EJ + [1/4 x^2/b]_0^b \theta$$

$$= (1/6 b) Fb 1/EJ + (1/4 b) \theta = 5/12 Fb^2/EJ$$

$$L_{GF}^{xo} = \int_0^b (1/2 - x/b + 1/2 x^2/b^2) Fb 1/EJ dx + \int_0^b (-1/2 + 1/2 x/b) \theta dx$$

$$= [1/2 x - 1/2 x^2/b + 1/6 x^3/b^2]_0^b Fb 1/EJ + [-1/2 x + 1/4 x^2/b]_0^b \theta$$

$$= (1/2 b - 1/2 b + 1/6 b) Fb 1/EJ + (-1/2 b + 1/4 b) \theta = 5/12 Fb^2/EJ$$

$$L_{GD}^{xo} = \int_0^b (3/2 x/b - 3/2 x^2/b^2) Fb 1/EJ dx = [3/4 x^2/b - 1/2 x^3/b^2]_0^b Fb 1/EJ$$

$$= (3/4 b - 1/2 b) Fb 1/EJ = 1/4 Fb^2/EJ$$

$$L_{DG}^{xo} = \int_0^b (3/2 x/b - 3/2 x^2/b^2) Fb 1/EJ dx = [3/4 x^2/b - 1/2 x^3/b^2]_0^b Fb 1/EJ$$

$$= (3/4 b - 1/2 b) Fb 1/EJ = 1/4 Fb^2/EJ$$

$$L_{GA}^{xo} = \int_0^b (-1/2 + x/b - 1/2 x^2/b^2) Fb 1/EJ dx = [-1/2 x + 1/2 x^2/b - 1/6 x^3/b^2]_0^b Fb 1/EJ$$

$$= (-1/2 b + 1/2 b - 1/6 b) Fb 1/EJ = -1/6 Fb^2/EJ$$

$$L_{AG}^{xo} = \int_0^b (-1/2 x^2/b^2) Fb 1/EJ dx = [-1/6 x^3/b^2]_0^b Fb 1/EJ$$

$$= (-1/6 b) Fb 1/EJ = -1/6 Fb^2/EJ$$

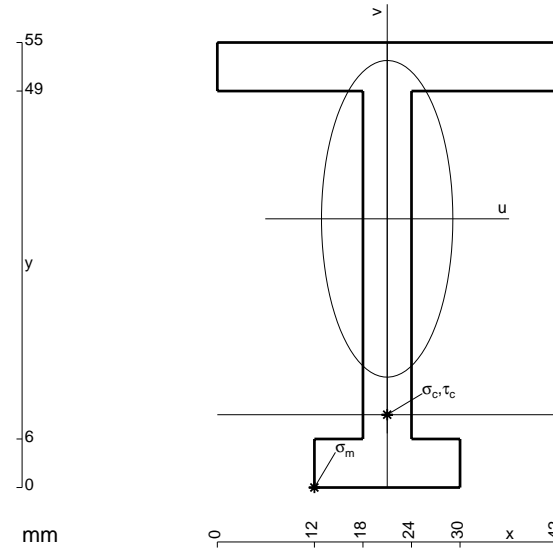

- A = 618. mm²
- J_u = 236783. mm⁴
- J_v = 40734. mm⁴
- y_g = 33.21 mm
- T_y = -1740. N
- M_x = -1705200. Nmm
- x_m = 12. mm
- u_m = -9. mm
- v_m = -33.21 mm
- σ_m = -Mv/J_u = -239.2 N/mm²
- x_c = 21. mm
- y_c = 9. mm
- v_c = -24.21 mm
- σ_c = -Mv/J_u = -174.3 N/mm²
- τ_c = 4.563 N/mm²
- σ_o = √σ_c² + 3τ_c² = 174.5 N/mm²
- S = 3725. mm³

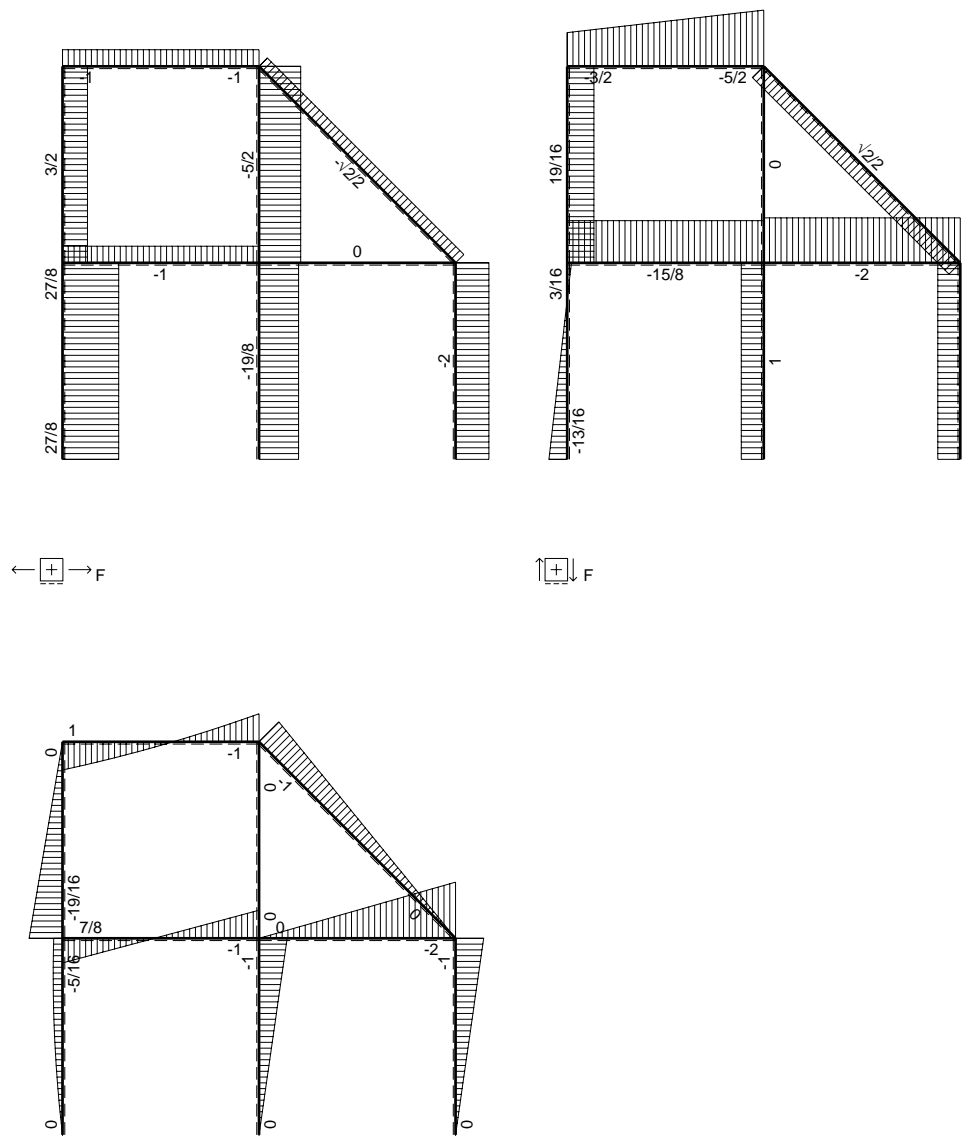
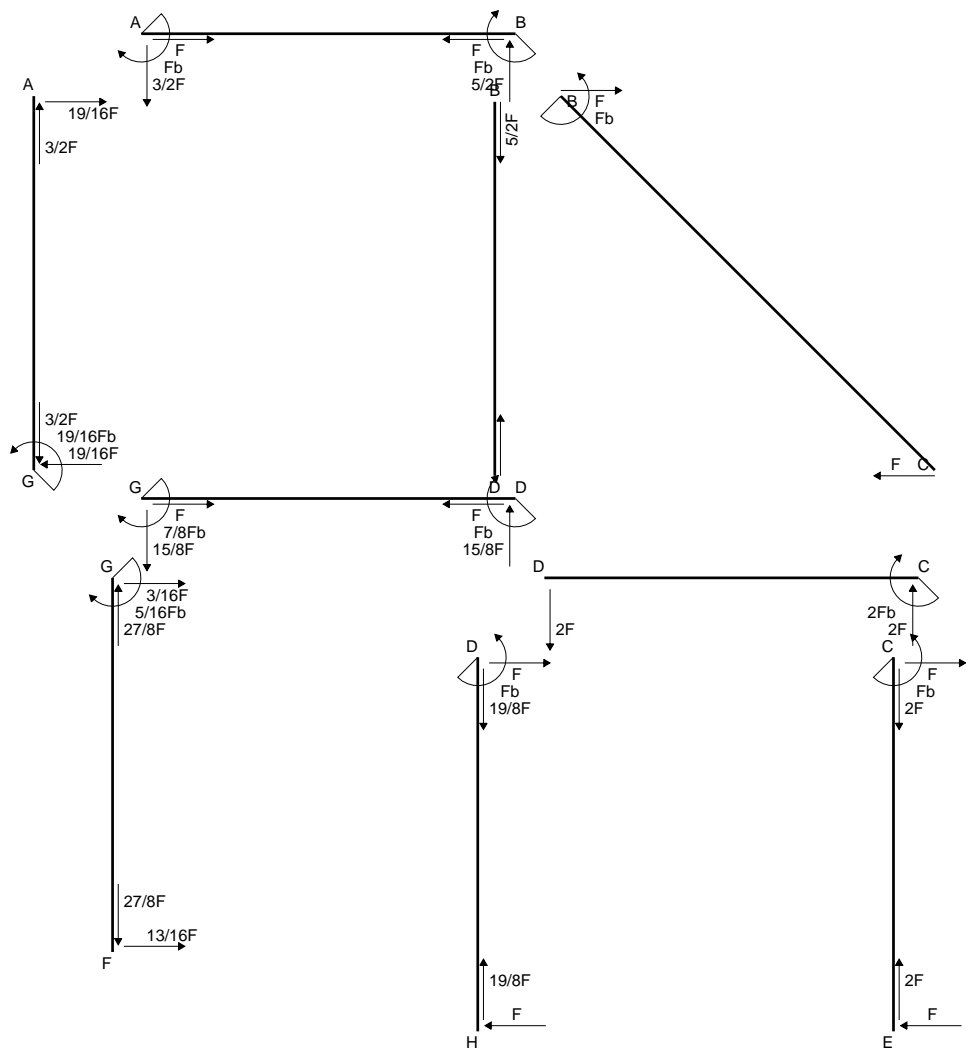

\oplus F_b

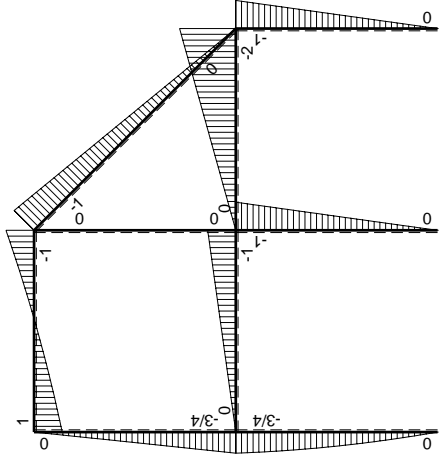
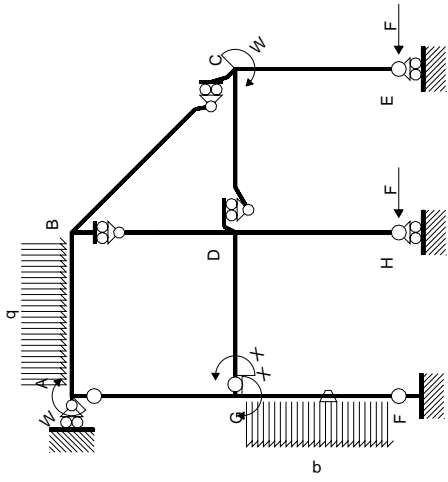

Schema di calcolo iperstatico

M_0 flessione da carichi assegnati



M_x flessione da iperstatica $X=1$

Quadro contributi PLV per iperstatica $X=W_{GD}$

→	$M_x(x)$	$M_o(x)$	θ	$M_x M_o$	$M_x \theta$	$M_x M_x$	$\int M_x(M_o/EJ+\theta)dx$	$\int x M_x M_x/EJ dx$
AB b	0	$Fb-3/2Fx-1/2qx^2$	0	0	0	0	0+0	0
BA b	0	$Fb-5/2Fx+1/2qx^2$	0	0	0	0	0	0
BC $\sqrt{2}b$	0	$-Fb+\sqrt{2}/2Fx$	0	0	0	0	0	0
BD b	0	0	0	0	0	0	0+0	0
DB b	0	0	0	0	0	0	0	0
DC b	0	$-2Fx$	0	0	0	0	0+0	0
CD b	0	$2Fb-2Fx$	0	0	0	0	0	0
CE b	0	$-Fb+Fx$	0	0	0	0	0+0	0
EC b	0	Fx	0	0	0	0	0	0
FG b	$-1/2x/b$	$-5/4Fx+1/2qx^2$	$-Fb/EJ$	$5/8Fx^2/b-1/4qx^3/b$	$1/2Fx/EJ$	$1/4x^2/b^2$	$(7/48+1/4)Fb^2/EJ$	$1/12Xb/EJ$
GF b	$1/2-1/2x/b$	$3/4Fb-1/4Fx-1/2qx^2$	Fb/EJ	$3/8Fb-1/2Fx-1/8Fx^2/b+1/4qx^3/b$	$1/2Fb/EJ-1/2Fx/EJ$	$1/4-1/2x/b+1/4x^2/b^2$		
GD b	$-1+x/b$	$-Fx$	0	$Fx-Fx^2/b$	0	$1-2x/b+x^2/b^2$	$(1/6+0)Fb^2/EJ$	$1/3Xb/EJ$
DG b	x/b	$Fb-Fx$	0	$Fx-Fx^2/b$	0	x^2/b^2		
DH b	0	$-Fb+Fx$	0	0	0	0	0+0	0
HD b	0	Fx	0	0	0	0		
GA b	$1/2-1/2x/b$	$-3/4Fb+3/4Fx$	0	$-3/8Fb+3/4Fx-3/8Fx^2/b$	0	$1/4-1/2x/b+1/4x^2/b^2$	$(-1/8+0)Fb^2/EJ$	$1/12Xb/EJ$
AG b	$-1/2x/b$	$3/4Fx$	0	$-3/8Fx^2/b$	0	$1/4x^2/b^2$		
	totali						$7/16Fb^2/EJ$	$1/2Xb/EJ$
	iperstatica $X=W_{GD}$						$-7/8Fb$	

Sviluppi di calcolo iperstatica

$$L_{FG}^{xx} = \int_0^b (1/4 x^2/b^2) 1/EJ dx = [1/12 x^3/b^2]_0^b 1/EJ$$

$$= (1/12 b) 1/EJ = 1/12 b/EJ$$

$$L_{GF}^{xx} = \int_0^b (1/4 - 1/2 x/b + 1/4 x^2/b^2) 1/EJ dx = [1/4 x - 1/4 x^2/b + 1/12 x^3/b^2]_0^b 1/EJ$$

$$= (1/4 b - 1/4 b + 1/12 b) 1/EJ = 1/12 b/EJ$$

$$L_{GD}^{xx} = \int_0^b (1 - 2 x/b + x^2/b^2) 1/EJ dx = [x - x^2/b + 1/3 x^3/b^2]_0^b 1/EJ$$

$$= (b - b + 1/3 b) 1/EJ = 1/3 b/EJ$$

$$L_{DG}^{xx} = \int_0^b (x^2/b^2) 1/EJ dx = [1/3 x^3/b^2]_0^b 1/EJ$$

$$= (1/3 b) 1/EJ = 1/3 b/EJ$$

$$L_{GA}^{xx} = \int_0^b (1/4 - 1/2 x/b + 1/4 x^2/b^2) 1/EJ dx = [1/4 x - 1/4 x^2/b + 1/12 x^3/b^2]_0^b 1/EJ$$

$$= (1/4 b - 1/4 b + 1/12 b) 1/EJ = 1/12 b/EJ$$

$$L_{AG}^{xx} = \int_0^b (1/4 x^2/b^2) 1/EJ dx = [1/12 x^3/b^2]_0^b 1/EJ$$

$$= (1/12 b) 1/EJ = 1/12 b/EJ$$

$$L_{FG}^{xo} = \int_0^b (5/8 x^2/b^2 - 1/4 x^3/b^3) Fb 1/EJ dx + \int_0^b (1/2 x/b) \theta dx$$

$$= [5/24 x^3/b^2 - 1/16 x^4/b^3]_0^b Fb 1/EJ + [1/4 x^2/b]_0^b \theta$$

$$= (5/24 b - 1/16 b) Fb 1/EJ + (1/4 b) \theta = 19/48 Fb^2/EJ$$

$$L_{GF}^{xo} = \int_0^b (3/8 - 1/2 x/b - 1/8 x^2/b^2 + 1/4 x^3/b^3) Fb 1/EJ dx + \int_0^b (-1/2 + 1/2 x/b) \theta dx$$

$$= [3/8 x - 1/4 x^2/b - 1/24 x^3/b^2 + 1/16 x^4/b^3]_0^b Fb 1/EJ + [-1/2 x + 1/4 x^2/b]_0^b \theta$$

$$= (3/8 b - 1/4 b - 1/24 b + 1/16 b) Fb 1/EJ + (-1/2 b + 1/4 b) \theta = 19/48 Fb^2/EJ$$

$$L_{GD}^{xo} = \int_0^b (x/b - x^2/b^2) Fb 1/EJ dx = [1/2 x^2/b - 1/3 x^3/b^2]_0^b Fb 1/EJ$$

$$= (1/2 b - 1/3 b) Fb 1/EJ = 1/6 Fb^2/EJ$$

$$L_{DG}^{xo} = \int_0^b (x/b - x^2/b^2) Fb 1/EJ dx = [1/2 x^2/b - 1/3 x^3/b^2]_0^b Fb 1/EJ$$

$$= (1/2 b - 1/3 b) Fb 1/EJ = 1/6 Fb^2/EJ$$

$$L_{GA}^{xo} = \int_0^b (-3/8 + 3/4 x/b - 3/8 x^2/b^2) Fb 1/EJ dx = [-3/8 x + 3/8 x^2/b - 1/8 x^3/b^2]_0^b Fb 1/EJ$$

$$= (-3/8 b + 3/8 b - 1/8 b) Fb 1/EJ = -1/8 Fb^2/EJ$$

$$L_{AG}^{xo} = \int_0^b (-3/8 x^2/b^2) Fb 1/EJ dx = [-1/8 x^3/b^2]_0^b Fb 1/EJ$$

$$= (-1/8 b) Fb 1/EJ = -1/8 Fb^2/EJ$$

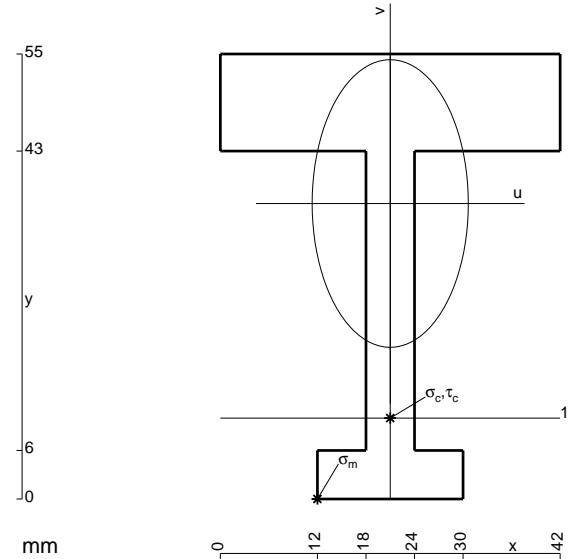

- A = 834. mm²
- J_u = 263619. mm⁴
- J_v = 77670. mm⁴
- y_g = 36.52 mm
- T_y = -2760. N
- M_x = -1435200. Nmm
- x_m = 12. mm
- u_m = -9. mm
- v_m = -36.52 mm
- σ_m = -Mv/J_u = -198.8 N/mm²
- x_c = 21. mm
- y_c = 10. mm
- v_c = -26.52 mm
- σ_c = -Mv/J_u = -144.4 N/mm²
- τ_c = 7.512 N/mm²
- σ_o = √σ²+3τ² = 145. N/mm²
- S = 4305. mm³

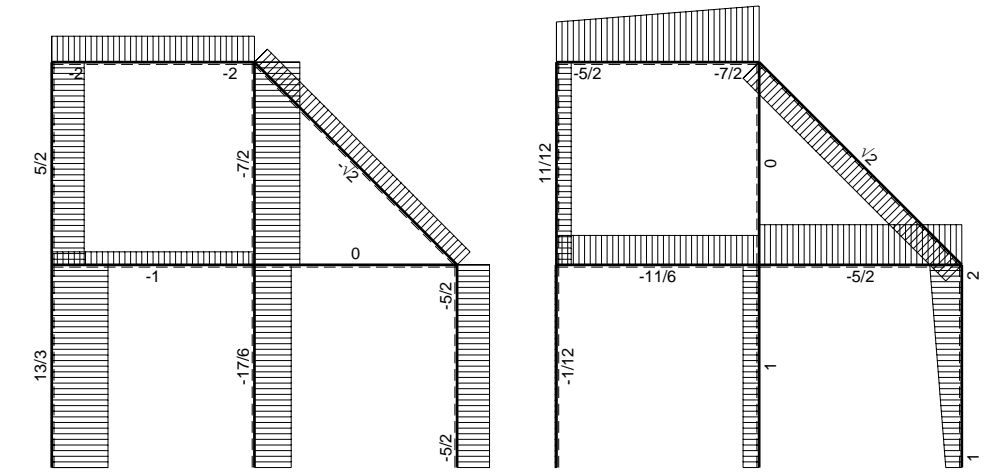
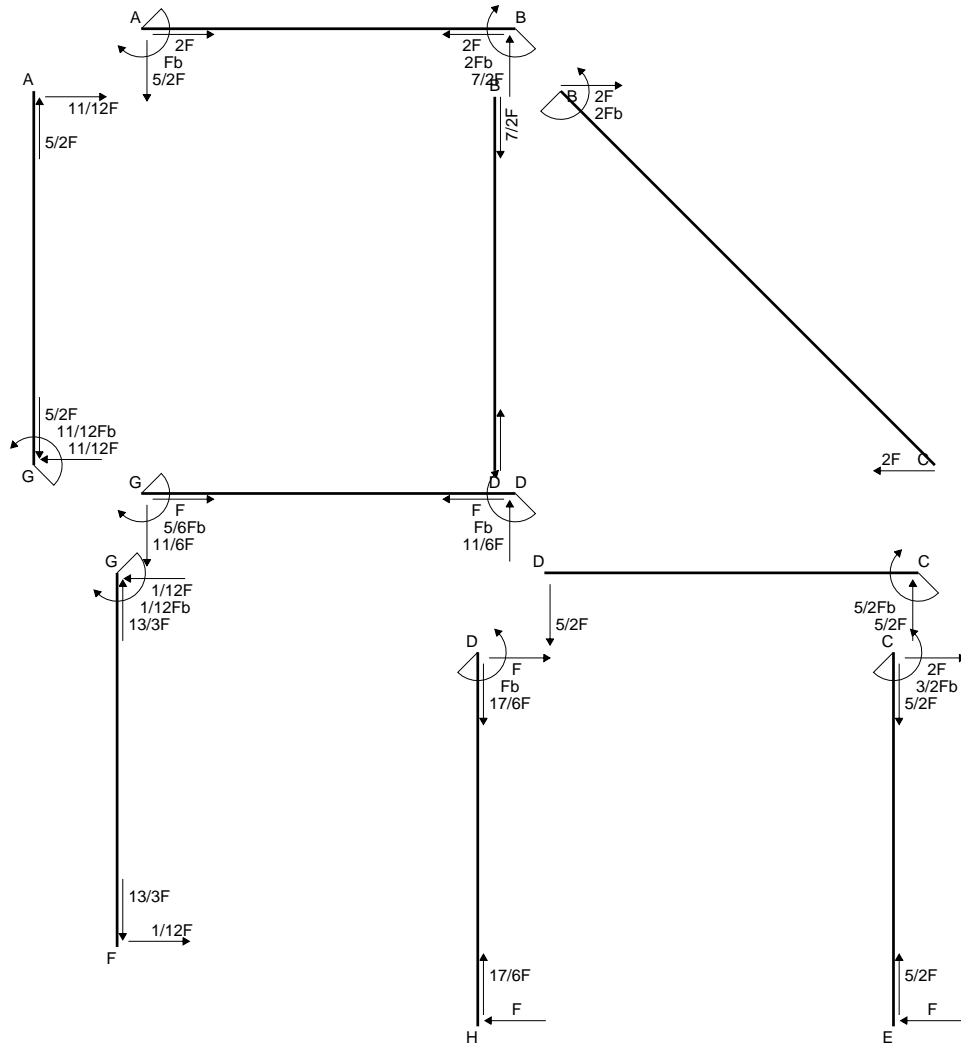

← ⊕ → F

↑ ⊕ ↓ Fb

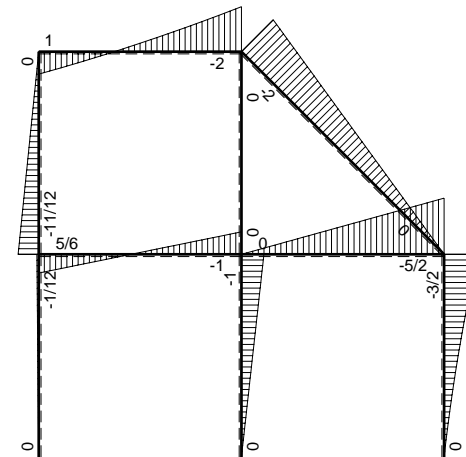

⊕ Fb

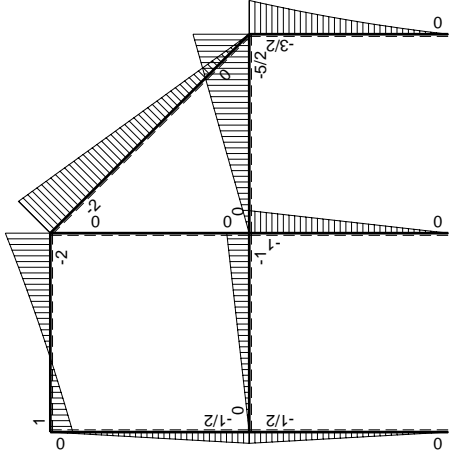
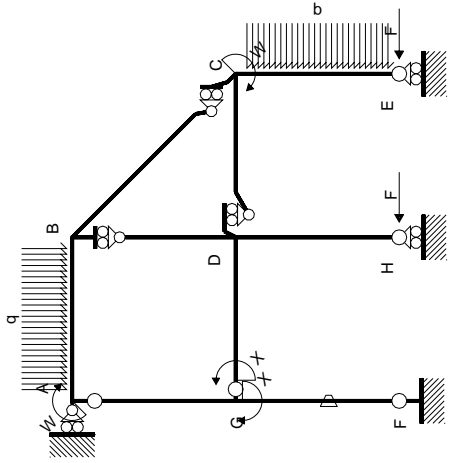

Schema di calcolo iperstatico

M_0 flessione da carichi assegnati

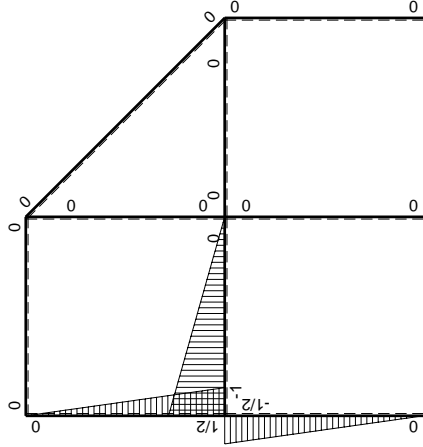

M_x flessione da iperstatica $X=1$

Quadro contributi PLV per iperstatica $X=W_{GD}$

→	$M_x(x)$	$M_o(x)$	θ	$M_x M_o$	$M_x \theta$	$M_x M_x$	$\int M_x(M_o/EJ+\theta)dx$	$\int X M_x M_x/EJ dx$
AB b	0	$Fb-5/2Fx-1/2qx^2$	0	0	0	0	0+0	0
BA b	0	$2Fb-7/2Fx+1/2qx^2$	0	0	0	0		
BC $\sqrt{2}b$	0	$-2Fb+\sqrt{2}Fx$	0	0	0	0	0	0
BD b	0	0	0	0	0	0	0+0	0
DB b	0	0	0	0	0	0		
DC b	0	$-5/2Fx$	0	0	0	0	0+0	0
CD b	0	$5/2Fb-5/2Fx$	0	0	0	0		
CE b	0	$-3/2Fb+2Fx-1/2qx^2$	0	0	0	0	0+0	0
EC b	0	$Fx+1/2qx^2$	0	0	0	0		
FG b	$-1/2x/b$	$-1/2Fx$	$-Fb/EJ$	$1/4Fx^2/b$	$1/2Fx/EJ$	$1/4x^2/b^2$	$(1/12+1/4)Fb^2/EJ$	$1/12Xb/EJ$
GF b	$1/2-1/2x/b$	$1/2Fb-1/2Fx$	Fb/EJ	$1/4Fb-1/2Fx+1/4Fx^2/b$	$1/2Fb/EJ-1/2Fx/EJ$	$1/4-1/2x/b+1/4x^2/b^2$		
GD b	$-1+x/b$	$-Fx$	0	$Fx-Fx^2/b$	0	$1-2x/b+x^2/b^2$	$(1/6+0)Fb^2/EJ$	$1/3Xb/EJ$
DG b	x/b	$Fb-Fx$	0	$Fx-Fx^2/b$	0	x^2/b^2		
DH b	0	$-Fb+Fx$	0	0	0	0	0+0	0
HD b	0	Fx	0	0	0	0		
GA b	$1/2-1/2x/b$	$-1/2Fb+1/2Fx$	0	$-1/4Fb+1/2Fx-1/4Fx^2/b$	0	$1/4-1/2x/b+1/4x^2/b^2$	$(-1/12+0)Fb^2/EJ$	$1/12Xb/EJ$
AG b	$-1/2x/b$	$1/2Fx$	0	$-1/4Fx^2/b$	0	$1/4x^2/b^2$		
	totali						$5/12Fb^2/EJ$	$1/2Xb/EJ$
	iperstatica $X=W_{GD}$						$-5/6Fb$	

Sviluppi di calcolo iperstatica

$$L_{FG}^{xx} = \int_0^b (1/4 x^2/b^2) 1/EJ dx = [1/12 x^3/b^2]_0^b 1/EJ$$

$$= (1/12 b) 1/EJ = 1/12 b/EJ$$

$$L_{GF}^{xx} = \int_0^b (1/4 - 1/2 x/b + 1/4 x^2/b^2) 1/EJ dx = [1/4 x - 1/4 x^2/b + 1/12 x^3/b^2]_0^b 1/EJ$$

$$= (1/4 b - 1/4 b + 1/12 b) 1/EJ = 1/12 b/EJ$$

$$L_{GD}^{xx} = \int_0^b (1 - 2 x/b + x^2/b^2) 1/EJ dx = [x - x^2/b + 1/3 x^3/b^2]_0^b 1/EJ$$

$$= (b - b + 1/3 b) 1/EJ = 1/3 b/EJ$$

$$L_{DG}^{xx} = \int_0^b (x^2/b^2) 1/EJ dx = [1/3 x^3/b^2]_0^b 1/EJ$$

$$= (1/3 b) 1/EJ = 1/3 b/EJ$$

$$L_{GA}^{xx} = \int_0^b (1/4 - 1/2 x/b + 1/4 x^2/b^2) 1/EJ dx = [1/4 x - 1/4 x^2/b + 1/12 x^3/b^2]_0^b 1/EJ$$

$$= (1/4 b - 1/4 b + 1/12 b) 1/EJ = 1/12 b/EJ$$

$$L_{AG}^{xx} = \int_0^b (1/4 x^2/b^2) 1/EJ dx = [1/12 x^3/b^2]_0^b 1/EJ$$

$$= (1/12 b) 1/EJ = 1/12 b/EJ$$

$$L_{FG}^{xo} = \int_0^b (1/4 x^2/b^2) Fb 1/EJ dx + \int_0^b (1/2 x/b) \theta dx = [1/12 x^3/b^2]_0^b Fb 1/EJ + [1/4 x^2/b]_0^b \theta$$

$$= (1/12 b) Fb 1/EJ + (1/4 b) \theta = 1/3 Fb^2/EJ$$

$$L_{GF}^{xo} = \int_0^b (1/4 - 1/2 x/b + 1/4 x^2/b^2) Fb 1/EJ dx + \int_0^b (-1/2 + 1/2 x/b) \theta dx$$

$$= [1/4 x - 1/4 x^2/b + 1/12 x^3/b^2]_0^b Fb 1/EJ + [-1/2 x + 1/4 x^2/b]_0^b \theta$$

$$= (1/4 b - 1/4 b + 1/12 b) Fb 1/EJ + (-1/2 b + 1/4 b) \theta = 1/3 Fb^2/EJ$$

$$L_{GD}^{xo} = \int_0^b (x/b - x^2/b^2) Fb 1/EJ dx = [1/2 x^2/b - 1/3 x^3/b^2]_0^b Fb 1/EJ$$

$$= (1/2 b - 1/3 b) Fb 1/EJ = 1/6 Fb^2/EJ$$

$$L_{DG}^{xo} = \int_0^b (x/b - x^2/b^2) Fb 1/EJ dx = [1/2 x^2/b - 1/3 x^3/b^2]_0^b Fb 1/EJ$$

$$= (1/2 b - 1/3 b) Fb 1/EJ = 1/6 Fb^2/EJ$$

$$L_{GA}^{xo} = \int_0^b (-1/4 + 1/2 x/b - 1/4 x^2/b^2) Fb 1/EJ dx = [-1/4 x + 1/4 x^2/b - 1/12 x^3/b^2]_0^b Fb 1/EJ$$

$$= (-1/4 b + 1/4 b - 1/12 b) Fb 1/EJ = -1/12 Fb^2/EJ$$

$$L_{AG}^{xo} = \int_0^b (-1/4 x^2/b^2) Fb 1/EJ dx = [-1/12 x^3/b^2]_0^b Fb 1/EJ$$

$$= (-1/12 b) Fb 1/EJ = -1/12 Fb^2/EJ$$

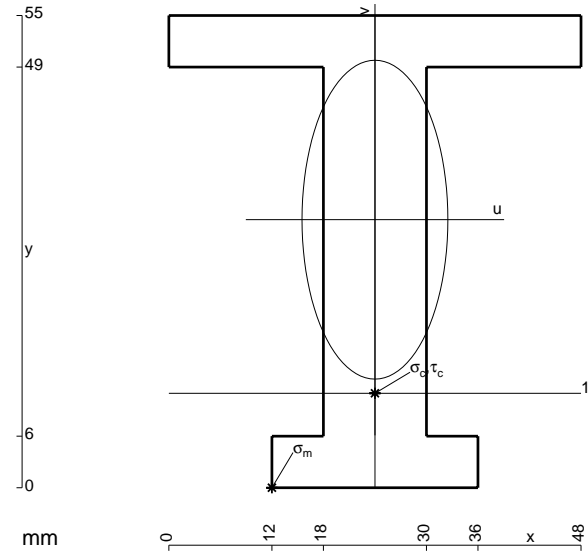

- A = 948. mm²
- J_u = 326981. mm⁴
- J_v = 68400. mm⁴
- y_g = 31.22 mm
- N = -3780. N
- T_y = -6615. N
- M_x = -2154600. Nmm
- x_m = 12. mm
- u_m = -12. mm
- v_m = -31.22 mm
- σ_m = N/A-Mv/J_u = -209.7 N/mm²
- x_c = 24. mm
- y_c = 11. mm
- v_c = -20.22 mm
- σ_c = N/A-Mv/J_u = -137.2 N/mm²
- τ_c = 9.15 N/mm²
- σ_q = √(σ²+3τ²) = 138.1 N/mm²
- S = 5427. mm³

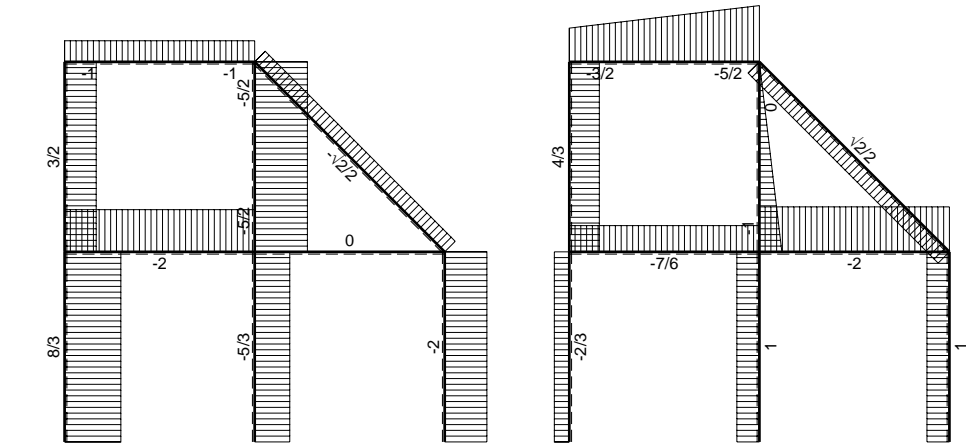
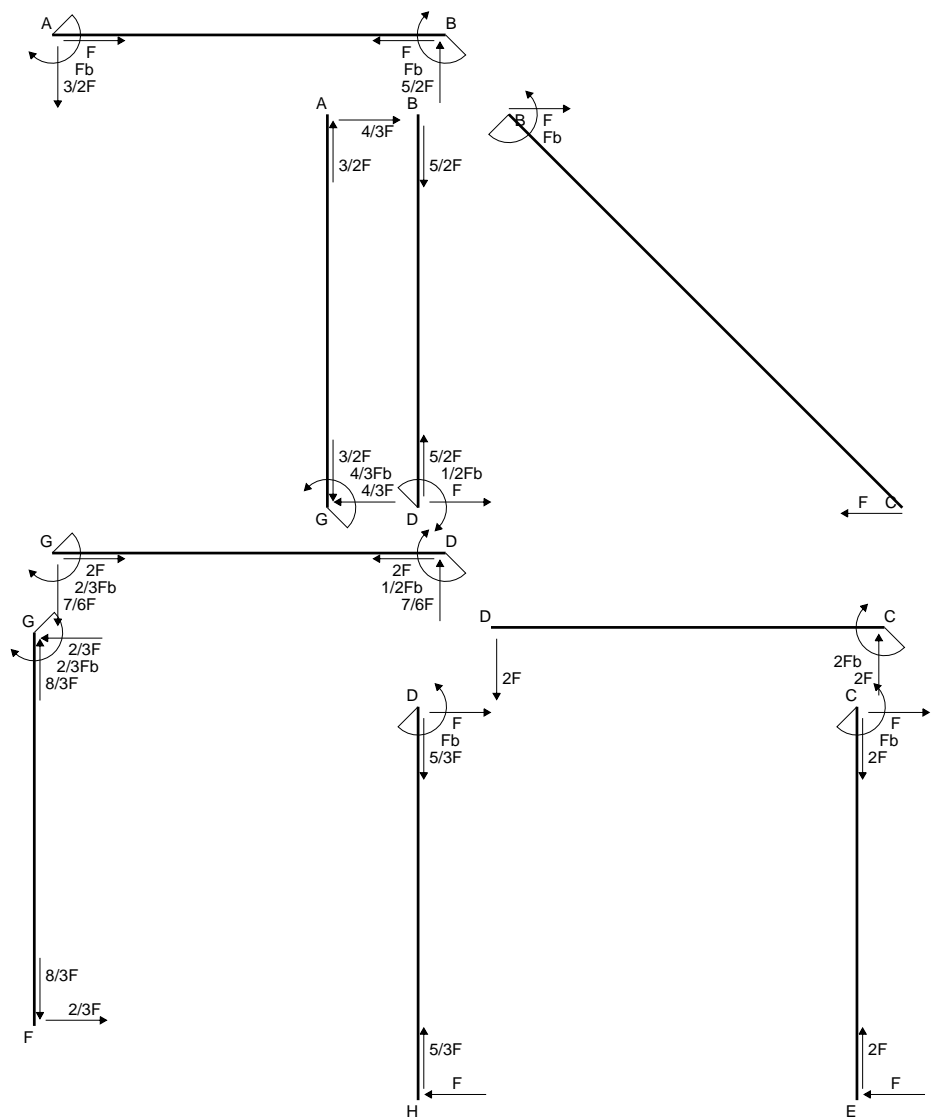

← ⊕ → F

↑ ⊕ ↓ F

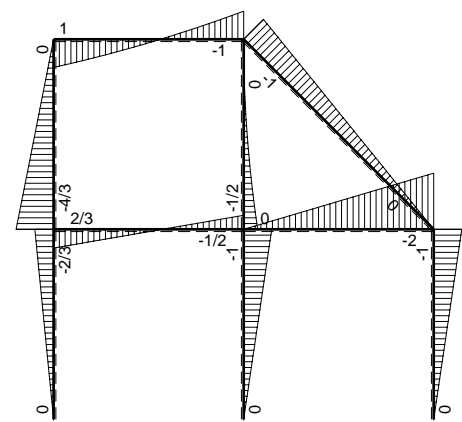

⊕ ⊖ F_b

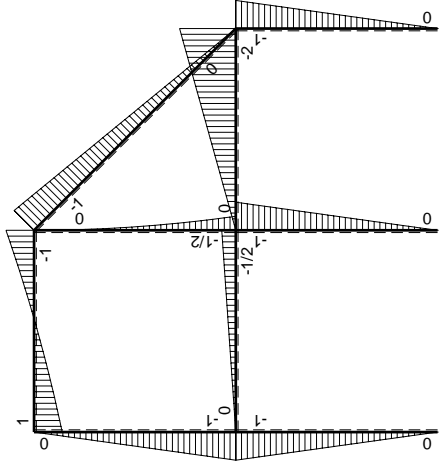
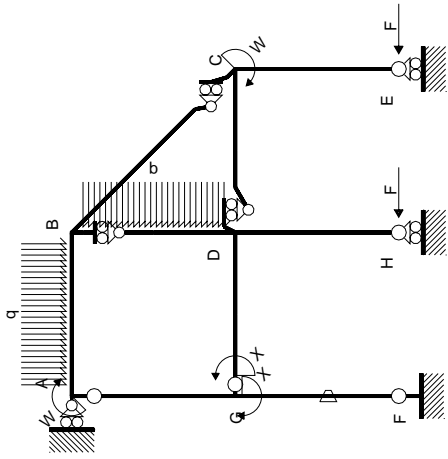

Schema di calcolo iperstatico

M_0 flessione da carichi assegnati

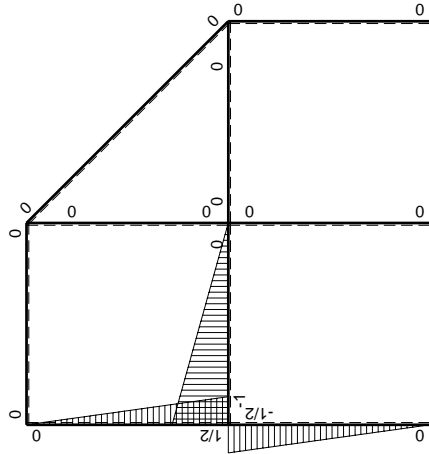

M_x flessione da iperstatica X=1

Quadro contributi PLV per iperstatica $X=W_{GD}$

→	$M_x(x)$	$M_o(x)$	θ	$M_x M_o$	$M_x \theta$	$M_x M_x$	$\int M_x(M_o/EJ+\theta)dx$	$\int X M_x M_x/EJdx$
AB b	0	$Fb-3/2Fx-1/2qx^2$	0	0	0	0	0+0	0
BA b	0	$Fb-5/2Fx+1/2qx^2$	0	0	0	0	0	0
BC $\sqrt{2}b$	0	$-Fb+\sqrt{2}/2Fx$	0	0	0	0	0	0
BD b	0	$-1/2qx^2$	0	0	0	0	0+0	0
DB b	0	$1/2Fb-Fx+1/2qx^2$	0	0	0	0	0	0
DC b	0	$-2Fx$	0	0	0	0	0+0	0
CD b	0	$2Fb-2Fx$	0	0	0	0	0	0
CE b	0	$-Fb+Fx$	0	0	0	0	0+0	0
EC b	0	Fx	0	0	0	0	0	0
FG b	$-1/2x/b$	$-Fx$	$-Fb/EJ$	$1/2Fx^2/b$	$1/2Fx/EJ$	$1/4x^2/b^2$	$(1/6+1/4)Fb^2/EJ$	$1/12Xb/EJ$
GF b	$1/2-1/2x/b$	$Fb-Fx$	Fb/EJ	$1/2Fb-Fx+1/2Fx^2/b$	$1/2Fb/EJ-1/2Fx/EJ$	$1/4-1/2x/b+1/4x^2/b^2$		
GD b	$-1+x/b$	$-1/2Fx$	0	$1/2Fx-1/2Fx^2/b$	0	$1-2x/b+x^2/b^2$	$(1/12+0)Fb^2/EJ$	$1/3Xb/EJ$
DG b	x/b	$1/2Fb-1/2Fx$	0	$1/2Fx-1/2Fx^2/b$	0	x^2/b^2		
DH b	0	$-Fb+Fx$	0	0	0	0	0+0	0
HD b	0	Fx	0	0	0	0	0	0
GA b	$1/2-1/2x/b$	$-Fb+Fx$	0	$-1/2Fb+Fx-1/2Fx^2/b$	0	$1/4-1/2x/b+1/4x^2/b^2$	$(-1/6+0)Fb^2/EJ$	$1/12Xb/EJ$
AG b	$-1/2x/b$	Fx	0	$-1/2Fx^2/b$	0	$1/4x^2/b^2$		
	totali						$1/3Fb^2/EJ$	$1/2Xb/EJ$
	iperstatica $X=W_{GD}$						$-2/3Fb$	

Sviluppi di calcolo iperstatica

$$L_{FG}^{xx} = \int_0^b (1/4 x^2/b^2) 1/EJ dx = [1/12 x^3/b^2]_0^b 1/EJ$$

$$= (1/12 b) 1/EJ = 1/12 b/EJ$$

$$L_{GF}^{xx} = \int_0^b (1/4 - 1/2 x/b + 1/4 x^2/b^2) 1/EJ dx = [1/4 x - 1/4 x^2/b + 1/12 x^3/b^2]_0^b 1/EJ$$

$$= (1/4 b - 1/4 b + 1/12 b) 1/EJ = 1/12 b/EJ$$

$$L_{GD}^{xx} = \int_0^b (1 - 2 x/b + x^2/b^2) 1/EJ dx = [x - x^2/b + 1/3 x^3/b^2]_0^b 1/EJ$$

$$= (b - b + 1/3 b) 1/EJ = 1/3 b/EJ$$

$$L_{DG}^{xx} = \int_0^b (x^2/b^2) 1/EJ dx = [1/3 x^3/b^2]_0^b 1/EJ$$

$$= (1/3 b) 1/EJ = 1/3 b/EJ$$

$$L_{GA}^{xx} = \int_0^b (1/4 - 1/2 x/b + 1/4 x^2/b^2) 1/EJ dx = [1/4 x - 1/4 x^2/b + 1/12 x^3/b^2]_0^b 1/EJ$$

$$= (1/4 b - 1/4 b + 1/12 b) 1/EJ = 1/12 b/EJ$$

$$L_{AG}^{xx} = \int_0^b (1/4 x^2/b^2) 1/EJ dx = [1/12 x^3/b^2]_0^b 1/EJ$$

$$= (1/12 b) 1/EJ = 1/12 b/EJ$$

$$L_{FG}^{xo} = \int_0^b (1/2 x^2/b^2) Fb 1/EJ dx + \int_0^b (1/2 x/b) \theta dx = [1/6 x^3/b^2]_0^b Fb 1/EJ + [1/4 x^2/b]_0^b \theta$$

$$= (1/6 b) Fb 1/EJ + (1/4 b) \theta = 5/12 Fb^2/EJ$$

$$L_{GF}^{xo} = \int_0^b (1/2 - x/b + 1/2 x^2/b^2) Fb 1/EJ dx + \int_0^b (-1/2 + 1/2 x/b) \theta dx$$

$$= [1/2 x - 1/2 x^2/b + 1/6 x^3/b^2]_0^b Fb 1/EJ + [-1/2 x + 1/4 x^2/b]_0^b \theta$$

$$= (1/2 b - 1/2 b + 1/6 b) Fb 1/EJ + (-1/2 b + 1/4 b) \theta = 5/12 Fb^2/EJ$$

$$L_{GD}^{xo} = \int_0^b (1/2 x/b - 1/2 x^2/b^2) Fb 1/EJ dx = [1/4 x^2/b - 1/6 x^3/b^2]_0^b Fb 1/EJ$$

$$= (1/4 b - 1/6 b) Fb 1/EJ = 1/12 Fb^2/EJ$$

$$L_{DG}^{xo} = \int_0^b (1/2 x/b - 1/2 x^2/b^2) Fb 1/EJ dx = [1/4 x^2/b - 1/6 x^3/b^2]_0^b Fb 1/EJ$$

$$= (1/4 b - 1/6 b) Fb 1/EJ = 1/12 Fb^2/EJ$$

$$L_{GA}^{xo} = \int_0^b (-1/2 + x/b - 1/2 x^2/b^2) Fb 1/EJ dx = [-1/2 x + 1/2 x^2/b - 1/6 x^3/b^2]_0^b Fb 1/EJ$$

$$= (-1/2 b + 1/2 b - 1/6 b) Fb 1/EJ = -1/6 Fb^2/EJ$$

$$L_{AG}^{xo} = \int_0^b (-1/2 x^2/b^2) Fb 1/EJ dx = [-1/6 x^3/b^2]_0^b Fb 1/EJ$$

$$= (-1/6 b) Fb 1/EJ = -1/6 Fb^2/EJ$$

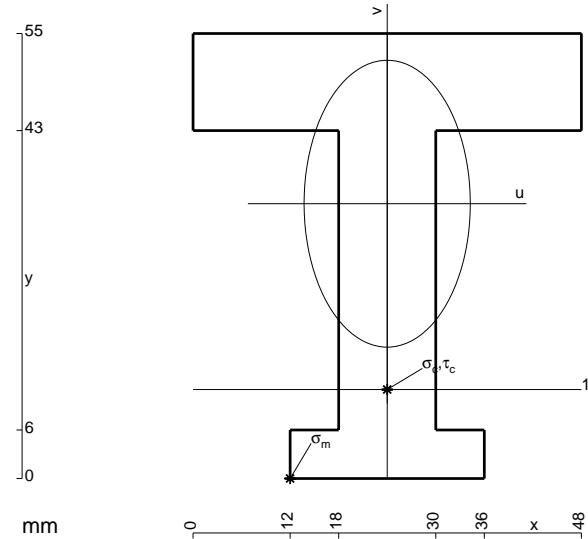

- A = 1164. mm²
- J_u = 366051. mm⁴
- J_v = 122832. mm⁴
- y_g = 33.96 mm
- T_y = -3820. N
- M_x = -2368400. Nmm
- x_m = 12. mm
- u_m = -12. mm
- v_m = -33.96 mm
- σ_m = -Mv/J_u = -219.8 N/mm²
- x_c = 24. mm
- y_c = 11. mm
- v_c = -22.96 mm
- σ_c = -Mv/J_u = -148.6 N/mm²
- τ_c = 5.206 N/mm²
- σ_o = √σ²+3τ² = 148.9 N/mm²
- S = 5987. mm³

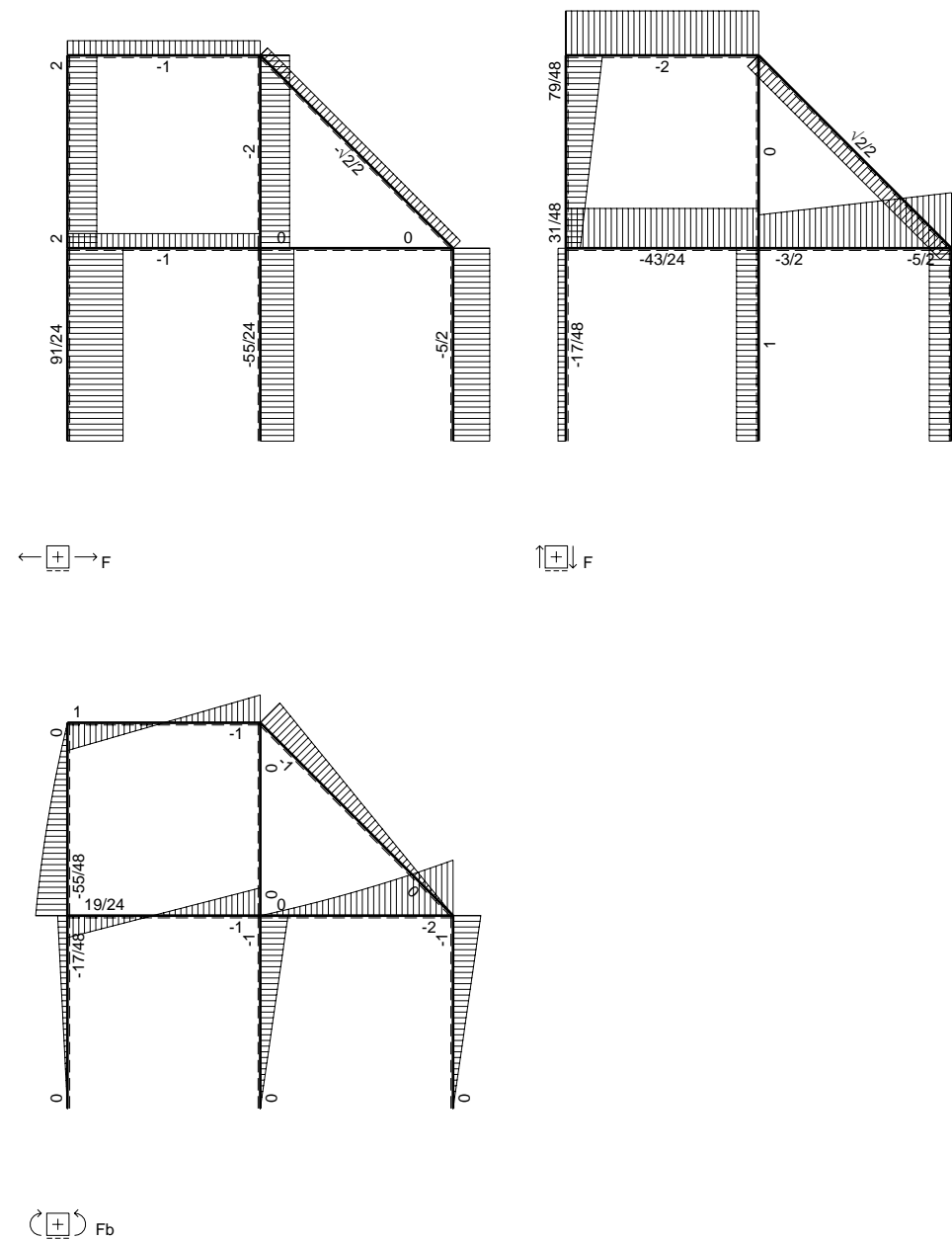
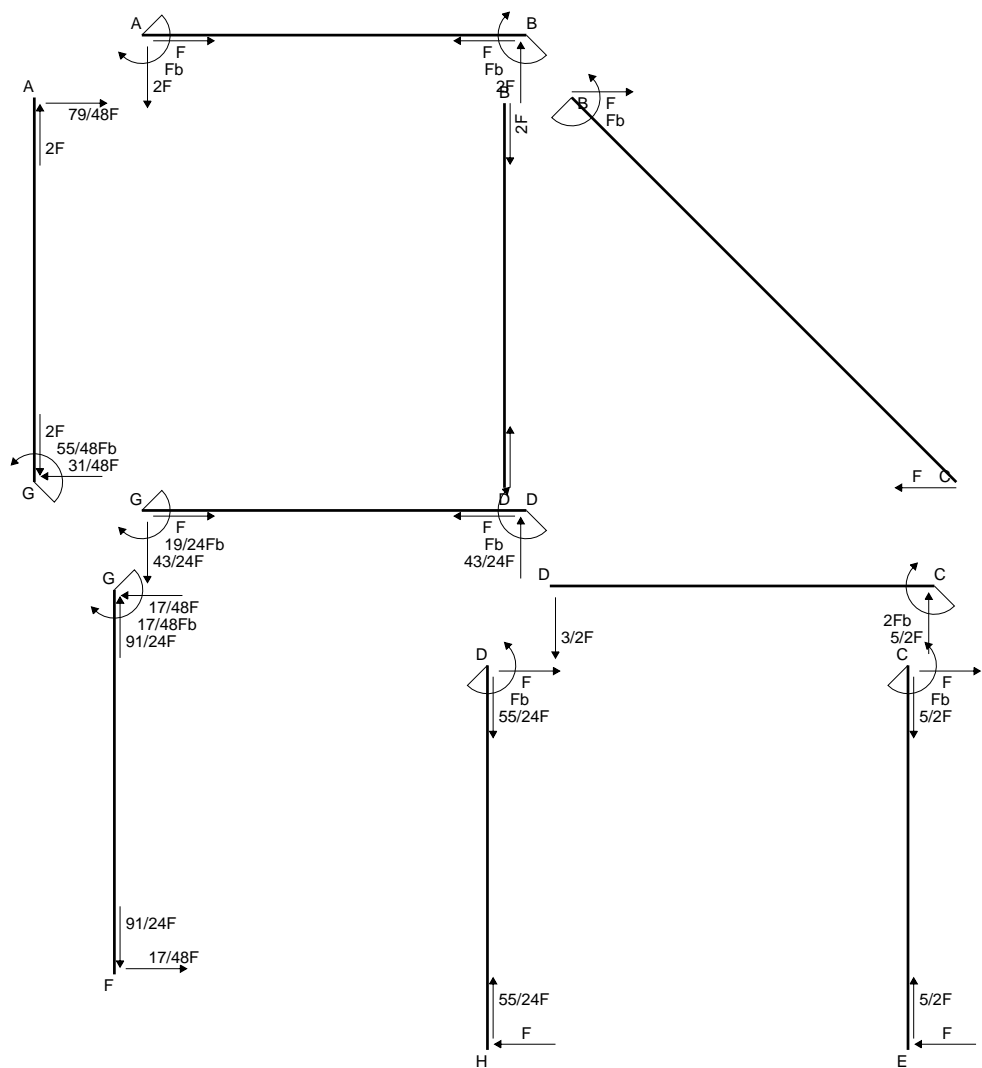

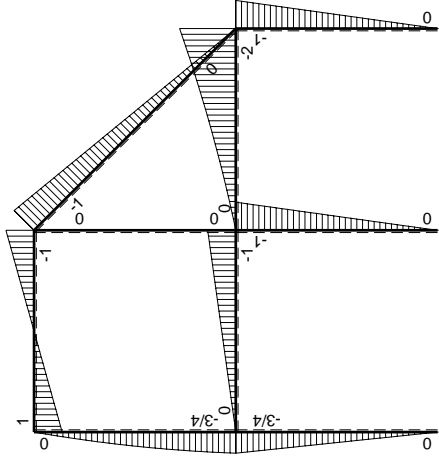
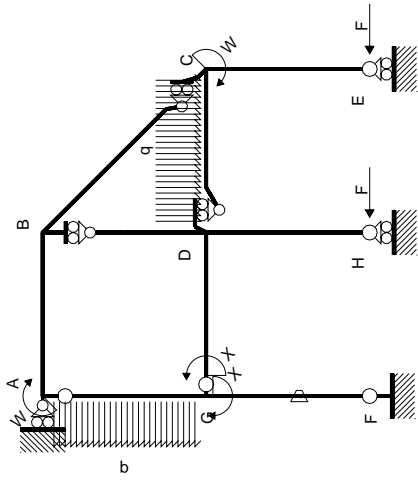

Schema di calcolo iperstatico

M_0 flessione da carichi assegnati

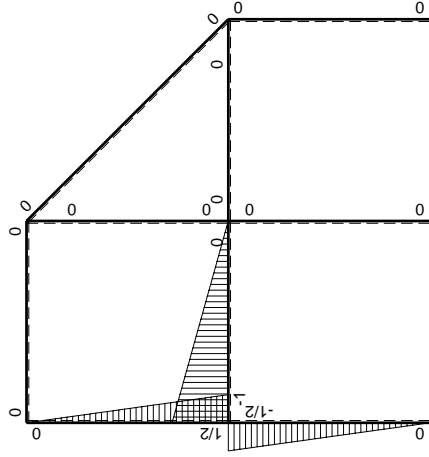

M_x flessione da iperstatica X=1

Quadro contributi PLV per iperstatica $X=W_{GD}$

→	$M_x(x)$	$M_o(x)$	θ	$M_x M_o$	$M_x \theta$	$M_x M_x$	$\int M_x(M_o/EJ+\theta)dx$	$\int X M_x M_x/EJ dx$
AB b	0	Fb-2Fx	0	0	0	0	0+0	0
BA b	0	Fb-2Fx	0	0	0	0	0	0
BC $\sqrt{2}b$	0	-Fb+ $\sqrt{2}/2Fx$	0	0	0	0	0	0
BD b	0	0	0	0	0	0	0+0	0
DB b	0	0	0	0	0	0	0	0
DC b	0	-3/2Fx-1/2qx ²	0	0	0	0	0+0	0
CD b	0	2Fb-5/2Fx+1/2qx ²	0	0	0	0	0	0
CE b	0	-Fb+Fx	0	0	0	0	0+0	0
EC b	0	Fx	0	0	0	0	0	0
FG b	-1/2x/b	-3/4Fx	-Fb/EJ	3/8Fx ² /b	1/2Fx/EJ	1/4x ² /b ²	(1/8+1/4)Fb ² /EJ	1/12Xb/EJ
GF b	1/2-1/2x/b	3/4Fb-3/4Fx	Fb/EJ	3/8Fb-3/4Fx+3/8Fx ² /b	1/2Fb/EJ-1/2Fx/EJ	1/4-1/2x/b+1/4x ² /b ²		
GD b	-1+x/b	-Fx	0	Fx-Fx ² /b	0	1-2x/b+x ² /b ²	(1/6+0)Fb ² /EJ	1/3Xb/EJ
DG b	x/b	Fb-Fx	0	Fx-Fx ² /b	0	x ² /b ²		
DH b	0	-Fb+Fx	0	0	0	0	0+0	0
HD b	0	Fx	0	0	0	0	0	0
GA b	1/2-1/2x/b	-3/4Fb+1/4Fx+1/2qx ²	0	-3/8Fb+1/2Fx+1/8Fx ² /b-1/4qx ³ /b	0	1/4-1/2x/b+1/4x ² /b ²	(-7/48+0)Fb ² /EJ	1/12Xb/EJ
AG b	-1/2x/b	5/4Fx-1/2qx ²	0	-5/8Fx ² /b+1/4qx ³ /b	0	1/4x ² /b ²		
	totali						19/48Fb ² /EJ	1/2Xb/EJ
	iperstatica $X=W_{GD}$						-19/24Fb	

Sviluppi di calcolo iperstatica

$$L_{FG}^{xx} = \int_0^b (1/4 x^2/b^2) 1/EJ dx = [1/12 x^3/b^2]_0^b 1/EJ$$

$$= (1/12 b) 1/EJ = 1/12 b/EJ$$

$$L_{GF}^{xx} = \int_0^b (1/4 - 1/2 x/b + 1/4 x^2/b^2) 1/EJ dx = [1/4 x - 1/4 x^2/b + 1/12 x^3/b^2]_0^b 1/EJ$$

$$= (1/4 b - 1/4 b + 1/12 b) 1/EJ = 1/12 b/EJ$$

$$L_{GD}^{xx} = \int_0^b (1 - 2 x/b + x^2/b^2) 1/EJ dx = [x - x^2/b + 1/3 x^3/b^2]_0^b 1/EJ$$

$$= (b - b + 1/3 b) 1/EJ = 1/3 b/EJ$$

$$L_{DG}^{xx} = \int_0^b (x^2/b^2) 1/EJ dx = [1/3 x^3/b^2]_0^b 1/EJ$$

$$= (1/3 b) 1/EJ = 1/3 b/EJ$$

$$L_{GA}^{xx} = \int_0^b (1/4 - 1/2 x/b + 1/4 x^2/b^2) 1/EJ dx = [1/4 x - 1/4 x^2/b + 1/12 x^3/b^2]_0^b 1/EJ$$

$$= (1/4 b - 1/4 b + 1/12 b) 1/EJ = 1/12 b/EJ$$

$$L_{AG}^{xx} = \int_0^b (1/4 x^2/b^2) 1/EJ dx = [1/12 x^3/b^2]_0^b 1/EJ$$

$$= (1/12 b) 1/EJ = 1/12 b/EJ$$

$$L_{FG}^{xo} = \int_0^b (3/8 x^2/b^2) Fb 1/EJ dx + \int_0^b (1/2 x/b) \theta dx = [1/8 x^3/b^2]_0^b Fb 1/EJ + [1/4 x^2/b]_0^b \theta$$

$$= (1/8 b) Fb 1/EJ + (1/4 b) \theta = 3/8 Fb^2/EJ$$

$$L_{GF}^{xo} = \int_0^b (3/8 - 3/4 x/b + 3/8 x^2/b^2) Fb 1/EJ dx + \int_0^b (-1/2 + 1/2 x/b) \theta dx$$

$$= [3/8 x - 3/8 x^2/b + 1/8 x^3/b^2]_0^b Fb 1/EJ + [-1/2 x + 1/4 x^2/b]_0^b \theta$$

$$= (3/8 b - 3/8 b + 1/8 b) Fb 1/EJ + (-1/2 b + 1/4 b) \theta = 3/8 Fb^2/EJ$$

$$L_{GD}^{xo} = \int_0^b (x/b - x^2/b^2) Fb 1/EJ dx = [1/2 x^2/b - 1/3 x^3/b^2]_0^b Fb 1/EJ$$

$$= (1/2 b - 1/3 b) Fb 1/EJ = 1/6 Fb^2/EJ$$

$$L_{DG}^{xo} = \int_0^b (x/b - x^2/b^2) Fb 1/EJ dx = [1/2 x^2/b - 1/3 x^3/b^2]_0^b Fb 1/EJ$$

$$= (1/2 b - 1/3 b) Fb 1/EJ = 1/6 Fb^2/EJ$$

$$L_{GA}^{xo} = \int_0^b (-3/8 + 1/2 x/b + 1/8 x^2/b^2 - 1/4 x^3/b^3) Fb 1/EJ dx$$

$$= [-3/8 x + 1/4 x^2/b + 1/24 x^3/b^2 - 1/16 x^4/b^3]_0^b Fb 1/EJ$$

$$= (-3/8 b + 1/4 b + 1/24 b - 1/16 b) Fb 1/EJ = -7/48 Fb^2/EJ$$

$$L_{AG}^{xo} = \int_0^b (-5/8 x^2/b^2 + 1/4 x^3/b^3) Fb 1/EJ dx = [-5/24 x^3/b^2 + 1/16 x^4/b^3]_0^b Fb 1/EJ$$

$$= (-5/24 b + 1/16 b) Fb 1/EJ = -7/48 Fb^2/EJ$$

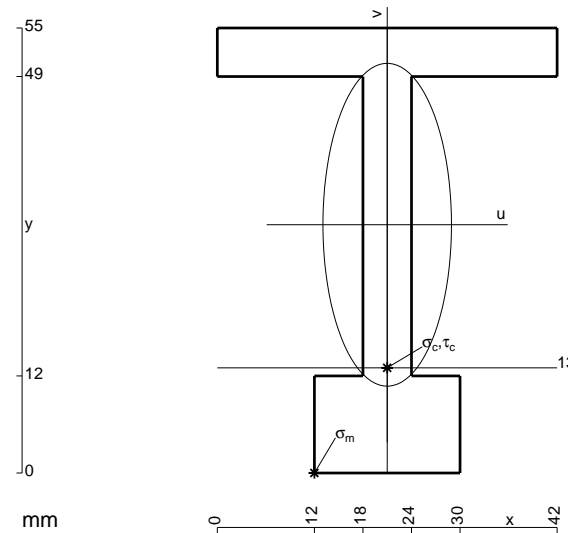

$A = 690. \text{ mm}^2$
 $J_u = 274792. \text{ mm}^4$
 $J_v = 43542. \text{ mm}^4$
 $y_g = 30.68 \text{ mm}$
 $T_y = -3825. \text{ N}$
 $M_x = -2050200. \text{ Nmm}$
 $x_m = 12. \text{ mm}$
 $u_m = -9. \text{ mm}$
 $v_m = -30.68 \text{ mm}$
 $\sigma_m = -Mv/J_u = -228.9 \text{ N/mm}^2$
 $x_c = 21. \text{ mm}$
 $y_c = 13. \text{ mm}$
 $v_c = -17.68 \text{ mm}$
 $\sigma_c = -Mv/J_u = -131.9 \text{ N/mm}^2$
 $\tau_c = 12.62 \text{ N/mm}^2$
 $\sigma_q = \sqrt{\sigma^2 + 3\tau^2} = 133.7 \text{ N/mm}^2$
 $S = 5441. \text{ mm}^3$

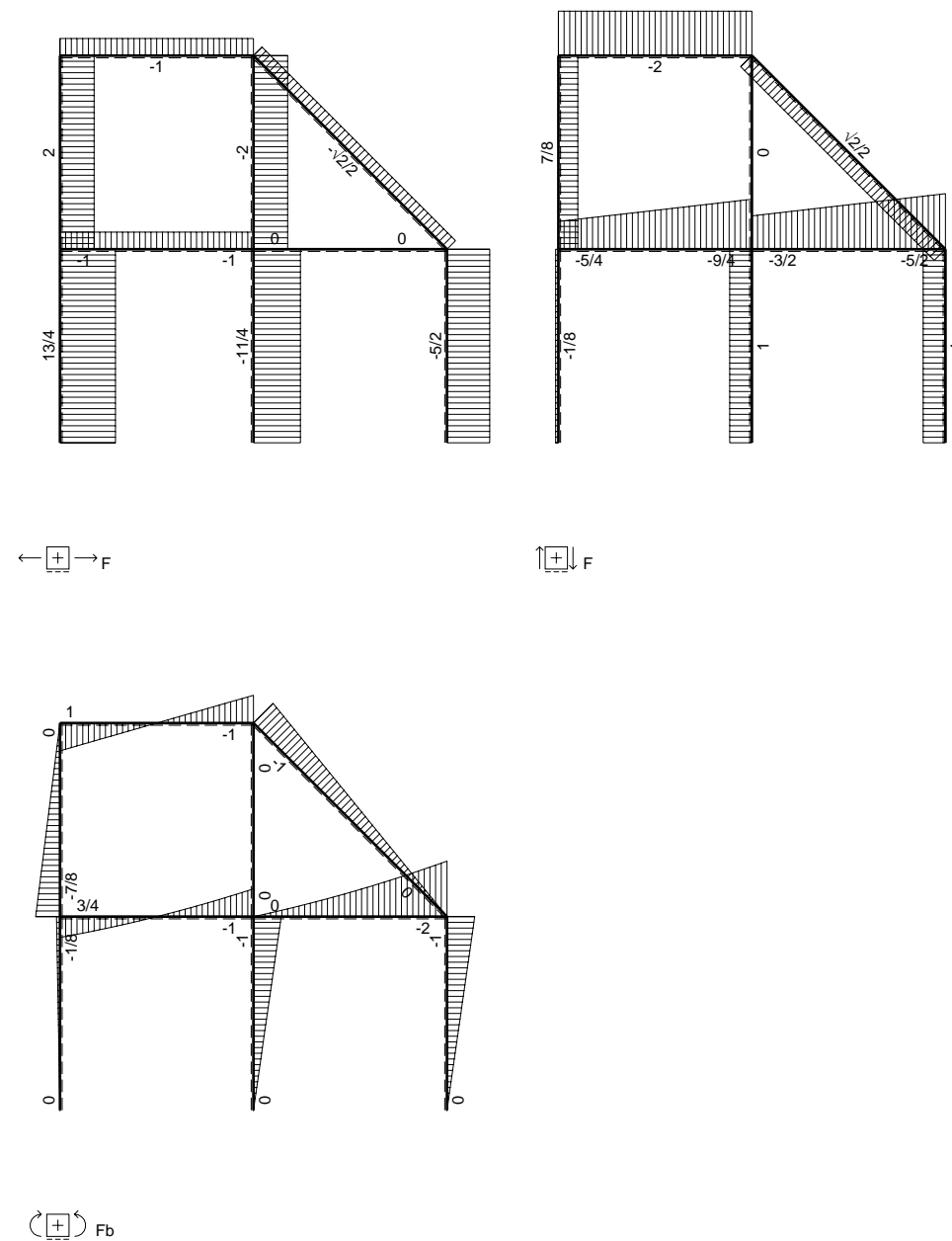
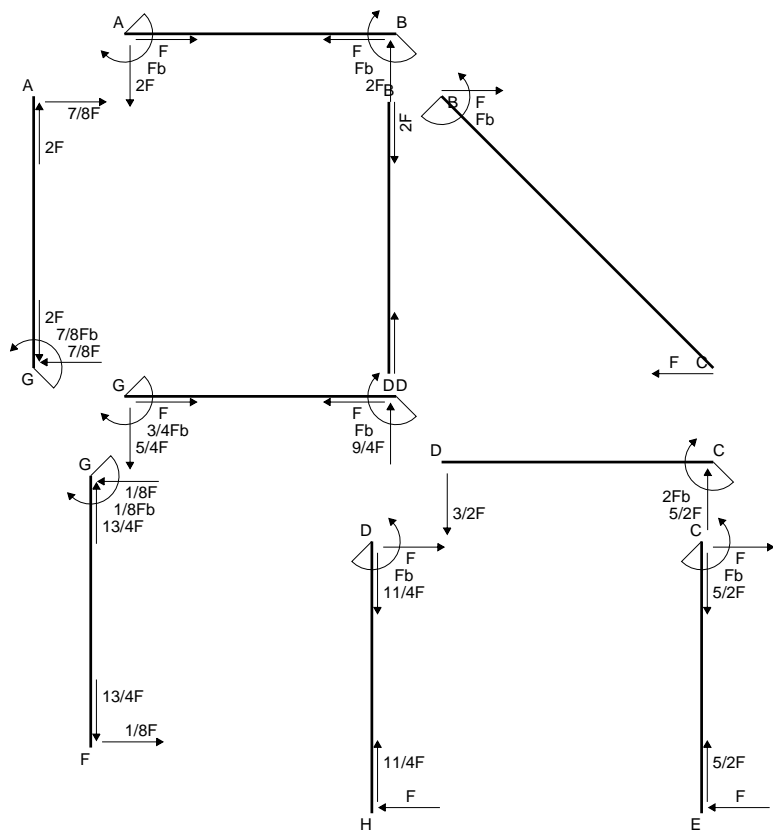

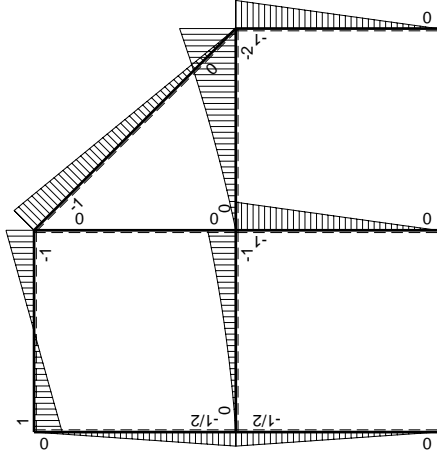
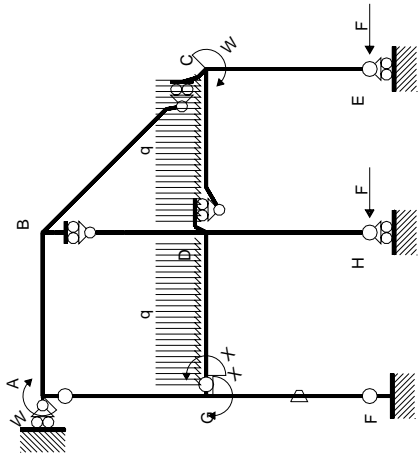

Schema di calcolo iperstatico

M_0 flessione da carichi assegnati

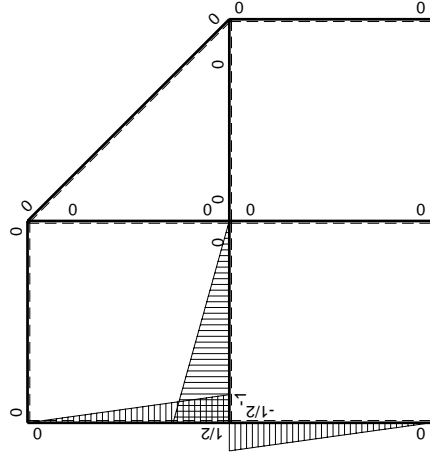

M_1 flessione da iperstatica $X=1$

Quadro contributi PLV per iperstatica $X=W_{GD}$

→	$M_x(x)$	$M_o(x)$	θ	$M_x M_o$	$M_x \theta$	$M_x M_x$	$\int M_x(M_o/EJ+\theta)dx$	$\int X M_x M_x / EJ dx$
AB b	0	$Fb-2Fx$	0	0	0	0	0+0	0
BA b	0	$Fb-2Fx$	0	0	0	0		
BC $\sqrt{2}b$	0	$-Fb+\sqrt{2}/2Fx$	0	0	0	0	0	0
BD b	0	0	0	0	0	0	0+0	0
DB b	0	0	0	0	0	0		
DC b	0	$-3/2Fx-1/2qx^2$	0	0	0	0	0+0	0
CD b	0	$2Fb-5/2Fx+1/2qx^2$	0	0	0	0		
CE b	0	$-Fb+Fx$	0	0	0	0	0+0	0
EC b	0	Fx	0	0	0	0		
FG b	$-1/2x/b$	$-1/2Fx$	$-Fb/EJ$	$1/4Fx^2/b$	$1/2Fx/EJ$	$1/4x^2/b^2$	$(1/12+1/4)Fb^2/EJ$	$1/12Xb/EJ$
GF b	$1/2-1/2x/b$	$1/2Fb-1/2Fx$	Fb/EJ	$1/4Fb-1/2Fx+1/4Fx^2/b$	$1/2Fb/EJ-1/2Fx/EJ$	$1/4-1/2x/b+1/4x^2/b^2$		
GD b	$-1+x/b$	$-1/2Fx-1/2qx^2$	0	$1/2Fx-1/2qx^3/b$	0	$1-2x/b+x^2/b^2$	$(1/8+0)Fb^2/EJ$	$1/3Xb/EJ$
DG b	x/b	$Fb-3/2Fx+1/2qx^2$	0	$Fx-3/2Fx^2/b+1/2qx^3/b$	0	x^2/b^2		
DH b	0	$-Fb+Fx$	0	0	0	0	0+0	0
HD b	0	Fx	0	0	0	0		
GA b	$1/2-1/2x/b$	$-1/2Fb+1/2Fx$	0	$-1/4Fb+1/2Fx-1/4Fx^2/b$	0	$1/4-1/2x/b+1/4x^2/b^2$	$(-1/12+0)Fb^2/EJ$	$1/12Xb/EJ$
AG b	$-1/2x/b$	$1/2Fx$	0	$-1/4Fx^2/b$	0	$1/4x^2/b^2$		
	totali						$3/8Fb^2/EJ$	$1/2Xb/EJ$
	iperstatica $X=W_{GD}$						$-3/4Fb$	

Sviluppi di calcolo iperstatica

$$L_{FG}^{xx} = \int_0^b (1/4 x^2/b^2) 1/EJ dx = [1/12 x^3/b^2]_0^b 1/EJ$$

$$= (1/12 b) 1/EJ = 1/12 b/EJ$$

$$L_{GF}^{xx} = \int_0^b (1/4 - 1/2 x/b + 1/4 x^2/b^2) 1/EJ dx = [1/4 x - 1/4 x^2/b + 1/12 x^3/b^2]_0^b 1/EJ$$

$$= (1/4 b - 1/4 b + 1/12 b) 1/EJ = 1/12 b/EJ$$

$$L_{GD}^{xx} = \int_0^b (1 - 2 x/b + x^2/b^2) 1/EJ dx = [x - x^2/b + 1/3 x^3/b^2]_0^b 1/EJ$$

$$= (b - b + 1/3 b) 1/EJ = 1/3 b/EJ$$

$$L_{DG}^{xx} = \int_0^b (x^2/b^2) 1/EJ dx = [1/3 x^3/b^2]_0^b 1/EJ$$

$$= (1/3 b) 1/EJ = 1/3 b/EJ$$

$$L_{GA}^{xx} = \int_0^b (1/4 - 1/2 x/b + 1/4 x^2/b^2) 1/EJ dx = [1/4 x - 1/4 x^2/b + 1/12 x^3/b^2]_0^b 1/EJ$$

$$= (1/4 b - 1/4 b + 1/12 b) 1/EJ = 1/12 b/EJ$$

$$L_{AG}^{xx} = \int_0^b (1/4 x^2/b^2) 1/EJ dx = [1/12 x^3/b^2]_0^b 1/EJ$$

$$= (1/12 b) 1/EJ = 1/12 b/EJ$$

$$L_{FG}^{xo} = \int_0^b (1/4 x^2/b^2) Fb 1/EJ dx + \int_0^b (1/2 x/b) \theta dx = [1/12 x^3/b^2]_0^b Fb 1/EJ + [1/4 x^2/b]_0^b \theta$$

$$= (1/12 b) Fb 1/EJ + (1/4 b) \theta = 1/3 Fb^2/EJ$$

$$L_{GF}^{xo} = \int_0^b (1/4 - 1/2 x/b + 1/4 x^2/b^2) Fb 1/EJ dx + \int_0^b (-1/2 + 1/2 x/b) \theta dx$$

$$= [1/4 x - 1/4 x^2/b + 1/12 x^3/b^2]_0^b Fb 1/EJ + [-1/2 x + 1/4 x^2/b]_0^b \theta$$

$$= (1/4 b - 1/4 b + 1/12 b) Fb 1/EJ + (-1/2 b + 1/4 b) \theta = 1/3 Fb^2/EJ$$

$$L_{GD}^{xo} = \int_0^b (1/2 x/b - 1/2 x^3/b^3) Fb 1/EJ dx = [1/4 x^2/b - 1/8 x^4/b^3]_0^b Fb 1/EJ$$

$$= (1/4 b - 1/8 b) Fb 1/EJ = 1/8 Fb^2/EJ$$

$$L_{DG}^{xo} = \int_0^b (x/b - 3/2 x^2/b^2 + 1/2 x^3/b^3) Fb 1/EJ dx = [1/2 x^2/b - 1/2 x^3/b^2 + 1/8 x^4/b^3]_0^b Fb 1/EJ$$

$$= (1/2 b - 1/2 b + 1/8 b) Fb 1/EJ = 1/8 Fb^2/EJ$$

$$L_{GA}^{xo} = \int_0^b (-1/4 + 1/2 x/b - 1/4 x^2/b^2) Fb 1/EJ dx = [-1/4 x + 1/4 x^2/b - 1/12 x^3/b^2]_0^b Fb 1/EJ$$

$$= (-1/4 b + 1/4 b - 1/12 b) Fb 1/EJ = -1/12 Fb^2/EJ$$

$$L_{AG}^{xo} = \int_0^b (-1/4 x^2/b^2) Fb 1/EJ dx = [-1/12 x^3/b^2]_0^b Fb 1/EJ$$

$$= (-1/12 b) Fb 1/EJ = -1/12 Fb^2/EJ$$

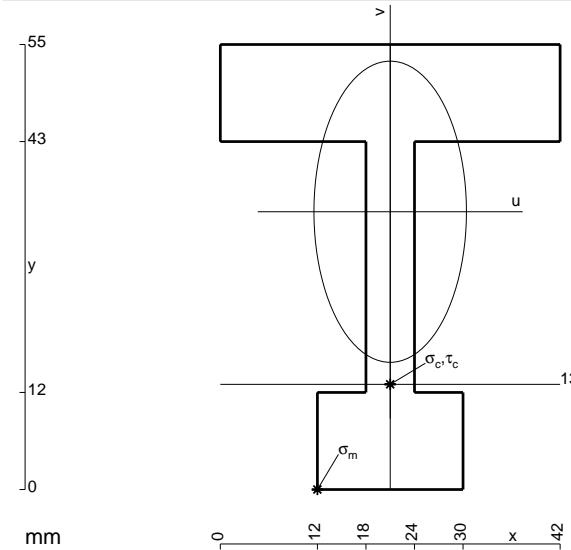

$$A = 906. \text{ mm}^2$$

$$J_u = 314037. \text{ mm}^4$$

$$J_v = 80478. \text{ mm}^4$$

$$y_g = 34.33 \text{ mm}$$

$$T_y = -3800. \text{ N}$$

$$M_x = -2188800. \text{ Nmm}$$

$$x_m = 12. \text{ mm}$$

$$u_m = -9. \text{ mm}$$

$$v_m = -34.33 \text{ mm}$$

$$\sigma_m = -Mv/J_u = -239.3 \text{ N/mm}^2$$

$$x_c = 21. \text{ mm}$$

$$y_c = 13. \text{ mm}$$

$$v_c = -21.33 \text{ mm}$$

$$\sigma_c = -Mv/J_u = -148.7 \text{ N/mm}^2$$

$$\tau_c = 12.61 \text{ N/mm}^2$$

$$\sigma_o = \sqrt{\sigma^2 + 3\tau^2} = 150.3 \text{ N/mm}^2$$

$$S = 6251. \text{ mm}^3$$

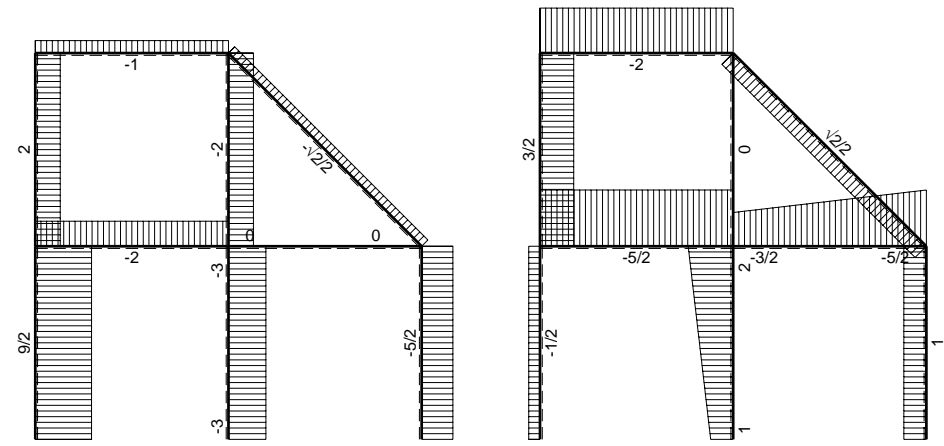
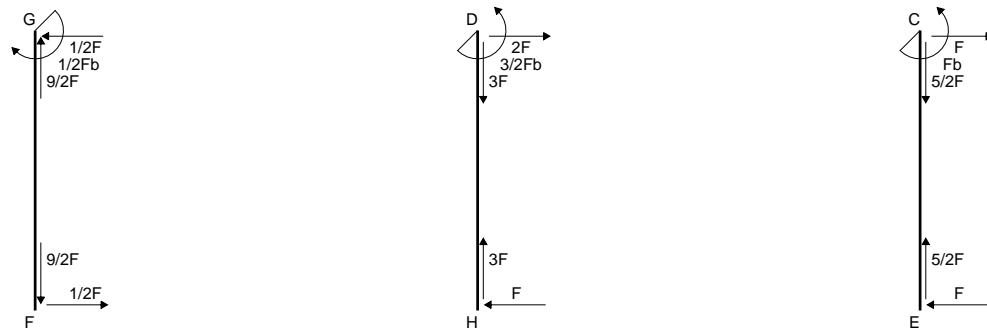
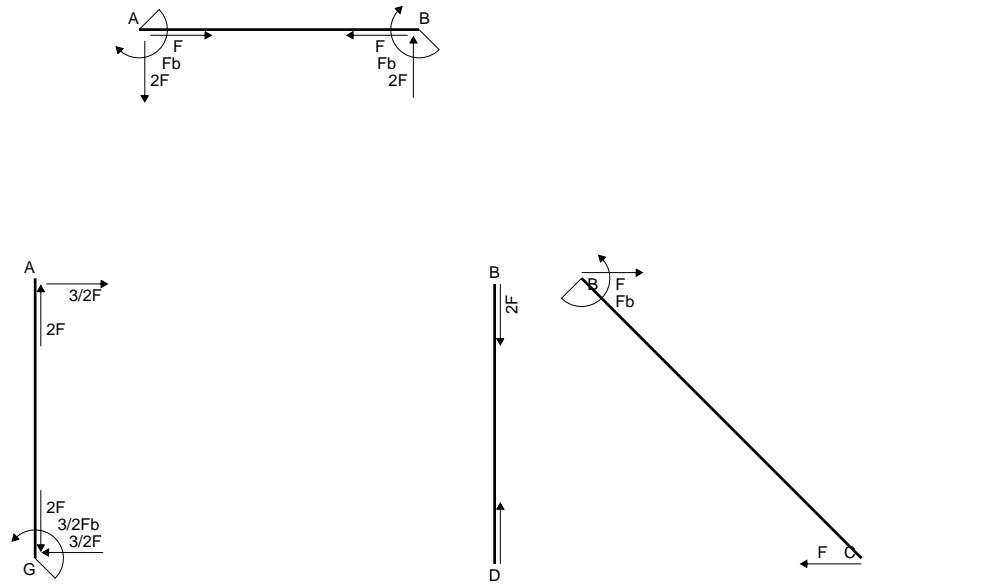

← ⊕ → F

↑ ⊕ ↓ F

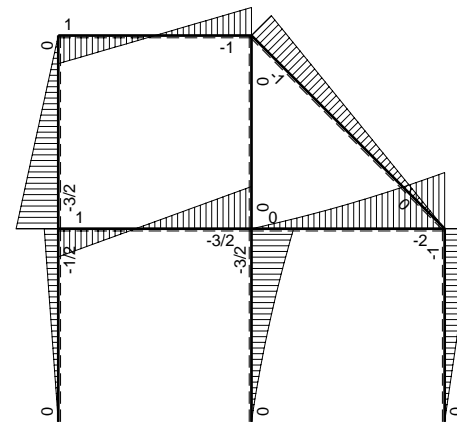

⊕ ⊖ Fb

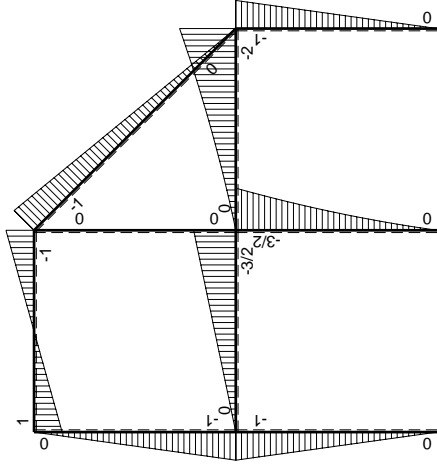
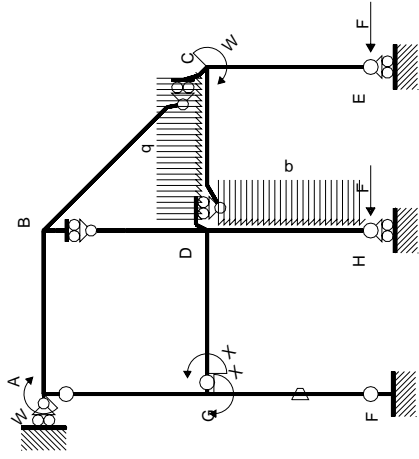

Schema di calcolo iperstatico

M_0 flessione da carichi assegnati

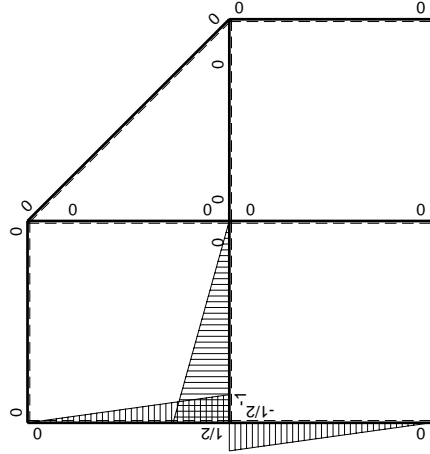

M_1 flessione da iperstatica $X=1$

Quadro contributi PLV per iperstatica $X=W_{GD}$

→	$M_x(x)$	$M_o(x)$	θ	$M_x M_o$	$M_x \theta$	$M_x M_x$	$\int M_x(M_o/EJ+\theta)dx$	$\int X M_x M_x / EJ dx$	
AB b	0	Fb-2Fx	0	0	0	0	0+0	0	
BA b	0	Fb-2Fx	0	0	0	0	0	0	
BC $\sqrt{2}b$	0	-Fb+ $\sqrt{2}/2Fx$	0	0	0	0	0	0	
BD b	0	0	0	0	0	0	0+0	0	
DB b	0	0	0	0	0	0	0	0	
DC b	0	-3/2Fx-1/2qx ²	0	0	0	0	0+0	0	
CD b	0	2Fb-5/2Fx+1/2qx ²	0	0	0	0	0	0	
CE b	0	-Fb+Fx	0	0	0	0	0+0	0	
EC b	0	Fx	0	0	0	0	0	0	
FG b	-1/2x/b	-Fx	-Fb/EJ	1/2Fx ² /b	1/2Fx/EJ	1/4x ² /b ²	(1/6+1/4)Fb ² /EJ	1/12Xb/EJ	
GF b	1/2-1/2x/b	Fb-Fx	Fb/EJ	1/2Fb-Fx+1/2Fx ² /b	1/2Fb/EJ-1/2Fx/EJ	1/4-1/2x/b+1/4x ² /b ²			
GD b	-1+x/b	-3/2Fx	0	3/2Fx-3/2Fx ² /b	0	1-2x/b+x ² /b ²	(1/4+0)Fb ² /EJ	1/3Xb/EJ	
DG b	x/b	3/2Fb-3/2Fx	0	3/2Fx-3/2Fx ² /b	0	x ² /b ²			
DH b	0	-3/2Fb+2Fx-1/2qx ²	0	0	0	0	0+0	0	
HD b	0	Fx+1/2qx ²	0	0	0	0	0	0	
GA b	1/2-1/2x/b	-Fb+Fx	0	-1/2Fb+Fx-1/2Fx ² /b	0	1/4-1/2x/b+1/4x ² /b ²	(-1/6+0)Fb ² /EJ	1/12Xb/EJ	
AG b	-1/2x/b	Fx	0	-1/2Fx ² /b	0	1/4x ² /b ²			
	totali							1/2Fb ² /EJ	1/2Xb/EJ
	iperstatica $X=W_{GD}$							-Fb	

Sviluppi di calcolo iperstatica

$$L_{FG}^{xx} = \int_0^b (1/4 x^2/b^2) 1/EJ dx = [1/12 x^3/b^2]_0^b 1/EJ$$

$$= (1/12 b) 1/EJ = 1/12 b/EJ$$

$$L_{GF}^{xx} = \int_0^b (1/4 - 1/2 x/b + 1/4 x^2/b^2) 1/EJ dx = [1/4 x - 1/4 x^2/b + 1/12 x^3/b^2]_0^b 1/EJ$$

$$= (1/4 b - 1/4 b + 1/12 b) 1/EJ = 1/12 b/EJ$$

$$L_{GD}^{xx} = \int_0^b (1 - 2 x/b + x^2/b^2) 1/EJ dx = [x - x^2/b + 1/3 x^3/b^2]_0^b 1/EJ$$

$$= (b - b + 1/3 b) 1/EJ = 1/3 b/EJ$$

$$L_{DG}^{xx} = \int_0^b (x^2/b^2) 1/EJ dx = [1/3 x^3/b^2]_0^b 1/EJ$$

$$= (1/3 b) 1/EJ = 1/3 b/EJ$$

$$L_{GA}^{xx} = \int_0^b (1/4 - 1/2 x/b + 1/4 x^2/b^2) 1/EJ dx = [1/4 x - 1/4 x^2/b + 1/12 x^3/b^2]_0^b 1/EJ$$

$$= (1/4 b - 1/4 b + 1/12 b) 1/EJ = 1/12 b/EJ$$

$$L_{AG}^{xx} = \int_0^b (1/4 x^2/b^2) 1/EJ dx = [1/12 x^3/b^2]_0^b 1/EJ$$

$$= (1/12 b) 1/EJ = 1/12 b/EJ$$

$$L_{FG}^{x\theta} = \int_0^b (1/2 x^2/b^2) Fb 1/EJ dx + \int_0^b (1/2 x/b) \theta dx = [1/6 x^3/b^2]_0^b Fb 1/EJ + [1/4 x^2/b]_0^b \theta$$

$$= (1/6 b) Fb 1/EJ + (1/4 b) \theta = 5/12 Fb^2/EJ$$

$$L_{GF}^{x\theta} = \int_0^b (1/2 - x/b + 1/2 x^2/b^2) Fb 1/EJ dx + \int_0^b (-1/2 + 1/2 x/b) \theta dx$$

$$= [1/2 x - 1/2 x^2/b + 1/6 x^3/b^2]_0^b Fb 1/EJ + [-1/2 x + 1/4 x^2/b]_0^b \theta$$

$$= (1/2 b - 1/2 b + 1/6 b) Fb 1/EJ + (-1/2 b + 1/4 b) \theta = 5/12 Fb^2/EJ$$

$$L_{GD}^{x\theta} = \int_0^b (3/2 x/b - 3/2 x^2/b^2) Fb 1/EJ dx = [3/4 x^2/b - 1/2 x^3/b^2]_0^b Fb 1/EJ$$

$$= (3/4 b - 1/2 b) Fb 1/EJ = 1/4 Fb^2/EJ$$

$$L_{DG}^{x\theta} = \int_0^b (3/2 x/b - 3/2 x^2/b^2) Fb 1/EJ dx = [3/4 x^2/b - 1/2 x^3/b^2]_0^b Fb 1/EJ$$

$$= (3/4 b - 1/2 b) Fb 1/EJ = 1/4 Fb^2/EJ$$

$$L_{GA}^{x\theta} = \int_0^b (-1/2 + x/b - 1/2 x^2/b^2) Fb 1/EJ dx = [-1/2 x + 1/2 x^2/b - 1/6 x^3/b^2]_0^b Fb 1/EJ$$

$$= (-1/2 b + 1/2 b - 1/6 b) Fb 1/EJ = -1/6 Fb^2/EJ$$

$$L_{AG}^{x\theta} = \int_0^b (-1/2 x^2/b^2) Fb 1/EJ dx = [-1/6 x^3/b^2]_0^b Fb 1/EJ$$

$$= (-1/6 b) Fb 1/EJ = -1/6 Fb^2/EJ$$

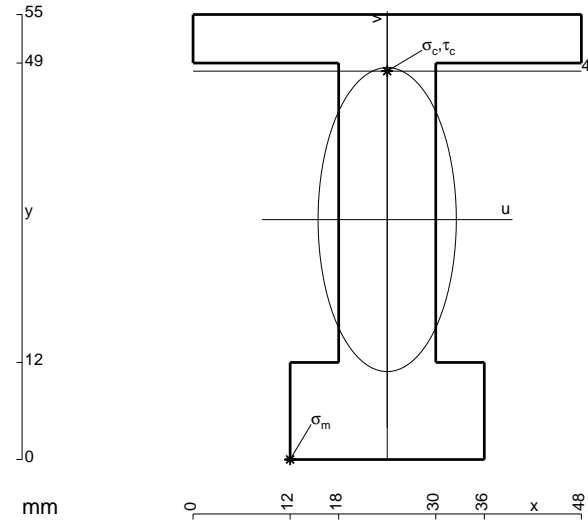

$$A = 1020. \text{ mm}^2$$

$$J_u = 360241. \text{ mm}^4$$

$$J_v = 74448. \text{ mm}^4$$

$$y_g = 29.65 \text{ mm}$$

$$T_y = -3875. \text{ N}$$

$$M_x = -2418000. \text{ Nmm}$$

$$x_m = 12. \text{ mm}$$

$$u_m = -12. \text{ mm}$$

$$v_m = -29.65 \text{ mm}$$

$$\sigma_m = -Mv/J_u = -199. \text{ N/mm}^2$$

$$x_c = 24. \text{ mm}$$

$$y_c = 48. \text{ mm}$$

$$v_c = 18.35 \text{ mm}$$

$$\sigma_c = -Mv/J_u = 123.1 \text{ N/mm}^2$$

$$\tau_c = 5.972 \text{ N/mm}^2$$

$$\sigma_\rho = \sqrt{\sigma^2 + 3\tau^2} = 123.6 \text{ N/mm}^2$$

$$S = 6662. \text{ mm}^3$$

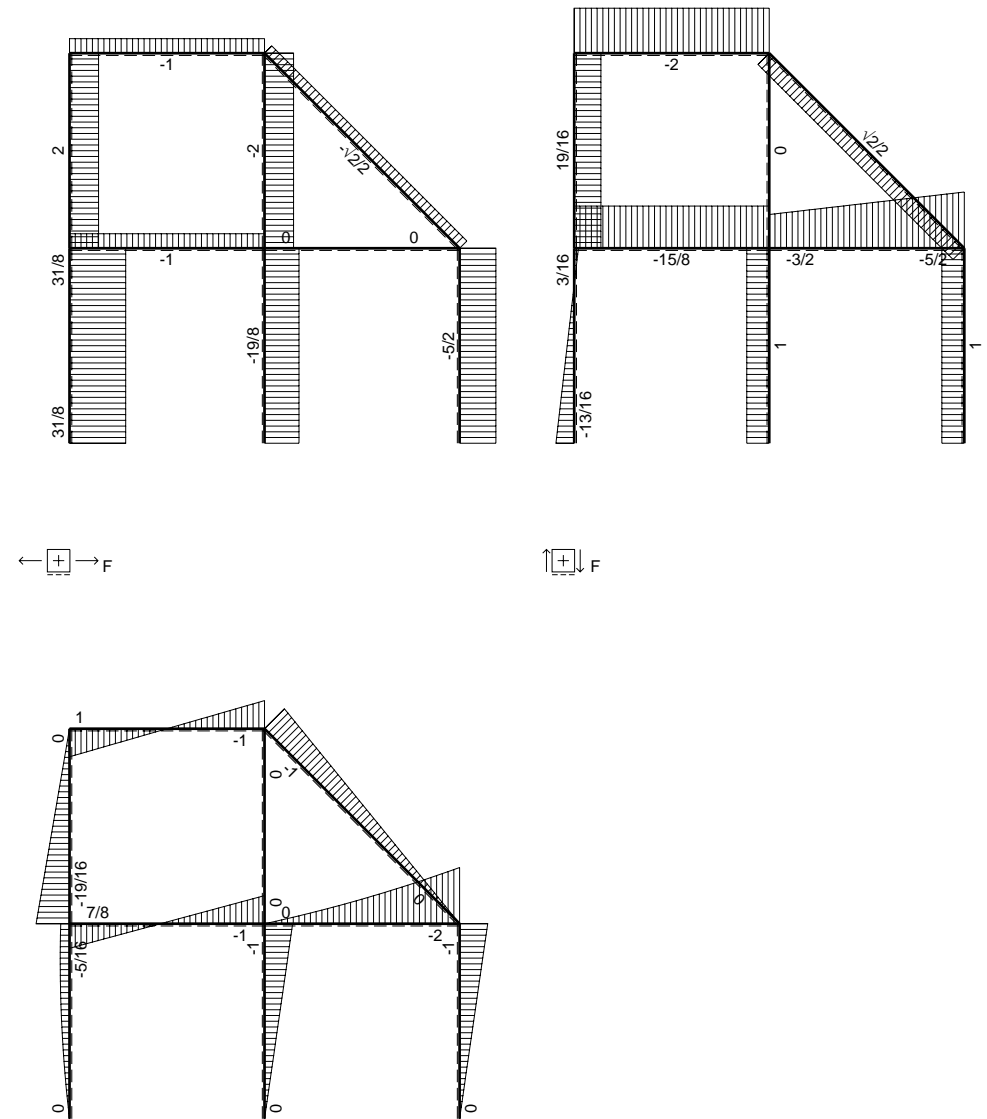
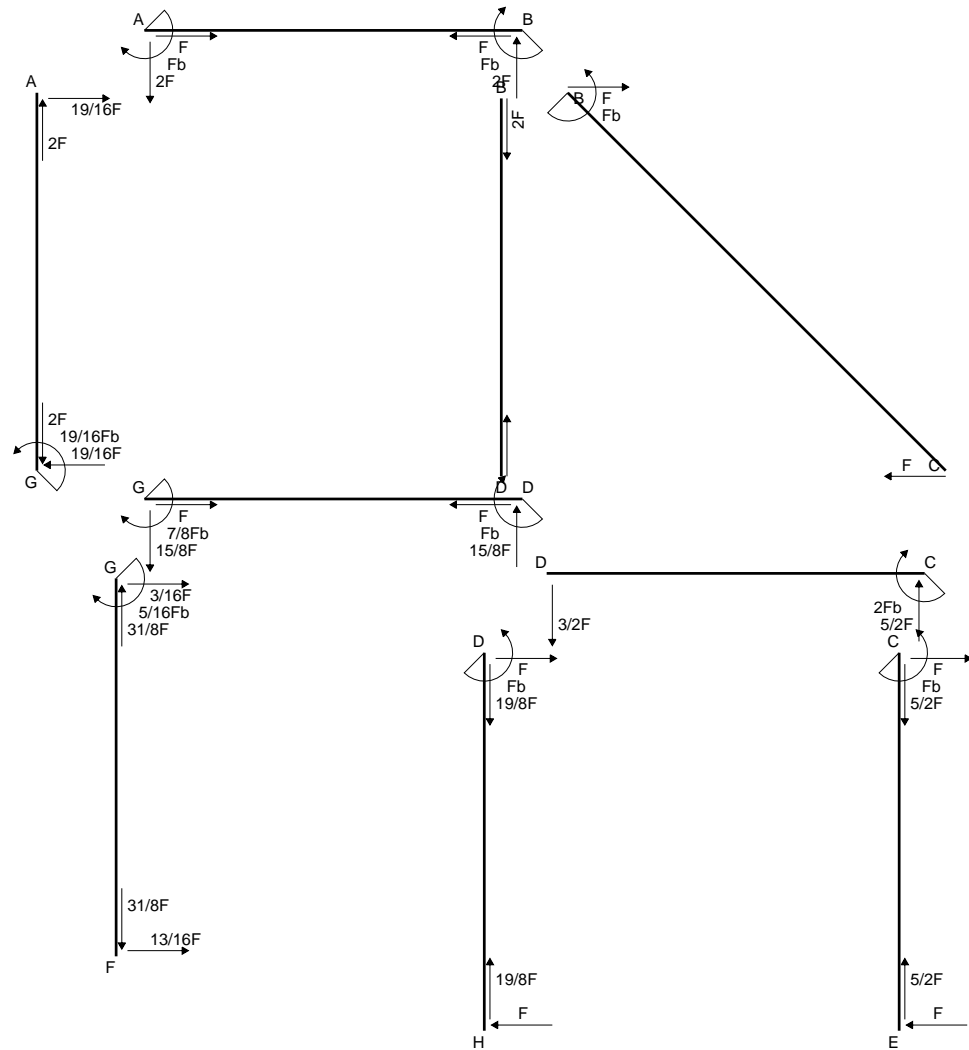

Quadro contributi PLV per iperstatica $X=W_{GD}$

→	$M_x(x)$	$M_o(x)$	θ	$M_x M_o$	$M_x \theta$	$M_x M_x$	$\int M_x(M_o/EJ+\theta)dx$	$\int x M_x M_x/EJ dx$
AB b	0	Fb-2Fx	0	0	0	0	0+0	0
BA b	0	Fb-2Fx	0	0	0	0	0	0
BC $\sqrt{2}b$	0	-Fb+ $\sqrt{2}/2Fx$	0	0	0	0	0	0
BD b	0	0	0	0	0	0	0+0	0
DB b	0	0	0	0	0	0	0	0
DC b	0	-3/2Fx-1/2qx ²	0	0	0	0	0+0	0
CD b	0	2Fb-5/2Fx+1/2qx ²	0	0	0	0	0	0
CE b	0	-Fb+Fx	0	0	0	0	0+0	0
EC b	0	Fx	0	0	0	0	0	0
FG b	-1/2x/b	-5/4Fx+1/2qx ²	-Fb/EJ	5/8Fx ² /b-1/4qx ³ /b	1/2Fx/EJ	1/4x ² /b ²	(7/48+1/4)Fb ² /EJ	1/12Xb/EJ
GF b	1/2-1/2x/b	3/4Fb-1/4Fx-1/2qx ²	Fb/EJ	3/8Fb-1/2Fx-1/8Fx ² /b+1/4qx ³ /b	1/2Fb/EJ-1/2Fx/EJ	1/4-1/2x/b+1/4x ² /b ²		
GD b	-1+x/b	-Fx	0	Fx-Fx ² /b	0	1-2x/b+x ² /b ²	(1/6+0)Fb ² /EJ	1/3Xb/EJ
DG b	x/b	Fb-Fx	0	Fx-Fx ² /b	0	x ² /b ²		
DH b	0	-Fb+Fx	0	0	0	0	0+0	0
HD b	0	Fx	0	0	0	0	0	0
GA b	1/2-1/2x/b	-3/4Fb+3/4Fx	0	-3/8Fb+3/4Fx-3/8Fx ² /b	0	1/4-1/2x/b+1/4x ² /b ²	(-1/8+0)Fb ² /EJ	1/12Xb/EJ
AG b	-1/2x/b	3/4Fx	0	-3/8Fx ² /b	0	1/4x ² /b ²		
	totali						7/16Fb ² /EJ	1/2Xb/EJ
	iperstatica $X=W_{GD}$						-7/8Fb	

Sviluppi di calcolo iperstatica

$$L_{FG}^{xx} = \int_0^b (1/4 x^2/b^2) 1/EJ dx = [1/12 x^3/b^2]_0^b 1/EJ$$

$$= (1/12 b) 1/EJ = 1/12 b/EJ$$

$$L_{GF}^{xx} = \int_0^b (1/4 - 1/2 x/b + 1/4 x^2/b^2) 1/EJ dx = [1/4 x - 1/4 x^2/b + 1/12 x^3/b^2]_0^b 1/EJ$$

$$= (1/4 b - 1/4 b + 1/12 b) 1/EJ = 1/12 b/EJ$$

$$L_{GD}^{xx} = \int_0^b (1 - 2 x/b + x^2/b^2) 1/EJ dx = [x - x^2/b + 1/3 x^3/b^2]_0^b 1/EJ$$

$$= (b - b + 1/3 b) 1/EJ = 1/3 b/EJ$$

$$L_{DG}^{xx} = \int_0^b (x^2/b^2) 1/EJ dx = [1/3 x^3/b^2]_0^b 1/EJ$$

$$= (1/3 b) 1/EJ = 1/3 b/EJ$$

$$L_{GA}^{xx} = \int_0^b (1/4 - 1/2 x/b + 1/4 x^2/b^2) 1/EJ dx = [1/4 x - 1/4 x^2/b + 1/12 x^3/b^2]_0^b 1/EJ$$

$$= (1/4 b - 1/4 b + 1/12 b) 1/EJ = 1/12 b/EJ$$

$$L_{AG}^{xx} = \int_0^b (1/4 x^2/b^2) 1/EJ dx = [1/12 x^3/b^2]_0^b 1/EJ$$

$$= (1/12 b) 1/EJ = 1/12 b/EJ$$

$$L_{FG}^{xo} = \int_0^b (5/8 x^2/b^2 - 1/4 x^3/b^3) Fb 1/EJ dx + \int_0^b (1/2 x/b) \theta dx$$

$$= [5/24 x^3/b^2 - 1/16 x^4/b^3]_0^b Fb 1/EJ + [1/4 x^2/b]_0^b \theta$$

$$= (5/24 b - 1/16 b) Fb 1/EJ + (1/4 b) \theta = 19/48 Fb^2/EJ$$

$$L_{GF}^{xo} = \int_0^b (3/8 - 1/2 x/b - 1/8 x^2/b^2 + 1/4 x^3/b^3) Fb 1/EJ dx + \int_0^b (-1/2 + 1/2 x/b) \theta dx$$

$$= [3/8 x - 1/4 x^2/b - 1/24 x^3/b^2 + 1/16 x^4/b^3]_0^b Fb 1/EJ + [-1/2 x + 1/4 x^2/b]_0^b \theta$$

$$= (3/8 b - 1/4 b - 1/24 b + 1/16 b) Fb 1/EJ + (-1/2 b + 1/4 b) \theta = 19/48 Fb^2/EJ$$

$$L_{GD}^{xo} = \int_0^b (x/b - x^2/b^2) Fb 1/EJ dx = [1/2 x^2/b - 1/3 x^3/b^2]_0^b Fb 1/EJ$$

$$= (1/2 b - 1/3 b) Fb 1/EJ = 1/6 Fb^2/EJ$$

$$L_{DG}^{xo} = \int_0^b (x/b - x^2/b^2) Fb 1/EJ dx = [1/2 x^2/b - 1/3 x^3/b^2]_0^b Fb 1/EJ$$

$$= (1/2 b - 1/3 b) Fb 1/EJ = 1/6 Fb^2/EJ$$

$$L_{GA}^{xo} = \int_0^b (-3/8 + 3/4 x/b - 3/8 x^2/b^2) Fb 1/EJ dx = [-3/8 x + 3/8 x^2/b - 1/8 x^3/b^2]_0^b Fb 1/EJ$$

$$= (-3/8 b + 3/8 b - 1/8 b) Fb 1/EJ = -1/8 Fb^2/EJ$$

$$L_{AG}^{xo} = \int_0^b (-3/8 x^2/b^2) Fb 1/EJ dx = [-1/8 x^3/b^2]_0^b Fb 1/EJ$$

$$= (-1/8 b) Fb 1/EJ = -1/8 Fb^2/EJ$$

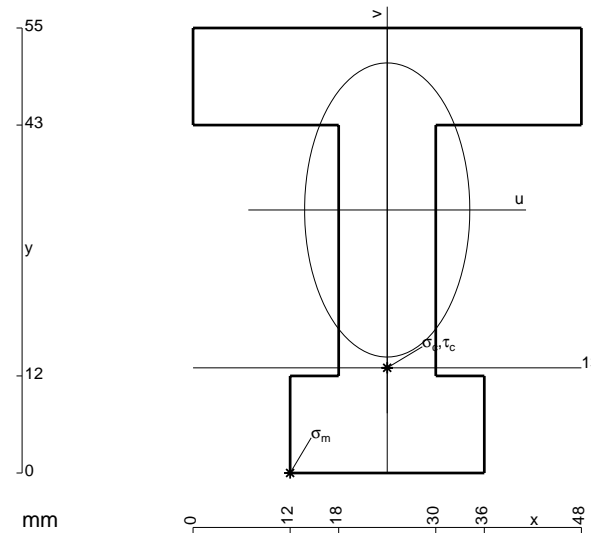

$$A = 1236. \text{ mm}^2$$

$$J_u = 408523. \text{ mm}^4$$

$$J_v = 128880. \text{ mm}^4$$

$$y_g = 32.51 \text{ mm}$$

$$T_y = -3950. \text{ N}$$

$$M_x = -2622800. \text{ Nmm}$$

$$x_m = 12. \text{ mm}$$

$$u_m = -12. \text{ mm}$$

$$v_m = -32.51 \text{ mm}$$

$$\sigma_m = -Mv/J_u = -208.7 \text{ N/mm}^2$$

$$x_c = 24. \text{ mm}$$

$$y_c = 13. \text{ mm}$$

$$v_c = -19.51 \text{ mm}$$

$$\sigma_c = -Mv/J_u = -125.3 \text{ N/mm}^2$$

$$\tau_c = 6.345 \text{ N/mm}^2$$

$$\sigma_o = \sqrt{\sigma^2 + 3\tau^2} = 125.7 \text{ N/mm}^2$$

$$S = 7875. \text{ mm}^3$$

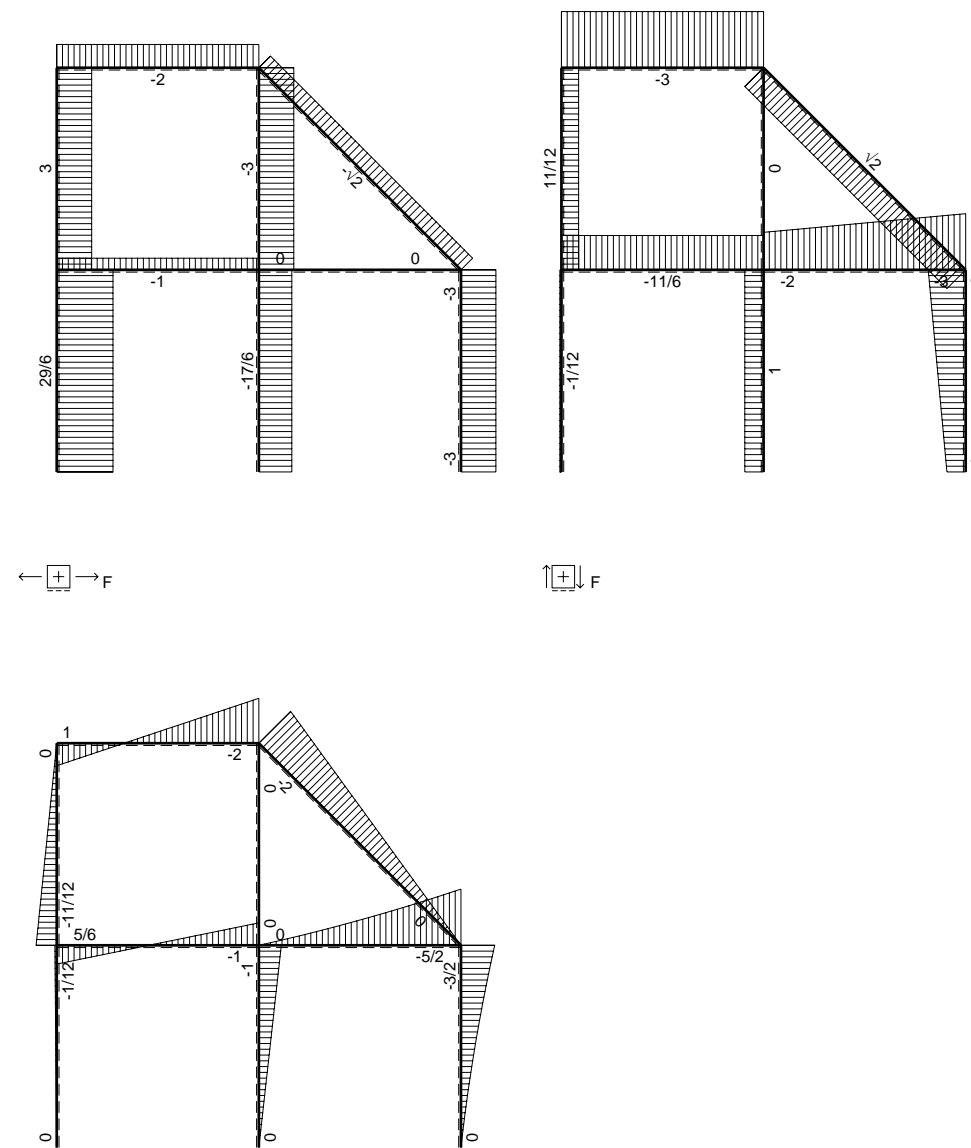
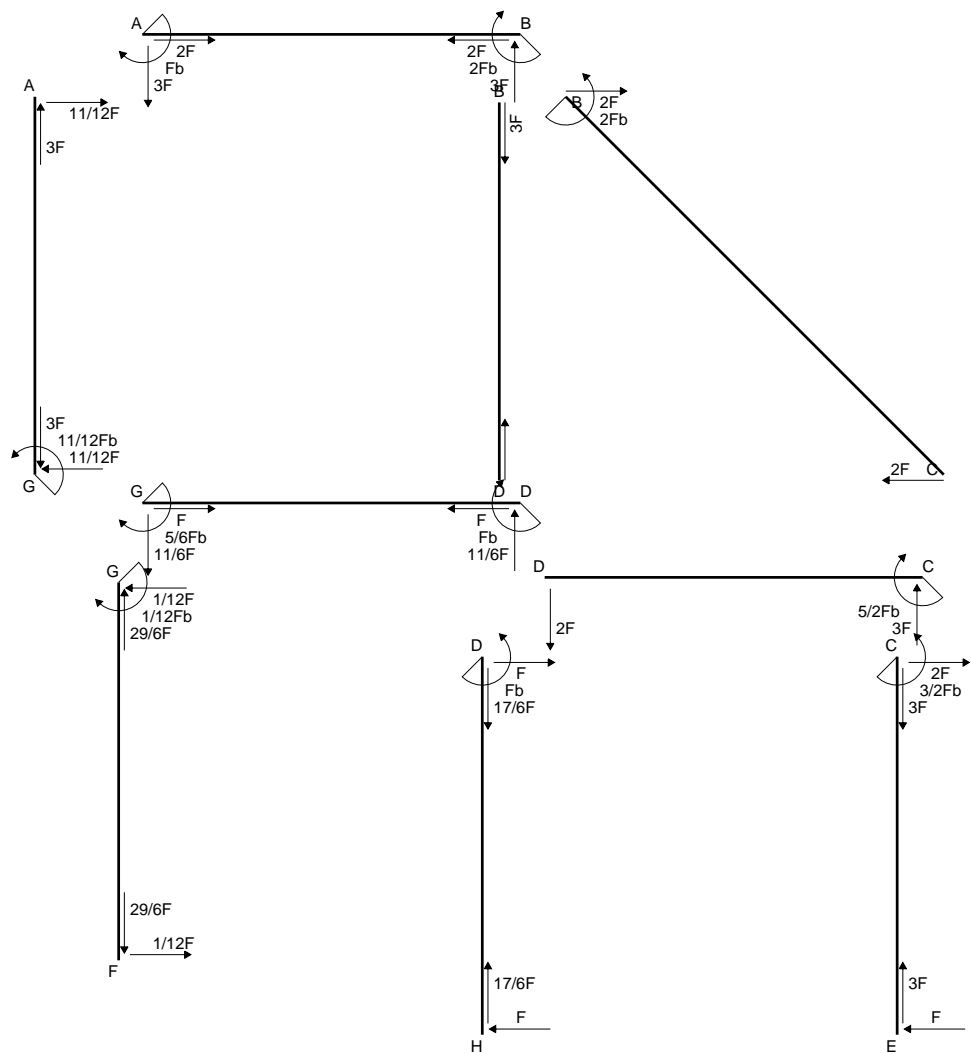

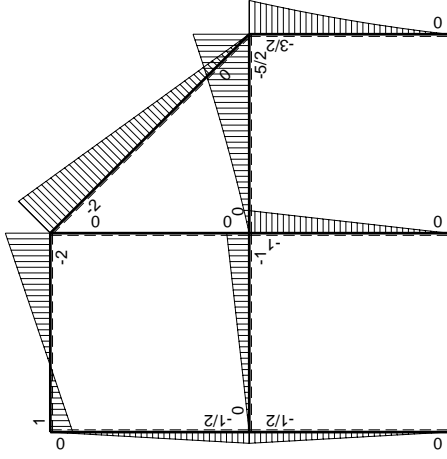
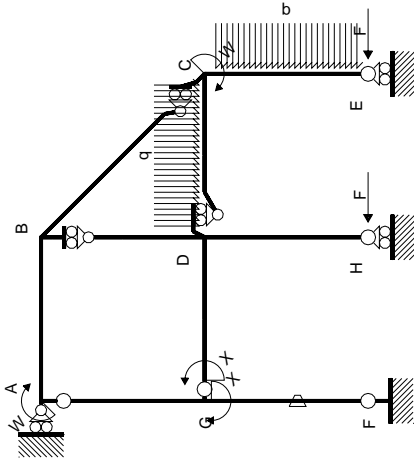

Schema di calcolo iperstatico

M_0 , flessione da carichi assegnati

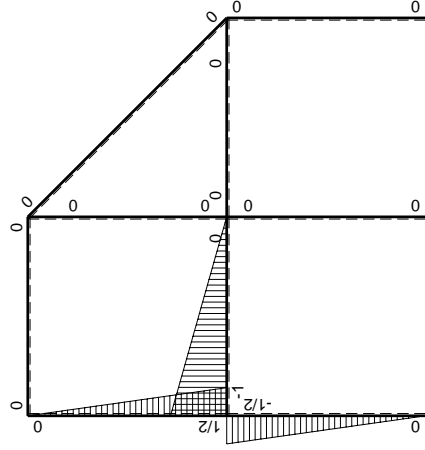

M_x , flessione da iperstatica $X=1$

Quadro contributi PLV per iperstatica $X=W_{GD}$

→	$M_x(x)$	$M_o(x)$	θ	$M_x M_o$	$M_x \theta$	$M_x M_x$	$\int M_x(M_o/EJ+\theta)dx$	$\int X M_x M_x/EJ dx$	
AB b	0	Fb-3Fx	0	0	0	0	0+0	0	
BA b	0	2Fb-3Fx	0	0	0	0			
BC $\sqrt{2}b$	0	-2Fb+ $\sqrt{2}Fx$	0	0	0	0	0	0	
BD b	0	0	0	0	0	0	0+0	0	
DB b	0	0	0	0	0	0			
DC b	0	-2Fx-1/2qx ²	0	0	0	0	0+0	0	
CD b	0	5/2Fb-3Fx+1/2qx ²	0	0	0	0			
CE b	0	-3/2Fb+2Fx-1/2qx ²	0	0	0	0	0+0	0	
EC b	0	Fx+1/2qx ²	0	0	0	0			
FG b	-1/2x/b	-1/2Fx	-Fb/EJ	1/4Fx ² /b	1/2Fx/EJ	1/4x ² /b ²	(1/12+1/4)Fb ² /EJ	1/12Xb/EJ	
GF b	1/2-1/2x/b	1/2Fb-1/2Fx	Fb/EJ	1/4Fb-1/2Fx+1/4Fx ² /b	1/2Fb/EJ-1/2Fx/EJ	1/4-1/2x/b+1/4x ² /b ²			
GD b	-1+x/b	-Fx	0	Fx-Fx ² /b	0	1-2x/b+x ² /b ²	(1/6+0)Fb ² /EJ	1/3Xb/EJ	
DG b	x/b	Fb-Fx	0	Fx-Fx ² /b	0	x ² /b ²			
DH b	0	-Fb+Fx	0	0	0	0	0+0	0	
HD b	0	Fx	0	0	0	0			
GA b	1/2-1/2x/b	-1/2Fb+1/2Fx	0	-1/4Fb+1/2Fx-1/4Fx ² /b	0	1/4-1/2x/b+1/4x ² /b ²	(-1/12+0)Fb ² /EJ	1/12Xb/EJ	
AG b	-1/2x/b	1/2Fx	0	-1/4Fx ² /b	0	1/4x ² /b ²			
	totali							5/12Fb ² /EJ	1/2Xb/EJ
	iperstatica $X=W_{GD}$							-5/6Fb	

Sviluppi di calcolo iperstatica

$$L_{FG}^{xx} = \int_0^b (1/4 x^2/b^2) 1/EJ dx = [1/12 x^3/b^2]_0^b 1/EJ$$

$$= (1/12 b) 1/EJ = 1/12 b/EJ$$

$$L_{GF}^{xx} = \int_0^b (1/4 - 1/2 x/b + 1/4 x^2/b^2) 1/EJ dx = [1/4 x - 1/4 x^2/b + 1/12 x^3/b^2]_0^b 1/EJ$$

$$= (1/4 b - 1/4 b + 1/12 b) 1/EJ = 1/12 b/EJ$$

$$L_{GD}^{xx} = \int_0^b (1 - 2 x/b + x^2/b^2) 1/EJ dx = [x - x^2/b + 1/3 x^3/b^2]_0^b 1/EJ$$

$$= (b - b + 1/3 b) 1/EJ = 1/3 b/EJ$$

$$L_{DG}^{xx} = \int_0^b (x^2/b^2) 1/EJ dx = [1/3 x^3/b^2]_0^b 1/EJ$$

$$= (1/3 b) 1/EJ = 1/3 b/EJ$$

$$L_{GA}^{xx} = \int_0^b (1/4 - 1/2 x/b + 1/4 x^2/b^2) 1/EJ dx = [1/4 x - 1/4 x^2/b + 1/12 x^3/b^2]_0^b 1/EJ$$

$$= (1/4 b - 1/4 b + 1/12 b) 1/EJ = 1/12 b/EJ$$

$$L_{AG}^{xx} = \int_0^b (1/4 x^2/b^2) 1/EJ dx = [1/12 x^3/b^2]_0^b 1/EJ$$

$$= (1/12 b) 1/EJ = 1/12 b/EJ$$

$$L_{FG}^{xo} = \int_0^b (1/4 x^2/b^2) Fb 1/EJ dx + \int_0^b (1/2 x/b) \theta dx = [1/12 x^3/b^2]_0^b Fb 1/EJ + [1/4 x^2/b]_0^b \theta$$

$$= (1/12 b) Fb 1/EJ + (1/4 b) \theta = 1/3 Fb^2/EJ$$

$$L_{GF}^{xo} = \int_0^b (1/4 - 1/2 x/b + 1/4 x^2/b^2) Fb 1/EJ dx + \int_0^b (-1/2 + 1/2 x/b) \theta dx$$

$$= [1/4 x - 1/4 x^2/b + 1/12 x^3/b^2]_0^b Fb 1/EJ + [-1/2 x + 1/4 x^2/b]_0^b \theta$$

$$= (1/4 b - 1/4 b + 1/12 b) Fb 1/EJ + (-1/2 b + 1/4 b) \theta = 1/3 Fb^2/EJ$$

$$L_{GD}^{xo} = \int_0^b (x/b - x^2/b^2) Fb 1/EJ dx = [1/2 x^2/b - 1/3 x^3/b^2]_0^b Fb 1/EJ$$

$$= (1/2 b - 1/3 b) Fb 1/EJ = 1/6 Fb^2/EJ$$

$$L_{DG}^{xo} = \int_0^b (x/b - x^2/b^2) Fb 1/EJ dx = [1/2 x^2/b - 1/3 x^3/b^2]_0^b Fb 1/EJ$$

$$= (1/2 b - 1/3 b) Fb 1/EJ = 1/6 Fb^2/EJ$$

$$L_{GA}^{xo} = \int_0^b (-1/4 + 1/2 x/b - 1/4 x^2/b^2) Fb 1/EJ dx = [-1/4 x + 1/4 x^2/b - 1/12 x^3/b^2]_0^b Fb 1/EJ$$

$$= (-1/4 b + 1/4 b - 1/12 b) Fb 1/EJ = -1/12 Fb^2/EJ$$

$$L_{AG}^{xo} = \int_0^b (-1/4 x^2/b^2) Fb 1/EJ dx = [-1/12 x^3/b^2]_0^b Fb 1/EJ$$

$$= (-1/12 b) Fb 1/EJ = -1/12 Fb^2/EJ$$

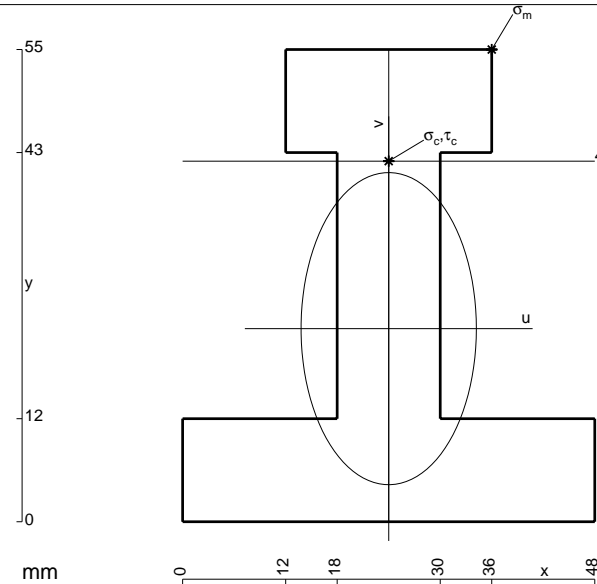

- A = 1236. mm²
- J_u = 408523. mm⁴
- J_v = 128880. mm⁴
- y_g = 22.49 mm
- T_y = -3750. N
- M_x = -2750000. Nmm
- x_m = 36. mm
- y_m = 55. mm
- u_m = 12. mm
- v_m = 32.51 mm
- σ_m = -Mv/J_u = 218.8 N/mm²
- x_c = 24. mm
- y_c = 42. mm
- v_c = 19.51 mm
- σ_c = -Mv/J_u = 131.3 N/mm²
- τ_c = 6.024 N/mm²
- σ_q = √σ²+3τ² = 131.7 N/mm²
- S = 7875. mm³

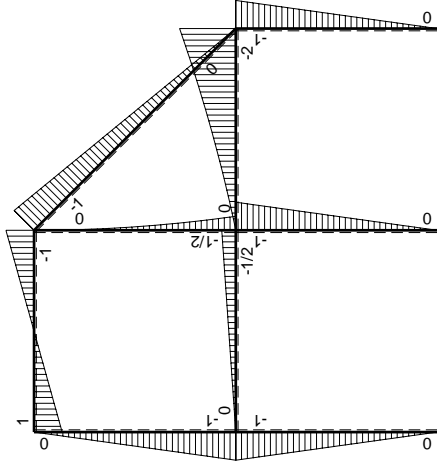
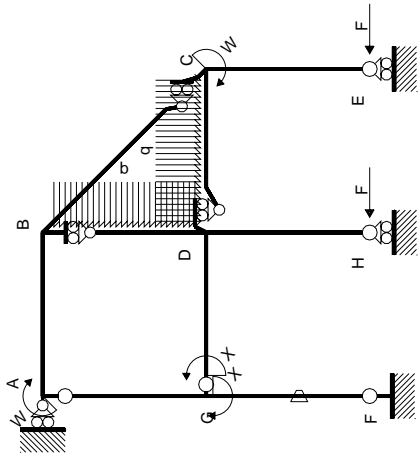

Schema di calcolo iperstatico

M_0 , flessione da carichi assegnati

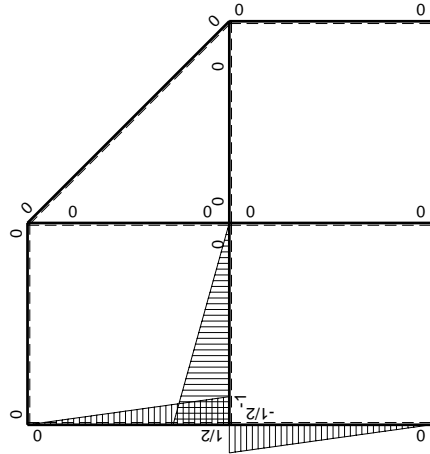

M_x , flessione da iperstatica $X=1$

Quadro contributi PLV per iperstatica $X=W_{GD}$

→	$M_x(x)$	$M_o(x)$	θ	$M_x M_o$	$M_x \theta$	$M_x M_x$	$\int M_x(M_o/EJ+\theta)dx$	$\int x M_x M_x/EJ dx$
AB b	0	Fb-2Fx	0	0	0	0	0+0	0
BA b	0	Fb-2Fx	0	0	0	0		
BC $\sqrt{2}b$	0	-Fb+ $\sqrt{2}/2Fx$	0	0	0	0	0	0
BD b	0	-1/2qx ²	0	0	0	0	0+0	0
DB b	0	1/2Fb-Fx+1/2qx ²	0	0	0	0		
DC b	0	-3/2Fx-1/2qx ²	0	0	0	0	0+0	0
CD b	0	2Fb-5/2Fx+1/2qx ²	0	0	0	0		
CE b	0	-Fb+Fx	0	0	0	0	0+0	0
EC b	0	Fx	0	0	0	0		
FG b	-1/2x/b	-Fx	-Fb/EJ	1/2Fx ² /b	1/2Fx/EJ	1/4x ² /b ²	(1/6+1/4)Fb ² /EJ	1/12Xb/EJ
GF b	1/2-1/2x/b	Fb-Fx	Fb/EJ	1/2Fb-Fx+1/2Fx ² /b	1/2Fb/EJ-1/2Fx/EJ	1/4-1/2x/b+1/4x ² /b ²		
GD b	-1+x/b	-1/2Fx	0	1/2Fx-1/2Fx ² /b	0	1-2x/b+x ² /b ²	(1/12+0)Fb ² /EJ	1/3Xb/EJ
DG b	x/b	1/2Fb-1/2Fx	0	1/2Fx-1/2Fx ² /b	0	x ² /b ²		
DH b	0	-Fb+Fx	0	0	0	0	0+0	0
HD b	0	Fx	0	0	0	0		
GA b	1/2-1/2x/b	-Fb+Fx	0	-1/2Fb+Fx-1/2Fx ² /b	0	1/4-1/2x/b+1/4x ² /b ²	(-1/6+0)Fb ² /EJ	1/12Xb/EJ
AG b	-1/2x/b	Fx	0	-1/2Fx ² /b	0	1/4x ² /b ²		
	totali						1/3Fb ² /EJ	1/2Xb/EJ
	iperstatica $X=W_{GD}$						-2/3Fb	

Sviluppi di calcolo iperstatica

$$L_{FG}^{xx} = \int_0^b (1/4 x^2/b^2) 1/EJ dx = [1/12 x^3/b^2]_0^b 1/EJ$$

$$= (1/12 b) 1/EJ = 1/12 b/EJ$$

$$L_{GF}^{xx} = \int_0^b (1/4 - 1/2 x/b + 1/4 x^2/b^2) 1/EJ dx = [1/4 x - 1/4 x^2/b + 1/12 x^3/b^2]_0^b 1/EJ$$

$$= (1/4 b - 1/4 b + 1/12 b) 1/EJ = 1/12 b/EJ$$

$$L_{GD}^{xx} = \int_0^b (1 - 2 x/b + x^2/b^2) 1/EJ dx = [x - x^2/b + 1/3 x^3/b^2]_0^b 1/EJ$$

$$= (b - b + 1/3 b) 1/EJ = 1/3 b/EJ$$

$$L_{DG}^{xx} = \int_0^b (x^2/b^2) 1/EJ dx = [1/3 x^3/b^2]_0^b 1/EJ$$

$$= (1/3 b) 1/EJ = 1/3 b/EJ$$

$$L_{GA}^{xx} = \int_0^b (1/4 - 1/2 x/b + 1/4 x^2/b^2) 1/EJ dx = [1/4 x - 1/4 x^2/b + 1/12 x^3/b^2]_0^b 1/EJ$$

$$= (1/4 b - 1/4 b + 1/12 b) 1/EJ = 1/12 b/EJ$$

$$L_{AG}^{xx} = \int_0^b (1/4 x^2/b^2) 1/EJ dx = [1/12 x^3/b^2]_0^b 1/EJ$$

$$= (1/12 b) 1/EJ = 1/12 b/EJ$$

$$L_{FG}^{xo} = \int_0^b (1/2 x^2/b^2) Fb 1/EJ dx + \int_0^b (1/2 x/b) \theta dx = [1/6 x^3/b^2]_0^b Fb 1/EJ + [1/4 x^2/b]_0^b \theta$$

$$= (1/6 b) Fb 1/EJ + (1/4 b) \theta = 5/12 Fb^2/EJ$$

$$L_{GF}^{xo} = \int_0^b (1/2 - x/b + 1/2 x^2/b^2) Fb 1/EJ dx + \int_0^b (-1/2 + 1/2 x/b) \theta dx$$

$$= [1/2 x - 1/2 x^2/b + 1/6 x^3/b^2]_0^b Fb 1/EJ + [-1/2 x + 1/4 x^2/b]_0^b \theta$$

$$= (1/2 b - 1/2 b + 1/6 b) Fb 1/EJ + (-1/2 b + 1/4 b) \theta = 5/12 Fb^2/EJ$$

$$L_{GD}^{xo} = \int_0^b (1/2 x/b - 1/2 x^2/b^2) Fb 1/EJ dx = [1/4 x^2/b - 1/6 x^3/b^2]_0^b Fb 1/EJ$$

$$= (1/4 b - 1/6 b) Fb 1/EJ = 1/12 Fb^2/EJ$$

$$L_{DG}^{xo} = \int_0^b (1/2 x/b - 1/2 x^2/b^2) Fb 1/EJ dx = [1/4 x^2/b - 1/6 x^3/b^2]_0^b Fb 1/EJ$$

$$= (1/4 b - 1/6 b) Fb 1/EJ = 1/12 Fb^2/EJ$$

$$L_{GA}^{xo} = \int_0^b (-1/2 + x/b - 1/2 x^2/b^2) Fb 1/EJ dx = [-1/2 x + 1/2 x^2/b - 1/6 x^3/b^2]_0^b Fb 1/EJ$$

$$= (-1/2 b + 1/2 b - 1/6 b) Fb 1/EJ = -1/6 Fb^2/EJ$$

$$L_{AG}^{xo} = \int_0^b (-1/2 x^2/b^2) Fb 1/EJ dx = [-1/6 x^3/b^2]_0^b Fb 1/EJ$$

$$= (-1/6 b) Fb 1/EJ = -1/6 Fb^2/EJ$$

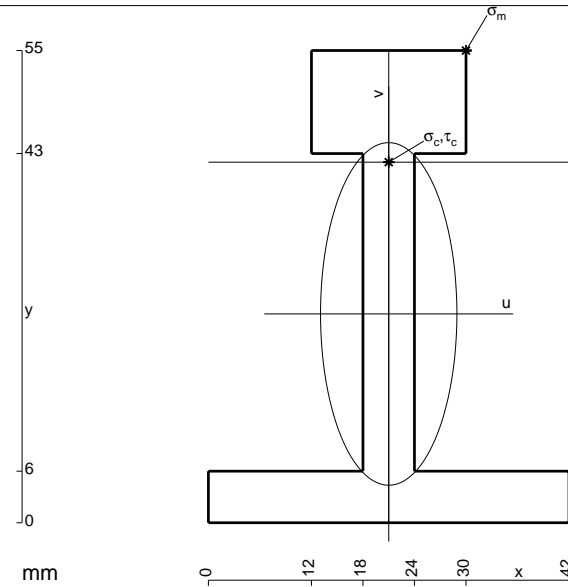

$$A = 690. \text{ mm}^2$$

$$J_u = 274793. \text{ mm}^4$$

$$J_v = 43542. \text{ mm}^4$$

$$y_g = 24.32 \text{ mm}$$

$$T_y = -2750. \text{ N}$$

$$M_x = -2046000. \text{ Nmm}$$

$$x_m = 30. \text{ mm}$$

$$y_m = 55. \text{ mm}$$

$$u_m = 9. \text{ mm}$$

$$v_m = 30.68 \text{ mm}$$

$$\sigma_m = -Mv/J_u = 228.5 \text{ N/mm}^2$$

$$x_c = 21. \text{ mm}$$

$$y_c = 42. \text{ mm}$$

$$v_c = 17.68 \text{ mm}$$

$$\sigma_c = -Mv/J_u = 131.7 \text{ N/mm}^2$$

$$\tau_c = 9.074 \text{ N/mm}^2$$

$$\sigma_q = \sqrt{\sigma^2 + 3\tau^2} = 132.6 \text{ N/mm}^2$$

$$S = 5441. \text{ mm}^3$$

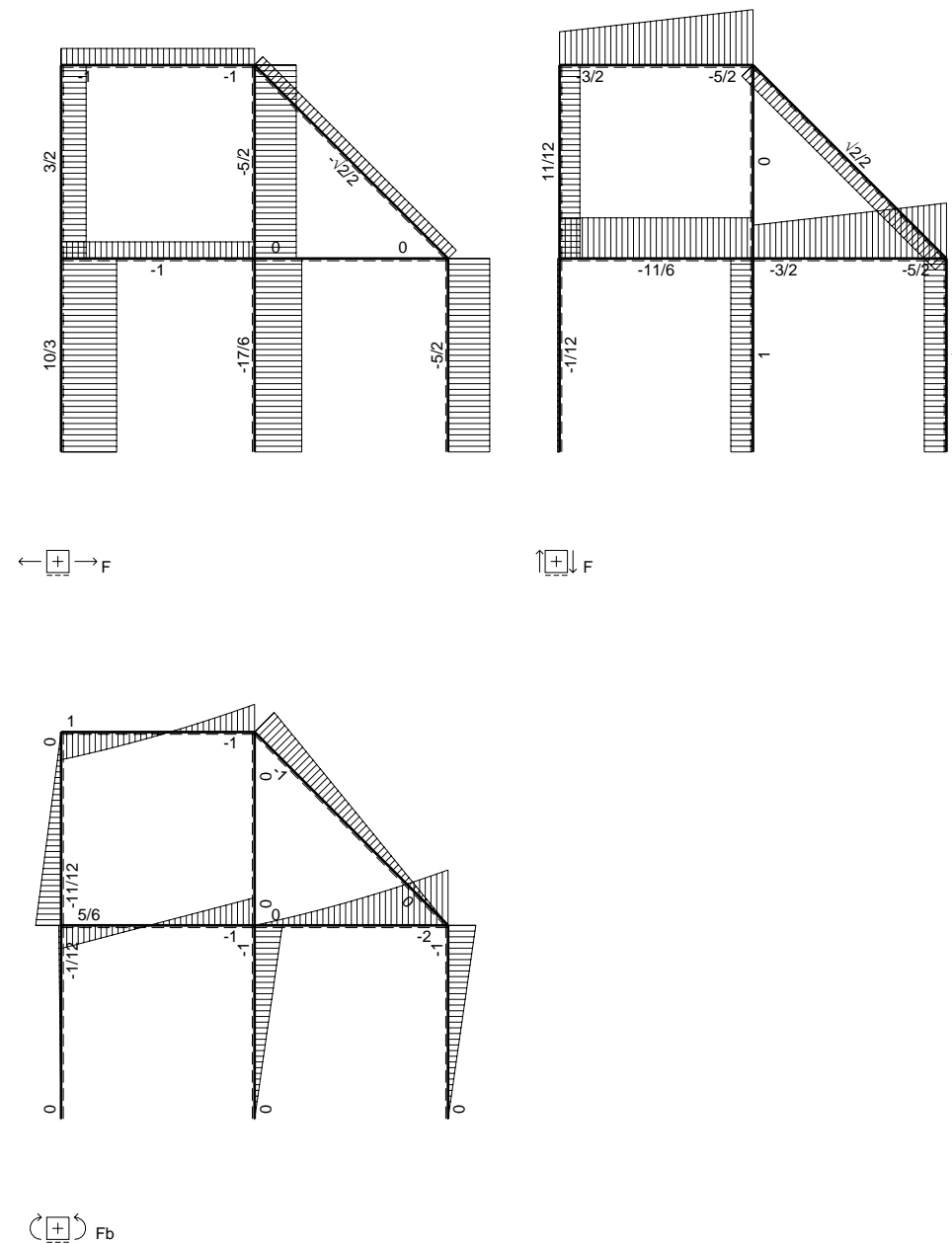
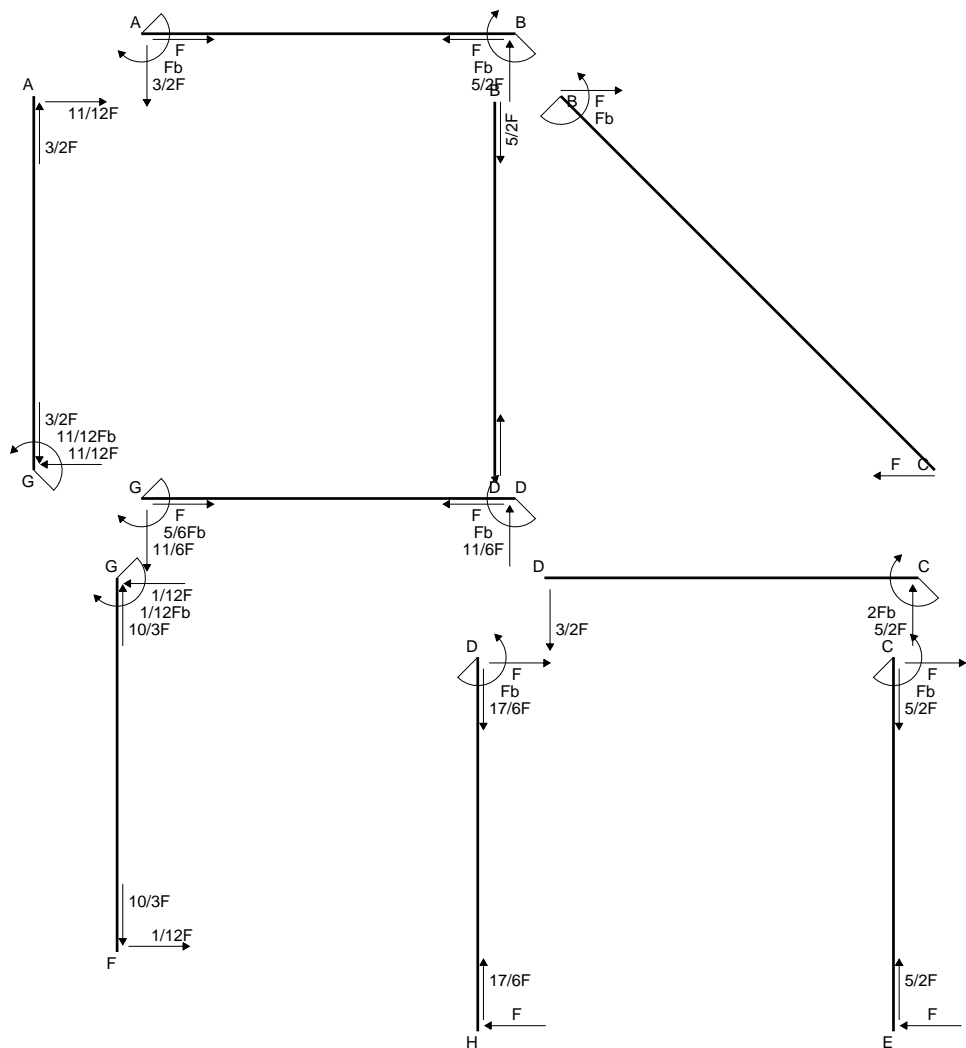

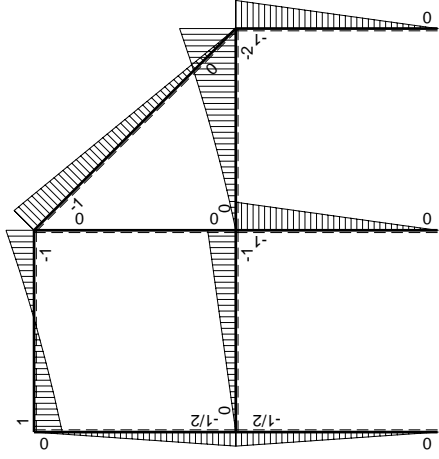
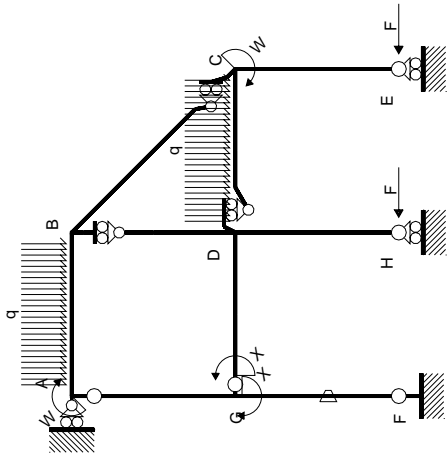

Schema di calcolo iperstatico

M_0 flessione da carichi assegnati

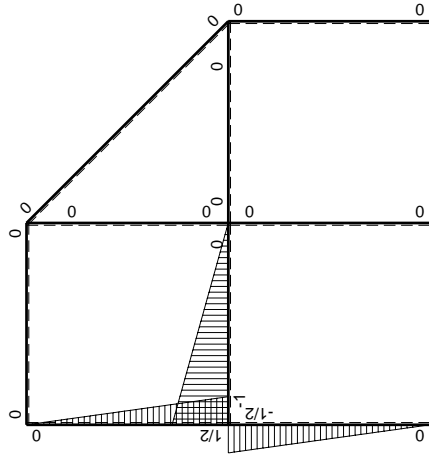

M_X flessione da iperstatica $X=1$

Quadro contributi PLV per iperstatica $X=W_{GD}$

→	$M_x(x)$	$M_o(x)$	θ	$M_x M_o$	$M_x \theta$	$M_x M_x$	$\int M_x(M_o/EJ+\theta)dx$	$\int X M_x M_x/EJ dx$
AB b	0	$Fb-3/2Fx-1/2qx^2$	0	0	0	0	0+0	0
BA b	0	$Fb-5/2Fx+1/2qx^2$	0	0	0	0		
BC $\sqrt{2}b$	0	$-Fb+\sqrt{2}/2Fx$	0	0	0	0	0	0
BD b	0	0	0	0	0	0	0+0	0
DB b	0	0	0	0	0	0		
DC b	0	$-3/2Fx-1/2qx^2$	0	0	0	0	0+0	0
CD b	0	$2Fb-5/2Fx+1/2qx^2$	0	0	0	0		
CE b	0	$-Fb+Fx$	0	0	0	0	0+0	0
EC b	0	Fx	0	0	0	0		
FG b	$-1/2x/b$	$-1/2Fx$	$-Fb/EJ$	$1/4Fx^2/b$	$1/2Fx/EJ$	$1/4x^2/b^2$	$(1/12+1/4)Fb^2/EJ$	$1/12Xb/EJ$
GF b	$1/2-1/2x/b$	$1/2Fb-1/2Fx$	Fb/EJ	$1/4Fb-1/2Fx+1/4Fx^2/b$	$1/2Fb/EJ-1/2Fx/EJ$	$1/4-1/2x/b+1/4x^2/b^2$		
GD b	$-1+x/b$	$-Fx$	0	$Fx-Fx^2/b$	0	$1-2x/b+x^2/b^2$	$(1/6+0)Fb^2/EJ$	$1/3Xb/EJ$
DG b	x/b	$Fb-Fx$	0	$Fx-Fx^2/b$	0	x^2/b^2		
DH b	0	$-Fb+Fx$	0	0	0	0	0+0	0
HD b	0	Fx	0	0	0	0		
GA b	$1/2-1/2x/b$	$-1/2Fb+1/2Fx$	0	$-1/4Fb+1/2Fx-1/4Fx^2/b$	0	$1/4-1/2x/b+1/4x^2/b^2$	$(-1/12+0)Fb^2/EJ$	$1/12Xb/EJ$
AG b	$-1/2x/b$	$1/2Fx$	0	$-1/4Fx^2/b$	0	$1/4x^2/b^2$		
	totali						$5/12Fb^2/EJ$	$1/2Xb/EJ$
	iperstatica $X=W_{GD}$						$-5/6Fb$	

Sviluppi di calcolo iperstatica

$$L_{FG}^{xx} = \int_0^b (1/4 x^2/b^2) 1/EJ dx = [1/12 x^3/b^2]_0^b 1/EJ$$

$$= (1/12 b) 1/EJ = 1/12 b/EJ$$

$$L_{GF}^{xx} = \int_0^b (1/4 - 1/2 x/b + 1/4 x^2/b^2) 1/EJ dx = [1/4 x - 1/4 x^2/b + 1/12 x^3/b^2]_0^b 1/EJ$$

$$= (1/4 b - 1/4 b + 1/12 b) 1/EJ = 1/12 b/EJ$$

$$L_{GD}^{xx} = \int_0^b (1 - 2 x/b + x^2/b^2) 1/EJ dx = [x - x^2/b + 1/3 x^3/b^2]_0^b 1/EJ$$

$$= (b - b + 1/3 b) 1/EJ = 1/3 b/EJ$$

$$L_{DG}^{xx} = \int_0^b (x^2/b^2) 1/EJ dx = [1/3 x^3/b^2]_0^b 1/EJ$$

$$= (1/3 b) 1/EJ = 1/3 b/EJ$$

$$L_{GA}^{xx} = \int_0^b (1/4 - 1/2 x/b + 1/4 x^2/b^2) 1/EJ dx = [1/4 x - 1/4 x^2/b + 1/12 x^3/b^2]_0^b 1/EJ$$

$$= (1/4 b - 1/4 b + 1/12 b) 1/EJ = 1/12 b/EJ$$

$$L_{AG}^{xx} = \int_0^b (1/4 x^2/b^2) 1/EJ dx = [1/12 x^3/b^2]_0^b 1/EJ$$

$$= (1/12 b) 1/EJ = 1/12 b/EJ$$

$$L_{FG}^{xo} = \int_0^b (1/4 x^2/b^2) Fb 1/EJ dx + \int_0^b (1/2 x/b) \theta dx = [1/12 x^3/b^2]_0^b Fb 1/EJ + [1/4 x^2/b]_0^b \theta$$

$$= (1/12 b) Fb 1/EJ + (1/4 b) \theta = 1/3 Fb^2/EJ$$

$$L_{GF}^{xo} = \int_0^b (1/4 - 1/2 x/b + 1/4 x^2/b^2) Fb 1/EJ dx + \int_0^b (-1/2 + 1/2 x/b) \theta dx$$

$$= [1/4 x - 1/4 x^2/b + 1/12 x^3/b^2]_0^b Fb 1/EJ + [-1/2 x + 1/4 x^2/b]_0^b \theta$$

$$= (1/4 b - 1/4 b + 1/12 b) Fb 1/EJ + (-1/2 b + 1/4 b) \theta = 1/3 Fb^2/EJ$$

$$L_{GD}^{xo} = \int_0^b (x/b - x^2/b^2) Fb 1/EJ dx = [1/2 x^2/b - 1/3 x^3/b^2]_0^b Fb 1/EJ$$

$$= (1/2 b - 1/3 b) Fb 1/EJ = 1/6 Fb^2/EJ$$

$$L_{DG}^{xo} = \int_0^b (x/b - x^2/b^2) Fb 1/EJ dx = [1/2 x^2/b - 1/3 x^3/b^2]_0^b Fb 1/EJ$$

$$= (1/2 b - 1/3 b) Fb 1/EJ = 1/6 Fb^2/EJ$$

$$L_{GA}^{xo} = \int_0^b (-1/4 + 1/2 x/b - 1/4 x^2/b^2) Fb 1/EJ dx = [-1/4 x + 1/4 x^2/b - 1/12 x^3/b^2]_0^b Fb 1/EJ$$

$$= (-1/4 b + 1/4 b - 1/12 b) Fb 1/EJ = -1/12 Fb^2/EJ$$

$$L_{AG}^{xo} = \int_0^b (-1/4 x^2/b^2) Fb 1/EJ dx = [-1/12 x^3/b^2]_0^b Fb 1/EJ$$

$$= (-1/12 b) Fb 1/EJ = -1/12 Fb^2/EJ$$

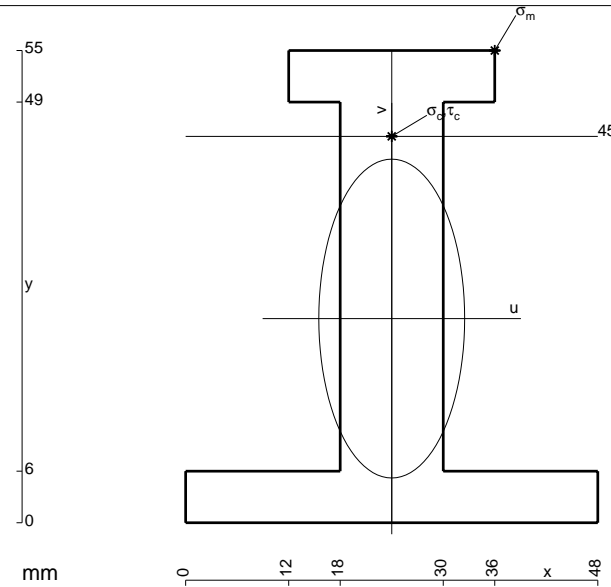

- A = 948. mm²
- J_u = 326982. mm⁴
- J_v = 68400. mm⁴
- y_g = 23.78 mm
- T_y = -3200. N
- M_x = -2508800. Nmm
- x_m = 36. mm
- y_m = 55. mm
- u_m = 12. mm
- v_m = 31.22 mm
- σ_m = -Mv/J_u = 239.6 N/mm²
- x_c = 24. mm
- y_c = 45. mm
- v_c = 21.22 mm
- σ_c = -Mv/J_u = 162.8 N/mm²
- τ_c = 4.223 N/mm²
- σ_ρ = √σ²+3τ² = 163. N/mm²
- S = 5179. mm³

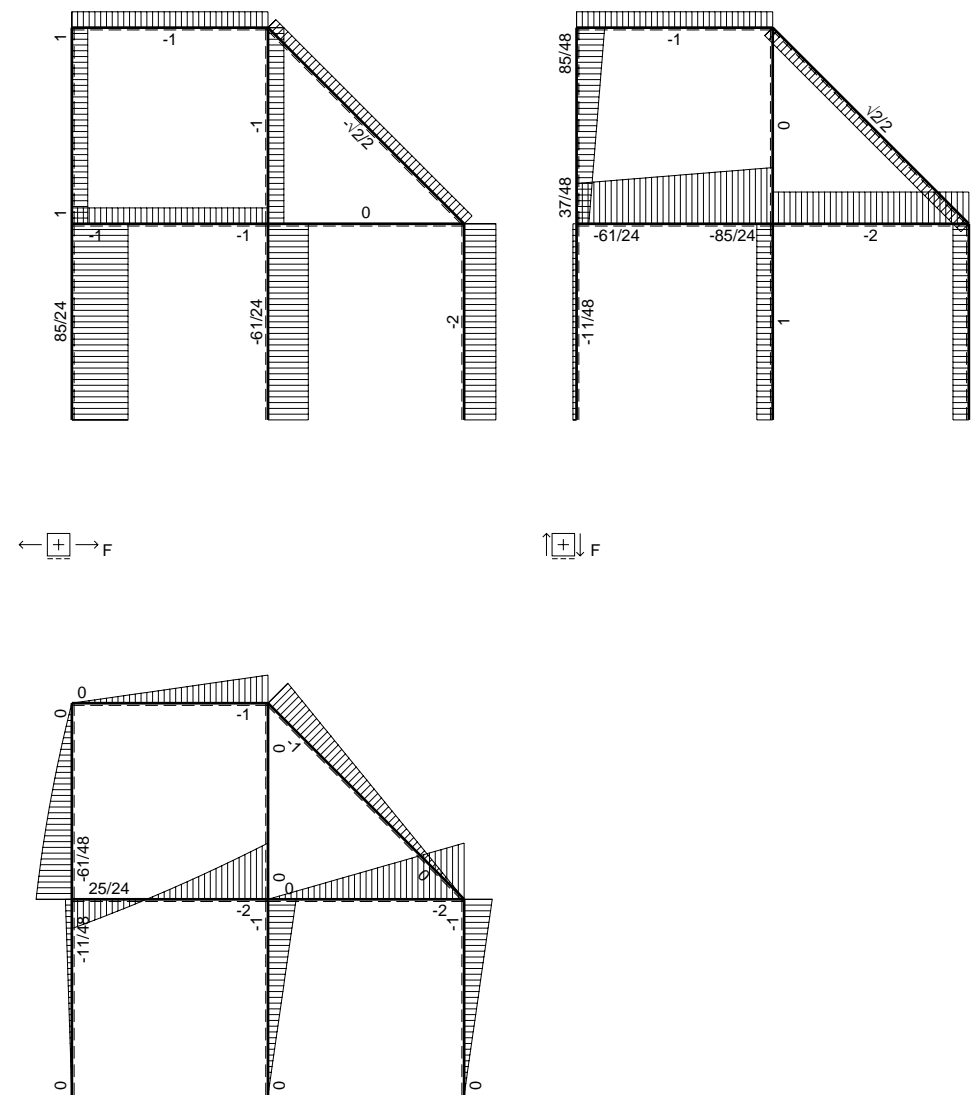
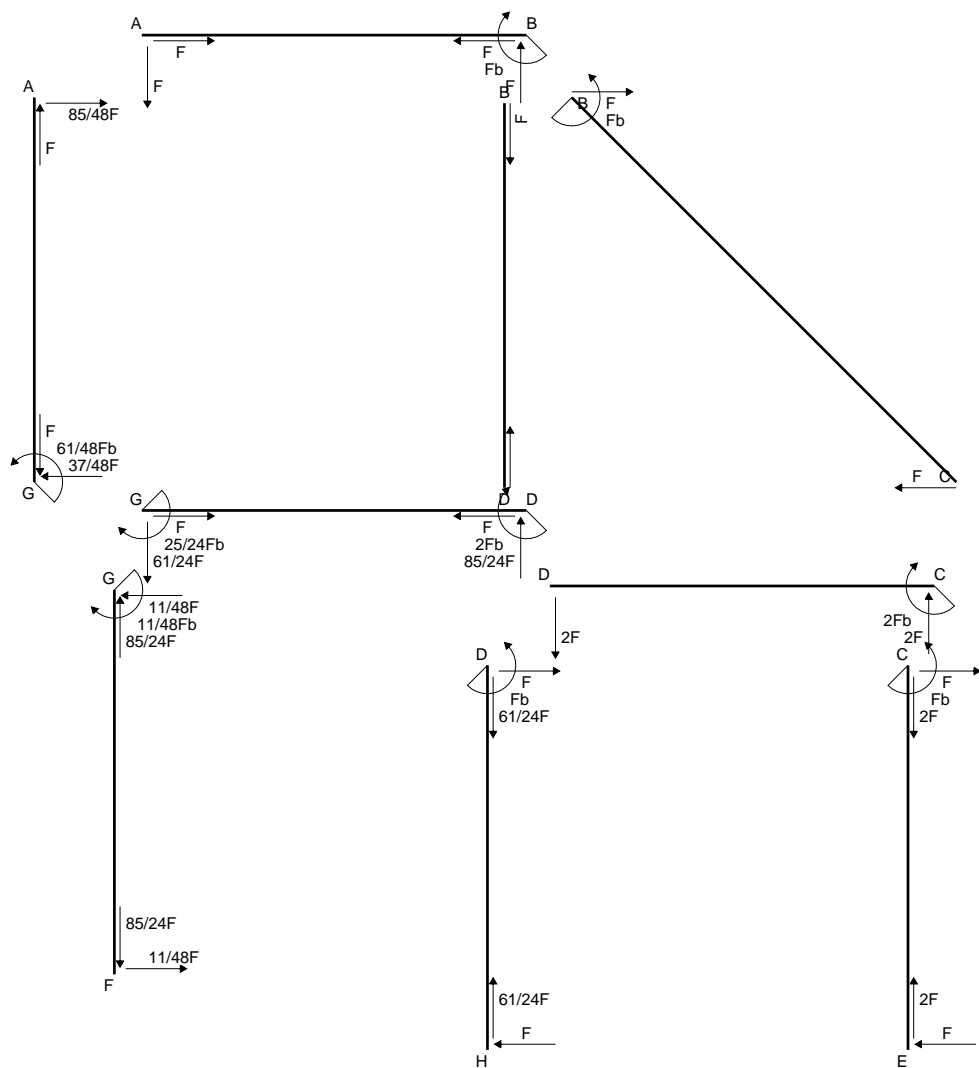

(+) Fb

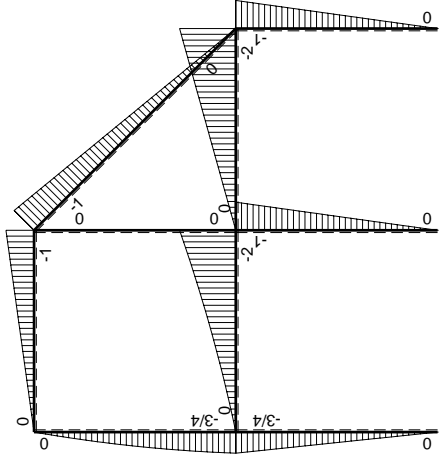
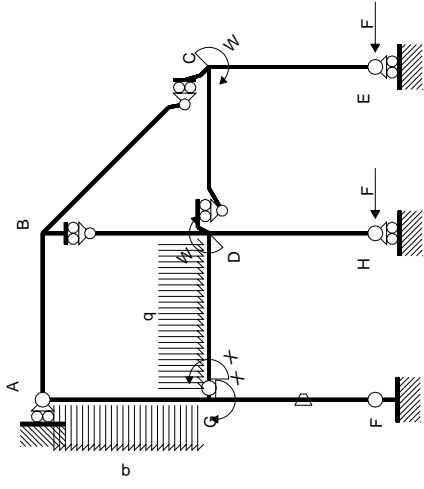

Schema di calcolo iperstatico

M_0 , flessione da carichi assegnati



M_x , flessione da iperstatica $X=1$

Quadro contributi PLV per iperstatica $X=W_{GD}$

→	$M_x(x)$	$M_o(x)$	θ	$M_x M_o$	$M_x \theta$	$M_x M_x$	$\int M_x(M_o/EJ+\theta)dx$	$\int X M_x M_x/EJ dx$
AB b	0	-Fx	0	0	0	0	0+0	0
BA b	0	Fb-Fx	0	0	0	0	0	0
BC $\sqrt{2}b$	0	-Fb+ $\sqrt{2}/2Fx$	0	0	0	0	0	0
BD b	0	0	0	0	0	0	0+0	0
DB b	0	0	0	0	0	0	0	0
DC b	0	-2Fx	0	0	0	0	0+0	0
CD b	0	2Fb-2Fx	0	0	0	0	0	0
CE b	0	-Fb+Fx	0	0	0	0	0+0	0
EC b	0	Fx	0	0	0	0	0	0
FG b	-1/2x/b	-3/4Fx	-Fb/EJ	$3/8Fx^2/b$	$1/2Fx/EJ$	$1/4x^2/b^2$	$(1/8+1/4)Fb^2/EJ$	$1/12Xb/EJ$
GF b	$1/2-1/2x/b$	$3/4Fb-3/4Fx$	Fb/EJ	$3/8Fb-3/4Fx+3/8Fx^2/b$	$1/2Fb/EJ-1/2Fx/EJ$	$1/4-1/2x/b+1/4x^2/b^2$	$(1/8+1/4)Fb^2/EJ$	$1/12Xb/EJ$
GD b	-1+x/b	$-3/2Fx-1/2qx^2$	0	$3/2Fx-Fx^2/b-1/2qx^3/b$	0	$1-2x/b+x^2/b^2$	$(7/24+0)Fb^2/EJ$	$1/3Xb/EJ$
DG b	x/b	$2Fb-5/2Fx+1/2qx^2$	0	$2Fx-5/2Fx^2/b+1/2qx^3/b$	0	x^2/b^2	$(7/24+0)Fb^2/EJ$	$1/3Xb/EJ$
DH b	0	-Fb+Fx	0	0	0	0	0+0	0
HD b	0	Fx	0	0	0	0	0	0
GA b	$1/2-1/2x/b$	$-3/4Fb+1/4Fx+1/2qx^2$	0	$-3/8Fb+1/2Fx+1/8Fx^2/b-1/4qx^3/b$	0	$1/4-1/2x/b+1/4x^2/b^2$	$(-7/48+0)Fb^2/EJ$	$1/12Xb/EJ$
AG b	-1/2x/b	$5/4Fx-1/2qx^2$	0	$-5/8Fx^2/b+1/4qx^3/b$	0	$1/4x^2/b^2$	$(-7/48+0)Fb^2/EJ$	$1/12Xb/EJ$
	totali						$25/48Fb^2/EJ$	$1/2Xb/EJ$
	iperstatica $X=W_{GD}$						-25/24Fb	

Sviluppi di calcolo iperstatica

$$L_{FG}^{xx} = \int_0^b (1/4 x^2/b^2) 1/EJ dx = [1/12 x^3/b^2]_0^b 1/EJ$$

$$= (1/12 b) 1/EJ = 1/12 b/EJ$$

$$L_{GF}^{xx} = \int_0^b (1/4 - 1/2 x/b + 1/4 x^2/b^2) 1/EJ dx = [1/4 x - 1/4 x^2/b + 1/12 x^3/b^2]_0^b 1/EJ$$

$$= (1/4 b - 1/4 b + 1/12 b) 1/EJ = 1/12 b/EJ$$

$$L_{GD}^{xx} = \int_0^b (1 - 2 x/b + x^2/b^2) 1/EJ dx = [x - x^2/b + 1/3 x^3/b^2]_0^b 1/EJ$$

$$= (b - b + 1/3 b) 1/EJ = 1/3 b/EJ$$

$$L_{DG}^{xx} = \int_0^b (x^2/b^2) 1/EJ dx = [1/3 x^3/b^2]_0^b 1/EJ$$

$$= (1/3 b) 1/EJ = 1/3 b/EJ$$

$$L_{GA}^{xx} = \int_0^b (1/4 - 1/2 x/b + 1/4 x^2/b^2) 1/EJ dx = [1/4 x - 1/4 x^2/b + 1/12 x^3/b^2]_0^b 1/EJ$$

$$= (1/4 b - 1/4 b + 1/12 b) 1/EJ = 1/12 b/EJ$$

$$L_{AG}^{xx} = \int_0^b (1/4 x^2/b^2) 1/EJ dx = [1/12 x^3/b^2]_0^b 1/EJ$$

$$= (1/12 b) 1/EJ = 1/12 b/EJ$$

$$L_{FG}^{xo} = \int_0^b (3/8 x^2/b^2) Fb 1/EJ dx + \int_0^b (1/2 x/b) \theta dx = [1/8 x^3/b^2]_0^b Fb 1/EJ + [1/4 x^2/b]_0^b \theta$$

$$= (1/8 b) Fb 1/EJ + (1/4 b) \theta = 3/8 Fb^2/EJ$$

$$L_{GF}^{xo} = \int_0^b (3/8 - 3/4 x/b + 3/8 x^2/b^2) Fb 1/EJ dx + \int_0^b (-1/2 + 1/2 x/b) \theta dx$$

$$= [3/8 x - 3/8 x^2/b + 1/8 x^3/b^2]_0^b Fb 1/EJ + [-1/2 x + 1/4 x^2/b]_0^b \theta$$

$$= (3/8 b - 3/8 b + 1/8 b) Fb 1/EJ + (-1/2 b + 1/4 b) \theta = 3/8 Fb^2/EJ$$

$$L_{GD}^{xo} = \int_0^b (3/2 x/b - x^2/b^2 - 1/2 x^3/b^3) Fb 1/EJ dx = [3/4 x^2/b - 1/3 x^3/b^2 - 1/8 x^4/b^3]_0^b Fb 1/EJ$$

$$= (3/4 b - 1/3 b - 1/8 b) Fb 1/EJ = 7/24 Fb^2/EJ$$

$$L_{DG}^{xo} = \int_0^b (2 x/b - 5/2 x^2/b^2 + 1/2 x^3/b^3) Fb 1/EJ dx = [x^2/b - 5/6 x^3/b^2 + 1/8 x^4/b^3]_0^b Fb 1/EJ$$

$$= (b - 5/6 b + 1/8 b) Fb 1/EJ = 7/24 Fb^2/EJ$$

$$L_{GA}^{xo} = \int_0^b (-3/8 + 1/2 x/b + 1/8 x^2/b^2 - 1/4 x^3/b^3) Fb 1/EJ dx$$

$$= [-3/8 x + 1/4 x^2/b + 1/24 x^3/b^2 - 1/16 x^4/b^3]_0^b Fb 1/EJ$$

$$= (-3/8 b + 1/4 b + 1/24 b - 1/16 b) Fb 1/EJ = -7/48 Fb^2/EJ$$

$$L_{AG}^{xo} = \int_0^b (-5/8 x^2/b^2 + 1/4 x^3/b^3) Fb 1/EJ dx = [-5/24 x^3/b^2 + 1/16 x^4/b^3]_0^b Fb 1/EJ$$

$$= (-5/24 b + 1/16 b) Fb 1/EJ = -7/48 Fb^2/EJ$$

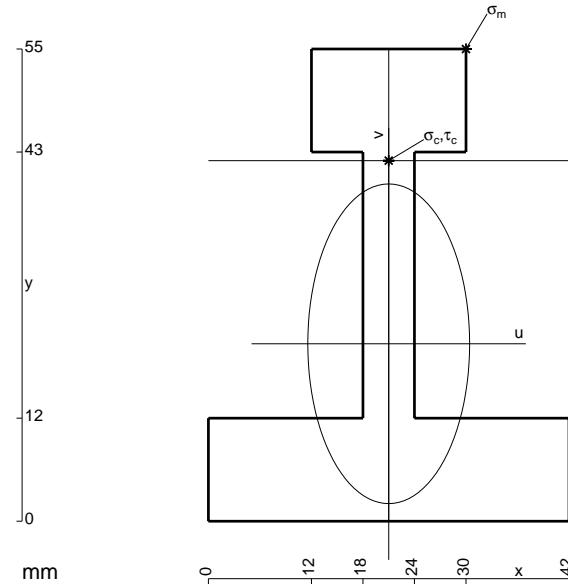

- A = 906. mm²
- J_u = 314037. mm⁴
- J_v = 80478. mm⁴
- y_g = 20.67 mm
- T_y = -3500. N
- M_x = -1820000. Nmm
- x_m = 30. mm
- y_m = 55. mm
- u_m = 9. mm
- v_m = 34.33 mm
- σ_m = -Mv/J_u = 199. N/mm²
- x_c = 21. mm
- y_c = 42. mm
- v_c = 21.33 mm
- σ_c = -Mv/J_v = 123.6 N/mm²
- τ_c = 11.61 N/mm²
- σ_o = √σ²+3τ² = 125.3 N/mm²
- S = 6251. mm³

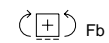
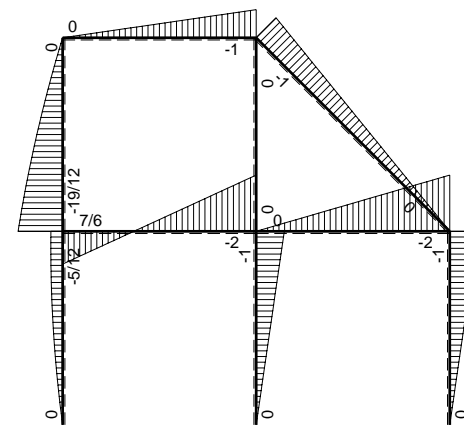
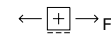
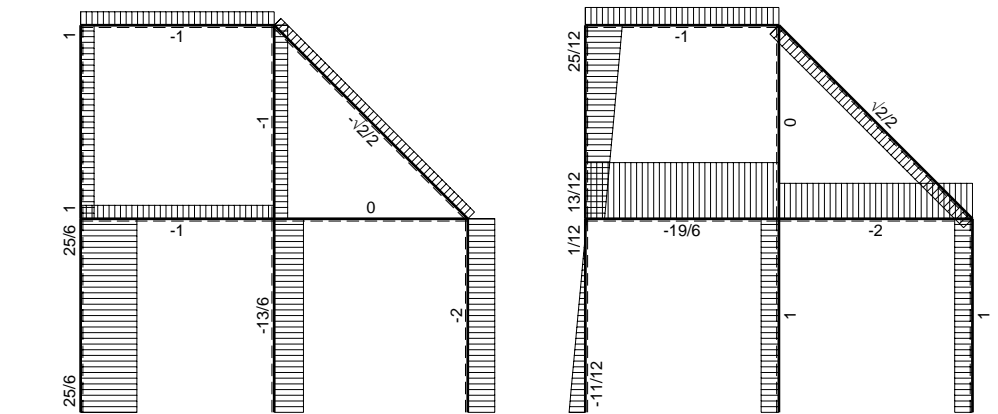
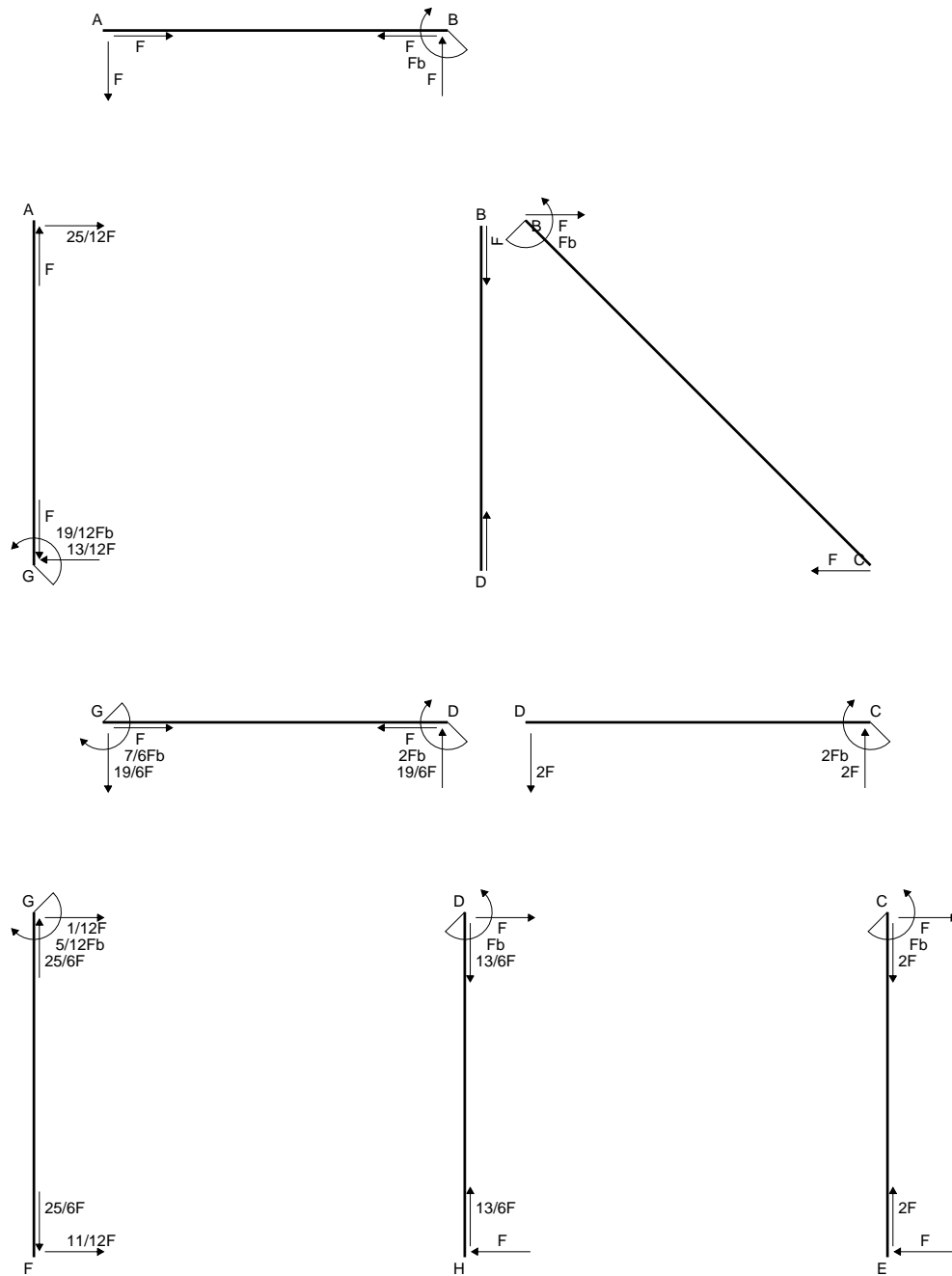

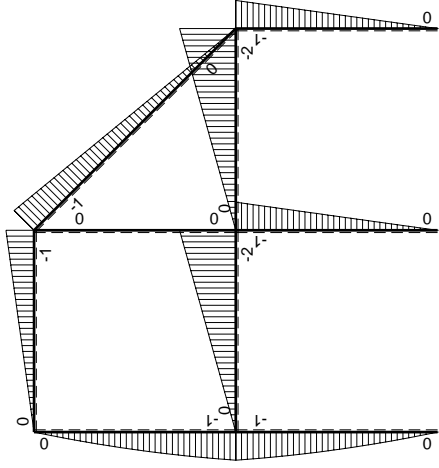
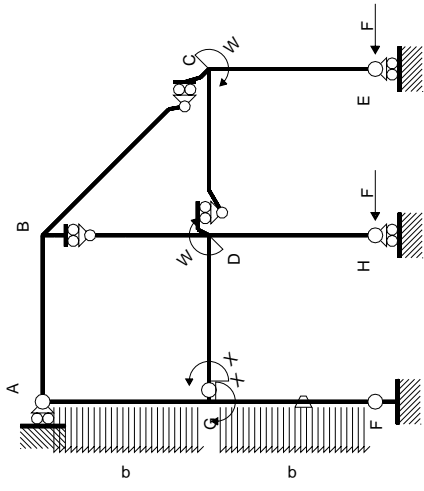

Schema di calcolo iperstatico

M_0 flessione da carichi assegnati

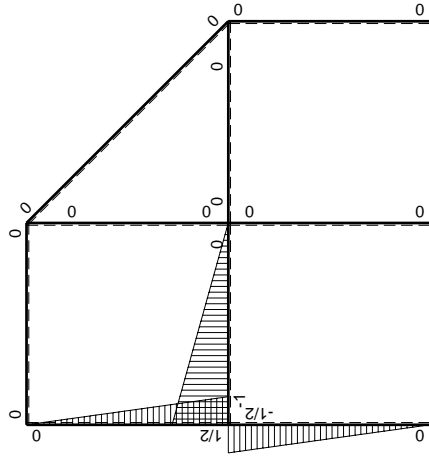

M_X flessione da iperstatica $X=1$

Quadro contributi PLV per iperstatica $X=W_{GD}$

→	$M_x(x)$	$M_o(x)$	θ	$M_x M_o$	$M_x \theta$	$M_x M_x$	$\int M_x(M_o/EJ+\theta)dx$	$\int X M_x M_x/EJ dx$
AB b	0	-Fx	0	0	0	0	0+0	0
BA b	0	Fb-Fx	0	0	0	0		
BC $\sqrt{2}b$	0	-Fb+ $\sqrt{2}/2Fx$	0	0	0	0	0	0
BD b	0	0	0	0	0	0	0+0	0
DB b	0	0	0	0	0	0		
DC b	0	-2Fx	0	0	0	0	0+0	0
CD b	0	2Fb-2Fx	0	0	0	0		
CE b	0	-Fb+Fx	0	0	0	0	0+0	0
EC b	0	Fx	0	0	0	0		
FG b	-1/2x/b	-3/2Fx+1/2qx ²	-Fb/EJ	3/4Fx ² /b-1/4qx ³ /b	1/2Fx/EJ	1/4x ² /b ²	(3/16+1/4)Fb ² /EJ	1/12Xb/EJ
GF b	1/2-1/2x/b	Fb-1/2Fx-1/2qx ²	Fb/EJ	1/2Fb-3/4Fx+1/4qx ³ /b	1/2Fb/EJ-1/2Fx/EJ	1/4-1/2x/b+1/4x ² /b ²		
GD b	-1+x/b	-2Fx	0	2Fx-2Fx ² /b	0	1-2x/b+x ² /b ²	(1/3+0)Fb ² /EJ	1/3Xb/EJ
DG b	x/b	2Fb-2Fx	0	2Fx-2Fx ² /b	0	x ² /b ²		
DH b	0	-Fb+Fx	0	0	0	0	0+0	0
HD b	0	Fx	0	0	0	0		
GA b	1/2-1/2x/b	-Fb+1/2Fx+1/2qx ²	0	-1/2Fb+3/4Fx-1/4qx ³ /b	0	1/4-1/2x/b+1/4x ² /b ²	(-3/16+0)Fb ² /EJ	1/12Xb/EJ
AG b	-1/2x/b	3/2Fx-1/2qx ²	0	-3/4Fx ² /b+1/4qx ³ /b	0	1/4x ² /b ²		
	totali						7/12Fb ² /EJ	1/2Xb/EJ
	iperstatica $X=W_{GD}$						-7/6Fb	

Sviluppi di calcolo iperstatica

$$L_{FG}^{xx} = \int_0^b (1/4 x^2/b^2) 1/EJ dx = [1/12 x^3/b^2]_0^b 1/EJ$$

$$= (1/12 b) 1/EJ = 1/12 b/EJ$$

$$L_{GF}^{xx} = \int_0^b (1/4 - 1/2 x/b + 1/4 x^2/b^2) 1/EJ dx = [1/4 x - 1/4 x^2/b + 1/12 x^3/b^2]_0^b 1/EJ$$

$$= (1/4 b - 1/4 b + 1/12 b) 1/EJ = 1/12 b/EJ$$

$$L_{GD}^{xx} = \int_0^b (1 - 2 x/b + x^2/b^2) 1/EJ dx = [x - x^2/b + 1/3 x^3/b^2]_0^b 1/EJ$$

$$= (b - b + 1/3 b) 1/EJ = 1/3 b/EJ$$

$$L_{DG}^{xx} = \int_0^b (x^2/b^2) 1/EJ dx = [1/3 x^3/b^2]_0^b 1/EJ$$

$$= (1/3 b) 1/EJ = 1/3 b/EJ$$

$$L_{GA}^{xx} = \int_0^b (1/4 - 1/2 x/b + 1/4 x^2/b^2) 1/EJ dx = [1/4 x - 1/4 x^2/b + 1/12 x^3/b^2]_0^b 1/EJ$$

$$= (1/4 b - 1/4 b + 1/12 b) 1/EJ = 1/12 b/EJ$$

$$L_{AG}^{xx} = \int_0^b (1/4 x^2/b^2) 1/EJ dx = [1/12 x^3/b^2]_0^b 1/EJ$$

$$= (1/12 b) 1/EJ = 1/12 b/EJ$$

$$L_{FG}^{xo} = \int_0^b (3/4 x^2/b^2 - 1/4 x^3/b^3) Fb 1/EJ dx + \int_0^b (1/2 x/b) \theta dx$$

$$= [1/4 x^3/b^2 - 1/16 x^4/b^3]_0^b Fb 1/EJ + [1/4 x^2/b]_0^b \theta$$

$$= (1/4 b - 1/16 b) Fb 1/EJ + (1/4 b) \theta = 7/16 Fb^2/EJ$$

$$L_{GF}^{xo} = \int_0^b (1/2 - 3/4 x/b + 1/4 x^2/b^2) Fb 1/EJ dx + \int_0^b (-1/2 + 1/2 x/b) \theta dx$$

$$= [1/2 x - 3/8 x^2/b + 1/16 x^3/b^2]_0^b Fb 1/EJ + [-1/2 x + 1/4 x^2/b]_0^b \theta$$

$$= (1/2 b - 3/8 b + 1/16 b) Fb 1/EJ + (-1/2 b + 1/4 b) \theta = 7/16 Fb^2/EJ$$

$$L_{GD}^{xo} = \int_0^b (2 x/b - 2 x^2/b^2) Fb 1/EJ dx = [x^2/b - 2/3 x^3/b^2]_0^b Fb 1/EJ$$

$$= (b - 2/3 b) Fb 1/EJ = 1/3 Fb^2/EJ$$

$$L_{DG}^{xo} = \int_0^b (2 x/b - 2 x^2/b^2) Fb 1/EJ dx = [x^2/b - 2/3 x^3/b^2]_0^b Fb 1/EJ$$

$$= (b - 2/3 b) Fb 1/EJ = 1/3 Fb^2/EJ$$

$$L_{GA}^{xo} = \int_0^b (-1/2 + 3/4 x/b - 1/4 x^2/b^2) Fb 1/EJ dx = [-1/2 x + 3/8 x^2/b - 1/16 x^3/b^2]_0^b Fb 1/EJ$$

$$= (-1/2 b + 3/8 b - 1/16 b) Fb 1/EJ = -3/16 Fb^2/EJ$$

$$L_{AG}^{xo} = \int_0^b (-3/4 x^2/b^2 + 1/4 x^3/b^3) Fb 1/EJ dx = [-1/4 x^3/b^2 + 1/16 x^4/b^3]_0^b Fb 1/EJ$$

$$= (-1/4 b + 1/16 b) Fb 1/EJ = -3/16 Fb^2/EJ$$

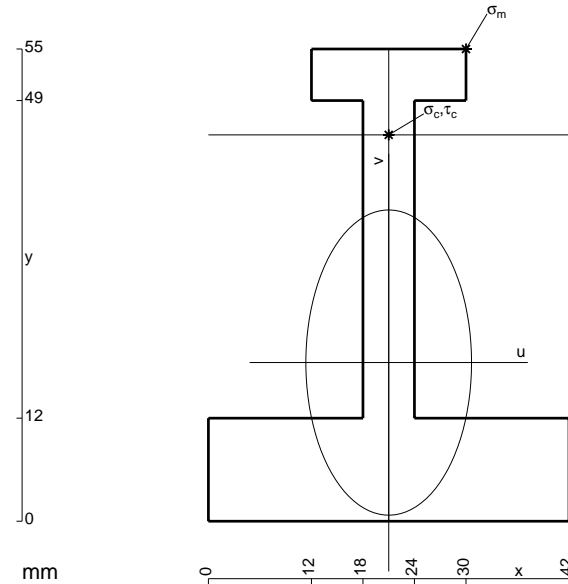

- A = 834. mm²
- J_u = 263619. mm⁴
- J_v = 77670. mm⁴
- y_g = 18.48 mm
- T_y = -2640. N
- M_x = -1504800. Nmm
- x_m = 30. mm
- y_m = 55. mm
- u_m = 9. mm
- v_m = 36.52 mm
- σ_m = -Mv/J_u = 208.5 N/mm²
- x_c = 21. mm
- y_c = 45. mm
- v_c = 26.52 mm
- σ_c = -Mv/J_u = 151.4 N/mm²
- τ_c = 7.185 N/mm²
- σ_o = √σ_c² + 3τ_c² = 151.9 N/mm²
- S = 4305. mm³

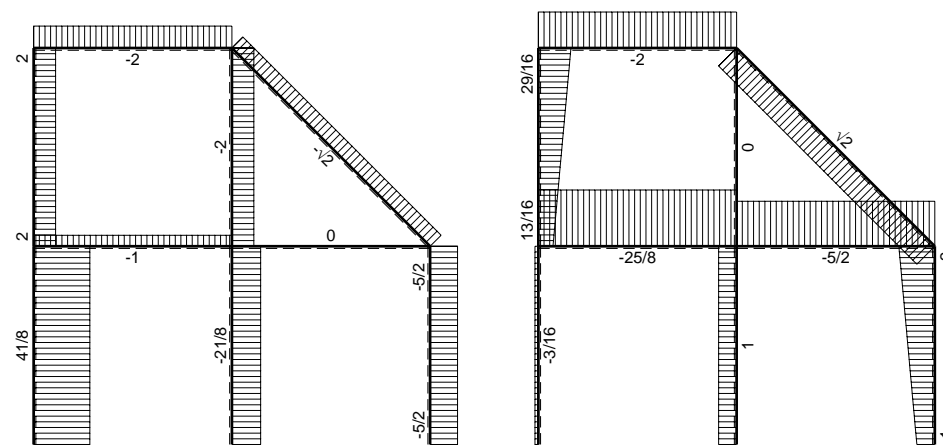
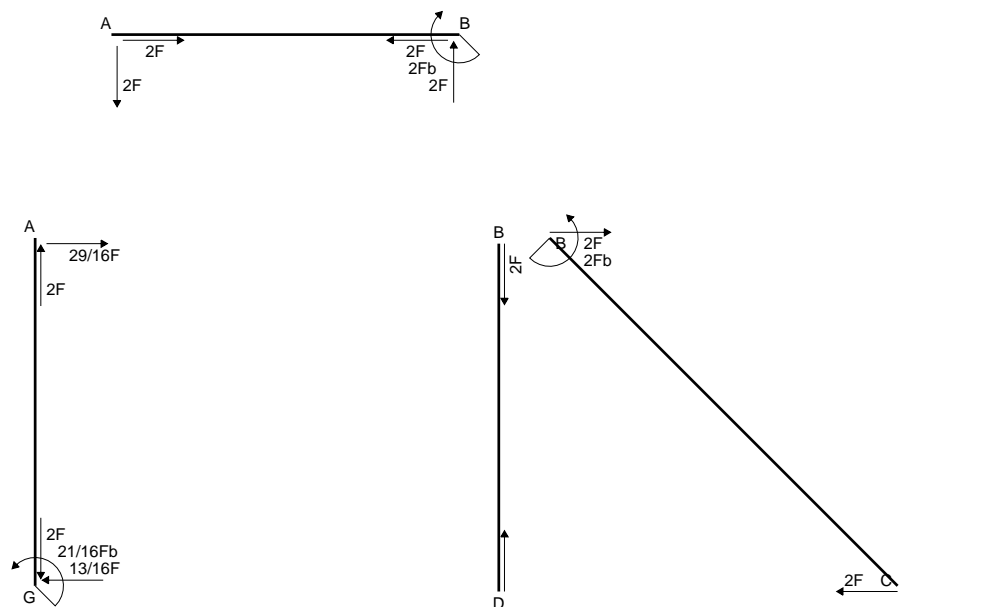

← ⊕ → F

↑ ⊕ ↓ F

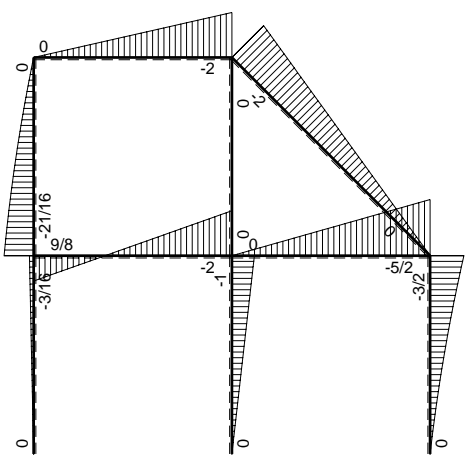
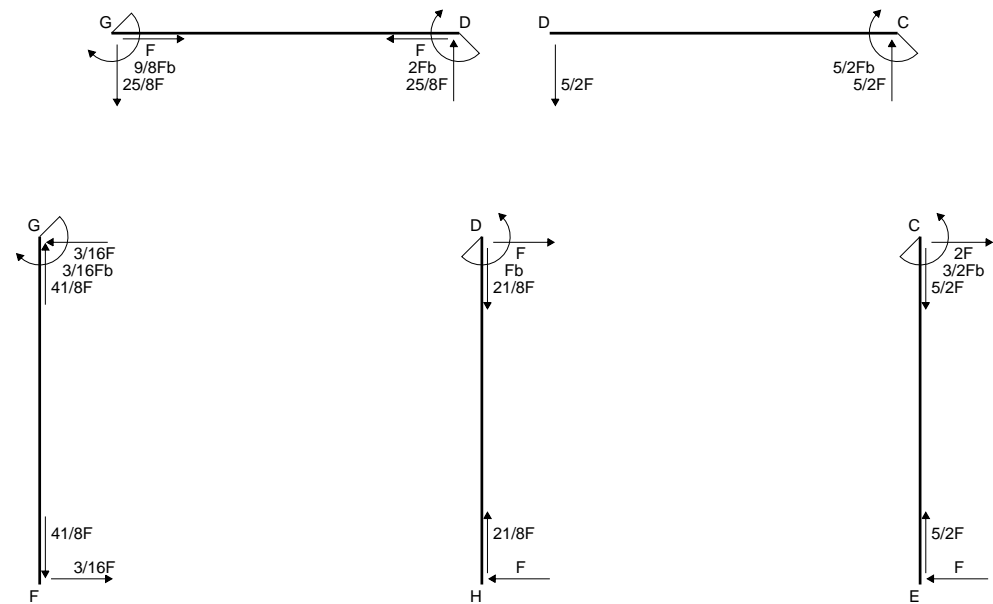

⊕ ⊖ Fb

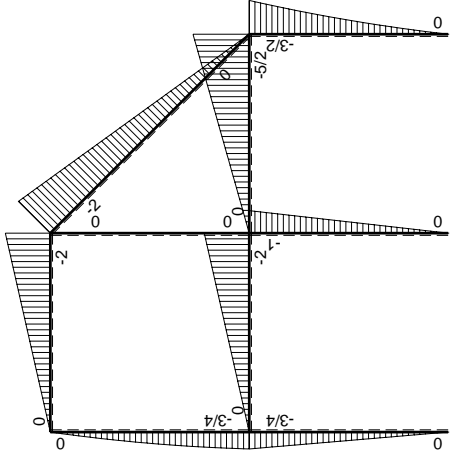
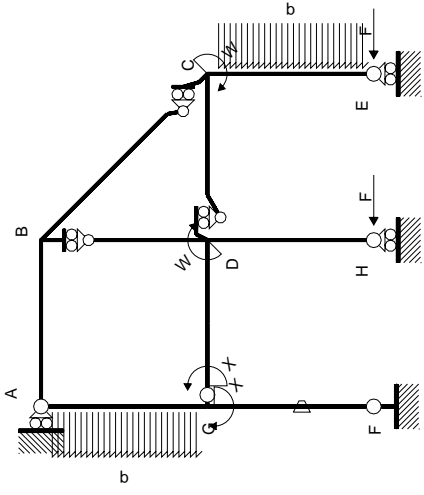

Schema di calcolo iperstatico

M_0 flessione da carichi assegnati

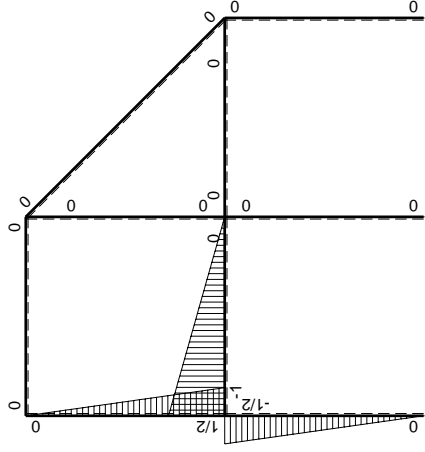

M_x flessione da iperstatica $X=1$

Quadro contributi PLV per iperstatica $X=W_{GD}$

→	$M_x(x)$	$M_o(x)$	θ	$M_x M_o$	$M_x \theta$	$M_x M_x$	$\int M_x(M_o/EJ+\theta)dx$	$\int X M_x M_x/EJdx$	
AB b	0	-2Fx	0	0	0	0	0+0	0	
BA b	0	2Fb-2Fx	0	0	0	0			
BC $\sqrt{2}b$	0	-2Fb+ $\sqrt{2}Fx$	0	0	0	0	0	0	
BD b	0	0	0	0	0	0	0+0	0	
DB b	0	0	0	0	0	0			
DC b	0	-5/2Fx	0	0	0	0	0+0	0	
CD b	0	5/2Fb-5/2Fx	0	0	0	0			
CE b	0	-3/2Fb+2Fx-1/2qx ²	0	0	0	0	0+0	0	
EC b	0	Fx+1/2qx ²	0	0	0	0			
FG b	-1/2x/b	-3/4Fx	-Fb/EJ	3/8Fx ² /b	1/2Fx/EJ	1/4x ² /b ²	(1/8+1/4)Fb ² /EJ	1/12Xb/EJ	
GF b	1/2-1/2x/b	3/4Fb-3/4Fx	Fb/EJ	3/8Fb-3/4Fx+3/8Fx ² /b	1/2Fb/EJ-1/2Fx/EJ	1/4-1/2x/b+1/4x ² /b ²			
GD b	-1+x/b	-2Fx	0	2Fx-2Fx ² /b	0	1-2x/b+x ² /b ²	(1/3+0)Fb ² /EJ	1/3Xb/EJ	
DG b	x/b	2Fb-2Fx	0	2Fx-2Fx ² /b	0	x ² /b ²			
DH b	0	-Fb+Fx	0	0	0	0	0+0	0	
HD b	0	Fx	0	0	0	0			
GA b	1/2-1/2x/b	-3/4Fb+1/4Fx+1/2qx ²	0	-3/8Fb+1/2Fx+1/8Fx ² /b-1/4qx ³ /b	0	1/4-1/2x/b+1/4x ² /b ²	(-7/48+0)Fb ² /EJ	1/12Xb/EJ	
AG b	-1/2x/b	5/4Fx-1/2qx ²	0	-5/8Fx ² /b+1/4qx ³ /b	0	1/4x ² /b ²			
	totali							9/16Fb ² /EJ	1/2Xb/EJ
	iperstatica $X=W_{GD}$							-9/8Fb	

Sviluppi di calcolo iperstatica

$$L_{FG}^{xx} = \int_0^b (1/4 x^2/b^2) 1/EJ dx = [1/12 x^3/b^2]_0^b 1/EJ$$

$$= (1/12 b) 1/EJ = 1/12 b/EJ$$

$$L_{GF}^{xx} = \int_0^b (1/4 - 1/2 x/b + 1/4 x^2/b^2) 1/EJ dx = [1/4 x - 1/4 x^2/b + 1/12 x^3/b^2]_0^b 1/EJ$$

$$= (1/4 b - 1/4 b + 1/12 b) 1/EJ = 1/12 b/EJ$$

$$L_{GD}^{xx} = \int_0^b (1 - 2 x/b + x^2/b^2) 1/EJ dx = [x - x^2/b + 1/3 x^3/b^2]_0^b 1/EJ$$

$$= (b - b + 1/3 b) 1/EJ = 1/3 b/EJ$$

$$L_{DG}^{xx} = \int_0^b (x^2/b^2) 1/EJ dx = [1/3 x^3/b^2]_0^b 1/EJ$$

$$= (1/3 b) 1/EJ = 1/3 b/EJ$$

$$L_{GA}^{xx} = \int_0^b (1/4 - 1/2 x/b + 1/4 x^2/b^2) 1/EJ dx = [1/4 x - 1/4 x^2/b + 1/12 x^3/b^2]_0^b 1/EJ$$

$$= (1/4 b - 1/4 b + 1/12 b) 1/EJ = 1/12 b/EJ$$

$$L_{AG}^{xx} = \int_0^b (1/4 x^2/b^2) 1/EJ dx = [1/12 x^3/b^2]_0^b 1/EJ$$

$$= (1/12 b) 1/EJ = 1/12 b/EJ$$

$$L_{FG}^{xo} = \int_0^b (3/8 x^2/b^2) Fb 1/EJ dx + \int_0^b (1/2 x/b) \theta dx = [1/8 x^3/b^2]_0^b Fb 1/EJ + [1/4 x^2/b]_0^b \theta$$

$$= (1/8 b) Fb 1/EJ + (1/4 b) \theta = 3/8 Fb^2/EJ$$

$$L_{GF}^{xo} = \int_0^b (3/8 - 3/4 x/b + 3/8 x^2/b^2) Fb 1/EJ dx + \int_0^b (-1/2 + 1/2 x/b) \theta dx$$

$$= [3/8 x - 3/8 x^2/b + 1/8 x^3/b^2]_0^b Fb 1/EJ + [-1/2 x + 1/4 x^2/b]_0^b \theta$$

$$= (3/8 b - 3/8 b + 1/8 b) Fb 1/EJ + (-1/2 b + 1/4 b) \theta = 3/8 Fb^2/EJ$$

$$L_{GD}^{xo} = \int_0^b (2 x/b - 2 x^2/b^2) Fb 1/EJ dx = [x^2/b - 2/3 x^3/b^2]_0^b Fb 1/EJ$$

$$= (b - 2/3 b) Fb 1/EJ = 1/3 Fb^2/EJ$$

$$L_{DG}^{xo} = \int_0^b (2 x/b - 2 x^2/b^2) Fb 1/EJ dx = [x^2/b - 2/3 x^3/b^2]_0^b Fb 1/EJ$$

$$= (b - 2/3 b) Fb 1/EJ = 1/3 Fb^2/EJ$$

$$L_{GA}^{xo} = \int_0^b (-3/8 + 1/2 x/b + 1/8 x^2/b^2 - 1/4 x^3/b^3) Fb 1/EJ dx$$

$$= [-3/8 x + 1/4 x^2/b + 1/24 x^3/b^2 - 1/16 x^4/b^3]_0^b Fb 1/EJ$$

$$= (-3/8 b + 1/4 b + 1/24 b - 1/16 b) Fb 1/EJ = -7/48 Fb^2/EJ$$

$$L_{AG}^{xo} = \int_0^b (-5/8 x^2/b^2 + 1/4 x^3/b^3) Fb 1/EJ dx = [-5/24 x^3/b^2 + 1/16 x^4/b^3]_0^b Fb 1/EJ$$

$$= (-5/24 b + 1/16 b) Fb 1/EJ = -7/48 Fb^2/EJ$$

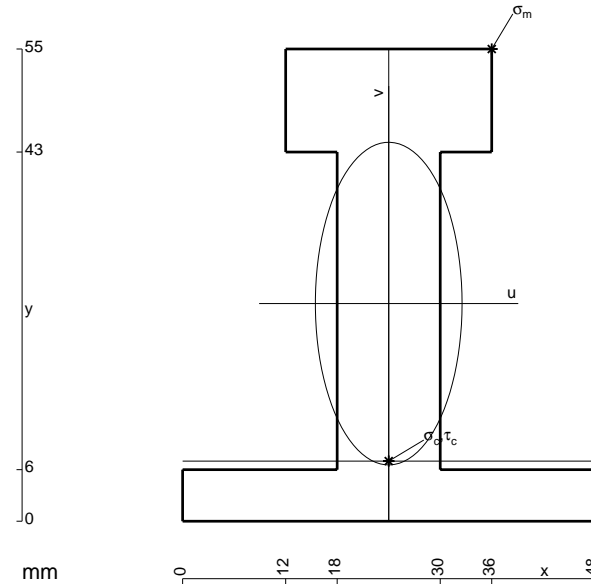

$$A = 1020. \text{ mm}^2$$

$$J_u = 360241. \text{ mm}^4$$

$$J_v = 74448. \text{ mm}^4$$

$$y_g = 25.35 \text{ mm}$$

$$T_y = -4300. \text{ N}$$

$$M_x = -2666000. \text{ Nmm}$$

$$x_m = 36. \text{ mm}$$

$$y_m = 55. \text{ mm}$$

$$u_m = 12. \text{ mm}$$

$$v_m = 29.65 \text{ mm}$$

$$\sigma_m = -Mv/J_u = 219.4 \text{ N/mm}^2$$

$$x_c = 24. \text{ mm}$$

$$y_c = 7. \text{ mm}$$

$$v_c = -18.35 \text{ mm}$$

$$\sigma_c = -Mv/J_u = -135.8 \text{ N/mm}^2$$

$$\tau_c = 6.627 \text{ N/mm}^2$$

$$\sigma_\varphi = \sqrt{\sigma^2 + 3\tau^2} = 136.3 \text{ N/mm}^2$$

$$S = 6662. \text{ mm}^3$$

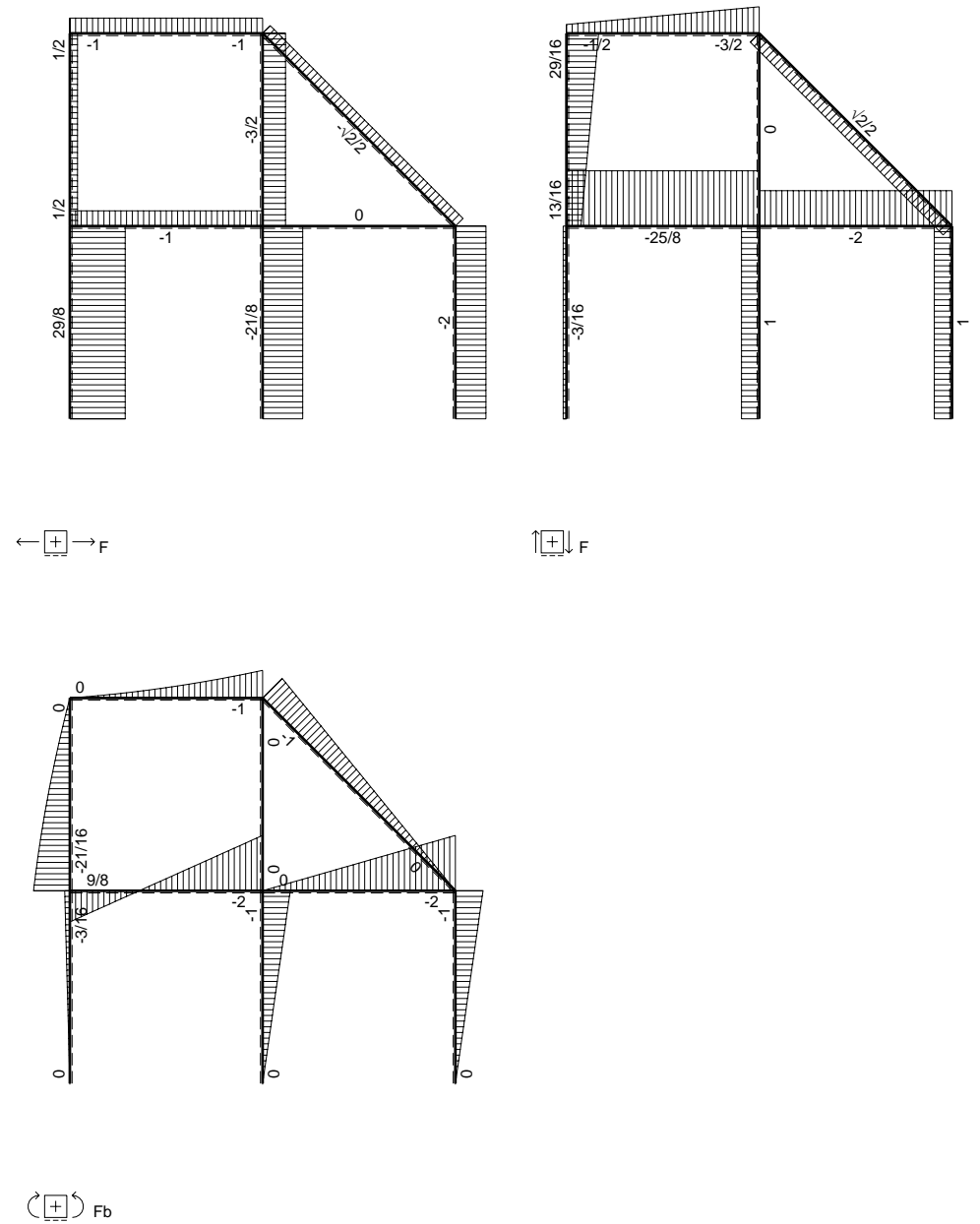
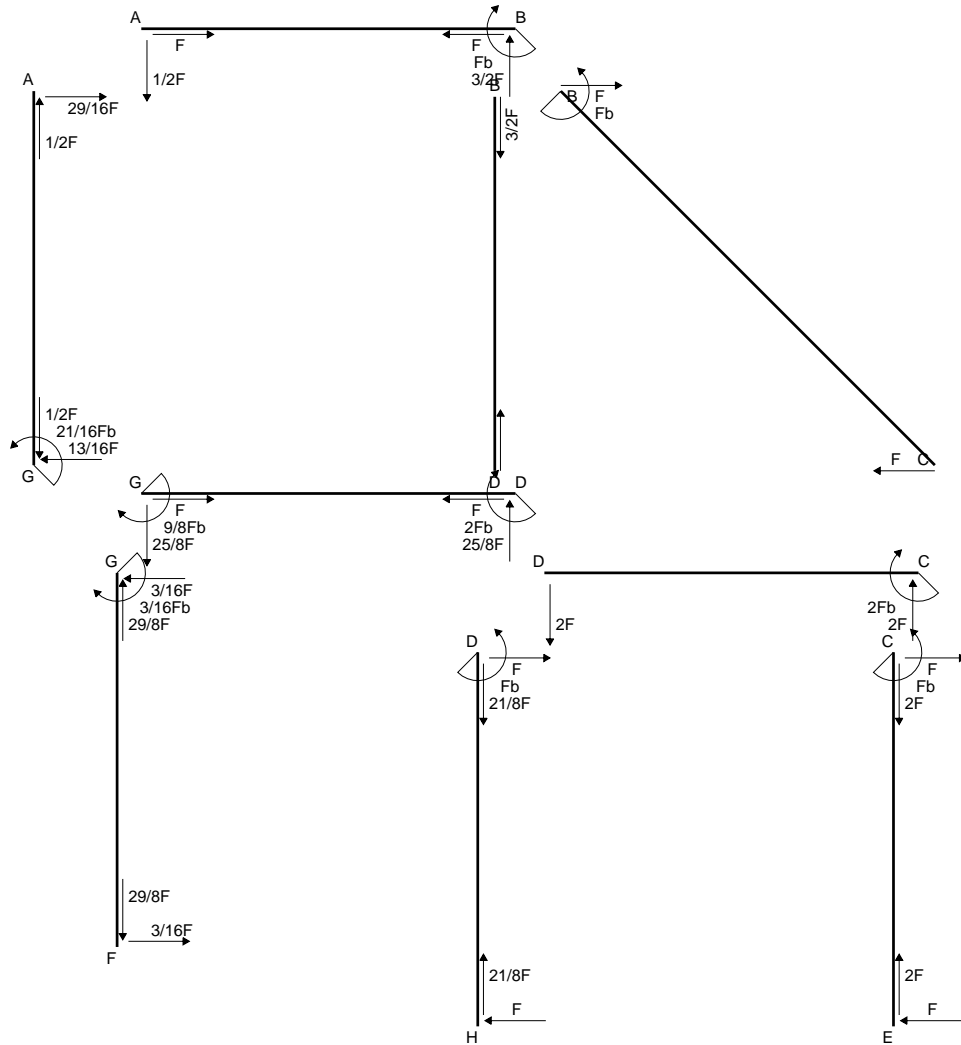

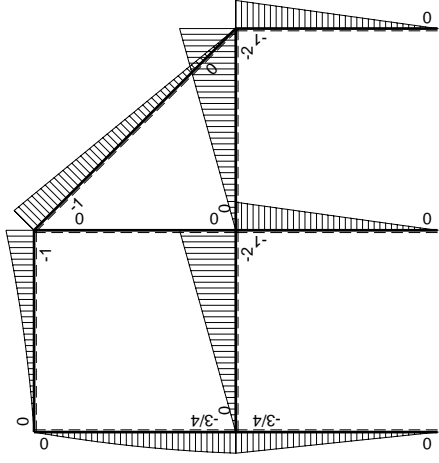
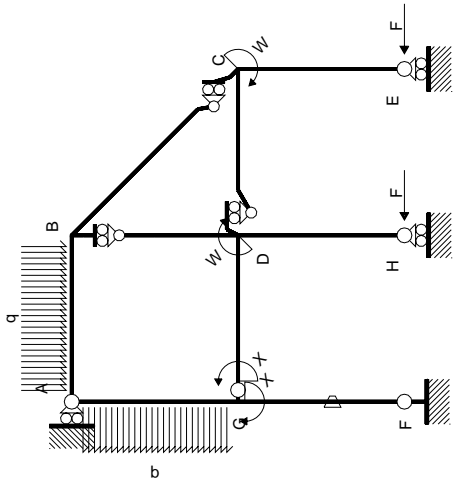

Schema di calcolo iperstatico

M_0 flessione da carichi assegnati

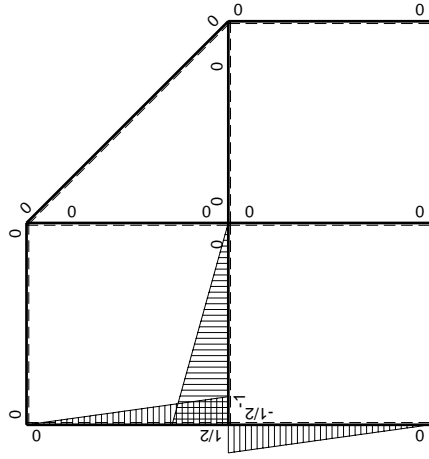

M_X flessione da iperstatica $X=1$

Quadro contributi PLV per iperstatica $X=W_{GD}$

→	$M_x(x)$	$M_o(x)$	θ	$M_x M_o$	$M_x \theta$	$M_x M_x$	$\int M_x(M_o/EJ+\theta)dx$	$\int X M_x M_x/EJ dx$	
AB b	0	$-1/2Fx-1/2qx^2$	0	0	0	0	0+0	0	
BA b	0	$Fb-3/2Fx+1/2qx^2$	0	0	0	0	0	0	
BC $\sqrt{2}b$	0	$-Fb+\sqrt{2}/2Fx$	0	0	0	0	0	0	
BD b	0	0	0	0	0	0	0+0	0	
DB b	0	0	0	0	0	0	0	0	
DC b	0	$-2Fx$	0	0	0	0	0+0	0	
CD b	0	$2Fb-2Fx$	0	0	0	0	0	0	
CE b	0	$-Fb+Fx$	0	0	0	0	0+0	0	
EC b	0	Fx	0	0	0	0	0	0	
FG b	$-1/2x/b$	$-3/4Fx$	$-Fb/EJ$	$3/8Fx^2/b$	$1/2Fx/EJ$	$1/4x^2/b^2$	$(1/8+1/4)Fb^2/EJ$	$1/12Xb/EJ$	
GF b	$1/2-1/2x/b$	$3/4Fb-3/4Fx$	Fb/EJ	$3/8Fb-3/4Fx+3/8Fx^2/b$	$1/2Fb/EJ-1/2Fx/EJ$	$1/4-1/2x/b+1/4x^2/b^2$			
GD b	$-1+x/b$	$-2Fx$	0	$2Fx-2Fx^2/b$	0	$1-2x/b+x^2/b^2$	$(1/3+0)Fb^2/EJ$	$1/3Xb/EJ$	
DG b	x/b	$2Fb-2Fx$	0	$2Fx-2Fx^2/b$	0	x^2/b^2			
DH b	0	$-Fb+Fx$	0	0	0	0	0+0	0	
HD b	0	Fx	0	0	0	0	0	0	
GA b	$1/2-1/2x/b$	$-3/4Fb+1/4Fx+1/2qx^2$	0	$-3/8Fb+1/2Fx+1/8Fx^2/b-1/4qx^3/b$	0	$1/4-1/2x/b+1/4x^2/b^2$	$(-7/48+0)Fb^2/EJ$	$1/12Xb/EJ$	
AG b	$-1/2x/b$	$5/4Fx-1/2qx^2$	0	$-5/8Fx^2/b+1/4qx^3/b$	0	$1/4x^2/b^2$			
	totali							$9/16Fb^2/EJ$	$1/2Xb/EJ$
	iperstatica $X=W_{GD}$							$-9/8Fb$	

Sviluppi di calcolo iperstatica

$$L_{FG}^{xx} = \int_0^b (1/4 x^2/b^2) 1/EJ dx = [1/12 x^3/b^2]_0^b 1/EJ$$

$$= (1/12 b) 1/EJ = 1/12 b/EJ$$

$$L_{GF}^{xx} = \int_0^b (1/4 -1/2 x/b +1/4 x^2/b^2) 1/EJ dx = [1/4 x -1/4 x^2/b +1/12 x^3/b^2]_0^b 1/EJ$$

$$= (1/4 b -1/4 b +1/12 b) 1/EJ = 1/12 b/EJ$$

$$L_{GD}^{xx} = \int_0^b (1 -2 x/b + x^2/b^2) 1/EJ dx = [x - x^2/b +1/3 x^3/b^2]_0^b 1/EJ$$

$$= (b - b +1/3 b) 1/EJ = 1/3 b/EJ$$

$$L_{DG}^{xx} = \int_0^b (x^2/b^2) 1/EJ dx = [1/3 x^3/b^2]_0^b 1/EJ$$

$$= (1/3 b) 1/EJ = 1/3 b/EJ$$

$$L_{GA}^{xx} = \int_0^b (1/4 -1/2 x/b +1/4 x^2/b^2) 1/EJ dx = [1/4 x -1/4 x^2/b +1/12 x^3/b^2]_0^b 1/EJ$$

$$= (1/4 b -1/4 b +1/12 b) 1/EJ = 1/12 b/EJ$$

$$L_{AG}^{xx} = \int_0^b (1/4 x^2/b^2) 1/EJ dx = [1/12 x^3/b^2]_0^b 1/EJ$$

$$= (1/12 b) 1/EJ = 1/12 b/EJ$$

$$L_{FG}^{xo} = \int_0^b (3/8 x^2/b^2) Fb 1/EJ dx + \int_0^b (1/2 x/b) \theta dx = [1/8 x^3/b^2]_0^b Fb 1/EJ + [1/4 x^2/b]_0^b \theta$$

$$= (1/8 b) Fb 1/EJ + (1/4 b) \theta = 3/8 Fb^2/EJ$$

$$L_{GF}^{xo} = \int_0^b (3/8 -3/4 x/b +3/8 x^2/b^2) Fb 1/EJ dx + \int_0^b (-1/2 +1/2 x/b) \theta dx$$

$$= [3/8 x -3/8 x^2/b +1/8 x^3/b^2]_0^b Fb 1/EJ + [-1/2 x +1/4 x^2/b]_0^b \theta$$

$$= (3/8 b -3/8 b +1/8 b) Fb 1/EJ + (-1/2 b +1/4 b) \theta = 3/8 Fb^2/EJ$$

$$L_{GD}^{xo} = \int_0^b (2 x/b -2 x^2/b^2) Fb 1/EJ dx = [x^2/b -2/3 x^3/b^2]_0^b Fb 1/EJ$$

$$= (b -2/3 b) Fb 1/EJ = 1/3 Fb^2/EJ$$

$$L_{DG}^{xo} = \int_0^b (2 x/b -2 x^2/b^2) Fb 1/EJ dx = [x^2/b -2/3 x^3/b^2]_0^b Fb 1/EJ$$

$$= (b -2/3 b) Fb 1/EJ = 1/3 Fb^2/EJ$$

$$L_{GA}^{xo} = \int_0^b (-3/8 +1/2 x/b +1/8 x^2/b^2 -1/4 x^3/b^3) Fb 1/EJ dx$$

$$= [-3/8 x +1/4 x^2/b +1/24 x^3/b^2 -1/16 x^4/b^3]_0^b Fb 1/EJ$$

$$= (-3/8 b +1/4 b +1/24 b -1/16 b) Fb 1/EJ = -7/48 Fb^2/EJ$$

$$L_{AG}^{xo} = \int_0^b (-5/8 x^2/b^2 +1/4 x^3/b^3) Fb 1/EJ dx = [-5/24 x^3/b^2 +1/16 x^4/b^3]_0^b Fb 1/EJ$$

$$= (-5/24 b +1/16 b) Fb 1/EJ = -7/48 Fb^2/EJ$$

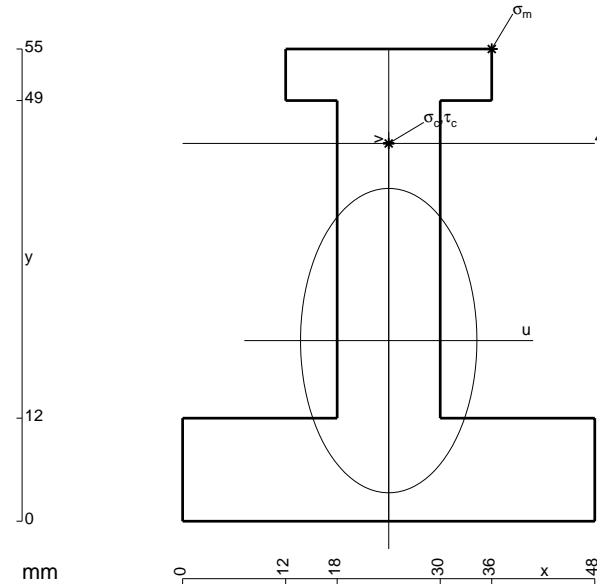

- A = 1164. mm²
- J_u = 366050. mm⁴
- J_v = 122832. mm⁴
- y_g = 21.04 mm
- T_y = -3680. N
- M_x = -2465600. Nmm
- x_m = 36. mm
- y_m = 55. mm
- u_m = 12. mm
- v_m = 33.96 mm
- σ_m = -Mv/J_u = 228.8 N/mm²
- x_c = 24. mm
- y_c = 44. mm
- v_c = 22.96 mm
- σ_c = -Mv/J_u = 154.7 N/mm²
- τ_c = 5.015 N/mm²
- σ_o = √σ²+3τ² = 154.9 N/mm²
- S = 5987. mm³

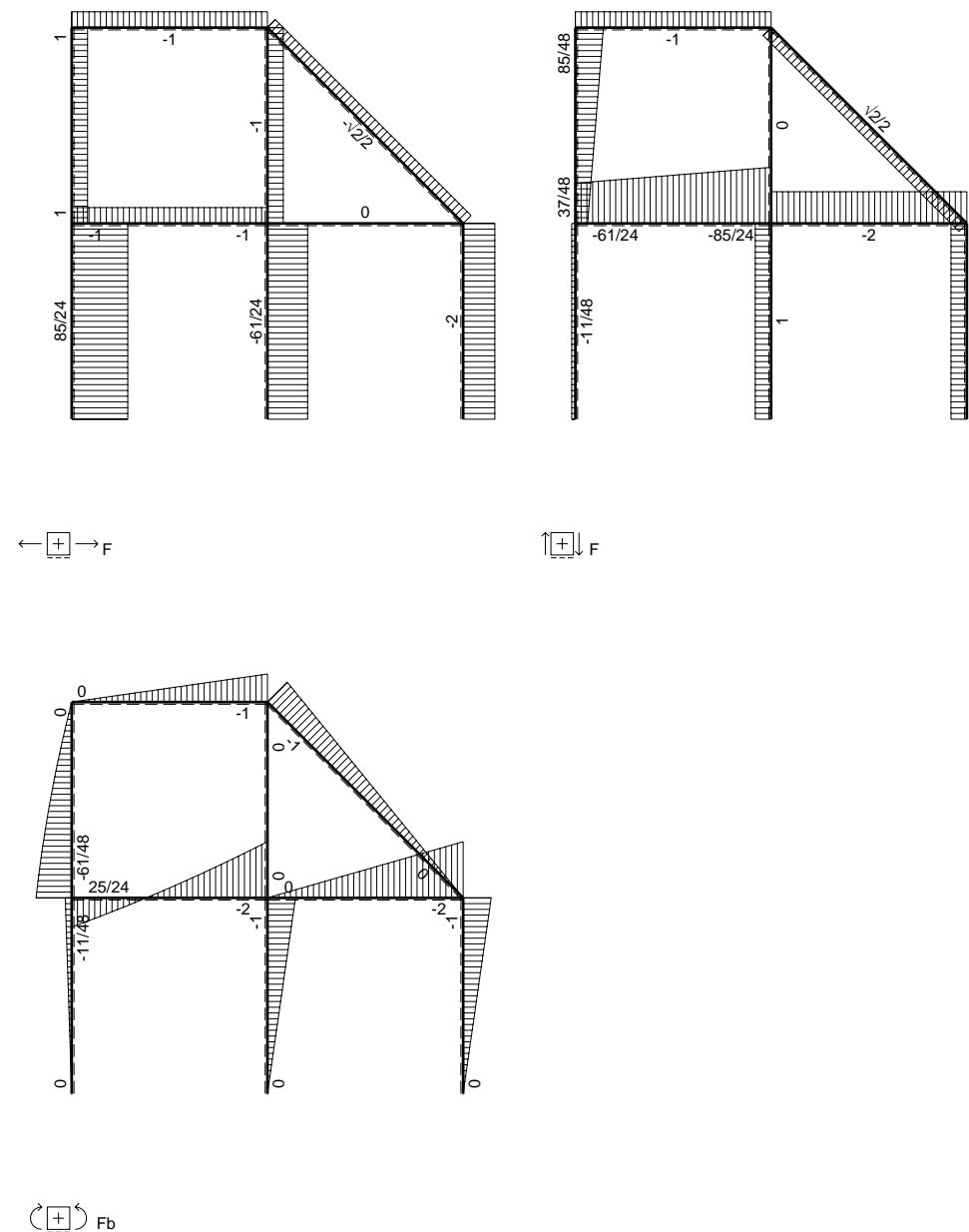
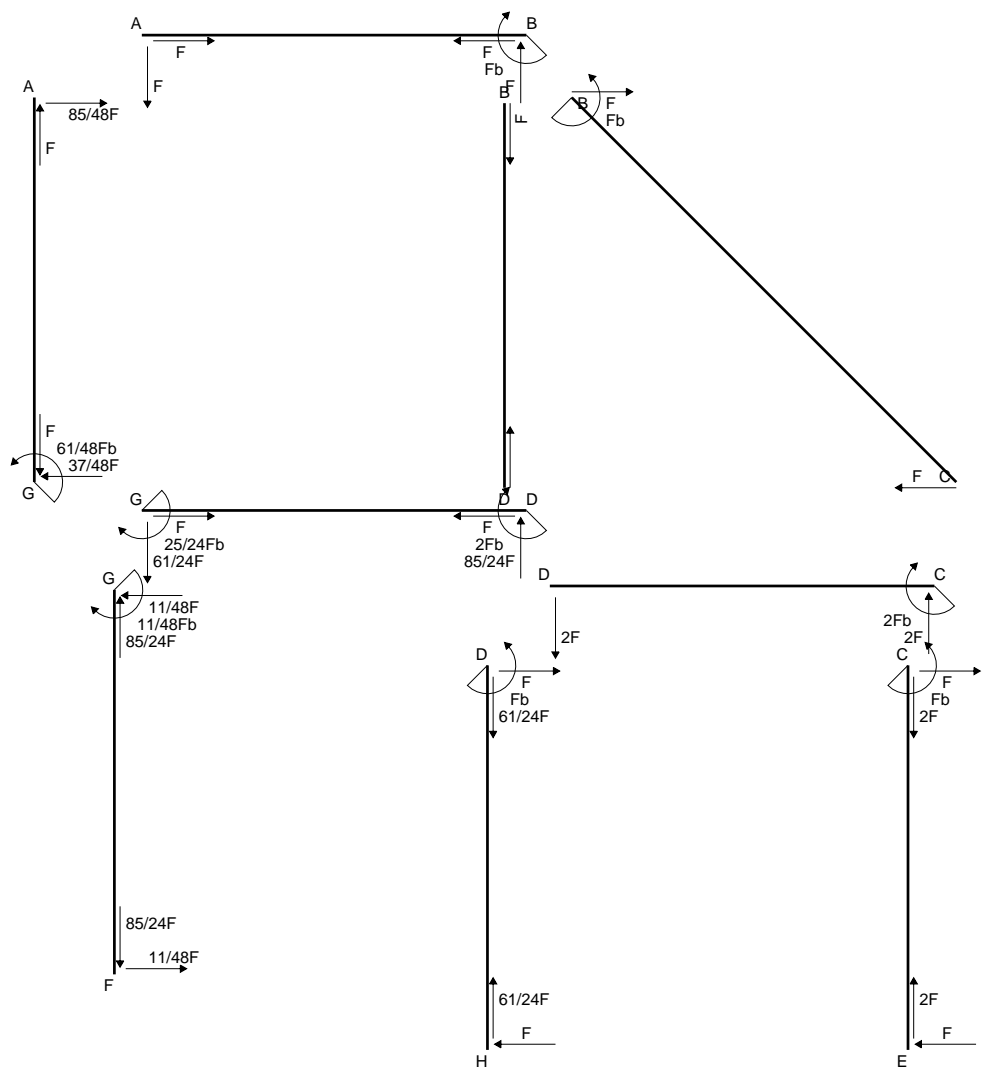

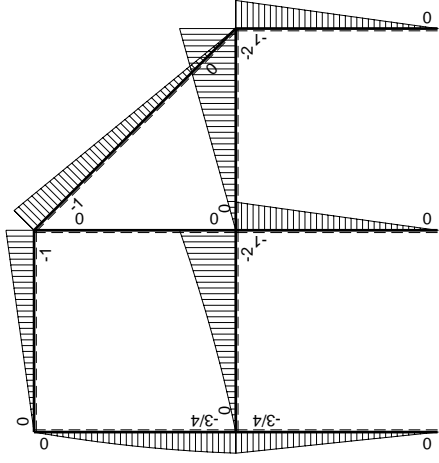
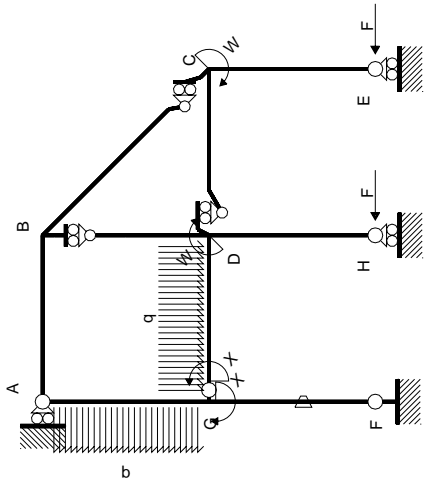

Schema di calcolo iperstatico

M_0 flessione da carichi assegnati

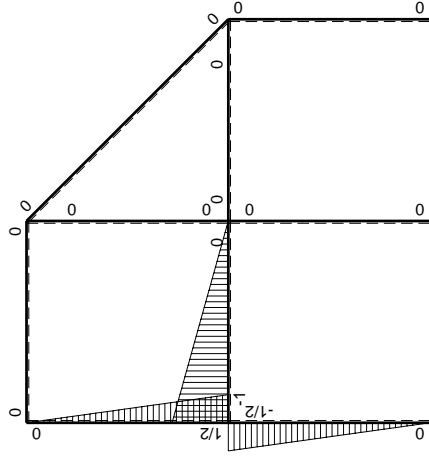

M_x flessione da iperstatica $X=1$

Quadro contributi PLV per iperstatica $X=W_{GD}$

→	$M_x(x)$	$M_o(x)$	θ	$M_x M_o$	$M_x \theta$	$M_x M_x$	$\int M_x(M_o/EJ+\theta)dx$	$\int X M_x M_x/EJ dx$
AB b	0	-Fx	0	0	0	0	0+0	0
BA b	0	Fb-Fx	0	0	0	0	0	0
BC $\sqrt{2}b$	0	-Fb+ $\sqrt{2}/2Fx$	0	0	0	0	0	0
BD b	0	0	0	0	0	0	0+0	0
DB b	0	0	0	0	0	0	0	0
DC b	0	-2Fx	0	0	0	0	0+0	0
CD b	0	2Fb-2Fx	0	0	0	0	0	0
CE b	0	-Fb+Fx	0	0	0	0	0+0	0
EC b	0	Fx	0	0	0	0	0	0
FG b	-1/2x/b	-3/4Fx	-Fb/EJ	$3/8Fx^2/b$	$1/2Fx/EJ$	$1/4x^2/b^2$	$(1/8+1/4)Fb^2/EJ$	$1/12Xb/EJ$
GF b	$1/2-1/2x/b$	$3/4Fb-3/4Fx$	Fb/EJ	$3/8Fb-3/4Fx+3/8Fx^2/b$	$1/2Fb/EJ-1/2Fx/EJ$	$1/4-1/2x/b+1/4x^2/b^2$	$(7/24+0)Fb^2/EJ$	$1/3Xb/EJ$
GD b	-1+x/b	$-3/2Fx-1/2qx^2$	0	$3/2Fx-Fx^2/b-1/2qx^3/b$	0	$1-2x/b+x^2/b^2$	$(7/24+0)Fb^2/EJ$	$1/3Xb/EJ$
DG b	x/b	$2Fb-5/2Fx+1/2qx^2$	0	$2Fx-5/2Fx^2/b+1/2qx^3/b$	0	x^2/b^2	0	0
DH b	0	-Fb+Fx	0	0	0	0	0+0	0
HD b	0	Fx	0	0	0	0	0	0
GA b	$1/2-1/2x/b$	$-3/4Fb+1/4Fx+1/2qx^2$	0	$-3/8Fb+1/2Fx+1/8Fx^2/b-1/4qx^3/b$	0	$1/4-1/2x/b+1/4x^2/b^2$	$(-7/48+0)Fb^2/EJ$	$1/12Xb/EJ$
AG b	-1/2x/b	$5/4Fx-1/2qx^2$	0	$-5/8Fx^2/b+1/4qx^3/b$	0	$1/4x^2/b^2$	0	0
	totali						$25/48Fb^2/EJ$	$1/2Xb/EJ$
	iperstatica $X=W_{GD}$						-25/24Fb	

Sviluppi di calcolo iperstatica

$$L_{FG}^{xx} = \int_0^b (1/4 x^2/b^2) 1/EJ dx = [1/12 x^3/b^2]_0^b 1/EJ$$

$$= (1/12 b) 1/EJ = 1/12 b/EJ$$

$$L_{GF}^{xx} = \int_0^b (1/4 - 1/2 x/b + 1/4 x^2/b^2) 1/EJ dx = [1/4 x - 1/4 x^2/b + 1/12 x^3/b^2]_0^b 1/EJ$$

$$= (1/4 b - 1/4 b + 1/12 b) 1/EJ = 1/12 b/EJ$$

$$L_{GD}^{xx} = \int_0^b (1 - 2 x/b + x^2/b^2) 1/EJ dx = [x - x^2/b + 1/3 x^3/b^2]_0^b 1/EJ$$

$$= (b - b + 1/3 b) 1/EJ = 1/3 b/EJ$$

$$L_{DG}^{xx} = \int_0^b (x^2/b^2) 1/EJ dx = [1/3 x^3/b^2]_0^b 1/EJ$$

$$= (1/3 b) 1/EJ = 1/3 b/EJ$$

$$L_{GA}^{xx} = \int_0^b (1/4 - 1/2 x/b + 1/4 x^2/b^2) 1/EJ dx = [1/4 x - 1/4 x^2/b + 1/12 x^3/b^2]_0^b 1/EJ$$

$$= (1/4 b - 1/4 b + 1/12 b) 1/EJ = 1/12 b/EJ$$

$$L_{AG}^{xx} = \int_0^b (1/4 x^2/b^2) 1/EJ dx = [1/12 x^3/b^2]_0^b 1/EJ$$

$$= (1/12 b) 1/EJ = 1/12 b/EJ$$

$$L_{FG}^{xo} = \int_0^b (3/8 x^2/b^2) Fb 1/EJ dx + \int_0^b (1/2 x/b) \theta dx = [1/8 x^3/b^2]_0^b Fb 1/EJ + [1/4 x^2/b]_0^b \theta$$

$$= (1/8 b) Fb 1/EJ + (1/4 b) \theta = 3/8 Fb^2/EJ$$

$$L_{GF}^{xo} = \int_0^b (3/8 - 3/4 x/b + 3/8 x^2/b^2) Fb 1/EJ dx + \int_0^b (-1/2 + 1/2 x/b) \theta dx$$

$$= [3/8 x - 3/8 x^2/b + 1/8 x^3/b^2]_0^b Fb 1/EJ + [-1/2 x + 1/4 x^2/b]_0^b \theta$$

$$= (3/8 b - 3/8 b + 1/8 b) Fb 1/EJ + (-1/2 b + 1/4 b) \theta = 3/8 Fb^2/EJ$$

$$L_{GD}^{xo} = \int_0^b (3/2 x/b - x^2/b^2 - 1/2 x^3/b^3) Fb 1/EJ dx = [3/4 x^2/b - 1/3 x^3/b^2 - 1/8 x^4/b^3]_0^b Fb 1/EJ$$

$$= (3/4 b - 1/3 b - 1/8 b) Fb 1/EJ = 7/24 Fb^2/EJ$$

$$L_{DG}^{xo} = \int_0^b (2 x/b - 5/2 x^2/b^2 + 1/2 x^3/b^3) Fb 1/EJ dx = [x^2/b - 5/6 x^3/b^2 + 1/8 x^4/b^3]_0^b Fb 1/EJ$$

$$= (b - 5/6 b + 1/8 b) Fb 1/EJ = 7/24 Fb^2/EJ$$

$$L_{GA}^{xo} = \int_0^b (-3/8 + 1/2 x/b + 1/8 x^2/b^2 - 1/4 x^3/b^3) Fb 1/EJ dx$$

$$= [-3/8 x + 1/4 x^2/b + 1/24 x^3/b^2 - 1/16 x^4/b^3]_0^b Fb 1/EJ$$

$$= (-3/8 b + 1/4 b + 1/24 b - 1/16 b) Fb 1/EJ = -7/48 Fb^2/EJ$$

$$L_{AG}^{xo} = \int_0^b (-5/8 x^2/b^2 + 1/4 x^3/b^3) Fb 1/EJ dx = [-5/24 x^3/b^2 + 1/16 x^4/b^3]_0^b Fb 1/EJ$$

$$= (-5/24 b + 1/16 b) Fb 1/EJ = -7/48 Fb^2/EJ$$

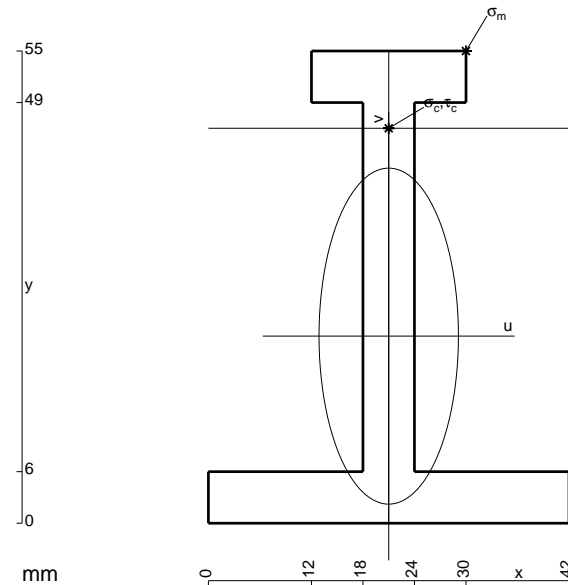

$$A = 618. \text{ mm}^2$$

$$J_u = 236783. \text{ mm}^4$$

$$J_v = 40734. \text{ mm}^4$$

$$y_g = 21.79 \text{ mm}$$

$$T_y = -2360. \text{ N}$$

$$M_x = -1699200. \text{ Nmm}$$

$$x_m = 30. \text{ mm}$$

$$y_m = 55. \text{ mm}$$

$$u_m = 9. \text{ mm}$$

$$v_m = 33.21 \text{ mm}$$

$$\sigma_m = -Mv/J_u = 238.3 \text{ N/mm}^2$$

$$x_c = 21. \text{ mm}$$

$$y_c = 46. \text{ mm}$$

$$v_c = 24.21 \text{ mm}$$

$$\sigma_c = -Mv/J_u = 173.7 \text{ N/mm}^2$$

$$\tau_c = 6.188 \text{ N/mm}^2$$

$$\sigma_{\varphi} = \sqrt{\sigma^2 + 3\tau^2} = 174.1 \text{ N/mm}^2$$

$$S = 3725. \text{ mm}^3$$

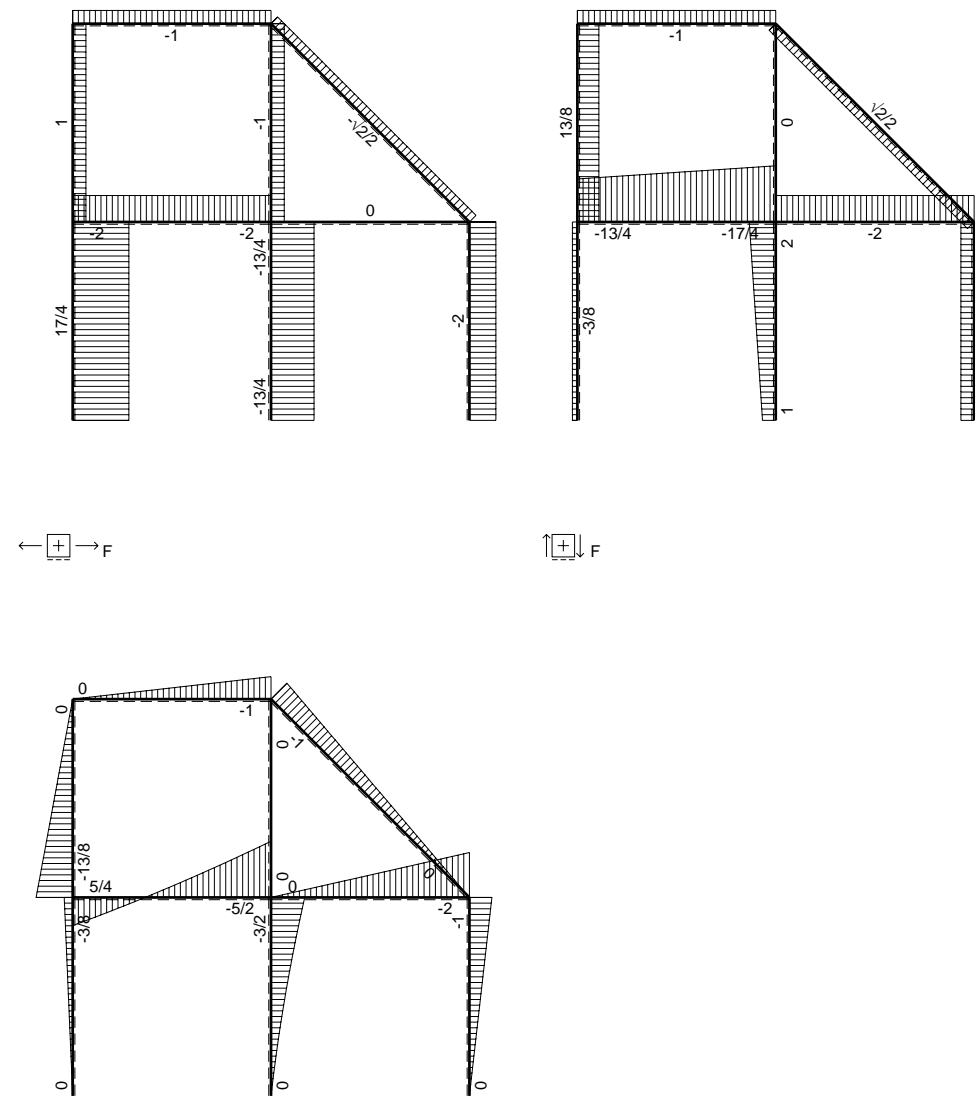
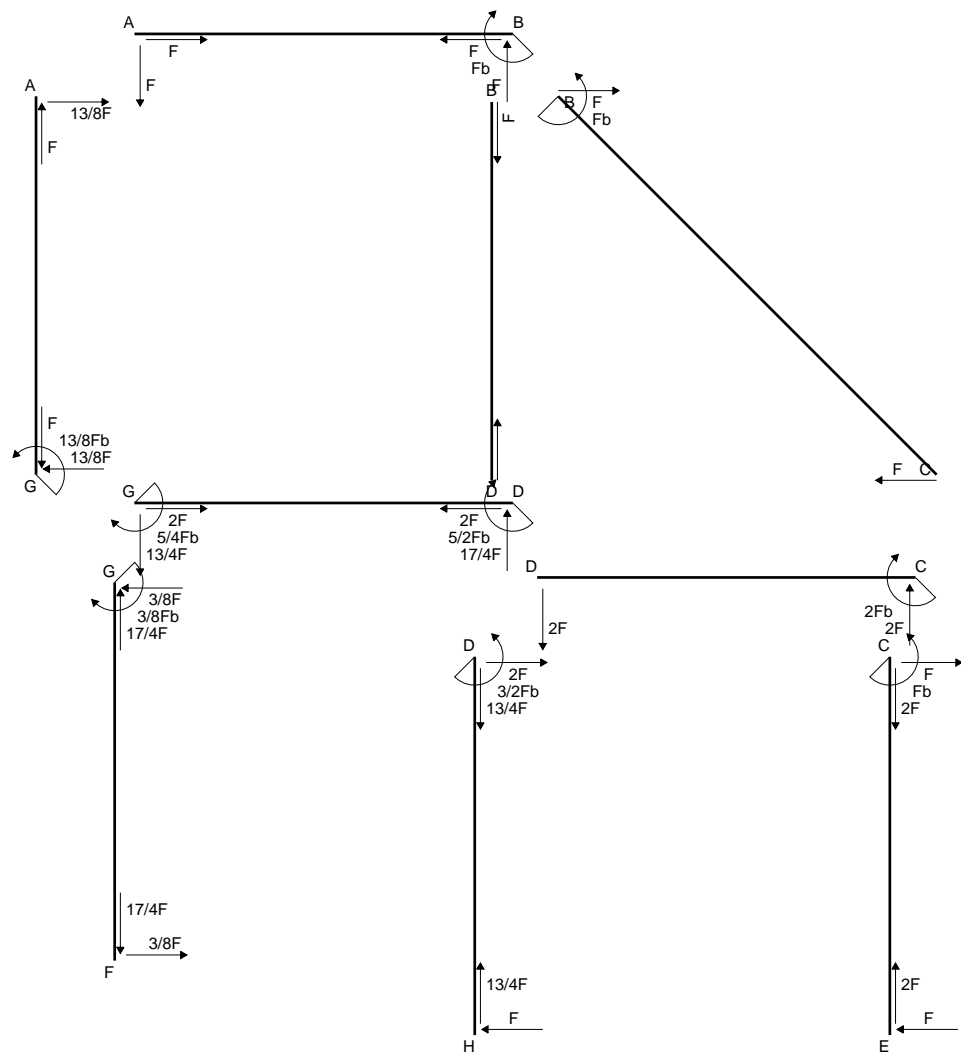

$\curvearrowright (+) F_b$

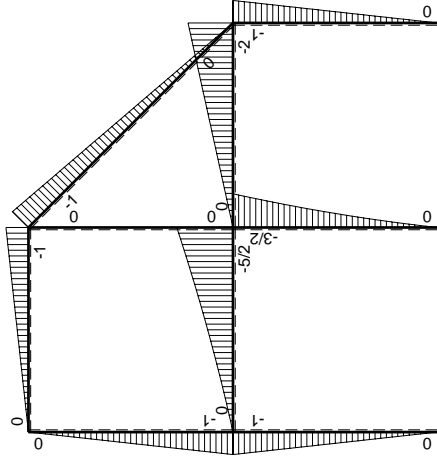
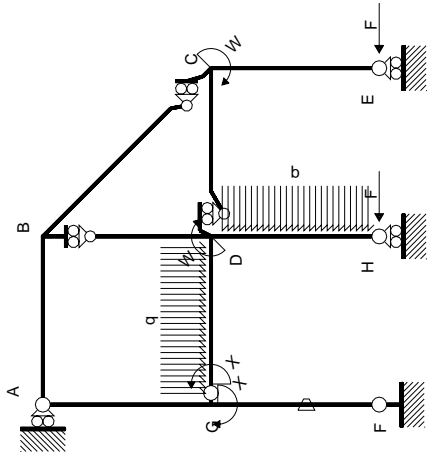

Schema di calcolo iperstatico

M_0 flessione da carichi assegnati

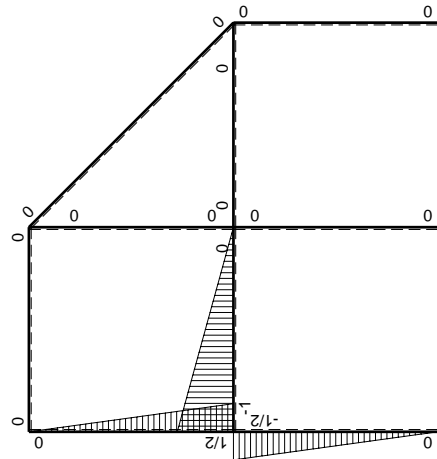

M_x flessione da iperstatica $X=1$

Quadro contributi PLV per iperstatica $X=W_{GD}$

→	$M_x(x)$	$M_o(x)$	θ	$M_x M_o$	$M_x \theta$	$M_x M_x$	$\int M_x(M_o/EJ+\theta)dx$	$\int X M_x M_x/EJdx$
AB b	0	-Fx	0	0	0	0	0+0	0
BA b	0	Fb-Fx	0	0	0	0	0	0
BC $\sqrt{2}b$	0	-Fb+ $\sqrt{2}/2Fx$	0	0	0	0	0	0
BD b	0	0	0	0	0	0	0+0	0
DB b	0	0	0	0	0	0	0	0
DC b	0	-2Fx	0	0	0	0	0+0	0
CD b	0	2Fb-2Fx	0	0	0	0	0	0
CE b	0	-Fb+Fx	0	0	0	0	0+0	0
EC b	0	Fx	0	0	0	0	0	0
FG b	-1/2x/b	-Fx	-Fb/EJ	1/2Fx ² /b	1/2Fx/EJ	1/4x ² /b ²	(1/6+1/4)Fb ² /EJ	1/12Xb/EJ
GF b	1/2-1/2x/b	Fb-Fx	Fb/EJ	1/2Fb-Fx+1/2Fx ² /b	1/2Fb/EJ-1/2Fx/EJ	1/4-1/2x/b+1/4x ² /b ²		
GD b	-1+x/b	-2Fx-1/2qx ²	0	2Fx-3/2Fx ² /b-1/2qx ³ /b	0	1-2x/b+x ² /b ²	(3/8+0)Fb ² /EJ	1/3Xb/EJ
DG b	x/b	5/2Fb-3Fx+1/2qx ²	0	5/2Fx-3Fx ² /b+1/2qx ³ /b	0	x ² /b ²		
DH b	0	-3/2Fb+2Fx-1/2qx ²	0	0	0	0	0+0	0
HD b	0	Fx+1/2qx ²	0	0	0	0		
GA b	1/2-1/2x/b	-Fb+Fx	0	-1/2Fb+Fx-1/2Fx ² /b	0	1/4-1/2x/b+1/4x ² /b ²	(-1/6+0)Fb ² /EJ	1/12Xb/EJ
AG b	-1/2x/b	Fx	0	-1/2Fx ² /b	0	1/4x ² /b ²		
	totali						5/8Fb ² /EJ	1/2Xb/EJ
	iperstatica $X=W_{GD}$						-5/4Fb	

Sviluppi di calcolo iperstatica

$$L_{FG}^{xx} = \int_0^b (1/4 x^2/b^2) 1/EJ dx = [1/12 x^3/b^2]_0^b 1/EJ$$

$$= (1/12 b) 1/EJ = 1/12 b/EJ$$

$$L_{GF}^{xx} = \int_0^b (1/4 - 1/2 x/b + 1/4 x^2/b^2) 1/EJ dx = [1/4 x - 1/4 x^2/b + 1/12 x^3/b^2]_0^b 1/EJ$$

$$= (1/4 b - 1/4 b + 1/12 b) 1/EJ = 1/12 b/EJ$$

$$L_{GD}^{xx} = \int_0^b (1 - 2 x/b + x^2/b^2) 1/EJ dx = [x - x^2/b + 1/3 x^3/b^2]_0^b 1/EJ$$

$$= (b - b + 1/3 b) 1/EJ = 1/3 b/EJ$$

$$L_{DG}^{xx} = \int_0^b (x^2/b^2) 1/EJ dx = [1/3 x^3/b^2]_0^b 1/EJ$$

$$= (1/3 b) 1/EJ = 1/3 b/EJ$$

$$L_{GA}^{xx} = \int_0^b (1/4 - 1/2 x/b + 1/4 x^2/b^2) 1/EJ dx = [1/4 x - 1/4 x^2/b + 1/12 x^3/b^2]_0^b 1/EJ$$

$$= (1/4 b - 1/4 b + 1/12 b) 1/EJ = 1/12 b/EJ$$

$$L_{AG}^{xx} = \int_0^b (1/4 x^2/b^2) 1/EJ dx = [1/12 x^3/b^2]_0^b 1/EJ$$

$$= (1/12 b) 1/EJ = 1/12 b/EJ$$

$$L_{FG}^{xo} = \int_0^b (1/2 x^2/b^2) Fb 1/EJ dx + \int_0^b (1/2 x/b) \theta dx = [1/6 x^3/b^2]_0^b Fb 1/EJ + [1/4 x^2/b]_0^b \theta$$

$$= (1/6 b) Fb 1/EJ + (1/4 b) \theta = 5/12 Fb^2/EJ$$

$$L_{GF}^{xo} = \int_0^b (1/2 - x/b + 1/2 x^2/b^2) Fb 1/EJ dx + \int_0^b (-1/2 + 1/2 x/b) \theta dx$$

$$= [1/2 x - 1/2 x^2/b + 1/6 x^3/b^2]_0^b Fb 1/EJ + [-1/2 x + 1/4 x^2/b]_0^b \theta$$

$$= (1/2 b - 1/2 b + 1/6 b) Fb 1/EJ + (-1/2 b + 1/4 b) \theta = 5/12 Fb^2/EJ$$

$$L_{GD}^{xo} = \int_0^b (2 x/b - 3/2 x^2/b^2 - 1/2 x^3/b^3) Fb 1/EJ dx = [x^2/b - 1/2 x^3/b^2 - 1/8 x^4/b^3]_0^b Fb 1/EJ$$

$$= (b - 1/2 b - 1/8 b) Fb 1/EJ = 3/8 Fb^2/EJ$$

$$L_{DG}^{xo} = \int_0^b (5/2 x/b - 3 x^2/b^2 + 1/2 x^3/b^3) Fb 1/EJ dx = [5/4 x^2/b - x^3/b^2 + 1/8 x^4/b^3]_0^b Fb 1/EJ$$

$$= (5/4 b - b + 1/8 b) Fb 1/EJ = 3/8 Fb^2/EJ$$

$$L_{GA}^{xo} = \int_0^b (-1/2 + x/b - 1/2 x^2/b^2) Fb 1/EJ dx = [-1/2 x + 1/2 x^2/b - 1/6 x^3/b^2]_0^b Fb 1/EJ$$

$$= (-1/2 b + 1/2 b - 1/6 b) Fb 1/EJ = -1/6 Fb^2/EJ$$

$$L_{AG}^{xo} = \int_0^b (-1/2 x^2/b^2) Fb 1/EJ dx = [-1/6 x^3/b^2]_0^b Fb 1/EJ$$

$$= (-1/6 b) Fb 1/EJ = -1/6 Fb^2/EJ$$

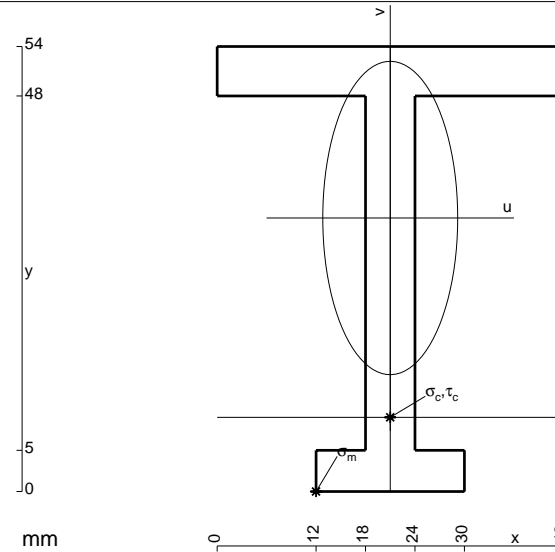

$$A = 600. \text{ mm}^2$$

$$J_u = 216946. \text{ mm}^4$$

$$J_v = 40248. \text{ mm}^4$$

$$y_g = 33.19 \text{ mm}$$

$$T_y = -1720. \text{ N}$$

$$M_x = -1307200. \text{ Nmm}$$

$$x_m = 12. \text{ mm}$$

$$u_m = -9. \text{ mm}$$

$$v_m = -33.19 \text{ mm}$$

$$\sigma_m = -Mv/J_u = -200. \text{ N/mm}^2$$

$$x_c = 21. \text{ mm}$$

$$y_c = 9. \text{ mm}$$

$$v_c = -24.19 \text{ mm}$$

$$\sigma_c = -Mv/J_u = -145.8 \text{ N/mm}^2$$

$$\tau_c = 4.48 \text{ N/mm}^2$$

$$\sigma_\rho = \sqrt{\sigma^2 + 3\tau^2} = 146. \text{ N/mm}^2$$

$$S = 3391. \text{ mm}^3$$

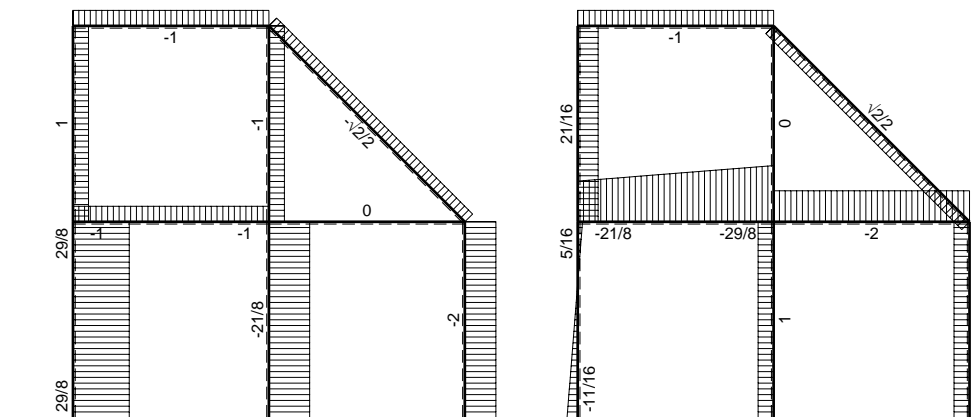
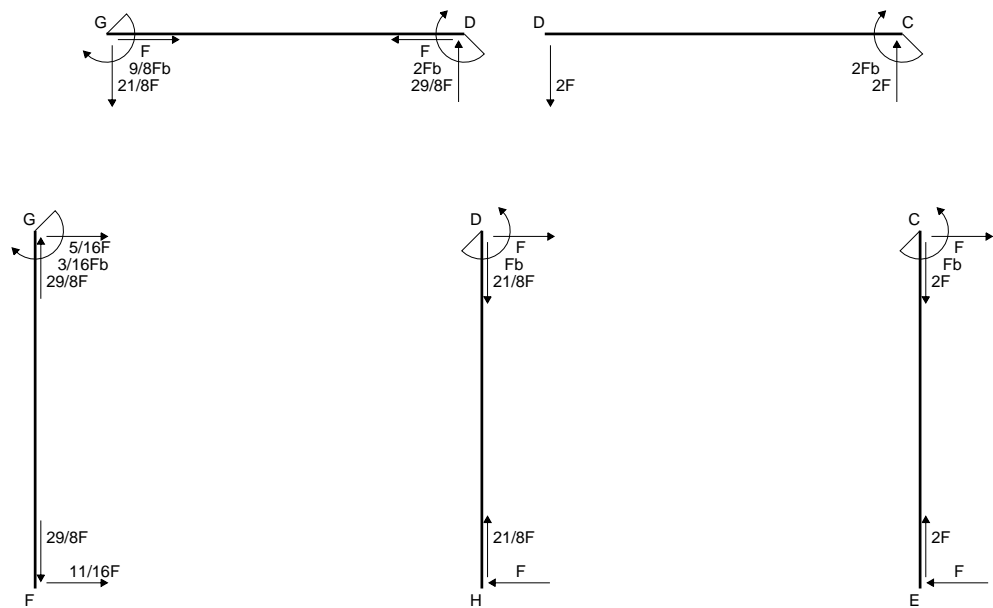
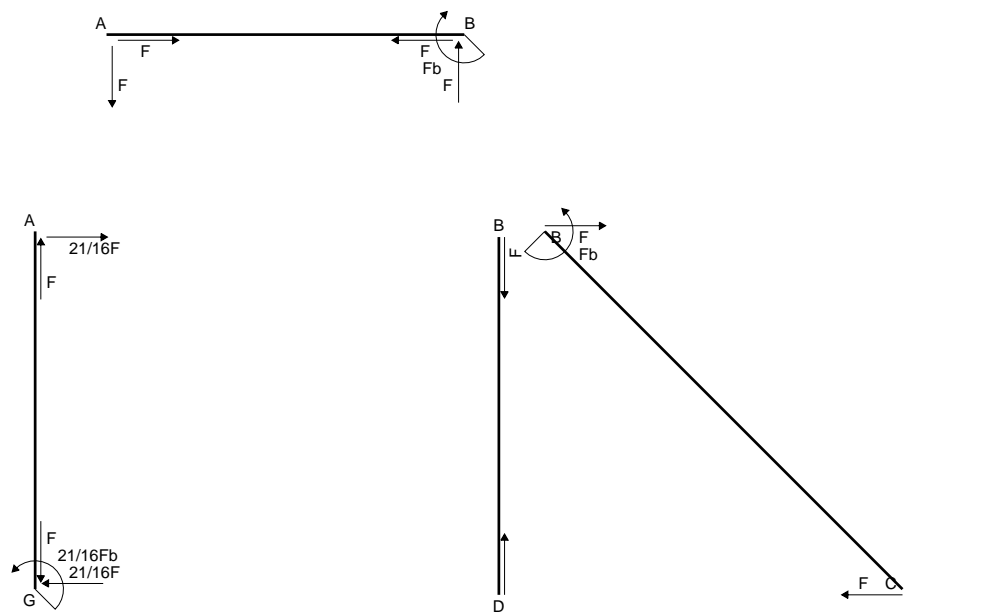

← ⊕ → F

↑ ⊕ ↓ F_b

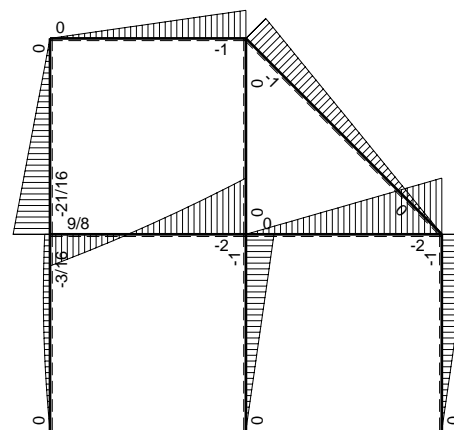

⊕ ⊖ F_b

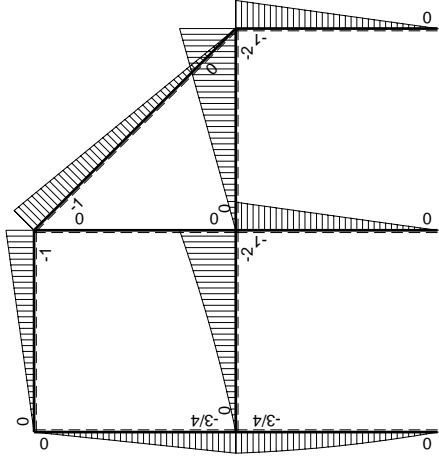
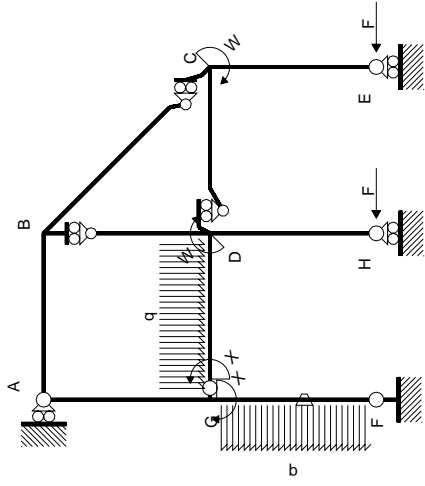

Schema di calcolo iperstatico

M_0 flessione da carichi assegnati



M_x flessione da iperstatica $X=1$

Quadro contributi PLV per iperstatica $X=W_{GD}$

→	$M_x(x)$	$M_o(x)$	θ	$M_x M_o$	$M_x \theta$	$M_x M_x$	$\int M_x(M_o/EJ+\theta)dx$	$\int x M_x M_x/EJ dx$
AB b	0	-Fx	0	0	0	0	0+0	0
BA b	0	Fb-Fx	0	0	0	0	0	0
BC $\sqrt{2}b$	0	-Fb+ $\sqrt{2}/2Fx$	0	0	0	0	0	0
BD b	0	0	0	0	0	0	0+0	0
DB b	0	0	0	0	0	0	0	0
DC b	0	-2Fx	0	0	0	0	0+0	0
CD b	0	2Fb-2Fx	0	0	0	0	0	0
CE b	0	-Fb+Fx	0	0	0	0	0+0	0
EC b	0	Fx	0	0	0	0	0	0
FG b	-1/2x/b	-5/4Fx+1/2qx ²	-Fb/EJ	5/8Fx ² /b-1/4qx ³ /b	1/2Fx/EJ	1/4x ² /b ²	(7/48+1/4)Fb ² /EJ	1/12Xb/EJ
GF b	1/2-1/2x/b	3/4Fb-1/4Fx-1/2qx ²	Fb/EJ	3/8Fb-1/2Fx-1/8Fx ² /b+1/4qx ³ /b	1/2Fb/EJ-1/2Fx/EJ	1/4-1/2x/b+1/4x ² /b ²		
GD b	-1+x/b	-3/2Fx-1/2qx ²	0	3/2Fx-Fx ² /b-1/2qx ³ /b	0	1-2x/b+x ² /b ²	(7/24+0)Fb ² /EJ	1/3Xb/EJ
DG b	x/b	2Fb-5/2Fx+1/2qx ²	0	2Fx-5/2Fx ² /b+1/2qx ³ /b	0	x ² /b ²		
DH b	0	-Fb+Fx	0	0	0	0	0+0	0
HD b	0	Fx	0	0	0	0	0	0
GA b	1/2-1/2x/b	-3/4Fb+3/4Fx	0	-3/8Fb+3/4Fx-3/8Fx ² /b	0	1/4-1/2x/b+1/4x ² /b ²	(-1/8+0)Fb ² /EJ	1/12Xb/EJ
AG b	-1/2x/b	3/4Fx	0	-3/8Fx ² /b	0	1/4x ² /b ²		
	totali						9/16Fb ² /EJ	1/2Xb/EJ
	iperstatica $X=W_{GD}$						-9/8Fb	

Sviluppi di calcolo iperstatica

$$L_{FG}^{xx} = \int_0^b (1/4 x^2/b^2) 1/EJ dx = [1/12 x^3/b^2]_0^b 1/EJ$$

$$= (1/12 b) 1/EJ = 1/12 b/EJ$$

$$L_{GF}^{xx} = \int_0^b (1/4 - 1/2 x/b + 1/4 x^2/b^2) 1/EJ dx = [1/4 x - 1/4 x^2/b + 1/12 x^3/b^2]_0^b 1/EJ$$

$$= (1/4 b - 1/4 b + 1/12 b) 1/EJ = 1/12 b/EJ$$

$$L_{GD}^{xx} = \int_0^b (1 - 2 x/b + x^2/b^2) 1/EJ dx = [x - x^2/b + 1/3 x^3/b^2]_0^b 1/EJ$$

$$= (b - b + 1/3 b) 1/EJ = 1/3 b/EJ$$

$$L_{DG}^{xx} = \int_0^b (x^2/b^2) 1/EJ dx = [1/3 x^3/b^2]_0^b 1/EJ$$

$$= (1/3 b) 1/EJ = 1/3 b/EJ$$

$$L_{GA}^{xx} = \int_0^b (1/4 - 1/2 x/b + 1/4 x^2/b^2) 1/EJ dx = [1/4 x - 1/4 x^2/b + 1/12 x^3/b^2]_0^b 1/EJ$$

$$= (1/4 b - 1/4 b + 1/12 b) 1/EJ = 1/12 b/EJ$$

$$L_{AG}^{xx} = \int_0^b (1/4 x^2/b^2) 1/EJ dx = [1/12 x^3/b^2]_0^b 1/EJ$$

$$= (1/12 b) 1/EJ = 1/12 b/EJ$$

$$L_{FG}^{xo} = \int_0^b (5/8 x^2/b^2 - 1/4 x^3/b^3) Fb 1/EJ dx + \int_0^b (1/2 x/b) \theta dx$$

$$= [5/24 x^3/b^2 - 1/16 x^4/b^3]_0^b Fb 1/EJ + [1/4 x^2/b]_0^b \theta$$

$$= (5/24 b - 1/16 b) Fb 1/EJ + (1/4 b) \theta = 19/48 Fb^2/EJ$$

$$L_{GF}^{xo} = \int_0^b (3/8 - 1/2 x/b - 1/8 x^2/b^2 + 1/4 x^3/b^3) Fb 1/EJ dx + \int_0^b (-1/2 + 1/2 x/b) \theta dx$$

$$= [3/8 x - 1/4 x^2/b - 1/24 x^3/b^2 + 1/16 x^4/b^3]_0^b Fb 1/EJ + [-1/2 x + 1/4 x^2/b]_0^b \theta$$

$$= (3/8 b - 1/4 b - 1/24 b + 1/16 b) Fb 1/EJ + (-1/2 b + 1/4 b) \theta = 19/48 Fb^2/EJ$$

$$L_{GD}^{xo} = \int_0^b (3/2 x/b - x^2/b^2 - 1/2 x^3/b^3) Fb 1/EJ dx = [3/4 x^2/b - 1/3 x^3/b^2 - 1/8 x^4/b^3]_0^b Fb 1/EJ$$

$$= (3/4 b - 1/3 b - 1/8 b) Fb 1/EJ = 7/24 Fb^2/EJ$$

$$L_{DG}^{xo} = \int_0^b (2 x/b - 5/2 x^2/b^2 + 1/2 x^3/b^3) Fb 1/EJ dx = [x^2/b - 5/6 x^3/b^2 + 1/8 x^4/b^3]_0^b Fb 1/EJ$$

$$= (b - 5/6 b + 1/8 b) Fb 1/EJ = 7/24 Fb^2/EJ$$

$$L_{GA}^{xo} = \int_0^b (-3/8 + 3/4 x/b - 3/8 x^2/b^2) Fb 1/EJ dx = [-3/8 x + 3/8 x^2/b - 1/8 x^3/b^2]_0^b Fb 1/EJ$$

$$= (-3/8 b + 3/8 b - 1/8 b) Fb 1/EJ = -1/8 Fb^2/EJ$$

$$L_{AG}^{xo} = \int_0^b (-3/8 x^2/b^2) Fb 1/EJ dx = [-1/8 x^3/b^2]_0^b Fb 1/EJ$$

$$= (-1/8 b) Fb 1/EJ = -1/8 Fb^2/EJ$$

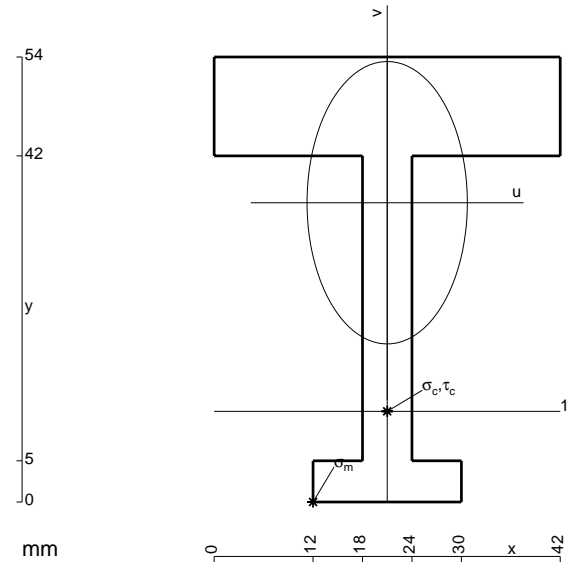

$$A = 816. \text{ mm}^2$$

$$J_u = 239746. \text{ mm}^4$$

$$J_v = 77184. \text{ mm}^4$$

$$y_g = 36.32 \text{ mm}$$

$$T_y = -1700. \text{ N}$$

$$M_x = -1377000. \text{ Nmm}$$

$$x_m = 12. \text{ mm}$$

$$u_m = -9. \text{ mm}$$

$$v_m = -36.32 \text{ mm}$$

$$\sigma_m = -Mv/J_u = -208.6 \text{ N/mm}^2$$

$$x_c = 21. \text{ mm}$$

$$y_c = 11. \text{ mm}$$

$$v_c = -25.32 \text{ mm}$$

$$\sigma_c = -Mv/J_u = -145.4 \text{ N/mm}^2$$

$$\tau_c = 4.801 \text{ N/mm}^2$$

$$\sigma_q = \sqrt{\sigma^2 + 3\tau^2} = 145.6 \text{ N/mm}^2$$

$$S = 4063. \text{ mm}^3$$

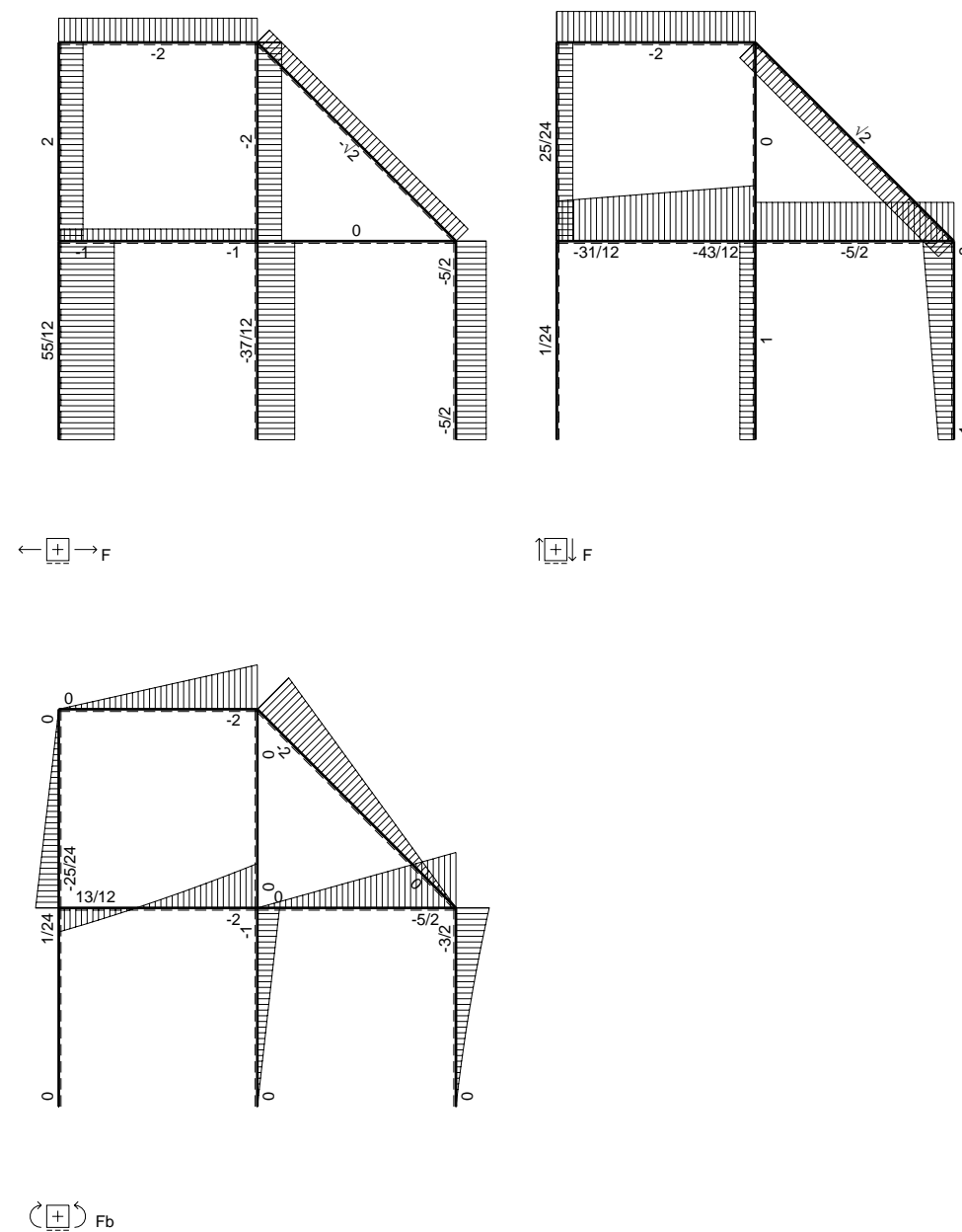
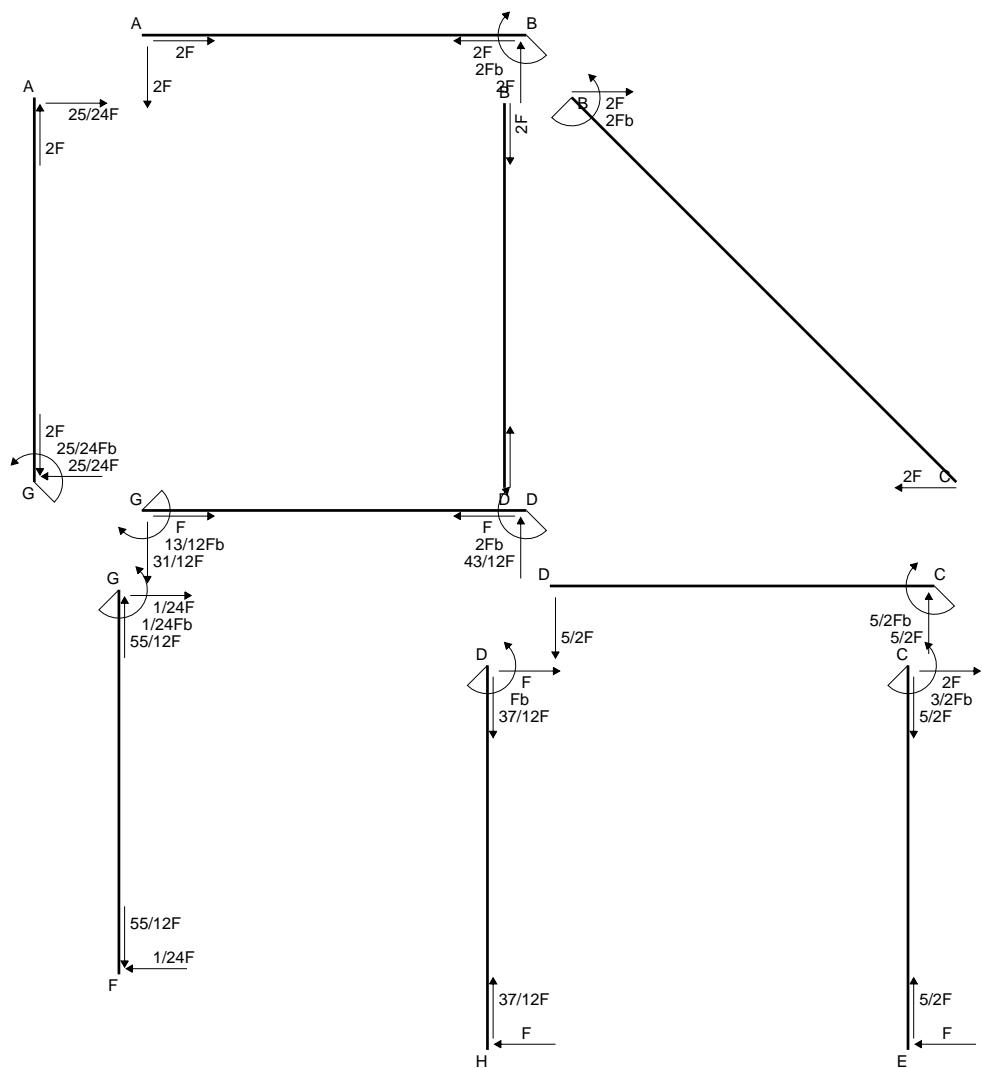

Quadro contributi PLV per iperstatica $X=W_{GD}$

→	$M_x(x)$	$M_o(x)$	θ	$M_x M_o$	$M_x \theta$	$M_x M_x$	$\int M_x(M_o/EJ+\theta)dx$	$\int X M_x M_x/EJ dx$	
AB b	0	-2Fx	0	0	0	0	0+0	0	
BA b	0	2Fb-2Fx	0	0	0	0	0	0	
BC $\sqrt{2}b$	0	-2Fb+ $\sqrt{2}Fx$	0	0	0	0	0	0	
BD b	0	0	0	0	0	0	0+0	0	
DB b	0	0	0	0	0	0	0	0	
DC b	0	-5/2Fx	0	0	0	0	0+0	0	
CD b	0	5/2Fb-5/2Fx	0	0	0	0	0	0	
CE b	0	-3/2Fb+2Fx-1/2qx ²	0	0	0	0	0+0	0	
EC b	0	Fx+1/2qx ²	0	0	0	0	0	0	
FG b	-1/2x/b	-1/2Fx	-Fb/EJ	1/4Fx ² /b	1/2Fx/EJ	1/4x ² /b ²	(1/12+1/4)Fb ² /EJ	1/12Xb/EJ	
GF b	1/2-1/2x/b	1/2Fb-1/2Fx	Fb/EJ	1/4Fb-1/2Fx+1/4Fx ² /b	1/2Fb/EJ-1/2Fx/EJ	1/4-1/2x/b+1/4x ² /b ²			
GD b	-1+x/b	-3/2Fx-1/2qx ²	0	3/2Fx-Fx ² /b-1/2qx ³ /b	0	1-2x/b+x ² /b ²	(7/24+0)Fb ² /EJ	1/3Xb/EJ	
DG b	x/b	2Fb-5/2Fx+1/2qx ²	0	2Fx-5/2Fx ² /b+1/2qx ³ /b	0	x ² /b ²			
DH b	0	-Fb+Fx	0	0	0	0	0+0	0	
HD b	0	Fx	0	0	0	0	0	0	
GA b	1/2-1/2x/b	-1/2Fb+1/2Fx	0	-1/4Fb+1/2Fx-1/4Fx ² /b	0	1/4-1/2x/b+1/4x ² /b ²	(-1/12+0)Fb ² /EJ	1/12Xb/EJ	
AG b	-1/2x/b	1/2Fx	0	-1/4Fx ² /b	0	1/4x ² /b ²			
	totali							13/24Fb ² /EJ	1/2Xb/EJ
	iperstatica $X=W_{GD}$							-13/12Fb	

Sviluppi di calcolo iperstatica

$$L_{FG}^{xx} = \int_0^b (1/4 x^2/b^2) 1/EJ dx = [1/12 x^3/b^2]_0^b 1/EJ$$

$$= (1/12 b) 1/EJ = 1/12 b/EJ$$

$$L_{GF}^{xx} = \int_0^b (1/4 - 1/2 x/b + 1/4 x^2/b^2) 1/EJ dx = [1/4 x - 1/4 x^2/b + 1/12 x^3/b^2]_0^b 1/EJ$$

$$= (1/4 b - 1/4 b + 1/12 b) 1/EJ = 1/12 b/EJ$$

$$L_{GD}^{xx} = \int_0^b (1 - 2 x/b + x^2/b^2) 1/EJ dx = [x - x^2/b + 1/3 x^3/b^2]_0^b 1/EJ$$

$$= (b - b + 1/3 b) 1/EJ = 1/3 b/EJ$$

$$L_{DG}^{xx} = \int_0^b (x^2/b^2) 1/EJ dx = [1/3 x^3/b^2]_0^b 1/EJ$$

$$= (1/3 b) 1/EJ = 1/3 b/EJ$$

$$L_{GA}^{xx} = \int_0^b (1/4 - 1/2 x/b + 1/4 x^2/b^2) 1/EJ dx = [1/4 x - 1/4 x^2/b + 1/12 x^3/b^2]_0^b 1/EJ$$

$$= (1/4 b - 1/4 b + 1/12 b) 1/EJ = 1/12 b/EJ$$

$$L_{AG}^{xx} = \int_0^b (1/4 x^2/b^2) 1/EJ dx = [1/12 x^3/b^2]_0^b 1/EJ$$

$$= (1/12 b) 1/EJ = 1/12 b/EJ$$

$$L_{FG}^{xo} = \int_0^b (1/4 x^2/b^2) Fb 1/EJ dx + \int_0^b (1/2 x/b) \theta dx = [1/12 x^3/b^2]_0^b Fb 1/EJ + [1/4 x^2/b]_0^b \theta$$

$$= (1/12 b) Fb 1/EJ + (1/4 b) \theta = 1/3 Fb^2/EJ$$

$$L_{GF}^{xo} = \int_0^b (1/4 - 1/2 x/b + 1/4 x^2/b^2) Fb 1/EJ dx + \int_0^b (-1/2 + 1/2 x/b) \theta dx$$

$$= [1/4 x - 1/4 x^2/b + 1/12 x^3/b^2]_0^b Fb 1/EJ + [-1/2 x + 1/4 x^2/b]_0^b \theta$$

$$= (1/4 b - 1/4 b + 1/12 b) Fb 1/EJ + (-1/2 b + 1/4 b) \theta = 1/3 Fb^2/EJ$$

$$L_{GD}^{xo} = \int_0^b (3/2 x/b - x^2/b^2 - 1/2 x^3/b^3) Fb 1/EJ dx = [3/4 x^2/b - 1/3 x^3/b^2 - 1/8 x^4/b^3]_0^b Fb 1/EJ$$

$$= (3/4 b - 1/3 b - 1/8 b) Fb 1/EJ = 7/24 Fb^2/EJ$$

$$L_{DG}^{xo} = \int_0^b (2 x/b - 5/2 x^2/b^2 + 1/2 x^3/b^3) Fb 1/EJ dx = [x^2/b - 5/6 x^3/b^2 + 1/8 x^4/b^3]_0^b Fb 1/EJ$$

$$= (b - 5/6 b + 1/8 b) Fb 1/EJ = 7/24 Fb^2/EJ$$

$$L_{GA}^{xo} = \int_0^b (-1/4 + 1/2 x/b - 1/4 x^2/b^2) Fb 1/EJ dx = [-1/4 x + 1/4 x^2/b - 1/12 x^3/b^2]_0^b Fb 1/EJ$$

$$= (-1/4 b + 1/4 b - 1/12 b) Fb 1/EJ = -1/12 Fb^2/EJ$$

$$L_{AG}^{xo} = \int_0^b (-1/4 x^2/b^2) Fb 1/EJ dx = [-1/12 x^3/b^2]_0^b Fb 1/EJ$$

$$= (-1/12 b) Fb 1/EJ = -1/12 Fb^2/EJ$$

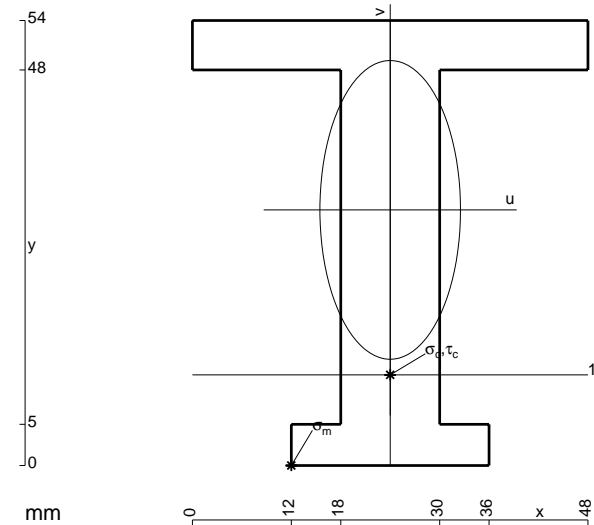

- A = 924. mm²
- J_u = 303740. mm⁴
- J_v = 67248. mm⁴
- y_g = 31.02 mm
- T_y = -2500. N
- M_x = -2150000. Nmm
- x_m = 12. mm
- u_m = -12. mm
- v_m = -31.02 mm
- σ_m = -Mv/J_u = -219.6 N/mm²
- x_c = 24. mm
- y_c = 11. mm
- v_c = -20.02 mm
- σ_c = -Mv/J_u = -141.7 N/mm²
- τ_c = 3.484 N/mm²
- σ_o = √σ²+3τ² = 141.8 N/mm²
- S = 5080. mm³

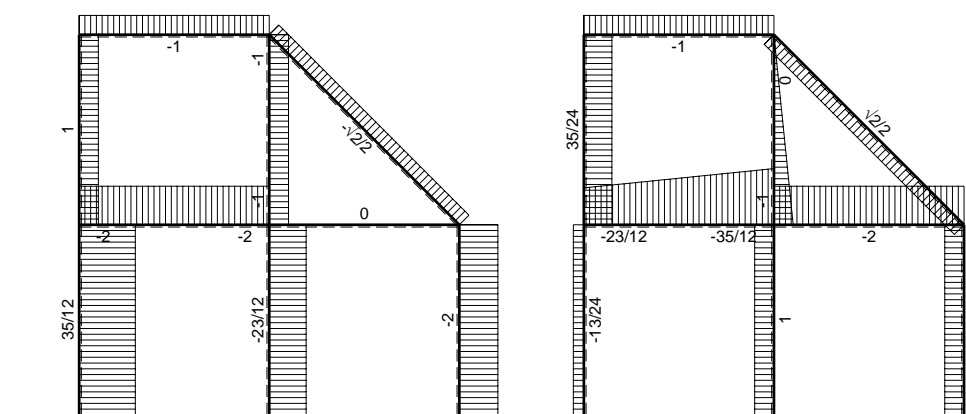
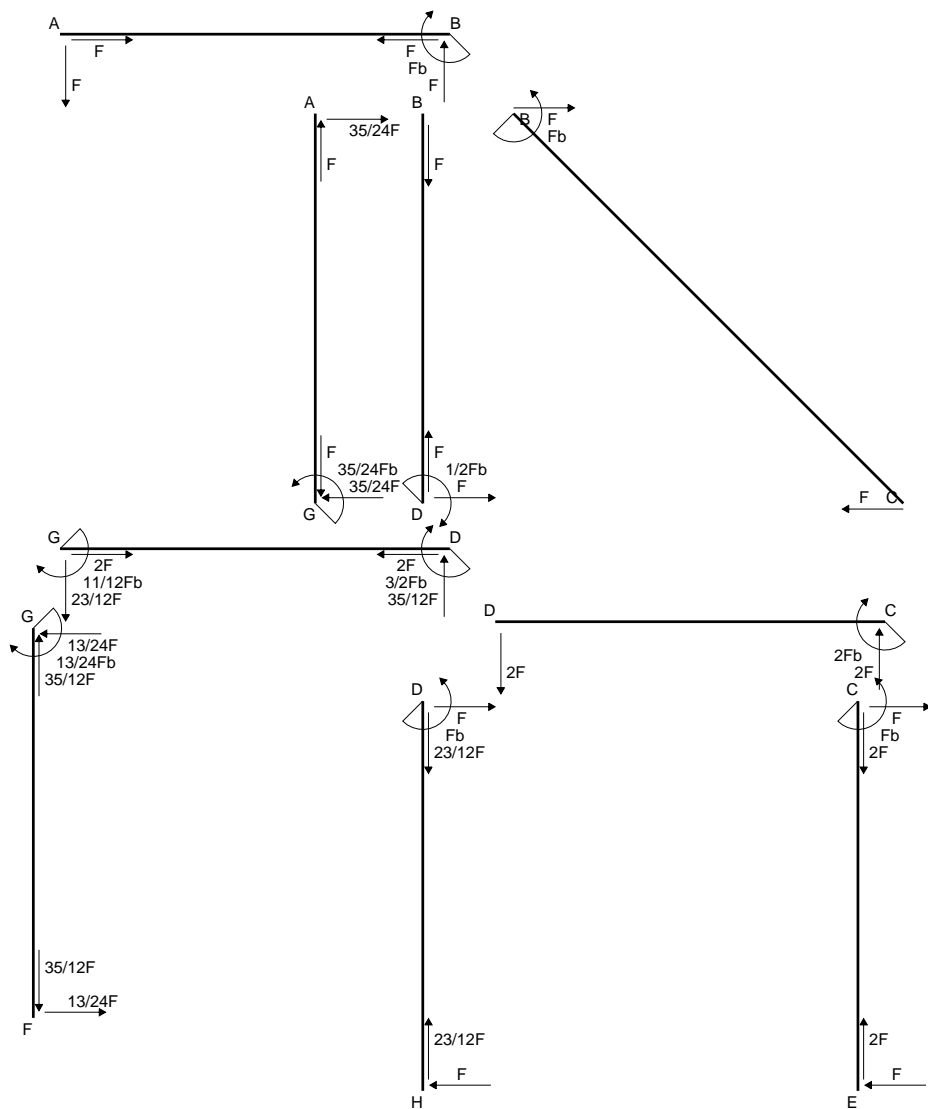

← ⊕ → F

↑ ⊕ ↓ F

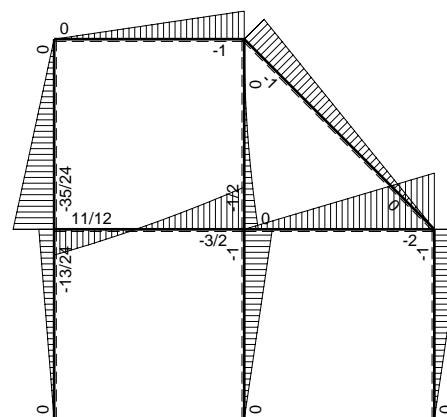

⊕ ⊖ F_b

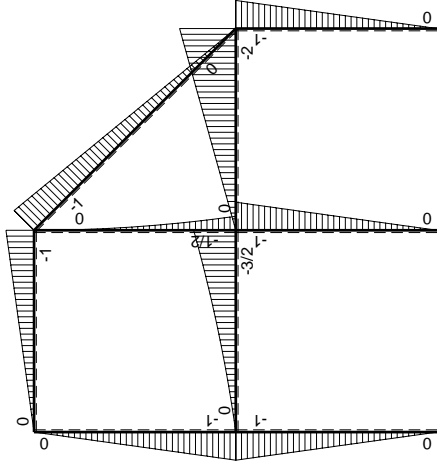
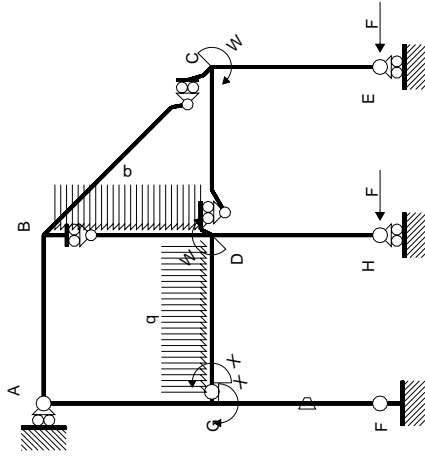

Schema di calcolo iperstatico

M_0 flessione da carichi assegnati

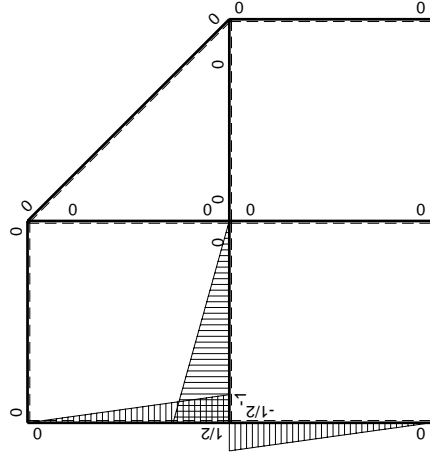

M_x flessione da iperstatica $X=1$

Quadro contributi PLV per iperstatica $X=W_{GD}$

→	$M_x(x)$	$M_o(x)$	θ	$M_x M_o$	$M_x \theta$	$M_x M_x$	$\int M_x(M_o/EJ+\theta)dx$	$\int X M_x M_x / EJ dx$
AB b	0	-Fx	0	0	0	0	0+0	0
BA b	0	Fb-Fx	0	0	0	0	0	0
BC $\sqrt{2}b$	0	-Fb+ $\sqrt{2}/2Fx$	0	0	0	0	0	0
BD b	0	-1/2qx ²	0	0	0	0	0+0	0
DB b	0	1/2Fb-Fx+1/2qx ²	0	0	0	0	0	0
DC b	0	-2Fx	0	0	0	0	0+0	0
CD b	0	2Fb-2Fx	0	0	0	0	0	0
CE b	0	-Fb+Fx	0	0	0	0	0+0	0
EC b	0	Fx	0	0	0	0	0	0
FG b	-1/2x/b	-Fx	-Fb/EJ	1/2Fx ² /b	1/2Fx/EJ	1/4x ² /b ²	(1/6+1/4)Fb ² /EJ	1/12Xb/EJ
GF b	1/2-1/2x/b	Fb-Fx	Fb/EJ	1/2Fb-Fx+1/2Fx ² /b	1/2Fb/EJ-1/2Fx/EJ	1/4-1/2x/b+1/4x ² /b ²		
GD b	-1+x/b	-Fx-1/2qx ²	0	Fx-1/2Fx ² /b-1/2qx ³ /b	0	1-2x/b+x ² /b ²	(5/24+0)Fb ² /EJ	1/3Xb/EJ
DG b	x/b	3/2Fb-2Fx+1/2qx ²	0	3/2Fx-2Fx ² /b+1/2qx ³ /b	0	x ² /b ²		
DH b	0	-Fb+Fx	0	0	0	0	0+0	0
HD b	0	Fx	0	0	0	0	0	0
GA b	1/2-1/2x/b	-Fb+Fx	0	-1/2Fb+Fx-1/2Fx ² /b	0	1/4-1/2x/b+1/4x ² /b ²	(-1/6+0)Fb ² /EJ	1/12Xb/EJ
AG b	-1/2x/b	Fx	0	-1/2Fx ² /b	0	1/4x ² /b ²		
	totali						11/24Fb ² /EJ	1/2Xb/EJ
	iperstatica $X=W_{GD}$						-11/12Fb	

Sviluppi di calcolo iperstatica

$$L_{FG}^{xx} = \int_0^b (1/4 x^2/b^2) 1/EJ dx = [1/12 x^3/b^2]_0^b 1/EJ$$

$$= (1/12 b) 1/EJ = 1/12 b/EJ$$

$$L_{GF}^{xx} = \int_0^b (1/4 - 1/2 x/b + 1/4 x^2/b^2) 1/EJ dx = [1/4 x - 1/4 x^2/b + 1/12 x^3/b^2]_0^b 1/EJ$$

$$= (1/4 b - 1/4 b + 1/12 b) 1/EJ = 1/12 b/EJ$$

$$L_{GD}^{xx} = \int_0^b (1 - 2 x/b + x^2/b^2) 1/EJ dx = [x - x^2/b + 1/3 x^3/b^2]_0^b 1/EJ$$

$$= (b - b + 1/3 b) 1/EJ = 1/3 b/EJ$$

$$L_{DG}^{xx} = \int_0^b (x^2/b^2) 1/EJ dx = [1/3 x^3/b^2]_0^b 1/EJ$$

$$= (1/3 b) 1/EJ = 1/3 b/EJ$$

$$L_{GA}^{xx} = \int_0^b (1/4 - 1/2 x/b + 1/4 x^2/b^2) 1/EJ dx = [1/4 x - 1/4 x^2/b + 1/12 x^3/b^2]_0^b 1/EJ$$

$$= (1/4 b - 1/4 b + 1/12 b) 1/EJ = 1/12 b/EJ$$

$$L_{AG}^{xx} = \int_0^b (1/4 x^2/b^2) 1/EJ dx = [1/12 x^3/b^2]_0^b 1/EJ$$

$$= (1/12 b) 1/EJ = 1/12 b/EJ$$

$$L_{FG}^{xo} = \int_0^b (1/2 x^2/b^2) Fb 1/EJ dx + \int_0^b (1/2 x/b) \theta dx = [1/6 x^3/b^2]_0^b Fb 1/EJ + [1/4 x^2/b]_0^b \theta$$

$$= (1/6 b) Fb 1/EJ + (1/4 b) \theta = 5/12 Fb^2/EJ$$

$$L_{GF}^{xo} = \int_0^b (1/2 - x/b + 1/2 x^2/b^2) Fb 1/EJ dx + \int_0^b (-1/2 + 1/2 x/b) \theta dx$$

$$= [1/2 x - 1/2 x^2/b + 1/6 x^3/b^2]_0^b Fb 1/EJ + [-1/2 x + 1/4 x^2/b]_0^b \theta$$

$$= (1/2 b - 1/2 b + 1/6 b) Fb 1/EJ + (-1/2 b + 1/4 b) \theta = 5/12 Fb^2/EJ$$

$$L_{GD}^{xo} = \int_0^b (x/b - 1/2 x^2/b^2 - 1/2 x^3/b^3) Fb 1/EJ dx = [1/2 x^2/b - 1/6 x^3/b^2 - 1/8 x^4/b^3]_0^b Fb 1/EJ$$

$$= (1/2 b - 1/6 b - 1/8 b) Fb 1/EJ = 5/24 Fb^2/EJ$$

$$L_{DG}^{xo} = \int_0^b (3/2 x/b - 2 x^2/b^2 + 1/2 x^3/b^3) Fb 1/EJ dx = [3/4 x^2/b - 2/3 x^3/b^2 + 1/8 x^4/b^3]_0^b Fb 1/EJ$$

$$= (3/4 b - 2/3 b + 1/8 b) Fb 1/EJ = 5/24 Fb^2/EJ$$

$$L_{GA}^{xo} = \int_0^b (-1/2 + x/b - 1/2 x^2/b^2) Fb 1/EJ dx = [-1/2 x + 1/2 x^2/b - 1/6 x^3/b^2]_0^b Fb 1/EJ$$

$$= (-1/2 b + 1/2 b - 1/6 b) Fb 1/EJ = -1/6 Fb^2/EJ$$

$$L_{AG}^{xo} = \int_0^b (-1/2 x^2/b^2) Fb 1/EJ dx = [-1/6 x^3/b^2]_0^b Fb 1/EJ$$

$$= (-1/6 b) Fb 1/EJ = -1/6 Fb^2/EJ$$

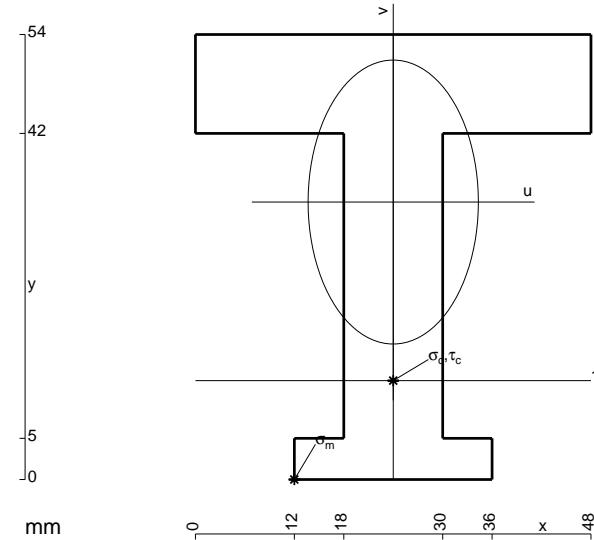

- A = 1140. mm²
- J_u = 338607. mm⁴
- J_v = 121680. mm⁴
- y_g = 33.67 mm
- T_y = -2540. N
- M_x = -2311400. Nmm
- x_m = 12. mm
- u_m = -12. mm
- v_m = -33.67 mm
- σ_m = -Mv/J_u = -229.8 N/mm²
- x_c = 24. mm
- y_c = 12. mm
- v_c = -21.67 mm
- σ_c = -Mv/J_u = -147.9 N/mm²
- τ_c = 3.66 N/mm²
- σ_ρ = √(σ² + 3τ²) = 148. N/mm²
- S = 5854. mm³

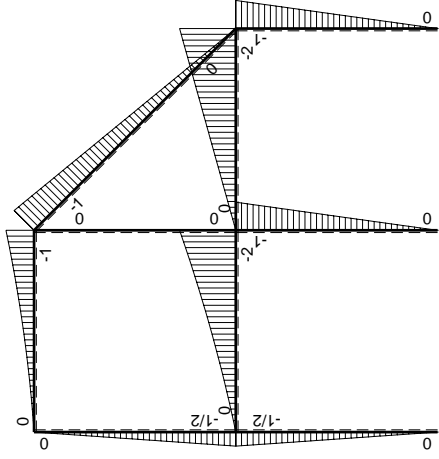
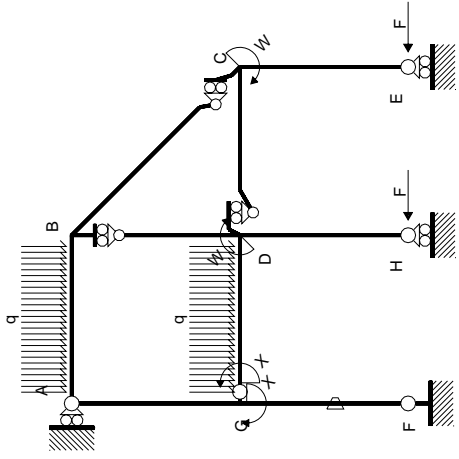

Schema di calcolo iperstatico

M_0 flessione da carichi assegnati



M_x flessione da iperstatica $X=1$

Quadro contributi PLV per iperstatica $X=W_{GD}$

→	$M_x(x)$	$M_o(x)$	θ	$M_x M_o$	$M_x \theta$	$M_x M_x$	$\int M_x(M_o/EJ+\theta)dx$	$\int X M_x M_x/EJdx$
AB b	0	$-1/2Fx-1/2qx^2$	0	0	0	0	0+0	0
BA b	0	$Fb-3/2Fx+1/2qx^2$	0	0	0	0	0	0
BC $\sqrt{2}b$	0	$-Fb+\sqrt{2}/2Fx$	0	0	0	0	0	0
BD b	0	0	0	0	0	0	0+0	0
DB b	0	0	0	0	0	0	0	0
DC b	0	$-2Fx$	0	0	0	0	0+0	0
CD b	0	$2Fb-2Fx$	0	0	0	0	0	0
CE b	0	$-Fb+Fx$	0	0	0	0	0+0	0
EC b	0	Fx	0	0	0	0	0	0
FG b	$-1/2x/b$	$-1/2Fx$	$-Fb/EJ$	$1/4Fx^2/b$	$1/2Fx/EJ$	$1/4x^2/b^2$	$(1/12+1/4)Fb^2/EJ$	$1/12Xb/EJ$
GF b	$1/2-1/2x/b$	$1/2Fb-1/2Fx$	Fb/EJ	$1/4Fb-1/2Fx+1/4Fx^2/b$	$1/2Fb/EJ-1/2Fx/EJ$	$1/4-1/2x/b+1/4x^2/b^2$		
GD b	$-1+x/b$	$-3/2Fx-1/2qx^2$	0	$3/2Fx-Fx^2/b-1/2qx^3/b$	0	$1-2x/b+x^2/b^2$	$(7/24+0)Fb^2/EJ$	$1/3Xb/EJ$
DG b	x/b	$2Fb-5/2Fx+1/2qx^2$	0	$2Fx-5/2Fx^2/b+1/2qx^3/b$	0	x^2/b^2		
DH b	0	$-Fb+Fx$	0	0	0	0	0+0	0
HD b	0	Fx	0	0	0	0	0	0
GA b	$1/2-1/2x/b$	$-1/2Fb+1/2Fx$	0	$-1/4Fb+1/2Fx-1/4Fx^2/b$	0	$1/4-1/2x/b+1/4x^2/b^2$	$(-1/12+0)Fb^2/EJ$	$1/12Xb/EJ$
AG b	$-1/2x/b$	$1/2Fx$	0	$-1/4Fx^2/b$	0	$1/4x^2/b^2$		
	totali						$13/24Fb^2/EJ$	$1/2Xb/EJ$
	iperstatica $X=W_{GD}$						$-13/12Fb$	

Sviluppi di calcolo iperstatica

$$L_{FG}^{xx} = \int_0^b (1/4 x^2/b^2) 1/EJ dx = [1/12 x^3/b^2]_0^b 1/EJ$$

$$= (1/12 b) 1/EJ = 1/12 b/EJ$$

$$L_{GF}^{xx} = \int_0^b (1/4 - 1/2 x/b + 1/4 x^2/b^2) 1/EJ dx = [1/4 x - 1/4 x^2/b + 1/12 x^3/b^2]_0^b 1/EJ$$

$$= (1/4 b - 1/4 b + 1/12 b) 1/EJ = 1/12 b/EJ$$

$$L_{GD}^{xx} = \int_0^b (1 - 2 x/b + x^2/b^2) 1/EJ dx = [x - x^2/b + 1/3 x^3/b^2]_0^b 1/EJ$$

$$= (b - b + 1/3 b) 1/EJ = 1/3 b/EJ$$

$$L_{DG}^{xx} = \int_0^b (x^2/b^2) 1/EJ dx = [1/3 x^3/b^2]_0^b 1/EJ$$

$$= (1/3 b) 1/EJ = 1/3 b/EJ$$

$$L_{GA}^{xx} = \int_0^b (1/4 - 1/2 x/b + 1/4 x^2/b^2) 1/EJ dx = [1/4 x - 1/4 x^2/b + 1/12 x^3/b^2]_0^b 1/EJ$$

$$= (1/4 b - 1/4 b + 1/12 b) 1/EJ = 1/12 b/EJ$$

$$L_{AG}^{xx} = \int_0^b (1/4 x^2/b^2) 1/EJ dx = [1/12 x^3/b^2]_0^b 1/EJ$$

$$= (1/12 b) 1/EJ = 1/12 b/EJ$$

$$L_{FG}^{xo} = \int_0^b (1/4 x^2/b^2) Fb 1/EJ dx + \int_0^b (1/2 x/b) \theta dx = [1/12 x^3/b^2]_0^b Fb 1/EJ + [1/4 x^2/b]_0^b \theta$$

$$= (1/12 b) Fb 1/EJ + (1/4 b) \theta = 1/3 Fb^2/EJ$$

$$L_{GF}^{xo} = \int_0^b (1/4 - 1/2 x/b + 1/4 x^2/b^2) Fb 1/EJ dx + \int_0^b (-1/2 + 1/2 x/b) \theta dx$$

$$= [1/4 x - 1/4 x^2/b + 1/12 x^3/b^2]_0^b Fb 1/EJ + [-1/2 x + 1/4 x^2/b]_0^b \theta$$

$$= (1/4 b - 1/4 b + 1/12 b) Fb 1/EJ + (-1/2 b + 1/4 b) \theta = 1/3 Fb^2/EJ$$

$$L_{GD}^{xo} = \int_0^b (3/2 x/b - x^2/b^2 - 1/2 x^3/b^3) Fb 1/EJ dx = [3/4 x^2/b - 1/3 x^3/b^2 - 1/8 x^4/b^3]_0^b Fb 1/EJ$$

$$= (3/4 b - 1/3 b - 1/8 b) Fb 1/EJ = 7/24 Fb^2/EJ$$

$$L_{DG}^{xo} = \int_0^b (2 x/b - 5/2 x^2/b^2 + 1/2 x^3/b^3) Fb 1/EJ dx = [x^2/b - 5/6 x^3/b^2 + 1/8 x^4/b^3]_0^b Fb 1/EJ$$

$$= (b - 5/6 b + 1/8 b) Fb 1/EJ = 7/24 Fb^2/EJ$$

$$L_{GA}^{xo} = \int_0^b (-1/4 + 1/2 x/b - 1/4 x^2/b^2) Fb 1/EJ dx = [-1/4 x + 1/4 x^2/b - 1/12 x^3/b^2]_0^b Fb 1/EJ$$

$$= (-1/4 b + 1/4 b - 1/12 b) Fb 1/EJ = -1/12 Fb^2/EJ$$

$$L_{AG}^{xo} = \int_0^b (-1/4 x^2/b^2) Fb 1/EJ dx = [-1/12 x^3/b^2]_0^b Fb 1/EJ$$

$$= (-1/12 b) Fb 1/EJ = -1/12 Fb^2/EJ$$

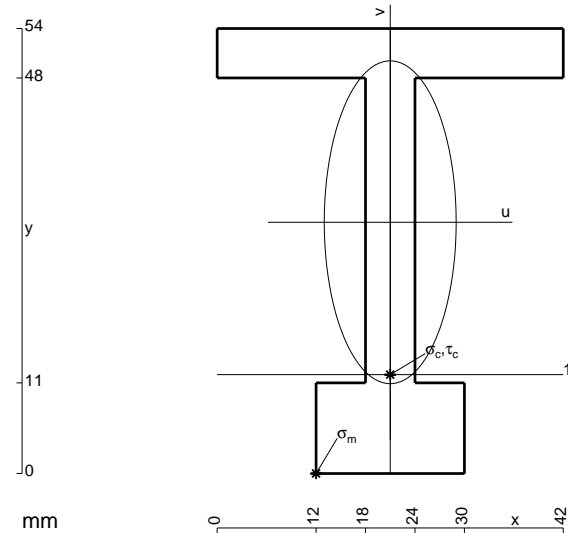

$$A = 672. \text{ mm}^2$$

$$J_u = 257954. \text{ mm}^4$$

$$J_v = 43056. \text{ mm}^4$$

$$y_g = 30.49 \text{ mm}$$

$$T_y = -2100. \text{ N}$$

$$M_x = -2016000. \text{ Nmm}$$

$$x_m = 12. \text{ mm}$$

$$u_m = -9. \text{ mm}$$

$$v_m = -30.49 \text{ mm}$$

$$\sigma_m = -Mv/J_u = -238.3 \text{ N/mm}^2$$

$$x_c = 21. \text{ mm}$$

$$y_c = 12. \text{ mm}$$

$$v_c = -18.49 \text{ mm}$$

$$\sigma_c = -Mv/J_u = -144.5 \text{ N/mm}^2$$

$$\tau_c = 6.869 \text{ N/mm}^2$$

$$\sigma_o = \sqrt{\sigma^2 + 3\tau^2} = 145. \text{ N/mm}^2$$

$$S = 5062. \text{ mm}^3$$

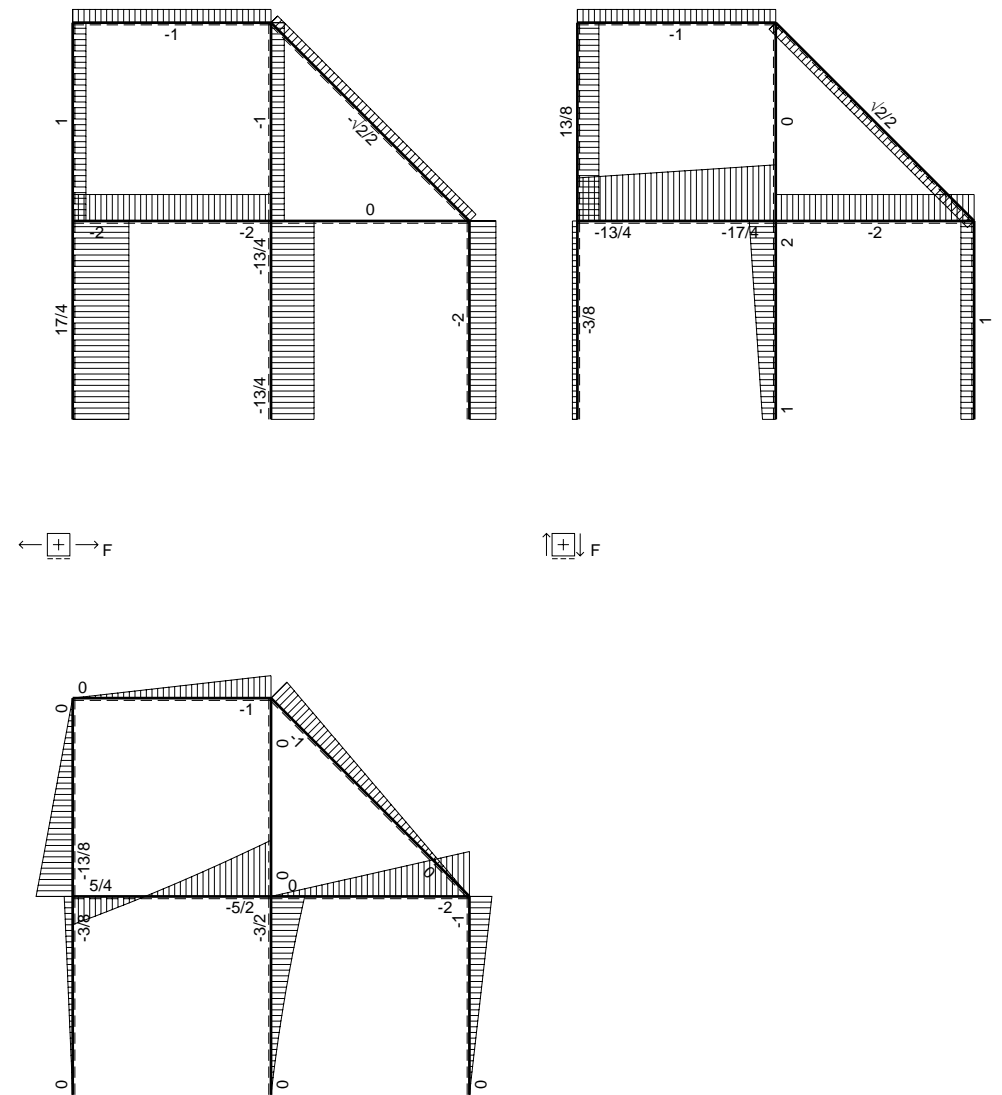
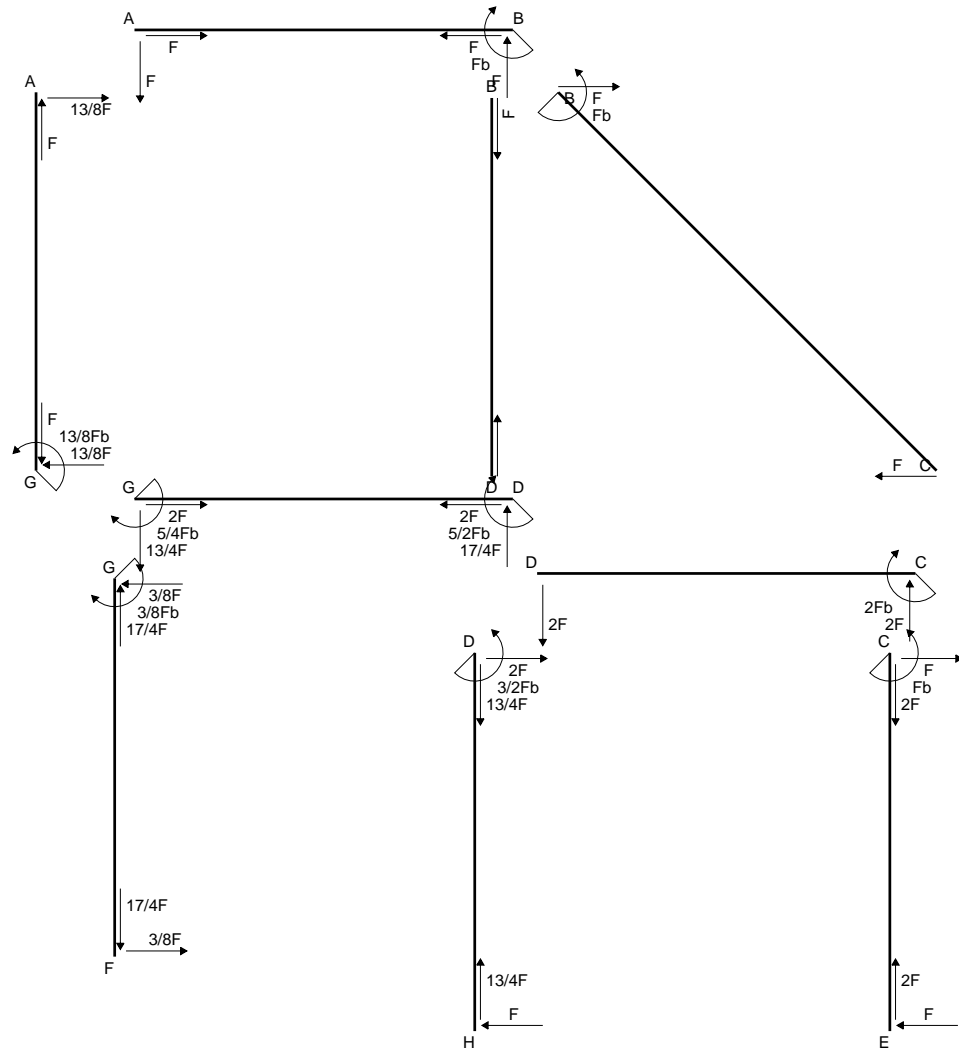

$\curvearrowright (+) F_b$

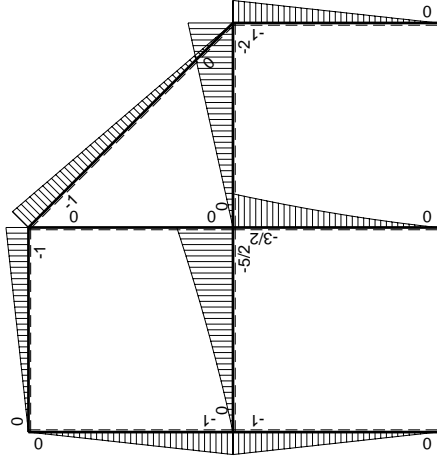
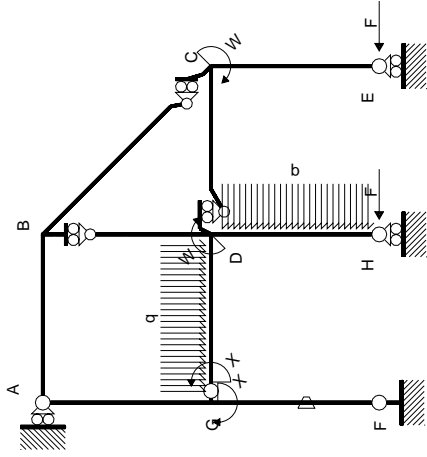

Schema di calcolo iperstatico

M_0 flessione da carichi assegnati

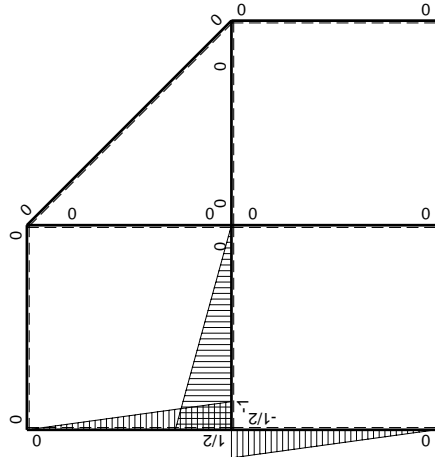

M_x flessione da iperstatica $X=1$

Quadro contributi PLV per iperstatica $X=W_{GD}$

→	$M_x(x)$	$M_o(x)$	θ	$M_x M_o$	$M_x \theta$	$M_x M_x$	$\int M_x(M_o/EJ+\theta)dx$	$\int X M_x M_x / EJ dx$
AB b	0	-Fx	0	0	0	0	0+0	0
BA b	0	Fb-Fx	0	0	0	0	0	0
BC $\sqrt{2}b$	0	-Fb+ $\sqrt{2}/2Fx$	0	0	0	0	0	0
BD b	0	0	0	0	0	0	0+0	0
DB b	0	0	0	0	0	0	0	0
DC b	0	-2Fx	0	0	0	0	0+0	0
CD b	0	2Fb-2Fx	0	0	0	0	0	0
CE b	0	-Fb+Fx	0	0	0	0	0+0	0
EC b	0	Fx	0	0	0	0	0	0
FG b	-1/2x/b	-Fx	-Fb/EJ	1/2Fx ² /b	1/2Fx/EJ	1/4x ² /b ²	(1/6+1/4)Fb ² /EJ	1/12Xb/EJ
GF b	1/2-1/2x/b	Fb-Fx	Fb/EJ	1/2Fb-Fx+1/2Fx ² /b	1/2Fb/EJ-1/2Fx/EJ	1/4-1/2x/b+1/4x ² /b ²		
GD b	-1+x/b	-2Fx-1/2qx ²	0	2Fx-3/2Fx ² /b-1/2qx ³ /b	0	1-2x/b+x ² /b ²	(3/8+0)Fb ² /EJ	1/3Xb/EJ
DG b	x/b	5/2Fb-3Fx+1/2qx ²	0	5/2Fx-3Fx ² /b+1/2qx ³ /b	0	x ² /b ²		
DH b	0	-3/2Fb+2Fx-1/2qx ²	0	0	0	0	0+0	0
HD b	0	Fx+1/2qx ²	0	0	0	0		
GA b	1/2-1/2x/b	-Fb+Fx	0	-1/2Fb+Fx-1/2Fx ² /b	0	1/4-1/2x/b+1/4x ² /b ²	(-1/6+0)Fb ² /EJ	1/12Xb/EJ
AG b	-1/2x/b	Fx	0	-1/2Fx ² /b	0	1/4x ² /b ²		
	totali						5/8Fb ² /EJ	1/2Xb/EJ
	iperstatica $X=W_{GD}$						-5/4Fb	

Sviluppi di calcolo iperstatica

$$L_{FG}^{xx} = \int_0^b (1/4 x^2/b^2) 1/EJ dx = [1/12 x^3/b^2]_0^b 1/EJ$$

$$= (1/12 b) 1/EJ = 1/12 b/EJ$$

$$L_{GF}^{xx} = \int_0^b (1/4 - 1/2 x/b + 1/4 x^2/b^2) 1/EJ dx = [1/4 x - 1/4 x^2/b + 1/12 x^3/b^2]_0^b 1/EJ$$

$$= (1/4 b - 1/4 b + 1/12 b) 1/EJ = 1/12 b/EJ$$

$$L_{GD}^{xx} = \int_0^b (1 - 2 x/b + x^2/b^2) 1/EJ dx = [x - x^2/b + 1/3 x^3/b^2]_0^b 1/EJ$$

$$= (b - b + 1/3 b) 1/EJ = 1/3 b/EJ$$

$$L_{DG}^{xx} = \int_0^b (x^2/b^2) 1/EJ dx = [1/3 x^3/b^2]_0^b 1/EJ$$

$$= (1/3 b) 1/EJ = 1/3 b/EJ$$

$$L_{GA}^{xx} = \int_0^b (1/4 - 1/2 x/b + 1/4 x^2/b^2) 1/EJ dx = [1/4 x - 1/4 x^2/b + 1/12 x^3/b^2]_0^b 1/EJ$$

$$= (1/4 b - 1/4 b + 1/12 b) 1/EJ = 1/12 b/EJ$$

$$L_{AG}^{xx} = \int_0^b (1/4 x^2/b^2) 1/EJ dx = [1/12 x^3/b^2]_0^b 1/EJ$$

$$= (1/12 b) 1/EJ = 1/12 b/EJ$$

$$L_{FG}^{xo} = \int_0^b (1/2 x^2/b^2) Fb 1/EJ dx + \int_0^b (1/2 x/b) \theta dx = [1/6 x^3/b^2]_0^b Fb 1/EJ + [1/4 x^2/b]_0^b \theta$$

$$= (1/6 b) Fb 1/EJ + (1/4 b) \theta = 5/12 Fb^2/EJ$$

$$L_{GF}^{xo} = \int_0^b (1/2 - x/b + 1/2 x^2/b^2) Fb 1/EJ dx + \int_0^b (-1/2 + 1/2 x/b) \theta dx$$

$$= [1/2 x - 1/2 x^2/b + 1/6 x^3/b^2]_0^b Fb 1/EJ + [-1/2 x + 1/4 x^2/b]_0^b \theta$$

$$= (1/2 b - 1/2 b + 1/6 b) Fb 1/EJ + (-1/2 b + 1/4 b) \theta = 5/12 Fb^2/EJ$$

$$L_{GD}^{xo} = \int_0^b (2 x/b - 3/2 x^2/b^2 - 1/2 x^3/b^3) Fb 1/EJ dx = [x^2/b - 1/2 x^3/b^2 - 1/8 x^4/b^3]_0^b Fb 1/EJ$$

$$= (b - 1/2 b - 1/8 b) Fb 1/EJ = 3/8 Fb^2/EJ$$

$$L_{DG}^{xo} = \int_0^b (5/2 x/b - 3 x^2/b^2 + 1/2 x^3/b^3) Fb 1/EJ dx = [5/4 x^2/b - x^3/b^2 + 1/8 x^4/b^3]_0^b Fb 1/EJ$$

$$= (5/4 b - b + 1/8 b) Fb 1/EJ = 3/8 Fb^2/EJ$$

$$L_{GA}^{xo} = \int_0^b (-1/2 + x/b - 1/2 x^2/b^2) Fb 1/EJ dx = [-1/2 x + 1/2 x^2/b - 1/6 x^3/b^2]_0^b Fb 1/EJ$$

$$= (-1/2 b + 1/2 b - 1/6 b) Fb 1/EJ = -1/6 Fb^2/EJ$$

$$L_{AG}^{xo} = \int_0^b (-1/2 x^2/b^2) Fb 1/EJ dx = [-1/6 x^3/b^2]_0^b Fb 1/EJ$$

$$= (-1/6 b) Fb 1/EJ = -1/6 Fb^2/EJ$$

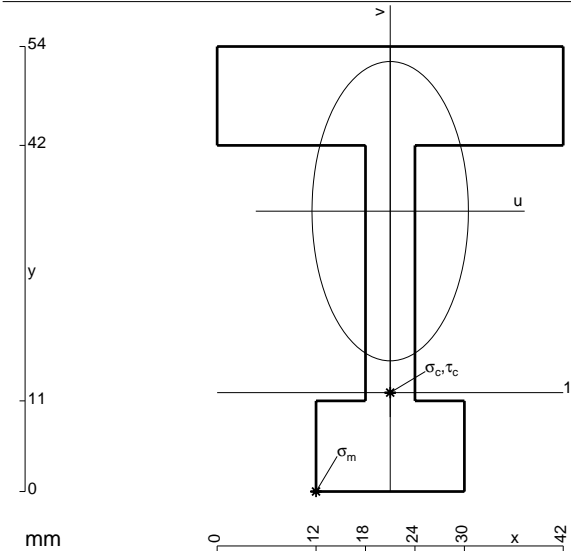

- A = 888. mm²
- J_u = 293012. mm⁴
- J_v = 79992. mm⁴
- y_g = 34.02 mm
- T_y = -3360. N
- M_x = -1713600. Nmm
- x_m = 12. mm
- u_m = -9. mm
- v_m = -34.02 mm
- σ_m = -Mv/J_u = -199. N/mm²
- x_c = 21. mm
- y_c = 12. mm
- v_c = -22.02 mm
- σ_c = -Mv/J_u = -128.8 N/mm²
- τ_c = 11.05 N/mm²
- σ_o = √σ²+3τ² = 130.2 N/mm²
- S = 5782. mm³

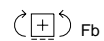
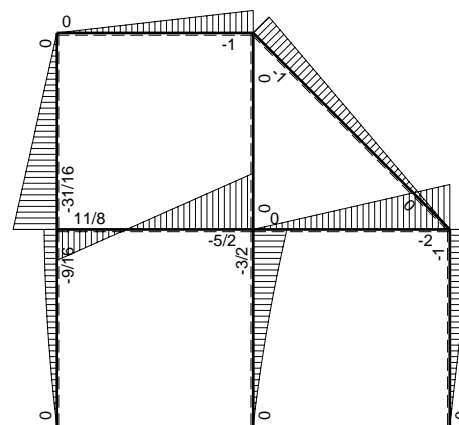
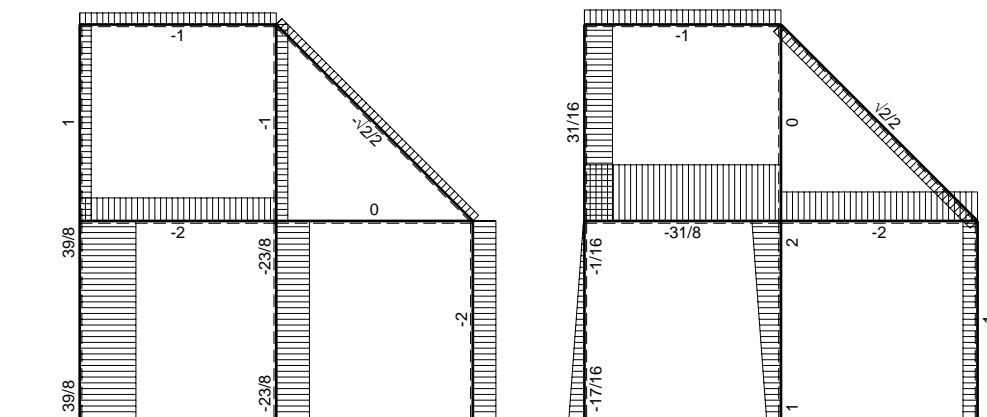
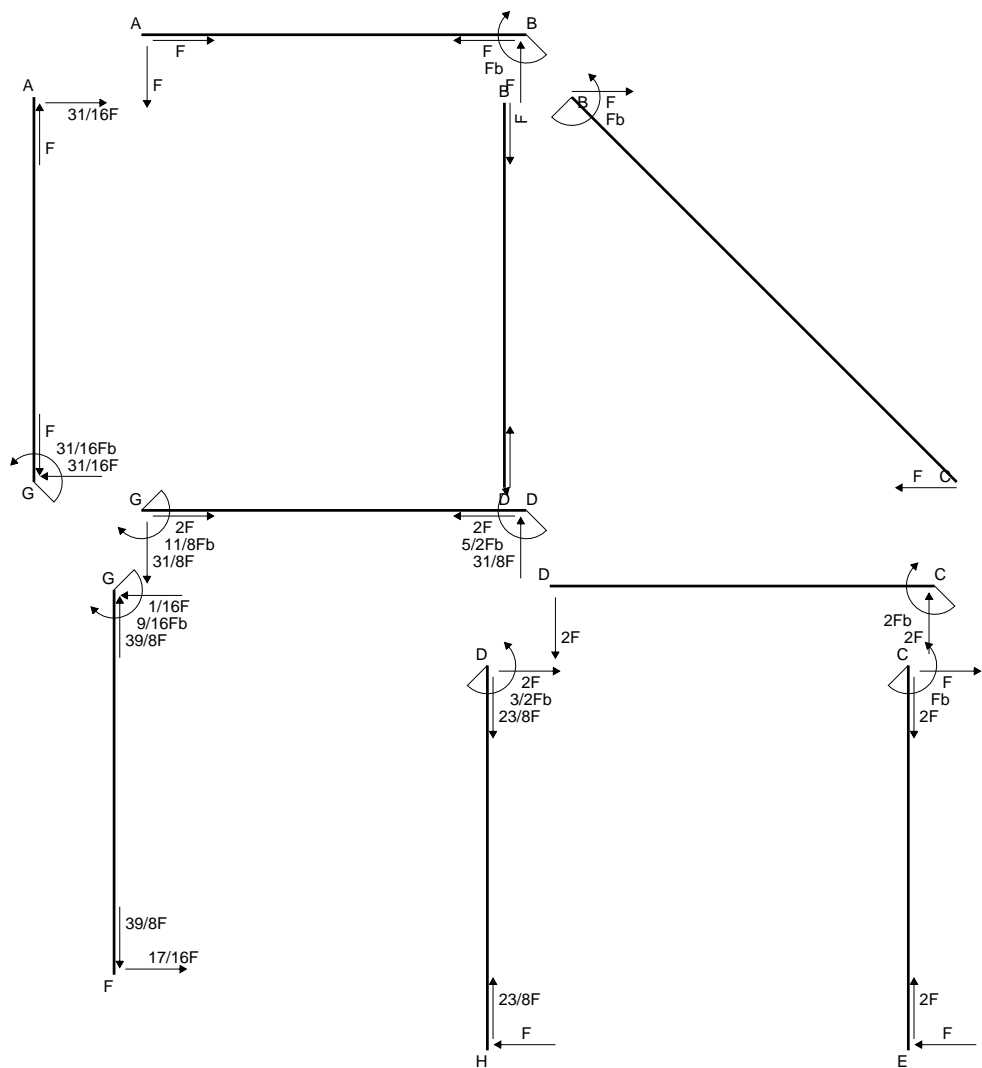

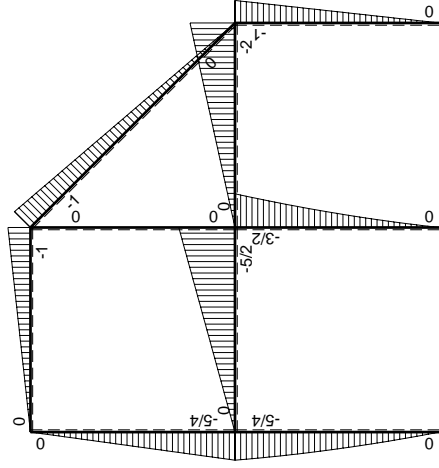
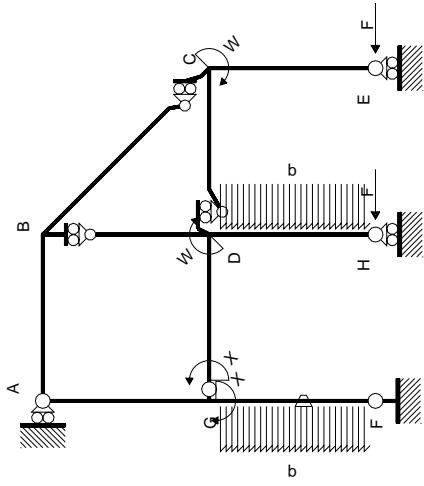

Schema di calcolo iperstatico

M_0 flessione da carichi assegnati

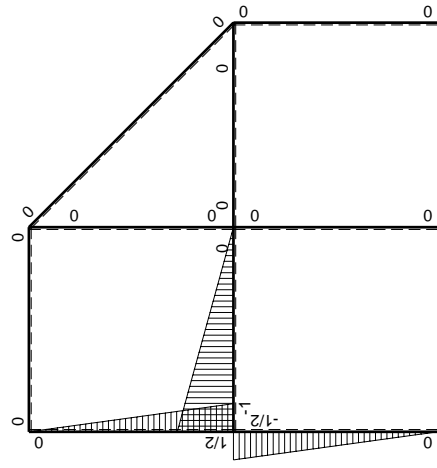

M_x flessione da iperstatica $X=1$

Quadro contributi PLV per iperstatica $X=W_{GD}$

→	$M_x(x)$	$M_o(x)$	θ	$M_x M_o$	$M_x \theta$	$M_x M_x$	$\int M_x(M_o/EJ+\theta)dx$	$\int X M_x M_x / EJ dx$
AB b	0	-Fx	0	0	0	0	0+0	0
BA b	0	Fb-Fx	0	0	0	0	0	0
BC $\sqrt{2}b$	0	-Fb+ $\sqrt{2}/2Fx$	0	0	0	0	0	0
BD b	0	0	0	0	0	0	0+0	0
DB b	0	0	0	0	0	0	0	0
DC b	0	-2Fx	0	0	0	0	0+0	0
CD b	0	2Fb-2Fx	0	0	0	0	0	0
CE b	0	-Fb+Fx	0	0	0	0	0+0	0
EC b	0	Fx	0	0	0	0	0	0
FG b	-1/2x/b	-7/4Fx+1/2qx ²	-Fb/EJ	7/8Fx ² /b-1/4qx ³ /b	1/2Fx/EJ	1/4x ² /b ²	(11/48+1/4)Fb ² /EJ	1/12Xb/EJ
GF b	1/2-1/2x/b	5/4Fb-3/4Fx-1/2qx ²	Fb/EJ	5/8Fb-Fx+1/8Fx ² /b+1/4qx ³ /b	1/2Fb/EJ-1/2Fx/EJ	1/4-1/2x/b+1/4x ² /b ²		
GD b	-1+x/b	-5/2Fx	0	5/2Fx-5/2Fx ² /b	0	1-2x/b+x ² /b ²	(5/12+0)Fb ² /EJ	1/3Xb/EJ
DG b	x/b	5/2Fb-5/2Fx	0	5/2Fx-5/2Fx ² /b	0	x ² /b ²		
DH b	0	-3/2Fb+2Fx-1/2qx ²	0	0	0	0	0+0	0
HD b	0	Fx+1/2qx ²	0	0	0	0		
GA b	1/2-1/2x/b	-5/4Fb+5/4Fx	0	-5/8Fb+5/4Fx-5/8Fx ² /b	0	1/4-1/2x/b+1/4x ² /b ²	(-5/24+0)Fb ² /EJ	1/12Xb/EJ
AG b	-1/2x/b	5/4Fx	0	-5/8Fx ² /b	0	1/4x ² /b ²		
	totali						11/16Fb ² /EJ	1/2Xb/EJ
	iperstatica $X=W_{GD}$						-11/8Fb	

Sviluppi di calcolo iperstatica

$$L_{FG}^{xx} = \int_0^b (1/4 x^2/b^2) 1/EJ dx = [1/12 x^3/b^2]_0^b 1/EJ$$

$$= (1/12 b) 1/EJ = 1/12 b/EJ$$

$$L_{GF}^{xx} = \int_0^b (1/4 - 1/2 x/b + 1/4 x^2/b^2) 1/EJ dx = [1/4 x - 1/4 x^2/b + 1/12 x^3/b^2]_0^b 1/EJ$$

$$= (1/4 b - 1/4 b + 1/12 b) 1/EJ = 1/12 b/EJ$$

$$L_{GD}^{xx} = \int_0^b (1 - 2 x/b + x^2/b^2) 1/EJ dx = [x - x^2/b + 1/3 x^3/b^2]_0^b 1/EJ$$

$$= (b - b + 1/3 b) 1/EJ = 1/3 b/EJ$$

$$L_{DG}^{xx} = \int_0^b (x^2/b^2) 1/EJ dx = [1/3 x^3/b^2]_0^b 1/EJ$$

$$= (1/3 b) 1/EJ = 1/3 b/EJ$$

$$L_{GA}^{xx} = \int_0^b (1/4 - 1/2 x/b + 1/4 x^2/b^2) 1/EJ dx = [1/4 x - 1/4 x^2/b + 1/12 x^3/b^2]_0^b 1/EJ$$

$$= (1/4 b - 1/4 b + 1/12 b) 1/EJ = 1/12 b/EJ$$

$$L_{AG}^{xx} = \int_0^b (1/4 x^2/b^2) 1/EJ dx = [1/12 x^3/b^2]_0^b 1/EJ$$

$$= (1/12 b) 1/EJ = 1/12 b/EJ$$

$$L_{FG}^{xo} = \int_0^b (7/8 x^2/b^2 - 1/4 x^3/b^3) Fb 1/EJ dx + \int_0^b (1/2 x/b) \theta dx$$

$$= [7/24 x^3/b^2 - 1/16 x^4/b^3]_0^b Fb 1/EJ + [1/4 x^2/b]_0^b \theta$$

$$= (7/24 b - 1/16 b) Fb 1/EJ + (1/4 b) \theta = 23/48 Fb^2/EJ$$

$$L_{GF}^{xo} = \int_0^b (5/8 - x/b + 1/8 x^2/b^2 + 1/4 x^3/b^3) Fb 1/EJ dx + \int_0^b (-1/2 + 1/2 x/b) \theta dx$$

$$= [5/8 x - 1/2 x^2/b + 1/24 x^3/b^2 + 1/16 x^4/b^3]_0^b Fb 1/EJ + [-1/2 x + 1/4 x^2/b]_0^b \theta$$

$$= (5/8 b - 1/2 b + 1/24 b + 1/16 b) Fb 1/EJ + (-1/2 b + 1/4 b) \theta = 23/48 Fb^2/EJ$$

$$L_{GD}^{xo} = \int_0^b (5/2 x/b - 5/2 x^2/b^2) Fb 1/EJ dx = [5/4 x^2/b - 5/6 x^3/b^2]_0^b Fb 1/EJ$$

$$= (5/4 b - 5/6 b) Fb 1/EJ = 5/12 Fb^2/EJ$$

$$L_{DG}^{xo} = \int_0^b (5/2 x/b - 5/2 x^2/b^2) Fb 1/EJ dx = [5/4 x^2/b - 5/6 x^3/b^2]_0^b Fb 1/EJ$$

$$= (5/4 b - 5/6 b) Fb 1/EJ = 5/12 Fb^2/EJ$$

$$L_{GA}^{xo} = \int_0^b (-5/8 + 5/4 x/b - 5/8 x^2/b^2) Fb 1/EJ dx = [-5/8 x + 5/8 x^2/b - 5/24 x^3/b^2]_0^b Fb 1/EJ$$

$$= (-5/8 b + 5/8 b - 5/24 b) Fb 1/EJ = -5/24 Fb^2/EJ$$

$$L_{AG}^{xo} = \int_0^b (-5/8 x^2/b^2) Fb 1/EJ dx = [-5/24 x^3/b^2]_0^b Fb 1/EJ$$

$$= (-5/24 b) Fb 1/EJ = -5/24 Fb^2/EJ$$

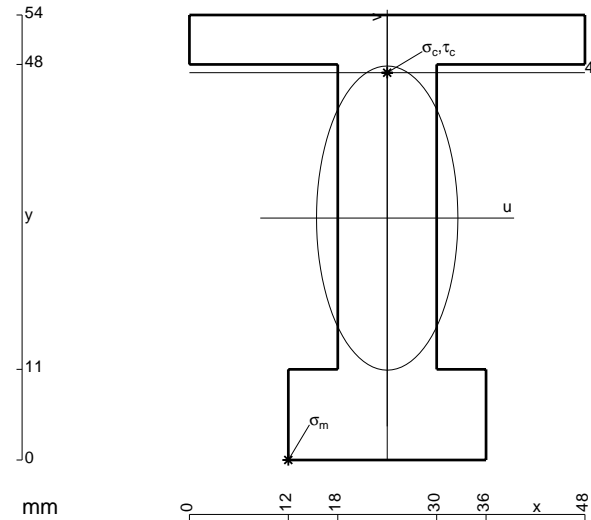

- A = 996. mm²
- J_u = 339350. mm⁴
- J_v = 73296. mm⁴
- y_g = 29.36 mm
- T_y = -4320. N
- M_x = -2419200. Nmm
- x_m = 12. mm
- u_m = -12. mm
- v_m = -29.36 mm
- σ_m = -Mv/J_u = -209.3 N/mm²
- x_c = 24. mm
- y_c = 47. mm
- v_c = 17.64 mm
- σ_c = -Mv/J_u = 125.8 N/mm²
- τ_c = 6.844 N/mm²
- σ_q = √σ²+3τ² = 126.3 N/mm²
- S = 6451. mm³

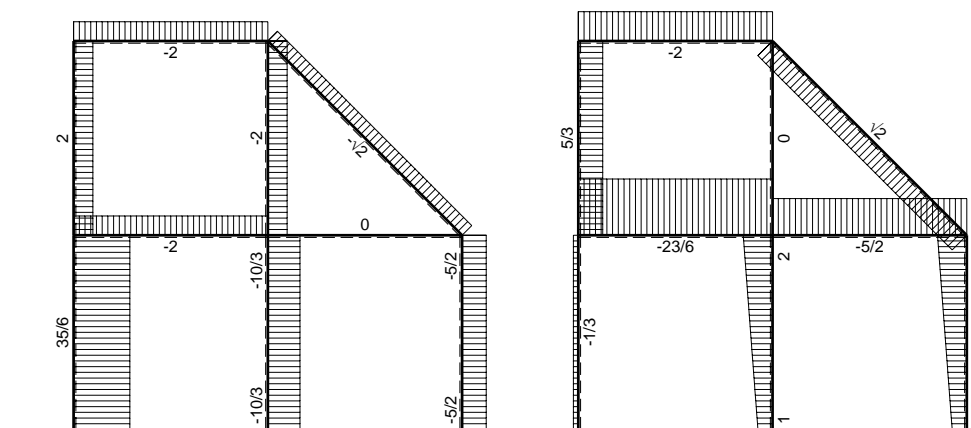
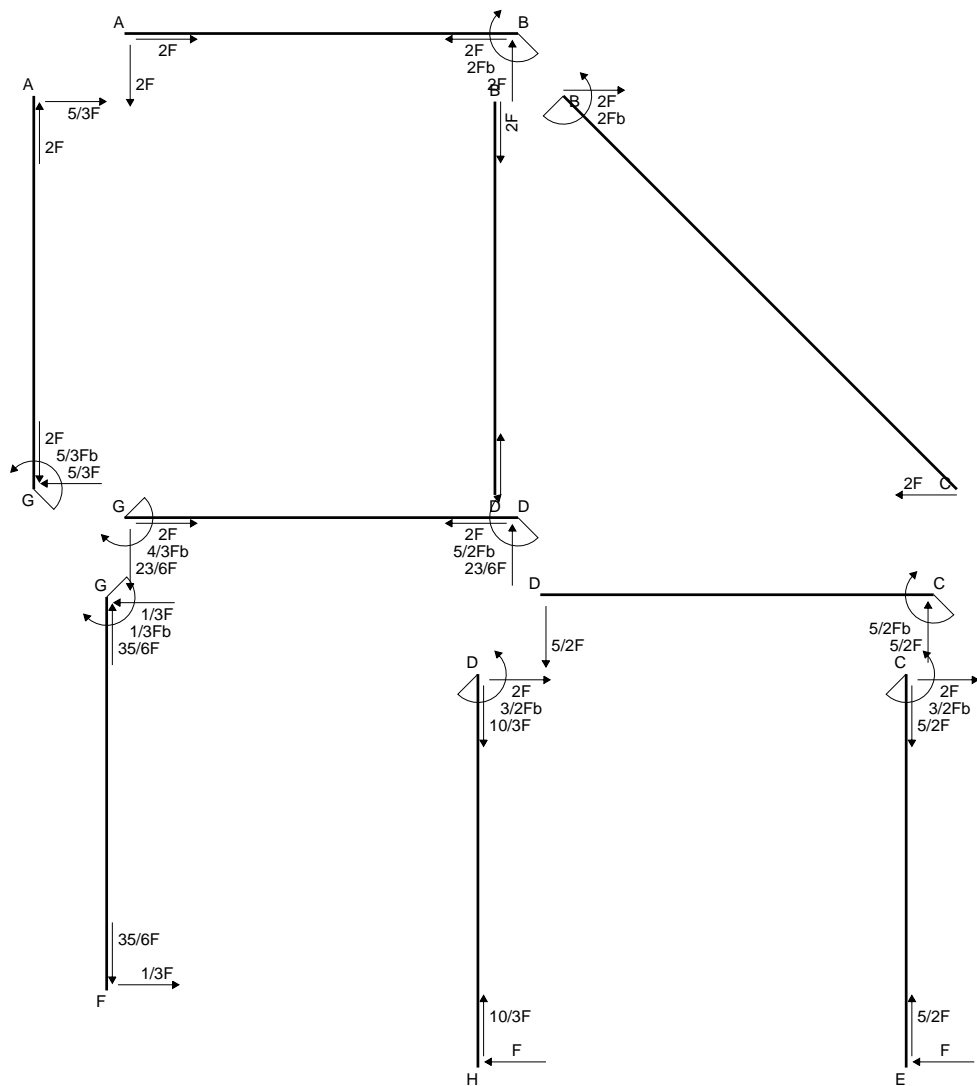

← ⊕ → F

↑ ⊕ ↓ Fb

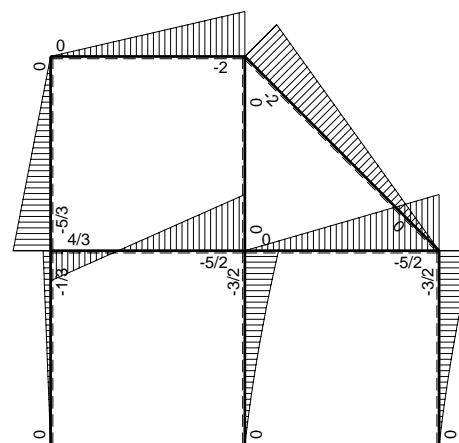

⊕ Fb

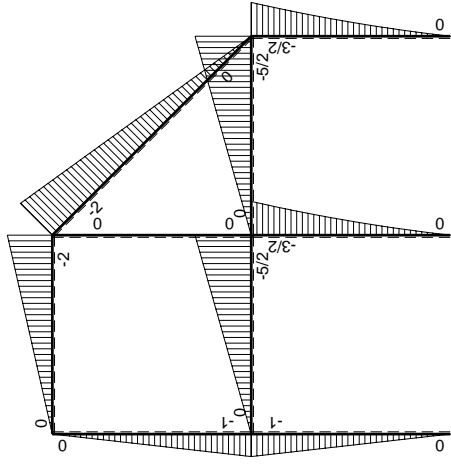
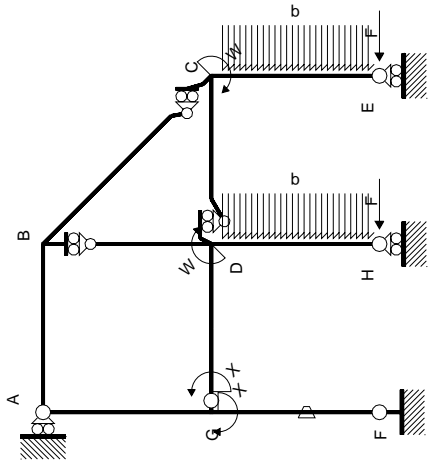

Schema di calcolo iperstatico

M_0 , flessione da carichi assegnati

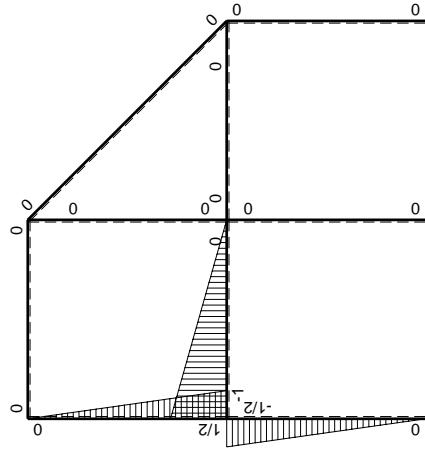

M_1 , flessione da iperstatica $X=1$

Quadro contributi PLV per iperstatica $X=W_{GD}$

→	$M_x(x)$	$M_o(x)$	θ	$M_x M_o$	$M_x \theta$	$M_x M_x$	$\int M_x(M_o/EJ+\theta)dx$	$\int X M_x M_x / EJ dx$	
AB b	0	-2Fx	0	0	0	0	0+0	0	
BA b	0	2Fb-2Fx	0	0	0	0	0	0	
BC $\sqrt{2}b$	0	-2Fb+ $\sqrt{2}Fx$	0	0	0	0	0	0	
BD b	0	0	0	0	0	0	0+0	0	
DB b	0	0	0	0	0	0	0	0	
DC b	0	-5/2Fx	0	0	0	0	0+0	0	
CD b	0	5/2Fb-5/2Fx	0	0	0	0	0	0	
CE b	0	-3/2Fb+2Fx-1/2qx ²	0	0	0	0	0+0	0	
EC b	0	Fx+1/2qx ²	0	0	0	0	0	0	
FG b	-1/2x/b	-Fx	-Fb/EJ	1/2Fx ² /b	1/2Fx/EJ	1/4x ² /b ²	(1/6+1/4)Fb ² /EJ	1/12Xb/EJ	
GF b	1/2-1/2x/b	Fb-Fx	Fb/EJ	1/2Fb-Fx+1/2Fx ² /b	1/2Fb/EJ-1/2Fx/EJ	1/4-1/2x/b+1/4x ² /b ²			
GD b	-1+x/b	-5/2Fx	0	5/2Fx-5/2Fx ² /b	0	1-2x/b+x ² /b ²	(5/12+0)Fb ² /EJ	1/3Xb/EJ	
DG b	x/b	5/2Fb-5/2Fx	0	5/2Fx-5/2Fx ² /b	0	x ² /b ²			
DH b	0	-3/2Fb+2Fx-1/2qx ²	0	0	0	0	0+0	0	
HD b	0	Fx+1/2qx ²	0	0	0	0	0	0	
GA b	1/2-1/2x/b	-Fb+Fx	0	-1/2Fb+Fx-1/2Fx ² /b	0	1/4-1/2x/b+1/4x ² /b ²	(-1/6+0)Fb ² /EJ	1/12Xb/EJ	
AG b	-1/2x/b	Fx	0	-1/2Fx ² /b	0	1/4x ² /b ²			
	totali							2/3Fb ² /EJ	1/2Xb/EJ
	iperstatica $X=W_{GD}$							-4/3Fb	

Sviluppi di calcolo iperstatica

$$L_{FG}^{xx} = \int_0^b (1/4 x^2/b^2) 1/EJ dx = [1/12 x^3/b^2]_0^b 1/EJ$$

$$= (1/12 b) 1/EJ = 1/12 b/EJ$$

$$L_{GF}^{xx} = \int_0^b (1/4 - 1/2 x/b + 1/4 x^2/b^2) 1/EJ dx = [1/4 x - 1/4 x^2/b + 1/12 x^3/b^2]_0^b 1/EJ$$

$$= (1/4 b - 1/4 b + 1/12 b) 1/EJ = 1/12 b/EJ$$

$$L_{GD}^{xx} = \int_0^b (1 - 2 x/b + x^2/b^2) 1/EJ dx = [x - x^2/b + 1/3 x^3/b^2]_0^b 1/EJ$$

$$= (b - b + 1/3 b) 1/EJ = 1/3 b/EJ$$

$$L_{DG}^{xx} = \int_0^b (x^2/b^2) 1/EJ dx = [1/3 x^3/b^2]_0^b 1/EJ$$

$$= (1/3 b) 1/EJ = 1/3 b/EJ$$

$$L_{GA}^{xx} = \int_0^b (1/4 - 1/2 x/b + 1/4 x^2/b^2) 1/EJ dx = [1/4 x - 1/4 x^2/b + 1/12 x^3/b^2]_0^b 1/EJ$$

$$= (1/4 b - 1/4 b + 1/12 b) 1/EJ = 1/12 b/EJ$$

$$L_{AG}^{xx} = \int_0^b (1/4 x^2/b^2) 1/EJ dx = [1/12 x^3/b^2]_0^b 1/EJ$$

$$= (1/12 b) 1/EJ = 1/12 b/EJ$$

$$L_{FG}^{xo} = \int_0^b (1/2 x^2/b^2) Fb 1/EJ dx + \int_0^b (1/2 x/b) \theta dx = [1/6 x^3/b^2]_0^b Fb 1/EJ + [1/4 x^2/b]_0^b \theta$$

$$= (1/6 b) Fb 1/EJ + (1/4 b) \theta = 5/12 Fb^2/EJ$$

$$L_{GF}^{xo} = \int_0^b (1/2 - x/b + 1/2 x^2/b^2) Fb 1/EJ dx + \int_0^b (-1/2 + 1/2 x/b) \theta dx$$

$$= [1/2 x - 1/2 x^2/b + 1/6 x^3/b^2]_0^b Fb 1/EJ + [-1/2 x + 1/4 x^2/b]_0^b \theta$$

$$= (1/2 b - 1/2 b + 1/6 b) Fb 1/EJ + (-1/2 b + 1/4 b) \theta = 5/12 Fb^2/EJ$$

$$L_{GD}^{xo} = \int_0^b (5/2 x/b - 5/2 x^2/b^2) Fb 1/EJ dx = [5/4 x^2/b - 5/6 x^3/b^2]_0^b Fb 1/EJ$$

$$= (5/4 b - 5/6 b) Fb 1/EJ = 5/12 Fb^2/EJ$$

$$L_{DG}^{xo} = \int_0^b (5/2 x/b - 5/2 x^2/b^2) Fb 1/EJ dx = [5/4 x^2/b - 5/6 x^3/b^2]_0^b Fb 1/EJ$$

$$= (5/4 b - 5/6 b) Fb 1/EJ = 5/12 Fb^2/EJ$$

$$L_{GA}^{xo} = \int_0^b (-1/2 + x/b - 1/2 x^2/b^2) Fb 1/EJ dx = [-1/2 x + 1/2 x^2/b - 1/6 x^3/b^2]_0^b Fb 1/EJ$$

$$= (-1/2 b + 1/2 b - 1/6 b) Fb 1/EJ = -1/6 Fb^2/EJ$$

$$L_{AG}^{xo} = \int_0^b (-1/2 x^2/b^2) Fb 1/EJ dx = [-1/6 x^3/b^2]_0^b Fb 1/EJ$$

$$= (-1/6 b) Fb 1/EJ = -1/6 Fb^2/EJ$$

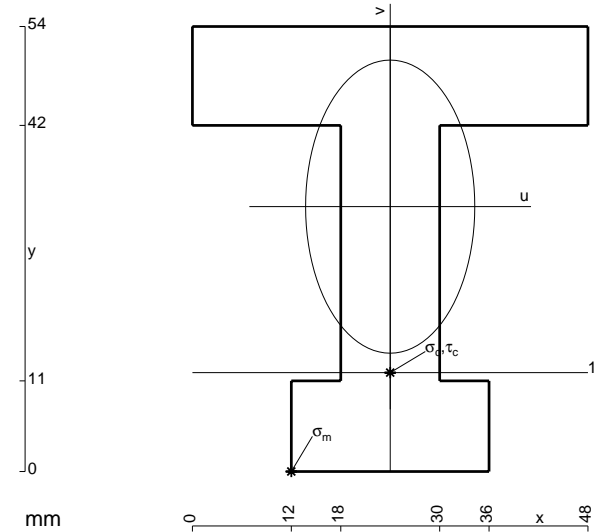

$$A = 1212. \text{ mm}^2$$

$$J_u = 383443. \text{ mm}^4$$

$$J_v = 127728. \text{ mm}^4$$

$$y_g = 32.14 \text{ mm}$$

$$T_y = -4300. \text{ N}$$

$$M_x = -2623000. \text{ Nmm}$$

$$x_m = 12. \text{ mm}$$

$$u_m = -12. \text{ mm}$$

$$v_m = -32.14 \text{ mm}$$

$$\sigma_m = -Mv/J_u = -219.9 \text{ N/mm}^2$$

$$x_c = 24. \text{ mm}$$

$$y_c = 12. \text{ mm}$$

$$v_c = -20.14 \text{ mm}$$

$$\sigma_c = -Mv/J_u = -137.8 \text{ N/mm}^2$$

$$\tau_c = 6.805 \text{ N/mm}^2$$

$$\sigma_o = \sqrt{\sigma^2 + 3\tau^2} = 138.3 \text{ N/mm}^2$$

$$S = 7282. \text{ mm}^3$$

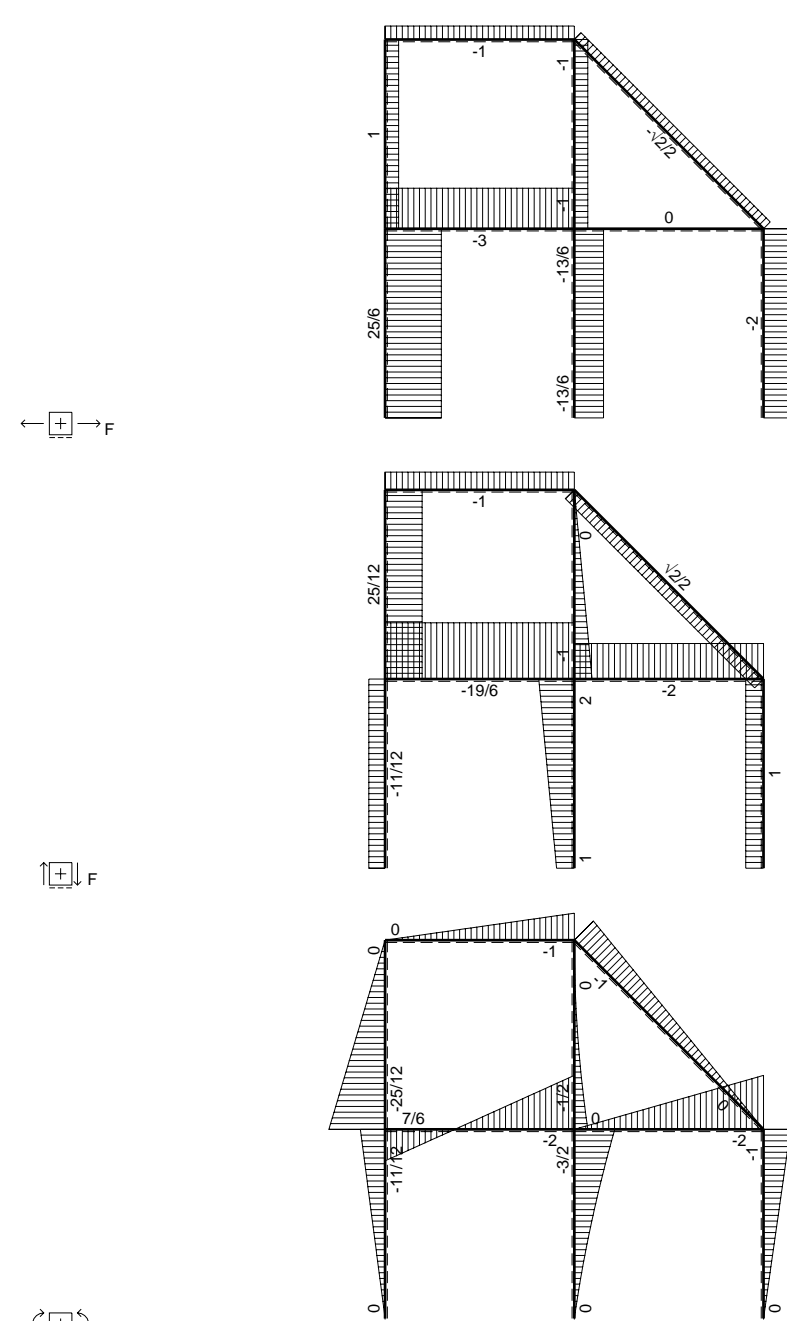
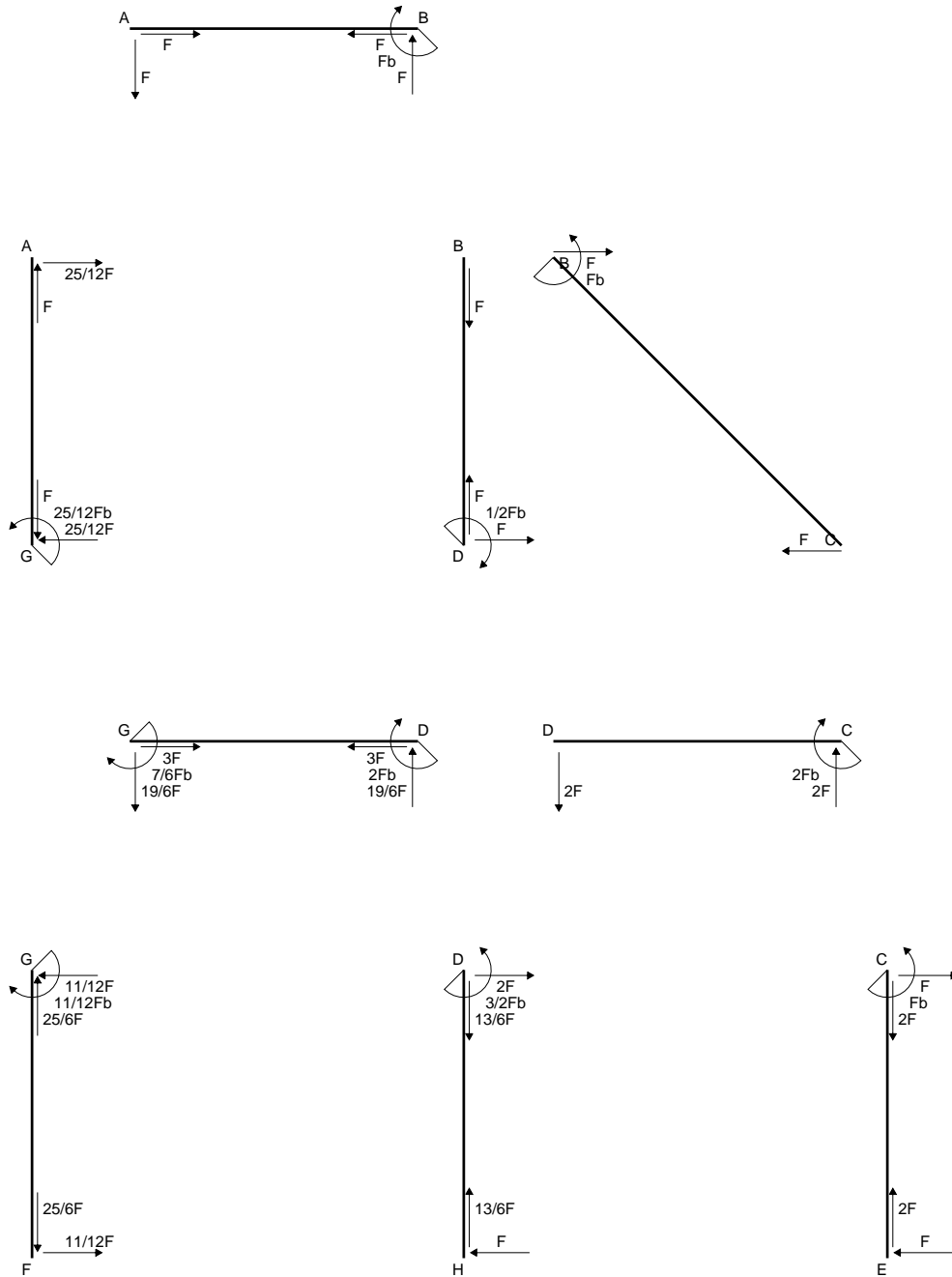

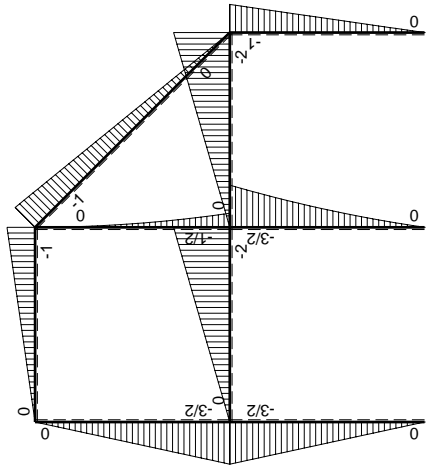
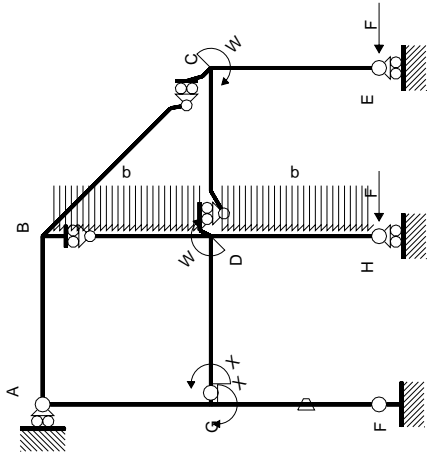

Schema di calcolo iperstatico

M_0 flessione da carichi assegnati

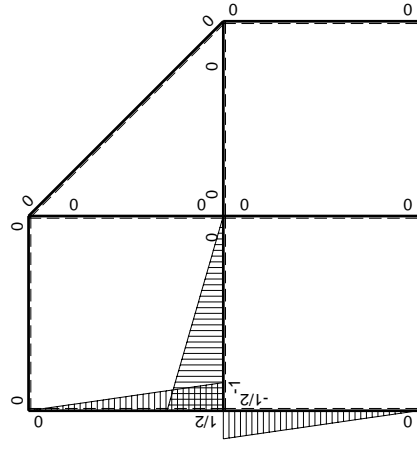

M_x flessione da iperstatica $X=1$

Quadro contributi PLV per iperstatica $X=W_{GD}$

→	$M_x(x)$	$M_o(x)$	θ	$M_x M_o$	$M_x \theta$	$M_x M_x$	$\int M_x(M_o/EJ+\theta)dx$	$\int X M_x M_x/EJdx$	
AB b	0	-Fx	0	0	0	0	0+0	0	
BA b	0	Fb-Fx	0	0	0	0			
BC $\sqrt{2}b$	0	-Fb+ $\sqrt{2}/2Fx$	0	0	0	0	0	0	
BD b	0	-1/2qx ²	0	0	0	0	0+0	0	
DB b	0	1/2Fb-Fx+1/2qx ²	0	0	0	0			
DC b	0	-2Fx	0	0	0	0	0+0	0	
CD b	0	2Fb-2Fx	0	0	0	0			
CE b	0	-Fb+Fx	0	0	0	0	0+0	0	
EC b	0	Fx	0	0	0	0			
FG b	-1/2x/b	-3/2Fx	-Fb/EJ	3/4Fx ² /b	1/2Fx/EJ	1/4x ² /b ²	(1/4+1/4)Fb ² /EJ	1/12Xb/EJ	
GF b	1/2-1/2x/b	3/2Fb-3/2Fx	Fb/EJ	3/4Fb-3/2Fx+3/4Fx ² /b	1/2Fb/EJ-1/2Fx/EJ	1/4-1/2x/b+1/4x ² /b ²			
GD b	-1+x/b	-2Fx	0	2Fx-2Fx ² /b	0	1-2x/b+x ² /b ²	(1/3+0)Fb ² /EJ	1/3Xb/EJ	
DG b	x/b	2Fb-2Fx	0	2Fx-2Fx ² /b	0	x ² /b ²			
DH b	0	-3/2Fb+2Fx-1/2qx ²	0	0	0	0	0+0	0	
HD b	0	Fx+1/2qx ²	0	0	0	0			
GA b	1/2-1/2x/b	-3/2Fb+3/2Fx	0	-3/4Fb+3/2Fx-3/4Fx ² /b	0	1/4-1/2x/b+1/4x ² /b ²	(-1/4+0)Fb ² /EJ	1/12Xb/EJ	
AG b	-1/2x/b	3/2Fx	0	-3/4Fx ² /b	0	1/4x ² /b ²			
	totali							7/12Fb ² /EJ	1/2Xb/EJ
	iperstatica $X=W_{GD}$							-7/6Fb	

Sviluppi di calcolo iperstatica

$$L_{FG}^{xx} = \int_0^b (1/4 x^2/b^2) 1/EJ dx = [1/12 x^3/b^2]_0^b 1/EJ$$

$$= (1/12 b) 1/EJ = 1/12 b/EJ$$

$$L_{GF}^{xx} = \int_0^b (1/4 - 1/2 x/b + 1/4 x^2/b^2) 1/EJ dx = [1/4 x - 1/4 x^2/b + 1/12 x^3/b^2]_0^b 1/EJ$$

$$= (1/4 b - 1/4 b + 1/12 b) 1/EJ = 1/12 b/EJ$$

$$L_{GD}^{xx} = \int_0^b (1 - 2 x/b + x^2/b^2) 1/EJ dx = [x - x^2/b + 1/3 x^3/b^2]_0^b 1/EJ$$

$$= (b - b + 1/3 b) 1/EJ = 1/3 b/EJ$$

$$L_{DG}^{xx} = \int_0^b (x^2/b^2) 1/EJ dx = [1/3 x^3/b^2]_0^b 1/EJ$$

$$= (1/3 b) 1/EJ = 1/3 b/EJ$$

$$L_{GA}^{xx} = \int_0^b (1/4 - 1/2 x/b + 1/4 x^2/b^2) 1/EJ dx = [1/4 x - 1/4 x^2/b + 1/12 x^3/b^2]_0^b 1/EJ$$

$$= (1/4 b - 1/4 b + 1/12 b) 1/EJ = 1/12 b/EJ$$

$$L_{AG}^{xx} = \int_0^b (1/4 x^2/b^2) 1/EJ dx = [1/12 x^3/b^2]_0^b 1/EJ$$

$$= (1/12 b) 1/EJ = 1/12 b/EJ$$

$$L_{FG}^{xo} = \int_0^b (3/4 x^2/b^2) Fb 1/EJ dx + \int_0^b (1/2 x/b) \theta dx = [1/4 x^3/b^2]_0^b Fb 1/EJ + [1/4 x^2/b]_0^b \theta$$

$$= (1/4 b) Fb 1/EJ + (1/4 b) \theta = 1/2 Fb^2/EJ$$

$$L_{GF}^{xo} = \int_0^b (3/4 - 3/2 x/b + 3/4 x^2/b^2) Fb 1/EJ dx + \int_0^b (-1/2 + 1/2 x/b) \theta dx$$

$$= [3/4 x - 3/4 x^2/b + 1/4 x^3/b^2]_0^b Fb 1/EJ + [-1/2 x + 1/4 x^2/b]_0^b \theta$$

$$= (3/4 b - 3/4 b + 1/4 b) Fb 1/EJ + (-1/2 b + 1/4 b) \theta = 1/2 Fb^2/EJ$$

$$L_{GD}^{xo} = \int_0^b (2 x/b - 2 x^2/b^2) Fb 1/EJ dx = [x^2/b - 2/3 x^3/b^2]_0^b Fb 1/EJ$$

$$= (b - 2/3 b) Fb 1/EJ = 1/3 Fb^2/EJ$$

$$L_{DG}^{xo} = \int_0^b (2 x/b - 2 x^2/b^2) Fb 1/EJ dx = [x^2/b - 2/3 x^3/b^2]_0^b Fb 1/EJ$$

$$= (b - 2/3 b) Fb 1/EJ = 1/3 Fb^2/EJ$$

$$L_{GA}^{xo} = \int_0^b (-3/4 + 3/2 x/b - 3/4 x^2/b^2) Fb 1/EJ dx = [-3/4 x + 3/4 x^2/b - 1/4 x^3/b^2]_0^b Fb 1/EJ$$

$$= (-3/4 b + 3/4 b - 1/4 b) Fb 1/EJ = -1/4 Fb^2/EJ$$

$$L_{AG}^{xo} = \int_0^b (-3/4 x^2/b^2) Fb 1/EJ dx = [-1/4 x^3/b^2]_0^b Fb 1/EJ$$

$$= (-1/4 b) Fb 1/EJ = -1/4 Fb^2/EJ$$

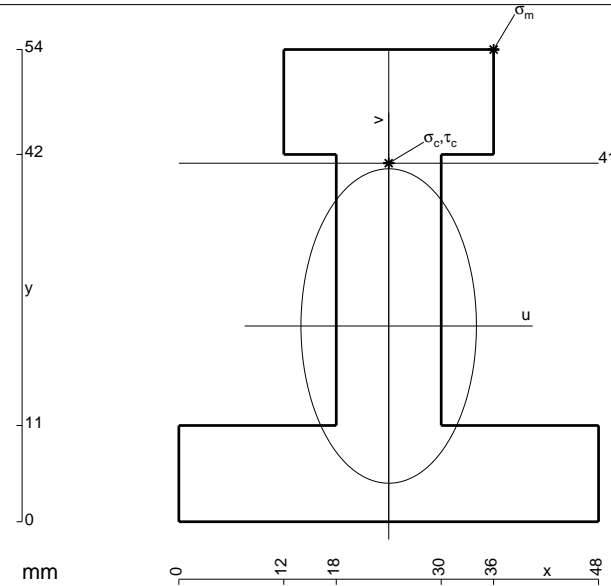

- A = 1188. mm²
- J_u = 384370. mm⁴
- J_v = 119664. mm⁴
- y_g = 22.38 mm
- T_y = -4220. N
- M_x = -2785200. Nmm
- x_m = 36. mm
- y_m = 54. mm
- u_m = 12. mm
- v_m = 31.62 mm
- σ_m = -Mv/J_u = 229.1 N/mm²
- x_c = 24. mm
- y_c = 41. mm
- v_c = 18.62 mm
- σ_c = -Mv/J_u = 134.9 N/mm²
- τ_c = 6.961 N/mm²
- σ_q = √σ²+3τ² = 135.5 N/mm²
- S = 7608. mm³

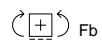
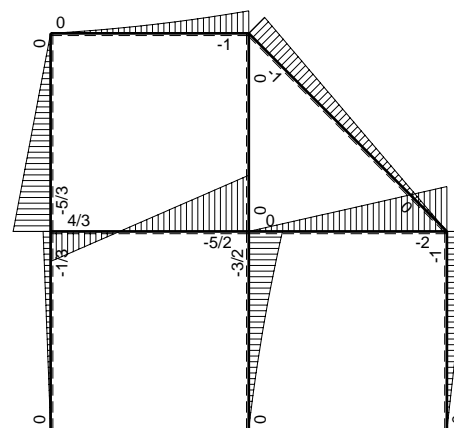
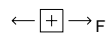
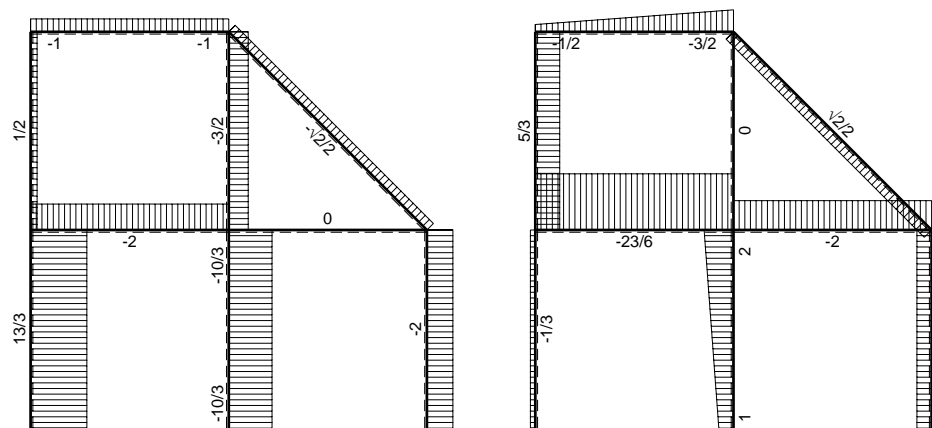
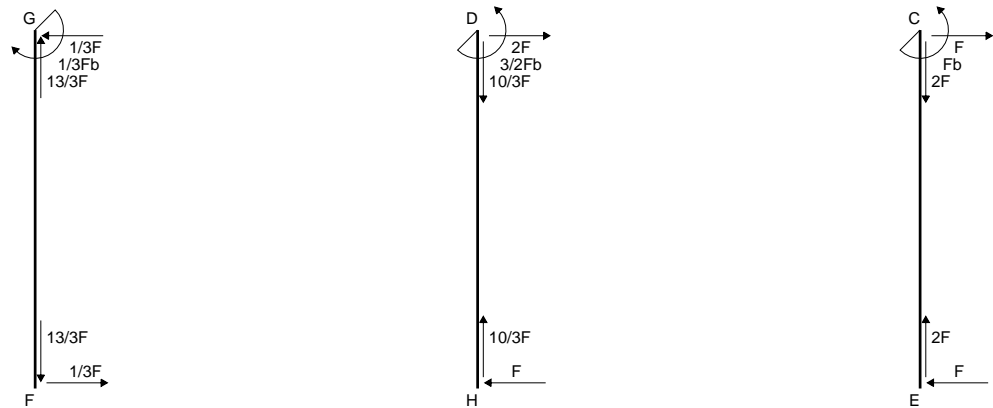
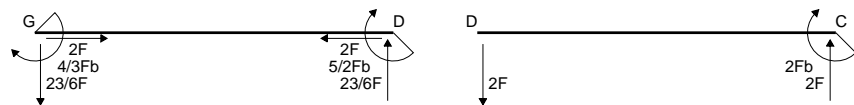
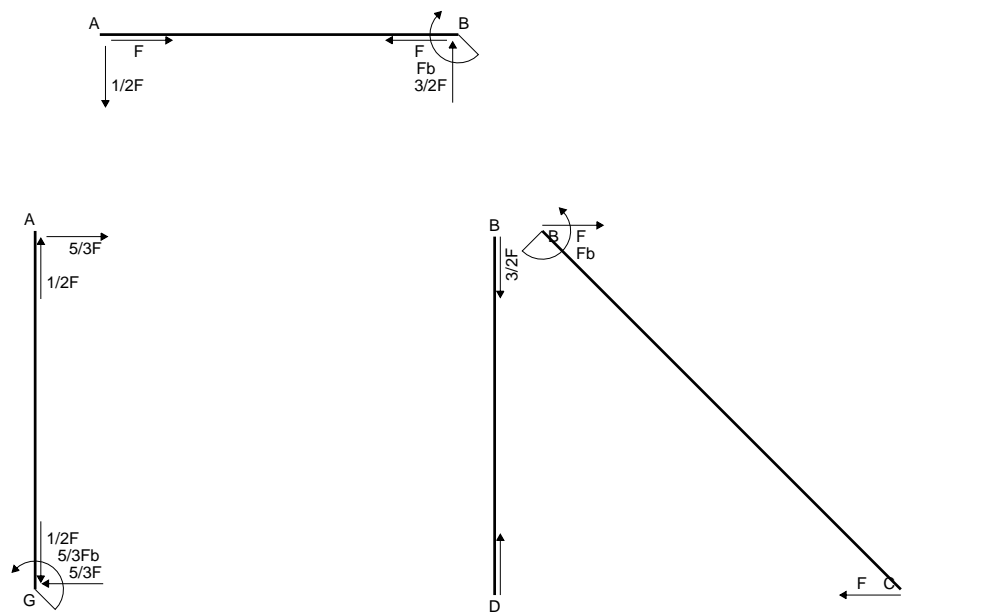

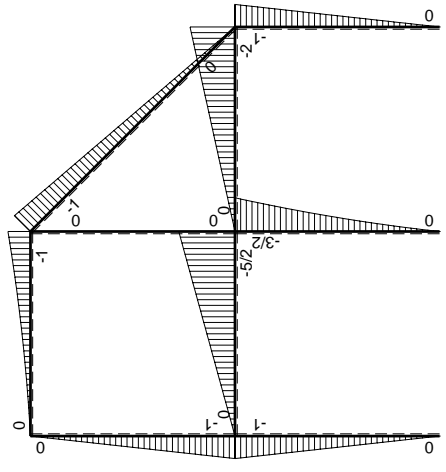
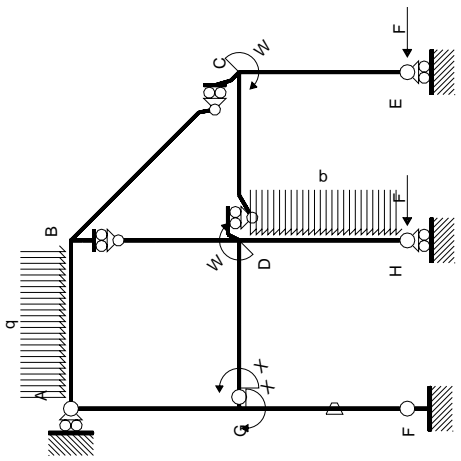

Schema di calcolo iperstatico

M_0 flessione da carichi assegnati

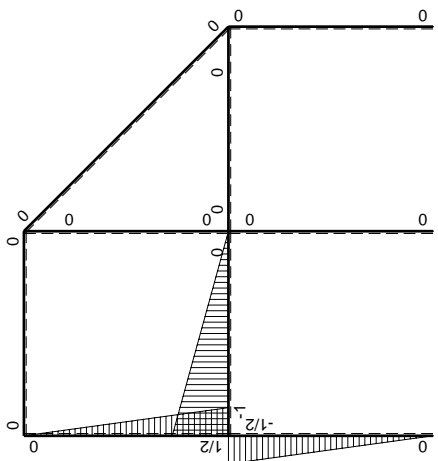

M_x flessione da iperstatica $X=1$

Quadro contributi PLV per iperstatica $X=W_{GD}$

→	$M_x(x)$	$M_o(x)$	θ	$M_x M_o$	$M_x \theta$	$M_x M_x$	$\int M_x(M_o/EJ+\theta)dx$	$\int X M_x M_x/EJ dx$
AB b	0	$-1/2Fx-1/2qx^2$	0	0	0	0	0+0	0
BA b	0	$Fb-3/2Fx+1/2qx^2$	0	0	0	0	0	0
BC $\sqrt{2}b$	0	$-Fb+\sqrt{2}/2Fx$	0	0	0	0	0	0
BD b	0	0	0	0	0	0	0+0	0
DB b	0	0	0	0	0	0	0	0
DC b	0	$-2Fx$	0	0	0	0	0+0	0
CD b	0	$2Fb-2Fx$	0	0	0	0	0	0
CE b	0	$-Fb+Fx$	0	0	0	0	0+0	0
EC b	0	Fx	0	0	0	0	0	0
FG b	$-1/2x/b$	$-Fx$	$-Fb/EJ$	$1/2Fx^2/b$	$1/2Fx/EJ$	$1/4x^2/b^2$	$(1/6+1/4)Fb^2/EJ$	$1/12Xb/EJ$
GF b	$1/2-1/2x/b$	$Fb-Fx$	Fb/EJ	$1/2Fb-Fx+1/2Fx^2/b$	$1/2Fb/EJ-1/2Fx/EJ$	$1/4-1/2x/b+1/4x^2/b^2$		
GD b	$-1+x/b$	$-5/2Fx$	0	$5/2Fx-5/2Fx^2/b$	0	$1-2x/b+x^2/b^2$	$(5/12+0)Fb^2/EJ$	$1/3Xb/EJ$
DG b	x/b	$5/2Fb-5/2Fx$	0	$5/2Fx-5/2Fx^2/b$	0	x^2/b^2		
DH b	0	$-3/2Fb+2Fx-1/2qx^2$	0	0	0	0	0+0	0
HD b	0	$Fx+1/2qx^2$	0	0	0	0	0	0
GA b	$1/2-1/2x/b$	$-Fb+Fx$	0	$-1/2Fb+Fx-1/2Fx^2/b$	0	$1/4-1/2x/b+1/4x^2/b^2$	$(-1/6+0)Fb^2/EJ$	$1/12Xb/EJ$
AG b	$-1/2x/b$	Fx	0	$-1/2Fx^2/b$	0	$1/4x^2/b^2$		
	totali						$2/3Fb^2/EJ$	$1/2Xb/EJ$
	iperstatica $X=W_{GD}$						$-4/3Fb$	

Sviluppi di calcolo iperstatica

$$L_{FG}^{xx} = \int_0^b (1/4 x^2/b^2) 1/EJ dx = [1/12 x^3/b^2]_0^b 1/EJ$$

$$= (1/12 b) 1/EJ = 1/12 b/EJ$$

$$L_{GF}^{xx} = \int_0^b (1/4 - 1/2 x/b + 1/4 x^2/b^2) 1/EJ dx = [1/4 x - 1/4 x^2/b + 1/12 x^3/b^2]_0^b 1/EJ$$

$$= (1/4 b - 1/4 b + 1/12 b) 1/EJ = 1/12 b/EJ$$

$$L_{GD}^{xx} = \int_0^b (1 - 2 x/b + x^2/b^2) 1/EJ dx = [x - x^2/b + 1/3 x^3/b^2]_0^b 1/EJ$$

$$= (b - b + 1/3 b) 1/EJ = 1/3 b/EJ$$

$$L_{DG}^{xx} = \int_0^b (x^2/b^2) 1/EJ dx = [1/3 x^3/b^2]_0^b 1/EJ$$

$$= (1/3 b) 1/EJ = 1/3 b/EJ$$

$$L_{GA}^{xx} = \int_0^b (1/4 - 1/2 x/b + 1/4 x^2/b^2) 1/EJ dx = [1/4 x - 1/4 x^2/b + 1/12 x^3/b^2]_0^b 1/EJ$$

$$= (1/4 b - 1/4 b + 1/12 b) 1/EJ = 1/12 b/EJ$$

$$L_{AG}^{xx} = \int_0^b (1/4 x^2/b^2) 1/EJ dx = [1/12 x^3/b^2]_0^b 1/EJ$$

$$= (1/12 b) 1/EJ = 1/12 b/EJ$$

$$L_{FG}^{xo} = \int_0^b (1/2 x^2/b^2) Fb 1/EJ dx + \int_0^b (1/2 x/b) \theta dx = [1/6 x^3/b^2]_0^b Fb 1/EJ + [1/4 x^2/b]_0^b \theta$$

$$= (1/6 b) Fb 1/EJ + (1/4 b) \theta = 5/12 Fb^2/EJ$$

$$L_{GF}^{xo} = \int_0^b (1/2 - x/b + 1/2 x^2/b^2) Fb 1/EJ dx + \int_0^b (-1/2 + 1/2 x/b) \theta dx$$

$$= [1/2 x - 1/2 x^2/b + 1/6 x^3/b^2]_0^b Fb 1/EJ + [-1/2 x + 1/4 x^2/b]_0^b \theta$$

$$= (1/2 b - 1/2 b + 1/6 b) Fb 1/EJ + (-1/2 b + 1/4 b) \theta = 5/12 Fb^2/EJ$$

$$L_{GD}^{xo} = \int_0^b (5/2 x/b - 5/2 x^2/b^2) Fb 1/EJ dx = [5/4 x^2/b - 5/6 x^3/b^2]_0^b Fb 1/EJ$$

$$= (5/4 b - 5/6 b) Fb 1/EJ = 5/12 Fb^2/EJ$$

$$L_{DG}^{xo} = \int_0^b (5/2 x/b - 5/2 x^2/b^2) Fb 1/EJ dx = [5/4 x^2/b - 5/6 x^3/b^2]_0^b Fb 1/EJ$$

$$= (5/4 b - 5/6 b) Fb 1/EJ = 5/12 Fb^2/EJ$$

$$L_{GA}^{xo} = \int_0^b (-1/2 + x/b - 1/2 x^2/b^2) Fb 1/EJ dx = [-1/2 x + 1/2 x^2/b - 1/6 x^3/b^2]_0^b Fb 1/EJ$$

$$= (-1/2 b + 1/2 b - 1/6 b) Fb 1/EJ = -1/6 Fb^2/EJ$$

$$L_{AG}^{xo} = \int_0^b (-1/2 x^2/b^2) Fb 1/EJ dx = [-1/6 x^3/b^2]_0^b Fb 1/EJ$$

$$= (-1/6 b) Fb 1/EJ = -1/6 Fb^2/EJ$$

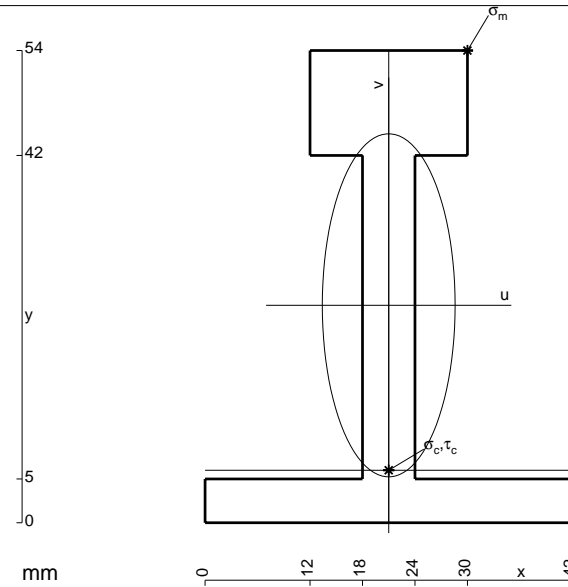

- A = 648. mm²
- J_u = 249420. mm⁴
- J_v = 37368. mm⁴
- y_g = 24.86 mm
- T_y = -2880. N
- M_x = -2044800. Nmm
- x_m = 30. mm
- y_m = 54. mm
- u_m = 9. mm
- v_m = 29.14 mm
- σ_m = -Mv/J_u = 238.9 N/mm²
- x_c = 21. mm
- y_c = 6. mm
- v_c = -18.86 mm
- σ_c = -Mv/J_u = -154.6 N/mm²
- τ_c = 9.261 N/mm²
- σ_q = √σ²+3τ² = 155.5 N/mm²
- S = 4812. mm³

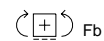
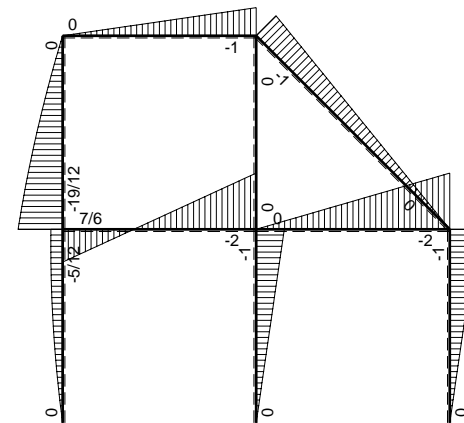
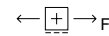
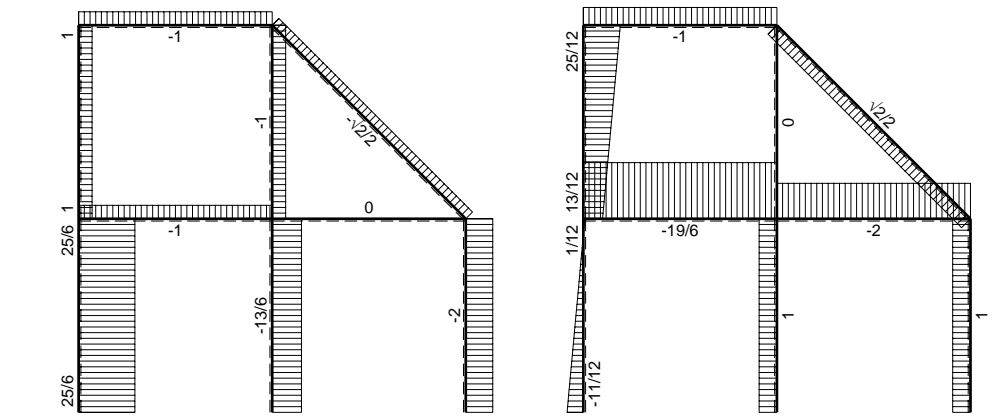
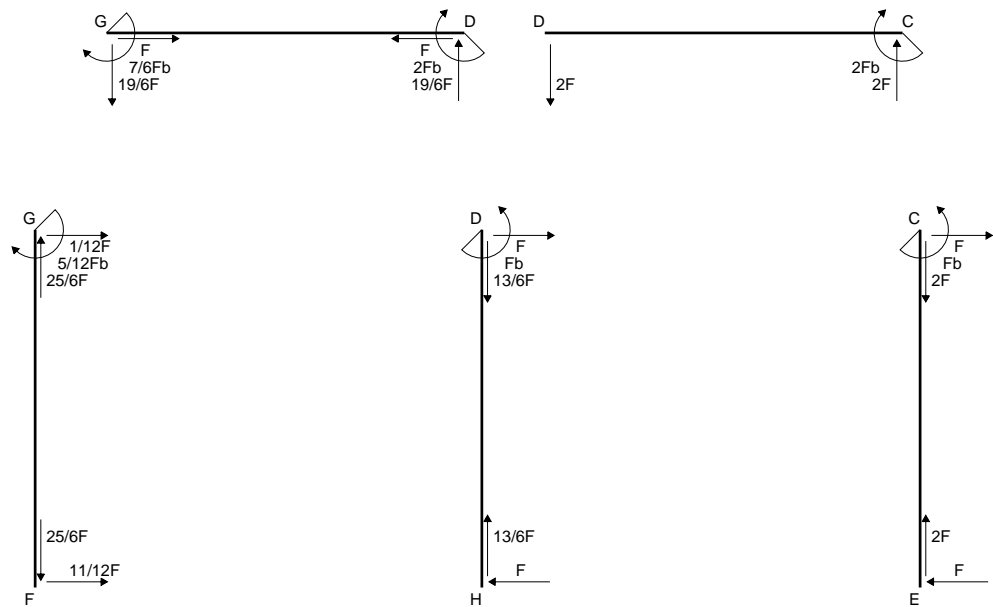
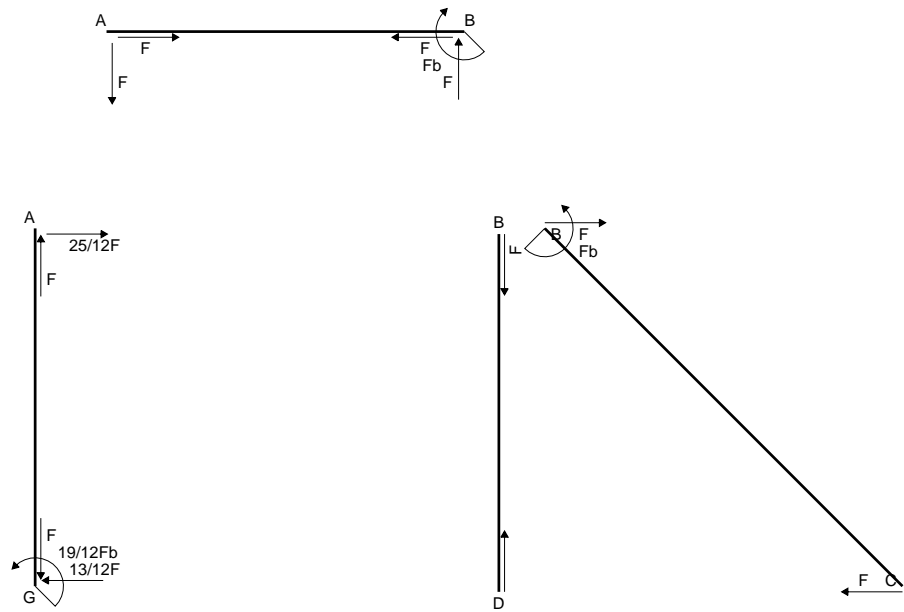

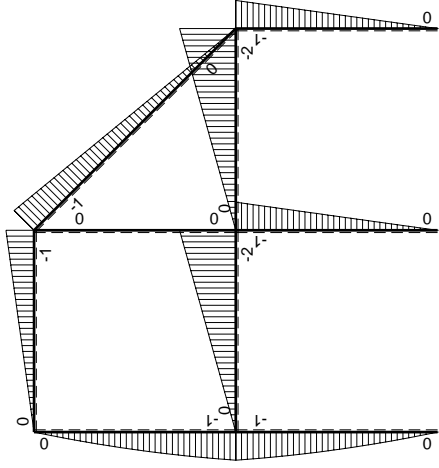
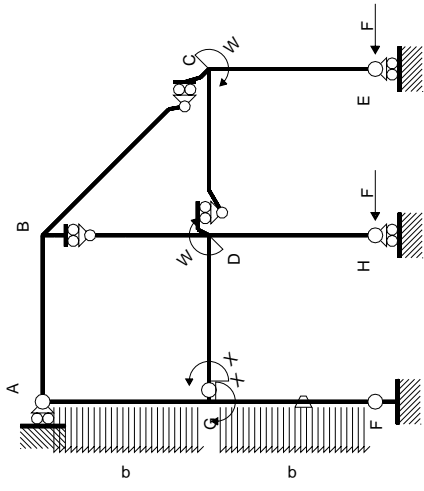

Schema di calcolo iperstatico

M_0 flessione da carichi assegnati

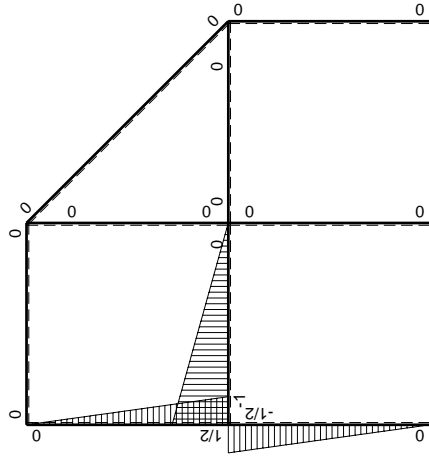

M_x flessione da iperstatica $X=1$

Quadro contributi PLV per iperstatica $X=W_{GD}$

→	$M_x(x)$	$M_o(x)$	θ	$M_x M_o$	$M_x \theta$	$M_x M_x$	$\int M_x(M_o/EJ+\theta)dx$	$\int X M_x M_x / EJ dx$
AB b	0	-Fx	0	0	0	0	0+0	0
BA b	0	Fb-Fx	0	0	0	0		
BC $\sqrt{2}b$	0	-Fb+ $\sqrt{2}/2Fx$	0	0	0	0	0	0
BD b	0	0	0	0	0	0	0+0	0
DB b	0	0	0	0	0	0		
DC b	0	-2Fx	0	0	0	0	0+0	0
CD b	0	2Fb-2Fx	0	0	0	0		
CE b	0	-Fb+Fx	0	0	0	0	0+0	0
EC b	0	Fx	0	0	0	0		
FG b	-1/2x/b	-3/2Fx+1/2qx ²	-Fb/EJ	3/4Fx ² /b-1/4qx ³ /b	1/2Fx/EJ	1/4x ² /b ²	(3/16+1/4)Fb ² /EJ	1/12Xb/EJ
GF b	1/2-1/2x/b	Fb-1/2Fx-1/2qx ²	Fb/EJ	1/2Fb-3/4Fx+1/4qx ³ /b	1/2Fb/EJ-1/2Fx/EJ	1/4-1/2x/b+1/4x ² /b ²		
GD b	-1+x/b	-2Fx	0	2Fx-2Fx ² /b	0	1-2x/b+x ² /b ²	(1/3+0)Fb ² /EJ	1/3Xb/EJ
DG b	x/b	2Fb-2Fx	0	2Fx-2Fx ² /b	0	x ² /b ²		
DH b	0	-Fb+Fx	0	0	0	0	0+0	0
HD b	0	Fx	0	0	0	0		
GA b	1/2-1/2x/b	-Fb+1/2Fx+1/2qx ²	0	-1/2Fb+3/4Fx-1/4qx ³ /b	0	1/4-1/2x/b+1/4x ² /b ²	(-3/16+0)Fb ² /EJ	1/12Xb/EJ
AG b	-1/2x/b	3/2Fx-1/2qx ²	0	-3/4Fx ² /b+1/4qx ³ /b	0	1/4x ² /b ²		
	totali						7/12Fb ² /EJ	1/2Xb/EJ
	iperstatica $X=W_{GD}$						-7/6Fb	

Sviluppi di calcolo iperstatica

$$L_{FG}^{xx} = \int_0^b (1/4 x^2/b^2) 1/EJ dx = [1/12 x^3/b^2]_0^b 1/EJ$$

$$= (1/12 b) 1/EJ = 1/12 b/EJ$$

$$L_{GF}^{xx} = \int_0^b (1/4 - 1/2 x/b + 1/4 x^2/b^2) 1/EJ dx = [1/4 x - 1/4 x^2/b + 1/12 x^3/b^2]_0^b 1/EJ$$

$$= (1/4 b - 1/4 b + 1/12 b) 1/EJ = 1/12 b/EJ$$

$$L_{GD}^{xx} = \int_0^b (1 - 2 x/b + x^2/b^2) 1/EJ dx = [x - x^2/b + 1/3 x^3/b^2]_0^b 1/EJ$$

$$= (b - b + 1/3 b) 1/EJ = 1/3 b/EJ$$

$$L_{DG}^{xx} = \int_0^b (x^2/b^2) 1/EJ dx = [1/3 x^3/b^2]_0^b 1/EJ$$

$$= (1/3 b) 1/EJ = 1/3 b/EJ$$

$$L_{GA}^{xx} = \int_0^b (1/4 - 1/2 x/b + 1/4 x^2/b^2) 1/EJ dx = [1/4 x - 1/4 x^2/b + 1/12 x^3/b^2]_0^b 1/EJ$$

$$= (1/4 b - 1/4 b + 1/12 b) 1/EJ = 1/12 b/EJ$$

$$L_{AG}^{xx} = \int_0^b (1/4 x^2/b^2) 1/EJ dx = [1/12 x^3/b^2]_0^b 1/EJ$$

$$= (1/12 b) 1/EJ = 1/12 b/EJ$$

$$L_{FG}^{xo} = \int_0^b (3/4 x^2/b^2 - 1/4 x^3/b^3) Fb 1/EJ dx + \int_0^b (1/2 x/b) \theta dx$$

$$= [1/4 x^3/b^2 - 1/16 x^4/b^3]_0^b Fb 1/EJ + [1/4 x^2/b]_0^b \theta$$

$$= (1/4 b - 1/16 b) Fb 1/EJ + (1/4 b) \theta = 7/16 Fb^2/EJ$$

$$L_{GF}^{xo} = \int_0^b (1/2 - 3/4 x/b + 1/4 x^2/b^2) Fb 1/EJ dx + \int_0^b (-1/2 + 1/2 x/b) \theta dx$$

$$= [1/2 x - 3/8 x^2/b + 1/16 x^3/b^2]_0^b Fb 1/EJ + [-1/2 x + 1/4 x^2/b]_0^b \theta$$

$$= (1/2 b - 3/8 b + 1/16 b) Fb 1/EJ + (-1/2 b + 1/4 b) \theta = 7/16 Fb^2/EJ$$

$$L_{GD}^{xo} = \int_0^b (2 x/b - 2 x^2/b^2) Fb 1/EJ dx = [x^2/b - 2/3 x^3/b^2]_0^b Fb 1/EJ$$

$$= (b - 2/3 b) Fb 1/EJ = 1/3 Fb^2/EJ$$

$$L_{DG}^{xo} = \int_0^b (2 x/b - 2 x^2/b^2) Fb 1/EJ dx = [x^2/b - 2/3 x^3/b^2]_0^b Fb 1/EJ$$

$$= (b - 2/3 b) Fb 1/EJ = 1/3 Fb^2/EJ$$

$$L_{GA}^{xo} = \int_0^b (-1/2 + 3/4 x/b - 1/4 x^2/b^2) Fb 1/EJ dx = [-1/2 x + 3/8 x^2/b - 1/16 x^3/b^2]_0^b Fb 1/EJ$$

$$= (-1/2 b + 3/8 b - 1/16 b) Fb 1/EJ = -3/16 Fb^2/EJ$$

$$L_{AG}^{xo} = \int_0^b (-3/4 x^2/b^2 + 1/4 x^3/b^3) Fb 1/EJ dx = [-1/4 x^3/b^2 + 1/16 x^4/b^3]_0^b Fb 1/EJ$$

$$= (-1/4 b + 1/16 b) Fb 1/EJ = -3/16 Fb^2/EJ$$

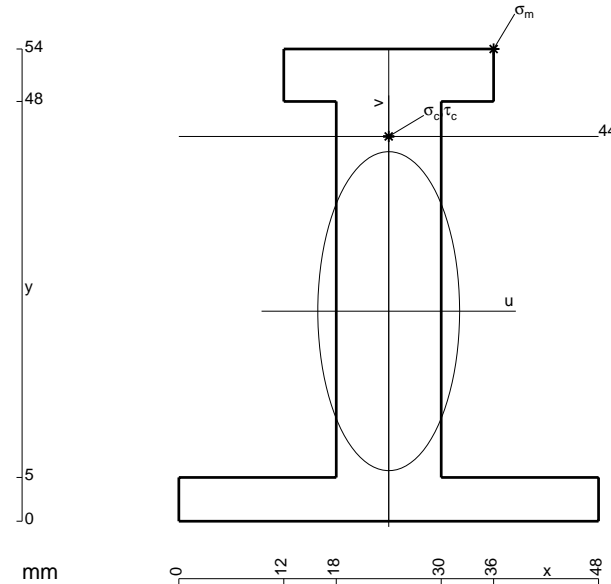

- A = 900. mm²
- J_u = 299580. mm⁴
- J_v = 59184. mm⁴
- y_g = 24.02 mm
- T_y = -2620. N
- M_x = -1991200. Nmm
- x_m = 36. mm
- y_m = 54. mm
- u_m = 12. mm
- v_m = 29.98 mm
- σ_m = -Mv/J_u = 199.3 N/mm²
- x_c = 24. mm
- y_c = 44. mm
- v_c = 19.98 mm
- σ_c = -Mv/J_u = 132.8 N/mm²
- τ_c = 3.6 N/mm²
- σ_o = √σ²+3τ² = 132.9 N/mm²
- S = 4940. mm³

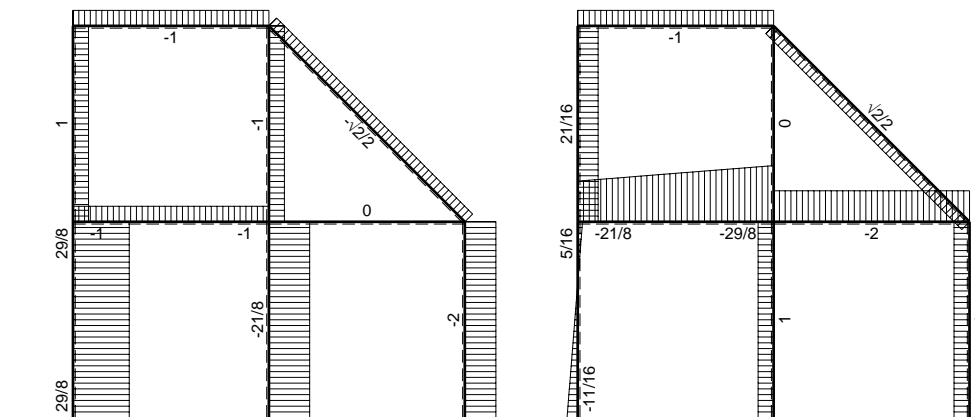
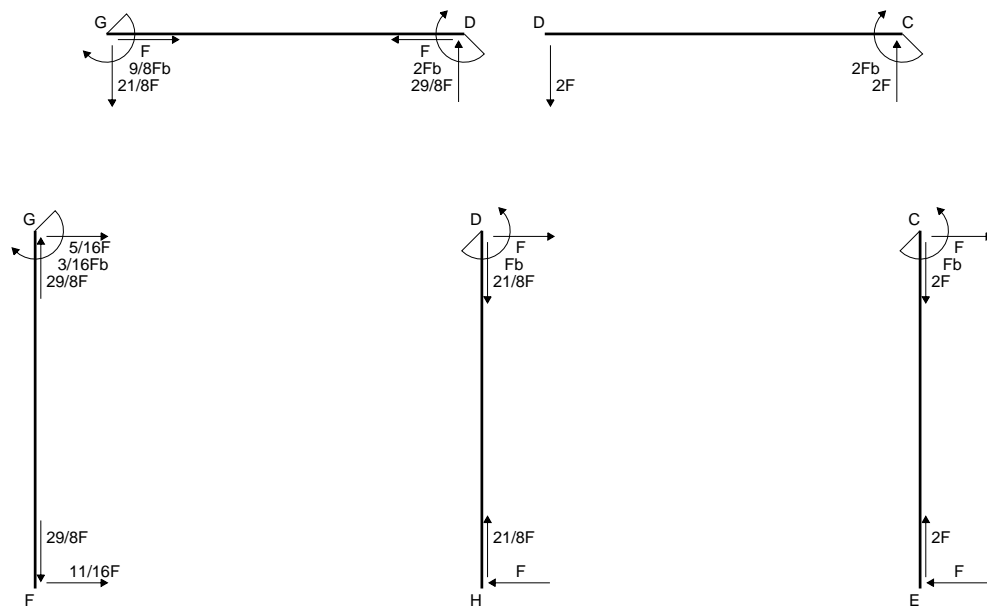
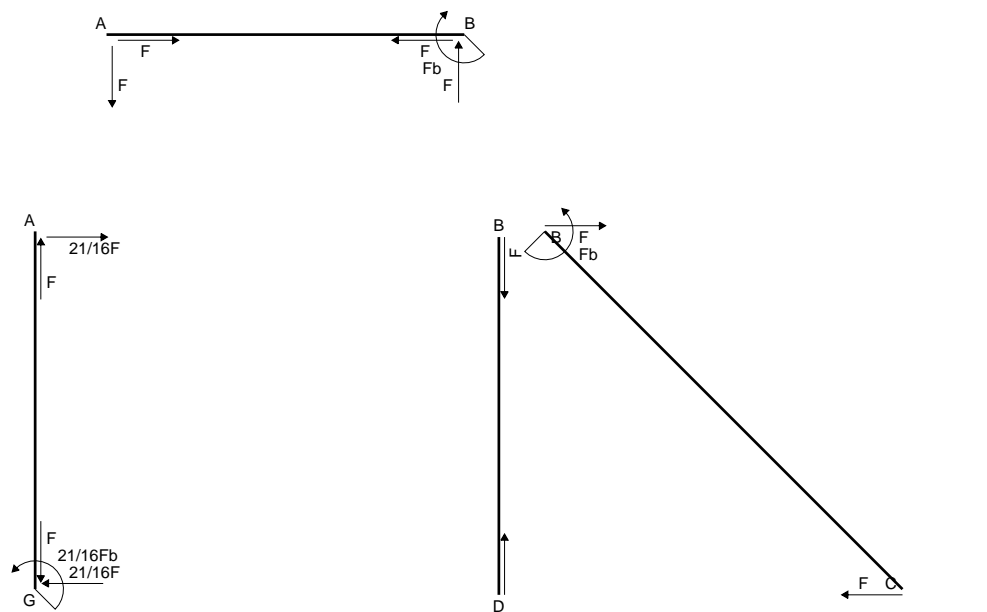

← ⊕ → F

↑ ⊕ ↓ F

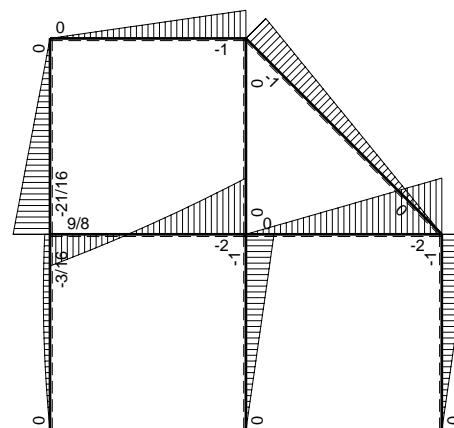

⊕ ⊖ Fb

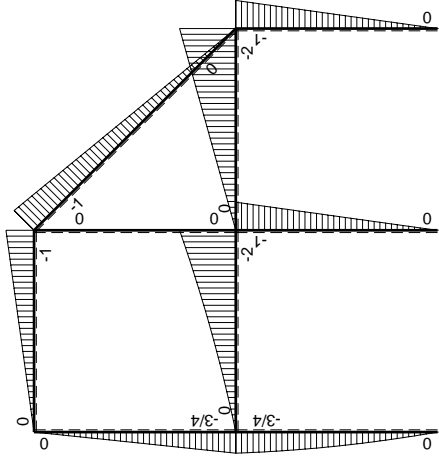
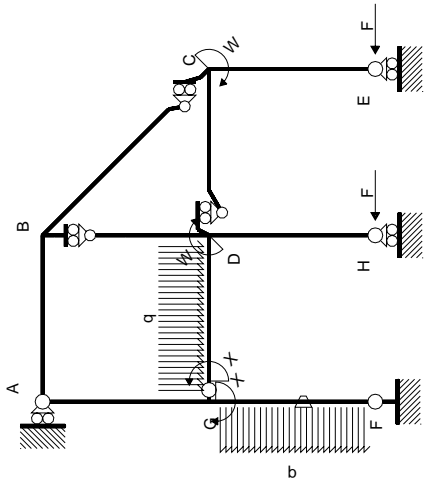

Schema di calcolo iperstatico

M_0 flessione da carichi assegnati

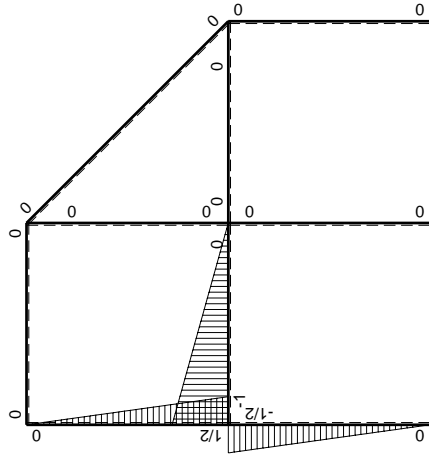

M_x flessione da iperstatica $X=1$

Quadro contributi PLV per iperstatica $X=W_{GD}$

→	$M_x(x)$	$M_o(x)$	θ	$M_x M_o$	$M_x \theta$	$M_x M_x$	$\int M_x(M_o/EJ+\theta)dx$	$\int x M_x M_x/EJ dx$
AB b	0	-Fx	0	0	0	0	0+0	0
BA b	0	Fb-Fx	0	0	0	0		
BC $\sqrt{2}b$	0	-Fb+ $\sqrt{2}/2Fx$	0	0	0	0	0	0
BD b	0	0	0	0	0	0	0+0	0
DB b	0	0	0	0	0	0		
DC b	0	-2Fx	0	0	0	0	0+0	0
CD b	0	2Fb-2Fx	0	0	0	0		
CE b	0	-Fb+Fx	0	0	0	0	0+0	0
EC b	0	Fx	0	0	0	0		
FG b	-1/2x/b	-5/4Fx+1/2qx ²	-Fb/EJ	5/8Fx ² /b-1/4qx ³ /b	1/2Fx/EJ	1/4x ² /b ²	(7/48+1/4)Fb ² /EJ	1/12Xb/EJ
GF b	1/2-1/2x/b	3/4Fb-1/4Fx-1/2qx ²	Fb/EJ	3/8Fb-1/2Fx-1/8Fx ² /b+1/4qx ³ /b	1/2Fb/EJ-1/2Fx/EJ	1/4-1/2x/b+1/4x ² /b ²		
GD b	-1+x/b	-3/2Fx-1/2qx ²	0	3/2Fx-Fx ² /b-1/2qx ³ /b	0	1-2x/b+x ² /b ²	(7/24+0)Fb ² /EJ	1/3Xb/EJ
DG b	x/b	2Fb-5/2Fx+1/2qx ²	0	2Fx-5/2Fx ² /b+1/2qx ³ /b	0	x ² /b ²		
DH b	0	-Fb+Fx	0	0	0	0	0+0	0
HD b	0	Fx	0	0	0	0		
GA b	1/2-1/2x/b	-3/4Fb+3/4Fx	0	-3/8Fb+3/4Fx-3/8Fx ² /b	0	1/4-1/2x/b+1/4x ² /b ²	(-1/8+0)Fb ² /EJ	1/12Xb/EJ
AG b	-1/2x/b	3/4Fx	0	-3/8Fx ² /b	0	1/4x ² /b ²		
	totali						9/16Fb ² /EJ	1/2Xb/EJ
	iperstatica $X=W_{GD}$						-9/8Fb	

Sviluppi di calcolo iperstatica

$$L_{FG}^{xx} = \int_0^b (1/4 x^2/b^2) 1/EJ dx = [1/12 x^3/b^2]_0^b 1/EJ$$

$$= (1/12 b) 1/EJ = 1/12 b/EJ$$

$$L_{GF}^{xx} = \int_0^b (1/4 - 1/2 x/b + 1/4 x^2/b^2) 1/EJ dx = [1/4 x - 1/4 x^2/b + 1/12 x^3/b^2]_0^b 1/EJ$$

$$= (1/4 b - 1/4 b + 1/12 b) 1/EJ = 1/12 b/EJ$$

$$L_{GD}^{xx} = \int_0^b (1 - 2 x/b + x^2/b^2) 1/EJ dx = [x - x^2/b + 1/3 x^3/b^2]_0^b 1/EJ$$

$$= (b - b + 1/3 b) 1/EJ = 1/3 b/EJ$$

$$L_{DG}^{xx} = \int_0^b (x^2/b^2) 1/EJ dx = [1/3 x^3/b^2]_0^b 1/EJ$$

$$= (1/3 b) 1/EJ = 1/3 b/EJ$$

$$L_{GA}^{xx} = \int_0^b (1/4 - 1/2 x/b + 1/4 x^2/b^2) 1/EJ dx = [1/4 x - 1/4 x^2/b + 1/12 x^3/b^2]_0^b 1/EJ$$

$$= (1/4 b - 1/4 b + 1/12 b) 1/EJ = 1/12 b/EJ$$

$$L_{AG}^{xx} = \int_0^b (1/4 x^2/b^2) 1/EJ dx = [1/12 x^3/b^2]_0^b 1/EJ$$

$$= (1/12 b) 1/EJ = 1/12 b/EJ$$

$$L_{FG}^{x\theta} = \int_0^b (5/8 x^2/b^2 - 1/4 x^3/b^3) Fb 1/EJ dx + \int_0^b (1/2 x/b) \theta dx$$

$$= [5/24 x^3/b^2 - 1/16 x^4/b^3]_0^b Fb 1/EJ + [1/4 x^2/b]_0^b \theta$$

$$= (5/24 b - 1/16 b) Fb 1/EJ + (1/4 b) \theta = 19/48 Fb^2/EJ$$

$$L_{GF}^{x\theta} = \int_0^b (3/8 - 1/2 x/b - 1/8 x^2/b^2 + 1/4 x^3/b^3) Fb 1/EJ dx + \int_0^b (-1/2 + 1/2 x/b) \theta dx$$

$$= [3/8 x - 1/4 x^2/b - 1/24 x^3/b^2 + 1/16 x^4/b^3]_0^b Fb 1/EJ + [-1/2 x + 1/4 x^2/b]_0^b \theta$$

$$= (3/8 b - 1/4 b - 1/24 b + 1/16 b) Fb 1/EJ + (-1/2 b + 1/4 b) \theta = 19/48 Fb^2/EJ$$

$$L_{GD}^{x\theta} = \int_0^b (3/2 x/b - x^2/b^2 - 1/2 x^3/b^3) Fb 1/EJ dx = [3/4 x^2/b - 1/3 x^3/b^2 - 1/8 x^4/b^3]_0^b Fb 1/EJ$$

$$= (3/4 b - 1/3 b - 1/8 b) Fb 1/EJ = 7/24 Fb^2/EJ$$

$$L_{DG}^{x\theta} = \int_0^b (2 x/b - 5/2 x^2/b^2 + 1/2 x^3/b^3) Fb 1/EJ dx = [x^2/b - 5/6 x^3/b^2 + 1/8 x^4/b^3]_0^b Fb 1/EJ$$

$$= (b - 5/6 b + 1/8 b) Fb 1/EJ = 7/24 Fb^2/EJ$$

$$L_{GA}^{x\theta} = \int_0^b (-3/8 + 3/4 x/b - 3/8 x^2/b^2) Fb 1/EJ dx = [-3/8 x + 3/8 x^2/b - 1/8 x^3/b^2]_0^b Fb 1/EJ$$

$$= (-3/8 b + 3/8 b - 1/8 b) Fb 1/EJ = -1/8 Fb^2/EJ$$

$$L_{AG}^{x\theta} = \int_0^b (-3/8 x^2/b^2) Fb 1/EJ dx = [-1/8 x^3/b^2]_0^b Fb 1/EJ$$

$$= (-1/8 b) Fb 1/EJ = -1/8 Fb^2/EJ$$

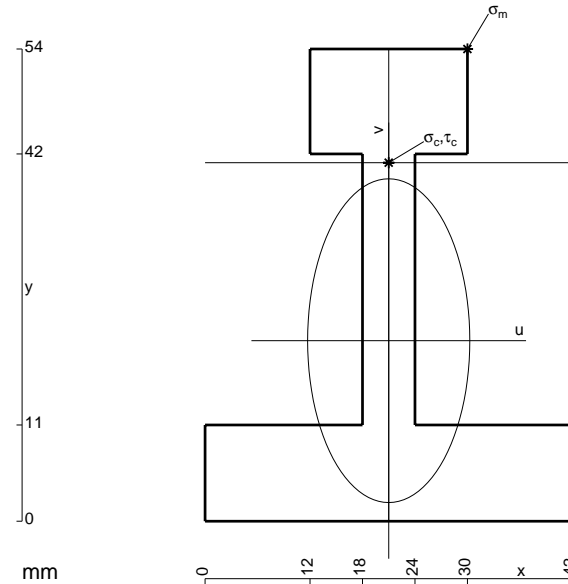

- A = 864. mm²
- J_u = 296124. mm⁴
- J_v = 74304. mm⁴
- y_g = 20.65 mm
- T_y = -2300. N
- M_x = -1863000. Nmm
- x_m = 30. mm
- y_m = 54. mm
- u_m = 9. mm
- v_m = 33.35 mm
- σ_m = -Mv/J_u = 209.8 N/mm²
- x_c = 21. mm
- y_c = 41. mm
- v_c = 20.35 mm
- σ_c = -Mv/J_u = 128.1 N/mm²
- τ_c = 7.811 N/mm²
- σ_σ = √σ²+3τ² = 128.8 N/mm²
- S = 6034. mm³

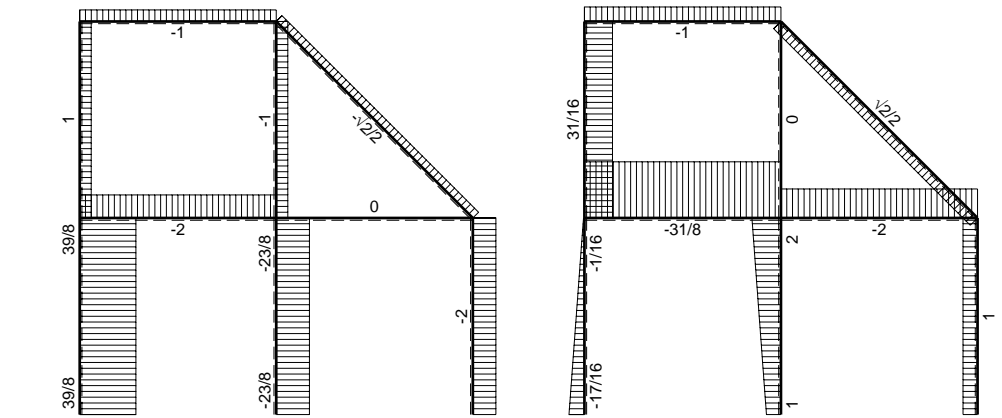
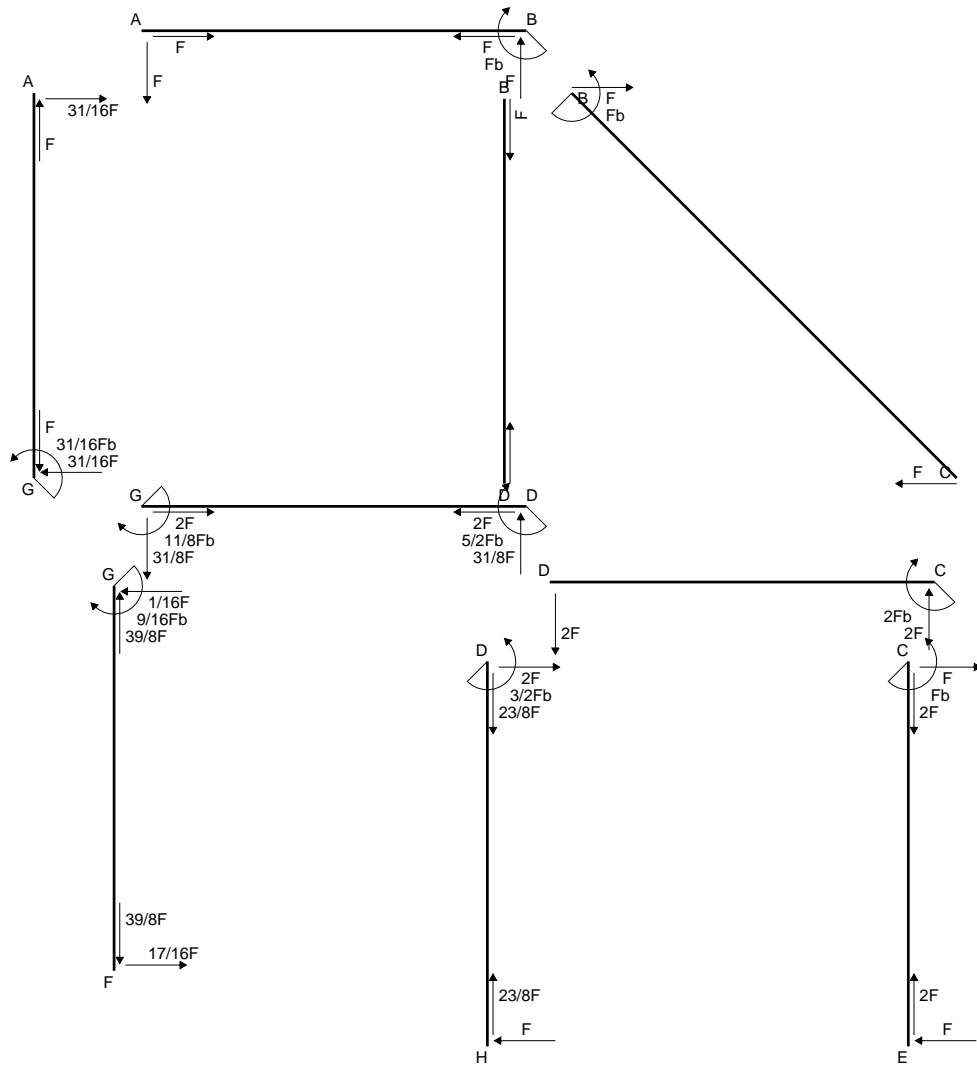

← ⊕ → F

↑ ⊕ ↓ F

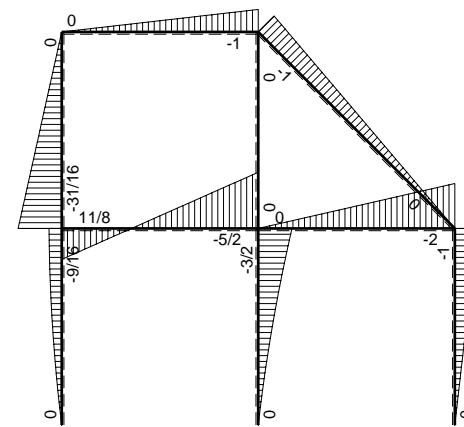

⊕ ⊖ F_b

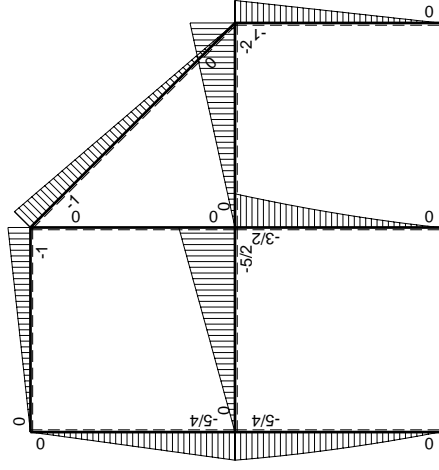
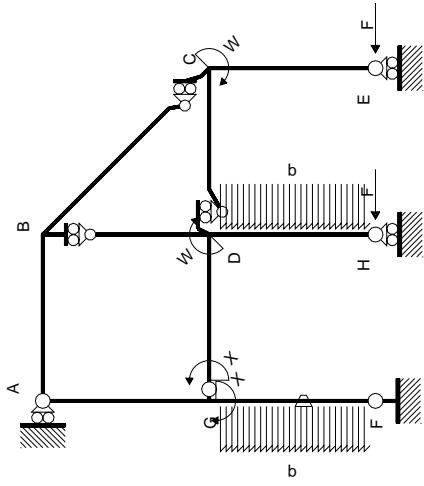

Schema di calcolo iperstatico

M_0 flessione da carichi assegnati

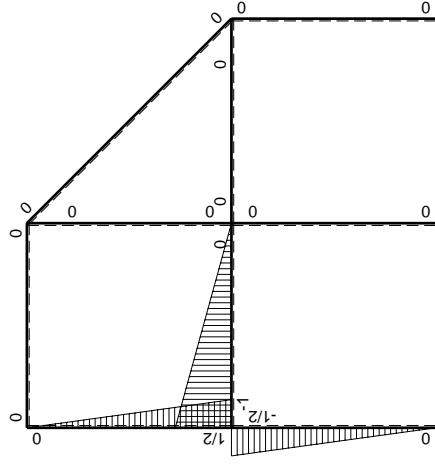

M_x flessione da iperstatica $X=1$

Quadro contributi PLV per iperstatica $X=W_{GD}$

→	$M_x(x)$	$M_o(x)$	θ	$M_x M_o$	$M_x \theta$	$M_x M_x$	$\int M_x(M_o/EJ+\theta)dx$	$\int X M_x M_x / EJ dx$
AB b	0	-Fx	0	0	0	0	0+0	0
BA b	0	Fb-Fx	0	0	0	0	0	0
BC $\sqrt{2}b$	0	-Fb+ $\sqrt{2}/2Fx$	0	0	0	0	0	0
BD b	0	0	0	0	0	0	0+0	0
DB b	0	0	0	0	0	0	0	0
DC b	0	-2Fx	0	0	0	0	0+0	0
CD b	0	2Fb-2Fx	0	0	0	0	0	0
CE b	0	-Fb+Fx	0	0	0	0	0+0	0
EC b	0	Fx	0	0	0	0	0	0
FG b	-1/2x/b	-7/4Fx+1/2qx ²	-Fb/EJ	7/8Fx ² /b-1/4qx ³ /b	1/2Fx/EJ	1/4x ² /b ²	(11/48+1/4)Fb ² /EJ	1/12Xb/EJ
GF b	1/2-1/2x/b	5/4Fb-3/4Fx-1/2qx ²	Fb/EJ	5/8Fb-Fx+1/8Fx ² /b+1/4qx ³ /b	1/2Fb/EJ-1/2Fx/EJ	1/4-1/2x/b+1/4x ² /b ²		
GD b	-1+x/b	-5/2Fx	0	5/2Fx-5/2Fx ² /b	0	1-2x/b+x ² /b ²	(5/12+0)Fb ² /EJ	1/3Xb/EJ
DG b	x/b	5/2Fb-5/2Fx	0	5/2Fx-5/2Fx ² /b	0	x ² /b ²		
DH b	0	-3/2Fb+2Fx-1/2qx ²	0	0	0	0	0+0	0
HD b	0	Fx+1/2qx ²	0	0	0	0		
GA b	1/2-1/2x/b	-5/4Fb+5/4Fx	0	-5/8Fb+5/4Fx-5/8Fx ² /b	0	1/4-1/2x/b+1/4x ² /b ²	(-5/24+0)Fb ² /EJ	1/12Xb/EJ
AG b	-1/2x/b	5/4Fx	0	-5/8Fx ² /b	0	1/4x ² /b ²		
	totali						11/16Fb ² /EJ	1/2Xb/EJ
	iperstatica $X=W_{GD}$						-11/8Fb	

Sviluppi di calcolo iperstatica

$$L_{FG}^{xx} = \int_0^b (1/4 x^2/b^2) 1/EJ dx = [1/12 x^3/b^2]_0^b 1/EJ$$

$$= (1/12 b) 1/EJ = 1/12 b/EJ$$

$$L_{GF}^{xx} = \int_0^b (1/4 - 1/2 x/b + 1/4 x^2/b^2) 1/EJ dx = [1/4 x - 1/4 x^2/b + 1/12 x^3/b^2]_0^b 1/EJ$$

$$= (1/4 b - 1/4 b + 1/12 b) 1/EJ = 1/12 b/EJ$$

$$L_{GD}^{xx} = \int_0^b (1 - 2 x/b + x^2/b^2) 1/EJ dx = [x - x^2/b + 1/3 x^3/b^2]_0^b 1/EJ$$

$$= (b - b + 1/3 b) 1/EJ = 1/3 b/EJ$$

$$L_{DG}^{xx} = \int_0^b (x^2/b^2) 1/EJ dx = [1/3 x^3/b^2]_0^b 1/EJ$$

$$= (1/3 b) 1/EJ = 1/3 b/EJ$$

$$L_{GA}^{xx} = \int_0^b (1/4 - 1/2 x/b + 1/4 x^2/b^2) 1/EJ dx = [1/4 x - 1/4 x^2/b + 1/12 x^3/b^2]_0^b 1/EJ$$

$$= (1/4 b - 1/4 b + 1/12 b) 1/EJ = 1/12 b/EJ$$

$$L_{AG}^{xx} = \int_0^b (1/4 x^2/b^2) 1/EJ dx = [1/12 x^3/b^2]_0^b 1/EJ$$

$$= (1/12 b) 1/EJ = 1/12 b/EJ$$

$$L_{FG}^{xo} = \int_0^b (7/8 x^2/b^2 - 1/4 x^3/b^3) Fb 1/EJ dx + \int_0^b (1/2 x/b) \theta dx$$

$$= [7/24 x^3/b^2 - 1/16 x^4/b^3]_0^b Fb 1/EJ + [1/4 x^2/b]_0^b \theta$$

$$= (7/24 b - 1/16 b) Fb 1/EJ + (1/4 b) \theta = 23/48 Fb^2/EJ$$

$$L_{GF}^{xo} = \int_0^b (5/8 - x/b + 1/8 x^2/b^2 + 1/4 x^3/b^3) Fb 1/EJ dx + \int_0^b (-1/2 + 1/2 x/b) \theta dx$$

$$= [5/8 x - 1/2 x^2/b + 1/24 x^3/b^2 + 1/16 x^4/b^3]_0^b Fb 1/EJ + [-1/2 x + 1/4 x^2/b]_0^b \theta$$

$$= (5/8 b - 1/2 b + 1/24 b + 1/16 b) Fb 1/EJ + (-1/2 b + 1/4 b) \theta = 23/48 Fb^2/EJ$$

$$L_{GD}^{xo} = \int_0^b (5/2 x/b - 5/2 x^2/b^2) Fb 1/EJ dx = [5/4 x^2/b - 5/6 x^3/b^2]_0^b Fb 1/EJ$$

$$= (5/4 b - 5/6 b) Fb 1/EJ = 5/12 Fb^2/EJ$$

$$L_{DG}^{xo} = \int_0^b (5/2 x/b - 5/2 x^2/b^2) Fb 1/EJ dx = [5/4 x^2/b - 5/6 x^3/b^2]_0^b Fb 1/EJ$$

$$= (5/4 b - 5/6 b) Fb 1/EJ = 5/12 Fb^2/EJ$$

$$L_{GA}^{xo} = \int_0^b (-5/8 + 5/4 x/b - 5/8 x^2/b^2) Fb 1/EJ dx = [-5/8 x + 5/8 x^2/b - 5/24 x^3/b^2]_0^b Fb 1/EJ$$

$$= (-5/8 b + 5/8 b - 5/24 b) Fb 1/EJ = -5/24 Fb^2/EJ$$

$$L_{AG}^{xo} = \int_0^b (-5/8 x^2/b^2) Fb 1/EJ dx = [-5/24 x^3/b^2]_0^b Fb 1/EJ$$

$$= (-5/24 b) Fb 1/EJ = -5/24 Fb^2/EJ$$

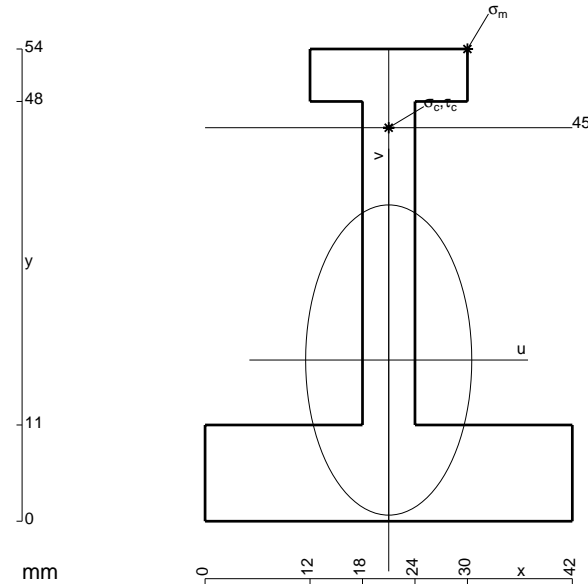

- A = 792. mm²
- J_u = 249320. mm⁴
- J_v = 71496. mm⁴
- y_g = 18.43 mm
- T_y = -1780. N
- M_x = -1530800. Nmm
- x_m = 30. mm
- y_m = 54. mm
- u_m = 9. mm
- v_m = 35.57 mm
- σ_m = -Mv/J_u = 218.4 N/mm²
- x_c = 21. mm
- y_c = 45. mm
- v_c = 26.57 mm
- σ_c = -Mv/J_u = 163.1 N/mm²
- τ_c = 4.786 N/mm²
- σ_o = √σ²+3τ² = 163.3 N/mm²
- S = 4023. mm³

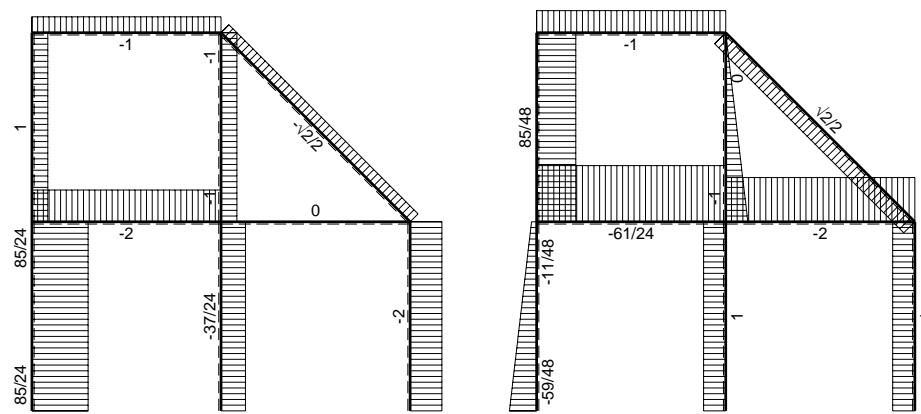
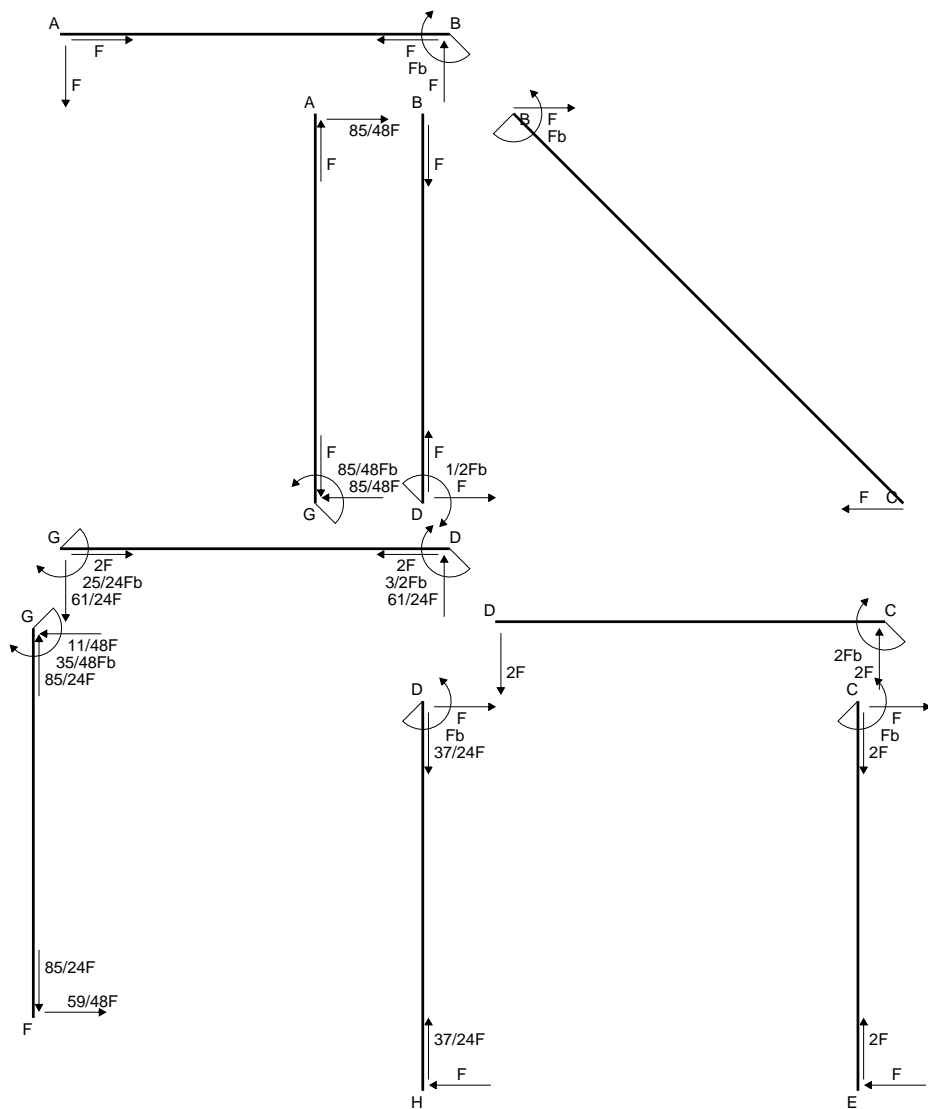

← ⊕ → F

↑ ⊕ ↓ F

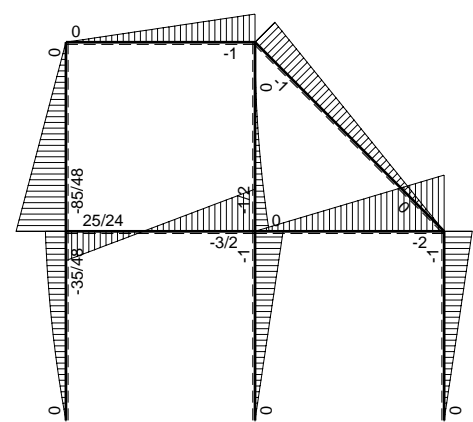

⊕ ⊖ Fb

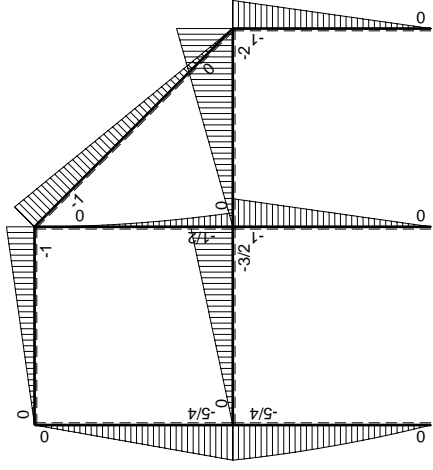
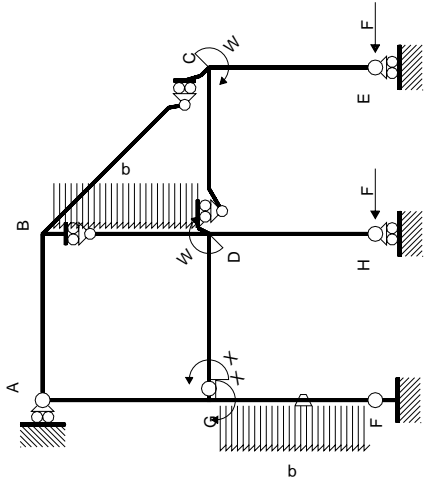

Schema di calcolo iperstatico

M_0 flessione da carichi assegnati

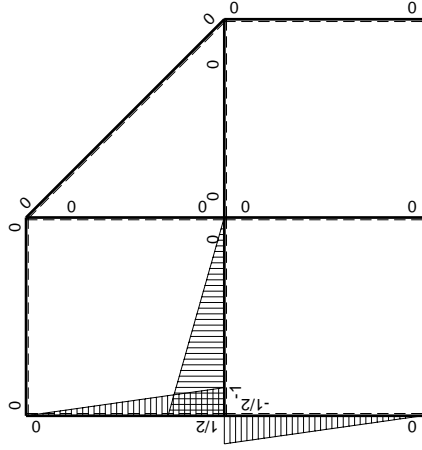

M_X flessione da iperstatica $X=1$

Quadro contributi PLV per iperstatica $X=W_{GD}$

→	$M_x(x)$	$M_o(x)$	θ	$M_x M_o$	$M_x \theta$	$M_x M_x$	$\int M_x(M_o/EJ+\theta)dx$	$\int X M_x M_x / EJ dx$
AB b	0	-Fx	0	0	0	0	0+0	0
BA b	0	Fb-Fx	0	0	0	0	0	0
BC $\sqrt{2}b$	0	-Fb+ $\sqrt{2}/2Fx$	0	0	0	0	0	0
BD b	0	-1/2qx ²	0	0	0	0	0+0	0
DB b	0	1/2Fb-Fx+1/2qx ²	0	0	0	0	0	0
DC b	0	-2Fx	0	0	0	0	0+0	0
CD b	0	2Fb-2Fx	0	0	0	0	0	0
CE b	0	-Fb+Fx	0	0	0	0	0+0	0
EC b	0	Fx	0	0	0	0	0	0
FG b	-1/2x/b	-7/4Fx+1/2qx ²	-Fb/EJ	7/8Fx ² /b-1/4qx ³ /b	1/2Fx/EJ	1/4x ² /b ²	(11/48+1/4)Fb ² /EJ	1/12Xb/EJ
GF b	1/2-1/2x/b	5/4Fb-3/4Fx-1/2qx ²	Fb/EJ	5/8Fb-Fx+1/8Fx ² /b+1/4qx ³ /b	1/2Fb/EJ-1/2Fx/EJ	1/4-1/2x/b+1/4x ² /b ²		
GD b	-1+x/b	-3/2Fx	0	3/2Fx-3/2Fx ² /b	0	1-2x/b+x ² /b ²	(1/4+0)Fb ² /EJ	1/3Xb/EJ
DG b	x/b	3/2Fb-3/2Fx	0	3/2Fx-3/2Fx ² /b	0	x ² /b ²		
DH b	0	-Fb+Fx	0	0	0	0	0+0	0
HD b	0	Fx	0	0	0	0	0	0
GA b	1/2-1/2x/b	-5/4Fb+5/4Fx	0	-5/8Fb+5/4Fx-5/8Fx ² /b	0	1/4-1/2x/b+1/4x ² /b ²	(-5/24+0)Fb ² /EJ	1/12Xb/EJ
AG b	-1/2x/b	5/4Fx	0	-5/8Fx ² /b	0	1/4x ² /b ²		
	totali						25/48Fb ² /EJ	1/2Xb/EJ
	iperstatica $X=W_{GD}$						-25/24Fb	

Sviluppi di calcolo iperstatica

$$L_{FG}^{xx} = \int_0^b (1/4 x^2/b^2) 1/EJ dx = [1/12 x^3/b^2]_0^b 1/EJ$$

$$= (1/12 b) 1/EJ = 1/12 b/EJ$$

$$L_{GF}^{xx} = \int_0^b (1/4 -1/2 x/b +1/4 x^2/b^2) 1/EJ dx = [1/4 x -1/4 x^2/b +1/12 x^3/b^2]_0^b 1/EJ$$

$$= (1/4 b -1/4 b +1/12 b) 1/EJ = 1/12 b/EJ$$

$$L_{GD}^{xx} = \int_0^b (1 -2 x/b + x^2/b^2) 1/EJ dx = [x - x^2/b +1/3 x^3/b^2]_0^b 1/EJ$$

$$= (b - b +1/3 b) 1/EJ = 1/3 b/EJ$$

$$L_{DG}^{xx} = \int_0^b (x^2/b^2) 1/EJ dx = [1/3 x^3/b^2]_0^b 1/EJ$$

$$= (1/3 b) 1/EJ = 1/3 b/EJ$$

$$L_{GA}^{xx} = \int_0^b (1/4 -1/2 x/b +1/4 x^2/b^2) 1/EJ dx = [1/4 x -1/4 x^2/b +1/12 x^3/b^2]_0^b 1/EJ$$

$$= (1/4 b -1/4 b +1/12 b) 1/EJ = 1/12 b/EJ$$

$$L_{AG}^{xx} = \int_0^b (1/4 x^2/b^2) 1/EJ dx = [1/12 x^3/b^2]_0^b 1/EJ$$

$$= (1/12 b) 1/EJ = 1/12 b/EJ$$

$$L_{FG}^{xo} = \int_0^b (7/8 x^2/b^2 -1/4 x^3/b^3) Fb 1/EJ dx + \int_0^b (1/2 x/b) \theta dx$$

$$= [7/24 x^3/b^2 -1/16 x^4/b^3]_0^b Fb 1/EJ + [1/4 x^2/b]_0^b \theta$$

$$= (7/24 b -1/16 b) Fb 1/EJ + (1/4 b) \theta = 23/48 Fb^2/EJ$$

$$L_{GF}^{xo} = \int_0^b (5/8 - x/b +1/8 x^2/b^2 +1/4 x^3/b^3) Fb 1/EJ dx + \int_0^b (-1/2 +1/2 x/b) \theta dx$$

$$= [5/8 x -1/2 x^2/b +1/24 x^3/b^2 +1/16 x^4/b^3]_0^b Fb 1/EJ + [-1/2 x +1/4 x^2/b]_0^b \theta$$

$$= (5/8 b -1/2 b +1/24 b +1/16 b) Fb 1/EJ + (-1/2 b +1/4 b) \theta = 23/48 Fb^2/EJ$$

$$L_{GD}^{xo} = \int_0^b (3/2 x/b -3/2 x^2/b^2) Fb 1/EJ dx = [3/4 x^2/b -1/2 x^3/b^2]_0^b Fb 1/EJ$$

$$= (3/4 b -1/2 b) Fb 1/EJ = 1/4 Fb^2/EJ$$

$$L_{DG}^{xo} = \int_0^b (3/2 x/b -3/2 x^2/b^2) Fb 1/EJ dx = [3/4 x^2/b -1/2 x^3/b^2]_0^b Fb 1/EJ$$

$$= (3/4 b -1/2 b) Fb 1/EJ = 1/4 Fb^2/EJ$$

$$L_{GA}^{xo} = \int_0^b (-5/8 +5/4 x/b -5/8 x^2/b^2) Fb 1/EJ dx = [-5/8 x +5/8 x^2/b -5/24 x^3/b^2]_0^b Fb 1/EJ$$

$$= (-5/8 b +5/8 b -5/24 b) Fb 1/EJ = -5/24 Fb^2/EJ$$

$$L_{AG}^{xo} = \int_0^b (-5/8 x^2/b^2) Fb 1/EJ dx = [-5/24 x^3/b^2]_0^b Fb 1/EJ$$

$$= (-5/24 b) Fb 1/EJ = -5/24 Fb^2/EJ$$

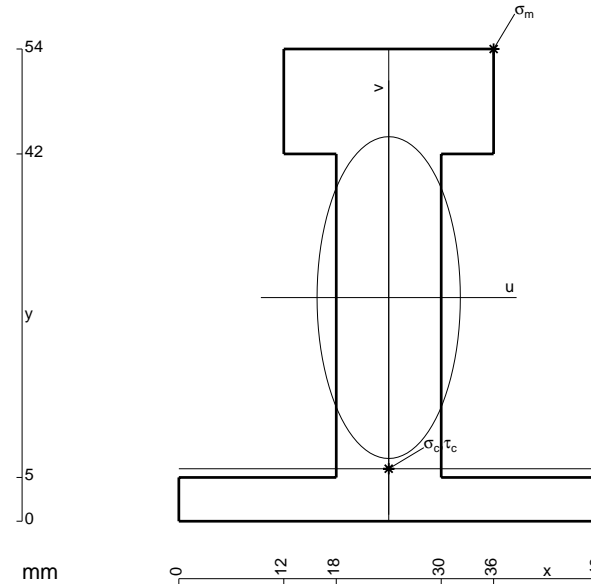

- A = 972. mm²
- J_u = 329140. mm⁴
- J_v = 65232. mm⁴
- y_g = 25.57 mm
- T_y = -2920. N
- M_x = -2657200. Nmm
- x_m = 36. mm
- y_m = 54. mm
- u_m = 12. mm
- v_m = 28.43 mm
- σ_m = -Mv/J_u = 229.5 N/mm²
- x_c = 24. mm
- y_c = 6. mm
- v_c = -19.57 mm
- σ_c = -Mv/J_u = -158. N/mm²
- τ_c = 4.272 N/mm²
- σ_o = √σ²+3τ² = 158.2 N/mm²
- S = 5779. mm³

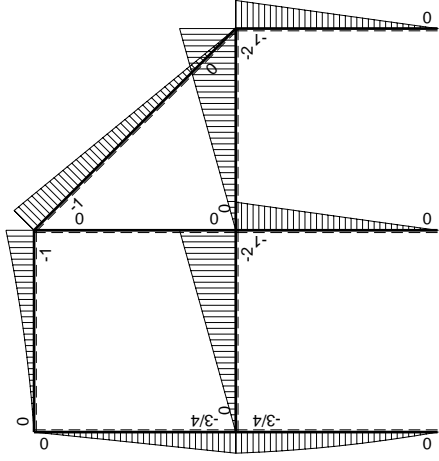
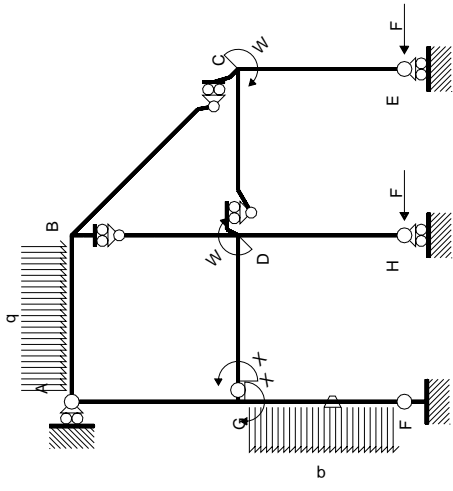

Schema di calcolo iperstatico

M_0 flessione da carichi assegnati

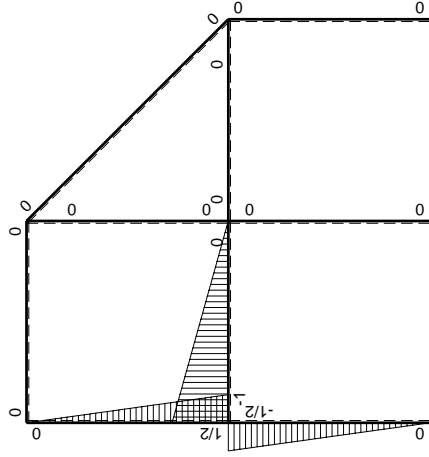

M_x flessione da iperstatica $X=1$

Quadro contributi PLV per iperstatica $X=W_{GD}$

→	$M_x(x)$	$M_o(x)$	θ	$M_x M_o$	$M_x \theta$	$M_x M_x$	$\int M_x(M_o/EJ+\theta)dx$	$\int x M_x M_x/EJ dx$
AB b	0	$-1/2Fx-1/2qx^2$	0	0	0	0	0+0	0
BA b	0	$Fb-3/2Fx+1/2qx^2$	0	0	0	0		
BC $\sqrt{2}b$	0	$-Fb+\sqrt{2}/2Fx$	0	0	0	0	0	0
BD b	0	0	0	0	0	0	0+0	0
DB b	0	0	0	0	0	0		
DC b	0	$-2Fx$	0	0	0	0	0+0	0
CD b	0	$2Fb-2Fx$	0	0	0	0		
CE b	0	$-Fb+Fx$	0	0	0	0	0+0	0
EC b	0	Fx	0	0	0	0		
FG b	$-1/2x/b$	$-5/4Fx+1/2qx^2$	$-Fb/EJ$	$5/8Fx^2/b-1/4qx^3/b$	$1/2Fx/EJ$	$1/4x^2/b^2$	$(7/48+1/4)Fb^2/EJ$	$1/12Xb/EJ$
GF b	$1/2-1/2x/b$	$3/4Fb-1/4Fx-1/2qx^2$	Fb/EJ	$3/8Fb-1/2Fx-1/8Fx^2/b+1/4qx^3/b$	$1/2Fb/EJ-1/2Fx/EJ$	$1/4-1/2x/b+1/4x^2/b^2$		
GD b	$-1+x/b$	$-2Fx$	0	$2Fx-2Fx^2/b$	0	$1-2x/b+x^2/b^2$	$(1/3+0)Fb^2/EJ$	$1/3Xb/EJ$
DG b	x/b	$2Fb-2Fx$	0	$2Fx-2Fx^2/b$	0	x^2/b^2		
DH b	0	$-Fb+Fx$	0	0	0	0	0+0	0
HD b	0	Fx	0	0	0	0		
GA b	$1/2-1/2x/b$	$-3/4Fb+3/4Fx$	0	$-3/8Fb+3/4Fx-3/8Fx^2/b$	0	$1/4-1/2x/b+1/4x^2/b^2$	$(-1/8+0)Fb^2/EJ$	$1/12Xb/EJ$
AG b	$-1/2x/b$	$3/4Fx$	0	$-3/8Fx^2/b$	0	$1/4x^2/b^2$		
	totali						$29/48Fb^2/EJ$	$1/2Xb/EJ$
	iperstatica $X=W_{GD}$						$-29/24Fb$	

Sviluppi di calcolo iperstatica

$$L_{FG}^{xx} = \int_0^b (1/4 x^2/b^2) 1/EJ dx = [1/12 x^3/b^2]_0^b 1/EJ$$

$$= (1/12 b) 1/EJ = 1/12 b/EJ$$

$$L_{GF}^{xx} = \int_0^b (1/4 - 1/2 x/b + 1/4 x^2/b^2) 1/EJ dx = [1/4 x - 1/4 x^2/b + 1/12 x^3/b^2]_0^b 1/EJ$$

$$= (1/4 b - 1/4 b + 1/12 b) 1/EJ = 1/12 b/EJ$$

$$L_{GD}^{xx} = \int_0^b (1 - 2 x/b + x^2/b^2) 1/EJ dx = [x - x^2/b + 1/3 x^3/b^2]_0^b 1/EJ$$

$$= (b - b + 1/3 b) 1/EJ = 1/3 b/EJ$$

$$L_{DG}^{xx} = \int_0^b (x^2/b^2) 1/EJ dx = [1/3 x^3/b^2]_0^b 1/EJ$$

$$= (1/3 b) 1/EJ = 1/3 b/EJ$$

$$L_{GA}^{xx} = \int_0^b (1/4 - 1/2 x/b + 1/4 x^2/b^2) 1/EJ dx = [1/4 x - 1/4 x^2/b + 1/12 x^3/b^2]_0^b 1/EJ$$

$$= (1/4 b - 1/4 b + 1/12 b) 1/EJ = 1/12 b/EJ$$

$$L_{AG}^{xx} = \int_0^b (1/4 x^2/b^2) 1/EJ dx = [1/12 x^3/b^2]_0^b 1/EJ$$

$$= (1/12 b) 1/EJ = 1/12 b/EJ$$

$$L_{FG}^{xo} = \int_0^b (5/8 x^2/b^2 - 1/4 x^3/b^3) Fb 1/EJ dx + \int_0^b (1/2 x/b) \theta dx$$

$$= [5/24 x^3/b^2 - 1/16 x^4/b^3]_0^b Fb 1/EJ + [1/4 x^2/b]_0^b \theta$$

$$= (5/24 b - 1/16 b) Fb 1/EJ + (1/4 b) \theta = 19/48 Fb^2/EJ$$

$$L_{GF}^{xo} = \int_0^b (3/8 - 1/2 x/b - 1/8 x^2/b^2 + 1/4 x^3/b^3) Fb 1/EJ dx + \int_0^b (-1/2 + 1/2 x/b) \theta dx$$

$$= [3/8 x - 1/4 x^2/b - 1/24 x^3/b^2 + 1/16 x^4/b^3]_0^b Fb 1/EJ + [-1/2 x + 1/4 x^2/b]_0^b \theta$$

$$= (3/8 b - 1/4 b - 1/24 b + 1/16 b) Fb 1/EJ + (-1/2 b + 1/4 b) \theta = 19/48 Fb^2/EJ$$

$$L_{GD}^{xo} = \int_0^b (2 x/b - 2 x^2/b^2) Fb 1/EJ dx = [x^2/b - 2/3 x^3/b^2]_0^b Fb 1/EJ$$

$$= (b - 2/3 b) Fb 1/EJ = 1/3 Fb^2/EJ$$

$$L_{DG}^{xo} = \int_0^b (2 x/b - 2 x^2/b^2) Fb 1/EJ dx = [x^2/b - 2/3 x^3/b^2]_0^b Fb 1/EJ$$

$$= (b - 2/3 b) Fb 1/EJ = 1/3 Fb^2/EJ$$

$$L_{GA}^{xo} = \int_0^b (-3/8 + 3/4 x/b - 3/8 x^2/b^2) Fb 1/EJ dx = [-3/8 x + 3/8 x^2/b - 1/8 x^3/b^2]_0^b Fb 1/EJ$$

$$= (-3/8 b + 3/8 b - 1/8 b) Fb 1/EJ = -1/8 Fb^2/EJ$$

$$L_{AG}^{xo} = \int_0^b (-3/8 x^2/b^2) Fb 1/EJ dx = [-1/8 x^3/b^2]_0^b Fb 1/EJ$$

$$= (-1/8 b) Fb 1/EJ = -1/8 Fb^2/EJ$$

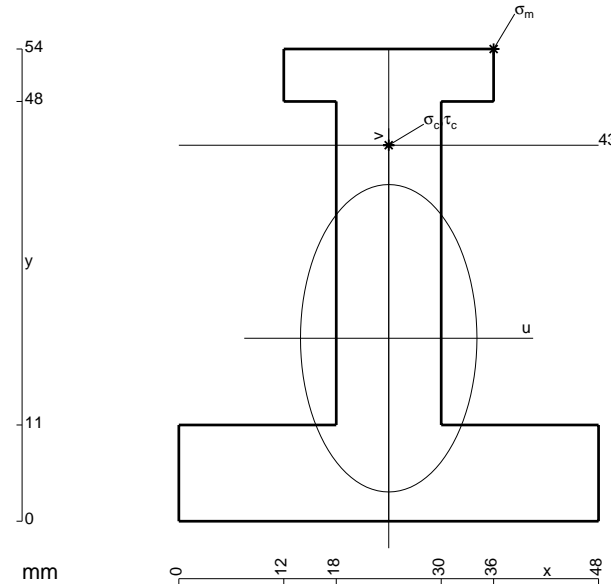

- A = 1116. mm²
- J_u = 344933. mm⁴
- J_v = 113616. mm⁴
- y_g = 20.92 mm
- T_y = -2600. N
- M_x = -2496000. Nmm
- x_m = 36. mm
- y_m = 54. mm
- u_m = 12. mm
- v_m = 33.08 mm
- σ_m = -Mv/J_u = 239.4 N/mm²
- x_c = 24. mm
- y_c = 43. mm
- v_c = 22.08 mm
- σ_c = -Mv/J_u = 159.8 N/mm²
- τ_c = 3.647 N/mm²
- σ_o = √σ_c² + 3τ_c² = 159.9 N/mm²
- S = 5806. mm³

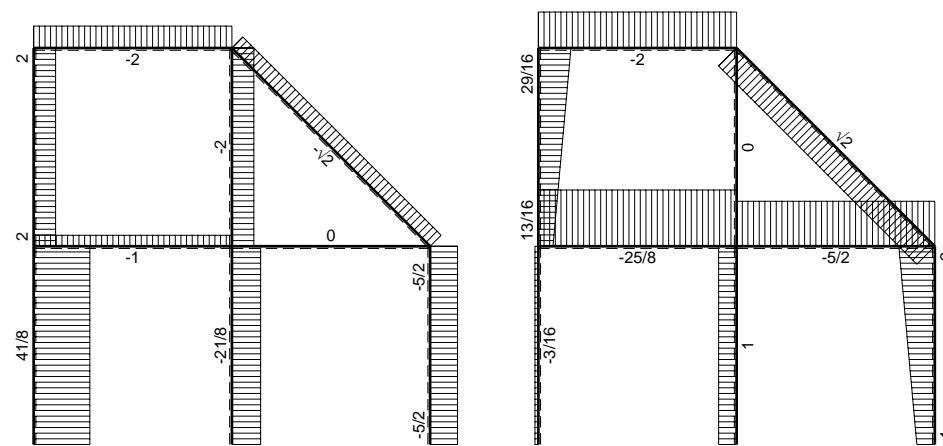
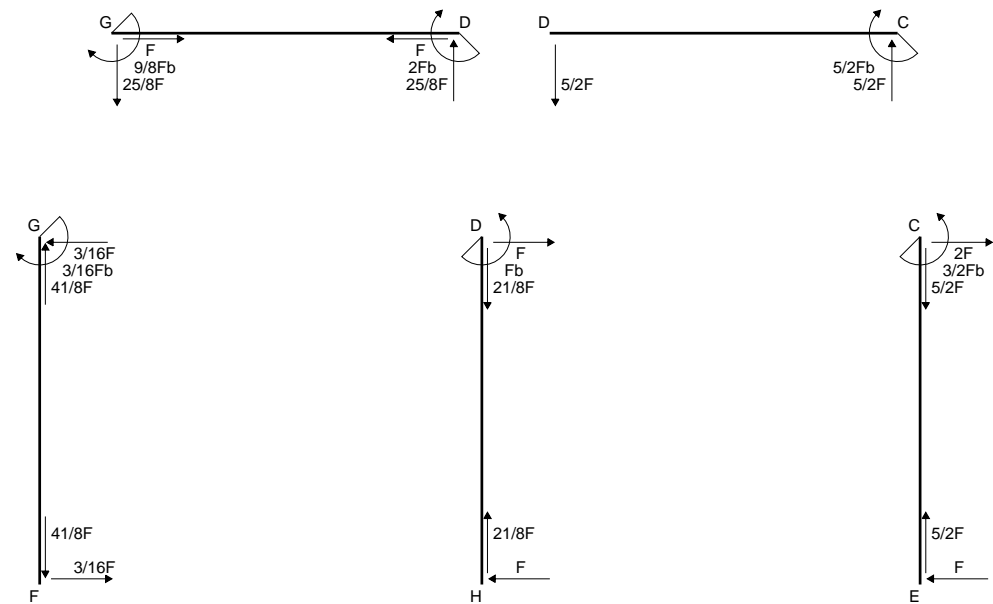
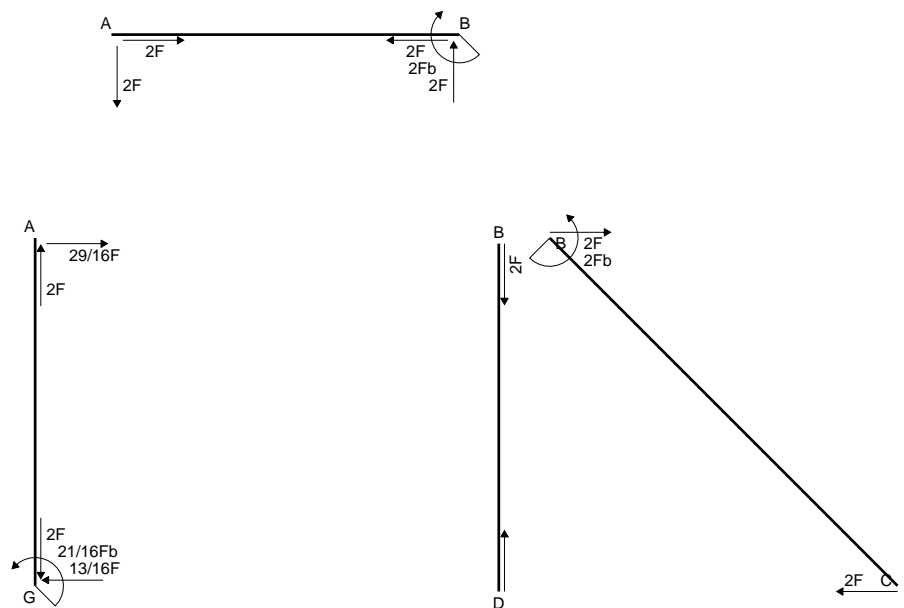

← ⊕ → F

↑ ⊕ ↓ F

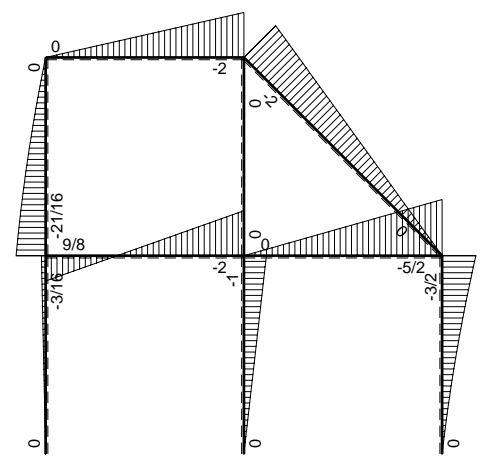

⊕ ⊖ F_b

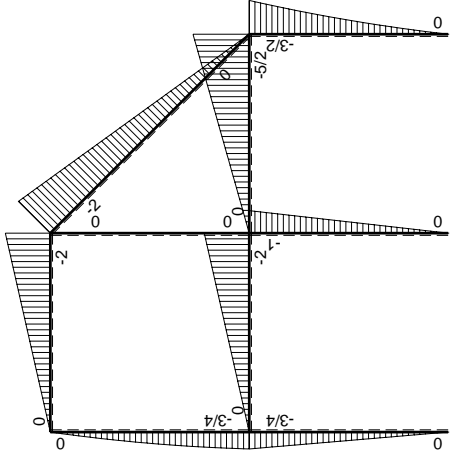
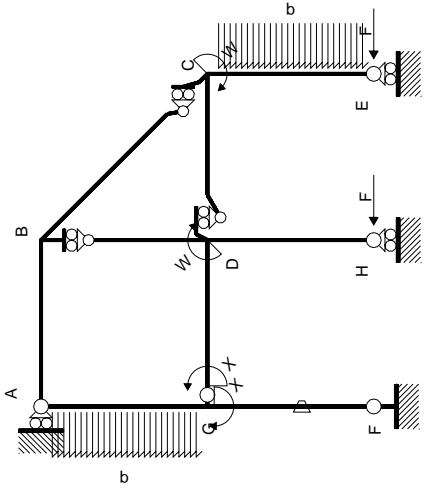

Schema di calcolo iperstatico

M_0 flessione da carichi assegnati

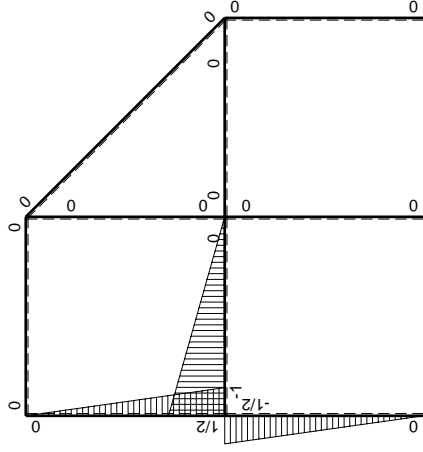

M_x flessione da iperstatica $X=1$

Quadro contributi PLV per iperstatica $X=W_{GD}$

→	$M_x(x)$	$M_o(x)$	θ	$M_x M_o$	$M_x \theta$	$M_x M_x$	$\int M_x(M_o/EJ+\theta)dx$	$\int X M_x M_x/EJdx$
AB b	0	-2Fx	0	0	0	0	0+0	0
BA b	0	2Fb-2Fx	0	0	0	0	0	0
BC $\sqrt{2}b$	0	-2Fb+ $\sqrt{2}Fx$	0	0	0	0	0	0
BD b	0	0	0	0	0	0	0+0	0
DB b	0	0	0	0	0	0	0	0
DC b	0	-5/2Fx	0	0	0	0	0+0	0
CD b	0	5/2Fb-5/2Fx	0	0	0	0	0	0
CE b	0	-3/2Fb+2Fx-1/2qx ²	0	0	0	0	0+0	0
EC b	0	Fx+1/2qx ²	0	0	0	0	0	0
FG b	-1/2x/b	-3/4Fx	-Fb/EJ	3/8Fx ² /b	1/2Fx/EJ	1/4x ² /b ²	(1/8+1/4)Fb ² /EJ	1/12Xb/EJ
GF b	1/2-1/2x/b	3/4Fb-3/4Fx	Fb/EJ	3/8Fb-3/4Fx+3/8Fx ² /b	1/2Fb/EJ-1/2Fx/EJ	1/4-1/2x/b+1/4x ² /b ²		
GD b	-1+x/b	-2Fx	0	2Fx-2Fx ² /b	0	1-2x/b+x ² /b ²	(1/3+0)Fb ² /EJ	1/3Xb/EJ
DG b	x/b	2Fb-2Fx	0	2Fx-2Fx ² /b	0	x ² /b ²		
DH b	0	-Fb+Fx	0	0	0	0	0+0	0
HD b	0	Fx	0	0	0	0		
GA b	1/2-1/2x/b	-3/4Fb+1/4Fx+1/2qx ²	0	-3/8Fb+1/2Fx+1/8Fx ² /b-1/4qx ³ /b	0	1/4-1/2x/b+1/4x ² /b ²	(-7/48+0)Fb ² /EJ	1/12Xb/EJ
AG b	-1/2x/b	5/4Fx-1/2qx ²	0	-5/8Fx ² /b+1/4qx ³ /b	0	1/4x ² /b ²		
	totali						9/16Fb ² /EJ	1/2Xb/EJ
	iperstatica $X=W_{GD}$						-9/8Fb	

Sviluppi di calcolo iperstatica

$$L_{FG}^{xx} = \int_0^b (1/4 x^2/b^2) 1/EJ dx = [1/12 x^3/b^2]_0^b 1/EJ$$

$$= (1/12 b) 1/EJ = 1/12 b/EJ$$

$$L_{GF}^{xx} = \int_0^b (1/4 - 1/2 x/b + 1/4 x^2/b^2) 1/EJ dx = [1/4 x - 1/4 x^2/b + 1/12 x^3/b^2]_0^b 1/EJ$$

$$= (1/4 b - 1/4 b + 1/12 b) 1/EJ = 1/12 b/EJ$$

$$L_{GD}^{xx} = \int_0^b (1 - 2 x/b + x^2/b^2) 1/EJ dx = [x - x^2/b + 1/3 x^3/b^2]_0^b 1/EJ$$

$$= (b - b + 1/3 b) 1/EJ = 1/3 b/EJ$$

$$L_{DG}^{xx} = \int_0^b (x^2/b^2) 1/EJ dx = [1/3 x^3/b^2]_0^b 1/EJ$$

$$= (1/3 b) 1/EJ = 1/3 b/EJ$$

$$L_{GA}^{xx} = \int_0^b (1/4 - 1/2 x/b + 1/4 x^2/b^2) 1/EJ dx = [1/4 x - 1/4 x^2/b + 1/12 x^3/b^2]_0^b 1/EJ$$

$$= (1/4 b - 1/4 b + 1/12 b) 1/EJ = 1/12 b/EJ$$

$$L_{AG}^{xx} = \int_0^b (1/4 x^2/b^2) 1/EJ dx = [1/12 x^3/b^2]_0^b 1/EJ$$

$$= (1/12 b) 1/EJ = 1/12 b/EJ$$

$$L_{FG}^{xo} = \int_0^b (3/8 x^2/b^2) Fb 1/EJ dx + \int_0^b (1/2 x/b) \theta dx = [1/8 x^3/b^2]_0^b Fb 1/EJ + [1/4 x^2/b]_0^b \theta$$

$$= (1/8 b) Fb 1/EJ + (1/4 b) \theta = 3/8 Fb^2/EJ$$

$$L_{GF}^{xo} = \int_0^b (3/8 - 3/4 x/b + 3/8 x^2/b^2) Fb 1/EJ dx + \int_0^b (-1/2 + 1/2 x/b) \theta dx$$

$$= [3/8 x - 3/8 x^2/b + 1/8 x^3/b^2]_0^b Fb 1/EJ + [-1/2 x + 1/4 x^2/b]_0^b \theta$$

$$= (3/8 b - 3/8 b + 1/8 b) Fb 1/EJ + (-1/2 b + 1/4 b) \theta = 3/8 Fb^2/EJ$$

$$L_{GD}^{xo} = \int_0^b (2 x/b - 2 x^2/b^2) Fb 1/EJ dx = [x^2/b - 2/3 x^3/b^2]_0^b Fb 1/EJ$$

$$= (b - 2/3 b) Fb 1/EJ = 1/3 Fb^2/EJ$$

$$L_{DG}^{xo} = \int_0^b (2 x/b - 2 x^2/b^2) Fb 1/EJ dx = [x^2/b - 2/3 x^3/b^2]_0^b Fb 1/EJ$$

$$= (b - 2/3 b) Fb 1/EJ = 1/3 Fb^2/EJ$$

$$L_{GA}^{xo} = \int_0^b (-3/8 + 1/2 x/b + 1/8 x^2/b^2 - 1/4 x^3/b^3) Fb 1/EJ dx$$

$$= [-3/8 x + 1/4 x^2/b + 1/24 x^3/b^2 - 1/16 x^4/b^3]_0^b Fb 1/EJ$$

$$= (-3/8 b + 1/4 b + 1/24 b - 1/16 b) Fb 1/EJ = -7/48 Fb^2/EJ$$

$$L_{AG}^{xo} = \int_0^b (-5/8 x^2/b^2 + 1/4 x^3/b^3) Fb 1/EJ dx = [-5/24 x^3/b^2 + 1/16 x^4/b^3]_0^b Fb 1/EJ$$

$$= (-5/24 b + 1/16 b) Fb 1/EJ = -7/48 Fb^2/EJ$$

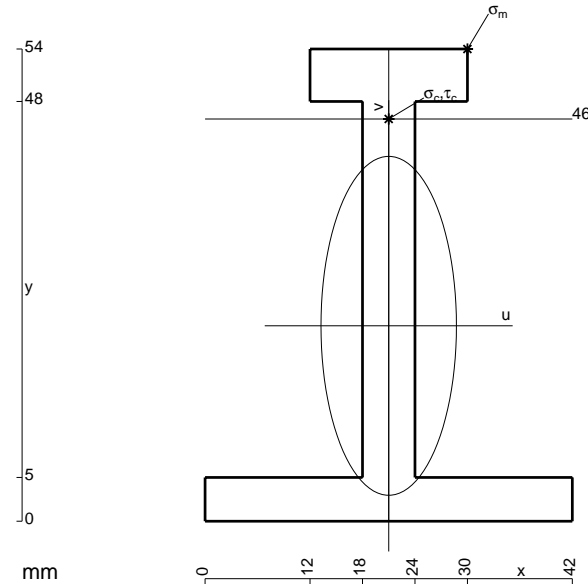

- A = 576. mm²
- J_u = 216352. mm⁴
- J_v = 34560. mm⁴
- y_g = 22.34 mm
- T_y = -2675. N
- M_x = -1364250. Nmm
- x_m = 30. mm
- y_m = 54. mm
- u_m = 9. mm
- v_m = 31.66 mm
- σ_m = -Mv/J_u = 199.6 N/mm²
- x_c = 21. mm
- y_c = 46. mm
- v_c = 23.66 mm
- σ_c = -Mv/J_u = 149.2 N/mm²
- τ_c = 6.987 N/mm²
- σ_o = √σ²+3τ² = 149.7 N/mm²
- S = 3391. mm³

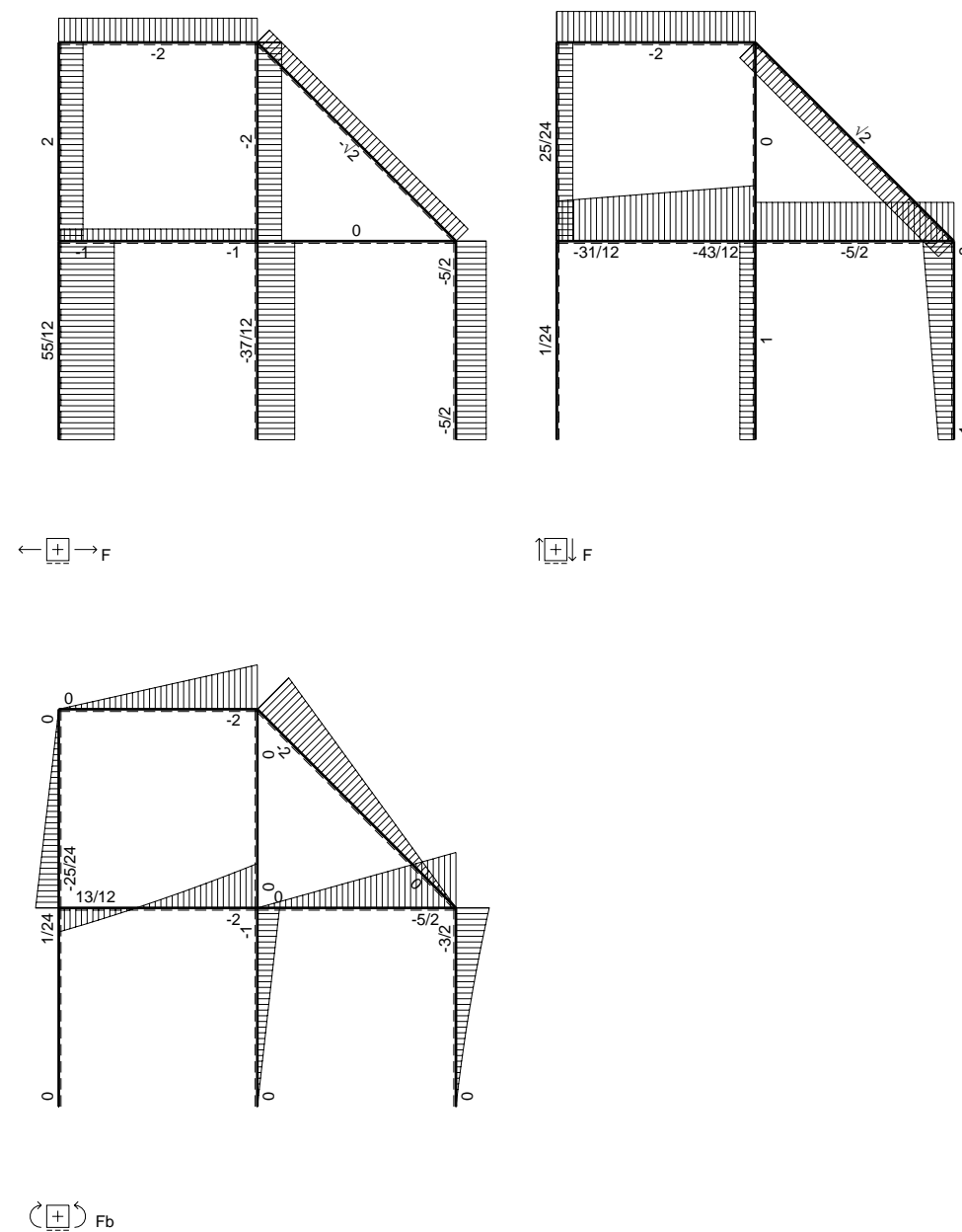
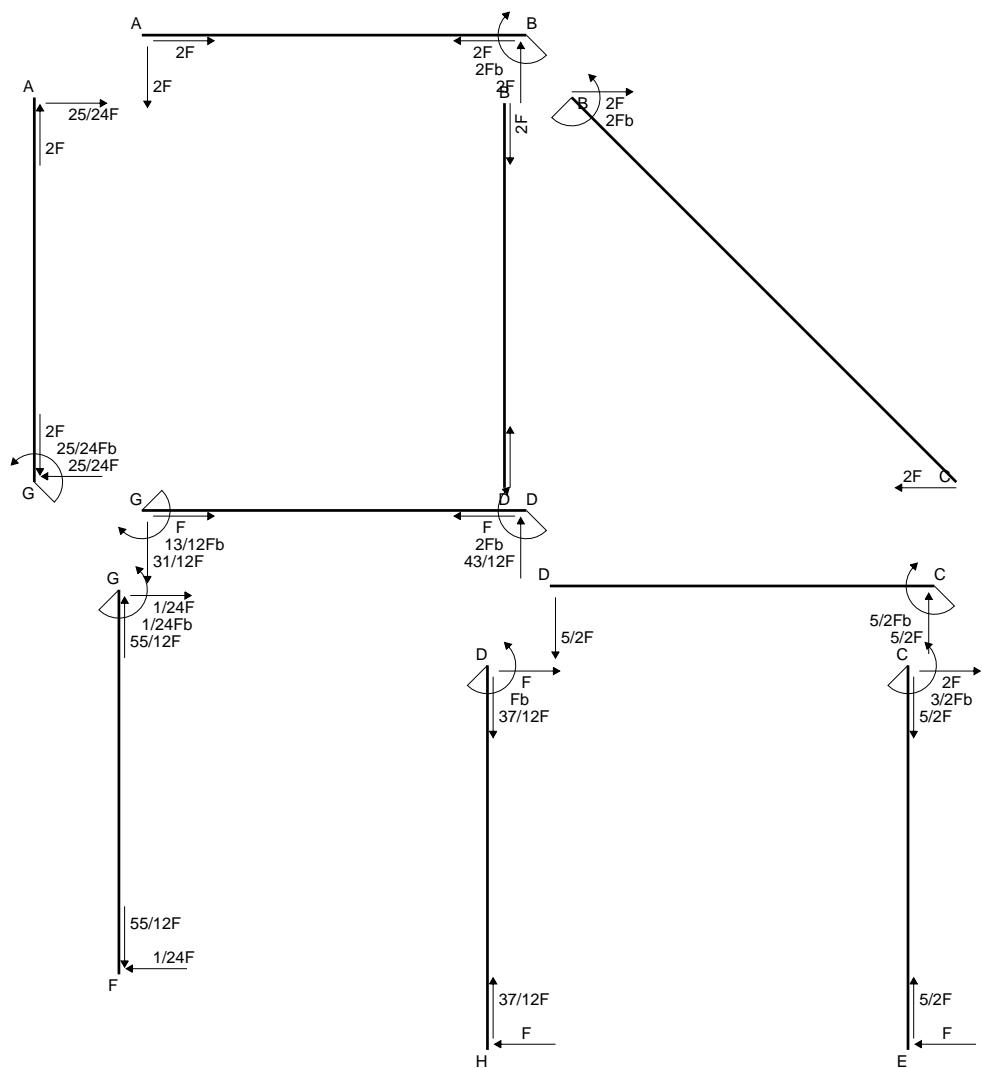

Quadro contributi PLV per iperstatica $X=W_{GD}$

→	$M_x(x)$	$M_o(x)$	θ	$M_x M_o$	$M_x \theta$	$M_x M_x$	$\int M_x(M_o/EJ+\theta)dx$	$\int X M_x M_x/EJ dx$	
AB b	0	-2Fx	0	0	0	0	0+0	0	
BA b	0	2Fb-2Fx	0	0	0	0			
BC $\sqrt{2}b$	0	-2Fb+ $\sqrt{2}Fx$	0	0	0	0	0	0	
BD b	0	0	0	0	0	0	0+0	0	
DB b	0	0	0	0	0	0			
DC b	0	-5/2Fx	0	0	0	0	0+0	0	
CD b	0	5/2Fb-5/2Fx	0	0	0	0			
CE b	0	-3/2Fb+2Fx-1/2qx ²	0	0	0	0	0+0	0	
EC b	0	Fx+1/2qx ²	0	0	0	0			
FG b	-1/2x/b	-1/2Fx	-Fb/EJ	1/4Fx ² /b	1/2Fx/EJ	1/4x ² /b ²	(1/12+1/4)Fb ² /EJ	1/12Xb/EJ	
GF b	1/2-1/2x/b	1/2Fb-1/2Fx	Fb/EJ	1/4Fb-1/2Fx+1/4Fx ² /b	1/2Fb/EJ-1/2Fx/EJ	1/4-1/2x/b+1/4x ² /b ²			
GD b	-1+x/b	-3/2Fx-1/2qx ²	0	3/2Fx-Fx ² /b-1/2qx ³ /b	0	1-2x/b+x ² /b ²	(7/24+0)Fb ² /EJ	1/3Xb/EJ	
DG b	x/b	2Fb-5/2Fx+1/2qx ²	0	2Fx-5/2Fx ² /b+1/2qx ³ /b	0	x ² /b ²			
DH b	0	-Fb+Fx	0	0	0	0	0+0	0	
HD b	0	Fx	0	0	0	0			
GA b	1/2-1/2x/b	-1/2Fb+1/2Fx	0	-1/4Fb+1/2Fx-1/4Fx ² /b	0	1/4-1/2x/b+1/4x ² /b ²	(-1/12+0)Fb ² /EJ	1/12Xb/EJ	
AG b	-1/2x/b	1/2Fx	0	-1/4Fx ² /b	0	1/4x ² /b ²			
	totali							13/24Fb ² /EJ	1/2Xb/EJ
	iperstatica $X=W_{GD}$							-13/12Fb	

Sviluppi di calcolo iperstatica

$$L_{FG}^{xx} = \int_0^b (1/4 x^2/b^2) 1/EJ dx = [1/12 x^3/b^2]_0^b 1/EJ$$

$$= (1/12 b) 1/EJ = 1/12 b/EJ$$

$$L_{GF}^{xx} = \int_0^b (1/4 - 1/2 x/b + 1/4 x^2/b^2) 1/EJ dx = [1/4 x - 1/4 x^2/b + 1/12 x^3/b^2]_0^b 1/EJ$$

$$= (1/4 b - 1/4 b + 1/12 b) 1/EJ = 1/12 b/EJ$$

$$L_{GD}^{xx} = \int_0^b (1 - 2 x/b + x^2/b^2) 1/EJ dx = [x - x^2/b + 1/3 x^3/b^2]_0^b 1/EJ$$

$$= (b - b + 1/3 b) 1/EJ = 1/3 b/EJ$$

$$L_{DG}^{xx} = \int_0^b (x^2/b^2) 1/EJ dx = [1/3 x^3/b^2]_0^b 1/EJ$$

$$= (1/3 b) 1/EJ = 1/3 b/EJ$$

$$L_{GA}^{xx} = \int_0^b (1/4 - 1/2 x/b + 1/4 x^2/b^2) 1/EJ dx = [1/4 x - 1/4 x^2/b + 1/12 x^3/b^2]_0^b 1/EJ$$

$$= (1/4 b - 1/4 b + 1/12 b) 1/EJ = 1/12 b/EJ$$

$$L_{AG}^{xx} = \int_0^b (1/4 x^2/b^2) 1/EJ dx = [1/12 x^3/b^2]_0^b 1/EJ$$

$$= (1/12 b) 1/EJ = 1/12 b/EJ$$

$$L_{FG}^{xo} = \int_0^b (1/4 x^2/b^2) Fb 1/EJ dx + \int_0^b (1/2 x/b) \theta dx = [1/12 x^3/b^2]_0^b Fb 1/EJ + [1/4 x^2/b]_0^b \theta$$

$$= (1/12 b) Fb 1/EJ + (1/4 b) \theta = 1/3 Fb^2/EJ$$

$$L_{GF}^{xo} = \int_0^b (1/4 - 1/2 x/b + 1/4 x^2/b^2) Fb 1/EJ dx + \int_0^b (-1/2 + 1/2 x/b) \theta dx$$

$$= [1/4 x - 1/4 x^2/b + 1/12 x^3/b^2]_0^b Fb 1/EJ + [-1/2 x + 1/4 x^2/b]_0^b \theta$$

$$= (1/4 b - 1/4 b + 1/12 b) Fb 1/EJ + (-1/2 b + 1/4 b) \theta = 1/3 Fb^2/EJ$$

$$L_{GD}^{xo} = \int_0^b (3/2 x/b - x^2/b^2 - 1/2 x^3/b^3) Fb 1/EJ dx = [3/4 x^2/b - 1/3 x^3/b^2 - 1/8 x^4/b^3]_0^b Fb 1/EJ$$

$$= (3/4 b - 1/3 b - 1/8 b) Fb 1/EJ = 7/24 Fb^2/EJ$$

$$L_{DG}^{xo} = \int_0^b (2 x/b - 5/2 x^2/b^2 + 1/2 x^3/b^3) Fb 1/EJ dx = [x^2/b - 5/6 x^3/b^2 + 1/8 x^4/b^3]_0^b Fb 1/EJ$$

$$= (b - 5/6 b + 1/8 b) Fb 1/EJ = 7/24 Fb^2/EJ$$

$$L_{GA}^{xo} = \int_0^b (-1/4 + 1/2 x/b - 1/4 x^2/b^2) Fb 1/EJ dx = [-1/4 x + 1/4 x^2/b - 1/12 x^3/b^2]_0^b Fb 1/EJ$$

$$= (-1/4 b + 1/4 b - 1/12 b) Fb 1/EJ = -1/12 Fb^2/EJ$$

$$L_{AG}^{xo} = \int_0^b (-1/4 x^2/b^2) Fb 1/EJ dx = [-1/12 x^3/b^2]_0^b Fb 1/EJ$$

$$= (-1/12 b) Fb 1/EJ = -1/12 Fb^2/EJ$$

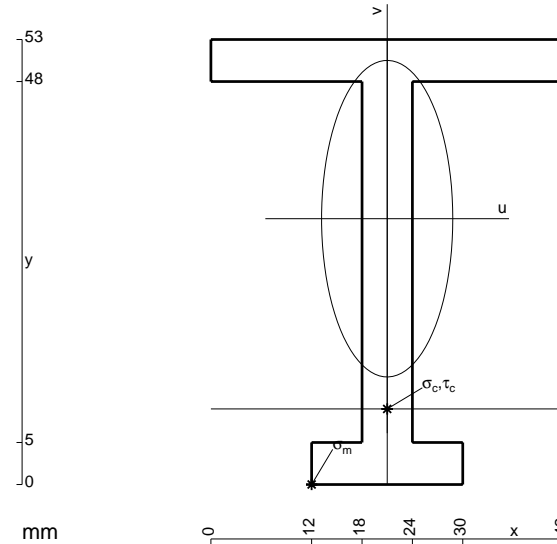

- A = 558. mm²
- J_u = 198314. mm⁴
- J_v = 34074. mm⁴
- y_g = 31.66 mm
- T_y = -2375. N
- M_x = -1306250. Nmm
- x_m = 12. mm
- u_m = -9. mm
- v_m = -31.66 mm
- σ_m = -Mv/J_u = -208.5 N/mm²
- x_c = 21. mm
- y_c = 9. mm
- v_c = -22.66 mm
- σ_c = -Mv/J_u = -149.3 N/mm²
- τ_c = 6.42 N/mm²
- σ_o = √σ²+3τ² = 149.7 N/mm²
- S = 3216. mm³

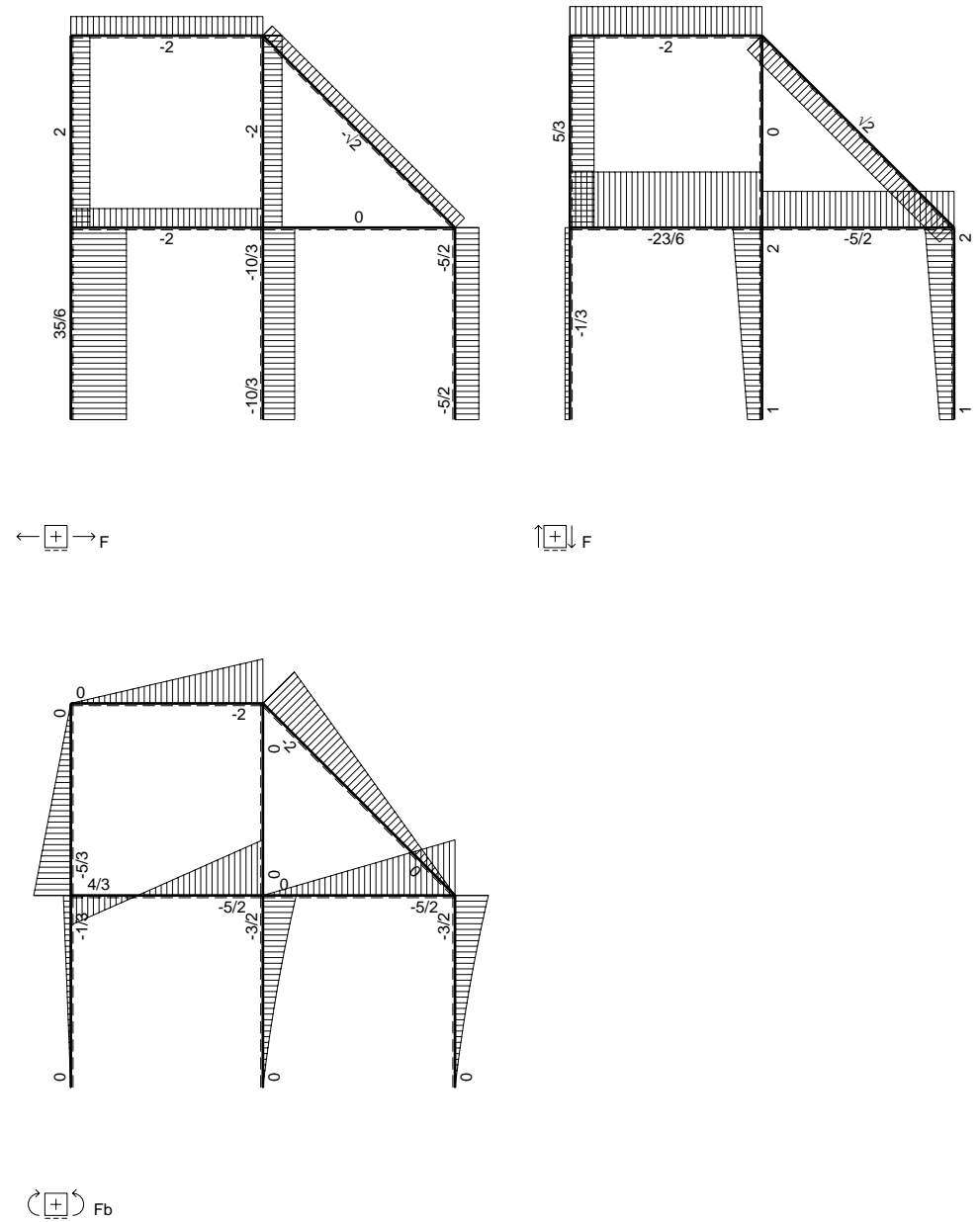
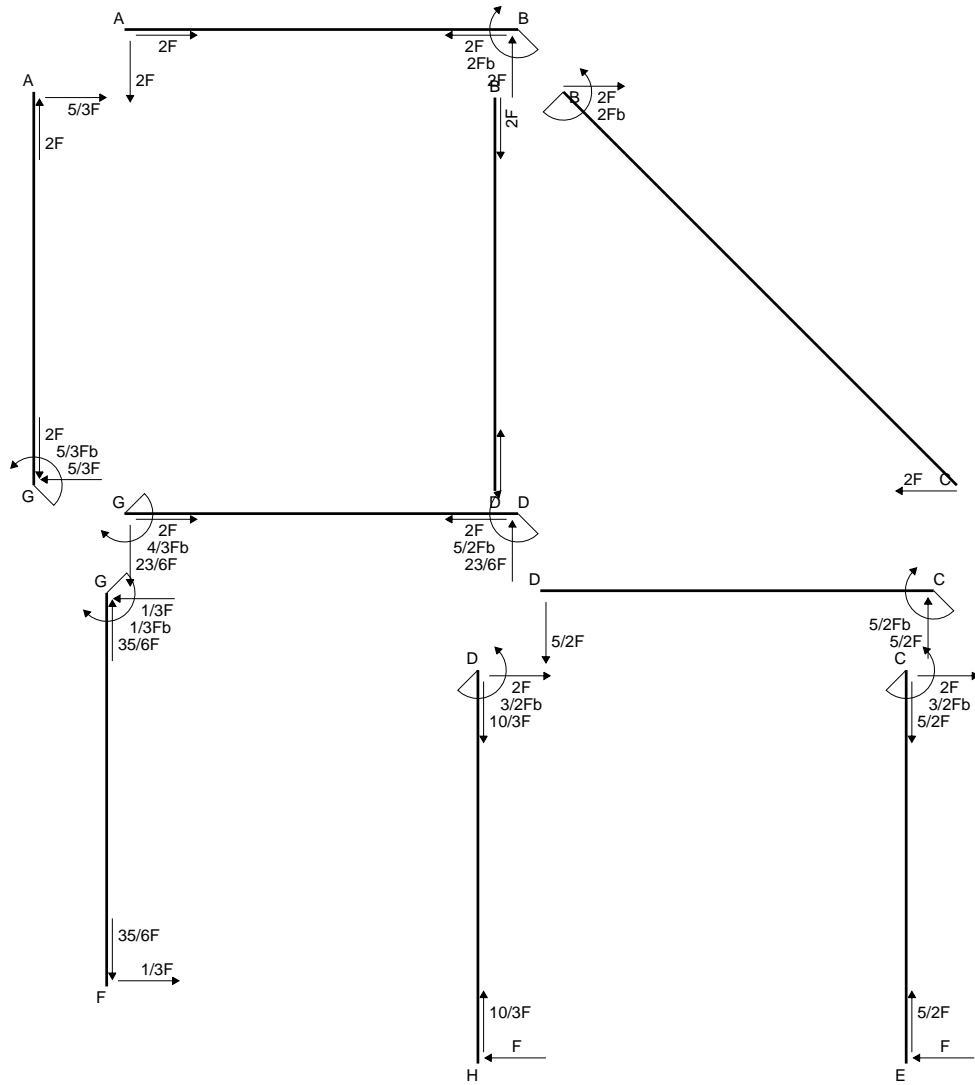

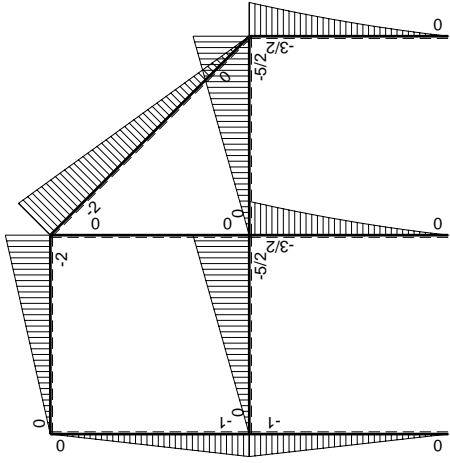
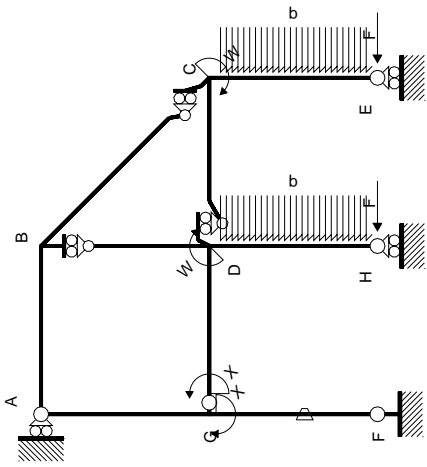

Schema di calcolo iperstatico

M_0 flessione da carichi assegnati

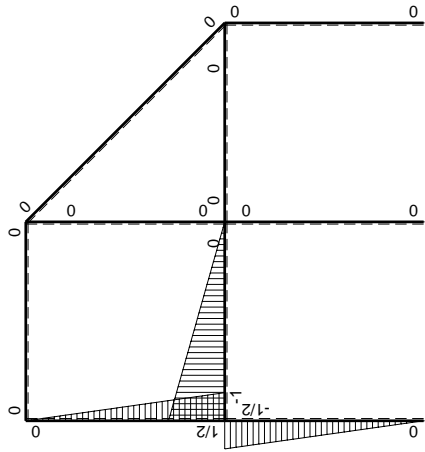

M_x flessione da iperstatica $X=1$

Quadro contributi PLV per iperstatica $X=W_{GD}$

→	$M_x(x)$	$M_o(x)$	θ	$M_x M_o$	$M_x \theta$	$M_x M_x$	$\int M_x(M_o/EJ+\theta)dx$	$\int X M_x M_x / EJ dx$	
AB b	0	-2Fx	0	0	0	0	0+0	0	
BA b	0	2Fb-2Fx	0	0	0	0	0	0	
BC $\sqrt{2}b$	0	-2Fb+ $\sqrt{2}Fx$	0	0	0	0	0	0	
BD b	0	0	0	0	0	0	0+0	0	
DB b	0	0	0	0	0	0	0	0	
DC b	0	-5/2Fx	0	0	0	0	0+0	0	
CD b	0	5/2Fb-5/2Fx	0	0	0	0	0	0	
CE b	0	-3/2Fb+2Fx-1/2qx ²	0	0	0	0	0+0	0	
EC b	0	Fx+1/2qx ²	0	0	0	0	0	0	
FG b	-1/2x/b	-Fx	-Fb/EJ	1/2Fx ² /b	1/2Fx/EJ	1/4x ² /b ²	(1/6+1/4)Fb ² /EJ	1/12Xb/EJ	
GF b	1/2-1/2x/b	Fb-Fx	Fb/EJ	1/2Fb-Fx+1/2Fx ² /b	1/2Fb/EJ-1/2Fx/EJ	1/4-1/2x/b+1/4x ² /b ²			
GD b	-1+x/b	-5/2Fx	0	5/2Fx-5/2Fx ² /b	0	1-2x/b+x ² /b ²	(5/12+0)Fb ² /EJ	1/3Xb/EJ	
DG b	x/b	5/2Fb-5/2Fx	0	5/2Fx-5/2Fx ² /b	0	x ² /b ²			
DH b	0	-3/2Fb+2Fx-1/2qx ²	0	0	0	0	0+0	0	
HD b	0	Fx+1/2qx ²	0	0	0	0	0	0	
GA b	1/2-1/2x/b	-Fb+Fx	0	-1/2Fb+Fx-1/2Fx ² /b	0	1/4-1/2x/b+1/4x ² /b ²	(-1/6+0)Fb ² /EJ	1/12Xb/EJ	
AG b	-1/2x/b	Fx	0	-1/2Fx ² /b	0	1/4x ² /b ²			
	totali							2/3Fb ² /EJ	1/2Xb/EJ
	iperstatica $X=W_{GD}$							-4/3Fb	

Sviluppi di calcolo iperstatica

$$L_{FG}^{xx} = \int_0^b (1/4 x^2/b^2) 1/EJ dx = [1/12 x^3/b^2]_0^b 1/EJ$$

$$= (1/12 b) 1/EJ = 1/12 b/EJ$$

$$L_{GF}^{xx} = \int_0^b (1/4 - 1/2 x/b + 1/4 x^2/b^2) 1/EJ dx = [1/4 x - 1/4 x^2/b + 1/12 x^3/b^2]_0^b 1/EJ$$

$$= (1/4 b - 1/4 b + 1/12 b) 1/EJ = 1/12 b/EJ$$

$$L_{GD}^{xx} = \int_0^b (1 - 2 x/b + x^2/b^2) 1/EJ dx = [x - x^2/b + 1/3 x^3/b^2]_0^b 1/EJ$$

$$= (b - b + 1/3 b) 1/EJ = 1/3 b/EJ$$

$$L_{DG}^{xx} = \int_0^b (x^2/b^2) 1/EJ dx = [1/3 x^3/b^2]_0^b 1/EJ$$

$$= (1/3 b) 1/EJ = 1/3 b/EJ$$

$$L_{GA}^{xx} = \int_0^b (1/4 - 1/2 x/b + 1/4 x^2/b^2) 1/EJ dx = [1/4 x - 1/4 x^2/b + 1/12 x^3/b^2]_0^b 1/EJ$$

$$= (1/4 b - 1/4 b + 1/12 b) 1/EJ = 1/12 b/EJ$$

$$L_{AG}^{xx} = \int_0^b (1/4 x^2/b^2) 1/EJ dx = [1/12 x^3/b^2]_0^b 1/EJ$$

$$= (1/12 b) 1/EJ = 1/12 b/EJ$$

$$L_{FG}^{xo} = \int_0^b (1/2 x^2/b^2) Fb 1/EJ dx + \int_0^b (1/2 x/b) \theta dx = [1/6 x^3/b^2]_0^b Fb 1/EJ + [1/4 x^2/b]_0^b \theta$$

$$= (1/6 b) Fb 1/EJ + (1/4 b) \theta = 5/12 Fb^2/EJ$$

$$L_{GF}^{xo} = \int_0^b (1/2 - x/b + 1/2 x^2/b^2) Fb 1/EJ dx + \int_0^b (-1/2 + 1/2 x/b) \theta dx$$

$$= [1/2 x - 1/2 x^2/b + 1/6 x^3/b^2]_0^b Fb 1/EJ + [-1/2 x + 1/4 x^2/b]_0^b \theta$$

$$= (1/2 b - 1/2 b + 1/6 b) Fb 1/EJ + (-1/2 b + 1/4 b) \theta = 5/12 Fb^2/EJ$$

$$L_{GD}^{xo} = \int_0^b (5/2 x/b - 5/2 x^2/b^2) Fb 1/EJ dx = [5/4 x^2/b - 5/6 x^3/b^2]_0^b Fb 1/EJ$$

$$= (5/4 b - 5/6 b) Fb 1/EJ = 5/12 Fb^2/EJ$$

$$L_{DG}^{xo} = \int_0^b (5/2 x/b - 5/2 x^2/b^2) Fb 1/EJ dx = [5/4 x^2/b - 5/6 x^3/b^2]_0^b Fb 1/EJ$$

$$= (5/4 b - 5/6 b) Fb 1/EJ = 5/12 Fb^2/EJ$$

$$L_{GA}^{xo} = \int_0^b (-1/2 + x/b - 1/2 x^2/b^2) Fb 1/EJ dx = [-1/2 x + 1/2 x^2/b - 1/6 x^3/b^2]_0^b Fb 1/EJ$$

$$= (-1/2 b + 1/2 b - 1/6 b) Fb 1/EJ = -1/6 Fb^2/EJ$$

$$L_{AG}^{xo} = \int_0^b (-1/2 x^2/b^2) Fb 1/EJ dx = [-1/6 x^3/b^2]_0^b Fb 1/EJ$$

$$= (-1/6 b) Fb 1/EJ = -1/6 Fb^2/EJ$$

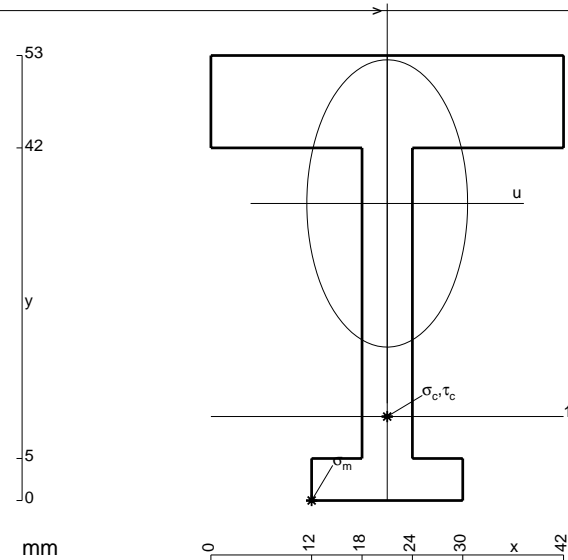

$$A = 774. \text{ mm}^2$$

$$J_u = 226668. \text{ mm}^4$$

$$J_v = 71010. \text{ mm}^4$$

$$y_g = 35.38 \text{ mm}$$

$$T_y = -2325. \text{ N}$$

$$M_x = -1395000. \text{ Nmm}$$

$$x_m = 12. \text{ mm}$$

$$u_m = -9. \text{ mm}$$

$$v_m = -35.38 \text{ mm}$$

$$\sigma_m = -Mv/J_u = -217.8 \text{ N/mm}^2$$

$$x_c = 21. \text{ mm}$$

$$y_c = 10. \text{ mm}$$

$$v_c = -25.38 \text{ mm}$$

$$\sigma_c = -Mv/J_u = -156.2 \text{ N/mm}^2$$

$$\tau_c = 6.49 \text{ N/mm}^2$$

$$\sigma_o = \sqrt{\sigma^2 + 3\tau^2} = 156.6 \text{ N/mm}^2$$

$$S = 3796. \text{ mm}^3$$

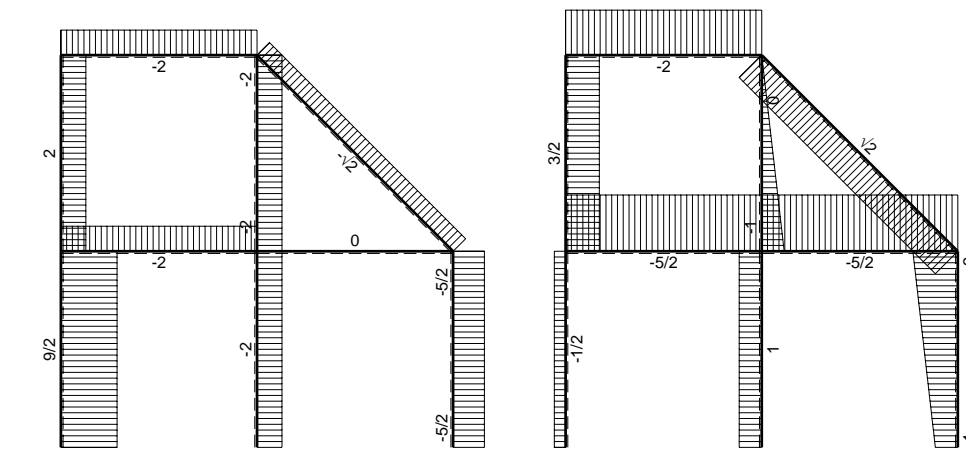
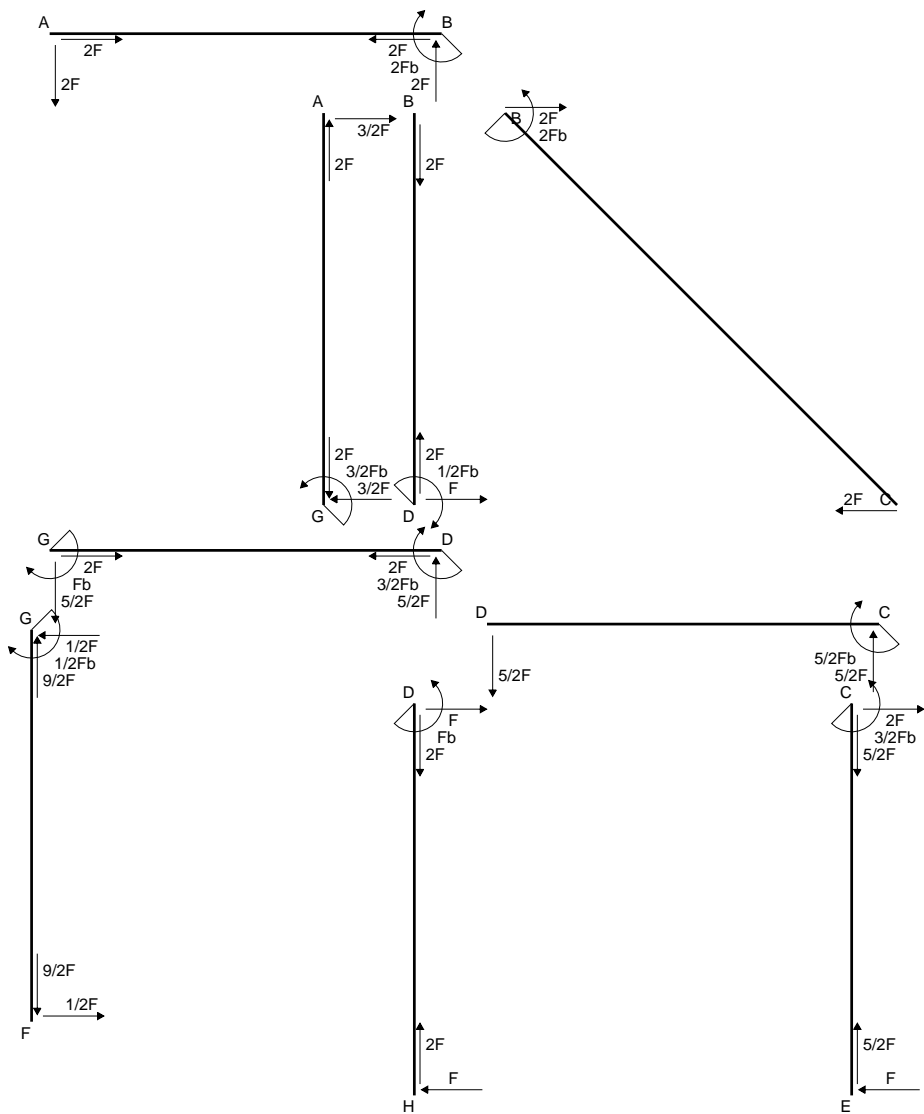

← ⊕ → F

↑ ⊕ ↓ F

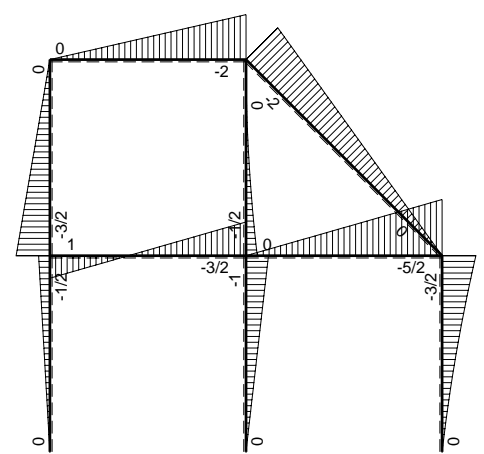

⊕ Fb

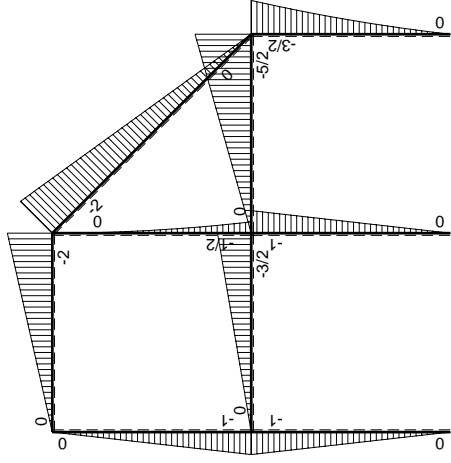
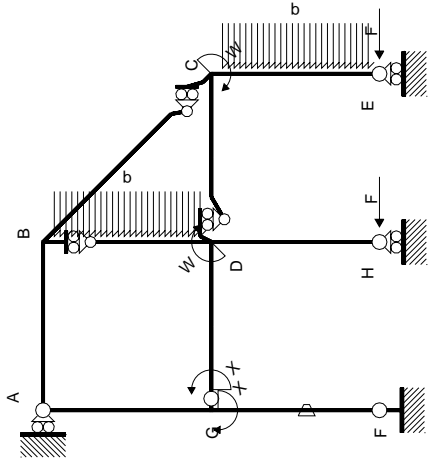

Schema di calcolo iperstatico

M_0 flessione da carichi assegnati

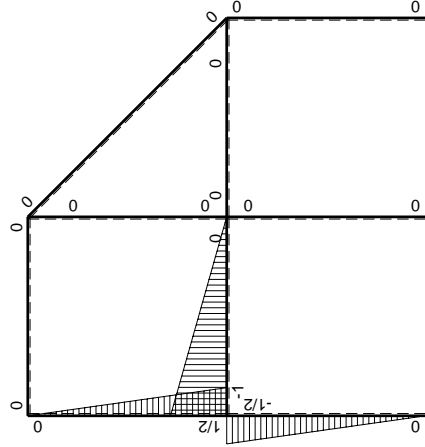

M_x flessione da iperstatica $X=1$

Quadro contributi PLV per iperstatica $X=W_{GD}$

→	$M_x(x)$	$M_o(x)$	θ	$M_x M_o$	$M_x \theta$	$M_x M_x$	$\int M_x(M_o/EJ+\theta)dx$	$\int X M_x M_x/EJdx$
AB b	0	-2Fx	0	0	0	0	0+0	0
BA b	0	2Fb-2Fx	0	0	0	0	0	0
BC $\sqrt{2}b$	0	-2Fb+ $\sqrt{2}Fx$	0	0	0	0	0	0
BD b	0	-1/2qx ²	0	0	0	0	0+0	0
DB b	0	1/2Fb-Fx+1/2qx ²	0	0	0	0	0	0
DC b	0	-5/2Fx	0	0	0	0	0+0	0
CD b	0	5/2Fb-5/2Fx	0	0	0	0	0	0
CE b	0	-3/2Fb+2Fx-1/2qx ²	0	0	0	0	0+0	0
EC b	0	Fx+1/2qx ²	0	0	0	0	0	0
FG b	-1/2x/b	-Fx	-Fb/EJ	1/2Fx ² /b	1/2Fx/EJ	1/4x ² /b ²	(1/6+1/4)Fb ² /EJ	1/12Xb/EJ
GF b	1/2-1/2x/b	Fb-Fx	Fb/EJ	1/2Fb-Fx+1/2Fx ² /b	1/2Fb/EJ-1/2Fx/EJ	1/4-1/2x/b+1/4x ² /b ²		
GD b	-1+x/b	-3/2Fx	0	3/2Fx-3/2Fx ² /b	0	1-2x/b+x ² /b ²	(1/4+0)Fb ² /EJ	1/3Xb/EJ
DG b	x/b	3/2Fb-3/2Fx	0	3/2Fx-3/2Fx ² /b	0	x ² /b ²		
DH b	0	-Fb+Fx	0	0	0	0	0+0	0
HD b	0	Fx	0	0	0	0	0	0
GA b	1/2-1/2x/b	-Fb+Fx	0	-1/2Fb+Fx-1/2Fx ² /b	0	1/4-1/2x/b+1/4x ² /b ²	(-1/6+0)Fb ² /EJ	1/12Xb/EJ
AG b	-1/2x/b	Fx	0	-1/2Fx ² /b	0	1/4x ² /b ²		
	totali						1/2Fb ² /EJ	1/2Xb/EJ
	iperstatica $X=W_{GD}$						-Fb	

Sviluppi di calcolo iperstatica

$$L_{FG}^{xx} = \int_0^b (1/4 x^2/b^2) 1/EJ dx = [1/12 x^3/b^2]_0^b 1/EJ$$

$$= (1/12 b) 1/EJ = 1/12 b/EJ$$

$$L_{GF}^{xx} = \int_0^b (1/4 - 1/2 x/b + 1/4 x^2/b^2) 1/EJ dx = [1/4 x - 1/4 x^2/b + 1/12 x^3/b^2]_0^b 1/EJ$$

$$= (1/4 b - 1/4 b + 1/12 b) 1/EJ = 1/12 b/EJ$$

$$L_{GD}^{xx} = \int_0^b (1 - 2 x/b + x^2/b^2) 1/EJ dx = [x - x^2/b + 1/3 x^3/b^2]_0^b 1/EJ$$

$$= (b - b + 1/3 b) 1/EJ = 1/3 b/EJ$$

$$L_{DG}^{xx} = \int_0^b (x^2/b^2) 1/EJ dx = [1/3 x^3/b^2]_0^b 1/EJ$$

$$= (1/3 b) 1/EJ = 1/3 b/EJ$$

$$L_{GA}^{xx} = \int_0^b (1/4 - 1/2 x/b + 1/4 x^2/b^2) 1/EJ dx = [1/4 x - 1/4 x^2/b + 1/12 x^3/b^2]_0^b 1/EJ$$

$$= (1/4 b - 1/4 b + 1/12 b) 1/EJ = 1/12 b/EJ$$

$$L_{AG}^{xx} = \int_0^b (1/4 x^2/b^2) 1/EJ dx = [1/12 x^3/b^2]_0^b 1/EJ$$

$$= (1/12 b) 1/EJ = 1/12 b/EJ$$

$$L_{FG}^{xo} = \int_0^b (1/2 x^2/b^2) Fb 1/EJ dx + \int_0^b (1/2 x/b) \theta dx = [1/6 x^3/b^2]_0^b Fb 1/EJ + [1/4 x^2/b]_0^b \theta$$

$$= (1/6 b) Fb 1/EJ + (1/4 b) \theta = 5/12 Fb^2/EJ$$

$$L_{GF}^{xo} = \int_0^b (1/2 - x/b + 1/2 x^2/b^2) Fb 1/EJ dx + \int_0^b (-1/2 + 1/2 x/b) \theta dx$$

$$= [1/2 x - 1/2 x^2/b + 1/6 x^3/b^2]_0^b Fb 1/EJ + [-1/2 x + 1/4 x^2/b]_0^b \theta$$

$$= (1/2 b - 1/2 b + 1/6 b) Fb 1/EJ + (-1/2 b + 1/4 b) \theta = 5/12 Fb^2/EJ$$

$$L_{GD}^{xo} = \int_0^b (3/2 x/b - 3/2 x^2/b^2) Fb 1/EJ dx = [3/4 x^2/b - 1/2 x^3/b^2]_0^b Fb 1/EJ$$

$$= (3/4 b - 1/2 b) Fb 1/EJ = 1/4 Fb^2/EJ$$

$$L_{DG}^{xo} = \int_0^b (3/2 x/b - 3/2 x^2/b^2) Fb 1/EJ dx = [3/4 x^2/b - 1/2 x^3/b^2]_0^b Fb 1/EJ$$

$$= (3/4 b - 1/2 b) Fb 1/EJ = 1/4 Fb^2/EJ$$

$$L_{GA}^{xo} = \int_0^b (-1/2 + x/b - 1/2 x^2/b^2) Fb 1/EJ dx = [-1/2 x + 1/2 x^2/b - 1/6 x^3/b^2]_0^b Fb 1/EJ$$

$$= (-1/2 b + 1/2 b - 1/6 b) Fb 1/EJ = -1/6 Fb^2/EJ$$

$$L_{AG}^{xo} = \int_0^b (-1/2 x^2/b^2) Fb 1/EJ dx = [-1/6 x^3/b^2]_0^b Fb 1/EJ$$

$$= (-1/6 b) Fb 1/EJ = -1/6 Fb^2/EJ$$

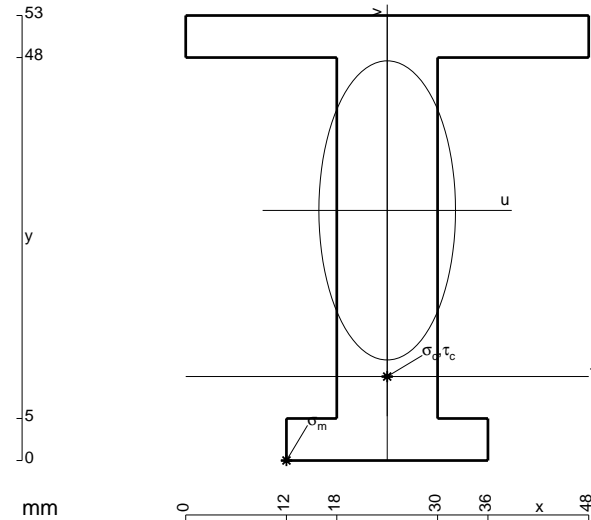

- A = 876. mm²
- J_u = 278148. mm⁴
- J_v = 58032. mm⁴
- y_g = 29.79 mm
- T_y = -3300. N
- M_x = -2145000. Nmm
- x_m = 12. mm
- u_m = -12. mm
- v_m = -29.79 mm
- σ_m = -Mv/J_u = -229.7 N/mm²
- x_c = 24. mm
- y_c = 10. mm
- v_c = -19.79 mm
- σ_c = -Mv/J_u = -152.6 N/mm²
- τ_c = 4.56 N/mm²
- σ_o = √σ²+3τ² = 152.8 N/mm²
- S = 4612. mm³

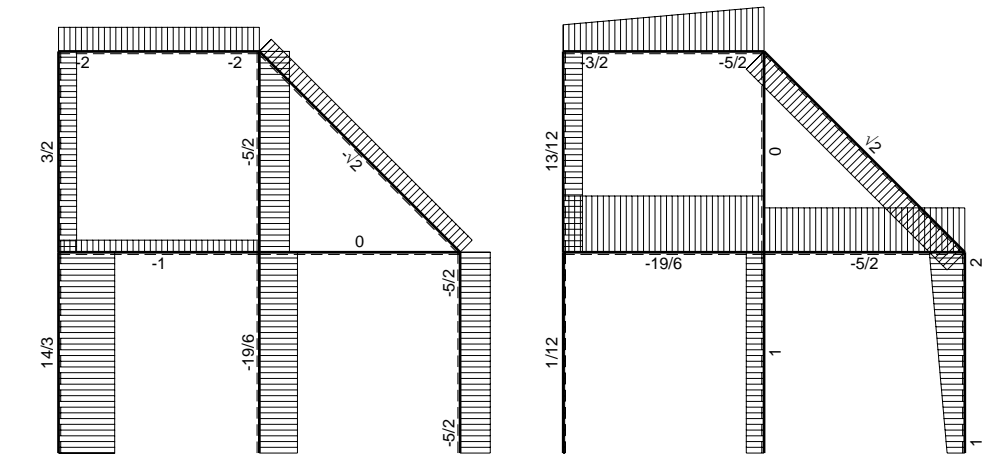
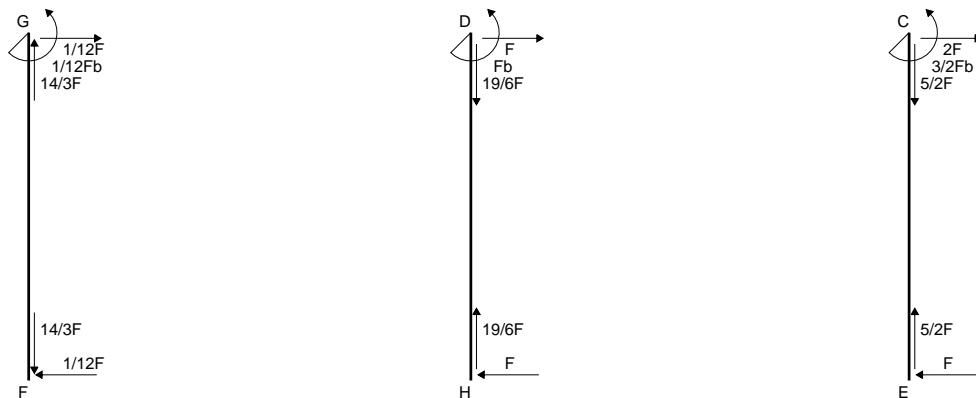
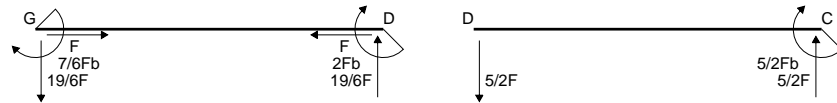
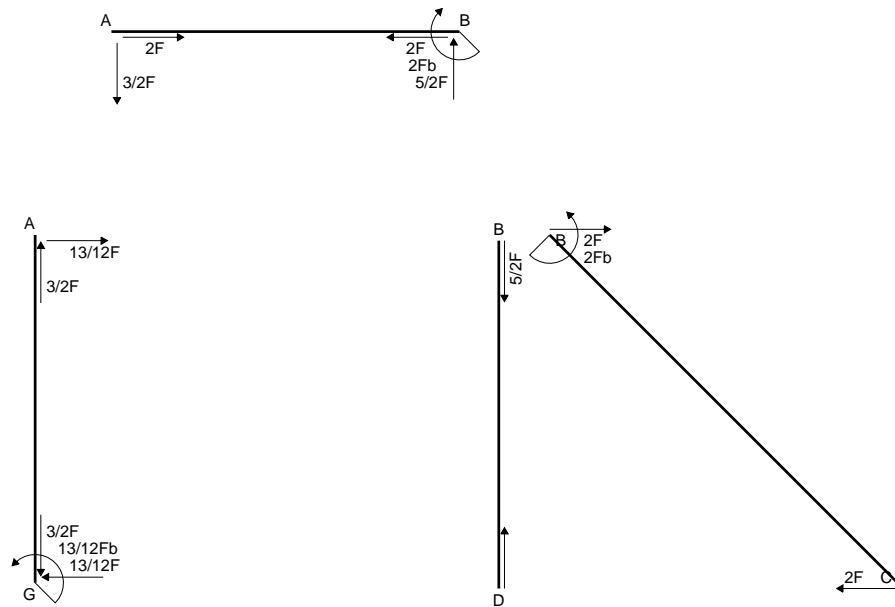

← ⊕ → F

↑ ⊕ ↓ M

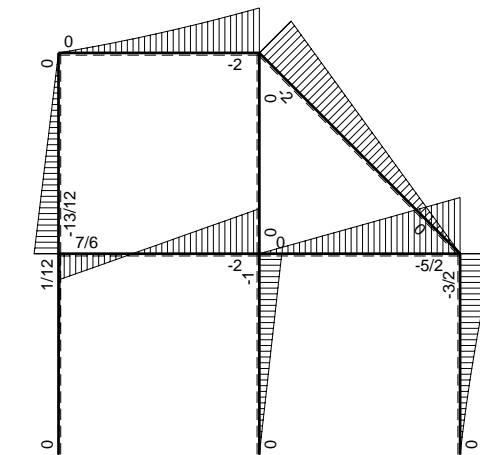

⊕ ⊖ Fb

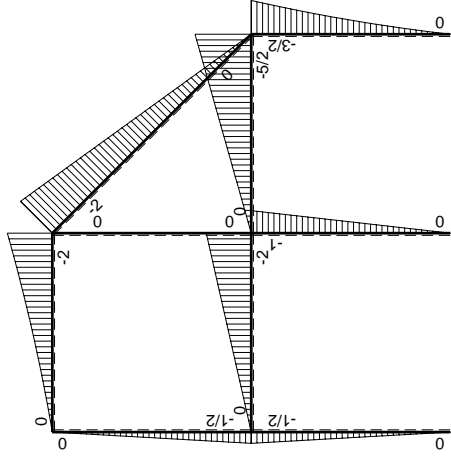
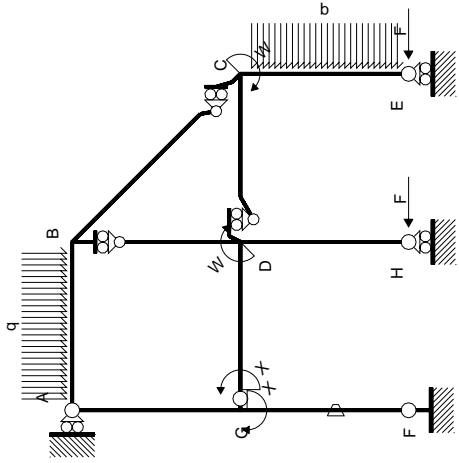

Schema di calcolo iperstatico

M_0 flessione da carichi assegnati

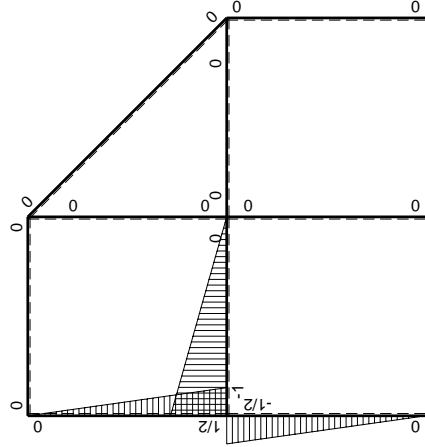

M_x flessione da iperstatica $X=1$

Quadro contributi PLV per iperstatica $X=W_{GD}$

→	$M_x(x)$	$M_o(x)$	θ	$M_x M_o$	$M_x \theta$	$M_x M_x$	$\int M_x(M_o/EJ+\theta)dx$	$\int X M_x M_x/EJ dx$	
AB b	0	$-3/2Fx-1/2qx^2$	0	0	0	0	0+0	0	
BA b	0	$2Fb-5/2Fx+1/2qx^2$	0	0	0	0			
BC $\sqrt{2}b$	0	$-2Fb+\sqrt{2}Fx$	0	0	0	0	0	0	
BD b	0	0	0	0	0	0	0+0	0	
DB b	0	0	0	0	0	0			
DC b	0	$-5/2Fx$	0	0	0	0	0+0	0	
CD b	0	$5/2Fb-5/2Fx$	0	0	0	0			
CE b	0	$-3/2Fb+2Fx-1/2qx^2$	0	0	0	0	0+0	0	
EC b	0	$Fx+1/2qx^2$	0	0	0	0			
FG b	$-1/2x/b$	$-1/2Fx$	$-Fb/EJ$	$1/4Fx^2/b$	$1/2Fx/EJ$	$1/4x^2/b^2$	$(1/12+1/4)Fb^2/EJ$	$1/12Xb/EJ$	
GF b	$1/2-1/2x/b$	$1/2Fb-1/2Fx$	Fb/EJ	$1/4Fb-1/2Fx+1/4Fx^2/b$	$1/2Fb/EJ-1/2Fx/EJ$	$1/4-1/2x/b+1/4x^2/b^2$			
GD b	$-1+x/b$	$-2Fx$	0	$2Fx-2Fx^2/b$	0	$1-2x/b+x^2/b^2$	$(1/3+0)Fb^2/EJ$	$1/3Xb/EJ$	
DG b	x/b	$2Fb-2Fx$	0	$2Fx-2Fx^2/b$	0	x^2/b^2			
DH b	0	$-Fb+Fx$	0	0	0	0	0+0	0	
HD b	0	Fx	0	0	0	0			
GA b	$1/2-1/2x/b$	$-1/2Fb+1/2Fx$	0	$-1/4Fb+1/2Fx-1/4Fx^2/b$	0	$1/4-1/2x/b+1/4x^2/b^2$	$(-1/12+0)Fb^2/EJ$	$1/12Xb/EJ$	
AG b	$-1/2x/b$	$1/2Fx$	0	$-1/4Fx^2/b$	0	$1/4x^2/b^2$			
	totali							$7/12Fb^2/EJ$	$1/2Xb/EJ$
	iperstatica $X=W_{GD}$							$-7/6Fb$	

Sviluppi di calcolo iperstatica

$$L_{FG}^{xx} = \int_0^b (1/4 x^2/b^2) 1/EJ dx = [1/12 x^3/b^2]_0^b 1/EJ$$

$$= (1/12 b) 1/EJ = 1/12 b/EJ$$

$$L_{GF}^{xx} = \int_0^b (1/4 - 1/2 x/b + 1/4 x^2/b^2) 1/EJ dx = [1/4 x - 1/4 x^2/b + 1/12 x^3/b^2]_0^b 1/EJ$$

$$= (1/4 b - 1/4 b + 1/12 b) 1/EJ = 1/12 b/EJ$$

$$L_{GD}^{xx} = \int_0^b (1 - 2 x/b + x^2/b^2) 1/EJ dx = [x - x^2/b + 1/3 x^3/b^2]_0^b 1/EJ$$

$$= (b - b + 1/3 b) 1/EJ = 1/3 b/EJ$$

$$L_{DG}^{xx} = \int_0^b (x^2/b^2) 1/EJ dx = [1/3 x^3/b^2]_0^b 1/EJ$$

$$= (1/3 b) 1/EJ = 1/3 b/EJ$$

$$L_{GA}^{xx} = \int_0^b (1/4 - 1/2 x/b + 1/4 x^2/b^2) 1/EJ dx = [1/4 x - 1/4 x^2/b + 1/12 x^3/b^2]_0^b 1/EJ$$

$$= (1/4 b - 1/4 b + 1/12 b) 1/EJ = 1/12 b/EJ$$

$$L_{AG}^{xx} = \int_0^b (1/4 x^2/b^2) 1/EJ dx = [1/12 x^3/b^2]_0^b 1/EJ$$

$$= (1/12 b) 1/EJ = 1/12 b/EJ$$

$$L_{FG}^{xo} = \int_0^b (1/4 x^2/b^2) Fb 1/EJ dx + \int_0^b (1/2 x/b) \theta dx = [1/12 x^3/b^2]_0^b Fb 1/EJ + [1/4 x^2/b]_0^b \theta$$

$$= (1/12 b) Fb 1/EJ + (1/4 b) \theta = 1/3 Fb^2/EJ$$

$$L_{GF}^{xo} = \int_0^b (1/4 - 1/2 x/b + 1/4 x^2/b^2) Fb 1/EJ dx + \int_0^b (-1/2 + 1/2 x/b) \theta dx$$

$$= [1/4 x - 1/4 x^2/b + 1/12 x^3/b^2]_0^b Fb 1/EJ + [-1/2 x + 1/4 x^2/b]_0^b \theta$$

$$= (1/4 b - 1/4 b + 1/12 b) Fb 1/EJ + (-1/2 b + 1/4 b) \theta = 1/3 Fb^2/EJ$$

$$L_{GD}^{xo} = \int_0^b (2 x/b - 2 x^2/b^2) Fb 1/EJ dx = [x^2/b - 2/3 x^3/b^2]_0^b Fb 1/EJ$$

$$= (b - 2/3 b) Fb 1/EJ = 1/3 Fb^2/EJ$$

$$L_{DG}^{xo} = \int_0^b (2 x/b - 2 x^2/b^2) Fb 1/EJ dx = [x^2/b - 2/3 x^3/b^2]_0^b Fb 1/EJ$$

$$= (b - 2/3 b) Fb 1/EJ = 1/3 Fb^2/EJ$$

$$L_{GA}^{xo} = \int_0^b (-1/4 + 1/2 x/b - 1/4 x^2/b^2) Fb 1/EJ dx = [-1/4 x + 1/4 x^2/b - 1/12 x^3/b^2]_0^b Fb 1/EJ$$

$$= (-1/4 b + 1/4 b - 1/12 b) Fb 1/EJ = -1/12 Fb^2/EJ$$

$$L_{AG}^{xo} = \int_0^b (-1/4 x^2/b^2) Fb 1/EJ dx = [-1/12 x^3/b^2]_0^b Fb 1/EJ$$

$$= (-1/12 b) Fb 1/EJ = -1/12 Fb^2/EJ$$

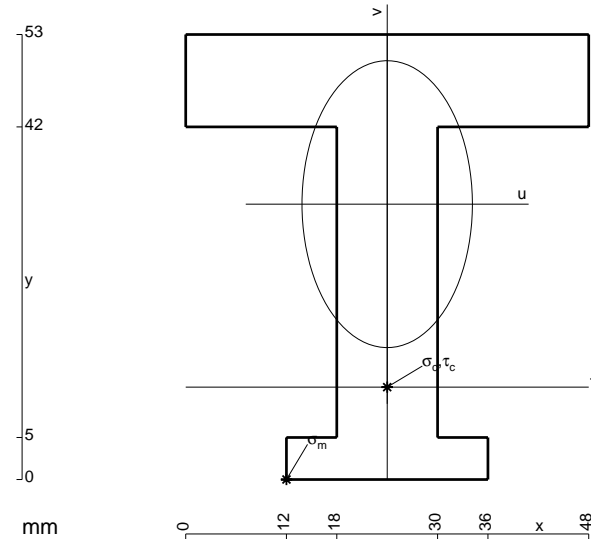

- A = 1092. mm²
- J_u = 318895. mm⁴
- J_v = 112464. mm⁴
- y_g = 32.8 mm
- T_y = -3325. N
- M_x = -2327500. Nmm
- x_m = 12. mm
- u_m = -12. mm
- v_m = -32.8 mm
- σ_m = -Mv/J_u = -239.4 N/mm²
- x_c = 24. mm
- y_c = 11. mm
- v_c = -21.8 mm
- σ_c = -Mv/J_u = -159.1 N/mm²
- τ_c = 4.71 N/mm²
- σ_o = √σ_c² + 3τ_c² = 159.3 N/mm²
- S = 5421. mm³

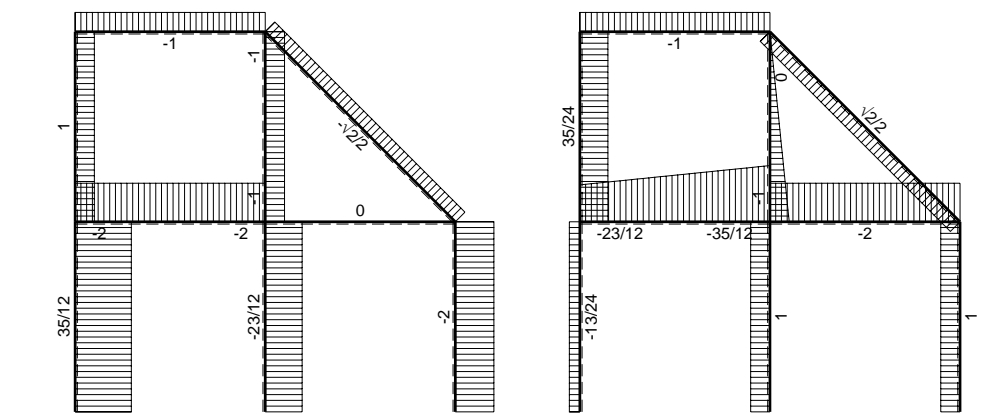
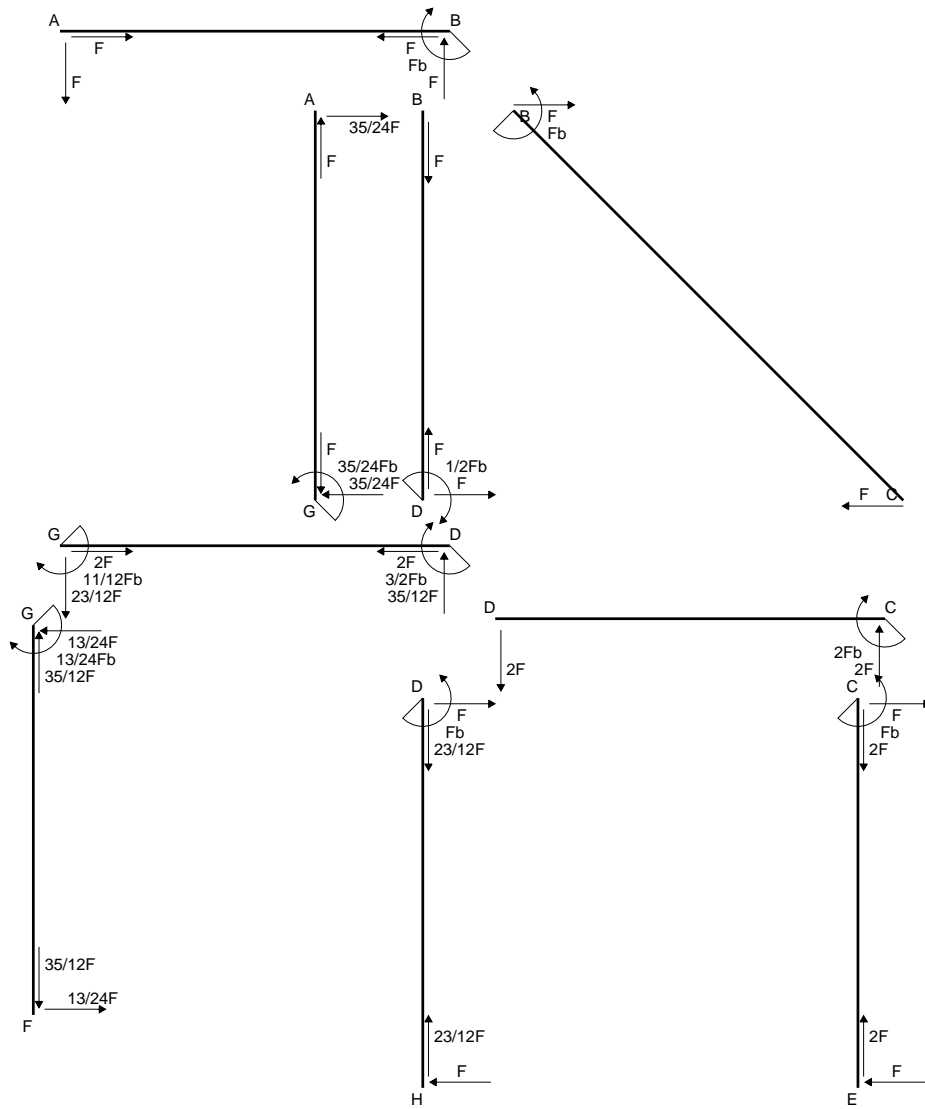

← ⊕ → F

↑ ⊕ ↓ F

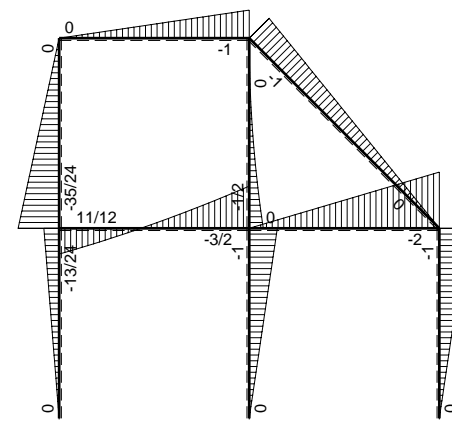

⊕ F_b

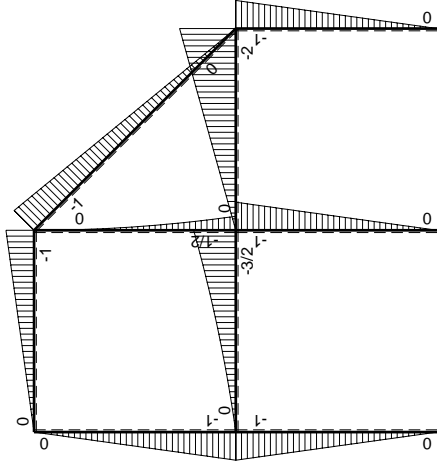
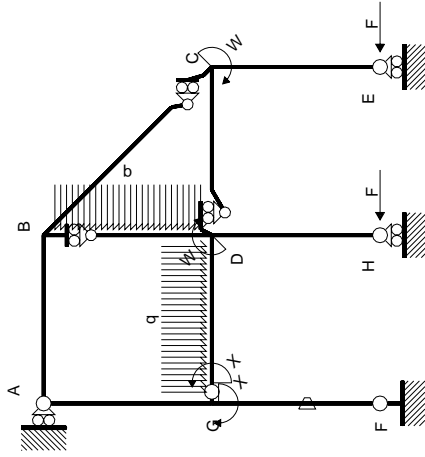

Schema di calcolo iperstatico

M_0 flessione da carichi assegnati

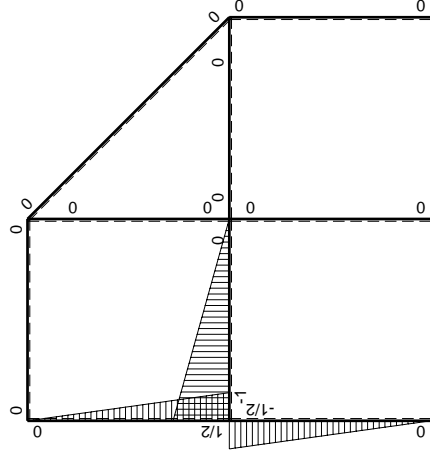

M_x flessione da iperstatica $X=1$

Quadro contributi PLV per iperstatica $X=W_{GD}$

→	$M_x(x)$	$M_o(x)$	θ	$M_x M_o$	$M_x \theta$	$M_x M_x$	$\int M_x(M_o/EJ+\theta)dx$	$\int X M_x M_x/EJdx$
AB b	0	-Fx	0	0	0	0	0+0	0
BA b	0	Fb-Fx	0	0	0	0	0	0
BC $\sqrt{2}b$	0	-Fb+ $\sqrt{2}/2Fx$	0	0	0	0	0	0
BD b	0	-1/2qx ²	0	0	0	0	0+0	0
DB b	0	1/2Fb-Fx+1/2qx ²	0	0	0	0	0	0
DC b	0	-2Fx	0	0	0	0	0+0	0
CD b	0	2Fb-2Fx	0	0	0	0	0	0
CE b	0	-Fb+Fx	0	0	0	0	0+0	0
EC b	0	Fx	0	0	0	0	0	0
FG b	-1/2x/b	-Fx	-Fb/EJ	1/2Fx ² /b	1/2Fx/EJ	1/4x ² /b ²	(1/6+1/4)Fb ² /EJ	1/12Xb/EJ
GF b	1/2-1/2x/b	Fb-Fx	Fb/EJ	1/2Fb-Fx+1/2Fx ² /b	1/2Fb/EJ-1/2Fx/EJ	1/4-1/2x/b+1/4x ² /b ²		
GD b	-1+x/b	-Fx-1/2qx ²	0	Fx-1/2Fx ² /b-1/2qx ³ /b	0	1-2x/b+x ² /b ²	(5/24+0)Fb ² /EJ	1/3Xb/EJ
DG b	x/b	3/2Fb-2Fx+1/2qx ²	0	3/2Fx-2Fx ² /b+1/2qx ³ /b	0	x ² /b ²		
DH b	0	-Fb+Fx	0	0	0	0	0+0	0
HD b	0	Fx	0	0	0	0	0	0
GA b	1/2-1/2x/b	-Fb+Fx	0	-1/2Fb+Fx-1/2Fx ² /b	0	1/4-1/2x/b+1/4x ² /b ²	(-1/6+0)Fb ² /EJ	1/12Xb/EJ
AG b	-1/2x/b	Fx	0	-1/2Fx ² /b	0	1/4x ² /b ²		
	totali						11/24Fb ² /EJ	1/2Xb/EJ
	iperstatica $X=W_{GD}$						-11/12Fb	

Sviluppi di calcolo iperstatica

$$L_{FG}^{xx} = \int_0^b (1/4 x^2/b^2) 1/EJ dx = [1/12 x^3/b^2]_0^b 1/EJ$$

$$= (1/12 b) 1/EJ = 1/12 b/EJ$$

$$L_{GF}^{xx} = \int_0^b (1/4 - 1/2 x/b + 1/4 x^2/b^2) 1/EJ dx = [1/4 x - 1/4 x^2/b + 1/12 x^3/b^2]_0^b 1/EJ$$

$$= (1/4 b - 1/4 b + 1/12 b) 1/EJ = 1/12 b/EJ$$

$$L_{GD}^{xx} = \int_0^b (1 - 2 x/b + x^2/b^2) 1/EJ dx = [x - x^2/b + 1/3 x^3/b^2]_0^b 1/EJ$$

$$= (b - b + 1/3 b) 1/EJ = 1/3 b/EJ$$

$$L_{DG}^{xx} = \int_0^b (x^2/b^2) 1/EJ dx = [1/3 x^3/b^2]_0^b 1/EJ$$

$$= (1/3 b) 1/EJ = 1/3 b/EJ$$

$$L_{GA}^{xx} = \int_0^b (1/4 - 1/2 x/b + 1/4 x^2/b^2) 1/EJ dx = [1/4 x - 1/4 x^2/b + 1/12 x^3/b^2]_0^b 1/EJ$$

$$= (1/4 b - 1/4 b + 1/12 b) 1/EJ = 1/12 b/EJ$$

$$L_{AG}^{xx} = \int_0^b (1/4 x^2/b^2) 1/EJ dx = [1/12 x^3/b^2]_0^b 1/EJ$$

$$= (1/12 b) 1/EJ = 1/12 b/EJ$$

$$L_{FG}^{xo} = \int_0^b (1/2 x^2/b^2) Fb 1/EJ dx + \int_0^b (1/2 x/b) \theta dx = [1/6 x^3/b^2]_0^b Fb 1/EJ + [1/4 x^2/b]_0^b \theta$$

$$= (1/6 b) Fb 1/EJ + (1/4 b) \theta = 5/12 Fb^2/EJ$$

$$L_{GF}^{xo} = \int_0^b (1/2 - x/b + 1/2 x^2/b^2) Fb 1/EJ dx + \int_0^b (-1/2 + 1/2 x/b) \theta dx$$

$$= [1/2 x - 1/2 x^2/b + 1/6 x^3/b^2]_0^b Fb 1/EJ + [-1/2 x + 1/4 x^2/b]_0^b \theta$$

$$= (1/2 b - 1/2 b + 1/6 b) Fb 1/EJ + (-1/2 b + 1/4 b) \theta = 5/12 Fb^2/EJ$$

$$L_{GD}^{xo} = \int_0^b (x/b - 1/2 x^2/b^2 - 1/2 x^3/b^3) Fb 1/EJ dx = [1/2 x^2/b - 1/6 x^3/b^2 - 1/8 x^4/b^3]_0^b Fb 1/EJ$$

$$= (1/2 b - 1/6 b - 1/8 b) Fb 1/EJ = 5/24 Fb^2/EJ$$

$$L_{DG}^{xo} = \int_0^b (3/2 x/b - 2 x^2/b^2 + 1/2 x^3/b^3) Fb 1/EJ dx = [3/4 x^2/b - 2/3 x^3/b^2 + 1/8 x^4/b^3]_0^b Fb 1/EJ$$

$$= (3/4 b - 2/3 b + 1/8 b) Fb 1/EJ = 5/24 Fb^2/EJ$$

$$L_{GA}^{xo} = \int_0^b (-1/2 + x/b - 1/2 x^2/b^2) Fb 1/EJ dx = [-1/2 x + 1/2 x^2/b - 1/6 x^3/b^2]_0^b Fb 1/EJ$$

$$= (-1/2 b + 1/2 b - 1/6 b) Fb 1/EJ = -1/6 Fb^2/EJ$$

$$L_{AG}^{xo} = \int_0^b (-1/2 x^2/b^2) Fb 1/EJ dx = [-1/6 x^3/b^2]_0^b Fb 1/EJ$$

$$= (-1/6 b) Fb 1/EJ = -1/6 Fb^2/EJ$$

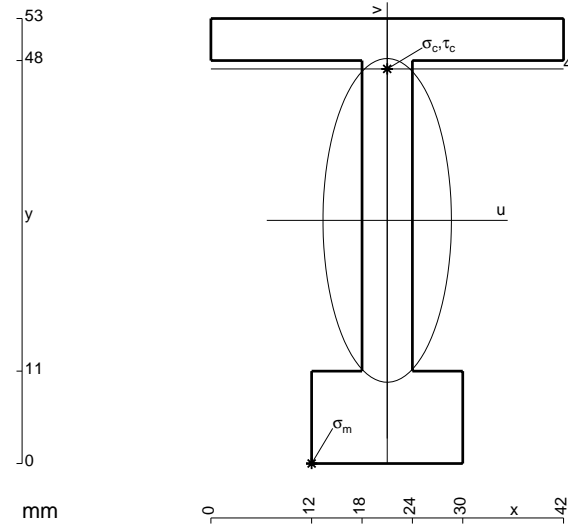

- A = 630. mm²
- J_u = 234233. mm⁴
- J_v = 36882. mm⁴
- y_g = 28.96 mm
- T_y = -2140. N
- M_x = -1605000. Nmm
- x_m = 12. mm
- u_m = -9. mm
- v_m = -28.96 mm
- σ_m = -M_v/J_u = -198.4 N/mm²
- x_c = 21. mm
- y_c = 47. mm
- v_c = 18.04 mm
- σ_c = -M_v/J_u = 123.6 N/mm²
- τ_c = 7.058 N/mm²
- σ_o = √σ²+3τ² = 124.2 N/mm²
- S = 4635. mm³

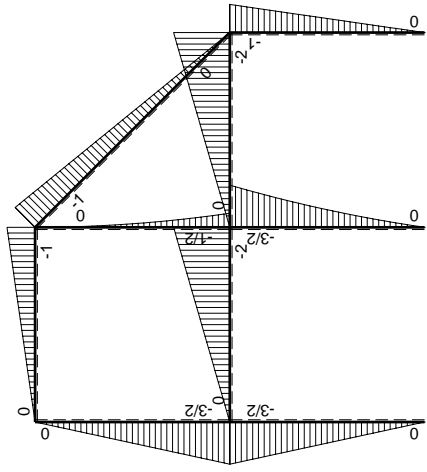
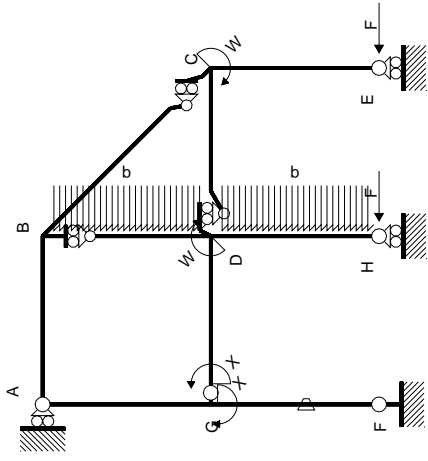

Schema di calcolo iperstatico

M_0 flessione da carichi assegnati

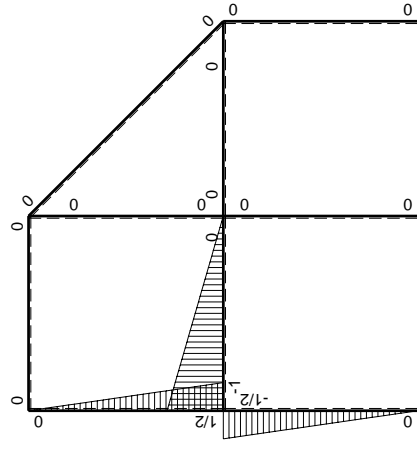

M_x flessione da iperstatica $X=1$

Quadro contributi PLV per iperstatica $X=W_{GD}$

→	$M_x(x)$	$M_o(x)$	θ	$M_x M_o$	$M_x \theta$	$M_x M_x$	$\int M_x(M_o/EJ+\theta)dx$	$\int X M_x M_x/EJdx$	
AB b	0	-Fx	0	0	0	0	0+0	0	
BA b	0	Fb-Fx	0	0	0	0			
BC $\sqrt{2}b$	0	-Fb+ $\sqrt{2}/2Fx$	0	0	0	0	0	0	
BD b	0	-1/2qx ²	0	0	0	0	0+0	0	
DB b	0	1/2Fb-Fx+1/2qx ²	0	0	0	0			
DC b	0	-2Fx	0	0	0	0	0+0	0	
CD b	0	2Fb-2Fx	0	0	0	0			
CE b	0	-Fb+Fx	0	0	0	0	0+0	0	
EC b	0	Fx	0	0	0	0			
FG b	-1/2x/b	-3/2Fx	-Fb/EJ	3/4Fx ² /b	1/2Fx/EJ	1/4x ² /b ²	(1/4+1/4)Fb ² /EJ	1/12Xb/EJ	
GF b	1/2-1/2x/b	3/2Fb-3/2Fx	Fb/EJ	3/4Fb-3/2Fx+3/4Fx ² /b	1/2Fb/EJ-1/2Fx/EJ	1/4-1/2x/b+1/4x ² /b ²			
GD b	-1+x/b	-2Fx	0	2Fx-2Fx ² /b	0	1-2x/b+x ² /b ²	(1/3+0)Fb ² /EJ	1/3Xb/EJ	
DG b	x/b	2Fb-2Fx	0	2Fx-2Fx ² /b	0	x ² /b ²			
DH b	0	-3/2Fb+2Fx-1/2qx ²	0	0	0	0	0+0	0	
HD b	0	Fx+1/2qx ²	0	0	0	0			
GA b	1/2-1/2x/b	-3/2Fb+3/2Fx	0	-3/4Fb+3/2Fx-3/4Fx ² /b	0	1/4-1/2x/b+1/4x ² /b ²	(-1/4+0)Fb ² /EJ	1/12Xb/EJ	
AG b	-1/2x/b	3/2Fx	0	-3/4Fx ² /b	0	1/4x ² /b ²			
	totali							7/12Fb ² /EJ	1/2Xb/EJ
	iperstatica $X=W_{GD}$							-7/6Fb	

Sviluppi di calcolo iperstatica

$$L_{FG}^{xx} = \int_0^b (1/4 x^2/b^2) 1/EJ dx = [1/12 x^3/b^2]_0^b 1/EJ$$

$$= (1/12 b) 1/EJ = 1/12 b/EJ$$

$$L_{GF}^{xx} = \int_0^b (1/4 - 1/2 x/b + 1/4 x^2/b^2) 1/EJ dx = [1/4 x - 1/4 x^2/b + 1/12 x^3/b^2]_0^b 1/EJ$$

$$= (1/4 b - 1/4 b + 1/12 b) 1/EJ = 1/12 b/EJ$$

$$L_{GD}^{xx} = \int_0^b (1 - 2 x/b + x^2/b^2) 1/EJ dx = [x - x^2/b + 1/3 x^3/b^2]_0^b 1/EJ$$

$$= (b - b + 1/3 b) 1/EJ = 1/3 b/EJ$$

$$L_{DG}^{xx} = \int_0^b (x^2/b^2) 1/EJ dx = [1/3 x^3/b^2]_0^b 1/EJ$$

$$= (1/3 b) 1/EJ = 1/3 b/EJ$$

$$L_{GA}^{xx} = \int_0^b (1/4 - 1/2 x/b + 1/4 x^2/b^2) 1/EJ dx = [1/4 x - 1/4 x^2/b + 1/12 x^3/b^2]_0^b 1/EJ$$

$$= (1/4 b - 1/4 b + 1/12 b) 1/EJ = 1/12 b/EJ$$

$$L_{AG}^{xx} = \int_0^b (1/4 x^2/b^2) 1/EJ dx = [1/12 x^3/b^2]_0^b 1/EJ$$

$$= (1/12 b) 1/EJ = 1/12 b/EJ$$

$$L_{FG}^{xo} = \int_0^b (3/4 x^2/b^2) Fb 1/EJ dx + \int_0^b (1/2 x/b) \theta dx = [1/4 x^3/b^2]_0^b Fb 1/EJ + [1/4 x^2/b]_0^b \theta$$

$$= (1/4 b) Fb 1/EJ + (1/4 b) \theta = 1/2 Fb^2/EJ$$

$$L_{GF}^{xo} = \int_0^b (3/4 - 3/2 x/b + 3/4 x^2/b^2) Fb 1/EJ dx + \int_0^b (-1/2 + 1/2 x/b) \theta dx$$

$$= [3/4 x - 3/4 x^2/b + 1/4 x^3/b^2]_0^b Fb 1/EJ + [-1/2 x + 1/4 x^2/b]_0^b \theta$$

$$= (3/4 b - 3/4 b + 1/4 b) Fb 1/EJ + (-1/2 b + 1/4 b) \theta = 1/2 Fb^2/EJ$$

$$L_{GD}^{xo} = \int_0^b (2 x/b - 2 x^2/b^2) Fb 1/EJ dx = [x^2/b - 2/3 x^3/b^2]_0^b Fb 1/EJ$$

$$= (b - 2/3 b) Fb 1/EJ = 1/3 Fb^2/EJ$$

$$L_{DG}^{xo} = \int_0^b (2 x/b - 2 x^2/b^2) Fb 1/EJ dx = [x^2/b - 2/3 x^3/b^2]_0^b Fb 1/EJ$$

$$= (b - 2/3 b) Fb 1/EJ = 1/3 Fb^2/EJ$$

$$L_{GA}^{xo} = \int_0^b (-3/4 + 3/2 x/b - 3/4 x^2/b^2) Fb 1/EJ dx = [-3/4 x + 3/4 x^2/b - 1/4 x^3/b^2]_0^b Fb 1/EJ$$

$$= (-3/4 b + 3/4 b - 1/4 b) Fb 1/EJ = -1/4 Fb^2/EJ$$

$$L_{AG}^{xo} = \int_0^b (-3/4 x^2/b^2) Fb 1/EJ dx = [-1/4 x^3/b^2]_0^b Fb 1/EJ$$

$$= (-1/4 b) Fb 1/EJ = -1/4 Fb^2/EJ$$

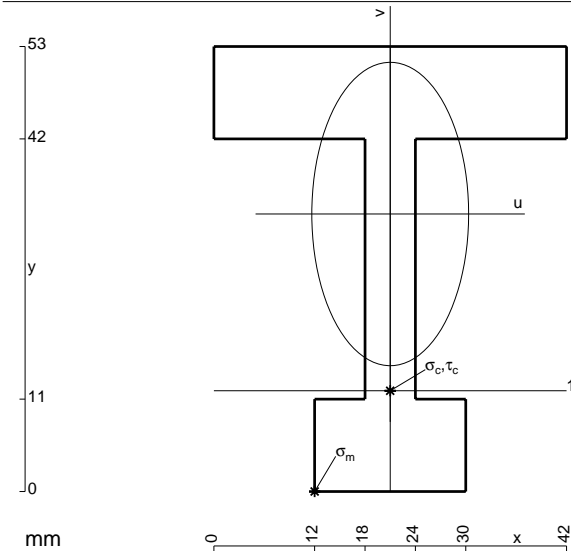

- A = 846. mm²
- J_u = 276280. mm⁴
- J_v = 73818. mm⁴
- y_g = 33.05 mm
- T_y = -2180. N
- M_x = -1744000. Nmm
- x_m = 12. mm
- u_m = -9. mm
- v_m = -33.05 mm
- σ_m = -Mv/J_u = -208.6 N/mm²
- x_c = 21. mm
- y_c = 12. mm
- v_c = -21.05 mm
- σ_c = -Mv/J_u = -132.9 N/mm²
- τ_c = 7.345 N/mm²
- σ_o = √σ² + 3τ² = 133.5 N/mm²
- S = 5585. mm³

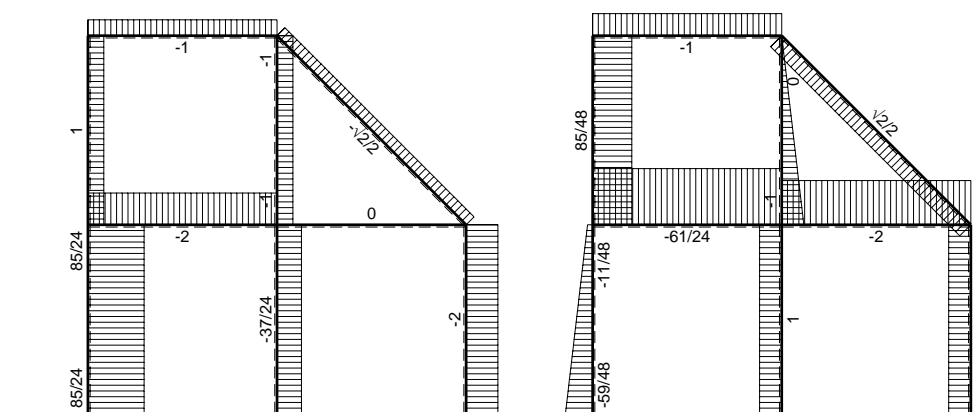
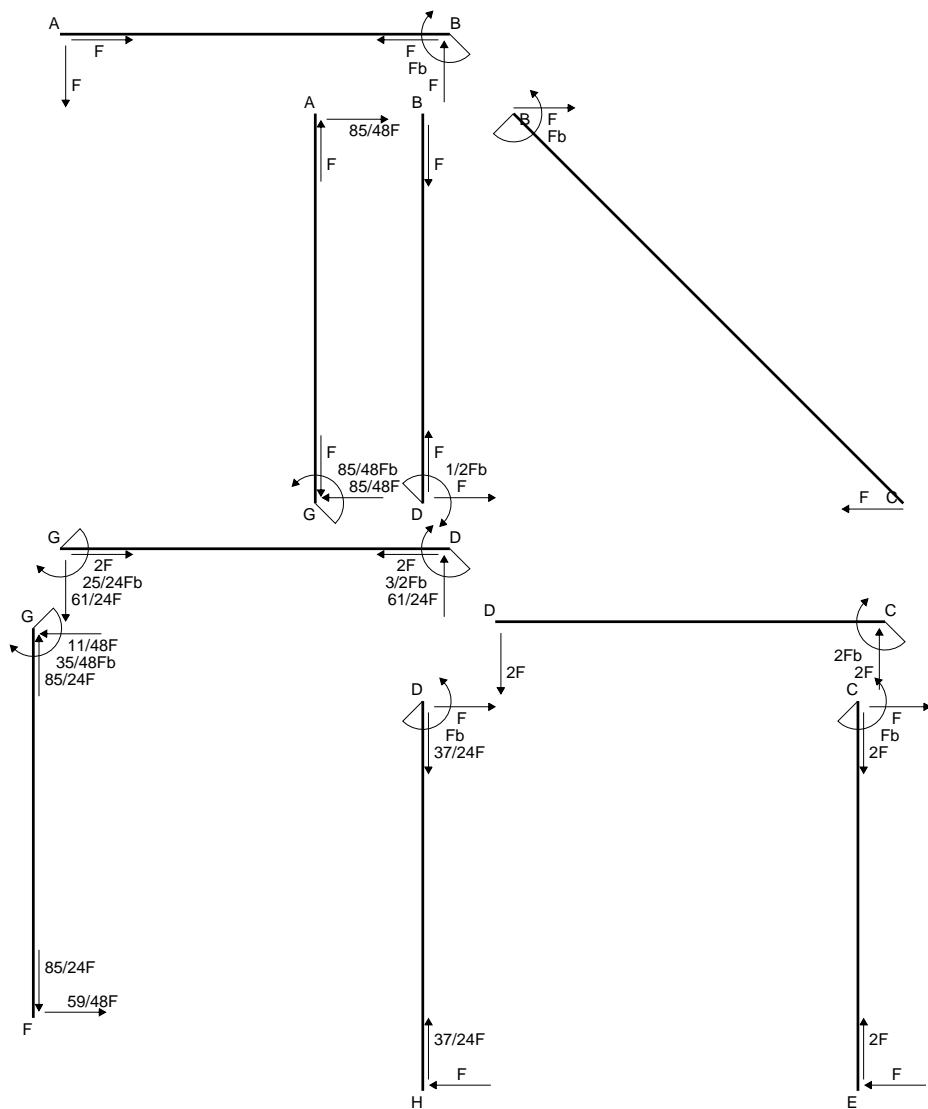

← ⊕ → F

↑ ⊕ ↓ F

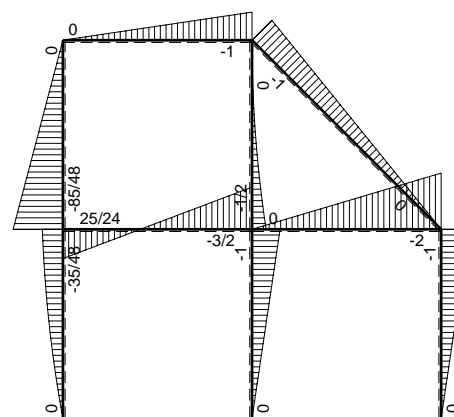

⊕ F_b

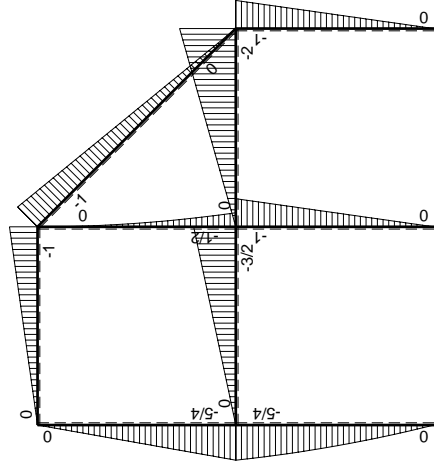
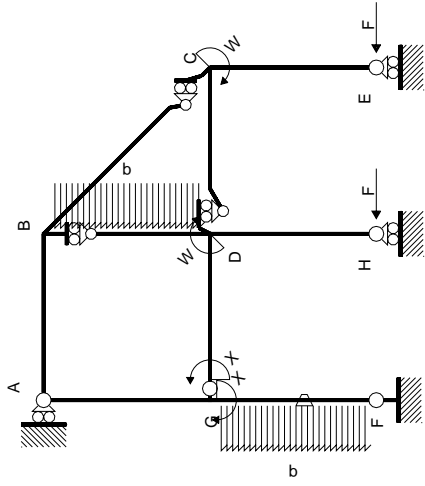

Schema di calcolo iperstatico

M_0 flessione da carichi assegnati

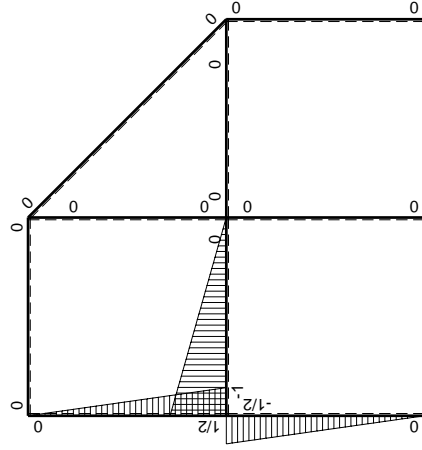

M_x flessione da iperstatica $X=1$

Quadro contributi PLV per iperstatica $X=W_{GD}$

→	$M_x(x)$	$M_o(x)$	θ	$M_x M_o$	$M_x \theta$	$M_x M_x$	$\int M_x(M_o/EJ+\theta)dx$	$\int X M_x M_x / EJ dx$
AB b	0	-Fx	0	0	0	0	0+0	0
BA b	0	Fb-Fx	0	0	0	0	0	0
BC $\sqrt{2}b$	0	-Fb+ $\sqrt{2}/2Fx$	0	0	0	0	0	0
BD b	0	-1/2qx ²	0	0	0	0	0+0	0
DB b	0	1/2Fb-Fx+1/2qx ²	0	0	0	0	0	0
DC b	0	-2Fx	0	0	0	0	0+0	0
CD b	0	2Fb-2Fx	0	0	0	0	0	0
CE b	0	-Fb+Fx	0	0	0	0	0+0	0
EC b	0	Fx	0	0	0	0	0	0
FG b	-1/2x/b	-7/4Fx+1/2qx ²	-Fb/EJ	7/8Fx ² /b-1/4qx ³ /b	1/2Fx/EJ	1/4x ² /b ²	(11/48+1/4)Fb ² /EJ	1/12Xb/EJ
GF b	1/2-1/2x/b	5/4Fb-3/4Fx-1/2qx ²	Fb/EJ	5/8Fb-Fx+1/8Fx ² /b+1/4qx ³ /b	1/2Fb/EJ-1/2Fx/EJ	1/4-1/2x/b+1/4x ² /b ²		
GD b	-1+x/b	-3/2Fx	0	3/2Fx-3/2Fx ² /b	0	1-2x/b+x ² /b ²	(1/4+0)Fb ² /EJ	1/3Xb/EJ
DG b	x/b	3/2Fb-3/2Fx	0	3/2Fx-3/2Fx ² /b	0	x ² /b ²		
DH b	0	-Fb+Fx	0	0	0	0	0+0	0
HD b	0	Fx	0	0	0	0	0	0
GA b	1/2-1/2x/b	-5/4Fb+5/4Fx	0	-5/8Fb+5/4Fx-5/8Fx ² /b	0	1/4-1/2x/b+1/4x ² /b ²	(-5/24+0)Fb ² /EJ	1/12Xb/EJ
AG b	-1/2x/b	5/4Fx	0	-5/8Fx ² /b	0	1/4x ² /b ²		
	totali						25/48Fb ² /EJ	1/2Xb/EJ
	iperstatica $X=W_{GD}$						-25/24Fb	

Sviluppi di calcolo iperstatica

$$L_{FG}^{xx} = \int_0^b (1/4 x^2/b^2) 1/EJ dx = [1/12 x^3/b^2]_0^b 1/EJ$$

$$= (1/12 b) 1/EJ = 1/12 b/EJ$$

$$L_{GF}^{xx} = \int_0^b (1/4 - 1/2 x/b + 1/4 x^2/b^2) 1/EJ dx = [1/4 x - 1/4 x^2/b + 1/12 x^3/b^2]_0^b 1/EJ$$

$$= (1/4 b - 1/4 b + 1/12 b) 1/EJ = 1/12 b/EJ$$

$$L_{GD}^{xx} = \int_0^b (1 - 2 x/b + x^2/b^2) 1/EJ dx = [x - x^2/b + 1/3 x^3/b^2]_0^b 1/EJ$$

$$= (b - b + 1/3 b) 1/EJ = 1/3 b/EJ$$

$$L_{DG}^{xx} = \int_0^b (x^2/b^2) 1/EJ dx = [1/3 x^3/b^2]_0^b 1/EJ$$

$$= (1/3 b) 1/EJ = 1/3 b/EJ$$

$$L_{GA}^{xx} = \int_0^b (1/4 - 1/2 x/b + 1/4 x^2/b^2) 1/EJ dx = [1/4 x - 1/4 x^2/b + 1/12 x^3/b^2]_0^b 1/EJ$$

$$= (1/4 b - 1/4 b + 1/12 b) 1/EJ = 1/12 b/EJ$$

$$L_{AG}^{xx} = \int_0^b (1/4 x^2/b^2) 1/EJ dx = [1/12 x^3/b^2]_0^b 1/EJ$$

$$= (1/12 b) 1/EJ = 1/12 b/EJ$$

$$L_{FG}^{xo} = \int_0^b (7/8 x^2/b^2 - 1/4 x^3/b^3) Fb 1/EJ dx + \int_0^b (1/2 x/b) \theta dx$$

$$= [7/24 x^3/b^2 - 1/16 x^4/b^3]_0^b Fb 1/EJ + [1/4 x^2/b]_0^b \theta$$

$$= (7/24 b - 1/16 b) Fb 1/EJ + (1/4 b) \theta = 23/48 Fb^2/EJ$$

$$L_{GF}^{xo} = \int_0^b (5/8 - x/b + 1/8 x^2/b^2 + 1/4 x^3/b^3) Fb 1/EJ dx + \int_0^b (-1/2 + 1/2 x/b) \theta dx$$

$$= [5/8 x - 1/2 x^2/b + 1/24 x^3/b^2 + 1/16 x^4/b^3]_0^b Fb 1/EJ + [-1/2 x + 1/4 x^2/b]_0^b \theta$$

$$= (5/8 b - 1/2 b + 1/24 b + 1/16 b) Fb 1/EJ + (-1/2 b + 1/4 b) \theta = 23/48 Fb^2/EJ$$

$$L_{GD}^{xo} = \int_0^b (3/2 x/b - 3/2 x^2/b^2) Fb 1/EJ dx = [3/4 x^2/b - 1/2 x^3/b^2]_0^b Fb 1/EJ$$

$$= (3/4 b - 1/2 b) Fb 1/EJ = 1/4 Fb^2/EJ$$

$$L_{DG}^{xo} = \int_0^b (3/2 x/b - 3/2 x^2/b^2) Fb 1/EJ dx = [3/4 x^2/b - 1/2 x^3/b^2]_0^b Fb 1/EJ$$

$$= (3/4 b - 1/2 b) Fb 1/EJ = 1/4 Fb^2/EJ$$

$$L_{GA}^{xo} = \int_0^b (-5/8 + 5/4 x/b - 5/8 x^2/b^2) Fb 1/EJ dx = [-5/8 x + 5/8 x^2/b - 5/24 x^3/b^2]_0^b Fb 1/EJ$$

$$= (-5/8 b + 5/8 b - 5/24 b) Fb 1/EJ = -5/24 Fb^2/EJ$$

$$L_{AG}^{xo} = \int_0^b (-5/8 x^2/b^2) Fb 1/EJ dx = [-5/24 x^3/b^2]_0^b Fb 1/EJ$$

$$= (-5/24 b) Fb 1/EJ = -5/24 Fb^2/EJ$$

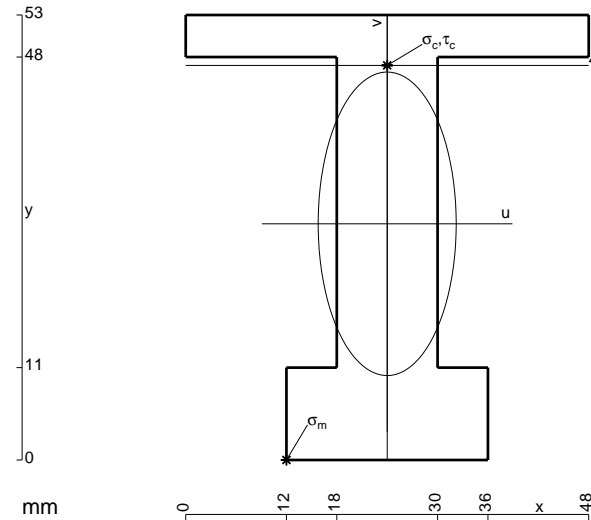

- A = 948. mm²
- J_u = 309947. mm⁴
- J_v = 64080. mm⁴
- y_g = 28.13 mm
- T_y = -2840. N
- M_x = -2414000. Nmm
- x_m = 12. mm
- u_m = -12. mm
- v_m = -28.13 mm
- σ_m = -Mv/J_u = -219.1 N/mm²
- x_c = 24. mm
- y_c = 47. mm
- v_c = 18.87 mm
- σ_c = -Mv/J_u = 146.9 N/mm²
- τ_c = 4.276 N/mm²
- σ_q = √σ²+3τ² = 147.1 N/mm²
- S = 5601. mm³

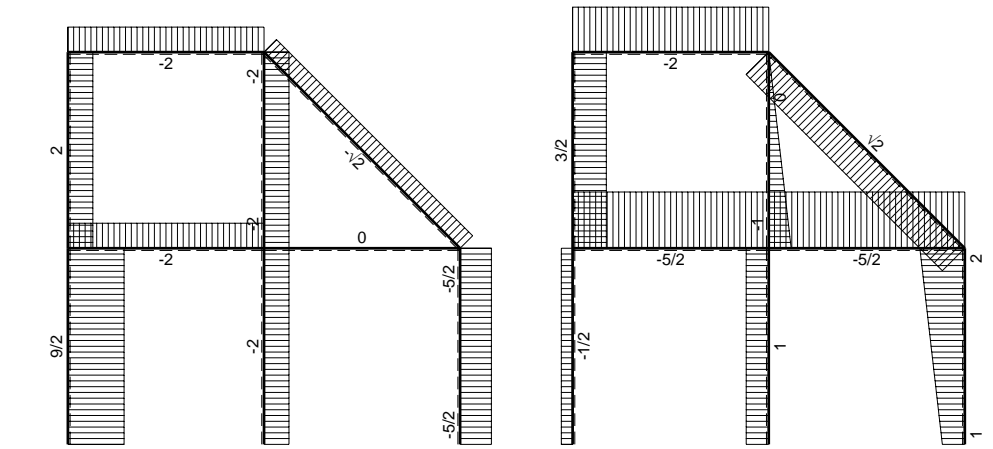
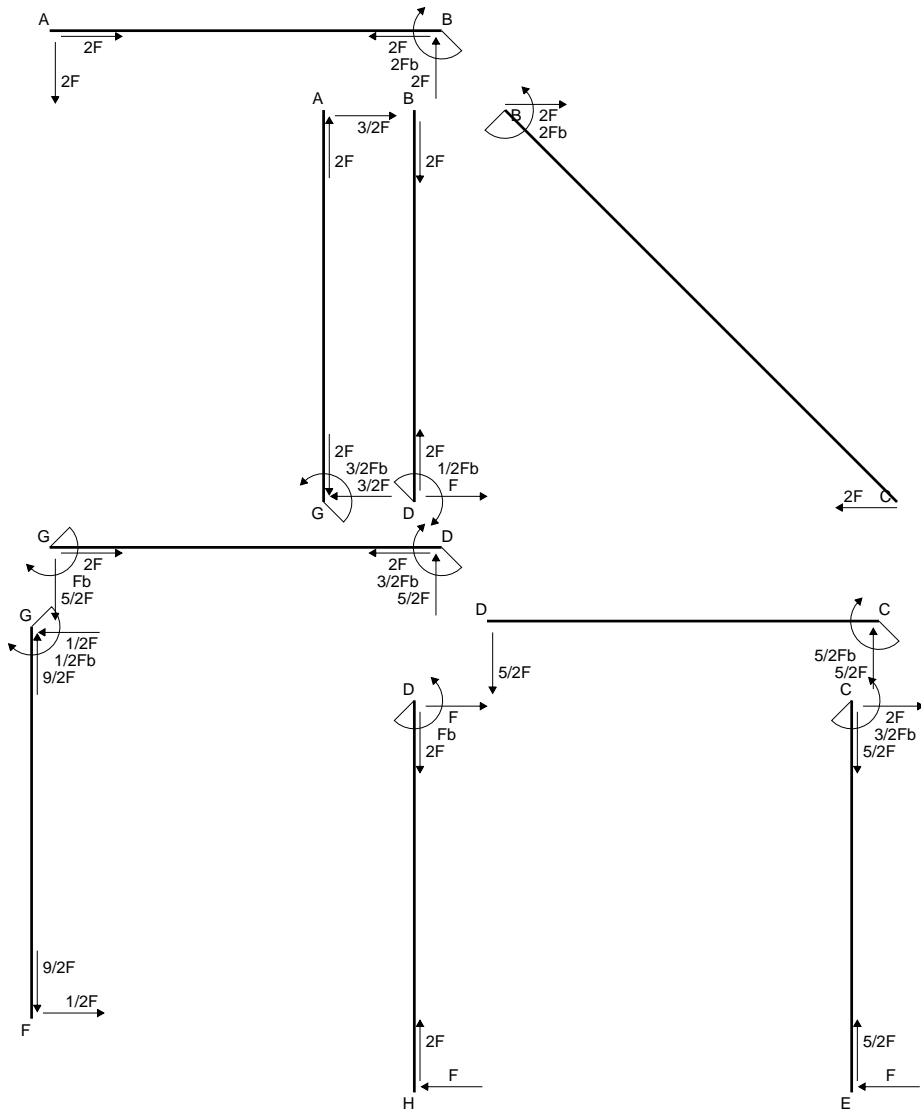

← ⊕ → F

↑ ⊕ ↓ F

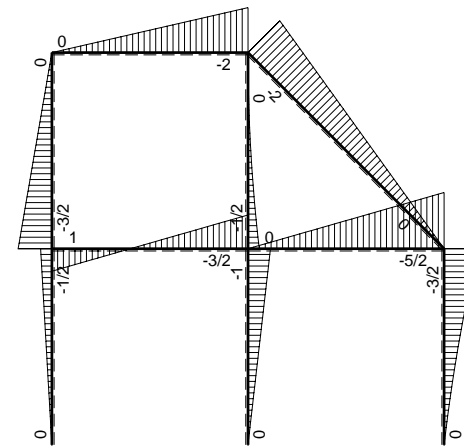

⊕ Fb

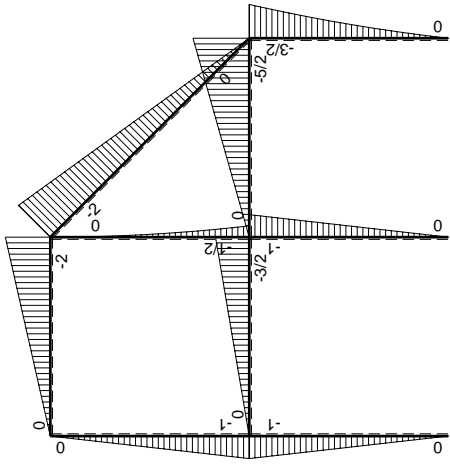
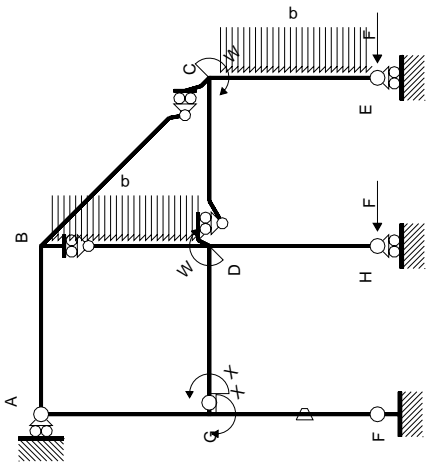

Schema di calcolo iperstatico

M_0 flessione da carichi assegnati

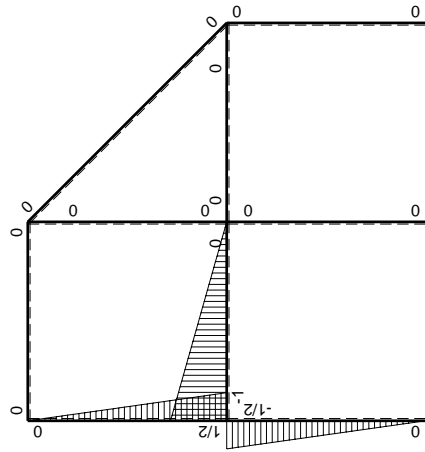

M_x flessione da iperstatica $X=1$

Quadro contributi PLV per iperstatica $X=W_{GD}$

→	$M_x(x)$	$M_o(x)$	θ	$M_x M_o$	$M_x \theta$	$M_x M_x$	$\int M_x(M_o/EJ+\theta)dx$	$\int X M_x M_x/EJ dx$
AB b	0	-2Fx	0	0	0	0	0+0	0
BA b	0	2Fb-2Fx	0	0	0	0	0	0
BC $\sqrt{2}b$	0	-2Fb+ $\sqrt{2}Fx$	0	0	0	0	0	0
BD b	0	-1/2qx ²	0	0	0	0	0+0	0
DB b	0	1/2Fb-Fx+1/2qx ²	0	0	0	0	0	0
DC b	0	-5/2Fx	0	0	0	0	0+0	0
CD b	0	5/2Fb-5/2Fx	0	0	0	0	0	0
CE b	0	-3/2Fb+2Fx-1/2qx ²	0	0	0	0	0+0	0
EC b	0	Fx+1/2qx ²	0	0	0	0	0	0
FG b	-1/2x/b	-Fx	-Fb/EJ	1/2Fx ² /b	1/2Fx/EJ	1/4x ² /b ²	(1/6+1/4)Fb ² /EJ	1/12Xb/EJ
GF b	1/2-1/2x/b	Fb-Fx	Fb/EJ	1/2Fb-Fx+1/2Fx ² /b	1/2Fb/EJ-1/2Fx/EJ	1/4-1/2x/b+1/4x ² /b ²		
GD b	-1+x/b	-3/2Fx	0	3/2Fx-3/2Fx ² /b	0	1-2x/b+x ² /b ²	(1/4+0)Fb ² /EJ	1/3Xb/EJ
DG b	x/b	3/2Fb-3/2Fx	0	3/2Fx-3/2Fx ² /b	0	x ² /b ²		
DH b	0	-Fb+Fx	0	0	0	0	0+0	0
HD b	0	Fx	0	0	0	0	0	0
GA b	1/2-1/2x/b	-Fb+Fx	0	-1/2Fb+Fx-1/2Fx ² /b	0	1/4-1/2x/b+1/4x ² /b ²	(-1/6+0)Fb ² /EJ	1/12Xb/EJ
AG b	-1/2x/b	Fx	0	-1/2Fx ² /b	0	1/4x ² /b ²		
	totali						1/2Fb ² /EJ	1/2Xb/EJ
	iperstatica $X=W_{GD}$						-Fb	

Sviluppi di calcolo iperstatica

$$L_{FG}^{xx} = \int_0^b (1/4 x^2/b^2) 1/EJ dx = [1/12 x^3/b^2]_0^b 1/EJ$$

$$= (1/12 b) 1/EJ = 1/12 b/EJ$$

$$L_{GF}^{xx} = \int_0^b (1/4 - 1/2 x/b + 1/4 x^2/b^2) 1/EJ dx = [1/4 x - 1/4 x^2/b + 1/12 x^3/b^2]_0^b 1/EJ$$

$$= (1/4 b - 1/4 b + 1/12 b) 1/EJ = 1/12 b/EJ$$

$$L_{GD}^{xx} = \int_0^b (1 - 2 x/b + x^2/b^2) 1/EJ dx = [x - x^2/b + 1/3 x^3/b^2]_0^b 1/EJ$$

$$= (b - b + 1/3 b) 1/EJ = 1/3 b/EJ$$

$$L_{DG}^{xx} = \int_0^b (x^2/b^2) 1/EJ dx = [1/3 x^3/b^2]_0^b 1/EJ$$

$$= (1/3 b) 1/EJ = 1/3 b/EJ$$

$$L_{GA}^{xx} = \int_0^b (1/4 - 1/2 x/b + 1/4 x^2/b^2) 1/EJ dx = [1/4 x - 1/4 x^2/b + 1/12 x^3/b^2]_0^b 1/EJ$$

$$= (1/4 b - 1/4 b + 1/12 b) 1/EJ = 1/12 b/EJ$$

$$L_{AG}^{xx} = \int_0^b (1/4 x^2/b^2) 1/EJ dx = [1/12 x^3/b^2]_0^b 1/EJ$$

$$= (1/12 b) 1/EJ = 1/12 b/EJ$$

$$L_{FG}^{xo} = \int_0^b (1/2 x^2/b^2) Fb 1/EJ dx + \int_0^b (1/2 x/b) \theta dx = [1/6 x^3/b^2]_0^b Fb 1/EJ + [1/4 x^2/b]_0^b \theta$$

$$= (1/6 b) Fb 1/EJ + (1/4 b) \theta = 5/12 Fb^2/EJ$$

$$L_{GF}^{xo} = \int_0^b (1/2 - x/b + 1/2 x^2/b^2) Fb 1/EJ dx + \int_0^b (-1/2 + 1/2 x/b) \theta dx$$

$$= [1/2 x - 1/2 x^2/b + 1/6 x^3/b^2]_0^b Fb 1/EJ + [-1/2 x + 1/4 x^2/b]_0^b \theta$$

$$= (1/2 b - 1/2 b + 1/6 b) Fb 1/EJ + (-1/2 b + 1/4 b) \theta = 5/12 Fb^2/EJ$$

$$L_{GD}^{xo} = \int_0^b (3/2 x/b - 3/2 x^2/b^2) Fb 1/EJ dx = [3/4 x^2/b - 1/2 x^3/b^2]_0^b Fb 1/EJ$$

$$= (3/4 b - 1/2 b) Fb 1/EJ = 1/4 Fb^2/EJ$$

$$L_{DG}^{xo} = \int_0^b (3/2 x/b - 3/2 x^2/b^2) Fb 1/EJ dx = [3/4 x^2/b - 1/2 x^3/b^2]_0^b Fb 1/EJ$$

$$= (3/4 b - 1/2 b) Fb 1/EJ = 1/4 Fb^2/EJ$$

$$L_{GA}^{xo} = \int_0^b (-1/2 + x/b - 1/2 x^2/b^2) Fb 1/EJ dx = [-1/2 x + 1/2 x^2/b - 1/6 x^3/b^2]_0^b Fb 1/EJ$$

$$= (-1/2 b + 1/2 b - 1/6 b) Fb 1/EJ = -1/6 Fb^2/EJ$$

$$L_{AG}^{xo} = \int_0^b (-1/2 x^2/b^2) Fb 1/EJ dx = [-1/6 x^3/b^2]_0^b Fb 1/EJ$$

$$= (-1/6 b) Fb 1/EJ = -1/6 Fb^2/EJ$$

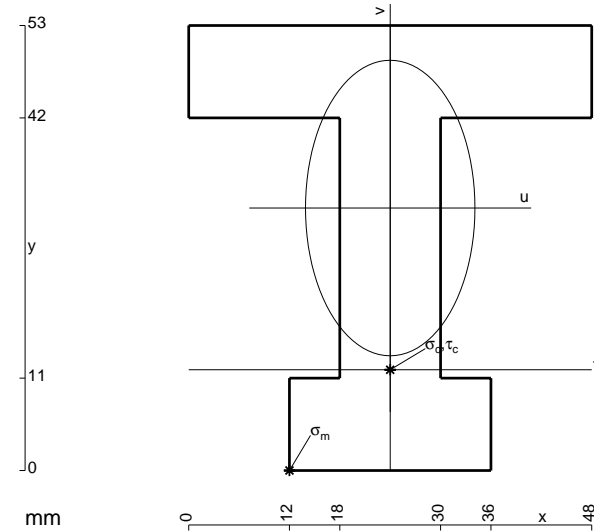

- A = 1164. mm²
- J_u = 360644. mm⁴
- J_v = 118512. mm⁴
- y_g = 31.26 mm
- T_y = -2925. N
- M_x = -2632500. Nmm
- x_m = 12. mm
- u_m = -12. mm
- v_m = -31.26 mm
- σ_m = -Mv/J_u = -228.2 N/mm²
- x_c = 24. mm
- y_c = 12. mm
- v_c = -19.26 mm
- σ_c = -Mv/J_u = -140.6 N/mm²
- τ_c = 4.757 N/mm²
- σ_o = √σ²+3τ² = 140.9 N/mm²
- S = 7039. mm³

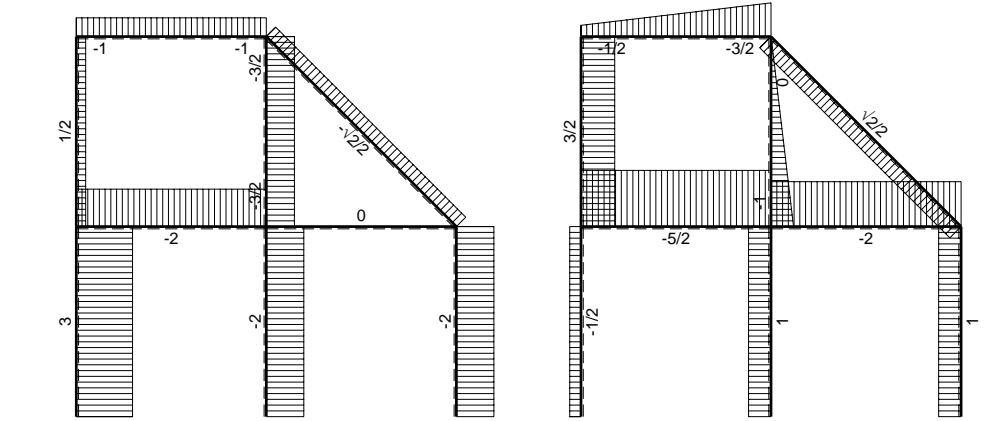
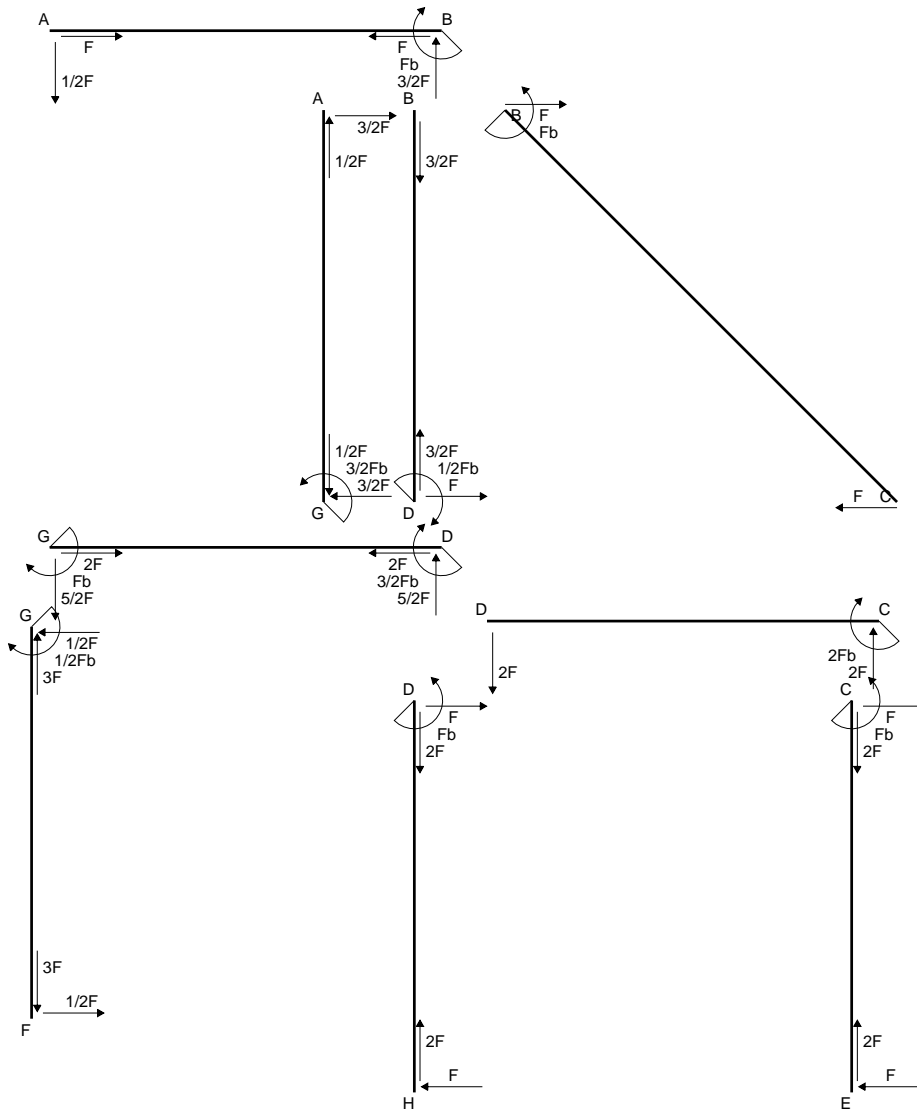

← ⊕ → F

↑ ⊕ ↓ F

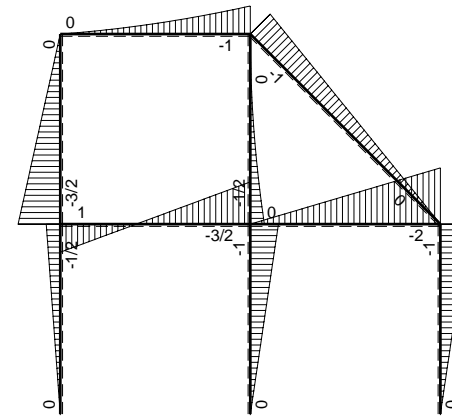

⊕ ⊖ F_b

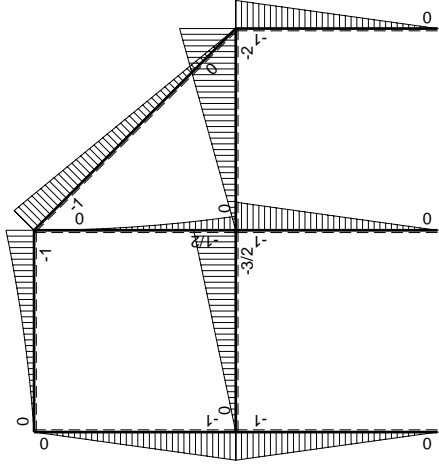
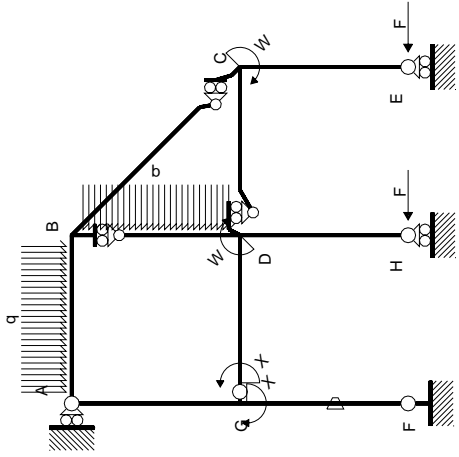

Schema di calcolo iperstatico

M_0 flessione da carichi assegnati

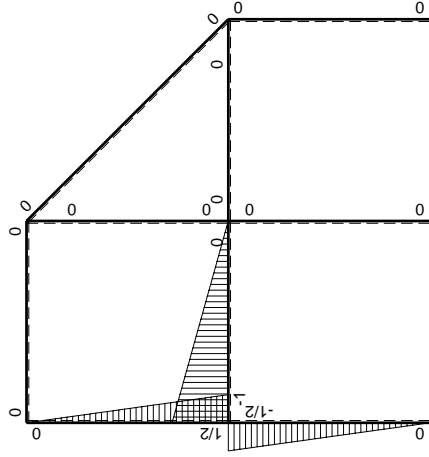

M_x flessione da iperstatica $X=1$

Quadro contributi PLV per iperstatica $X=W_{GD}$

→	$M_x(x)$	$M_o(x)$	θ	$M_x M_o$	$M_x \theta$	$M_x M_x$	$\int M_x(M_o/EJ+\theta)dx$	$\int X M_x M_x/EJdx$	
AB b	0	$-1/2Fx-1/2qx^2$	0	0	0	0	0+0	0	
BA b	0	$Fb-3/2Fx+1/2qx^2$	0	0	0	0	0	0	
BC $\sqrt{2}b$	0	$-Fb+\sqrt{2}/2Fx$	0	0	0	0	0	0	
BD b	0	$-1/2qx^2$	0	0	0	0	0+0	0	
DB b	0	$1/2Fb-Fx+1/2qx^2$	0	0	0	0	0	0	
DC b	0	$-2Fx$	0	0	0	0	0+0	0	
CD b	0	$2Fb-2Fx$	0	0	0	0	0	0	
CE b	0	$-Fb+Fx$	0	0	0	0	0+0	0	
EC b	0	Fx	0	0	0	0	0	0	
FG b	$-1/2x/b$	$-Fx$	$-Fb/EJ$	$1/2Fx^2/b$	$1/2Fx/EJ$	$1/4x^2/b^2$	$(1/6+1/4)Fb^2/EJ$	$1/12Xb/EJ$	
GF b	$1/2-1/2x/b$	$Fb-Fx$	Fb/EJ	$1/2Fb-Fx+1/2Fx^2/b$	$1/2Fb/EJ-1/2Fx/EJ$	$1/4-1/2x/b+1/4x^2/b^2$			
GD b	$-1+x/b$	$-3/2Fx$	0	$3/2Fx-3/2Fx^2/b$	0	$1-2x/b+x^2/b^2$	$(1/4+0)Fb^2/EJ$	$1/3Xb/EJ$	
DG b	x/b	$3/2Fb-3/2Fx$	0	$3/2Fx-3/2Fx^2/b$	0	x^2/b^2			
DH b	0	$-Fb+Fx$	0	0	0	0	0+0	0	
HD b	0	Fx	0	0	0	0	0	0	
GA b	$1/2-1/2x/b$	$-Fb+Fx$	0	$-1/2Fb+Fx-1/2Fx^2/b$	0	$1/4-1/2x/b+1/4x^2/b^2$	$(-1/6+0)Fb^2/EJ$	$1/12Xb/EJ$	
AG b	$-1/2x/b$	Fx	0	$-1/2Fx^2/b$	0	$1/4x^2/b^2$			
	totali							$1/2Fb^2/EJ$	$1/2Xb/EJ$
	iperstatica $X=W_{GD}$							$-Fb$	

Sviluppi di calcolo iperstatica

$$L_{FG}^{xx} = \int_0^b (1/4 x^2/b^2) 1/EJ dx = [1/12 x^3/b^2]_0^b 1/EJ$$

$$= (1/12 b) 1/EJ = 1/12 b/EJ$$

$$L_{GF}^{xx} = \int_0^b (1/4 - 1/2 x/b + 1/4 x^2/b^2) 1/EJ dx = [1/4 x - 1/4 x^2/b + 1/12 x^3/b^2]_0^b 1/EJ$$

$$= (1/4 b - 1/4 b + 1/12 b) 1/EJ = 1/12 b/EJ$$

$$L_{GD}^{xx} = \int_0^b (1 - 2 x/b + x^2/b^2) 1/EJ dx = [x - x^2/b + 1/3 x^3/b^2]_0^b 1/EJ$$

$$= (b - b + 1/3 b) 1/EJ = 1/3 b/EJ$$

$$L_{DG}^{xx} = \int_0^b (x^2/b^2) 1/EJ dx = [1/3 x^3/b^2]_0^b 1/EJ$$

$$= (1/3 b) 1/EJ = 1/3 b/EJ$$

$$L_{GA}^{xx} = \int_0^b (1/4 - 1/2 x/b + 1/4 x^2/b^2) 1/EJ dx = [1/4 x - 1/4 x^2/b + 1/12 x^3/b^2]_0^b 1/EJ$$

$$= (1/4 b - 1/4 b + 1/12 b) 1/EJ = 1/12 b/EJ$$

$$L_{AG}^{xx} = \int_0^b (1/4 x^2/b^2) 1/EJ dx = [1/12 x^3/b^2]_0^b 1/EJ$$

$$= (1/12 b) 1/EJ = 1/12 b/EJ$$

$$L_{FG}^{xo} = \int_0^b (1/2 x^2/b^2) Fb 1/EJ dx + \int_0^b (1/2 x/b) \theta dx = [1/6 x^3/b^2]_0^b Fb 1/EJ + [1/4 x^2/b]_0^b \theta$$

$$= (1/6 b) Fb 1/EJ + (1/4 b) \theta = 5/12 Fb^2/EJ$$

$$L_{GF}^{xo} = \int_0^b (1/2 - x/b + 1/2 x^2/b^2) Fb 1/EJ dx + \int_0^b (-1/2 + 1/2 x/b) \theta dx$$

$$= [1/2 x - 1/2 x^2/b + 1/6 x^3/b^2]_0^b Fb 1/EJ + [-1/2 x + 1/4 x^2/b]_0^b \theta$$

$$= (1/2 b - 1/2 b + 1/6 b) Fb 1/EJ + (-1/2 b + 1/4 b) \theta = 5/12 Fb^2/EJ$$

$$L_{GD}^{xo} = \int_0^b (3/2 x/b - 3/2 x^2/b^2) Fb 1/EJ dx = [3/4 x^2/b - 1/2 x^3/b^2]_0^b Fb 1/EJ$$

$$= (3/4 b - 1/2 b) Fb 1/EJ = 1/4 Fb^2/EJ$$

$$L_{DG}^{xo} = \int_0^b (3/2 x/b - 3/2 x^2/b^2) Fb 1/EJ dx = [3/4 x^2/b - 1/2 x^3/b^2]_0^b Fb 1/EJ$$

$$= (3/4 b - 1/2 b) Fb 1/EJ = 1/4 Fb^2/EJ$$

$$L_{GA}^{xo} = \int_0^b (-1/2 + x/b - 1/2 x^2/b^2) Fb 1/EJ dx = [-1/2 x + 1/2 x^2/b - 1/6 x^3/b^2]_0^b Fb 1/EJ$$

$$= (-1/2 b + 1/2 b - 1/6 b) Fb 1/EJ = -1/6 Fb^2/EJ$$

$$L_{AG}^{xo} = \int_0^b (-1/2 x^2/b^2) Fb 1/EJ dx = [-1/6 x^3/b^2]_0^b Fb 1/EJ$$

$$= (-1/6 b) Fb 1/EJ = -1/6 Fb^2/EJ$$

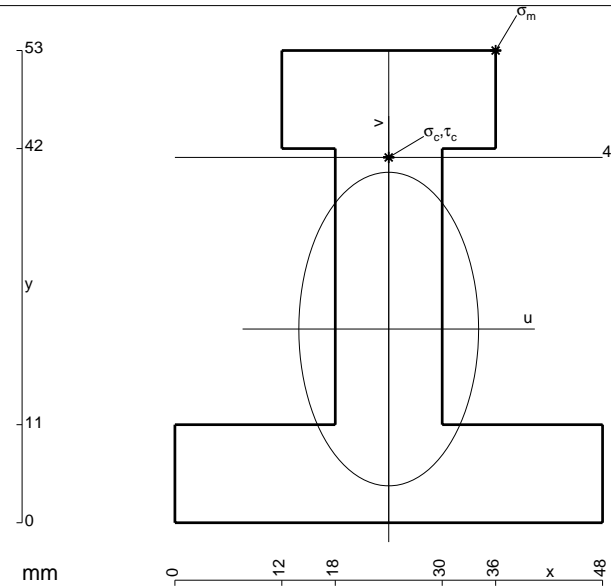

$$A = 1164. \text{ mm}^2$$

$$J_u = 360644. \text{ mm}^4$$

$$J_v = 118512. \text{ mm}^4$$

$$y_g = 21.74 \text{ mm}$$

$$T_y = -2900. \text{ N}$$

$$M_x = -2755000. \text{ Nmm}$$

$$x_m = 36. \text{ mm}$$

$$y_m = 53. \text{ mm}$$

$$u_m = 12. \text{ mm}$$

$$v_m = 31.26 \text{ mm}$$

$$\sigma_m = -Mv/J_u = 238.8 \text{ N/mm}^2$$

$$x_c = 24. \text{ mm}$$

$$y_c = 41. \text{ mm}$$

$$v_c = 19.26 \text{ mm}$$

$$\sigma_c = -Mv/J_u = 147.2 \text{ N/mm}^2$$

$$\tau_c = 4.717 \text{ N/mm}^2$$

$$\sigma_q = \sqrt{\sigma^2 + 3\tau^2} = 147.4 \text{ N/mm}^2$$

$$S = 7039. \text{ mm}^3$$

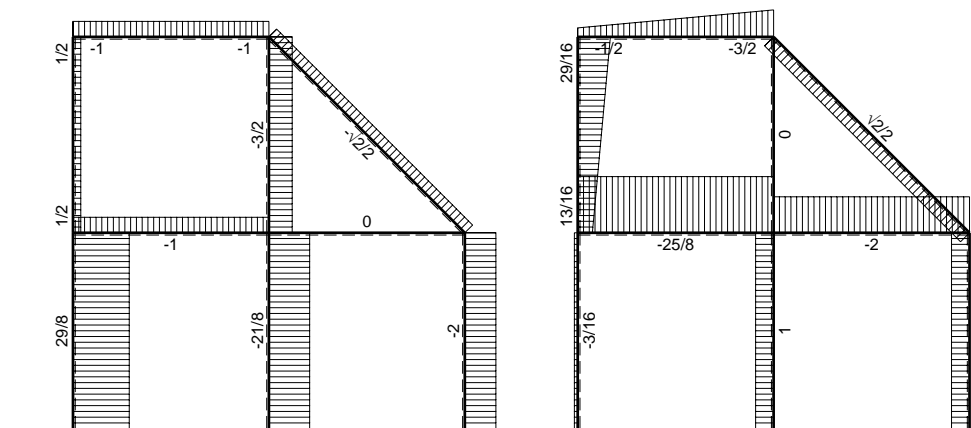
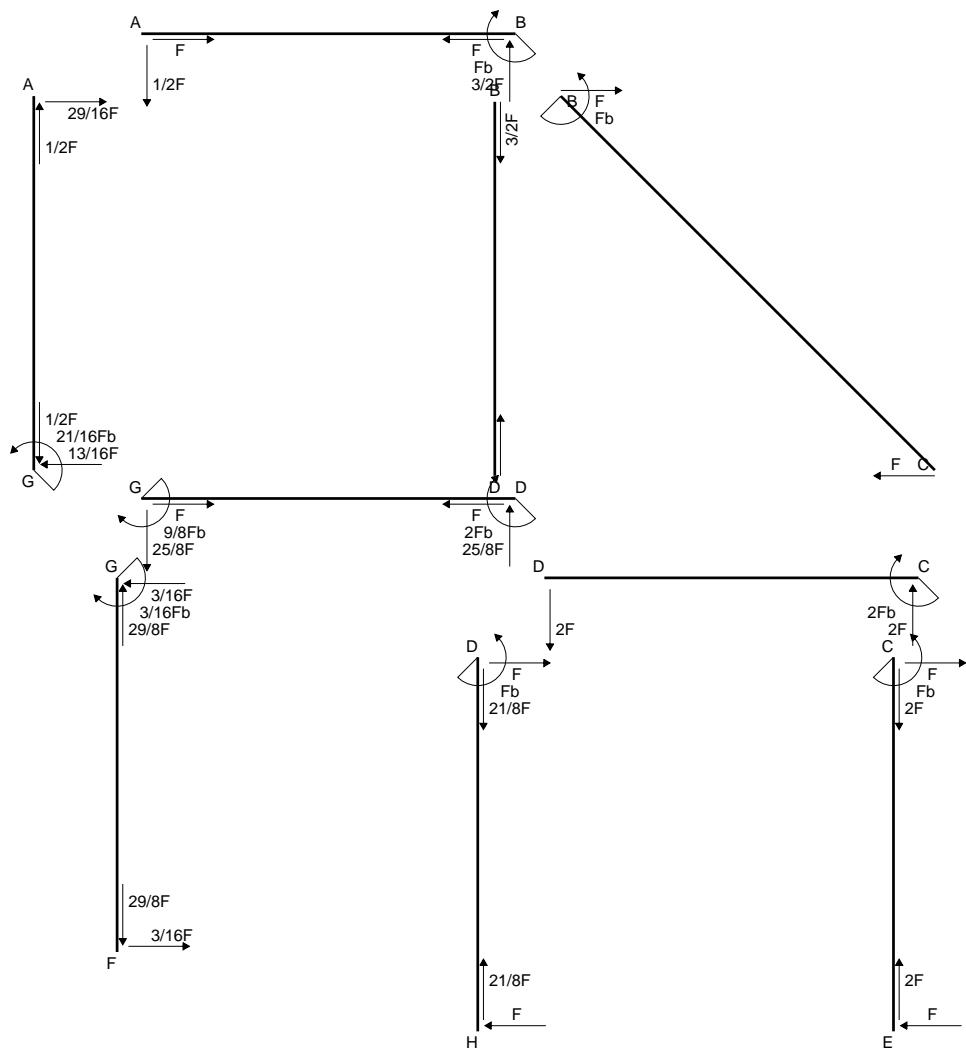

← ⊕ → F

↑ ⊕ ↓ F

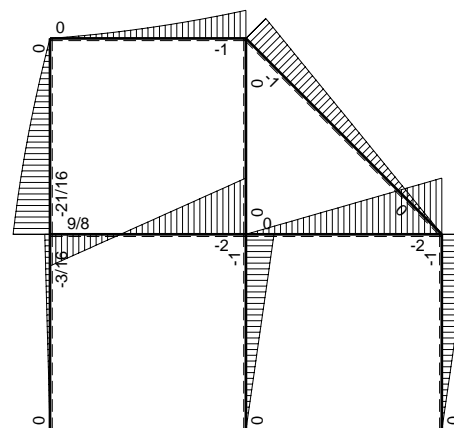

⊕ F_b

Quadro contributi PLV per iperstatica $X=W_{GD}$

→	$M_x(x)$	$M_o(x)$	θ	$M_x M_o$	$M_x \theta$	$M_x M_x$	$\int M_x(M_o/EJ+\theta)dx$	$\int X M_x M_x/EJdx$	
AB b	0	$-1/2Fx-1/2qx^2$	0	0	0	0	0+0	0	
BA b	0	$Fb-3/2Fx+1/2qx^2$	0	0	0	0	0	0	
BC $\sqrt{2}b$	0	$-Fb+\sqrt{2}/2Fx$	0	0	0	0	0	0	
BD b	0	0	0	0	0	0	0+0	0	
DB b	0	0	0	0	0	0	0	0	
DC b	0	$-2Fx$	0	0	0	0	0+0	0	
CD b	0	$2Fb-2Fx$	0	0	0	0	0	0	
CE b	0	$-Fb+Fx$	0	0	0	0	0+0	0	
EC b	0	Fx	0	0	0	0	0	0	
FG b	$-1/2x/b$	$-3/4Fx$	$-Fb/EJ$	$3/8Fx^2/b$	$1/2Fx/EJ$	$1/4x^2/b^2$	$(1/8+1/4)Fb^2/EJ$	$1/12Xb/EJ$	
GF b	$1/2-1/2x/b$	$3/4Fb-3/4Fx$	Fb/EJ	$3/8Fb-3/4Fx+3/8Fx^2/b$	$1/2Fb/EJ-1/2Fx/EJ$	$1/4-1/2x/b+1/4x^2/b^2$			
GD b	$-1+x/b$	$-2Fx$	0	$2Fx-2Fx^2/b$	0	$1-2x/b+x^2/b^2$	$(1/3+0)Fb^2/EJ$	$1/3Xb/EJ$	
DG b	x/b	$2Fb-2Fx$	0	$2Fx-2Fx^2/b$	0	x^2/b^2			
DH b	0	$-Fb+Fx$	0	0	0	0	0+0	0	
HD b	0	Fx	0	0	0	0			
GA b	$1/2-1/2x/b$	$-3/4Fb+1/4Fx+1/2qx^2$	0	$-3/8Fb+1/2Fx+1/8Fx^2/b-1/4qx^3/b$	0	$1/4-1/2x/b+1/4x^2/b^2$	$(-7/48+0)Fb^2/EJ$	$1/12Xb/EJ$	
AG b	$-1/2x/b$	$5/4Fx-1/2qx^2$	0	$-5/8Fx^2/b+1/4qx^3/b$	0	$1/4x^2/b^2$			
	totali							$9/16Fb^2/EJ$	$1/2Xb/EJ$
	iperstatica $X=W_{GD}$							$-9/8Fb$	

Sviluppi di calcolo iperstatica

$$L_{FG}^{xx} = \int_0^b (1/4 x^2/b^2) 1/EJ dx = [1/12 x^3/b^2]_0^b 1/EJ$$

$$= (1/12 b) 1/EJ = 1/12 b/EJ$$

$$L_{GF}^{xx} = \int_0^b (1/4 -1/2 x/b +1/4 x^2/b^2) 1/EJ dx = [1/4 x -1/4 x^2/b +1/12 x^3/b^2]_0^b 1/EJ$$

$$= (1/4 b -1/4 b +1/12 b) 1/EJ = 1/12 b/EJ$$

$$L_{GD}^{xx} = \int_0^b (1 -2 x/b + x^2/b^2) 1/EJ dx = [x - x^2/b +1/3 x^3/b^2]_0^b 1/EJ$$

$$= (b - b +1/3 b) 1/EJ = 1/3 b/EJ$$

$$L_{DG}^{xx} = \int_0^b (x^2/b^2) 1/EJ dx = [1/3 x^3/b^2]_0^b 1/EJ$$

$$= (1/3 b) 1/EJ = 1/3 b/EJ$$

$$L_{GA}^{xx} = \int_0^b (1/4 -1/2 x/b +1/4 x^2/b^2) 1/EJ dx = [1/4 x -1/4 x^2/b +1/12 x^3/b^2]_0^b 1/EJ$$

$$= (1/4 b -1/4 b +1/12 b) 1/EJ = 1/12 b/EJ$$

$$L_{AG}^{xx} = \int_0^b (1/4 x^2/b^2) 1/EJ dx = [1/12 x^3/b^2]_0^b 1/EJ$$

$$= (1/12 b) 1/EJ = 1/12 b/EJ$$

$$L_{FG}^{xo} = \int_0^b (3/8 x^2/b^2) Fb 1/EJ dx + \int_0^b (1/2 x/b) \theta dx = [1/8 x^3/b^2]_0^b Fb 1/EJ + [1/4 x^2/b]_0^b \theta$$

$$= (1/8 b) Fb 1/EJ + (1/4 b) \theta = 3/8 Fb^2/EJ$$

$$L_{GF}^{xo} = \int_0^b (3/8 -3/4 x/b +3/8 x^2/b^2) Fb 1/EJ dx + \int_0^b (-1/2 +1/2 x/b) \theta dx$$

$$= [3/8 x -3/8 x^2/b +1/8 x^3/b^2]_0^b Fb 1/EJ + [-1/2 x +1/4 x^2/b]_0^b \theta$$

$$= (3/8 b -3/8 b +1/8 b) Fb 1/EJ + (-1/2 b +1/4 b) \theta = 3/8 Fb^2/EJ$$

$$L_{GD}^{xo} = \int_0^b (2 x/b -2 x^2/b^2) Fb 1/EJ dx = [x^2/b -2/3 x^3/b^2]_0^b Fb 1/EJ$$

$$= (b -2/3 b) Fb 1/EJ = 1/3 Fb^2/EJ$$

$$L_{DG}^{xo} = \int_0^b (2 x/b -2 x^2/b^2) Fb 1/EJ dx = [x^2/b -2/3 x^3/b^2]_0^b Fb 1/EJ$$

$$= (b -2/3 b) Fb 1/EJ = 1/3 Fb^2/EJ$$

$$L_{GA}^{xo} = \int_0^b (-3/8 +1/2 x/b +1/8 x^2/b^2 -1/4 x^3/b^3) Fb 1/EJ dx$$

$$= [-3/8 x +1/4 x^2/b +1/24 x^3/b^2 -1/16 x^4/b^3]_0^b Fb 1/EJ$$

$$= (-3/8 b +1/4 b +1/24 b -1/16 b) Fb 1/EJ = -7/48 Fb^2/EJ$$

$$L_{AG}^{xo} = \int_0^b (-5/8 x^2/b^2 +1/4 x^3/b^3) Fb 1/EJ dx = [-5/24 x^3/b^2 +1/16 x^4/b^3]_0^b Fb 1/EJ$$

$$= (-5/24 b +1/16 b) Fb 1/EJ = -7/48 Fb^2/EJ$$

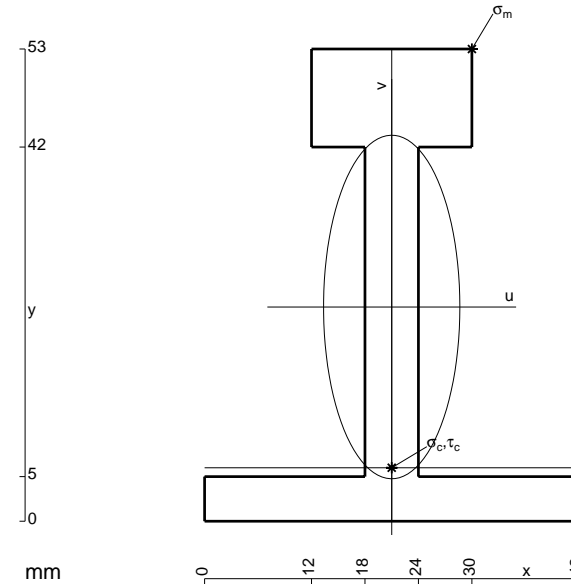

- A = 630. mm²
- J_u = 234233. mm⁴
- J_v = 36882. mm⁴
- y_g = 24.04 mm
- T_y = -3220. N
- M_x = -1610000. Nmm
- x_m = 30. mm
- y_m = 53. mm
- u_m = 9. mm
- v_m = 28.96 mm
- σ_m = -Mv/J_u = 199. N/mm²
- x_c = 21. mm
- y_c = 6. mm
- v_c = -18.04 mm
- σ_c = -Mv/J_u = -124. N/mm²
- τ_c = 10.62 N/mm²
- σ_o = √σ²+3τ² = 125.4 N/mm²
- S = 4635. mm³

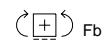
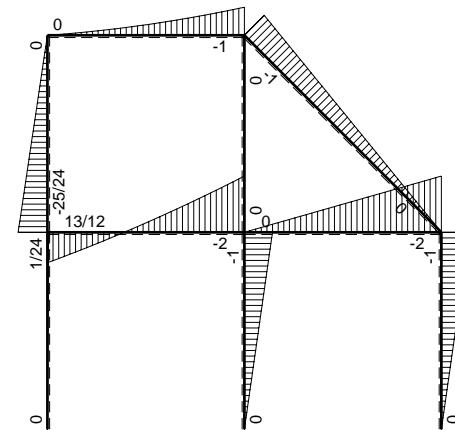
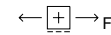
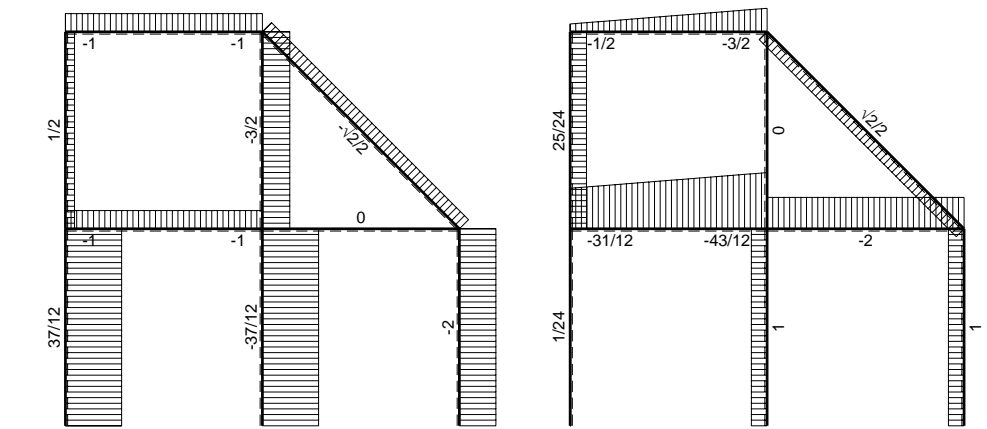
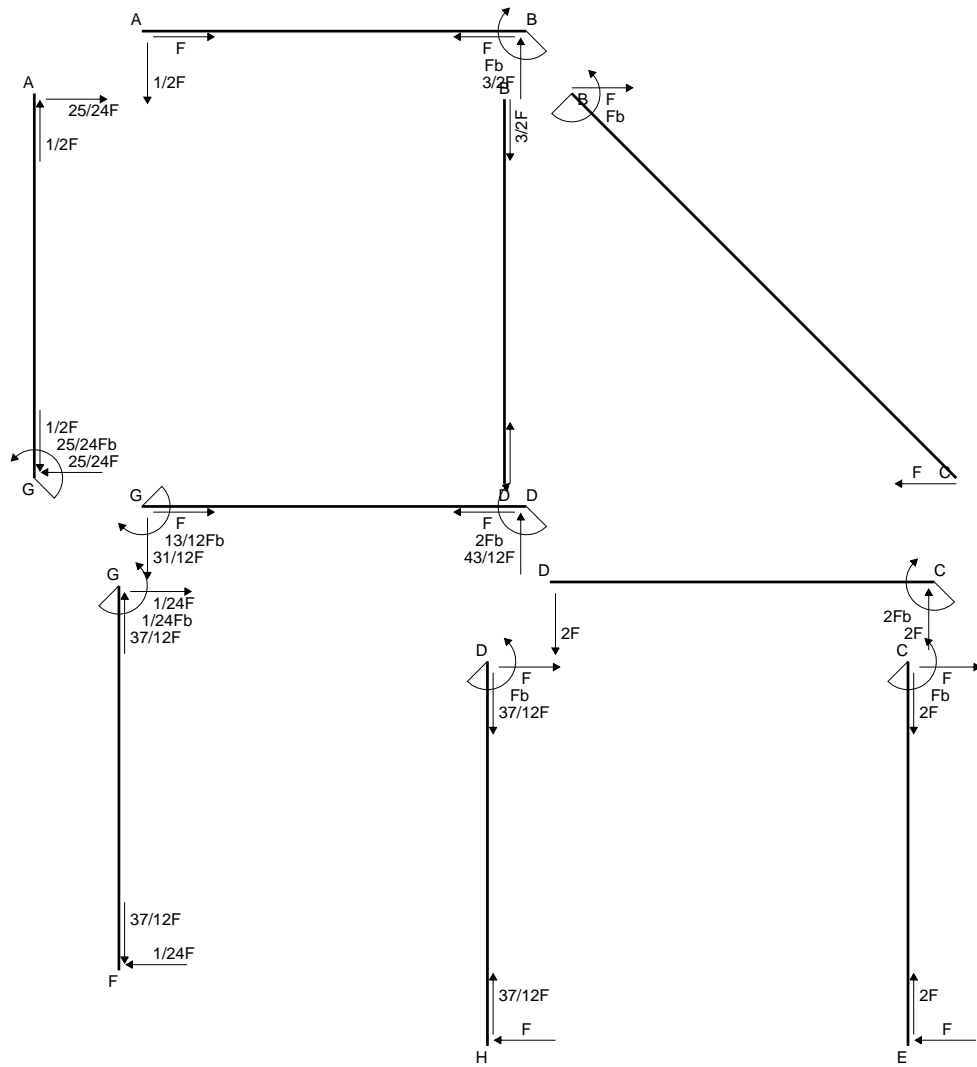

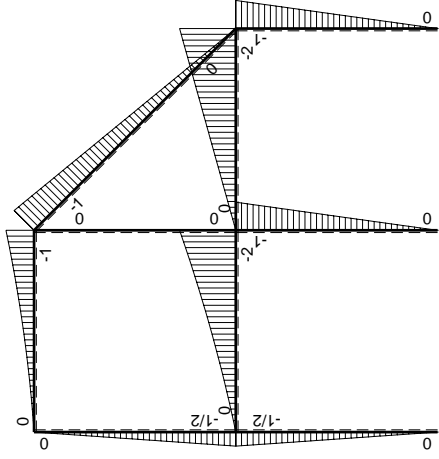
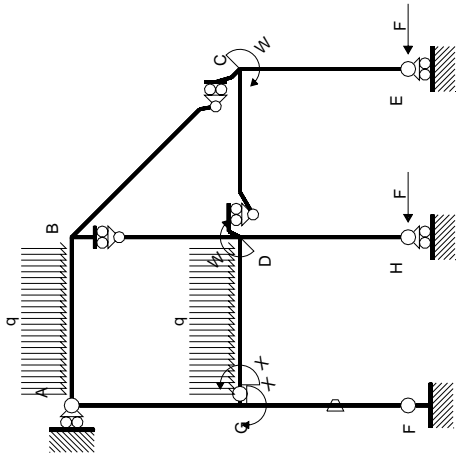

Schema di calcolo iperstatico

M_0 flessione da carichi assegnati

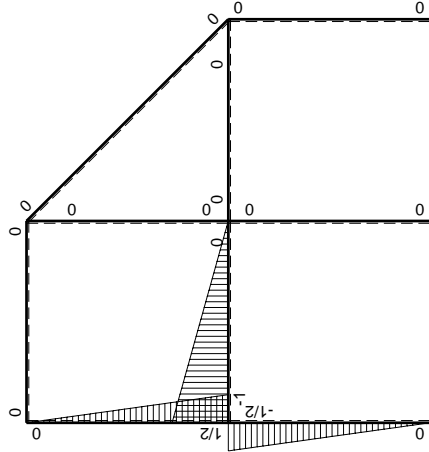

M_x flessione da iperstatica $X=1$

Quadro contributi PLV per iperstatica $X=W_{GD}$

→	$M_x(x)$	$M_o(x)$	θ	$M_x M_o$	$M_x \theta$	$M_x M_x$	$\int M_x(M_o/EJ+\theta)dx$	$\int X M_x M_x/EJdx$
AB b	0	$-1/2Fx-1/2qx^2$	0	0	0	0	0+0	0
BA b	0	$Fb-3/2Fx+1/2qx^2$	0	0	0	0	0	0
BC $\sqrt{2}b$	0	$-Fb+\sqrt{2}/2Fx$	0	0	0	0	0	0
BD b	0	0	0	0	0	0	0+0	0
DB b	0	0	0	0	0	0	0	0
DC b	0	$-2Fx$	0	0	0	0	0+0	0
CD b	0	$2Fb-2Fx$	0	0	0	0	0	0
CE b	0	$-Fb+Fx$	0	0	0	0	0+0	0
EC b	0	Fx	0	0	0	0	0	0
FG b	$-1/2x/b$	$-1/2Fx$	$-Fb/EJ$	$1/4Fx^2/b$	$1/2Fx/EJ$	$1/4x^2/b^2$	$(1/12+1/4)Fb^2/EJ$	$1/12Xb/EJ$
GF b	$1/2-1/2x/b$	$1/2Fb-1/2Fx$	Fb/EJ	$1/4Fb-1/2Fx+1/4Fx^2/b$	$1/2Fb/EJ-1/2Fx/EJ$	$1/4-1/2x/b+1/4x^2/b^2$		
GD b	$-1+x/b$	$-3/2Fx-1/2qx^2$	0	$3/2Fx-Fx^2/b-1/2qx^3/b$	0	$1-2x/b+x^2/b^2$	$(7/24+0)Fb^2/EJ$	$1/3Xb/EJ$
DG b	x/b	$2Fb-5/2Fx+1/2qx^2$	0	$2Fx-5/2Fx^2/b+1/2qx^3/b$	0	x^2/b^2		
DH b	0	$-Fb+Fx$	0	0	0	0	0+0	0
HD b	0	Fx	0	0	0	0	0	0
GA b	$1/2-1/2x/b$	$-1/2Fb+1/2Fx$	0	$-1/4Fb+1/2Fx-1/4Fx^2/b$	0	$1/4-1/2x/b+1/4x^2/b^2$	$(-1/12+0)Fb^2/EJ$	$1/12Xb/EJ$
AG b	$-1/2x/b$	$1/2Fx$	0	$-1/4Fx^2/b$	0	$1/4x^2/b^2$		
	totali						$13/24Fb^2/EJ$	$1/2Xb/EJ$
	iperstatica $X=W_{GD}$						$-13/12Fb$	

Sviluppi di calcolo iperstatica

$$L_{FG}^{xx} = \int_0^b (1/4 x^2/b^2) 1/EJ dx = [1/12 x^3/b^2]_0^b 1/EJ$$

$$= (1/12 b) 1/EJ = 1/12 b/EJ$$

$$L_{GF}^{xx} = \int_0^b (1/4 - 1/2 x/b + 1/4 x^2/b^2) 1/EJ dx = [1/4 x - 1/4 x^2/b + 1/12 x^3/b^2]_0^b 1/EJ$$

$$= (1/4 b - 1/4 b + 1/12 b) 1/EJ = 1/12 b/EJ$$

$$L_{GD}^{xx} = \int_0^b (1 - 2 x/b + x^2/b^2) 1/EJ dx = [x - x^2/b + 1/3 x^3/b^2]_0^b 1/EJ$$

$$= (b - b + 1/3 b) 1/EJ = 1/3 b/EJ$$

$$L_{DG}^{xx} = \int_0^b (x^2/b^2) 1/EJ dx = [1/3 x^3/b^2]_0^b 1/EJ$$

$$= (1/3 b) 1/EJ = 1/3 b/EJ$$

$$L_{GA}^{xx} = \int_0^b (1/4 - 1/2 x/b + 1/4 x^2/b^2) 1/EJ dx = [1/4 x - 1/4 x^2/b + 1/12 x^3/b^2]_0^b 1/EJ$$

$$= (1/4 b - 1/4 b + 1/12 b) 1/EJ = 1/12 b/EJ$$

$$L_{AG}^{xx} = \int_0^b (1/4 x^2/b^2) 1/EJ dx = [1/12 x^3/b^2]_0^b 1/EJ$$

$$= (1/12 b) 1/EJ = 1/12 b/EJ$$

$$L_{FG}^{xo} = \int_0^b (1/4 x^2/b^2) Fb 1/EJ dx + \int_0^b (1/2 x/b) \theta dx = [1/12 x^3/b^2]_0^b Fb 1/EJ + [1/4 x^2/b]_0^b \theta$$

$$= (1/12 b) Fb 1/EJ + (1/4 b) \theta = 1/3 Fb^2/EJ$$

$$L_{GF}^{xo} = \int_0^b (1/4 - 1/2 x/b + 1/4 x^2/b^2) Fb 1/EJ dx + \int_0^b (-1/2 + 1/2 x/b) \theta dx$$

$$= [1/4 x - 1/4 x^2/b + 1/12 x^3/b^2]_0^b Fb 1/EJ + [-1/2 x + 1/4 x^2/b]_0^b \theta$$

$$= (1/4 b - 1/4 b + 1/12 b) Fb 1/EJ + (-1/2 b + 1/4 b) \theta = 1/3 Fb^2/EJ$$

$$L_{GD}^{xo} = \int_0^b (3/2 x/b - x^2/b^2 - 1/2 x^3/b^3) Fb 1/EJ dx = [3/4 x^2/b - 1/3 x^3/b^2 - 1/8 x^4/b^3]_0^b Fb 1/EJ$$

$$= (3/4 b - 1/3 b - 1/8 b) Fb 1/EJ = 7/24 Fb^2/EJ$$

$$L_{DG}^{xo} = \int_0^b (2 x/b - 5/2 x^2/b^2 + 1/2 x^3/b^3) Fb 1/EJ dx = [x^2/b - 5/6 x^3/b^2 + 1/8 x^4/b^3]_0^b Fb 1/EJ$$

$$= (b - 5/6 b + 1/8 b) Fb 1/EJ = 7/24 Fb^2/EJ$$

$$L_{GA}^{xo} = \int_0^b (-1/4 + 1/2 x/b - 1/4 x^2/b^2) Fb 1/EJ dx = [-1/4 x + 1/4 x^2/b - 1/12 x^3/b^2]_0^b Fb 1/EJ$$

$$= (-1/4 b + 1/4 b - 1/12 b) Fb 1/EJ = -1/12 Fb^2/EJ$$

$$L_{AG}^{xo} = \int_0^b (-1/4 x^2/b^2) Fb 1/EJ dx = [-1/12 x^3/b^2]_0^b Fb 1/EJ$$

$$= (-1/12 b) Fb 1/EJ = -1/12 Fb^2/EJ$$

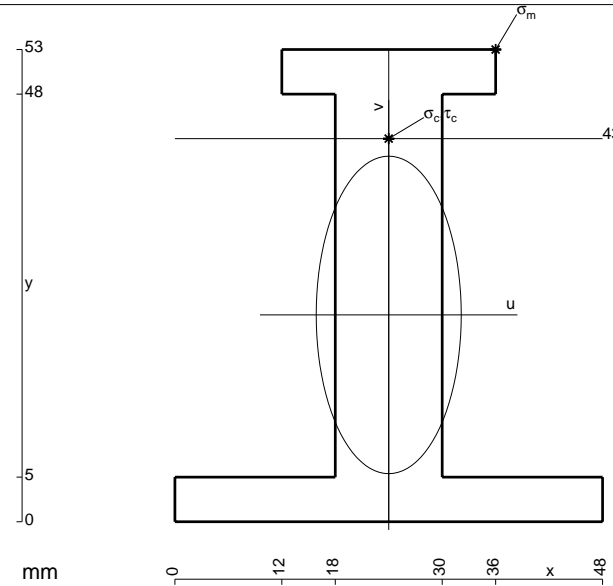

- A = 876. mm²
- J_u = 278149. mm⁴
- J_v = 58032. mm⁴
- y_g = 23.21 mm
- T_y = -3560. N
- M_x = -1958000. Nmm
- x_m = 36. mm
- y_m = 53. mm
- u_m = 12. mm
- v_m = 29.79 mm
- σ_m = -Mv/J_u = 209.7 N/mm²
- x_c = 24. mm
- y_c = 43. mm
- v_c = 19.79 mm
- σ_c = -Mv/J_u = 139.3 N/mm²
- τ_c = 4.919 N/mm²
- σ_q = √σ²+3τ² = 139.6 N/mm²
- S = 4612. mm³

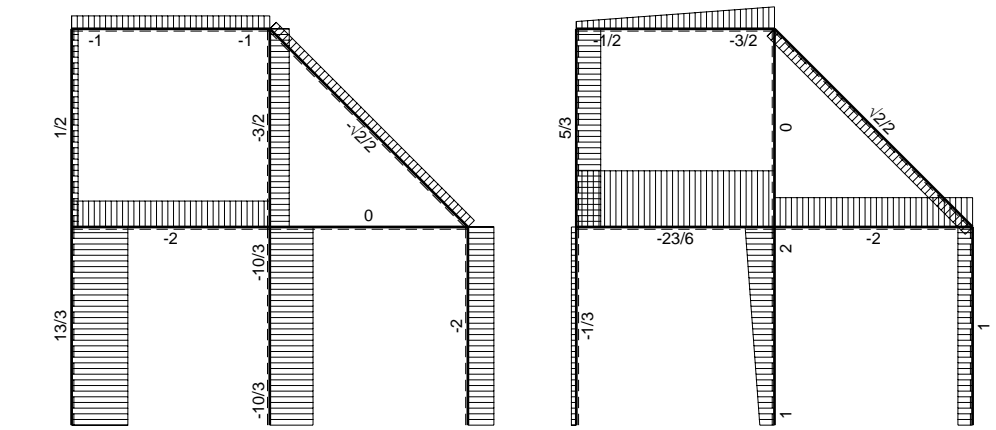
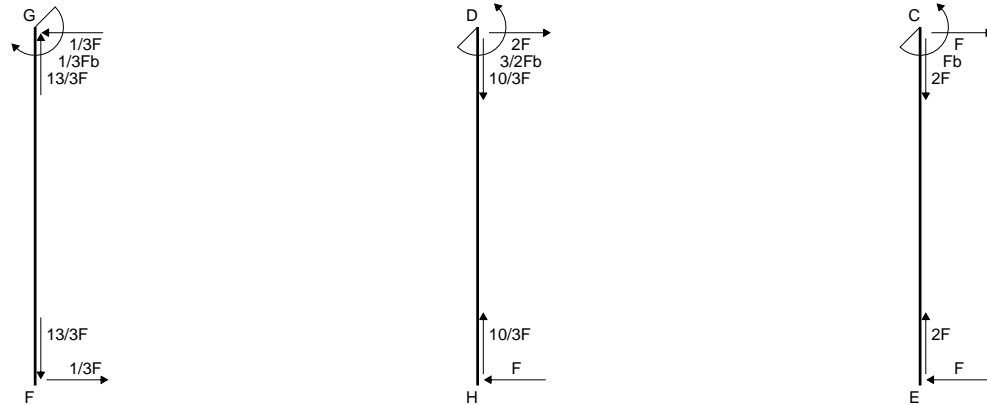
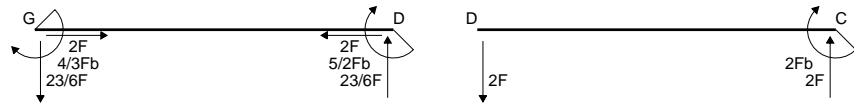
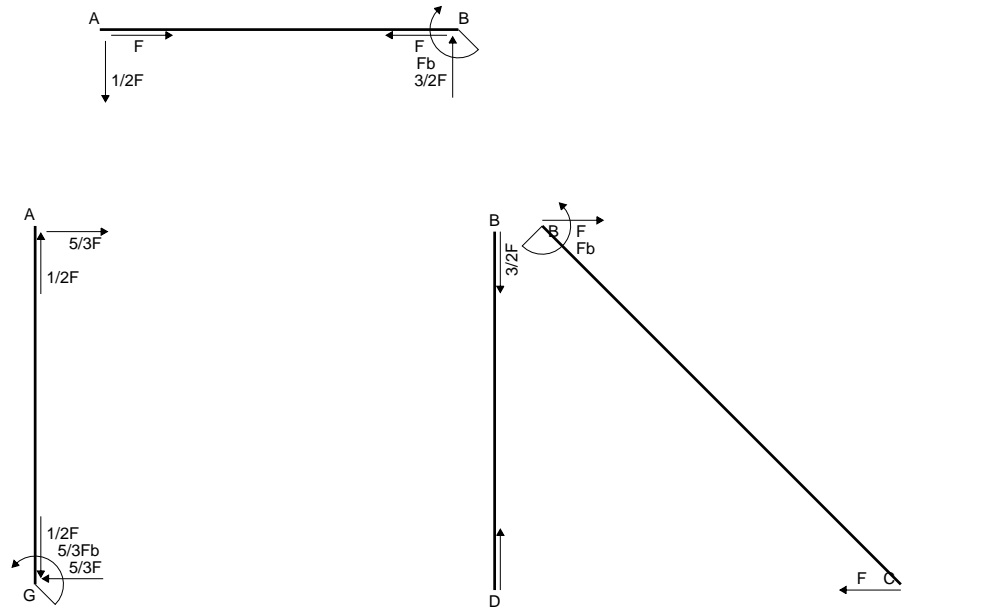

← ⊕ → F

↑ ⊕ ↓ F

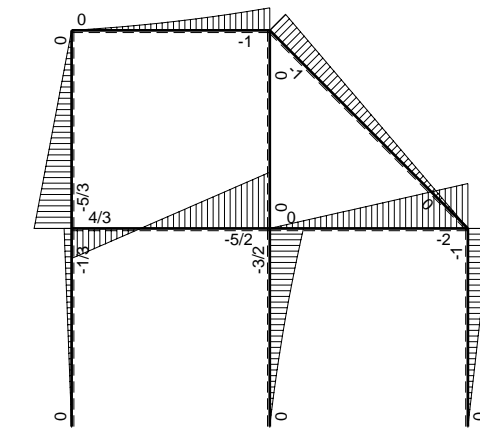

⊕ ⊖ Fb

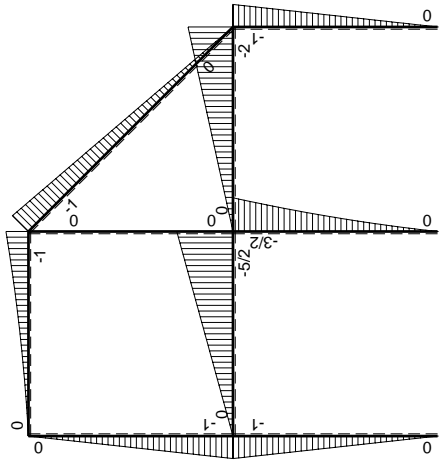
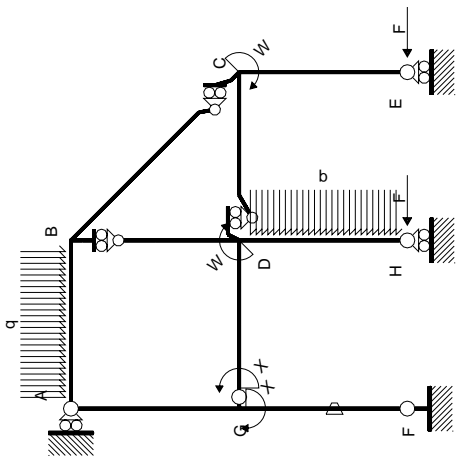

Schema di calcolo iperstatico

M_0 , flessione da carichi assegnati

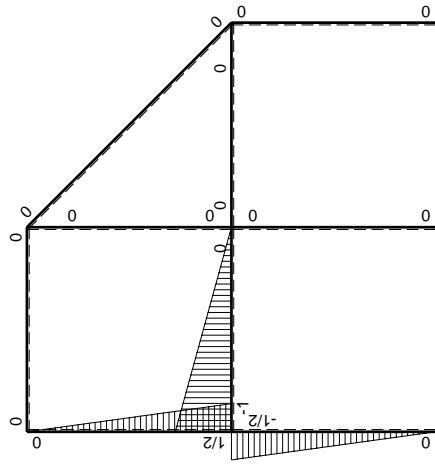

M_x , flessione da iperstatica $X=1$

Quadro contributi PLV per iperstatica $X=W_{GD}$

→	$M_x(x)$	$M_o(x)$	θ	$M_x M_o$	$M_x \theta$	$M_x M_x$	$\int M_x(M_o/EJ+\theta)dx$	$\int X M_x M_x/EJ dx$
AB b	0	$-1/2Fx-1/2qx^2$	0	0	0	0	0+0	0
BA b	0	$Fb-3/2Fx+1/2qx^2$	0	0	0	0	0	0
BC $\sqrt{2}b$	0	$-Fb+\sqrt{2}/2Fx$	0	0	0	0	0	0
BD b	0	0	0	0	0	0	0+0	0
DB b	0	0	0	0	0	0	0	0
DC b	0	$-2Fx$	0	0	0	0	0+0	0
CD b	0	$2Fb-2Fx$	0	0	0	0	0	0
CE b	0	$-Fb+Fx$	0	0	0	0	0+0	0
EC b	0	Fx	0	0	0	0	0	0
FG b	$-1/2x/b$	$-Fx$	$-Fb/EJ$	$1/2Fx^2/b$	$1/2Fx/EJ$	$1/4x^2/b^2$	$(1/6+1/4)Fb^2/EJ$	$1/12Xb/EJ$
GF b	$1/2-1/2x/b$	$Fb-Fx$	Fb/EJ	$1/2Fb-Fx+1/2Fx^2/b$	$1/2Fb/EJ-1/2Fx/EJ$	$1/4-1/2x/b+1/4x^2/b^2$		
GD b	$-1+x/b$	$-5/2Fx$	0	$5/2Fx-5/2Fx^2/b$	0	$1-2x/b+x^2/b^2$	$(5/12+0)Fb^2/EJ$	$1/3Xb/EJ$
DG b	x/b	$5/2Fb-5/2Fx$	0	$5/2Fx-5/2Fx^2/b$	0	x^2/b^2		
DH b	0	$-3/2Fb+2Fx-1/2qx^2$	0	0	0	0	0+0	0
HD b	0	$Fx+1/2qx^2$	0	0	0	0	0	0
GA b	$1/2-1/2x/b$	$-Fb+Fx$	0	$-1/2Fb+Fx-1/2Fx^2/b$	0	$1/4-1/2x/b+1/4x^2/b^2$	$(-1/6+0)Fb^2/EJ$	$1/12Xb/EJ$
AG b	$-1/2x/b$	Fx	0	$-1/2Fx^2/b$	0	$1/4x^2/b^2$		
	totali						$2/3Fb^2/EJ$	$1/2Xb/EJ$
	iperstatica $X=W_{GD}$						$-4/3Fb$	

Sviluppi di calcolo iperstatica

$$L_{FG}^{xx} = \int_0^b (1/4 x^2/b^2) 1/EJ dx = [1/12 x^3/b^2]_0^b 1/EJ$$

$$= (1/12 b) 1/EJ = 1/12 b/EJ$$

$$L_{GF}^{xx} = \int_0^b (1/4 - 1/2 x/b + 1/4 x^2/b^2) 1/EJ dx = [1/4 x - 1/4 x^2/b + 1/12 x^3/b^2]_0^b 1/EJ$$

$$= (1/4 b - 1/4 b + 1/12 b) 1/EJ = 1/12 b/EJ$$

$$L_{GD}^{xx} = \int_0^b (1 - 2 x/b + x^2/b^2) 1/EJ dx = [x - x^2/b + 1/3 x^3/b^2]_0^b 1/EJ$$

$$= (b - b + 1/3 b) 1/EJ = 1/3 b/EJ$$

$$L_{DG}^{xx} = \int_0^b (x^2/b^2) 1/EJ dx = [1/3 x^3/b^2]_0^b 1/EJ$$

$$= (1/3 b) 1/EJ = 1/3 b/EJ$$

$$L_{GA}^{xx} = \int_0^b (1/4 - 1/2 x/b + 1/4 x^2/b^2) 1/EJ dx = [1/4 x - 1/4 x^2/b + 1/12 x^3/b^2]_0^b 1/EJ$$

$$= (1/4 b - 1/4 b + 1/12 b) 1/EJ = 1/12 b/EJ$$

$$L_{AG}^{xx} = \int_0^b (1/4 x^2/b^2) 1/EJ dx = [1/12 x^3/b^2]_0^b 1/EJ$$

$$= (1/12 b) 1/EJ = 1/12 b/EJ$$

$$L_{FG}^{xo} = \int_0^b (1/2 x^2/b^2) Fb 1/EJ dx + \int_0^b (1/2 x/b) \theta dx = [1/6 x^3/b^2]_0^b Fb 1/EJ + [1/4 x^2/b]_0^b \theta$$

$$= (1/6 b) Fb 1/EJ + (1/4 b) \theta = 5/12 Fb^2/EJ$$

$$L_{GF}^{xo} = \int_0^b (1/2 - x/b + 1/2 x^2/b^2) Fb 1/EJ dx + \int_0^b (-1/2 + 1/2 x/b) \theta dx$$

$$= [1/2 x - 1/2 x^2/b + 1/6 x^3/b^2]_0^b Fb 1/EJ + [-1/2 x + 1/4 x^2/b]_0^b \theta$$

$$= (1/2 b - 1/2 b + 1/6 b) Fb 1/EJ + (-1/2 b + 1/4 b) \theta = 5/12 Fb^2/EJ$$

$$L_{GD}^{xo} = \int_0^b (5/2 x/b - 5/2 x^2/b^2) Fb 1/EJ dx = [5/4 x^2/b - 5/6 x^3/b^2]_0^b Fb 1/EJ$$

$$= (5/4 b - 5/6 b) Fb 1/EJ = 5/12 Fb^2/EJ$$

$$L_{DG}^{xo} = \int_0^b (5/2 x/b - 5/2 x^2/b^2) Fb 1/EJ dx = [5/4 x^2/b - 5/6 x^3/b^2]_0^b Fb 1/EJ$$

$$= (5/4 b - 5/6 b) Fb 1/EJ = 5/12 Fb^2/EJ$$

$$L_{GA}^{xo} = \int_0^b (-1/2 + x/b - 1/2 x^2/b^2) Fb 1/EJ dx = [-1/2 x + 1/2 x^2/b - 1/6 x^3/b^2]_0^b Fb 1/EJ$$

$$= (-1/2 b + 1/2 b - 1/6 b) Fb 1/EJ = -1/6 Fb^2/EJ$$

$$L_{AG}^{xo} = \int_0^b (-1/2 x^2/b^2) Fb 1/EJ dx = [-1/6 x^3/b^2]_0^b Fb 1/EJ$$

$$= (-1/6 b) Fb 1/EJ = -1/6 Fb^2/EJ$$

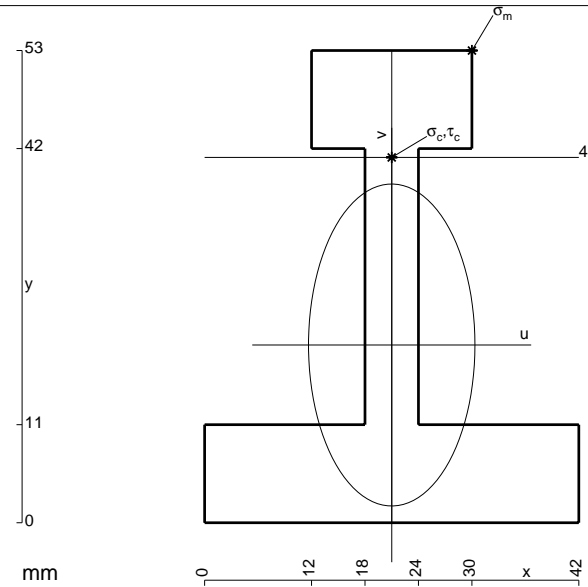

$$A = 846. \text{ mm}^2$$

$$J_u = 276280. \text{ mm}^4$$

$$J_v = 73818. \text{ mm}^4$$

$$y_g = 19.95 \text{ mm}$$

$$T_y = -3060. \text{ N}$$

$$M_x = -1836000. \text{ Nmm}$$

$$x_m = 30. \text{ mm}$$

$$y_m = 53. \text{ mm}$$

$$u_m = 9. \text{ mm}$$

$$v_m = 33.05 \text{ mm}$$

$$\sigma_m = -Mv/J_u = 219.7 \text{ N/mm}^2$$

$$x_c = 21. \text{ mm}$$

$$y_c = 41. \text{ mm}$$

$$v_c = 21.05 \text{ mm}$$

$$\sigma_c = -Mv/J_u = 139.9 \text{ N/mm}^2$$

$$\tau_c = 10.31 \text{ N/mm}^2$$

$$\sigma_\rho = \sqrt{\sigma^2 + 3\tau^2} = 141. \text{ N/mm}^2$$

$$S = 5585. \text{ mm}^3$$

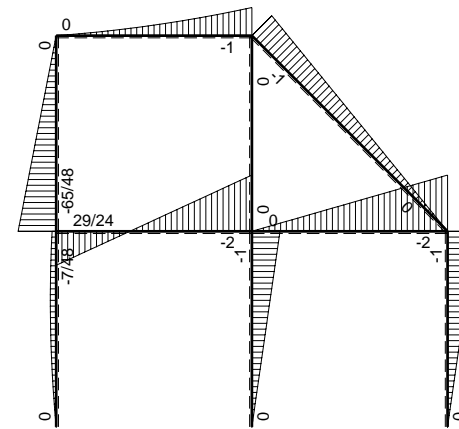
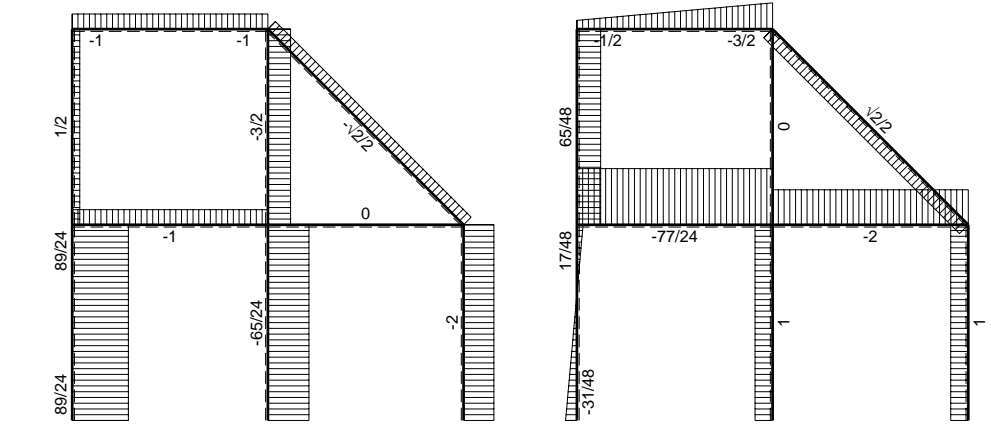
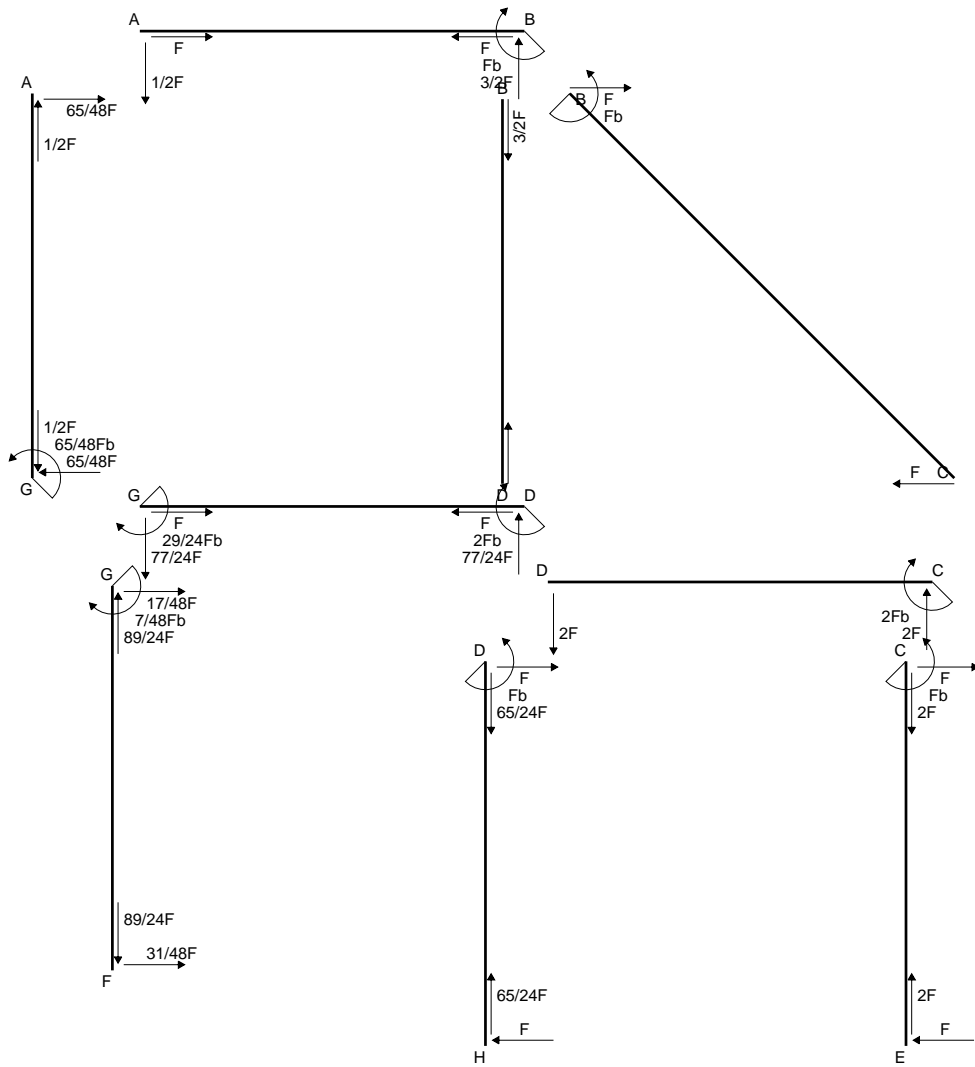

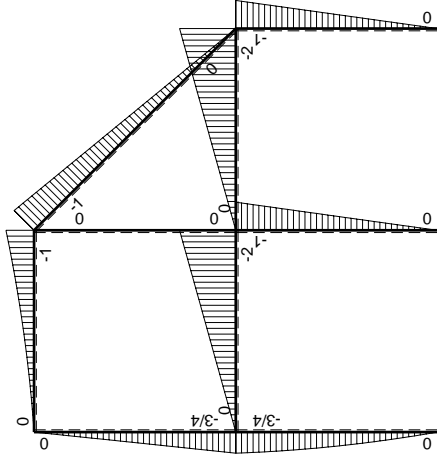
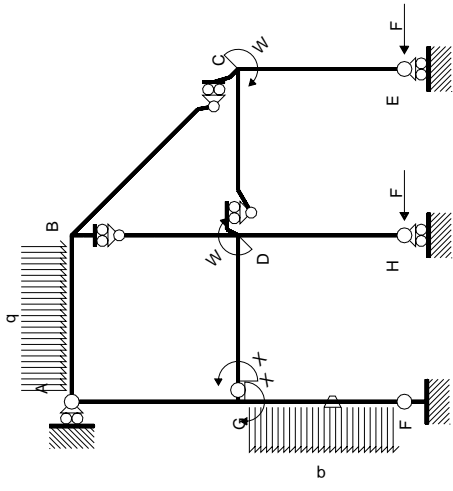

Schema di calcolo iperstatico

M_0 flessione da carichi assegnati



M_x flessione da iperstatica $X=1$

Quadro contributi PLV per iperstatica $X=W_{GD}$

→	$M_x(x)$	$M_o(x)$	θ	$M_x M_o$	$M_x \theta$	$M_x M_x$	$\int M_x(M_o/EJ+\theta)dx$	$\int x M_x M_x/EJ dx$
AB b	0	$-1/2Fx-1/2qx^2$	0	0	0	0	0+0	0
BA b	0	$Fb-3/2Fx+1/2qx^2$	0	0	0	0		
BC $\sqrt{2}b$	0	$-Fb+\sqrt{2}/2Fx$	0	0	0	0	0	0
BD b	0	0	0	0	0	0	0+0	0
DB b	0	0	0	0	0	0		
DC b	0	$-2Fx$	0	0	0	0	0+0	0
CD b	0	$2Fb-2Fx$	0	0	0	0		
CE b	0	$-Fb+Fx$	0	0	0	0	0+0	0
EC b	0	Fx	0	0	0	0		
FG b	$-1/2x/b$	$-5/4Fx+1/2qx^2$	$-Fb/EJ$	$5/8Fx^2/b-1/4qx^3/b$	$1/2Fx/EJ$	$1/4x^2/b^2$	$(7/48+1/4)Fb^2/EJ$	$1/12Xb/EJ$
GF b	$1/2-1/2x/b$	$3/4Fb-1/4Fx-1/2qx^2$	Fb/EJ	$3/8Fb-1/2Fx-1/8Fx^2/b+1/4qx^3/b$	$1/2Fb/EJ-1/2Fx/EJ$	$1/4-1/2x/b+1/4x^2/b^2$		
GD b	$-1+x/b$	$-2Fx$	0	$2Fx-2Fx^2/b$	0	$1-2x/b+x^2/b^2$	$(1/3+0)Fb^2/EJ$	$1/3Xb/EJ$
DG b	x/b	$2Fb-2Fx$	0	$2Fx-2Fx^2/b$	0	x^2/b^2		
DH b	0	$-Fb+Fx$	0	0	0	0	0+0	0
HD b	0	Fx	0	0	0	0		
GA b	$1/2-1/2x/b$	$-3/4Fb+3/4Fx$	0	$-3/8Fb+3/4Fx-3/8Fx^2/b$	0	$1/4-1/2x/b+1/4x^2/b^2$	$(-1/8+0)Fb^2/EJ$	$1/12Xb/EJ$
AG b	$-1/2x/b$	$3/4Fx$	0	$-3/8Fx^2/b$	0	$1/4x^2/b^2$		
	totali						$29/48Fb^2/EJ$	$1/2Xb/EJ$
	iperstatica $X=W_{GD}$						$-29/24Fb$	

Sviluppi di calcolo iperstatica

$$L_{FG}^{xx} = \int_0^b (1/4 x^2/b^2) 1/EJ dx = [1/12 x^3/b^2]_0^b 1/EJ$$

$$= (1/12 b) 1/EJ = 1/12 b/EJ$$

$$L_{GF}^{xx} = \int_0^b (1/4 - 1/2 x/b + 1/4 x^2/b^2) 1/EJ dx = [1/4 x - 1/4 x^2/b + 1/12 x^3/b^2]_0^b 1/EJ$$

$$= (1/4 b - 1/4 b + 1/12 b) 1/EJ = 1/12 b/EJ$$

$$L_{GD}^{xx} = \int_0^b (1 - 2 x/b + x^2/b^2) 1/EJ dx = [x - x^2/b + 1/3 x^3/b^2]_0^b 1/EJ$$

$$= (b - b + 1/3 b) 1/EJ = 1/3 b/EJ$$

$$L_{DG}^{xx} = \int_0^b (x^2/b^2) 1/EJ dx = [1/3 x^3/b^2]_0^b 1/EJ$$

$$= (1/3 b) 1/EJ = 1/3 b/EJ$$

$$L_{GA}^{xx} = \int_0^b (1/4 - 1/2 x/b + 1/4 x^2/b^2) 1/EJ dx = [1/4 x - 1/4 x^2/b + 1/12 x^3/b^2]_0^b 1/EJ$$

$$= (1/4 b - 1/4 b + 1/12 b) 1/EJ = 1/12 b/EJ$$

$$L_{AG}^{xx} = \int_0^b (1/4 x^2/b^2) 1/EJ dx = [1/12 x^3/b^2]_0^b 1/EJ$$

$$= (1/12 b) 1/EJ = 1/12 b/EJ$$

$$L_{FG}^{xo} = \int_0^b (5/8 x^2/b^2 - 1/4 x^3/b^3) Fb 1/EJ dx + \int_0^b (1/2 x/b) \theta dx$$

$$= [5/24 x^3/b^2 - 1/16 x^4/b^3]_0^b Fb 1/EJ + [1/4 x^2/b]_0^b \theta$$

$$= (5/24 b - 1/16 b) Fb 1/EJ + (1/4 b) \theta = 19/48 Fb^2/EJ$$

$$L_{GF}^{xo} = \int_0^b (3/8 - 1/2 x/b - 1/8 x^2/b^2 + 1/4 x^3/b^3) Fb 1/EJ dx + \int_0^b (-1/2 + 1/2 x/b) \theta dx$$

$$= [3/8 x - 1/4 x^2/b - 1/24 x^3/b^2 + 1/16 x^4/b^3]_0^b Fb 1/EJ + [-1/2 x + 1/4 x^2/b]_0^b \theta$$

$$= (3/8 b - 1/4 b - 1/24 b + 1/16 b) Fb 1/EJ + (-1/2 b + 1/4 b) \theta = 19/48 Fb^2/EJ$$

$$L_{GD}^{xo} = \int_0^b (2 x/b - 2 x^2/b^2) Fb 1/EJ dx = [x^2/b - 2/3 x^3/b^2]_0^b Fb 1/EJ$$

$$= (b - 2/3 b) Fb 1/EJ = 1/3 Fb^2/EJ$$

$$L_{DG}^{xo} = \int_0^b (2 x/b - 2 x^2/b^2) Fb 1/EJ dx = [x^2/b - 2/3 x^3/b^2]_0^b Fb 1/EJ$$

$$= (b - 2/3 b) Fb 1/EJ = 1/3 Fb^2/EJ$$

$$L_{GA}^{xo} = \int_0^b (-3/8 + 3/4 x/b - 3/8 x^2/b^2) Fb 1/EJ dx = [-3/8 x + 3/8 x^2/b - 1/8 x^3/b^2]_0^b Fb 1/EJ$$

$$= (-3/8 b + 3/8 b - 1/8 b) Fb 1/EJ = -1/8 Fb^2/EJ$$

$$L_{AG}^{xo} = \int_0^b (-3/8 x^2/b^2) Fb 1/EJ dx = [-1/8 x^3/b^2]_0^b Fb 1/EJ$$

$$= (-1/8 b) Fb 1/EJ = -1/8 Fb^2/EJ$$

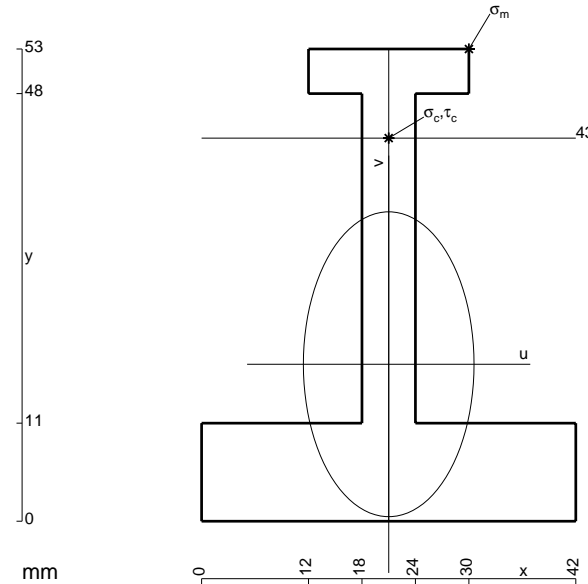

- A = 774. mm²
- J_u = 226668. mm⁴
- J_v = 71010. mm⁴
- y_g = 17.62 mm
- T_y = -2260. N
- M_x = -1469000. Nmm
- x_m = 30. mm
- y_m = 53. mm
- u_m = 9. mm
- v_m = 35.38 mm
- σ_m = -M_v/J_u = 229.3 N/mm²
- x_c = 21. mm
- y_c = 43. mm
- v_c = 25.38 mm
- σ_c = -M_v/J_u = 164.5 N/mm²
- τ_c = 6.308 N/mm²
- σ_o = √σ²+3τ² = 164.9 N/mm²
- S = 3796. mm³

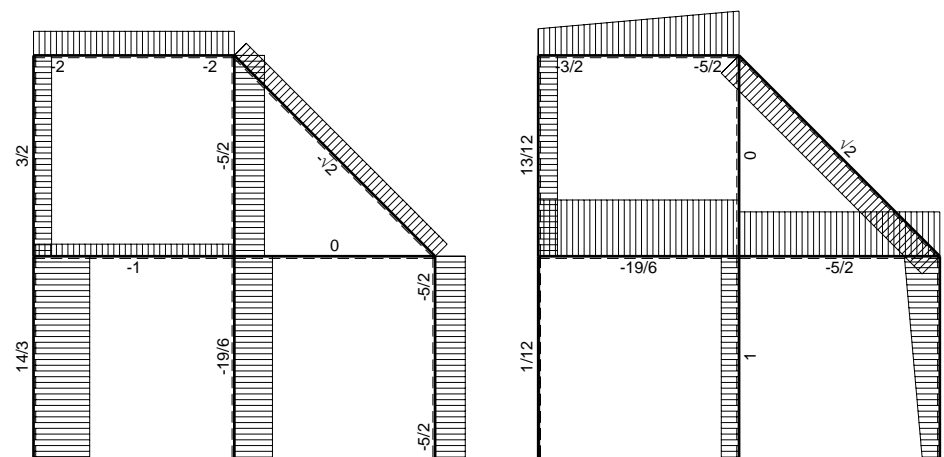
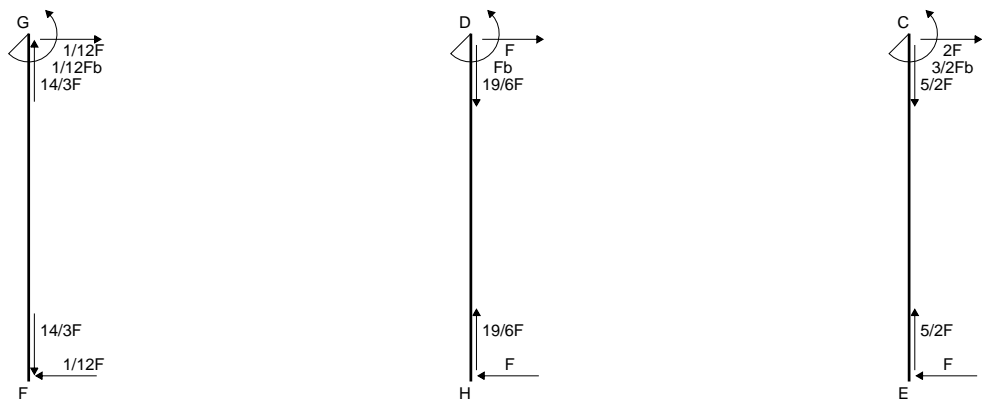
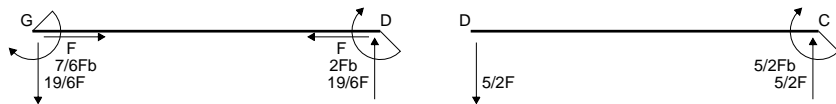
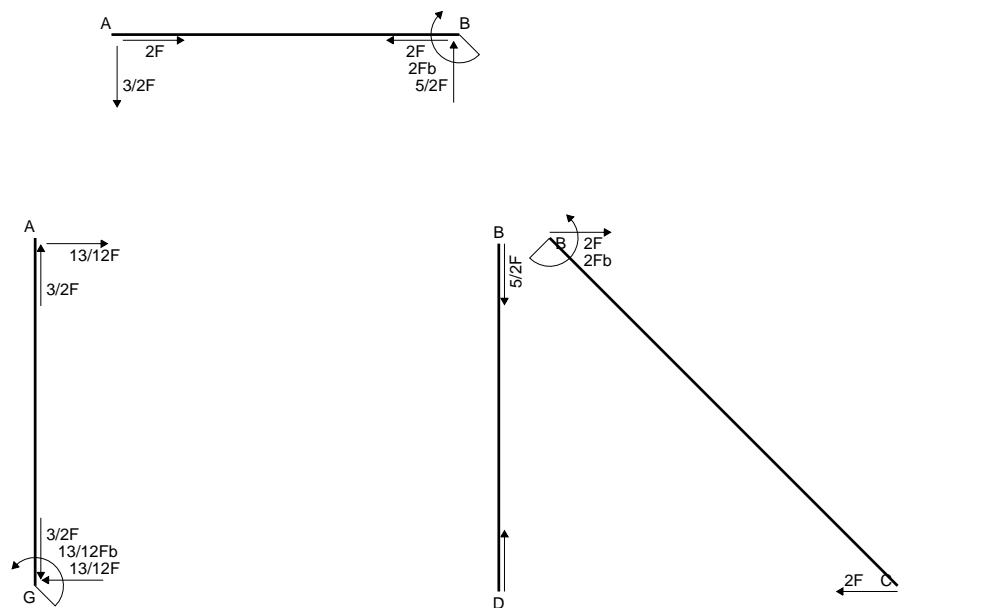

← ⊕ → F

↑ ⊕ ↓ F

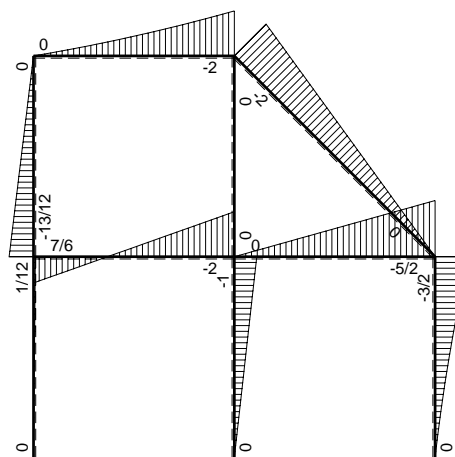

⊕ ⊖ Fb

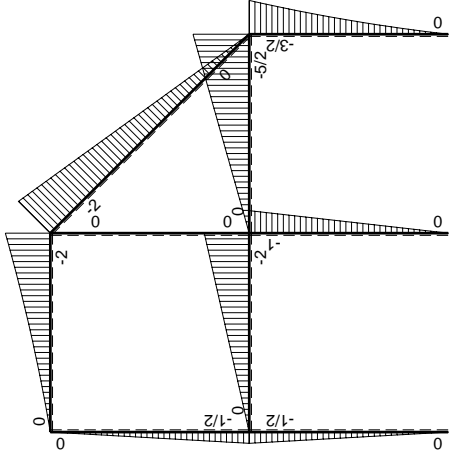
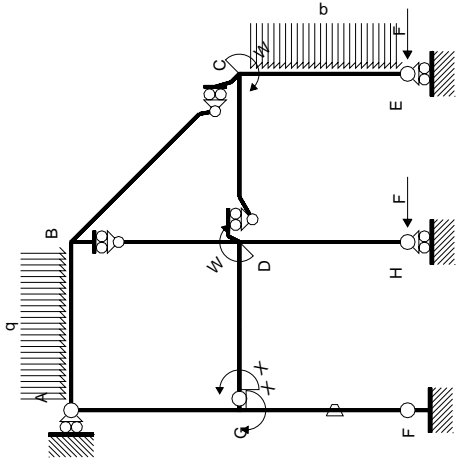

Schema di calcolo iperstatico

M_0 flessione da carichi assegnati

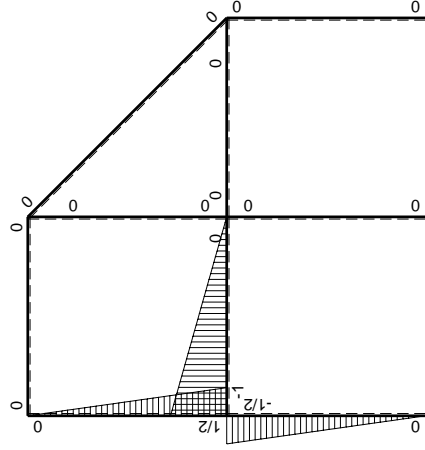

M_x flessione da iperstatica $X=1$

Quadro contributi PLV per iperstatica $X=W_{GD}$

→	$M_x(x)$	$M_o(x)$	θ	$M_x M_o$	$M_x \theta$	$M_x M_x$	$\int M_x(M_o/EJ+\theta)dx$	$\int X M_x M_x/EJ dx$	
AB b	0	$-3/2Fx-1/2qx^2$	0	0	0	0	0+0	0	
BA b	0	$2Fb-5/2Fx+1/2qx^2$	0	0	0	0			
BC $\sqrt{2}b$	0	$-2Fb+\sqrt{2}Fx$	0	0	0	0	0	0	
BD b	0	0	0	0	0	0	0+0	0	
DB b	0	0	0	0	0	0			
DC b	0	$-5/2Fx$	0	0	0	0	0+0	0	
CD b	0	$5/2Fb-5/2Fx$	0	0	0	0			
CE b	0	$-3/2Fb+2Fx-1/2qx^2$	0	0	0	0	0+0	0	
EC b	0	$Fx+1/2qx^2$	0	0	0	0			
FG b	$-1/2x/b$	$-1/2Fx$	$-Fb/EJ$	$1/4Fx^2/b$	$1/2Fx/EJ$	$1/4x^2/b^2$	$(1/12+1/4)Fb^2/EJ$	$1/12Xb/EJ$	
GF b	$1/2-1/2x/b$	$1/2Fb-1/2Fx$	Fb/EJ	$1/4Fb-1/2Fx+1/4Fx^2/b$	$1/2Fb/EJ-1/2Fx/EJ$	$1/4-1/2x/b+1/4x^2/b^2$			
GD b	$-1+x/b$	$-2Fx$	0	$2Fx-2Fx^2/b$	0	$1-2x/b+x^2/b^2$	$(1/3+0)Fb^2/EJ$	$1/3Xb/EJ$	
DG b	x/b	$2Fb-2Fx$	0	$2Fx-2Fx^2/b$	0	x^2/b^2			
DH b	0	$-Fb+Fx$	0	0	0	0	0+0	0	
HD b	0	Fx	0	0	0	0			
GA b	$1/2-1/2x/b$	$-1/2Fb+1/2Fx$	0	$-1/4Fb+1/2Fx-1/4Fx^2/b$	0	$1/4-1/2x/b+1/4x^2/b^2$	$(-1/12+0)Fb^2/EJ$	$1/12Xb/EJ$	
AG b	$-1/2x/b$	$1/2Fx$	0	$-1/4Fx^2/b$	0	$1/4x^2/b^2$			
	totali							$7/12Fb^2/EJ$	$1/2Xb/EJ$
	iperstatica $X=W_{GD}$							$-7/6Fb$	

Sviluppi di calcolo iperstatica

$$L_{FG}^{xx} = \int_0^b (1/4 x^2/b^2) 1/EJ dx = [1/12 x^3/b^2]_0^b 1/EJ$$

$$= (1/12 b) 1/EJ = 1/12 b/EJ$$

$$L_{GF}^{xx} = \int_0^b (1/4 - 1/2 x/b + 1/4 x^2/b^2) 1/EJ dx = [1/4 x - 1/4 x^2/b + 1/12 x^3/b^2]_0^b 1/EJ$$

$$= (1/4 b - 1/4 b + 1/12 b) 1/EJ = 1/12 b/EJ$$

$$L_{GD}^{xx} = \int_0^b (1 - 2 x/b + x^2/b^2) 1/EJ dx = [x - x^2/b + 1/3 x^3/b^2]_0^b 1/EJ$$

$$= (b - b + 1/3 b) 1/EJ = 1/3 b/EJ$$

$$L_{DG}^{xx} = \int_0^b (x^2/b^2) 1/EJ dx = [1/3 x^3/b^2]_0^b 1/EJ$$

$$= (1/3 b) 1/EJ = 1/3 b/EJ$$

$$L_{GA}^{xx} = \int_0^b (1/4 - 1/2 x/b + 1/4 x^2/b^2) 1/EJ dx = [1/4 x - 1/4 x^2/b + 1/12 x^3/b^2]_0^b 1/EJ$$

$$= (1/4 b - 1/4 b + 1/12 b) 1/EJ = 1/12 b/EJ$$

$$L_{AG}^{xx} = \int_0^b (1/4 x^2/b^2) 1/EJ dx = [1/12 x^3/b^2]_0^b 1/EJ$$

$$= (1/12 b) 1/EJ = 1/12 b/EJ$$

$$L_{FG}^{xo} = \int_0^b (1/4 x^2/b^2) Fb 1/EJ dx + \int_0^b (1/2 x/b) \theta dx = [1/12 x^3/b^2]_0^b Fb 1/EJ + [1/4 x^2/b]_0^b \theta$$

$$= (1/12 b) Fb 1/EJ + (1/4 b) \theta = 1/3 Fb^2/EJ$$

$$L_{GF}^{xo} = \int_0^b (1/4 - 1/2 x/b + 1/4 x^2/b^2) Fb 1/EJ dx + \int_0^b (-1/2 + 1/2 x/b) \theta dx$$

$$= [1/4 x - 1/4 x^2/b + 1/12 x^3/b^2]_0^b Fb 1/EJ + [-1/2 x + 1/4 x^2/b]_0^b \theta$$

$$= (1/4 b - 1/4 b + 1/12 b) Fb 1/EJ + (-1/2 b + 1/4 b) \theta = 1/3 Fb^2/EJ$$

$$L_{GD}^{xo} = \int_0^b (2 x/b - 2 x^2/b^2) Fb 1/EJ dx = [x^2/b - 2/3 x^3/b^2]_0^b Fb 1/EJ$$

$$= (b - 2/3 b) Fb 1/EJ = 1/3 Fb^2/EJ$$

$$L_{DG}^{xo} = \int_0^b (2 x/b - 2 x^2/b^2) Fb 1/EJ dx = [x^2/b - 2/3 x^3/b^2]_0^b Fb 1/EJ$$

$$= (b - 2/3 b) Fb 1/EJ = 1/3 Fb^2/EJ$$

$$L_{GA}^{xo} = \int_0^b (-1/4 + 1/2 x/b - 1/4 x^2/b^2) Fb 1/EJ dx = [-1/4 x + 1/4 x^2/b - 1/12 x^3/b^2]_0^b Fb 1/EJ$$

$$= (-1/4 b + 1/4 b - 1/12 b) Fb 1/EJ = -1/12 Fb^2/EJ$$

$$L_{AG}^{xo} = \int_0^b (-1/4 x^2/b^2) Fb 1/EJ dx = [-1/12 x^3/b^2]_0^b Fb 1/EJ$$

$$= (-1/12 b) Fb 1/EJ = -1/12 Fb^2/EJ$$

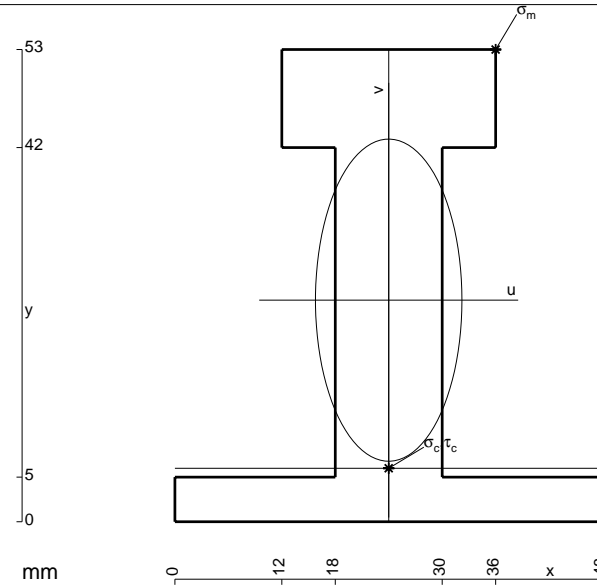

$$A = 948. \text{ mm}^2$$

$$J_u = 309947. \text{ mm}^4$$

$$J_v = 64080. \text{ mm}^4$$

$$y_g = 24.87 \text{ mm}$$

$$T_y = -3775. \text{ N}$$

$$M_x = -2642500. \text{ Nmm}$$

$$x_m = 36. \text{ mm}$$

$$y_m = 53. \text{ mm}$$

$$u_m = 12. \text{ mm}$$

$$v_m = 28.13 \text{ mm}$$

$$\sigma_m = -Mv/J_u = 239.9 \text{ N/mm}^2$$

$$x_c = 24. \text{ mm}$$

$$y_c = 6. \text{ mm}$$

$$v_c = -18.87 \text{ mm}$$

$$\sigma_c = -Mv/J_u = -160.9 \text{ N/mm}^2$$

$$\tau_c = 5.684 \text{ N/mm}^2$$

$$\sigma_q = \sqrt{\sigma^2 + 3\tau^2} = 161.2 \text{ N/mm}^2$$

$$S = 5601. \text{ mm}^3$$

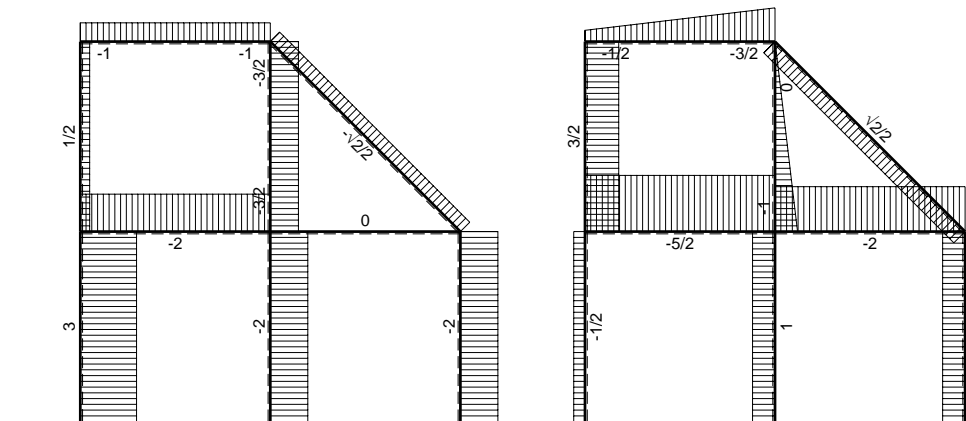
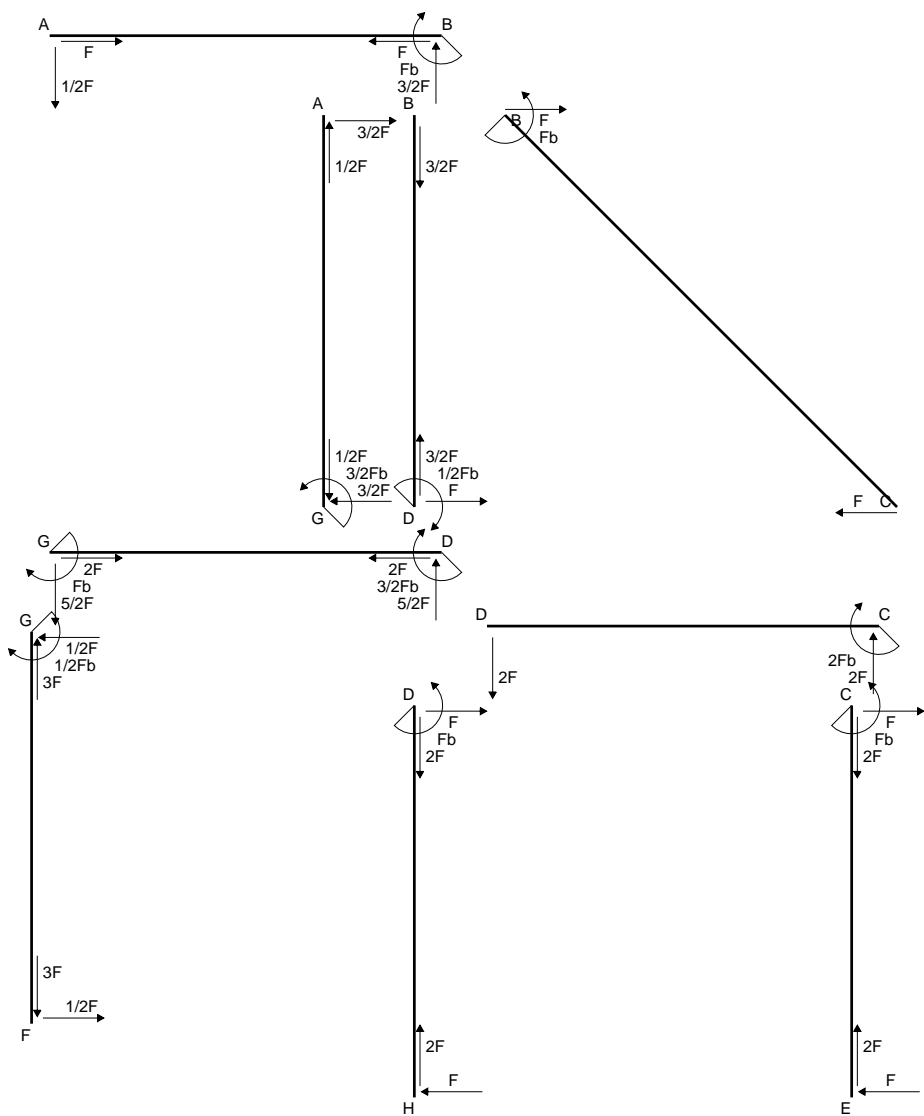

← ⊕ → F

↑ ⊕ ↓ F

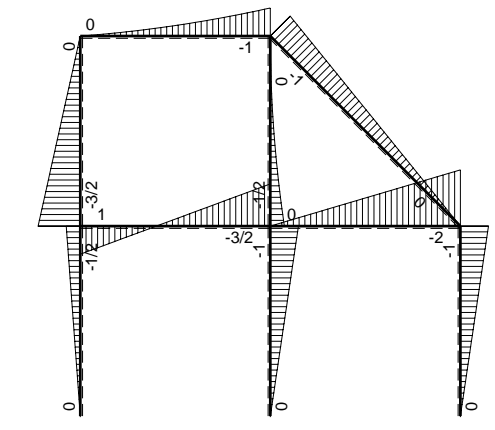

⊕ ⊖ Fb

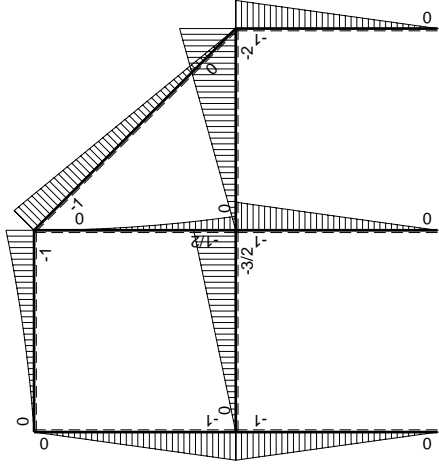
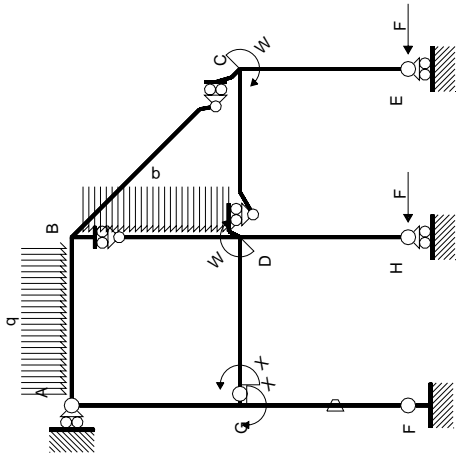

Schema di calcolo iperstatico

M_0 flessione da carichi assegnati

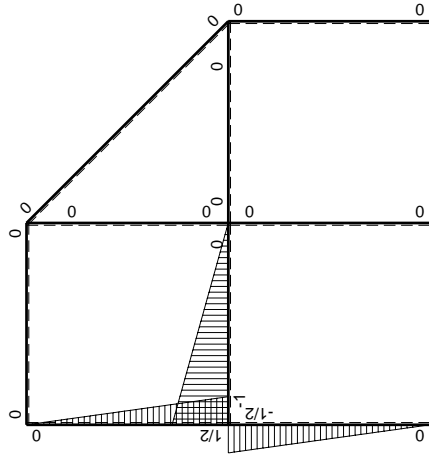

M_x flessione da iperstatica $X=1$

Quadro contributi PLV per iperstatica $X=W_{GD}$

→	$M_x(x)$	$M_o(x)$	θ	$M_x M_o$	$M_x \theta$	$M_x M_x$	$\int M_x(M_o/EJ+\theta)dx$	$\int X M_x M_x/EJdx$
AB b	0	$-1/2Fx-1/2qx^2$	0	0	0	0	0+0	0
BA b	0	$Fb-3/2Fx+1/2qx^2$	0	0	0	0		
BC $\sqrt{2}b$	0	$-Fb+\sqrt{2}/2Fx$	0	0	0	0	0	0
BD b	0	$-1/2qx^2$	0	0	0	0	0+0	0
DB b	0	$1/2Fb-Fx+1/2qx^2$	0	0	0	0		
DC b	0	$-2Fx$	0	0	0	0	0+0	0
CD b	0	$2Fb-2Fx$	0	0	0	0		
CE b	0	$-Fb+Fx$	0	0	0	0	0+0	0
EC b	0	Fx	0	0	0	0		
FG b	$-1/2x/b$	$-Fx$	$-Fb/EJ$	$1/2Fx^2/b$	$1/2Fx/EJ$	$1/4x^2/b^2$	$(1/6+1/4)Fb^2/EJ$	$1/12Xb/EJ$
GF b	$1/2-1/2x/b$	$Fb-Fx$	Fb/EJ	$1/2Fb-Fx+1/2Fx^2/b$	$1/2Fb/EJ-1/2Fx/EJ$	$1/4-1/2x/b+1/4x^2/b^2$		
GD b	$-1+x/b$	$-3/2Fx$	0	$3/2Fx-3/2Fx^2/b$	0	$1-2x/b+x^2/b^2$	$(1/4+0)Fb^2/EJ$	$1/3Xb/EJ$
DG b	x/b	$3/2Fb-3/2Fx$	0	$3/2Fx-3/2Fx^2/b$	0	x^2/b^2		
DH b	0	$-Fb+Fx$	0	0	0	0	0+0	0
HD b	0	Fx	0	0	0	0		
GA b	$1/2-1/2x/b$	$-Fb+Fx$	0	$-1/2Fb+Fx-1/2Fx^2/b$	0	$1/4-1/2x/b+1/4x^2/b^2$	$(-1/6+0)Fb^2/EJ$	$1/12Xb/EJ$
AG b	$-1/2x/b$	Fx	0	$-1/2Fx^2/b$	0	$1/4x^2/b^2$		
	totali						$1/2Fb^2/EJ$	$1/2Xb/EJ$
	iperstatica $X=W_{GD}$						$-Fb$	

Sviluppi di calcolo iperstatica

$$L_{FG}^{xx} = \int_0^b (1/4 x^2/b^2) 1/EJ dx = [1/12 x^3/b^2]_0^b 1/EJ$$

$$= (1/12 b) 1/EJ = 1/12 b/EJ$$

$$L_{GF}^{xx} = \int_0^b (1/4 - 1/2 x/b + 1/4 x^2/b^2) 1/EJ dx = [1/4 x - 1/4 x^2/b + 1/12 x^3/b^2]_0^b 1/EJ$$

$$= (1/4 b - 1/4 b + 1/12 b) 1/EJ = 1/12 b/EJ$$

$$L_{GD}^{xx} = \int_0^b (1 - 2 x/b + x^2/b^2) 1/EJ dx = [x - x^2/b + 1/3 x^3/b^2]_0^b 1/EJ$$

$$= (b - b + 1/3 b) 1/EJ = 1/3 b/EJ$$

$$L_{DG}^{xx} = \int_0^b (x^2/b^2) 1/EJ dx = [1/3 x^3/b^2]_0^b 1/EJ$$

$$= (1/3 b) 1/EJ = 1/3 b/EJ$$

$$L_{GA}^{xx} = \int_0^b (1/4 - 1/2 x/b + 1/4 x^2/b^2) 1/EJ dx = [1/4 x - 1/4 x^2/b + 1/12 x^3/b^2]_0^b 1/EJ$$

$$= (1/4 b - 1/4 b + 1/12 b) 1/EJ = 1/12 b/EJ$$

$$L_{AG}^{xx} = \int_0^b (1/4 x^2/b^2) 1/EJ dx = [1/12 x^3/b^2]_0^b 1/EJ$$

$$= (1/12 b) 1/EJ = 1/12 b/EJ$$

$$L_{FG}^{x\theta} = \int_0^b (1/2 x^2/b^2) Fb 1/EJ dx + \int_0^b (1/2 x/b) \theta dx = [1/6 x^3/b^2]_0^b Fb 1/EJ + [1/4 x^2/b]_0^b \theta$$

$$= (1/6 b) Fb 1/EJ + (1/4 b) \theta = 5/12 Fb^2/EJ$$

$$L_{GF}^{x\theta} = \int_0^b (1/2 - x/b + 1/2 x^2/b^2) Fb 1/EJ dx + \int_0^b (-1/2 + 1/2 x/b) \theta dx$$

$$= [1/2 x - 1/2 x^2/b + 1/6 x^3/b^2]_0^b Fb 1/EJ + [-1/2 x + 1/4 x^2/b]_0^b \theta$$

$$= (1/2 b - 1/2 b + 1/6 b) Fb 1/EJ + (-1/2 b + 1/4 b) \theta = 5/12 Fb^2/EJ$$

$$L_{GD}^{x\theta} = \int_0^b (3/2 x/b - 3/2 x^2/b^2) Fb 1/EJ dx = [3/4 x^2/b - 1/2 x^3/b^2]_0^b Fb 1/EJ$$

$$= (3/4 b - 1/2 b) Fb 1/EJ = 1/4 Fb^2/EJ$$

$$L_{DG}^{x\theta} = \int_0^b (3/2 x/b - 3/2 x^2/b^2) Fb 1/EJ dx = [3/4 x^2/b - 1/2 x^3/b^2]_0^b Fb 1/EJ$$

$$= (3/4 b - 1/2 b) Fb 1/EJ = 1/4 Fb^2/EJ$$

$$L_{GA}^{x\theta} = \int_0^b (-1/2 + x/b - 1/2 x^2/b^2) Fb 1/EJ dx = [-1/2 x + 1/2 x^2/b - 1/6 x^3/b^2]_0^b Fb 1/EJ$$

$$= (-1/2 b + 1/2 b - 1/6 b) Fb 1/EJ = -1/6 Fb^2/EJ$$

$$L_{AG}^{x\theta} = \int_0^b (-1/2 x^2/b^2) Fb 1/EJ dx = [-1/6 x^3/b^2]_0^b Fb 1/EJ$$

$$= (-1/6 b) Fb 1/EJ = -1/6 Fb^2/EJ$$

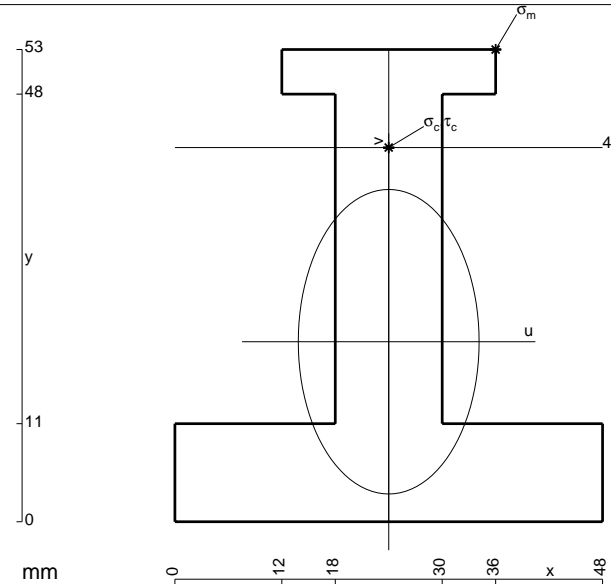

$$A = 1092. \text{ mm}^2$$

$$J_u = 318895. \text{ mm}^4$$

$$J_v = 112464. \text{ mm}^4$$

$$y_g = 20.2 \text{ mm}$$

$$T_y = -2580. \text{ N}$$

$$M_x = -1935000. \text{ Nmm}$$

$$x_m = 36. \text{ mm}$$

$$y_m = 53. \text{ mm}$$

$$u_m = 12. \text{ mm}$$

$$v_m = 32.8 \text{ mm}$$

$$\sigma_m = -Mv/J_u = 199. \text{ N/mm}^2$$

$$x_c = 24. \text{ mm}$$

$$y_c = 42. \text{ mm}$$

$$v_c = 21.8 \text{ mm}$$

$$\sigma_c = -Mv/J_u = 132.3 \text{ N/mm}^2$$

$$\tau_c = 3.655 \text{ N/mm}^2$$

$$\sigma_\varphi = \sqrt{\sigma_c^2 + 3\tau_c^2} = 132.4 \text{ N/mm}^2$$

$$S = 5421. \text{ mm}^3$$

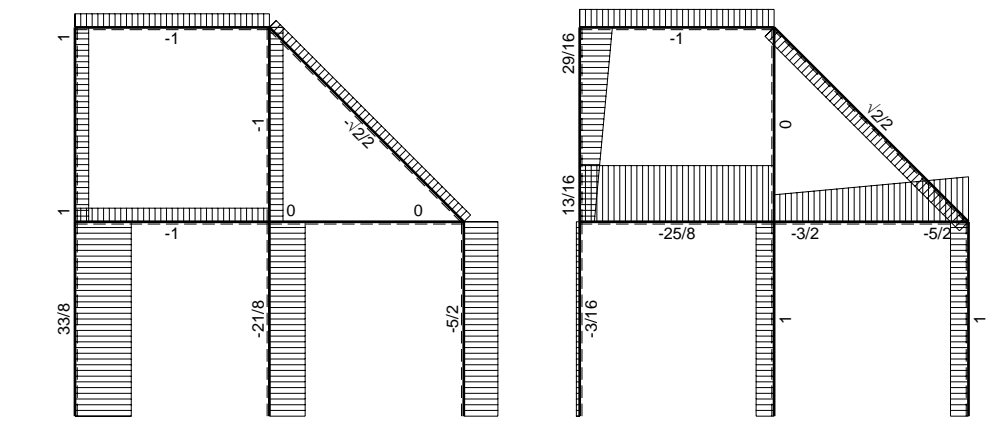
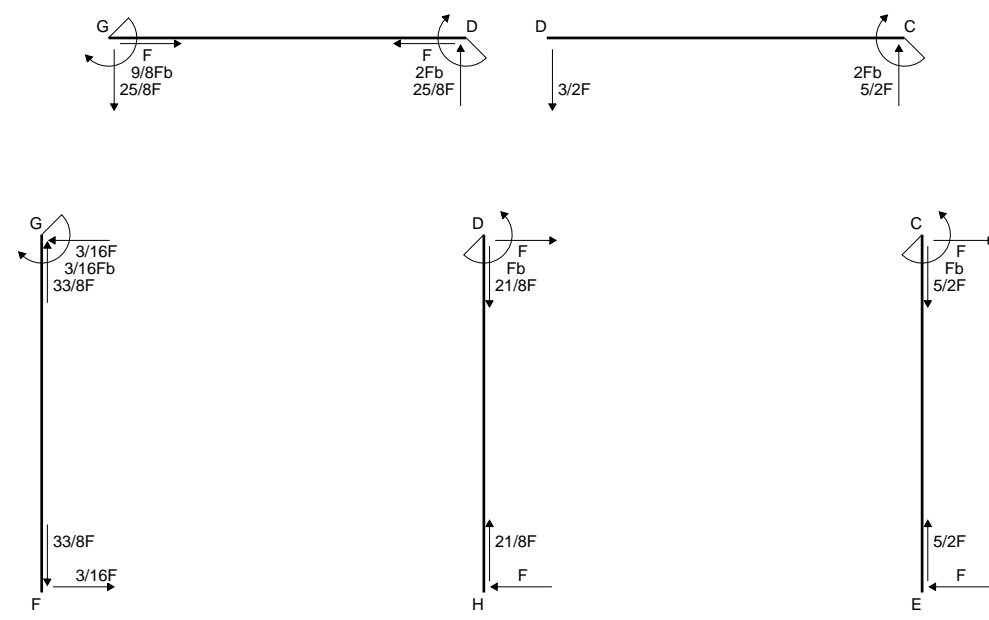
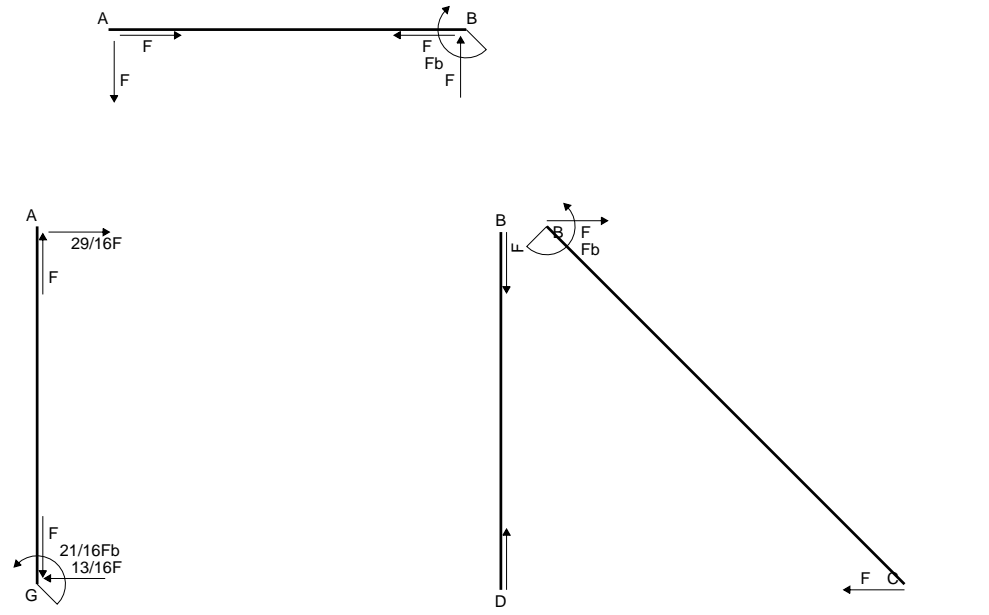

← ⊕ → F

↑ ⊕ ↓ Fb

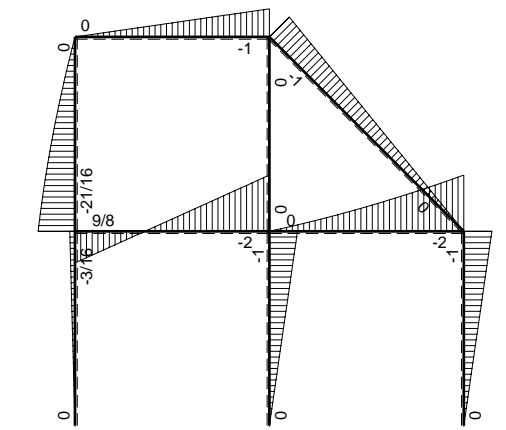

⊕ ⊖ Fb

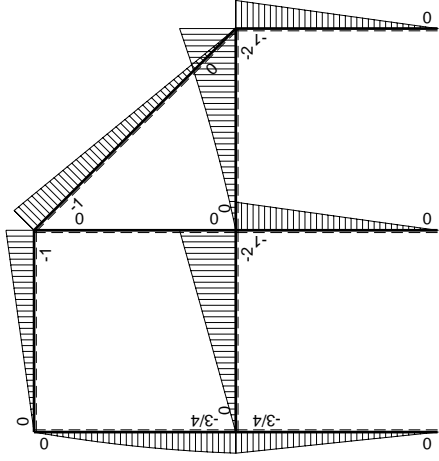
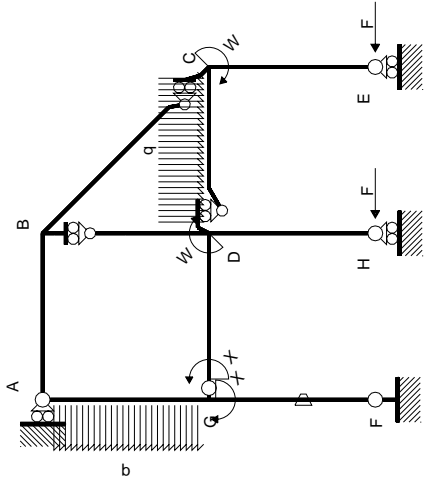

Schema di calcolo iperstatico

M_0 flessione da carichi assegnati

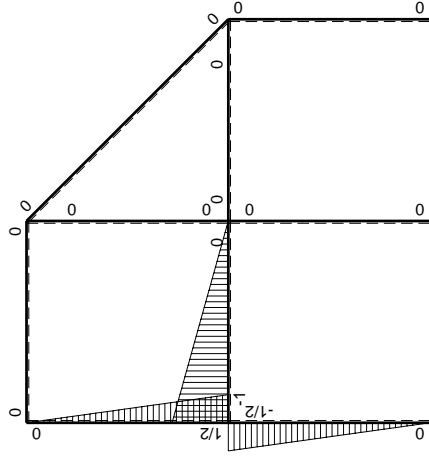

M_x flessione da iperstatica $X=1$

Quadro contributi PLV per iperstatica $X=W_{GD}$

→	$M_x(x)$	$M_o(x)$	θ	$M_x M_o$	$M_x \theta$	$M_x M_x$	$\int M_x(M_o/EJ+\theta)dx$	$\int X M_x M_x/EJ dx$
AB b	0	-Fx	0	0	0	0	0+0	0
BA b	0	Fb-Fx	0	0	0	0	0	0
BC $\sqrt{2}b$	0	-Fb+ $\sqrt{2}/2Fx$	0	0	0	0	0	0
BD b	0	0	0	0	0	0	0+0	0
DB b	0	0	0	0	0	0	0	0
DC b	0	-3/2Fx-1/2qx ²	0	0	0	0	0+0	0
CD b	0	2Fb-5/2Fx+1/2qx ²	0	0	0	0	0	0
CE b	0	-Fb+Fx	0	0	0	0	0+0	0
EC b	0	Fx	0	0	0	0	0	0
FG b	-1/2x/b	-3/4Fx	-Fb/EJ	3/8Fx ² /b	1/2Fx/EJ	1/4x ² /b ²	(1/8+1/4)Fb ² /EJ	1/12Xb/EJ
GF b	1/2-1/2x/b	3/4Fb-3/4Fx	Fb/EJ	3/8Fb-3/4Fx+3/8Fx ² /b	1/2Fb/EJ-1/2Fx/EJ	1/4-1/2x/b+1/4x ² /b ²		
GD b	-1+x/b	-2Fx	0	2Fx-2Fx ² /b	0	1-2x/b+x ² /b ²	(1/3+0)Fb ² /EJ	1/3Xb/EJ
DG b	x/b	2Fb-2Fx	0	2Fx-2Fx ² /b	0	x ² /b ²		
DH b	0	-Fb+Fx	0	0	0	0	0+0	0
HD b	0	Fx	0	0	0	0	0	0
GA b	1/2-1/2x/b	-3/4Fb+1/4Fx+1/2qx ²	0	-3/8Fb+1/2Fx+1/8Fx ² /b-1/4qx ³ /b	0	1/4-1/2x/b+1/4x ² /b ²	(-7/48+0)Fb ² /EJ	1/12Xb/EJ
AG b	-1/2x/b	5/4Fx-1/2qx ²	0	-5/8Fx ² /b+1/4qx ³ /b	0	1/4x ² /b ²		
	totali						9/16Fb ² /EJ	1/2Xb/EJ
	iperstatica $X=W_{GD}$						-9/8Fb	

Sviluppi di calcolo iperstatica

$$L_{FG}^{xx} = \int_0^b (1/4 x^2/b^2) 1/EJ dx = [1/12 x^3/b^2]_0^b 1/EJ$$

$$= (1/12 b) 1/EJ = 1/12 b/EJ$$

$$L_{GF}^{xx} = \int_0^b (1/4 - 1/2 x/b + 1/4 x^2/b^2) 1/EJ dx = [1/4 x - 1/4 x^2/b + 1/12 x^3/b^2]_0^b 1/EJ$$

$$= (1/4 b - 1/4 b + 1/12 b) 1/EJ = 1/12 b/EJ$$

$$L_{GD}^{xx} = \int_0^b (1 - 2 x/b + x^2/b^2) 1/EJ dx = [x - x^2/b + 1/3 x^3/b^2]_0^b 1/EJ$$

$$= (b - b + 1/3 b) 1/EJ = 1/3 b/EJ$$

$$L_{DG}^{xx} = \int_0^b (x^2/b^2) 1/EJ dx = [1/3 x^3/b^2]_0^b 1/EJ$$

$$= (1/3 b) 1/EJ = 1/3 b/EJ$$

$$L_{GA}^{xx} = \int_0^b (1/4 - 1/2 x/b + 1/4 x^2/b^2) 1/EJ dx = [1/4 x - 1/4 x^2/b + 1/12 x^3/b^2]_0^b 1/EJ$$

$$= (1/4 b - 1/4 b + 1/12 b) 1/EJ = 1/12 b/EJ$$

$$L_{AG}^{xx} = \int_0^b (1/4 x^2/b^2) 1/EJ dx = [1/12 x^3/b^2]_0^b 1/EJ$$

$$= (1/12 b) 1/EJ = 1/12 b/EJ$$

$$L_{FG}^{xo} = \int_0^b (3/8 x^2/b^2) Fb 1/EJ dx + \int_0^b (1/2 x/b) \theta dx = [1/8 x^3/b^2]_0^b Fb 1/EJ + [1/4 x^2/b]_0^b \theta$$

$$= (1/8 b) Fb 1/EJ + (1/4 b) \theta = 3/8 Fb^2/EJ$$

$$L_{GF}^{xo} = \int_0^b (3/8 - 3/4 x/b + 3/8 x^2/b^2) Fb 1/EJ dx + \int_0^b (-1/2 + 1/2 x/b) \theta dx$$

$$= [3/8 x - 3/8 x^2/b + 1/8 x^3/b^2]_0^b Fb 1/EJ + [-1/2 x + 1/4 x^2/b]_0^b \theta$$

$$= (3/8 b - 3/8 b + 1/8 b) Fb 1/EJ + (-1/2 b + 1/4 b) \theta = 3/8 Fb^2/EJ$$

$$L_{GD}^{xo} = \int_0^b (2 x/b - 2 x^2/b^2) Fb 1/EJ dx = [x^2/b - 2/3 x^3/b^2]_0^b Fb 1/EJ$$

$$= (b - 2/3 b) Fb 1/EJ = 1/3 Fb^2/EJ$$

$$L_{DG}^{xo} = \int_0^b (2 x/b - 2 x^2/b^2) Fb 1/EJ dx = [x^2/b - 2/3 x^3/b^2]_0^b Fb 1/EJ$$

$$= (b - 2/3 b) Fb 1/EJ = 1/3 Fb^2/EJ$$

$$L_{GA}^{xo} = \int_0^b (-3/8 + 1/2 x/b + 1/8 x^2/b^2 - 1/4 x^3/b^3) Fb 1/EJ dx$$

$$= [-3/8 x + 1/4 x^2/b + 1/24 x^3/b^2 - 1/16 x^4/b^3]_0^b Fb 1/EJ$$

$$= (-3/8 b + 1/4 b + 1/24 b - 1/16 b) Fb 1/EJ = -7/48 Fb^2/EJ$$

$$L_{AG}^{xo} = \int_0^b (-5/8 x^2/b^2 + 1/4 x^3/b^3) Fb 1/EJ dx = [-5/24 x^3/b^2 + 1/16 x^4/b^3]_0^b Fb 1/EJ$$

$$= (-5/24 b + 1/16 b) Fb 1/EJ = -7/48 Fb^2/EJ$$

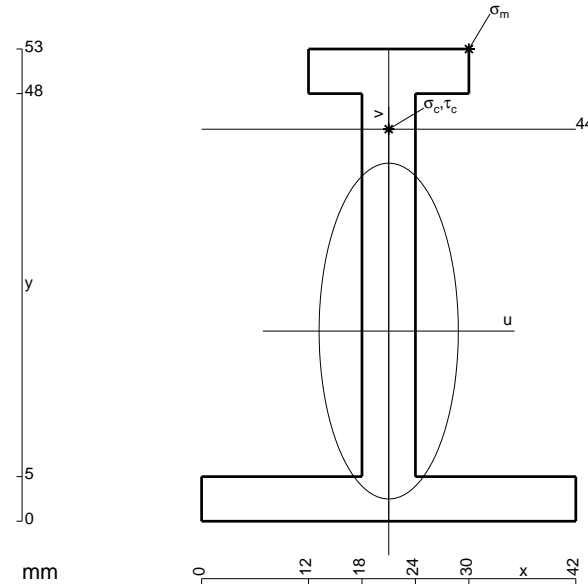

- A = 558. mm²
- J_u = 198314. mm⁴
- J_v = 34074. mm⁴
- y_g = 21.34 mm
- T_y = -2050. N
- M_x = -1312000. Nmm
- x_m = 30. mm
- y_m = 53. mm
- u_m = 9. mm
- v_m = 31.66 mm
- σ_m = -Mv/J_u = 209.5 N/mm²
- x_c = 21. mm
- y_c = 44. mm
- v_c = 22.66 mm
- σ_c = -Mv/J_u = 149.9 N/mm²
- τ_c = 5.541 N/mm²
- σ_o = √σ²+3τ² = 150.2 N/mm²
- S = 3216. mm³

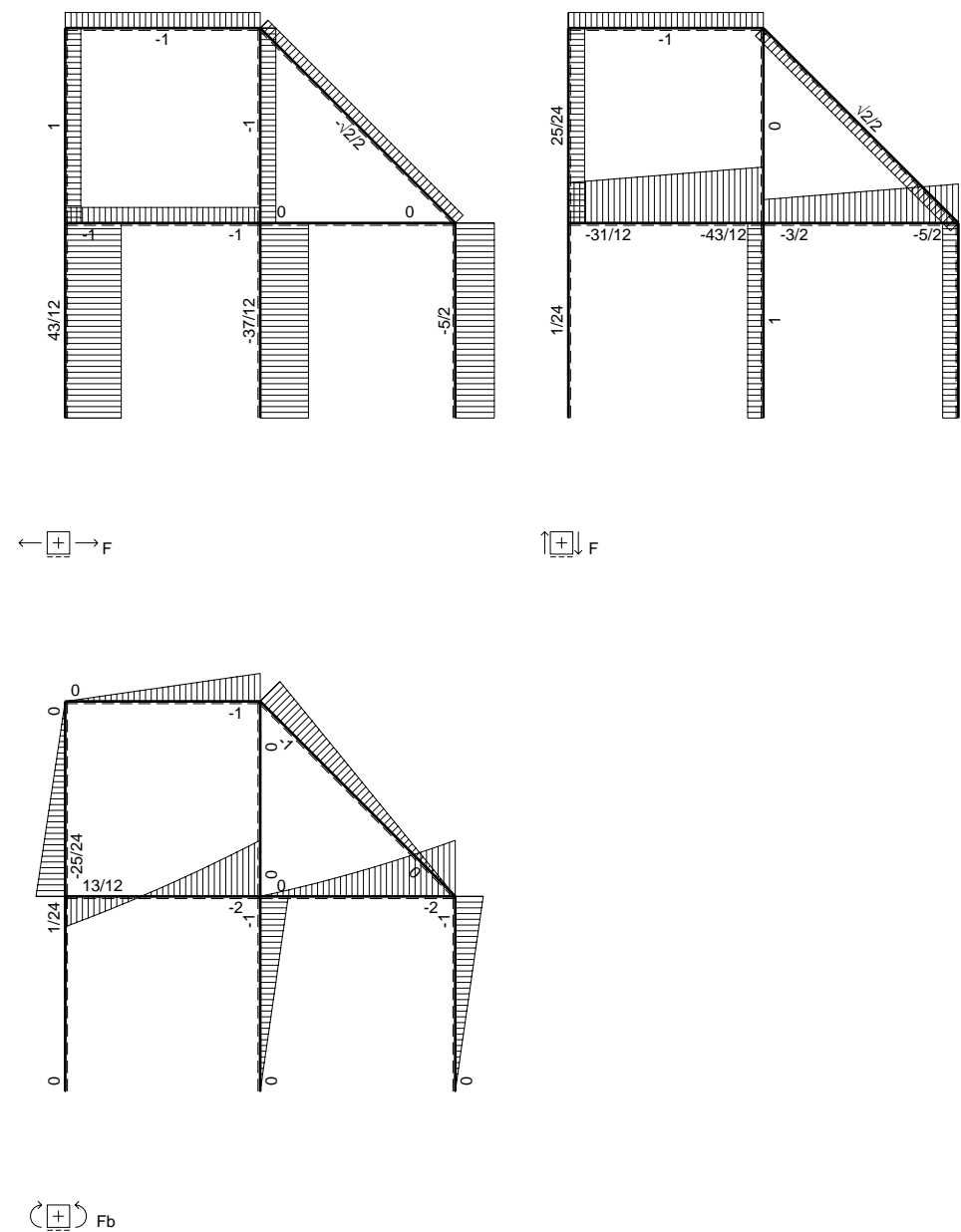
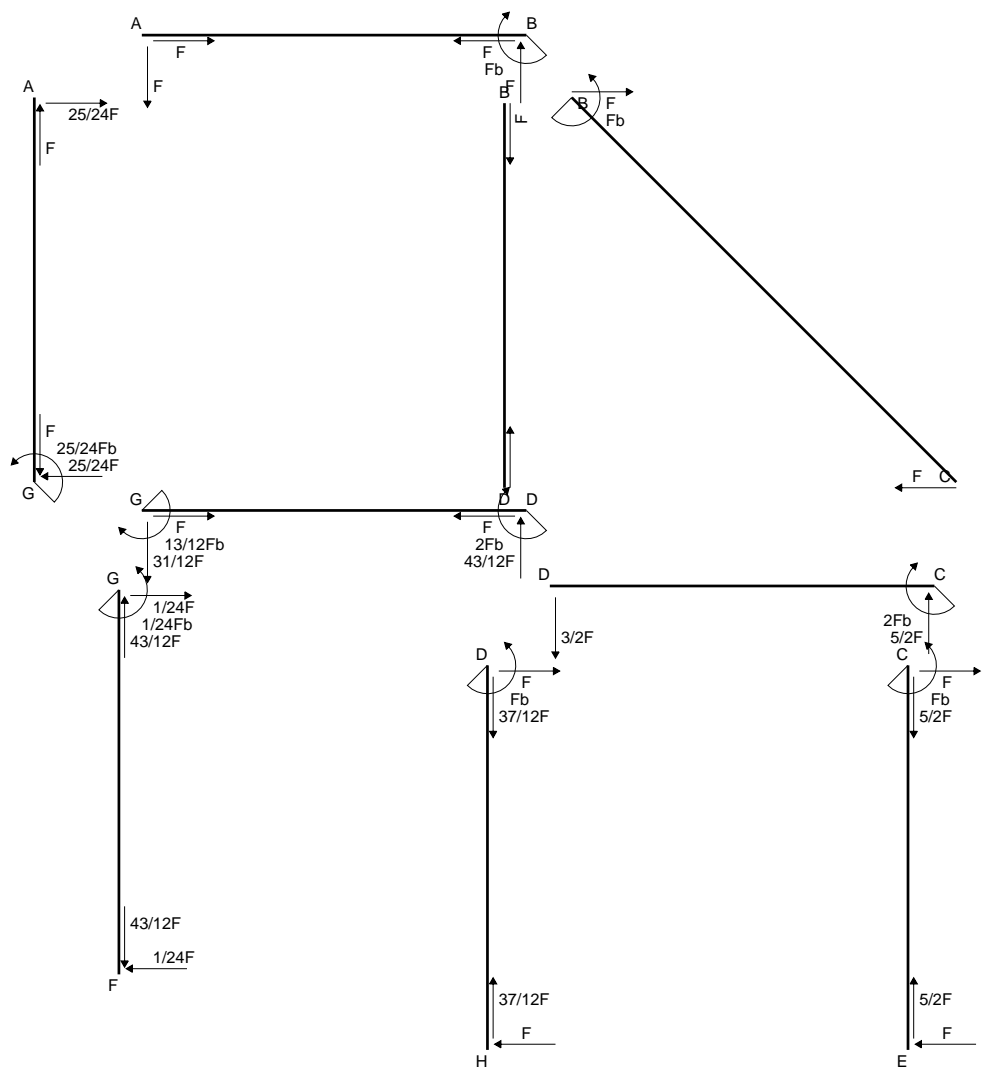

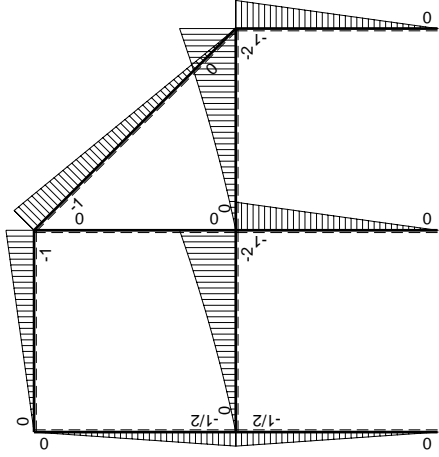
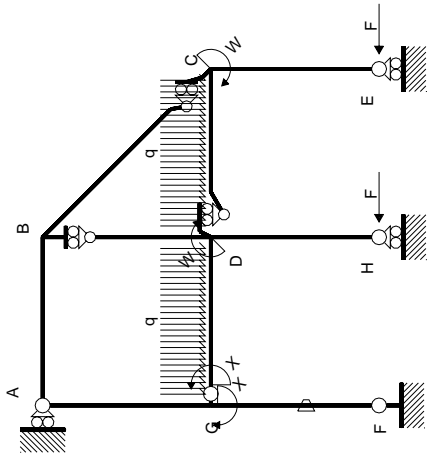

Schema di calcolo iperstatico

M_0 flessione da carichi assegnati

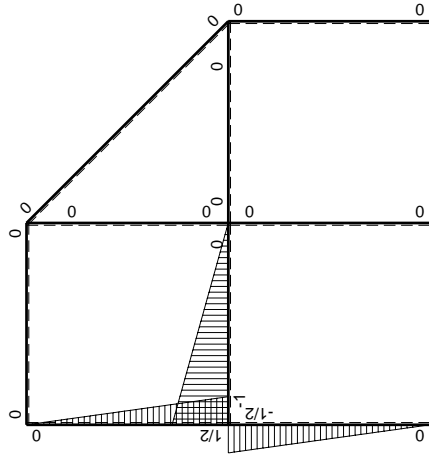

M_x flessione da iperstatica $X=1$

Quadro contributi PLV per iperstatica $X=W_{GD}$

→	$M_x(x)$	$M_o(x)$	θ	$M_x M_o$	$M_x \theta$	$M_x M_x$	$\int M_x(M_o/EJ+\theta)dx$	$\int X M_x M_x/EJdx$
AB b	0	-Fx	0	0	0	0	0+0	0
BA b	0	Fb-Fx	0	0	0	0		
BC $\sqrt{2}b$	0	-Fb+ $\sqrt{2}/2Fx$	0	0	0	0	0	0
BD b	0	0	0	0	0	0	0+0	0
DB b	0	0	0	0	0	0		
DC b	0	-3/2Fx-1/2qx ²	0	0	0	0	0+0	0
CD b	0	2Fb-5/2Fx+1/2qx ²	0	0	0	0		
CE b	0	-Fb+Fx	0	0	0	0	0+0	0
EC b	0	Fx	0	0	0	0		
FG b	-1/2x/b	-1/2Fx	-Fb/EJ	1/4Fx ² /b	1/2Fx/EJ	1/4x ² /b ²	(1/12+1/4)Fb ² /EJ	1/12Xb/EJ
GF b	1/2-1/2x/b	1/2Fb-1/2Fx	Fb/EJ	1/4Fb-1/2Fx+1/4Fx ² /b	1/2Fb/EJ-1/2Fx/EJ	1/4-1/2x/b+1/4x ² /b ²		
GD b	-1+x/b	-3/2Fx-1/2qx ²	0	3/2Fx-Fx ² /b-1/2qx ³ /b	0	1-2x/b+x ² /b ²	(7/24+0)Fb ² /EJ	1/3Xb/EJ
DG b	x/b	2Fb-5/2Fx+1/2qx ²	0	2Fx-5/2Fx ² /b+1/2qx ³ /b	0	x ² /b ²		
DH b	0	-Fb+Fx	0	0	0	0	0+0	0
HD b	0	Fx	0	0	0	0		
GA b	1/2-1/2x/b	-1/2Fb+1/2Fx	0	-1/4Fb+1/2Fx-1/4Fx ² /b	0	1/4-1/2x/b+1/4x ² /b ²	(-1/12+0)Fb ² /EJ	1/12Xb/EJ
AG b	-1/2x/b	1/2Fx	0	-1/4Fx ² /b	0	1/4x ² /b ²		
	totali						13/24Fb ² /EJ	1/2Xb/EJ
	iperstatica $X=W_{GD}$						-13/12Fb	

Sviluppi di calcolo iperstatica

$$L_{FG}^{xx} = \int_0^b (1/4 x^2/b^2) 1/EJ dx = [1/12 x^3/b^2]_0^b 1/EJ$$

$$= (1/12 b) 1/EJ = 1/12 b/EJ$$

$$L_{GF}^{xx} = \int_0^b (1/4 - 1/2 x/b + 1/4 x^2/b^2) 1/EJ dx = [1/4 x - 1/4 x^2/b + 1/12 x^3/b^2]_0^b 1/EJ$$

$$= (1/4 b - 1/4 b + 1/12 b) 1/EJ = 1/12 b/EJ$$

$$L_{GD}^{xx} = \int_0^b (1 - 2 x/b + x^2/b^2) 1/EJ dx = [x - x^2/b + 1/3 x^3/b^2]_0^b 1/EJ$$

$$= (b - b + 1/3 b) 1/EJ = 1/3 b/EJ$$

$$L_{DG}^{xx} = \int_0^b (x^2/b^2) 1/EJ dx = [1/3 x^3/b^2]_0^b 1/EJ$$

$$= (1/3 b) 1/EJ = 1/3 b/EJ$$

$$L_{GA}^{xx} = \int_0^b (1/4 - 1/2 x/b + 1/4 x^2/b^2) 1/EJ dx = [1/4 x - 1/4 x^2/b + 1/12 x^3/b^2]_0^b 1/EJ$$

$$= (1/4 b - 1/4 b + 1/12 b) 1/EJ = 1/12 b/EJ$$

$$L_{AG}^{xx} = \int_0^b (1/4 x^2/b^2) 1/EJ dx = [1/12 x^3/b^2]_0^b 1/EJ$$

$$= (1/12 b) 1/EJ = 1/12 b/EJ$$

$$L_{FG}^{xo} = \int_0^b (1/4 x^2/b^2) Fb 1/EJ dx + \int_0^b (1/2 x/b) \theta dx = [1/12 x^3/b^2]_0^b Fb 1/EJ + [1/4 x^2/b]_0^b \theta$$

$$= (1/12 b) Fb 1/EJ + (1/4 b) \theta = 1/3 Fb^2/EJ$$

$$L_{GF}^{xo} = \int_0^b (1/4 - 1/2 x/b + 1/4 x^2/b^2) Fb 1/EJ dx + \int_0^b (-1/2 + 1/2 x/b) \theta dx$$

$$= [1/4 x - 1/4 x^2/b + 1/12 x^3/b^2]_0^b Fb 1/EJ + [-1/2 x + 1/4 x^2/b]_0^b \theta$$

$$= (1/4 b - 1/4 b + 1/12 b) Fb 1/EJ + (-1/2 b + 1/4 b) \theta = 1/3 Fb^2/EJ$$

$$L_{GD}^{xo} = \int_0^b (3/2 x/b - x^2/b^2 - 1/2 x^3/b^3) Fb 1/EJ dx = [3/4 x^2/b - 1/3 x^3/b^2 - 1/8 x^4/b^3]_0^b Fb 1/EJ$$

$$= (3/4 b - 1/3 b - 1/8 b) Fb 1/EJ = 7/24 Fb^2/EJ$$

$$L_{DG}^{xo} = \int_0^b (2 x/b - 5/2 x^2/b^2 + 1/2 x^3/b^3) Fb 1/EJ dx = [x^2/b - 5/6 x^3/b^2 + 1/8 x^4/b^3]_0^b Fb 1/EJ$$

$$= (b - 5/6 b + 1/8 b) Fb 1/EJ = 7/24 Fb^2/EJ$$

$$L_{GA}^{xo} = \int_0^b (-1/4 + 1/2 x/b - 1/4 x^2/b^2) Fb 1/EJ dx = [-1/4 x + 1/4 x^2/b - 1/12 x^3/b^2]_0^b Fb 1/EJ$$

$$= (-1/4 b + 1/4 b - 1/12 b) Fb 1/EJ = -1/12 Fb^2/EJ$$

$$L_{AG}^{xo} = \int_0^b (-1/4 x^2/b^2) Fb 1/EJ dx = [-1/12 x^3/b^2]_0^b Fb 1/EJ$$

$$= (-1/12 b) Fb 1/EJ = -1/12 Fb^2/EJ$$

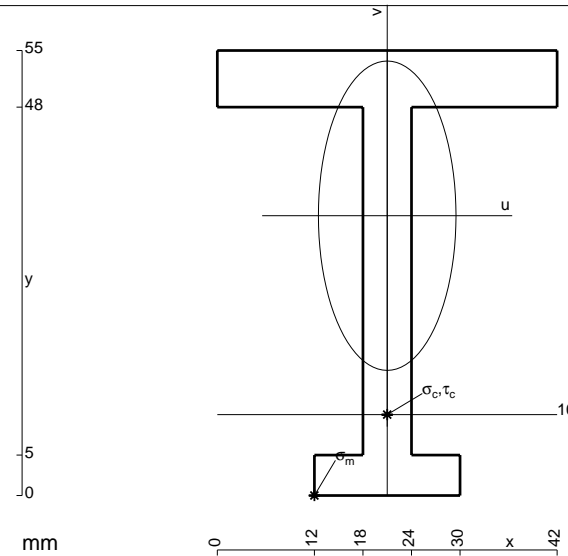

$A = 642. \text{ mm}^2$
 $J_u = 234775. \text{ mm}^4$
 $J_v = 46422. \text{ mm}^4$
 $y_g = 34.58 \text{ mm}$
 $T_y = -2100. \text{ N}$
 $M_x = -1478400. \text{ Nmm}$
 $x_m = 12. \text{ mm}$
 $u_m = -9. \text{ mm}$
 $v_m = -34.58 \text{ mm}$
 $\sigma_m = -Mv/J_u = -217.8 \text{ N/mm}^2$
 $x_c = 21. \text{ mm}$
 $y_c = 10. \text{ mm}$
 $v_c = -24.58 \text{ mm}$
 $\sigma_c = -Mv/J_u = -154.8 \text{ N/mm}^2$
 $\tau_c = 5.516 \text{ N/mm}^2$
 $\sigma_o = \sqrt{\sigma^2 + 3\tau^2} = 155.1 \text{ N/mm}^2$
 $S = 3700. \text{ mm}^3$

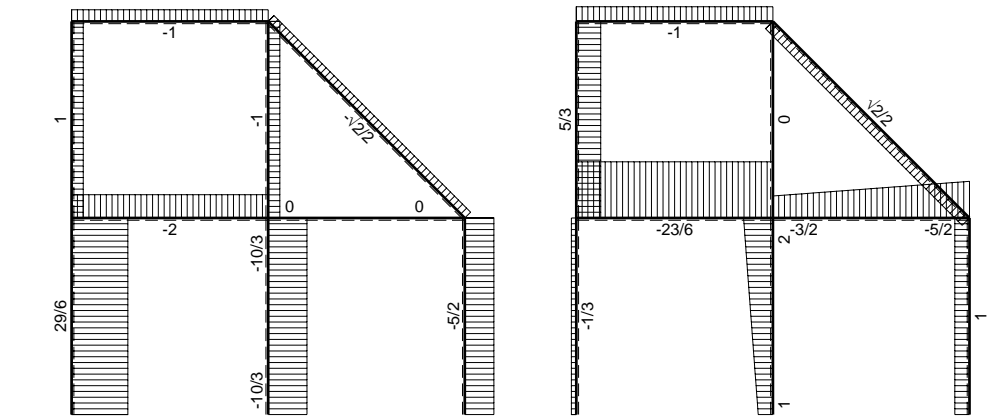
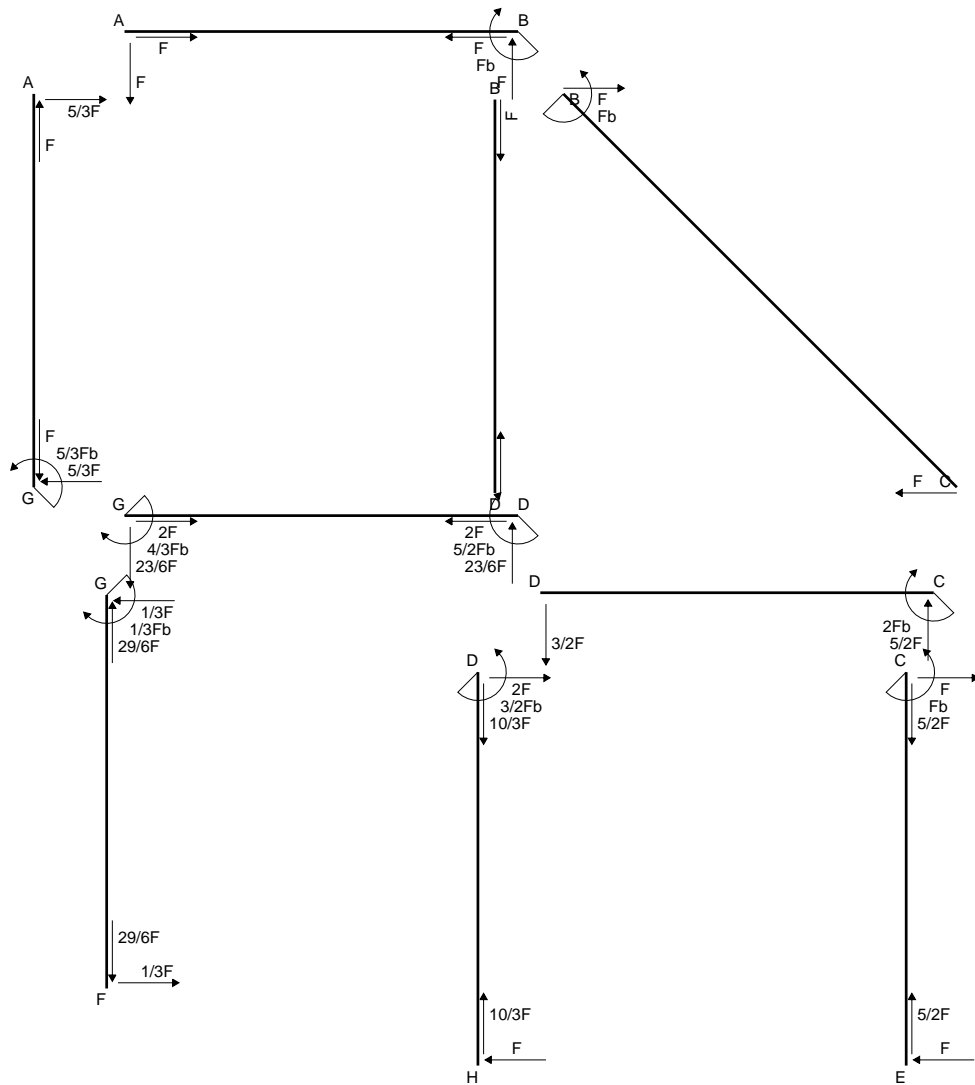

← ⊕ → F

↑ ⊕ ↓ F

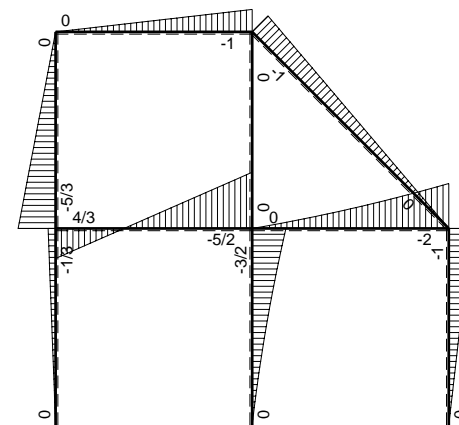

⊕ ⊖ F_b

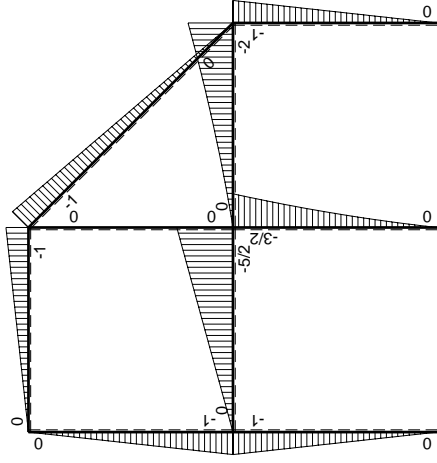
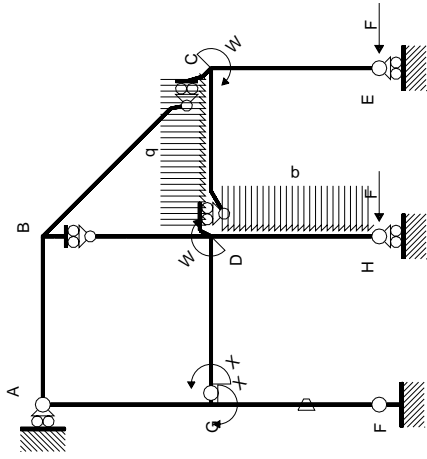

Schema di calcolo iperstatico

M_0 flessione da carichi assegnati

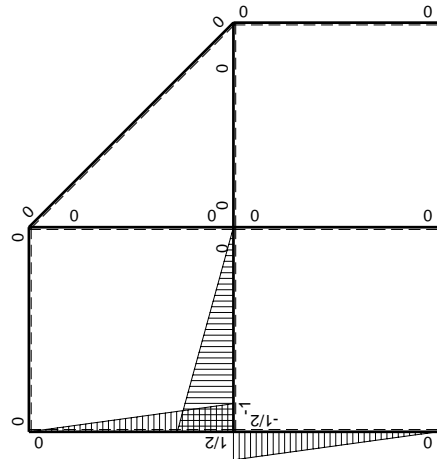

M_1 flessione da iperstatica $X=1$

Quadro contributi PLV per iperstatica $X=W_{GD}$

→	$M_x(x)$	$M_o(x)$	θ	$M_x M_o$	$M_x \theta$	$M_x M_x$	$\int M_x(M_o/EJ+\theta)dx$	$\int X M_x M_x/EJ dx$	
AB b	0	-Fx	0	0	0	0	0+0	0	
BA b	0	Fb-Fx	0	0	0	0	0	0	
BC $\sqrt{2}b$	0	-Fb+ $\sqrt{2}/2Fx$	0	0	0	0	0	0	
BD b	0	0	0	0	0	0	0+0	0	
DB b	0	0	0	0	0	0	0	0	
DC b	0	-3/2Fx-1/2qx ²	0	0	0	0	0+0	0	
CD b	0	2Fb-5/2Fx+1/2qx ²	0	0	0	0	0	0	
CE b	0	-Fb+Fx	0	0	0	0	0+0	0	
EC b	0	Fx	0	0	0	0	0	0	
FG b	-1/2x/b	-Fx	-Fb/EJ	1/2Fx ² /b	1/2Fx/EJ	1/4x ² /b ²	(1/6+1/4)Fb ² /EJ	1/12Xb/EJ	
GF b	1/2-1/2x/b	Fb-Fx	Fb/EJ	1/2Fb-Fx+1/2Fx ² /b	1/2Fb/EJ-1/2Fx/EJ	1/4-1/2x/b+1/4x ² /b ²			
GD b	-1+x/b	-5/2Fx	0	5/2Fx-5/2Fx ² /b	0	1-2x/b+x ² /b ²	(5/12+0)Fb ² /EJ	1/3Xb/EJ	
DG b	x/b	5/2Fb-5/2Fx	0	5/2Fx-5/2Fx ² /b	0	x ² /b ²			
DH b	0	-3/2Fb+2Fx-1/2qx ²	0	0	0	0	0+0	0	
HD b	0	Fx+1/2qx ²	0	0	0	0	0	0	
GA b	1/2-1/2x/b	-Fb+Fx	0	-1/2Fb+Fx-1/2Fx ² /b	0	1/4-1/2x/b+1/4x ² /b ²	(-1/6+0)Fb ² /EJ	1/12Xb/EJ	
AG b	-1/2x/b	Fx	0	-1/2Fx ² /b	0	1/4x ² /b ²			
	totali							2/3Fb ² /EJ	1/2Xb/EJ
	iperstatica $X=W_{GD}$							-4/3Fb	

Sviluppi di calcolo iperstatica

$$L_{FG}^{xx} = \int_0^b (1/4 x^2/b^2) 1/EJ dx = [1/12 x^3/b^2]_0^b 1/EJ$$

$$= (1/12 b) 1/EJ = 1/12 b/EJ$$

$$L_{GF}^{xx} = \int_0^b (1/4 - 1/2 x/b + 1/4 x^2/b^2) 1/EJ dx = [1/4 x - 1/4 x^2/b + 1/12 x^3/b^2]_0^b 1/EJ$$

$$= (1/4 b - 1/4 b + 1/12 b) 1/EJ = 1/12 b/EJ$$

$$L_{GD}^{xx} = \int_0^b (1 - 2 x/b + x^2/b^2) 1/EJ dx = [x - x^2/b + 1/3 x^3/b^2]_0^b 1/EJ$$

$$= (b - b + 1/3 b) 1/EJ = 1/3 b/EJ$$

$$L_{DG}^{xx} = \int_0^b (x^2/b^2) 1/EJ dx = [1/3 x^3/b^2]_0^b 1/EJ$$

$$= (1/3 b) 1/EJ = 1/3 b/EJ$$

$$L_{GA}^{xx} = \int_0^b (1/4 - 1/2 x/b + 1/4 x^2/b^2) 1/EJ dx = [1/4 x - 1/4 x^2/b + 1/12 x^3/b^2]_0^b 1/EJ$$

$$= (1/4 b - 1/4 b + 1/12 b) 1/EJ = 1/12 b/EJ$$

$$L_{AG}^{xx} = \int_0^b (1/4 x^2/b^2) 1/EJ dx = [1/12 x^3/b^2]_0^b 1/EJ$$

$$= (1/12 b) 1/EJ = 1/12 b/EJ$$

$$L_{FG}^{xo} = \int_0^b (1/2 x^2/b^2) Fb 1/EJ dx + \int_0^b (1/2 x/b) \theta dx = [1/6 x^3/b^2]_0^b Fb 1/EJ + [1/4 x^2/b]_0^b \theta$$

$$= (1/6 b) Fb 1/EJ + (1/4 b) \theta = 5/12 Fb^2/EJ$$

$$L_{GF}^{xo} = \int_0^b (1/2 - x/b + 1/2 x^2/b^2) Fb 1/EJ dx + \int_0^b (-1/2 + 1/2 x/b) \theta dx$$

$$= [1/2 x - 1/2 x^2/b + 1/6 x^3/b^2]_0^b Fb 1/EJ + [-1/2 x + 1/4 x^2/b]_0^b \theta$$

$$= (1/2 b - 1/2 b + 1/6 b) Fb 1/EJ + (-1/2 b + 1/4 b) \theta = 5/12 Fb^2/EJ$$

$$L_{GD}^{xo} = \int_0^b (5/2 x/b - 5/2 x^2/b^2) Fb 1/EJ dx = [5/4 x^2/b - 5/6 x^3/b^2]_0^b Fb 1/EJ$$

$$= (5/4 b - 5/6 b) Fb 1/EJ = 5/12 Fb^2/EJ$$

$$L_{DG}^{xo} = \int_0^b (5/2 x/b - 5/2 x^2/b^2) Fb 1/EJ dx = [5/4 x^2/b - 5/6 x^3/b^2]_0^b Fb 1/EJ$$

$$= (5/4 b - 5/6 b) Fb 1/EJ = 5/12 Fb^2/EJ$$

$$L_{GA}^{xo} = \int_0^b (-1/2 + x/b - 1/2 x^2/b^2) Fb 1/EJ dx = [-1/2 x + 1/2 x^2/b - 1/6 x^3/b^2]_0^b Fb 1/EJ$$

$$= (-1/2 b + 1/2 b - 1/6 b) Fb 1/EJ = -1/6 Fb^2/EJ$$

$$L_{AG}^{xo} = \int_0^b (-1/2 x^2/b^2) Fb 1/EJ dx = [-1/6 x^3/b^2]_0^b Fb 1/EJ$$

$$= (-1/6 b) Fb 1/EJ = -1/6 Fb^2/EJ$$

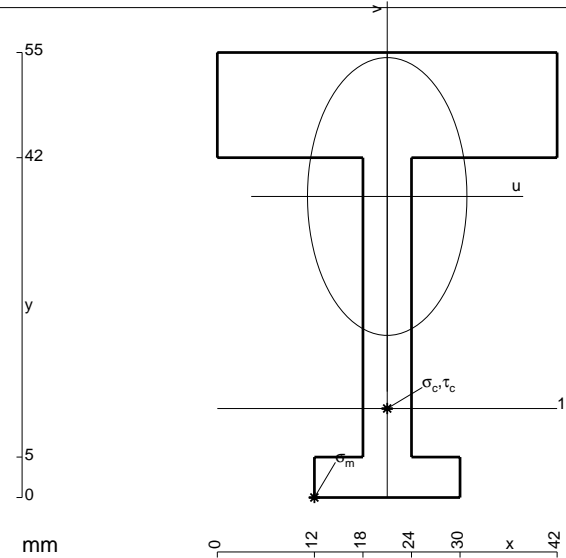

- A = 858. mm²
- J_u = 252957. mm⁴
- J_v = 83358. mm⁴
- y_g = 37.21 mm
- T_y = -2100. N
- M_x = -1562400. Nmm
- x_m = 12. mm
- u_m = -9. mm
- v_m = -37.21 mm
- σ_m = -Mv/J_u = -229.8 N/mm²
- x_c = 21. mm
- y_c = 11. mm
- v_c = -26.21 mm
- σ_c = -Mv/J_u = -161.9 N/mm²
- τ_c = 5.777 N/mm²
- σ_o = √σ²+3τ² = 162.2 N/mm²
- S = 4175. mm³

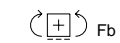
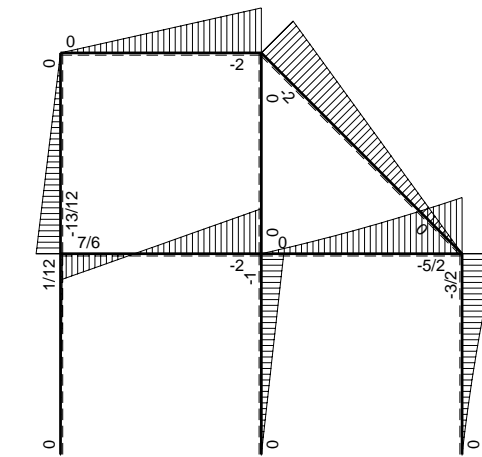
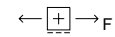
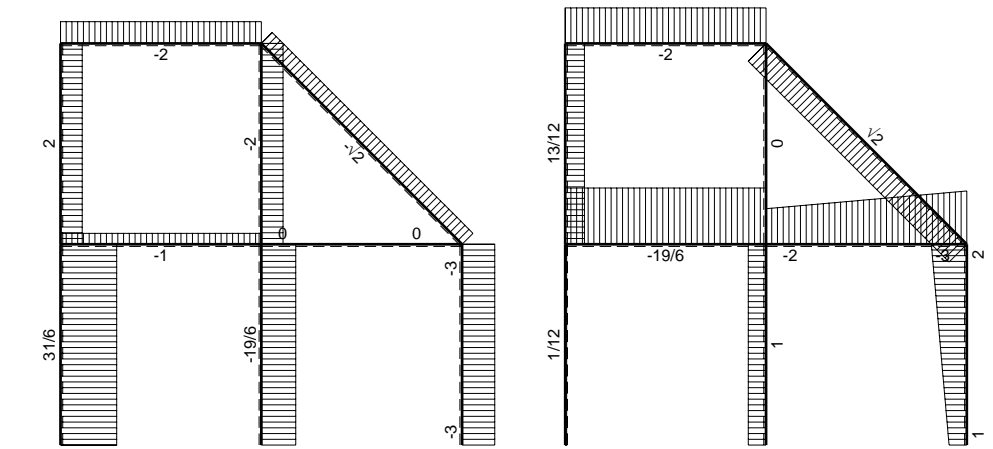
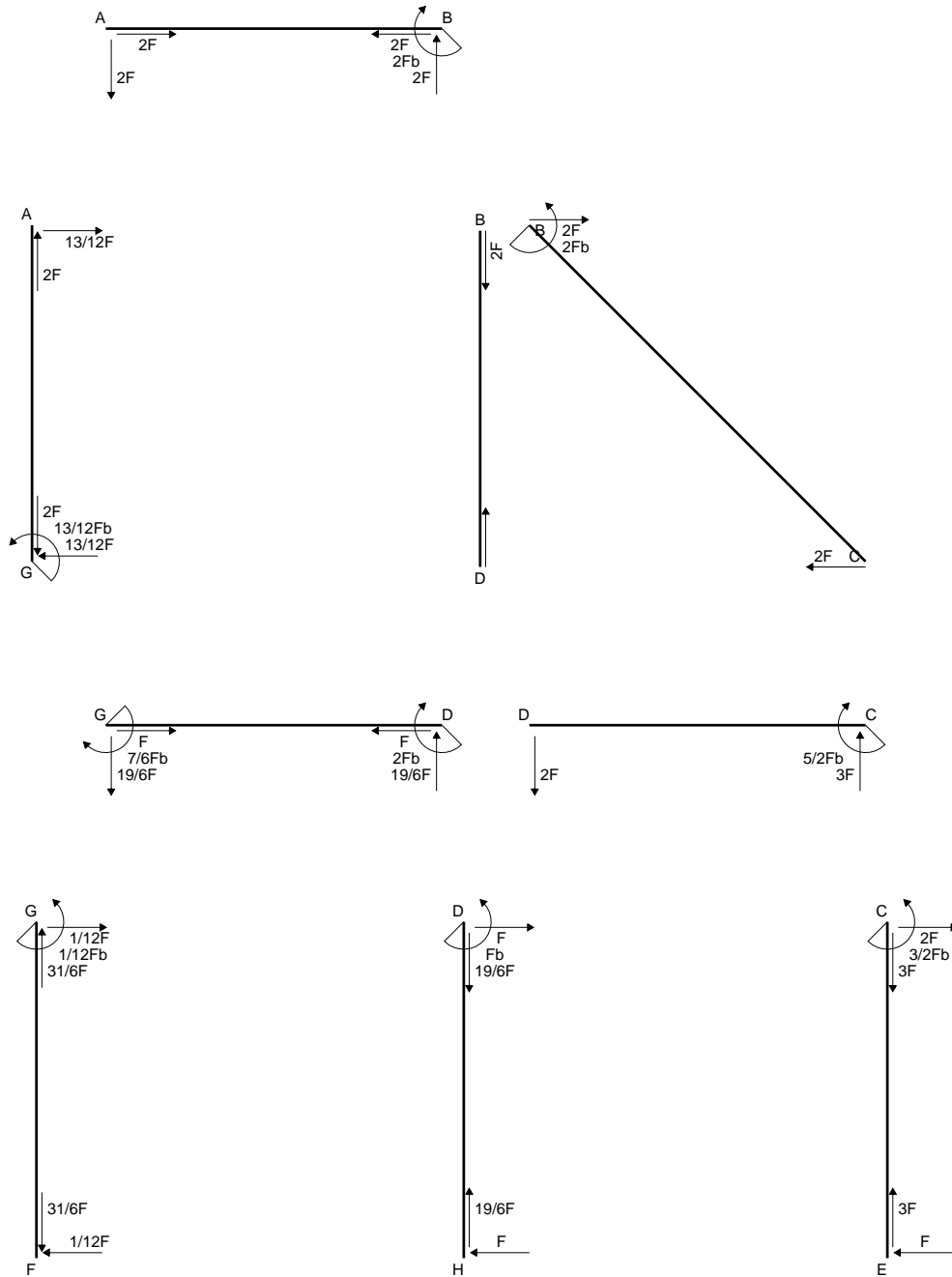

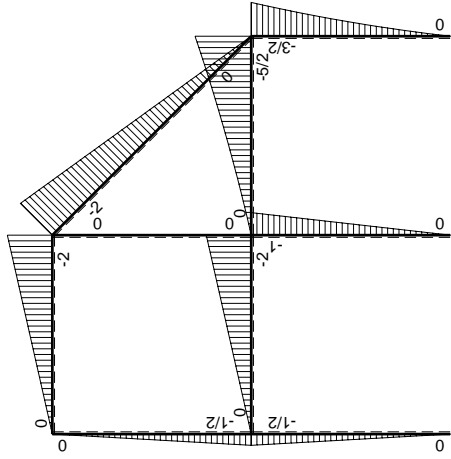
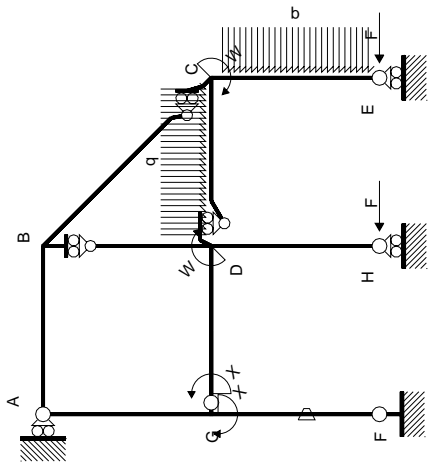

Schema di calcolo iperstatico

M_0 , flessione da carichi assegnati

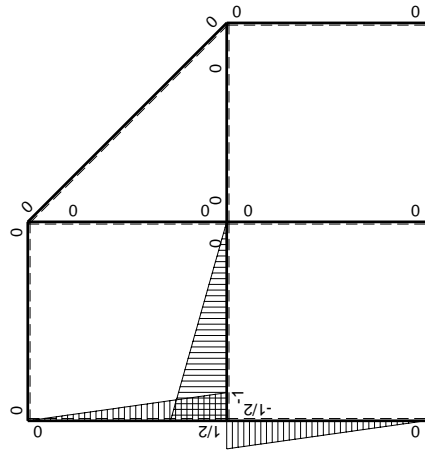

M_x , flessione da iperstatica $X=1$

Quadro contributi PLV per iperstatica $X=W_{GD}$

→	$M_x(x)$	$M_o(x)$	θ	$M_x M_o$	$M_x \theta$	$M_x M_x$	$\int M_x(M_o/EJ+\theta)dx$	$\int X M_x M_x/EJ dx$	
AB b	0	-2Fx	0	0	0	0	0+0	0	
BA b	0	2Fb-2Fx	0	0	0	0			
BC $\sqrt{2}b$	0	-2Fb+ $\sqrt{2}Fx$	0	0	0	0	0	0	
BD b	0	0	0	0	0	0	0+0	0	
DB b	0	0	0	0	0	0			
DC b	0	-2Fx-1/2qx ²	0	0	0	0	0+0	0	
CD b	0	5/2Fb-3Fx+1/2qx ²	0	0	0	0			
CE b	0	-3/2Fb+2Fx-1/2qx ²	0	0	0	0	0+0	0	
EC b	0	Fx+1/2qx ²	0	0	0	0			
FG b	-1/2x/b	-1/2Fx	-Fb/EJ	1/4Fx ² /b	1/2Fx/EJ	1/4x ² /b ²	(1/12+1/4)Fb ² /EJ	1/12Xb/EJ	
GF b	1/2-1/2x/b	1/2Fb-1/2Fx	Fb/EJ	1/4Fb-1/2Fx+1/4Fx ² /b	1/2Fb/EJ-1/2Fx/EJ	1/4-1/2x/b+1/4x ² /b ²			
GD b	-1+x/b	-2Fx	0	2Fx-2Fx ² /b	0	1-2x/b+x ² /b ²	(1/3+0)Fb ² /EJ	1/3Xb/EJ	
DG b	x/b	2Fb-2Fx	0	2Fx-2Fx ² /b	0	x ² /b ²			
DH b	0	-Fb+Fx	0	0	0	0	0+0	0	
HD b	0	Fx	0	0	0	0			
GA b	1/2-1/2x/b	-1/2Fb+1/2Fx	0	-1/4Fb+1/2Fx-1/4Fx ² /b	0	1/4-1/2x/b+1/4x ² /b ²	(-1/12+0)Fb ² /EJ	1/12Xb/EJ	
AG b	-1/2x/b	1/2Fx	0	-1/4Fx ² /b	0	1/4x ² /b ²			
	totali							7/12Fb ² /EJ	1/2Xb/EJ
	iperstatica $X=W_{GD}$							-7/6Fb	

Sviluppi di calcolo iperstatica

$$L_{FG}^{xx} = \int_0^b (1/4 x^2/b^2) 1/EJ dx = [1/12 x^3/b^2]_0^b 1/EJ$$

$$= (1/12 b) 1/EJ = 1/12 b/EJ$$

$$L_{GF}^{xx} = \int_0^b (1/4 - 1/2 x/b + 1/4 x^2/b^2) 1/EJ dx = [1/4 x - 1/4 x^2/b + 1/12 x^3/b^2]_0^b 1/EJ$$

$$= (1/4 b - 1/4 b + 1/12 b) 1/EJ = 1/12 b/EJ$$

$$L_{GD}^{xx} = \int_0^b (1 - 2 x/b + x^2/b^2) 1/EJ dx = [x - x^2/b + 1/3 x^3/b^2]_0^b 1/EJ$$

$$= (b - b + 1/3 b) 1/EJ = 1/3 b/EJ$$

$$L_{DG}^{xx} = \int_0^b (x^2/b^2) 1/EJ dx = [1/3 x^3/b^2]_0^b 1/EJ$$

$$= (1/3 b) 1/EJ = 1/3 b/EJ$$

$$L_{GA}^{xx} = \int_0^b (1/4 - 1/2 x/b + 1/4 x^2/b^2) 1/EJ dx = [1/4 x - 1/4 x^2/b + 1/12 x^3/b^2]_0^b 1/EJ$$

$$= (1/4 b - 1/4 b + 1/12 b) 1/EJ = 1/12 b/EJ$$

$$L_{AG}^{xx} = \int_0^b (1/4 x^2/b^2) 1/EJ dx = [1/12 x^3/b^2]_0^b 1/EJ$$

$$= (1/12 b) 1/EJ = 1/12 b/EJ$$

$$L_{FG}^{xo} = \int_0^b (1/4 x^2/b^2) Fb 1/EJ dx + \int_0^b (1/2 x/b) \theta dx = [1/12 x^3/b^2]_0^b Fb 1/EJ + [1/4 x^2/b]_0^b \theta$$

$$= (1/12 b) Fb 1/EJ + (1/4 b) \theta = 1/3 Fb^2/EJ$$

$$L_{GF}^{xo} = \int_0^b (1/4 - 1/2 x/b + 1/4 x^2/b^2) Fb 1/EJ dx + \int_0^b (-1/2 + 1/2 x/b) \theta dx$$

$$= [1/4 x - 1/4 x^2/b + 1/12 x^3/b^2]_0^b Fb 1/EJ + [-1/2 x + 1/4 x^2/b]_0^b \theta$$

$$= (1/4 b - 1/4 b + 1/12 b) Fb 1/EJ + (-1/2 b + 1/4 b) \theta = 1/3 Fb^2/EJ$$

$$L_{GD}^{xo} = \int_0^b (2 x/b - 2 x^2/b^2) Fb 1/EJ dx = [x^2/b - 2/3 x^3/b^2]_0^b Fb 1/EJ$$

$$= (b - 2/3 b) Fb 1/EJ = 1/3 Fb^2/EJ$$

$$L_{DG}^{xo} = \int_0^b (2 x/b - 2 x^2/b^2) Fb 1/EJ dx = [x^2/b - 2/3 x^3/b^2]_0^b Fb 1/EJ$$

$$= (b - 2/3 b) Fb 1/EJ = 1/3 Fb^2/EJ$$

$$L_{GA}^{xo} = \int_0^b (-1/4 + 1/2 x/b - 1/4 x^2/b^2) Fb 1/EJ dx = [-1/4 x + 1/4 x^2/b - 1/12 x^3/b^2]_0^b Fb 1/EJ$$

$$= (-1/4 b + 1/4 b - 1/12 b) Fb 1/EJ = -1/12 Fb^2/EJ$$

$$L_{AG}^{xo} = \int_0^b (-1/4 x^2/b^2) Fb 1/EJ dx = [-1/12 x^3/b^2]_0^b Fb 1/EJ$$

$$= (-1/12 b) Fb 1/EJ = -1/12 Fb^2/EJ$$

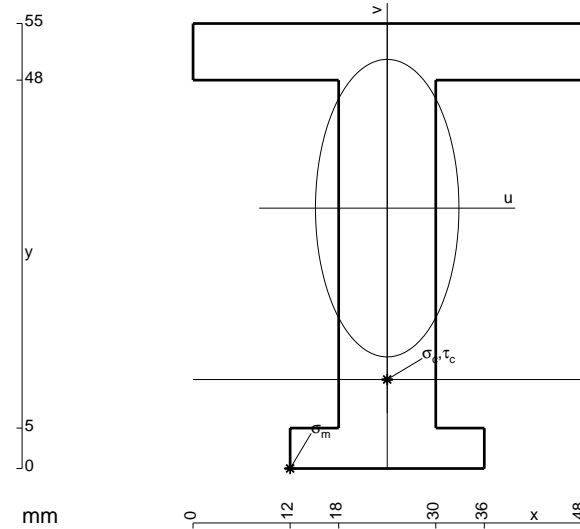

- A = 972. mm²
- J_u = 328901. mm⁴
- J_v = 76464. mm⁴
- y_g = 32.18 mm
- T_y = -3000. N
- M_x = -2450000. Nmm
- x_m = 12. mm
- u_m = -12. mm
- v_m = -32.18 mm
- σ_m = -Mv/J_u = -239.7 N/mm²
- x_c = 24. mm
- y_c = 11. mm
- v_c = -21.18 mm
- σ_c = -Mv/J_u = -157.8 N/mm²
- τ_c = 4.03 N/mm²
- σ_o = √σ²+3τ² = 157.9 N/mm²
- S = 5302. mm³

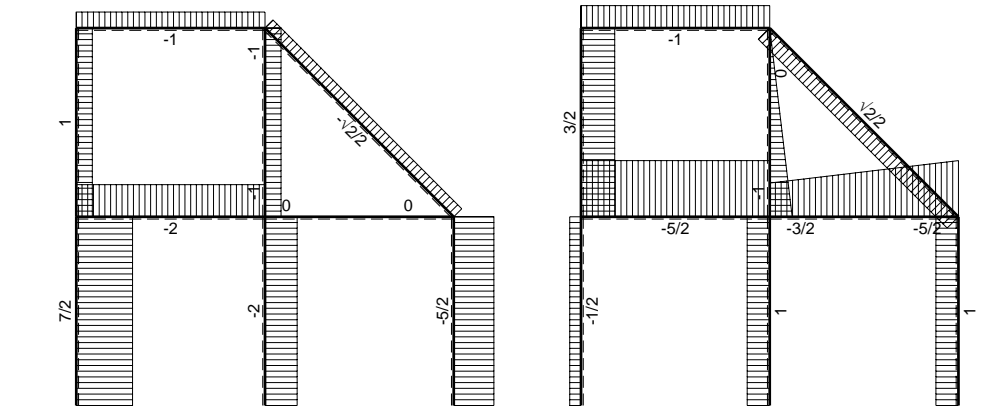
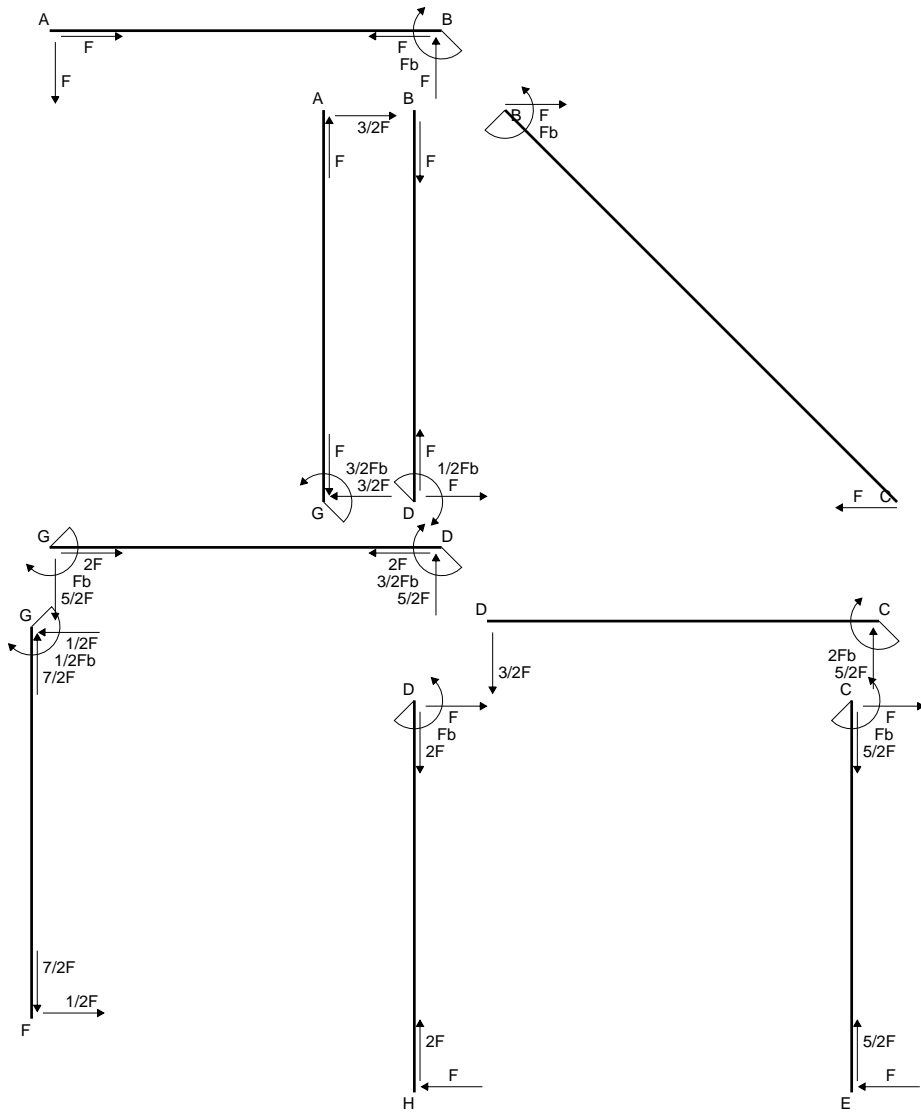

← ⊕ → F

↑ ⊕ ↓ F

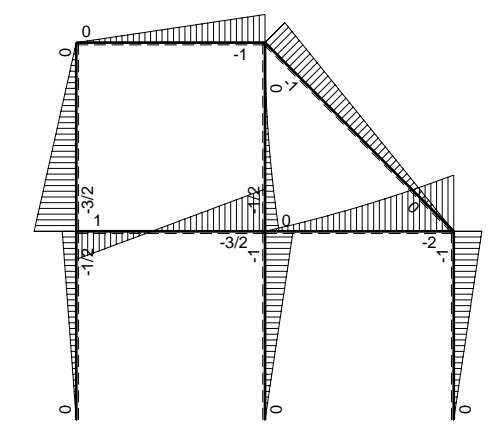

⊕ ⊖ F_b

Quadro contributi PLV per iperstatica $X=W_{GD}$

→	$M_x(x)$	$M_o(x)$	θ	$M_x M_o$	$M_x \theta$	$M_x M_x$	$\int M_x(M_o/EJ+\theta)dx$	$\int x M_x M_x/EJ dx$
AB b	0	-Fx	0	0	0	0	0+0	0
BA b	0	Fb-Fx	0	0	0	0		
BC $\sqrt{2}b$	0	-Fb+ $\sqrt{2}/2Fx$	0	0	0	0	0	0
BD b	0	-1/2qx ²	0	0	0	0	0+0	0
DB b	0	1/2Fb-Fx+1/2qx ²	0	0	0	0		
DC b	0	-3/2Fx-1/2qx ²	0	0	0	0	0+0	0
CD b	0	2Fb-5/2Fx+1/2qx ²	0	0	0	0		
CE b	0	-Fb+Fx	0	0	0	0	0+0	0
EC b	0	Fx	0	0	0	0		
FG b	-1/2x/b	-Fx	-Fb/EJ	1/2Fx ² /b	1/2Fx/EJ	1/4x ² /b ²	(1/6+1/4)Fb ² /EJ	1/12Xb/EJ
GF b	1/2-1/2x/b	Fb-Fx	Fb/EJ	1/2Fb-Fx+1/2Fx ² /b	1/2Fb/EJ-1/2Fx/EJ	1/4-1/2x/b+1/4x ² /b ²		
GD b	-1+x/b	-3/2Fx	0	3/2Fx-3/2Fx ² /b	0	1-2x/b+x ² /b ²	(1/4+0)Fb ² /EJ	1/3Xb/EJ
DG b	x/b	3/2Fb-3/2Fx	0	3/2Fx-3/2Fx ² /b	0	x ² /b ²		
DH b	0	-Fb+Fx	0	0	0	0	0+0	0
HD b	0	Fx	0	0	0	0		
GA b	1/2-1/2x/b	-Fb+Fx	0	-1/2Fb+Fx-1/2Fx ² /b	0	1/4-1/2x/b+1/4x ² /b ²	(-1/6+0)Fb ² /EJ	1/12Xb/EJ
AG b	-1/2x/b	Fx	0	-1/2Fx ² /b	0	1/4x ² /b ²		
	totali						1/2Fb ² /EJ	1/2Xb/EJ
	iperstatica $X=W_{GD}$						-Fb	

Sviluppi di calcolo iperstatica

$$L_{FG}^{xx} = \int_0^b (1/4 x^2/b^2) 1/EJ dx = [1/12 x^3/b^2]_0^b 1/EJ$$

$$= (1/12 b) 1/EJ = 1/12 b/EJ$$

$$L_{GF}^{xx} = \int_0^b (1/4 - 1/2 x/b + 1/4 x^2/b^2) 1/EJ dx = [1/4 x - 1/4 x^2/b + 1/12 x^3/b^2]_0^b 1/EJ$$

$$= (1/4 b - 1/4 b + 1/12 b) 1/EJ = 1/12 b/EJ$$

$$L_{GD}^{xx} = \int_0^b (1 - 2 x/b + x^2/b^2) 1/EJ dx = [x - x^2/b + 1/3 x^3/b^2]_0^b 1/EJ$$

$$= (b - b + 1/3 b) 1/EJ = 1/3 b/EJ$$

$$L_{DG}^{xx} = \int_0^b (x^2/b^2) 1/EJ dx = [1/3 x^3/b^2]_0^b 1/EJ$$

$$= (1/3 b) 1/EJ = 1/3 b/EJ$$

$$L_{GA}^{xx} = \int_0^b (1/4 - 1/2 x/b + 1/4 x^2/b^2) 1/EJ dx = [1/4 x - 1/4 x^2/b + 1/12 x^3/b^2]_0^b 1/EJ$$

$$= (1/4 b - 1/4 b + 1/12 b) 1/EJ = 1/12 b/EJ$$

$$L_{AG}^{xx} = \int_0^b (1/4 x^2/b^2) 1/EJ dx = [1/12 x^3/b^2]_0^b 1/EJ$$

$$= (1/12 b) 1/EJ = 1/12 b/EJ$$

$$L_{FG}^{xo} = \int_0^b (1/2 x^2/b^2) Fb 1/EJ dx + \int_0^b (1/2 x/b) \theta dx = [1/6 x^3/b^2]_0^b Fb 1/EJ + [1/4 x^2/b]_0^b \theta$$

$$= (1/6 b) Fb 1/EJ + (1/4 b) \theta = 5/12 Fb^2/EJ$$

$$L_{GF}^{xo} = \int_0^b (1/2 - x/b + 1/2 x^2/b^2) Fb 1/EJ dx + \int_0^b (-1/2 + 1/2 x/b) \theta dx$$

$$= [1/2 x - 1/2 x^2/b + 1/6 x^3/b^2]_0^b Fb 1/EJ + [-1/2 x + 1/4 x^2/b]_0^b \theta$$

$$= (1/2 b - 1/2 b + 1/6 b) Fb 1/EJ + (-1/2 b + 1/4 b) \theta = 5/12 Fb^2/EJ$$

$$L_{GD}^{xo} = \int_0^b (3/2 x/b - 3/2 x^2/b^2) Fb 1/EJ dx = [3/4 x^2/b - 1/2 x^3/b^2]_0^b Fb 1/EJ$$

$$= (3/4 b - 1/2 b) Fb 1/EJ = 1/4 Fb^2/EJ$$

$$L_{DG}^{xo} = \int_0^b (3/2 x/b - 3/2 x^2/b^2) Fb 1/EJ dx = [3/4 x^2/b - 1/2 x^3/b^2]_0^b Fb 1/EJ$$

$$= (3/4 b - 1/2 b) Fb 1/EJ = 1/4 Fb^2/EJ$$

$$L_{GA}^{xo} = \int_0^b (-1/2 + x/b - 1/2 x^2/b^2) Fb 1/EJ dx = [-1/2 x + 1/2 x^2/b - 1/6 x^3/b^2]_0^b Fb 1/EJ$$

$$= (-1/2 b + 1/2 b - 1/6 b) Fb 1/EJ = -1/6 Fb^2/EJ$$

$$L_{AG}^{xo} = \int_0^b (-1/2 x^2/b^2) Fb 1/EJ dx = [-1/6 x^3/b^2]_0^b Fb 1/EJ$$

$$= (-1/6 b) Fb 1/EJ = -1/6 Fb^2/EJ$$

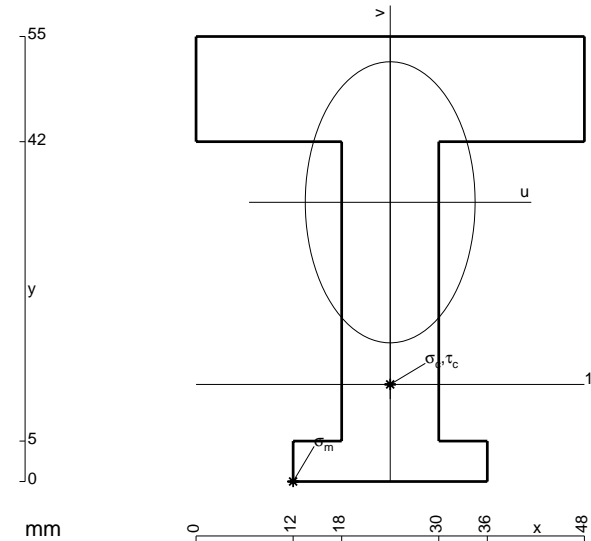

$$A = 1188. \text{ mm}^2$$

$$J_u = 358599. \text{ mm}^4$$

$$J_v = 130896. \text{ mm}^4$$

$$y_g = 34.51 \text{ mm}$$

$$T_y = -4975. \text{ N}$$

$$M_x = -2069600. \text{ Nmm}$$

$$x_m = 12. \text{ mm}$$

$$u_m = -12. \text{ mm}$$

$$v_m = -34.51 \text{ mm}$$

$$\sigma_m = -Mv/J_u = -199.2 \text{ N/mm}^2$$

$$x_c = 24. \text{ mm}$$

$$y_c = 12. \text{ mm}$$

$$v_c = -22.51 \text{ mm}$$

$$\sigma_c = -Mv/J_u = -129.9 \text{ N/mm}^2$$

$$\tau_c = 6.967 \text{ N/mm}^2$$

$$\sigma_o = \sqrt{\sigma^2 + 3\tau^2} = 130.5 \text{ N/mm}^2$$

$$S = 6026. \text{ mm}^3$$

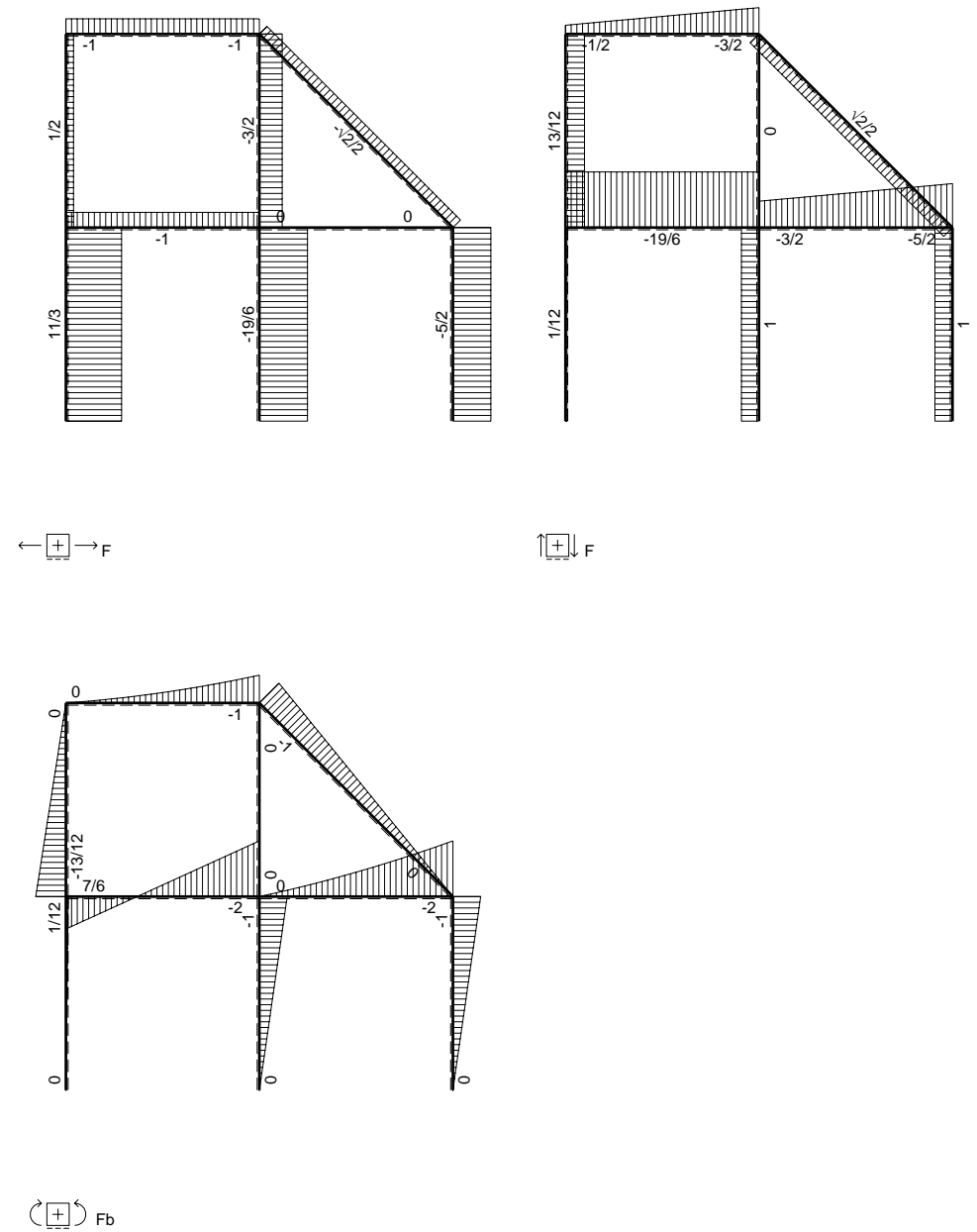
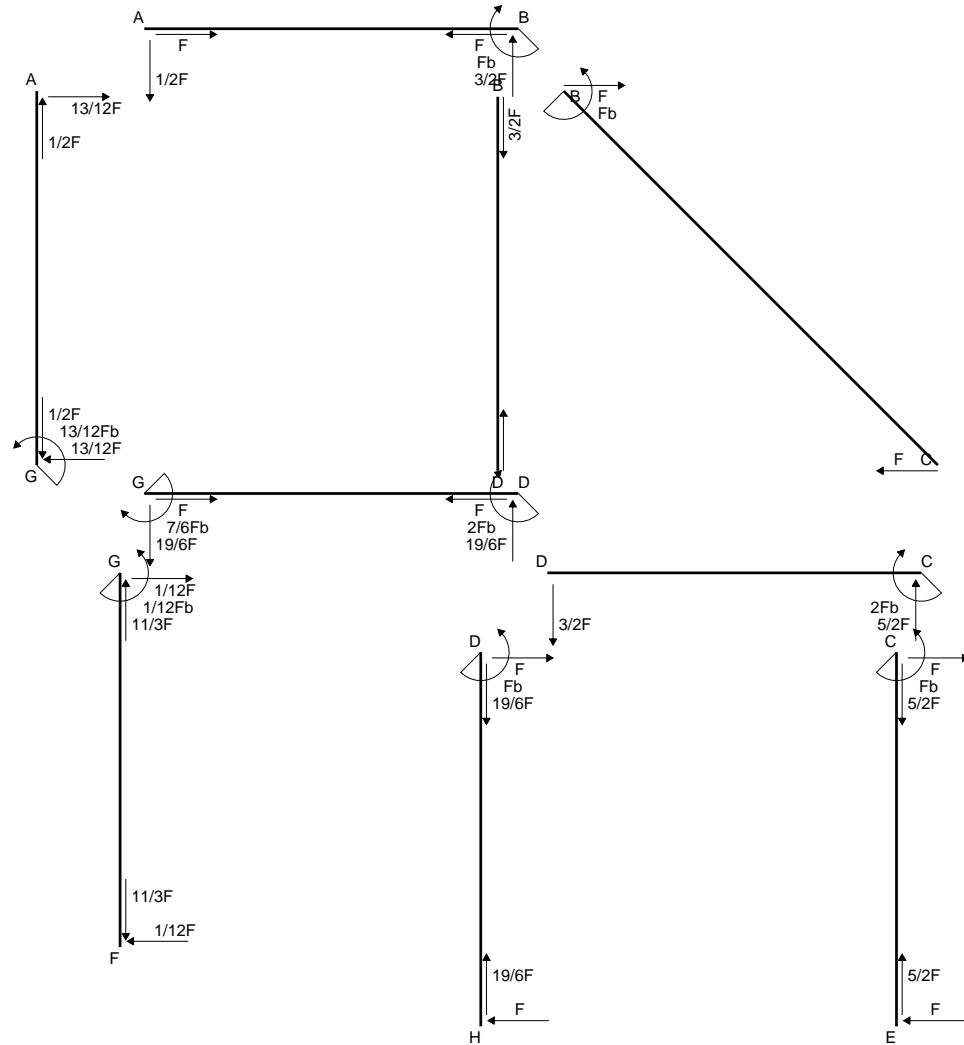

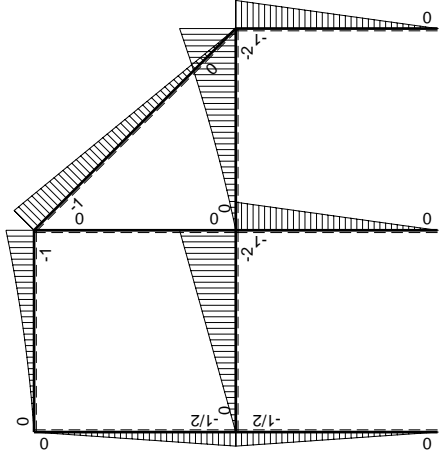
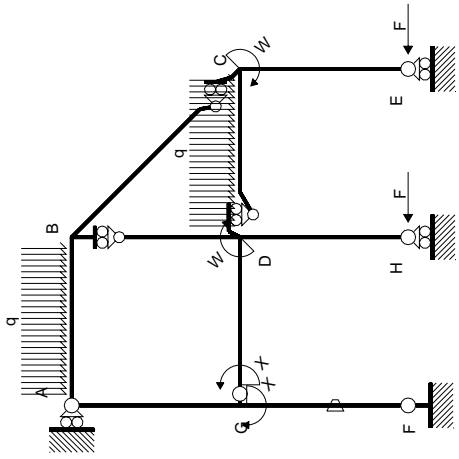

Schema di calcolo iperstatico

M_0 flessione da carichi assegnati

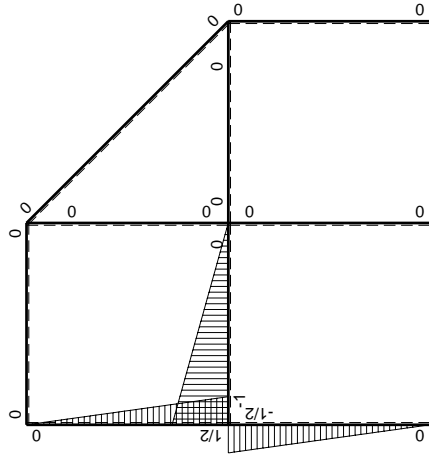

M_x flessione da iperstatica $X=1$

Quadro contributi PLV per iperstatica $X=W_{GD}$

→	$M_x(x)$	$M_o(x)$	θ	$M_x M_o$	$M_x \theta$	$M_x M_x$	$\int M_x(M_o/EJ+\theta)dx$	$\int X M_x M_x/EJdx$
AB b	0	$-1/2Fx-1/2qx^2$	0	0	0	0	0+0	0
BA b	0	$Fb-3/2Fx+1/2qx^2$	0	0	0	0		
BC $\sqrt{2}b$	0	$-Fb+\sqrt{2}/2Fx$	0	0	0	0	0	0
BD b	0	0	0	0	0	0	0+0	0
DB b	0	0	0	0	0	0		
DC b	0	$-3/2Fx-1/2qx^2$	0	0	0	0	0+0	0
CD b	0	$2Fb-5/2Fx+1/2qx^2$	0	0	0	0		
CE b	0	$-Fb+Fx$	0	0	0	0	0+0	0
EC b	0	Fx	0	0	0	0		
FG b	$-1/2x/b$	$-1/2Fx$	$-Fb/EJ$	$1/4Fx^2/b$	$1/2Fx/EJ$	$1/4x^2/b^2$	$(1/12+1/4)Fb^2/EJ$	$1/12Xb/EJ$
GF b	$1/2-1/2x/b$	$1/2Fb-1/2Fx$	Fb/EJ	$1/4Fb-1/2Fx+1/4Fx^2/b$	$1/2Fb/EJ-1/2Fx/EJ$	$1/4-1/2x/b+1/4x^2/b^2$		
GD b	$-1+x/b$	$-2Fx$	0	$2Fx-2Fx^2/b$	0	$1-2x/b+x^2/b^2$	$(1/3+0)Fb^2/EJ$	$1/3Xb/EJ$
DG b	x/b	$2Fb-2Fx$	0	$2Fx-2Fx^2/b$	0	x^2/b^2		
DH b	0	$-Fb+Fx$	0	0	0	0	0+0	0
HD b	0	Fx	0	0	0	0		
GA b	$1/2-1/2x/b$	$-1/2Fb+1/2Fx$	0	$-1/4Fb+1/2Fx-1/4Fx^2/b$	0	$1/4-1/2x/b+1/4x^2/b^2$	$(-1/12+0)Fb^2/EJ$	$1/12Xb/EJ$
AG b	$-1/2x/b$	$1/2Fx$	0	$-1/4Fx^2/b$	0	$1/4x^2/b^2$		
	totali						$7/12Fb^2/EJ$	$1/2Xb/EJ$
	iperstatica $X=W_{GD}$						$-7/6Fb$	

Sviluppi di calcolo iperstatica

$$L_{FG}^{xx} = \int_0^b (1/4 x^2/b^2) 1/EJ dx = [1/12 x^3/b^2]_0^b 1/EJ$$

$$= (1/12 b) 1/EJ = 1/12 b/EJ$$

$$L_{GF}^{xx} = \int_0^b (1/4 -1/2 x/b +1/4 x^2/b^2) 1/EJ dx = [1/4 x -1/4 x^2/b +1/12 x^3/b^2]_0^b 1/EJ$$

$$= (1/4 b -1/4 b +1/12 b) 1/EJ = 1/12 b/EJ$$

$$L_{GD}^{xx} = \int_0^b (1 -2 x/b + x^2/b^2) 1/EJ dx = [x - x^2/b +1/3 x^3/b^2]_0^b 1/EJ$$

$$= (b - b +1/3 b) 1/EJ = 1/3 b/EJ$$

$$L_{DG}^{xx} = \int_0^b (x^2/b^2) 1/EJ dx = [1/3 x^3/b^2]_0^b 1/EJ$$

$$= (1/3 b) 1/EJ = 1/3 b/EJ$$

$$L_{GA}^{xx} = \int_0^b (1/4 -1/2 x/b +1/4 x^2/b^2) 1/EJ dx = [1/4 x -1/4 x^2/b +1/12 x^3/b^2]_0^b 1/EJ$$

$$= (1/4 b -1/4 b +1/12 b) 1/EJ = 1/12 b/EJ$$

$$L_{AG}^{xx} = \int_0^b (1/4 x^2/b^2) 1/EJ dx = [1/12 x^3/b^2]_0^b 1/EJ$$

$$= (1/12 b) 1/EJ = 1/12 b/EJ$$

$$L_{FG}^{xo} = \int_0^b (1/4 x^2/b^2) Fb 1/EJ dx + \int_0^b (1/2 x/b) \theta dx = [1/12 x^3/b^2]_0^b Fb 1/EJ + [1/4 x^2/b]_0^b \theta$$

$$= (1/12 b) Fb 1/EJ + (1/4 b) \theta = 1/3 Fb^2/EJ$$

$$L_{GF}^{xo} = \int_0^b (1/4 -1/2 x/b +1/4 x^2/b^2) Fb 1/EJ dx + \int_0^b (-1/2 +1/2 x/b) \theta dx$$

$$= [1/4 x -1/4 x^2/b +1/12 x^3/b^2]_0^b Fb 1/EJ + [-1/2 x +1/4 x^2/b]_0^b \theta$$

$$= (1/4 b -1/4 b +1/12 b) Fb 1/EJ + (-1/2 b +1/4 b) \theta = 1/3 Fb^2/EJ$$

$$L_{GD}^{xo} = \int_0^b (2 x/b -2 x^2/b^2) Fb 1/EJ dx = [x^2/b -2/3 x^3/b^2]_0^b Fb 1/EJ$$

$$= (b -2/3 b) Fb 1/EJ = 1/3 Fb^2/EJ$$

$$L_{DG}^{xo} = \int_0^b (2 x/b -2 x^2/b^2) Fb 1/EJ dx = [x^2/b -2/3 x^3/b^2]_0^b Fb 1/EJ$$

$$= (b -2/3 b) Fb 1/EJ = 1/3 Fb^2/EJ$$

$$L_{GA}^{xo} = \int_0^b (-1/4 +1/2 x/b -1/4 x^2/b^2) Fb 1/EJ dx = [-1/4 x +1/4 x^2/b -1/12 x^3/b^2]_0^b Fb 1/EJ$$

$$= (-1/4 b +1/4 b -1/12 b) Fb 1/EJ = -1/12 Fb^2/EJ$$

$$L_{AG}^{xo} = \int_0^b (-1/4 x^2/b^2) Fb 1/EJ dx = [-1/12 x^3/b^2]_0^b Fb 1/EJ$$

$$= (-1/12 b) Fb 1/EJ = -1/12 Fb^2/EJ$$

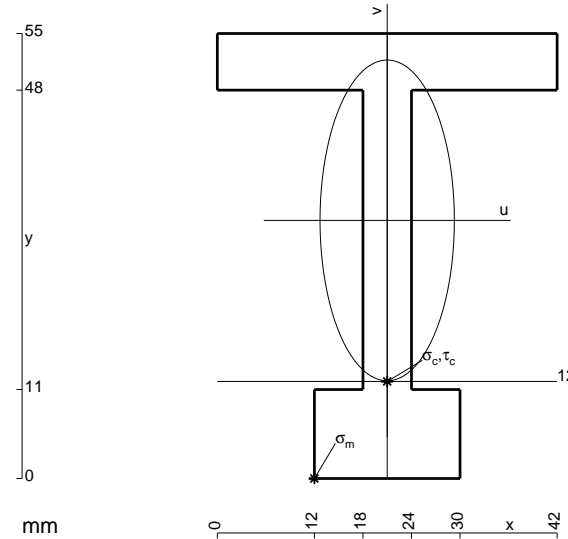

- A = 714. mm²
- J_u = 280743. mm⁴
- J_v = 49230. mm⁴
- y_g = 31.9 mm
- T_y = -4050. N
- M_x = -1846800. Nmm
- x_m = 12. mm
- u_m = -9. mm
- v_m = -31.9 mm
- σ_m = -Mv/J_u = -209.9 N/mm²
- x_c = 21. mm
- y_c = 12. mm
- v_c = -19.9 mm
- σ_c = -Mv/J_u = -130.9 N/mm²
- τ_c = 12.86 N/mm²
- σ_o = √σ²+3τ² = 132.8 N/mm²
- S = 5350. mm³

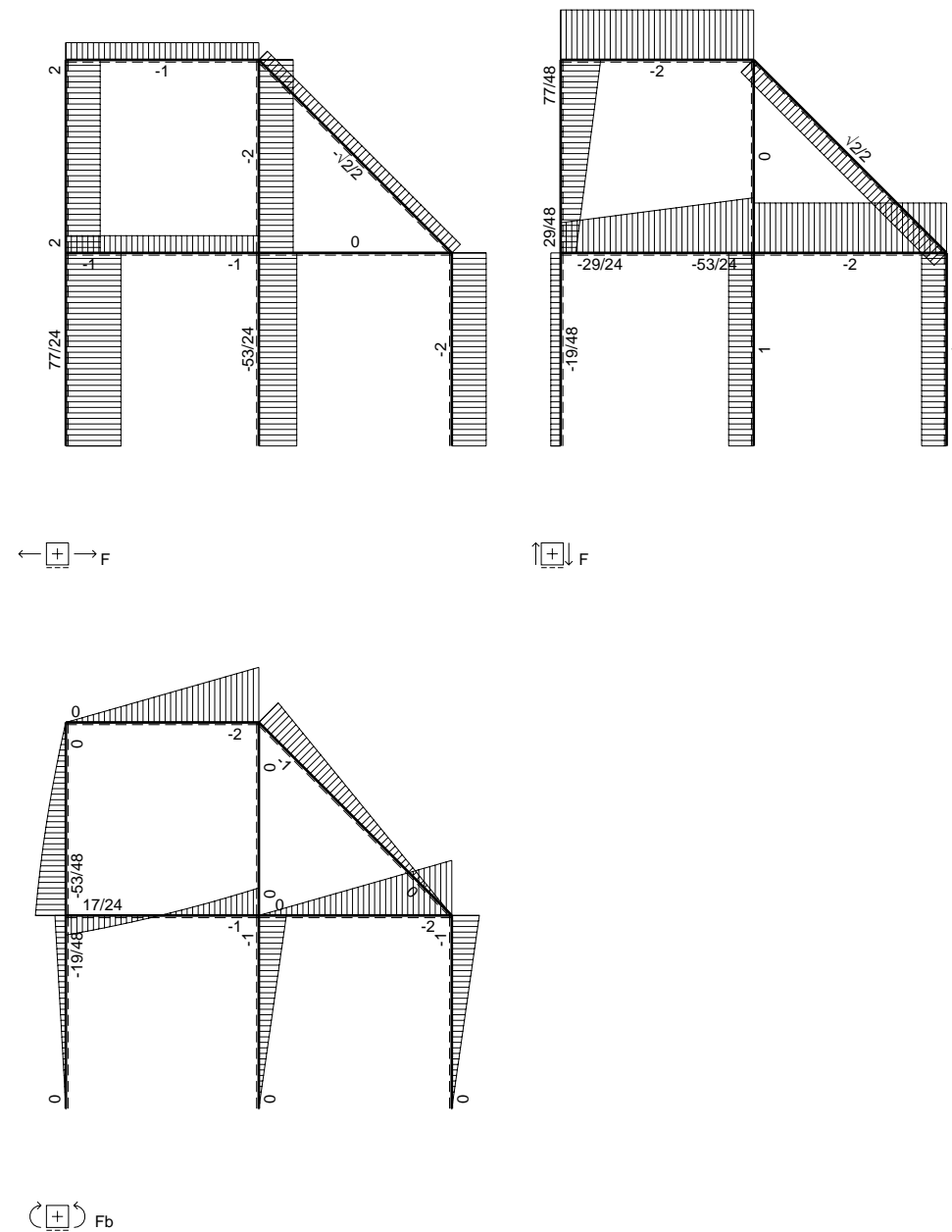
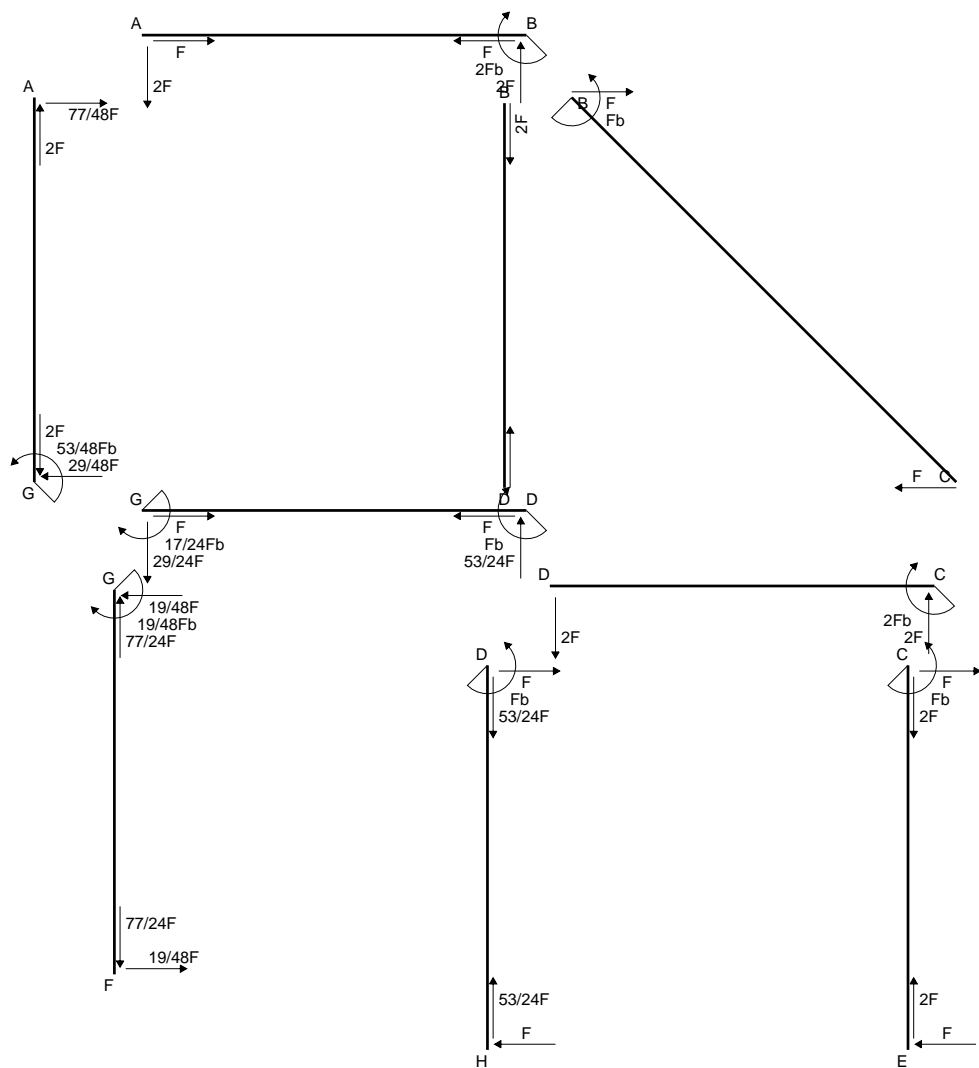

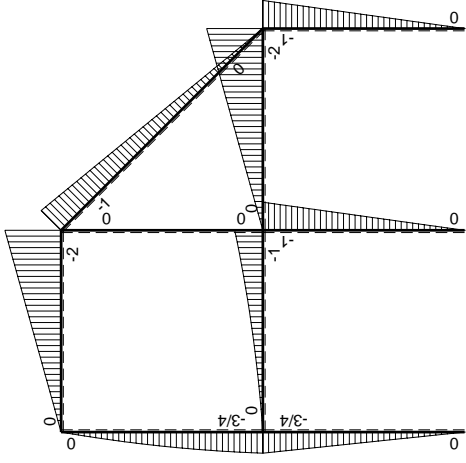
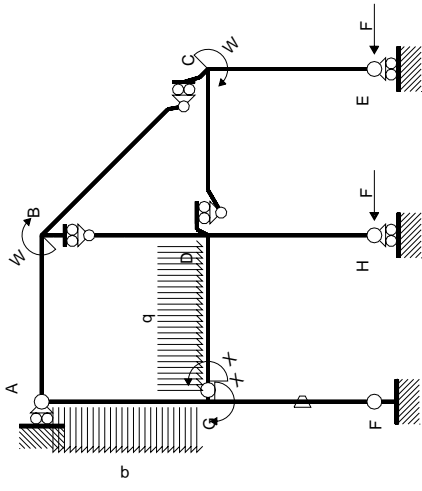

Schema di calcolo iperstatico

M_0 flessione da carichi assegnati

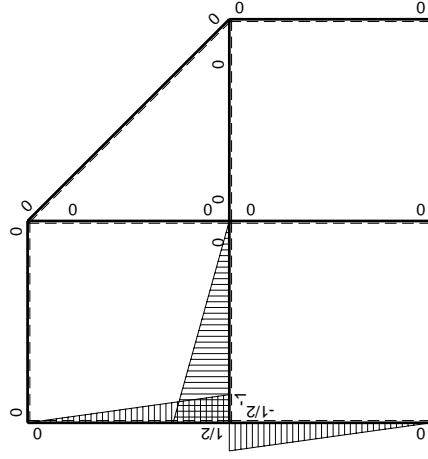

M_x flessione da iperstatica $X=1$

Quadro contributi PLV per iperstatica $X=W_{GD}$

→	$M_x(x)$	$M_o(x)$	θ	$M_x M_o$	$M_x \theta$	$M_x M_x$	$\int M_x(M_o/EJ+\theta)dx$	$\int X M_x M_x/EJdx$	
AB b	0	-2Fx	0	0	0	0	0+0	0	
BA b	0	2Fb-2Fx	0	0	0	0	0	0	
BC $\sqrt{2}b$	0	-Fb+ $\sqrt{2}/2Fx$	0	0	0	0	0	0	
BD b	0	0	0	0	0	0	0+0	0	
DB b	0	0	0	0	0	0	0	0	
DC b	0	-2Fx	0	0	0	0	0+0	0	
CD b	0	2Fb-2Fx	0	0	0	0	0	0	
CE b	0	-Fb+Fx	0	0	0	0	0+0	0	
EC b	0	Fx	0	0	0	0	0	0	
FG b	-1/2x/b	-3/4Fx	-Fb/EJ	$3/8Fx^2/b$	$1/2Fx/EJ$	$1/4x^2/b^2$	$(1/8+1/4)Fb^2/EJ$	$1/12Xb/EJ$	
GF b	$1/2-1/2x/b$	$3/4Fb-3/4Fx$	Fb/EJ	$3/8Fb-3/4Fx+3/8Fx^2/b$	$1/2Fb/EJ-1/2Fx/EJ$	$1/4-1/2x/b+1/4x^2/b^2$			
GD b	-1+x/b	-1/2Fx-1/2qx ²	0	$1/2Fx-1/2qx^3/b$	0	$1-2x/b+x^2/b^2$	$(1/8+0)Fb^2/EJ$	$1/3Xb/EJ$	
DG b	x/b	$Fb-3/2Fx+1/2qx^2$	0	$Fx-3/2Fx^2/b+1/2qx^3/b$	0	x^2/b^2			
DH b	0	-Fb+Fx	0	0	0	0	0+0	0	
HD b	0	Fx	0	0	0	0	0	0	
GA b	$1/2-1/2x/b$	$-3/4Fb+1/4Fx+1/2qx^2$	0	$-3/8Fb+1/2Fx+1/8Fx^2/b-1/4qx^3/b$	0	$1/4-1/2x/b+1/4x^2/b^2$	$(-7/48+0)Fb^2/EJ$	$1/12Xb/EJ$	
AG b	-1/2x/b	$5/4Fx-1/2qx^2$	0	$-5/8Fx^2/b+1/4qx^3/b$	0	$1/4x^2/b^2$			
	totali							$17/48Fb^2/EJ$	$1/2Xb/EJ$
	iperstatica $X=W_{GD}$							-17/24Fb	

Sviluppi di calcolo iperstatica

$$L_{FG}^{xx} = \int_0^b (1/4 x^2/b^2) 1/EJ dx = [1/12 x^3/b^2]_0^b 1/EJ$$

$$= (1/12 b) 1/EJ = 1/12 b/EJ$$

$$L_{GF}^{xx} = \int_0^b (1/4 - 1/2 x/b + 1/4 x^2/b^2) 1/EJ dx = [1/4 x - 1/4 x^2/b + 1/12 x^3/b^2]_0^b 1/EJ$$

$$= (1/4 b - 1/4 b + 1/12 b) 1/EJ = 1/12 b/EJ$$

$$L_{GD}^{xx} = \int_0^b (1 - 2 x/b + x^2/b^2) 1/EJ dx = [x - x^2/b + 1/3 x^3/b^2]_0^b 1/EJ$$

$$= (b - b + 1/3 b) 1/EJ = 1/3 b/EJ$$

$$L_{DG}^{xx} = \int_0^b (x^2/b^2) 1/EJ dx = [1/3 x^3/b^2]_0^b 1/EJ$$

$$= (1/3 b) 1/EJ = 1/3 b/EJ$$

$$L_{GA}^{xx} = \int_0^b (1/4 - 1/2 x/b + 1/4 x^2/b^2) 1/EJ dx = [1/4 x - 1/4 x^2/b + 1/12 x^3/b^2]_0^b 1/EJ$$

$$= (1/4 b - 1/4 b + 1/12 b) 1/EJ = 1/12 b/EJ$$

$$L_{AG}^{xx} = \int_0^b (1/4 x^2/b^2) 1/EJ dx = [1/12 x^3/b^2]_0^b 1/EJ$$

$$= (1/12 b) 1/EJ = 1/12 b/EJ$$

$$L_{FG}^{xo} = \int_0^b (3/8 x^2/b^2) Fb 1/EJ dx + \int_0^b (1/2 x/b) \theta dx = [1/8 x^3/b^2]_0^b Fb 1/EJ + [1/4 x^2/b]_0^b \theta$$

$$= (1/8 b) Fb 1/EJ + (1/4 b) \theta = 3/8 Fb^2/EJ$$

$$L_{GF}^{xo} = \int_0^b (3/8 - 3/4 x/b + 3/8 x^2/b^2) Fb 1/EJ dx + \int_0^b (-1/2 + 1/2 x/b) \theta dx$$

$$= [3/8 x - 3/8 x^2/b + 1/8 x^3/b^2]_0^b Fb 1/EJ + [-1/2 x + 1/4 x^2/b]_0^b \theta$$

$$= (3/8 b - 3/8 b + 1/8 b) Fb 1/EJ + (-1/2 b + 1/4 b) \theta = 3/8 Fb^2/EJ$$

$$L_{GD}^{xo} = \int_0^b (1/2 x/b - 1/2 x^3/b^3) Fb 1/EJ dx = [1/4 x^2/b - 1/8 x^4/b^3]_0^b Fb 1/EJ$$

$$= (1/4 b - 1/8 b) Fb 1/EJ = 1/8 Fb^2/EJ$$

$$L_{DG}^{xo} = \int_0^b (x/b - 3/2 x^2/b^2 + 1/2 x^3/b^3) Fb 1/EJ dx = [1/2 x^2/b - 1/2 x^3/b^2 + 1/8 x^4/b^3]_0^b Fb 1/EJ$$

$$= (1/2 b - 1/2 b + 1/8 b) Fb 1/EJ = 1/8 Fb^2/EJ$$

$$L_{GA}^{xo} = \int_0^b (-3/8 + 1/2 x/b + 1/8 x^2/b^2 - 1/4 x^3/b^3) Fb 1/EJ dx$$

$$= [-3/8 x + 1/4 x^2/b + 1/24 x^3/b^2 - 1/16 x^4/b^3]_0^b Fb 1/EJ$$

$$= (-3/8 b + 1/4 b + 1/24 b - 1/16 b) Fb 1/EJ = -7/48 Fb^2/EJ$$

$$L_{AG}^{xo} = \int_0^b (-5/8 x^2/b^2 + 1/4 x^3/b^3) Fb 1/EJ dx = [-5/24 x^3/b^2 + 1/16 x^4/b^3]_0^b Fb 1/EJ$$

$$= (-5/24 b + 1/16 b) Fb 1/EJ = -7/48 Fb^2/EJ$$

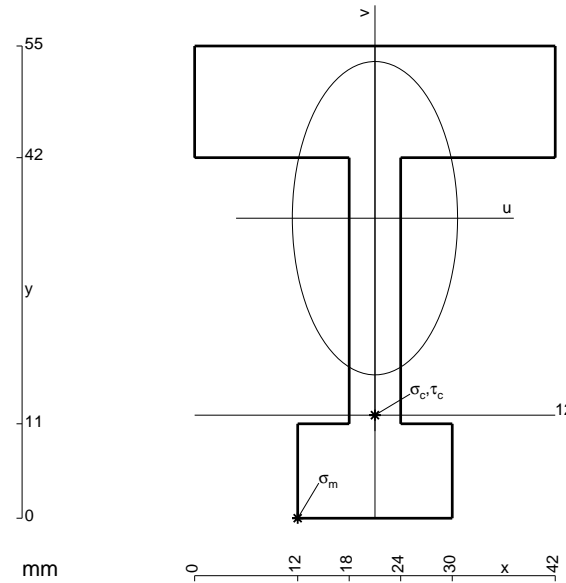

$A = 930. \text{ mm}^2$
 $J_u = 309835. \text{ mm}^4$
 $J_v = 86166. \text{ mm}^4$
 $y_g = 34.95 \text{ mm}$
 $N = -1560. \text{ N}$
 $T_y = -3120. \text{ N}$
 $M_x = -1934400. \text{ Nmm}$
 $x_m = 12. \text{ mm}$
 $u_m = -9. \text{ mm}$
 $v_m = -34.95 \text{ mm}$
 $\sigma_m = N/A - Mv/J_u = -219.9 \text{ N/mm}^2$
 $x_c = 21. \text{ mm}$
 $y_c = 12. \text{ mm}$
 $v_c = -22.95 \text{ mm}$
 $\sigma_c = N/A - Mv/J_u = -144.9 \text{ N/mm}^2$
 $\tau_c = 10.02 \text{ N/mm}^2$
 $\sigma_o = \sqrt{\sigma^2 + 3\tau^2} = 146. \text{ N/mm}^2$
 $S = 5971. \text{ mm}^3$

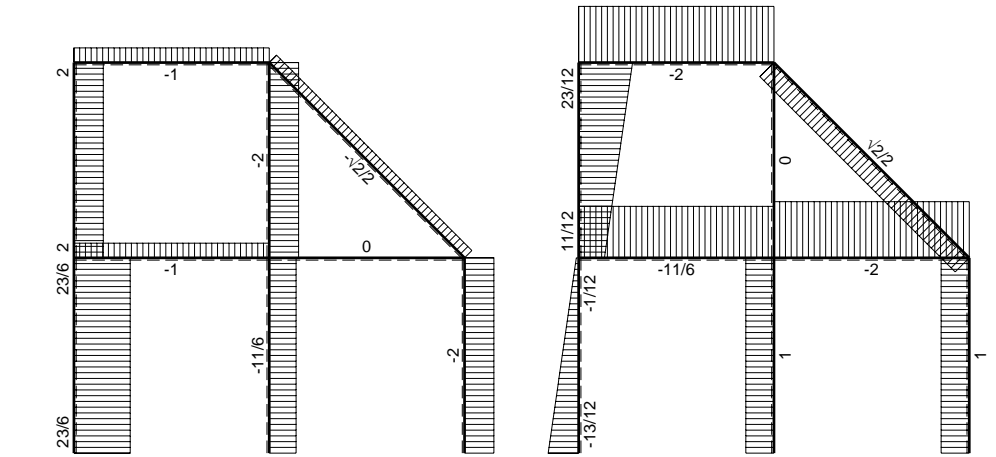
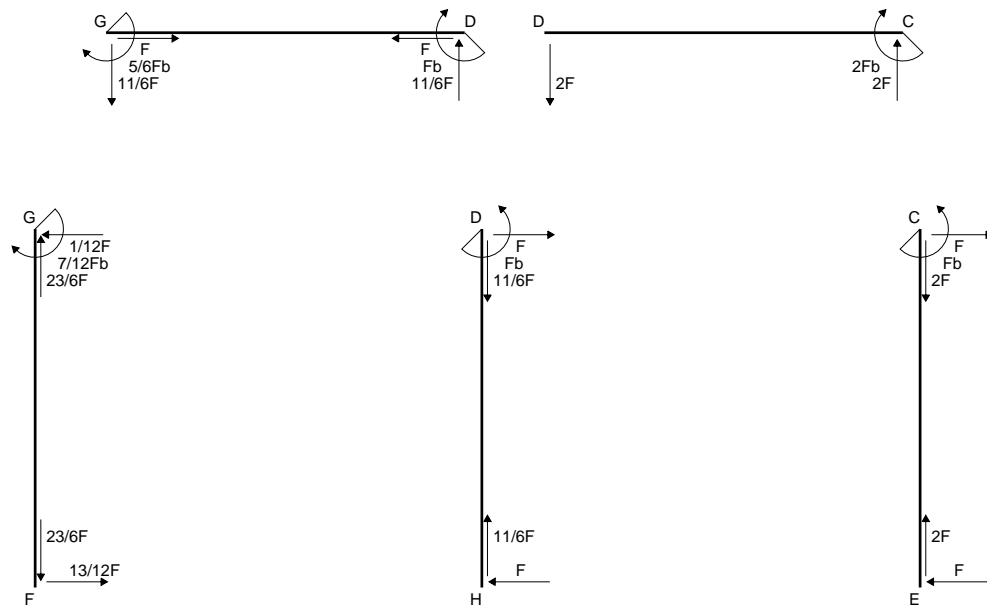
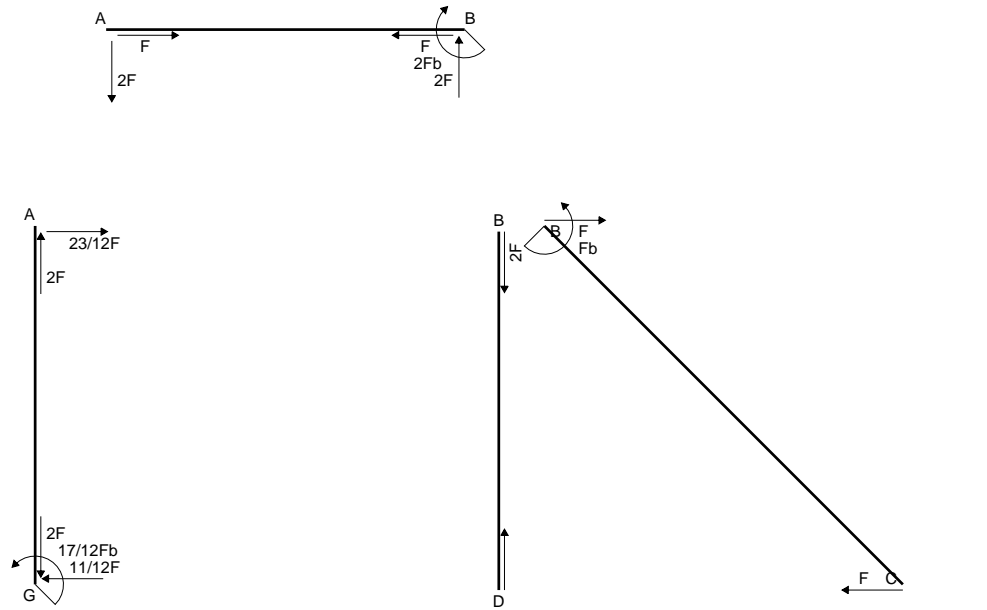

← ⊕ → F

↑ ⊕ ↓ F

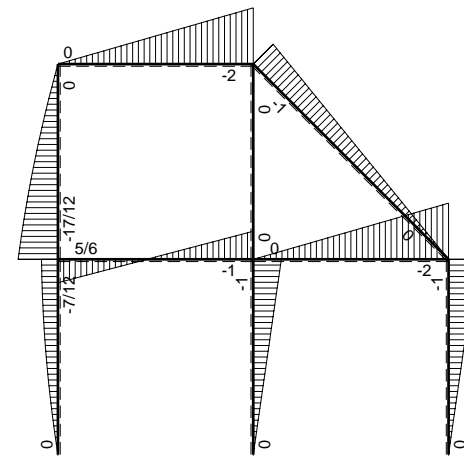

⊕ ⊖ Fb

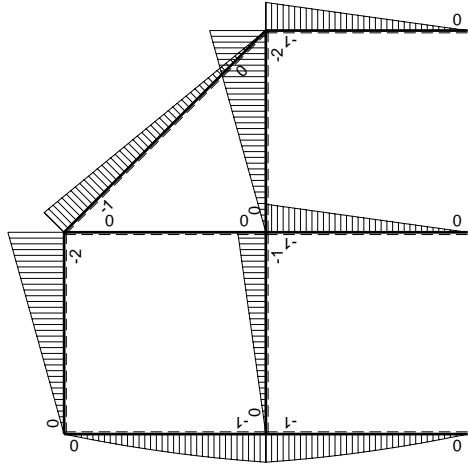
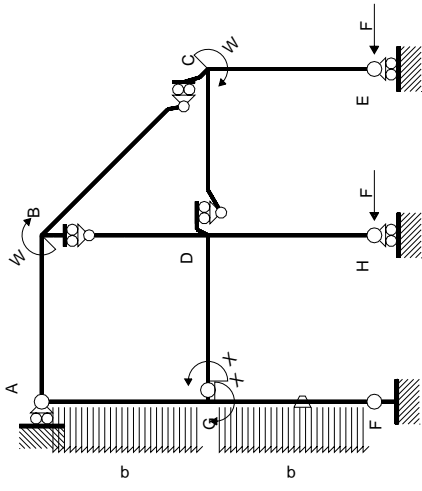

Schema di calcolo iperstatico

M_0 flessione da carichi assegnati

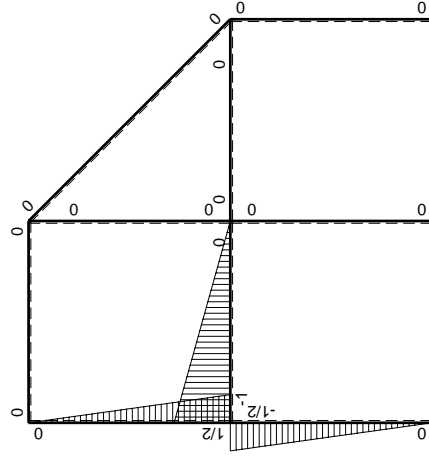

M_x flessione da iperstatica $X=1$

Quadro contributi PLV per iperstatica $X=W_{GD}$

→	$M_x(x)$	$M_o(x)$	θ	$M_x M_o$	$M_x \theta$	$M_x M_x$	$\int M_x(M_o/EJ+\theta)dx$	$\int X M_x M_x / EJ dx$
AB b	0	-2Fx	0	0	0	0	0+0	0
BA b	0	2Fb-2Fx	0	0	0	0		
BC $\sqrt{2}b$	0	-Fb+ $\sqrt{2}/2Fx$	0	0	0	0	0	0
BD b	0	0	0	0	0	0	0+0	0
DB b	0	0	0	0	0	0		
DC b	0	-2Fx	0	0	0	0	0+0	0
CD b	0	2Fb-2Fx	0	0	0	0		
CE b	0	-Fb+Fx	0	0	0	0	0+0	0
EC b	0	Fx	0	0	0	0		
FG b	-1/2x/b	-3/2Fx+1/2qx ²	-Fb/EJ	3/4Fx ² /b-1/4qx ³ /b	1/2Fx/EJ	1/4x ² /b ²	(3/16+1/4)Fb ² /EJ	1/12Xb/EJ
GF b	1/2-1/2x/b	Fb-1/2Fx-1/2qx ²	Fb/EJ	1/2Fb-3/4Fx+1/4qx ³ /b	1/2Fb/EJ-1/2Fx/EJ	1/4-1/2x/b+1/4x ² /b ²		
GD b	-1+x/b	-Fx	0	Fx-Fx ² /b	0	1-2x/b+x ² /b ²	(1/6+0)Fb ² /EJ	1/3Xb/EJ
DG b	x/b	Fb-Fx	0	Fx-Fx ² /b	0	x ² /b ²		
DH b	0	-Fb+Fx	0	0	0	0	0+0	0
HD b	0	Fx	0	0	0	0		
GA b	1/2-1/2x/b	-Fb+1/2Fx+1/2qx ²	0	-1/2Fb+3/4Fx-1/4qx ³ /b	0	1/4-1/2x/b+1/4x ² /b ²	(-3/16+0)Fb ² /EJ	1/12Xb/EJ
AG b	-1/2x/b	3/2Fx-1/2qx ²	0	-3/4Fx ² /b+1/4qx ³ /b	0	1/4x ² /b ²		
	totali						5/12Fb ² /EJ	1/2Xb/EJ
	iperstatica $X=W_{GD}$						-5/6Fb	

Sviluppi di calcolo iperstatica

$$L_{FG}^{xx} = \int_0^b (1/4 x^2/b^2) 1/EJ dx = [1/12 x^3/b^2]_0^b 1/EJ$$

$$= (1/12 b) 1/EJ = 1/12 b/EJ$$

$$L_{GF}^{xx} = \int_0^b (1/4 - 1/2 x/b + 1/4 x^2/b^2) 1/EJ dx = [1/4 x - 1/4 x^2/b + 1/12 x^3/b^2]_0^b 1/EJ$$

$$= (1/4 b - 1/4 b + 1/12 b) 1/EJ = 1/12 b/EJ$$

$$L_{GD}^{xx} = \int_0^b (1 - 2 x/b + x^2/b^2) 1/EJ dx = [x - x^2/b + 1/3 x^3/b^2]_0^b 1/EJ$$

$$= (b - b + 1/3 b) 1/EJ = 1/3 b/EJ$$

$$L_{DG}^{xx} = \int_0^b (x^2/b^2) 1/EJ dx = [1/3 x^3/b^2]_0^b 1/EJ$$

$$= (1/3 b) 1/EJ = 1/3 b/EJ$$

$$L_{GA}^{xx} = \int_0^b (1/4 - 1/2 x/b + 1/4 x^2/b^2) 1/EJ dx = [1/4 x - 1/4 x^2/b + 1/12 x^3/b^2]_0^b 1/EJ$$

$$= (1/4 b - 1/4 b + 1/12 b) 1/EJ = 1/12 b/EJ$$

$$L_{AG}^{xx} = \int_0^b (1/4 x^2/b^2) 1/EJ dx = [1/12 x^3/b^2]_0^b 1/EJ$$

$$= (1/12 b) 1/EJ = 1/12 b/EJ$$

$$L_{FG}^{xo} = \int_0^b (3/4 x^2/b^2 - 1/4 x^3/b^3) Fb 1/EJ dx + \int_0^b (1/2 x/b) \theta dx$$

$$= [1/4 x^3/b^2 - 1/16 x^4/b^3]_0^b Fb 1/EJ + [1/4 x^2/b]_0^b \theta$$

$$= (1/4 b - 1/16 b) Fb 1/EJ + (1/4 b) \theta = 7/16 Fb^2/EJ$$

$$L_{GF}^{xo} = \int_0^b (1/2 - 3/4 x/b + 1/4 x^2/b^2) Fb 1/EJ dx + \int_0^b (-1/2 + 1/2 x/b) \theta dx$$

$$= [1/2 x - 3/8 x^2/b + 1/16 x^3/b^2]_0^b Fb 1/EJ + [-1/2 x + 1/4 x^2/b]_0^b \theta$$

$$= (1/2 b - 3/8 b + 1/16 b) Fb 1/EJ + (-1/2 b + 1/4 b) \theta = 7/16 Fb^2/EJ$$

$$L_{GD}^{xo} = \int_0^b (x/b - x^2/b^2) Fb 1/EJ dx = [1/2 x^2/b - 1/3 x^3/b^2]_0^b Fb 1/EJ$$

$$= (1/2 b - 1/3 b) Fb 1/EJ = 1/6 Fb^2/EJ$$

$$L_{DG}^{xo} = \int_0^b (x/b - x^2/b^2) Fb 1/EJ dx = [1/2 x^2/b - 1/3 x^3/b^2]_0^b Fb 1/EJ$$

$$= (1/2 b - 1/3 b) Fb 1/EJ = 1/6 Fb^2/EJ$$

$$L_{GA}^{xo} = \int_0^b (-1/2 + 3/4 x/b - 1/4 x^2/b^2) Fb 1/EJ dx = [-1/2 x + 3/8 x^2/b - 1/16 x^3/b^2]_0^b Fb 1/EJ$$

$$= (-1/2 b + 3/8 b - 1/16 b) Fb 1/EJ = -3/16 Fb^2/EJ$$

$$L_{AG}^{xo} = \int_0^b (-3/4 x^2/b^2 + 1/4 x^3/b^3) Fb 1/EJ dx = [-1/4 x^3/b^2 + 1/16 x^4/b^3]_0^b Fb 1/EJ$$

$$= (-1/4 b + 1/16 b) Fb 1/EJ = -3/16 Fb^2/EJ$$

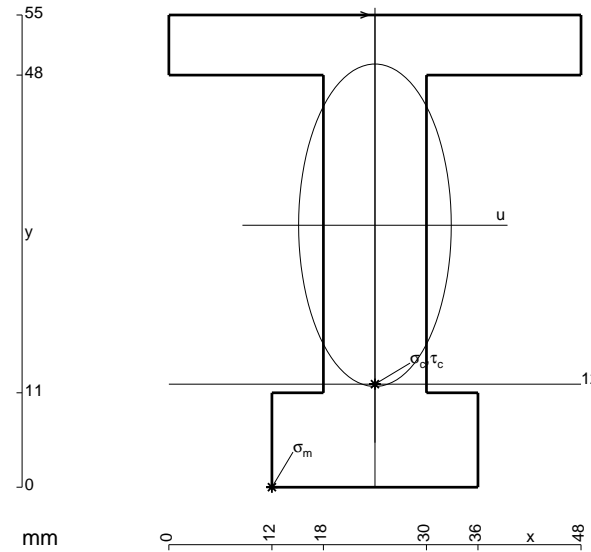

- A = 1044. mm²
- J_u = 368307. mm⁴
- J_v = 82512. mm⁴
- y_g = 30.51 mm
- N = -2050. N
- T_y = -4100. N
- M_x = -2747000. Nmm
- x_m = 12. mm
- u_m = -12. mm
- v_m = -30.51 mm
- σ_m = N/A-Mv/J_u = -229.5 N/mm²
- x_c = 24. mm
- y_c = 12. mm
- v_c = -18.51 mm
- σ_c = N/A-Mv/J_u = -140. N/mm²
- τ_c = 6.337 N/mm²
- σ_o = √σ²+3τ² = 140.5 N/mm²
- S = 6831. mm³

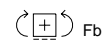
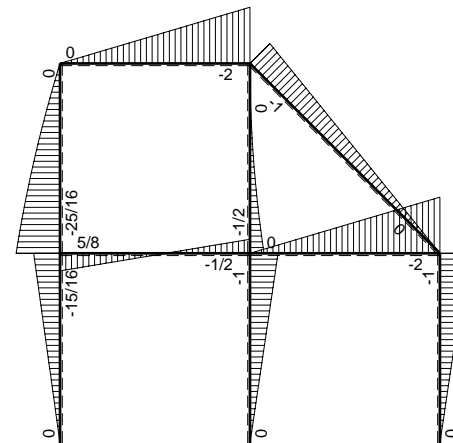
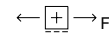
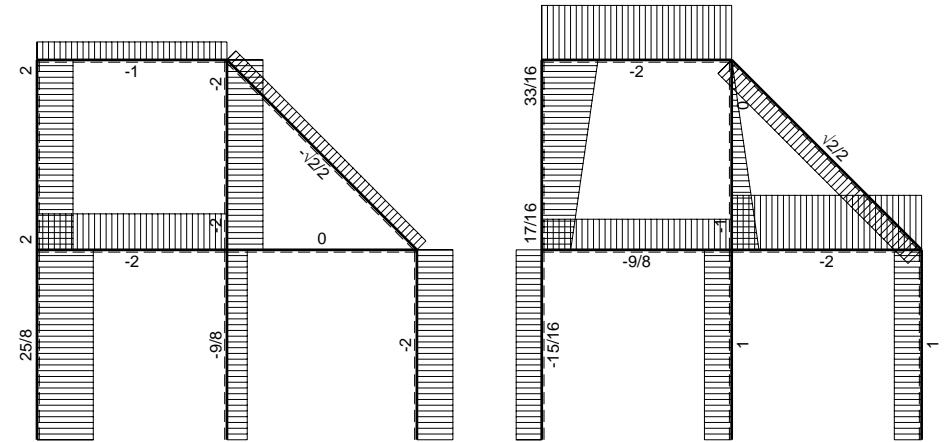
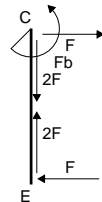
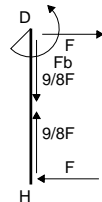
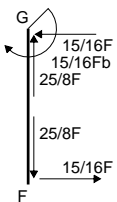
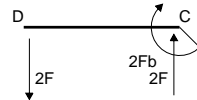
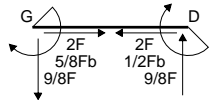
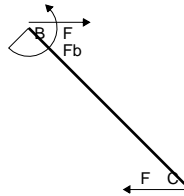
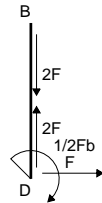
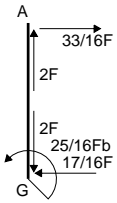
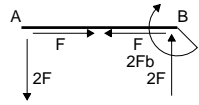

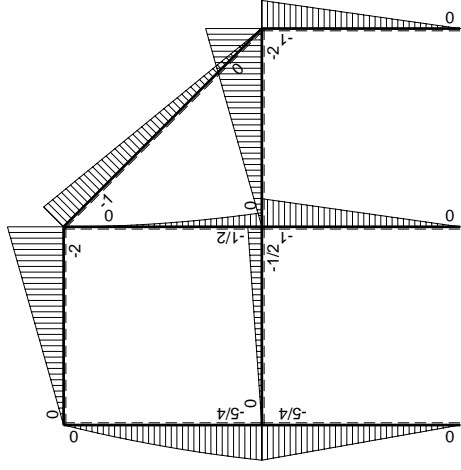
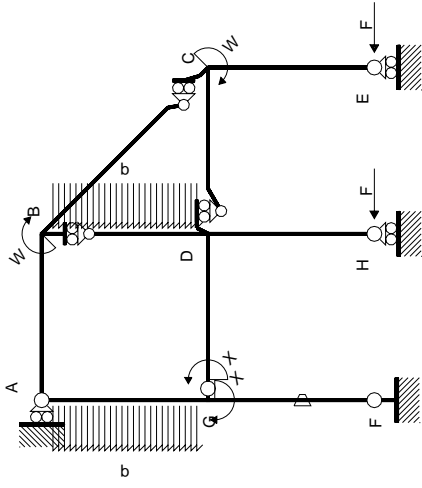

Schema di calcolo iperstatico

M_0 flessione da carichi assegnati

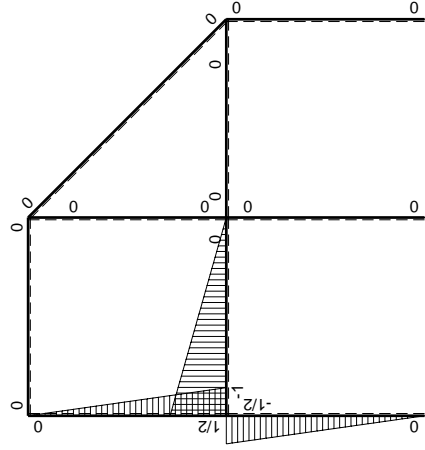

M_x flessione da iperstatica $X=1$

Quadro contributi PLV per iperstatica $X=W_{GD}$

→	$M_x(x)$	$M_o(x)$	θ	$M_x M_o$	$M_x \theta$	$M_x M_x$	$\int M_x(M_o/EJ+\theta)dx$	$\int X M_x M_x/EJ dx$	
AB b	0	-2Fx	0	0	0	0	0+0	0	
BA b	0	2Fb-2Fx	0	0	0	0	0	0	
BC $\sqrt{2}b$	0	-Fb+ $\sqrt{2}/2Fx$	0	0	0	0	0	0	
BD b	0	-1/2qx ²	0	0	0	0	0+0	0	
DB b	0	1/2Fb-Fx+1/2qx ²	0	0	0	0	0	0	
DC b	0	-2Fx	0	0	0	0	0+0	0	
CD b	0	2Fb-2Fx	0	0	0	0	0	0	
CE b	0	-Fb+Fx	0	0	0	0	0+0	0	
EC b	0	Fx	0	0	0	0	0	0	
FG b	-1/2x/b	-5/4Fx	-Fb/EJ	5/8Fx ² /b	1/2Fx/EJ	1/4x ² /b ²	(5/24+1/4)Fb ² /EJ	1/12Xb/EJ	
GF b	1/2-1/2x/b	5/4Fb-5/4Fx	Fb/EJ	5/8Fb-5/4Fx+5/8Fx ² /b	1/2Fb/EJ-1/2Fx/EJ	1/4-1/2x/b+1/4x ² /b ²			
GD b	-1+x/b	-1/2Fx	0	1/2Fx-1/2Fx ² /b	0	1-2x/b+x ² /b ²	(1/12+0)Fb ² /EJ	1/3Xb/EJ	
DG b	x/b	1/2Fb-1/2Fx	0	1/2Fx-1/2Fx ² /b	0	x ² /b ²			
DH b	0	-Fb+Fx	0	0	0	0	0+0	0	
HD b	0	Fx	0	0	0	0	0	0	
GA b	1/2-1/2x/b	-5/4Fb+3/4Fx+1/2qx ²	0	-5/8Fb+Fx-1/8Fx ² /b-1/4qx ³ /b	0	1/4-1/2x/b+1/4x ² /b ²	(-11/48+0)Fb ² /EJ	1/12Xb/EJ	
AG b	-1/2x/b	7/4Fx-1/2qx ²	0	-7/8Fx ² /b+1/4qx ³ /b	0	1/4x ² /b ²			
	totali							5/16Fb ² /EJ	1/2Xb/EJ
	iperstatica $X=W_{GD}$							-5/8Fb	

Sviluppi di calcolo iperstatica

$$L_{FG}^{xx} = \int_0^b (1/4 x^2/b^2) 1/EJ dx = [1/12 x^3/b^2]_0^b 1/EJ$$

$$= (1/12 b) 1/EJ = 1/12 b/EJ$$

$$L_{GF}^{xx} = \int_0^b (1/4 -1/2 x/b +1/4 x^2/b^2) 1/EJ dx = [1/4 x -1/4 x^2/b +1/12 x^3/b^2]_0^b 1/EJ$$

$$= (1/4 b -1/4 b +1/12 b) 1/EJ = 1/12 b/EJ$$

$$L_{GD}^{xx} = \int_0^b (1 -2 x/b + x^2/b^2) 1/EJ dx = [x - x^2/b +1/3 x^3/b^2]_0^b 1/EJ$$

$$= (b - b +1/3 b) 1/EJ = 1/3 b/EJ$$

$$L_{DG}^{xx} = \int_0^b (x^2/b^2) 1/EJ dx = [1/3 x^3/b^2]_0^b 1/EJ$$

$$= (1/3 b) 1/EJ = 1/3 b/EJ$$

$$L_{GA}^{xx} = \int_0^b (1/4 -1/2 x/b +1/4 x^2/b^2) 1/EJ dx = [1/4 x -1/4 x^2/b +1/12 x^3/b^2]_0^b 1/EJ$$

$$= (1/4 b -1/4 b +1/12 b) 1/EJ = 1/12 b/EJ$$

$$L_{AG}^{xx} = \int_0^b (1/4 x^2/b^2) 1/EJ dx = [1/12 x^3/b^2]_0^b 1/EJ$$

$$= (1/12 b) 1/EJ = 1/12 b/EJ$$

$$L_{FG}^{xo} = \int_0^b (5/8 x^2/b^2) Fb 1/EJ dx + \int_0^b (1/2 x/b) \theta dx = [5/24 x^3/b^2]_0^b Fb 1/EJ + [1/4 x^2/b]_0^b \theta$$

$$= (5/24 b) Fb 1/EJ + (1/4 b) \theta = 11/24 Fb^2/EJ$$

$$L_{GF}^{xo} = \int_0^b (5/8 -5/4 x/b +5/8 x^2/b^2) Fb 1/EJ dx + \int_0^b (-1/2 +1/2 x/b) \theta dx$$

$$= [5/8 x -5/8 x^2/b +5/24 x^3/b^2]_0^b Fb 1/EJ + [-1/2 x +1/4 x^2/b]_0^b \theta$$

$$= (5/8 b -5/8 b +5/24 b) Fb 1/EJ + (-1/2 b +1/4 b) \theta = 11/24 Fb^2/EJ$$

$$L_{GD}^{xo} = \int_0^b (1/2 x/b -1/2 x^2/b^2) Fb 1/EJ dx = [1/4 x^2/b -1/6 x^3/b^2]_0^b Fb 1/EJ$$

$$= (1/4 b -1/6 b) Fb 1/EJ = 1/12 Fb^2/EJ$$

$$L_{DG}^{xo} = \int_0^b (1/2 x/b -1/2 x^2/b^2) Fb 1/EJ dx = [1/4 x^2/b -1/6 x^3/b^2]_0^b Fb 1/EJ$$

$$= (1/4 b -1/6 b) Fb 1/EJ = 1/12 Fb^2/EJ$$

$$L_{GA}^{xo} = \int_0^b (-5/8 + x/b -1/8 x^2/b^2 -1/4 x^3/b^3) Fb 1/EJ dx$$

$$= [-5/8 x +1/2 x^2/b -1/24 x^3/b^2 -1/16 x^4/b^3]_0^b Fb 1/EJ$$

$$= (-5/8 b +1/2 b -1/24 b -1/16 b) Fb 1/EJ = -11/48 Fb^2/EJ$$

$$L_{AG}^{xo} = \int_0^b (-7/8 x^2/b^2 +1/4 x^3/b^3) Fb 1/EJ dx = [-7/24 x^3/b^2 +1/16 x^4/b^3]_0^b Fb 1/EJ$$

$$= (-7/24 b +1/16 b) Fb 1/EJ = -11/48 Fb^2/EJ$$

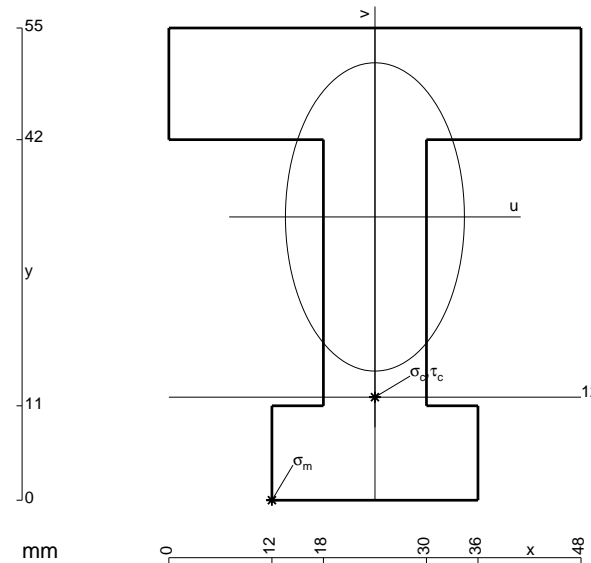

- A = 1260. mm²
- J_u = 406524. mm⁴
- J_v = 136944. mm⁴
- y_g = 33. mm
- N = -2030. N
- T_y = -4060. N
- M_x = -2923200. Nmm
- x_m = 12. mm
- u_m = -12. mm
- v_m = -33. mm
- σ_m = N/A-Mv/J_u = -238.9 N/mm²
- x_c = 24. mm
- y_c = 12. mm
- v_c = -21. mm
- σ_c = N/A-Mv/J_u = -152.6 N/mm²
- τ_c = 6.256 N/mm²
- σ_o = √σ²+3τ² = 153. N/mm²
- S = 7517. mm³

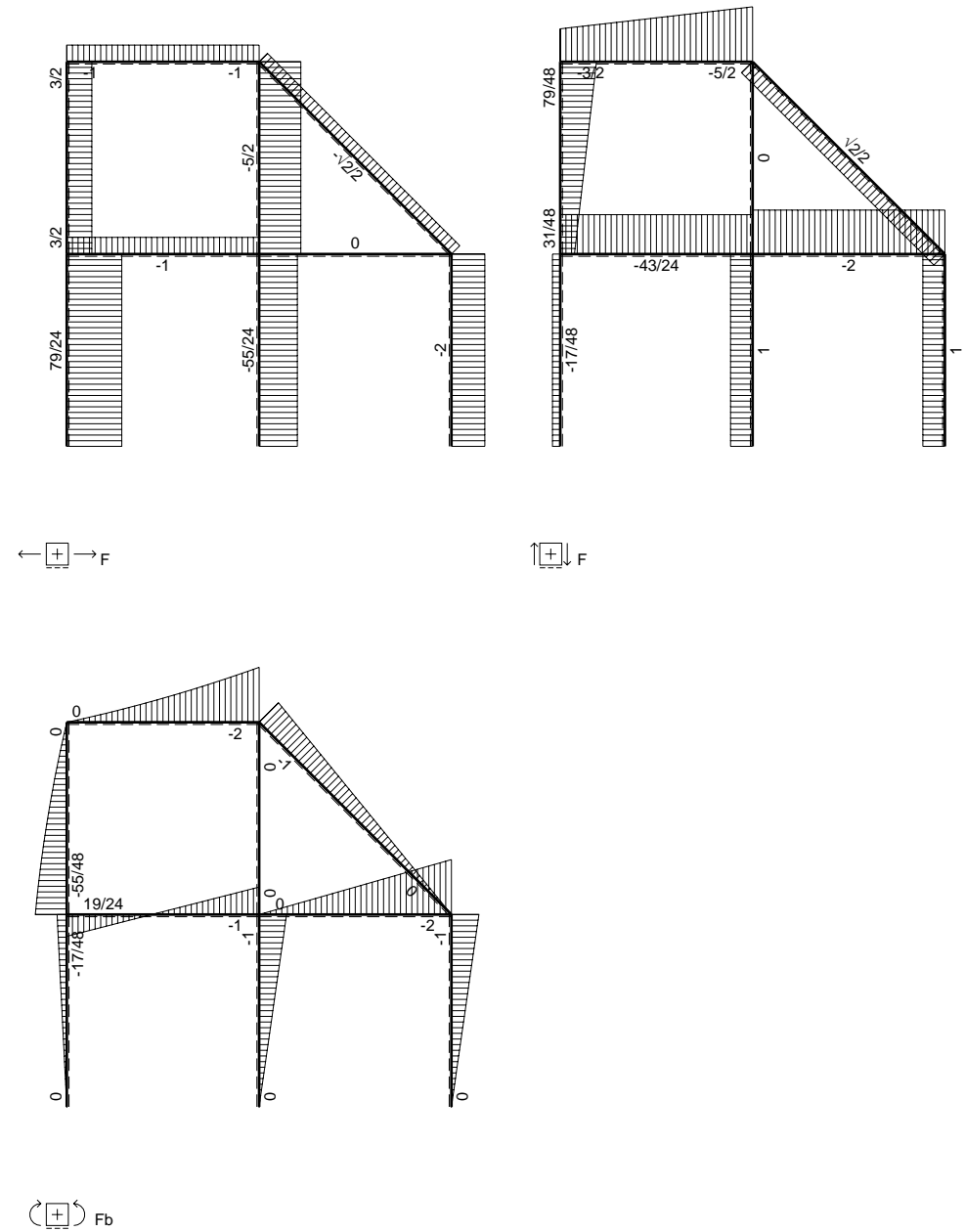
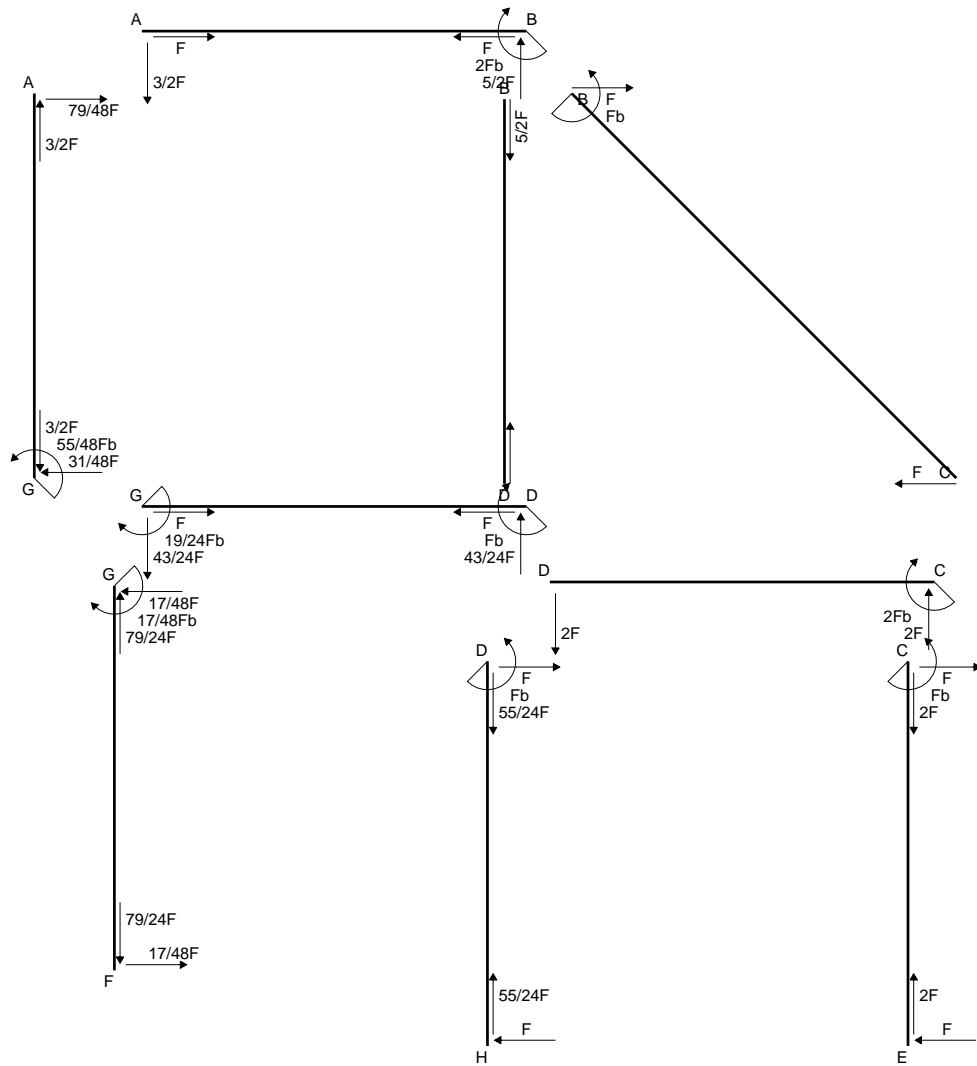

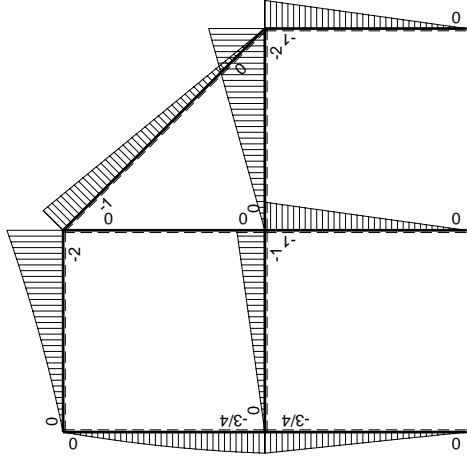
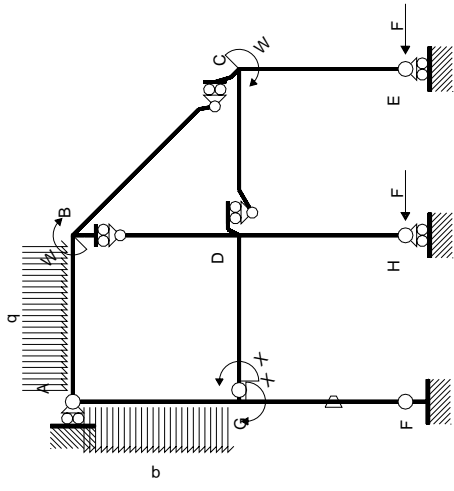

Schema di calcolo iperstatico

M_0 flessione da carichi assegnati

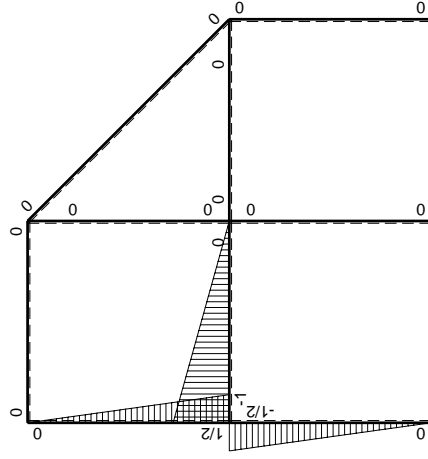

M_x flessione da iperstatica $X=1$

Quadro contributi PLV per iperstatica $X=W_{GD}$

→	$M_x(x)$	$M_o(x)$	θ	$M_x M_o$	$M_x \theta$	$M_x M_x$	$\int M_x(M_o/EJ+\theta)dx$	$\int X M_x M_x/EJ dx$
AB b	0	$-3/2Fx-1/2qx^2$	0	0	0	0	0+0	0
BA b	0	$2Fb-5/2Fx+1/2qx^2$	0	0	0	0	0	0
BC $\sqrt{2}b$	0	$-Fb+\sqrt{2}/2Fx$	0	0	0	0	0	0
BD b	0	0	0	0	0	0	0+0	0
DB b	0	0	0	0	0	0	0	0
DC b	0	$-2Fx$	0	0	0	0	0+0	0
CD b	0	$2Fb-2Fx$	0	0	0	0	0	0
CE b	0	$-Fb+Fx$	0	0	0	0	0+0	0
EC b	0	Fx	0	0	0	0	0	0
FG b	$-1/2x/b$	$-3/4Fx$	$-Fb/EJ$	$3/8Fx^2/b$	$1/2Fx/EJ$	$1/4x^2/b^2$	$(1/8+1/4)Fb^2/EJ$	$1/12Xb/EJ$
GF b	$1/2-1/2x/b$	$3/4Fb-3/4Fx$	Fb/EJ	$3/8Fb-3/4Fx+3/8Fx^2/b$	$1/2Fb/EJ-1/2Fx/EJ$	$1/4-1/2x/b+1/4x^2/b^2$		
GD b	$-1+x/b$	$-Fx$	0	$Fx-Fx^2/b$	0	$1-2x/b+x^2/b^2$	$(1/6+0)Fb^2/EJ$	$1/3Xb/EJ$
DG b	x/b	$Fb-Fx$	0	$Fx-Fx^2/b$	0	x^2/b^2		
DH b	0	$-Fb+Fx$	0	0	0	0	0+0	0
HD b	0	Fx	0	0	0	0		
GA b	$1/2-1/2x/b$	$-3/4Fb+1/4Fx+1/2qx^2$	0	$-3/8Fb+1/2Fx+1/8Fx^2/b-1/4qx^3/b$	0	$1/4-1/2x/b+1/4x^2/b^2$	$(-7/48+0)Fb^2/EJ$	$1/12Xb/EJ$
AG b	$-1/2x/b$	$5/4Fx-1/2qx^2$	0	$-5/8Fx^2/b+1/4qx^3/b$	0	$1/4x^2/b^2$		
	totali						$19/48Fb^2/EJ$	$1/2Xb/EJ$
	iperstatica $X=W_{GD}$						$-19/24Fb$	

Sviluppi di calcolo iperstatica

$$L_{FG}^{xx} = \int_0^b (1/4 x^2/b^2) 1/EJ dx = [1/12 x^3/b^2]_0^b 1/EJ$$

$$= (1/12 b) 1/EJ = 1/12 b/EJ$$

$$L_{GF}^{xx} = \int_0^b (1/4 - 1/2 x/b + 1/4 x^2/b^2) 1/EJ dx = [1/4 x - 1/4 x^2/b + 1/12 x^3/b^2]_0^b 1/EJ$$

$$= (1/4 b - 1/4 b + 1/12 b) 1/EJ = 1/12 b/EJ$$

$$L_{GD}^{xx} = \int_0^b (1 - 2 x/b + x^2/b^2) 1/EJ dx = [x - x^2/b + 1/3 x^3/b^2]_0^b 1/EJ$$

$$= (b - b + 1/3 b) 1/EJ = 1/3 b/EJ$$

$$L_{DG}^{xx} = \int_0^b (x^2/b^2) 1/EJ dx = [1/3 x^3/b^2]_0^b 1/EJ$$

$$= (1/3 b) 1/EJ = 1/3 b/EJ$$

$$L_{GA}^{xx} = \int_0^b (1/4 - 1/2 x/b + 1/4 x^2/b^2) 1/EJ dx = [1/4 x - 1/4 x^2/b + 1/12 x^3/b^2]_0^b 1/EJ$$

$$= (1/4 b - 1/4 b + 1/12 b) 1/EJ = 1/12 b/EJ$$

$$L_{AG}^{xx} = \int_0^b (1/4 x^2/b^2) 1/EJ dx = [1/12 x^3/b^2]_0^b 1/EJ$$

$$= (1/12 b) 1/EJ = 1/12 b/EJ$$

$$L_{FG}^{xo} = \int_0^b (3/8 x^2/b^2) Fb 1/EJ dx + \int_0^b (1/2 x/b) \theta dx = [1/8 x^3/b^2]_0^b Fb 1/EJ + [1/4 x^2/b]_0^b \theta$$

$$= (1/8 b) Fb 1/EJ + (1/4 b) \theta = 3/8 Fb^2/EJ$$

$$L_{GF}^{xo} = \int_0^b (3/8 - 3/4 x/b + 3/8 x^2/b^2) Fb 1/EJ dx + \int_0^b (-1/2 + 1/2 x/b) \theta dx$$

$$= [3/8 x - 3/8 x^2/b + 1/8 x^3/b^2]_0^b Fb 1/EJ + [-1/2 x + 1/4 x^2/b]_0^b \theta$$

$$= (3/8 b - 3/8 b + 1/8 b) Fb 1/EJ + (-1/2 b + 1/4 b) \theta = 3/8 Fb^2/EJ$$

$$L_{GD}^{xo} = \int_0^b (x/b - x^2/b^2) Fb 1/EJ dx = [1/2 x^2/b - 1/3 x^3/b^2]_0^b Fb 1/EJ$$

$$= (1/2 b - 1/3 b) Fb 1/EJ = 1/6 Fb^2/EJ$$

$$L_{DG}^{xo} = \int_0^b (x/b - x^2/b^2) Fb 1/EJ dx = [1/2 x^2/b - 1/3 x^3/b^2]_0^b Fb 1/EJ$$

$$= (1/2 b - 1/3 b) Fb 1/EJ = 1/6 Fb^2/EJ$$

$$L_{GA}^{xo} = \int_0^b (-3/8 + 1/2 x/b + 1/8 x^2/b^2 - 1/4 x^3/b^3) Fb 1/EJ dx$$

$$= [-3/8 x + 1/4 x^2/b + 1/24 x^3/b^2 - 1/16 x^4/b^3]_0^b Fb 1/EJ$$

$$= (-3/8 b + 1/4 b + 1/24 b - 1/16 b) Fb 1/EJ = -7/48 Fb^2/EJ$$

$$L_{AG}^{xo} = \int_0^b (-5/8 x^2/b^2 + 1/4 x^3/b^3) Fb 1/EJ dx = [-5/24 x^3/b^2 + 1/16 x^4/b^3]_0^b Fb 1/EJ$$

$$= (-5/24 b + 1/16 b) Fb 1/EJ = -7/48 Fb^2/EJ$$

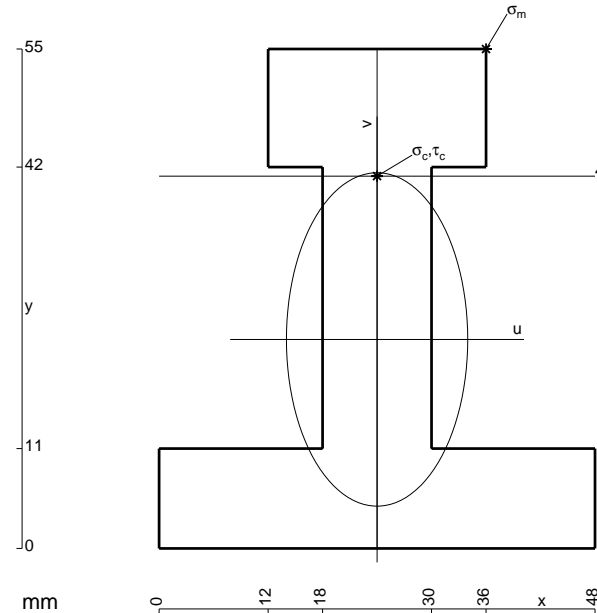

$$A = 1212. \text{ mm}^2$$

$$J_u = 408644. \text{ mm}^4$$

$$J_v = 120816. \text{ mm}^4$$

$$y_g = 23.01 \text{ mm}$$

$$N = -1640. \text{ N}$$

$$T_y = -4100. \text{ N}$$

$$M_x = -2558400. \text{ Nmm}$$

$$x_m = 36. \text{ mm}$$

$$y_m = 55. \text{ mm}$$

$$u_m = 12. \text{ mm}$$

$$v_m = 31.99 \text{ mm}$$

$$\sigma_m = N/A - Mv/J_u = 198.9 \text{ N/mm}^2$$

$$x_c = 24. \text{ mm}$$

$$y_c = 41. \text{ mm}$$

$$v_c = 17.99 \text{ mm}$$

$$\sigma_c = N/A - Mv/J_u = 111.2 \text{ N/mm}^2$$

$$\tau_c = 6.834 \text{ N/mm}^2$$

$$\sigma_o = \sqrt{\sigma^2 + 3\tau^2} = 111.9 \text{ N/mm}^2$$

$$S = 8173. \text{ mm}^3$$

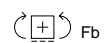
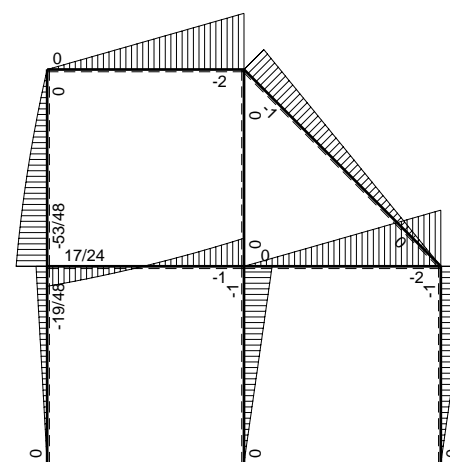
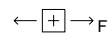
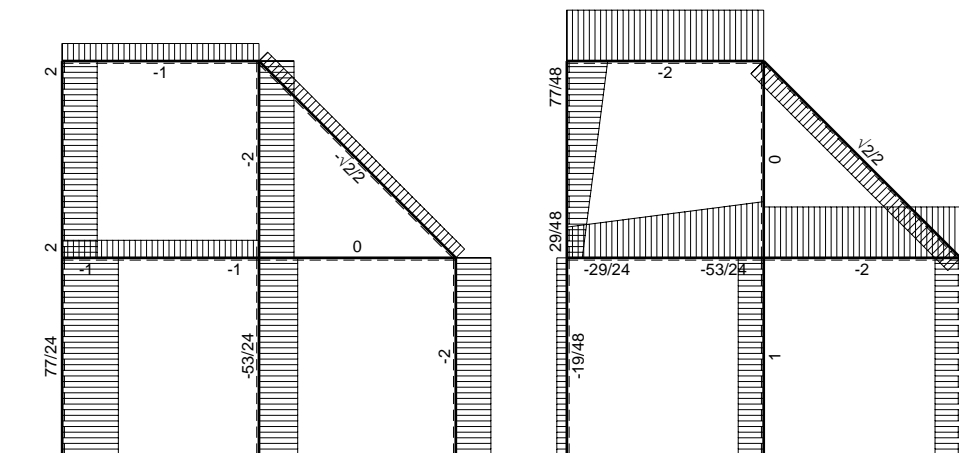
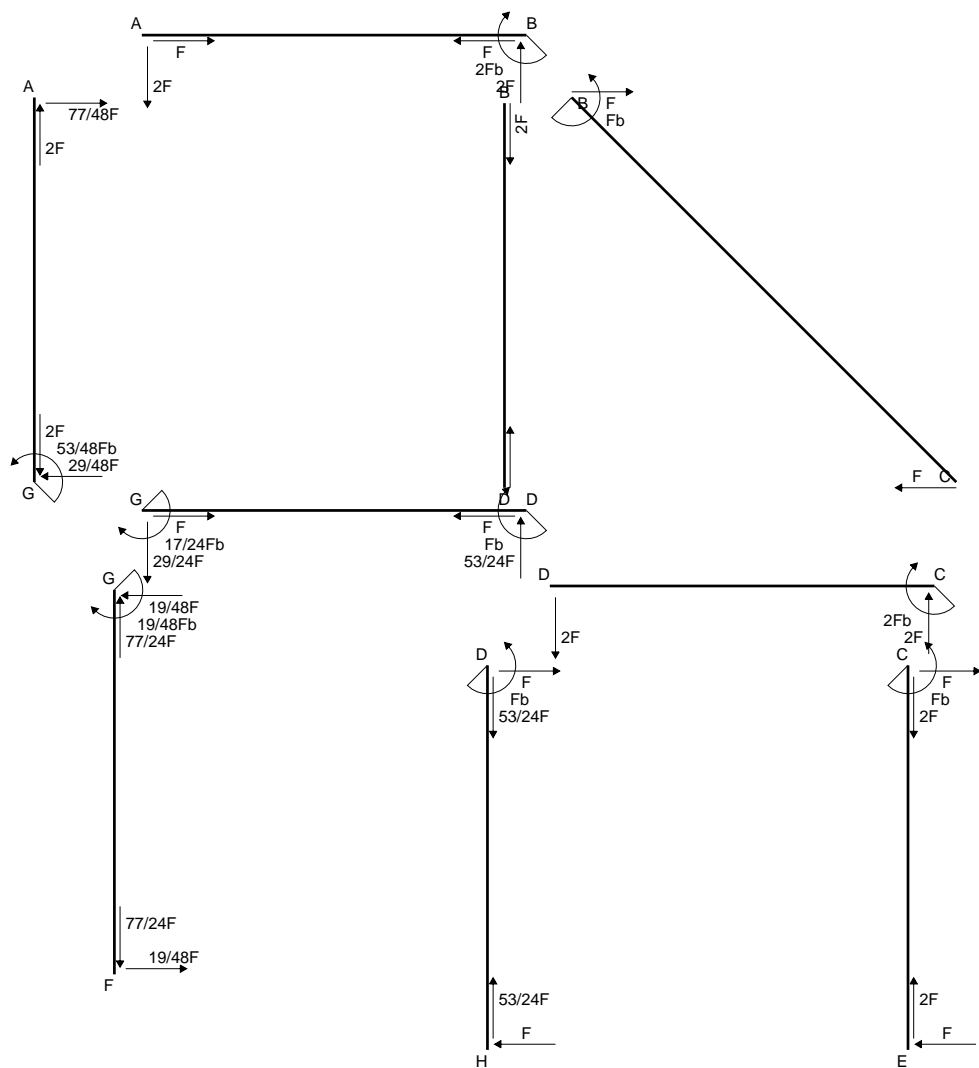

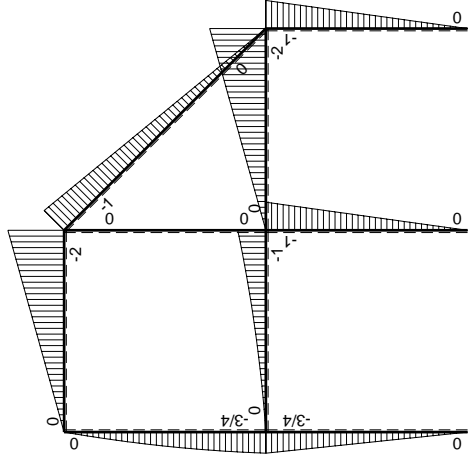
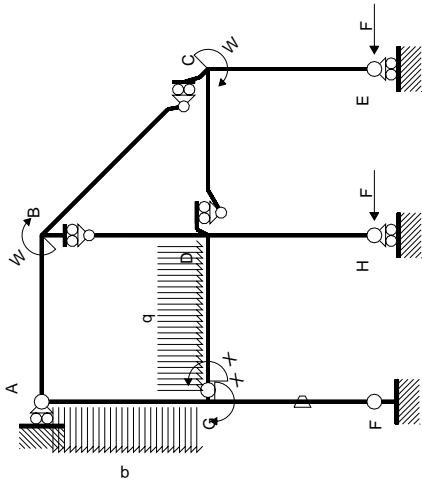

Schema di calcolo iperstatico

M_0 flessione da carichi assegnati

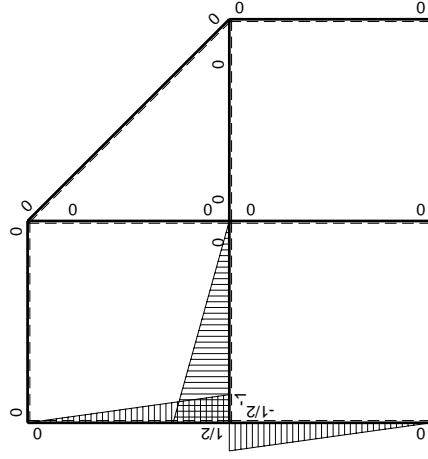

M_1 flessione da iperstatica $X=1$

Quadro contributi PLV per iperstatica $X=W_{GD}$

→	$M_x(x)$	$M_o(x)$	θ	$M_x M_o$	$M_x \theta$	$M_x M_x$	$\int M_x(M_o/EJ+\theta)dx$	$\int X M_x M_x/EJ dx$
AB b	0	-2Fx	0	0	0	0	0+0	0
BA b	0	2Fb-2Fx	0	0	0	0	0	0
BC $\sqrt{2}b$	0	-Fb+ $\sqrt{2}/2Fx$	0	0	0	0	0	0
BD b	0	0	0	0	0	0	0+0	0
DB b	0	0	0	0	0	0	0	0
DC b	0	-2Fx	0	0	0	0	0+0	0
CD b	0	2Fb-2Fx	0	0	0	0	0	0
CE b	0	-Fb+Fx	0	0	0	0	0+0	0
EC b	0	Fx	0	0	0	0	0	0
FG b	-1/2x/b	-3/4Fx	-Fb/EJ	$3/8Fx^2/b$	$1/2Fx/EJ$	$1/4x^2/b^2$	$(1/8+1/4)Fb^2/EJ$	$1/12Xb/EJ$
GF b	$1/2-1/2x/b$	$3/4Fb-3/4Fx$	Fb/EJ	$3/8Fb-3/4Fx+3/8Fx^2/b$	$1/2Fb/EJ-1/2Fx/EJ$	$1/4-1/2x/b+1/4x^2/b^2$		
GD b	-1+x/b	-1/2Fx-1/2qx ²	0	$1/2Fx-1/2qx^3/b$	0	$1-2x/b+x^2/b^2$	$(1/8+0)Fb^2/EJ$	$1/3Xb/EJ$
DG b	x/b	$Fb-3/2Fx+1/2qx^2$	0	$Fx-3/2Fx^2/b+1/2qx^3/b$	0	x^2/b^2		
DH b	0	-Fb+Fx	0	0	0	0	0+0	0
HD b	0	Fx	0	0	0	0	0	0
GA b	$1/2-1/2x/b$	$-3/4Fb+1/4Fx+1/2qx^2$	0	$-3/8Fb+1/2Fx+1/8Fx^2/b-1/4qx^3/b$	0	$1/4-1/2x/b+1/4x^2/b^2$	$(-7/48+0)Fb^2/EJ$	$1/12Xb/EJ$
AG b	-1/2x/b	$5/4Fx-1/2qx^2$	0	$-5/8Fx^2/b+1/4qx^3/b$	0	$1/4x^2/b^2$		
	totali						$17/48Fb^2/EJ$	$1/2Xb/EJ$
	iperstatica $X=W_{GD}$						-17/24Fb	

Sviluppi di calcolo iperstatica

$$L_{FG}^{xx} = \int_0^b (1/4 x^2/b^2) 1/EJ dx = [1/12 x^3/b^2]_0^b 1/EJ$$

$$= (1/12 b) 1/EJ = 1/12 b/EJ$$

$$L_{GF}^{xx} = \int_0^b (1/4 -1/2 x/b +1/4 x^2/b^2) 1/EJ dx = [1/4 x -1/4 x^2/b +1/12 x^3/b^2]_0^b 1/EJ$$

$$= (1/4 b -1/4 b +1/12 b) 1/EJ = 1/12 b/EJ$$

$$L_{GD}^{xx} = \int_0^b (1 -2 x/b + x^2/b^2) 1/EJ dx = [x - x^2/b +1/3 x^3/b^2]_0^b 1/EJ$$

$$= (b - b +1/3 b) 1/EJ = 1/3 b/EJ$$

$$L_{DG}^{xx} = \int_0^b (x^2/b^2) 1/EJ dx = [1/3 x^3/b^2]_0^b 1/EJ$$

$$= (1/3 b) 1/EJ = 1/3 b/EJ$$

$$L_{GA}^{xx} = \int_0^b (1/4 -1/2 x/b +1/4 x^2/b^2) 1/EJ dx = [1/4 x -1/4 x^2/b +1/12 x^3/b^2]_0^b 1/EJ$$

$$= (1/4 b -1/4 b +1/12 b) 1/EJ = 1/12 b/EJ$$

$$L_{AG}^{xx} = \int_0^b (1/4 x^2/b^2) 1/EJ dx = [1/12 x^3/b^2]_0^b 1/EJ$$

$$= (1/12 b) 1/EJ = 1/12 b/EJ$$

$$L_{FG}^{xo} = \int_0^b (3/8 x^2/b^2) Fb 1/EJ dx + \int_0^b (1/2 x/b) \theta dx = [1/8 x^3/b^2]_0^b Fb 1/EJ + [1/4 x^2/b]_0^b \theta$$

$$= (1/8 b) Fb 1/EJ + (1/4 b) \theta = 3/8 Fb^2/EJ$$

$$L_{GF}^{xo} = \int_0^b (3/8 -3/4 x/b +3/8 x^2/b^2) Fb 1/EJ dx + \int_0^b (-1/2 +1/2 x/b) \theta dx$$

$$= [3/8 x -3/8 x^2/b +1/8 x^3/b^2]_0^b Fb 1/EJ + [-1/2 x +1/4 x^2/b]_0^b \theta$$

$$= (3/8 b -3/8 b +1/8 b) Fb 1/EJ + (-1/2 b +1/4 b) \theta = 3/8 Fb^2/EJ$$

$$L_{GD}^{xo} = \int_0^b (1/2 x/b -1/2 x^3/b^3) Fb 1/EJ dx = [1/4 x^2/b -1/8 x^4/b^3]_0^b Fb 1/EJ$$

$$= (1/4 b -1/8 b) Fb 1/EJ = 1/8 Fb^2/EJ$$

$$L_{DG}^{xo} = \int_0^b (x/b -3/2 x^2/b^2 +1/2 x^3/b^3) Fb 1/EJ dx = [1/2 x^2/b -1/2 x^3/b^2 +1/8 x^4/b^3]_0^b Fb 1/EJ$$

$$= (1/2 b -1/2 b +1/8 b) Fb 1/EJ = 1/8 Fb^2/EJ$$

$$L_{GA}^{xo} = \int_0^b (-3/8 +1/2 x/b +1/8 x^2/b^2 -1/4 x^3/b^3) Fb 1/EJ dx$$

$$= [-3/8 x +1/4 x^2/b +1/24 x^3/b^2 -1/16 x^4/b^3]_0^b Fb 1/EJ$$

$$= (-3/8 b +1/4 b +1/24 b -1/16 b) Fb 1/EJ = -7/48 Fb^2/EJ$$

$$L_{AG}^{xo} = \int_0^b (-5/8 x^2/b^2 +1/4 x^3/b^3) Fb 1/EJ dx = [-5/24 x^3/b^2 +1/16 x^4/b^3]_0^b Fb 1/EJ$$

$$= (-5/24 b +1/16 b) Fb 1/EJ = -7/48 Fb^2/EJ$$

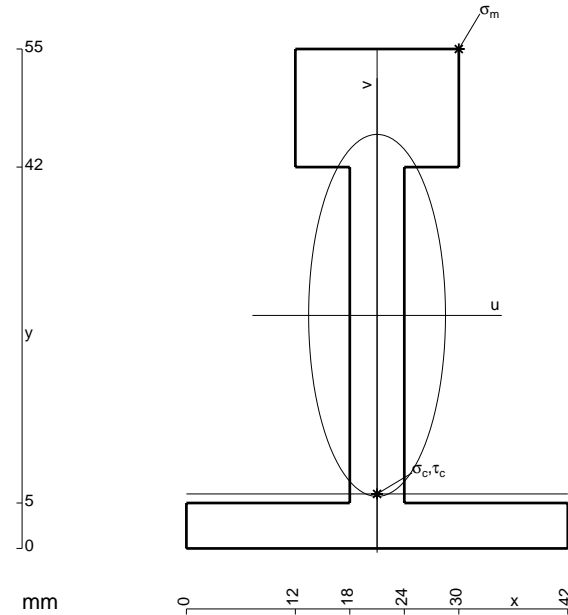

- A = 666. mm²
- J_u = 264806. mm⁴
- J_v = 37854. mm⁴
- y_g = 25.66 mm
- N = -1150. N
- T_y = -2300. N
- M_x = -1909000. Nmm
- x_m = 30. mm
- y_m = 55. mm
- u_m = 9. mm
- v_m = 29.34 mm
- σ_m = N/A-Mv/J_u = 209.8 N/mm²
- x_c = 21. mm
- y_c = 6. mm
- v_c = -19.66 mm
- σ_c = N/A-Mv/J_u = -143.5 N/mm²
- τ_c = 7.216 N/mm²
- σ_o = √σ²+3τ² = 144. N/mm²
- S = 4985. mm³

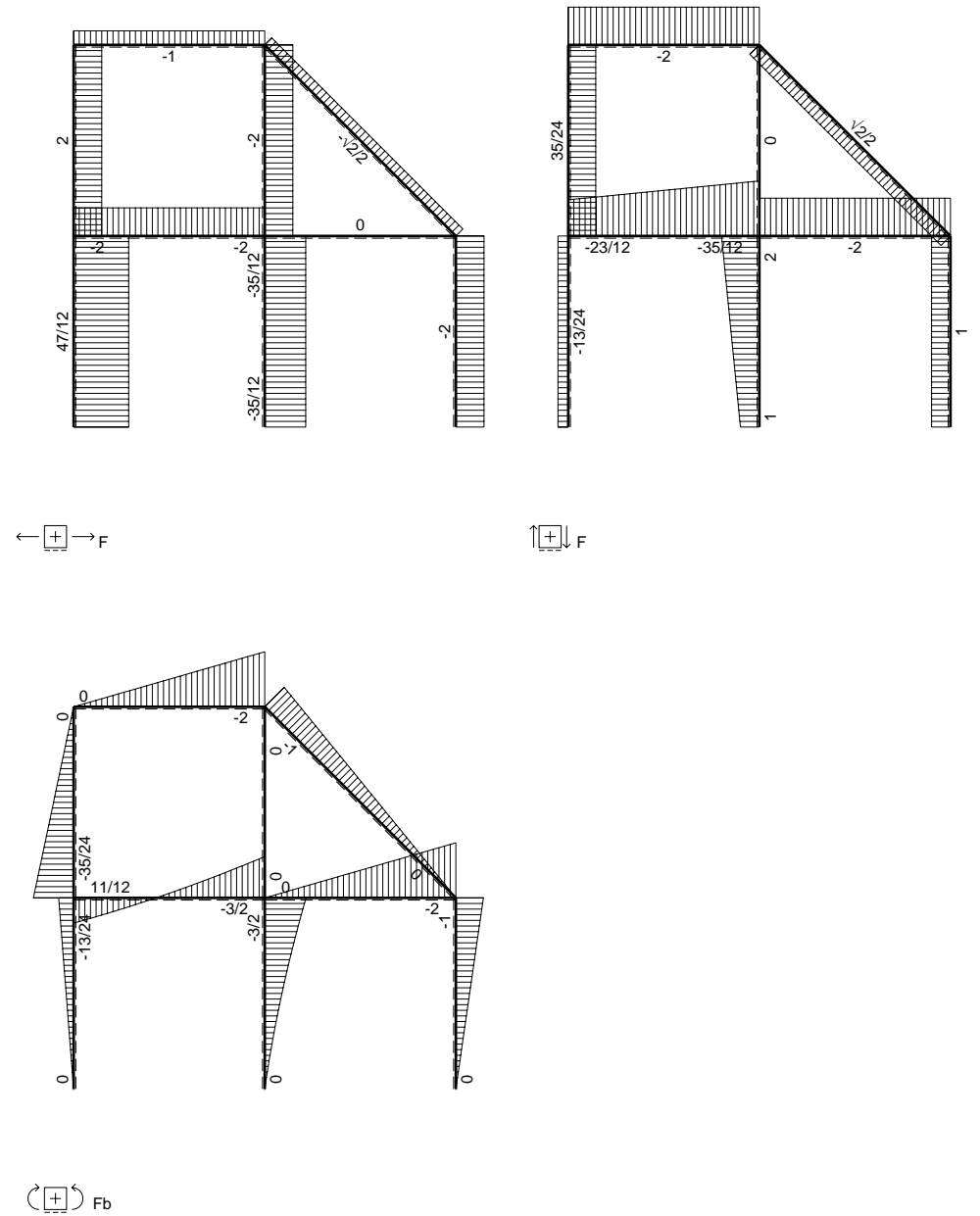
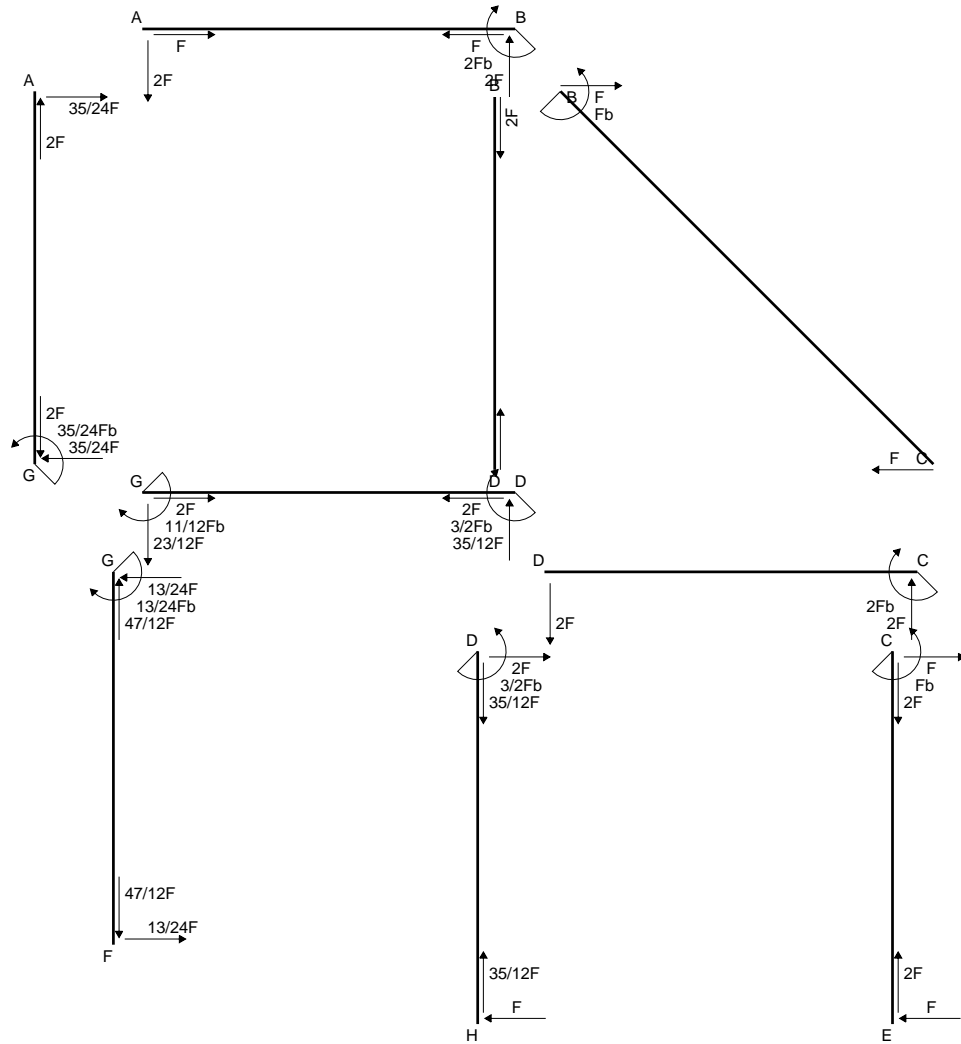

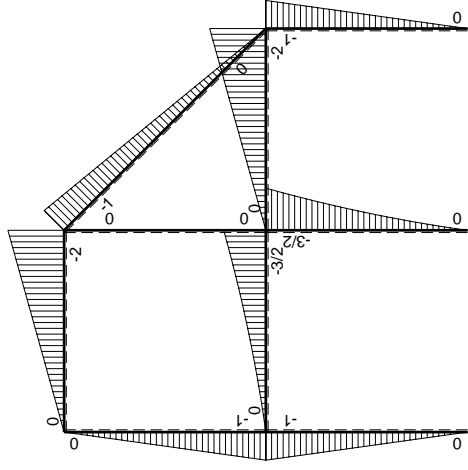
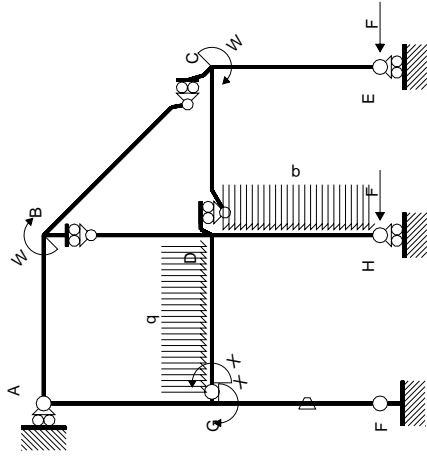

M_0 flessione da carichi assegnati

Schema di calcolo iperstatico

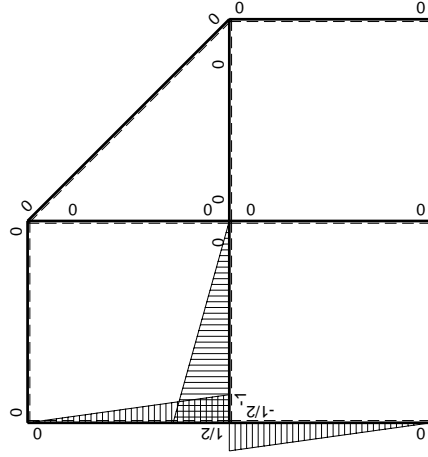

M_x flessione da iperstatica $X=1$

Quadro contributi PLV per iperstatica $X=W_{GD}$

→	$M_x(x)$	$M_o(x)$	θ	$M_x M_o$	$M_x \theta$	$M_x M_x$	$\int M_x(M_o/EJ+\theta)dx$	$\int X M_x M_x/EJdx$	
AB b	0	-2Fx	0	0	0	0	0+0	0	
BA b	0	2Fb-2Fx	0	0	0	0	0	0	
BC $\sqrt{2}b$	0	-Fb+ $\sqrt{2}/2Fx$	0	0	0	0	0	0	
BD b	0	0	0	0	0	0	0+0	0	
DB b	0	0	0	0	0	0	0	0	
DC b	0	-2Fx	0	0	0	0	0+0	0	
CD b	0	2Fb-2Fx	0	0	0	0	0	0	
CE b	0	-Fb+Fx	0	0	0	0	0+0	0	
EC b	0	Fx	0	0	0	0	0	0	
FG b	-1/2x/b	-Fx	-Fb/EJ	1/2Fx ² /b	1/2Fx/EJ	1/4x ² /b ²	(1/6+1/4)Fb ² /EJ	1/12Xb/EJ	
GF b	1/2-1/2x/b	Fb-Fx	Fb/EJ	1/2Fb-Fx+1/2Fx ² /b	1/2Fb/EJ-1/2Fx/EJ	1/4-1/2x/b+1/4x ² /b ²			
GD b	-1+x/b	-Fx-1/2qx ²	0	Fx-1/2Fx ² /b-1/2qx ³ /b	0	1-2x/b+x ² /b ²	(5/24+0)Fb ² /EJ	1/3Xb/EJ	
DG b	x/b	3/2Fb-2Fx+1/2qx ²	0	3/2Fx-2Fx ² /b+1/2qx ³ /b	0	x ² /b ²			
DH b	0	-3/2Fb+2Fx-1/2qx ²	0	0	0	0	0+0	0	
HD b	0	Fx+1/2qx ²	0	0	0	0			
GA b	1/2-1/2x/b	-Fb+Fx	0	-1/2Fb+Fx-1/2Fx ² /b	0	1/4-1/2x/b+1/4x ² /b ²	(-1/6+0)Fb ² /EJ	1/12Xb/EJ	
AG b	-1/2x/b	Fx	0	-1/2Fx ² /b	0	1/4x ² /b ²			
	totali							11/24Fb ² /EJ	1/2Xb/EJ
	iperstatica $X=W_{GD}$							-11/12Fb	

Sviluppi di calcolo iperstatica

$$L_{FG}^{xx} = \int_0^b (1/4 x^2/b^2) 1/EJ dx = [1/12 x^3/b^2]_0^b 1/EJ$$

$$= (1/12 b) 1/EJ = 1/12 b/EJ$$

$$L_{GF}^{xx} = \int_0^b (1/4 - 1/2 x/b + 1/4 x^2/b^2) 1/EJ dx = [1/4 x - 1/4 x^2/b + 1/12 x^3/b^2]_0^b 1/EJ$$

$$= (1/4 b - 1/4 b + 1/12 b) 1/EJ = 1/12 b/EJ$$

$$L_{GD}^{xx} = \int_0^b (1 - 2 x/b + x^2/b^2) 1/EJ dx = [x - x^2/b + 1/3 x^3/b^2]_0^b 1/EJ$$

$$= (b - b + 1/3 b) 1/EJ = 1/3 b/EJ$$

$$L_{DG}^{xx} = \int_0^b (x^2/b^2) 1/EJ dx = [1/3 x^3/b^2]_0^b 1/EJ$$

$$= (1/3 b) 1/EJ = 1/3 b/EJ$$

$$L_{GA}^{xx} = \int_0^b (1/4 - 1/2 x/b + 1/4 x^2/b^2) 1/EJ dx = [1/4 x - 1/4 x^2/b + 1/12 x^3/b^2]_0^b 1/EJ$$

$$= (1/4 b - 1/4 b + 1/12 b) 1/EJ = 1/12 b/EJ$$

$$L_{AG}^{xx} = \int_0^b (1/4 x^2/b^2) 1/EJ dx = [1/12 x^3/b^2]_0^b 1/EJ$$

$$= (1/12 b) 1/EJ = 1/12 b/EJ$$

$$L_{FG}^{xo} = \int_0^b (1/2 x^2/b^2) Fb 1/EJ dx + \int_0^b (1/2 x/b) \theta dx = [1/6 x^3/b^2]_0^b Fb 1/EJ + [1/4 x^2/b]_0^b \theta$$

$$= (1/6 b) Fb 1/EJ + (1/4 b) \theta = 5/12 Fb^2/EJ$$

$$L_{GF}^{xo} = \int_0^b (1/2 - x/b + 1/2 x^2/b^2) Fb 1/EJ dx + \int_0^b (-1/2 + 1/2 x/b) \theta dx$$

$$= [1/2 x - 1/2 x^2/b + 1/6 x^3/b^2]_0^b Fb 1/EJ + [-1/2 x + 1/4 x^2/b]_0^b \theta$$

$$= (1/2 b - 1/2 b + 1/6 b) Fb 1/EJ + (-1/2 b + 1/4 b) \theta = 5/12 Fb^2/EJ$$

$$L_{GD}^{xo} = \int_0^b (x/b - 1/2 x^2/b^2 - 1/2 x^3/b^3) Fb 1/EJ dx = [1/2 x^2/b - 1/6 x^3/b^2 - 1/8 x^4/b^3]_0^b Fb 1/EJ$$

$$= (1/2 b - 1/6 b - 1/8 b) Fb 1/EJ = 5/24 Fb^2/EJ$$

$$L_{DG}^{xo} = \int_0^b (3/2 x/b - 2 x^2/b^2 + 1/2 x^3/b^3) Fb 1/EJ dx = [3/4 x^2/b - 2/3 x^3/b^2 + 1/8 x^4/b^3]_0^b Fb 1/EJ$$

$$= (3/4 b - 2/3 b + 1/8 b) Fb 1/EJ = 5/24 Fb^2/EJ$$

$$L_{GA}^{xo} = \int_0^b (-1/2 + x/b - 1/2 x^2/b^2) Fb 1/EJ dx = [-1/2 x + 1/2 x^2/b - 1/6 x^3/b^2]_0^b Fb 1/EJ$$

$$= (-1/2 b + 1/2 b - 1/6 b) Fb 1/EJ = -1/6 Fb^2/EJ$$

$$L_{AG}^{xo} = \int_0^b (-1/2 x^2/b^2) Fb 1/EJ dx = [-1/6 x^3/b^2]_0^b Fb 1/EJ$$

$$= (-1/6 b) Fb 1/EJ = -1/6 Fb^2/EJ$$

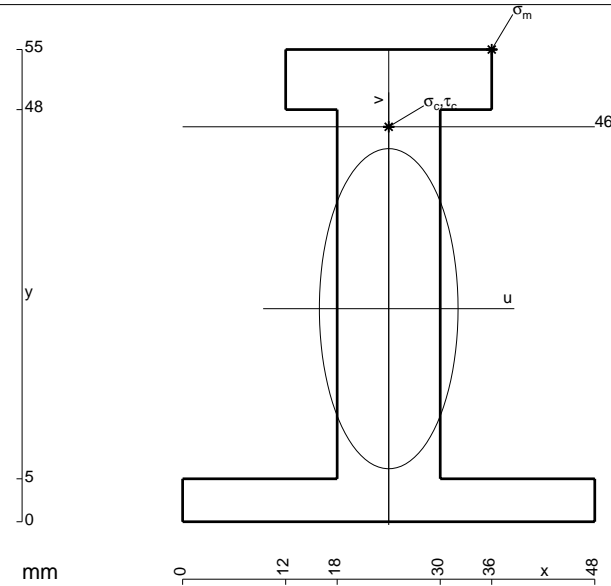

- A = 924. mm²
- J_u = 321299. mm⁴
- J_v = 60336. mm⁴
- y_g = 24.81 mm
- T_y = -2660. N
- M_x = -2340800. Nmm
- x_m = 36. mm
- y_m = 55. mm
- u_m = 12. mm
- v_m = 30.19 mm
- σ_m = -Mv/J_u = 219.9 N/mm²
- x_c = 24. mm
- y_c = 46. mm
- v_c = 21.19 mm
- σ_c = -Mv/J_u = 154.4 N/mm²
- τ_c = 3.461 N/mm²
- σ_q = √σ²+3τ² = 154.5 N/mm²
- S = 5016. mm³

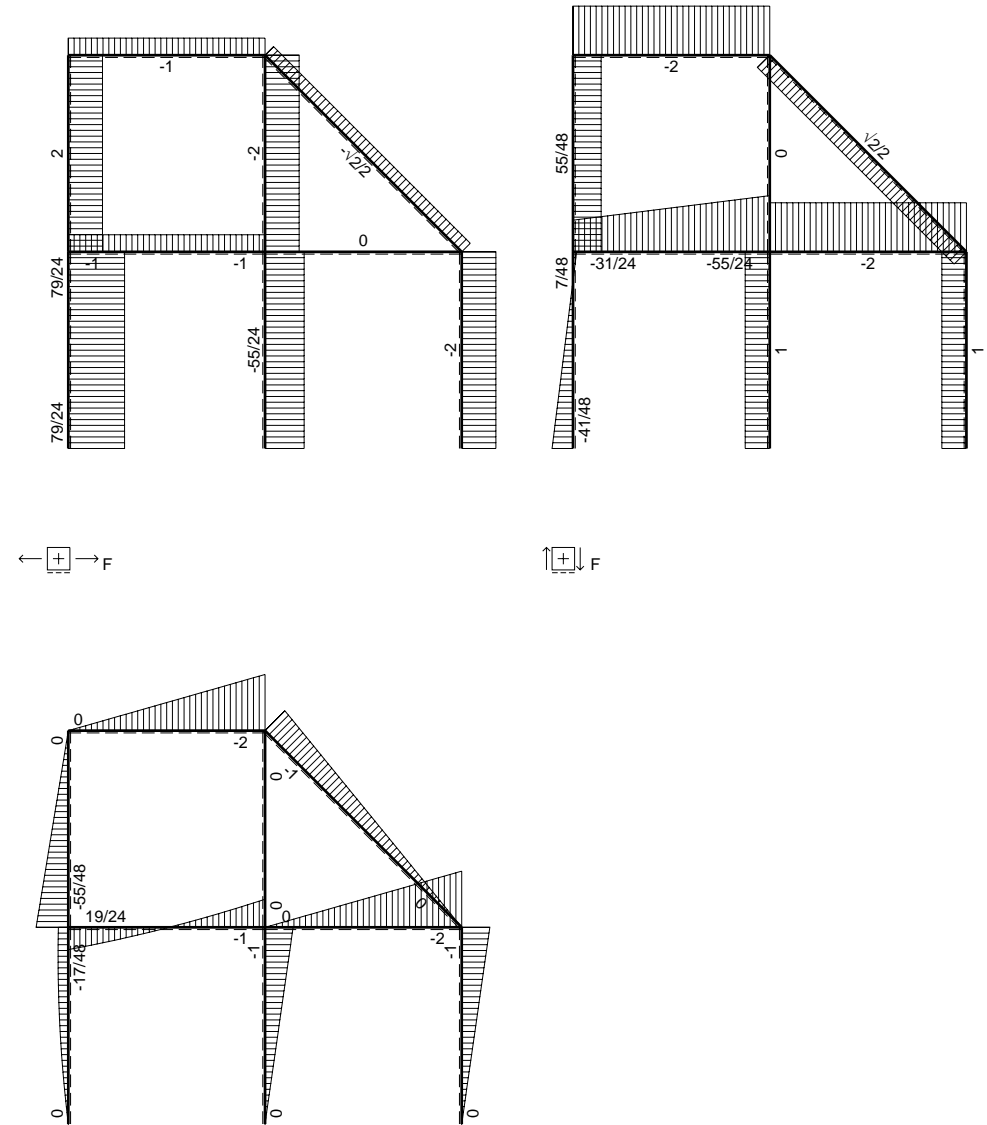
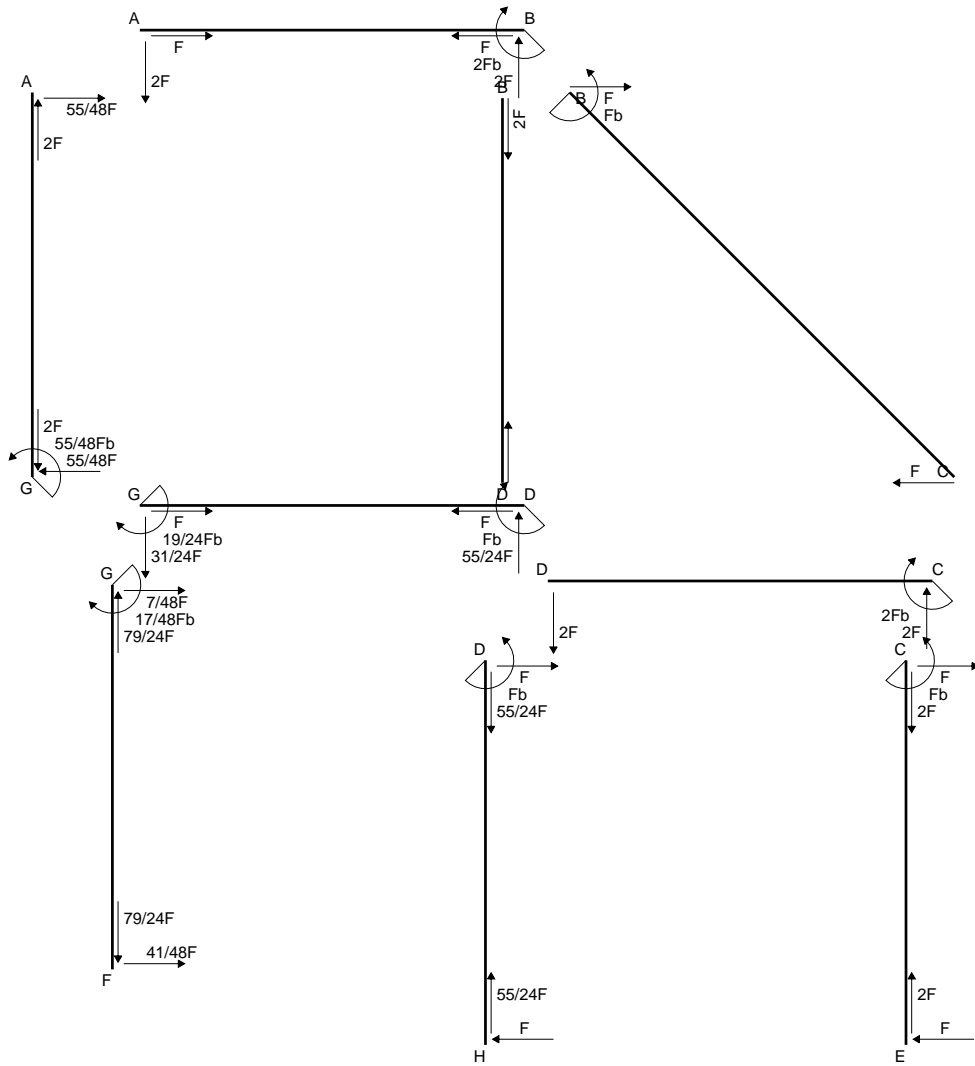

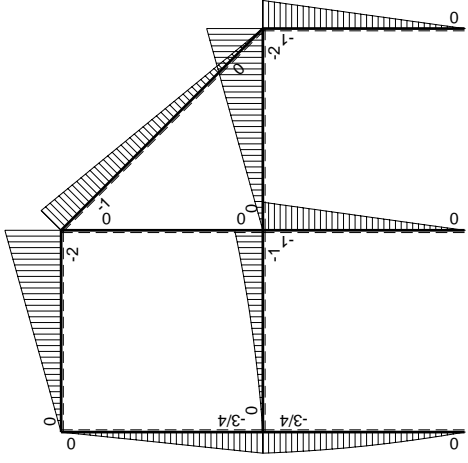
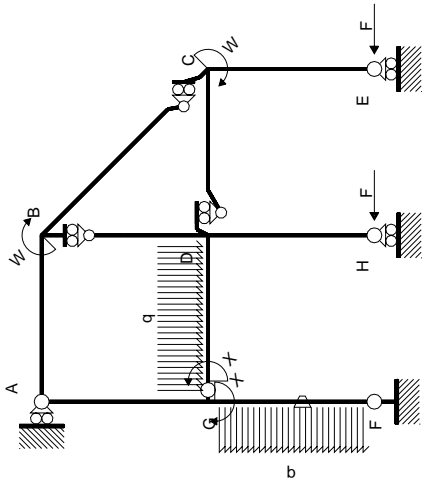

Schema di calcolo iperstatico

M_0 flessione da carichi assegnati

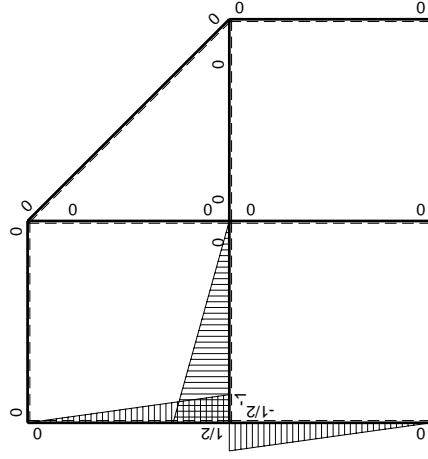

M_1 flessione da iperstatica $X=1$

Quadro contributi PLV per iperstatica $X=W_{GD}$

→	$M_x(x)$	$M_o(x)$	θ	$M_x M_o$	$M_x \theta$	$M_x M_x$	$\int M_x(M_o/EJ+\theta)dx$	$\int x M_x M_x/EJ dx$
AB b	0	-2Fx	0	0	0	0	0+0	0
BA b	0	2Fb-2Fx	0	0	0	0		
BC $\sqrt{2}b$	0	-Fb+ $\sqrt{2}/2Fx$	0	0	0	0	0	0
BD b	0	0	0	0	0	0	0+0	0
DB b	0	0	0	0	0	0		
DC b	0	-2Fx	0	0	0	0	0+0	0
CD b	0	2Fb-2Fx	0	0	0	0		
CE b	0	-Fb+Fx	0	0	0	0	0+0	0
EC b	0	Fx	0	0	0	0		
FG b	-1/2x/b	-5/4Fx+1/2qx ²	-Fb/EJ	5/8Fx ² /b-1/4qx ³ /b	1/2Fx/EJ	1/4x ² /b ²	(7/48+1/4)Fb ² /EJ	1/12Xb/EJ
GF b	1/2-1/2x/b	3/4Fb-1/4Fx-1/2qx ²	Fb/EJ	3/8Fb-1/2Fx-1/8Fx ² /b+1/4qx ³ /b	1/2Fb/EJ-1/2Fx/EJ	1/4-1/2x/b+1/4x ² /b ²		
GD b	-1+x/b	-1/2Fx-1/2qx ²	0	1/2Fx-1/2qx ³ /b	0	1-2x/b+x ² /b ²	(1/8+0)Fb ² /EJ	1/3Xb/EJ
DG b	x/b	Fb-3/2Fx+1/2qx ²	0	Fx-3/2Fx ² /b+1/2qx ³ /b	0	x ² /b ²		
DH b	0	-Fb+Fx	0	0	0	0	0+0	0
HD b	0	Fx	0	0	0	0		
GA b	1/2-1/2x/b	-3/4Fb+3/4Fx	0	-3/8Fb+3/4Fx-3/8Fx ² /b	0	1/4-1/2x/b+1/4x ² /b ²	(-1/8+0)Fb ² /EJ	1/12Xb/EJ
AG b	-1/2x/b	3/4Fx	0	-3/8Fx ² /b	0	1/4x ² /b ²		
	totali						19/48Fb ² /EJ	1/2Xb/EJ
	iperstatica $X=W_{GD}$						-19/24Fb	

Sviluppi di calcolo iperstatica

$$L_{FG}^{xx} = \int_0^b (1/4 x^2/b^2) 1/EJ dx = [1/12 x^3/b^2]_0^b 1/EJ$$

$$= (1/12 b) 1/EJ = 1/12 b/EJ$$

$$L_{GF}^{xx} = \int_0^b (1/4 - 1/2 x/b + 1/4 x^2/b^2) 1/EJ dx = [1/4 x - 1/4 x^2/b + 1/12 x^3/b^2]_0^b 1/EJ$$

$$= (1/4 b - 1/4 b + 1/12 b) 1/EJ = 1/12 b/EJ$$

$$L_{GD}^{xx} = \int_0^b (1 - 2 x/b + x^2/b^2) 1/EJ dx = [x - x^2/b + 1/3 x^3/b^2]_0^b 1/EJ$$

$$= (b - b + 1/3 b) 1/EJ = 1/3 b/EJ$$

$$L_{DG}^{xx} = \int_0^b (x^2/b^2) 1/EJ dx = [1/3 x^3/b^2]_0^b 1/EJ$$

$$= (1/3 b) 1/EJ = 1/3 b/EJ$$

$$L_{GA}^{xx} = \int_0^b (1/4 - 1/2 x/b + 1/4 x^2/b^2) 1/EJ dx = [1/4 x - 1/4 x^2/b + 1/12 x^3/b^2]_0^b 1/EJ$$

$$= (1/4 b - 1/4 b + 1/12 b) 1/EJ = 1/12 b/EJ$$

$$L_{AG}^{xx} = \int_0^b (1/4 x^2/b^2) 1/EJ dx = [1/12 x^3/b^2]_0^b 1/EJ$$

$$= (1/12 b) 1/EJ = 1/12 b/EJ$$

$$L_{FG}^{xo} = \int_0^b (5/8 x^2/b^2 - 1/4 x^3/b^3) Fb 1/EJ dx + \int_0^b (1/2 x/b) \theta dx$$

$$= [5/24 x^3/b^2 - 1/16 x^4/b^3]_0^b Fb 1/EJ + [1/4 x^2/b]_0^b \theta$$

$$= (5/24 b - 1/16 b) Fb 1/EJ + (1/4 b) \theta = 19/48 Fb^2/EJ$$

$$L_{GF}^{xo} = \int_0^b (3/8 - 1/2 x/b - 1/8 x^2/b^2 + 1/4 x^3/b^3) Fb 1/EJ dx + \int_0^b (-1/2 + 1/2 x/b) \theta dx$$

$$= [3/8 x - 1/4 x^2/b - 1/24 x^3/b^2 + 1/16 x^4/b^3]_0^b Fb 1/EJ + [-1/2 x + 1/4 x^2/b]_0^b \theta$$

$$= (3/8 b - 1/4 b - 1/24 b + 1/16 b) Fb 1/EJ + (-1/2 b + 1/4 b) \theta = 19/48 Fb^2/EJ$$

$$L_{GD}^{xo} = \int_0^b (1/2 x/b - 1/2 x^3/b^3) Fb 1/EJ dx = [1/4 x^2/b - 1/8 x^4/b^3]_0^b Fb 1/EJ$$

$$= (1/4 b - 1/8 b) Fb 1/EJ = 1/8 Fb^2/EJ$$

$$L_{DG}^{xo} = \int_0^b (x/b - 3/2 x^2/b^2 + 1/2 x^3/b^3) Fb 1/EJ dx = [1/2 x^2/b - 1/2 x^3/b^2 + 1/8 x^4/b^3]_0^b Fb 1/EJ$$

$$= (1/2 b - 1/2 b + 1/8 b) Fb 1/EJ = 1/8 Fb^2/EJ$$

$$L_{GA}^{xo} = \int_0^b (-3/8 + 3/4 x/b - 3/8 x^2/b^2) Fb 1/EJ dx = [-3/8 x + 3/8 x^2/b - 1/8 x^3/b^2]_0^b Fb 1/EJ$$

$$= (-3/8 b + 3/8 b - 1/8 b) Fb 1/EJ = -1/8 Fb^2/EJ$$

$$L_{AG}^{xo} = \int_0^b (-3/8 x^2/b^2) Fb 1/EJ dx = [-1/8 x^3/b^2]_0^b Fb 1/EJ$$

$$= (-1/8 b) Fb 1/EJ = -1/8 Fb^2/EJ$$

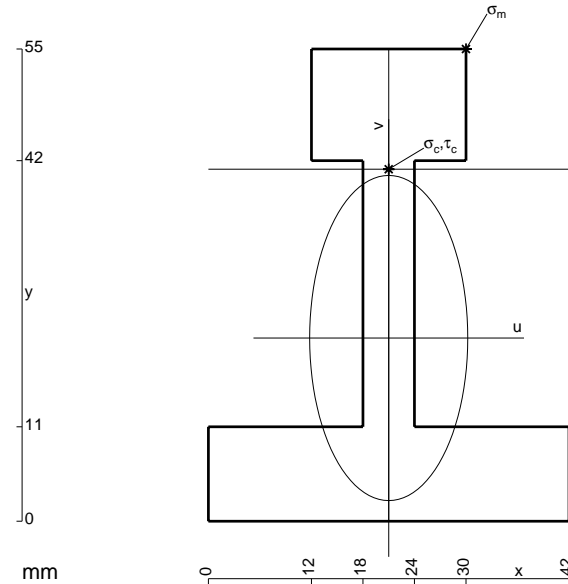

- A = 882. mm²
- J_u = 316334. mm⁴
- J_v = 74790. mm⁴
- y_g = 21.34 mm
- T_y = -2320. N
- M_x = -2157600. Nmm
- x_m = 30. mm
- y_m = 55. mm
- u_m = 9. mm
- v_m = 33.66 mm
- σ_m = -Mv/J_u = 229.6 N/mm²
- x_c = 21. mm
- y_c = 41. mm
- v_c = 19.66 mm
- σ_c = -Mv/J_u = 134.1 N/mm²
- τ_c = 7.917 N/mm²
- σ_o = √σ²+3τ² = 134.8 N/mm²
- S = 6477. mm³

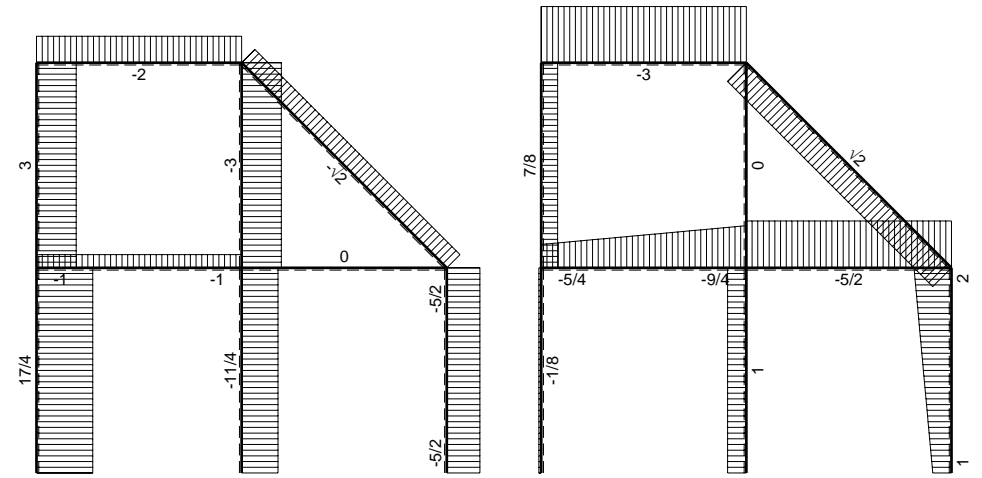
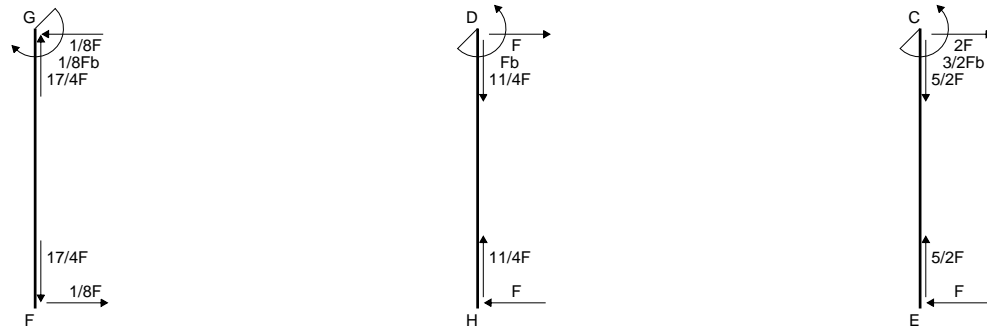
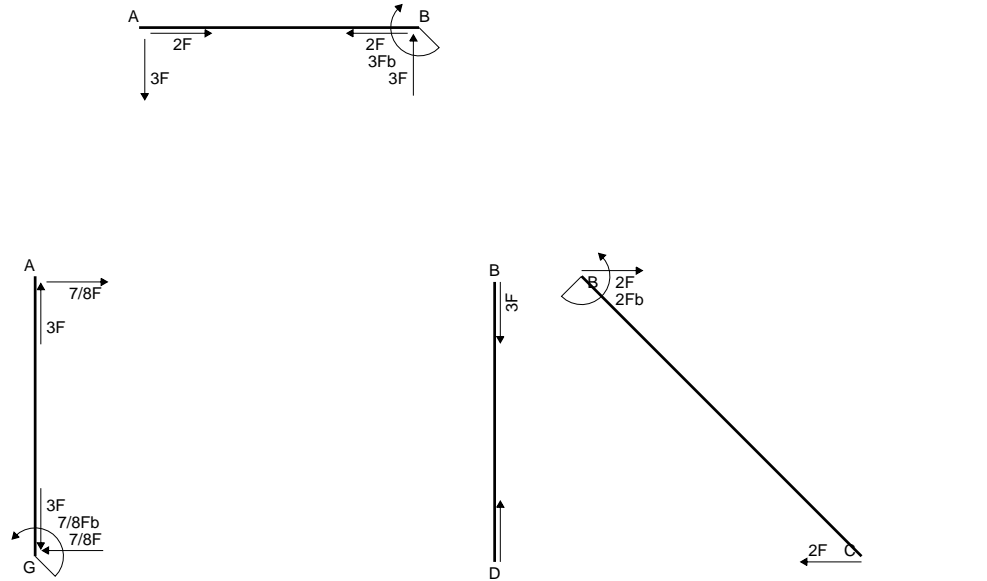

← ⊕ → F

↑ ⊕ ↓ F

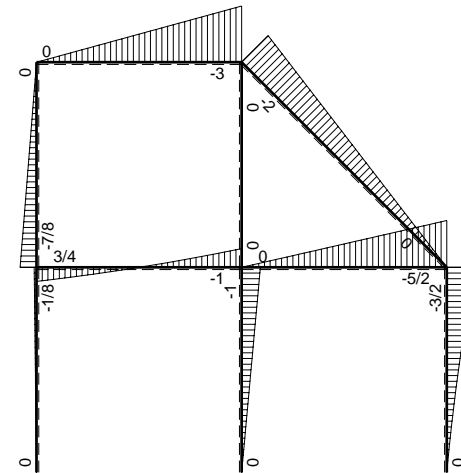

⊕ ⊖ Fb

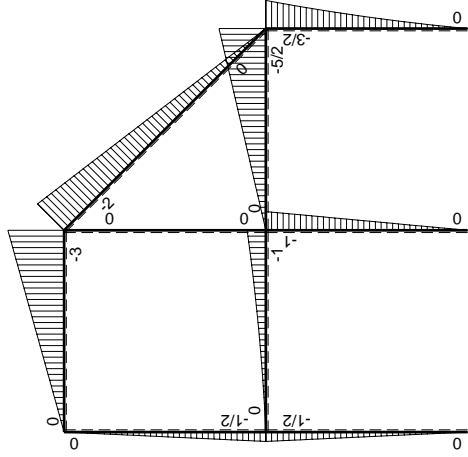
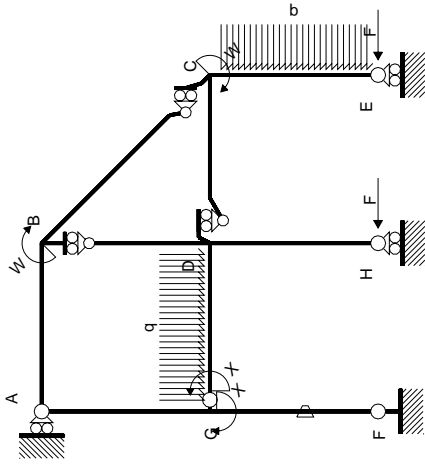

Schema di calcolo iperstatico

M_0 flessione da carichi assegnati

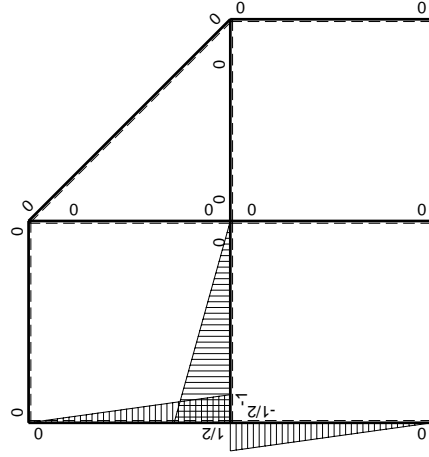

M_x flessione da iperstatica $X=1$

Quadro contributi PLV per iperstatica $X=W_{GD}$

→	$M_x(x)$	$M_o(x)$	θ	$M_x M_o$	$M_x \theta$	$M_x M_x$	$\int M_x(M_o/EJ+\theta)dx$	$\int X M_x M_x/EJ dx$	
AB b	0	-3Fx	0	0	0	0	0+0	0	
BA b	0	3Fb-3Fx	0	0	0	0			
BC $\sqrt{2}b$	0	-2Fb+ $\sqrt{2}Fx$	0	0	0	0	0	0	
BD b	0	0	0	0	0	0	0+0	0	
DB b	0	0	0	0	0	0			
DC b	0	-5/2Fx	0	0	0	0	0+0	0	
CD b	0	5/2Fb-5/2Fx	0	0	0	0			
CE b	0	-3/2Fb+2Fx-1/2qx ²	0	0	0	0	0+0	0	
EC b	0	Fx+1/2qx ²	0	0	0	0			
FG b	-1/2x/b	-1/2Fx	-Fb/EJ	1/4Fx ² /b	1/2Fx/EJ	1/4x ² /b ²	(1/12+1/4)Fb ² /EJ	1/12Xb/EJ	
GF b	1/2-1/2x/b	1/2Fb-1/2Fx	Fb/EJ	1/4Fb-1/2Fx+1/4Fx ² /b	1/2Fb/EJ-1/2Fx/EJ	1/4-1/2x/b+1/4x ² /b ²			
GD b	-1+x/b	-1/2Fx-1/2qx ²	0	1/2Fx-1/2qx ³ /b	0	1-2x/b+x ² /b ²	(1/8+0)Fb ² /EJ	1/3Xb/EJ	
DG b	x/b	Fb-3/2Fx+1/2qx ²	0	Fx-3/2Fx ² /b+1/2qx ³ /b	0	x ² /b ²			
DH b	0	-Fb+Fx	0	0	0	0	0+0	0	
HD b	0	Fx	0	0	0	0			
GA b	1/2-1/2x/b	-1/2Fb+1/2Fx	0	-1/4Fb+1/2Fx-1/4Fx ² /b	0	1/4-1/2x/b+1/4x ² /b ²	(-1/12+0)Fb ² /EJ	1/12Xb/EJ	
AG b	-1/2x/b	1/2Fx	0	-1/4Fx ² /b	0	1/4x ² /b ²			
	totali							3/8Fb ² /EJ	1/2Xb/EJ
	iperstatica $X=W_{GD}$							-3/4Fb	

Sviluppi di calcolo iperstatica

$$L_{FG}^{xx} = \int_0^b (1/4 x^2/b^2) 1/EJ dx = [1/12 x^3/b^2]_0^b 1/EJ$$

$$= (1/12 b) 1/EJ = 1/12 b/EJ$$

$$L_{GF}^{xx} = \int_0^b (1/4 - 1/2 x/b + 1/4 x^2/b^2) 1/EJ dx = [1/4 x - 1/4 x^2/b + 1/12 x^3/b^2]_0^b 1/EJ$$

$$= (1/4 b - 1/4 b + 1/12 b) 1/EJ = 1/12 b/EJ$$

$$L_{GD}^{xx} = \int_0^b (1 - 2 x/b + x^2/b^2) 1/EJ dx = [x - x^2/b + 1/3 x^3/b^2]_0^b 1/EJ$$

$$= (b - b + 1/3 b) 1/EJ = 1/3 b/EJ$$

$$L_{DG}^{xx} = \int_0^b (x^2/b^2) 1/EJ dx = [1/3 x^3/b^2]_0^b 1/EJ$$

$$= (1/3 b) 1/EJ = 1/3 b/EJ$$

$$L_{GA}^{xx} = \int_0^b (1/4 - 1/2 x/b + 1/4 x^2/b^2) 1/EJ dx = [1/4 x - 1/4 x^2/b + 1/12 x^3/b^2]_0^b 1/EJ$$

$$= (1/4 b - 1/4 b + 1/12 b) 1/EJ = 1/12 b/EJ$$

$$L_{AG}^{xx} = \int_0^b (1/4 x^2/b^2) 1/EJ dx = [1/12 x^3/b^2]_0^b 1/EJ$$

$$= (1/12 b) 1/EJ = 1/12 b/EJ$$

$$L_{FG}^{xo} = \int_0^b (1/4 x^2/b^2) Fb 1/EJ dx + \int_0^b (1/2 x/b) \theta dx = [1/12 x^3/b^2]_0^b Fb 1/EJ + [1/4 x^2/b]_0^b \theta$$

$$= (1/12 b) Fb 1/EJ + (1/4 b) \theta = 1/3 Fb^2/EJ$$

$$L_{GF}^{xo} = \int_0^b (1/4 - 1/2 x/b + 1/4 x^2/b^2) Fb 1/EJ dx + \int_0^b (-1/2 + 1/2 x/b) \theta dx$$

$$= [1/4 x - 1/4 x^2/b + 1/12 x^3/b^2]_0^b Fb 1/EJ + [-1/2 x + 1/4 x^2/b]_0^b \theta$$

$$= (1/4 b - 1/4 b + 1/12 b) Fb 1/EJ + (-1/2 b + 1/4 b) \theta = 1/3 Fb^2/EJ$$

$$L_{GD}^{xo} = \int_0^b (1/2 x/b - 1/2 x^3/b^3) Fb 1/EJ dx = [1/4 x^2/b - 1/8 x^4/b^3]_0^b Fb 1/EJ$$

$$= (1/4 b - 1/8 b) Fb 1/EJ = 1/8 Fb^2/EJ$$

$$L_{DG}^{xo} = \int_0^b (x/b - 3/2 x^2/b^2 + 1/2 x^3/b^3) Fb 1/EJ dx = [1/2 x^2/b - 1/2 x^3/b^2 + 1/8 x^4/b^3]_0^b Fb 1/EJ$$

$$= (1/2 b - 1/2 b + 1/8 b) Fb 1/EJ = 1/8 Fb^2/EJ$$

$$L_{GA}^{xo} = \int_0^b (-1/4 + 1/2 x/b - 1/4 x^2/b^2) Fb 1/EJ dx = [-1/4 x + 1/4 x^2/b - 1/12 x^3/b^2]_0^b Fb 1/EJ$$

$$= (-1/4 b + 1/4 b - 1/12 b) Fb 1/EJ = -1/12 Fb^2/EJ$$

$$L_{AG}^{xo} = \int_0^b (-1/4 x^2/b^2) Fb 1/EJ dx = [-1/12 x^3/b^2]_0^b Fb 1/EJ$$

$$= (-1/12 b) Fb 1/EJ = -1/12 Fb^2/EJ$$

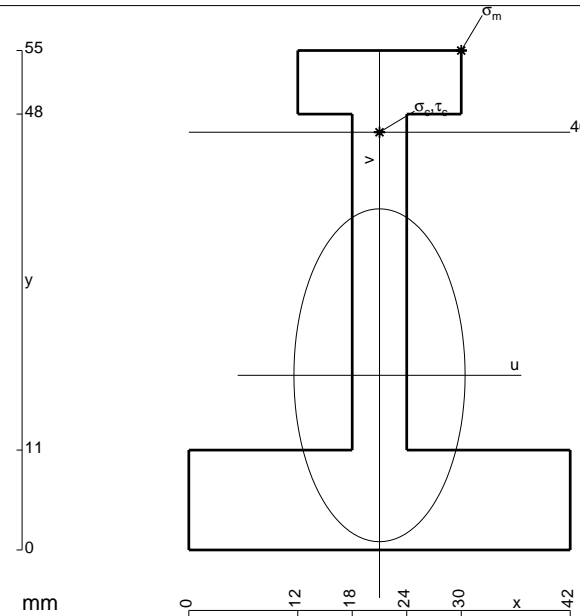

- A = 810. mm²
- J_u = 272218. mm⁴
- J_v = 71982. mm⁴
- y_g = 19.23 mm
- N = -1240. N
- T_y = -1860. N
- M_x = -1822800. Nmm
- x_m = 30. mm
- y_m = 55. mm
- u_m = 9. mm
- v_m = 35.77 mm
- σ_m = N/A - Mv/J_u = 238. N/mm²
- x_c = 21. mm
- y_c = 46. mm
- v_c = 26.77 mm
- σ_c = N/A - Mv/J_u = 177.7 N/mm²
- τ_c = 5.009 N/mm²
- σ_o = √(σ² + 3τ²) = 177.9 N/mm²
- S = 4399. mm³

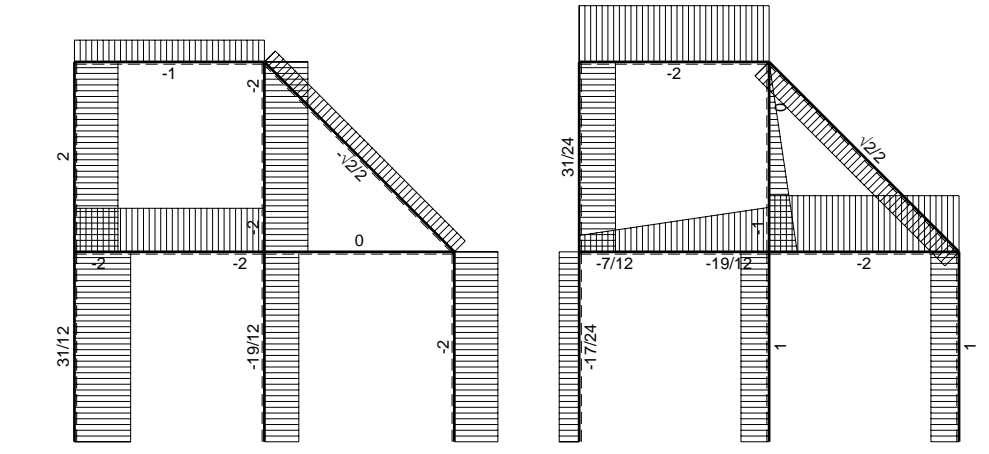
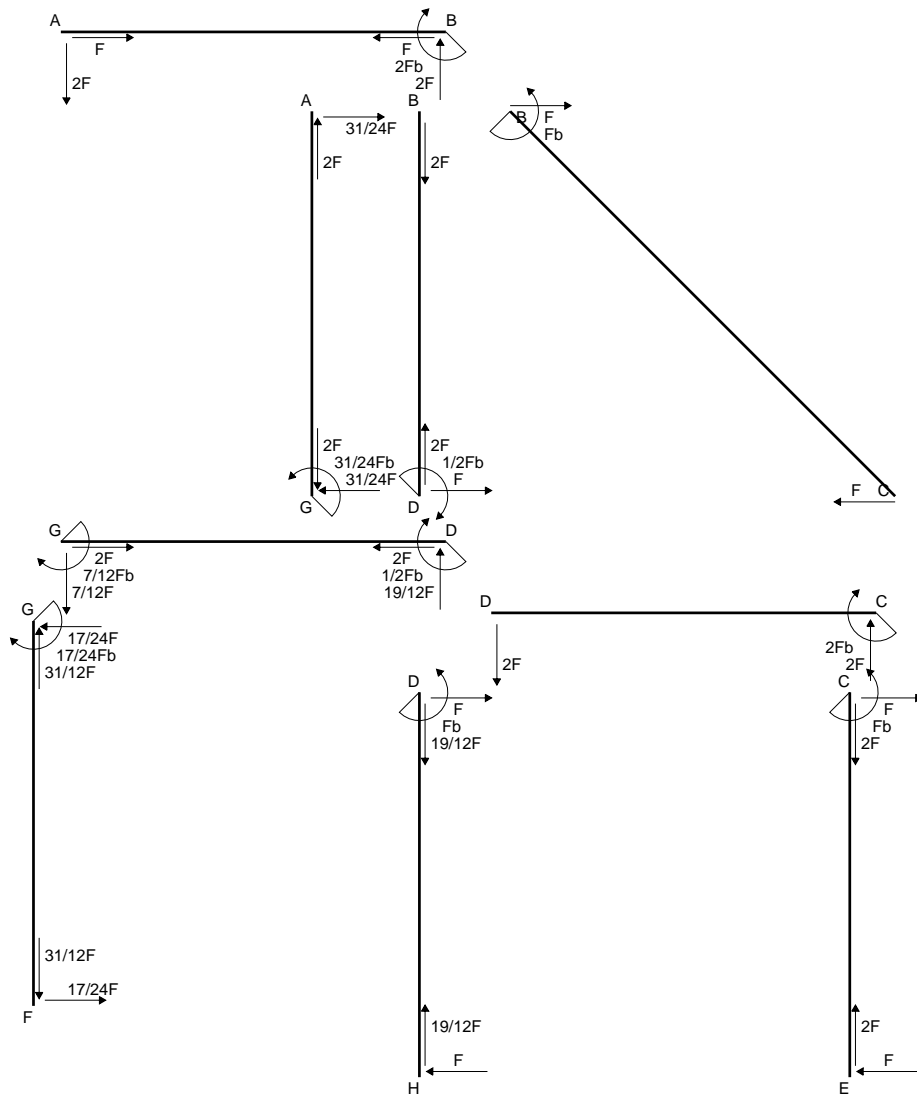

← ⊕ → F

↑ ⊕ ↓ F

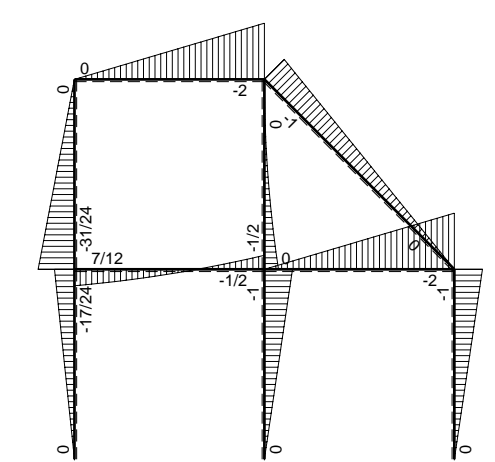

⊕ ⊖ F_b

Quadro contributi PLV per iperstatica $X=W_{GD}$

→	$M_x(x)$	$M_o(x)$	θ	$M_x M_o$	$M_x \theta$	$M_x M_x$	$\int M_x(M_o/EJ+\theta)dx$	$\int X M_x M_x/EJdx$	
AB b	0	-2Fx	0	0	0	0	0+0	0	
BA b	0	2Fb-2Fx	0	0	0	0			
BC $\sqrt{2}b$	0	-Fb+ $\sqrt{2}/2Fx$	0	0	0	0	0	0	
BD b	0	-1/2qx ²	0	0	0	0	0+0	0	
DB b	0	1/2Fb-Fx+1/2qx ²	0	0	0	0			
DC b	0	-2Fx	0	0	0	0	0+0	0	
CD b	0	2Fb-2Fx	0	0	0	0			
CE b	0	-Fb+Fx	0	0	0	0	0+0	0	
EC b	0	Fx	0	0	0	0			
FG b	-1/2x/b	-Fx	-Fb/EJ	1/2Fx ² /b	1/2Fx/EJ	1/4x ² /b ²	(1/6+1/4)Fb ² /EJ	1/12Xb/EJ	
GF b	1/2-1/2x/b	Fb-Fx	Fb/EJ	1/2Fb-Fx+1/2Fx ² /b	1/2Fb/EJ-1/2Fx/EJ	1/4-1/2x/b+1/4x ² /b ²			
GD b	-1+x/b	-1/2qx ²	0	1/2Fx ² /b-1/2qx ³ /b	0	1-2x/b+x ² /b ²	(1/24+0)Fb ² /EJ	1/3Xb/EJ	
DG b	x/b	1/2Fb-Fx+1/2qx ²	0	1/2Fx-Fx ² /b+1/2qx ³ /b	0	x ² /b ²			
DH b	0	-Fb+Fx	0	0	0	0	0+0	0	
HD b	0	Fx	0	0	0	0			
GA b	1/2-1/2x/b	-Fb+Fx	0	-1/2Fb+Fx-1/2Fx ² /b	0	1/4-1/2x/b+1/4x ² /b ²	(-1/6+0)Fb ² /EJ	1/12Xb/EJ	
AG b	-1/2x/b	Fx	0	-1/2Fx ² /b	0	1/4x ² /b ²			
	totali							7/24Fb ² /EJ	1/2Xb/EJ
	iperstatica $X=W_{GD}$							-7/12Fb	

Sviluppi di calcolo iperstatica

$$L_{FG}^{xx} = \int_0^b (1/4 x^2/b^2) 1/EJ dx = [1/12 x^3/b^2]_0^b 1/EJ$$

$$= (1/12 b) 1/EJ = 1/12 b/EJ$$

$$L_{GF}^{xx} = \int_0^b (1/4 - 1/2 x/b + 1/4 x^2/b^2) 1/EJ dx = [1/4 x - 1/4 x^2/b + 1/12 x^3/b^2]_0^b 1/EJ$$

$$= (1/4 b - 1/4 b + 1/12 b) 1/EJ = 1/12 b/EJ$$

$$L_{GD}^{xx} = \int_0^b (1 - 2 x/b + x^2/b^2) 1/EJ dx = [x - x^2/b + 1/3 x^3/b^2]_0^b 1/EJ$$

$$= (b - b + 1/3 b) 1/EJ = 1/3 b/EJ$$

$$L_{DG}^{xx} = \int_0^b (x^2/b^2) 1/EJ dx = [1/3 x^3/b^2]_0^b 1/EJ$$

$$= (1/3 b) 1/EJ = 1/3 b/EJ$$

$$L_{GA}^{xx} = \int_0^b (1/4 - 1/2 x/b + 1/4 x^2/b^2) 1/EJ dx = [1/4 x - 1/4 x^2/b + 1/12 x^3/b^2]_0^b 1/EJ$$

$$= (1/4 b - 1/4 b + 1/12 b) 1/EJ = 1/12 b/EJ$$

$$L_{AG}^{xx} = \int_0^b (1/4 x^2/b^2) 1/EJ dx = [1/12 x^3/b^2]_0^b 1/EJ$$

$$= (1/12 b) 1/EJ = 1/12 b/EJ$$

$$L_{FG}^{xo} = \int_0^b (1/2 x^2/b^2) Fb 1/EJ dx + \int_0^b (1/2 x/b) \theta dx = [1/6 x^3/b^2]_0^b Fb 1/EJ + [1/4 x^2/b]_0^b \theta$$

$$= (1/6 b) Fb 1/EJ + (1/4 b) \theta = 5/12 Fb^2/EJ$$

$$L_{GF}^{xo} = \int_0^b (1/2 - x/b + 1/2 x^2/b^2) Fb 1/EJ dx + \int_0^b (-1/2 + 1/2 x/b) \theta dx$$

$$= [1/2 x - 1/2 x^2/b + 1/6 x^3/b^2]_0^b Fb 1/EJ + [-1/2 x + 1/4 x^2/b]_0^b \theta$$

$$= (1/2 b - 1/2 b + 1/6 b) Fb 1/EJ + (-1/2 b + 1/4 b) \theta = 5/12 Fb^2/EJ$$

$$L_{GD}^{xo} = \int_0^b (1/2 x^2/b^2 - 1/2 x^3/b^3) Fb 1/EJ dx = [1/6 x^3/b^2 - 1/8 x^4/b^3]_0^b Fb 1/EJ$$

$$= (1/6 b - 1/8 b) Fb 1/EJ = 1/24 Fb^2/EJ$$

$$L_{DG}^{xo} = \int_0^b (1/2 x/b - x^2/b^2 + 1/2 x^3/b^3) Fb 1/EJ dx = [1/4 x^2/b - 1/3 x^3/b^2 + 1/8 x^4/b^3]_0^b Fb 1/EJ$$

$$= (1/4 b - 1/3 b + 1/8 b) Fb 1/EJ = 1/24 Fb^2/EJ$$

$$L_{GA}^{xo} = \int_0^b (-1/2 + x/b - 1/2 x^2/b^2) Fb 1/EJ dx = [-1/2 x + 1/2 x^2/b - 1/6 x^3/b^2]_0^b Fb 1/EJ$$

$$= (-1/2 b + 1/2 b - 1/6 b) Fb 1/EJ = -1/6 Fb^2/EJ$$

$$L_{AG}^{xo} = \int_0^b (-1/2 x^2/b^2) Fb 1/EJ dx = [-1/6 x^3/b^2]_0^b Fb 1/EJ$$

$$= (-1/6 b) Fb 1/EJ = -1/6 Fb^2/EJ$$

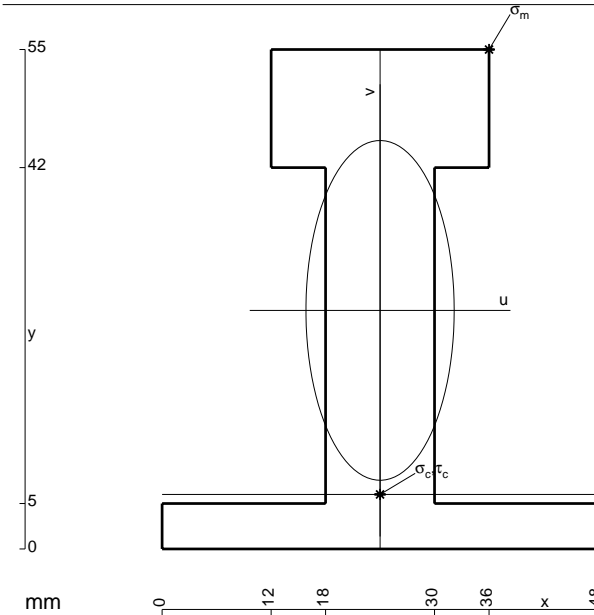

- A = 996. mm²
- J_u = 348739. mm⁴
- J_v = 66384. mm⁴
- y_g = 26.27 mm
- N = -2360. N
- T_y = -4720. N
- M_x = -2454400. Nmm
- x_m = 36. mm
- y_m = 55. mm
- u_m = 12. mm
- v_m = 28.73 mm
- σ_m = N/A-Mv/J_u = 199.8 N/mm²
- x_c = 24. mm
- y_c = 6. mm
- v_c = -20.27 mm
- σ_c = N/A-Mv/J_u = -145. N/mm²
- τ_c = 6.716 N/mm²
- σ_o = √σ²+3τ² = 145.5 N/mm²
- S = 5954. mm³

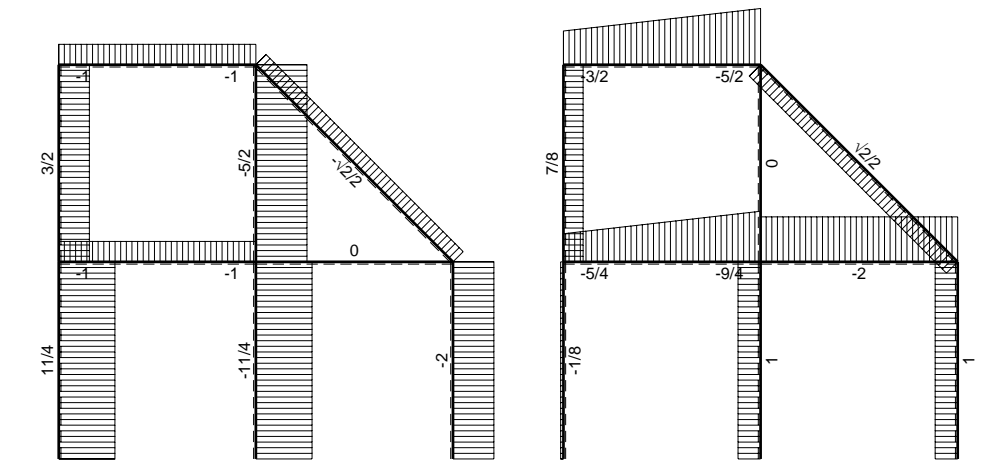
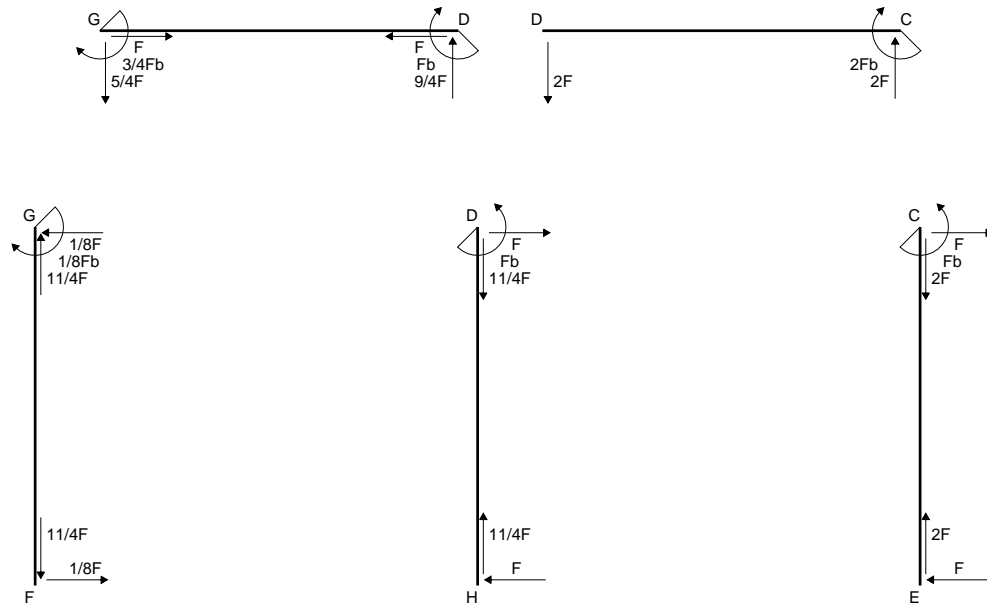
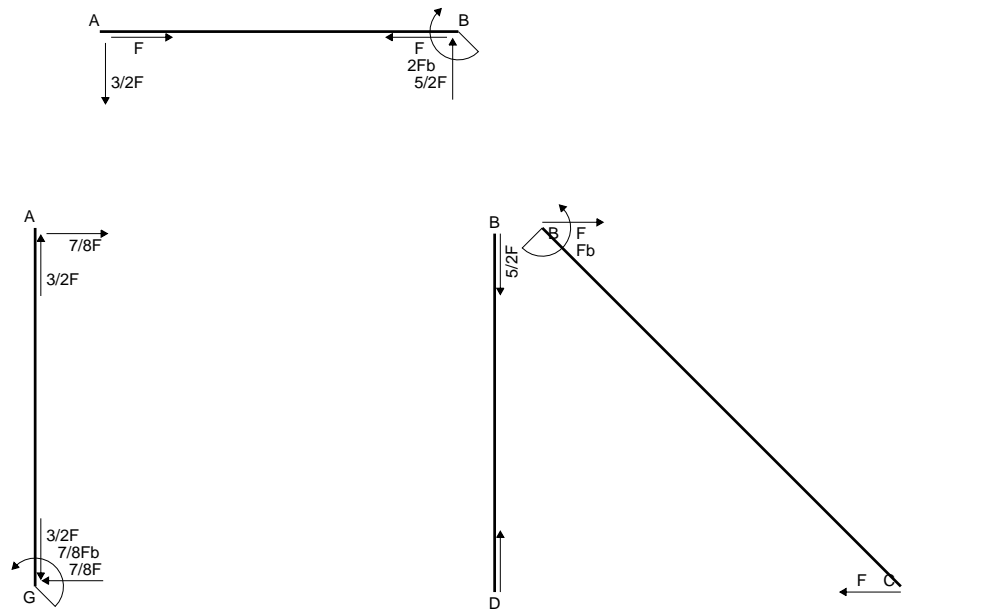

← ⊕ → F

↑ ⊕ ↓ F_b

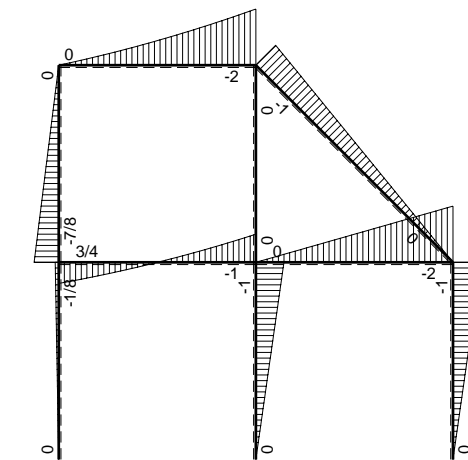

← ⊕ → F_b

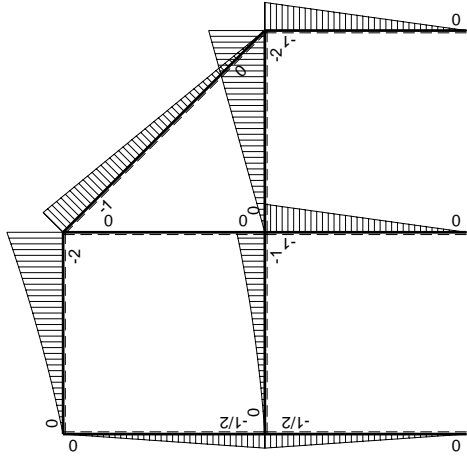
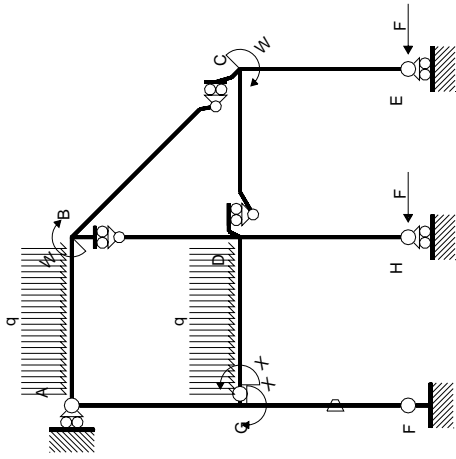

Schema di calcolo iperstatico

M_0 flessione da carichi assegnati

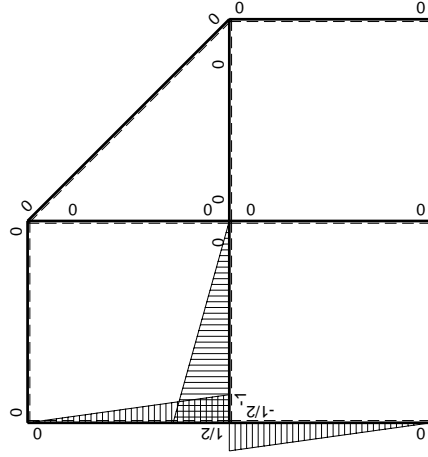

M_x flessione da iperstatica $X=1$

Quadro contributi PLV per iperstatica $X=W_{GD}$

→	$M_x(x)$	$M_o(x)$	θ	$M_x M_o$	$M_x \theta$	$M_x M_x$	$\int M_x(M_o/EJ+\theta)dx$	$\int X M_x M_x/EJ dx$
AB b	0	$-3/2Fx-1/2qx^2$	0	0	0	0	0+0	0
BA b	0	$2Fb-5/2Fx+1/2qx^2$	0	0	0	0		
BC $\sqrt{2}b$	0	$-Fb+\sqrt{2}/2Fx$	0	0	0	0	0	0
BD b	0	0	0	0	0	0	0+0	0
DB b	0	0	0	0	0	0		
DC b	0	$-2Fx$	0	0	0	0	0+0	0
CD b	0	$2Fb-2Fx$	0	0	0	0		
CE b	0	$-Fb+Fx$	0	0	0	0	0+0	0
EC b	0	Fx	0	0	0	0		
FG b	$-1/2x/b$	$-1/2Fx$	$-Fb/EJ$	$1/4Fx^2/b$	$1/2Fx/EJ$	$1/4x^2/b^2$	$(1/12+1/4)Fb^2/EJ$	$1/12Xb/EJ$
GF b	$1/2-1/2x/b$	$1/2Fb-1/2Fx$	Fb/EJ	$1/4Fb-1/2Fx+1/4Fx^2/b$	$1/2Fb/EJ-1/2Fx/EJ$	$1/4-1/2x/b+1/4x^2/b^2$		
GD b	$-1+x/b$	$-1/2Fx-1/2qx^2$	0	$1/2Fx-1/2qx^3/b$	0	$1-2x/b+x^2/b^2$	$(1/8+0)Fb^2/EJ$	$1/3Xb/EJ$
DG b	x/b	$Fb-3/2Fx+1/2qx^2$	0	$Fx-3/2Fx^2/b+1/2qx^3/b$	0	x^2/b^2		
DH b	0	$-Fb+Fx$	0	0	0	0	0+0	0
HD b	0	Fx	0	0	0	0		
GA b	$1/2-1/2x/b$	$-1/2Fb+1/2Fx$	0	$-1/4Fb+1/2Fx-1/4Fx^2/b$	0	$1/4-1/2x/b+1/4x^2/b^2$	$(-1/12+0)Fb^2/EJ$	$1/12Xb/EJ$
AG b	$-1/2x/b$	$1/2Fx$	0	$-1/4Fx^2/b$	0	$1/4x^2/b^2$		
	totali						$3/8Fb^2/EJ$	$1/2Xb/EJ$
	iperstatica $X=W_{GD}$						$-3/4Fb$	

Sviluppi di calcolo iperstatica

$$L_{FG}^{xx} = \int_0^b (1/4 x^2/b^2) 1/EJ dx = [1/12 x^3/b^2]_0^b 1/EJ$$

$$= (1/12 b) 1/EJ = 1/12 b/EJ$$

$$L_{GF}^{xx} = \int_0^b (1/4 - 1/2 x/b + 1/4 x^2/b^2) 1/EJ dx = [1/4 x - 1/4 x^2/b + 1/12 x^3/b^2]_0^b 1/EJ$$

$$= (1/4 b - 1/4 b + 1/12 b) 1/EJ = 1/12 b/EJ$$

$$L_{GD}^{xx} = \int_0^b (1 - 2 x/b + x^2/b^2) 1/EJ dx = [x - x^2/b + 1/3 x^3/b^2]_0^b 1/EJ$$

$$= (b - b + 1/3 b) 1/EJ = 1/3 b/EJ$$

$$L_{DG}^{xx} = \int_0^b (x^2/b^2) 1/EJ dx = [1/3 x^3/b^2]_0^b 1/EJ$$

$$= (1/3 b) 1/EJ = 1/3 b/EJ$$

$$L_{GA}^{xx} = \int_0^b (1/4 - 1/2 x/b + 1/4 x^2/b^2) 1/EJ dx = [1/4 x - 1/4 x^2/b + 1/12 x^3/b^2]_0^b 1/EJ$$

$$= (1/4 b - 1/4 b + 1/12 b) 1/EJ = 1/12 b/EJ$$

$$L_{AG}^{xx} = \int_0^b (1/4 x^2/b^2) 1/EJ dx = [1/12 x^3/b^2]_0^b 1/EJ$$

$$= (1/12 b) 1/EJ = 1/12 b/EJ$$

$$L_{FG}^{xo} = \int_0^b (1/4 x^2/b^2) Fb 1/EJ dx + \int_0^b (1/2 x/b) \theta dx = [1/12 x^3/b^2]_0^b Fb 1/EJ + [1/4 x^2/b]_0^b \theta$$

$$= (1/12 b) Fb 1/EJ + (1/4 b) \theta = 1/3 Fb^2/EJ$$

$$L_{GF}^{xo} = \int_0^b (1/4 - 1/2 x/b + 1/4 x^2/b^2) Fb 1/EJ dx + \int_0^b (-1/2 + 1/2 x/b) \theta dx$$

$$= [1/4 x - 1/4 x^2/b + 1/12 x^3/b^2]_0^b Fb 1/EJ + [-1/2 x + 1/4 x^2/b]_0^b \theta$$

$$= (1/4 b - 1/4 b + 1/12 b) Fb 1/EJ + (-1/2 b + 1/4 b) \theta = 1/3 Fb^2/EJ$$

$$L_{GD}^{xo} = \int_0^b (1/2 x/b - 1/2 x^3/b^3) Fb 1/EJ dx = [1/4 x^2/b - 1/8 x^4/b^3]_0^b Fb 1/EJ$$

$$= (1/4 b - 1/8 b) Fb 1/EJ = 1/8 Fb^2/EJ$$

$$L_{DG}^{xo} = \int_0^b (x/b - 3/2 x^2/b^2 + 1/2 x^3/b^3) Fb 1/EJ dx = [1/2 x^2/b - 1/2 x^3/b^2 + 1/8 x^4/b^3]_0^b Fb 1/EJ$$

$$= (1/2 b - 1/2 b + 1/8 b) Fb 1/EJ = 1/8 Fb^2/EJ$$

$$L_{GA}^{xo} = \int_0^b (-1/4 + 1/2 x/b - 1/4 x^2/b^2) Fb 1/EJ dx = [-1/4 x + 1/4 x^2/b - 1/12 x^3/b^2]_0^b Fb 1/EJ$$

$$= (-1/4 b + 1/4 b - 1/12 b) Fb 1/EJ = -1/12 Fb^2/EJ$$

$$L_{AG}^{xo} = \int_0^b (-1/4 x^2/b^2) Fb 1/EJ dx = [-1/12 x^3/b^2]_0^b Fb 1/EJ$$

$$= (-1/12 b) Fb 1/EJ = -1/12 Fb^2/EJ$$

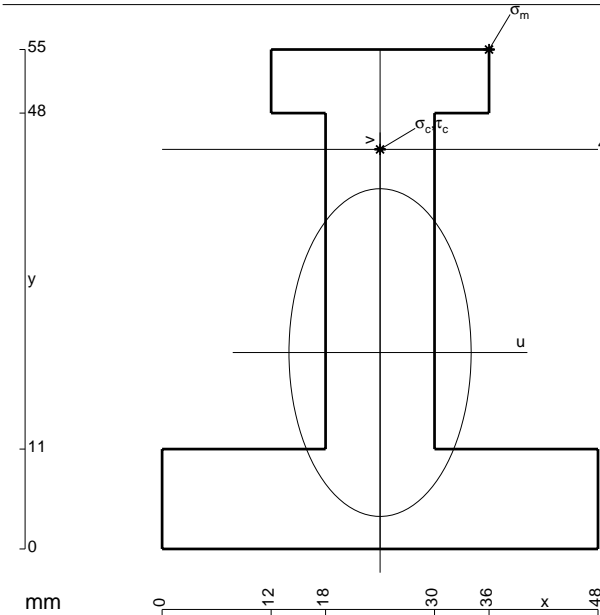

$$A = 1140. \text{ mm}^2$$

$$J_u = 371429. \text{ mm}^4$$

$$J_v = 114768. \text{ mm}^4$$

$$y_g = 21.63 \text{ mm}$$

$$N = -2060. \text{ N}$$

$$T_y = -5150. \text{ N}$$

$$M_x = -2348400. \text{ Nmm}$$

$$x_m = 36. \text{ mm}$$

$$y_m = 55. \text{ mm}$$

$$u_m = 12. \text{ mm}$$

$$v_m = 33.37 \text{ mm}$$

$$\sigma_m = N/A - Mv/J_u = 209.2 \text{ N/mm}^2$$

$$x_c = 24. \text{ mm}$$

$$y_c = 44. \text{ mm}$$

$$v_c = 22.37 \text{ mm}$$

$$\sigma_c = N/A - Mv/J_u = 139.7 \text{ N/mm}^2$$

$$\tau_c = 7.151 \text{ N/mm}^2$$

$$\sigma_o = \sqrt{\sigma^2 + 3\tau^2} = 140.2 \text{ N/mm}^2$$

$$S = 6189. \text{ mm}^3$$

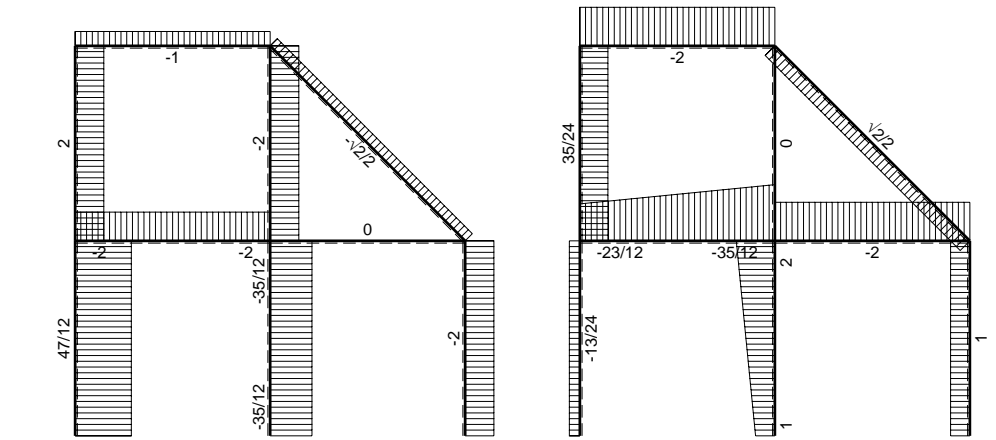
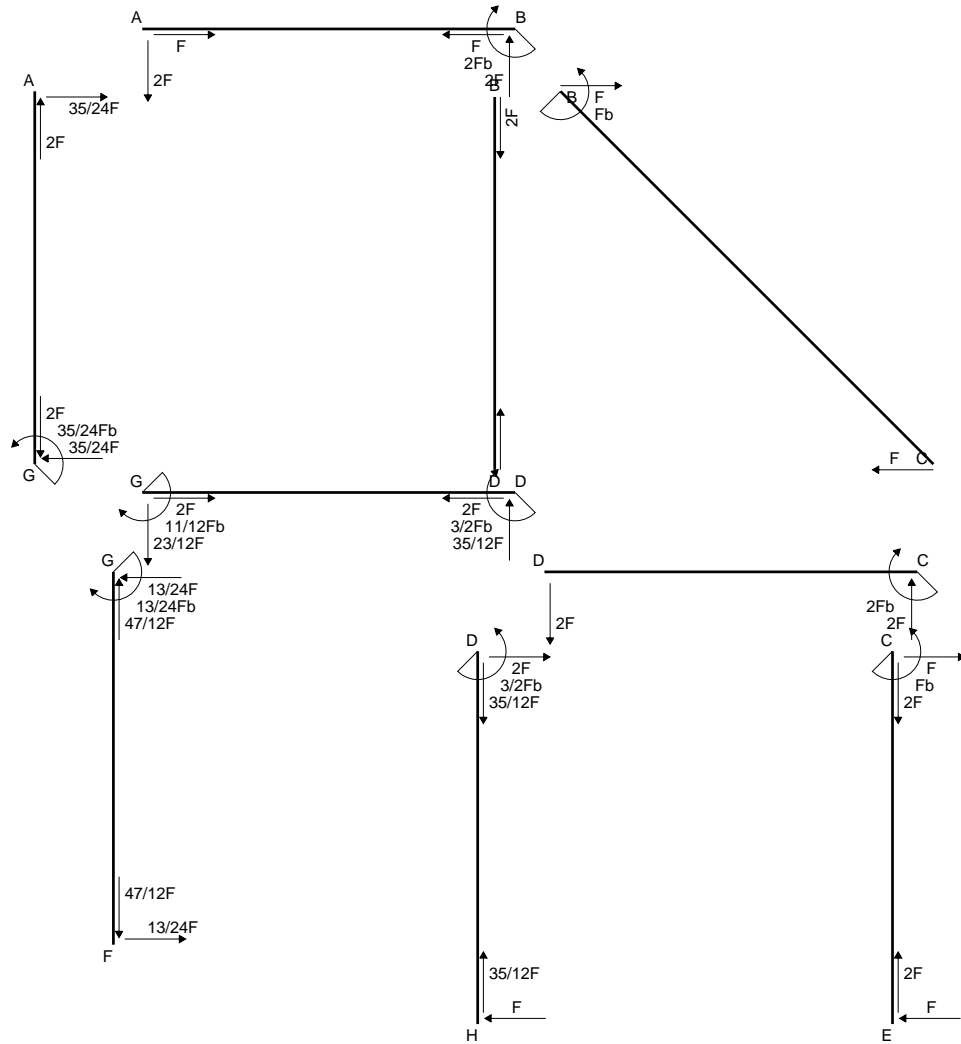

← (+) → F

↑ (+) ↓ F

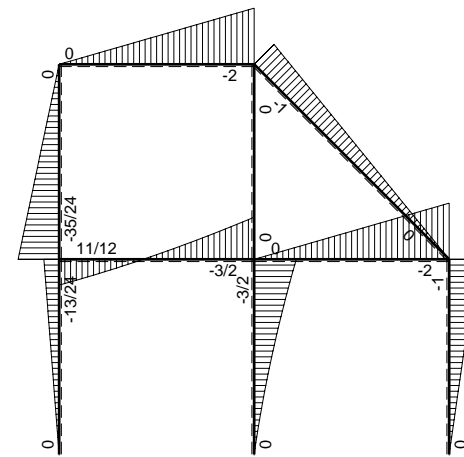

↺ (+) ↻ Fb

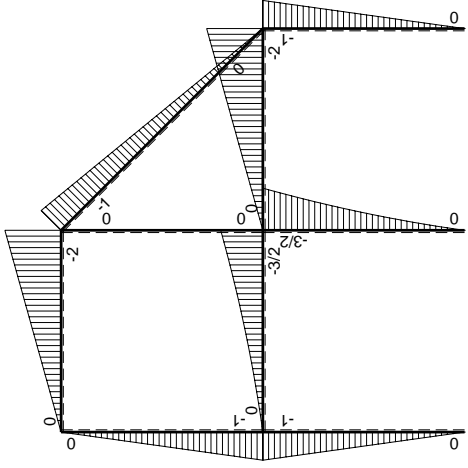
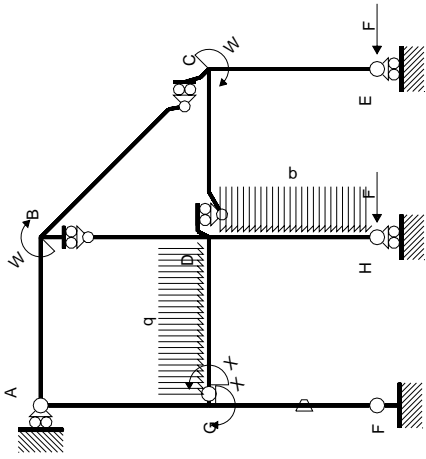

Schema di calcolo iperstatico

M_0 flessione da carichi assegnati

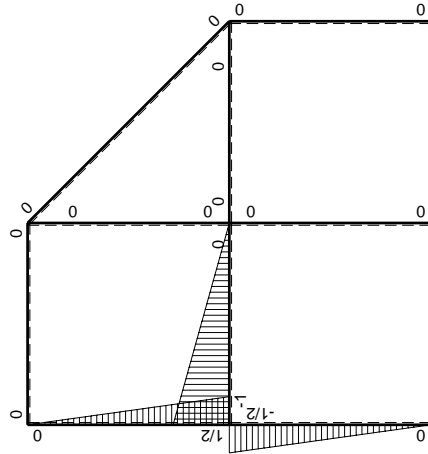

M_x flessione da iperstatica $X=1$

Quadro contributi PLV per iperstatica $X=W_{GD}$

→	$M_x(x)$	$M_o(x)$	θ	$M_x M_o$	$M_x \theta$	$M_x M_x$	$\int M_x(M_o/EJ+\theta)dx$	$\int X M_x M_x / EJ dx$	
AB b	0	-2Fx	0	0	0	0	0+0	0	
BA b	0	2Fb-2Fx	0	0	0	0	0	0	
BC $\sqrt{2}b$	0	-Fb+ $\sqrt{2}/2Fx$	0	0	0	0	0	0	
BD b	0	0	0	0	0	0	0+0	0	
DB b	0	0	0	0	0	0	0	0	
DC b	0	-2Fx	0	0	0	0	0+0	0	
CD b	0	2Fb-2Fx	0	0	0	0	0	0	
CE b	0	-Fb+Fx	0	0	0	0	0+0	0	
EC b	0	Fx	0	0	0	0	0	0	
FG b	-1/2x/b	-Fx	-Fb/EJ	1/2Fx ² /b	1/2Fx/EJ	1/4x ² /b ²	(1/6+1/4)Fb ² /EJ	1/12Xb/EJ	
GF b	1/2-1/2x/b	Fb-Fx	Fb/EJ	1/2Fb-Fx+1/2Fx ² /b	1/2Fb/EJ-1/2Fx/EJ	1/4-1/2x/b+1/4x ² /b ²			
GD b	-1+x/b	-Fx-1/2qx ²	0	Fx-1/2Fx ² /b-1/2qx ³ /b	0	1-2x/b+x ² /b ²	(5/24+0)Fb ² /EJ	1/3Xb/EJ	
DG b	x/b	3/2Fb-2Fx+1/2qx ²	0	3/2Fx-2Fx ² /b+1/2qx ³ /b	0	x ² /b ²			
DH b	0	-3/2Fb+2Fx-1/2qx ²	0	0	0	0	0+0	0	
HD b	0	Fx+1/2qx ²	0	0	0	0			
GA b	1/2-1/2x/b	-Fb+Fx	0	-1/2Fb+Fx-1/2Fx ² /b	0	1/4-1/2x/b+1/4x ² /b ²	(-1/6+0)Fb ² /EJ	1/12Xb/EJ	
AG b	-1/2x/b	Fx	0	-1/2Fx ² /b	0	1/4x ² /b ²			
	totali							11/24Fb ² /EJ	1/2Xb/EJ
	iperstatica $X=W_{GD}$							-11/12Fb	

Sviluppi di calcolo iperstatica

$$L_{FG}^{xx} = \int_0^b (1/4 x^2/b^2) 1/EJ dx = [1/12 x^3/b^2]_0^b 1/EJ$$

$$= (1/12 b) 1/EJ = 1/12 b/EJ$$

$$L_{GF}^{xx} = \int_0^b (1/4 - 1/2 x/b + 1/4 x^2/b^2) 1/EJ dx = [1/4 x - 1/4 x^2/b + 1/12 x^3/b^2]_0^b 1/EJ$$

$$= (1/4 b - 1/4 b + 1/12 b) 1/EJ = 1/12 b/EJ$$

$$L_{GD}^{xx} = \int_0^b (1 - 2 x/b + x^2/b^2) 1/EJ dx = [x - x^2/b + 1/3 x^3/b^2]_0^b 1/EJ$$

$$= (b - b + 1/3 b) 1/EJ = 1/3 b/EJ$$

$$L_{DG}^{xx} = \int_0^b (x^2/b^2) 1/EJ dx = [1/3 x^3/b^2]_0^b 1/EJ$$

$$= (1/3 b) 1/EJ = 1/3 b/EJ$$

$$L_{GA}^{xx} = \int_0^b (1/4 - 1/2 x/b + 1/4 x^2/b^2) 1/EJ dx = [1/4 x - 1/4 x^2/b + 1/12 x^3/b^2]_0^b 1/EJ$$

$$= (1/4 b - 1/4 b + 1/12 b) 1/EJ = 1/12 b/EJ$$

$$L_{AG}^{xx} = \int_0^b (1/4 x^2/b^2) 1/EJ dx = [1/12 x^3/b^2]_0^b 1/EJ$$

$$= (1/12 b) 1/EJ = 1/12 b/EJ$$

$$L_{FG}^{xo} = \int_0^b (1/2 x^2/b^2) Fb 1/EJ dx + \int_0^b (1/2 x/b) \theta dx = [1/6 x^3/b^2]_0^b Fb 1/EJ + [1/4 x^2/b]_0^b \theta$$

$$= (1/6 b) Fb 1/EJ + (1/4 b) \theta = 5/12 Fb^2/EJ$$

$$L_{GF}^{xo} = \int_0^b (1/2 - x/b + 1/2 x^2/b^2) Fb 1/EJ dx + \int_0^b (-1/2 + 1/2 x/b) \theta dx$$

$$= [1/2 x - 1/2 x^2/b + 1/6 x^3/b^2]_0^b Fb 1/EJ + [-1/2 x + 1/4 x^2/b]_0^b \theta$$

$$= (1/2 b - 1/2 b + 1/6 b) Fb 1/EJ + (-1/2 b + 1/4 b) \theta = 5/12 Fb^2/EJ$$

$$L_{GD}^{xo} = \int_0^b (x/b - 1/2 x^2/b^2 - 1/2 x^3/b^3) Fb 1/EJ dx = [1/2 x^2/b - 1/6 x^3/b^2 - 1/8 x^4/b^3]_0^b Fb 1/EJ$$

$$= (1/2 b - 1/6 b - 1/8 b) Fb 1/EJ = 5/24 Fb^2/EJ$$

$$L_{DG}^{xo} = \int_0^b (3/2 x/b - 2 x^2/b^2 + 1/2 x^3/b^3) Fb 1/EJ dx = [3/4 x^2/b - 2/3 x^3/b^2 + 1/8 x^4/b^3]_0^b Fb 1/EJ$$

$$= (3/4 b - 2/3 b + 1/8 b) Fb 1/EJ = 5/24 Fb^2/EJ$$

$$L_{GA}^{xo} = \int_0^b (-1/2 + x/b - 1/2 x^2/b^2) Fb 1/EJ dx = [-1/2 x + 1/2 x^2/b - 1/6 x^3/b^2]_0^b Fb 1/EJ$$

$$= (-1/2 b + 1/2 b - 1/6 b) Fb 1/EJ = -1/6 Fb^2/EJ$$

$$L_{AG}^{xo} = \int_0^b (-1/2 x^2/b^2) Fb 1/EJ dx = [-1/6 x^3/b^2]_0^b Fb 1/EJ$$

$$= (-1/6 b) Fb 1/EJ = -1/6 Fb^2/EJ$$

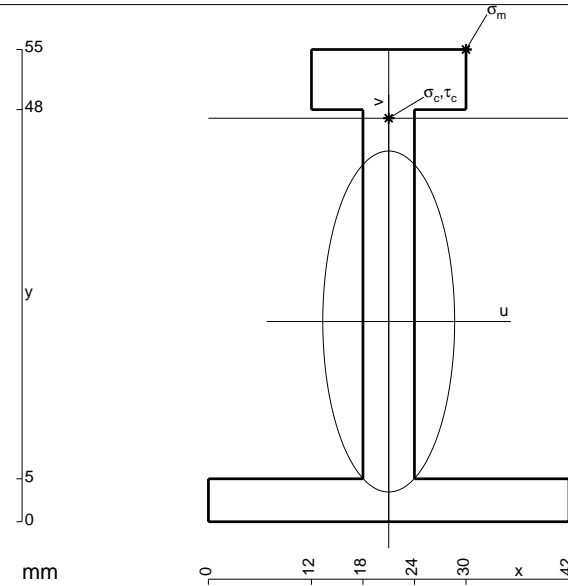

- A = 594. mm²
- J_u = 234402. mm⁴
- J_v = 35046. mm⁴
- y_g = 23.32 mm
- T_y = -2620. N
- M_x = -1624400. Nmm
- x_m = 30. mm
- y_m = 55. mm
- u_m = 9. mm
- v_m = 31.68 mm
- σ_m = -M_v/J_u = 219.6 N/mm²
- x_c = 21. mm
- y_c = 47. mm
- v_c = 23.68 mm
- σ_c = -M_v/J_u = 164.1 N/mm²
- τ_c = 6.885 N/mm²
- σ_q = √σ²+3τ² = 164.5 N/mm²
- S = 3696. mm³

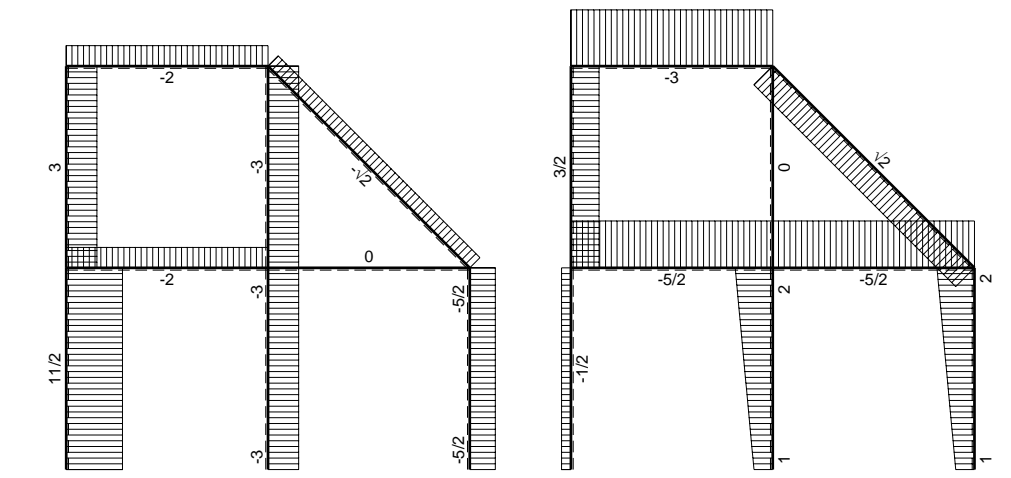
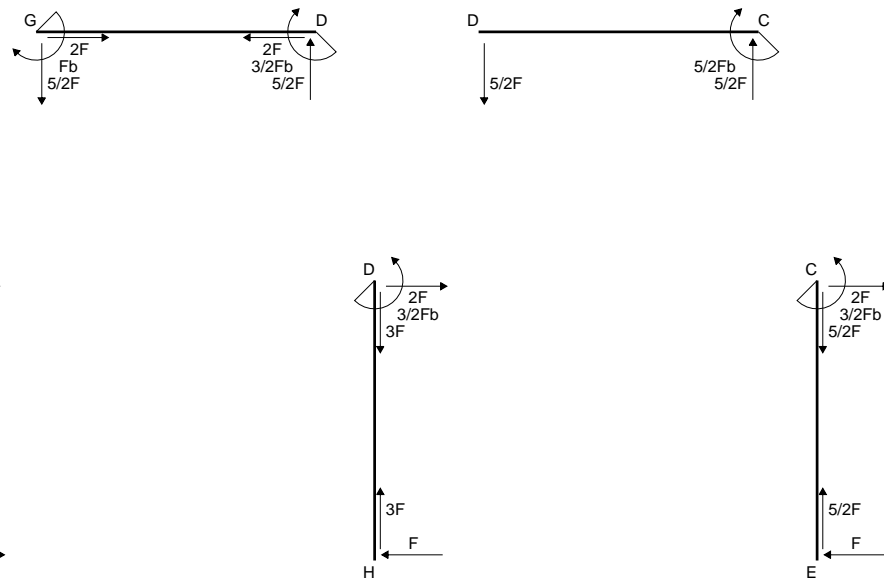
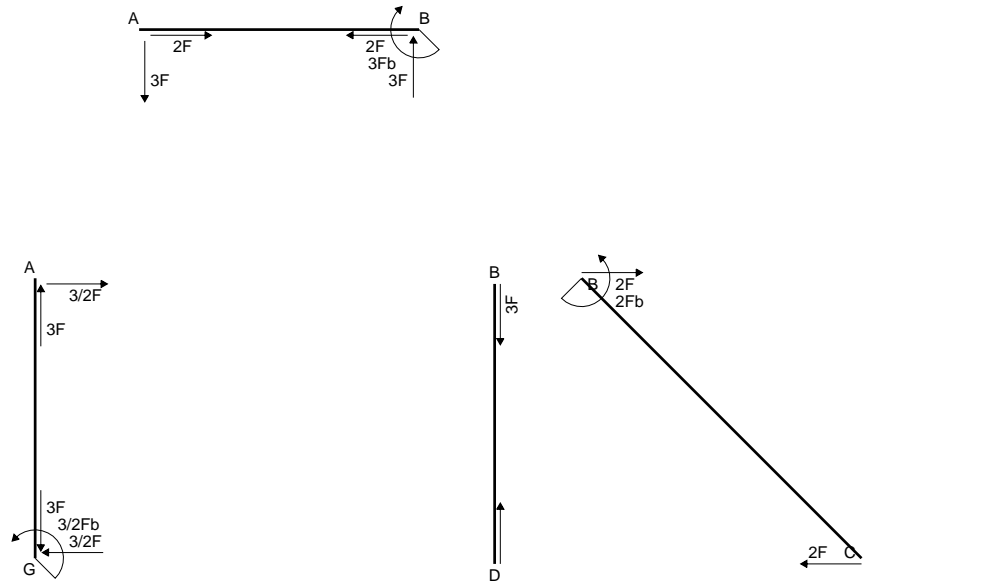

← ⊕ → F

↑ ⊕ ↓ F

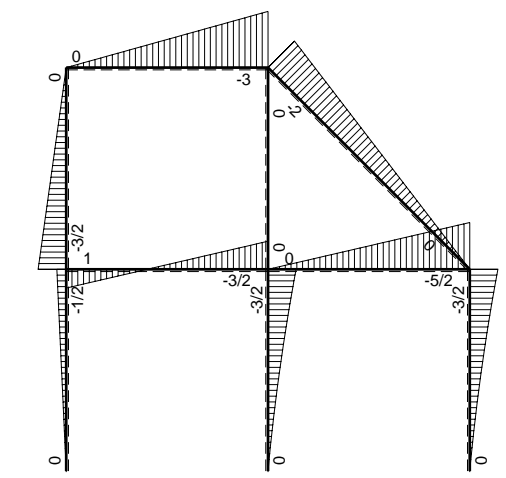

⊕ ⊖ Mb

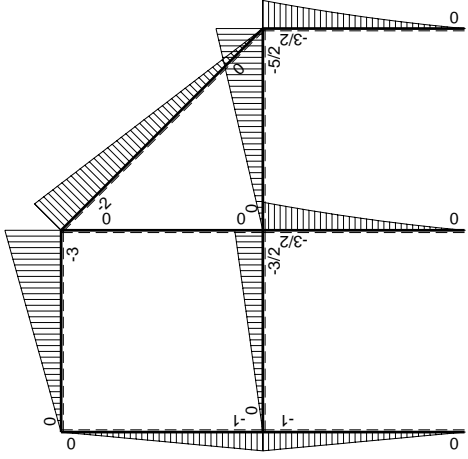
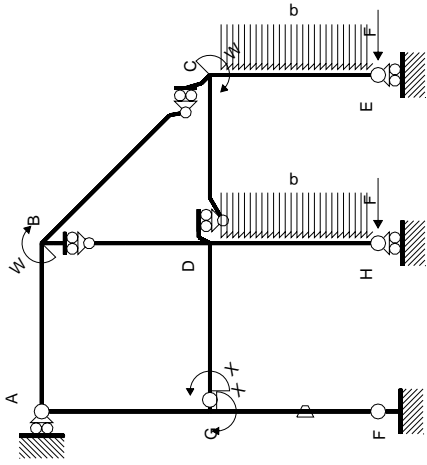

M_0 flessione da carichi assegnati

Schema di calcolo iperstatico

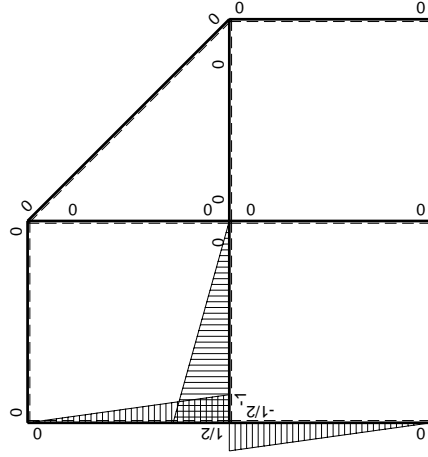

M_x flessione da iperstatica $X=1$

Quadro contributi PLV per iperstatica $X=W_{GD}$

→	$M_x(x)$	$M_o(x)$	θ	$M_x M_o$	$M_x \theta$	$M_x M_x$	$\int M_x(M_o/EJ+\theta)dx$	$\int X M_x M_x/EJ dx$	
AB b	0	-3Fx	0	0	0	0	0+0	0	
BA b	0	3Fb-3Fx	0	0	0	0	0	0	
BC $\sqrt{2}b$	0	-2Fb+ $\sqrt{2}Fx$	0	0	0	0	0	0	
BD b	0	0	0	0	0	0	0+0	0	
DB b	0	0	0	0	0	0	0	0	
DC b	0	-5/2Fx	0	0	0	0	0+0	0	
CD b	0	5/2Fb-5/2Fx	0	0	0	0	0	0	
CE b	0	-3/2Fb+2Fx-1/2qx ²	0	0	0	0	0+0	0	
EC b	0	Fx+1/2qx ²	0	0	0	0	0	0	
FG b	-1/2x/b	-Fx	-Fb/EJ	1/2Fx ² /b	1/2Fx/EJ	1/4x ² /b ²	(1/6+1/4)Fb ² /EJ	1/12Xb/EJ	
GF b	1/2-1/2x/b	Fb-Fx	Fb/EJ	1/2Fb-Fx+1/2Fx ² /b	1/2Fb/EJ-1/2Fx/EJ	1/4-1/2x/b+1/4x ² /b ²			
GD b	-1+x/b	-3/2Fx	0	3/2Fx-3/2Fx ² /b	0	1-2x/b+x ² /b ²	(1/4+0)Fb ² /EJ	1/3Xb/EJ	
DG b	x/b	3/2Fb-3/2Fx	0	3/2Fx-3/2Fx ² /b	0	x ² /b ²			
DH b	0	-3/2Fb+2Fx-1/2qx ²	0	0	0	0	0+0	0	
HD b	0	Fx+1/2qx ²	0	0	0	0	0	0	
GA b	1/2-1/2x/b	-Fb+Fx	0	-1/2Fb+Fx-1/2Fx ² /b	0	1/4-1/2x/b+1/4x ² /b ²	(-1/6+0)Fb ² /EJ	1/12Xb/EJ	
AG b	-1/2x/b	Fx	0	-1/2Fx ² /b	0	1/4x ² /b ²			
	totali							1/2Fb ² /EJ	1/2Xb/EJ
	iperstatica $X=W_{GD}$							-Fb	

Sviluppi di calcolo iperstatica

$$L_{FG}^{xx} = \int_0^b (1/4 x^2/b^2) 1/EJ dx = [1/12 x^3/b^2]_0^b 1/EJ$$

$$= (1/12 b) 1/EJ = 1/12 b/EJ$$

$$L_{GF}^{xx} = \int_0^b (1/4 - 1/2 x/b + 1/4 x^2/b^2) 1/EJ dx = [1/4 x - 1/4 x^2/b + 1/12 x^3/b^2]_0^b 1/EJ$$

$$= (1/4 b - 1/4 b + 1/12 b) 1/EJ = 1/12 b/EJ$$

$$L_{GD}^{xx} = \int_0^b (1 - 2 x/b + x^2/b^2) 1/EJ dx = [x - x^2/b + 1/3 x^3/b^2]_0^b 1/EJ$$

$$= (b - b + 1/3 b) 1/EJ = 1/3 b/EJ$$

$$L_{DG}^{xx} = \int_0^b (x^2/b^2) 1/EJ dx = [1/3 x^3/b^2]_0^b 1/EJ$$

$$= (1/3 b) 1/EJ = 1/3 b/EJ$$

$$L_{GA}^{xx} = \int_0^b (1/4 - 1/2 x/b + 1/4 x^2/b^2) 1/EJ dx = [1/4 x - 1/4 x^2/b + 1/12 x^3/b^2]_0^b 1/EJ$$

$$= (1/4 b - 1/4 b + 1/12 b) 1/EJ = 1/12 b/EJ$$

$$L_{AG}^{xx} = \int_0^b (1/4 x^2/b^2) 1/EJ dx = [1/12 x^3/b^2]_0^b 1/EJ$$

$$= (1/12 b) 1/EJ = 1/12 b/EJ$$

$$L_{FG}^{xo} = \int_0^b (1/2 x^2/b^2) Fb 1/EJ dx + \int_0^b (1/2 x/b) \theta dx = [1/6 x^3/b^2]_0^b Fb 1/EJ + [1/4 x^2/b]_0^b \theta$$

$$= (1/6 b) Fb 1/EJ + (1/4 b) \theta = 5/12 Fb^2/EJ$$

$$L_{GF}^{xo} = \int_0^b (1/2 - x/b + 1/2 x^2/b^2) Fb 1/EJ dx + \int_0^b (-1/2 + 1/2 x/b) \theta dx$$

$$= [1/2 x - 1/2 x^2/b + 1/6 x^3/b^2]_0^b Fb 1/EJ + [-1/2 x + 1/4 x^2/b]_0^b \theta$$

$$= (1/2 b - 1/2 b + 1/6 b) Fb 1/EJ + (-1/2 b + 1/4 b) \theta = 5/12 Fb^2/EJ$$

$$L_{GD}^{xo} = \int_0^b (3/2 x/b - 3/2 x^2/b^2) Fb 1/EJ dx = [3/4 x^2/b - 1/2 x^3/b^2]_0^b Fb 1/EJ$$

$$= (3/4 b - 1/2 b) Fb 1/EJ = 1/4 Fb^2/EJ$$

$$L_{DG}^{xo} = \int_0^b (3/2 x/b - 3/2 x^2/b^2) Fb 1/EJ dx = [3/4 x^2/b - 1/2 x^3/b^2]_0^b Fb 1/EJ$$

$$= (3/4 b - 1/2 b) Fb 1/EJ = 1/4 Fb^2/EJ$$

$$L_{GA}^{xo} = \int_0^b (-1/2 + x/b - 1/2 x^2/b^2) Fb 1/EJ dx = [-1/2 x + 1/2 x^2/b - 1/6 x^3/b^2]_0^b Fb 1/EJ$$

$$= (-1/2 b + 1/2 b - 1/6 b) Fb 1/EJ = -1/6 Fb^2/EJ$$

$$L_{AG}^{xo} = \int_0^b (-1/2 x^2/b^2) Fb 1/EJ dx = [-1/6 x^3/b^2]_0^b Fb 1/EJ$$

$$= (-1/6 b) Fb 1/EJ = -1/6 Fb^2/EJ$$

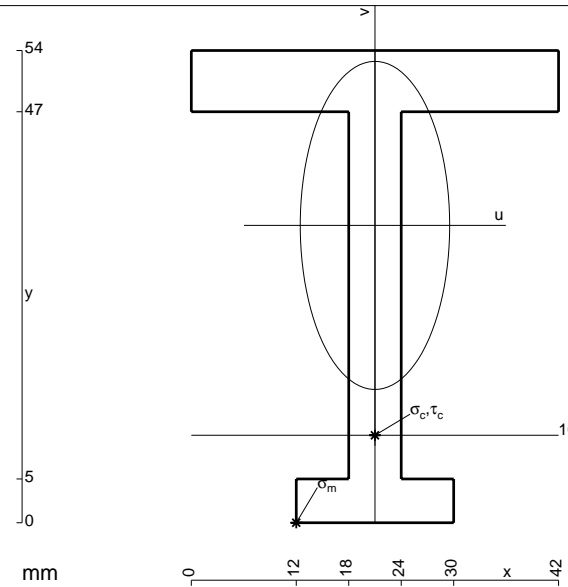

- A = 636. mm²
- J_u = 223904. mm⁴
- J_v = 46404. mm⁴
- y_g = 34. mm
- N = -1500. N
- T_y = -2250. N
- M_x = -1485000. Nmm
- x_m = 12. mm
- u_m = -9. mm
- v_m = -34. mm
- σ_m = N/A - Mv/J_u = -227.9 N/mm²
- x_c = 21. mm
- y_c = 10. mm
- v_c = -24. mm
- σ_c = N/A - Mv/J_u = -161.5 N/mm²
- τ_c = 6.08 N/mm²
- σ_q = √(σ² + 3τ²) = 161.9 N/mm²
- S = 3630. mm³

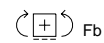
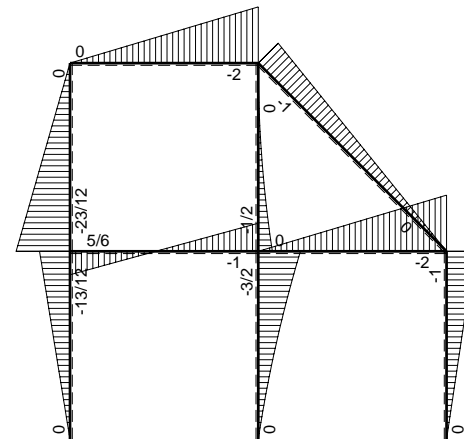
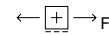
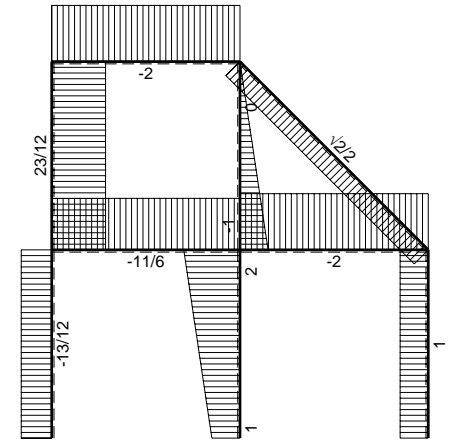
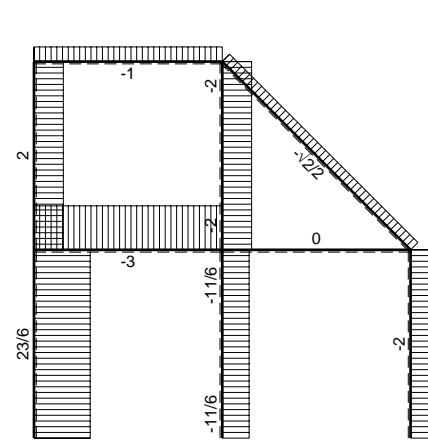
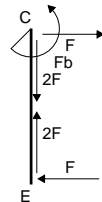
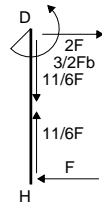
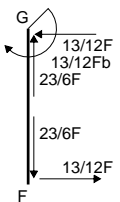
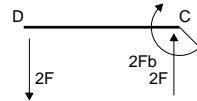
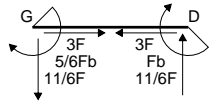
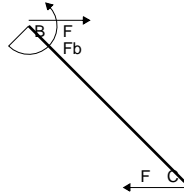
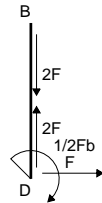
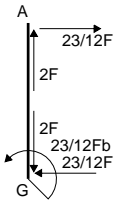
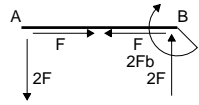

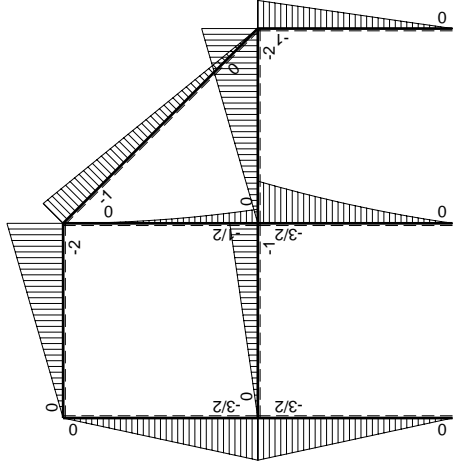
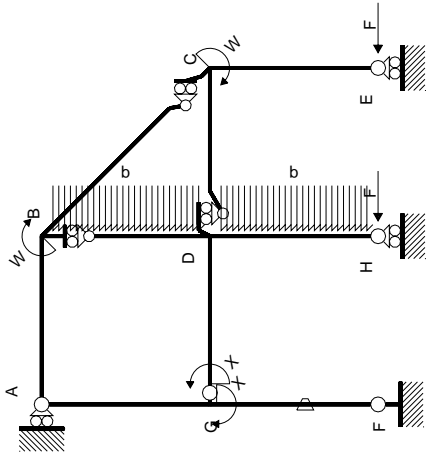

Schema di calcolo iperstatico

M_0 flessione da carichi assegnati

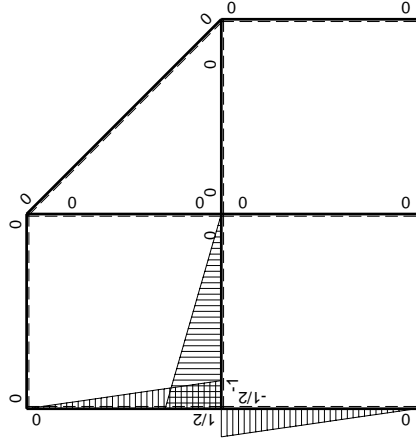

M_x flessione da iperstatica $X=1$

Quadro contributi PLV per iperstatica $X=W_{GD}$

→	$M_x(x)$	$M_o(x)$	θ	$M_x M_o$	$M_x \theta$	$M_x M_x$	$\int M_x(M_o/EJ+\theta)dx$	$\int X M_x M_x/EJdx$	
AB b	0	-2Fx	0	0	0	0	0+0	0	
BA b	0	2Fb-2Fx	0	0	0	0			
BC $\sqrt{2}b$	0	-Fb+ $\sqrt{2}/2Fx$	0	0	0	0	0	0	
BD b	0	-1/2qx ²	0	0	0	0	0+0	0	
DB b	0	1/2Fb-Fx+1/2qx ²	0	0	0	0			
DC b	0	-2Fx	0	0	0	0	0+0	0	
CD b	0	2Fb-2Fx	0	0	0	0			
CE b	0	-Fb+Fx	0	0	0	0	0+0	0	
EC b	0	Fx	0	0	0	0			
FG b	-1/2x/b	-3/2Fx	-Fb/EJ	3/4Fx ² /b	1/2Fx/EJ	1/4x ² /b ²	(1/4+1/4)Fb ² /EJ	1/12Xb/EJ	
GF b	1/2-1/2x/b	3/2Fb-3/2Fx	Fb/EJ	3/4Fb-3/2Fx+3/4Fx ² /b	1/2Fb/EJ-1/2Fx/EJ	1/4-1/2x/b+1/4x ² /b ²			
GD b	-1+x/b	-Fx	0	Fx-Fx ² /b	0	1-2x/b+x ² /b ²	(1/6+0)Fb ² /EJ	1/3Xb/EJ	
DG b	x/b	Fb-Fx	0	Fx-Fx ² /b	0	x ² /b ²			
DH b	0	-3/2Fb+2Fx-1/2qx ²	0	0	0	0	0+0	0	
HD b	0	Fx+1/2qx ²	0	0	0	0			
GA b	1/2-1/2x/b	-3/2Fb+3/2Fx	0	-3/4Fb+3/2Fx-3/4Fx ² /b	0	1/4-1/2x/b+1/4x ² /b ²	(-1/4+0)Fb ² /EJ	1/12Xb/EJ	
AG b	-1/2x/b	3/2Fx	0	-3/4Fx ² /b	0	1/4x ² /b ²			
	totali							5/12Fb ² /EJ	1/2Xb/EJ
	iperstatica $X=W_{GD}$							-5/6Fb	

Sviluppi di calcolo iperstatica

$$L_{FG}^{xx} = \int_0^b (1/4 x^2/b^2) 1/EJ dx = [1/12 x^3/b^2]_0^b 1/EJ$$

$$= (1/12 b) 1/EJ = 1/12 b/EJ$$

$$L_{GF}^{xx} = \int_0^b (1/4 - 1/2 x/b + 1/4 x^2/b^2) 1/EJ dx = [1/4 x - 1/4 x^2/b + 1/12 x^3/b^2]_0^b 1/EJ$$

$$= (1/4 b - 1/4 b + 1/12 b) 1/EJ = 1/12 b/EJ$$

$$L_{GD}^{xx} = \int_0^b (1 - 2 x/b + x^2/b^2) 1/EJ dx = [x - x^2/b + 1/3 x^3/b^2]_0^b 1/EJ$$

$$= (b - b + 1/3 b) 1/EJ = 1/3 b/EJ$$

$$L_{DG}^{xx} = \int_0^b (x^2/b^2) 1/EJ dx = [1/3 x^3/b^2]_0^b 1/EJ$$

$$= (1/3 b) 1/EJ = 1/3 b/EJ$$

$$L_{GA}^{xx} = \int_0^b (1/4 - 1/2 x/b + 1/4 x^2/b^2) 1/EJ dx = [1/4 x - 1/4 x^2/b + 1/12 x^3/b^2]_0^b 1/EJ$$

$$= (1/4 b - 1/4 b + 1/12 b) 1/EJ = 1/12 b/EJ$$

$$L_{AG}^{xx} = \int_0^b (1/4 x^2/b^2) 1/EJ dx = [1/12 x^3/b^2]_0^b 1/EJ$$

$$= (1/12 b) 1/EJ = 1/12 b/EJ$$

$$L_{FG}^{xo} = \int_0^b (3/4 x^2/b^2) Fb 1/EJ dx + \int_0^b (1/2 x/b) \theta dx = [1/4 x^3/b^2]_0^b Fb 1/EJ + [1/4 x^2/b]_0^b \theta$$

$$= (1/4 b) Fb 1/EJ + (1/4 b) \theta = 1/2 Fb^2/EJ$$

$$L_{GF}^{xo} = \int_0^b (3/4 - 3/2 x/b + 3/4 x^2/b^2) Fb 1/EJ dx + \int_0^b (-1/2 + 1/2 x/b) \theta dx$$

$$= [3/4 x - 3/4 x^2/b + 1/4 x^3/b^2]_0^b Fb 1/EJ + [-1/2 x + 1/4 x^2/b]_0^b \theta$$

$$= (3/4 b - 3/4 b + 1/4 b) Fb 1/EJ + (-1/2 b + 1/4 b) \theta = 1/2 Fb^2/EJ$$

$$L_{GD}^{xo} = \int_0^b (x/b - x^2/b^2) Fb 1/EJ dx = [1/2 x^2/b - 1/3 x^3/b^2]_0^b Fb 1/EJ$$

$$= (1/2 b - 1/3 b) Fb 1/EJ = 1/6 Fb^2/EJ$$

$$L_{DG}^{xo} = \int_0^b (x/b - x^2/b^2) Fb 1/EJ dx = [1/2 x^2/b - 1/3 x^3/b^2]_0^b Fb 1/EJ$$

$$= (1/2 b - 1/3 b) Fb 1/EJ = 1/6 Fb^2/EJ$$

$$L_{GA}^{xo} = \int_0^b (-3/4 + 3/2 x/b - 3/4 x^2/b^2) Fb 1/EJ dx = [-3/4 x + 3/4 x^2/b - 1/4 x^3/b^2]_0^b Fb 1/EJ$$

$$= (-3/4 b + 3/4 b - 1/4 b) Fb 1/EJ = -1/4 Fb^2/EJ$$

$$L_{AG}^{xo} = \int_0^b (-3/4 x^2/b^2) Fb 1/EJ dx = [-1/4 x^3/b^2]_0^b Fb 1/EJ$$

$$= (-1/4 b) Fb 1/EJ = -1/4 Fb^2/EJ$$

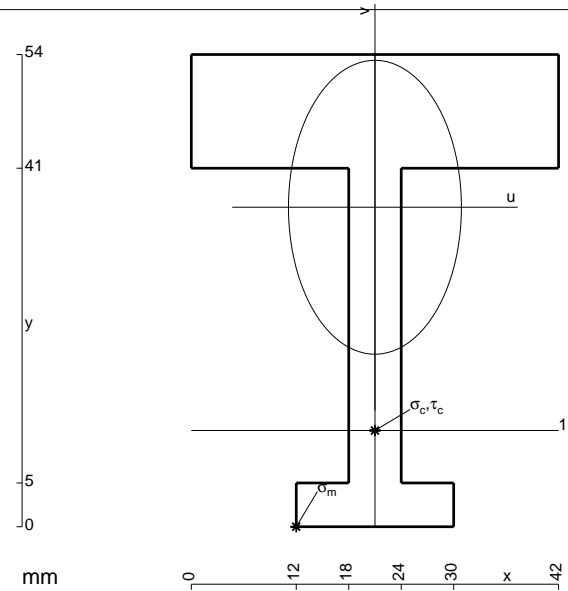

- A = 852. mm²
- J_u = 240676. mm⁴
- J_v = 83340. mm⁴
- y_g = 36.54 mm
- N = -1100. N
- T_y = -2200. N
- M_x = -1562000. Nmm
- x_m = 12. mm
- u_m = -9. mm
- v_m = -36.54 mm
- σ_m = N/A - Mv/J_u = -238.4 N/mm²
- x_c = 21. mm
- y_c = 11. mm
- v_c = -25.54 mm
- σ_c = N/A - Mv/J_u = -167. N/mm²
- τ_c = 6.232 N/mm²
- σ_q = √(σ² + 3τ²) = 167.4 N/mm²
- S = 4090. mm³

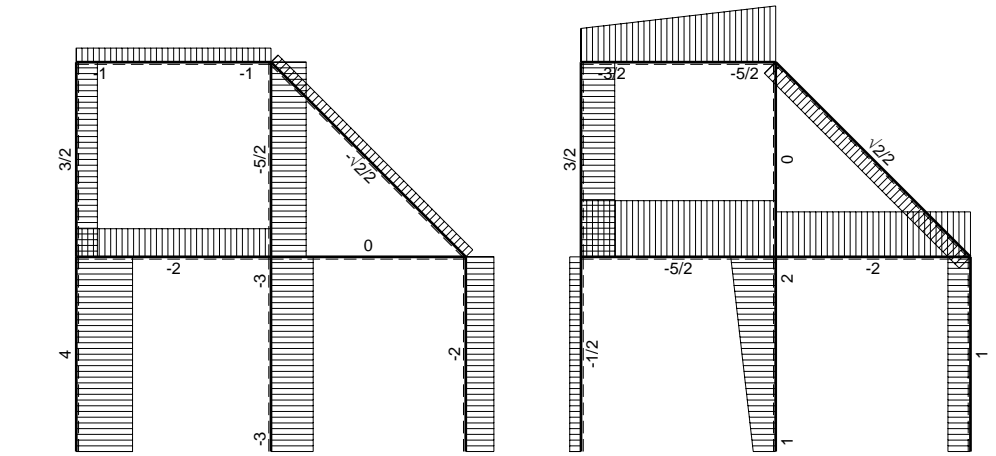
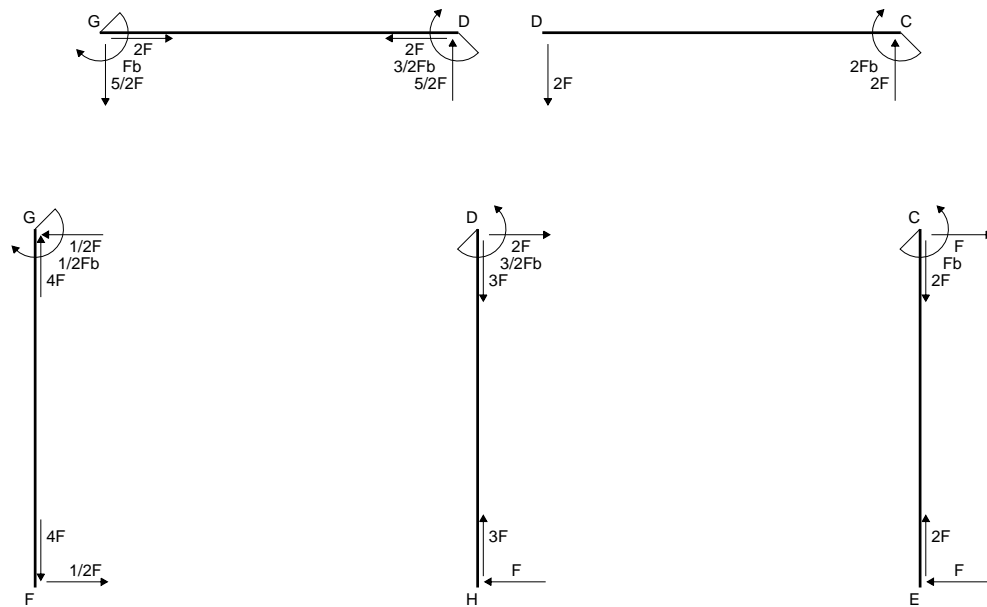
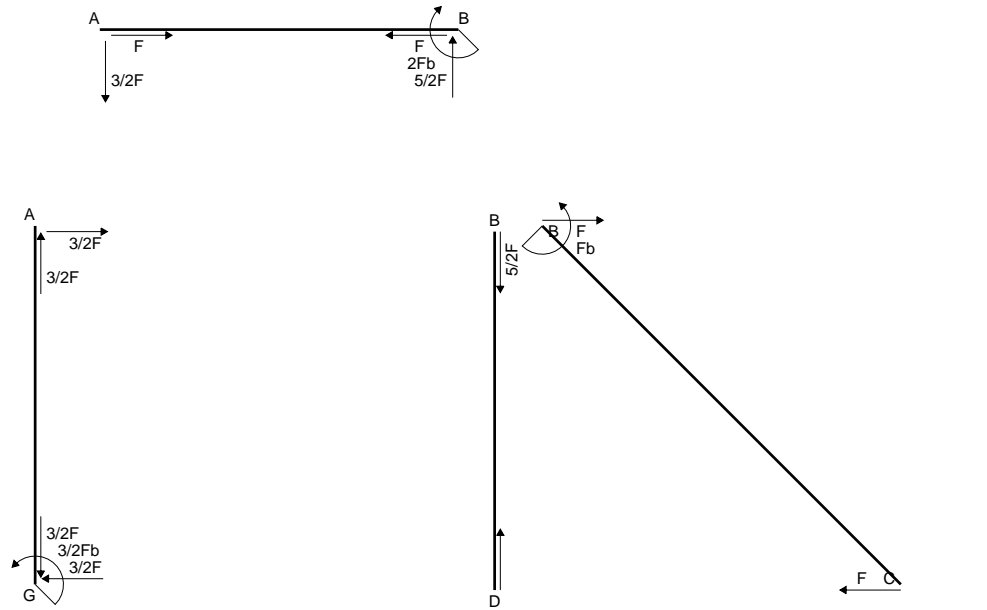

← (+) → F

↑ (+) ↓ F_b

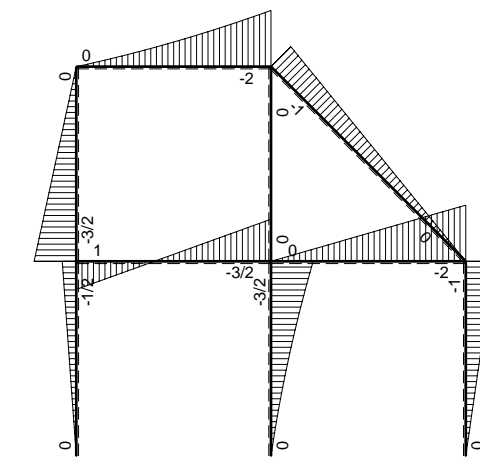

↑ (+) ↓ F_b

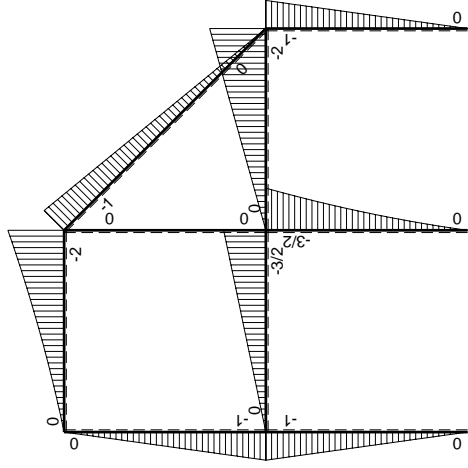
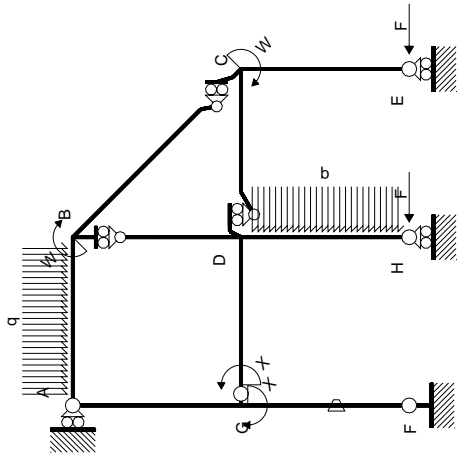

Schema di calcolo iperstatico

M_0 flessione da carichi assegnati

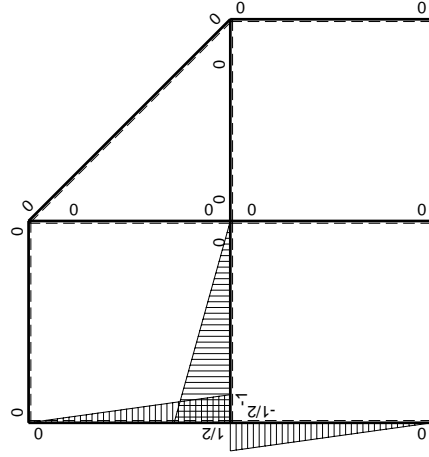

M_x flessione da iperstatica $X=1$

Quadro contributi PLV per iperstatica $X=W_{GD}$

→	$M_x(x)$	$M_o(x)$	θ	$M_x M_o$	$M_x \theta$	$M_x M_x$	$\int M_x(M_o/EJ+\theta)dx$	$\int X M_x M_x/EJ dx$	
AB b	0	$-3/2Fx-1/2qx^2$	0	0	0	0	0+0	0	
BA b	0	$2Fb-5/2Fx+1/2qx^2$	0	0	0	0	0	0	
BC $\sqrt{2}b$	0	$-Fb+\sqrt{2}/2Fx$	0	0	0	0	0	0	
BD b	0	0	0	0	0	0	0+0	0	
DB b	0	0	0	0	0	0	0	0	
DC b	0	$-2Fx$	0	0	0	0	0+0	0	
CD b	0	$2Fb-2Fx$	0	0	0	0	0	0	
CE b	0	$-Fb+Fx$	0	0	0	0	0+0	0	
EC b	0	Fx	0	0	0	0	0	0	
FG b	$-1/2x/b$	$-Fx$	$-Fb/EJ$	$1/2Fx^2/b$	$1/2Fx/EJ$	$1/4x^2/b^2$	$(1/6+1/4)Fb^2/EJ$	$1/12Xb/EJ$	
GF b	$1/2-1/2x/b$	$Fb-Fx$	Fb/EJ	$1/2Fb-Fx+1/2Fx^2/b$	$1/2Fb/EJ-1/2Fx/EJ$	$1/4-1/2x/b+1/4x^2/b^2$			
GD b	$-1+x/b$	$-3/2Fx$	0	$3/2Fx-3/2Fx^2/b$	0	$1-2x/b+x^2/b^2$	$(1/4+0)Fb^2/EJ$	$1/3Xb/EJ$	
DG b	x/b	$3/2Fb-3/2Fx$	0	$3/2Fx-3/2Fx^2/b$	0	x^2/b^2			
DH b	0	$-3/2Fb+2Fx-1/2qx^2$	0	0	0	0	0+0	0	
HD b	0	$Fx+1/2qx^2$	0	0	0	0	0	0	
GA b	$1/2-1/2x/b$	$-Fb+Fx$	0	$-1/2Fb+Fx-1/2Fx^2/b$	0	$1/4-1/2x/b+1/4x^2/b^2$	$(-1/6+0)Fb^2/EJ$	$1/12Xb/EJ$	
AG b	$-1/2x/b$	Fx	0	$-1/2Fx^2/b$	0	$1/4x^2/b^2$			
	totali							$1/2Fb^2/EJ$	$1/2Xb/EJ$
	iperstatica $X=W_{GD}$							$-Fb$	

Sviluppi di calcolo iperstatica

$$L_{FG}^{xx} = \int_0^b (1/4 x^2/b^2) 1/EJ dx = [1/12 x^3/b^2]_0^b 1/EJ$$

$$= (1/12 b) 1/EJ = 1/12 b/EJ$$

$$L_{GF}^{xx} = \int_0^b (1/4 - 1/2 x/b + 1/4 x^2/b^2) 1/EJ dx = [1/4 x - 1/4 x^2/b + 1/12 x^3/b^2]_0^b 1/EJ$$

$$= (1/4 b - 1/4 b + 1/12 b) 1/EJ = 1/12 b/EJ$$

$$L_{GD}^{xx} = \int_0^b (1 - 2 x/b + x^2/b^2) 1/EJ dx = [x - x^2/b + 1/3 x^3/b^2]_0^b 1/EJ$$

$$= (b - b + 1/3 b) 1/EJ = 1/3 b/EJ$$

$$L_{DG}^{xx} = \int_0^b (x^2/b^2) 1/EJ dx = [1/3 x^3/b^2]_0^b 1/EJ$$

$$= (1/3 b) 1/EJ = 1/3 b/EJ$$

$$L_{GA}^{xx} = \int_0^b (1/4 - 1/2 x/b + 1/4 x^2/b^2) 1/EJ dx = [1/4 x - 1/4 x^2/b + 1/12 x^3/b^2]_0^b 1/EJ$$

$$= (1/4 b - 1/4 b + 1/12 b) 1/EJ = 1/12 b/EJ$$

$$L_{AG}^{xx} = \int_0^b (1/4 x^2/b^2) 1/EJ dx = [1/12 x^3/b^2]_0^b 1/EJ$$

$$= (1/12 b) 1/EJ = 1/12 b/EJ$$

$$L_{FG}^{xo} = \int_0^b (1/2 x^2/b^2) Fb 1/EJ dx + \int_0^b (1/2 x/b) \theta dx = [1/6 x^3/b^2]_0^b Fb 1/EJ + [1/4 x^2/b]_0^b \theta$$

$$= (1/6 b) Fb 1/EJ + (1/4 b) \theta = 5/12 Fb^2/EJ$$

$$L_{GF}^{xo} = \int_0^b (1/2 - x/b + 1/2 x^2/b^2) Fb 1/EJ dx + \int_0^b (-1/2 + 1/2 x/b) \theta dx$$

$$= [1/2 x - 1/2 x^2/b + 1/6 x^3/b^2]_0^b Fb 1/EJ + [-1/2 x + 1/4 x^2/b]_0^b \theta$$

$$= (1/2 b - 1/2 b + 1/6 b) Fb 1/EJ + (-1/2 b + 1/4 b) \theta = 5/12 Fb^2/EJ$$

$$L_{GD}^{xo} = \int_0^b (3/2 x/b - 3/2 x^2/b^2) Fb 1/EJ dx = [3/4 x^2/b - 1/2 x^3/b^2]_0^b Fb 1/EJ$$

$$= (3/4 b - 1/2 b) Fb 1/EJ = 1/4 Fb^2/EJ$$

$$L_{DG}^{xo} = \int_0^b (3/2 x/b - 3/2 x^2/b^2) Fb 1/EJ dx = [3/4 x^2/b - 1/2 x^3/b^2]_0^b Fb 1/EJ$$

$$= (3/4 b - 1/2 b) Fb 1/EJ = 1/4 Fb^2/EJ$$

$$L_{GA}^{xo} = \int_0^b (-1/2 + x/b - 1/2 x^2/b^2) Fb 1/EJ dx = [-1/2 x + 1/2 x^2/b - 1/6 x^3/b^2]_0^b Fb 1/EJ$$

$$= (-1/2 b + 1/2 b - 1/6 b) Fb 1/EJ = -1/6 Fb^2/EJ$$

$$L_{AG}^{xo} = \int_0^b (-1/2 x^2/b^2) Fb 1/EJ dx = [-1/6 x^3/b^2]_0^b Fb 1/EJ$$

$$= (-1/6 b) Fb 1/EJ = -1/6 Fb^2/EJ$$

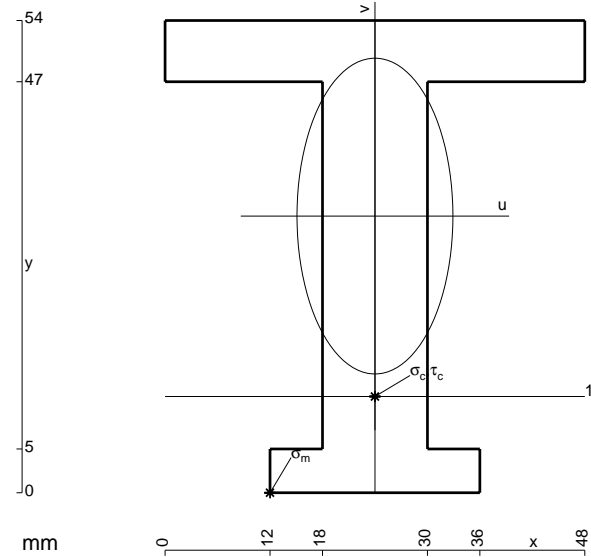

- A = 960. mm²
- J_u = 313154. mm⁴
- J_v = 76320. mm⁴
- y_g = 31.64 mm
- N = -1290. N
- T_y = -3225. N
- M_x = -1960800. Nmm
- x_m = 12. mm
- u_m = -12. mm
- v_m = -31.64 mm
- σ_m = N/A-Mv/J_u = -199.4 N/mm²
- x_c = 24. mm
- y_c = 11. mm
- v_c = -20.64 mm
- σ_c = N/A-Mv/J_u = -130.6 N/mm²
- τ_c = 4.461 N/mm²
- σ_q = √(σ²+3τ²) = 130.8 N/mm²
- S = 5198. mm³

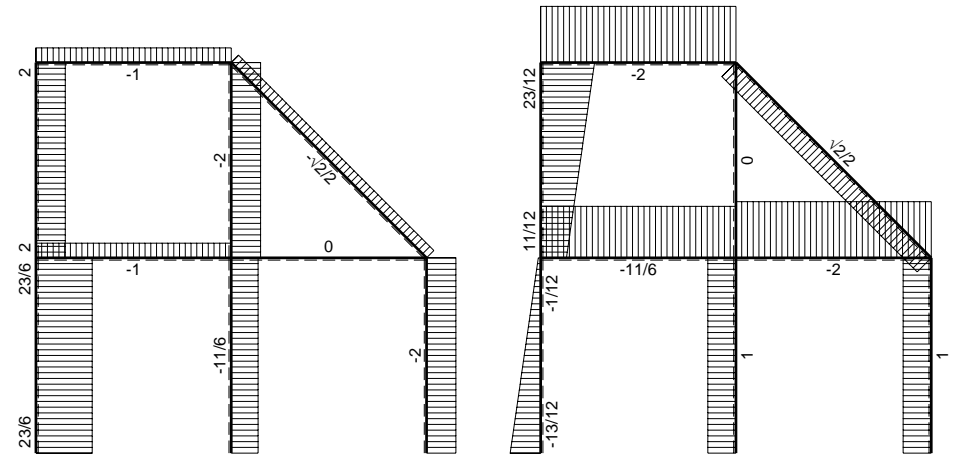
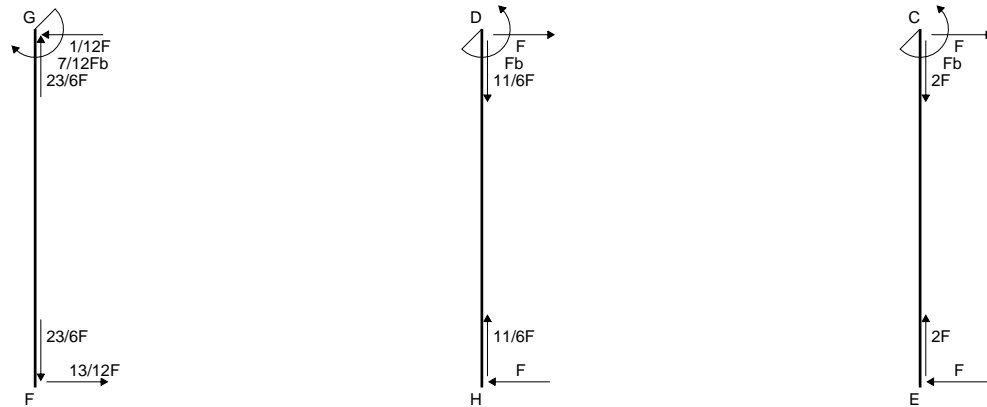
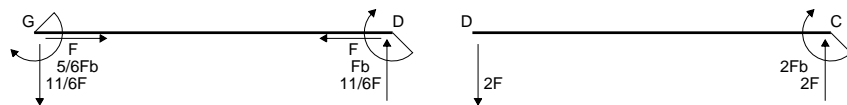
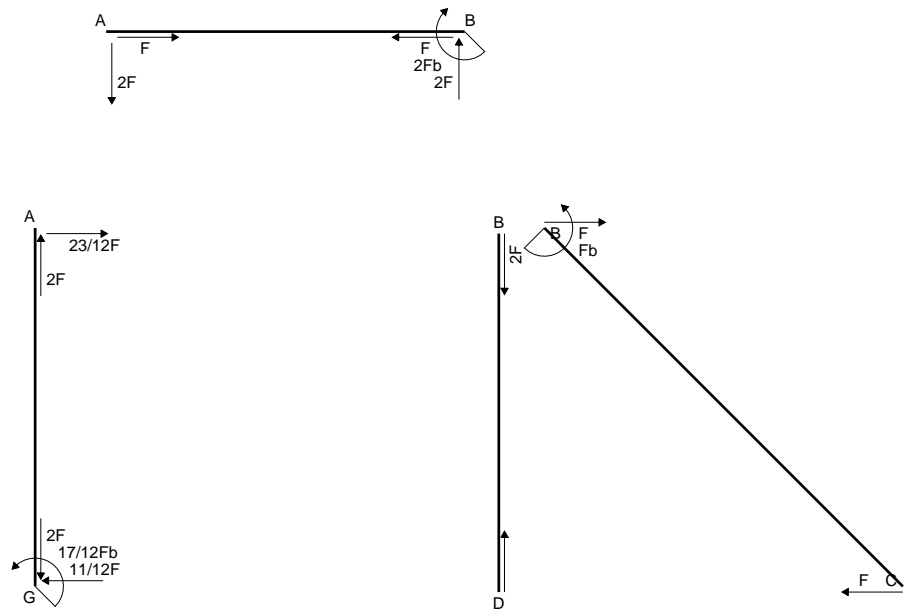

← ⊕ → F

↑ ⊕ ↓ F

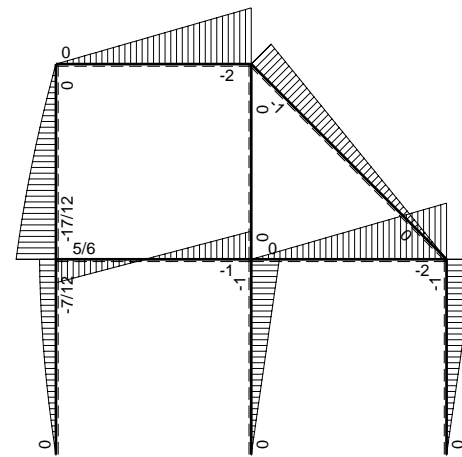

⊕ ⊖ Fb

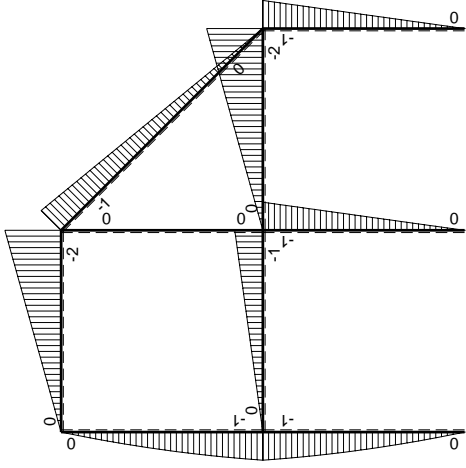
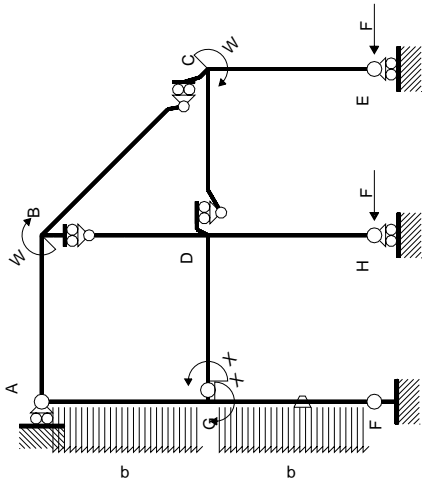

Schema di calcolo iperstatico

M_0 flessione da carichi assegnati

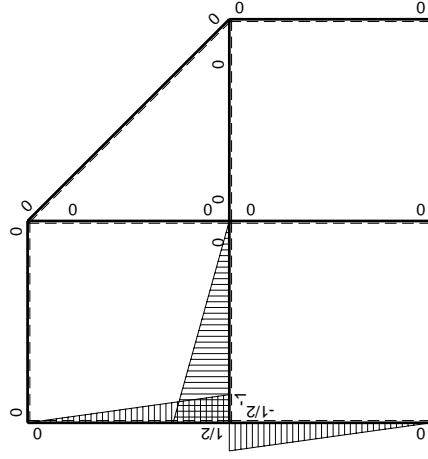

M_x flessione da iperstatica $X=1$

Quadro contributi PLV per iperstatica $X=W_{GD}$

→	$M_x(x)$	$M_o(x)$	θ	$M_x M_o$	$M_x \theta$	$M_x M_x$	$\int M_x(M_o/EJ+\theta)dx$	$\int X M_x M_x/EJ dx$
AB b	0	-2Fx	0	0	0	0	0+0	0
BA b	0	2Fb-2Fx	0	0	0	0		
BC $\sqrt{2}b$	0	-Fb+ $\sqrt{2}/2Fx$	0	0	0	0	0	0
BD b	0	0	0	0	0	0	0+0	0
DB b	0	0	0	0	0	0		
DC b	0	-2Fx	0	0	0	0	0+0	0
CD b	0	2Fb-2Fx	0	0	0	0		
CE b	0	-Fb+Fx	0	0	0	0	0+0	0
EC b	0	Fx	0	0	0	0		
FG b	-1/2x/b	-3/2Fx+1/2qx ²	-Fb/EJ	3/4Fx ² /b-1/4qx ³ /b	1/2Fx/EJ	1/4x ² /b ²	(3/16+1/4)Fb ² /EJ	1/12Xb/EJ
GF b	1/2-1/2x/b	Fb-1/2Fx-1/2qx ²	Fb/EJ	1/2Fb-3/4Fx+1/4qx ³ /b	1/2Fb/EJ-1/2Fx/EJ	1/4-1/2x/b+1/4x ² /b ²		
GD b	-1+x/b	-Fx	0	Fx-Fx ² /b	0	1-2x/b+x ² /b ²	(1/6+0)Fb ² /EJ	1/3Xb/EJ
DG b	x/b	Fb-Fx	0	Fx-Fx ² /b	0	x ² /b ²		
DH b	0	-Fb+Fx	0	0	0	0	0+0	0
HD b	0	Fx	0	0	0	0		
GA b	1/2-1/2x/b	-Fb+1/2Fx+1/2qx ²	0	-1/2Fb+3/4Fx-1/4qx ³ /b	0	1/4-1/2x/b+1/4x ² /b ²	(-3/16+0)Fb ² /EJ	1/12Xb/EJ
AG b	-1/2x/b	3/2Fx-1/2qx ²	0	-3/4Fx ² /b+1/4qx ³ /b	0	1/4x ² /b ²		
	totali						5/12Fb ² /EJ	1/2Xb/EJ
	iperstatica $X=W_{GD}$						-5/6Fb	

Sviluppi di calcolo iperstatica

$$L_{FG}^{xx} = \int_0^b (1/4 x^2/b^2) 1/EJ dx = [1/12 x^3/b^2]_0^b 1/EJ$$

$$= (1/12 b) 1/EJ = 1/12 b/EJ$$

$$L_{GF}^{xx} = \int_0^b (1/4 - 1/2 x/b + 1/4 x^2/b^2) 1/EJ dx = [1/4 x - 1/4 x^2/b + 1/12 x^3/b^2]_0^b 1/EJ$$

$$= (1/4 b - 1/4 b + 1/12 b) 1/EJ = 1/12 b/EJ$$

$$L_{GD}^{xx} = \int_0^b (1 - 2 x/b + x^2/b^2) 1/EJ dx = [x - x^2/b + 1/3 x^3/b^2]_0^b 1/EJ$$

$$= (b - b + 1/3 b) 1/EJ = 1/3 b/EJ$$

$$L_{DG}^{xx} = \int_0^b (x^2/b^2) 1/EJ dx = [1/3 x^3/b^2]_0^b 1/EJ$$

$$= (1/3 b) 1/EJ = 1/3 b/EJ$$

$$L_{GA}^{xx} = \int_0^b (1/4 - 1/2 x/b + 1/4 x^2/b^2) 1/EJ dx = [1/4 x - 1/4 x^2/b + 1/12 x^3/b^2]_0^b 1/EJ$$

$$= (1/4 b - 1/4 b + 1/12 b) 1/EJ = 1/12 b/EJ$$

$$L_{AG}^{xx} = \int_0^b (1/4 x^2/b^2) 1/EJ dx = [1/12 x^3/b^2]_0^b 1/EJ$$

$$= (1/12 b) 1/EJ = 1/12 b/EJ$$

$$L_{FG}^{xo} = \int_0^b (3/4 x^2/b^2 - 1/4 x^3/b^3) Fb 1/EJ dx + \int_0^b (1/2 x/b) \theta dx$$

$$= [1/4 x^3/b^2 - 1/16 x^4/b^3]_0^b Fb 1/EJ + [1/4 x^2/b]_0^b \theta$$

$$= (1/4 b - 1/16 b) Fb 1/EJ + (1/4 b) \theta = 7/16 Fb^2/EJ$$

$$L_{GF}^{xo} = \int_0^b (1/2 - 3/4 x/b + 1/4 x^2/b^2) Fb 1/EJ dx + \int_0^b (-1/2 + 1/2 x/b) \theta dx$$

$$= [1/2 x - 3/8 x^2/b + 1/16 x^3/b^2]_0^b Fb 1/EJ + [-1/2 x + 1/4 x^2/b]_0^b \theta$$

$$= (1/2 b - 3/8 b + 1/16 b) Fb 1/EJ + (-1/2 b + 1/4 b) \theta = 7/16 Fb^2/EJ$$

$$L_{GD}^{xo} = \int_0^b (x/b - x^2/b^2) Fb 1/EJ dx = [1/2 x^2/b - 1/3 x^3/b^2]_0^b Fb 1/EJ$$

$$= (1/2 b - 1/3 b) Fb 1/EJ = 1/6 Fb^2/EJ$$

$$L_{DG}^{xo} = \int_0^b (x/b - x^2/b^2) Fb 1/EJ dx = [1/2 x^2/b - 1/3 x^3/b^2]_0^b Fb 1/EJ$$

$$= (1/2 b - 1/3 b) Fb 1/EJ = 1/6 Fb^2/EJ$$

$$L_{GA}^{xo} = \int_0^b (-1/2 + 3/4 x/b - 1/4 x^2/b^2) Fb 1/EJ dx = [-1/2 x + 3/8 x^2/b - 1/16 x^3/b^2]_0^b Fb 1/EJ$$

$$= (-1/2 b + 3/8 b - 1/16 b) Fb 1/EJ = -3/16 Fb^2/EJ$$

$$L_{AG}^{xo} = \int_0^b (-3/4 x^2/b^2 + 1/4 x^3/b^3) Fb 1/EJ dx = [-1/4 x^3/b^2 + 1/16 x^4/b^3]_0^b Fb 1/EJ$$

$$= (-1/4 b + 1/16 b) Fb 1/EJ = -3/16 Fb^2/EJ$$

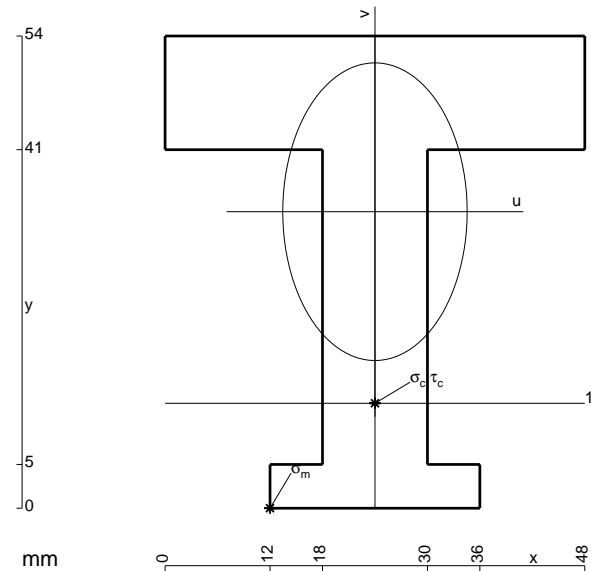

- A = 1176. mm²
- J_u = 340750. mm⁴
- J_v = 130752. mm⁴
- y_g = 33.91 mm
- N = -1290. N
- T_y = -2580. N
- M_x = -2089800. Nmm
- x_m = 12. mm
- u_m = -12. mm
- v_m = -33.91 mm
- σ_m = N/A-Mv/J_u = -209.1 N/mm²
- x_c = 24. mm
- y_c = 12. mm
- v_c = -21.91 mm
- σ_c = N/A-Mv/J_u = -135.5 N/mm²
- τ_c = 3.725 N/mm²
- σ_o = √σ²+3τ² = 135.6 N/mm²
- S = 5903. mm³

Quadro contributi PLV per iperstatica $X=W_{GD}$

→	$M_x(x)$	$M_o(x)$	θ	$M_x M_o$	$M_x \theta$	$M_x M_x$	$\int M_x(M_o/EJ+\theta)dx$	$\int x M_x M_x/EJ dx$
AB b	0	-2Fx	0	0	0	0	0+0	0
BA b	0	2Fb-2Fx	0	0	0	0		
BC $\sqrt{2}b$	0	-Fb+ $\sqrt{2}/2Fx$	0	0	0	0	0	0
BD b	0	0	0	0	0	0	0+0	0
DB b	0	0	0	0	0	0		
DC b	0	-2Fx	0	0	0	0	0+0	0
CD b	0	2Fb-2Fx	0	0	0	0		
CE b	0	-Fb+Fx	0	0	0	0	0+0	0
EC b	0	Fx	0	0	0	0		
FG b	-1/2x/b	-5/4Fx+1/2qx ²	-Fb/EJ	5/8Fx ² /b-1/4qx ³ /b	1/2Fx/EJ	1/4x ² /b ²	(7/48+1/4)Fb ² /EJ	1/12Xb/EJ
GF b	1/2-1/2x/b	3/4Fb-1/4Fx-1/2qx ²	Fb/EJ	3/8Fb-1/2Fx-1/8Fx ² /b+1/4qx ³ /b	1/2Fb/EJ-1/2Fx/EJ	1/4-1/2x/b+1/4x ² /b ²		
GD b	-1+x/b	-1/2Fx-1/2qx ²	0	1/2Fx-1/2qx ³ /b	0	1-2x/b+x ² /b ²	(1/8+0)Fb ² /EJ	1/3Xb/EJ
DG b	x/b	Fb-3/2Fx+1/2qx ²	0	Fx-3/2Fx ² /b+1/2qx ³ /b	0	x ² /b ²		
DH b	0	-Fb+Fx	0	0	0	0	0+0	0
HD b	0	Fx	0	0	0	0		
GA b	1/2-1/2x/b	-3/4Fb+3/4Fx	0	-3/8Fb+3/4Fx-3/8Fx ² /b	0	1/4-1/2x/b+1/4x ² /b ²	(-1/8+0)Fb ² /EJ	1/12Xb/EJ
AG b	-1/2x/b	3/4Fx	0	-3/8Fx ² /b	0	1/4x ² /b ²		
	totali						19/48Fb ² /EJ	1/2Xb/EJ
	iperstatica $X=W_{GD}$						-19/24Fb	

Sviluppi di calcolo iperstatica

$$L_{FG}^{xx} = \int_0^b (1/4 x^2/b^2) 1/EJ dx = [1/12 x^3/b^2]_0^b 1/EJ$$

$$= (1/12 b) 1/EJ = 1/12 b/EJ$$

$$L_{GF}^{xx} = \int_0^b (1/4 - 1/2 x/b + 1/4 x^2/b^2) 1/EJ dx = [1/4 x - 1/4 x^2/b + 1/12 x^3/b^2]_0^b 1/EJ$$

$$= (1/4 b - 1/4 b + 1/12 b) 1/EJ = 1/12 b/EJ$$

$$L_{GD}^{xx} = \int_0^b (1 - 2 x/b + x^2/b^2) 1/EJ dx = [x - x^2/b + 1/3 x^3/b^2]_0^b 1/EJ$$

$$= (b - b + 1/3 b) 1/EJ = 1/3 b/EJ$$

$$L_{DG}^{xx} = \int_0^b (x^2/b^2) 1/EJ dx = [1/3 x^3/b^2]_0^b 1/EJ$$

$$= (1/3 b) 1/EJ = 1/3 b/EJ$$

$$L_{GA}^{xx} = \int_0^b (1/4 - 1/2 x/b + 1/4 x^2/b^2) 1/EJ dx = [1/4 x - 1/4 x^2/b + 1/12 x^3/b^2]_0^b 1/EJ$$

$$= (1/4 b - 1/4 b + 1/12 b) 1/EJ = 1/12 b/EJ$$

$$L_{AG}^{xx} = \int_0^b (1/4 x^2/b^2) 1/EJ dx = [1/12 x^3/b^2]_0^b 1/EJ$$

$$= (1/12 b) 1/EJ = 1/12 b/EJ$$

$$L_{FG}^{xo} = \int_0^b (5/8 x^2/b^2 - 1/4 x^3/b^3) Fb 1/EJ dx + \int_0^b (1/2 x/b) \theta dx$$

$$= [5/24 x^3/b^2 - 1/16 x^4/b^3]_0^b Fb 1/EJ + [1/4 x^2/b]_0^b \theta$$

$$= (5/24 b - 1/16 b) Fb 1/EJ + (1/4 b) \theta = 19/48 Fb^2/EJ$$

$$L_{GF}^{xo} = \int_0^b (3/8 - 1/2 x/b - 1/8 x^2/b^2 + 1/4 x^3/b^3) Fb 1/EJ dx + \int_0^b (-1/2 + 1/2 x/b) \theta dx$$

$$= [3/8 x - 1/4 x^2/b - 1/24 x^3/b^2 + 1/16 x^4/b^3]_0^b Fb 1/EJ + [-1/2 x + 1/4 x^2/b]_0^b \theta$$

$$= (3/8 b - 1/4 b - 1/24 b + 1/16 b) Fb 1/EJ + (-1/2 b + 1/4 b) \theta = 19/48 Fb^2/EJ$$

$$L_{GD}^{xo} = \int_0^b (1/2 x/b - 1/2 x^3/b^3) Fb 1/EJ dx = [1/4 x^2/b - 1/8 x^4/b^3]_0^b Fb 1/EJ$$

$$= (1/4 b - 1/8 b) Fb 1/EJ = 1/8 Fb^2/EJ$$

$$L_{DG}^{xo} = \int_0^b (x/b - 3/2 x^2/b^2 + 1/2 x^3/b^3) Fb 1/EJ dx = [1/2 x^2/b - 1/2 x^3/b^2 + 1/8 x^4/b^3]_0^b Fb 1/EJ$$

$$= (1/2 b - 1/2 b + 1/8 b) Fb 1/EJ = 1/8 Fb^2/EJ$$

$$L_{GA}^{xo} = \int_0^b (-3/8 + 3/4 x/b - 3/8 x^2/b^2) Fb 1/EJ dx = [-3/8 x + 3/8 x^2/b - 1/8 x^3/b^2]_0^b Fb 1/EJ$$

$$= (-3/8 b + 3/8 b - 1/8 b) Fb 1/EJ = -1/8 Fb^2/EJ$$

$$L_{AG}^{xo} = \int_0^b (-3/8 x^2/b^2) Fb 1/EJ dx = [-1/8 x^3/b^2]_0^b Fb 1/EJ$$

$$= (-1/8 b) Fb 1/EJ = -1/8 Fb^2/EJ$$

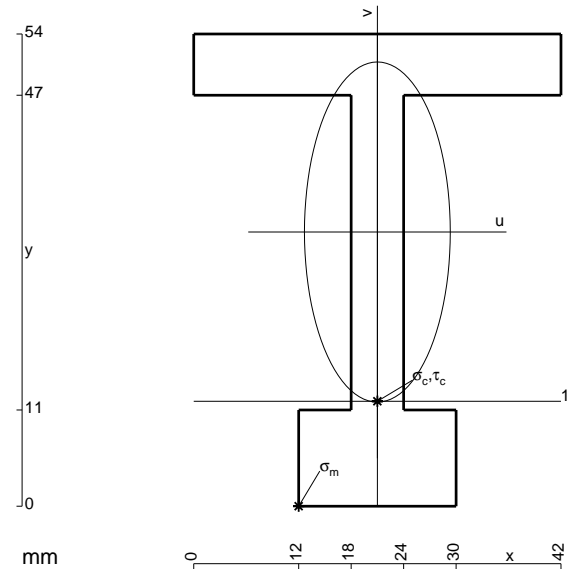

- A = 708. mm²
- J_u = 267842. mm⁴
- J_v = 49212. mm⁴
- y_g = 31.36 mm
- N = -1080. N
- T_y = -2160. N
- M_x = -1857600. Nmm
- x_m = 12. mm
- u_m = -9. mm
- v_m = -31.36 mm
- σ_m = N/A-Mv/J_u = -219. N/mm²
- x_c = 21. mm
- y_c = 12. mm
- v_c = -19.36 mm
- σ_c = N/A-Mv/J_v = -135.8 N/mm²
- τ_c = 7.041 N/mm²
- σ_o = √σ²+3τ² = 136.3 N/mm²
- S = 5239. mm³

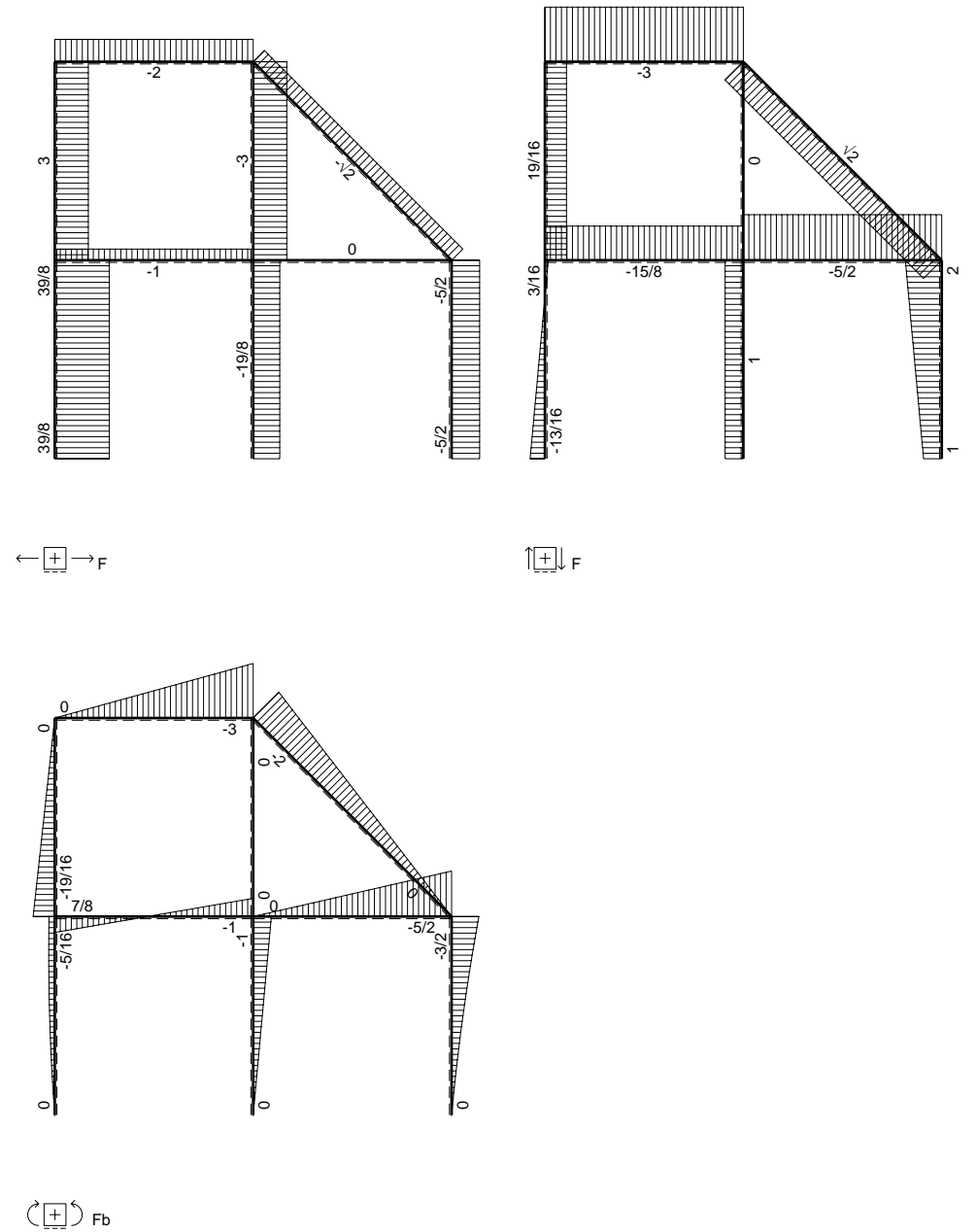
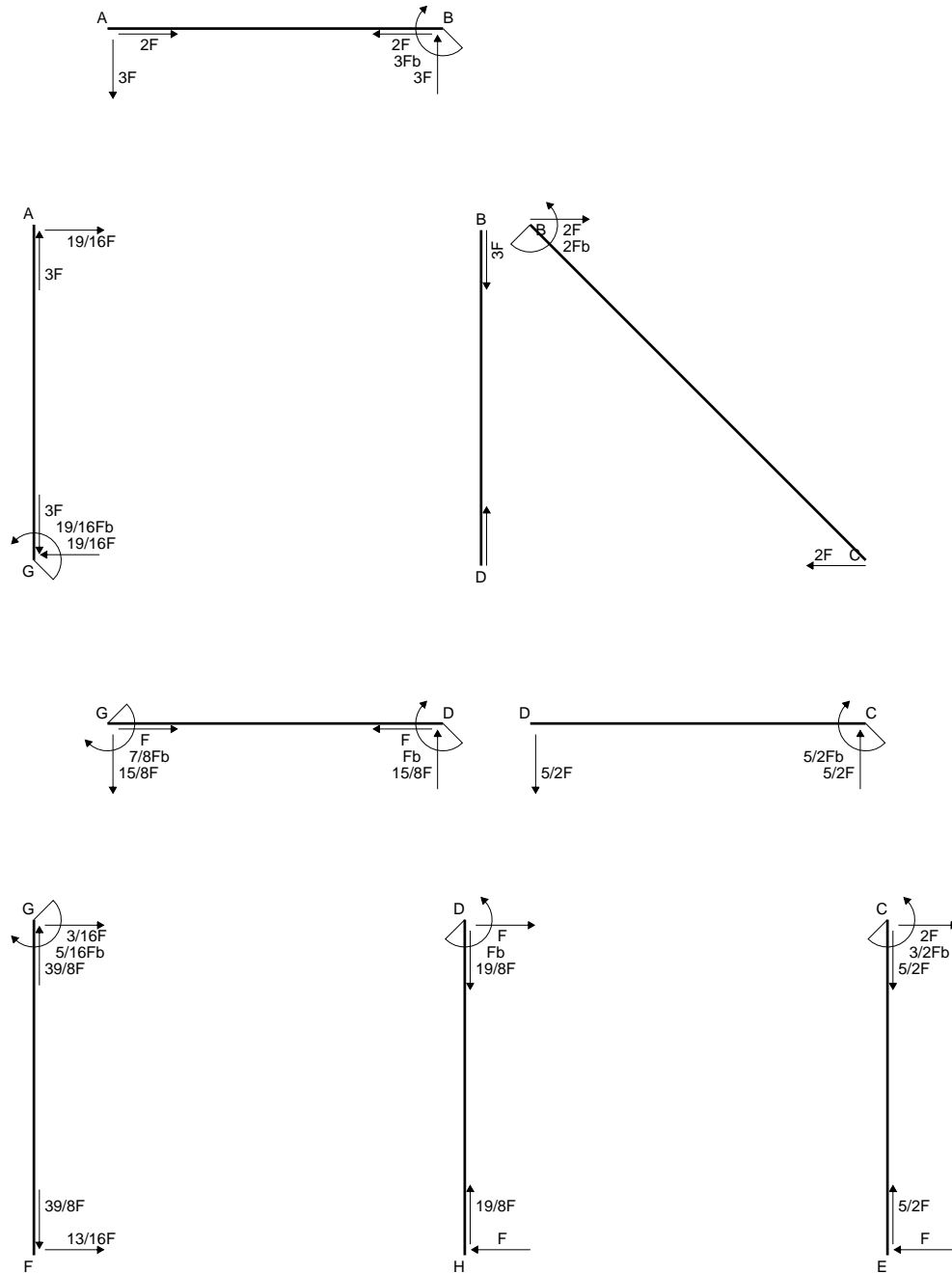

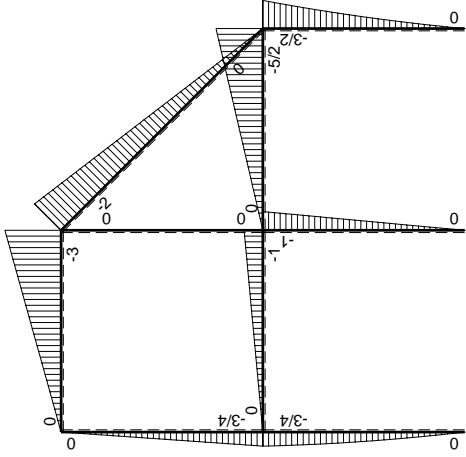
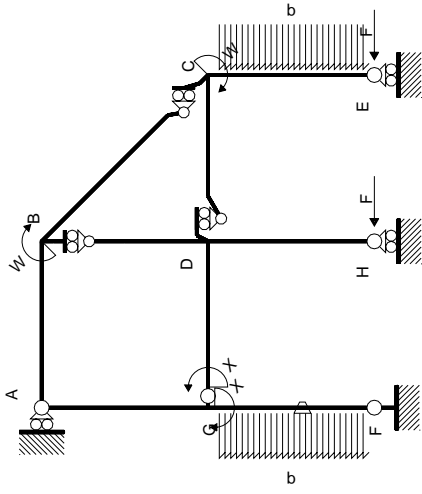

Schema di calcolo iperstatico

M_0 flessione da carichi assegnati

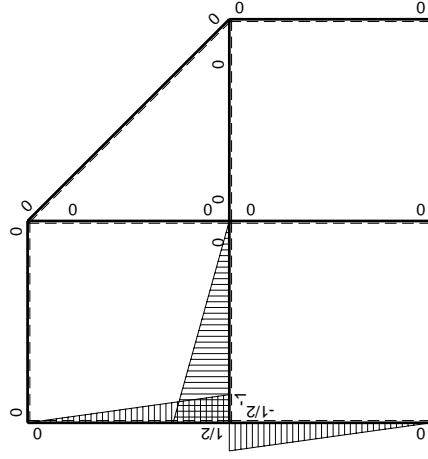

M_x flessione da iperstatica $X=1$

Quadro contributi PLV per iperstatica $X=W_{GD}$

→	$M_x(x)$	$M_o(x)$	θ	$M_x M_o$	$M_x \theta$	$M_x M_x$	$\int M_x(M_o/EJ+\theta)dx$	$\int x M_x M_x/EJ dx$
AB b	0	-3Fx	0	0	0	0	0+0	0
BA b	0	3Fb-3Fx	0	0	0	0		
BC $\sqrt{2}b$	0	-2Fb+ $\sqrt{2}Fx$	0	0	0	0	0	0
BD b	0	0	0	0	0	0	0+0	0
DB b	0	0	0	0	0	0		
DC b	0	-5/2Fx	0	0	0	0	0+0	0
CD b	0	5/2Fb-5/2Fx	0	0	0	0		
CE b	0	-3/2Fb+2Fx-1/2qx ²	0	0	0	0	0+0	0
EC b	0	Fx+1/2qx ²	0	0	0	0		
FG b	-1/2x/b	-5/4Fx+1/2qx ²	-Fb/EJ	5/8Fx ² /b-1/4qx ³ /b	1/2Fx/EJ	1/4x ² /b ²	(7/48+1/4)Fb ² /EJ	1/12Xb/EJ
GF b	1/2-1/2x/b	3/4Fb-1/4Fx-1/2qx ²	Fb/EJ	3/8Fb-1/2Fx-1/8Fx ² /b+1/4qx ³ /b	1/2Fb/EJ-1/2Fx/EJ	1/4-1/2x/b+1/4x ² /b ²		
GD b	-1+x/b	-Fx	0	Fx-Fx ² /b	0	1-2x/b+x ² /b ²	(1/6+0)Fb ² /EJ	1/3Xb/EJ
DG b	x/b	Fb-Fx	0	Fx-Fx ² /b	0	x ² /b ²		
DH b	0	-Fb+Fx	0	0	0	0	0+0	0
HD b	0	Fx	0	0	0	0		
GA b	1/2-1/2x/b	-3/4Fb+3/4Fx	0	-3/8Fb+3/4Fx-3/8Fx ² /b	0	1/4-1/2x/b+1/4x ² /b ²	(-1/8+0)Fb ² /EJ	1/12Xb/EJ
AG b	-1/2x/b	3/4Fx	0	-3/8Fx ² /b	0	1/4x ² /b ²		
	totali						7/16Fb ² /EJ	1/2Xb/EJ
	iperstatica $X=W_{GD}$						-7/8Fb	

Sviluppi di calcolo iperstatica

$$L_{FG}^{xx} = \int_0^b (1/4 x^2/b^2) 1/EJ dx = [1/12 x^3/b^2]_0^b 1/EJ$$

$$= (1/12 b) 1/EJ = 1/12 b/EJ$$

$$L_{GF}^{xx} = \int_0^b (1/4 - 1/2 x/b + 1/4 x^2/b^2) 1/EJ dx = [1/4 x - 1/4 x^2/b + 1/12 x^3/b^2]_0^b 1/EJ$$

$$= (1/4 b - 1/4 b + 1/12 b) 1/EJ = 1/12 b/EJ$$

$$L_{GD}^{xx} = \int_0^b (1 - 2 x/b + x^2/b^2) 1/EJ dx = [x - x^2/b + 1/3 x^3/b^2]_0^b 1/EJ$$

$$= (b - b + 1/3 b) 1/EJ = 1/3 b/EJ$$

$$L_{DG}^{xx} = \int_0^b (x^2/b^2) 1/EJ dx = [1/3 x^3/b^2]_0^b 1/EJ$$

$$= (1/3 b) 1/EJ = 1/3 b/EJ$$

$$L_{GA}^{xx} = \int_0^b (1/4 - 1/2 x/b + 1/4 x^2/b^2) 1/EJ dx = [1/4 x - 1/4 x^2/b + 1/12 x^3/b^2]_0^b 1/EJ$$

$$= (1/4 b - 1/4 b + 1/12 b) 1/EJ = 1/12 b/EJ$$

$$L_{AG}^{xx} = \int_0^b (1/4 x^2/b^2) 1/EJ dx = [1/12 x^3/b^2]_0^b 1/EJ$$

$$= (1/12 b) 1/EJ = 1/12 b/EJ$$

$$L_{FG}^{xo} = \int_0^b (5/8 x^2/b^2 - 1/4 x^3/b^3) Fb 1/EJ dx + \int_0^b (1/2 x/b) \theta dx$$

$$= [5/24 x^3/b^2 - 1/16 x^4/b^3]_0^b Fb 1/EJ + [1/4 x^2/b]_0^b \theta$$

$$= (5/24 b - 1/16 b) Fb 1/EJ + (1/4 b) \theta = 19/48 Fb^2/EJ$$

$$L_{GF}^{xo} = \int_0^b (3/8 - 1/2 x/b - 1/8 x^2/b^2 + 1/4 x^3/b^3) Fb 1/EJ dx + \int_0^b (-1/2 + 1/2 x/b) \theta dx$$

$$= [3/8 x - 1/4 x^2/b - 1/24 x^3/b^2 + 1/16 x^4/b^3]_0^b Fb 1/EJ + [-1/2 x + 1/4 x^2/b]_0^b \theta$$

$$= (3/8 b - 1/4 b - 1/24 b + 1/16 b) Fb 1/EJ + (-1/2 b + 1/4 b) \theta = 19/48 Fb^2/EJ$$

$$L_{GD}^{xo} = \int_0^b (x/b - x^2/b^2) Fb 1/EJ dx = [1/2 x^2/b - 1/3 x^3/b^2]_0^b Fb 1/EJ$$

$$= (1/2 b - 1/3 b) Fb 1/EJ = 1/6 Fb^2/EJ$$

$$L_{DG}^{xo} = \int_0^b (x/b - x^2/b^2) Fb 1/EJ dx = [1/2 x^2/b - 1/3 x^3/b^2]_0^b Fb 1/EJ$$

$$= (1/2 b - 1/3 b) Fb 1/EJ = 1/6 Fb^2/EJ$$

$$L_{GA}^{xo} = \int_0^b (-3/8 + 3/4 x/b - 3/8 x^2/b^2) Fb 1/EJ dx = [-3/8 x + 3/8 x^2/b - 1/8 x^3/b^2]_0^b Fb 1/EJ$$

$$= (-3/8 b + 3/8 b - 1/8 b) Fb 1/EJ = -1/8 Fb^2/EJ$$

$$L_{AG}^{xo} = \int_0^b (-3/8 x^2/b^2) Fb 1/EJ dx = [-1/8 x^3/b^2]_0^b Fb 1/EJ$$

$$= (-1/8 b) Fb 1/EJ = -1/8 Fb^2/EJ$$

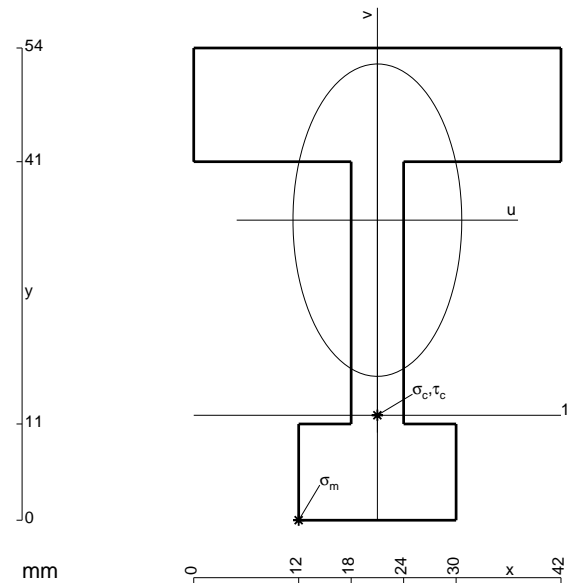

- A = 924. mm²
- J_u = 294950. mm⁴
- J_v = 86148. mm⁴
- y_g = 34.31 mm
- N = -1420. N
- T_y = -2130. N
- M_x = -1938300. Nmm
- x_m = 12. mm
- u_m = -9. mm
- v_m = -34.31 mm
- σ_m = N/A - Mv/J_u = -227. N/mm²
- x_c = 21. mm
- y_c = 12. mm
- v_c = -22.31 mm
- σ_c = N/A - Mv/J_v = -148.2 N/mm²
- τ_c = 7.031 N/mm²
- σ_o = √σ² + 3τ² = 148.7 N/mm²
- S = 5842. mm³

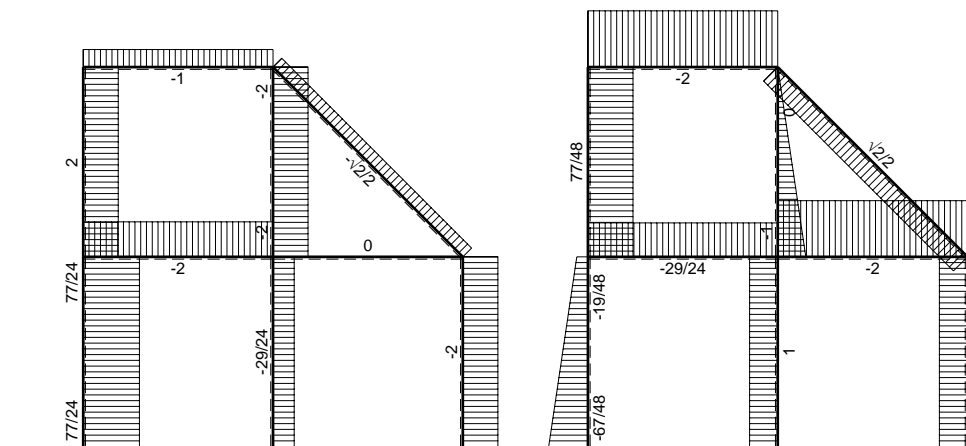
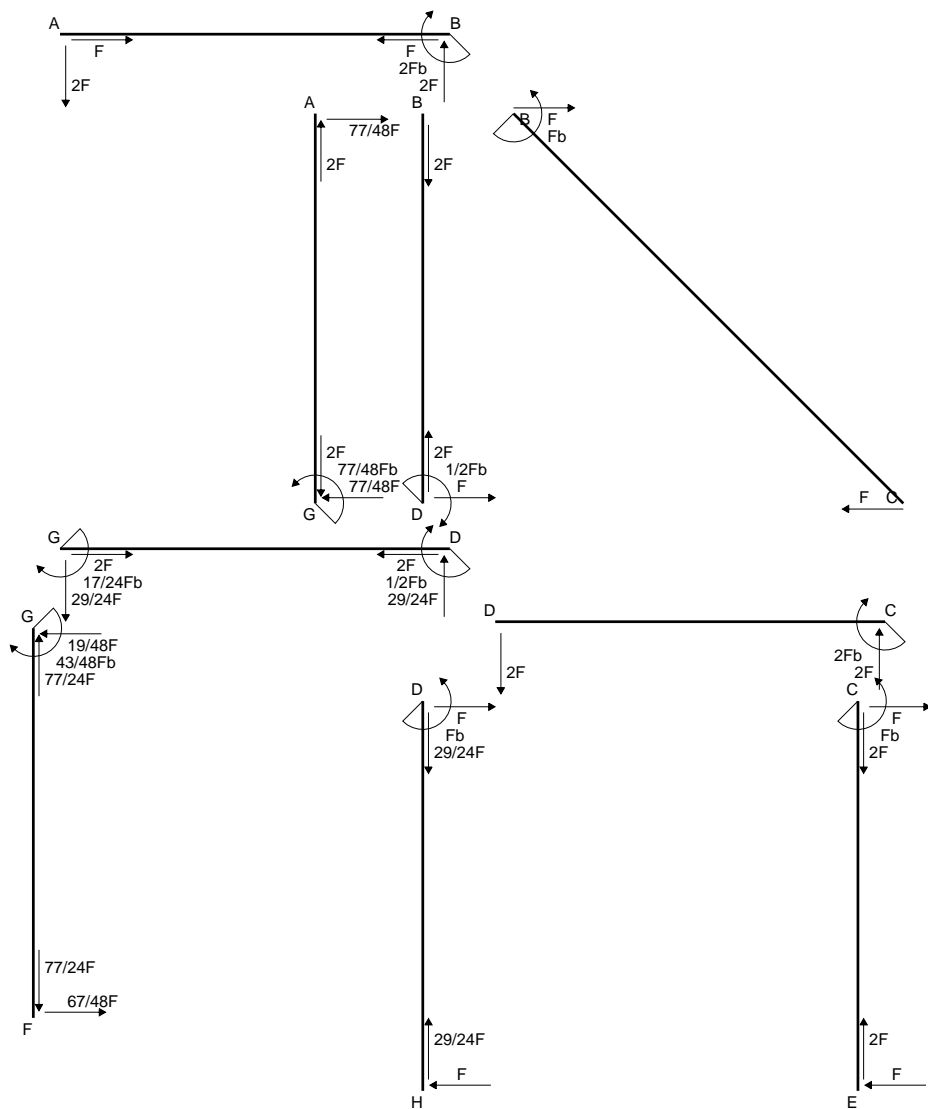

← ⊕ → F

↑ ⊕ ↓ F

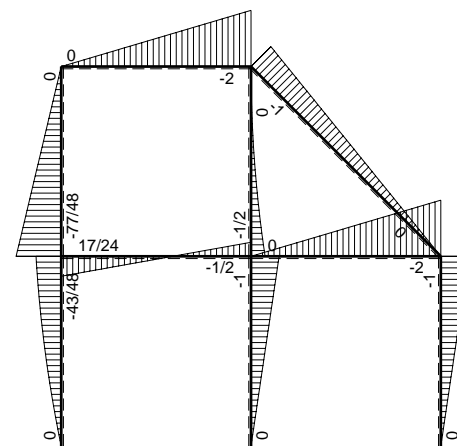

⊕ ⊖ F_b

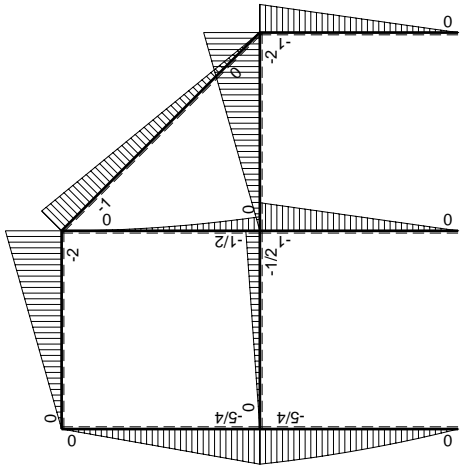
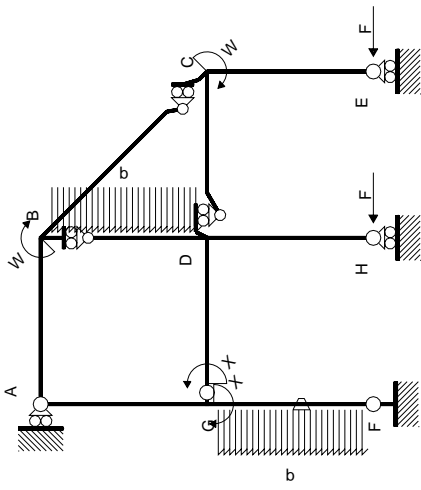

Schema di calcolo iperstatico

M_0 flessione da carichi assegnati

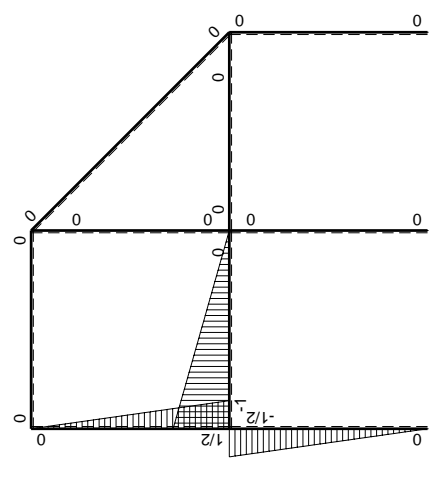

M_x flessione da iperstatica $X=1$

Quadro contributi PLV per iperstatica $X=W_{GD}$

→	$M_x(x)$	$M_o(x)$	θ	$M_x M_o$	$M_x \theta$	$M_x M_x$	$\int M_x(M_o/EJ+\theta)dx$	$\int X M_x M_x / EJ dx$
AB b	0	-2Fx	0	0	0	0	0+0	0
BA b	0	2Fb-2Fx	0	0	0	0	0	0
BC $\sqrt{2}b$	0	-Fb+ $\sqrt{2}/2Fx$	0	0	0	0	0	0
BD b	0	-1/2qx ²	0	0	0	0	0+0	0
DB b	0	1/2Fb-Fx+1/2qx ²	0	0	0	0	0	0
DC b	0	-2Fx	0	0	0	0	0+0	0
CD b	0	2Fb-2Fx	0	0	0	0	0	0
CE b	0	-Fb+Fx	0	0	0	0	0+0	0
EC b	0	Fx	0	0	0	0	0	0
FG b	-1/2x/b	-7/4Fx+1/2qx ²	-Fb/EJ	7/8Fx ² /b-1/4qx ³ /b	1/2Fx/EJ	1/4x ² /b ²	(11/48+1/4)Fb ² /EJ	1/12Xb/EJ
GF b	1/2-1/2x/b	5/4Fb-3/4Fx-1/2qx ²	Fb/EJ	5/8Fb-Fx+1/8Fx ² /b+1/4qx ³ /b	1/2Fb/EJ-1/2Fx/EJ	1/4-1/2x/b+1/4x ² /b ²		
GD b	-1+x/b	-1/2Fx	0	1/2Fx-1/2Fx ² /b	0	1-2x/b+x ² /b ²	(1/12+0)Fb ² /EJ	1/3Xb/EJ
DG b	x/b	1/2Fb-1/2Fx	0	1/2Fx-1/2Fx ² /b	0	x ² /b ²		
DH b	0	-Fb+Fx	0	0	0	0	0+0	0
HD b	0	Fx	0	0	0	0	0	0
GA b	1/2-1/2x/b	-5/4Fb+5/4Fx	0	-5/8Fb+5/4Fx-5/8Fx ² /b	0	1/4-1/2x/b+1/4x ² /b ²	(-5/24+0)Fb ² /EJ	1/12Xb/EJ
AG b	-1/2x/b	5/4Fx	0	-5/8Fx ² /b	0	1/4x ² /b ²		
	totali						17/48Fb ² /EJ	1/2Xb/EJ
	iperstatica $X=W_{GD}$						-17/24Fb	

Sviluppi di calcolo iperstatica

$$L_{FG}^{xx} = \int_0^b (1/4 x^2/b^2) 1/EJ dx = [1/12 x^3/b^2]_0^b 1/EJ$$

$$= (1/12 b) 1/EJ = 1/12 b/EJ$$

$$L_{GF}^{xx} = \int_0^b (1/4 - 1/2 x/b + 1/4 x^2/b^2) 1/EJ dx = [1/4 x - 1/4 x^2/b + 1/12 x^3/b^2]_0^b 1/EJ$$

$$= (1/4 b - 1/4 b + 1/12 b) 1/EJ = 1/12 b/EJ$$

$$L_{GD}^{xx} = \int_0^b (1 - 2 x/b + x^2/b^2) 1/EJ dx = [x - x^2/b + 1/3 x^3/b^2]_0^b 1/EJ$$

$$= (b - b + 1/3 b) 1/EJ = 1/3 b/EJ$$

$$L_{DG}^{xx} = \int_0^b (x^2/b^2) 1/EJ dx = [1/3 x^3/b^2]_0^b 1/EJ$$

$$= (1/3 b) 1/EJ = 1/3 b/EJ$$

$$L_{GA}^{xx} = \int_0^b (1/4 - 1/2 x/b + 1/4 x^2/b^2) 1/EJ dx = [1/4 x - 1/4 x^2/b + 1/12 x^3/b^2]_0^b 1/EJ$$

$$= (1/4 b - 1/4 b + 1/12 b) 1/EJ = 1/12 b/EJ$$

$$L_{AG}^{xx} = \int_0^b (1/4 x^2/b^2) 1/EJ dx = [1/12 x^3/b^2]_0^b 1/EJ$$

$$= (1/12 b) 1/EJ = 1/12 b/EJ$$

$$L_{FG}^{xo} = \int_0^b (7/8 x^2/b^2 - 1/4 x^3/b^3) Fb 1/EJ dx + \int_0^b (1/2 x/b) \theta dx$$

$$= [7/24 x^3/b^2 - 1/16 x^4/b^3]_0^b Fb 1/EJ + [1/4 x^2/b]_0^b \theta$$

$$= (7/24 b - 1/16 b) Fb 1/EJ + (1/4 b) \theta = 23/48 Fb^2/EJ$$

$$L_{GF}^{xo} = \int_0^b (5/8 - x/b + 1/8 x^2/b^2 + 1/4 x^3/b^3) Fb 1/EJ dx + \int_0^b (-1/2 + 1/2 x/b) \theta dx$$

$$= [5/8 x - 1/2 x^2/b + 1/24 x^3/b^2 + 1/16 x^4/b^3]_0^b Fb 1/EJ + [-1/2 x + 1/4 x^2/b]_0^b \theta$$

$$= (5/8 b - 1/2 b + 1/24 b + 1/16 b) Fb 1/EJ + (-1/2 b + 1/4 b) \theta = 23/48 Fb^2/EJ$$

$$L_{GD}^{xo} = \int_0^b (1/2 x/b - 1/2 x^2/b^2) Fb 1/EJ dx = [1/4 x^2/b - 1/6 x^3/b^2]_0^b Fb 1/EJ$$

$$= (1/4 b - 1/6 b) Fb 1/EJ = 1/12 Fb^2/EJ$$

$$L_{DG}^{xo} = \int_0^b (1/2 x/b - 1/2 x^2/b^2) Fb 1/EJ dx = [1/4 x^2/b - 1/6 x^3/b^2]_0^b Fb 1/EJ$$

$$= (1/4 b - 1/6 b) Fb 1/EJ = 1/12 Fb^2/EJ$$

$$L_{GA}^{xo} = \int_0^b (-5/8 + 5/4 x/b - 5/8 x^2/b^2) Fb 1/EJ dx = [-5/8 x + 5/8 x^2/b - 5/24 x^3/b^2]_0^b Fb 1/EJ$$

$$= (-5/8 b + 5/8 b - 5/24 b) Fb 1/EJ = -5/24 Fb^2/EJ$$

$$L_{AG}^{xo} = \int_0^b (-5/8 x^2/b^2) Fb 1/EJ dx = [-5/24 x^3/b^2]_0^b Fb 1/EJ$$

$$= (-5/24 b) Fb 1/EJ = -5/24 Fb^2/EJ$$

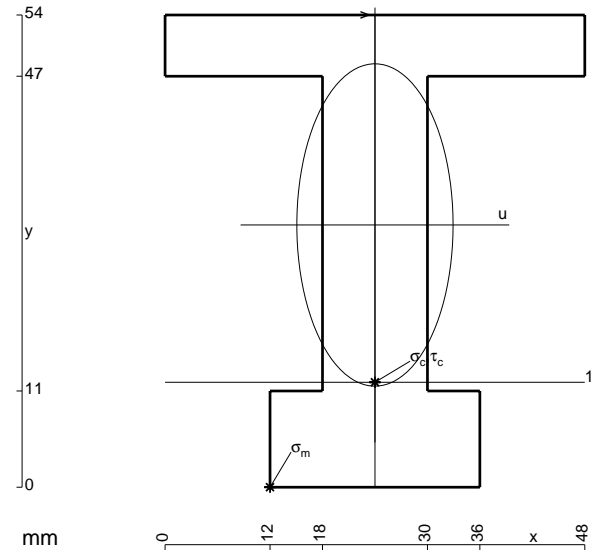

- A = 1032. mm²
- J_u = 350792. mm⁴
- J_v = 82368. mm⁴
- y_g = 29.99 mm
- N = -1450. N
- T_y = -2900. N
- M_x = -2784000. Nmm
- x_m = 12. mm
- u_m = -12. mm
- v_m = -29.99 mm
- σ_m = N/A-Mv/J_u = -239.4 N/mm²
- x_c = 24. mm
- y_c = 12. mm
- v_c = -17.99 mm
- σ_c = N/A-Mv/J_u = -144.2 N/mm²
- τ_c = 4.607 N/mm²
- σ_o = √σ²+3τ² = 144.4 N/mm²
- S = 6687. mm³